

AD-A042 827

OFFICE OF NAVAL RESEARCH LONDON (ENGLAND)
EUROPEAN SCIENTIFIC NOTES NUMBER 7-15, (U)
AUG 53 J R REITZ, S R ASPINALL
ESN-7-15

F/G 5/2

UNCLASSIFIED

NL

| OF |
ADA042827



END
DATE
FILMED
9-77
DDC

2020

ADA 042827

OFFICE OF NAVAL RESEARCH
LONDON

(1)

6

EUROPEAN SCIENTIFIC NOTES Number 7-15,

COPY AVAILABLE TO DDC DOES NOT
PERMIT FULLY LEGIBLE PRODUCTION

No. 7 - 15

12-17p.

11

1 August 1953

RECEIVED
OFFICE OF NAVAL RESEARCH
LONDON

14

ESN-7-15

Distributed by the Office of Naval Research
Washington 25, D. C.

DDC
RECEIVED
AUG 15 1977
RECEIVED

10
J. R. Reitz
S. R. Aspinall

DDC FILE COPY

This document is issued for information purposes only. Publication, reprinting, listing, or reproduction of it in any form, or of an abstract hereof, is not authorized except by specific prior approval of the Officer-in-Charge, Office of Naval Research, Branch Office, Navy 100, Fleet Post Office, New York, New York.

AMERICAN EMBASSY

LONDON, ENGLAND

265000

1B

OFFICE OF NAVAL RESEARCH
London

EUROPEAN SCIENTIFIC NOTES

ACCESSION FOR
NTIS
DDC
UNANNOUNCED
JUSTIFICATION
BY
DISTRIBUTION/AVAILABILITY CODES
Dist. AVAIL. CODE NO. SPECIAL
A 23

1 August 1953

No. 7 - 15

<u>PHYSICS</u>	<u>PAGE</u>
Scintillation Properties of CsI	168
Technique and Results	168
Conclusions	169
<u>CHEMISTRY</u>	
Bunsen Society Meeting	170
The Properties of Hydrogen Fluoride Vapor	170
Strontium Pernitride: A New Paramagnetic Compound	172
The Catalytic Decomposition of Nitrous Oxide	173
Thermodynamics of the Benzene-Diphenyl System	173
Azide Analogues of Metal Hydrides	174
Highly Chlorinated Unsaturated Compounds	175
<u>METALLURGY</u>	
Eutectic Systems	176
The Melting Point of Titanium	176
Phase Boundaries in Titanium Alloy Systems	177
<u>BIOSCIENCES</u>	
Experimental Cooling of the Bloodstream in Dogs	178
An Apparatus for Measuring the Thermal Conductivity of Animal Tissue	178
<u>MISCELLANEOUS</u>	
Technical Reports of ONRL	180
Personal News Item	181

AMERICAN EMBASSY

LONDON, ENGLAND

OFFICE OF NAVAL RESEARCH
London

EUROPEAN SCIENTIFIC NOTES

1 August 1953

7 - 15

SCINTILLATION PROPERTIES OF CsI

Dr. B. Hahn and Prof. J. Rossel of the University of Neuchâtel in Switzerland have recently conducted a study of the scintillation properties of CsI under α -particle bombardment. This investigation is a continuation of earlier work by Rossel and Dr. J. Bonanomi (Helvetica Physica Acta 25, 725 (1952)) in which a general study of the scintillation properties of the alkali iodides was made. The earlier work revealed that both CsI and KI prove high luminescent yields with short decay times at low temperatures. CsI was found to exhibit two luminescent components depending upon the temperature. The so-called hot component is present at room temperature but disappears below about 200°K. An additional luminescence called the cold component reveals itself only at temperatures below about 200°K and only provided that the CsI has not been maintained at an elevated temperature (\sim 670°K) during its preparation.

Hahn and Rossel have worked with single crystals of CsI grown from aqueous solution. The CsI crystals were prepared without the addition of any activator and the luminescence observed is therefore attributable either to imperfections of the crystal lattice or to unknown impurities. The latter explanation seems unlikely since deliberate addition of thalium (about 1%) produced no change in the luminescent yield at low temperature.

Technique and Results

Hahn and Rossel have measured the temperature dependence of the characteristic times associated with the luminescence of CsI from 77°K, the temperature of liquid nitrogen, to room temperature. They used a wide band

amplifier and fast oscilloscope, the combination having pulse rise times of less than 5×10^{-8} sec. At liquid nitrogen temperatures the luminescence was found to have an exponential decay with mean life of 0.5×10^{-6} sec. As the temperature was raised the decay continued to be that of a single exponential with somewhat decreased life time until about 135°K. Above this temperature the decay was found to be faster and more complex corresponding to at least two exponentials.

A study was also made of the relative luminescent yield as a function of temperature. This was accomplished by a pulse height analysis in which the pulse from the photomultiplier was applied to the horizontal plates of an oscilloscope while the vertical plates received the pulse after differentiation by an RC circuit. Each scintillation therefore produced a loop on the oscilloscope which crossed the horizontal axis at right angles at an abscissa equal to the height of the photomultiplier output pulse. The distribution of pulse heights was counted by a photocell which surveyed the horizontal axis of the oscilloscope through a narrow window which could be displaced by means of a micrometer screw. The relative luminescent yield was found to decrease monotonically as the temperature was raised from 77°K, falling to a negligible value at 300°K. The absolute luminescent yield, i.e. the fraction of α -particle energy transformed into luminescence by the crystal, was estimated by comparing pulse height distributions of scintillations in powdered CsI and powdered ZnS(Ag). The CsI was found to have a luminescent yield of 35% assuming that the ZnS(Ag) had a luminescent yield of 28% as measured by Kallmann.

The pulse height distribution resulting from the bombardment of CsI at liquid nitrogen temperature by α -particles from Po²¹⁰ was also analyzed by Hahn and Rossel. They found that the distribution consisted of a peak which had a width at half maximum of 5%. More than 80% of this width could be attributed to spread in the photomultiplier.

Conclusions

The work of Hahn and Rossel shows that at liquid nitrogen temperature CsI forms an excellent scintillator for the detection of heavy particles and measurement of their energy. The decay time is much shorter than in the case of ZnS and the energy resolution is, of course, incomparably better. An advantage of CsI over NaI is that

the former is not hygroscopic. Single crystals of CsI can be polished easily by hand with a moistened cloth and retain their surface and transparency in air for months. A disadvantage which is serious for some applications is that the high fluorescence yield and short decay time can be obtained only at low temperatures, requiring the use of liquid nitrogen or air. Hahn and Rossel have observed that the RCA 5819 photomultiplier loses nearly all its sensitivity below about 100°K. Consequently the tube must be kept warmer than the crystal and the problem of the optical connection of phosphor and a phototube requires attention.

Further investigation of the scintillation properties of CsI at liquid nitrogen temperature are in progress at Neuchâtel. The proportionality of pulse height to α -particle energy is being investigated. Preliminary results indicate that there is only a small deviation from proportionality.

BUNSEN SOCIETY MEETING

The annual meeting of the Bunsen Society in Duisburg on 14-17 May was again attended by a record number of German scientists, including about 25 physical chemists from East Berlin and the Eastern Zone of Germany. The papers and discussions testified to the continuing improvement of physico-chemical research in the universities of Western Germany. Since all the papers presented will be published in the Z. f. Elektrochem. within a few months' time, only a few new developments of particular significance are discussed below.

The Properties of Hydrogen Fluoride Vapor

The density of gaseous hydrogen fluoride over a wide range of temperatures and pressures has been investigated by Dr. W. Strohmeier and Prof. G. Briegleb (Würzburg). An elaborate vacuum system, made of silver, and including platinum valves, was used, and the precision claimed is 0.1%^o. The measurements covered the temperature range 26° - 56°C and were extended to pressures as low as a few mm. The sample was contained in a silver bulb of 2100 cc capacity and the effect of adsorption was investigated by filling this bulb with silver plates and thus increasing the total surface tenfold. The effect of adsorption was shown to be negligible.

The results were interpreted in terms of the chain association

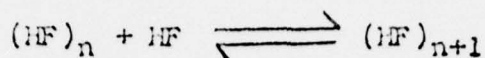

whose successive equilibrium constants were evaluated. The results suggest that association is significant up to about 40°C; at all temperatures studied, the associates are mainly chains, while the ring associate, $(\text{HF})_6$ makes a small contribution.

Dr. E. U. Franck (Göttingen) presented some recent results on the heat conductivity of hydrogen fluoride vapor which indicate that at somewhat lower temperatures, -5.5°C and $+3.5^\circ\text{C}$, six-membered rings are of critical importance in the composition of hydrogen fluoride vapor. The results are schematically shown in the figure below; it is noteworthy that the heat conductivity of hydrogen fluoride vapor under these conditions can be about as high as that of liquid water at the same temperature.

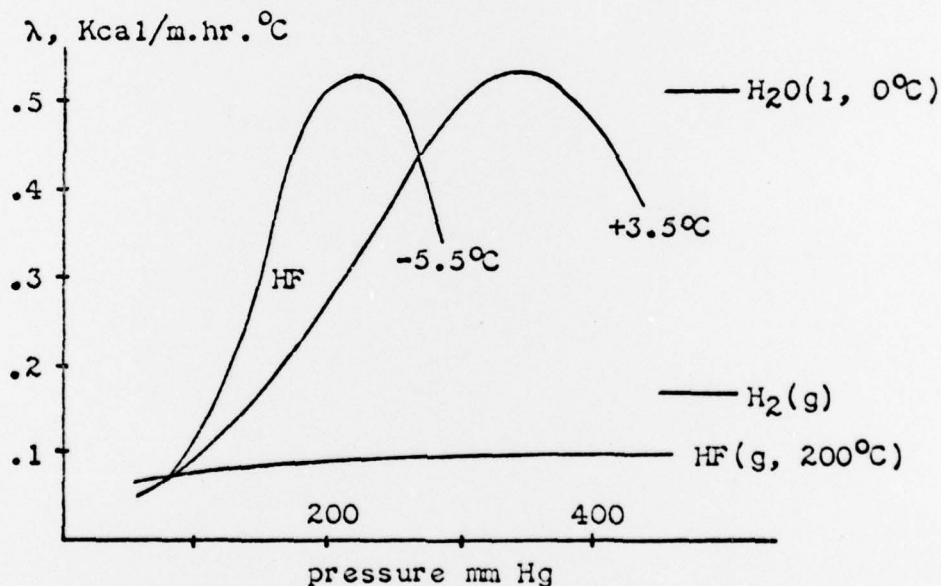

For comparison, the heat conductivity of liquid water, hydrogen gas, and hydrogen fluoride at 200°C are also included in this figure. The observed maxima prove that specific associates must exist; curves of the required shape were calculated by assuming that $(\text{HF})_6$ rings are responsible for the maxima. Thus the relative importance of chain vs. ring associate in HF vapor is primarily a function of the temperature.

Strontium Pernitride: A New Paramagnetic Compound

An investigation of the magnetic susceptibility of strontium pernitride, Sr_3N_4 , carried out by Dr. P. Ehrlich (Hannover) shows that the molecular ion N_2^{3-} is paramagnetic, as would be expected from the electronic configuration $[\text{:}\ddot{\text{N}}\text{:}\ddot{\text{N}}\text{:}]$; while the species is analogous to O_2^- in KO_2 and in CaCO_4 , the quantitative results reveal some interesting differences.

The pernitrides Cr_3N_4 and Sr_3N_4 were discovered during the war, but their physical properties have not yet been investigated in detail. The method of preparation given by Ehrlich can be summarized in the following equations:

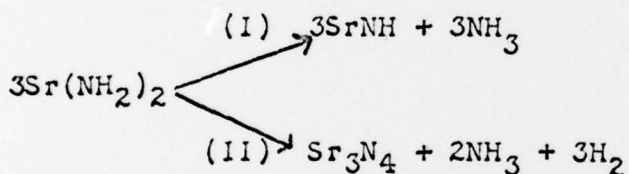
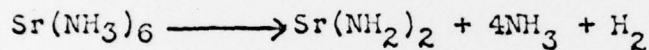

Reaction (I) takes place under normal conditions, while reaction (II) occurs under very high vacuum at room temperature. Strontium pernitride decomposes with hydrogen chloride according to

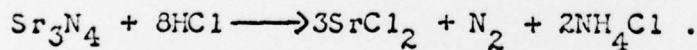

While the substance described by Hartmann in 1943 was red, Ehrlich was able to obtain this compound in various different colors, depending on the temperature and time of preparation.

The magnetic susceptibilities were measured between 900K and 6730K; while they exhibit a definite increase with temperature, they are always lower than those values which would be predicted theoretically. Ehrlich suggested that both the low value and the temperature dependence of the susceptibility might be interpreted by assuming that the paramagnetic ions are to some extent

coupled into diamagnetic dimers. In contrast to these results, the magnetic susceptibility of the O_2^- ion in KO_2 is in good agreement with the value predicted theoretically.

It should be noted that this is the first report of a paramagnetic molecule ion in which the unpaired electron is located on a nitrogen atom.

The Catalytic Decomposition of Nitrous Oxide

K. Hauffe (Düsseldorf) presented a clear analysis of the mechanism of nitrous oxide decomposition on nickel oxide showing that desorption is the rate controlling step in this decomposition.

The following mechanism was discussed:

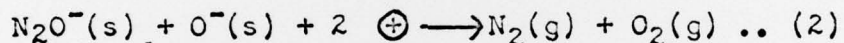
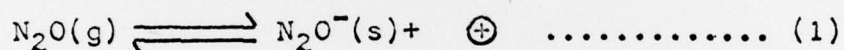

where (s) indicates a species on the surface, and \oplus is a positive hole.

Addition of small amounts of Li_2O increases the catalytic activity of the NiO , but 0.5% Li_2O is too much, and beyond this Li_2O concentration the catalyst deteriorates rapidly. This can readily be interpreted in terms of the reactions given, since the incorporation of Li_2O in the lattice leads to an increased concentration of positive holes, \oplus . While (2) is the rate-controlling step, the increased number of positive holes will increase the rate of decomposition; at about 0.4% Li_2O , however, (1) becomes rate controlling, and further addition reduces the catalytic activity.

THERMODYNAMICS OF THE BENZENE-DIPHENYL SYSTEM

A recent experimental determination by Professor G. Kortüm and Mr. Dreesen (Tübingen) of the heat of mixing of benzene and diphenyl at 71°C has given results which are in marked disagreement with those of earlier workers, and also in disagreement with theoretical predictions. They accentuate the well recognized need for accurate experimental work in this field over the widest possible temperature ranges.

Kortüm and Dreesen used a rather elaborate adiabatic calorimeter and determined the heats of mixing of benzene with diphenyl at 71°C; they also measured the vapor pressures for which the results are in good agreement with those of Everett and Penney (Proc. Roy. Soc., 212A, 164 (1952)) and of Baxendale et al (Phil. Trans. Roy. Soc., 243, 169 (1951)). The only previous direct calorimetric measurement on this system was that of Tompa at 25°C (J. Chem. Phys., 16, 292 (1948)), who concluded that the results can only be interpreted on the lattice model if the effect of different sizes of the components is taken into account.

Baxendale (loc. cit.) derived heat values by differentiating the activity coefficient results, and suggested that the partial molar heat contents and entropies are independent of temperature, in the range 20° - 80°C. Kortüm and Dreesen now find that the heat of mixing is considerably lower at 71°C than at 25°C. Combining their calorimetric heat of mixing with the appropriate free energy value, the non-ideal entropy of mixing at 71°C is zero within experimental error. Kortüm believes that this may be due to the fact that pure benzene is considerably less "ordered" at the higher temperatures than at 25°C, and thus the entropy due to the destruction of this order upon mixing is not important here. While this interpretation is open to question, the results obtained can hardly be reconciled with the theory of athermal solutions. This work will be published shortly in the Z. f. Naturforschung.

AZIDE ANALOGUES OF METAL HYDRIDES

Remarkable analogues of simple and mixed metal hydrides were recently discovered by Professor E. Wiberg (Munich). In reacting hydrazoic acid with lithium aluminum hydride in anhydrous ether, the following smooth reaction occurs:

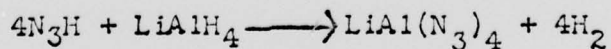

Systematic experiments indicate that a wide range of simple and mixed metal hydrides can undergo this reaction, and Professor Wiberg believes that all metallic hydrides can be converted into such azide analogues. Among the simple compounds, the boron compound, $\text{B}(\text{N}_3)_3$ is a liquid, while $\text{Al}(\text{N}_3)_3$ is a solid. It is of interest to note that the azide analogue of aluminum borohydride, $\text{Al}[\text{B}(\text{N}_3)_4]_3$

Perchlorofulvene is a stable, red, crystalline substance, which may be of some theoretical interest; the parent hydrocarbon, Fulvene, has never been prepared (cf. Ann. 569, 16 (1950)).

EUTECTIC SYSTEMS

Professor F. Mazzoleni, University of Naples, is studying the occurrence of eutectics in multi-component systems. He has made a complete survey of the literature and noted all the metallic systems which possess a eutectic. On the basis of known binary and ternary eutectics, he has predicted the occurrence of eutectics in various systems for which data are not available. Starting with binaries he has proceeded to ternaries, quaternaries, quinternaries, etc. If three elements all form binary eutectics, then it is certain that a ternary eutectic exists. The same reasoning applies to quaternary and higher systems.

The detection of a eutectic in a multi-element system is laborious and time consuming when the conventional exploratory technique is used. Mazzoleni has avoided this difficulty by adopting the fusion zone method developed for the purification of metals (cf. AIME 4, 747 (1952)). A sample composition selected from the system is subjected to zone melting so that the last portion of the alloy to solidify is the eutectic. By a combination of metallography, chemical and X-ray analysis, the presence of a eutectic and its composition are determined.

Aside from the interest in this problem from a fundamental standpoint, the study was initiated with the aim of developing new low-melting alloys without the use of bismuth, an element not readily available in Italy.

THE MELTING POINT OF TITANIUM

The published determinations of the melting point of titanium range from 1795° to 1680°C. This spread in results is in part attributable to the highly reactive nature of titanium and the experimental difficulties involved in preventing reaction with gases and refractories during melting. T. H. Schofield and A. E. Bacon of the National Physical Laboratory, Teddington, have redetermined the melting point of titanium by using the classical method of obtaining approximate black body conditions by measurement of the temperature at the bottom of a small deep hole in a uniformly heated specimen with an optical pyrometer. Particular

attention was paid to minimizing the surface area and the time of contact with the zirconia refractory crucible. The experiments were carried out in vacuum using high purity (iodide) titanium with a total time of heating to the melting point of only one-half hour.

The investigation gave a result of $1660 \pm 10^\circ\text{C}$ for the melting point. The technique used by the investigators was checked by making melting point determinations for nickel, iron, and platinum, and excellent agreement was obtained with the accepted values.

PHASE BOUNDARIES IN TITANIUM ALLOY SYSTEMS

There appears to be some discrepancy in the published values for the beta - alpha plus beta boundaries in titanium alloy phase diagrams. Results for alloys with vanadium, chromium, manganese, and nickel are in variance, particularly with the determinations made by Dr. A. D. McQuillan of Birmingham University by the hydrogen pressure method. McQuillan has recently investigated the reasons for these differences by some experiments with a 2.4 atomic per cent nickel-titanium alloy. The beta - alpha plus beta boundary for this composition has been reported by McQuillan to occur at 805°C while others have obtained a temperature of 875°C .

Specimens of the alloy were homogenized and then water quenched from 820°C after delay times of 0.4, 3, 6, and 10 seconds respectively. A metallographic examination of the specimens showed a progressive increase in the quantity of alpha formed by nucleation and growth during the brief delay times. In an additional experiment, a sample was heated to 820°C and suspended on a thermocouple in a manner such that it could be instantaneously quenched. This procedure produced a microstructure consisting entirely of transformed beta, again confirming McQuillan's original result for the beta - alpha plus beta boundary.

Thus, McQuillan has shown that the higher solubility lines for alpha plus beta reported by other investigators is due to insufficiently rapid quenching from the high temperature. The alpha phase can form by extremely rapid nucleation and growth, and the conventional method of quenching specimens enclosed in protective silica tubes (thus incurring a delay) can lead to considerable uncertainty in the determination of the phase boundaries in titanium alloy constitution diagrams.

EXPERIMENTAL COOLING OF THE BLOODSTREAM IN DOGS

Dr. E. J. Delorme working in the laboratory of Sir James Learmonth in the Department of Surgery of the University of Edinburgh has perfected a method for cooling the bloodstream of dogs. The present apparatus consists of a double-walled plastic tubing device which permits circulation of the animal's blood through the inner system and circulation of ice water through the outer system. By means of this apparatus arterial blood is cooled to a temperature of 10° to 20°C before it returns to the body circulation through the femoral vein. Over a period of 30 to 45 minutes the temperature of the animal is lowered to 22° - 29°C as measured by means of a thermometer inserted subcutaneously through a stab wound in the thigh on the side opposite to the operative field.

It has been found after experiments involving well over 100 dogs that when the animals are cooled by the method described to about 26°C, they can then be subjected to various procedures which have brought about death of normal animals. When so cooled the animal appears comfortable, very little anesthesia is required, and the heart rate is somewhat slowed but is regular. There is no shivering or other sign of distress and venous pressure remains normal until the blood circulation is interrupted in the process of obtaining a "dry" operative field. "Bloodless" surgery of the cephalic, thoracic, and abdominal organs can be carried out, and when the circulation is restored and the temperature returns to normal, uncomplicated recovery with minimal or no sign of neurological, morphological, or functional disturbance takes place.

For further details see Technical Report ONRL-83-53, available from the Technical Publications Office, Code 740, Office of Naval Research, Washington 25, D.C.

AN APPARATUS FOR MEASURING THE THERMAL CONDUCTIVITY OF ANIMAL TISSUE

H. S. Hatfield of the Medical Research Council's Laboratories, London, has applied the heat-flow meter previously described (J. Physiol., 111, 10 (1950)) to the measurement of the thermal conductivity of small pieces of excised tissue. A steady measured flow of heat (H) is sent through a small disk of tissue (thickness s), and the

difference of temperature (ΔT) between the two sides of the disk is measured. The thermal conductivity is $H_s/\Delta T$.

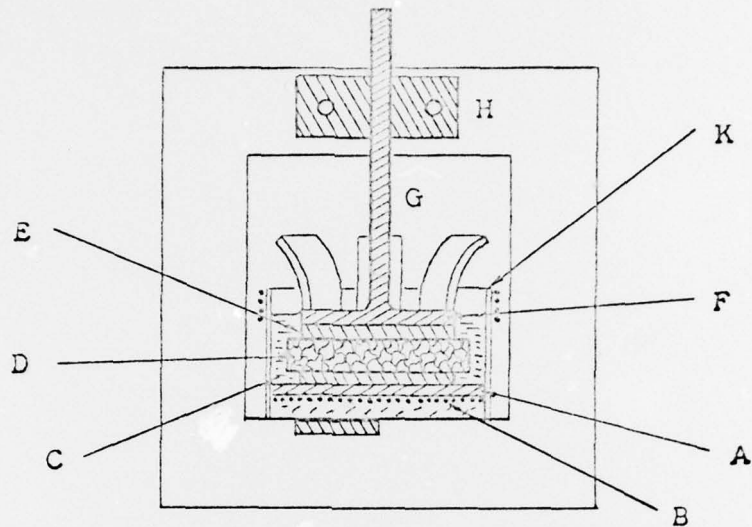

Sectional Elevation of Thermal Conductivity Unit

In the figure (sectional elevation), A is a circular disk of copper 1 mm thick, heated on its underside by resistance B. A heat-flow meter C is sealed with wax to its upper surface. The tissue D rests on the meter, and is capped by a second meter E sealed to a circular piece of thin copper F with cooling fins supported by a brass rod G passing through a screw-clamp on a thin aluminum frame H. When a steady current is passed through B, a steady flow of heat takes place through the tissue and the two meters, by which it is measured. Thermojunctions are soldered to the two coppers A and F, and give the difference in temperature between them.

The paper cup K carries an auxiliary resistance heater in ring form, opposing the flow radially of the heat flowing upwards. Its adjustment enables the two meters to be brought to approximately the same reading. The cup is filled with thick oil, which prevents evaporation of moisture. A zero observation with the two meters in contact (under oil) gives a heat-flow H_0 for temperature difference ΔT_0 . $\Delta T_0/H_0 = R$ is the thermal resistance of the apparatus. This R multiplied by the observed heat-flow when a specimen of tissue is in the apparatus gives that part of the observed temperature

difference which is due to the apparatus, and must be deducted from measured values.

Most tissue (such as human fat and muscle) cannot be cut into thin uniform slices at room temperature. A large piece was therefore laid on a block of solid CO₂, and when frozen hard, slices were cut from it by a hand-saw, scraped smooth, and punched into disks by a cork-borer. In this way the material suffers little mechanical deformation, and retains its shape when thawed soft in the apparatus. Comparison of beef muscle which could be sliced unfrozen, with the same frozen, indicated that freezing does not materially affect the conductivity. Table I summarizes the observations made with two apparatuses of the same type which were used in pairs to provide a check on the accuracy of the results.

TABLE I

(Thermal conductivity expressed as cal cm/cm² sec°C)

Material	No. of tests	Meter I	Standard Deviation	Meter II	Standard Deviation
Beef muscle:					
Frozen	57	0.00132	0.00047	0.00119	0.00036
Unfrozen	39	0.00130	0.00033	0.00124	0.00031
Beef Fat	6	0.00053	0.000012	0.00052	0.000039
Human Muscle,					
Frozen	62	0.00101	0.00022	0.00108	0.00020
Human Fat	34	0.000446	0.000059	0.000507	0.000059

TECHNICAL REPORTS OF ONRL

The following reports have been forwarded to CNR, Washington, since the last issue of ESN. Copies may be obtained from the Technical Publications Office, Code 740, Office of Naval Research, Washington 25, D.C.

ONRL-53-53 "Research in Physical and Theoretical Metallurgy at Birmingham" by E. Epremian

ONRL-56-53 "Conference on Lattice Defects and the Electrical Resistivity of Metals" by E. Epremian and J. R. Reitz

- ONRL-58-53 "Measurements of Cerenkov Radiation at Padua"
by W. L. Hyde
- ONRL-77-53 "Research at the Department of Colloid
Science, Cambridge University" by
J. L. Nickerson
- ONRL-78-53 "Electronic Computer Development in the
Netherlands" by R. R. Weber
- ONRL-79-53 "Some Swedish Research in Solid State Physics"
by J. R. Reitz
- ONRL-80-53 "Research on Perception, National Defence Re-
search Council TNO, The Netherlands" by
C. H. Graham
- ONRL-81-53 "Research on Highly Chlorinated Unsaturated
Compounds at the University of Würzburg" by
G. J. Szasz
- ONRL-83-53 "The Department of Surgery at the University
of Edinburgh" by J. L. Tullis
- ONRL-84-53 "The Ergonomics Research Society Symposium on
Human Performance, Its Measurement and Limi-
tations" by J. L. Nickerson
- ONRL-85-53 "An Improved Technique for the Demonstration
of Trichinella Spiralis in Muscle" by
J. L. Nickerson
- ONRL-86-53 "Professional Training in Optometry, Great
Britain" by C. H. Graham
- ONRL-89-53 "Plans for a Computing Machine at the Istituto
Nazionale per le Applicazioni del Calcolo" by
R. R. Weber

PERSONAL NEWS ITEM

CORONATION HONORS LIST, 1953

The following scientists were awarded Coronation
Honors:

Knight Bachelor: Dr. E. C. Bullard, Director, National
Physical Laboratory, D.S.I.R.

Knight Commander of the Bath: Sir John Cockcroft,
Director, Atomic Energy
Research Establishment.

Knight of the British Empire: Prof. Hugh Scott Taylor,
Professor of Chemistry
and Dean of Graduate
School, Princeton
University.

Commander of the British Empire: Mr. F. S. Barton,
Principal Director
of Electronics Re-
search and Develop-
ment, Ministry of
Supply.
Dr. J. E. Hurst,
President, British
Cast Iron Research
Association.
Mr. D. A. Oliver,
Metals Economy
Adviser, Ministry
of Supply.

Prepared by the Scientific Staff
Edited by J. R. Reitz
Submitted by Dr. S. R. Aspinall
Deputy Scientific Director



E. R. DARE
CDR, U.S.N.
Acting Officer-in-Charge