

AD-A043 022

AIR FORCE AERO PROPULSION LAB WRIGHT-PATTERSON AFB OHIO F/G 21/2
A REVIEW OF TURBOPROPULSION COMBUSTION, PART I. FUNDAMENTALS OF--ETC(U)
JUN 77 W S BLAZOWSKI, R E HENDERSON
AFAPL-TR-77-41

UNCLASSIFIED

MI

OF |
AD
A043 022

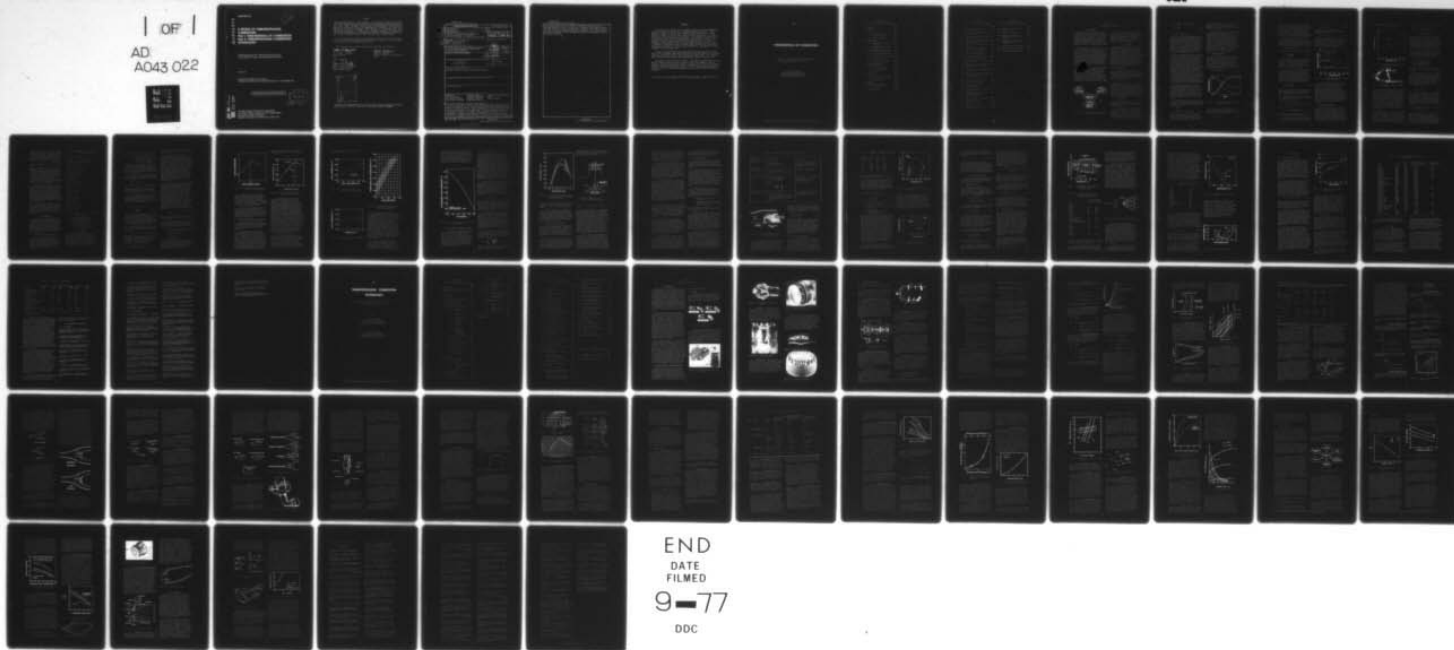

END
DATE
FILMED
9-77
DDC

AD A 043022

AFAPL-TR-77-41

12

J

**A REVIEW OF TURBOPROPULSION
COMBUSTION
Part I. FUNDAMENTALS OF COMBUSTION
Part II. TURBOPROPULSION COMBUSTION
TECHNOLOGY**

*COMPONENTS BRANCH, TURBINE ENGINE DIVISION
FUELS BRANCH, FUELS AND LUBRICATION DIVISION*

JUNE 1977

TECHNICAL REPORT AFAPL-TR-77-41
TECHNOLOGY SUMMARY FOR PERIOD MARCH 1975 - DECEMBER 1976

Approved for public release; distribution unlimited

DDC
RECEIVED
AUG 18 1977
A

DDC FILE COPY

AIR FORCE AERO PROPULSION LABORATORY
AIR FORCE WRIGHT AERONAUTICAL LABORATORIES
AIR FORCE SYSTEMS COMMAND
WRIGHT-PATTERSON AIR FORCE BASE, OHIO 45433

NOTICE

When Government drawings, specifications, or other data are used for any purpose other than in connection with a definitely related Government procurement operation, the United States Government thereby incurs no responsibility nor any obligation whatsoever; and the fact that the government may have formulated, furnished, or in any way supplied the said drawings, specifications, or other data, is not to be regarded by implication or otherwise as in any manner licensing the holder or any other person or corporation, or conveying any rights or permission to manufacture, use, or sell any patented invention that may in any way be related thereto.

This report has been reviewed by the Information Office, ASD/OIP, and is releasable to the National Technical Information Service (NTIS). At NTIS, it will be available to the general public, including foreign nations.

This technical report has been reviewed and is approved for publication.

William S. Blazowski

DR. WILLIAM S. BLAZOWSKI
Project Engineer
USAF

Robert E. Henderson

ROBERT E. HENDERSON
Manager, Combustion Technology Group
USAF

FOR THE COMMANDER

James L. Radloff

JAMES L. RADLOFF, Major, USAF
Chief, Components Branch
Turbine Engine Division

ACCESSION TO		
NTIS	Write Section	<input checked="" type="checkbox"/>
DDC	Buy Section	<input type="checkbox"/>
UNANNOUNCED		<input type="checkbox"/>
JUSTIFICATION		
BY		
DISTRIBUTION/AVAILABILITY CODES		
Dist.	AVAIL. AND W. SPECIAL	
A		

Copies of this report should not be returned unless return is required by security considerations, contractual obligations, or notice on a specific document.

UNCLASSIFIED

SECURITY CLASSIFICATION OF THIS PAGE (When Data Entered)

REPORT DOCUMENTATION PAGE		READ INSTRUCTIONS BEFORE COMPLETING FORM
1. REPORT NUMBER AFAPL-TR-77-41	2. GOVT ACCESSION NO.	3. RECIPIENT'S CATALOG NUMBER
4. TITLE (and Subtitle) A Review of Turborpropulsion Combustion, Part I. Fundamentals of Combustion. Part II. Turborpropulsion Combustion Technology.		5. TYPE OF REPORT & PERIOD COVERED Technology Summary rept. March 1975 - December 1976.
7. AUTHOR(s) Dr. William S. Blazowski Robert E. Henderson		6. PERFORMING ORG. REPORT NUMBER
9. PERFORMING ORGANIZATION NAME AND ADDRESS Air Force Aero Propulsion Laboratory (AFAPL/TBC) Air Force Wright Aeronautical Laboratories Air Force Systems Command Wright Patterson AFB OH 45433		8. CONTRACT OR GRANT NUMBER(s)
11. CONTROLLING OFFICE NAME AND ADDRESS		10. PROGRAM ELEMENT, PROJECT, TASK AREA & WORK UNIT NUMBERS 62203F/3066/05 62203B/3048/05
14. MONITORING AGENCY NAME & ADDRESS (if different from Controlling Office)		12. REPORT DATE June 1977
16. DISTRIBUTION STATEMENT (of this Report) Approved for Public Release; Distribution Unlimited		13. NUMBER OF PAGES 56
17. DISTRIBUTION STATEMENT (of the abstract entered in Block 20, if different from Report)		15. SECURITY CLASS. (of this report) Unclassified
18. SUPPLEMENTARY NOTES		15a. DECLASSIFICATION/DOWNGRADING SCHEDULE
19. KEY WORDS (Continue on reverse side if necessary and identify by block number) Combustion Combustor Design Combustor Aerothermodynamics Reaction Kinetics Combustor Performance Fuels Gas Turbine Pollution Combustor Modeling Emission Control Exhaust Mass Emissions Combustion Chemistry		
20. ABSTRACT (Continue on reverse side if necessary and identify by block number) This report constitutes a reprint of two chapters on turbopropulsion combustion expressly prepared as part of a Propulsion Text Book entitled "A Comprehensive Study of Aircraft Gas Turbine Engines, edited by G.C. Oates, Professor of the University of Washington, to be published in 1977 as an Air Force Aero Propulsion Laboratory report. This report contains Chapter 15 dealing with the fundamentals of combustion and Chapter 20 dealing with the current state of technology of turbopropulsion combustion. A variety of subjects are reviewed ranging from fundamental chemistry, thermodynamics and gas dynamics of combustion		

14
6

10

9

16

17 05
05

11

12 64pp

011570

LB

UNCLASSIFIED

SECURITY CLASSIFICATION OF THIS PAGE(When Data Entered)

to jet engine combustor design factors, performance characteristics and engineering/analysis tools. In addition, the impact of environmental controls and regulations is discussed and the effects alternate and/or non-spec fuels may have on combustion system performance is examined. Each chapter includes an extensive reference list of related topics many of which expand further on key points discussed.

UNCLASSIFIED

SECURITY CLASSIFICATION OF THIS PAGE(When Data Entered)

FOREWORD

This review is a reprint of two Chapters dealing with the fundamentals and current state of technology in turbopropulsion combustion. These Chapters, Chapter 15 and 20, were expressly prepared as part of a Comprehensive Study of Aircraft Gas Turbine Engines, edited by G. C. Oates, Professor of the University of Washington. This propulsion textbook will be published by the Air Force Aero-Propulsion Laboratory in 1977. The Combustion Chapters reprinted herein were authored by Dr. William S. Blazowski,* Fuels Branch, Fuels and Lubrication Division, and Mr. Robert E. Henderson, Components Branch, Turbine Engine Division, Air Force Aero-Propulsion Laboratory, Air Force Wright Aeronautical Laboratories, Wright-Patterson Air Force Base, Ohio.

The work reported herein was assembled and written during the period March 1975 to December 1976 under the direction of the authors, Dr. William Blazowski (AFAPL/SFF) and Mr. Robert Henderson (AFAPL/TBC). The Chapters were released by the authors for textbook publication in January 1977.

The authors wish to thank Mr. Frank J. Verkamp of Detroit Diesel Allison, General Motors Corporation; Mr. Donald W. Bahr of the General Electric Company, Advanced Engine Group; and Dr. Joseph Faucher of Pratt and Whitney Aircraft, Commercial Products Division, for their assistance and technical contributions given during the preparation and review of these combustion chapters.

* Currently at Exxon Research and Engineering Company, Linden, New Jersey.

PART I

FUNDAMENTALS OF COMBUSTION

Chapter 15 of A Comprehensive Study of Aircraft Gas
Turbine Engines, edited by G. C. Oates

by:

William S. Blazowski*
AF Aero Propulsion Laboratory
AF Wright Aeronautical Laboratories
Wright-Patterson AFB, Ohio 45433

* Currently at Exxon Research and Engineering Company, Linden, New Jersey.

TABLE OF CONTENTS

CHAPTER 15 FUNDAMENTALS OF COMBUSTION

	<u>Page</u>
15.0 INTRODUCTION	15-1
15.1 CHEMISTRY	15-1
15.1.1 Reaction Rate	15-1
15.1.2 Chemical Equilibrium	15-2
15.1.3 Hydrocarbon Chemistry	15-3
15.2 THERMODYNAMICS	15-5
15.2.1 Energy Release and Flame Temperature	15-5
15.2.2 Important Flame Temperature Dependencies	15-7
15.3 GAS DYNAMICS AND DIFFUSION PROCESSES	15-9
15.3.1 Premixed Laminar Flames	15-9
15.3.2 Diffusion Controlled Combustion	15-10
15.3.3 Turbulence Effects	15-11
15.3.4 Perfectly Stirred Reactor	15-12
15.4 COMBUSTION PARAMETERS	15-14
15.4.1 Combustion Efficiency	15-14
15.4.2 Flame Stabilization	15-14
15.4.3 Ignition	15-15
15.5 JET FUELS	15-17
15.5.1 Combustion Characteristics	15-17
15.5.2 Common Jet Fuels	15-17
15.6 SUMMARY	15-18
15.7 BIBLIOGRAPHY AND REFERENCES	15-19
15.7.1 Bibliography	15-19
15.7.2 References	15-20

LIST OF ILLUSTRATIONS

CHAPTER 15 FUNDAMENTALS OF COMBUSTION

	<u>Page</u>
15.0.1 The Interdisciplinary Nature of Combustion Technology	15-1
15.1.1 Concentration Variations During the Course of a Reaction	15-2
15.1.2 Equilibrium Constants for Important Dissociation Reactions	15-3
15.1.3 Equilibrium CO and H ₂ Concentration Dependence on Temperature	15-4
15.1.4 Hydrocarbon Combustion Chemistry Schematic	15-4
15.2.1 Theoretical Flame Temperature Dependence on Equivalence Ratio	15-7
15.2.2 Effect of Inlet Temperature on Adiabatic Flame Temperature	15-7
15.2.3 Effect of Inlet Temperature on Stoichiometric Flame Temperature	15-8
15.2.4 Effect of Pressure on Stoichiometric Flame Temperature	15-8
15.2.5 Combustor Exit Total Temperature for Jet A Fuel and Arbitrary Pressure (Working Chart)	15-8
15.2.6 Effect of Vitiation on Stoichiometric Flame Temperature	15-9
15.3.1 Flame Velocities of Paraffin-Oxygen Mixtures at One Atmosphere Pressure and Room Temperature	15-10
15.3.2 Diffusion Flame Characteristics	15-10
15.3.3 Simplified Representation of a Turbine Combustion System	15-12
15.3.4 Perfectly Stirred Reactor Operating Conditions	15-13
15.3.5 Stirred Reactor Stability Dependence on Equivalence Ratio	15-13
15.4.1 Flammability Characteristics for a Kerosene-Type Fuel in Air at Atmospheric Pressure	15-15
15.4.2 Physical Processes in Flameholding	15-15
15.4.3 Ignition Delay Times for Practical Fuels	15-16
15.4.4 Minimum Ignition Energies	15-16
15.5.1 Distillation Characteristics of Common Jet Fuels	15-17

LIST OF TABLES

CHAPTER 15 FUNDAMENTALS OF COMBUSTION

	<u>Page</u>
15.1.1 Hydrocarbon Oxidation Kinetics Scheme	15-5
15.3.1 Turbulent Flame Theories	15-12
15.3.2 Importance of Turbulence to Chemical Reactions -- Values of $(E/RT)^{-2}$	15-13
15.4.1 Flammability Limits in Air at Atmospheric Pressure and Room Temperature	15-15
15.4.2 Spontaneous Ignition Temperatures	15-16
15.5.1 Heats of Combustion and Formation	15-18
15.5.2 Important Jet Fuel Properties	15-19

15.0 INTRODUCTION

Background information necessary to the understanding of aircraft turbine engine combustion systems is distinctly different from that applying to diffusers, rotating machinery, or nozzles and a separate discussion of fundamentals is warranted. The purpose of this chapter is to review the fundamental concepts important to aeropropulsion combustion. Two additional chapters will consider the practical application of this information to mainburners (Chapter 20) and afterburners (Chapter 21).

While large volumes can be written on the subject of aeropropulsion combustion, the scope of this chapter is limited to highlighting key information. The difficult task of deciding which information to include was accomplished by adhering to the objective that the reader be provided that material necessary for understanding the combustion system's operating principles, performance parameters, and limitations. The reader contemplating aeropropulsion combustion as an area of specialization should develop a more thorough background and is referred to a number of readily available texts listed in the bibliography to this chapter (Section 15.7.1).

Some of combustion involve interdisciplinary investigations requiring consideration of three normally separate topics: chemistry, thermodynamics, and gas dynamics. Interrelationships between these areas, shown schematically in Figure 15.0.1, require combustion engineers and scientists to develop a fundamental understanding of each topic. A number of sub-topics in each of these areas have been listed to further describe the broad scope of subject matter involved. Each of these subjects will be addressed in this chapter.

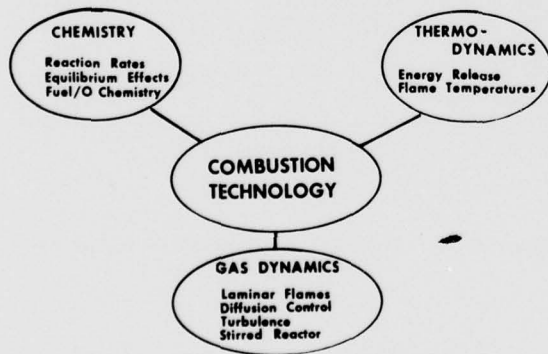

Figure 15.0.1 The Interdisciplinary Nature of Combustion Technology.

The information to be presented in this chapter is organized into five further sections. As might be expected, the first three consider chemistry, thermodynamics, and gas dynamics. The fourth involves discussion of combustion parameters of importance to the combustor designer. Finally, the combustion properties of jet fuels are briefly described.

15.1 CHEMISTRY

Three combustion chemistry topics will be discussed in this section. The first, chemical reaction rate, addresses fundamental concepts vital to all of chemical kinetics. Important dependencies of reaction rate on thermodynamic conditions, especially temperature, will be addressed. The second topic, chemical equilibrium, is of importance in relation to the understanding of and ability to analyze high temperature combustion systems. Finally, the current understanding of practical hydrocarbon fuel combustion chemistry will be reviewed. Understanding of the sequence of chemical processes leading to H₂O and CO₂ production allows the explanation of many practical combustion characteristics.

15.1.1 Reaction Rate

One of the most basic concepts of chemistry involves the law of mass action which relates the rate of a reaction, or the time rate of change of the reactant species concentration, to the concentrations of reactive species. This can be illustrated with the use of the following generalized chemical reaction:

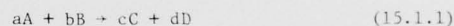

In this example, *a* moles of molecule A combine with *b* moles of molecule B to form *c* and *d* moles of products C and D. The reactant stoichiometric coefficients of the atomic balance equation (*a* and *b*) are also called the reaction "molecularity". The law of mass action states that the rate of reaction is expected to be proportional to the product of the concentrations of reactant species raised to their respective stoichiometric coefficients. For this example, the rate of forward reaction, *r_f*, would be:

$$r_f = k_f [A]^a [B]^b \quad (15.1.2)$$

The brackets, [], correspond to the molar concentration (moles/volume) of the molecular species indicated. *k_f* is the rate coefficient for the forward reaction.

Note that the rate of forward reaction, *r_f*, could be representative of either rate of disappearance of the reactants A and B or the rate of formation of products C and D. These four rates are interrelated by the stoichiometric coefficients *a*, *b*, *c*, and *d*. For example, if *r_f* were representative of the rate of disappearance of A, the following relationships would be valid:

$$r_f = - \frac{d[A]}{dt} = - \frac{b}{a} \frac{d[B]}{dt} = \frac{c}{a} \frac{d[C]}{dt}$$

$$= \frac{d}{a} \frac{d[D]}{dt} \quad (15.1.3)$$

The variable t represents time.

There is analytical justification for the observed reactant concentration dependencies of the law of mass action. An analysis based on the assumption that product formation can only occur after collision of reactant molecules predicts the same concentration dependencies as described in Equation 15.1.2. The rate coefficient in Equation 15.1.2, k_f , appropriately converts the results of collision theory to yield the units of reaction rate. In addition, k_f accounts for reaction rate dependencies due to variations in molecular energy levels and in the geometrical orientation of colliding molecules.

For many reactions of importance to combustion systems, k_f is a strong function of temperature. The temperature dependence of the molecular collision rate is minor ($T^{1/2}$) and has only a small influence on k_f . The predominant temperature dependence is a result of the necessity for molecular collisions to occur with sufficient "force" to overcome any energy barrier necessary for reactant molecules to undergo conversion to products. Physically, the formation of an activated complex is assumed to be necessary for successful conversion of colliding reactants to products. The height of the energy barrier, the energy necessary to form the activated complex, is often termed the activation energy, E_a . Not all of the colliding reactant molecules will have sufficient energy and only a fraction of the collisions will be successful. Since molecular energy distribution can be described by Boltzman statistics, the fraction of collisions which are successful is $\exp(-E_a/R)$ where R is the universal gas constant and the subscript refers to the forward reaction.

The geometrical misalignment of reactant molecules during collision can also prevent conversion to products; only a fraction of the collisions occurring with sufficient energy will be successful. Consideration of the "steric factor" is a final necessary aspect in analysis of the reaction rate coefficient. This factor can be thought of as a means of compensating for collisional inefficiencies due to the peculiarities of geometrical alignment necessary for successful reaction.

An important expression for reaction rate is obtained by combining the reaction rate coefficient dependencies discussed above with Equation 15.1.2. The forward rate of the general reaction described in Equation 15.1.1 is:

$$r_f = - \frac{d[A]}{dt}$$

$$= [A]^a [B]^b C_f(T) \exp(-E_a/R) \quad (15.1.4)$$

where C_f includes the steric factor and the necessary constants to convert collision rate to reaction rate. The strong exponential nature of the reaction rate dependence on temperature was first recognized by Arrhenius. Equation 15.1.4

with the pre-exponential factor taken as temperature independent (i.e., not including the T^2 dependence) is called the Arrhenius equation. Equation 15.1.4 itself is said to be the modified Arrhenius relationship.

It should be noted that the rate dependency given by Equation 15.1.4 is only correct in cases where the written stoichiometric equation represents the entire sequence of events leading to product formation. As will be discussed in Section 15.1.3, combustion of a practical hydrocarbon fuel involves many complex chemical reaction steps before formation of final products, CO_2 and H_2O . In cases where the stoichiometric equation does not describe the entire reaction sequence, the dependencies of the reaction rate on reactant concentration may not correspond to the molecularity and even fractional "reaction orders" may be observed. Nevertheless, the form of Equation 15.1.4 is valid for each individual reaction step of the complex sequence.

15.1.2 Chemical Equilibrium

As a reaction like that described in Equation 15.1.1 proceeds, changes of concentration with time occur as illustrated in Figure 15.1.1. When the concentrations of products C and D become significant, backward or reverse reaction (i.e., conversion of products back to reactants) can become important. The rate of backward reaction, r_b , may be analyzed in the same manner as in the case of forward reaction (Equation 15.1.2) to yield the following relation:

$$r_b = k_b [C]^c [D]^d \quad (15.1.5)$$

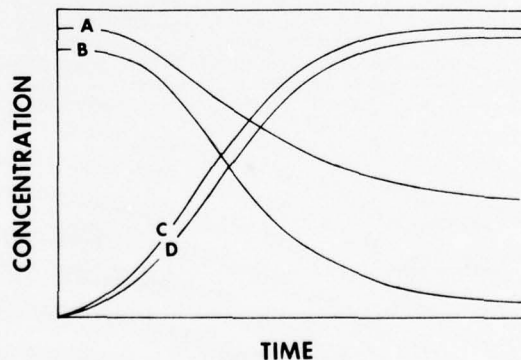

Figure 15.1.1 Concentration Variations During the Course of a Reaction.

In recognition of the existence of both forward and reverse reactions, the more appropriate convention for expressing the general chemical system described in Equation 15.1.1 is:



Because reverse reactions always exist to some extent, concentrations of A and B will eventually decrease to some finite, non-zero values such that rates of forward and reverse reactions are equal. These equilibrium concentrations are the asymptotes of Figure 15.1.1. Note that the more general case where the reactants concentrations are not in exact stoichiometric proportions has been illustrated in Figure 15.1.1 which corresponds to the situation of a large excess of reactant A.

The equilibrium concentrations can be determined from Equations 15.1.2 and 15.1.5. At equilibrium, the rate of disappearance of reactant (Equation 15.1.2) will be entirely balanced by the reactant formation rate (Equation 15.1.5). Consequently, the equilibrium condition is $r_f = r_b$ or:

$$k_f [A]^a [B]^b = k_b [C]^c [D]^d \quad (15.1.7)$$

Rearranging yields the following useful expression:

$$\frac{k_f}{k_b} = \frac{[C]^c [D]^d}{[A]^a [B]^b} \quad (15.1.8)$$

Because k_f and k_b are functions of temperature only, Equation 15.1.8 provides a convenient means of relating equilibrium concentration to mixture temperature. The ratio k_f/k_b is known as the equilibrium constant based on concentration, K_C . An additional equilibrium constant based on mole fractions, K_X , can also be developed.

An even more familiar means of characterizing equilibrium involves the partial pressure equilibrium constant, K_P . Partial pressure is a concept in which the total mixture pressure is envisioned as a sum of pressure contributions from each of the mixture constituents. The partial pressure of each constituent is the fraction of the total pressure corresponding to the mole fraction of that compound. The equilibrium constant defined in terms of partial pressure is:

$$K_P = \frac{(P_C)^c (P_D)^d}{(P_A)^a (P_B)^b} \quad (15.1.9)$$

where P_A , P_B , P_C , and P_D are the partial pressures of each constituent. By convention, these pressures are always expressed in atmospheres when used in equilibrium chemistry calculations.

Both K_C and K_P are functions of temperature only. The temperature dependencies can be deduced from Equations 15.1.4 and 15.1.7:

$$\frac{[A]^a [B]^b}{[C]^c [D]^d} C_f T^{\frac{1}{2}} \exp(-E_{af}/RT) = C_b T^{\frac{1}{2}} \exp(-E_{ab}/RT) \quad (15.1.10)$$

which can be reduced to:

$$K_C \text{ or } K_P \sim \exp\left(\frac{E_{ab} - E_{af}}{RT}\right) \quad (15.1.11)$$

Consequently, the equilibrium constant may have a strong, exponential temperature dependency.

In hydrocarbon-air combustion applications, two equilibrium relations are of paramount importance. They are the dissociations of CO_2 and H_2O :

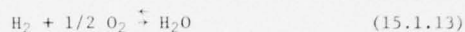
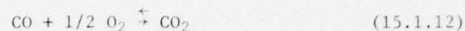

Mathematical treatment of these equilibrium relationships is often simplified by the use of the water gas reaction:

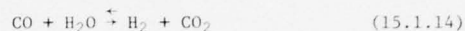

It should be noted that this is not a third independent relationship but a linear combination of Equations 15.1.12 and 15.1.13. Partial pressure equilibrium constants for each of these three reactions are illustrated in Figure 15.1.2 (data from Reference 15.1 have been utilized). Note the relative temperature insensitivity of the water gas equilibrium constant.

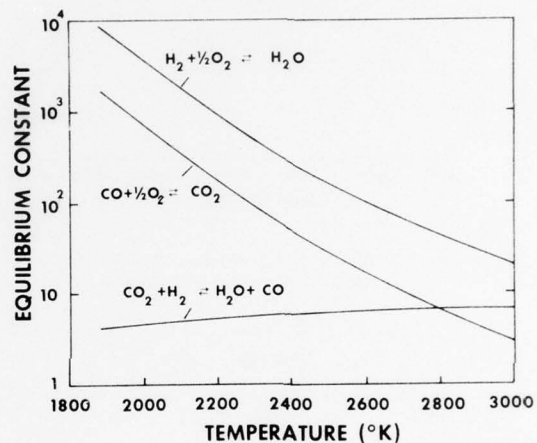

Figure 15.1.2 Equilibrium Constants for Important Dissociation Reactions.

Since the maximum chemical energy is released from a hydrocarbon fuel upon conversion to CO_2 and H_2O , dissociation of either of these products results in a decrease of energy released. As will be shown in Section 15.2, equilibrium flame temperature is strongly influenced by dissociation. Because of the temperature sensitivity of the equilibrium constants, dissociation is more pronounced at higher flame temperatures. Figure 15.1.3 illustrates the effect of final mixture temperature on dissociation using the example of stoichiometric combustion of a C_nH_{2n} type fuel with air at one atmosphere. The influence of final mixture temperature on CO and H_2 concentration in the combustion product is pronounced.

15.1.3 Hydrocarbon Chemistry

The sequence of events occurring during combustion of a practical hydrocarbon fuel is extremely complex and not understood in detail. Major aspects of hydrocarbon combustion chemistry involve hydrocarbon pyrolysis and partial oxidation to H_2 and CO , chain branching reactions resulting in H_2 consumption, and CO oxidation by radicals generated during chain branching. Each of these reaction steps is schematically illustrated in Figure 15.1.4. Note that the chronology of these processes is schematically indicated by the

flow of mass through the reaction steps. Each process is individually described below.

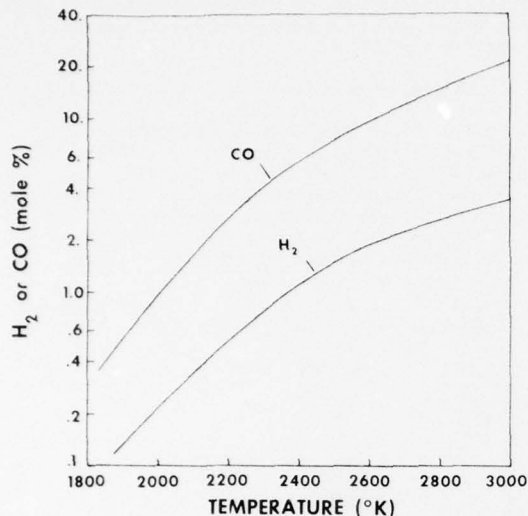

Figure 15.1.3 Equilibrium CO and H₂ Concentration Dependence on Temperature

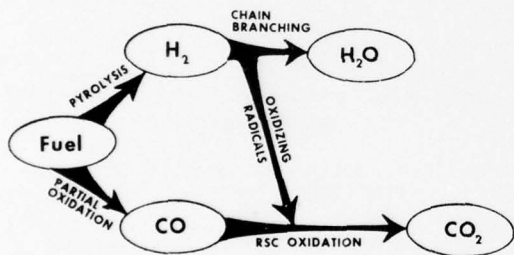

Figure 15.1.4 Hydrocarbon Combustion Chemistry Schematic.

Pyrolysis is the term given to the process by which fuel molecules are broken into smaller fragments due to excessive temperature and partial oxidation. This molecular destruction is accomplished during the first phase of the combustion process. The predominant resulting products are hydrogen and carbon monoxide. Little detailed information is available concerning the chemistry of these processes for practical fuels--large hydrocarbons with molecular weights of 50 to 200. It is well-recognized that hydrocarbon structure and its influence on the pyrolysis chemistry affects the combustion process. For example, low fuel hydrogen concentration leads to excessive carbon particle formation in the early stages of combustion.

Edelman (Ref. 15.2) has developed a single-step quasi-global model to characterize the pyrolysis and partial oxidation of any practical hydrocarbon fuel. His approach is to characterize the kinetics of the numerous complex chemical reactions resulting in production of H₂ and CO by a single reaction step. An Arrhenius type expression has been fitted to experimental data involving variations in temperature and pressure as well as fuel

and oxygen concentration. Edelman's result is:

$$\frac{d[C_{nH_m}]}{dt} = \frac{5.52 \times 10^8 T}{P^{.825}} [C_{nH_m}]^{1/2} \cdot [O_2] \exp(-24,400/RT) \quad (15.1.15)$$

where concentrations are expressed in moles/cc, T in °K, and P in atmospheres. The activation energy of 24,400 is in the units cal/g mole°K. Although this expression has proven to be useful in some combustion models, additional effort is required to determine chemical kinetic differences between hydrocarbon fuel types and to study pyrolysis mechanisms in mixtures. Further, the interface between fuel pyrolysis and carbon particulate formation requires additional study.

The products of pyrolysis are reduced state compounds (RSC). Oxidation of these species is better understood than their formation. The important oxidation reactions for the reduced-state compounds are of the general form:



where RSC = reduced-state compound
OR = oxidizing radical
OSC = oxidized-state compound
RR = reducing radical.

The rate of oxidation of the RSC may be assumed to be given by the appropriate Arrhenius controlled mechanism.

While reactions of the nature described by Equation 15.1.16 play a role in consuming the H₂ formed during the pyrolysis process, many gross characteristics of hydrocarbon combustion are a result of other chemical reactions which involve "chain branching." This type of reaction sequence involves the production of additional radical species during the process. In the case of the H₂ oxidation process, the important chain branching reactions are:

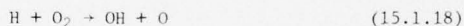
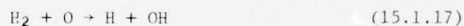

Note that in either reaction a single radical (O or H) results in the production of two radicals (H + OH or OH + O). This type of reaction has the potential of producing large quantities of radical species. In portions of the combustion zone having high H₂ concentration, radical species can reach levels far in excess of equilibrium. During this process, OH radicals also participate in RSC reactions (Equation 15.1.16) to produce H₂O from H₂.

Carbon monoxide consumption is controlled by the following RSC reaction:

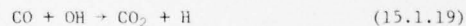

Since the activation energy of the reaction indicated by Equation 15.1.19 is generally low (only a few kcal/g-mole) the carbon monoxide oxidation rate is predominantly influenced by OH concentration. As previously noted, this quantity is controlled by the chain branching mechanism. Nevertheless, a common method of approximating radical concentration in a RSC reaction involves

assuming local or partial equilibrium. This type of approach has been used in CO oxidation studies by Howard et al. (Ref 15.3). Because the functional relationship between equilibrium OH concentration and temperature is exponential (Equation 15.1.11), an Arrhenius like dependence can be written for a quasi-global $O_2 + CO$ reaction in the presence of H_2O . Howard, et al. determined:

$$-\frac{d[CO]}{dt} = k_0 [CO] [O_2]^{1/2} [H_2O]^{1/2} \exp\left(\frac{-30,000}{RT}\right) \quad (15.1.20)$$

where k_0 is a constant = 1.3×10^{14} cc/mole sec. This assumption is not necessarily in conflict with the knowledge that higher-than-equilibrium free radical concentrations may be produced by the reactions of Equations 15.1.7 and 15.1.18. CO oxidation is much slower than H_2 consumption and, in non-recirculating systems, occurs predominantly after the chain branching H_2 reactions are largely complete. However, gas turbine combustion systems do employ recirculation and the suitability of this assumption for that application is not straightforward.

The production of H_2O and especially CO_2 through the RSC reactions described above results in the release of a great deal of energy. Consequently, the rate of consumption of CO and the predominant energy release rate are strongly connected. Experience has shown that combustion characteristics influenced by the principal heat release processes (e.g. flame propagation) are correlated by considerations of Equations 15.1.19 and 15.1.20. On the other hand, those characteristics dependent on fuel breakdown/pyrolysis (e.g., ignition delay) are better correlated by consideration of Equation 15.1.15.

The above discussion provides only a simplified description of the complex chemistry of hydrocarbon combustion. Additional detailed treatment has recently been undertaken in efforts to predict pollutant emissions from combustion systems. Table 15.1.1 illustrates one of the more complex schemes which has been utilized in Reference 15.4.

15.2 THERMODYNAMICS

This section is intended to describe the thermodynamic relationships of importance in evaluating the effect of chemical energy release in combustion systems. The first subsection highlights application of the first law of thermodynamics, offers straightforward evaluations of flame temperature dependencies, and describes methodology used in calculating flame temperature. The second addresses important flame temperature dependencies in the practical situation of jet fuel/air combustion.

15.2.1 Energy Release and Flame Temperature

The first law of thermodynamics, energy conservation, is an important factor in any analysis of combustion systems. Adiabatic, flowing, constant pressure combustion systems, approximated by both main burners and afterburners of gas turbines, can be analyzed using conservation of total enthalpy. In this case, total enthalpy includes sensible (or thermal), chemical, and kinetic contributions.

TABLE 15.1.1: Hydrocarbon Oxidation Kinetics Scheme (From Reference 15.4)

- (1) $C_8H_{16} + O_2 \rightarrow 2C_4H_8O$
- (2) $C_4H_8O + O_2 \rightarrow HO_2 + CO + CH_3 + C_2H_4$
- (3) $C_8H_{16} + OH \rightarrow H_2CO + CH_3 + 3C_2H_4$
- (4) $CH_3 + O \rightarrow H_2CO + H$
- (5) $CH_3 + O_2 \rightarrow H_2CO + OH$
- (6) $H_2CO + OH \rightarrow H_2O + CO + H$
- (7) $C_2H_4 + O_2 \rightarrow 2H_2CO$
- (8) $C_2H_4 + OH \rightarrow CH_3 + H_2CO$
- (9) $CH_3 + H_2 \rightarrow CH_4 + H$
- (10) $C_2H_4 \rightarrow C_2H_2 + H_2$
- (11) $C_2H_2 + OH \rightarrow CH_3 + CO$
- (12) $2H + M \rightarrow H_2 + M$
- (13) $2O + M \rightarrow O_2 + M$
- (14) $OH + H + M \rightarrow H_2O + M$
- (15) $H + O_2 \rightarrow OH + O$
- (16) $O + H_2 \rightarrow OH + H$
- (17) $H + H_2O \rightarrow H_2 + OH$
- (18) $O + H_2O \rightarrow 2OH$
- (19) $CO + OH \rightarrow CO_2 + H$
- (20) $HO_2 + M \rightarrow H + O_2 + M$
- (21) $HO_2 + H \rightarrow 2OH$

$$h_t = h_s + \left(\frac{f/a}{f/a + 1}\right) \psi + \frac{u^2}{2J} \quad (15.2.1)$$

where: h_t = total enthalpy (Kcal/kg)
 h_s = sensible enthalpy (Kcal/kg)
 f/a = mass ratio of fuel to air
 ψ = chemical energy (Kcal/kg fuel)
 u = flow velocity (m/sec)
 J = mechanical equivalent of heat =

$$\frac{4186 \text{ joule}}{\text{Kcal}}$$

Most frequently, standard heats of formation are used to determine the chemical energy released during a combustion process. The standard heat of formation, h_f , represents the energy addition necessary for constant pressure formation of a compound from its elements in their natural state at 25°C. The energy required to accomplish any reaction can be calculated by algebraically summing the heat of formation contributions of products minus reactants.

$$(\Delta h_r)_{25^\circ\text{C}} = \sum x_i (h_f)_i - \sum x_j (h_f)_j \quad (15.2.2)$$

where: Δh_r = heat of reaction at 25°C

x_i = stoichiometric coefficients of product compounds

x_j = stoichiometric coefficients of reactant compounds.

If Equation 15.2.2 is applied to a complete oxidation process of a hydrocarbon where all fuel hydrogen is converted to H₂O and all fuel carbon is converted to CO₂, the heat of combustion, Δh_c , will be calculated. Note that this result is normally a large negative value (i.e. the reaction is strongly exothermic).

The amount of heat required to accomplish a reaction, Δh_r , is a function of reaction temperature. Heat required at temperature T₁, rather than 25°C would be:

$$(\Delta h_r)_{T_1} - (\Delta h_r)_{25^\circ\text{C}} = (h_{sp} - h_{sr})_{T_1} - (h_{sp} - h_{sr})_{25^\circ\text{C}} \quad (15.2.3)$$

where h_{sp} and h_{sr} are the product and reactant sensible enthalpies. Heats of combustion are generally greater (i.e. less energy is released) as temperature is increased.

With the important exception of the afterburner nozzle, the kinetic contribution to total enthalpy in gas turbine combustion systems is relatively small. In such a case, the relationship between the energy released due to combustion and the final flame temperature is:

$$-(\Delta h_c)_{T_1} = (h_{sp})_{T_2} - (h_{sp})_{T_1} = \int_{T_1}^{T_2} C_p dT \quad (15.2.4)$$

where C_p is the temperature-dependent specific heat of the combustion products and the heat of combustion at temperature T₁ is calculated using Equation 15.2.3. In this flame temperature calculation, the heat generated in forming combustion products at temperature T₁ can be envisioned as an energy source for constant pressure heating of the combustion products from T₁ to T₂.

The term ψ in Equation 15.2.1 is a temperature invariant representation of a fuel's chemical energy. It may be calculated using the following relationship:

$$\psi = (-\Delta h_c)_{25^\circ\text{C}} + (h_{sp} - h_{sr})_{25^\circ\text{C}} \quad (15.2.5)$$

The concept of chemical energy in conjunction with Equation 15.2.1 provides a second method for determining final flame temperature (Ref. 15.1). Conservation of total enthalpy, for the case where kinetic contributions are negligible, results in the following expression:

$$(h_{sr})_{T_1} + \left(\frac{f/a}{1 + f/a}\right)\psi = (h_{sp})_{T_2} \quad (15.2.6)$$

It can be shown that the solutions for Equations 15.2.5 and 15.2.6 and Equations 15.2.3 and 15.2.4 are identical.

The case where a hydrocarbon fuel is completely reacted to CO₂ and H₂O results in the maximum achievable flame temperature, as the maximum energy is released upon formation of these products. Note that this can only be achieved for a lean mixture (i.e., more oxygen necessary than required for stoichiometric reaction). Conversion to H₂O, CO₂, and CO is often assumed for rich mixtures, as the conversion of H₂ to H₂O is much more rapid than CO oxidation (see Section 15.1.3). The temperature that would result if the reaction were complete is defined as the "theoretical flame temperature." Because of incomplete combustion, energy losses, and the effects of CO₂ and H₂O dissociation, the theoretical flame temperature is never achieved in real combustion systems. Nevertheless, consideration of this simplified flame temperature concept reveals important trends dictated by the first law of thermodynamics.

Equations 15.2.4 and 15.2.6 relate temperature rise to heat release due to combustion. For a given amount of energy release it is apparent that the final flame temperature will increase with initial temperature. Secondly, since for lean mixtures the heat released will be proportional to the amount of fuel burned per mass of mixture, it is implied that T₂ will increase directly with fuel-air ratio. However, when the mixture ratio exceeds stoichiometric CO, and possibly H₂ and unburned fuel, will be present in the exhaust products and a decrease in flame temperature trend will result. Consequently, this analysis indicates a maximum flame temperature for stoichiometric conditions. These trends are illustrated in Figure 15.2.1. Rather than considering fuel-air ratio, the equivalence ratio, ϕ , has been used in this illustration. Equivalence ratio is the fuel-air ratio of consideration divided by the stoichiometric fuel-air ratio:

$$\phi = \frac{f/a}{(f/a)_{\text{stoichiometric}}} \quad (15.2.7)$$

Values of ϕ less than unity correspond to lean operation while those greater than unity correspond to rich combustion.

Accurate flame temperature prediction requires consideration of dissociation effects and variable specific heats. Iterative solution of at least four simultaneous equations is involved. The equations are:

- a) stoichiometric chemical equation (mass and atomic conservation)
- b) energy conservation
- c) CO₂ dissociation
- d) H₂O dissociation.

Additional equilibrium relationships may be added to improve accuracy and predict concentrations of NO, NO₂, O, H, OH, N, etc. Note further that the water gas equilibrium equation is usually substituted for either c) or d) to simplify mathematical procedures (see Section 15.1.2).

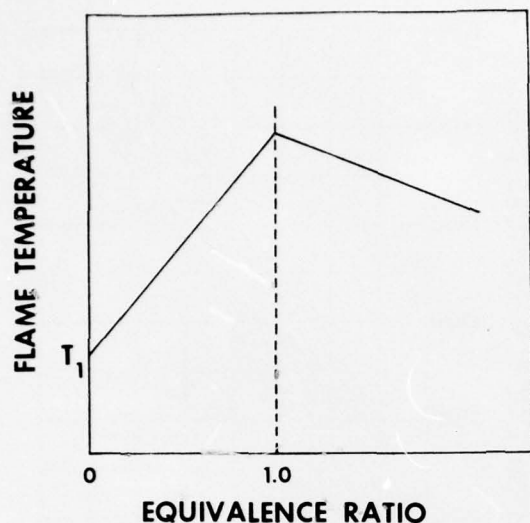

Figure 15.2.1: Theoretical Flame Temperature Dependence on Equivalence Ratio.

A number of methods of solving these equations are practical. One technique involves assuming a flame temperature and calculating species concentrations using the equilibrium relationships. The values are then used to check for balance of the energy equation. Additional guesses and iterations are made till a temperature is determined such that the conservation of energy is satisfied within acceptable limits.

Because of the involved nature of these calculations, detailed tabulated results and computer programs have been established to assist combustion scientists and engineers. Some of the early tabulated calculations are the subject of Reference 15.5 while the most popular of currently available computer programs for this purpose is described in Reference 15.6.

15.2.2 Important Flame Temperature Dependencies

This sub-section presents calculated flame temperature results of practical importance to turbine engine combustion. Important variables to be examined are fuel-air ratio, initial pressure and temperature, and mixture inert concentration.

The simplified relationship between calculated constant pressure adiabatic flame temperature and mixture ratio shown in Figure 15.2.1 is significantly altered when the detailed effects of dissociation and specific heat variations are included. This is illustrated in Figure 15.2.2 which shows results for combustion of Jet A with air at 800°K and 25 atm (representative of modern combustor inlet conditions at 100% power operation). The difference between theoretical and actual flame temperature as the mixture ratio approaches stoichiometric is due to the presence of significant CO and H₂ concentrations at the higher temperatures (see Figure 15.1.3).

In addition, note that dissociation causes the peak flame temperature to occur at slightly rich conditions.

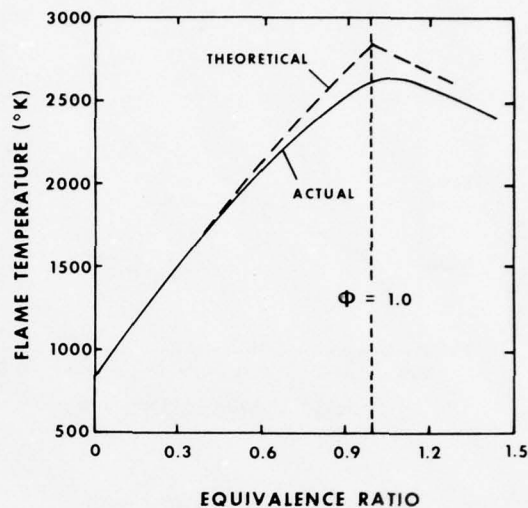

Figure 15.2.2: Effect of Equivalence Ratio on Adiabatic Flame Temperature.

An understanding of the influences of initial pressure and temperature on flame temperature is important to the combustion engineer, as testing is frequently accomplished at scaled operating conditions. Figure 15.2.3 illustrates the relationship between stoichiometric flame temperature and inlet temperature at a pressure of 25 atmospheres using Jet A fuel. Note that only one-half of an increase in inlet temperature is translated to flame temperature at these conditions. Again, the non-linearity is primarily due to the strong temperature dependence of the equilibrium constants for CO₂ and H₂O dissociation. The effect of pressure is illustrated in Figure 15.2.4. An increase in pressure at constant initial temperature results in an increase in flame temperature. This dependence can be explained by examining the form of the H₂O and CO₂ dissociation equations. In both cases, dissociation requires an increase in the total number of moles of product. The physics of the equilibrium process, as embodied in Equations 15.1.8 and 15.1.9, cause an increase in pressure to result in a shift to less total moles of product -- in this case less dissociation. The increased amounts of H₂O and CO₂ in the combustion products result in greater flame temperature.

Consideration of main combustor exit temperatures can be somewhat simplified from the complexities of the foregoing discussion. Most of the variations discussed with respect to Figures 15.2.2 - 15.2.4 occur at the highest values of flame temperature. Since main burner exit temperatures are generally below 1750°K, the inlet temperature and pressure effects of dissociation are far less pronounced. Figure 15.2.5 illustrates the relationship between fuel-air ratio and total

temperature which may be used for any pressure at flame temperatures less than 1750°K.

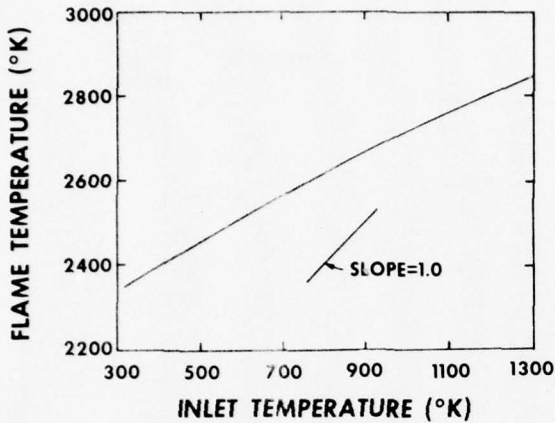

Figure 15.2.3 Effect of Inlet Temperature on Stoichiometric Flame Temperature.

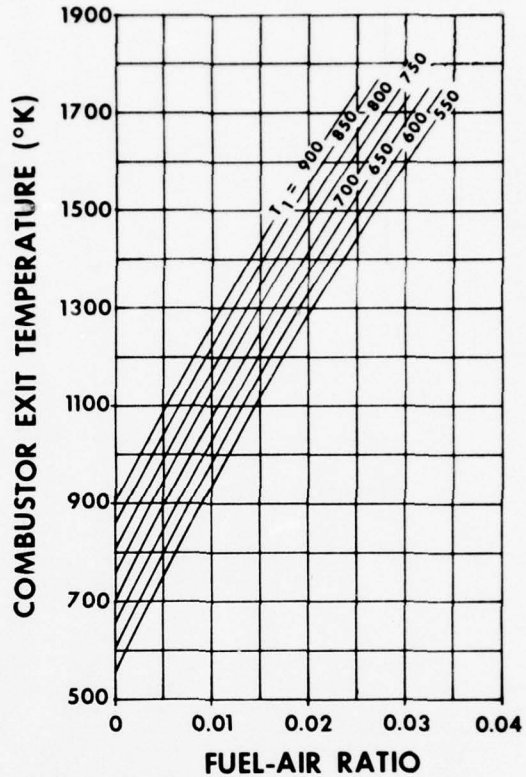

Figure 15.2.5 Combustor Exit Total Temperature for Jet A Fuel and Arbitrary Pressure (Working Chart).

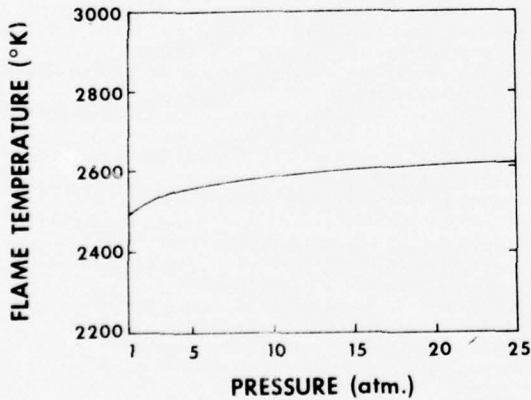

Figure 15.2.4 Effect of Pressure on Stoichiometric Flame Temperature.

Another important factor influencing flame temperature is oxygen concentration. Two very important instances of combustion with an O_2 concentration less than that of air are vital to the combustion engineer. While a gas turbine engine main burner encounters air with approximately 21% O_2 in actual operation (preheating being accomplished by the compressor), testing is sometimes conducted using vitiated air -- inlet temperature requirements are satisfied by pre-combustion rather than compression or indirect heating using a heat exchanger. The other very important example of vitiated combustion is, of course, the afterburner. In this case, some of the energy previously added by the compressor and main burner combustion has been extracted by the turbine. Consequently, temperatures in stoichiometric zones of the main combustor significantly exceed maximum achievable temperatures within the afterburner.

A means of evaluating the effect of vitiation on flame temperature is to consider oxygen availability. Vitiated combustion is characterized by abnormally high H_2O and CO_2 concentrations and lower O_2 concentrations. Therefore, the effect of vitiation is to reduce the amount of fuel per mass of mixture which can

be stoichiometrically burned; reduced final flame temperature would be predicted by Equations 15.2.4 and 15.2.6. Figure 15.2.6 illustrates the effect of reduced oxygen concentration as a function of the degree of vitiation. These calculations were performed with combustor inlet conditions of 900°K and one atmosphere pressure, values typical of turbine exit conditions. The results include the effects of dissociation.

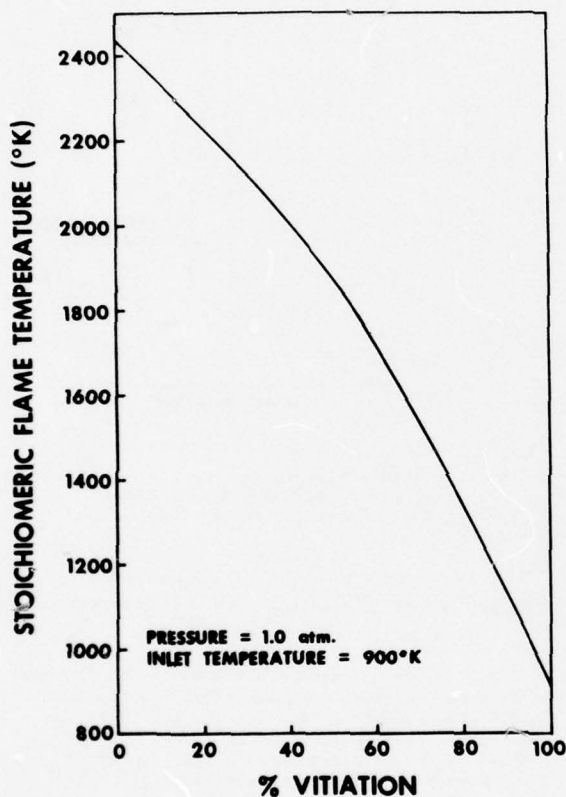

Figure 15.2.6 Effect of Vitiation on Stoichiometric Flame Temperature.

15.3 GAS DYNAMICS AND DIFFUSION PROCESSES

The influences of gas dynamics and diffusion of species and heat on combustion are extremely complex. Rather than treat these involved processes in detail, this section intends to explain the impact of these phenomenon in turbopropulsion combustion and to outline the general approaches utilized to model these processes in turbine engine combustion systems. The topics of consideration include premixed laminar flame propagation, diffusion-controlled combustion, effects of turbulence on combustion processes, and the perfectly stirred reactor.

15.3.1 Premixed Laminar Flames

The simplest situation involving simultaneous treatment of combustion and gas dynamics is the premixed laminar flame. In this case, a reaction front proceeds through a uniform mixture of gaseous fuel and air with a constant propagation speed. An analysis of the mass, momentum, and energy conservation equations governing this case (called the Rankine-Hugoniot analysis) predicts two types of solutions. First, the reaction front can proceed into the unburned gases supersonically. The velocity of the burned gases with respect to the reaction front can be either subsonic (the detonation case) or supersonic (the supersonic combustion case). Secondly, the reaction front can proceed into the unburned gases subsonically. In this case, the burned gases must also be subsonic, as the supersonic case would violate the second law of thermodynamics. Subsonic flame propagation is also called deflagration.

While the Rankine-Hugoniot equations predict the existence of deflagration and relationships between the properties of burned and unburned gases, the analysis does not allow calculation of the propagation velocity, S_L . Prediction of S_L requires consideration of heat conduction and species diffusion across the reaction front. The basic thermal theory of Mallard and LeChatelier first proposed in 1883 results in the following important temperature dependence:

$$S_L \sim \exp(-E_a/2RT_f) \quad (15.3.1)$$

This temperature relationship is similar to that for reaction rate (Equation 15.1.4) except for the factor of 2 in the exponential denominator. Equation 15.3.1 is consistent with empirical flame propagation dependencies on fuel air ratio as shown in Figure 15.3.1; the highest propagation velocity is at approximately $\phi = 1$, where T_f is at its maximum value.

Variations in flame propagation rate with the hydrocarbon types of practical interest to turbopropulsion combustion are not substantial (Ref. 15.8). Practical jet fuels would be expected to behave in a manner similar to that of the fuels described in Figure 15.3.1. The pressure dependence of flame propagation is not straightforward. In mixtures with burning velocities below 50 cm/sec, S_L decreases with increasing pressure. Between 50 and 100 cm/sec S_L remains approximately constant. Above 100 cm/sec S_L increases with increasing pressure (Ref 15.8).

Across the reaction front a substantial decrease in gas densities occurs. Consequently, mass conservation requires a substantial increase in velocity. This acceleration results at the expense of some pressure drop across the front. The pressure drop is:

$$\frac{\Delta P}{P} = \gamma \left(1 - \frac{T_1}{T_F} \right) \left(\frac{S_L}{a} \right)^2 \quad (15.3.2)$$

where γ is the ratio of initial gas specific heats, T_1 is the initial temperature and a is the speed of sound in the initial mixture.

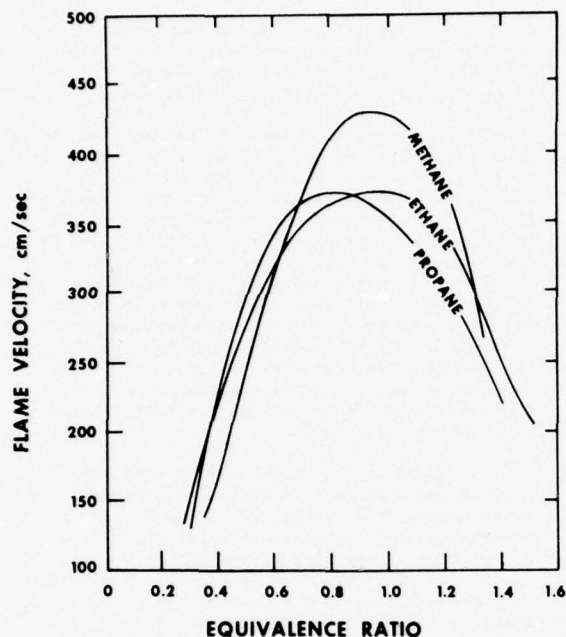

Figure 15.3.1 Flame Velocities of Paraffin-Oxygen Mixtures at One Atmosphere Pressure and Room Temperature.

This quantity represents the minimum pressure drop (usually less than 1%) a combustion system can experience in order to accomplish a given energy release.

Values of laminar flame propagation are usually no greater than 5 m/sec. Since reference velocities in modern combustion turbine engine systems are generally greater than 25 m/sec, laminar flame propagation is not considered a predominant mode of combustion. Other modes of combustion involving diffusion control, turbulent mixing, and the establishment of zones approaching perfectly stirred reactors are necessary.

15.3.2 Diffusion Controlled Combustion

In many practical devices the fuel and air are not entirely premixed prior to combustion. In these cases, reactions take place in flame zones where the influx of oxygen and fuel occur at a rate corresponding to the stoichiometric ratio. In laminar flows, the mechanism for transport of fuel and oxygen into these zones is molecular diffusion and these types of systems are called diffusion flames.

Common examples of laminar diffusion flames are the candle, a kerosene lamp, or a match; in each case the fuel and O_2 do not premix prior to the flame. An appreciation for the nature of diffusion flames may be gained by examining the early work of Burke and Schumann (Ref. 15.9) which was published in 1928. Experimentally, they utilized a system similar to that shown in Figure 15.3.2a. Fuel

enters the combustion zone through a central tube. A laminar diffusion flame, the shape of which is governed by the ratio of fuel to air flow, is established in the combustion zone.

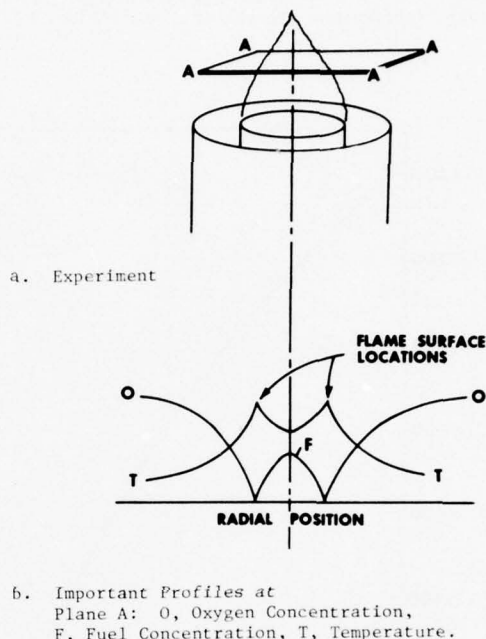

Figure 15.3.2 Diffusion Flame Characteristics.

Burke and Schumann's analysis constituted the first successful treatment of laminar diffusion flames, and it continues to represent the approach taken in modern work. They modeled the flame as an infinitely thin sheet into which fuel and oxygen flow in stoichiometric proportions. All heat release from chemical reaction occurs at this surface. This approach is equivalent to the assumption that the chemical reactions are infinitely fast compared to the diffusion processes which, therefore, control the burning rate. In order to mathematically prohibit an infinite gradient of fuel or oxygen at the flame surface (which would indicate infinite flux into the surface) it is necessary to require both fuel and oxygen concentrations to be zero at the surface. This concept of concentration and temperature profiles is illustrated in Figure 15.3.2b.

Important differences between premixed and diffusion flames center around the existence of the flame sheet. In the case of the premixed flame with no flame sheet, temperatures achieved correspond to that for constant pressure combustion at the premixture fuel-air ratio and the burning rate is controlled by the chemical kinetic rate and flame temperature (Equation 15.3.1). However, in the case of laminar diffusion flames, combustion always occurs at stoichiometric conditions at the flame sheet and the burning rate is controlled by

molecular diffusion. Moreover, the temperature at the flame does not generally correspond to the premixed constant pressure stoichiometric flame temperature. The thermodynamics at the flame sheet are strongly influenced by the rates of heat and mass transfer near the flame (i.e., mass and temperature gradients) and are not calculable through the use of a simple energy balance.

The simplifying assumption of an infinite chemical reaction rate can be eliminated through the utilization of a much more sophisticated analysis. The primary effects of including finite reaction rates are prediction of a flame of finite thickness, lesser gradients of concentration and temperature at the flame, and lower peak flame temperatures. While more accurate prediction of near-flame characteristics is achieved by the more sophisticated analysis, many important properties, notably burning rate, are predicted nearly as well with the less elaborate approach.

The instance in which the classical thin-flame theory of diffusion flames is of importance to turbine combustion systems involves fuel droplet burning. While many combustion engineers question whether droplet combustion occurs under the high temperature and turbulent conditions characteristic of high power operation, it would be likely during starting and idle operation. In this case, vaporization is caused by heat transfer from a flame surrounding the liquid droplet, assumed to be at its boiling temperature. The gaseous fuel proceeds to the flame and stoichiometrically reacts with oxygen diffusing radially inward from the surroundings. Analysis of this situation, similar to the Burke and Schumann analysis discussed above, results in the following burning rate prediction:

$$d^2 = d_0^2 - kt \quad (15.3.3)$$

where d is the fuel droplet diameter at time t , d_0 is d at $t = 0$, and k is a constant. This relationship, known as Godsave's law, predicts fuel efforts through variations in k (Ref. 15.10). The influence of convective velocity, air temperature, and oxygen concentration can also be included in determination of the value of k . Note that this relationship is also applicable to droplet evaporation without combustion, the difference being a smaller value of k .

The foregoing discussion addresses the simplified concept of fuel droplet combustion wherein the process of each individual droplet is assumed to be independent and the fuel is comprised of a single hydrocarbon component. In reality, the situation is far more complex; droplet interactions and complications of multi-component fuels cause significant departures from the simplified case discussed above (Ref. 15.11 and 15.12). The combustion engineer should utilize empirical information when available. Recent data are presented in Reference 15.12.

Diffusion-controlled combustion will also occur in the cases where fuel droplets have vaporized but not mixed with surrounding air, thus forming fuel-rich pockets, or where the gases from a rich primary zone mix with secondary air. Many of the performance characteristics of present day combustors confirm the existence and importance of such processes. However, the diffusion controlled reactions in practical gas turbine combustion systems cannot be simply treated by classical laminar

diffusion flame theory; turbulence effects are extremely important and the effects of turbulent diffusivity must be included. These will be discussed in the following subsection.

15.3.3 Turbulence Effects

Previous discussions of both premixed and diffusion controlled combustion have concentrated on laminar systems. In practice, however, the presence of turbulence has an extremely important influence on both premixed and diffusion controlled combustion.

The rate of flame propagation in a premixed system is greatly enhanced by turbulence. Most available information on this subject has been developed to improve the understanding of turbulent flame propagation in afterburners. However, turbulent flame propagation information is currently of additional importance, as low emission combustors employ a highly turbulent fuel-air mixing and vaporization zone prior to combustion (see Chapter 20). An important consideration in such systems is the possibility of "flashback" or turbulent flame propagation upstream to the fuel injection point.

Lefebvre and Reid (Ref. 15.13) have reviewed important turbulent flame propagation literature. The relationships shown in Table 15.3.1 have been cited as representative of the understanding of turbulence effects. The important parameters influencing turbulent flame propagation, S_T are:

- u' = the fluctuating component of gas velocity.
- \bar{y} = parameter describing free stream and flame generated turbulence intensity.
- λ = turbulence length scale.

Generally speaking, the turbulent flame velocity can be the order of the turbulent velocity, u' , far exceeding S_L .

Turbulence also causes increased burning rates in diffusion flames (Ref. 15.18). Analyses for turbulent diffusion flames are similar to the laminar case but use an artificially high diffusivity constant. Physically, the increased fuel/air mixing is explained as due to forced mixing of small fuel lean or fuel rich elements of gas by turbulent forces. These small elements of gas are called eddies. The analytical adjustment, called eddy diffusivity, accounts for the enhanced mixing at the reaction front. This approach is taken as a convenience and is based on empirical correlations rather than fundamental principles.

The importance of turbulence on many practical aspects of turbine engine combustion has recently been highlighted by Mellor (Ref. 15.19). He proposes a simplified model for main burner combustion in which important processes are assumed to occur in a highly turbulent diffusion flame stabilized by a recirculation zone behind a bluff body (see Figure 15.3.3). His analysis, based on characteristic times for turbulent mixing and chemical reaction and focusing on the shear layer mixing zone, has been shown to be successful in correlating a number of combustion characteristics ranging from exhaust pollutants to stability.

TABLE 15.3.1: Turbulent Flame Theories (From Reference 15.13).

Investigator	Relationships	Conclusions
Damkohler (Ref. 15.14)	$S_T = S_L + u'$ At high velocities this approaches $S_T = u'$	S_T is independent of turbulence scale. At high velocities S_T is determined solely by turbulent velocity.
Shchelkin (Ref. 15.15)	$S_T = S_L[1 + (u'/S_L)^2]^{.5}$ At high velocities this approaches $S_T = u'$	In agreement with Damkohler.
Karlovitz (Ref. 15.16)	For weak turbulence $S_T = S_L + u'$ For strong turbulence: $S_T = S_L + (2S_L u')^{.5}$ Where: $u' = \frac{S_L}{\sqrt{3}} \left(\frac{\rho_u}{\rho_b} - 1 \right)$	S_T is independent of turbulence scale. Laminar flame speed is most important parameter.
Scurlock (Ref. 15.17)	$S_T = S_L[1 + C_3(\bar{y}/\lambda)^2]^{.5}$ Where: \bar{y} is dependent on approach stream and flame generated turbulence; λ is the turbulence scale; C_3 is a constant.	S_T is dependent on laminar flame speed and turbulence scale.

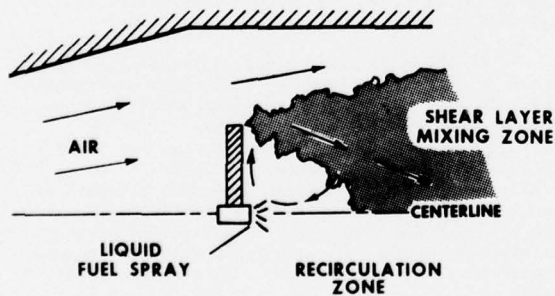

Figure 15.3.3: Simplified Representation of a Turbine Combustion System.

A final aspect of turbulence to be discussed here involves its effect on chemical reactions. During fuel-air mixing as well as in the reaction zone, the individual turbulent eddies can have widely differing values of fuel-air ratio and temperature. Because reaction rates are very sensitive to these variables (Equation 15.1.4) the turbulence characteristics can strongly influence

the rates and end products of the combustion process. Gouldin (Ref. 15.20) has performed an analysis which indicates that turbulence is of importance to chemical reactions when turbulent temperature fluctuations T' are such that:

$$\frac{\overline{(T')^2}}{\bar{T}^2} > \left(\frac{E_a}{RT} \right)^{-2} \quad (15.3.4)$$

where the bars indicate average values. Table 15.3.2 indicates $(E_a/RT)^{-2}$ for different values of E_a and \bar{T} . Turbulence can be expected to play a significant role in all cases except those involving low activation energies (<20 Kcal/g mole) and high temperatures (>2500°K). Because of the obvious difficulties in accomplishing temperature or concentration measurements on the time and length scales of interest to this subject, only limited empirical information is available to provide further explanation of this complex phenomena.

15.3.4 Perfectly Stirred Reactor

The perfectly stirred reactor (PSR) is defined as a combustion region in which reactant and product concentrations as well as temperature are completely homogeneous (Ref. 15.21, 15.22). The fuel-air mixture entering the reactor is assumed to be instantaneously mixed with the combustion products. In principle, this immediately increases the temperature of the entering reactants far beyond the initial state and provides a substantial and continuous supply of chain carriers

TABLE 15.3.2: Importance of Turbulence to Chemical Reactions -- Values of $(E_a/RT)^{-2}$

E_a (Kcal/g-mole)	T (°K)		
	1500	2000	2500
10	.09	.16	.25
20	.0225	.04	.0625
40	.0052	.01	.0156
60	.0025	.0044	.00694
80	.0014	.0025	.0039

which are of paramount importance to hydrocarbon combustion (See Section 15.1.3).

Reaction rates per unit volume are maximized in the PSR. Stabilization characteristics of practical systems -- primary zones of main combustors and regions behind flameholders of afterburners -- are often modeled using PSR analyses. A simplified version of the analysis presented in Reference 15.22 results in the following dependence of the reaction rate on key parameters:

$$\frac{m}{V} \sim \left(\frac{P}{RT_R}\right)^n \frac{(T_F - T_R)^n}{(T_F - T_U)^{n-1} (T_R - T_U)} \exp(-E_a/RT_R) \quad (15.3.5)$$

where: V = reactor volume

m = mass flow rate into the reactor

n = total reaction order

T_F = adiabatic flame temperature for complete reaction

T_R = PSR temperature

T_U = initial temperature of entering (unburned) mixture.

Figure 15.3.4 illustrates the relationship between mass burning rate and reactor temperature. These results correspond to a case where $n = 2$, $E_a = 40$ Kcal/g mole and stoichiometric combustion of a fuel yielding T_F values of 2550, 2500 and 2400°K for T_U values of 1000, 800, and 600°K. Equation 15.3.5 yields three solutions for any value of m/VP^n -- only the two highest T_R solutions are indicated in Figure 15.3.4, as the lowest T_R solution, while stable, is not of practical interest here. The mid- T_R solution is also of academic importance, as it is unstable. Considering only the highest T_R solution, the analysis indicates that the adiabatic flame temperature for complete reaction is only achieved at flow rates approaching zero. Further, a maximum value of m/VP^n is indicated and blow out is expected if a further increase is attempted. Typically, this PSR blow out point is imminent when the temperature rise above inlet conditions is 75% of that corresponding to complete combustion.

The exponential nature of reaction rates (Equation 15.1.4) is directly reflected in Equation 15.3.5. For this reason, perfectly stirred reactors have been extensively utilized for high

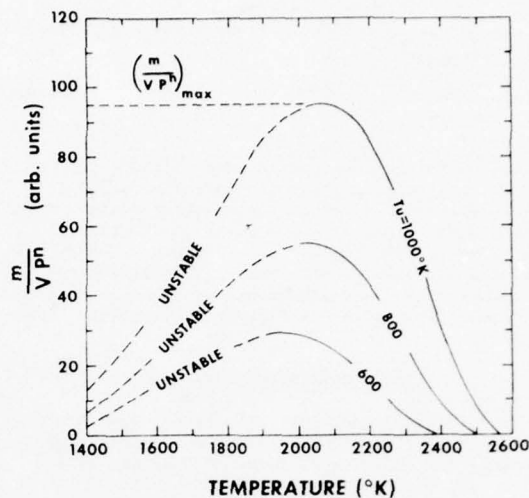

Figure 15.3.4 Perfectly Stirred Reactor Operating Conditions.

temperature chemical kinetic studies. Equation 15.3.5 also indicates the beneficial effect of higher values of T_R on stabilization. This can be achieved by higher initial mixture temperature (as shown in Figure 15.3.4) and/or an equivalence ratio closer to unity. Figure 15.3.5 illustrates the dependence of the well-stirred reactor stability region on equivalence ratio. Consequently, combustor designers strive to create primary zones which promote stabilization with an approximately stoichiometric fuel-air mixture ratio.

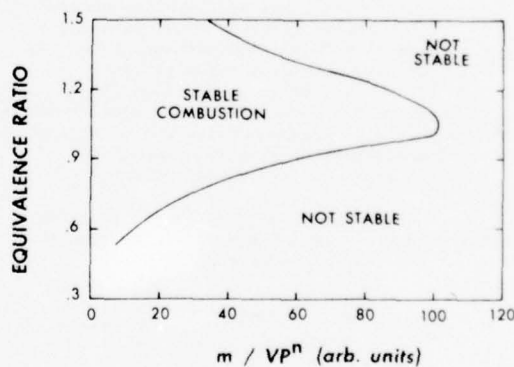

Figure 15.3.5 Stirred Reactor Stability Dependence on Equivalence Ratio.

Equation 15.3.5 can be rearranged and simplified while maintaining the most important temperature characteristics to yield the following relationship:

$$\frac{m}{Vp^n} \sim \exp^{-E_a/RT} \quad (15.3.6)$$

This relationship provides some guidance in developing a parameter with which the volumetric heat release of practical combustion systems may be judged. Following the units of Equation 15.3.6 a specific heat release rate parameter, SHRR, has been established for aircraft gas turbine combustors with the units of energy/time-pressure-volume. This topic is discussed further in Chapter 20.

15.4 COMBUSTION PARAMETERS

Three important combustion parameters will be discussed in this section. Descriptions of combustion efficiency, flame stabilization, and ignition phenomena are included.

15.4.1 Combustion Efficiency

Perhaps the most fundamental of all combustion performance characteristics is the combustion efficiency, η_c . This parameter is defined as the fraction of the maximum possible energy which has been released during a combustion process. For the case of constant pressure combustion, η_c can be expressed as:

$$\eta_c = \frac{(h_{sp})_{T_2} - (h_{sp})_{T_1}}{(h_{sp})_{T_2 \text{ ideal}} - (h_{sp})_{T_1}} \quad (15.4.1)$$

An excellent approximation of η_c can be made by assuming that the product specific heat is independent of temperature:

$$\eta_c = \frac{(T_2 - T_1)_{\text{actual}}}{(T_2 - T_1)_{\text{ideal}}} \quad (15.4.2)$$

In cases where significant acceleration occurs during the combustion process, total enthalpy or temperature must be used in Equations 15.4.1 and 15.4.2. Further, the ideal value of T_2 in Equation 15.4.2 or $(h_{sp})_{T_2}$ in Equation 15.4.1 is that corresponding to the calculated equilibrium flame temperature. Consequently, the consideration of dissociation effects is vital when temperatures are in excess of 1650°K.

In cases where the temperature is below 1650°K, combustion efficiency can be related to operating and fuel parameters as follows:

$$\eta_c = \frac{C_p (T_2 - T_1)_{\text{actual}}}{\left(\frac{f/a}{1 + f/a}\right) (\Delta h_c)_f} \quad (15.4.3)$$

where C_p is an average specific heat and $(\Delta h_c)_f$ is the fuel heat of combustion.

In practice, η_c can be determined by measuring the actual T_2 . This method, however, presents some difficulty in cases where combustion efficiencies are above 90%. The objective

of such testing usually involves reduction of the remaining combustion inefficiency and relatively small temperature measurement errors can cause large uncertainties in the determined inefficiency. Consequently, exhaust gas analysis has received wide acceptance as a means of more accurately determining combustion inefficiency. Exhaust concentrations of species containing chemical energy (predominantly carbon monoxide, unburned hydrocarbons, and hydrogen) must be determined. Inefficiency may then be calculated using the following equation.

$$1 - \eta_c = \frac{X_{CO}(\Delta h_c)_{CO} + X_{HC}(\Delta h_c)_{HC} + X_{H_2}(\Delta h_c)_{H_2}}{\frac{f/a}{1 + f/a} (\Delta h_c)_f} \quad (15.4.4)$$

where X_i is the mass fraction of species i , and $(\Delta h_c)_i$ is the heat of combustion of species i . The numerator of this expression represents the unused chemical energy per mass of exhaust while the denominator represents the chemical energy per mass of the initial fuel-air mixture.

Another common means of expressing Equation 15.4.4 involves the use of the emission index, EI, which represents the mass of CO, hydrocarbons, or H_2 in the exhaust per 1000 mass units of fuel. In this case the equation reduces to:

$$1 - \eta_c = 10^{-3} (.232 EI_{CO} + EI_{HC} + 2.76 EI_{H_2}) \quad (15.4.5)$$

Note that in cases where the combustion temperature exceeds 1650°K, Equation 15.4.4 and 15.4.5 must be modified to account for the amounts of CO, hydrocarbons, or H_2 which are present due to equilibrium dissociation. The calculated combustion inefficiency should correspond only to that CO, hydrocarbon, or H_2 which is present at concentrations levels in excess of equilibrium.

15.4.2 Flame Stabilization

Not all fuel-air mixtures are capable of supporting sustained combustion. The equivalence ratio, temperature, and pressure conditions within which combustion can be sustained in a quiescent, gas-phase system are defined as the flammability limits. Figure 15.4.1 illustrates the existence of both fuel lean and fuel rich limits for a kerosene-air system. While these limits are dependent on pressure, experimental configuration, and the existence of a quiescent system, the fundamental concept of flammability limits is invaluable as it defines the widest possible regimes of combustion. Flammability limit data for some typical hydrocarbons are indicated in Table 15.4.1. It is noted that variations in the limiting equivalence ratio are not substantial for the lean limit, that of primary practical importance to the combustor designer.

Flammability limits are sensitive to mixture temperature. Correlations have indicated the following approximate relationships between the mixture equivalence ratios for the lean and rich limits (ϕ_L and ϕ_R) and initial mixture temperature (Ref. 15.23):

$$\phi_L(T_2) - \phi_L(T_1) = -9.2 \times 10^{-4} (T_2 - T_1) \quad (15.4.6)$$

$$\phi_R(T_2) - \phi_R(T_1) = 25 \times 10^{-4} (T_2 - T_1) \quad (15.4.7)$$

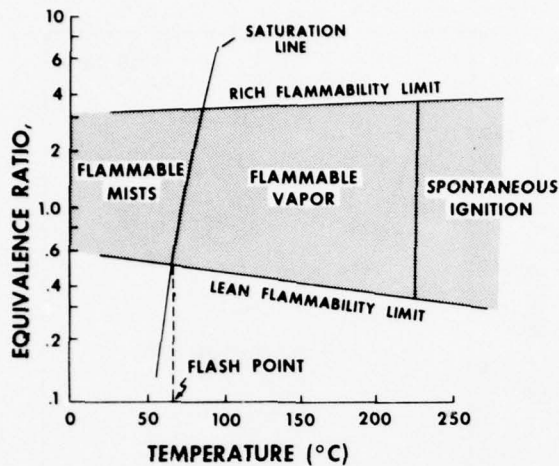

Figure 15.4.1: Flammability Characteristics for a Kerosene-Type Fuel in Air at Atmospheric Pressure.

TABLE 15.4.1: Flammability Limits in Air at Atmospheric Pressure and Room Temperature (From Ref. 15.23).

Fuel	Equivalence Ratio	
	Lean Limit	Rich Limit
n-Paraffins		
Methane	.53	1.56
Propane	.53	2.51
Butane	.60	2.88
Pentane	.58	3.23
Hexane	.55	3.68
Heptane	.63	3.78
Octane	.60	----
Isoparaffins		
2,2-Dimethylpropane	.54	2.01
2-Methylpentane	.55	3.42
2,2,4-Trimethylpentane	.66	----
2,2,3,3-Tetramethylpentane	.53	3.45
Olefins		
Ethene	.45	6.76
Propene	.52	2.47
1-Butene	.46	2.94
Aromatics		
Benzene	.50	2.75
Toluene	.61	----
Ethylbenzene	.50	----

Substantial pressure differences may also be observed if the test container is sufficiently small for wall quench reactions to be of importance.

Often a flowing system will not be capable of sustained stable combustion under temperature, pressure, and equivalence ratio conditions within the flammability limits. In practical systems, the

limits within which combustion will be stable are dependent on design details. An example of the onset of instability in a premixed fuel-air system is found in the stabilization process for a turbulent flame at the tip of a bunsen burner. The blow off characteristics of such a system have been successfully related to the velocity gradient near the bunsen burner rim.

To reduce the possibility of instabilities in flowing premixed systems, flameholders and primary zones are often used. In either case, the stability of the system is achieved by creating a region of violent recirculation and thorough mixing. Such a zone approximates the perfectly stirred reactor (PSR) which provides maximum stability for a flowing system. Fuel and air flow distributions are intended to provide a near-stoichiometric equivalence ratio in this region to maximize stability. In many cases, especially the flameholder, the portion of the flow intercepted by the recirculation zone is small and the predominant heat releasing combustion mechanism involves reactions within the shear layer which bounds the recirculation zone (see Figure 15.4.2). The PSR portion of the flow can be thought of as providing a continuous pilot to sustain the shear layer combustion region.

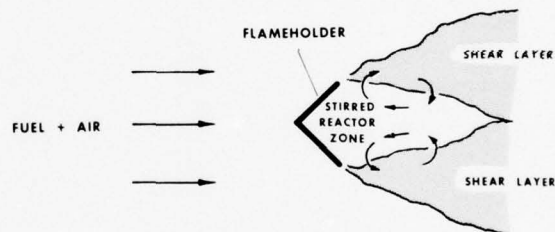

Figure 15.4.2 Physical Processes in Flameholding

Blow out of these systems can be envisioned as occurring in two phases (Refs. 15.24 and 15.25). First the less stable shear layer becomes unable to sustain itself as flow is increased and will extinguish. As previously implied, this results in the elimination of the predominant heat transfer source and causes the combustion efficiency to drop to nearly zero. The recirculation zone, being more stable, will continue to operate until $(m/VP^D)_{max}$ is reached (see Figures 15.3.4 and 15.3.5) at which time this region will also blow out. Since it represents a minor heat release factor, this final blow out point is of secondary interest.

15.4.3 Ignition

By definition, ignition is possibly only for those fuel-air mixture conditions within the flammability limits. The entire region within the flammability limits must be further

divided into two sub-regions separated by the spontaneous ignition temperature (SIT). This parameter is usually determined using a standardized test procedure where a liquid fuel is dropped into an open air container heated to a known temperature. The spontaneous ignition temperature is defined as the lowest temperature at which visible or audible evidence of combustion is observed. Typical values of SIT are listed in Table 15.4.2. Note the trend towards reduced SIT as the length of a n-paraffin chain is extended. Further the impact of side methyl groups in the case of iso-octane is to increase SIT to a level consistent with an n-paraffin of much lower molecular weight. Because these data are specific to a particular experiment, direct usage of these data as hazard criteria is not advisable. Most importantly from the combustor designer's standpoint, SIT variations due to pressure are significant. SIT decreases rapidly until approximately 2 atmospheres with apparently small changes above this pressure (15.20).

TABLE 15.4.2: Spontaneous Ignition Temperatures (From Reference 15.20).

Fuel	S.I.T. (°K)
Propane	767
Butane	678
Pentane	558
Hexane	534
Heptane	496
Octane	491
Nonane	479
Decane	481
Hexadecane	478
Iso-octane	691
Kerosene (JP-8 or Jet A)	501
JP-3	511
JP-4	515
JP-5	506

Above the spontaneous ignition temperature the key combustion characteristic is the ignition delay time. This parameter is defined as the time lag for a given fuel-air mixture to achieve significant reaction. Zero time may be defined as the incidence of initial mixing (as in a flow reactor) or of near instantaneous heating (as in a shock tube). While there are many ways to define the onset of significant reaction (dT/dt , $\Delta T/\Delta T_{max}$, etc.), the important point is that the ignition delay is exponentially related to initial temperature, T_1 :

$$t_{ign} \sim \exp(E_a/RT_1) \quad (15.4.8)$$

Because the ignition mechanism is not dependent on final flame temperature, t_{ign} is not strongly dependent on mixture ratio within the flammability limits. However, a strong dependence on pressure is usually observed. Ignition delay times for typical fuels are illustrated in Figure 15.4.3.

Below the spontaneous ignition temperature, an additional heat source must be utilized to allow temperatures to locally exceed the SIT. The most common method of achieving this is the spark discharge. The necessary amount of energy release to achieve ignition is called the minimum ignition energy (MIE). The quantity varies very

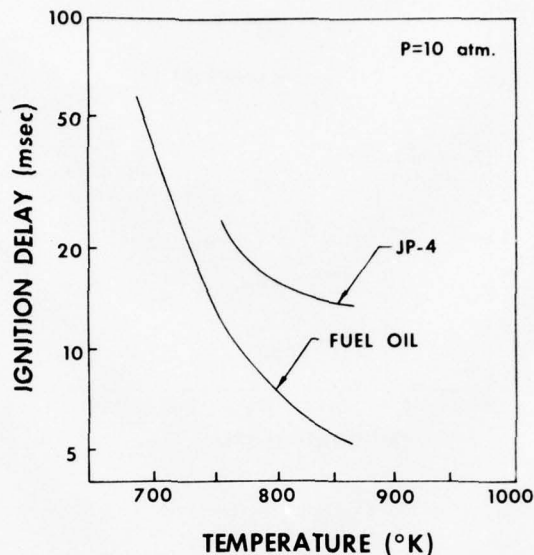

Figure 15.4.3 Ignition Delay Times for Practical Fuels.

significantly with equivalence ratio as shown in Figure 15.4.4 for the case of vapor fuel-air mixtures. It is important to note that the minimum condition is not always at a stoichiometric mixture ratio. For heavy fuels the minimum occurs closer to $\phi = 2$. Other important variables include initial mixture temperature and pressure. Finally, in the more practical case of liquid fuel spray-ignition, the extent of fuel vaporization is vital to ignition characteristics. Rao and Lefebvre (15.27) have shown that liquid fuel droplet diameter has a powerful influence on minimum ignition energy.

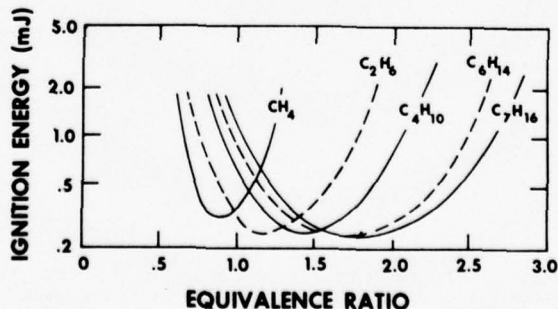

Figure 15.4.4 Minimum Ignition Energies

15.5 JET FUELS

15.5.1 Combustion Characteristics

The most fundamental of all fuel characteristics is the heat of combustion or heating value. This empirically-determined parameter represents the energy released per mass of fuel upon complete combustion when both initial and final temperatures are nearly 25°C. The actual experiment involves a combustion bomb pressurized with pure oxygen immersed in a well insulated water bath. The temperature rise of the water (usually only a few °C) is determined and the energy necessary to cause this increase for the entire system is determined. This value, which is calculated as negative for exothermic combustion reactions, is the constant volume higher heating value.

Since the experiment is performed at 25°C, condensed water from the combustion products within the bomb provides additional energy release which is included in the constant volume higher heating value. The measurement can be corrected to yield the constant volume lower heating value $(\Delta h_c)_v$ which corresponds to the energy which would have been released if the water in the combustion products had remained in the vapor phase. The constant pressure lower heating value $(\Delta h_c)_p$, which has been previously discussed in Section 15.2.1, can then be calculated:

$$\Delta h_c - (\Delta h_c)_v = (n_p - n_R) \frac{RT}{J} \quad (15.5.1)$$

where n_p and n_R are the number of moles of gaseous products and reactant, T is initial or final temperature (approximately 298°K), and J is the mechanical equivalent of heat. Values of Δh_c and heats of formation for typical hydrocarbons and jet fuels are shown in Table 15.5.1.

While heat of combustion differences among hydrocarbons are relatively small, changes in volatility are substantial. Fuels can range from methane (boiling point of -161°C) to heavy liquid hydrocarbons containing naphthalene (boiling point of 211°C). In non-aircraft turbine applications, future fuel candidates include even residual oils (which have non-volatile components). Common aircraft turbine fuels, however, are a blend of many hydrocarbons and their volatility is usually characterized by a distillation curve as shown in Figure 15.5.1.

The chemical composition of common jet fuels is extremely complex. The hundreds of hydrocarbon types present are often categorized into three groups, paraffins, olefins, and aromatics. Paraffins are the straight chain or cyclic saturated molecules like propane, butane, or cyclohexane. These are generally very clean burning fuels (low soot formation). Olefins are characterized by the presence of a carbon-carbon double bond as occurs in ethylene. These compounds are suspected of causing gum and stability problems in jet fuels. Aromatics are molecules containing unsaturated ring structures. These may be single ring (e.g. benzene) or polycyclic (e.g. naphthalene) in nature. The combustion of aromatic fuels is likely to cause problems associated with carbon particle formation, flame radiation and exhaust smoke.

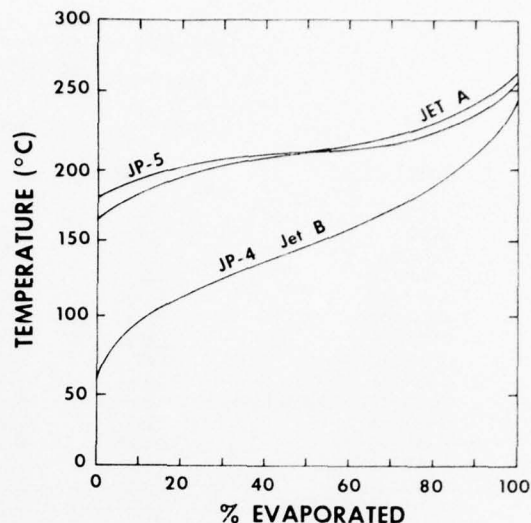

Figure 15.5.1 Distillation Characteristics of Common Jet Fuels.

A final important fuel characteristic from the handling, crash hazard, and tactical vulnerability standpoints is the flash point. This parameter is empirically determined using a controlled temperature container partially filled with fuel. A small flame is passed over the fuel/air mixture. The minimum temperature at which some evidence of ignition is observed is defined as the flash point. It has been demonstrated that this temperature corresponds to conditions where the equilibrium vapor/air mixture above the liquid fuel is at the lean flammability limit. This characteristic is illustrated in Figure 15.4.1.

15.5.2 Common Jet Fuels

Three jet fuel types are in wide use throughout the free world. JP-4 is the fuel used by the air forces of NATO, including the United States. Jet B, a fuel nearly identical to JP-4, is used by Canadian commercial airlines. These fuels can be grossly represented as a blend of kerosene and gasoline. The high volatility of JP-4 results in a vapor pressure of about 0.17 atm (2.5 psia) at 310°K (100°F), and a flash point of approximately -25°C.

Jet A is the kerosene-based fuel used by most of the world's commercial airlines, including the United States. It has a much lower volatility than JP-4 resulting in a flash point of about 52°C. Because of the reduced probability of post crash fires and the reduction of combat vulnerability, the NATO nation air forces are considering conversion to JP-8. This fuel is nearly identical to Jet A-1, a commercial fuel similar to Jet A in all respects except freeze point (-50°C versus -40°C for Jet A). The combustion characteristics of JP-8, Jet A, and Jet A-1 are virtually identical.

The unique problems associated with shipboard jet fuel use cause the U.S. Navy to use a third fuel type, JP-5, which has an even higher flash point (>63°C).

TABLE 15.5.1: Heats of Combustion and Formation
(From Reference 15.1)

Name	Formula	Mole- cular Weight	$-\Delta h_c$ Constant Pressure Lower Heating Value (cal/gm)	Δh_f Heat of Formation (cal/gm)
Methane	CH ₄	16.04	11,946	1115
Ethane	C ₂ H ₆	30.07	11,342	739
Propane	C ₃ H ₈	44.09	11,072	563
n-Butane	C ₄ H ₁₀	58.12	10,925	513
Isobutane	C ₄ H ₁₀	58.12	10,897	541
n-Pentane	C ₅ H ₁₂	72.15	10,744	573
n-Hexane	C ₆ H ₁₄	86.17	10,685	551
n-Heptane	C ₇ H ₁₆	100.20	10,643	535
n-Octane	C ₈ H ₁₈	114.22	10,611	523
2,2,4-Trimethylpentane	C ₈ H ₁₈	114.22	10,592	542
n-Nonane	C ₉ H ₂₀	128.25	10,587	
n-Decane	C ₁₀ H ₂₂	142.28	10,567	
n-Tetradecane	C ₁₄ H ₃₀	198.38	10,515	
n-Hexadecane	C ₁₆ H ₃₄	226.43	10,499	
n-Pentatriacontane	C ₃₅ H ₇₂	492.93	10,573	
Ethylene	C ₂ H ₄	28.05	11,264	-445
Propylene	C ₃ H ₆	42.08	10,935	-116
Isobutene	C ₄ H ₈	56.10	10,759	60
Octene	C ₈ H ₁₆	112.21	10,556	
Cyclopentane	C ₅ H ₁₀	70.13	10,458	
Cyclohexane	C ₆ H ₁₂	84.16	10,376	
Benzene	C ₆ H ₆	78.11	9,588	-150
Toluene	C ₇ H ₈	92.13	9,680	-31
α -Xylene	C ₈ H ₁₀	106.16	9,748	-55
Methyl alcohol	CH ₃ OH	32.0	4,802	
Ethyl alcohol	C ₂ H ₅ OH	46.0	6,447	
Propyl alcohol	C ₃ H ₇ OH	60.0	7,388	
Butyl alcohol	C ₄ H ₉ OH	74.1	7,936	
Acetylene	C ₂ H ₂	26.04	11,518	-2,080
Hydrogen	H ₂	2.016	28,651	0
Carbon (solid, graphite)	C	12.01	7,826	0
Carbon (coke) to CO ₂	C	12.01	8,077	0
Carbon (coke) to CO	C	12.01	2,467	0
Carbon Monoxide	CO	28.01	2,413	
JP-4	CH _{2.02}		10,389	476
JP-5	CH _{1.92}		10,277	458
JP-8/Jet A/Jet A-1	CH _{1.94}		10,333	428

The physical and chemical properties of these fuels are illustrated in Table 15.5.2. Yearly consumption figures for 1974 have also been shown.

15.6 SUMMARY

This chapter has reviewed fundamental concepts necessary for the understanding of aero-propulsion combustion. Two additional chapters will consider the practical application of this information to mainburners (Chapter 20) and afterburners (Chapter 21). Much of this chapter has reflected the theme that the subject of combustion involves interdisciplinary study of chemistry, thermodynamics, and gas dynamics.

Key topics to the study of combustion chemistry are reaction rates, equilibrium considerations, and the mechanisms of hydrocarbon-air combustion. The Arrhenius relationship, which describes the basic dependencies of reaction rate on pressure, temperature, and concentration, has been highlighted and its impact on combustion systems has been described. CO₂ and H₂O dissociation

and the water gas relationship are the primary equilibrium considerations. Current understanding of hydrocarbon combustion has been reviewed. This complex process can be envisioned as a sequence of events involving hydrocarbon pyrolysis and partial oxidation to H₂ and CO, chain branching reaction resulting in H₂ consumption, and CO oxidation by OH radicals generated during chain branching.

Combustion thermodynamics involves relating energy release from fuel consumption to combustion product effects. For constant pressure systems, the first law of thermodynamics implies conservation of total enthalpy across the reacting system. Using this relationship, definitions and methods of calculating flame temperature have been offered. Theoretical flame temperature, calculated assuming no dissociation, has been used to explain the effects of initial temperature, fuel-air ratio, fuel type, and extent of vitiation. Methods of more accurate flame temperature calculation, including dissociation effects, have been presented and the above-described effects were illustrated.

TABLE 15.5.2: Important Jet Fuel Properties

Property	JP-4		JP-8 (Jet A-1)		JP-5	
	Spec Req'm't	Typical Value	Spec Req'm't	Typical Value	Spec Req'm't	Typical Value
Vapor Pressure (atm) @ 38°C (100°F)	.13 - .2	.18	--	.007	--	.003
Initial Boiling Point (°C)	--	60.	--	169.	--	182.
End Point (°C)	--	246	288	265	288	260
Flash Point (°C)	--	-25	>49	52	>63	65
Aromatic Content (% Vol)	<25	12	<20	16	<25	16
Olefinic Content (% Vol)	< 5	1	--	1	--	1
Saturates Content (% Vol)	--	87	--	83	--	83
Net Heat of Combustion (cal/gm)	>10,222	10,388	>10,222	10,333	>10,166	10,277
Specific Gravity	0.751 - 0.802	.758	0.755 - 0.830	0.810	0.788 - 0.845	0.818
U.S. Yearly Consumption (10 ⁹ gal)		5		12		1

Gas dynamics and diffusion processes affecting combustion have been described. Premixed laminar flames have been discussed and the dependence of propagation rate on temperature and especially fuel-air ratio have been highlighted. In the case where fuel and air are not initially mixed, rates of fuel and oxygen diffusion into the flame region control the burning rate. Key properties of diffusion flames and methods of analyzing laminar systems have been reviewed. The impact of turbulence on premixed and diffusion flames has been discussed. In the case of premixed systems, flame propagation rates are enhanced. In the case of diffusion flames, combustion zone mixing rates are increased, resulting in greater burning rates. Finally a model of the ultimate turbulent system, the perfectly stirred reactor, has been offered. In this system, mixing rates are instantaneous relative to chemical kinetic effects and uniform temperature and species concentration exist throughout the reactor. This perfectly stirred reactor analysis has indicated important dependencies of such a system on temperature, mixture ratio, and combustion kinetics.

Combustion parameters of importance to aero-propulsion have been reviewed and explained using the fundamental information regarding chemistry, thermodynamics, and gas dynamics presented in earlier sections. Parameters which have been reviewed are combustion efficiency, flame stabilization, and ignition. Combustion efficiency has been defined and related to both exhaust temperature and species concentration. Flame stabilization has been discussed relative to the definition of flammability (which applies to a quiescent system), as well as to the basic processes occurring in flameholder or primary zone regions. In the latter case, the roles of the recirculation and shear layer zones have been highlighted. Ignition has been discussed in terms of spontaneous ignition temperature, ignition delay time, and minimum ignition energy.

Finally, the important combustion characteristics of jet fuels have been defined and discussed. These include the heats of combustion and formation, volatility and distillation characteristics, and

flash point. The properties of current jet fuels, JP-4 (or Jet B), JP-8 (similar to Jet A), and JP-5, have been tabulated.

15.7 BIBLIOGRAPHY AND REFERENCES

15.7.1 Bibliography

- American Chemical Society, Literature of the Combustion of Petroleum, No. 20 of the Advances in Chemistry Series, American Chemical Society, Washington, DC, 1958.
- Combustion Institute, Proceedings of the International Combustion Symposia, Vols. 1-15, The Combustion Institute, Pittsburgh, PA.
- Fenimore, C. P., Chemistry in Premixed Flames, Pergamon Press, New York, 1964.
- Frank Kaminetskii, D. A., Diffusion and Heat Exchange in Chemical Kinetics, translated by N. Thon, Princeton University Press, Princeton.
- Fristrom, R. M., and Westenberg, A. A., Flame Structure, McGraw-Hill Book Company, New York, 1965.
- Gaydon, A. G., and Wolfhard, H. G., Flames, Chapman and Hall, London, 1960.
- Laidler, K. J., Reaction Kinetics, Vol. I, Homogeneous Gas Reactions, Pergamon Press, New York, 1963.
- Laidler, K. J., Chemical Kinetics, Second Edition, McGraw Hill Book Co., New York, 1961.
- Lewis, B., and Von Elbe, G., Combustion Flames and Explosions of Gases, Academic Press, New York, 1964.
- Moelwyn-Hughes, E. A., Physical Chemistry, Second Revised Edition, MacMillan, New York, 1964.

Moore, W. J., Physical Chemistry, Third Edition, Prentice-Hall Inc., Englewood Cliffs, NJ, 1962.

Propulsion Chemistry Division, Lewis Flight Propulsion Laboratory, "Basic Considerations in the Combustion of Hydrocarbon Fuels with Air," edited by H. C. Barnett and R. R. Hibbard, NACA Report 1300, 1957.

Smith, M. L., and Stinson, K. W., Fuels and Combustion, McGraw Hill Book Company Inc., 1952.

Strehlow, R. A., Fundamentals of Combustion, International Textbook Co., Scranton, PA, 1967.

Swithenbank, J., Combustion Fundamentals, Air Force Office of Scientific Research, Washington, DC, February 1970.

Williams, F. A., Combustion Theory, Addison-Wesley, Reading, MA, 1965.

15.7.2 Cited References

15.1. Smith, M. L., and Stinson, K. W., Fuels and Combustion, McGraw Hill Book Co., Inc., 1952.

15.2. Edelman, R. B., Fortune, O., and Weilerstein, G., "Some Observations on Flows Described by Coupled Mixing and Kinetics," Emissions from Continuous Combustion Systems, edited by W. Cornelius and W. Agnew, Plenum Press, New York, 1972, pp 55-90.

15.3. Howard, J. B., Williams, G. C., and Fine, D. H., "Kinetics of Carbon Monoxide Oxidation in Postflame Gases," 14th International Symposium on Combustion, the Combustion Institute, Pittsburgh, PA, 1973, pp 975-986.

15.4. Mosier, S. A., and Roberts, R., "Low Power Turbopropulsion Combustor Exhaust Emissions," AFAPL-TR-73-36, Vols. 1-3, Air Force Aero Propulsion Laboratory, Wright-Patterson AFB, OH, 1974.

15.5. Fremont, H. A., Powell, H. N., Shaffer, A., and Siecia, S. N., Properties of Combustion Gases, Vols. I and II, Aircraft Gas Turbine Development Department, General Electric Co., Cincinnati, OH, 1955.

15.6. Gordon, S., and McBride, B. J., "Computer Program for Calculation of Complex Chemical Equilibrium Compositions, Rocket Performance, Incident and Reflected Shocks, and Chapman Jouguet Detonations," NASA Special Publication 273, 1971.

15.7. Zabetakis, M. G., "Flammability Characteristics of Combustible Gases and Vapors," Bureau of Mines Bulletin 627, U.S. Dept. of Interior, 1965.

15.8. Belles, Frank E., "Flame Propagation in Premixed Gases," in Literature of the Combustion of Petroleum, No. 20 of the Advances in Chemistry Series, American Chemical Society, Washington, DC, pp 166-186, 1958.

15.9. Burke, S. P., and Schumann, T. E. W., "Diffusion Flames," Ind. Eng. Chem., Vol. 20, 1928, pp 998-1004.

15.10. Dryer, F. L., "Fundamental Concepts on the Use of Emulsified Fuels," presented at the Fall Meeting of the Western States Section of the Combustion Institute, Palo Alto, California, 1975.

15.11. Brokaw, R. S., and Gerstein, M., "Diffusion Flames" Chapter VII of Basic Considerations in the Combustion of Hydrocarbon Fuels with Air, NACA Report 1300, 1957.

15.12. Rao, K. V. L., and Lefebvre, A. H., "Evaporation Characteristics of Kerosene Sprays Injected into a Flowing Air Stream," Combustion and Flame, Vol. 26, No. 3, June 1976, pp 303-310.

15.13. Lefebvre, A. H., and Reid, R., "The Influence of Turbulence on the Structure and Propagation of Enclosed Flames," Combustion and Flame, Vol. 10, pp 355-366.

15.14. Damkohler, G., Z. Elektrochem, 46, 1949, p 601.

15.15. Shchelkin, K. I., Soviet Phys-Tech Phys., 13, Nos. 9-10, 1943.

15.16. Karlovitz, B., Denniston, D. W., and Wells, F. E., J. Chem Phys., Vol. 19, 1951, p 541.

15.17. Scurlock, A. C., and Grover, J. J., Fourth Symposium (International) on Combustion, The Combustion Institute, Pittsburgh, PA, 1953, p 645.

15.18. Gerstein, J. and Dugger, G. L., "Turbulent Flames," Chapter V of Basic Considerations in the Combustion of Hydrocarbon Fuels with Air, NACA Report 1300, 1957.

15.19. Mellor, A. M., "Gas Turbine Engine Pollution," in Pollution Formation and Destruction in Flames, Vol. 1 of Progress in Combustion Science and Energy, N. A. Chigier Editor, 1975.

15.20. Gouldin, F. C., "Controlling Emissions from Gas Turbines - The Importance of Chemical Kinetics and Turbulent Mixing," Combustion Science and Technology, Vol. 7, 1973.

15.21. Woodward, E. C., "Application of Chemical Reactor Theory to Combustion Processes," in Literature of the Combustion of Petroleum, No. 20 of the American Chemical Society Advances in Chemistry Series, 1958, pp 22-38.

15.22. Longwell, J. P., Frost, E. E., and Weiss, M. A., "Flame Stability in Bluff Body Recirculation Zones," Industrial and Engineering Chemistry, Vol. 45, 1953, pp 1629-1633.

15.23. Dynamic Science Corp., "Fire Protection Research Program for Supersonic Transport," Report No. APL-TDR-64-105, AF Aero Propulsion Laboratory, Wright-Patterson AFB, OH, 1964.

15.24. Zukoski, E. E., and Marble, F. E., Proceedings Gas Dynamics Symposium on Aerothermochemistry, p 205, Northwestern University, 1956.

15.25. Altenkirch, R. A., and Mellor, A. M., "Emissions and Performance of Continuous Flow Combustors," Fifteenth International Symposium on Combustion, the Combustion Institute, Pittsburgh, PA., 1974, pp 1181-1189.

15.26. Spadaccini, L. J., "Autoignition Characteristics of Hydrocarbon Fuels at Elevated Temperatures and Pressures," ASME Paper 76-GT-3, 1976.

15.27. Rao, K. V. L., and Lefebvre, A. H., "Minimum Ignition Energies in Flowing Kerosene-Air Mixtures," Combustion and Flame, Vol 27, No. 1, August 1976, pp. 1-20.

15.28. Lewis, B., and Von Elbe, G., Combustion Flames and Explosions of Gases, Academic Press, New York, 1961.

15.29. Exxon Company, USA, Data Book for Designers: Fuels, Lubricants, and Hydraulic Fluids used In Aerospace Applications, Houston, TX, 1973.

PART II

TURBOPROPULSION COMBUSTION TECHNOLOGY

Chapter 20 of a Comprehensive Study of Aircraft Gas

Turbine Engines, edited by G. C. Oates

by:

Robert T. Henderson
AF Aero Propulsion Laboratory
AF Wright Aeronautical Laboratories
Wright-Patterson AFB, Ohio 45433

and

William S. Blazowski*
AF Aero Propulsion Laboratory
AF Wright Aeronautical Laboratories
Wright-Patterson AFB, Ohio 45433

* Currently at Exxon Research and Engineering Company, Linden, New Jersey.

TABLE OF CONTENTS

CHAPTER 20 TURBOPROPULSION COMBUSTION

	<u>Page</u>		
20.0 INTRODUCTION	20-1	20.4.1.2 Exhaust Content	20-15
20.1 COMBUSTION SYSTEM DESCRIPTION/DEFINITIONS	20-1	20.4.1.3 Emission Characteristics	20-17
20.1.1 Types	20-1	20.4.1.4 Minimization of Emissions	20-19
20.1.2 Size	20-2	20.4.2 Future Jet Fuels	20-21
20.1.3 Combustor Configurations	20-3	20.4.2.1 Fuel Effects on Combustion Systems	20-21
20.1.4 Flowpath Terminology	20-3	20.4.2.2 Combustion System Design Impact	20-23
20.2 COMPONENT CONSIDERATIONS	20-3	20.4.3 Design and Performance Advancements	20-23
20.2.1 Combustion System Demands	20-3	20.4.3.1 High Mach Combustor (HMC)	20-23
20.2.1.1 Combustion Efficiency	20-4	20.4.3.2 Advanced Diffusion Techniques	20-24
20.2.1.2 Overall Pressure Loss	20-4	20.4.3.3 Shingle Liner	20-24
20.2.1.3 Exit Temperature Profile	20-5	20.5 CONCLUSIONS	20-24
20.2.1.4 Combustion Stability	20-6	20.6 REFERENCES	20-26
20.2.1.5 Ignition	20-6		
20.2.1.6 Size/Weight/Cost	20-6		
20.2.1.7 Durability/Reliability/Maintainability	20-7		
20.2.1.8 Exhaust Emissions	20-7		
20.2.2 Design Factors	20-7		
20.2.2.1 Inlet Diffuser	20-8		
20.2.2.2 Dome and Snout	20-9		
20.2.2.3 Liner	20-9		
20.2.2.4 Fuel Injection	20-10		
20.2.2.5 Ignition	20-12		
20.2.2.6 Materials	20-12		
20.3 DESIGN TOOLS	20-13		
20.3.1 Combustor Modeling	20-13		
20.3.1.1 Empirical	20-13		
20.3.1.2 Combined Empirical/Theoretical	20-14		
20.3.1.3 Theoretical	20-14		
20.3.2 Combustion Diagnostics	20-14		
20.4 FUTURE REQUIREMENTS	20-15		
20.4.1 Exhaust Emissions	20-15		
20.4.1.1 Problem Definition	20-15		

LIST OF ILLUSTRATIONS

CHAPTER 20 TURBOPROPULSION COMBUSTION

	<u>Page</u>
20.1.1 Combustor Types	20-1
20.1.2 T63 Turboprop Engine with Can Combustor	20-1
20.1.3 J33 Turbojet Engine with Can Combustors	20-2
20.1.4 J79 Cannular Combustor	20-2
20.1.5 TF39 Annular Combustor	20-2
20.1.6 WR19 Turbofan Engine	20-2
20.1.7 JT9D Annular Combustor	20-2
20.1.8 TFE 731 Turbofan Engine With Reverse-Flow Combustor	20-3
20.1.9 Main Combustor Airflow Distribution	20-3
20.2.1 Pressure Loss Correlation	20-5
20.2.2 Radial Temperature Profile at Combustor Exit	20-6
20.2.3 Combustion Stability Characteristics	20-6
20.2.4 Ignition/Relight Envelope	20-6
20.2.5 Component Identification	20-7
20.2.6 Diffuser Design and Performance Characteristics	20-8
20.2.7 Contemporary Diffuser Designs	20-9
20.2.8 Combustor Dome Types	20-9
20.2.9 Combustor Cooling Techniques	20-10
20.2.10 Liner Cooling Characteristics	20-11
20.2.11 Fuel Injection Methods	20-11
20.2.12 Pressure Atomizing Fuel Injector	20-11
20.2.13 Spark Ignitor	20-12
20.3.1 Empirical Combustion Efficiency Correlation	20-13
20.3.2 Prediction of Combustion Efficiency Using θ -Parameter	20-14
20.3.3 Effect of Primary Zone \dot{Q} on Inlet Temperature Factor	20-14
20.3.4 Combustor Model Computational Schematic	20-14
20.4.1 CO and HC Idle Emissions	20-17
20.4.2 Correlation of Current Engine NO _x Emissions with Combustor Inlet Temperature	20-18
20.4.3 Dependence of Sea Level Standard Day NO _x Emissions on Compressor Pressure Ratio of Current Engines	20-18

20.4.4 Dependence of NO _x Emission on Flight Mach Number	20-19
20.4.5 Staged Premix Combustor, JT9D Engine	20-19
20.4.6 Ideal Effectiveness of Water Injection for NO _x Control	20-20
20.4.7 Effect of Residence Time and ϕ on Nitrogen Oxide Emissions	20-20
20.4.8 Overall Scheme for Alternate Jet Fuel Development Program	20-21
20.4.9 Liner Temperature Correlation for Many Combustor Types	20-22
20.4.10 Smoke Emission Dependence on Hydrogen Content	20-22
20.4.11 Fuel Bound Nitrogen Conversion to NO _x in an Aircraft Gas Turbine Combustor	20-23
20.4.12 Effect of Lean Operation on Combustor Fuel Sensitivity	20-23
20.4.13 HMC With Advanced Bleed Diffuser	20-23
20.4.14 Swirl Burning HMC	20-24
20.4.15 Vortex Controlled Diffuser	20-24
20.4.16 Shingle Liner Combustor	20-24
20.5.1 Annular Combustor Development Trends	20-25
20.5.2 F101 Annular Combustor	20-25
20.5.3 Catalytic Combustor Efficiency	20-25

LIST OF TABLES

CHAPTER 20 TURBOPROPULSION COMBUSTION

	<u>Page</u>
20.2.1 Contemporary Combustor Size, Weight and Cost	20-7
20.4.1 Engine Combustion Products	20-16

20.0 INTRODUCTION

The evolution of aircraft gas turbine combustor technology over the past forty years has been extremely impressive. While the combustion system was the primary limitation in development of the first aircraft gas turbine in 1939 (Ref 20.1), the complexity and hardware costs associated with current rotating engine components (compressor and turbine) now far exceed that of the combustion system. Recent developments, however, have once again caused significant shifts in development emphasis toward combustion technology. New concepts and technology improvements will be necessary to satisfy recently legislated exhaust pollutant regulations. Moreover, future emphasis on engines which can utilize fuels with a broader range of characteristics are expected to require additional combustor technology development.

Beyond these externally imposed requirements are the combustion system performance improvements necessary to keep pace with new engine developments. Further reductions in combustor physical size and weight are expected to continue as firm requirements. Performance improvements, especially with respect to engine thrust/weight ratio and specific fuel consumption, will require higher combustor temperature rise, greater average turbine inlet temperatures, and closer adherence to the design temperature profile at the turbine inlet. High performance designs must also permit greater Mach number operation within and around the combustor to reduce pressure drop and minimize the physical size of compressor exit diffuser hardware. Costs (both initial and operating) must be minimized, as recent experiences with high temperature engines have confirmed the necessity to consider reliability and maintenance aspects of life cycle cost as well as performance and fuel consumption.

The purpose of this chapter is to introduce the reader to the hardware aspects of aircraft gas turbine main burners; fundamental aspects have been addressed in Chapter 15, and afterburners are to be discussed in Chapter 21. A number of reference texts (Ref 20.2 - 20.6) have been published which address various aspects of turbopropulsion combustion in a detailed manner. In particular, reference 20.6 cites more than 700 reports and technical articles on the topic of turbopropulsion combustion. The balance of this chapter will discuss the following four topics: a) description of various hardware types and definition of all terms of importance, b) review of parameters pertinent to performance, c) discussion of tools available to the combustor designer, and d) review of the future requirements of exhaust emission reduction, achievement of greater fuel flexibility, and advancement of burner performance.

20.1 COMBUSTION SYSTEM DESCRIPTION/DEFINITIONS

In order to fully appreciate and comprehend contemporary turbopropulsion combustor design philosophy, a number of general design and performance terms must be understood. The purpose of this section is to acquaint the reader with commonly used combustion nomenclature which will be utilized throughout this chapter. A brief description and/or definition of combustion system types, sizes, configurations, and flow-path terminology is given in

the following subsections.

20.1.1 Types

Turbine engine combustors have undergone continuing development over the past 40 years resulting in the evolution of a variety of basic combustor configurations. Contemporary combustion systems may be broadly classified into one of the three types schematically illustrated in Figure 20.1.1.

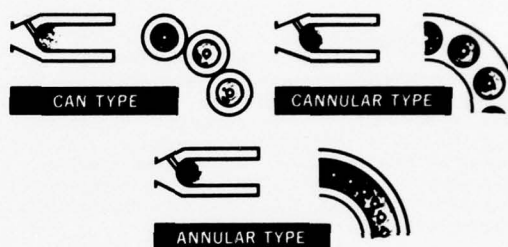

Figure 20.1.1 Combustor Types

a. Can: A can combustion system consists of one or more cylindrical combustors each contained in a combustor case. In the small T-63 turboshaft engine of Figure 20.1.2, a single combustor can is used while larger propulsion systems use a multicann assembly in an arrangement designed to provide a continuous annular gas flow to the turbine section. The combustion system of the J33 engine illustrated in Figure 20.1.3 is representative of such multicann systems.

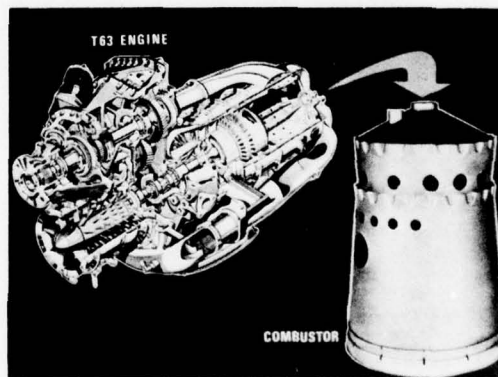

Figure 20.1.2 T63 Turboprop Engine With Can Combustor

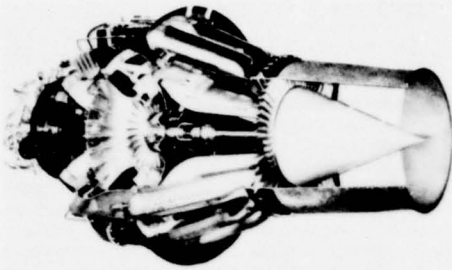

Figure 20.1.3 J33 Turbojet Engine With Can Combustors

b. Cannular: This combustion system consists of a series of cylindrical-combustors arranged within a common annulus--hence, the cannular name. This combustor type is the most common in the current aircraft turbine engine population, but is rapidly being replaced with the annular type as more modern engines comprise larger portions of the fleet. The J79 turbojet engine main combustor, illustrated in Figure 20.1.4, exemplifies cannular systems.

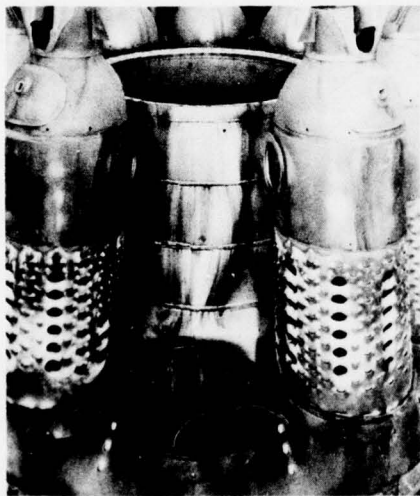

Figure 20.1.4 J79 Cannular Combustor

c. Annular: Most modern combustion systems employ the annular design wherein a single combustor having an annular cross-section supplies gas to the turbine. An example of this combustor type, the TF39, is illustrated in Figure 20.1.5. The improved combustion zone uniformity, design simplicity, reduced liner surface area, and shorter system length provided by the common combustion annulus has made the annular combustor the leading contender for all future propulsion systems.

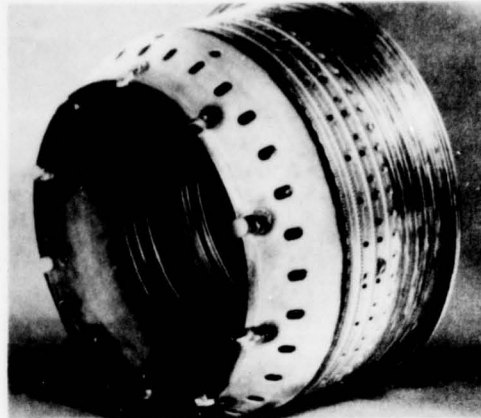

Figure 20.1.5 TF39 Annular Combustor

20.1.2 Size

Contemporary combustion systems may come in a variety of sizes ranging from the small 2.3 Kg/sec (5 lbm/sec) annular burner of the WR-19 engine (Figure 20.1.6) to the large 110 Kg/sec (242 lbm/sec) annular combustor of the JT9D engine (Figure 20.1.7). The WR-19 combustor is approximately 25.4 cm (10 in) in diameter and intended principally for missile and remotely-piloted vehicle engine application while the JT9D combustor is approximately 91 cm (36 in) in diameter and is used in engines to power the wide-body 747 and DC-10 class aircraft.

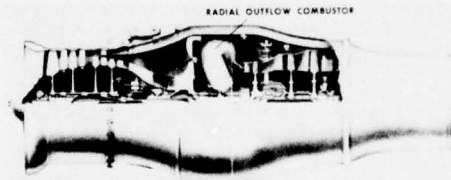

Figure 20.1.6 WR19 Turbofan Engine

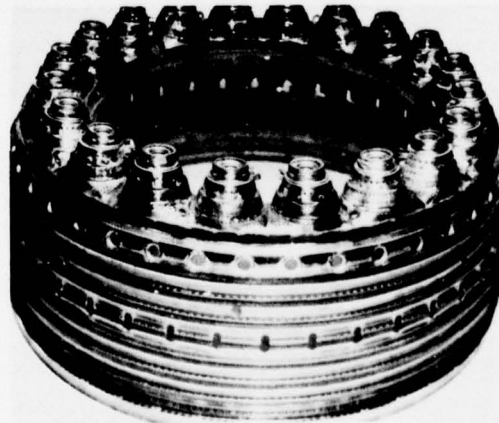

Figure 20.1.7 JT9D Annular Combustor

20.1.3 Combustor Configurations

Combustion system configuration may also be classified according to airflow direction through the chamber.

a. Axial Thru-Flow: The most common configuration is the axial thru-flow design where combustion air flows in a direction approximately parallel to the axis of the engine. The JT9D annular burner illustrated in Figure 20.1.7 is typical of an axial thru-flow configuration.

b. Reverse-Flow, Folded: Engines with centrifugal compressors often employ compact, reverse flow combustors. In these combustion systems, air is passed along the outside of the burner and then turned to flow through the combustion chamber. The combustion gases are then turned once again to pass through the turbine. Hence, the air is required to make two 180° reversals in moving from the compressor to the turbine. The reverse flow configuration is often employed to minimize engine length, especially in small turboshaft and turbofan engines where propulsion system length is an important design factor. Figure 20.1.8 illustrates the TFE-731 combustor, a typical reverse flow configuration.

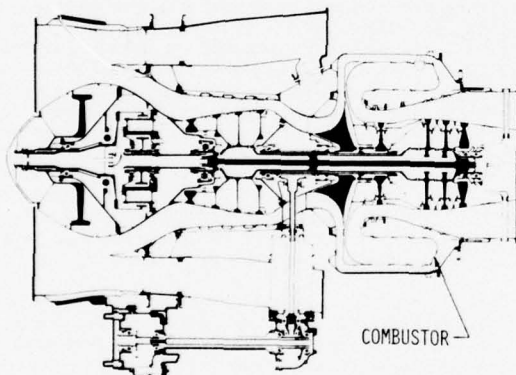

Figure 20.1.8 TFE 731 Turbofan Engine with Reverse-Flow Combustor

c. Radial-Inflow or Radial-Outflow: The radial-inflow and radial-outflow combustor configurations are also well suited to centrifugal compressor propulsion systems. The radial-inflow combustor has an outward-oriented dome or headplate with combustion gas flow directed toward the engine centerline, while the radial-outflow configuration has an inward-oriented dome with the primary flow direction being away from the engine centerline. For example, the WR-19 combustor illustrated in Figure 20.1.6 is typical of compact radial-outflow designs.

20.1.4 Flowpath Terminology

This subsection will identify and briefly describe basic airflow distribution terminology for a conventional combustor. Distribution of air in, around, and through the combustor results in the four basic airflow regions illustrated in Figure 20.1.9. Effective control of this air distribution is vital to the attainment of complete combustion, stable operation, correct combustor exit temperature profile, and acceptable liner temper-

atures for long life.

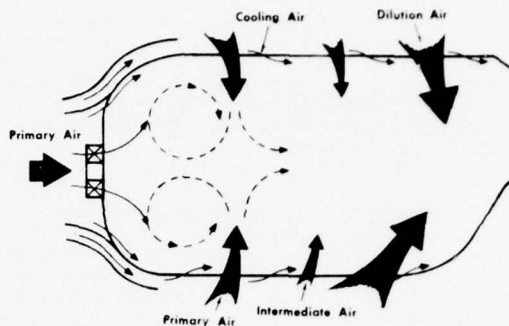

Figure 20.1.9 Main Combustor Airflow Distribution

a. Primary Air: This is the combustion air introduced through the dome or headplate of the combustor and through the first row of liner air holes. This air mixes with incoming fuel producing the approximately stoichiometric mixture necessary for optimum flame stabilization and operation (see discussion on combustion stabilization in Section 15.4 of Chapter 15).

b. Intermediate Air: To complete the reaction process and consume the high levels of primary zone CO, H₂, and unburned fuel, intermediate air is introduced through a second row of liner holes. The reduced temperature and excess air cause CO and H₂ concentrations to decrease (see the chemical kinetic and equilibrium relationships presented in Section 15.1 of Chapter 15).

c. Dilution Air: In contemporary systems, a large quantity of dilution air is introduced at the rear of the combustor to cool the high temperature gases to levels consistent with turbine design limitations. The air is carefully used to tailor exit temperature radial profile to ensure acceptable turbine durability and performance. This requires minimum temperatures at the turbine root (where stresses are highest) and at the turbine tip (to protect seal materials). However, modern and future combustor exit temperature requirements are necessitating increased combustion air in the primary and intermediate zones; thus, dilution zone air flow is necessarily reduced or eliminated to permit these increases.

d. Cooling Air: Cooling air must be used to protect the combustor liner and dome from the high radiative and convective heat loads produced within the combustor. This air is normally introduced through the liner such that a protective blanket or film of air is formed between the combustion gases and the liner hardware. Consequently, this airflow should not directly affect the combustion process. A detailed discussion of the various design techniques employed to cool the combustor liner is given in 20.2.2.3.

20.2 COMPONENT CONSIDERATIONS

20.2.1 Combustion System Demands

During the past several years, significant engine performance gains have required advancements in turbopropulsion combustion. Advanced strategic

and tactical aircraft propulsion systems utilize main burners with the operational flexibility to accept broad variations in compressor discharge pressure, temperature and airflow while providing an acceptable exit temperature profile with minimum pressure loss and near-perfect combustion efficiency. Furthermore, heat release rates and combustor temperature rise capabilities have significantly increased and will continue to progress toward stoichiometric exit temperature conditions.

A broad list of combustion system performance and design objectives is required of all new combustors as they enter development. Although this list can be quite lengthy, the more important requirements, some of which were alluded to above, are given below:

Performance Objectives

- . High combustion efficiency (100%) at all operating conditions.
- . Low overall system total pressure loss.
- . Stable combustion at all operating conditions.
- . Reliable ground-level ignition and altitude relight capability.

Design Objectives

- . Minimum size, weight, and cost.
- . Combustor exit temperature profile consistent with turbine design requirements.
- . Low stressed structures.
- . Effective hot parts cooling for long life.
- . Good maintainability and reliability.
- . Minimum exhaust emissions consistent with current specified limitations and regulations.

A number of these demands will be discussed in more detail in the following subsections.

20.2.1.1 Combustion Efficiency: In that propulsion system fuel consumption has a direct effect on aircraft system range, payload and operating cost, it is imperative that design point combustor efficiency be as close to 100% as possible. Combustion efficiency at the high power/high fuel consumption conditions of take-off and cruise is always near 100% (usually greater than 99.5%). However, off-design efficiency, particularly at idle, can be in the low nineties. With the advent of chemical emission controls and limitations, this parameter becomes of particular significance during low power operation. For example, combustion efficiencies at off-design conditions, such as idle, must now exceed 98.5% to satisfy limitations on exhaust carbon monoxide and unburned hydrocarbons.

As discussed in Chapter 15, combustion efficiency can be defined in a number of equation forms:

$$\eta_c = \frac{\text{Enthalpy Rise (Actual)}}{\text{Enthalpy Rise (Ideal)}} = \frac{(h_4 - h_3)_a}{(h_4 - h_3)_i} \quad (20.2.1)$$

$$= \frac{\text{Temperature Rise (Actual)}}{\text{Temperature Rise (Ideal)}} = \frac{(T_4 - T_3)_a}{(T_4 - T_3)_i} \quad (20.2.2)$$

where: Subscript 4 represents the combustor exit condition

Subscript 3 represents the combustor entrance condition

Combustion efficiency (η_c) can also be determined from the concentration levels of the various exhaust products. A description of the combustion efficiency calculation based on exhaust product chemistry is given in Section 15.4 of Chapter 15.

Combustion efficiency can be empirically correlated with several aerothermodynamic parameters such as system pressure, temperature, reference velocity (V_a)*, and temperature rise. Two examples of such correlations will be discussed in 20.3.1.1.

20.2.1.2 Overall Pressure Loss: The combustion system total pressure loss from the compressor discharge to the turbine inlet is normally expressed as a percent of compressor discharge pressure. Losses of 5 - 8% are typically encountered in contemporary systems. Combustion system pressure loss is recognized as necessary to achieve certain design objectives (pattern factor, effective cooling, etc.), and can also provide a stabilizing effect on combustor aerodynamics. However, pressure loss also impacts engine thrust and specific fuel consumption. A 1% increase in pressure loss will result in approximately a 1% decrease in thrust and a .5 - .75% increase in specific fuel consumption. Consequently, design goals for pressure loss represent a compromise among the above factors.

Overall pressure loss is the sum of inlet diffuser loss, combustor dome and liner loss, and momentum loss resulting from combustor flow acceleration attendant with increased gas temperature (see Chapter 15, Section 15.3). Since many aspects of combustor performance are dependent on airflow turbulence generated within the combustor (which in turn depends on liner pressure drop), rapid and complete burning of the fuel and air is strongly influenced by the extent of pressure drop experienced as air is introduced into the combustion zone.

Combustion system pressure drop can be expressed in terms of three different loss parameters: fractional pressure loss, inlet velocity head loss and reference velocity head loss.

* That velocity at the reference plane, or plane of maximum cross section, within the combustor under flow conditions corresponding to T_3 . Values of reference velocity range from 15-30 meters per second for contemporary combustor designs.

a. Fractional Loss--Overall combustor/diffuser pressure loss is most commonly expressed as the fractional loss defined as:

$$\frac{\Delta P}{P_3} = \frac{P_3 - P_4}{P_3} \quad (20.2.3)$$

where $\Delta P = P_3 - P_4 =$ Pressure Drop

$P_3 =$ Compressor discharge total pressure

$P_4 =$ Turbine nozzle inlet or combustor exit total pressure

This loss generally increases with the square of the diffuser inlet Mach number.

b. Inlet Velocity Head Loss--

This loss coefficient is given in terms of inlet velocity head. It expresses losses in a manner which accounts for the additional difficulties in designing for minimum pressure loss as inlet velocities are increased. Inlet velocity head loss is defined as:

$$\frac{\Delta P}{q_3} = \frac{P_3 - P_4}{q_3} \quad (20.2.4)$$

where: $P_3 =$ Compressor discharge total pressure

$P_4 =$ Combustor exit total pressure

$q_3 =$ Dynamic pressure at the compressor discharge

c. Reference Velocity Head Loss--

This loss coefficient is expressed in terms of reference velocity. It represents a measure of the pressure loss normalized by a term which accounts for difficulties associated with high combustor volumetric flow rates. Reference velocity head loss is defined as:

$$\frac{\Delta P}{q_r} = \frac{P_3 - P_4}{q_r} \quad (20.2.5)$$

where: $P_3 =$ Compressor discharge total pressure

$P_4 =$ Combustor exit total pressure

$q_r =$ Dynamic pressure corresponding to V_R

The relationship between fractional pressure loss (or overall pressure loss) and reference velocity head loss is shown in Figure 20.2.1 as a function of reference Mach number.

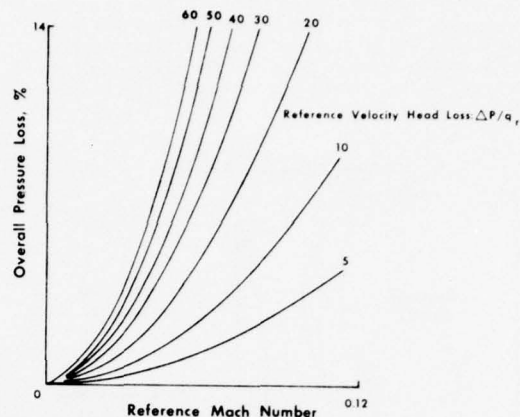

Figure 20.2.1 Pressure Loss Correlation

20.2.1.3 Exit Temperature Profile: A third performance parameter relates to the temperature uniformity of the combustion gases as they enter the turbine. In order to ensure that the proper temperature profile has been established at the combustor exit, combustion gas temperatures are often measured by means of high temperature thermocouples or via gas sampling techniques employed at the combustor exit plane. A detailed description of the thermal field entering the turbine both radially and circumferentially can be determined from this data. A simplified expression called pattern factor or peak temperature factor may be calculated from this exit temperature data. Pattern factor is defined as:

$$\text{Pattern Factor} = \frac{T_{\max} - T_{\text{avg}}}{T_{\text{avg}} - T_{\text{in}}} \quad (20.2.6)$$

where: $T_{\max} =$ Maximum measured exit temperature (local)

$T_{\text{avg}} =$ Average of all temperatures at exit plane

$T_{\text{in}} =$ Compressor discharge average temperature

Contemporary combustors exhibit pattern factors ranging from 0.25 to 0.45. Pattern factor goals are based primarily on the design requirements of the turbine first-stage vane which requires low gas temperatures at both the hub and tip of the turbine -- areas where high stresses and protective seals require cooler gas temperatures. Consequently, a pattern factor of 0.0 is not required. Durability considerations require high temperature rise combustors to provide combustor exit temperature profiles corresponding to pattern factors in the 0.15 to 0.25 range. One will note that although pattern factor is an important combustor design parameter, it describes the possible thermal impact on the turbine and is an important factor in matching the combustor and turbine components.

Although pattern factor defines the peak turbine vane inlet gas temperature, the shape of the combustor exit temperature radial profile is the critical factor controlling turbine blade life. Figure 20.2.2 illustrates typical

radial profile characteristics and their attendant relationship with pattern factor. By proper control of dilution air, the combustor exit temperature field is tailored to give the design pattern factor and radial profile consistent with turbine requirements.

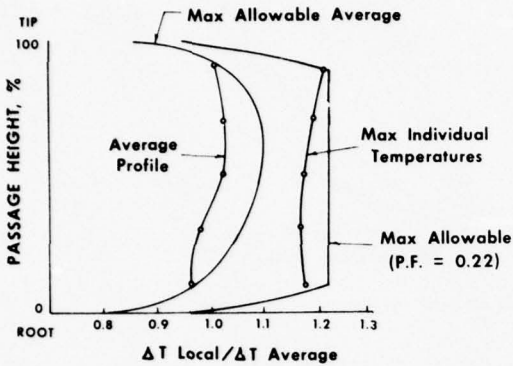

Figure 20.2.2 Radial Temperature Profile at Combustor Exit

20.2.1.4 Combustion Stability: Combustion stability is defined as the ability of the combustion process to sustain itself in a continuous manner. Stable, efficient combustion can be upset by the fuel-air mixture becoming too lean such that temperatures and reaction rates drop below the level necessary to effectively heat and vaporize the incoming fuel and air. Such a situation causes blowout of the combustion process. An illustration of stability sensitivity to mass flow, velocity and pressure characteristics as a function of equivalence ratio is given in Figure 20.2.3. These trends can be correlated with the perfectly stirred reactor theory described in Section 15.3 of Chapter 15.

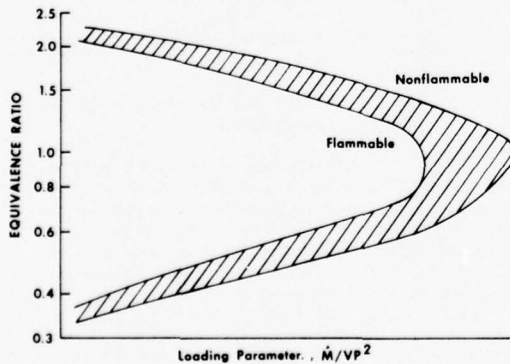

Figure 20.2.3 Combustion Stability Characteristics

20.2.1.5 Ignition: Ignition of a fuel-air mixture in a turbine engine combustor requires inlet air and fuel conditions within flammability limits, sufficient residence time of the potentially burnable mixture, and the location of an effective ignition source in the vicinity of the burnable mixture. Each of these factors has been

discussed from a fundamental standpoint in Section 15.4 of Chapter 15. Reliable ignition in the combustion system is required during ground-level startup and for relighting during altitude windmilling. The broad range of combustor inlet temperature and pressure conditions encompassed by a typical ignition/relight envelope is illustrated in Figure 20.2.4. It is well known that ignition performance is improved by increases in combustor pressure, temperature, fuel-air ratio, and ignition-source energy. In general, ignition is impaired by increases in reference velocity, poor fuel atomization, and low fuel volatility. A more extensive discussion of the ignition source itself is deferred to 20.2.2.5.

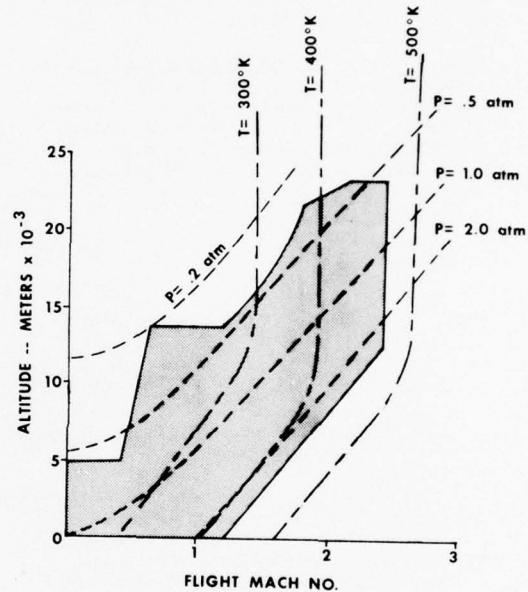

Figure 20.2.4 Ignition/Relight Envelope

20.2.1.6 Size, Weight, Cost: The main combustor of a turbine engine, like all other main components must be designed within constraints of size, weight, and cost. The combustor diameter is usually dictated by the engine casing envelope provided between the compressor and turbine and is never allowed to exceed the limiting diameter defined for the engine. Minimization of combustor length allows reduction of engine bearing requirements and permits substantial reductions in weight and cost. Advancements in design technology have permitted major reductions in combustor length. With the advent of the annular combustor design, length has been reduced by at least 50% when compared to contemporary cannular systems.

While reductions in both size and weight have been realized in recent combustor developments, the requirement for higher operating temperatures has demanded the use of stronger, higher temperature and more costly combustor materials (to be discussed in 20.2.2.6). Nevertheless, the cost of contemporary combustion systems including ignition and fuel injection assemblies remains at approximately 2 - 4 percent of the total engine cost. A tabulation of the approximate size, weight, cost and capacity of some contemporary combustion systems is given in Table 20.2.1.

Naturally, the final cost of any component is significantly affected by the level of production.

TABLE 20.2.1 Contemporary Combustor Size, Weight, and Cost

Type	TF39	TF41	JT9	JT9D	T63
<u>Mass Flow (Design Point)</u>					
Air Flow, lb/sec	178.	135.	162.	242.	3.3
Kg/sec	81.	61.	74.	110.	1.5
Fuel Flow, lb/hr	12,850.	9,965.	8,350.	16,100.	235.
Kg/hr	5,829.	4,520.	3,788.	7,303.	107.
<u>Size</u>					
Length, in	20.7	16.6	19.0	17.3	9.5
cm	52.6	42.2	48.3	43.9	24.1
Diameter, in	33.3	5.3/24.1*	6.5/32.0*	38.0	5.4
cm	84.6	13.5/61.2	16.5/81.3	96.5	13.7
Weight, lb	202.	64.	92.	217.	2.2
kg	92.	29.	42.	98.	1.0
Cost, \$	42,000.	17,000.	11,300.	80,000.	710.

* Can Diameter/Annulus Diameter

20.2.1.7 Durability, Maintainability, Reliability: A principal combustor design objective is to provide a system with sufficient durability to permit continuous operation until a scheduled major engine overhaul, at which time it becomes cost effective to make necessary repairs and/or replacements. In the case of the main burner, durability is predominantly related to the structural and thermal integrity of the dome and liner. The combustor must exhibit good oxidation resistance and low stress levels at all operating conditions if durability is to be achieved.

A maintainable component is one that is easily accessible, repairable and/or replaceable with a minimum of time, cost, and labor. While most combustor liners can be weld repaired, if damaged or burned, turbine removal is required for replacement of combustors in many cases. Consequently, a burner life consistent with the planned engine overhaul schedule is a primary objective. Combustor cases and diffuser sections require minimal maintenance and fuel nozzles and ignitors can generally be replaced and/or cleaned with minimal effort.

Reliability can be defined as the probability that a system or subsystem will perform satisfactorily between scheduled maintenance and overhaul periods. Component reliability is highly dependent on the aircraft mission, geographical location, and pilot operation since these factors strongly affect the actual combustor temperature-pressure environment and cyclic history of the components. In that the combustor has virtually no moving parts, its reliability is strongly related to fuel nozzle and ignitor performance. While Fouling and carboning of these subcomponents are common causes for engine rejection, these problems are relatively easy to correct through normal inspect and replace field maintenance procedures.

20.2.1.8 Exhaust Emissions: With the advent of environmental regulations for aircraft propulsion systems, the levels of carbon monoxide, unburned hydrocarbons, oxides of nitrogen, and smoke in the engine exhaust become important. Naturally, the environmental constraints directly impact the combustion system--the principal source of nearly all pollutants emitted by the engine. Major changes to combustor design philosophy have evolved in recent years to provide cleaner operation at all conditions without serious compromise to engine performance. A detailed discussion of the exhaust emissions area is offered in Section 20.4.1.

20.2.2 Design Factors

The turbine engine combustion system consists of three principal elements--the inlet diffuser, the dome and snout, and the inner and outer liners. In addition, two important subcomponents are necessary--the fuel injector and the ignitor. These elements are illustrated in Figure 20.2.5. This section will describe each of these items and will conclude with a materials summary.

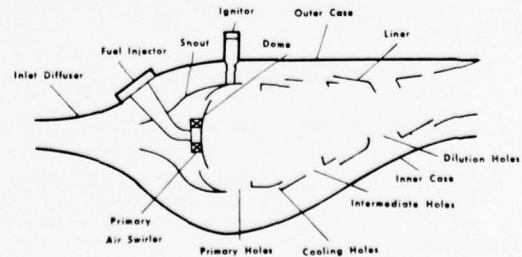

Figure 20.2.5 Component Identification

20.2.2.1 Inlet Diffuser: The purpose of the combustor inlet diffuser is to reduce the mean velocity of the air exiting the compressor and deliver it to the combustion chamber as a stable, uniform flow field recovering as much of the dynamic pressure as possible. Compressor discharge air velocities range from 90-180 meters per second; consequently, before this high velocity air is allowed to enter the combustor, it must be diffused to levels consistent with the stable, low pressure loss, high efficiency requirements of contemporary combustors. Additionally, this resulting flow field must be introduced in a relatively non-distorted manner to ensure uniform flow distribution to the combustion chamber. The diffuser must accomplish this by effectively controlling boundary layer growth and avoiding flow separation along the diffuser walls while minimizing length and overall size. A balance must be found between (a) designs with increased size and complexity and their attendant performance penalties, and (b) short-length, rapid divergence designs which have inherent flow non-uniformity and separation problems. Hence, the inlet diffuser represents a design and performance compromise relative to required compactness, low pressure loss and good flow uniformity.

A number of performance parameters are commonly used to describe a diffuser and its operation.

a. Pressure Recovery Coefficient

(C_p)--This is a measure of the pressure recovery efficiency of the diffuser reflecting its ability to recover dynamic pressure. The coefficient is defined as the ratio of static pressure rise to inlet dynamic head:

$$C_p = \frac{P_{S2} - P_{S1}}{\frac{\rho V_1^2}{2g}} \quad (20.2.7)$$

Where: P_{S2} = Exit static pressure

P_{S1} = Inlet static pressure

$\frac{\rho V_1^2}{2g}$ = Inlet dynamic pressure

For the ideal flow situation; i.e., full dynamic pressure recovery, C_p can be expressed in terms of area ratio:

$$C_p = 1 - \left(\frac{A_1}{A_2}\right)^2 \quad (20.2.8)$$

Where: A_1 = Inlet cross sectional area

A_2 = Exit cross sectional area

b. Pressure Recovery Effectiveness--This parameter describes

the ability of a diffuser design to achieve ideal recovery characteristics. Hence, it is the ratio of the actual to the ideal pressure-recovery coefficient:

$$\eta = \frac{C_p}{C_p^{Ideal}} = \frac{P_{S2} - P_{S1}}{\frac{\rho V_1^2}{2g} \left[1 - \left(\frac{A_1}{A_2}\right)^2 \right]} \quad (20.2.9)$$

c. Kinetic Energy Distortion

Factor (α)--This factor is a measure of the radial non-uniformity of the axial flow velocity profile. The distortion factor is defined as:

$$\alpha = \frac{\int_a (u^2/2) \rho dA}{(V^2/2) \rho A} \quad (20.2.10)$$

where: V = Mean flow velocity

u = Local axial velocity

ρ = Density

A = Cross-sectional area of duct

A factor of 1.0 is equivalent to a flat one-dimensional velocity profile (i.e. plug flow); turbulent pipe flow has a factor of approximately 1.1.

In addition, a number of design parameters are often utilized to predict diffuser performance.

a. Area Ratio (A_r)--This is the ratio of the exit to inlet areas of the diffuser and defines the degree of area change for a particular design.

b. Length-to-Height Ratio (L/H)--This is the ratio of diffuser length (entrance to exit) to the entrance or throat height and serves as a sizing parameter.

c. Divergence Half-Angle (θ)--This is equivalent to one-half the equivalent cone angle of the diffuser and describes the geometric divergence characteristics of the diffuser walls.

Figure 20.2.6 relates area ratio, length-to-height ratio and divergence half-angle to pressure recovery effectiveness.

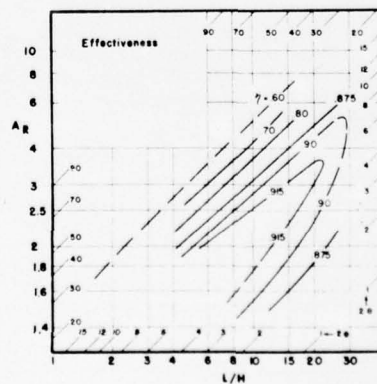
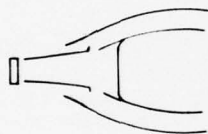

Figure 20.2.6 Diffuser Design and Performance Characteristics

Early inlet diffuser designs were of the smooth curved wall or contoured wall designs. Because of the wide variations in flow-field characteristics exiting the compressor, however, the curved wall diffuser cannot always provide uniform, non-separated flow at all operating conditions. This can become a critical problem in the short length diffusers required of many current systems. Consequently, a trend toward dump or combination curved wall and dump diffuser designs is occurring. Although this design results in somewhat higher pressure losses, it provides a known and constant point of flow separation, the dump plane, which prevents stalled operation at all diffuser entrance conditions. Figure 20.2.7 illustrates these contemporary designs.



CURVED WALL DIFFUSER



DUMP DIFFUSER

Figure 20.2.7 Contemporary Diffuser Designs

The design procedures commonly employed to develop a specific diffuser configuration involve the use of a combination of experimentally generated performance maps, empirical equations, and analytical models. Most available performance maps were generated for two-dimensional straight wall and conical diffusers, the most notable source being the work of Klein and his associates (Ref. 20.7). Until recent years, empirical results such as those illustrated in Figure 20.2.6 have been used in the development of annular diffusers. However, with the advent of improved numerical methods and high speed computers, a number of improved two-dimensional and three-dimensional analytical models are now being developed which more accurately describe the flow-field characteristics of the annular diffuser design. Such programs will provide improved analysis of pressure loss characteristics, inlet velocity profile effects and the influence of turbulence level on diffuser performance.

The need for high performance in short compact diffusers takes on increasing importance as future engine operating conditions become more and more severe. An advanced compact diffuser design which provides improved boundary layer control and greater pressure recovery is described in 20.4.3.2.

20.2.2.2 Dome and Snout--At the front of the combustion chamber is the snout and dome where air and fuel are initially introduced. The snout is actually a forward extension to the dome dividing

the incoming air into two streams--one directly entering the primary zone of the combustor through air passages in the dome, the other entering the annulus around the combustor. The snout also improves diffusion by streamlining the combustor dome, permitting a larger diffuser divergence angle and providing reduced overall diffuser length. The dome plate contains provisions for receiving the fuel injector and maintains its alignment during operation. Combustor domes are of two basic types--bluff-body and swirl stabilized as illustrated in Figure 20.2.8. Early combustors like the J79 (Figure 20.1.4) generally fall into the bluff-body class wherein the high blockage dome plate establishes a strong wake region providing primary zone recirculation. In effect, the bluff-body dome interacts with the first row of primary zone air holes to establish this strong recirculation region. Most contemporary combustors, however, utilize the swirl-stabilized dome. With this design, the fuel-injector is surrounded by a primary air swirler. The air swirler sets up a strong swirling flow field around the fuel nozzle generating a centralized low pressure zone which draws or recirculates hot combustion products into the dome region. As a result, an area of high turbulence and flow shear is established in the vicinity of the fuel nozzle finely atomizing the fuel spray and promoting rapid fuel-air mixing.

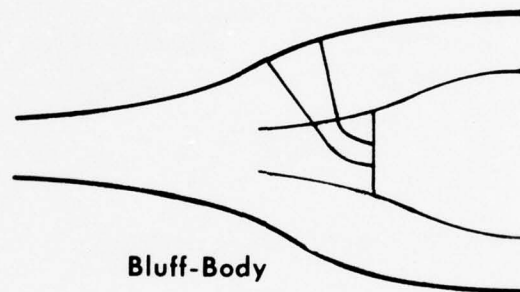

Bluff-Body
Stabilized

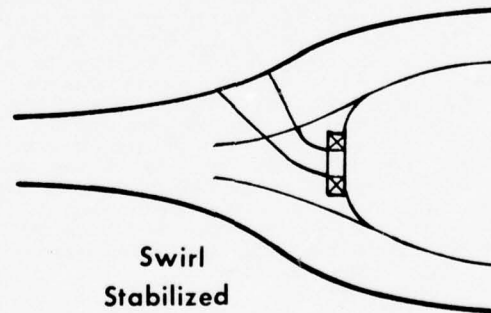

Swirl
Stabilized

Figure 20.2.8 Combustor Dome Types

20.2.2.3 Liner: The liner provides containment of the combustion process and allows introduction of intermediate and dilution air flow. Contemporary liners are typically of sheet-metal braze and welded construction. The liner is mounted to the combustor dome and generally suspended by a support and seal system at the turbine nozzle entrance plane. Its surface is often a system of holes of varying sizes which direct

primary, intermediate, dilution, and liner cooling air into the combustion chamber. While combustion gas temperatures may be in excess of 2500°K, the liner is protected by a continuous flow of cool air (at approximately compressor exit temperature levels) and maintained at temperatures less than 1200°K.

The liner must be designed with high structural integrity to support forces resulting from pressure drop and must have high thermal resistance capable of continuous and cyclic high temperature operation. This is accomplished through utilization of high strength, high temperature oxidation-resistant materials and effective use of cooling air. Depending upon the temperature rise requirements of the combustor, 20-50 percent of the inlet airflow may be utilized in liner cooling. A number of cooling techniques are illustrated in Figure 20.2.9.

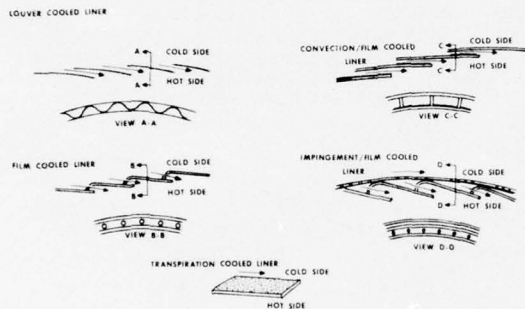

Figure 20.2.9 Combustor Cooling Techniques

a. Louver Cooling--Many of the early jet engine combustors used a louver cooling technique in which the liner was fabricated into a number of cylindrical panels. When assembled, the liner contained a series of annular air passages at the panel intersection points, the gap heights of which were maintained by simple wiggle-strip louvers. This permitted a film of air to be injected along the hot side of each panel wall providing a protective thermal barrier. Subsequent injection downstream through remaining panels permitted replenishment of this cooling air boundary layer. Unfortunately, the louver cooling technique did not provide accurate metering of the cooling air which resulted in considerable cooling flow nonuniformity with attendant variations in combustor exit profiles and severe metal temperature gradients along the liner.

b. Film Cooling--This technique is an extension of the louver cooling technique but with machined injection holes instead of louvers. Consequently, airflow metering is more accurate and uniform throughout the combustion chamber. Most current combustors use this cooling technique. However, increased operating gas temperatures of future combustors will result in less air for cooling and more advanced cooling techniques/materials will be required.

c. Convection/Film Cooling--This relatively new technique* permits much reduced cooling air flow (15 - 25 percent) while providing high cooling effectiveness and uniform metal temperatures. It is particularly suited to high temperature rise combustion systems where cooling air is at a premium. The convection/film cooled liner takes advantage of simple but controlled convection cooling enhanced by roughened walls while providing the protective boundary layer of cool air at each cooling panel discharge plane. Although somewhat similar in appearance to the louver cooled liner, the convection/film coolant passage is several times greater; more accurate coolant metering is provided and a more stable coolant film is established at the panel exit. Principal disadvantages of this design are somewhat heavier construction, increased manufacturing complexity and repairability difficulties.

d. Impingement/Film Cooling--This cooling technique is also well suited to high temperature rise combustors. When combined with the additional film cooling feature, impingement cooling provides for excellent thermal protection of a high temperature liner. Its disadvantages, however, are similar to those of the film/convection liner--heavier construction, manufacturing complexity and repairability difficulties.

e. Transpiration Cooling-- This is the most advanced cooling scheme available and is particularly well-suited to future high temperature applications. Cooling air flows through a porous liner material, uniformly removing heat from the liners while providing an excellent thermal barrier to high combustion gas temperatures. Both porous (regimesh and porolloy) and fabricated porous transpiring materials (Lamilloy**) have been examined experimentally. Fabricated porous materials tend to alleviate plugging and contamination problems, inherent disadvantages of the more conventional porous materials.

Figure 20.2.10 shows the axial thermal gradient characteristics of each of the liner designs discussed above as a function of relative liner length. As can be seen, transpiration cooling offers better temperature control and uniformity than any other cooling technique.

20.2.2.4 Fuel Injection--Basically four methods of fuel introduction are currently used or proposed for future use. These techniques--pressure atomizing, air blast, vaporizing, and premix/prevaporizing--are discussed below in increasing order of complexity. Each of these is illustrated in Figure 20.2.11.

a. Pressure Atomizing--Most contemporary combustion systems use pressure atomizing fuel injectors. They are relatively simple in construction, provide a broad flow range and can provide excellent fuel atomization when fuel system pressures are high. A typical pressure atomizing fuel injector is illustrated in Figure 20.2.12. At least five different design concepts or variations are included in this category: simplex, duplex, dual

* Patent Pending--Patent Application Numbers SN 876,264 & SN 298,434, titled "Combustion Liner"

**Developed by Detroit Diesel Allison, Div of GMC, Patent Number 3,584,972, titled "Laminated Porous Material," 15 June 1971.

orifice, variable area, and slinger. These devices typically utilize high fuel pressure (about 500 psi above combustor pressure) to achieve fine fuel atomization. The slinger design, although a pressure atomizing type, is very different from the conventional fuel nozzle in that the fuel is injected through small holes in the rotating turbine shaft. The high centrifugal forces imparted to the fuel provide atomization. Slinger systems are used in several small engine combustors--the WR19 of Figure 20.1.6 is one such system. The principal disadvantages of the pressure atomizing systems are the propensity for fuel system leaks due to the inherently high fuel pressures required, potential plugging of the small fuel orifices by contaminants entrained in the fuel, and increased difficulty in achieving low smoke levels when fuel system pressures are low.

the combustion zone. During operation, the heat transferred from the combustion region partially vaporizes the incoming fuel, while the liquid/vapor fuel within the tube provides thermal protection for the tube. It is generally agreed, however, that fuel vaporization is very much incomplete in this type vaporizer and is considered by many to be merely an extension of the airblast principles described above. This design is simple in construction, inexpensive, and can operate with low fuel injection pressures. The resultant fuel-air mixture burns with low flame radiation reducing liner heat loads. This design, however, has certain serious shortcomings: poor ignition and lean blowout characteristics, vaporizer tube durability problems during low fuel flows, and slow system response time.

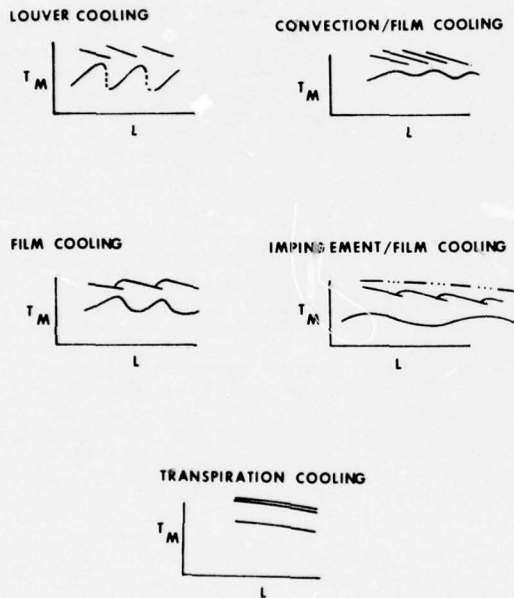

Figure 20.2.10 Liner Cooling Characteristics

b. Airblast--A number of modern combustor designs achieve fuel atomization and mixing through use of primary zone air momentum. Strong swirling motion, often accompanied by a second counter swirl, causes high gas dynamic shear forces to atomize liquid fuel and promote mixing. Low fuel injection pressures (50 - 200 psi above combustor pressure) are utilized in these schemes. Rizkalla and Lefebvre (Ref 20.8, 20.9) describe airblast atomizer spray characteristics relative to air and liquid property influences. In addition, the development of a specific airblast atomizer for gas turbine application is discussed in Reference 20.10.

c. Vaporizing: A number of vaporizing fuel injection systems have been developed; perhaps the most common is the "candy-cane" vaporizer. In this design, fuel and air are introduced into a cane-shaped tube immersed in

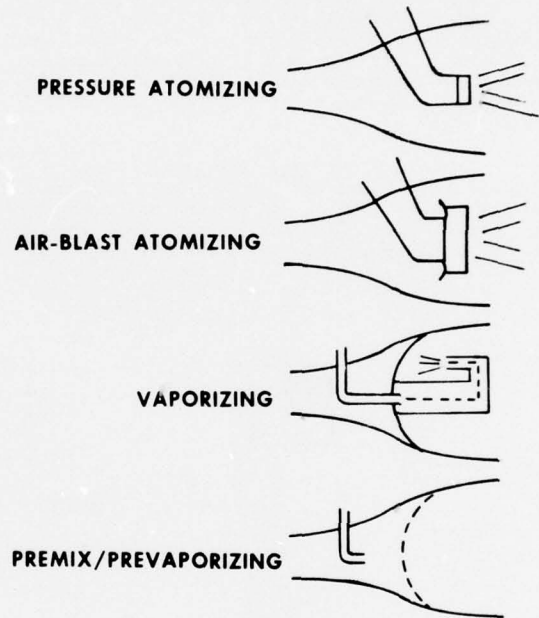

Figure 20.2.11 Fuel Injection Methods

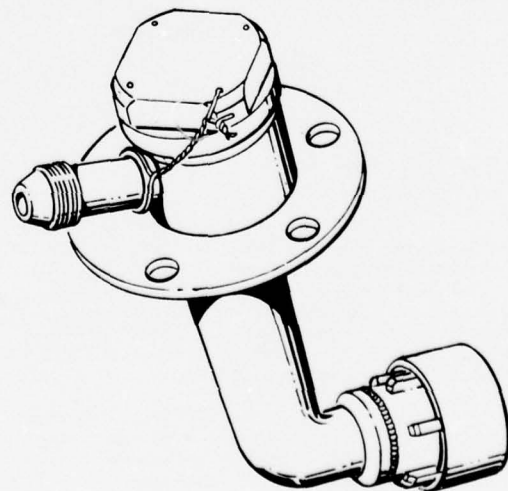

Figure 20.2.12 Pressure Atomizing Fuel Injector

d. Premix/Prevaporizing--The advent of gas turbine emission regulations has resulted in increased interest in premix/prevaporizing fuel injection. In this technique, fuel is introduced and premixed with the incoming air prior to introduction to the combustion zone. The design intent is to provide a uniform, low equivalence ratio, fully mixed field of vaporized fuel in the combustion region. As a result, low smoke and chemical emissions, low flame radiation, improved fuel-air uniformity in the combustion region and virtual elimination of hot-spot burning occurs. Potential problem areas with this system include incomplete fuel vaporization, danger of flashback through or auto ignition of the fuel-air pre-mixture upstream of the combustor dome plate with resulting damage to the combustor hardware, poor lean blowout characteristics, and difficulty with ignition and altitude relight. Staged combustion, utilizing a pilot zone with a relatively conventional stoichiometric design, is often proposed as a method of overcoming stability and ignition difficulties.

20.2.2.5 Ignition: Ignition of the cold flowing fuel-air mixture can be a major combustor design problem. Nearly all conventional combustors are ignited by a simple spark-type igniter similar to the automotive spark plug. Turbine engine ignition energies are typically 4 to 12 joules with several thousand volts at the plug tip. Figure 20.2.13 illustrates a typical spark type igniter.

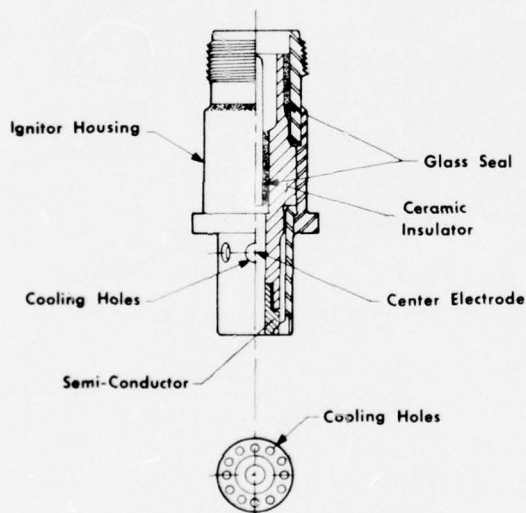

Figure 20.2.13 Spark Igniter

Each combustion system is generally fitted with two spark igniters to provide system redundancy. Potential ignition system problems include spark plug fouling with carbon or fuel, plug tip burn-off, electrode erosion with time and corona-discharge losses along the ignition system transmission lines under high altitude, low pressure conditions.

During engine start-up, the flame must propagate from can-to-can in a cannular combustion system via cross-fire or inter-connector tubes located near the dome of each can. The large cross-fire ports of the J79 are readily visible in Figure 20.1.4. The cross-fire region

must be designed to insure rapid and complete flame propagation around the combustion system. Without proper cross-firing, a "hung start" can occur wherein only one or two combustors are ignited. This condition of poor flame propagation can also occur in annular combustors. In either case, severe local gas temperatures (high pattern factor) are generated which can thermally distress the turbine.

Although the spark igniter is the most common ignition source in use today, a number of other ignition or ignition-assist techniques have been employed: the torch igniter, oxygen injection, and the use of pyrophoric fuels. The torch igniter, a device combining the functions of fuel injection and spark ignition, is extremely reliable and permits a wide ignition envelope. However, it is more complex and costly and increases maintainability problems relative to conventional ignition systems. Oxygen injection assists ignition by lowering minimum ignition energy requirements. It is especially applicable to facilitating altitude relight. The use of pyrophoric fuels provides perhaps the most positive ignition source available. Pyrophorics will react spontaneously in the presence of oxygen and provide excellent altitude relight capability. Unfortunately, pyrophoric fuels are extremely toxic and create special handling and logistics problems. Consequently, these factors have limited its use as a viable ignition technique.

20.2.2.6 Materials: The selection of proper materials is a critical element in combustion system design for component structural integrity. Materials which possess high stress tolerance, good oxidation and corrosion resistance, and the ability to withstand the broad cyclic aero-thermal loads imposed by the engine during its operation are required. Several high strength alloy materials are used in combustors today, the selection of which is generally based on the projected operating environment of the propulsion system. This section will highlight a few of the more common combustor materials in use today.

a. Hastelloy X--Hastelloy X is a nickel-base alloy strengthened in solid solution by chromium and molybdenum. It is the most common combustor liner material in use today. Its formability is good, its machinability is difficult but not impractical and its weldability and brazing characteristics are good. Hastelloy X exhibits good strength and oxidation properties in the 1040°K to 1140°K metal temperature range. Most combustors with Hastelloy X liners are designed to operate at metal temperatures of 1090°K to 1120°K.

b. Haynes 188: Haynes Alloy 188 is a wrought solid, solution strengthened, cobalt-base alloy applicable to static parts operating at temperatures up to 1370°K. It can be readily formed and welded, its oxidation resistance is good although protective coatings are required for applications above 1250°K, and like Hastelloy X, its machinability is difficult but not impractical. It is finding increased applicability in the newer combustion systems where liner metal temperatures of 1140°K to 1230°K are necessary.

c. TD Nickel: This super alloy is a non-heat-treatable, high nickel alloy strengthened by dispersion of fine ThO₂ particles in a nickel matrix. This alloy maintains useful strengths at temperatures up to 1420°K. Its oxidation-erosion resistance is inferior to

Hastelloy X or Haynes 188 and requires protective coatings for applications above 1220°K. Its machinability and formability are good. Fusion and resistance welding of this material can be difficult; however, its brazeability is considered good. TD Nickel offers considerable promise in future high temperature liner applications where metal temperatures greater than 1250°K may be common. Current material costs and the need for protective coatings, however, have generally precluded serious consideration of TD Nickel in contemporary combustion systems. Further, advanced liner cooling techniques have succeeded in maintaining metal temperatures at levels consistent with the Hastelloy X/Haynes 188 material capabilities.

Significant advancements in super alloy technology are required to meet future high temperature rise combustor requirements. New materials well beyond the capability of TD Nickel will be necessary. Improved coatings may provide part of the solution if developed with long life and improved high and low cycle fatigue capabilities. Ceramics and advanced thermal barrier and coating materials may also find a role in future combustor design.

20.3 DESIGN TOOLS

The complexity of the aerothermodynamic and chemical processes occurring simultaneously in the combustor prevent a purely analytical approach to component design and performance prediction. Insufficient capability to accomplish measurements of importance within the combustor has precluded all but the most basic understanding of practical gas turbine combustion processes. As a result, one has had little choice but to formulate new designs largely on the basis of personal or organizational experience. Continuation of this approach to combustor design for high temperature sophisticated systems under development today and in the future would be extremely costly and time consuming. The turbine engine industry can no longer afford to conduct component development activities on a generally empirical basis. Hence, significant R&D programs are now being directed toward developing improved analytical design procedures reinforced by more powerful measurement diagnostics.

20.3.1 Combustor Modeling

The principal objective of the combustion system model is to analytically describe and predict the performance characteristics of a specific system design based on definable aerodynamic, chemical, and thermodynamic parameters. Many modeling approaches describing the flow field and characteristics of a particular combustion system have evolved over the past twenty years. Early models were almost entirely empirical while the newest models currently under development are based more on fundamental principles. Improved computer availability and capability as well as more efficient numerical techniques have had a significant impact on combustion modeling by permitting the more complex, theoretically-based approaches to be considered.

20.3.1.1 Empirical: The empirical model utilizes a large body of experimental data to develop a correlation often using multiple-regression analysis techniques. Such an approach

involves a selection of the appropriate design and aerothermodynamic parameters which have been empirically found to influence the performance (e.g., combustion efficiency) of a particular combustor design. Each of the non-dimensionalized parameters or ratios are acted upon by appropriate "influence" coefficients or exponents, the value of which reflects the degree of importance of a particular parameter. Since these influence terms are usually derived from test data obtained from combustors which generally represent the same basic design family, a major change in design philosophy can require the definition of a new set of influence factors. Consequently, this modeling approach works well on specific combustor designs for which there is a broad base of technical data. Unfortunately, it cannot be arbitrarily used as a general design tool. One example of an empirical correlation model is illustrated in Figure 20.3.1. In this model, combustion system efficiency is defined as a function of the more important combustor design and performance parameters. As can be seen, the model is written in general form and a tabulated listing of appropriate coefficients and exponents is provided to permit the computation of combustion efficiency. Again, these influence terms are empirically based and were derived from a bank of combustor data representative of a particular class of combustors.

$$E.C. = C \left(\frac{M_2/P_2}{4.5} \right)^A \left(\frac{T_2}{1000} \right)^B \left(\frac{P_1}{1000} \right)^C \left(\frac{L_c}{12} \right)^D \left(\frac{P/P_0}{10} \right)^E \left(\frac{V_1/V_2}{10} \right)^F \left(\frac{M_1/M_2}{0.5} \right)^G \left(\frac{H_1}{6} \right)^H$$

DETERMINE:	COMBUSTION EFFICIENCY	
	T: 600° to 1600°F	T: 1600° to 2500°F
C	0.88	0.79
A	0.5	0.04
B	0.22	-0.04
C	0.11	-0.09
D	0.14	0.16
E	0.07	0.07
F	-0.07	0.3
G	-0.10	0.23
H	0.3	0.3

Figure 20.3.1 Empirical Combustion Efficiency Correlation

A second empirical correlation employed by some combustor designers today defines a reaction rate parameter (θ) based on the "burning velocity" theory of Lefebvre (Ref 20.11). The θ -parameter is given in Figure 20.3.2. The resulting correlation establishes the relationship between combustor efficiency, operating condition and geometric size. One can see that efficiency is not only a function of airflow, inlet pressure, and inlet temperature, but also is strongly dependent on combustion zone fuel-air ratio. Herbert (Ref 20.12) estimated the effect of equivalence ratio on reaction rate by the following equation:

$$b = 220 (\sqrt{\phi} + \ln \phi / 1.03), \quad (20.3.1)$$

where ϕ is primary zone equivalence ratio. A graphic illustration of the above expression (Figure 20.3.3) describes the variation of b with primary zone equivalence ratio. Hence, to achieve maximum efficiency, a primary zone fuel-air ratio of 0.067 ($\phi = 1$) should be used.

necessary. Further, new, laser-based combustion diagnostic measurement equipment can be expected to play an important role in the future. Techniques such as laser Raman scattering and coherent anti-Stokes Raman scattering hold new promise for fundamental studies of combustion processes requiring real-time "point" (=1 mm) measurements of temperature, concentration, and velocity. Other simpler methods may find application in measurement of combustor exit temperature profiles during combustion system development.

20.4 FUTURE REQUIREMENTS

The aero-propulsion combustion community is currently confronted with two new and difficult challenges: reduction of exhaust pollutant emissions and accommodation of new fuels which will reduce cost while increasing availability. The first two of the following three subsections summarize the problems and current state-of-the-art in each of these two areas. Further, projected engine technology requirements necessitate advancements in combustion system design techniques and performance. Section 20.4.3 addresses the combustion engineer's task in this area.

20.4.1 Exhaust Emissions

20.4.1.1 Problem Definition: In recent years, increased citizen concern over environmental issues coupled with the obvious visible smoke emissions from jet aircraft has brought substantial public attention to aircraft-contributed pollution. As airport traffic increased, it became evident that at least the possibility existed that pollutant emissions, when concentrated in the local airport environment, could result in ambient levels which exceed allowable limits. Concern within the United States culminated in the inclusion of exhaust emissions from aircraft engines in the considerations of the Clean Air Act Amendments of 1970 (Ref 20.18). This legislation requires that the Environmental Protection Agency (EPA) assess the extent to which aircraft emissions affect air quality, determine the technological feasibility of controlling such emissions and establish aircraft emissions standards, if necessary.

The resulting EPA assessment (Ref 20.19) has indicated the necessity to regulate commercial aircraft emissions. Currently, EPA standards (Ref 20.20) apply to commercial and general aviation but not to military aircraft. The following excerpt from EPA's discussion accompanying the final announcement of the aircraft emissions standards (Ref 20.20) summarizes this policy.

In judging the need for the regulations, the Administrator has determined:

(1) that the public health and welfare is endangered in several air quality control regions by violation of one or more of the national ambient air quality standards for carbon monoxide, hydrocarbons, nitrogen oxides, and photochemical oxidants, and that the public welfare is likely to be endangered by smoke emissions; (2) that airports and aircraft are now, or are projected to be significant sources of emissions of carbon monoxide, hydrocarbons, and nitrogen oxides in some of the air quality control regions in which the national ambient air quality standards are being violated, as well as being significant

sources of smoke, and therefore (3) that maintenance of the national ambient air quality standards and reduced impact of smoke emissions requires that aircraft and aircraft engines be subject to a program of control compatible with their significance as pollution sources. Accordingly, the Administrator has determined that emissions from aircraft and aircraft engines should be reduced to the extent practicable with present and developing technology. The standards proposed herein are not quantitatively derived from the air quality considerations ... but, instead, reflect EPA's judgment as to what reduced emission levels are or will be practicable to achieve for turbine and piston engines.

Current EPA regulations are based on reducing aircraft engine emissions during their operation below 3000 feet. However, an additional potential problem has been associated with aircraft--the possible environmental impact of high altitude emissions (Ref 20.21). There are many mechanisms by which this might arise: (a) emission of water vapor and carbon dioxide into the stratosphere may cause a "greenhouse effect." (b) sulphur compound emissions can cause particulate formation which would cause solar radiation to be diverted away from the earth's surface reducing the equilibrium atmospheric temperature, and (c) increased concentrations of water vapor and oxides of nitrogen due to emissions into the stratosphere might deplete the ozone layer and allow increased penetration of solar ultraviolet radiation. Potential problem (a) has been shown not to be significant. Much more investigation is needed concerning (b) and (c), however, before the extent of potential stratospheric environmental problems can be suitably defined.

The discussion which follows defines the exhaust gas content, presents engine emission characteristics, and reviews emissions control technology.

20.4.1.2 Exhaust Content: Aircraft engine exhaust constituents usually considered to be pollutants are smoke, carbon monoxide (CO), hydrocarbons (HC), and oxides of nitrogen (NO_x)*. The magnitude of emissions depends on operating mode and engine type. The combustion products are conveniently organized into five groups, as listed in Table 20.4.1. More than 99 percent of the exhaust products are in the first two categories, which include those species not generally considered to be objectionable. The last three categories contain small quantities of constituents and are dominated by the principal pollutants: hydrocarbons (HC), carbon monoxide (CO), oxides of nitrogen (NO_x), and smoke. Because emissions characteristics^x at engine idle, nonafterburning high power, and afterburning operation vary substantially, columns listing composition for each of these operating modes are given. Note that levels given in Table 20.4.1 correspond to the turbojet case or to the core flow only in the case of a turbofan.

* Exhaust nitrogen oxides are in the form of both NO and NO₂. Collectively, they are expressed as NO_x.

TABLE 20.4.1 Engine Combustion Products

Group	Type	Species	Approximate Concentration		
			Low Power (Idle) Concentration	High-Power (non AB) Concentration	Cruise (With Afterburner) Concentration
1.	Air	N ₂	77%	77%	73-76%
		O ₂	17.3-19%	13-16.3%	0-13%
		Ar	.9%	.9%	.9%
2.	Products of Complete Combustion	H ₂ O	1.4-2.4%	3-5%	5-13%
		CO ₂	1.4-2.4%	3-5%	5-13%
3.	Products of Incomplete Combustion	CO	50-2000 ppmv	1-50 ppmv	100-2000 ppmv
		Total HC	50-1000 ppmC	1-20 ppmC	100-1000 ppmC
		Partially Oxidized HC	25-500 ppmC	1-20 ppmC	?
		H ₂	5-50 ppmv	5-100 ppmv	100-1000 ppmv
		Soot	.5-25 ppmw	.5-50 ppmw	.50-50 ppmw
4.	Non-hydrocarbon Fuel Components	SO ₂ , SO ₃	1-5 ppmw	1-10 ppmw	1-30 ppmw
		Metals, Metal Oxides	5-20 ppbw	5-20 ppbw	5-20 ppbw
5.	Oxides of Nitrogen	NO, NO ₂	5-50 ppmv	50-500 ppmv	100-600 ppmv

a. Group 1, Air: These species pass through the engine unaffected by the combustion process and unchanged in chemical composition, except for oxygen depletion due to fuel oxidation. Argon is clearly inert. Although molecular nitrogen is nearly inert, the less than 0.01 percent that undergoes "fixation" to its oxide form (Group 5) is, of course, extremely important.

b. Group 2, Products of Complete Combustion: Water and carbon dioxide are the dominant combustion products and the fully oxidized forms of primary fuel elements, hydrogen and carbon. It is the formation of these species that releases maximum energy from the fuel. H₂O and CO₂ are not generally considered to be air pollutants.

c. Group 3, Products of Incomplete Combustion: Hydrogen and carbon not converted to water or carbon dioxide are found in compounds categorized as products of incomplete combustion. The important species in this group are carbon monoxide, unburned and partially oxidized hydrocarbons, molecular hydrogen, and soot.

CO and HC emissions contain the largest portion of unused chemical energy within the exhaust during idle operation. Combustion efficiency at this operating condition may be calculated from exhaust CO and HC concentration data. At higher power settings, especially with afterburner operation, H₂ levels may also significantly contribute to inefficiency. Exhaust hydrocarbons are usually measured as total hydrocarbons as specified by the SAE ARP 1256 (Ref 20.22). Although it is well known that the toxicological and smog-producing potential of different hydrocarbon types varies widely, little work has been done to characterize the distribution of hydro-

carbon types in the exhaust.* Presently available analytical techniques to accomplish such a characterization are complex, time consuming, expensive, and of unconfirmed accuracy.

A similar problem exists in quantifying soot emissions. The measurement technique that has evolved, ARP 1179 (Ref 20.23), does not directly relate to exhaust visibility or soot concentration. However, Champagne (Ref 20.24) has developed a correlation between measured ARP 1179 smoke number (SN) dry and particulate emissions. Efforts to measure and characterize particulate emissions directly are currently in progress. Complications have developed because the contribution of condensed hydrocarbons in the exhaust to the particulate measurement varies greatly with sampling conditions. Although a technique to determine exhaust soot concentrations may eventually be developed, characterization of size distribution appears to require a longer range effort.

d. Group 4, Non-Hydrocarbon Fuel Components: The elemental composition of petroleum-based fuel is predominantly hydrogen and carbon. Of its trace components, sulfur is the most abundant. Most of the sulfur in the exhaust is in an oxidized form, probably as sulfur dioxide. Giovanni and Hilt (Ref 20.30) and Slusher (Ref 20.31) have found that the ratio of SO₂ to SO₃ is from 0.03 to 0.14 in the case of heavy-duty stationary and aircraft gas turbines. The total amount of sulfur in exhaust compounds is directly related to, and calculable from, fuel sulfur content. The second most abundant

*Existing data can be found in Bogdon and McAdams (Ref 20.25), Groth and Robertson (Ref 20.26), Kendall and Levins (Ref 20.27), Butze and Kendall (Ref 20.28), and Katzman and Libby (Ref 20.29).

trace component of non-hydrocarbon fuel involves metals. It is expected that these elements, which may be either natural components of the fuel or additions to it, appear in the exhaust as metal oxides. Further, it is generally expected that these species are particulates and often found with the soot.

e. Group 5, Oxides of Nitrogen:

Although the ratio of NO to NO₂ emitted by aircraft gas turbines may shift with operating conditions, NO will eventually be converted to NO₂ in the atmosphere and subsequently participate in smog formation chemistry. Some attention, however, must be paid to the influence of time delay required for atmospheric NO₂ formation and the subsequent effect on smog formation. Stratospheric NO and NO₂ emissions are generally thought to have equally detrimental effects.

As stated above, product species are usually measured in terms of their volume (or sometimes mass, especially for condensed phases) fraction in the product sample. Occasionally, the suffix "dry" or "wet" is appended, according to whether or not the water is removed before analysis. A more useful and unambiguous method of reporting exhaust emissions from gas turbines has proved to be the use of an emission index which represents the ratio of the pollutant mass to the fuel consumption. A commonly used dimension is grams of pollutant per kilogram of fuel. Conversion of volume fraction measurements to emission indices requires assignment of molecular weights, which is not difficult for a single compound category, but may lead to confusion for categories consisting of more than one compound. It is conventional to report oxides of nitrogen (NO_x) as though they were entirely NO₂. Similarly, the oxides of sulfur (SO_x) are usually reported as SO₂. Hydrocarbon measurements usually lead to a volumetric fraction related to a single hydrocarbon compound; e.g., parts per million equivalent hexane (or methane, propane, carbon atom, etc.). In reducing these measurements to an emission index, a hydrogen-carbon ratio of two is usually assumed.

20.4.1.3 Engine Emissions Characteristics:

Processes that influence pollutant formation occur within both the main burner and afterburner. Conditions under which combustion occurs in these two systems are extremely different, and studies of emissions from the main burner and augmentor are generally treated separately.

a. Main Burner Emissions:

Carbon monoxide and hydrocarbon emissions are a strong function of engine power setting. As thrust is increased, the combustion system experiences greater inlet temperature and pressure, as well as higher fuel-air ratio. The increased fuel flow results in improved fuel atomization and higher combustor inlet temperature provides more rapid vaporization. Chemical reaction rates responsible for CO and HC consumption are sharply increased by higher flame temperatures resulting from the greater fuel-air ratio (See Section 15.1 of Chapter 15). Each of these changes tends to decrease the rates at which HC and CO are emitted. Consequently, the relationship between an engine's emission of HC and CO (or combustion inefficiency) and power setting indicates a sharply decreasing trend. Idle CO and HC emissions far exceed that at other engine conditions. A correlation of idle CO and hydrocarbon emissions for a number of engines can be established by plotting these values as a function

of combustor inlet temperature. Figure 20.4.1 illustrates the trends that can be obtained.

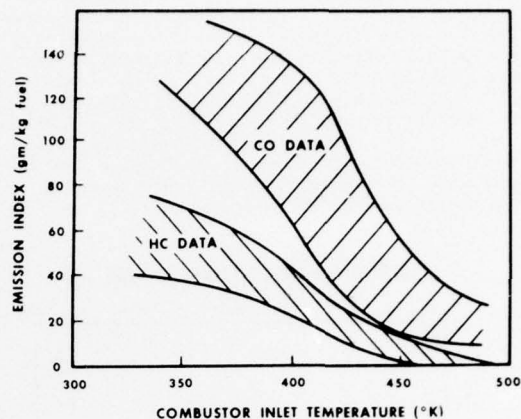

Figure 20.4.1 CO and HC Idle Emissions

As discussed in Chapter 15, combustion efficiency can be related to exhaust content. In the case of idle operation, the inefficiency is predominantly due to CO and HC. The idle CO and HC emission index values can be related to combustion inefficiency by the following equation:

$$1 - \eta_b = [0.232 (EI)_{CO} + (EI)_{HC}] \times 10^{-3} \quad (20.4.1)$$

where: η_b = Combustion efficiency

$1 - \eta_b$ = Combustion inefficiency

$(EI)_i$ = Emission index of species *i*.

Oxides of nitrogen emission levels are greatest at high-power operating conditions. The predominant NO forming chemical reaction is:

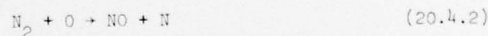

It is usually assumed that NO formation takes place in regions of the combustor where oxygen atoms are present at their equilibrium concentration. Reaction 20.4.2 and the oxygen atom concentration are extremely temperature sensitive; NO is produced only in the highest temperature (near-stoichiometric) combustion zones. Since the stoichiometric flame temperature is dependent on combustor inlet temperature (a function of compressor pressure ratio and flight speed) oxide of nitrogen emissions can be expected to increase substantially with power setting.

An excellent correlation of NO_x emissions from a large number of engines has been established by Lipfert (Ref 20.32). This correlation, reproduced in Figure 20.4.2, relates NO_x emission index to combustor inlet temperature. Note the strong temperature dependence previously discussed. Moreover, the fact that combustor

design has little apparent effect on NO_x emission is noteworthy. This implies that mixing^x and quenching processes within combustors operating with rich ($\phi > 1.0$) primary zones are strikingly similar; the temperature effect alone controls the NO_x emission rate. No strong fuel effects are apparent from existing data. However, it has been shown that fuel-bound nitrogen is readily converted (50 to 100 percent) to NO_x in both stationary and aircraft turbine combustors (Ref 20.33 - 20.36). Should aircraft fuel-bound nitrogen levels be increased in the future because of changing fuel requirements, fuel-bound nitrogen could become a significant problem (See Section 20.4.2).

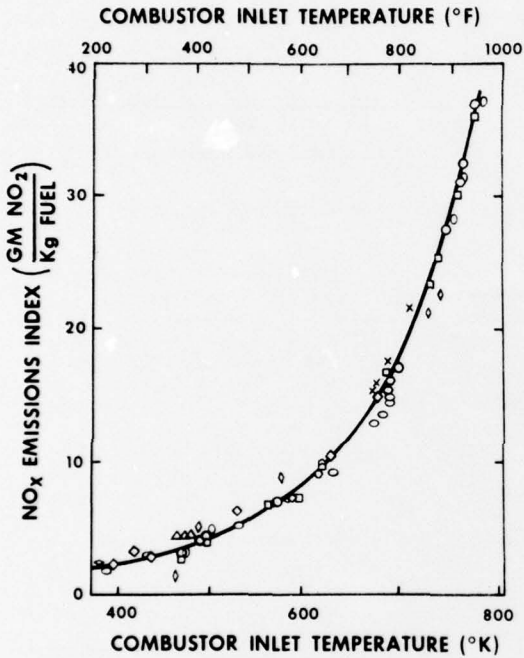

Figure 20.4.2 Correlation of Current Engine NO_x Emissions with Combustor Inlet Temperature

The dependence of NO_x emission on combustor inlet temperature is reflected in a strong relationship with cycle pressure ratio at sea level conditions and with cycle pressure ratio and flight Mach number at altitude. Figure 20.4.3 illustrates the relationship between NO_x emission and cycle pressure ratio at sea level static conditions. Figure 20.4.4 presents the dependence of NO_x emission on cycle pressure ratio and flight Mach number. Since the optimum pressure ratio for each flight Mach number changes with calendar time as technology developments allow higher temperature operation, a band of logical operating conditions at the 1970 technology level has been indicated in Figure 20.4.4.

Smoke formation is favored by high fuel-air ratio and pressure. Upon injection into the combustor, the heavy molecular weight fuel molecules are subjected to intense heating and molecular breakdown or pyrolysis occurs. If this process occurs in the absence of sufficient oxygen (i.e., high fuel-air ratio), the small

hydrogen fragments can form carbon particulates which eventually result in smoke emission. The process by which carbon particulates are formed is known to be very pressure sensitive. Combustor designers have been successful in tailoring the burner to avoid fuel-rich zones, thus substantially reducing smoke levels. The current generation of engines (JT9D, CF6, RB211) has nearly invisible exhaust trails. The techniques resulting in these improvements will be highlighted in a subsequent subsection.

b. Afterburning Engines: Relatively little information is available regarding emission during afterburner operation. General trends in existing data indicate possible significant levels of CO and HC at the exhaust plane, especially at the lower afterburner power settings (Ref 20.37 - 20.41). However, Lyon (Ref 20.41) has confirmed that, at sea level, much of the CO and HC is chemically reacted to CO_2 and H_2O in the exhaust plume downstream of the exhaust plane. These downstream reactions have been shown to consume up to 93% of the pollutants present at the exhaust plane. The extent of these plume reactions at altitude is uncertain. Although lower ambient pressures tend to reduce chemical reaction rates, reduced viscous mixing and the exhaust plume shock field tend to increase exhaust gas time at high temperature and thus reduce the final emission of incomplete combustion products.

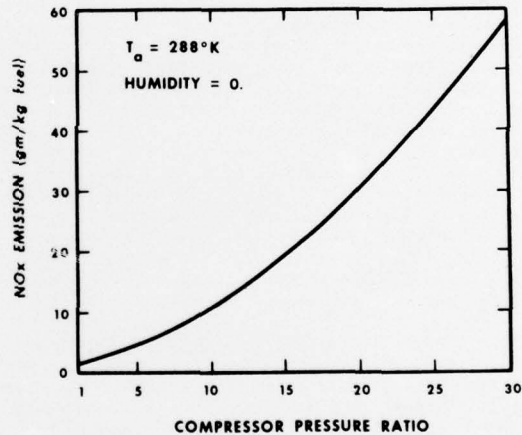

Figure 20.4.3 Dependence of Sea Level Standard Day NO_x Emissions on Compressor Pressure Ratio of Current Engines

NO_x emission during afterburner operation expressed on an EI basis is lower than during non-afterburning operation because of reduced peak flame temperatures in the afterburner. The value, under sea-level conditions, is approximately 2 - 5 g/kg fuel (Ref 20.42). At altitude, it is expected that the emission index would be 3.0 or less. Duct burners are expected to have an NO_x EI of about 5.0 during altitude operation (Ref 20.42). While the total NO_x emission is not significantly influenced by plume^x reactions, there is speculation that conversion of NO to NO_2 occurs both within the afterburner and in the plume (Ref 20.41).

Smoke or carbon particle emissions are reduced by the use of an afterburner (Ref 20.41). Conditions within an afterburner are not conducive to carbon particle formation, but soot from the

main burner may be oxidized in the afterburner, thus resulting in a net reduction.

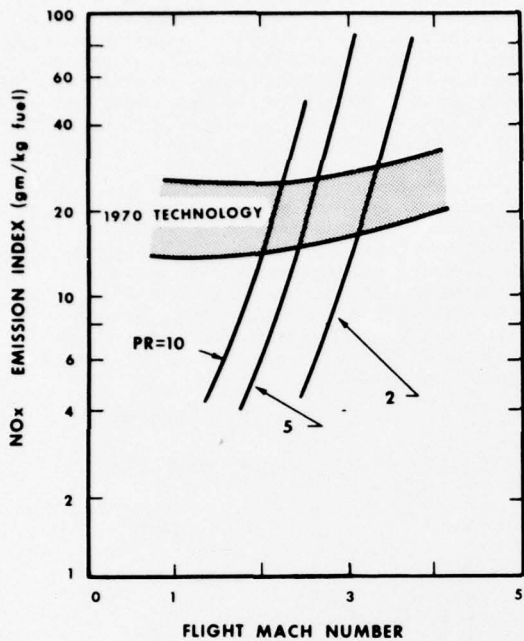

Figure 20.4.4 Dependence of NO_x Emission on Flight Mach Number

20.4.1.4 Minimization of Emissions:

Previous discussions of emissions levels concerned existing engines. Control technology may reduce emissions from these baseline levels by varying degrees. The fundamental means by which emissions may be reduced are discussed in this section.

a. Smoke Emission: Technology to control smoke emission is well in hand and it would appear that future engines will continue to be capable of satisfying the future requirement of exhaust invisibility. The main design approach used is to reduce the primary zone equivalence ratio to a level where particulate formation will be minimized. Thorough mixing must be accomplished to prevent fuel-rich pockets which would otherwise preserve the smoke problem, even with overall lean primary zone operation. This must be done while maintaining other combustor performance characteristics. Airflow modification to allow leaner operation and airblast fuel atomization and mixing have been employed to accomplish these objectives. However, ignition and flame stabilization are the most sensitive parameters affected by leaning the primary zone and must be closely observed during the development of low smoke combustors.

b. HC and CO Emission: To prevent smoke formation, the primary zone equivalence ratio of conventional combustors at higher power operation must not be much above stoichiometric--this leads to much lower than stoichiometric operation at idle where overall fuel-air ratios are roughly one-third of the full-power value. Inefficient idle operation may be improved by numerous methods. The objectives in each technique are to provide a near-stoichiometric zone for maximum consumption of hydrocarbons

while allowing sufficient time within the intermediate zone (where $\phi = 0.5$) to allow for CO consumption.

To achieve increased localized fuel-air ratio, dual orifice nozzles are frequently applied to modify fuel spray patterns at idle. Attempts to improve fuel atomization also provide decreased idle HC and CO through more rapid vaporization (Ref 20.43). Greater local fuel-air ratios at idle can also be achieved by increased compressor air bleed or fuel nozzle sectoring. In this latter case, a limited number of nozzles are fueled at a greater fuel flow rate. Schemes where two 90° or one 180° sector is fueled have shown significant HC and CO reduction (Ref 20.44).

Advanced approaches make use of staged combustion. The first stage, being the only one fueled at idle, is designed for peak idle combustion efficiency. The second stage is only utilized at higher power conditions. This main combustion zone is designed with a primary motivation toward NO_x reduction. Significant HC and CO reductions have been demonstrated using the staged approach (Ref 20.45 - 20.50). An example of such a design is shown in Figure 20.4.5.

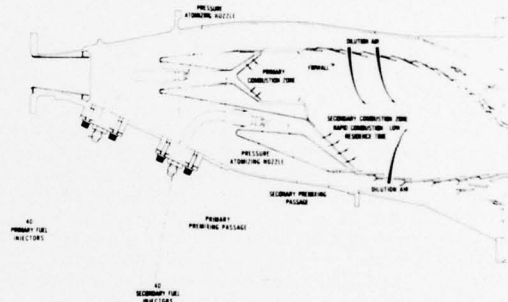

Figure 20.4.5 Staged Premix Combustor. JT9D Engine

c. NO_x Emission: NO_x has been the most difficult aircraft engine pollutant to reduce in an acceptable manner. Currently available technology for reducing NO_x emissions consists of two techniques discussed briefly below.

Water injection into the combustor primary zone has been found to reduce oxide-of-nitrogen emissions significantly (up to 80%). Peak flame temperatures are substantially reduced by the water injection resulting in a sharp reduction in NO_x formation rate. In a number of cases where this technique has been attempted, however, CO emissions have increased, although not prohibitively. Figure 20.4.6 shows the relation between water injection rate and NO_x reduction (Ref 20.51). This method is not feasible for reducing cruise NO_x because the water flow required to attain significant abatement is of the order of the fuel-flow rate. In addition, there are difficulties with engine durability, performance, logistics, and economic problems associated with the cost of providing necessary demineralized water. Consequently, these factors have caused this technique to receive negative evaluation as an approach toward universal reduction of ground level NO_x .

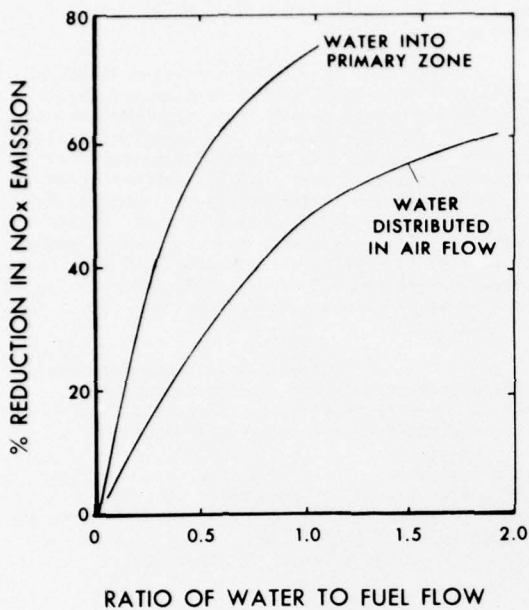

Figure 20.4.6 Ideal Effectiveness of Water Injection for NO_x Control

A second method that has been used to reduce NO_x emissions involves airblast atomization and rapid mixing of the fuel with the primary-zone air flow. Much literature has been generated on this technique (notably the NASA swirl-can technology, References 20.52 - 20.54). One engine, the F101, used in the B-1 aircraft, employs this principle. In the case of the F101, the overall combustor length was shortened from typical designs because of improved fuel-air mixture preparation. As a result, this method reduced both ground-level and altitude NO_x emissions. Reductions of approximately 50 percent below the uncontrolled case (Figure 20.4.3) have been measured.

Advanced approaches to the reduction of NO_x can be divided into two levels of sophistication. The first level involves staged combustors like that shown in Figure 20.4.5. In this case, fuel is injected upstream of the main combustion zone, which may be stabilized by a system of struts (or flameholders). Residence time in the premixing zone is short (i.e., high velocity and short length) because of the possibility of pre-ignition or flame propagation upstream. It is known that these designs provide a fuel-air mixture far from ideal premix/prevaporization. In fact, the turbulence and nonuniformity characteristics of this system are probably not unlike those of conventional combustors. However, since the mixture ratio is only 0.6 stoichiometric, reduced NO_x levels result. Reductions of up to a factor of $\times 3$ have been achieved (Ref 20.45 - 20.50).

Testing the advanced techniques of the second level--combustors utilizing pre-mixing and prevaporization operating at equivalence ratios below 0.6--has aimed at ultra low NO_x emission levels. These fundamental studies have been motivated by efforts to reduce automotive gas

turbine emissions, as well as those to reduce stratospheric aircraft gas turbine emissions--the pressure ratio of the automotive engine is low with the absolute pressure level being similar to the aircraft case at altitude. Nevertheless, inlet temperatures are high in the automotive case because of the use of regenerators. Ferri (Ref 20.55), Verkamp, et al. (Ref 20.56), Anderson (Ref 20.57), Wade, et al. (Ref 20.58), Azelborn, et al. (Ref 20.59), Collman, et al. (Ref 20.60), and Roberts, et al. (Ref 20.61) have published results that indicate that levels below 1 g NO_x/kg fuel can be approached. Anderson's work is particularly thorough in discussing fundamental tradeoffs with combustion efficiency. His results are shown in Figure 20.4.7. Good agreement with analytical model results indicates that useful conclusions may be drawn from the model predictions. These predictions all indicate that an "emissions floor" of approximately 0.3 to 0.5 g/kg fuel is the limit of NO_x emissions reduction.

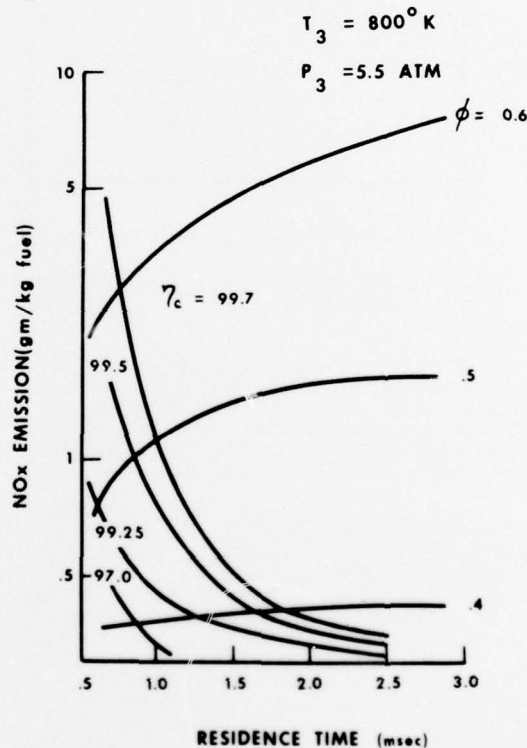

Figure 20.4.7 Effect of Residence Time and ϕ on Nitrogen Oxide Emissions

A number of difficulties associated with the combustion of premixed/prevaporized lean mixtures can be alleviated by the use of a solid catalyst in the reaction zone. Recent developments to construct catalytic converters to eliminate automotive CO and HC emissions have increased the temperature range within which such a device might operate. Test results have now been published that apply the concept of catalytic combustion to aircraft gas turbine combustors (Ref 20.62 - 20.69). The presence of the catalyst in the combustion region provides stability at lower equivalence ratios than possible in gas-phase combustion. This is due to the combined effect of

heterogeneous chemical reactions and the thermal inertia of the solid mass within the combustion zone. The thermal inertia of the catalytic combustor system has been calculated to be more than two orders of magnitude greater than in the gas-phase combustion system. NO_x reductions up to factors of 100 seem to be possible using the catalytic combustor approach.

20.4.2 Future Jet Fuels

Between 1973 and 1976, the cost and availability of aircraft jet fuels have drastically changed. Per-gallon jet fuel costs have more than tripled for both commercial and military consumers. In addition, fuel procurement actions have encountered difficulties in obtaining desired quantities of fuel, even though significantly reduced from 1972 consumption levels. These developments have encouraged initial examinations of the feasibility of producing jet fuels from non-petroleum resources (Ref 20.70 - 20.72).

Although economics and supply are primarily responsible for this recent interest in new fuel sources, projections of available world-wide petroleum resources also indicate the necessity for seeking new means of obtaining jet fuel. Regardless of current problems, the dependence on petroleum as the primary source of jet fuel can be expected to cease sometime within the next half century (Ref 20.73).

If the general nature of future aircraft (size, weight, flight speed, etc.) is to remain similar to today's designs, liquid hydrocarbons can be expected to continue as the primary propulsion fuel. Liquefied hydrogen and methane have been extensively studied as alternatives but seem to be practical only for very large aircraft. The basic non-petroleum resources from which future liquid hydrocarbon fuels might be produced are numerous. They range from the more familiar energy sources of coal, oil shale, and tar sands to possible future organic materials derived from energy farming. Some of the basic synthetic crudes, especially those produced from coal, will be appreciably different than petroleum crude. Reduced fuel hydrogen content would be anticipated in jet fuels produced from these alternate sources.

Because of the global nature of aircraft operations, jet fuels of the future are likely to be produced from a combination of these basic sources. Production of fuels from blends of synthetic crudes and natural crudes may also be expected. In light of the wide variations in materials from which world-wide jet fuel production can draw, it is anticipated that economics will dictate the acceptance of future fuels with properties other than those of currently used JP-4, JP-5, and Jet A. Much additional technical information will be required to identify the fuel characteristics which meet the following objectives:

- a) Allow usage of key world-wide resources to assure availability.
- b) Minimize the total cost of aircraft system operation.
- c) Avoid major sacrifice of engine performance, flight safety, or environmental impact.

A complex program is necessary to establish the information base from which future fuel specifica-

tions can be derived. Figure 20.4.8 depicts the overall nature of the required effort. Fuel processing technology will naturally be of primary importance to per gallon fuel costs. The impact of reduced levels of refining (lower fuel costs) on all aircraft system components must be determined. These include fuel system (pumps, filters, heat exchangers, seals, etc.), and airframe (fuel tank size and design, impact on range, etc.) considerations as well as main burner and afterburner impacts. In addition, handling difficulties (fuel toxicity) and environmental impact (exhaust emissions) require evaluation. The overall program must be integrated by a system optimization study intended to identify the best solution to the stated objective.

20.4.2.1 Fuel Effects on Combustion Systems: Future fuels may affect combustion system/engine performance through changes in hydrogen content, volatility, viscosity, olefin content, fuel nitrogen, sulfur, and trace metal content.

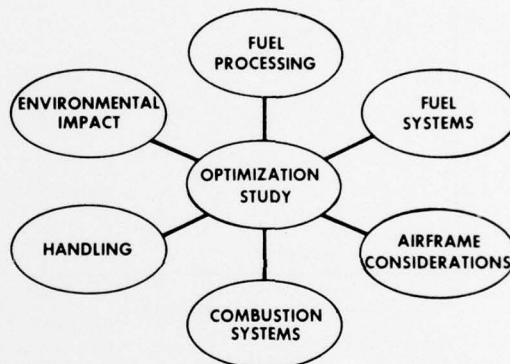

Figure 20.4.8 Overall Scheme for Alternate Jet Fuel Development Program

Fuel hydrogen content is the most important parameter anticipated to change significantly with the use of alternate fuels. In particular, fuels produced from coal would be expected to have significantly reduced hydrogen content. In most cases, reduction in fuel hydrogen content would be due to increased concentrations of aromatic-type hydrocarbons in the fuel. These may be either single ring or polycyclic in structure. Experience has shown that decreased hydrogen content significantly influences the fuel pyrolysis process in a manner which results in increased rates of carbon particle formation. In addition to increased smoke emission, the particulates are responsible for formation of a luminous flame where black-body radiation from the particles is a predominant mode of heat transfer.

Significantly increased radiative loading on combustor liners can result from decreased fuel hydrogen content. Increases in liner temperature translate into decreases in hardware life and durability. Figure 20.4.9 illustrates the sensitivity of combustor liner temperature to hydrogen content. The following non-dimensional temperature parameter is used to correlate these data (Ref 20.34, 20.74 - 20.77) representative of older engine designs.

$$\frac{T_L - T_{LO}}{T_{LO} - T_3}$$

The numerator of this expression represents the increase in combustor liner temperature, T_L , over that obtained using the baseline fuel (14.5% hydrogen JP-4), T_{LO} . This is normalized by the difference between T_{LO} and combustor inlet temperature, T_3 . It was found that data obtained using different combustors could be correlated using this parameter. It should also be noted that the parameter is representative of the fractional increase (over the baseline fuel) in heat transfer to the combustor liner.

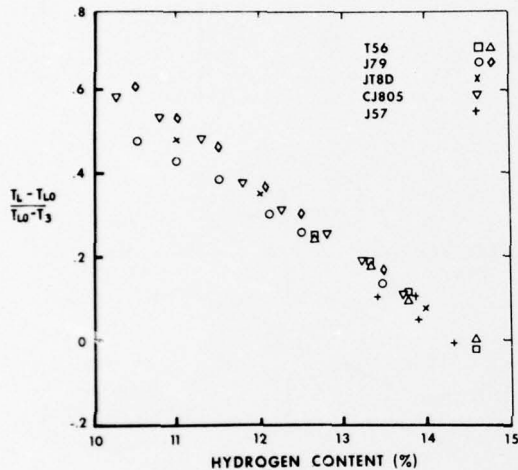

Figure 20.4.9 Liner Temperature Correlation for Many Combustor Types

Because combustor design differences play an important part in determining engine smoke characteristics, differences in emission are not correlatable in the same manner as combustor liner temperature. However, results obtained using a T56 single combustor rig (Ref 20.34) are illustrative of the important trends (see Figure 20.4.10). Significantly increased smoke emission was determined with decreased hydrogen content for each condition tested. Trends between smoke emission and hydrogen content are similar for each combustion condition. Increased absolute smoke emission between the 394°K and 644°K combustor inlet temperature conditions is attributable to increased pressure and fuel-air ratio. Although a further small increase might be expected for the 756°K condition because of higher pressure, the lower fuel-air ratio required to maintain the 1200°K exhaust temperature results in a lower absolute smoke emission.

Volatility affects the rate at which liquid fuel introduced into the combustor can vaporize. Since important heat release processes do not occur until gas phase reactions take place, reduction of volatility shortens the time for chemical reaction within the combustion system. In the aircraft engine this can result in difficulty in ground or altitude ignition capability, reduced combustor stability, increased emissions of carbon monoxide (CO) and hydrocarbons (HC), and the associated loss in combustion efficiency. Moreover,

carbon particle formation is aided by the formation and maintenance of fuel-rich pockets in the hot combustion zone. Low volatility allows rich pockets to persist because of the reduced vaporization rate. Again, increased particulates can cause additional radiative loading to combustor liners and more substantial smoke emissions.

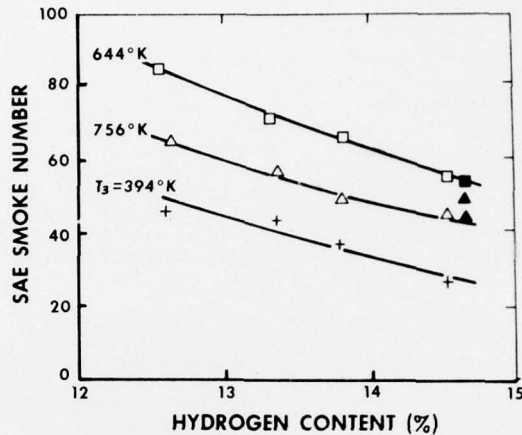

Figure 20.4.10 Smoke Emission Dependence on Hydrogen Content

The desired formation of a finely dispersed spray of small fuel droplets is adversely affected by viscosity. Consequently, the shortened time for gas phase combustion reactions and prolonging of fuel-rich pockets experienced with low volatility can also occur with increased viscosity. The ignition, stability, emissions, and smoke problems previously mentioned also increase for higher viscosity fuels.

Olefin content is known to influence fuel thermal stability. Potential problems resulting from reduced thermal stability include fouling of oil-fuel heat exchangers and filters, and plugging of fuel metering valves and nozzles. No negative effect of fuel olefin content on gas phase combustion processes would be expected.

The effect of increased fuel-bound nitrogen is evaluated by determining the additional NO_x emission occurring when nitrogen is present in the fuel and calculating the percent of fuel nitrogen conversion to NO_x necessary to cause this increase. The baseline petroleum fuels used in this study had near zero (<10 ppmw) fuel-bound nitrogen. Results presented in Figure 20.4.11 indicate the importance of two variables. First, as combustor inlet temperature is increased, conversion is reduced. Secondly, as fuel-bound nitrogen concentrations are increased, conversion decreases. This second trend is consistent with available results for oil shale JP-4 which had less than .08% nitrogen. Synfuel results are shown as a band in Figure 20.4.11 because of difficulties in accurately measuring small NO_x increases.

Both sulfur and trace metals are at very low concentrations in current jet fuels. Sulfur is typically less than 0.1% because the

petroleum fraction used for jet fuel production is nearly void of sulfur-containing compounds. Although syncrudes from coal or oil shale would be expected to contain higher sulfur levels, it is not likely that the current specification limit of 0.4% would be exceeded with the processed jet fuel. Because of the way in which future jet fuels are expected to be produced, trace metals are also expected to continue to be present at low concentrations (less than 1 ppmw). Should higher levels appear possible, the serious consequences (deleterious effects on turbine blades) would justify additional expense for removal.

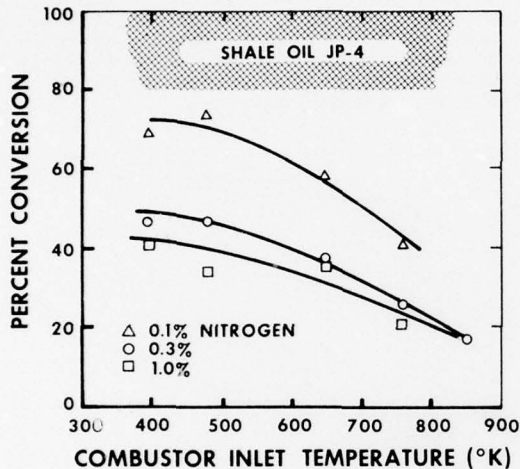

Figure 20.4.11 Fuel-Bound Nitrogen Conversion to NO_x in an Aircraft Gas Turbine Combustor

20.4.2.2 Combustion System Design Impact:

Although in the early stages of assessment, it appears certain that future combustion system designs will be significantly influenced by the changing character of fuel properties as alternate energy sources are tapped. Designs that accommodate lower hydrogen content fuels with good combustor liner durability and low smoke emission while maintaining the customary level of combustion system performance must be developed.

Lean primary zone combustion systems, which are much less sensitive to fuel hydrogen content, will comprise a major approach to utilizing new fuels. Low smoke combustor designs have been shown to be much less sensitive to fuel hydrogen content variations. Figure 20.4.12 compares the correlation for older designs (Figure 20.4.9) with results for a newer, smokeless combustor design, the CF6 (Ref 20.78). Current research on staged combustion systems (See 20.4.1.4) will further contribute toward achieving the goal of leaner burning while maintaining desired system performance. Some of these designs have demonstrated very low sensitivity to fuel type (Ref 20.78). These extremely important developments provide encouragement that future fuels of lower hydrogen content can be accommodated while maintaining acceptable emissions characteristics.

20.4.3 Design and Performance Advancements

The following subsection briefly addresses three new design concepts currently under consider-

ation intended to address future turbopropulsion performance requirements. The High Mach Combustor (HMC) is an advanced system design concept for substantially increased performance relative to contemporary systems. The Vortex Controlled Diffuser (VCD) is an improved, low-loss boundary-layer bleed diffuser which supports the needs of both current and future combustion systems. The shingle liner is an advanced concept combining new design features for both improved structural and thermal durability.

20.4.3.1 High Mach Combustor (HMC):

The HMC is an advanced combustor design concept required to meet the needs of the High Thru-Flow Propulsion System (HTFPS). The HTFPS is an advanced technology engine designed for high performance, light-weight and low cost. It will utilize a variable-geometry compressor, a high entrance Mach number, high temperature rise combustor and a variable-geometry turbine and exhaust nozzle. As a result, the combustor must be capable of accepting entrance flow fields at Mach numbers nearly twice that of contemporary systems but at virtually the same pressure loss levels. Two approaches may be taken to meet these technology requirements: (1) slow the combustor entrance Mach number to conventional levels by an advanced diffusion system (bleed, dump, or staged diffuser) and utilize contemporary combustor technology; or (2) design the combustor to accept the high velocity flow field by use of swirl combustion techniques. A cross-section of a bleed HMC is illustrated in Figure 20.4.13 while a high velocity swirl burning concept is illustrated in Figure 20.4.14.

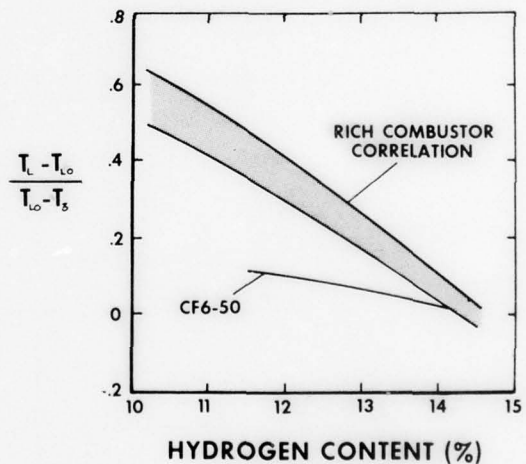

Figure 20.4.12 Effect of Lean Operation on Combustor Fuel Sensitivity

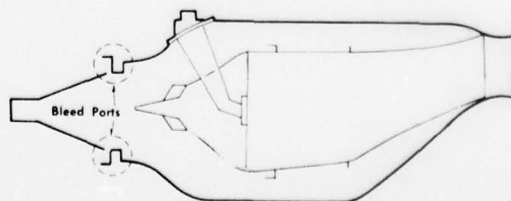

Figure 20.4.13 HMC with Advanced Bleed Diffuser

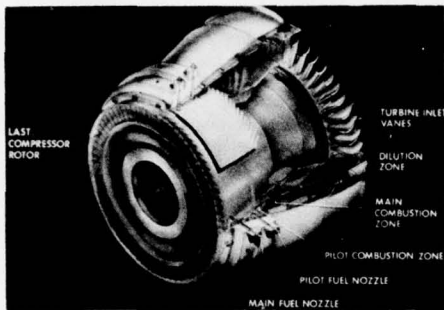

Figure 20.4.14 Swirl Burning HMC

20.4.3.2 Vortex Controlled Diffuser (VCD): The VCD is a compact boundary-layer-bleed combustor inlet diffuser designed to effectively diffuse both conventional and high Mach number flow fields while providing good pressure loss and flow stability in a very short length (relative to contemporary diffusion systems). The VCD was initially investigated at Cranfield Institute of Technology by Adkins (Ref 20.79). The basic VCD geometry and nomenclature are defined in Figure 20.4.15. Inner and outer VCD bleeds flow from the primary duct exit providing high pressure recovery and low pressure loss. The VCD advantages are principally (1) short diffuser length, (2) high pressure recovery, (3) design simplicity and (4) stable flow provided by the vortex retaining fences. This concept offers considerable promise and is expected to find its way into a wide range of future propulsion system applications. Extended development of the VCD has been sponsored by the Air Force and conducted at the Detroit Diesel Allison Division of GMC.

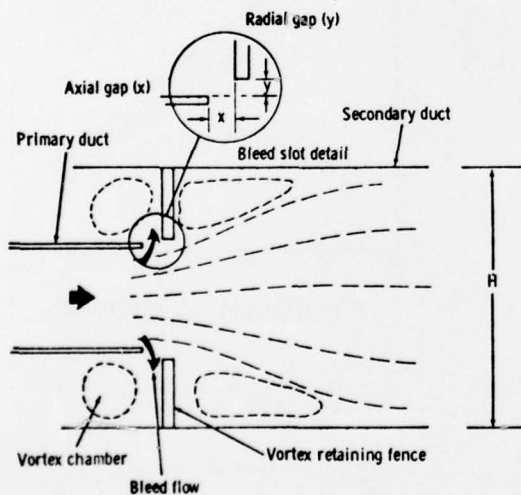

Figure 20.4.15 Vortex Controlled Diffuser

20.4.3.3 Shingle Liner: The Shingle Liner design concept is an advanced combustor cooling technique featuring a new innovation wherein the thermal and mechanical stress loads of the combustor are isolated and controlled by independent means.

The liner is basically an impingement cooled segmented design as illustrated in Figure 20.4.16. The outer shell serves as the structural or load carrying portion of the combustion system and provides impingement cooling for the inner segments or shingles. As a result, the shingles provide an effective thermal barrier, protecting the highly-stressed outer shell. The shingle liner is particularly well suited to high temperature rise combustor operation where cooling airflow is at a premium. Additionally, the shingle concept offers improved liner life due to its thermally relieved mechanical design aspect and the possibility of improved maintainability, as low-cost "throw-away" segments may be employed. The Shingle Liner development was sponsored by the Navy and conducted by the General Electric Company. It is presently being considered for both near-term and future propulsion system application.

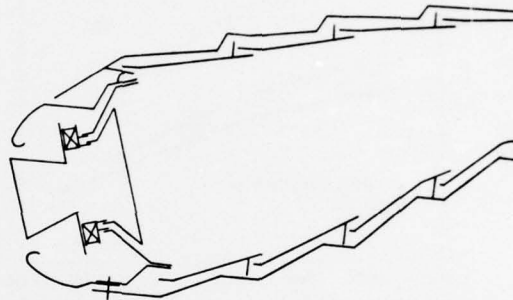

Figure 20.4.16 Shingle Liner Combustor

20.5 CONCLUSIONS

As discussed earlier, the turbine engine combustion system has undergone an evolutionary development process over the past forty years beginning with long, bulky, can-type combustors (i.e., the J33 shown in Figure 20.1.3) and progressing to the compact, high temperature rise annular combustors of today's newest turbopropulsion systems. In recent years, significant technological advancements have been realized in both combustion system design and performance. With respect to the important design parameters of combustion efficiency and stability, pressure loss, combustor size, and pattern factor, the annular combustors recently developed have provided substantial improvements. Further improvements in these parameters will be required, however, if propulsion system demands of the future are to be met.

In the vital area of durability, improvements in liner design and cooling have added substantially to the maintainability and durability aspects of the combustor at a time when system operating pressures and temperatures are on the rise. Figure 20.5.1 illustrates the technological improvements realized in the 10 - 15 years since annular combustors were introduced. For example, the continued drive for reduced cost, improved fuel economy and design compactness and simplicity has led to the compact, high temperature combustor of the F101 engine (developed for the B-1 Bomber) illustrated in Figure 20.5.2. This combustor is a low pressure loss (5.1%), high heat release (7.5×10^6 BTU/hr/atm/ft²) design

employing an improved low pressure fuel injection system, a machined-ring high durability liner and a simple, cast, low-loss inlet dump diffuser. Relative to other contemporary combustion systems, the F101 is the most advanced annular design developed to date and introduces a new family of compact, high temperature systems for fighter, bomber, and transport applications.

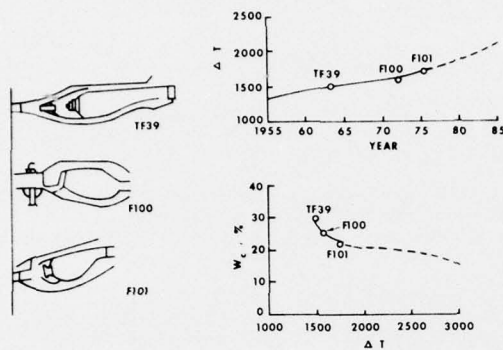

Figure 20.5.1 Annular Combustor Development Trends

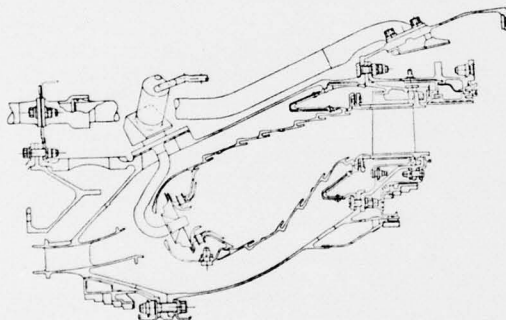

Figure 20.5.2 F101 Annular Combustor

Future aircraft propulsion requirements call for primary combustors capable of: (1) accepting greater variations in compressor discharge pressure, temperature and airflow, (2) producing heat release rates and temperature rise which will ultimately approach stoichiometric levels, and (3) providing high operational reliability and improved component durability, maintainability, and repairability. In addition, the new requirements discussed in Section 20.4--exhaust emissions and fuel flexibility--must be addressed.

It is only possible to speculate on new concepts which might be employed in the next quarter century in aero-propulsion combustion. Nevertheless, such an effort is worthwhile as the reader may gain an appreciation for the wide range of opportunity and flexibility which remains available to the combustion system designer. Two new concepts, catalytic combustion and photochemically-assisted combustion, will be highlighted below.

Catalytic combustion involves the use of a heterogeneous catalyst within the combustion zone to increase the energy release rate (Ref 20.62 - 20.69). Fuel and air are premixed at low equivalence ratios, often below the lean flammability limit, and passed through a catalytically-coated, ceramic honeycomb structure. Due to the combined effect of heterogeneous chemical reactions and the thermal inertia of the solid structure, this concept can be utilized to achieve stable, efficient combustion outside the normal flammability limits of gas-phase systems (Ref 20.62 - 20.69). Typical experimental results are shown in Figure 20.5.3. The benefits of lean combustion (low radiative emission, decreased tendency for turbine inlet temperature non-uniformities, reduced smoke and NO_x formation) provide significant potential payoff^x. Applications in both main burners and afterburners are likely. The promising concept of a porous flameholder with low pressure drop is under investigation. Such a device would provide a means of stabilizing combustion flows that reach final flame temperatures in excess of flameholder material limitations.

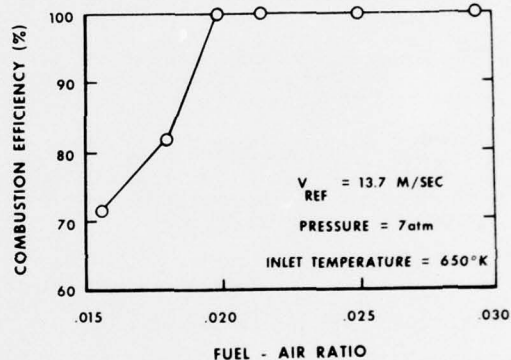

Figure 20.5.3 Catalytic Combustor Efficiency

A second new concept utilizes either ultraviolet light sources or plasmas to stabilize or promote combustion processes. Recent studies have confirmed the possibility of photochemical ignition where a pulse of ultraviolet light (from an arc discharge) is used to dissociate molecular oxygen and provide ignition at lower temperatures and with lower energy input than in the case of a spark ignition source (Ref 20.80, 20.81). Other investigations have confirmed the capability of plasma jets in supplying reactive species to stabilize and improve the efficiency of combustion flows (Ref 20.82). The payoff of these two concepts can be flame stabilization without flameholding devices--an "optical flameholder" with zero pressure drop. Such a device would further promote the feasibility of practical lean combustion.

While the example concepts described above are in their infancy and may not find eventual practical application in the turbo-propulsion field, they are illustrative of future combustion technology developments. As the combustor designer is confronted with the new requirements of the future, especially exhaust emissions and fuel flexibility, new concepts like these will play an important role in problem solution. Engineers in the aero-propulsion combustion community will certainly enjoy challenges with the possibility for imaginative

solutions as the next quarter century unfolds.

20.6 REFERENCES

- 20.1 Whittle, Sir Frank, Jet, The Story of a Pioneer, Frederick Muller Ltd, London, 1953.
- 20.2 Smith, I. E., Combustion in Advanced Gas Turbine Systems, Pergamon Press, New York, 1967.
- 20.3 Cornelius, W., and Agnew, W. G., Emissions From Continuous Combustion Systems, Plenum Press, New York, 1972.
- 20.4 Swithenbank, J., Combustion Fundamentals, Air Force Office of Scientific Research, Washington DC, February, 1970.
- 20.5 Propulsion Chemistry Division, Lewis Flight Propulsion Laboratory, "Basic Consideration in the Combustion of Hydrocarbon Fuels with Air", edited by H. C. Barnett and R. R. Hibbard, NACA Report 1300, 1957.
- 20.6 "The Design and Performance Analysis of Gas-Turbine Combustion Chambers," Vol I, Northern Research and Engineering Corporation, 1964.
- 20.7 Reneau, L. R., Johnston, J. P., and Kline, S. J., "Performance and Design of Straight Two-Dimensional Diffusers, Report PD-6, Thermosciences Division, Department of Mechanical Engineering, Stanford University, Stanford CA, 1964.
- 20.8 Rizkalla, A. A., and Lefebvre, A. H., "The Influence of Air and Liquid Properties on Airblast Atomization," Journal of Fluids Engineering, Vol 97, Series 1, Number 3, PP 316-320, September 1975.
- 20.9 Rizkalla, A. A., and Lefebvre, A. H., "Influence of Liquid Droplets on Airblast Atomizer Spray Characteristics," Journal of Engineering for Power, Series A of ASME Transactions, Volume 97, April 1975.
- 20.10 Lefebvre, A. H., and Miller, D., "The Development of Airblast Atomizer for Gas Turbine Application, College of Aero. Rep., Aero No. 193, 1967.
- 20.11 Lefebvre, A. H., Theoretical Aspects of Gas Turbine Combustion Performance, College of Aeronautics, Cranfield, Co. A., Note Aero No 163, August 1966.
- 20.12 Herbert, J. D., "Theoretical Analysis of Reaction Rate Controlled Systems - Part I", AGARD Combustion Research and Reviews, Chapter 6, 1957.
- 20.13 Swithenbank, J., Poll, I., Wright, D. D., and Vincent M. W., "Combustion Design Fundamentals," 11th Symposium (International) on Combustion, The Combustion Institute, Pittsburgh, PA, August 1972.
- 20.14 Spaulding, D. B., "Mathematical Models of Continuous Combustion," in Emissions From Continuous Combustion Systems, Edited by W. Correlius and W. G. Agnew, Plenum Publishing Corporation, New York, 1972.
- 20.15 Gosman, A. O., Pun, W. M., Runchal, A. K., Spaulding, D. B., and Wolfshstein, M., Heat and Mass Transfer in Recirculating Flows, Academic Press, New York, New York, 1969.
- 20.16 Mosier, S. A., and Roberts, R. "Low Lower Turbopropulsion Combustor Exhaust Emissions," Vol I, II and III, Air Force Aero-Propulsion Laboratory Report AFAPL-TR-73-36, June 1973.
- 20.17 Anasoulis, R. F., McDonald, H., and Buggelin, R. C., "Development of a Combustor Flow Analysis," Vol I and II, Air Force Aero-Propulsion Laboratory Report AFAPL-TR-73-98, January 1974.
- 20.18 Clean Air Act Amendments of 1970, 40 USC 1857 as amended by PL 91-604.
- 20.19 U.S. Environmental Protection Agency, "Aircraft Emissions: Impact on Air Quality and Feasibility of Control," February 1972.
- 20.20 U.S. Environmental Protection Agency "Control of Air Pollution from Aircraft and Aircraft Engines," Federal Register, Vol 38, No 136, 17 July 1973.
- 20.21 Grobecker, A. J., Coroniti, S. C., and Cannon, R. H. Jr., "Report of Findings--Executive Summary, The Effects of Stratospheric Pollution by Aircraft," Department of Transportation Climatic Impact Assessment Program, Washington DC, December, 1974.
- 20.22 Society of Automotive Engineers, "Procedure for the Continuous Sampling and Measurement of Gaseous Emissions From Aircraft Turbine Engines," Aerospace Recommended Practice 1256, New York, 1971.
- 20.23 Society of Automotive Engineers, "Aircraft Gas Turbine Engine Exhaust Smoke Measurements," Aerospace Recommended Practice 1179, New York, 1970.
- 20.24 Champagne, D. L., "Standard Measurement of Aircraft Gas Turbine Exhaust Smoke," ASME Paper No. 71-GT-88, Paper presented at the Gas Turbine Conference and Products Show, Houston, TX, March-April 1971.
- 20.25 Bogdan, L., and McAdams, H. T., "Analysis of Aircraft Exhaust Emissions Measurements," Rep. No. NA-5007-K-1, Cornell Aeronautical Labs, Buffalo NY, 1971.
- 20.26 Groth, R. H., and Robertson, D. J., "Reactive and Unreactive Hydrocarbon Emissions from Gas Turbine Engines," APCA Paper No. 74-89, Paper presented at the 67th Meeting of the Air Pollution Control Association, Denver, CO, June 1974.
- 20.27 Kendall, D. A., and Levins, P. L., "Odor Intensity and Characterization of Jet Exhaust and Chemical Analytical Measurements," NASA CR-12-159, 1973.
- 20.28 Butze, H. F., and Kendall, D. A., "Odor Intensity and Characterization Studies of Exhaust from a Turbojet Engine Combustor," AIAA Paper No. 73-1278, Paper presented at the AIAA/SAE 9th Propulsion Conference, Las Vegas, NV, November 1973.
- 20.29 Katzman, H., and Libby, W. F., "Hydrocarbon Emissions from Jet Engines Operated at Simulated High-Altitude Flight Conditions," Paper presented at the AIAA/AMS Second International Conference on the Environmental Impact of Aerospace Operations in the High Atmosphere, San Diego, CA, July 1974.

- 20.30 Giovanni, D. V., and Hilt, M. R., "Particulate Matter Emission Measurements from Stationary Gas Turbines," ASME Paper No. 73-PWR-17, September 1973.
- 20.31 Slusher, G. R., "Sulfur Oxide Measurement in Aircraft Turbine Engine Exhaust," FAA-RD-75-101, September 1975.
- 20.32 Lipfert, F. W., "Correlations of Gas Turbine Emissions Data," ASME Paper 73-GT-60, Paper presented at the 17th International Gas Turbine Conference and Products Show, San Francisco, CA, March 1973.
- 20.33 Blazowski, W. S., Fahrenbruck, F. S., and Tackett, L. P., "Combustion Characteristics of Oil Shale Derived Jet Fuels," Paper 75-13, presented at the 1975 WSS/CI Fall Technical Meeting, Palo Alto, CA, October 20-21, 1975.
- 20.34 Blazowski, W. S., "Combustion Considerations for Future Jet Fuels," 16th International Symposium on Combustion, the Combustion Institute, Pittsburgh, PA, 1976.
- 20.35 Butze, H. F., and Ehlers, R. C., "Effect of Fuel Properties on Performance of a Single Aircraft Turbojet Combustor," NASA-TM-X-71789, Presented at the 1975 WSS/CI Fall Technical Meeting, Palo Alto, CA, October 1975.
- 20.36 Wilkes, C. A., and Johnson, R. H., "Fuel Property Effects on Gas Turbine Emissions Control," Paper presented at the ASME Joint Power Conference, Miami, FL, September 1974.
- 20.37 Lazalier, G. R., and Gearhart, J. W., "Measurement of Pollution Emissions from an Afterburning Turbojet Engine at Ground Level, Part 2, Gaseous Emissions," AEDC-TR-72-70, Arnold Engineering Development Center, Tullahoma, TN, 1972.
- 20.38 Palcza, J. L., "Study of Altitude and Mach Number Effects on Exhaust Gas Emissions of an Afterburning Turbofan Engine," Rep No FAA-RD-72-31, Federal Aviation Administration, 1971.
- 20.39 German, R. C., High, J. D., and Robinson, C. E., "Measurement of Exhaust Emissions from a J85-GE-5B Engine at Simulated High-Altitude, Supersonic, Free-Stream Flight Conditions," AEDC-TR-73-103, Arnold Engineering Development Center, Tullahoma, TN 1973.
- 20.40 Diehl, L. A., "Measurement of Gaseous Emissions from an Afterburning Turbojet Engine at Simulated Altitude Conditions," NASA-TM-X-2726, 1973.
- 20.41 Lyon, T. F., Colley, W. C., Kenworthy, M. J., and Bahr, D. W., "Development of Emissions Measurement Techniques for Afterburning Turbine Engines," AFAPL-TR-75-52, October 1975.
- 20.42 Grobman, J., and Ingebo, R. D., "Forecast of Jet Engine Exhaust Emissions of High Altitude Commercial Aircraft Projected to 1990", In CIAP Monograph 2, Propulsion Effluents in the Stratosphere, DOT-TST-75-52, September 1975.
- 20.43 Norgren, C. T., and Ingebo, R. D., "Effect of Fuel Vapor Concentrations on Combustor Emissions and Performance," NASA-TM-X-2800, 1973.
- 20.44 Bahr, D. W., "Control and Reduction of Aircraft Turbine Engine Exhaust Emissions," in Emissions from Continuous Combustion Systems, pp 345-373, Plenum, New York, 1972.
- 20.45 Mularz, E., "Results of the Pollution Reduction Technology Program for Turboprop Engines," AIAA Paper 76-760, July 1976.
- 20.46 Roberts, R., Fiorentino, A., and Diehl, L., "Pollution Reduction Technology for Turbofan Engine Can Annular Combustors," AIAA Paper No. 76-761, July 1976.
- 20.47 Niedzwiecki, R., and Roberts, R., "Low Pollution Combustors for CTOL Engines - Experimental Clean Combustor Program (JT9D)," AIAA Paper No. 76-762, July 1976.
- 20.48 Niedzwiecki, R., and Gleason, C., "Low Pollution Combustor for CTOL Engines - Experimental Clean Combustor Program (CF6)," AIAA Paper No. 76-763, July 1976.
- 20.49 Roberts, P. B., White, D. J., Shekleton, J. R., and Butze, H. F., "Advanced Low NO_x Combustors for Aircraft Gas Turbines," AIAA Paper No. 76-764, July 1976.
- 20.50 Verdouw, A. J., "Evaluation of a Staged Fuel Combustor for Turboprop Engines," ASME Paper No. 76-WA/GT-5, July 1976.
- 20.51 Blazowski, W. S., and Henderson, R. E., "Aircraft Exhaust Pollution and Its Effects on the U.S. Air Force," AFAPL-TR-74-64, Air Force Aero-Propulsion Lab, Wright-Patterson Air Force Base, OH, 1974.
- 20.52 Niedzwiecki, R. W., and Jones, R. E., "Parametric Test Results of Swirl Can Combustor," NASA-TM-X-68247, June 1973.
- 20.53 Jones, R. E., "Advanced Technology for Reducing Aircraft Engine Pollution," NASA-TM-X-68256, November 1973.
- 20.54 Mularz, E. J., Wear, I. D., and Verbulecy, P. W., "Pollution Emissions from Single Swirl Can Combustor Modules at Parametric Test Conditions," NASA-TM-X-3167, January 1975.
- 20.55 Ferri, A., "Reduction of NO Formation by Premixing in Atmospheric Pollution by Aircraft Engines," AGARD Conf. Proc. No. 125, April 1973.
- 20.56 Verkamp, F. J., Verdouw, A. J., and Tomlinson, J. G., "Impact of Emissions Regulations on Future Gas Turbine Engine Combustors," AIAA Paper No. 73-1277, Paper presented at the AIAA/SAE 9th Propulsion Conference, Las Vegas, NV, November 1973.
- 20.57 Anderson, D. N., "Effects of Equivalence Ratio and Dwell Time on Exhaust Emissions from an Experimental Premixing Pre-vaporizing Burner," NASA-TM-X-71592, 1974.
- 20.58 Wade, W. R., Shen, P. I., Owens, C. W., and McLean, A. F., "Low Emissions Combustion for the Regenerative Gas Turbine, Part I - Theoretical and Design Considerations," ASME Paer No. 73-GT-11, December 1972.
- 20.59 Azelborn, N. A., Wade, W. R., Secord, J. R., McLean, A. F., "Low Emissions Combustion for the Regenerative Gas Turbine, Part II - Experimental Techniques, Results, and Assessment," ASME Paper No. 73-GT-12, Dec 1972.

- 20.60 Collman, J. S., Amann, C. A., Mathews, C. C., Stettler, R. J., and Verkamp, F. J., "The GT-255-- An Engine for Passenger Car Gas Turbine Research," SAE Paper No. 750167, February 1975.
- 20.61 Roberts, P. B., Shekleton, J. R., White, D. J., and Butze, H. F., "Advanced Low NO_x Combustor for Supersonic High-Altitude Aircraft Gas Turbines," ASME Paper No. 76-GT-12.
- 20.62 Blazowski, W. S., and Bresowar, G. E., "Preliminary Study of the Catalytic Combustor Concept as Applied to Aircraft Gas Turbines," AFAPL-TR-74-30, Air Force Aero-Propulsion Laboratory, Wright-Patterson AFB, Ohio, 1974.
- 20.63 Wampler, F. P., Clark, D. W., and Gaines, F. A., "Catalytic Combustion of C₂H₆ on Pt Coated Monolith," Western States Section of the Combustion Institute, Paper No. 74-36, October 1974.
- 20.64 Blazowski, W. S., and Walsh, D. E., "Catalytic Combustion: An Important Consideration for Future Applications," Comb. Sci. and Tech. Vol 10, pp 233-244, 1975.
- 20.65 Rosfjord, T. J., "Catalytic Combustors for Gas Turbine Engines," AIAA Paper 76-46, January 1976.
- 20.66 Anderson, D. N., Tacina, R. R., and Mroz, T. S., "Performance of a Catalytic Reactor at Simulated Gas Turbine Operating Conditions," NASA-TM-X-71747, 1975.
- 20.67 Pfeifferle, W. C., et al., "Catalytic Combustion: A New Process for Low Emissions Fuel Conversion," ASME Paper 75-WA/Pu-1, December 1975.
- 20.68 DeCorso, S. M., et al., "Catalysts for Gas Turbine Combustors - Experimental Test Results," ASME Paper 76-GT-4, March 1976.
- 20.69 Anderson, D. N., "Preliminary Results from Screening Tests of Commercial Catalysts with Potential Use in Gas Turbine Combustors. Part I. Furnace Studies of Catalyst Activity," NASA-TM-X-73410, and "Preliminary Results from Screening Tests of Commercial Catalysts with Potential Use in Gas Turbine Combustors, Part II. Combustion Test Rig Evaluation," NASA-TM-X-73412, May 1976.
- 20.70 Goen, R. L., Clark, C. F., and Moore, M. A., "Synthetic Petroleum for Department of Defense Use," AFAPL-TR-74-115, November 1974.
- 20.71 Shaw, H., Kalfadelis, C. D., and Jahnig, C. E., "Evaluation of Methods to Produce Aviation Turbine Fuels from Synthetic Crude Oils. Phase I..." AFAPL-TR-75-10, March 1975.
- 20.72 Bartick, H., Kunchal, K., Switzer, D., Bowen, R., and Edwards, R., "The Production and Refining of Crude Shale Oil into Military Fuels," Final Report for Contract N00014-75-C-0055, Office of Naval Research, Arlington VA, August 1975.
- 20.73 Pinkel, I. I., "Future Fuels for Aviation," AGARD Advisory Report No. 23, January 1976.
- 20.74 McClelland, C. C., "Effects of Jet Fuel Constituents on Combustor Durability," Naval Air Propulsion Test Center Report NAEP-AEL-1736, May 1963.
- 20.75 Butze, H. F., and Ehlers, R. C., "Effect of Fuel Properties on Performance of A Single Aircraft Turbojet Combustor," NASA-TM-X-71789, October 1975.
- 20.76 Macaulay, R. W., and Shaysen, M. W., "Effects of Fuel Properties on Liner Temperatures and Carbon Deposition in the CJ805 Combustor for Long Life Applications," ASME Paper 61-WA-304, October 1961.
- 20.77 Schirmer, R. M., McReynolds, L. A., and Daley, J. A., "Radiation from Flames in Gas Turbine Combustors," SAE Transactions, Vol 68, pp 554-561, 1960.
- 20.78 Gleason, C. C., and Bahr, D. W., "Experimental Clean Combustor Program Alternate Fuels Addendum Phase II Final Report," NASA-CR-134972, January 1976.
- 20.79 Adkins, R. C., "A Short Diffuser with Low Pressure Loss," ASME/CSME Fluids Engineering Conference, Montreal, Canada, 13-15 May 1974.
- 20.80 Cerkanowicz, A. E., Levy, M. E., and McAlevy, R. F., "The Photochemical Ignition Mechanism of Unsensitized Fuel-Air Mixtures," AIAA Paper No. 70-149, January 1970.
- 20.81 Cerkanowicz, A. E., "Photochemical Enhancement of Combustion and Mixing in Supersonic Flows," AFOSR-TR-74-0153, November 1973.
- 20.82 Weinberg, F. J., "The First Half Million Years of Combustion Research and Today's Burning Problems," 15th International Symposium on Combustion, the Combustion Institute, Pittsburgh PA, 1975.