

AD-A043 350

IIT RESEARCH INST CHICAGO ILL  
DETERMINATION OF THE PRINCIPAL MECHANICAL PROPERTIES OF REINFOR--ETC(U)  
APR 77 K E HOFER

F/G 11/9  
DAAA21-74-C-0114  
NL

UNCLASSIFIED

1 OF 1  
AD  
A043 350

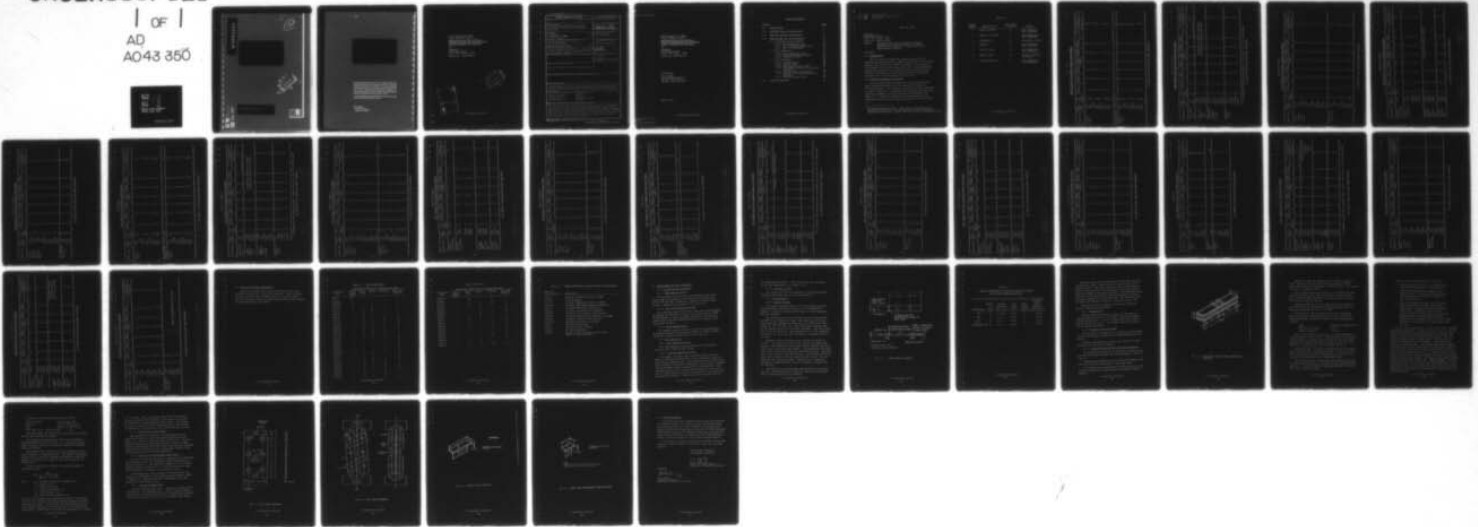

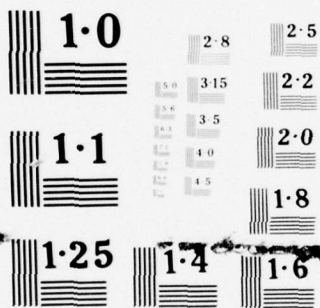

NATIONAL BUREAU OF STANDARDS  
MICROCOPY RESOLUTION TEST CHART

AD No. \_\_\_\_\_  
DDC FILE COPY

AD A 043350

Approved for public release;  
distribution unlimited.

**iITRI**

DDC  
AUG 23 1977  
REGISTERED  
C

12  
B.S.

Advanced concepts are being used by IIT Research Institute to solve research, development, and design problems for industry and government through contract research. Our services encompass virtually all of the physical and biological sciences. Principal areas are: chemistry, computer sciences, electronics, engineering mechanics, life sciences, mechanics of materials, medical engineering, metals, and management and social science research.

The interdisciplinary approach at IITRI brings the latest technology to bear upon the problem-solving process.

*Principal office:*  
10 West 35th Street  
Chicago, Illinois 60616

IITRI Project No. D6092  
Final Technical Report

DETERMINATION OF THE PRINCIPAL  
MECHANICAL PROPERTIES OF REINFORCED  
PLASTIC LAMINATES FOR AIRCRAFT

for

Commander  
Picatinny Arsenal  
Dover, New Jersey 07801  
Attention: SARPA-FR-M-D

ACCESSION FOR	
AFIS	W.I. Section <input checked="" type="checkbox"/>
AND	B.II Section <input type="checkbox"/>
UNANNOUNCED	
SPECIALTY	
BY DISTRIBUTION/AVAILABILITY CODES	
DI	OF CIAL
A	

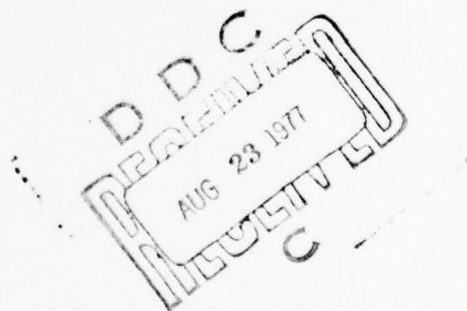

REPORT DOCUMENTATION PAGE		READ INSTRUCTIONS BEFORE COMPLETING FORM
1. REPORT NUMBER	2. GOVT ACCESSION NO.	3. RECIPIENT'S CATALOG NUMBER
4. TITLE (and Subtitle) DETERMINATION OF THE PRINCIPAL MECHANICAL PROPERTIES OF REINFORCED PLASTIC LAMINATES FOR AIRCRAFT		5. TYPE OF REPORT & PERIOD COVERED Final Technical Report October 1973-April 1977
7. AUTHOR(s) K. E. Hofer IIT Research Institute Chicago, Illinois		6. PERFORMING ORG. REPORT NUMBER
9. PERFORMING ORGANIZATION NAME AND ADDRESS IIT Research Institute 10 West 35th Street Chicago, Illinois 60616		8. CONTRACT OR GRANT NUMBER(s) DAAA21-74-C-0114
11. CONTROLLING OFFICE NAME AND ADDRESS Plastics Technical Evaluation Center (DRDAR-LCA-OR) US Army Armament Research & Development Command Dover, New Jersey 07801		10. PROGRAM ELEMENT, PROJECT, TASK AREA & WORK UNIT NUMBERS IITRI Project No. D6092
14. MONITORING AGENCY NAME & ADDRESS (if different from Controlling Office)		12. REPORT DATE April 1977
		13. NUMBER OF PAGES 44
		15. SECURITY CLASS. (of this report) Unclassified
		15a. DECLASSIFICATION/DOWNGRADING SCHEDULE
15. DISTRIBUTION STATEMENT (of this Report)  Approved for public release; distribution unlimited.		
17. DISTRIBUTION STATEMENT (of the abstract entered in Block 20, if different from Report)		
18. SUPPLEMENTARY NOTES The citation in this report of the names of commercial firms or commercially available products or services does not constitute official endorsement or approval of such commercial firms, products, or services by the United States government.		
19. KEY WORDS (Continue on reverse side if necessary and identify by block number) Mechanical properties                      Laminates Physical properties                         Materials Determination                                Composite materials Reinforced plastics                         Aircraft		
20. ABSTRACT (Continue on reverse side if necessary and identify by block number) The purpose of the test program described in this report was to develop engineering data on the mechanical and physical properties of reinforced plastic laminates for aircraft. Following are the systems tested: Modmor I Graphite/Narmco 5208; AS Graphite/Hercules 3501-5; T300 Graphite/Narmco 5208; RAC-7350/1014S-24; Kevlar 49 (PRD III)/Hexcel F161. The laminates were subjected to the following tests: tension, fatigue, compression, in-plane shear, flexural and interlaminar shear, and bearing stress.		

IITRI Project No. D6092  
Final Technical Report

DETERMINATION OF THE PRINCIPAL  
MECHANICAL PROPERTIES OF REINFORCED  
PLASTIC LAMINATES FOR AIRCRAFT

for

Commander  
Picatinny Arsenal  
Dover, New Jersey 07801  
Attention: SARPA-FR-M-D

Prepared by:

K. E. Hofer  
IIT Research Institute  
10 West 35th Street  
Chicago, Illinois 60616

April, 1977

IIT RESEARCH INSTITUTE

## TABLE OF CONTENTS

<u>Section</u>	<u>Page</u>
1.0 INTRODUCTION	1
2.0 MATERIALS RECEIVED AND ON HAND	1
3.0 DATA AND SPECIMEN TRANSMITTALS	23
4.0 CONDITIONING AND TEST PROCEDURES	27
4.1 Preconditioning Procedures	27
4.1.1 Room Temperature Dry	27
4.1.2 Dry II Preconditioning State	27
4.1.3 Wet Preconditioning	27
4.2 Test Conditions	27
4.2.1 Room Temperature Tests	27
4.2.2 Elevated Temperature Tests	27
4.2.3 Testing at -67°F	28
4.3 Test Procedures	28
4.3.1 Tension Testing	28
4.3.2 Fatigue Tests	31
4.3.3 Compression Testing (90°)	31
4.3.4 Compression Testing (0° and quasi-isotropic)	31
4.3.5 In-Plane Shear (Rail Shear)	36
4.3.6 Flexural and Interlaminar Shear Specimens	36
4.3.7 Bearing Strength Tests	36
5.0 CLOSING STATEMENT	41



IIT Research Institute  
10 West 35 Street, Chicago, Illinois 60616  
312/567-4000

April 28, 1977

Commander  
Picatinny Arsenal  
Dover, New Jersey 07801

Attention: SARPA-FR-M-D

Subject: "Determination of the Principal Mechanical  
Properties of Reinforced Plastic Laminates  
for Aircraft," Contract No. DAAA21-74-C-0114,  
Final Technical Report

Gentlemen:

#### 1.0 INTRODUCTION

This is the Final Technical progress report for IIT Research Institute Program No. D6092 conducted for the Picatinny Arsenal under Contract No. DAAA21-74-C-0114. The purpose of this program was to develop engineering data on the mechanical and physical properties of reinforced plastic laminates for aircraft. This report covers the work completed during the period October 25, 1973 through April 30, 1977.

#### 2.0 MATERIALS RECEIVED AND ON HAND

At the present time all materials to be evaluated have been evaluated and broken or scrap specimens returned to Picatinny Arsenal. The summary of the status of these materials is shown in Table 2-1. The Kevlar reinforced material was evaluated in accordance with the procedures recommended by Mil Hndbk 17\*. A detailed summary of the work performed on the remaining four materials is shown in Tables 2-2, 2-3, 2-4, and 2-5.

---

\* See Grumman Aerospace Corp., Final Report "Determination of Principal Properties of "E" Fiberglass High Temperature Epoxy Laminates for Aircraft," August 1969 under Contract DAAA21-68-C-0404.

Table 2-1

System Number	Identification	Total Panels Received	Status
1	Kevlar III/F161	4	Work Complete/ Data Submitted
2	Modmor I Gr./5208	13	Work Completed/ Data Submitted
3	E759/101S-24	18	Returned to Plastic
4	AS/3501	17	Work Completed/ Data Submitted
5	T300 Gr./5208	22	Work Completed/ Data Submitted
6	HMS Gr./3501	17	Material Returned to Plastic
7	RAC-7350/1014S-24	17	Work Completed/ Data Submitted

TEST PROGRAM FOR MODIOR I/NARMCO 5208 PANELS

Type Test	Test Condition	No. of Spec. Req'd	Panel Received	Sub. Panels	Spec. Blanks	Spec. Final Mach.	Conditioned	Spec. Tested	Data Procedure and	
									Submitted	Submitted
Tension 6(0)	- 67D	10	X	X	X	X	X	X		10
	75D	10*	X	X	X	X	X	X		10
	75DII	5	X	X	X	X	X	X		8
	75W	5	X	X	X	X	X	X		5
	180D	10*	X	X	X	X	X	X		10
	180DII	5	X	X	X	X	X	X		5
	180W	5	X	X	X	X	X	X		5
	260D	10*	X	X	X	X	X	X		10
	350D	10*	X	X	X	X	X	X		10

3

Type Test	Test Condition	No. of Spec. Req'd	Panel Received	Sub. Panels	Spec. Blanks	Spec. Final Mach.	Conditioned	Spec. Tested	Data Procedure and	
									Submitted	Submitted
Fatigue/6(0) Tension 6(90)	75°D	25**	X	X	X	X	X	X		34
	- 67D	10	X	X	X	X	X	X		10
	75D	10	X	X	X	X	X	X		10
	75DII	5	X	X	X	X	X	X		10
	75W	5	X	X	X	X	X	X		14
	180D	10	X	X	X	X	X	X		10
	180DII	5	X	X	X	X	X	X		15
	180W	5	X	X	X	X	X	X		4
	260D	10	X	X	X	X	X	X		8
	350D	10	X	X	X	X	X	X		10

ALL TESTS ON THIS PAGE HAVE BEEN COMPLETED

TABLE 2-4 (cont.)

TEST PROGRAM FOR MODMOR I/NARMCO 5208 PANELS

Type Test	Test Condition	No. of Spec. Reg'd	Panel Received	Sub. Panels	Spec. Blanks	Spec. Final Mach.	Conditioned	Spec. Tested	Data Procedure and Submitted	
									Submitted	Submitted
Rail Shear 6(0)	75D	10	X	X	X	X	X	X		14*
	180D	10	X	X	X	X	X			
Compression 6(0)	75DII	5	X	X	X	X	X	X		3
	180DII	5	X	X	X		insufficient material available			
	260DII	5	X	X	X		insufficient material available			
	350DII	5	X	X	X	X	X	X		3
ASTM D695 Compression 24(90)	75DII	5	X	X	X	X	X	X		5
	75W	5	X	X	X	X	X	X		5
	180DII	5	X	X	X	X	X	X		5
	180W	5	X	X	X	X	X	X		5
	260DII	5	X	X	X	X	X	X		5
Flexure 24(0)	350DII	5	X	X	X	X	X	X		5
	-67D	5	X	X	X	X	X	X		5
	75DII	5	X	X	X	X	X	X		5
	180DII	5	X	X	X	X	X	X		5
	260DII	5	X	X	X	X	X	X		5
	350DII	5	X	X	X	X	X	X		5

\* 10 specimens with detrusion gage; 4 with elec. res. foil strain gages

ALL TESTS ON THIS PAGE HAVE BEEN COMPLETED.

TABLE 2-2 (cont.)

TEST PROGRAM FOR MODMOR I/NARMCO 5208 PANELS

Type Test	Test Condition	No. of Spec. Req'd	Panel Received	Sub. Panels	Spec. Blanks	Spec. Final Mach.	Conditioned	Spec. Tested	Data Procedure and	
									Submitted	Submitted
Inter-	- 67D	5	x	x	x	x	x	x		5
Laminar	- 67W	5	x	x	x	x	x	x		5
Shear	67DII	5	x	x	x	x	x	x		5
	75DII	5	x	x	x	x	x	x		5
24(0)	75W	5	x	x	x	x	x	x		5
	180W	5	x	x	x	x	x	x		5
180DII	180DII	5	x	x	x	x	x	x		4
	260D	5	x	x	x	x	x	x		5
260DII	260DII	5	x	x	x	x	x	x		5
	260W	5	x	x	x	x	x	x		5
350DII	350DII	5	x	x	x	x	x	x		5
	350W	5	x	x	x	x	x	x		4
Tension	- 67D	10	x	x	x	x	x	x		5
	(0, ±45, 90) <sub>s</sub>	10	x	x	x	x	x	x		10
75DII	75DII	5	x	x	x	x	x	x		5
	75W	5	x	x	x	x	x	x		5
180D	180D	10	x	x	x	x	x	x		10
	180DII	5	x	x	x	x	x	x		5
180W	180W	5	x	x	x	x	x	x		5
	260D	10	x	x	x	x	x	x		10
350D	350D	10	x	x	x	x	x	x		10

ALL TESTS ON THIS PAGE HAVE BEEN COMPLETED

TABLE 2-2 (cont.)

TEST PROGRAM FOR MODMOR I/NARMCO 5208 PANELS

Type Test	Test Condition	No. of Spec. Req'd	Panel Received	Sub. Panels	Spec. Blanks	Spec. Final Mach.	Conditioned	Spec. Tested	Data Procedure and Submittal
Fatigue (0, ±45, 90) <sub>s</sub>	75D	25**	X	X	X	X	X	X	Submitted 25
Bearing (0, ±45, 90) <sub>s</sub>	- 67D	5	X	X	X	X	X	X	5
	75DII	5	X	X	X	X	X	X	5
	180DII	5	X	X	X	X	X	X	5
	260DII	5	X	X	X	X	X	X	5
	350DII	5	X	X	X	X	X	X	5
SW Beam	75DII	5	X	X		insufficient material available			
Compression	180DII	5	X	X		"			
	260DII	5	X	X		"			
	350DII	5	X	X		"			
Flexure	- 67D	5	X	X	X	X	X	X	5
	75DII	5	X	X	X	X	X	X	5
	350D	5	X	X	X	X	X	X	5

ALL TESTS ON THIS PAGE HAVE BEEN COMPLETED

TABLE 2-2 (cont.)  
TEST PROGRAM FOR MODMOR I/NARMCO 5208 PANELS

Type Test	Test Condition	No. of Spec. Req'd	Panel Received	Sub. Panels	Spec. Blanks	Spec. Final Mach.	Conditioned	Spec. Tested	Data Procedure and	
									Submitted	Submitted
Inter-	- 67D	5	X	X	X	X	X	X		5
Laminar	67DII	5	X	X	X	X	X	X		5
Shear	- 67W	5	X	X	X	X	X	X		5
3(0,±45, 90) <sup>s</sup>	75DII	5	X	X	X	X	X	X		5
	75W	5	X	X	X	X	X	X		5
	180DII	5	X	X	X	X	X	X		5
	180W	5	X	X	X	X	X	X		5
	260W	5	X	X	X	X	X	X		5
	350D	5	X	X	X	X	X	X		5
	350DII	5	X	X	X	X	X	X		5
	350W	5	X	X	X	X	X	X		5
45° Tension	75D	10	X	X	X	X	X	X		10
2(0,90) <sup>s</sup>	180D	10	X	X	X	X	X	X		10
	260D	10	X	X	X	X	X	X		10
	350D	10	X	X	X	X	X	X		10

ALL TESTS ON THIS PAGE HAVE BEEN COMPLETED

TABLE 2-3

TEST PROGRAM FOR AS GRAPHITE/3501 PANELS

Type Test	Test Condition	No. of Spec. Req'd	Panel Received	Sub. Panels	Spec. Blanks	Spec. Final Mach.	Conditioned	Spec. Tested	Data Procedure and Submittal
Tension 6(0)	- 67D	10	X	X	X	X	X	X	9
	75D	10*	X	X	X	X	X	X	11
	75DII	5	X	X	X	X	X	X	5
	75W	5	X	X	X	X	X	X	5
	180D	10*	X	X	X	X	X	X	10
	180DII	5	X	X	X	X	X	X	5
	180W	5	X	X	X	X	X	X	5
	260D	10*	X	X	X	X	X	X	10
	350D	10*	X	X	X	X	X	X	10
	∞								
<hr/>									
Fatigue/6(0)		75°D	25**	X	X	X	X	X	26
Tension 6(90)	- 67D	10	X	X	X	X	X	X	10
	75D	10	X	X	X	X	X	X	10
	75DII	5	X	X	X	X	X	X	5
	75W	5	X	X	X	X	X	X	5
	180D	10	X	X	X	X	X	X	10
	180DII	5	X	X	X	X	X	X	5
	180W	5	X	X	X	X	X	X	5
	260D	10	X	X	X	X	X	X	10
	350D	10	X	X	X	X	X	X	10

ALL TESTS ON THIS PAGE HAVE BEEN COMPLETED

TABLE 2-3 (cont.)

TEST PROGRAM FOR AS GRAPHITE/3501 PANELS

Type Test	Test Condition	No. of Spec. Req'd	Panel Received	Sub. Panels	Spec. Blanks	Spec. Final Mach.	Conditioned	Spec. Tested	Data Procedure and	
									Submitted	
Rail Shear	75D	10	X	X	X	X	X	X	14*	
6(0)	180D	10	X	X	X	X	X			
IITRI Compression	75DII	5	X	X	X	X	X	X	3	
	180DII	5	X	X	X		Insufficient material available			
	260DII	5	X	X	X		Insufficient material available			
	350DII	5	X	X	X	X	X	X	3	
IITRI Compression	75DII	5	X	X	X	X	X	X	5	
	75W	5	X	X	X	X	X	X	5	
	180DII	5	X	X	X	X	X	X	5	
	180W	5	X	X	X	X	X	X	5	
	260DII	5	X	X	X	X	X	X	5	
350DII	5	X	X	X	X	X	X	5		
Flexure	-67D	5	X	X	X	X	X	X	5	
	75DII	5	X	X	X	X	X	X	5	
	180DII	5	X	X	X	X	X	X	5	
	260DII	5	X	X	X	X	X	X	5	
	350DII	5	X	X	X	X	X	X	5	

\*10 specimens with detrusion gage; 4 specs. with elec. res. foil strain gages

ALL TESTS ON THIS PAGE HAVE BEEN COMPLETED

TABLE 2-3 (cont.)  
TEST PROGRAM FOR AS GRAPHITE/3501 PANELS

Type Test	Test Condition	No. of Spec. Req'd	Panel Received	Sub. Panels	Spec. Blanks	Spec. Final Mach.	Conditioned	Spec. Tested	Data Procedure and	
									Submitted	Submitted
Inter-	- 67D	5	x	x	x	x	x	x		5
Laminar	- 67W	5	x	x	x	x	x	x		5
Shear	- 67DII	5	x	x	x	x	x	x		5
24(0)	75W	5	x	x	x	x	x	x		5
	75DII	5	x	x	x	x	x	x		5
	180W	5	x	x	x	x	x	x		5
	180DII	5	x	x	x	x	x	x		5
	260D	5	x	x	x	x	x	x		5
	260W	5	x	x	x	x	x	x		5
	260DII	5	x	x	x	x	x	x		5
	350W	5	x	x	x	x	x	x		5
	350DII	5	x	x	x	x	x	x		5
Tension	- 67D	10	x	x	x	x	x	x		10
(0, ±45,	75D	10	x	x	x	x	x	x		10
90) s	75DII	5	x	x	x	x	x	x		5
	75W	5	x	x	x	x	x	x		5
	180D	10	x	x	x	x	x	x		10
	180DII	5	x	x	x	x	x	x		5
	180W	5	x	x	x	x	x	x		5
	260D	10	x	x	x	x	x	x		10
	350D	10	x	x	x	x	x	x		10
	420D	5	x	x	x	x	x	x		5

TABLE 2-3 (cont.)  
TEST PROGRAM FOR AS GRAPHITE/3501 PANELS

Type Test	Test Condition	No. of Spec. Req'd	Panel Received	Sub. panels	Spec. Blanks	Spec. Final Mach.	Conditioned	Spec. Tested	Data Procedure and Submitted
Fatigue (0, ±45, 90) <sub>s</sub>	75D	25**	X	X	X	X	X	X	25
Bearing (0, ±45, 90) <sub>s</sub>	- 67D	5	X	X	X	X	X	X	5
	75DII	5	X	X	X	X	X	X	5
	180DII	5	X	X	X	X	X	X	5
	260DII	5	X	X	X	X	X	X	5
	350DII	5	X	X	X	X	X	X	5
S Beam Compression 3(0, ±45, 90) <sub>s</sub>	75DII	5	X	X	X	X	X	X	5
	180DII	5	X	X	X	X	X	X	5
	260DII	5	X	X	X	X	X	X	5
	350DII	5	X	X	X	X	X	X	5
Flexure 3(0, ±45, 90) <sub>s</sub>	- 67D	5	X	X	X	X	X	X	5
	75DII	5	X	X	X	X	X	X	5
	350D	5	X	X	X	X	X	X	5

ALL TESTS ON THIS PAGE HAVE BEEN COMPLETED

TABLE 2-3 (cont.)

TEST PROGRAM FOR AS GRAPHITE/3501 PANELS

Type Test	Test Condition	No. of Spec. Req'd	Panel Received	Sub.- Panels	Spec. Blanks	Spec. Final Mach.	Condi- tioned	Spec. Tested	Data Procedure and	
									Submitted	Submitted
Inter-	- 67D	5	x	x	x	x	x	x		5
Laminar	- 67DII	5	x	x	x	x	x	x		5
Shear	- 65W	5	x	x	x	x	x	x		5
3(0, ±45, 90) <sub>s</sub>	75DII	5	x	x	x	x	x	x		5
	75W	5	x	x	x	x	x	x		5
	180DII	5	x	x	x	x	x	x		5
	180W	5	x	x	x	x	x	x		5
	260W	5	x	x	x	x	x	x		5
	350D	5	x	x	x	x	x	x		5
	350DII	5	x	x	x	x	x	x		5
	350W	5	x	x	x	x	x	x		5
45% Tension	-65D	10	x	x	x	x	x	x		10
2(0, 90) <sub>s</sub>	75D	10	x	x	x	x	x	x		10
	180D	10	x	x	x	x	x	x		10
	260D	10	x	x	x	x	x	x		10
	350D	10	x	x	x	x	x	x		9

ALL TESTS ON THIS PAGE HAVE BEEN COMPLETED

## TEST PROGRAM FOR T300 GRAPHITE/NARMCO 5208 PANELS

Type Test	Test Condition	No. of Spec. Req'd	Panel Received	Sub. Panels	Spec. Blanks	Spec. Final Mach.	Conditioned	Spec. Tested	Data Procedure and	
									Submitted	Submitted
Tension 6(0)	75DII	10	X	X	X	X	X	X		10
	75W	10	X	X	X	X	X	X		10
	180DII	10	X	X	X	X	X	X		10
	180W	10	X	X	X	X	X	X		10
	260DII	10	X	X	X	X	X	X		10
	350DII	10	X	X	X	X	X	X		10
Fatigue/6(0)		75DII	25	X	X	X	X	X		25
Tension 6(90)	75DII	5	X	X	X	X	X	X		5
	75W	5	X	X	X	X	X	X		5
	180DII	5	X	X	X	X	X	X		5
	180W	5	X	X	X	X	X	X		5
	260DII	5	X	X	X	X	X	X		5
	350DII	5	X	X	X	X	X	X		5

ALL TESTS ON THIS PAGE HAVE BEEN COMPLETED

TABLE 2-4 (cont.)

TEST PROGRAM FOR T300 GRAPHITE/NARMCO 5208 PANELS

Type Test	Test Condition	No. of Spec. Req'd	Panel Received	Sub. Panels	Spec. Blanks	Spec. Final Mach.	Conditioned	Spec. Tested	Data Procedure and Submittal	
									Submitted	
Rail Shear 6(0)	75DII	10	X	X	X	X	X	X		14*
	180DII	10	X	X	X	X	X			
IITRI Compression 6(0)	75DII	5	X	X	X				Insufficient material available	
	180DII	5	X	X	X		"	"		"
	260DII	5	X	X	X		"	"		"
	350DII	5	X	X	X		"	"		"
IITRI Compression 24(90)	75DII	5	X	X	X	X	X	X		5
	75W	5	X	X	X	X	X	X		5
	180DII	5	X	X	X	X	X	X		5
	180W	5	X	X	X	X	X	X		5
	260DII	5	X	X	X	X	X	X		5
Flexure 24(0)	350DII	5	X	X	X	X	X	X		5
	67DII	5	X	X	X	X	X	X		5
	75DII	5	X	X	X	X	X	X		5
	180DII	5	X	X	X	X	X	X		5
	350DII	5	X	X	X	X	X	X		5

\* 10 specimens with detrusion gage; 4 specimens with elec. res. foil strain gage

ALL TESTS ON THIS PAGE HAVE BEEN COMPLETED

TABLE 2-4 (cont.)

TEST PROGRAM FOR T300 GRAPHITE/NARMCO 5208 PANELS

Type Test	Test Condition	No. of Spec. Reg'd	Panel Received	Sub. Panels	Spec. Blanks	Spec. Final Mach.	Conditioned	Spec. Tested	Data Procedure and	
									Submitted	Submitted
Inter-	- 67DII	5	X	X	X	X	X	X		5
Laminar	- 67W	5	X	X	X	X	X	X		5
Shear	75DII	5	X	X	X	X	X	X		5
24(0)	75W	5	X	X	X	X	X	X		5
	180DII	5	X	X	X	X	X	X		5
	180W	5	X	X	X	X	X	X		5
	260DII	5	X	X	X	X	X	X		5
	260W	5	X	X	X	X	X	X		5
	350DII	5	X	X	X	X	X	X		5
	350W	5	X	X	X	X	X	X		4
Tension	75DII	10	X	X	X	X	X	X		10
(0, ±45, 90) <sub>s</sub>	75W	10	X	X	X	X	X	X		10
	180DII	10	X	X	X	X	X	X		10
	180W	10	X	X	X	X	X	X		10
	260DII	10	X	X	X	X	X	X		10
	350DII	10	X	X	X	X	X	X		10

ALL TESTS ON THIS PAGE HAVE BEEN COMPLETED

TEST PROGRAM FOR T300 GRAPHITE/NARMCO 5208 PANELS

Type Test	Test Condition	No. of Spec. Req'd	Panel Received	Sub. Panels	Spec. Blanks	Spec. Final Mach.	Conditioned	Spec. Tested	Data Procedure and Submittal	
									Submitted	Submitted
Fatigue (0, ±45, 90) <sub>s</sub>	75DII	25	x	x	x	x	x	x		25
Bearing (0, ±45, 90) <sub>s</sub>	75DII	5	x	x	x	x	x	x		5
	180DII	5	x	x	x	x	x	x		5
	260DII	5	x	x	x	x	x	x		5
	350DII	5	x	x	x	x	x	x		5
Sand. Beam Compression 3(0, ±45, 90) <sub>s</sub>	75DII	5	x	x	x	x	x	x		3
	180DII	5	x	x	x	x	x	x		3
	260DII	5	x	x	x	x	x	x		3
	350DII	5	x	x	x	x	x	x		3
Flexure 3(0, ±45, 90) <sub>s</sub>	67DII	5	x	x	x	x	x	x		5
	75DII	5	x	x	x	x	x	x		5
	180DII	5	x	x	x	x	x	x		5
	350DII	5	x	x	x	x	x	x		5

ALL TESTS ON THIS PAGE HAVE BEEN COMPLETED

TABLE 4-4 (cont.)

## TEST PROGRAM FOR T300 GRAPHITE/NARMCO 5208 PANELS

Type Test	Test Condition	No. of Spec. Req'd	Panel Received	Sub.- Panels	Spec. Blanks	Spec. Final Mach.	Conditioned	Spec. Tested	Data Procedure and	
									Submitted	Submitted
Inter-	- 67DII	5	x	x	x	x	x	x		5
Laminar	- 67W	5	x	x	x	x	x	x		5
Shear	75DII	5	x	x	x	x	x	x		5
3(0,±45, 90) <sub>s</sub>	75W	5	x	x	x	x	x	x		5
	180DII	5	x	x	x	x	x	x		5
	180W	5	x	x	x	x	x	x		5
	260DII	5	x	x	x	x	x	x		5
	260W	5	x	x	x	x	x	x		5
	350DII	5	x	x	x	x	x	x		5
	350W	5	x	x	x	x	x	x		5
45° Tension 2(0,90) <sub>s</sub>	75DII	5	x	x	x	x	x	x		5
	75W	5	x	x	x	x	x	x		5
	180DII	5	x	x	x	x	x	x		5
	180W	5	x	x	x	x	x	x		5
	260DII	5	x	x	x	x	x	x		5
	350DII	5	x	x	x	x	x	x		5

ALL TESTS ON THIS PAGE HAVE BEEN COMPLETED

TABLE 2-5

## TEST PROGRAM FOR RAC 7350/1014S-24 PANELS

Type Test	Test Condition	No. of Spec. Reg'd	Panel Received	Sub.- Panels	Spec. Blanks	Spec. Final Mach.	Conditioned	Spec. Tested	Data Procedure and	
									Submitted	Submitted
Tension 6(0)	75DII	10	X	X	X	X	X	X		10
	75W		X	X	X	X	X	X		10
	180DII	10	X	X	X	X	X	X		10
	180W	10	X	X	X	X	X	X		10
	260DII	10	X	X	X	X	X	X		10
	350DII	10	X	X	X	X	X	X		10
Fatigue/										
6(0)	75DII	25	X	X	X	X	X	X		25
Tension 6(90)	75DII	5	X	X	X	X	X	X		5
	75W	5	X	X	X	X	X	X		5
	180DII	5	X	X	X	X	X	X		5
	180W	5	X	X	X	X	X	X		5
	260DII	5	X	X	X	X	X	X		5
	350DII	5	X	X	X	X	X	X		5

ALL TESTS ON THIS PAGE HAVE BEEN COMPLETED

TEST PROGRAM FOR RAC 7350/1014S-24 PANELS

Type Test	Test Condition	No. of Spec. Req'd	Panel Received	Sub. Panels	Spec. Blanks	Spec. Final Mach.	Conditioned	Spec. Tested	Data Procedure and Submittal	
									Submitted	Submitted
Rail Shear 6(0)	75DII 180DII	10 10	X X	X X	X X	X X	X X	X		14*
IITRI Compression 6(0)	75DII 180DII 260DII 350DII	5 5 5 5	X X X X	X X X X	X X X X	X X X X	X X X X	X		Sand. beams buckled no further testing done
IITRI Compression 24(90)	75DII 75W 180DII 180W 260DII 350DII	5 5 5 5 5 5	X X X X X X	X X X X X X	X X X X X X	X X X X X X	X X X X X X	X X X X X X		5 5 5 5 5 5
Flexure 24(0)	- 67DII 75DII 180DII 350DII	5 5 5 5	X X X X	X X X X	X X X X	X X X X	X X X X	X X X X		5 5 5 5

\* 10 Specimens tested with detrusion gage; 4 specs. with elec. res. foil strain gages

ALL TESTS ON THIS PAGE HAVE BEEN COMPLETED

TEST PROGRAM FOR RAC 7350/1014S-24 PANELS

Type Test	Test Condition	No. of Spec. Reg'd	Panel Received	Sub. Panels	Spec. Blanks	Spec. Final Mach.	Conditioned	Spec. Tested	Data Procedure and	
									Submitted	Submitted
Inter-	- 67DII	5	X	X	X	X	X	X		5
Laminar	- 67W	5	X	X	X	X	X	X		5
Shear	75DII	5	X	X	X	X	X	X		5
24(0)	75W	5	X	X	X	X	X	X		5
	180DII	5	X	X	X	X	X	X		5
	180W	5	X	X	X	X	X	X		5
	260DII	5	X	X	X	X	X	X		5
	260W	5	X	X	X	X	X	X		5
	350DII	5	X	X	X	X	X	X		5
	350W	5	X	X	X	X	X	X		5
Tension	75DII	10	X	X	X	X	X	X		10
(0, ±45, 90) s	75W	10	X	X	X	X	X	X		10
	180DII	10	X	X	X	X	X	X		10
	180W	10	X	X	X	X	X	X		10
	260DII	10	X	X	X	X	X	X		10
	350DII	10	X	X	X	X	X	X		10

ALL TESTS ON THIS PAGE HAVE BEEN COMPLETED

TEST PROGRAM FOR RAC 7350/1014S-24 PANELS

Type Test	Test Condition	No. of Spec. Req'd	Panel Received	Sub. Panels	Spec. Blanks	Spec. Final Mach.	Conditioned	Spec. Tested	Data Procedure and Submittal	
									Submitted	Submitted
Fatigue	75DII	25	X	X	X	X	X	X		25
(0, ±45, 90) <sub>s</sub>										
Bearing	75DII	5	X	X	X	X	X	X		5
(0, ±45, 90) <sub>s</sub>	180DII	5	X	X	X	X	X	X		5
	260DII	5	X	X	X	X	X	X		5
	350DII	5	X	X	X	X	X	X		5
	75DII	5	X	X	X	X	X	X		Specimens buckled
Compression	180DII	5	X	X	X	X	X	-		no further testing
3(0, ±45, 90) <sub>s</sub>	260DII	5	X	X	X	X	X	-		could be performed
	350DII	5	X	X	X	X	X	-		
Flexure	- 67DII	5	X	X	X	X	X	X		5
3(0, ±45, 90) <sub>s</sub>	75DII	5	X	X	X	X	X	X		5
	180DII	5	X	X	X	X	X	X		5
	350DII	5	X	X	X	X	X	X		5

ALL TESTS ON THIS PAGE HAVE BEEN COMPLETED

TEST PROGRAM FOR RAC 7350/1014S-24 PANELS

Type Test	Test Condition	No. of Spec. Req'd	Panel Received	Sub. Panels	Spec. Blanks	Spec. Final Mach.	Conditioned	Spec. Tested	Data Procedure and	
									Submitted	Submitted
Inter-	- 67DII	5	X	X	X	X	X	X		5
Laminar	- 67W	5	X	X	X	X	X	X		5
Shear	75DII	5	X	X	X	X	X	X		5
3(0, ±45, 90) s	75W	5	X	X	X	X	X	X		5
	180DII	5	X	X	X	X	X	X		5
	180W	5	X	X	X	X	X	X		5
	260DII	5	X	X	X	X	X	X		5
	260W	5	X	X	X	X	X	X		5
	350DII	5	X	X	X	X	X	X		5
	350W	5	X	X	X	X	X	X		5
45° Tension	75DII	5	X	X	X	X	X	X		5
2(0, 90) s	75W	5	X	X	X	X	X	X		5
	180DII	5	X	X	X	X	X	X		5
	180W	5	X	X	X	X	X	X		5
	260DII	5	X	X	X	X	X	X		5
	350DII	5	X	X	X	X	X	X		5

Panel Unacceptable For Testing

ALL TESTS ON THIS PAGE HAVE BEEN COMPLETED

### 3.0 DATA AND SPECIMEN TRANSMITTALS

Data were transmitted to Picatinny Arsenal as the work on that particular test series was completed. Table 3-1 shows the dates on which data transmissions were made from IITRI. Table 3-2 shows the dates on which broken specimens were shipped to Picatinny Arsenal from IITRI.

Table 3-1. DATA TRANSMITTALS

Transmittal Date	Information Submitted on Following Systems				
	Kevlar Woven/ AF131	Mod I/ 5208	AS3501	T300/5208	RAC 7350/ 1014S-24
3/5/74	x	-	-	-	-
4/30/74	x	-	-	-	-
10/16/74	x	-	-	-	-
2/18/75	-	-	x	-	-
4/25/75	-	x	x	-	-
5/2/75	-	x	x	-	-
5/22/75	-	x	-	-	-
6/29/76	-	x	x	x	x
7/2/76	-	x	-	x	x
7/13/76	-	x	x	x	x
7/19/76	-	x	-	-	x
7/28/76	-	x	x	x	x
7/29/76	-	x	x	x	-
8/11/76	-	x	x	-	-
8/12/76	-	x	x	x	x
8/16/76	-	-	-	-	x
8/19/76	-	-	-	-	x
9/3/76	-	-	-	-	x
9/20/76	-	-	-	-	x
10/4/76	-	-	-	x	x
10/13/76	-	x	x	-	-
7/30/76	-	-	-	-	x
8/3/76	-	x	x	-	x
8/4/76	-	x	x	x	x
12/3/76	-	x	x	x	-
12/7/76	-	-	-	x	x
1/25/77	-	x	-	x	x
2/3/77	-	x	-	-	-
2/11/77	-	x	-	x	-
2/15/77	-	x	-	x	x

Table 3-1 (Cont.)

Transmittal Date	Information Submitted on Following Systems				
	Kevlar Woven/ AF131	Mod I/ 5208	AS5301	T300/5208	RAC 7350/ 1014S-24
2/16/77	-	x	-	x	-
2/18/77	-	x	-	x	-
2/21/77	-	x	x	x	-
2/22/77	-	-	x	-	x
2/23/77	-	-	-	-	x
2/24/77	-	-	x	x	x
2/28/77	-	-	x	-	-
3/5/77	-	x	x	x	x
3/7/77	-	x	-	-	x
3/9/77	-	x	-	x	x
3/11/77	-	-	-	x	-
3/21/77	-	x	-	x	x
3/22/77	-	-	-	-	x
3/24/77	-	-	-	x	-
3/25/77	-	-	-	x	x
3/26/77	-	-	x	-	-
3/28/77	-	-	x	x	-
4/26/77	-	x	x	x	x

Table 3-2. BROKEN SPECIMENS AND EXTRA MATERIAL TRANSMITTALS

Date of Transmittal	Description
3/4/74	60 creep specimen for test at AMMRC
3/22/74	1 PRD 49 panel
12/2/74	9 panels composite material to AMMRC
10/13/75	18 panels E759/1014S composite material
4/8/76	17 panels HM Graphite/3501 epoxy
4/12/76	25 pieces extra material T300/5208
4/12/76	24 pieces miscellaneous spare material
12/9/76	14 pieces miscellaneous composites to AMMRC
12/9/76	2 panels composite scrap material
12/17/76	42 bags tested Kevlar specimens
2/4/77	1403 tested specimens
2/22/77	222 bags tested specimens
3/7/77	67 tested specimens
4/28/77	30 bags tested specimens and 50 tested compr. S. beam specimens

#### 4.0 CONDITIONING AND TEST PROCEDURES

##### 4.1 Preconditioning Procedures

###### 4.1.1 Room Temperature Dry

All specimens tested in the room temperature dry state were placed in a temperature and humidity controlled room ( $75^{\circ}\text{F} \pm 2^{\circ}\text{F}$  and  $50\% \pm 2\%$  RH) for a period of 72 hours prior to test. Testing was performed in the same room.

###### 4.1.2 Dry II Preconditioning State

All specimens tested in the dry state were preconditioned by heating the specimens in an air circulating oven at  $350^{\circ}\text{F}$  for 30 minutes to constant weight followed by insertion into a dessicator with newly opened dessicant for a period of 48 hours prior to test.

###### 4.1.3 Wet Preconditioning

All samples tested in the wet state were preconditioned by insertion into an environmental chamber at  $125^{\circ}\text{F}$  and  $95\% \pm 5\%$  RH for a period of 1000 hours prior to testing.

##### 4.2 Test Conditions

###### 4.2.1 Room Temperature Tests

All tests designated room temperature were conducted in air at  $75^{\circ}\text{F} \pm 2^{\circ}\text{F}$  and  $50\% \pm 2\%$  RH.

###### 4.2.2 Elevated Temperature Tests

All tension, flexural and interlaminar shear tests at  $180^{\circ}\text{F}$  to  $420^{\circ}\text{F}$  were conducted in air in a Missimers oven that operated by circulating air. The compression coupon ( $90^{\circ}$ ) tests were performed in the IITRI compression fixture using a nichrome wire wound wafer furnace controlled by a potentiometer. The sandwich beam tests at elevated temperatures were conducted in air in a specially-constructed oven operated by circulating air and auxilliary heaters. This oven fitted around the arms of

the sandwich-beam fixture. Rail shear tests were conducted at elevated temperature in a smaller oven.

#### 4.2.3 Testing at -67°F

All testing at -67°F was conducted in the Missimers Oven using gas from liquid CO<sub>2</sub> as the coolant medium.

### 4.3 Test Procedures

#### 4.3.1 Tension Testing

The tension specimens were the IITRI straight-sided tab-ended specimens described in detail in the ASTM D3039-74. Figure 4.1 shows the specimens and Table 4-1 shows dimensions for each specimen.

The tab material for the specimens was 3M Scotchply 1002 or 1009E in an orthotropic layup. The prepreg material was fabricated into laminates by 3M Company for IITRI in an alternating 0°, 90°, 0°, 90°, etc. fiber orientation (degrees were to the length direction of the final specimen). The outer plies were in the 0° direction. The tab material was press-laminated at 100 psi for 30 min at 300°F followed by a postcure for 4 hr at 350°F.

Bonding of the tab blanks to the laminate proceeded as follows. The laminate was wiped with a gauze pad soaked with acetone. The bonded area was sanded with No. 240 grit and wiped with a gauze pad soaked with acetone. The bonded area was wiped again with a gauze pad soaked with methylethyl ketone. Distilled water rinse was applied to the laminate. The laminate was dried in an oven at 160 to 175°F for approximately 15 min. The tab blank was then cleaned as above. The area to be bonded was mechanically sanded with No. 50 grit followed by sanding with No. 240 grit.

All blanks were then measured and thicknesses recorded on the tab. Matched pairs were marked for future identification after surface preparation for bonding.

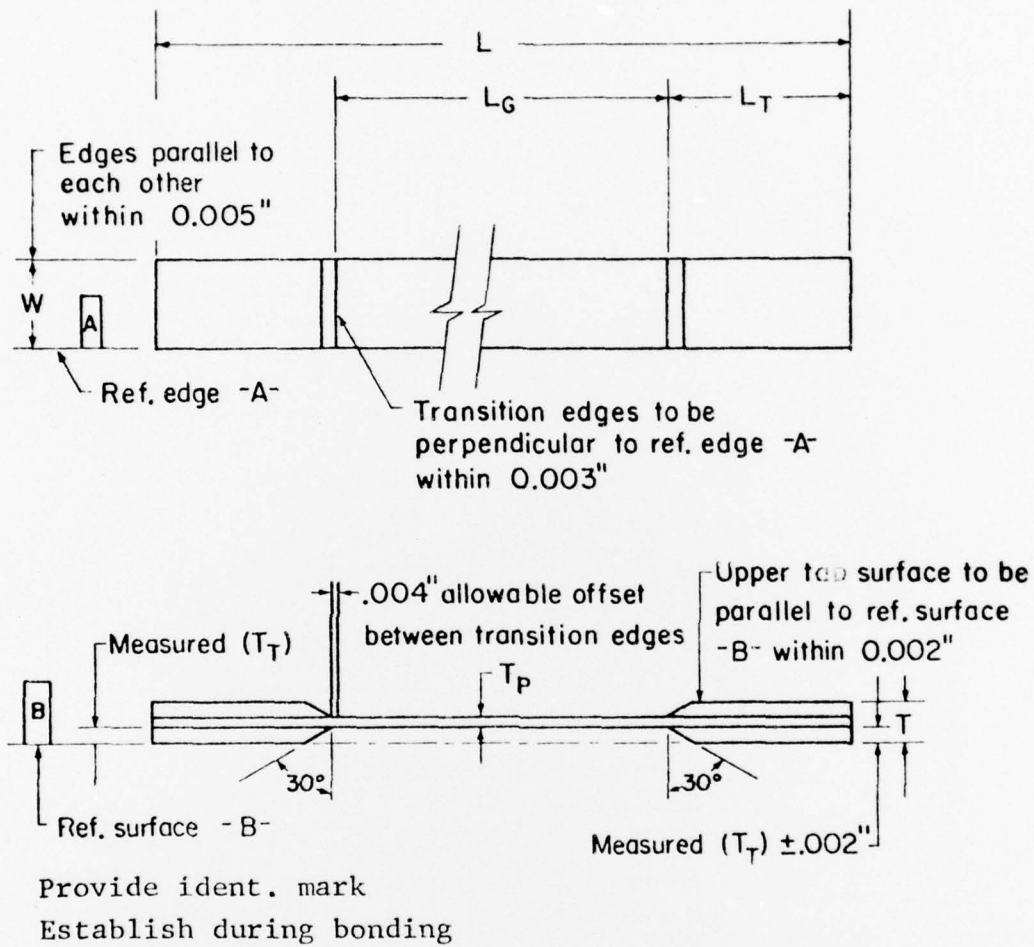

Fig. 4.1 IITRI TENSILE SPECIMEN

Table 4-1

NOMINAL DIMENSIONS OF TAB-ENDED TENSILE SPECIMENS  
FOR VARIOUS FIBER ORIENTATIONS

Orientation	Number of Plies	Overall Dimensions (in. x in.)	Tab Length (in.)	Stress Concen- tration	Tab Mat'l Room or Elevated Temp (R or E)
0°	6	9 x 1/2	1-1/2	1	R & E
90°	8	9 x 1	1-1/2	1	R & E
± 45°	8	9 x 1	1-1/2	1	R & E
(0°/90°/± 45°)	8	9 x 1	1-1/2	1	R & E

Specimen cutting was accomplished on a Rockwell saw with a diamond saw blade. Modifications of the saw were done to accomplish this. The upper arm of the saw was reinforced to prevent swaying of the motor assembly and a cutting support plate was mounted on the screw carriage. This permitted rigid retention of the specimen and uniform adjustment to insure cutting of specimens to the proper size. All specimens were cut within the allowed  $\pm 0.001$  in. tolerance on the width.

Tension tests were conducted in an Instron 10000 lb capacity tension testing machine.

#### 4.3.2 Fatigue Tests

Fatigue tests were conducted using the same type of specimens described in 4.3.1 on an SF 1-U Universal Fatigue Testing Machine at  $R = 0.1$  ( $R = \text{minimum stress per cycle} / \text{maximum stress per cycle}$ ). All fatigue testing was done in air at ambient conditions.

#### 4.3.3 Compression Testing ( $90^\circ$ )

The compressive specimen used in testing the five laminates was the Celanese specimen in the IITRI Compressive Test Fixture.

Specimen preparation procedures were similar to those described for the tensile coupons.

#### 4.3.4 Compression Testing ( $0^\circ$ and quasi-isotropic)

The compression testing of  $0^\circ$  and quasi-isotropic laminates was done using sandwich beam test specimens as shown in Fig. 4.2.

Sandwich beam specimens for the lamina and laminate compression tests were fabricated as described below.

The sandwich beam fabrication procedures are well established and follow the specifications originated by General Dynamics.

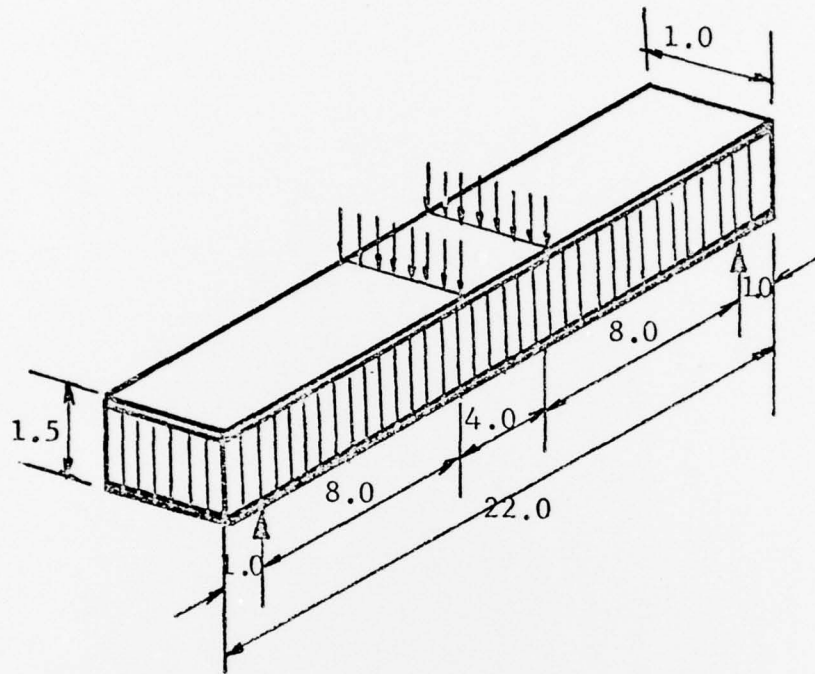

Fig. 4.2 FOUR-POINT SANDWICH BEAM COMPRESSION SPECIMEN

Composite skins were prepared by the methods described above; they were then wiped with methyl-ethylketone (MEK) using clean surgical cotton gauze and then dried in a circulating air oven for 30 min at 150°F.

Glass laminate skins were sanded on the bonding side with metalite 240 gril cloth, wiped first with acetone on clean gauze, then with MEK, rinsed with distilled water and finally oven dried at 150°F for 60 min.

Aluminum honeycomb core was positioned on the degreaser grill and washed by pouring fresh trichloroethylene over it, followed by exposure to 30 min. at 150°F.

Aluminum plate and skin details were first wiped with MEK on clean gauze, degreased 30 min. in vapors of boiling trichloroethylene and then dry cleaned in the following acid solution:

Water	30 parts by weight (p.b.w.)
Sulfuric Acid (66Be)	10 p.b.w.
Sodium-dichromate	1 p.b.w.

Parts were immersed 9 to 15 min. in an acid-dichromate solution heated at 120 to 155°F. Effectiveness of the cleaning was noted when a continuous film of water was obtained after rinsing in tap water followed by distilled water. Parts were dried in a circulating air oven for 30 min. at 150°F.

During cleaning, all parts were handled with clean rubber gloves and dried with clean cotton gloves. In oven and trays, and during specimen assembly, precautions were taken to maintain part cleanliness by use of clean Kraft paper.

Film adhesives were removed from cold storage and brought to room temperature prior to removal from their sealed plastic containers. Strips of adhesive approximately 1/8 in. oversize were cut to bond the facings.

Assembly of the sandwich beam was as follows:

1. A double ply of adhesive was attached to the prepared bonding surface of both adherends.
2. Pressure was applied to the adhesive with a rubber roller to assure complete adhesion to the facing while the exterior release film was still in place.
3. With the prepared honeycomb core positioned between wood blocks on clean Kraft paper, each facing in turn was aligned and attached to the core. Attachment was assisted by pressure applied to the outside of the facing. Completed green sandwich beams were then enclosed in one thickness wrap of five mil thick Capron film held closed with common paper masking tape.

To cure the sandwich beams, a 35 by 15 by 1/4 in. aluminum backplate equipped with a vacuum nozzle and a pair of 700 watt heaters were available on which the beams were mounted and bagged. Beams were alternated with wood blocks of the same size and grouped within a wooden frame. The beam near the center was instrumented at mid-length at the primary and secondary facing glue line. The bagging operation consisted of using gauze over the vacuum part in contact with a sheet of style 181 glass cloth bleeder laid over the beams and frame. The bag, an approximately 30 by 14 in. sheet of five mil thick Capron, was laid over the beam assembly and sealed to the backplate with vacuum bag sealant. The bag was placed under maximum vacuum pressure with a vacuum pump. During pumpdown, the film was smoothed flat over the beams and a leak check made. After sealing any leaks, the vacuum was held for up to 16 hours (overnight) before installation in the autoclave and application of heat and pressure.

The typical cure cycle achieved was as follows:

Vacuum pressure	27 to 29 in. gage
Heat up	77°F to 350°F 45 min.
Cure	350°F to $\pm 10^\circ\text{F}$ 60 min.
Cool down to R.T. under pressure	2.5 hr.

The cured beams were removed from the vacuum bag assembly and the film covering was removed.

The sandwich beam compressive tests were performed as shown schematically earlier in Fig. 4.2. For elevated temperature testing, an oven box specially prepared for sandwich beams was employed.

The sandwich beam stabilized the thin laminates by continuous bonding to a honeycomb core. The uniform and uniaxial stress state is assured by bending the assembly so that only membrane stresses occur in the top and bottom skins of the sandwich beam.

Ultimate compressive strength is calculated from the following equation:

$$\sigma_{cu} = \frac{MP}{\left[2t_1 + t_c + \frac{(t_1 + t_2)}{2}\right]}$$

where:  $\sigma_{cu}$  = ultimate compressive strength, psi  
M = moment arm, in.  
P = applied load, lbs.  
 $t_1$  = composite thickness, in.  
 $t_c$  = core thickness, in.  
 $t_2$  = opposite face thickness, in.

In testing of sandwich beam compression specimens and reducing the data, the following deviation from the generally accepted procedures was made: to accommodate the high deflection materials without slippage of the support pads, the distance from end support to load application point was shortened from 8 inches

to 7.0 inches. This was done for both the 0° and laminate material systems of the Boron/Avco 5505 composites and for the 0° Modmor II Graphite/Narmco 5206 systems. This change was noted on the data sheets submitted to Picatinny Arsenal and should be accounted for in the calculations for stresses.

#### 4.3.5 In-Plane-Shear (Rail Shear)

The specimen to be used for the determination of in-plane shear properties is the rail-shear specimen shown in Figure 4.3. The test setup is shown in Figure 4.4. Test procedures followed were those described by K. Boller in AFML-TR-69-311 dated March 1970 except that strain data was obtained using electrical resistance foil strain gages instead of the detrusion gage for all oriented composites.

#### 4.3.6 Flexural and Interlaminar Shear Specimens

Flexural tests were performed in accordance with ASTM-D790. The specimen used for all allowable flexural testing was as shown in Figure 4.5. Specimens were loaded in a 3 or 4-point bending fixture as shown in 4.5. Elevated temperature tests were conducted in a Missimer circulating air oven.

The interlaminar shear strength of oriented fiber composites was determined on short beam shear specimens as shown in Figure 4.6. Elevated and -65°F temperature tests were performed in the Missimer oven.

#### 4.3.7 Bearing Strength Tests

Bearing strength tests were conducted in accordance with ASTM D953-54. The specimens were 3/4 in. long by 0.938 in. wide by 1/8 in. thick with a 0.125 in. diameter hole centrally located approximately at 3/4 in. from the end of the sample.

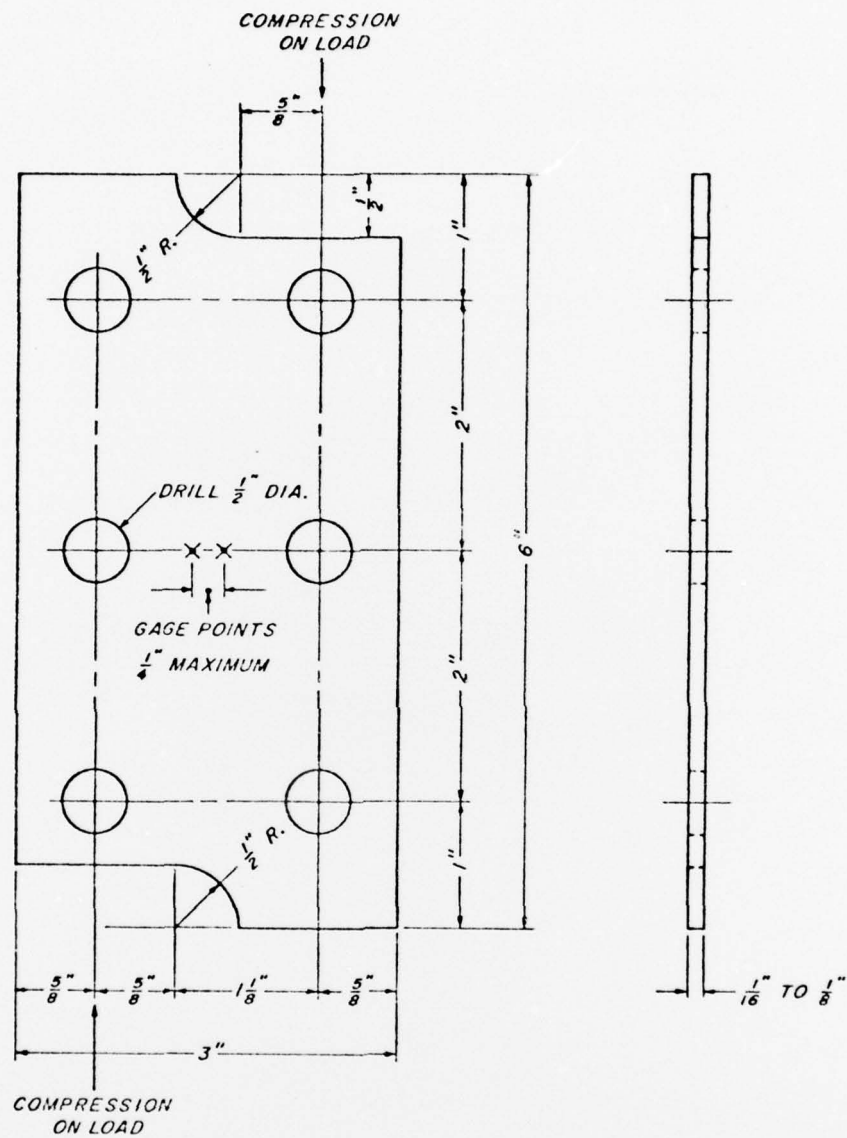

Fig. 4.3 RAIL SHEAR SPECIMEN

IIT RESEARCH INSTITUTE

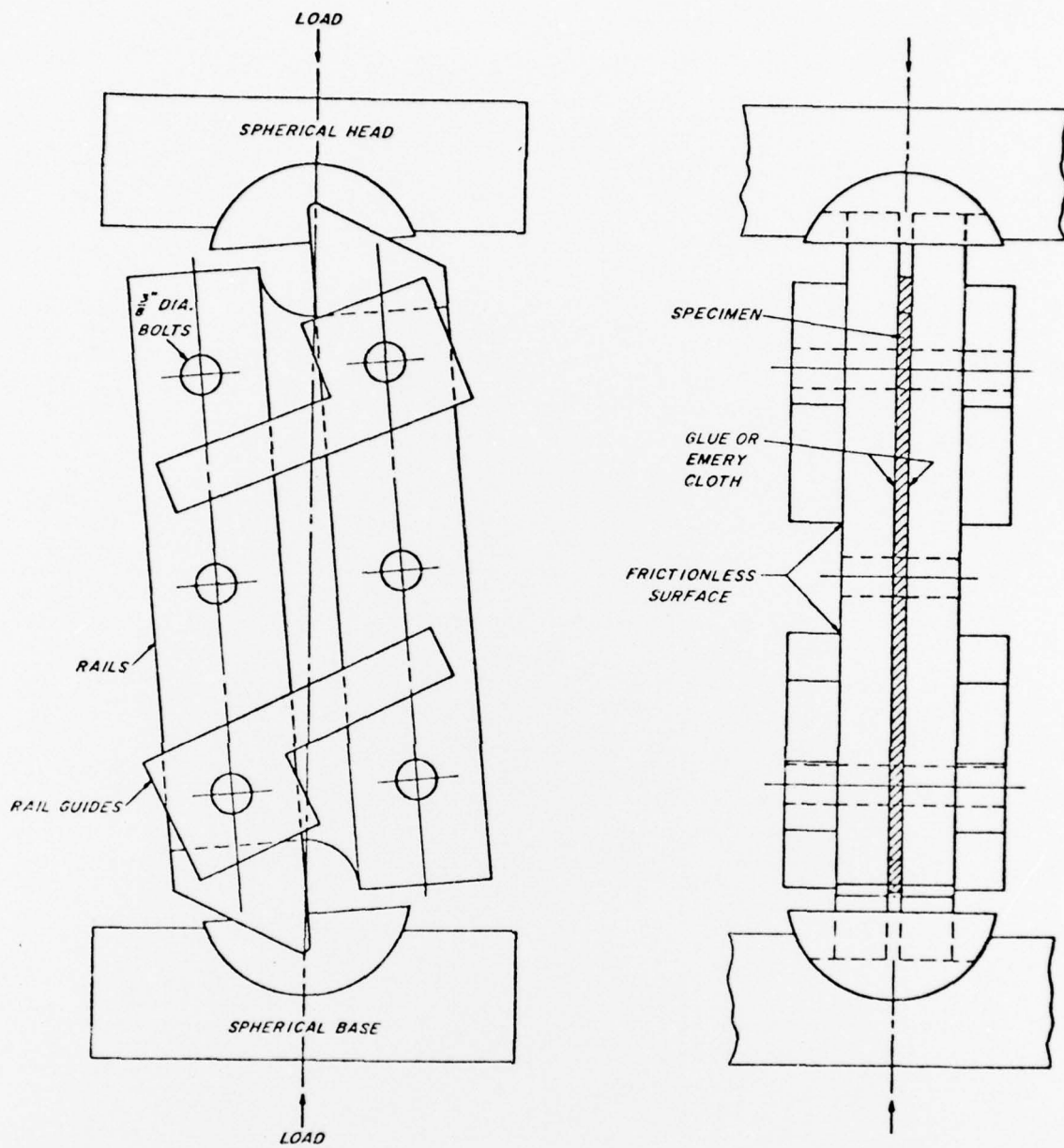
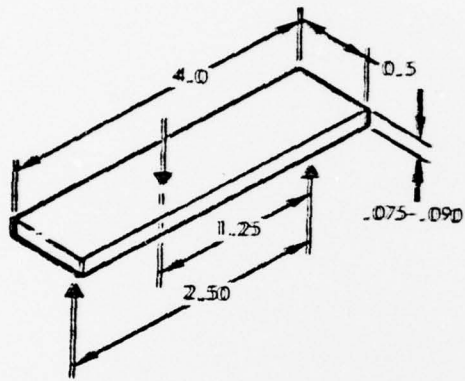

Fig. 4.4 RAIL SHEAR APPARATUS



(a) 0° Flexure

FILAMENTS SHALL BE PARALLEL TO LENGTH

Fig. 4.5 FLEXURAL TEST SPECIMEN

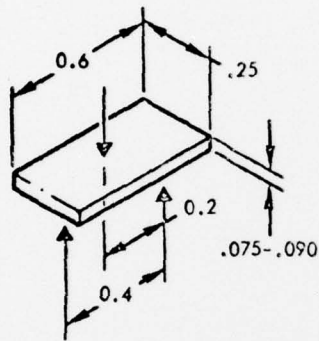

FILAMENTS SHALL BE PARALLEL  
TO LENGTH

NOTES:

- (1) Load and reaction supports shall be 1/8" radius steel rod
- (2) Load head travel rate shall be 0.05" per minute

Fig. 4.6 SHORT BEAM INTERLAMINAR SHEAR SPECIMEN

5.0 CLOSING STATEMENT

All testing has been completed and the raw data submitted to Picatinny Arsenal for further analysis and dissemination. All broken specimens have been returned to Picatinny under separate cover and all specimens fabricated by IITRI and panels fabricated by the material suppliers which were requested for other studies at Plastech or AMMRC have been transmitted per verbal or written request of the Picatinny program monitor.

It has been a pleasure working with Picatinny and we look forward to future programs of a similar nature for Picatinny Arsenal.

Respectfully submitted,  
IIT RESEARCH INSTITUTE

*K. E. Hofer, Jr.*

K. E. Hofer, Jr.  
Senior Research Engineer  
Mechanics of Materials Division

APPROVED:

*S. A. Bortz*

S. A. Bortz  
Assistant Director  
Mechanics of Materials Division