

AD-A043 716

ARMY MOBILITY EQUIPMENT RESEARCH AND DEVELOPMENT COMM--ETC F/G 13/2
PROCESS DESIGN FOR TREATING SHOWER WASTEWATER BY ULTRAFILTRATIO--ETC(U)
JUN 77 D S LENT

UNCLASSIFIED

MERADCOM-2212

NL

1 OF 2
AD
A043716

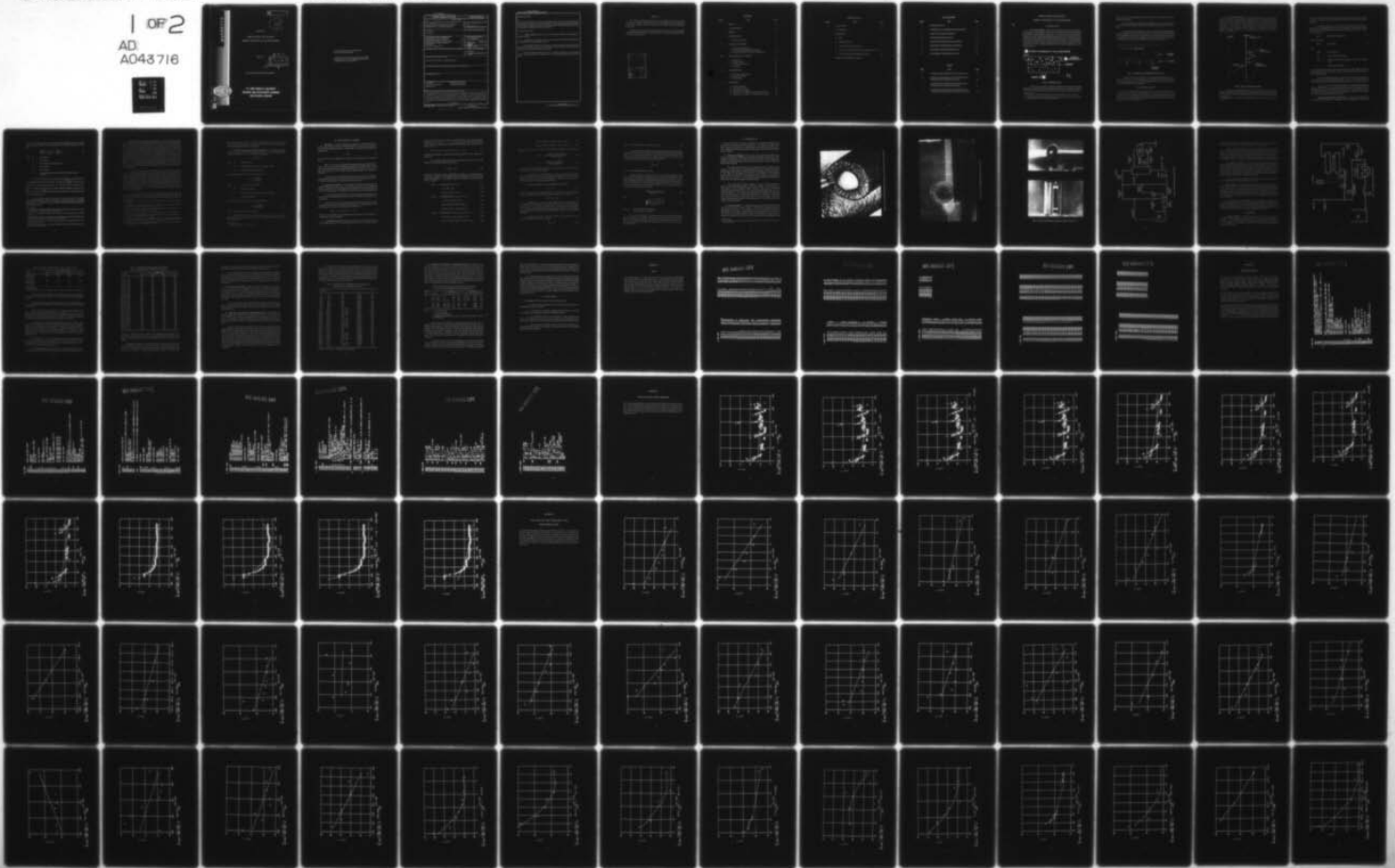

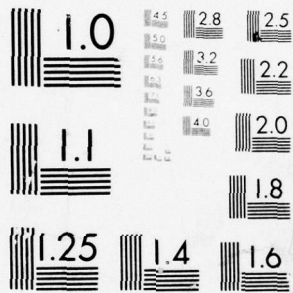

MICROCOPY RESOLUTION TEST CHART
NATIONAL BUREAU OF STANDARDS-1963-A

AD

12
NW

Report 2212

PROCESS DESIGN FOR TREATING
SHOWER WASTEWATER BY ULTRAFILTRATION

June 1977

DDC
RECEIVED
SEP 2 1977
B

Approved for public release; distribution unlimited.

U.S. ARMY MOBILITY EQUIPMENT
RESEARCH AND DEVELOPMENT COMMAND
FORT BELVOIR, VIRGINIA

ADA 043716

DDC FILE



Destroy this report when it is no longer needed.
Do not return it to the originator.

The citation in this report of trade names of commercially available products does not constitute official endorsement or approval of the use of such products.

UNCLASSIFIED

SECURITY CLASSIFICATION OF THIS PAGE (When Data Entered)

REPORT DOCUMENTATION PAGE		READ INSTRUCTIONS BEFORE COMPLETING FORM	
1. REPORT NUMBER 2212 ✓ (4) MERADCOM-2212	2. GOVT ACCESSION NO.	3. RECIPIENT'S CATALOG NUMBER	
4. TITLE (and Subtitle) 6 PROCESS DESIGN FOR TREATING SHOWER WASTEWATER BY ULTRAFILTRATION		5. TYPE OF REPORT & PERIOD COVERED 9 Final rept.	
7. AUTHOR(s) 10 Daniel S. Lent		6. PERFORMING ORG. REPORT NUMBER	
9. PERFORMING ORGANIZATION NAME AND ADDRESS Sanitary Sciences Division, DRDME-GS Energy & Water Resources Laboratory MERADCOM, Fort Belvoir, Virginia 22060		8. CONTRACT OR GRANT NUMBER(s)	
11. CONTROLLING OFFICE NAME AND ADDRESS MERADCOM Fort Belvoir, Virginia 22060		10. PROGRAM ELEMENT, PROJECT, TASK AREA & WORK UNIT NUMBERS 16 1L762720D048-07 1707	
14. MONITORING AGENCY NAME & ADDRESS (if different from Controlling Office)		12. REPORT DATE 11 June 1977	
		13. NUMBER OF PAGES 180 122 177p.	
		15. SECURITY CLASS. (of this report) Unclassified	
		15a. DECLASSIFICATION/DOWNGRADING SCHEDULE	
16. DISTRIBUTION STATEMENT (of this Report) Approved for public release; distribution unlimited.			
17. DISTRIBUTION STATEMENT (of the abstract entered in Block 20, if different from Report)			
18. SUPPLEMENTARY NOTES			
19. KEY WORDS (Continue on reverse side if necessary and identify by block number) Ultrafiltration Spiral-Wound Membranes Concentration Polarization Hollow-Fiber Membranes Boundary Layer			
20. ABSTRACT (Continue on reverse side if necessary and identify by block number) This report investigates curve fitting for the empirical explanation of shower wastewater treatment by ultrafiltration. A two-part model is proposed where, initially, the system is at unsteady state caused by the formation of the boundary layer. Later, the system comes to a steady state when the rates of boundary layer formation and decay reach constant values. The unsteady state portion is described by an exponential equation and the steady state portion is described by a linear equation. (continued)			

DD FORM 1 JAN 73 1473 EDITION OF 1 NOV 65 IS OBSOLETE

UNCLASSIFIED

SECURITY CLASSIFICATION OF THIS PAGE (When Data Entered)

403160 i

UNCLASSIFIED

SECURITY CLASSIFICATION OF THIS PAGE(When Data Entered)

Block 20 (continued):

The model was evaluated on two separate ultrafiltration systems with each system utilizing a different membrane configuration. These configurations were the spiral-wound configuration which fit the model as stated and the hollow-fiber configuration which fit only the unsteady state portion of the model due to daily removal of the boundary layer.

The study concludes that:

- a. A single, empirical equation cannot describe permeate production by ultrafiltration of shower wastewater.
- b. A model based on unsteady and steady state phenomena of concentration polarization can empirically describe the ultrafiltration process.
- c. The hollow-fiber system can be described by a single, empirical equation of exponential order because the system as studied was never allowed to reach steady state. Therefore, the unsteady state equation described the system's operation.
- d. The spiral-wound membrane system can be described empirically by an exponential equation during the boundary layer formation and by a linear equation during steady state operation.

UNCLASSIFIED

ii SECURITY CLASSIFICATION OF THIS PAGE(When Data Entered)

PREFACE

This report was submitted to the Faculty of the College of Arts and Sciences of the American University, Washington, D.C., in partial fulfillment of the requirements for the degree of Master of Science in Chemistry. The material has been copyrighted by the author.

Computer time for this work was partially funded by project no. 1L762720D048, "Environmental Quality Research and Development," 07, "Wastewater Pollution Control," under work unit W-11.

ACCESSION for	
NTIS	White Section <input checked="" type="checkbox"/>
DDC	Buff Section <input type="checkbox"/>
UNANNOUNCED	<input type="checkbox"/>
JUSTIFICATION	
BY	
DISTRIBUTION/AVAILABILITY CODES	
Dist.	and/or SPECIAL
A	

CONTENTS

Section	Title	Page
	PREFACE	iii
	ILLUSTRATIONS	vi
	TABLES	vi
I	INTRODUCTION	1
	1. Previous Investigation	1
II	LITERATURE REVIEW	2
	2. Concentration Polarization	2
	3. Theoretical Studies of Mass-Transfer Rate	4
	4. Practical Considerations of Permeate Production	7
III	DEVELOPMENT OF THEORY	8
	5. Background	8
	6. General Curve Fit	8
	7. Least-Squares Curve Fit	8
	8. Correlation	10
IV	EXPERIMENTAL	12
	9. Membrane Configuration	12
	10. System Description	12
	11. Data Analysis	17
V	DISCUSSION	17
	12. Analysis of Results	17
	13. Proposition of Theory	20
	14. Proposition of the Model	21
	15. Application of the Model to the Hollow-Fiber System	21
	16. Application of the Model to the Spiral-Wound System	23

CONTENTS (cont'd)

Section	Title	Page
VI	CONCLUSIONS	24
	17. Conclusions	24
	APPENDICES	
	A. Data	25
	B. Computer Program	31
	C. Curve Fits for System Operation	39
	D. Curve Fits for Daily Operation of the Hollow-Fiber System	52
	E. Curve Fits for Segmented, Spiral-Wound Data	157
	METRIC CONVERSION FACTORS	170

ILLUSTRATIONS

Figure	Title	Page
1	Ultrafiltration Process	1
2	Configuration of an Ultrafiltration Membrane System	2
3	Causes of Concentration Polarization	3
4	Photomicrograph of Hollow Fiber	13
5	Hollow-Fiber Ultrafiltration Membrane Module	14
6	Spiral-Wound Ultrafiltration Membrane Module	15
7	Flow Diagram of the Hollow-Fiber System	16
8	Flow Diagram of the Spiral-Wound System	18

TABLES

Table	Title	Page
1	Coefficients of Determination for Various Orders of Fit	19
2	Coefficients of Determination for Time Periods Between Backflushings for the Hollow-Fiber System	20
3	Exponential-Curve-Fit Coefficients and Coefficients of Determination for the Hollow-Fiber System	22
4	First-Order and Exponential-Curve-Fit Coefficients and Coefficients of Determination for the Hollow-Fiber System	23

PROCESS DESIGN FOR TREATING SHOWER WASTEWATER BY ULTRAFILTRATION

I. INTRODUCTION

1. **Previous Investigation.** Since the first description of the osmotic pressure phenomenon by Abbe Nollet in 1748, scientists and engineers have been intrigued by the properties of semipermeable membranes.¹ In the past few decades, membrane development has made membrane separation processes practical.² As might be expected, membrane processes, particularly the ultrafiltration process which is shown in Figure 1, are playing an increasing role in water and wastewater treatment. The ultrafiltration process depends upon a pressure driving force and a membrane permeable to a component (B) in a liquid solution and impermeable to the other component (A) in the solution (Figure 1).

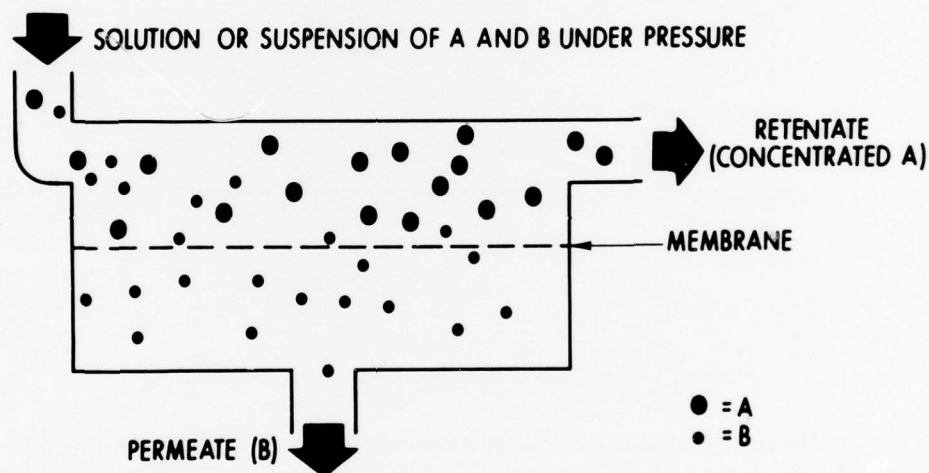

Figure 1. Ultrafiltration process.

When used for wastewater treatment, membranes are chosen that will retain impurities to be removed from the waste stream on one side of the membrane and collect water of desired quality from the other side. Therefore, the quality of effluent is

¹ F. Daniels and R. A. Alberty. *Physical Chemistry*, 3rd. Ed., John Wiley and Sons, Inc., New York, 1966.

² H. C. Gooding. "A Theoretical and Experimental Comparison of Unsteady and Steady State Ultrafiltration in Thin Horizontal Channels." M. S. Thesis, Clemson University, 1972.

fixed as a function of the membrane structure rather than as a function of the system operational parameters.

The most significant variable in the ultrafiltration process is water production expressed as flux with the units of flow (volume) per unit membrane area per unit time.

System optimization, therefore, is done by maximizing flux and minimizing the rate of decline of flux. This flux decline is due, in part, to a concentration buildup of the impermeable portion of the bulk solution at the membrane surface (concentration polarization). The system is configured as shown in Figure 2 with the bulk solution velocity parallel to the membrane surface, thus, reducing this buildup.

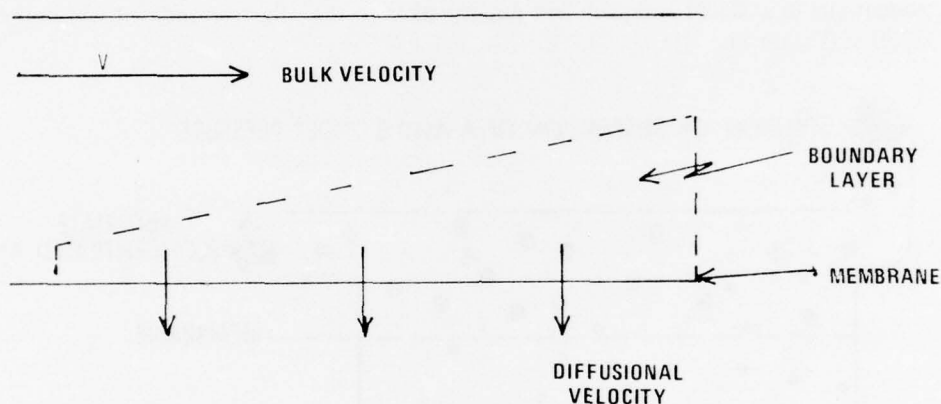

Figure 2. Configuration of an ultrafiltration membrane system.

The purpose of this investigation is to develop a mathematical model that describes the treatment of shower wastewater by ultrafiltration. The model is developed using transport principles for a general ultrafiltration system and is then used to evaluate actual ultrafiltration-system operation.

II. LITERATURE REVIEW

The two membrane-separation processes that use a pressure gradient across a membrane are reverse osmosis and ultrafiltration. They differ in that the solute and solvent molecular dimensions in reverse osmosis are generally of the same order of magnitude; whereas, in ultrafiltration the solute molecular diameters are at least ten times greater than the solvent molecular size.

2. **Concentration Polarization.** In a continuous operation of reverse osmosis or ultrafiltration systems, a phenomenon commonly referred to as concentration polarization often represents the rate major/rate controlling step.³ Concentration polarization is described as the accumulation of nontransferred solute in the boundary layer of the membrane as shown in Figure 3. This phenomenon is the result of the concentration of the solute at the membrane surface. As the solute concentrates, a concentration gradient is established resulting in a back diffusion of the solutes and reducing the transport of the solvent.

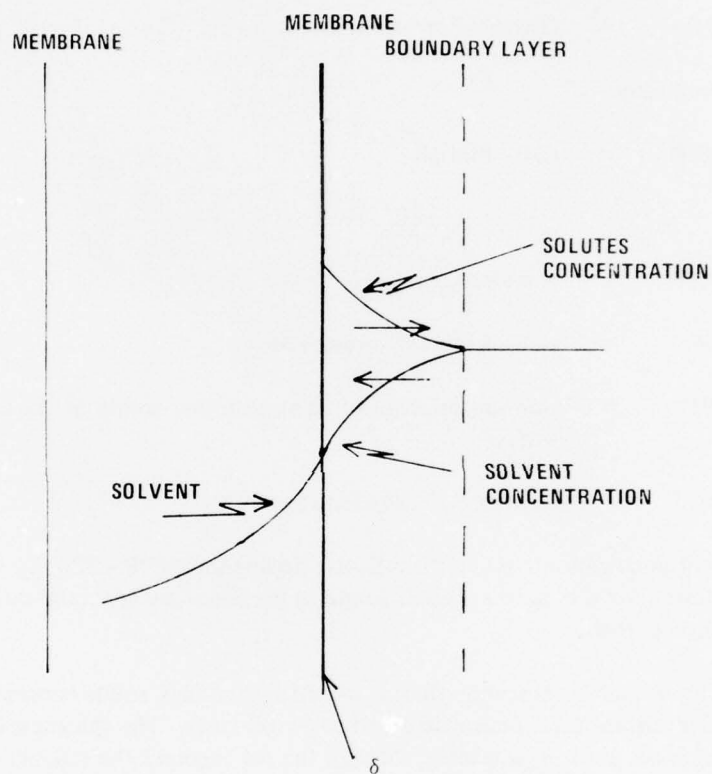

Figure 3. Causes of concentration polarization.

Solute may be transported away from the membrane surface by molecular diffusion perpendicular to the membrane (lateral direction) and by forced convection of the stream flow parallel to the membrane (axial direction). Eventually, steady state

³ N. Lakshiminarayanaiah. "Transport Phenomena in Artificial Membranes," *Chem. Reviews*, 65, No. 5, 491-565 (1965).

is achieved; and the rate of transport of solute to the membrane surface becomes equal to the rate of transport away from the surface if the process input variables remain unchanged.

Concentration polarization can have two detrimental effects on the mass-transfer rate in an ultrafiltration or a reverse osmosis system. The first detrimental effect is seen by considering the familiar equation relating mass-transfer rate, driving force, and resistance:

$$\text{Rate} = (\text{Driving Force})/(\text{Resistance}), \quad (1)$$

or, more specifically:

$$\text{MTR} = (\text{DP} - \text{PIM})/R \quad (2)$$

where:

MTR = mass-transfer rate

DP = transmembrane pressure drop

PIM = osmotic pressure of nontransferred solute at the membrane surface

R = resistance to mass transfer.

Concentration polarization reduces the effective driving force (DP - PIM) by increasing the concentration of the nontransferred solute in the boundary layer and thus increasing the osmotic pressure.

The second detrimental effect is caused by the high solute concentration at the membrane surface precipitating and forming a gel layer. The thickness of this gel layer will increase until mass transfer through the gel becomes the rate-limiting step.

In any event, once concentration polarization is controlling, increasing the pressure, or driving force, on the system will not increase the mass-transfer rate. The higher pressure causes a thicker layer of gel and, hence, a greater resistance to flow. The goal in process design is, therefore, to minimize the thickness of the boundary layer where concentration polarization takes place.

3. Theoretical Studies of Mass-Transfer Rate. In 1965, Brian developed a theoretical model for predicting the mass-transfer rate in a parallel-plate, reverse osmosis

system.⁴ His model involved a numerical solution of a simplified version of the steady state equation of continuity of the nontransferred solute. Brian's equation is as follows:

$$\frac{\partial(U \cdot C)}{\partial X} + \frac{\partial}{\partial Y} \left(VC - \frac{D\partial C}{\partial Y} \right) = 0 \quad (3)$$

where: U = axial velocity
X = axial distance
C = concentration in the liquid stream
Y = lateral distance
V = lateral velocity
D = effective diffusivity or reciprocal Peclet Number at initial conditions

The terms in Equation (3) are in direct correspondence with the theory of concentration polarization discussed earlier. The first term, $\frac{\partial(U \cdot C)}{\partial X}$, represents forced convection of solute axially through the cell. The first part of the second term, $\frac{\partial}{\partial Y} (V \cdot C)$, indicates bulk convection of solute toward the membrane; and the second part of the second term, $\frac{D\partial C}{\partial Y}$, represents molecular diffusion of rejected solute away from the membrane surface.

In related studies, Brian,⁵ Sherwood, *et al.*,⁶ and Gill, *et al.*^{7 8} developed slightly different models modifying the boundary conditions and solution techniques of Equation (3). Unfortunately, none of the studies included experimental verification of the predicted results.

⁴ P. L. T. Brian. "Concentration Polarization in a Reverse Osmosis Desalination with Variable Flux and Incomplete Salt Rejection," *Ind. Eng. Chem. Fund.*, 4, 439-45 (1965).

⁵ P. L. T. Brian. "Concentration Polarization in a Reverse Osmosis System," *Ind. Eng. Chem. Fund.*, 5, 148-149 (1965).

⁶ T. K. Sherwood, P. L. T. Brian, R. E. Fisher, and L. Dresler. "Salt Concentration of Phase Boundaries in Desalination by Reverse Osmosis," *Ind. Eng. Chem. Fund.*, 4, 113-18 (1965).

⁷ W. N. Gill, C. Tien, and D. W. Zeh. "Boundary Layer Effects in Reverse Osmosis Desalination," *Ind. Eng. Chem. Fund.*, 5, 367-70 (1966).

⁸ W. N. Gill, C. Tien, and D. W. Zeh. "Concentration Polarization Effects in a Reverse Osmosis System," *Ind. Eng. Chem. Fund.*, 4, 433-39 (1965).

With the increasing interest in the application of membrane-separation processes, several theoretical and experimental methods of reducing concentration polarization effects have been studied. Sherwood, *et al.*⁹ performed an experimental and theoretical investigation of a rotating, cylindrical, reverse osmosis apparatus for desalination and obtained partial confirmation of their previously developed theory.¹⁰ Rotation of the membrane resulted in total flux increases of approximately 10 percent. Zeh and Gill¹¹ published a theoretical model of a rotating-disk system, implying but not quantitatively reporting the beneficial effects of rotation on the mass-transfer rate. Increased velocities in laminar flow are also known to decrease concentration polarization by creating greater shear rates, and turbulent flow adds the mechanism of eddy mixing. With the highly permeable membranes available today, the fluid velocities required to significantly reduce concentration polarization become very large, and energy consumption and fluid recirculation rates required to achieve reasonable recovery become prohibitive.¹²

Tien and Gill¹³ theoretically investigated the use of impermeable "relaxation sections" to induce axial diffusion of the nontransferred solute, but their predictions indicated only a small increase in the steady state flux obtainable with an equivalent, entirely permeable area. Huffman¹⁴ studied the effect of natural convection on concentration polarization by using a horizontal, parallel-plate ultrafilter. He operated a single membrane, first in the lower position and then in the upper position, and obtained semitheoretical correlations for his forced-only and forced-plus-natural convection data. The study demonstrated that natural convection effects can increase the steady state, mass-transfer rate by as much as 200 percent over comparable conditions with forced convection only.

In 1972, Gooding¹⁵ experimentally validated his dynamic model of forced-convection ultrafiltration in thin, horizontal channels which requires a numerical solution of the unsteady state continuity equation for the nontransferred solute. He

⁹ T. K. Sherwood, P. L. T. Brian, and R. E. Fisher. "Desalination by Reverse Osmosis," *Ind. Eng. Chem. Fund.*, 6, 2-12 (1967).

¹⁰ T. K. Sherwood, P. L. T. Brian, R. E. Fisher, and L. Dresler. "Self Concentration of Phase Boundaries in Desalination by Reverse Osmosis," *Ind. Eng. Chem. Fund.*, 4, 113-18 (1965).

¹¹ D. W. Zeh and W. N. Gill. "Convective Diffusion in Rotating Disk Systems with an Imperfect Semi-permeable Interface," *Amer. Inst. Chem. Eng. Journal*, 14, 715-19 (1968).

¹² A. S. Michaels. "New Separation Technique for the CPI," *Chem. Eng. Prog.*, 64, No. 12, 31-43 (1968).

¹³ C. Tien and W. N. Gill. "The Relaxation of Concentration Polarization in a Reverse Osmosis Desalination System," *Amer. Inst. Chem. Eng. Journal*, 12, 722-27 (1966).

¹⁴ W. J. Huffman. "The Effect of Forced End Natural Convection During the Ultrafiltration of Protein-Saline Solutions in Thin, Horizontal Channels," *PhD Dissertation*. Clemson University Library, Clemson, S.C. (1970).

¹⁵ H. C. Gooding. "A Theoretical and Experimental Comparison of Unsteady and Steady State Ultrafiltration in Thin Horizontal Channels." *M.S. Thesis*, Clemson University (1972).

then used this model to study the possibility of improving mass transfer by using some form of unsteady state operation. Higher fluxes were predicted by the model but were not experimentally achieved in his investigation.

4. Practical Considerations of Permeate Production. The details of the derivation of the practical equation of concentration polarization control of ultrafiltrate flux have been worked out by others.¹⁶ Simply, the relationship is:

$$F = K \ln (C_g/C_b) \quad (4)$$

where: F = ultrafiltration flux

C_g = concentration of the gel at the membrane surface

C_b = concentration of the bulk stream

The mass-transfer coefficient is defined in laminar flow as:

$$K = \frac{V^{0.33} D^{0.67}}{h^{0.33} L^{0.33}} \quad (5)$$

where: V = velocity along the membrane

D = diffusivity of solvent

h = height of the channel in which the fluid is flowing

L = length of the channel.

In turbulent flow, the mass-transfer coefficient is defined as:

$$K = \frac{V^{0.75} D^{0.67}}{h^{0.25} \nu^{0.42}} \quad (6)$$

where ν = the kinematic viscosity of the fluid.

While these equations are useful in the predication of effects of channel height and length on flux, prediction of actual system operation for wastewater treatment is not possible.

¹⁶ S. Messinger, "Ultrafiltration - A New Process Tool."

III. DEVELOPMENT OF THEORY

5. **Background.** A mathematical function is defined as a relationship between a set of x values associated with the independent variable, x and a set of y values associated with the dependent variable, y . Symbolically, we described this mathematical relationship by:

$$y = f(x). \quad (7)$$

The function can also be displayed by a graph, or curve, depicting a set of data pairs (x, y) .

When we are given a mathematical equation describing a relationship between x and y , a curve corresponding to this relationship can be easily plotted. On the other hand, when dealing with experimental information, the opposite is true. From a given set of points (x, y) , we try to find a function which generates a curve fitting these data points.

For the purpose of this study, all functions are assumed to be continuous. This means that for every value of x in an interval (a, b) there is a unique value for $y = f(x)$ and that a small change in x produces only a small change in y .

6. **General Curve Fitting.** In technological applications, measurements are usually made of one quantity while a second quantity is varied with the results being plotted in graphical form. The problems lie in not being able to make measurements at every point of interest and the possibility of measurement error in the measurements.

To overcome these problems and to be able to represent the results in a compact manner, the experimenter often tries to fit the experimental measurements to a smooth curve.

The form of the curve selected will of course depend upon the type of measurements being made and the system under investigation. A standard function often used to represent a curve is a polynomial function of the form:

$$f(x) = a_0 + a_1 x + a_2 x^2 + \dots + a_u x^u. \quad (8)$$

The shape of the resulting curve depends both upon the value of the coefficients, a , and the degree of the polynomial, u .

7. **Least-Squares Curve Fit.** While trying to fit a curve to a set of data points, it is not possible to have the curve pass through each point. The most desirable condition

is the curve coming as close as possible to all the data points. If the set of data points is denoted as $(x_1, y_1), (x_2, y_2), \dots, (x_v, y_v)$, where x_i is the value of the independent variable when the measurement y_i was made, then the distance of the i data point from the curve $f(x)$ is:

$$d_i = y_i - f(x_i) = y_i - (a_0 + a_1 x_i + a_2 x_i^2 + \dots + a_u x_i^u). \quad (9)$$

This distance represents the "error" between the value given by the curve and the measured value.

The common formula that measures the difference between the curve and the data is the sum of the squared errors. That is:

$$C = \sum_{i=1}^n y_i - f(x_i)^2. \quad (10)$$

To minimize the total error, the coefficients of a through a_u are selected in such a manner as to minimize C . This function, having the smallest C value, is called a least-squares approximation. The conditions that must be satisfied are shown as follows for $u = 1, 2$, and 3 :

$$\text{Case 1: } u = 1 \text{ Linear fit, } f(x) = a_0 + a_1 x: \quad (11)$$

$$a_0 v + a_1 \sum x_i = \sum y_i \quad (12)$$

$$a_0 \sum x_i + a_1 \sum x_i^2 = \sum x_i y_i. \quad (13)$$

$$\text{Case 2: } u = 2 \text{ Quadratic fit, } f(x) = a_0 + a_1 x + a_2 x^2 \quad (14)$$

$$a_0 + a_1 \sum x_i + a_2 \sum x_i^2 = \sum y_i \quad (15)$$

$$a_0 \sum x_i + a_1 \sum x_i^2 + a_2 \sum x_i^3 = \sum x_i y_i \quad (16)$$

$$a_0 \sum x_i^2 + a_1 \sum x_i^3 + a_2 \sum x_i^4 = \sum x_i^2 y_i \quad (17)$$

$$\text{Case 3: } u = 3 \text{ Cubic fit, } f(x) = a_0 + a_1 x + a_2 x^2 + a_3 x^3 \quad (18)$$

$$a_0 + a_1 \sum x_i + a_2 \sum x_i^2 + a_3 \sum x_i^3 = \sum y_i \quad (19)$$

$$a_0 \sum x_i + a_1 \sum x_i^2 + a_2 \sum x_i^3 + a_3 \sum x_i^4 = \sum x_i y_i \quad (20)$$

$$a_0 \sum x_i^2 + a_1 \sum x_i^3 + a_2 \sum x_i^4 + a_3 \sum x_i^5 = \sum x_i^2 y_i \quad (21)$$

$$a_0 \sum x_i^3 + a_1 \sum x_i^4 + a_2 \sum x_i^5 + a_3 \sum x_i^6 = \sum x_i^3 y_i \quad (22)$$

These cases, in turn, can be solved for the different coefficients of a as shown in Case 1:

$$\text{Case 1: } a_0 = \frac{(\sum y_i)(\sum x_i^2) - (\sum x_i y_i)(\sum x_i)}{(\sum x_i^2) - (\sum x_i)^2} \quad (23)$$

$$\text{and } a_1 = \frac{v(\sum x_i y_i) - (\sum x_i)(\sum y_i)}{(\sum x_i^2)(\sum x_i^2)} \quad (24)$$

Or, more simply, the simultaneous equations can be solved directly by the method of elimination or by the use of determinants.

It can readily be seen that the higher the value of u the better the probable curve fit for nonlinear data. It can also be seen that the higher the value of u the more difficult it will be to solve for the coefficients of a . Therefore, other functions are tried and compared with results from polynomial fits.

One function considered is an exponential function as follows:

$$Y = ae^{bx} \quad (25)$$

At first, this appears to be a difficult function to work with; however, by taking the \log of both sides its form becomes a linear function similar to Case 1 as shown:

$$\log Y = \log a + b x \quad (26)$$

8. **Correlation.** Once a curve or a line is fitted to the data, the next problem is to determine how well the data is actually fitted by the curve. A fair idea is gained by inspection of the curve and the data points; however, usually a more objective evaluation is required. In studying the data, an assessment must be made of the probability of random variables rather than the independent variable contributing to the variability of the data.

Essentially, the problem is analysis of variance; and the quantity to be analyzed, the total sum of the squares, is given by:

$$\sum_{i=1}^n (y_i - \bar{y})^2 \quad (27)$$

where: \bar{y} = the mean of the y values given by $\bar{y} = \frac{\sum_{i=1}^n y_i}{n}$. (28)

If the independent variable were the only thing that affected the dependent variable, the data points would all fall on a straight line assuming a linear relationship. Since this is rarely true, other factors do tend to affect the dependent variable. The variation caused by these other factors is usually measured by the sum of the squares of the vertical deviations from the point to the line given by:

$$\sum_{i=1}^n (y_i - \hat{y})^2 \quad (29)$$

where \hat{y} = the individual, predicted y values.

This is identical to equation (10) or $f(x_i)$. The difference between equations (27) and (29) measures the variation of the y's that can be attributed to x. This value divided by equation (27) gives the proportion of the total value of the y's, or dependent variable, that can be attributed to the relationship with x and is called the coefficient of determination. The square root is called the coefficient of correlation with the sign of this being the same as that of the coefficient, b, in the equation of the least-squares line. These equations are as follows:

$$r^2 = \frac{\sum (y_i - \bar{y})^2 - \sum (y_i - \hat{y})^2}{\sum (y_i - \bar{y})^2} \quad (30)$$

and

$$r = \sqrt{\frac{\sum (y_i - \bar{y})^2 - \sum (y_i - \hat{y})^2}{\sum (y_i - \bar{y})^2}} \quad (31)$$

where r^2 = the coefficient of determination
 r = the coefficient of correlation.

The value of r is the most widely used measure of the strength of the linear relationship between two variables. It indicates the goodness of fit of a line or curve fitted by the method of least squares and this, in turn, tells whether or not it is reasonable to say that a linear relationship (correlation) exists between the dependent and independent variables.

IV. EXPERIMENTAL

Data for this study came from a Department of Transportation (DOT) report dealing with the renovation of shower wastewater.¹⁷ The purpose of the DOT report was to evaluate the effectiveness of ultrafiltration for the renovation of shower wastewater. Different membranes and membrane configurations were utilized on the various treatment systems.

9. Membrane Configuration. The current study evaluated two different systems using two different membranes in two different membrane configurations. These membrane configurations were hollow-fiber and spiral-wound. Both configurations employ minimal channel height which according to equations (5) and (6) increases the mass-transfer coefficient.

The hollow-fiber membrane module contains 660 fibers of 0.045-inch bore diameter. Each fiber consists of a copolymer support with the noncellulosic membrane approximately 10.0 microns in thickness coated on the inside of this support (Figure 4). The fibers are encapsulated at both ends in a 3-inch-diameter by 25-inch-long, plastic cartridge. An end view of the cartridge is shown in Figure 5. The total membrane area is 15 square feet. The feed stream of raw wastewater flows through the inside of the fibers, and the permeate collects in the shell.

The spiral-wound membrane consists of a sheet 22 inches wide with a support backing and 0.030-inch-thick vexar spacer material. This entire system is then rolled in a jelly roll fashion around a permeate collection tube. Wastewater passes through the channel made by the vexar spacer material which also serves as a turbulence promoter. The permeate passes through the membrane and is channeled by the support material to the permeate collection tube. Wastewater, called waste brine, exits the end of the channel made by the vexar spacer material. The module contains approximately 30 square feet of membrane area. End and side views of the module are shown in Figure 6.

10. System Description. A simplified flow diagram of the hollow-fiber system operated in batch mode is shown in Figure 7. The wastewater is pumped from a feed tank through a bag prefilter. The ultrafiltration system is operated at a pressure of approximately 15 psig and an influent flow rate of 16 gallons per minute at a velocity of 6 feet per second. While permeate is collected in the shell of the module, the concentrate is recirculated to the feed tank. The system also had the capability of being

¹⁷ D. S. Lent, "Renovation of Waste Shower Water by Membrane Filtration," Interim Report, U.S. Department of Transportation (1977).

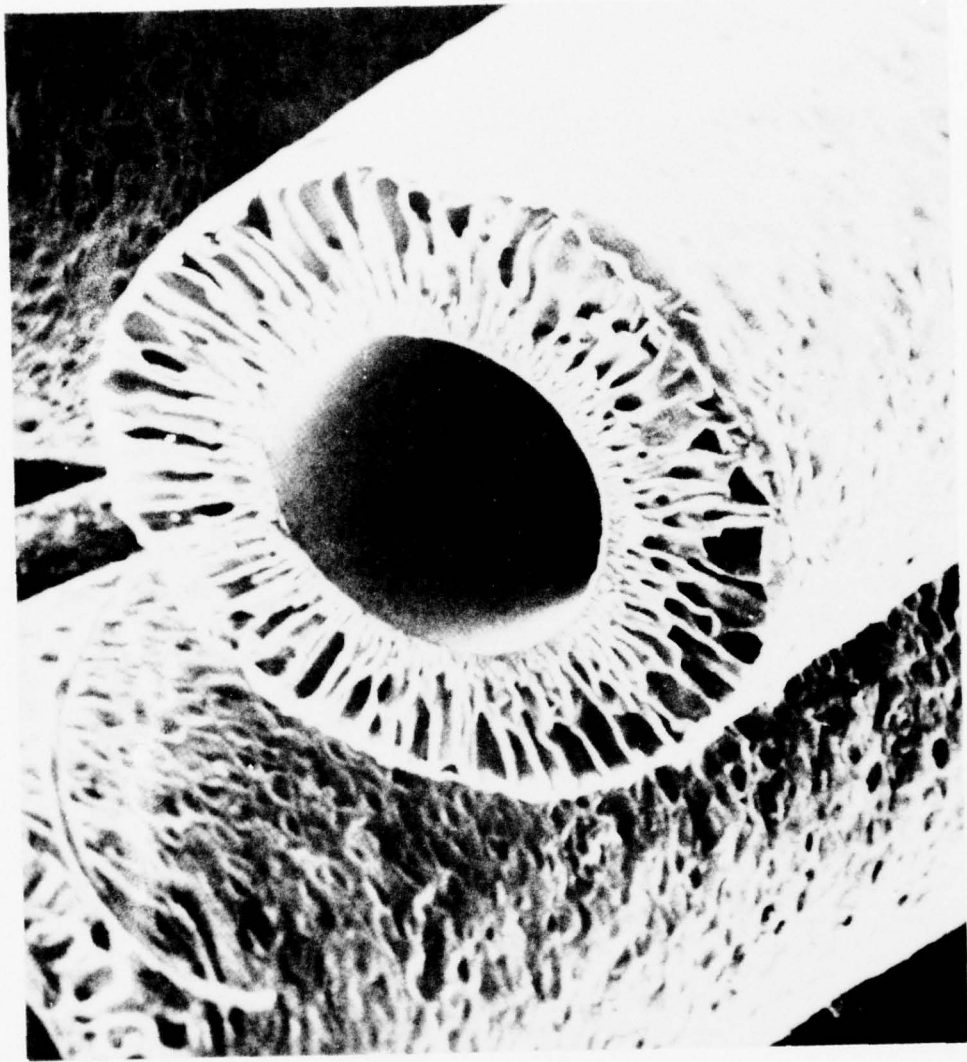

Figure 4. Photomicrograph of hollow fiber showing membrane coated on the inside of a porous support.

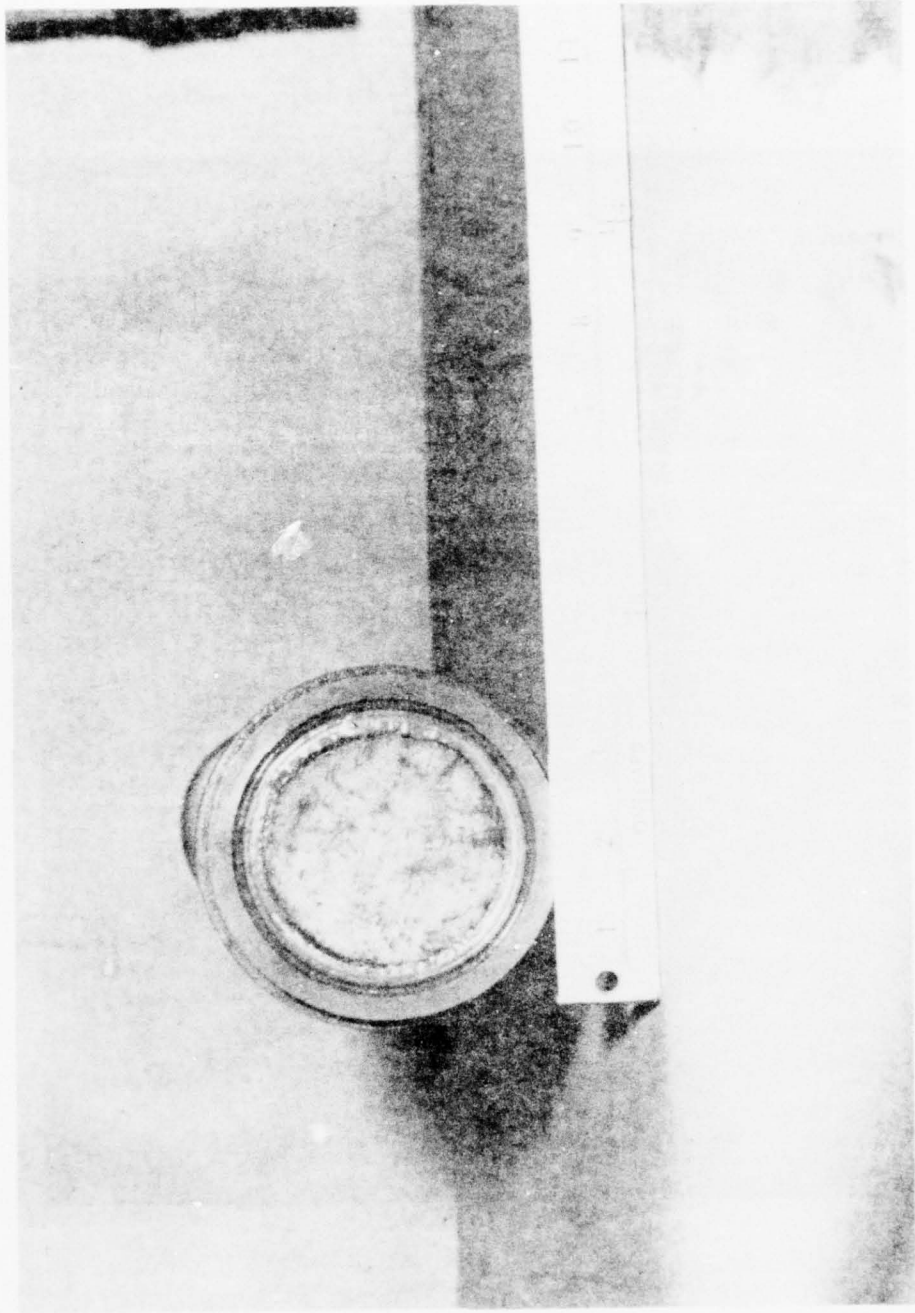

Figure 5. Hollow-fiber ultrafiltration membrane module (end view).

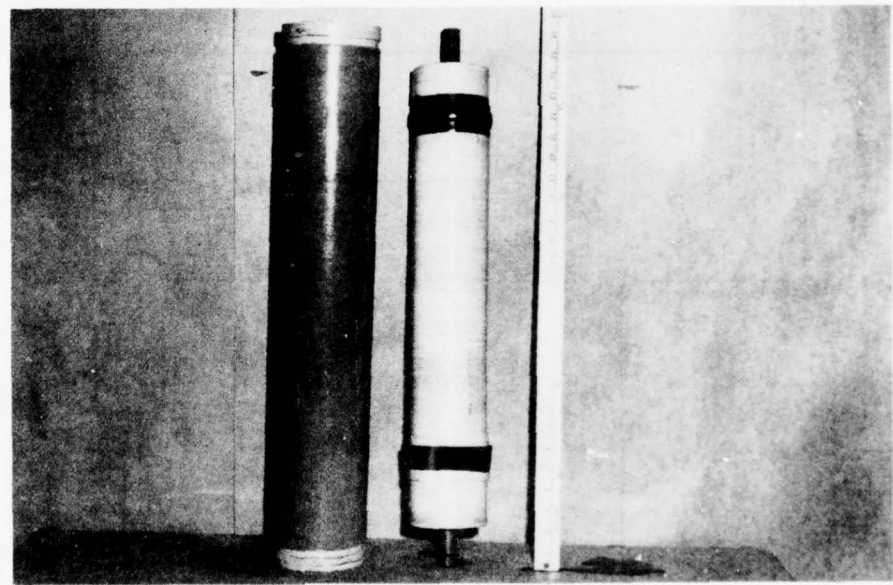
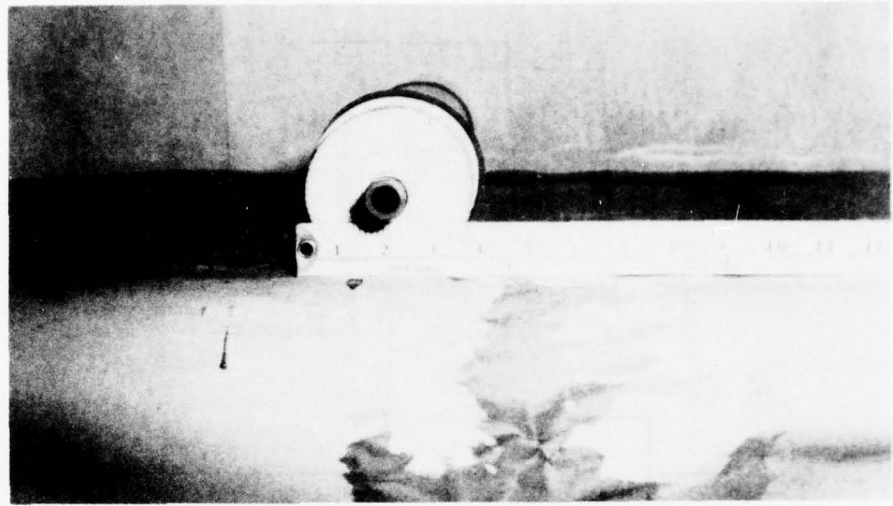

Figure 6. Spiral-wound ultrafiltration membrane module (end and side views).

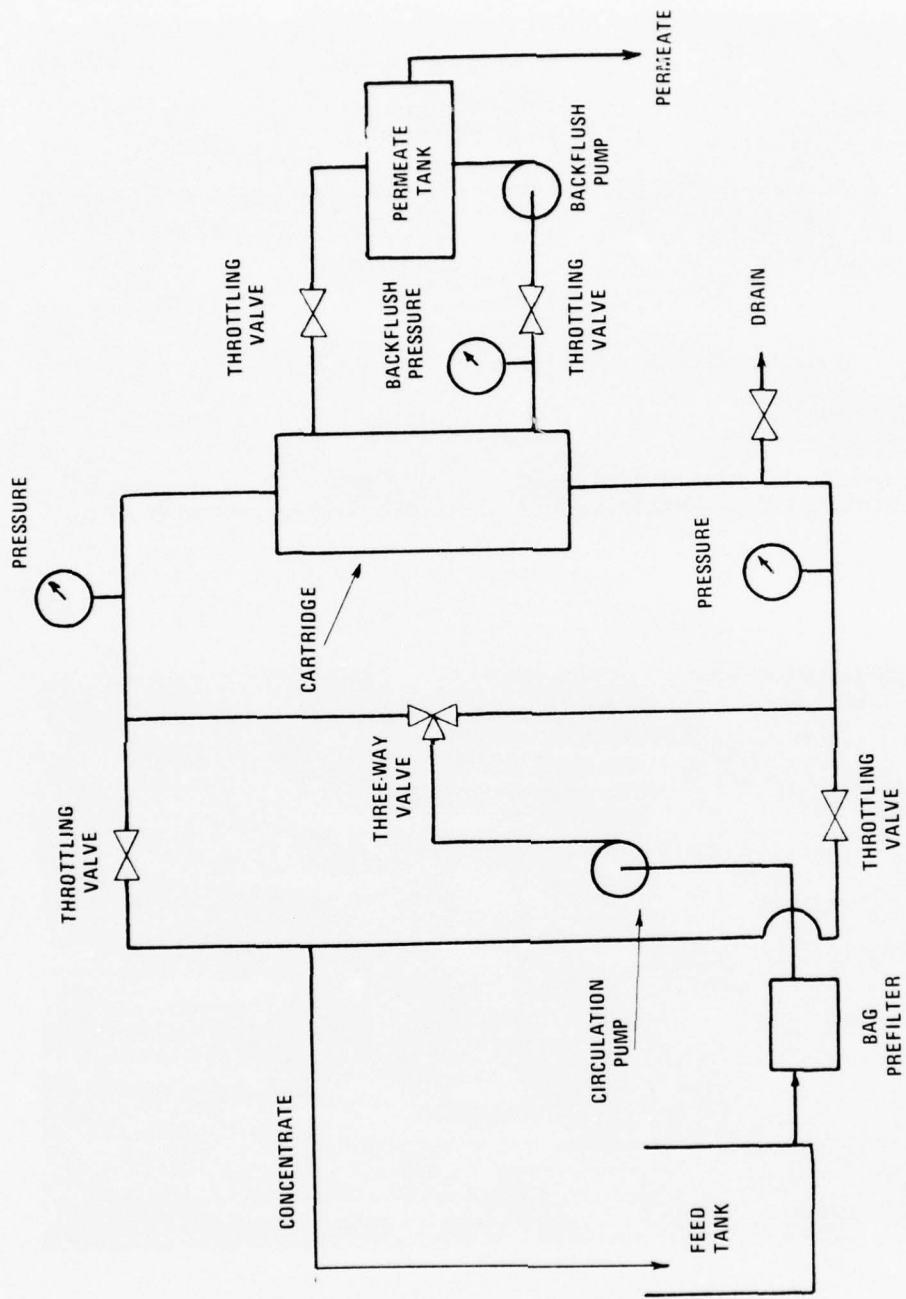

Figure 7. Flow diagram of the hollow-fiber system.

backflushed which allows the permeate to be pumped from the outside of the fiber to the inside, thus displacing any gel layer buildup on the membrane surface.

Daily operation consisted of 6 to 8 hours of continuous operation. Following the end of each day's run, the system was backflushed with about 20 gallons of permeate. On the following day, the direction of flow through the cartridge was reversed, thus eliminating any buildup of particulate material at the head or entrance of the membrane module. The system concentrates a tank of waste to about 15 percent of its original volume. The tank is then dumped and refilled with fresh wastewater.

A simplified flow diagram of the system with the spiral-wound membrane configuration operated in feed and bleed mode is shown in Figure 8. Wastewater is pumped through two prefilters into the circulation pump which maintains the velocity in the circulation loop. Within the circulation loop, two membrane cartridges are connected in series. The flow rate in the loop is 10 to 15 gallons per minute. Concentrate from within the circulation loop is purged via a solenoid valve operated periodically to maintain the desired degree of concentration in the loop.

This system was also operated 6 to 8 hours daily. The degree of concentration maintained in the loop is approximately 98 percent.

11. Data Analysis. Two hundred and twenty-two hours of operational data for the hollow-fiber system and 118 hours of data for the spiral-wound system were analyzed. Data analysis was then performed on the first 118 hours of data from the hollow-fiber system to give an equal time base for system comparison. The data for the hollow-fiber system was then analyzed on a daily basis because at the end of each day's run the system was backflushed or cleaned causing a significant increase in permeate production.

The data analysis consists of first, second, and third-order polynomial curve fits and an exponential curve fit. The analysis was performed on a Control Data Corporation 6600 Computer using a Tektronix 4014 Graphics Terminal. The analysis consists of a scatter gram plot of the data, a curve generated to best fit the data, the equation of the curve, and the square of the multiple-correlation coefficient.

V. DISCUSSION

12. Analysis of Results. Experimental values used in this study are shown in Appendix A. The computer program used for the data analysis is shown in Appendix B. Table 1 gives the coefficients of determination for various orders of fit. Table 2 gives the coefficients of determination for the time periods between backflushes for the hollow-fiber system.

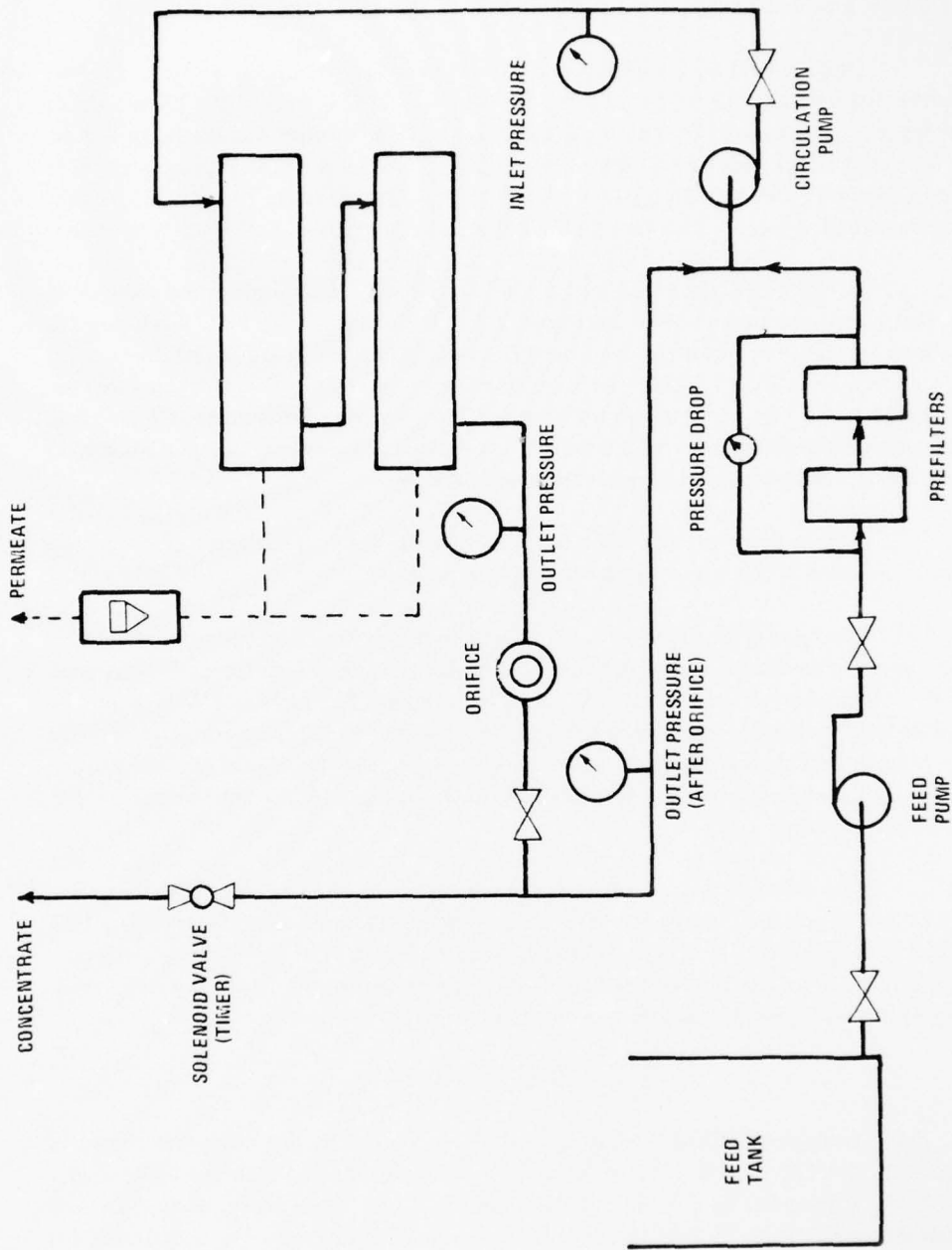

Figure 8. Flow diagram of the spiral-wound system.

Table 1. Coefficients of Determination for Various Orders of Fit

System	Order of Fit			
	1st	2nd	3rd	L
Hollow-Fiber, All (222 Hr)	.026	.201	.302	.015
Hollow-Fiber, Part (118 Hr)	.350	.514	.732	.415
Vexar Spiral- Wound (118 Hr)	.501	.837	.944	.677

Results of the runs performed on the total data for both systems are shown in Appendix C along with the results for 118 hours of operation on the hollow-fiber system.

Appendix D contains the daily, segmented, or between-backflushing, data for the hollow-fiber system. Appendix E contains segmented, fitted data for the spiral-wound system.

Table 1 shows that the best curve fits are obtained with third-order polynomials. Thus, the general, best-fit equation is of the form $Y = a x^3 + b x^2 + c x + d$. This is further demonstrated in Table 2 where once again third-order polynomials give the best fit. The trend for best fits shows that second-order fits follow in fitting the data, followed by exponential fits, followed by a first-order, or linear, fit.

Examination of the graphs for the total data in Appendix C, however, shows that the curves generated by second- and third-order polynomials describe unrealistic results. The second-order fits in all cases show a maximum, a minimum, and then a maximum. This contradicts the phenomenon of concentration polarization described earlier in that the boundary-layer accumulation would have to increase to a point (causing a decrease in flux) then decrease at approximately the same rate (causing an increase in flux).

The third-order fits go one step further from the maximum/minimum/maximum and add a minimum. It is possible for the flux to decrease and increase; however, the rate of increase is always rapid and is achieved when the boundary gel layer is suddenly removed either naturally or by cleaning.

The empirical model, therefore, would be an equation of high order; thus, by having the predicted equation oscillate above and below the data enough times, the

Table 2. Coefficients of Determination for Time Periods
Between Backflushings for the Hollow-Fiber System

Segment	Order of Fit			
	1st	2nd	3rd	L
0 to 8.6	.720	.927	.972	.827
8.6 to 15.4	.830	.983	.989	.861
15.4 to 19.6	.796	.923	.925	.792
20.2 to 44.2	.870	.917	.958	.901
44.9 to 48.9	.453	.555	.599	.456
52.2 to 60.0	.779	.926	.932	.782
59.9 to 90.7	.867	.923	.973	.910
91.4 to 95.3	.657	.849	.915	.710
98.4 to 100.3	.997	1.000	1.000	1.000
101.5 to 104.9	.808	.946	.994	.863
106.1 to 114.1	.480	.573	.584	.555
115.6 to 122.9	.004	.020	.234	.007
124.0 to 130.1	.697	.876	.880	.684
130.6 to 136.9	.894	.978	.978	.908
137.9 to 145.1	.781	.943	.945	.785
145.1 to 150.4	.885	.887	.931	.898
150.6 to 157.3	.654	.896	.929	.682
157.7 to 164.8	.291	.782	.896	.286
164.8 to 170.5	.456	.506	.593	.455
171.3 to 176.1	.802	.843	.971	.815
176.3 to 184.5	.954	.967	.971	.969
185.3 to 190.9	.732	.734	.895	.721
192.3 to 199.6	.580	.940	.995	.585
200.2 to 207.6	.213	.213	.834	.207
208.1 to 215.7	.539	.769	.831	.543
216.5 to 222.4	.840	.851	.923	.723

equation very nearly fits the line. However, the problems with this would be the large number of constants needed to define the equation and the computation of the constants. Therefore, without the data, prediction of any results would be purely arbitrary.

13. Proposition of Theory. Consideration of the actual system dictates that initially or early in the run the system is at unsteady state. This is true because at time zero there is no boundary layer present which is evident by observing the initial, rapid rate of flux decline which is proportional to the rate of buildup of boundary layer.

This buildup is directly proportional to the solute concentration because almost all of the solute removed from the waste stream is forming the boundary layer.

As the boundary layer develops, the transport of material from the boundary layer to the bulk solution begins to be the controlling factor for permeate production. The amount of this lateral diffusion is more proportional to the system's design and operational parameters than to the solute concentration. This, of course, is true only under the assumption that permeate production is proportional to the amount of boundary layer.

14. Proposition of the Model. Under this premise, a two-part model was tried. The first part would cover the unsteady state condition of rapid flux decline and the second part would cover the condition where diffusion away from the membrane is the controlling factor. A more detailed approach would also consider the transition period where permeate production is a function of both parts. However, since specific boundaries for this transition state would be very hard to establish, the two-part model was chosen.

The general procedure for using the model is to visually inspect the complete plots of the data and the data itself. Then, the data is separated into two portions which tentatively satisfy the conditions of the model and perform curve fits on both portions of the data.

15. Application of the Model to the Hollow-Fiber System. Examination of the plots and data of the hollow-fiber system in Appendices A and C fails to reveal the two parts described earlier. What the examination does reveal, however, are many segments, each exhibiting a rapid rate of flux decline with varying degrees of flux recovery between each segment. Therefore, it appears that this system's data does not fit the model.

However, when the daily operation of the system is considered, it is clear that the data does fit the model. This is true because each day the system was back-flushed. This operation consisted of pumping permeate backward through the membrane thus removing the boundary layer. Since the boundary layer was removed each day, it never had a chance to build up enough to become the controlling factor in permeate production. Therefore, the system was always in an unsteady state condition, and only the first portion of the model should be applied to the system's data. Verification of the model consisted of segmenting the data into time periods between back-flushes and then performing curve fits. The coefficients of determination for the fitted curves are shown in Table 2, and the actual, fitted curves are graphically shown in Appendix D.

A comparison of the coefficients of determination from the entire run and the first 118 hours of the run with the coefficients from the segmented data shows much better correlation with the segmented data. Review of the second- and third-order plots in Appendix D also shows these plots to be somewhat unrealistic because of their cyclic nature. First-order fits can also be eliminated since the trend in all cases is never linear. Therefore, the exponential fit best fits the segmented data for the hollow-fiber system. The coefficients as well as the coefficients of determination for the various segmented sections are given in Table 3.

Table 3. Exponential-Curve-Fit Coefficients and Coefficients of Determination for the Hollow-Fiber System

Segment	a	b	r ²
0 - 8.6	79.0	-0.104	.827
8.6 - 15.4	102	-0.070	.861
15.4 - 19.6	172	-0.098	.792
20.2 - 44.2	43.9	-0.024	.901
44.9 - 48.9	60.6	-0.022	.456
52.2 - 60.0	56.0	-0.018	.782
59.9 - 90.7	51.1	-0.014	.910
91.4 - 95.3	1.35 x 10 ⁴	-0.063	.710
98.4 - 100.3	2.47 x 10 ¹¹	-0.230	1.000
101.5 - 104.9	1.42 x 10 ⁸	-0.151	.863
106.1 - 114.1	3.15 x 10 ⁴	-0.069	.555
115.6 - 122.9	18.1	-0.003	.007
124.0 - 130.1	1.61 x 10 ⁷	-0.109	.684
130.6 - 136.9	1.74 x 10 ⁴	-0.050	.908
137.9 - 145.1	3.28 x 10 ³	-0.035	.785
145.1 - 150.4	4.40 x 10 ⁴	-0.201	.898
150.6 - 157.3	3.87 x 10 ⁷	-0.0932	.682
157.7 - 164.8	174	-0.0115	.286
164.8 - 170.5	169	-0.0212	.455
171.3 - 176.1	1.28 x 10 ³	-0.0225	.815
176.3 - 184.5	3.09 x 10 ⁵	-0.0504	.969
185.3 - 190.9	7.12 x 10 ⁷	-0.0800	.721
192.3 - 199.6	1.67 x 10 ⁻⁷	-0.0936	.585
200.2 - 207.6	417	-0.0124	.207
208.1 - 215.7	4.11 x 10 ⁴	-0.0341	.543
216.5 - 222.4	1.85 x 10 ¹⁷	-0.165	.723

where: $y = ae^{bx}$ and r^2 = coefficient of determination.

16. **Application of the Model to the Spiral-Wound System.** Examination of the graphs in Appendix C for this system reveals an initial, rapid rate of flux decline followed by an almost linear leveling out of the data. Therefore, this data appears to fit the proposed theory rather well. To test this, the data was segmented into two sections, and curve fits were performed on each section. The first segment was 531.9 to 555.3 and the second segment, the remainder of the data, 556.2 to 649.6. This was called Group 1 on which first-order and exponential curve fits were run. This process was continued for Groups 2 and 3, each of which segmented the data in a different place. These curve fits are shown in Appendix E. The resulting coefficients and coefficients of determination for the fits are shown in Table 4.

Table 4. First-Order and Exponential-Curve-Fit Coefficients and Coefficients of Determination for the Spiral-Wound System

Group No.	Segment	1st Order			Exponential		
		a	b	r ²	*a	b	r ²
1	531.9 - 555.3	-.13	76.8	.910	3.4×10^{14}	-.060	.952
2	531.9 - 560.2	-.12	66.2	.900	6.8×10^{13}	-.057	.963
3	531.9 - 575.0	-7.3×10^{-2}	42.3	.800	2.5×10^{10}	-.043	.909
1	556.2 - 649.6	-4.52×10^{-3}	3.29	.543	38.0	-0.007	.535
2	561.1 - 649.6	-3.70×10^{-3}	2.77	.480	19.7	-0.006	.463
3	576.0 - 649.6	-6.30×10^{-4}	.864	.067	1.02	-0.001	.057

Where: $y = ax + b$ for first order
 $y = ae^{bx}$ for exponential
 r^2 = coefficient of determination
 * calculated using Hewlett Packard model 65 calculator with StatPack Exponential Curve Fit Program

Group 2 data for the initial, or unsteady state, gives the best fit. It is no surprise that the best fit comes from the exponential equation with a rather high coefficient of determination. As for the steady state, or latter portion, of the data, the optimum tends to be closer to Group 1. In this case, the first-order fit gives a better fit than the exponential fit. Examination of the daily operation data shows essentially constant daily permeate production; however, on different days this figure fluctuates. The coefficient of determination is low and appears to get worse as less data is considered.

The reason for this can be seen by comparing the curve fits for the total data found in Appendix C and the curve fits of the segmented data. Visual examination of the 560- to 650-hour range in the graph of the total data on this system reveals an almost linear area of the curve. Compare this with the 561.1- to 649.6-hour segmented

graph found in Appendix E. Since the permeate production is much less variable here than for the whole system, the y axis is greatly expanded here as compared to the whole system. Thus, the amount of error is expanded as less data is considered not only in the visual presentation but also as witnessed in the low value for the coefficient of determination.

The apparent discrepancy between Group 2 data best fitting the unsteady state condition and Group 1 data best fitting the steady state condition can be partly attributed to Group 1's steady state data being more voluminous and, therefore, having a better coefficient of determination. However, the main reason for the discrepancy could be the definition of the boundary conditions for steady and unsteady states. In actuality, the boundary conditions probably lie between the boundary conditions defined as Group 1 and those defined as Group 2; and, second, it is doubtful that there is a discrete boundary between the two states resulting in a third, or transition, state as pointed out earlier.

VI. CONCLUSIONS

17. **Conclusions.** Based on the data, this study concludes that:

- a. A single, empirical equation cannot describe permeate production by ultrafiltration of shower wastewater.
- b. A model based on unsteady and steady state phenomena of concentration polarization can empirically describe the ultrafiltration process.
- c. The hollow-fiber system can be described by a single, empirical equation of exponential order because the system as studied was never allowed to reach steady state. Therefore, the unsteady state equation described the system's operation.
- d. The spiral-wound membrane system can be described empirically by an exponential equation during the boundary layer formation and by a linear equation during steady state operation.

APPENDIX A

DATA

The following pages are a computer listing of the data. Line numbers 100 through 2010 are the data from the hollow-fiber system. The first number is the line number and is followed by an equal sign. The second number is the time factor expressed in hours, and the third number is the flux expressed in gallons per square feet of membrane area per day. After Line 2010, the line numbers begin again at 100 and continue through 1380. This is the data from the spiral-wound system. Time, again, is expressed in hours; however, it is not normalized and, therefore, begins at 531.9. Flux, this time, is expressed in gallons per minute.

BEST AVAILABLE COPY

L,100 830	100-0.0	101.46	460-53.4	22.06
	110-0.9	68.98	470-54.3	21.30
	120-2.4	55.80	480-55.1	20.8
	130-3.3	51.24	490-55.9	19.78
	140-4.4	43.62	500-57.6	20.30
	150-5.2	43.62	510-58.4	20.04
	160-6.4	40.58	520-60.	19.78
	170-8.6	38.04	530-59.9	25.36
	180-8.6	59.6	540-60.9	23.08
	190-8.9	58.34	550-61.9	22.06
	200-9.9	48.7	560-62.6	20.04
	210-10.9	43.62	570-63.2	20.04
	220-11.9	42.62	580-64.7	19.52
	230-12.9	38.56	590-65.6	19.02
	240-13.9	38.04	600-67.1	18.52
	250-15.4	38.04	610-83.5	16.48
	260-15.4	40.58	620-84.8	14.96
	270-15.9	35.	630-85.7	15.48
	280-17.4	31.46	640-86.3	15.22
	290-18.2	25.36	650-87.2	14.72
	300-19.6	27.4	660-88.8	14.72
	310-20.2	30.44	670-89.5	14.72
	320-21.4	25.36	680-90.7	14.46
	330-22.1	25.88	690-91.4	50.72
	340-23.2	25.36	700-92.2	38.56
	350-24.3	25.36	710-93.4	38.56
	360-25.4	22.82	720-94.1	32.98
	370-26.2	22.32	730-95.3	33.98
	380-43.2	17.76	740-98.	30.94
	390-44.2	14.2	750-98.4	38.04
	400-44.9	22.32	760-99.1	32.46
	410-46.1	22.32	770-100.3	24.6
	420-47.3	22.82	780-101.5	36.02
	430-48.	20.30	790-102.	27.9
	440-48.9	20.80	800-103.	23.34
	450-52.2	22.82	810-104.1	21.82
			820-104.9	20.3
			830-106.1	21.56

BEST AVAILABLE COPY

L.840 1570			
840-107.4	27.9	1200-142.9	21.82
850-107.6	16.24	1210-143.9	20.3
860-108.7	15.48	1220-145.1	22.06
870-109.7	14.72	1230-145.1	86.24
880-110.6	13.7	1240-145.9	80.14
890-111.9	13.7	1250-147.2	76.72
900-112.9	13.7	1260-148.	44.12
910-114.1	13.7	1270-149.1	39.06
920-115.6	14.2	1280-150.4	32.98
930-116.4	12.68	1290-150.6	35.5
940-117.6	12.42	1300-151.1	36.02
950-117.9	12.42	1310-152.3	21.3
960-119.	14.2	1320-153.5	20.66
970-120.9	12.18	1330-154.1	20.3
980-122.2	14.96	1340-154.9	20.04
990-122.9	11.92	1350-156.2	19.52
1000-124.	24.08	1360-157.3	19.28
1010-124.9	21.82	1370-157.7	30.44
1020-125.9	14.2	1380-158.1	28.4
1030-126.9	16.74	1390-158.9	26.64
1040-127.9	12.7	1400-160.1	26.12
1050-128.9	10.9	1410-161.5	26.88
1060-130.1	13.94	1420-162.	25.88
1070-130.6	27.9	1430-162.9	26.38
1080-131.1	25.88	1440-164.8	27.4
1090-132.	24.34	1450-164.8	22.82
1100-132.9	23.58	1460-165.2	23.08
1110-134.2	21.56	1470-166.6	23.34
1120-134.9	20.3	1480-166.9	21.3
1130-136.	20.8	1490-167.9	21.82
1140-136.9	20.3	1500-169.6	21.3
1150-137.9	27.4	1510-170.5	21.82
1160-138.9	26.12	1520-171.3	27.88
1170-140.	23.34	1530-171.9	25.88
1180-140.9	22.82	1540-173.9	25.36
1190-142.1	22.32	1550-175.2	24.98
		1560-176.1	24.34
		1570-176.3	43.62

BEST AVAILABLE COPY

1940-215.7 27.64
1950-216.5 48.2
1960-217.4 39.56
1970-218.4 39.06
1980-219.5 32.22
1990-220.2 30.44
2000-221.5 31.46
2010-222.4 13.18

..

L, 1580 2050

1580-178.3	36.52
1590-179.2	37.04
1600-179.9	36.02
1610-181.	33.98
1620-182.3	30.94
1630-182.9	30.44
1640-184.5	28.4
1650-185.3	26.38
1660-185.9	25.88
1670-186.9	18.76
1680-187.9	20.3
1690-189.2	21.3
1700-190.1	20.8
1710-190.9	16.48
1720-192.	13.18
1730-192.3	12.68
1740-193.1	13.18
1750-195.2	13.7
1760-195.9	12.68
1770-197.	13.18
1780-199.6	28.92
1790-200.2	31.7
1800-201.	37.28
1810-202.	36.26
1820-203.1	34.5
1830-204.3	31.7
1840-205.1	31.46
1850-205.9	31.2
1860-207.6	33.22
1870-208.1	38.42
1880-209.4	30.44
1890-210.2	33.48
1900-211.3	27.4
1910-212.1	27.64
1920-213.2	28.92
1930-214.2	29.16

BEST AVAILABLE COPY

1200- .5000
1210- 631.8000
1220- 632.6000
1230- 633.6000
1240- 634.4000
1250- 635.5000
1260- 636.6000
1270- 637.4000
1280- 638.5000
1290- 639.3000
1300- 640.8000
1310- 641.7000
1320- 642.4000
1330- 643.6000
1340- 644.7000
1350- 645.7000
1360- 646.5000
1370- 647.5000
1380- 648.5000
1390- 649.6000

..

L.840 1570
840- 600.7000 .5000
850- 601.6000 .5000
860- 601.7000 .5000
870- 602.6000 .5000
880- 603.7000 .5000
890- 604.6000 .5000
900- 605.6000 .5000
910- 606.6000 .5000
920- 607.6000 .5000
930- 608.7000 .5000
940- 608.9000 .5000
950- 609.7000 .5000
960- 610.7000 .4000
970- 611.6000 .4000
980- 612.6000 .4000
990- 613.6000 .4000
1000- 614.6000 .4000
1010- 615.6000 .4000
1020- 616.3000 .4000
1030- 616.4000 .4000
1040- 617.4000 .4000
1050- 618.2000 .4000
1060- 619.4000 .4000
1070- 620.4000 .4000
1080- 621.4000 .4000
1090- 622.4000 .4000
1100- 623.2000 .4000
1110- 624.4000 .4000
1120- 624.5000 .4000
1130- 625.5000 .5000
1140- 626.6000 .5000
1150- 627.5000 .5000
1160- 628.5000 .5000
1170- 629.4000 .5000
1180- 630.5000 .5000
1190- 631.5000 .5000

APPENDIX B

COMPUTER PROGRAM

An interactive computer program was written in Fortran IV language for performing the curve fits. The subroutines for the graphics portion of the program are from the Tektronix Advanced Graphics Package. These include INITT, TERM, BINITT, MMX, BELL, SCURSR, DLIMX, DLIMY, ERASE, LINE, SYMBL, CHECK, DSPLAY, CPLOT, MOVABS, HSTRIN, VLABEL, AMMODE, and FINITT. The program was run on a Control Data Corporation 6000 Computer using a Tektronix 4014 Graphics Terminal.

The data was stored on a permanent disk file. The context editor was used to segment the data. This data was then saved as TAPE 1 without line numbers. TAPE 1 was re-wound and the compiled version of the program was executed. Alternatively, data could be entered directly from the terminal by connecting TAPE 1 and entering the data when directed by the computer.

Upon execution, a scatter gram of zero-order fit is plotted. Options of E, R, L, or N can then be entered as explained in line numbers 580 through 610 for the graphical representation desired. The output consists of the order of fit, graphical data presentation, the titled curve, the equation of the curve, and the coefficient of determination expressed as SQ MULT CORR COEFF IS. In some cases, a coefficient of the equation is given by * * * * * indicating insufficient storage capacity for the size number stored. The order of fit is not shown on the graphs because of margin limitations.

BEST AVAILABLE COPY

```
L 100 440
..
PROGRAM CURFIT(TAPE1, INPUT, OUTPUT, TAPES-INPUT, TAPE6-OUTPUT)
DIMENSION X(201), Y(201), YC(201), RES(201), C(11), SSR(5)
DIMENSION ITIT(12), IHT(9), IUT(5), YL(201)
DIMENSION FMT(6), JOD(11)
DATA FMT/7H(X Y= X, 1H , 10H(F8.2 , X X, 9H X, 3HX , , 9H11, X + X
10.4)/
DATA ITIT/11, 117B, 122B, 104B, 105B, 122B, 40B, 60B, 40B,
1 106B, 111B, 124B/
DATA IHT/8, 103B, 125B, 115B, 40B, 124B, 111B, 115B, 105B/
DATA IUT/4, 106B, 114B, 125B, 130B/
DATA IASE/105B/, IASR/122B/, IASL/114B/
DATA C/11X./
CALL CONNOC(5, 2)
CALL CONNOC(6, 2)
CALL INITT(30)
CALL TERM(3, 1024)
CALL BINITT

INPUT THE DATA

CALL ERASE
I=0
CALL CONNOC(6, 0)
WRITE(6, 11)
FORMAT(X INPUT THE DATA)
CALL CONNOC(6, 2)
READ(1, 10) X(I+2), Y(I+2)
FORMAT(2F10.4)
IF(EOF(1).NE.0) GO TO 20
I=I+1
IF(I.GE.200) GO TO 20
GO TO 9
IF(I.LT.2) GO TO 99
X(1)=Y(1)=YC(1)=RES(1)=YL(1)=I
440=C
```

BEST AVAILABLE COPY

L 450 800

..

```
450-C      DRAW THE DATA FIRST
460-C
470-200    CONTINUE
480-      IOPT=0
490-      CALL MINMX(Y, YMIN, YMAX)
500-      GO TO 31
510-C
520-C      GET THE OPTION
530-C
540-21     CALL BELL
550-      CALL SCURSR(IOPT, IX, IV)
560-C
570-C      TEST FOR OPTIONS ALLOWED
580-C      E END
590-C      R READ NEW DATA
600-C      L LOG FIT
610-C      N ORDER OF POLYNOMIAL TO FIT
620-C
630-      IF(IOPT.EQ.IASE) GO TO 99
640-      IF(IOPT.EQ.IASR) GO TO 8
650-      IF(IOPT.NE.IASL) GO TO 22
660-C
670-C      LOG FIT SECTION
680-C
690-      DO 23 J=1, I
700-23     YL(J+1)=ALOG(Y(J+1))
710-      CALL POLYFIT(X(2), YL(2), I, 1, YC(2), RES(2), C, SSR)
720-      DO 24 J=1, I
730-24     YC(J+1)=EXP(YC(J+1))
740-      IOPT=IOPT-600
750-      GO TO 25
760-22     CONTINUE
770-      IOPT=IOPT-600
780-      IF(IOPT.LT.0) .OR. IOPT .GT. 9) GO TO 99
790-      IF(IOPT.EQ.0) GO TO 200
800-C
```

BEST AVAILABLE COPY

```
L 810 1140
      810-C
      820-C
      830-
      840-25
      850-
      860-
      870-
      880-
      890-
      900-30
      910-C
      920-C
      930-C
      940-31
      950-
      960-
      970-C
      980-C
      990-C
     1000-
     1010-
     1020-
     1030-
     1040-
     1050-C
     1060-C
     1070-C
     1080-
     1090-
     1100-
     1110-
     1120-C
     1130-C
     1140-C

      VALID CALL TO DO THE FIT
      CALL POLYFIT(X(2),Y(2),I,IOPT,YC(2),RES(2),C,SSR)
      CONTINUE
      YMIN=AMINI(Y(2),YC(2))
      YMAX=AMAXI(Y(2),YC(2))
      DO 30 J=2,I
      IF(AMINI(Y(J+1),YC(J+1)).LT.YMIN) YMIN=AMINI(Y(J+1),YC(J+1))
      IF(AMAXI(Y(J+1),YC(J+1)).GT.YMAX) YMAX=AMAXI(Y(J+1),YC(J+1))
      CONTINUE
      DRAW THE GRAPH
      CONTINUE
      CALL DLIMX(X(2),X(I+1))
      CALL DLIMY(YMIN,YMAX)
      PLOT EXPR DATA
      CALL ERASE
      CALL LINE(0)
      CALL SYMBL(2)
      CALL CHECK(X,Y)
      CALL DISPLAY(X,Y)
      PLOT THE CURVE
      IF(IOPT.EQ.0) GO TO 32
      CALL SYMBL(0)
      CALL LINE(1)
      CALL CPLOT(X,YC)
      ADD THE TITLES
```

BEST AVAILABLE COPY

L 1150 1470

```
1150-32 CONTINUE
1160- ITIT(8)=IOPT+600
1170- CALL MOVABS(455,750)
1180- CALL HSTRIN(ITIT)
1190- CALL MOVABS(460,50)
1200- CALL HSTRIN(IHT)
1210- CALL MOVABS(50,500)
1220- CALL VLABEL(IUT(1),IUT(2))
1230-C EQUATION PLOT
1240-C
1250-C
1260- IF(IOPT.EQ.0) GO TO 320
1270- CALL MOVABS(75,50)
1280- CALL ANMODE
1290- CALL CONNOC(6,0)
1300- IF(ITIT(8).EQ.IASL) GO TO 300
1310-C REGULAR POLYNOMIAL
1320-C
1330-C ENCODE(10,305,FMT(2))IOPT
1340- FORMAT(I10)
1350- 305 DO 330 JD=1,IOPT
1360- JOD(JD)=IOPT+1-JD
1370- 330 WRITE(6,FMT)(C(JD),JOD(JD),JD-1,IOPT),C(IOPT+1)
1380- WRITE(6,315) SSR(4)
1385- GO TO 320
1390- CONTINUE
1400- 300 LOG SECTION
1410-C C(2)=EXP(C(2))
1420-C WRITE(6,310) C(2),C(1)
1430-C WRITE(6,315) SSR(4)
1440-
1450- 310 FORMAT(X Y = X,F10.3,X EXP( X,F10.3,X X)X)
1465- 315 FORMAT( X SO MULT CORR COEF IS X,2X,F10.3)
1470- 300 CONTINUE
```

BEST AVAILABLE COPY

```
L 1480 1810
1480- CALL CONVEC(6,2)
1490- GO TO 21
1500-99 CALL FINITT(0,700)
1510- CALL DISCON(5)
1520- CALL DISCON(6)
1530- END
1540- SUBROUTINE POLYFIT(X,Y,N,M,VC,RES,C,SSR)
1550- DIMENSION A(11,12),B(20)
1560-C X,Y ARE INPUT ARRAYS
1570-C N IS THE NUMBER OF POINTS
1580-C M IS THE ORDER OF THE CURVE TO FIT
1590-C VC IS THE CALCULATED Y
1600-C RES IS THE RESIDUAL
1610-C C IS THE ARRAY OF COEFFICIENTS
1620-C SSR IS THE STATISTICS RETURN ARRAY
1630- DIMENSION X(200),Y(200),YC(200),RES(200),C(11),SSR(5)
1640- IF (N.LE.1) STOP
1650- IF (N.LE.200) GO TO 2
1660- PRINT 1100, N
1670- 1100 FORMAT(/,5X18HNUMBER OF POINTS =,I5,2X19HEXCEEDS MAX. OF 50
0/
1680- C 5X18HPROGRAM ERROR STOP)
1690- STOP 10
1700- 2 IF (M.GT.0) GO TO 3
1710- PRINT 1200, M
1720- 1200 FORMAT(/,5X8HDEGREE =,I5,9H IN ERROR/5X18HPROGRAM ERROR STO
P)
1730- STOP 20
1740- 3 IF (M.LE.10) GO TO 4
1750- PRINT 1300, M
1760- 1300 FORMAT(/,5X8HDEGREE =,I5,2X,13HREDUCED TO 10)
1770- M = 10
1780-4 CONTINUE
1790- 5 MA = M + 1
1800- MB = M + 2
1810- M2 = M + M
```

BEST AVAILABLE COPY

L 1820 2170

1820- DO 10 I = 1, M2
1830- 10 B(I) = X(1)XXI
1840- DO 20 I = 1, M2
1850- DO 20 J = 2, N
1860- 20 B(I) = B(I) + X(J)XXI
1870- A(I, MA) = N
1880- DO 30 I = 2, MA
1890- 30 A(I, MA) = B(I-1)
1900- DO 40 I = 1, MA
1910- K = I - 1
1920- DO 40 J = 2, MA
1930- L = MA - J + 1
1940- K = K + 1
1950- 40 A(I, L) = B(K)
1960- SUM = 0.0
1970- DO 50 I = 1, N
1980- 50 SUM = SUM - Y(I)
1990- DO 60 I = 1, M
2000- 60 B(I) = -Y(1)XX(1)XXI
2010- DO 70 I = 1, M
2020- DO 70 J = 2, N
2030- 70 B(I) = B(I) - Y(J)XX(J)XXI
2040- A(I, MB) = SUM
2050- DO 80 I = 2, MA
2060- 80 A(I, MB) = B(I-1)
2070- DO 100 K = 1, M
2080- L = K + 1
2090- DO 90 I = K, MA
2100- AB = A(I, K)
2110- DO 90 J = K, MB
2120- 90 A(I, J) = A(I, J)/AB
2130- DO 100 I = L, MA
2140- DO 100 J = K, MB
2150- 100 A(I, J) = A(K, J) - A(I, J)
2160- A(MA, MB) = A(MA, MB)/A(MA, MA)
2170- DO 110 I = 1, MA

BEST AVAILABLE COPY

```
L 2180 2410
2180- 110 C(I) = -A(I,MB)
2190- DO 120 J = 2,MA
2200- K = MA - J + 2
2210- L = K - 1
2220- DO 120 I = 1,L
2230- 120 C(I) = C(I) - A(I,K)*C(K)
2240- SUM = 0.0
2250- SY = 0.0
2260- SZ = 0.0
2270- DO 150 I = 1,M
2280- P = X(I)
2290- Q = PIX(I)
2300- IF(M.EQ.1) GO TO 145
2310- DO 140 J = 2,M
2320- 140 Q = PX(Q+C(J))
2330- 145 YC(I) = Q + C(MA)
2340- RES(I) = Y(I) - YC(I)
2350- SUM = SUM + RES(I)**2
2360- SY = SY + Y(I)
2370- SZ = SZ + Y(I)**2
2380- SZ = SZ - SY*SY/FLOAT(M)
2390- SSR(4) = 1.0 - SUM/SZ
2400- RETURN
2410- END
```

..

APPENDIX C

CURVE FITS FOR SYSTEM OPERATION

The first four graphs represent the total data for the hollow-fiber membrane system. The next four graphs represent the first 118 hours of operation of the hollow-fiber system. These are included for comparison of the two systems on an equal-time basis. The last four graphs represent the total data for the spiral-wound membrane system. The specific order of the graphs is first-, second-, and third-order followed by the exponential curve fit.

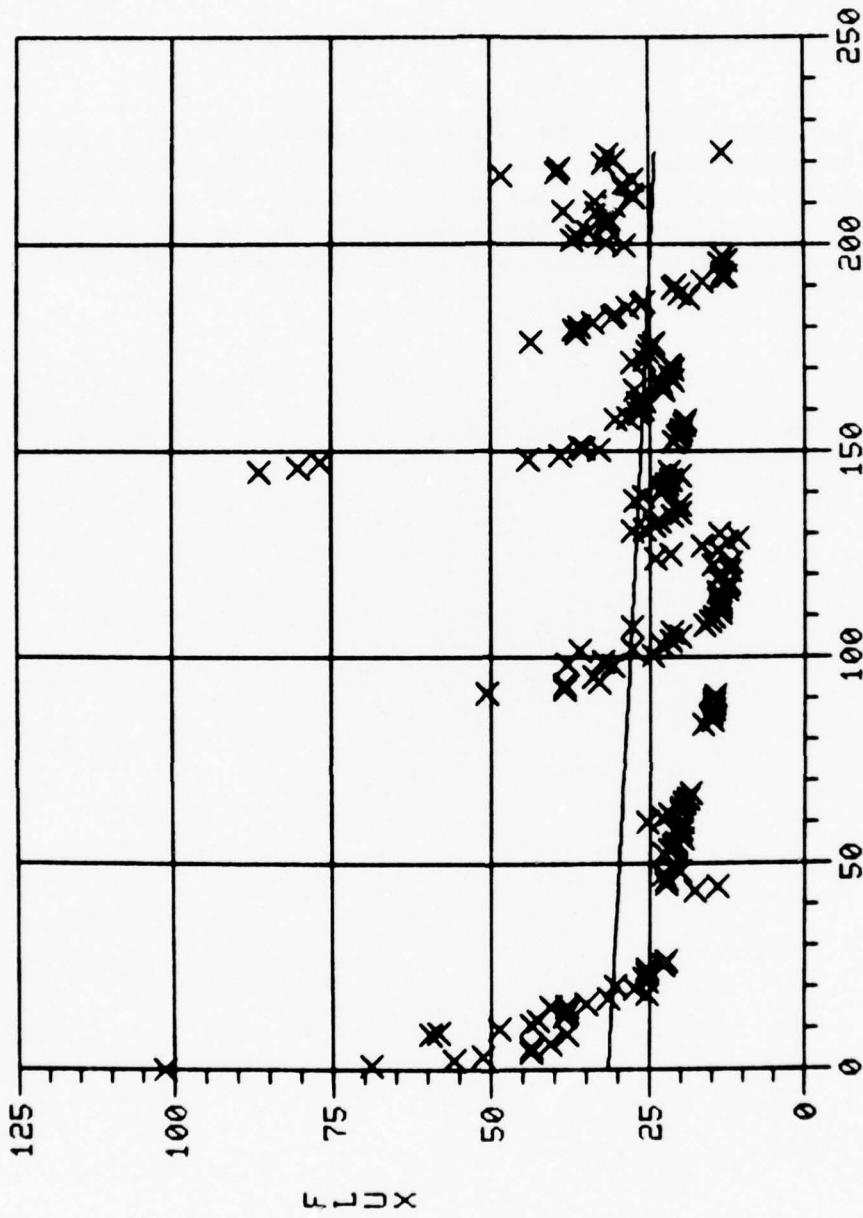

CUM TIME

Y = -.337E-01 X ** 1 + 31.5054
 SQ MULT CORR COEF IS .026

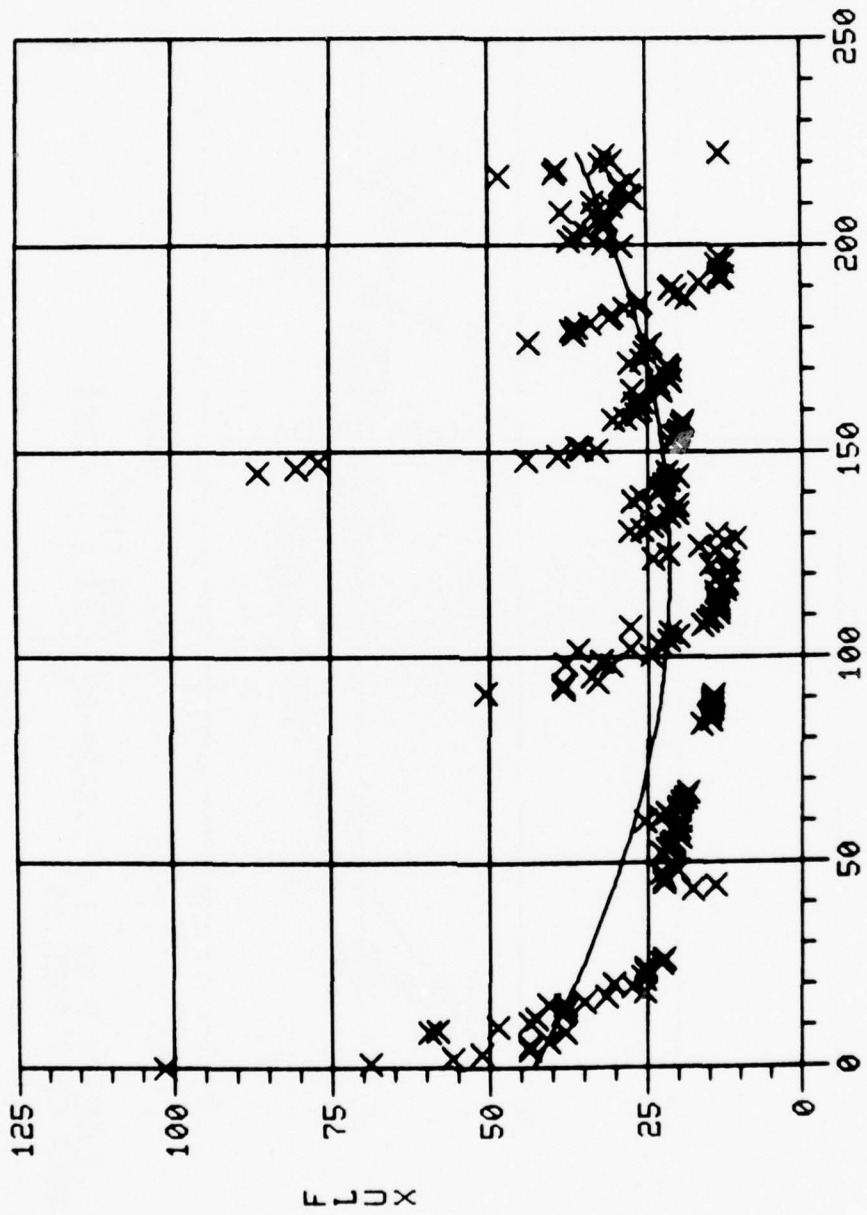

Y = .144E-02 X ** 2 + -.352 X ** 1 + 43.0663
 SQ MULT CORR COEF IS .201

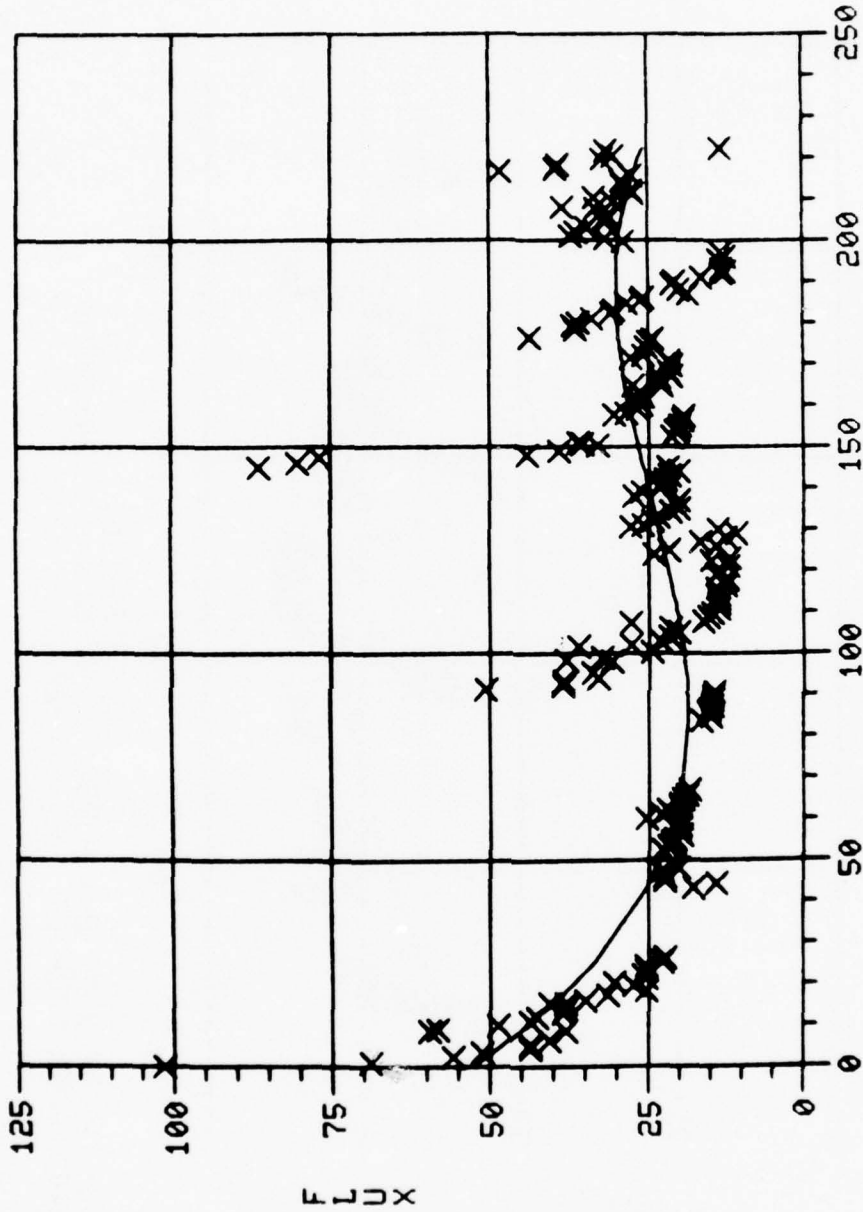

Y = -.201E-04 X ** 3 + .823E-02 X ** 2 + -.955 X ** 1 + 52.8631
 SQ MULT CORR COEF IS .302

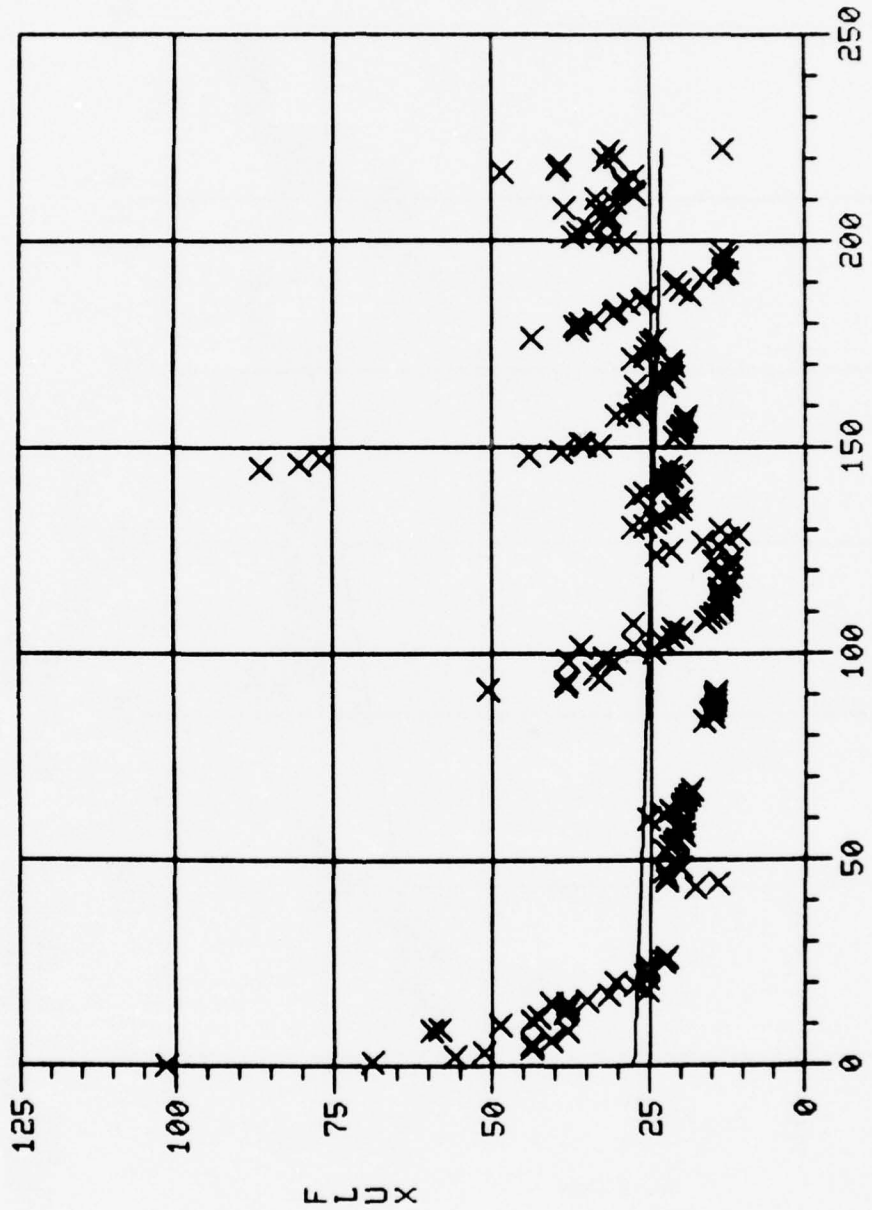

Y = 27.540 EXP(-.001 X)
 SO MULT CORR COEF IS .015

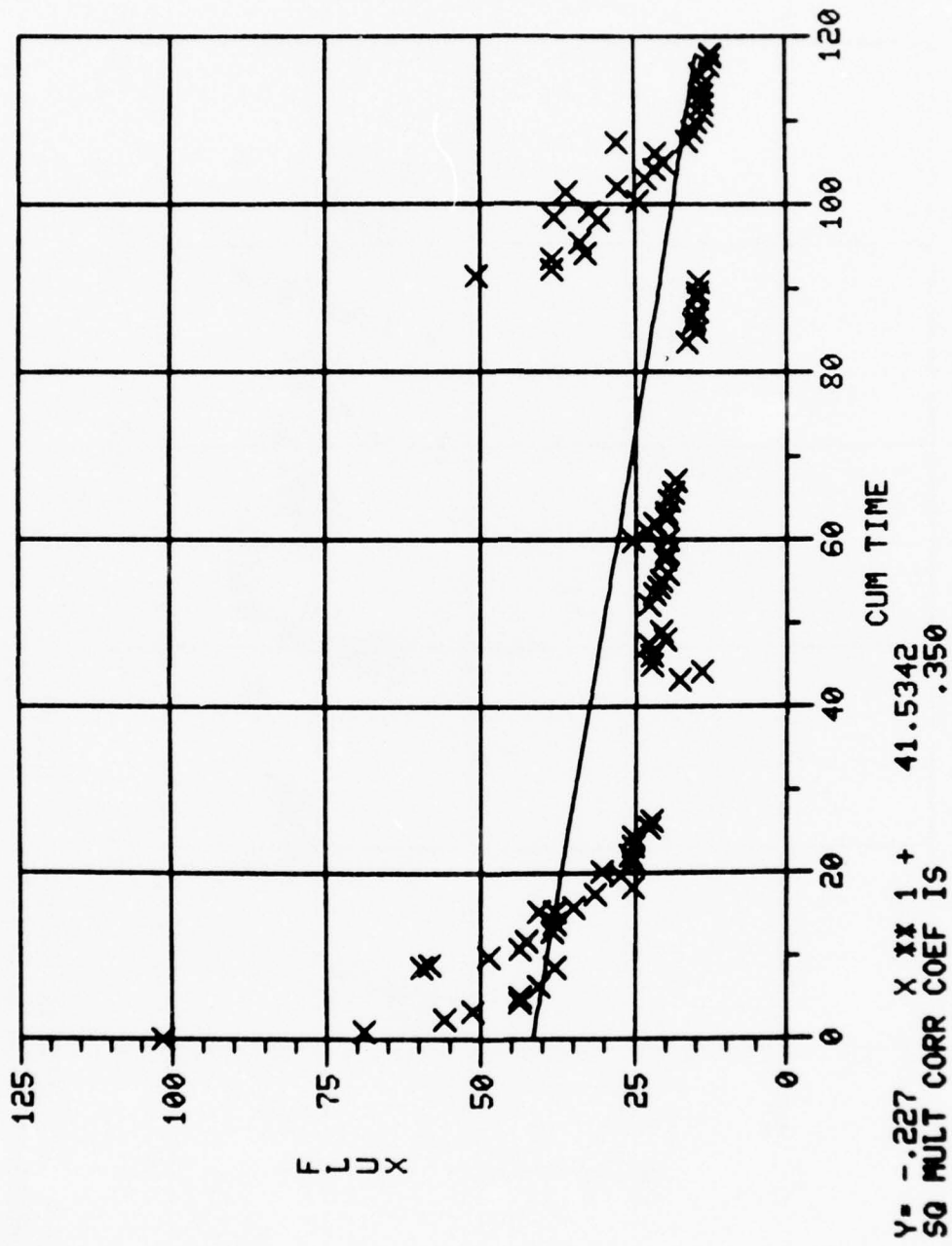

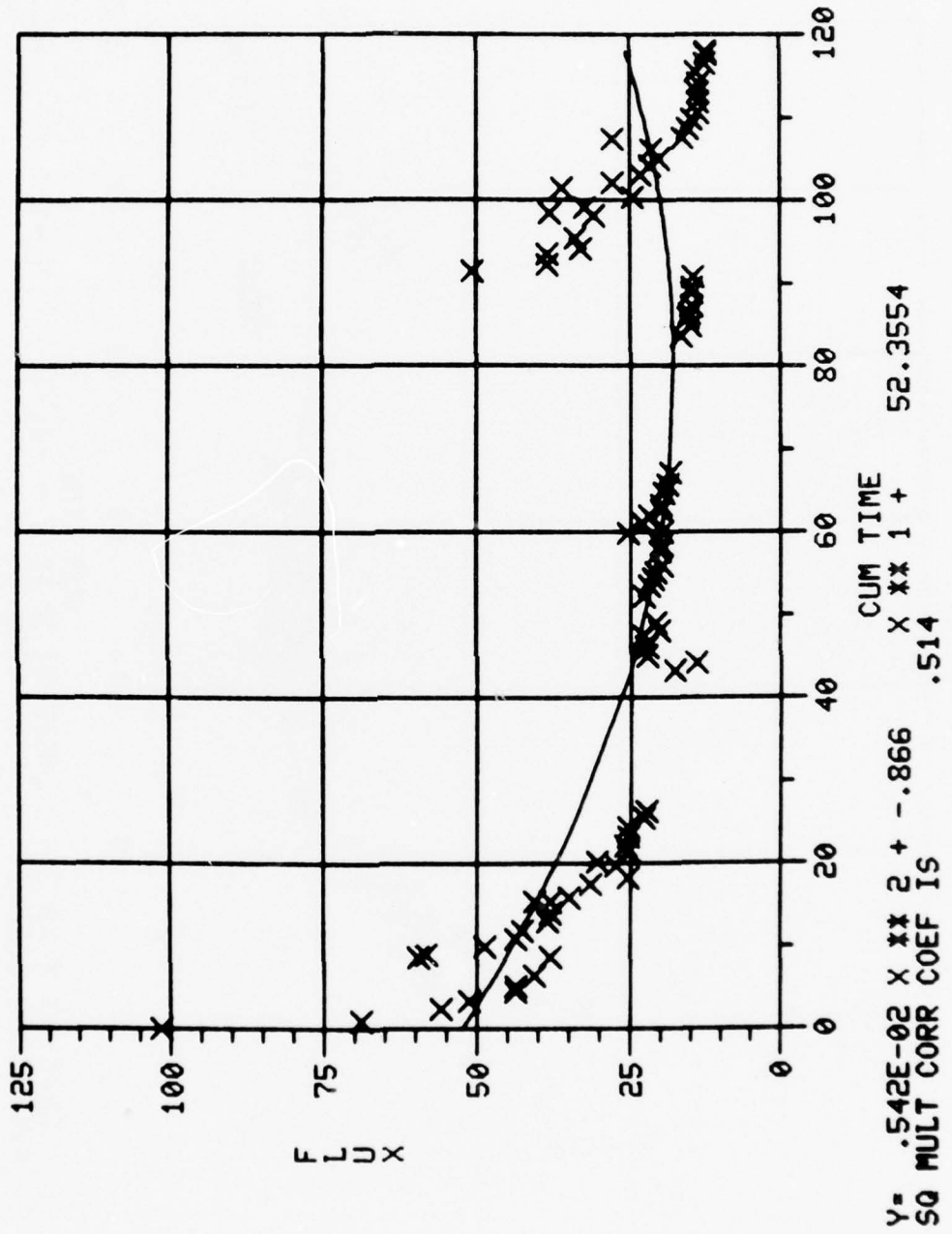

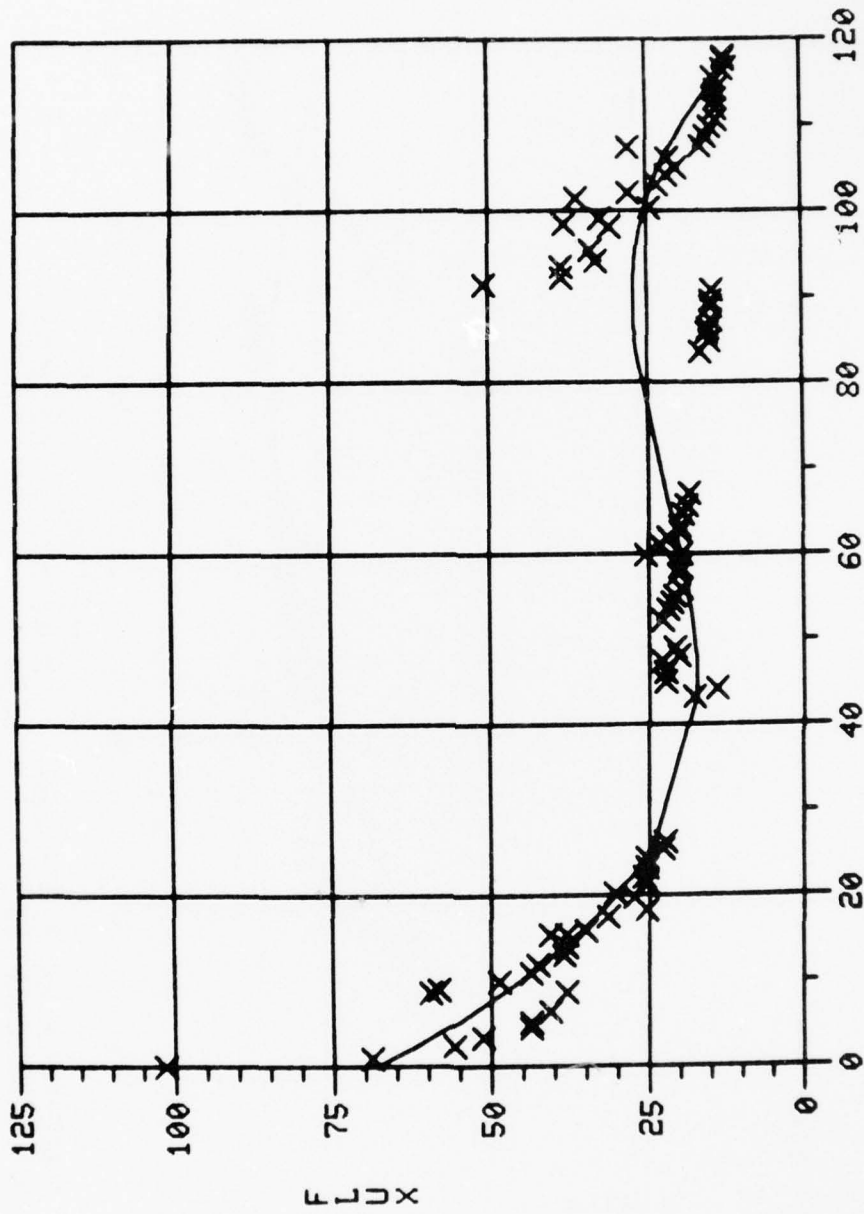

Y = $-.224E-03 X^{**} 3 + .452E-01 X^{**} 2 + -2.71 X^{**} 1 + 68.0482$
 SQ MULT CORR COEF IS .732

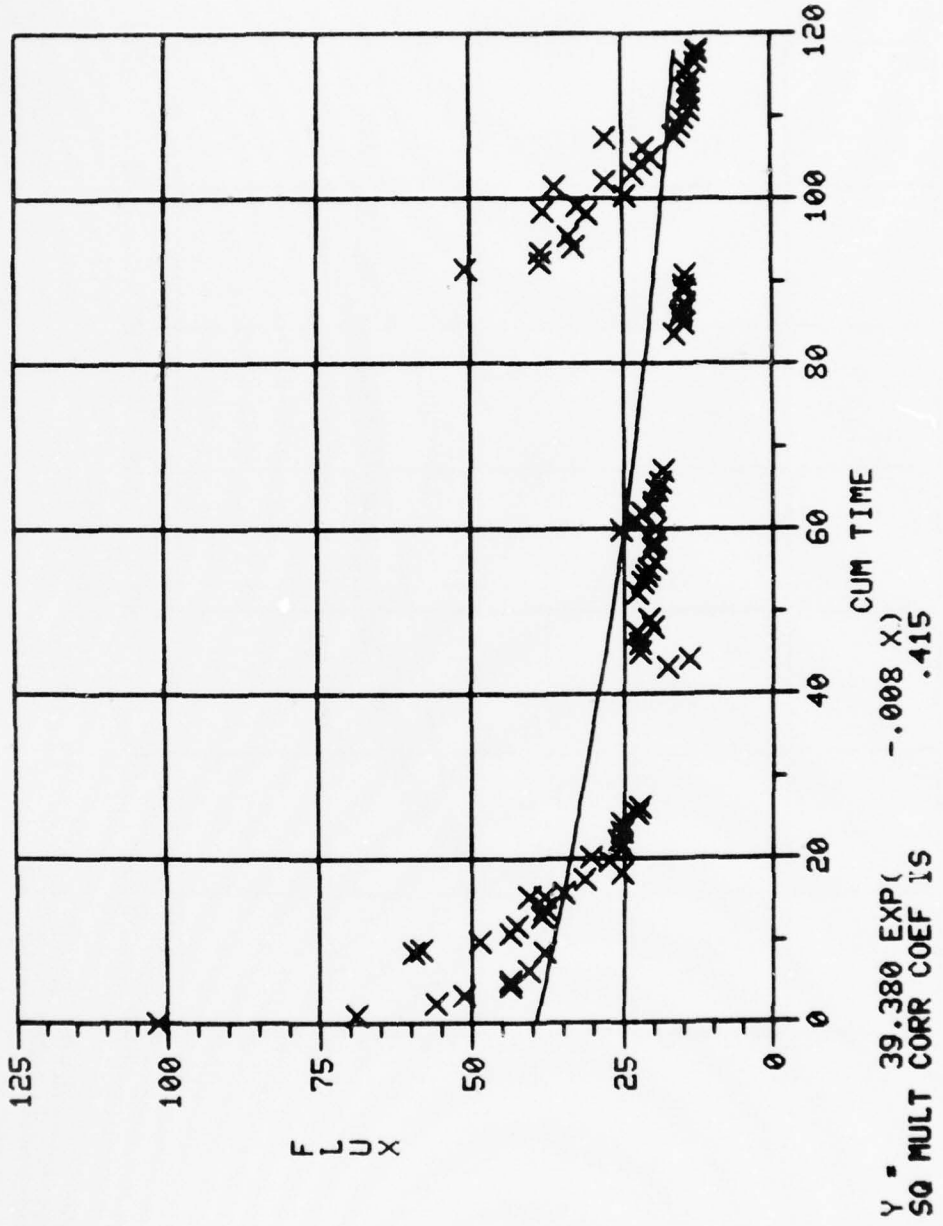

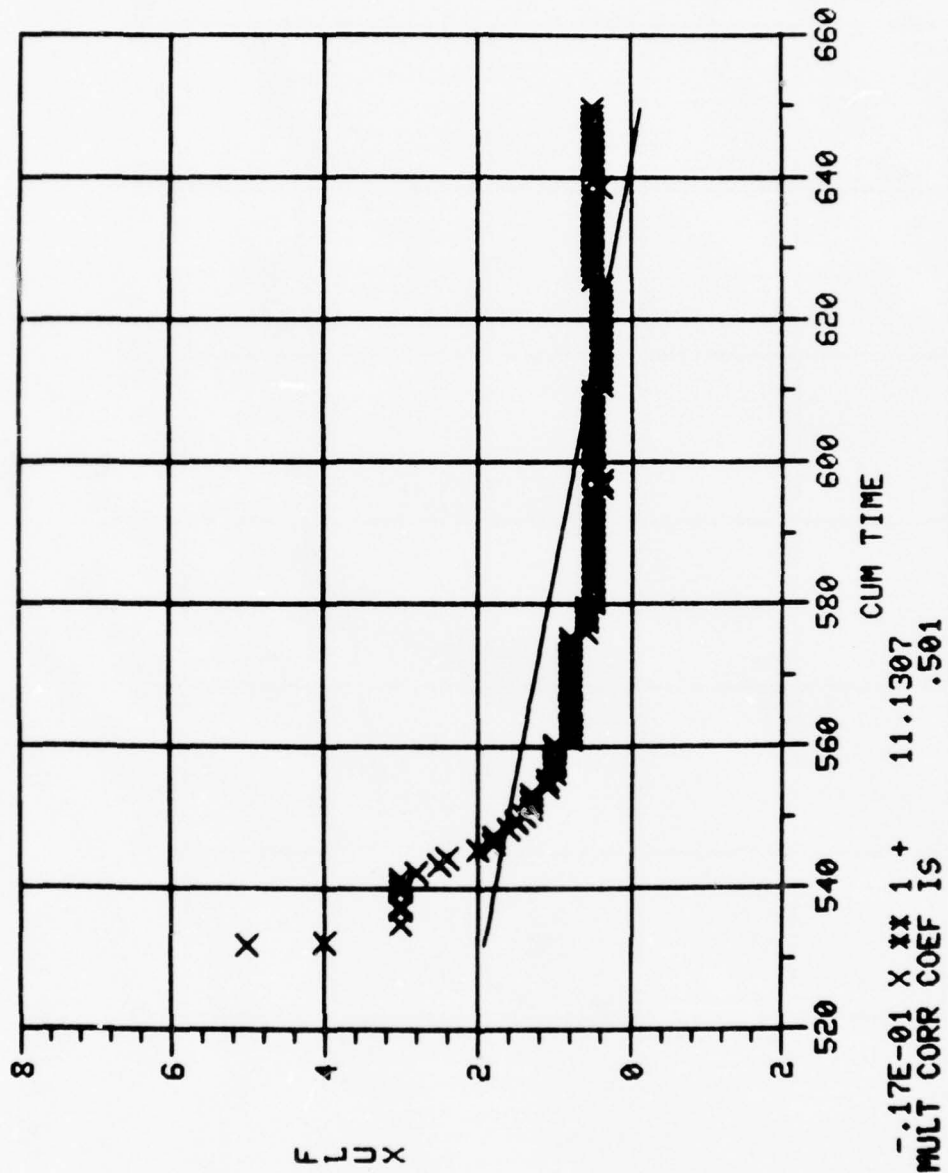

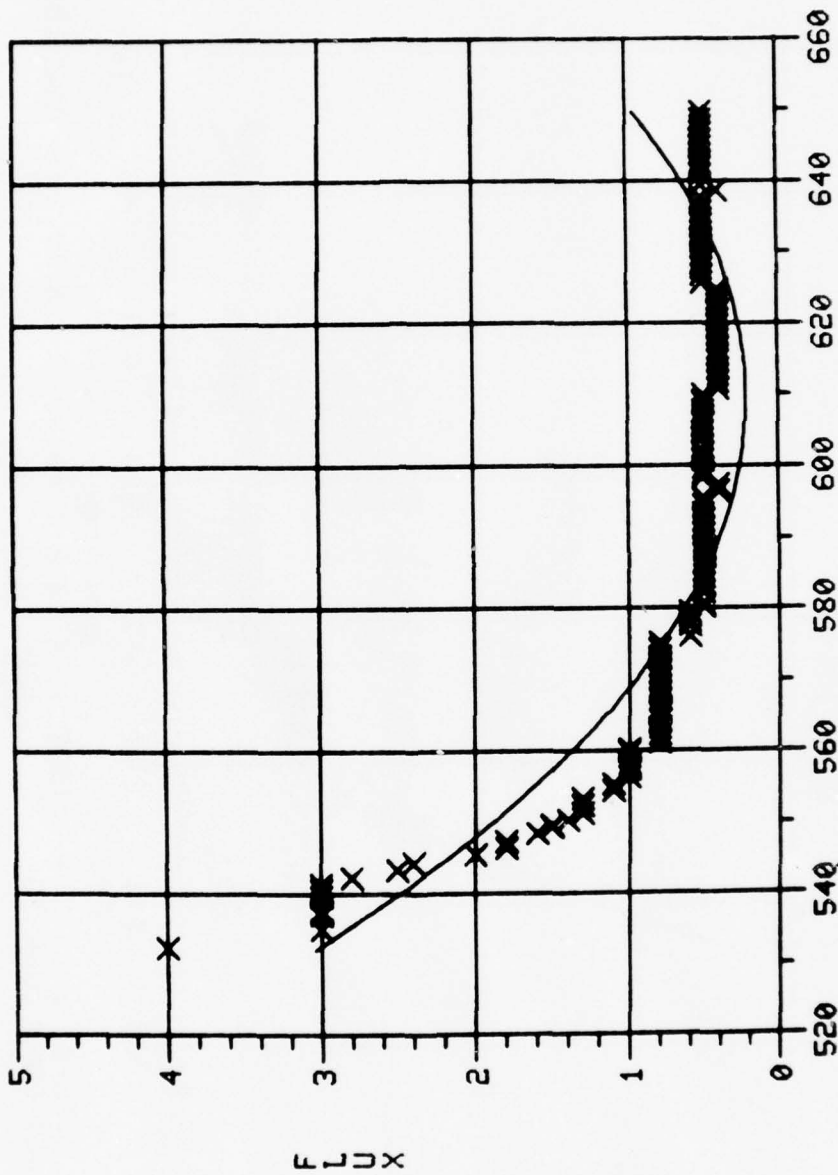

$Y = .467E-03 X^{**2} + -.570 X^{**1} + 173.9042$
 SQ MULT CORR COEF IS .837

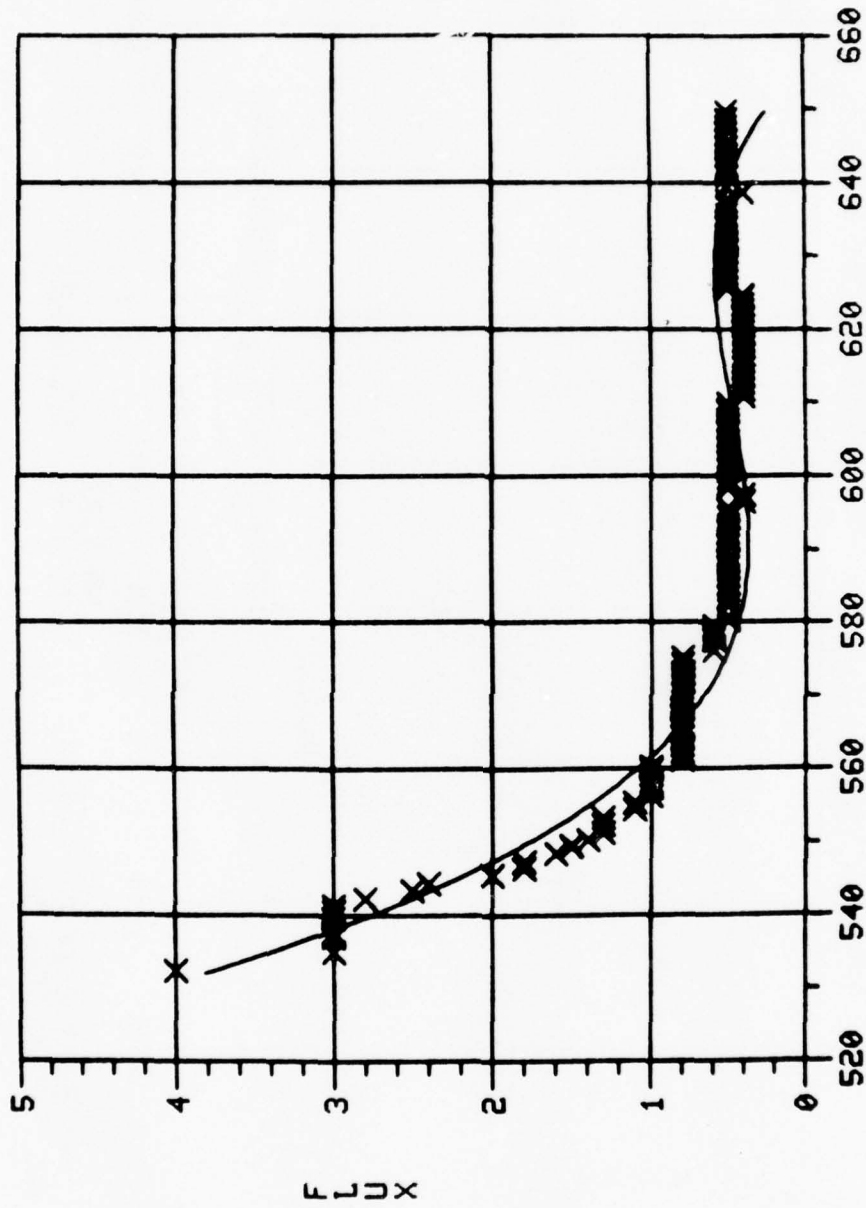

Y= -.870E-05 X ** 3 + .159E-01 X ** 2 + -9.68 X ** 1 + 1962.8320
 SQ MULT CORR COEF IS .944

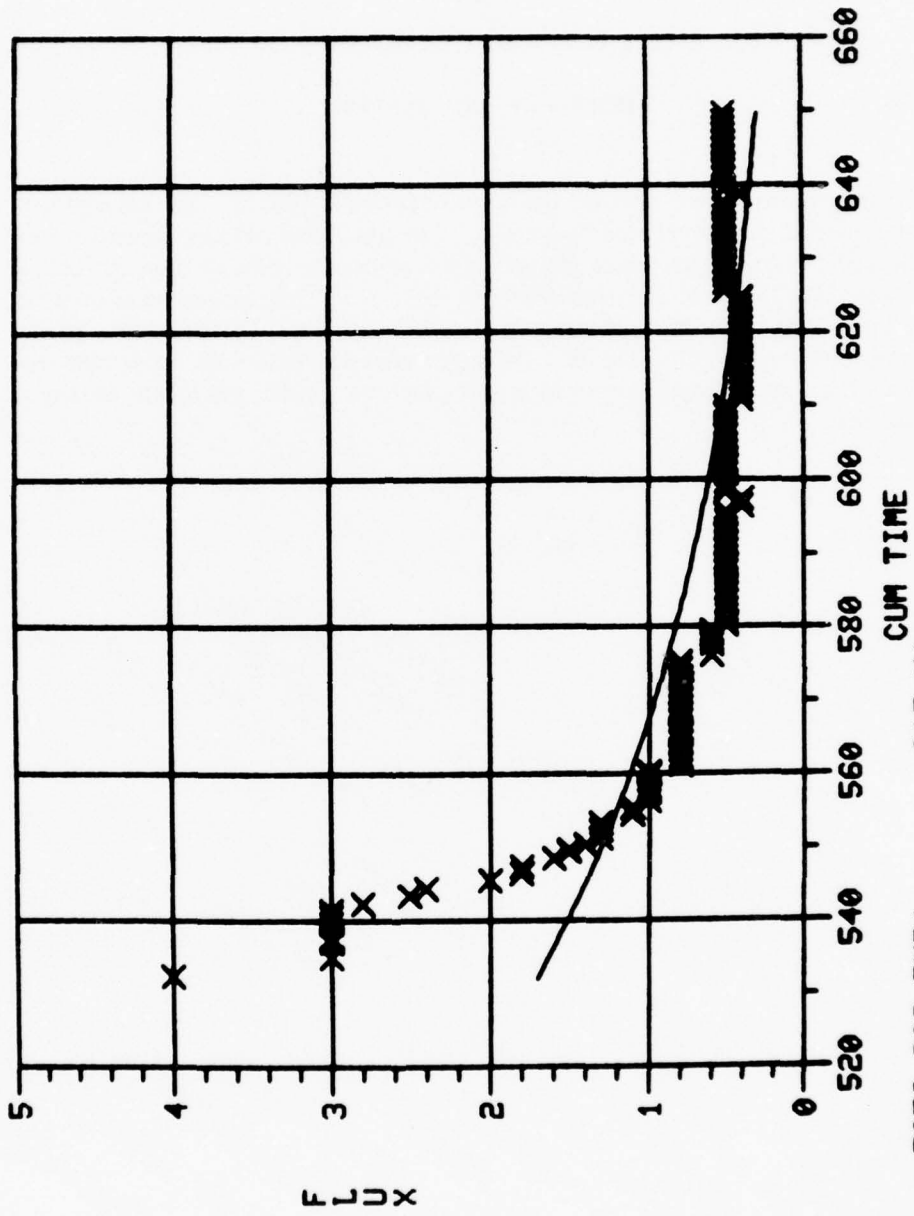

APPENDIX D

CURVE FITS FOR DAILY OPERATION OF THE HOLLOW-FIBER SYSTEM

The graphs in this section represent the segments shown in Table 2. Each segment represents the time period between backflushes. The usual length of time covered is 5 to 8 hours. However, in some cases, the system was allowed to continue running through the night. The length of these runs could be from 24 to 32 hours depending on what time the following day the system was backflushed. A total of 26 segments or graphs is considered for each fit. The first 26 graphs represent first-order fits for the segments. These are followed in turn by second-order, third-order, and finally, the exponential fits.

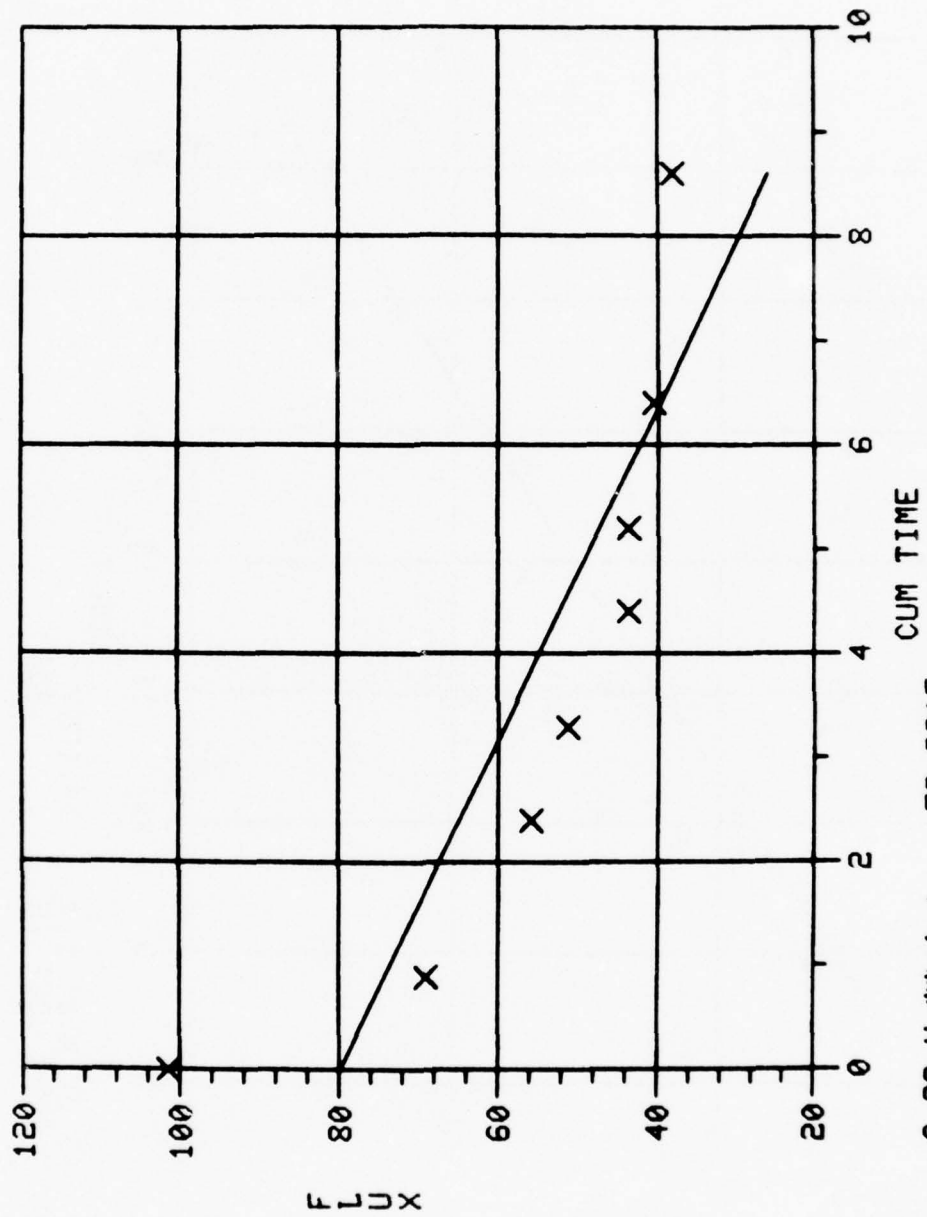

Y = -6.28 X + 100.00
 SQ MULT CORR COEF IS 79.8915 .720

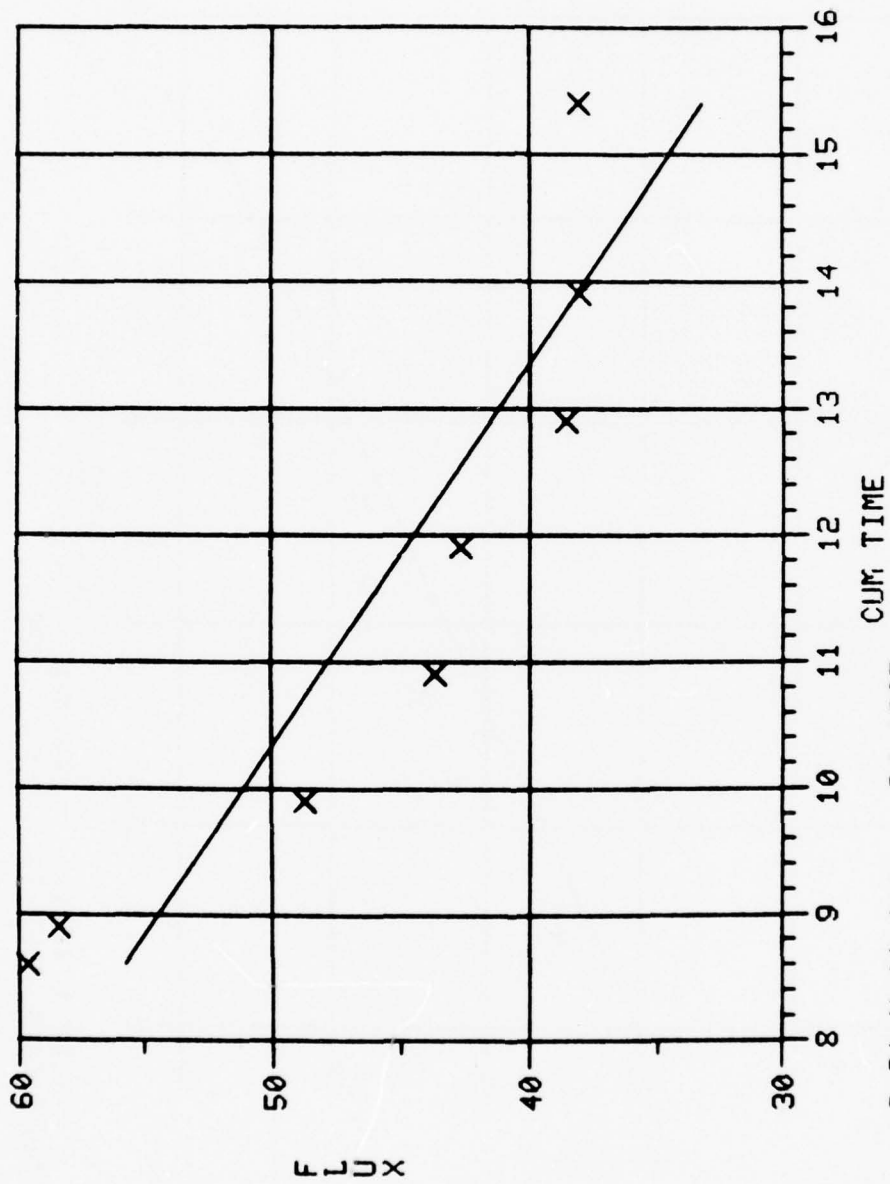

Y = -3.31 X + 84.1897
 SQ MULT CORR COEF IS .830

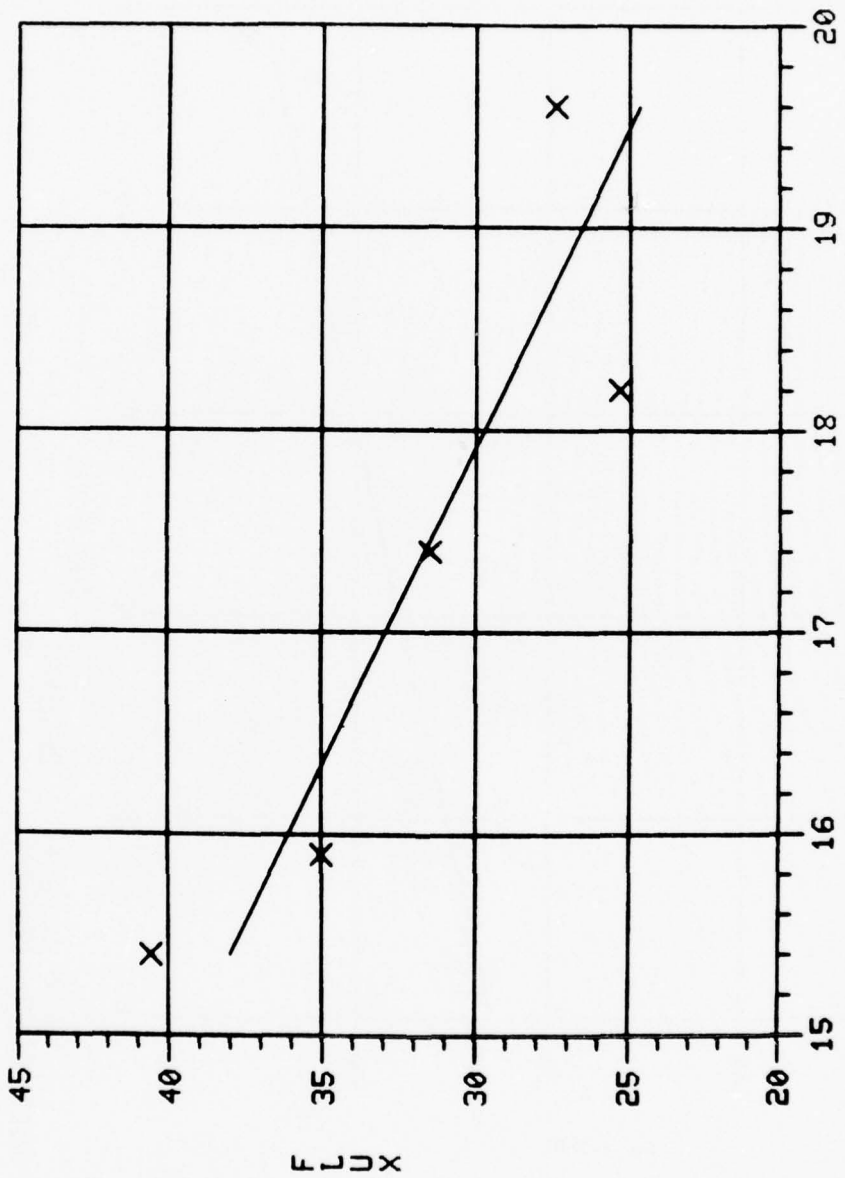

Y = -3.18 X ** 1 + 86.9290
 SO MULT CORR COEF IS .796

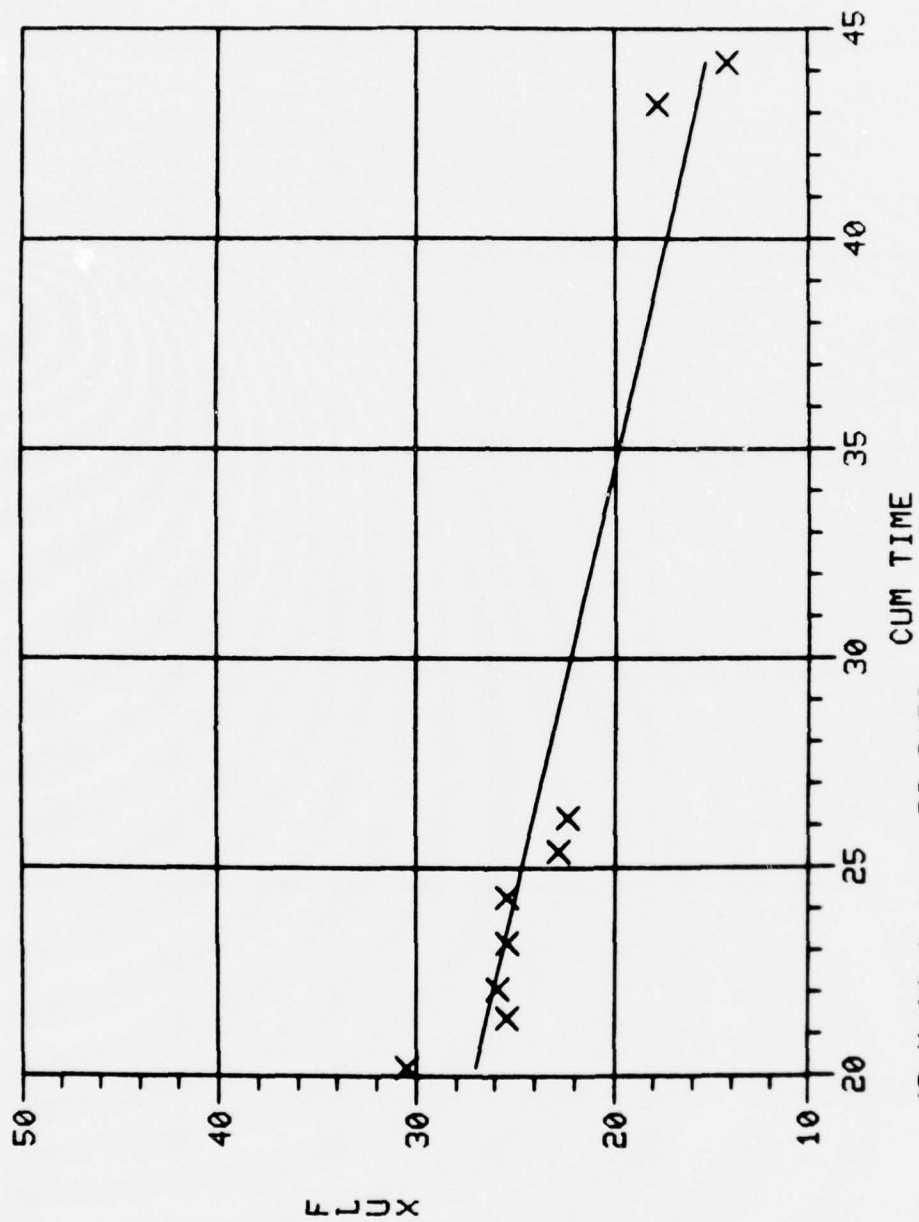

Y = -.49 X + 36.8153
 SQ MULT CORR COEF IS .870

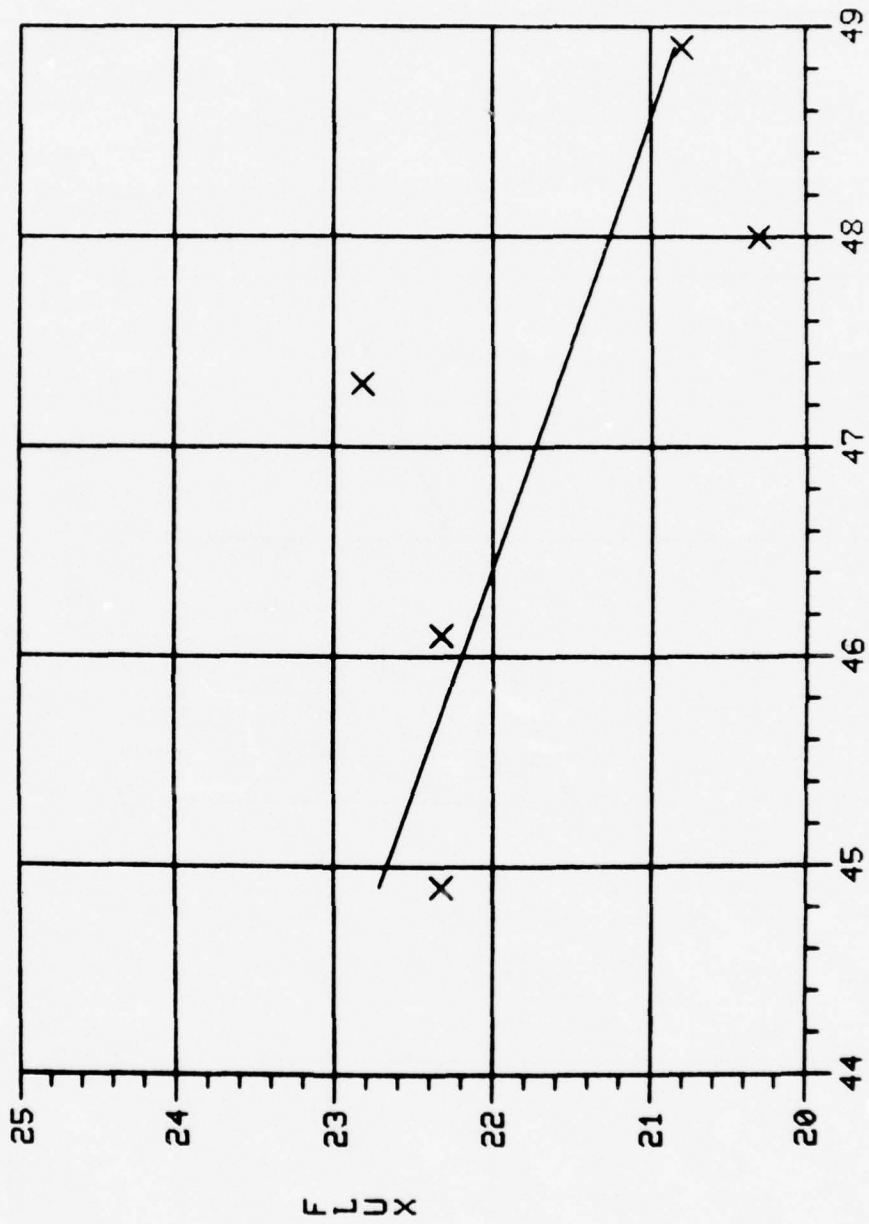

CUM TIME

Y = -.47 X ** 1 + 43.7153
 SQ MULT CORR COEF IS .453

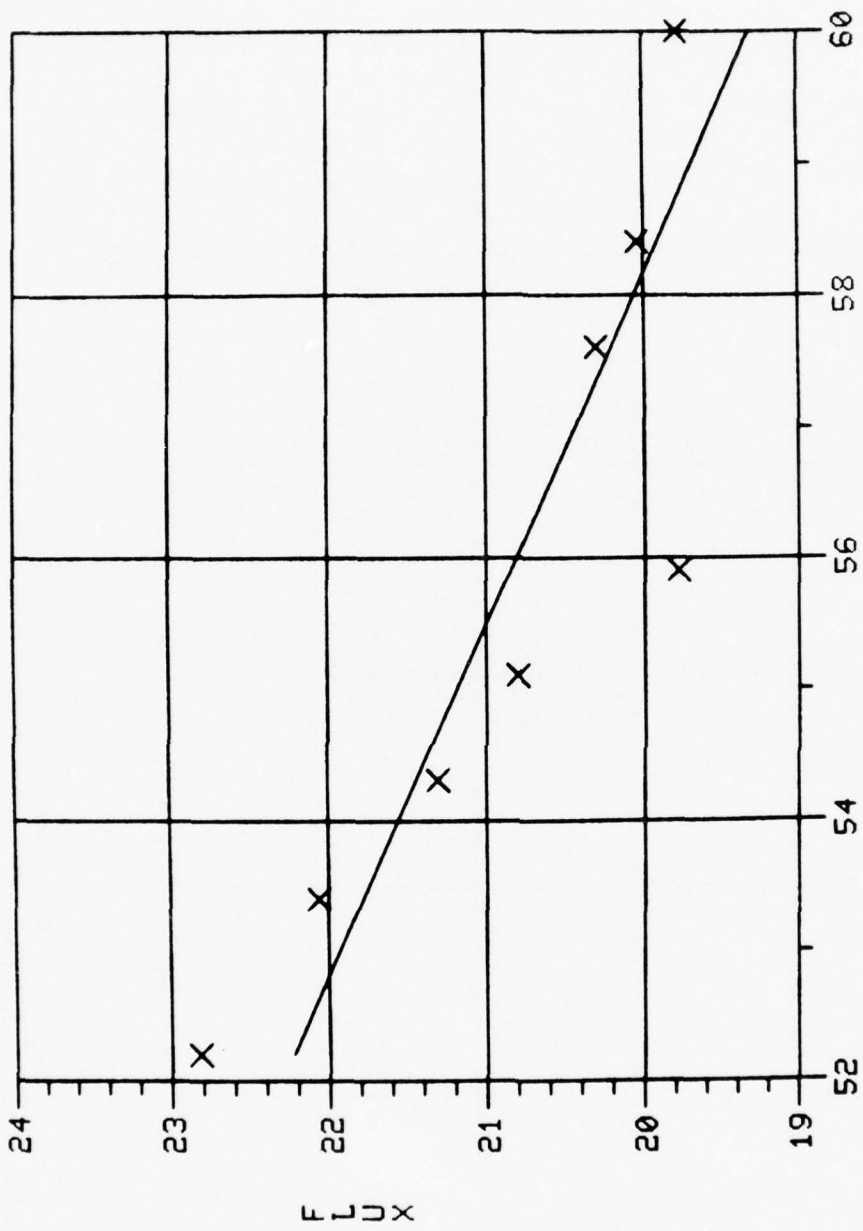

Y = -.37 X + 41.7327
 SQ MULT CORR COEF IS .779

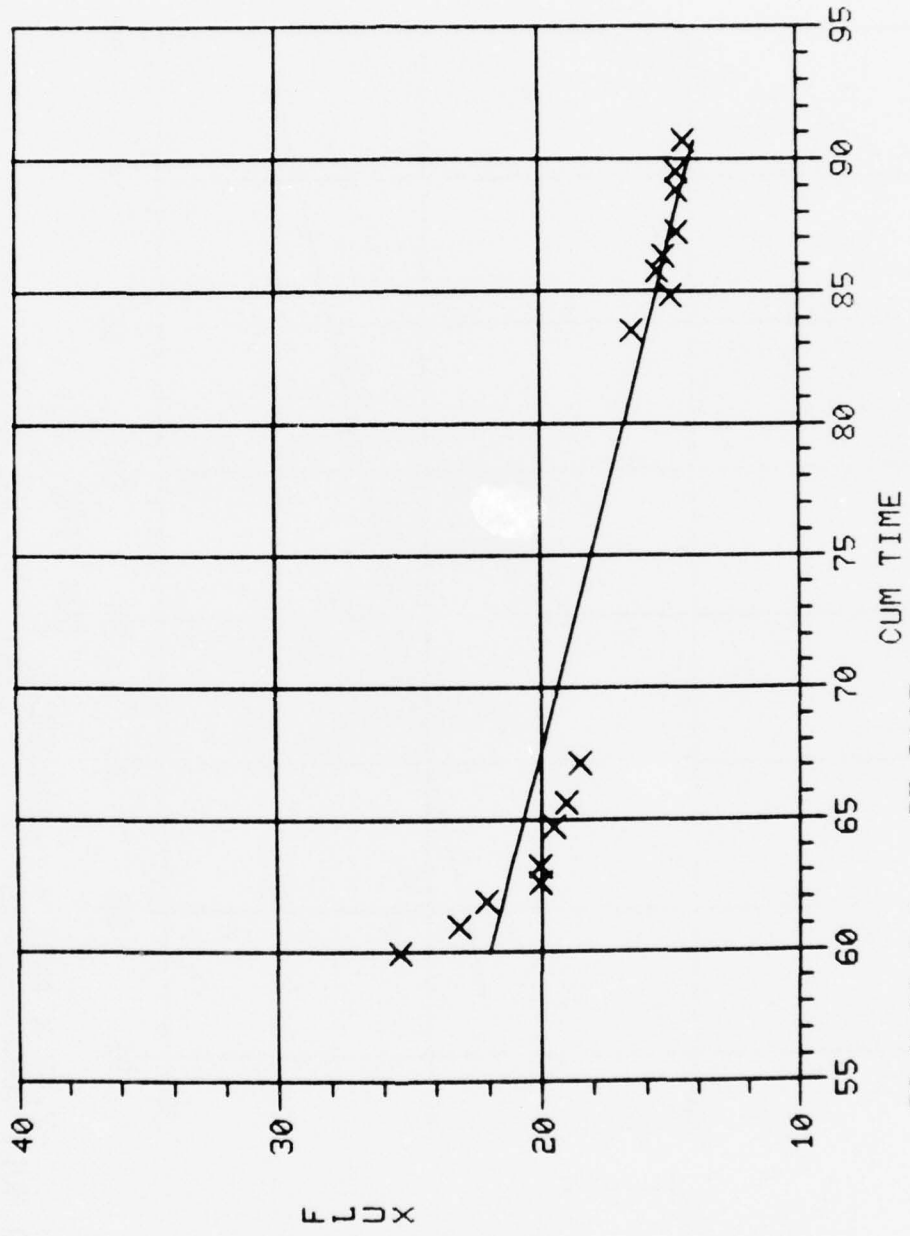

Y = -.26 X + 37.3115
 SQ MULT CORR COEF IS .867

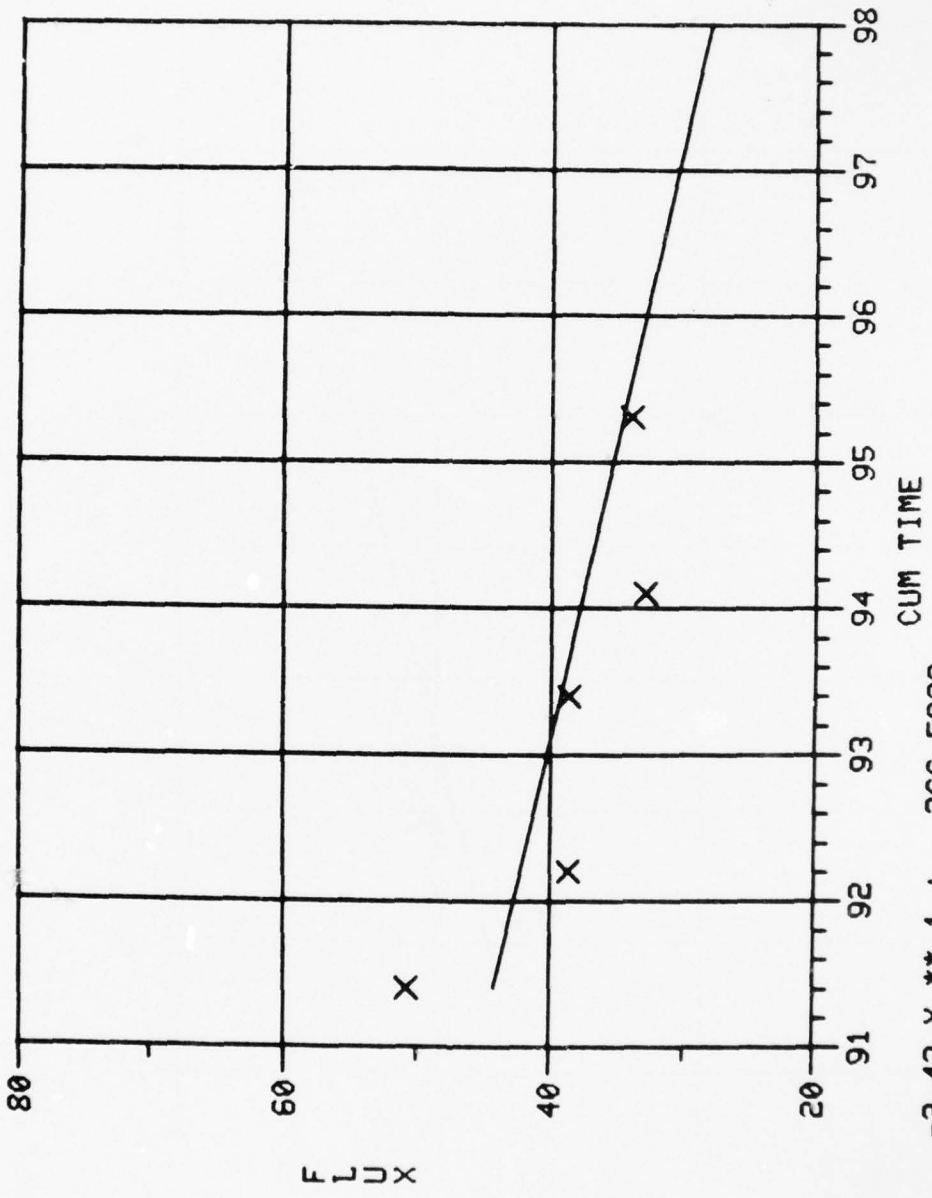

$$Y = -2.43 X + 266.5823$$
 SQ MULT CORR COEF IS .657

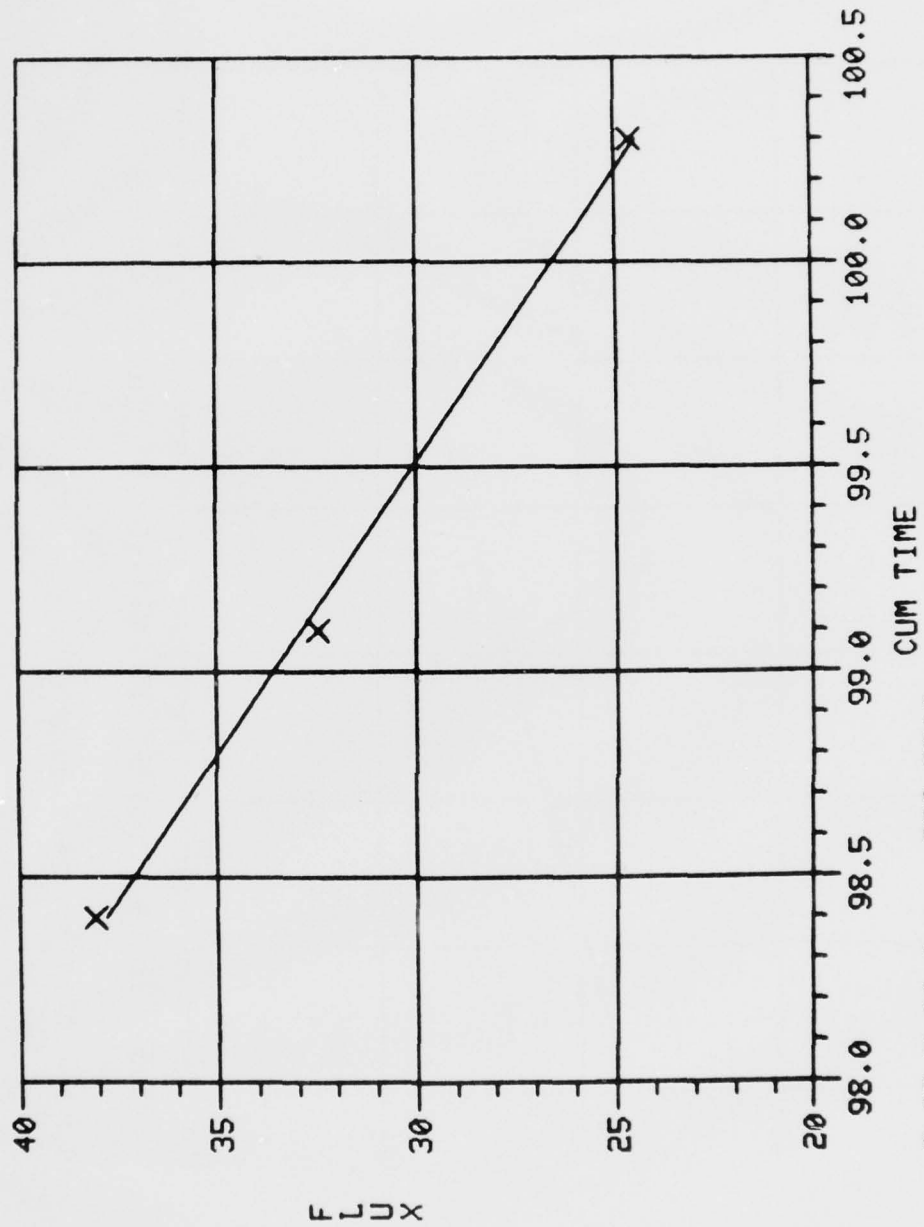

Y= -7.02 X ** 1 + 728.2510
 SQ MULT CORR COEF IS .997

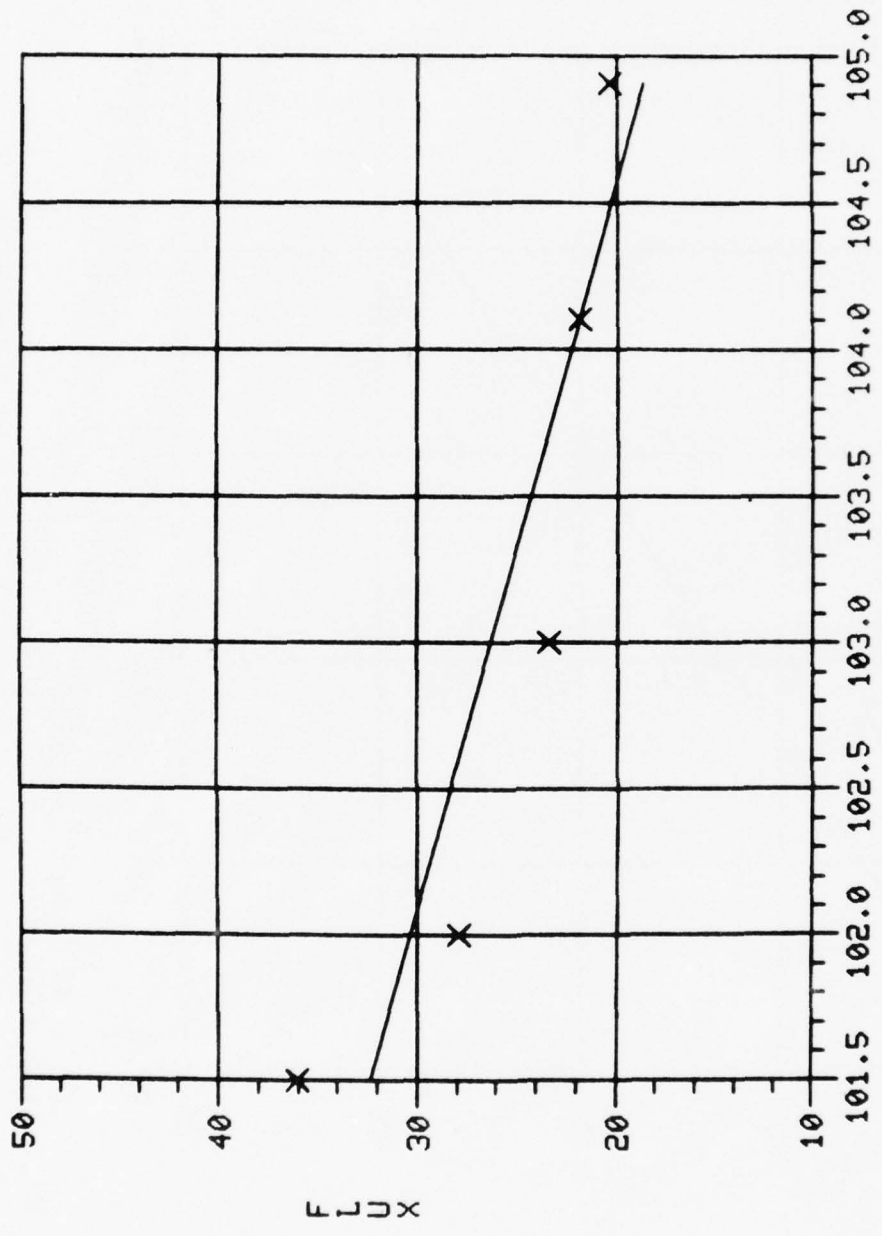

$$Y = -4.03 X + 441.0528$$
 SQ MULT CORR COEF IS .808

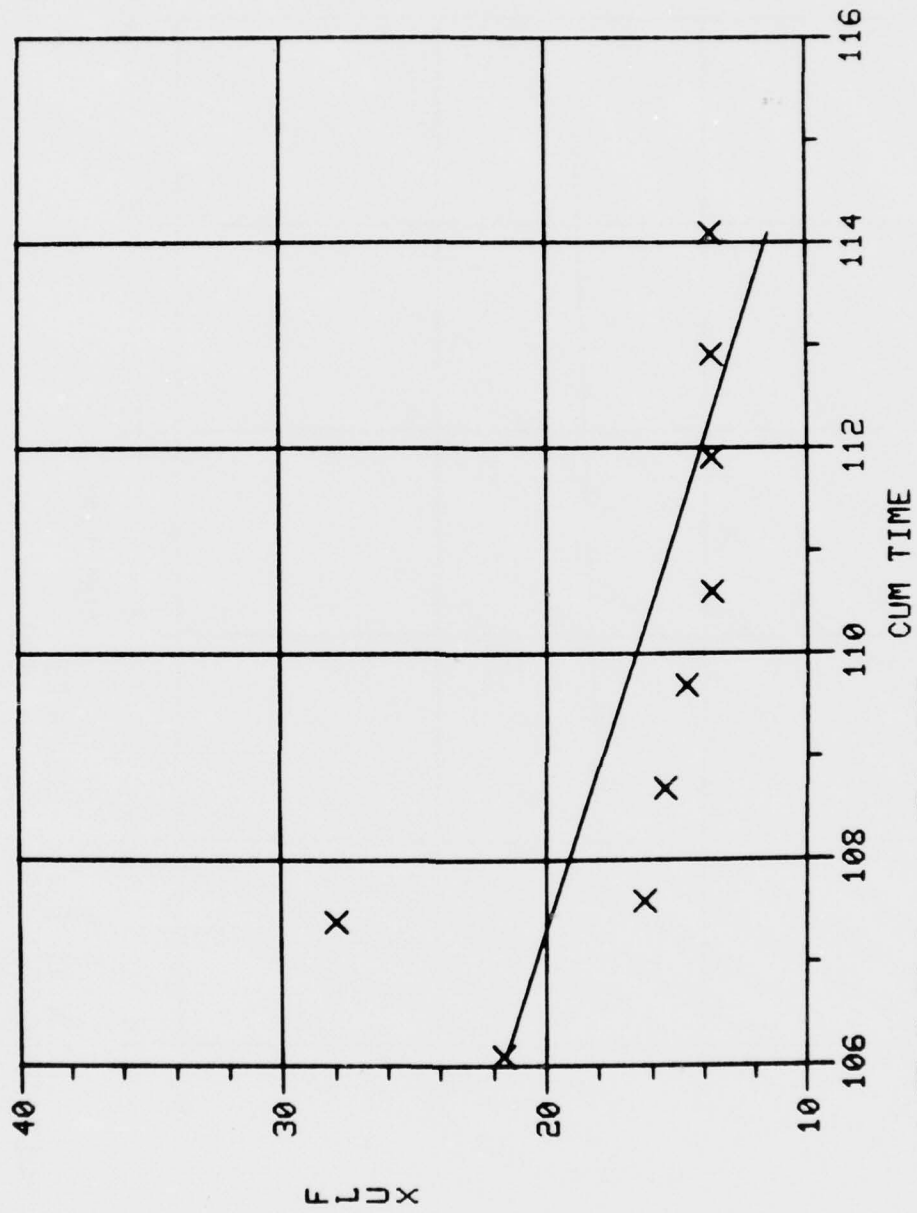

Y = -1.25 X + 154.1233
 SQ MULT CORR COEF IS .480

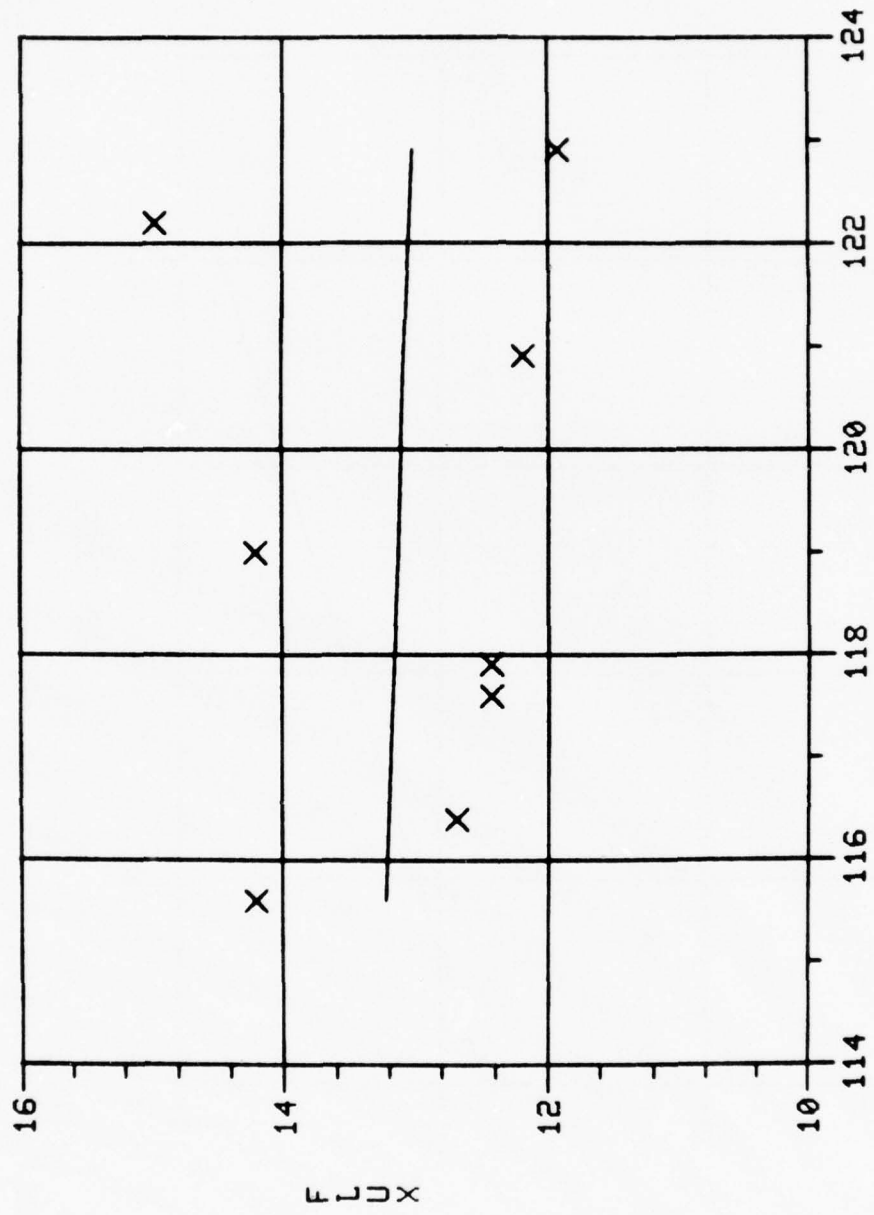

Y = -.03 X XX 1 + 16.3213
 SQ MULT CORR COEF IS .004

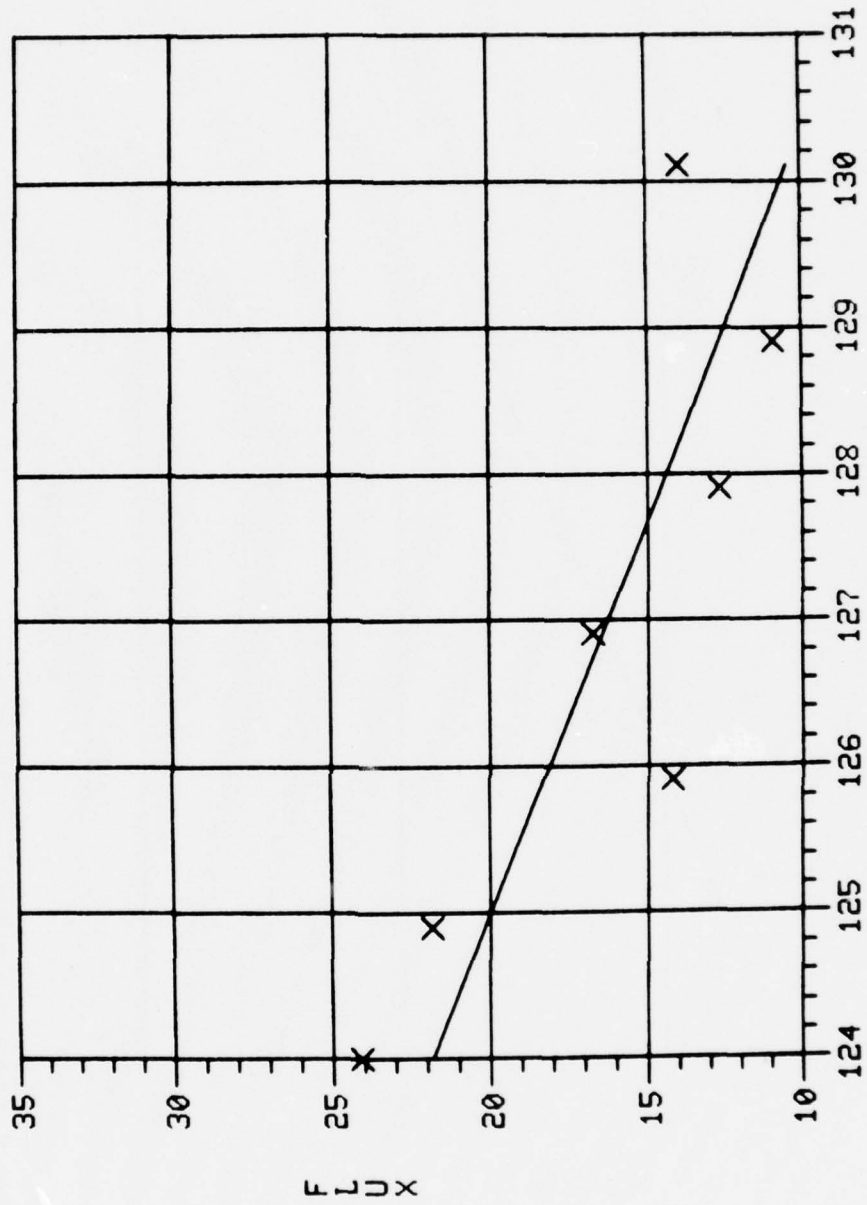

CUM TIME

Y = -1.87 X + 253.3443
 SQ MULT CORR COEF IS .697

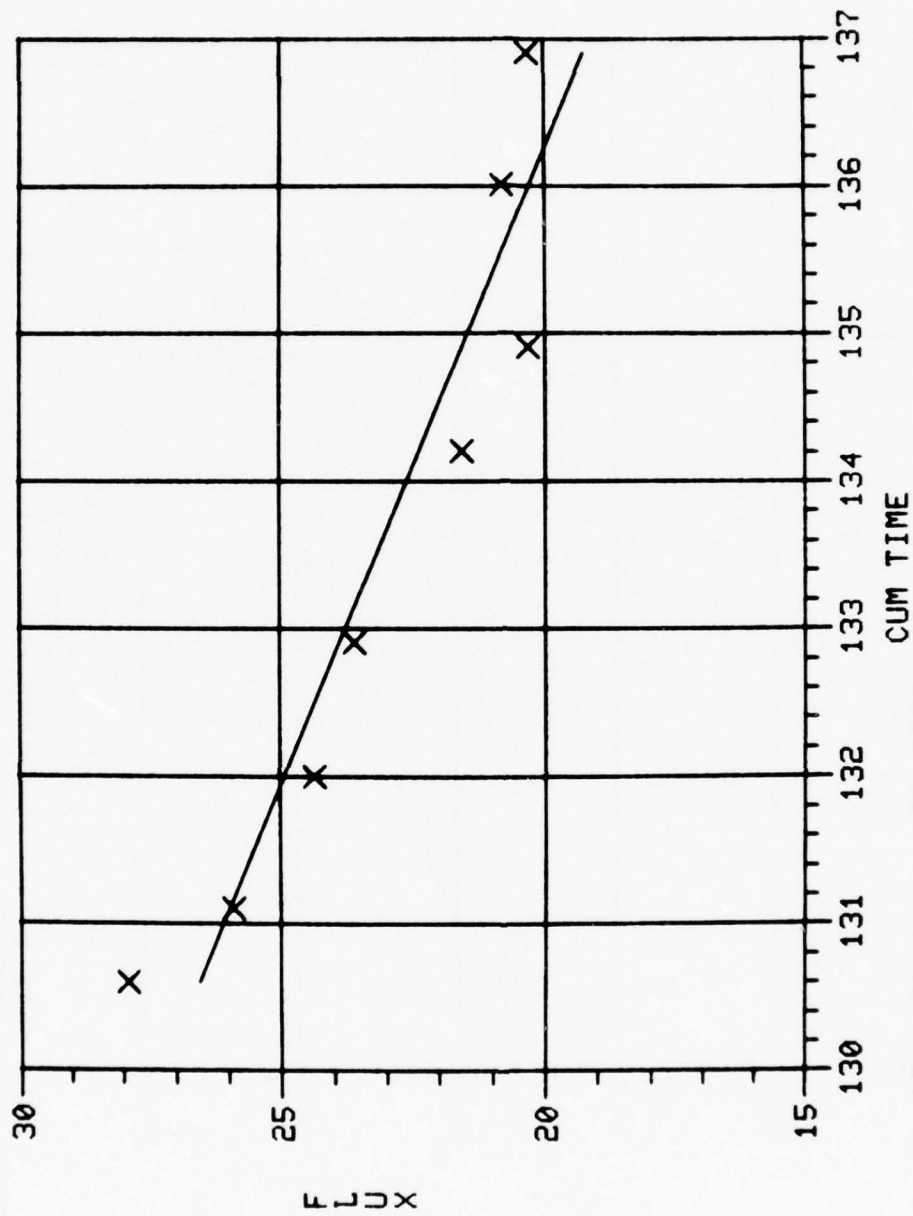

$$Y = -1.16 X + 178.3303$$
 SO MULT CORR COEF IS .894

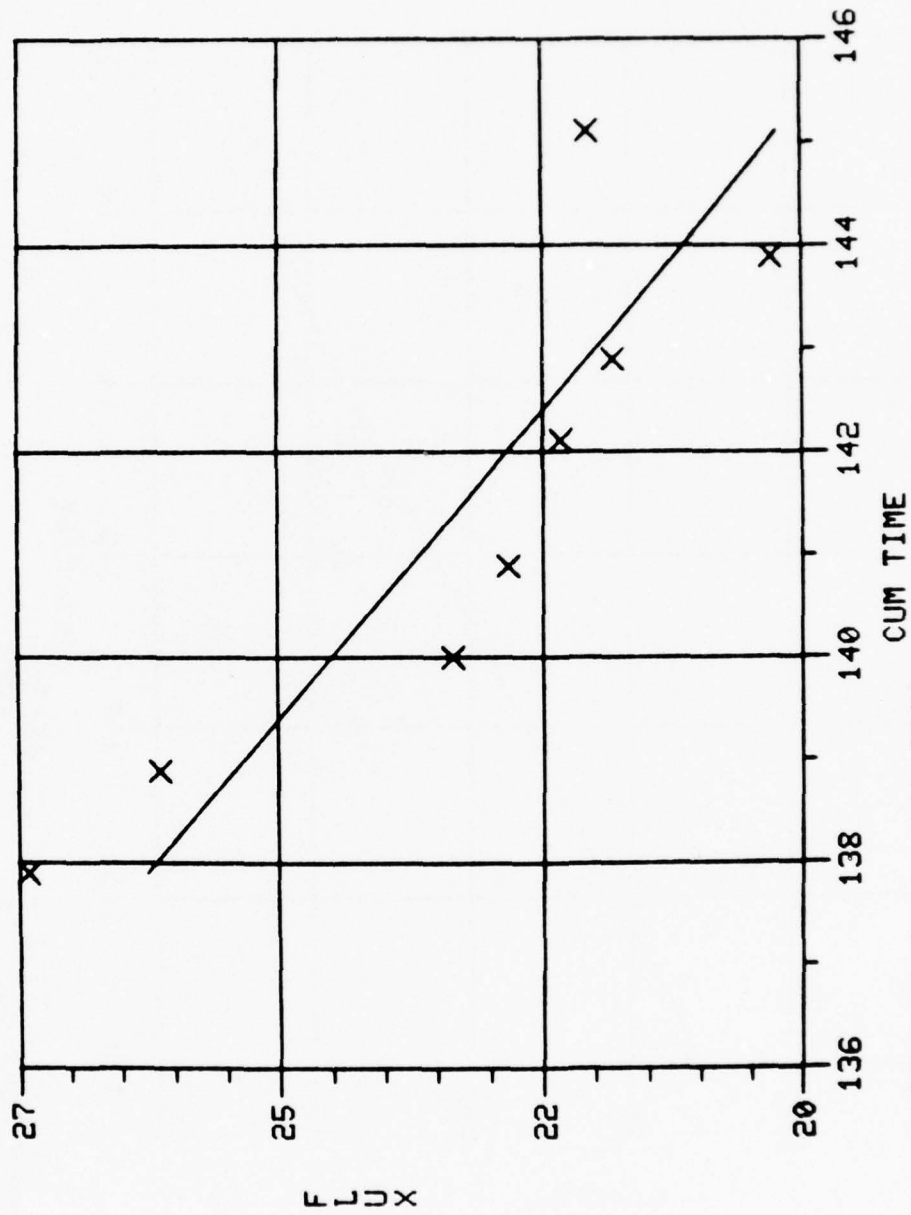

Y = -.83 X + 141.3666
 SQ MULT CORR COEF IS .781

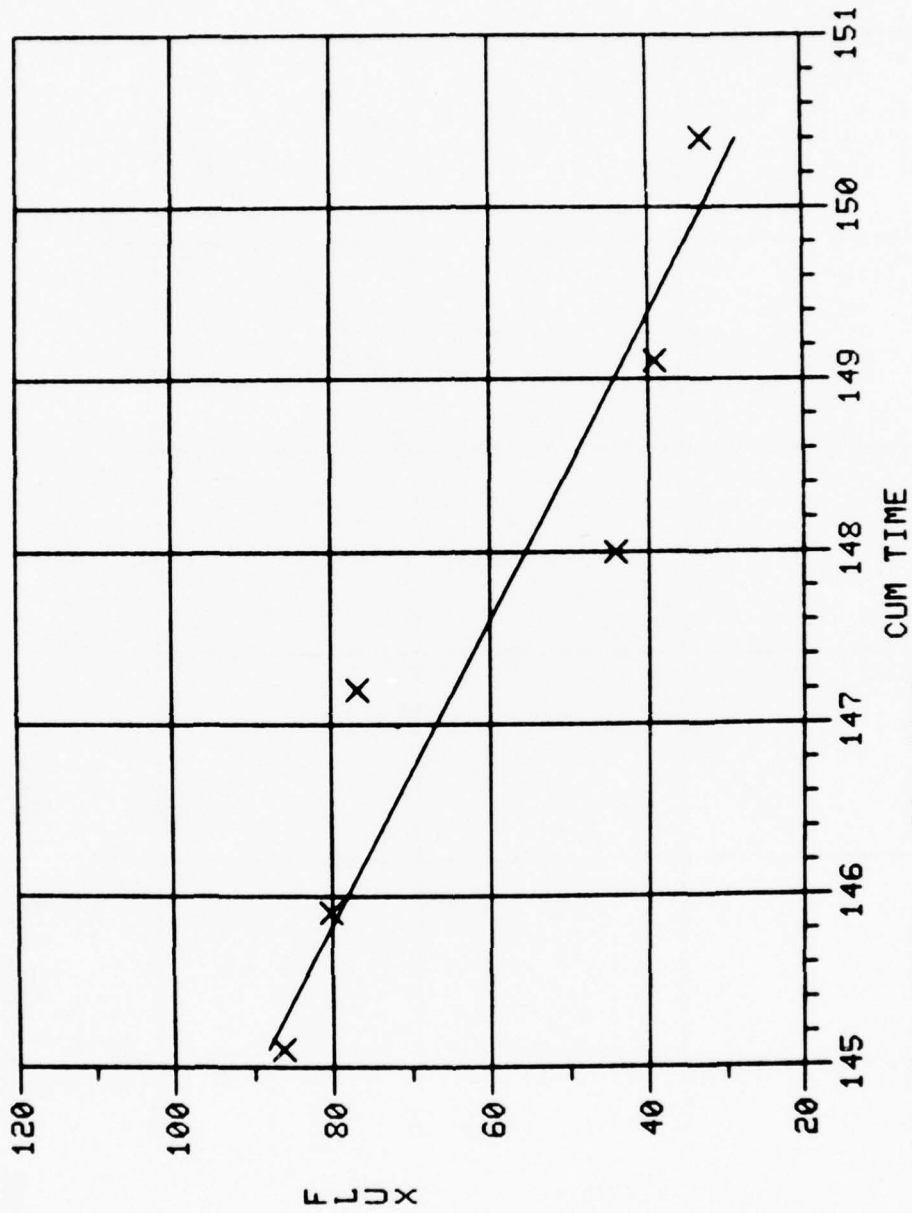

Y = -11.25 X + 1720.6617
 SQ MULT CORR COEF IS .885

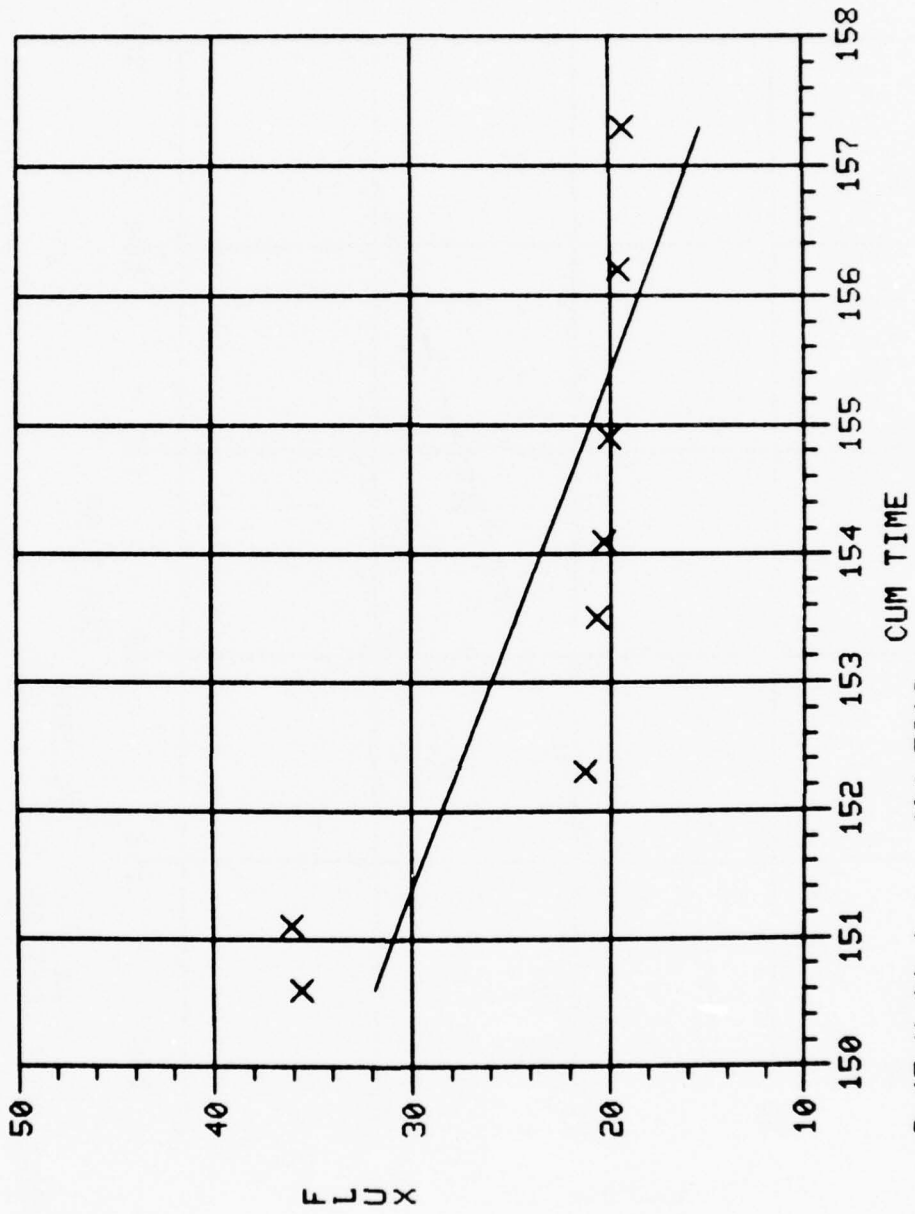

Y = -2.47 X + 404.5616
 SQ MULT CORR COEF IS .654

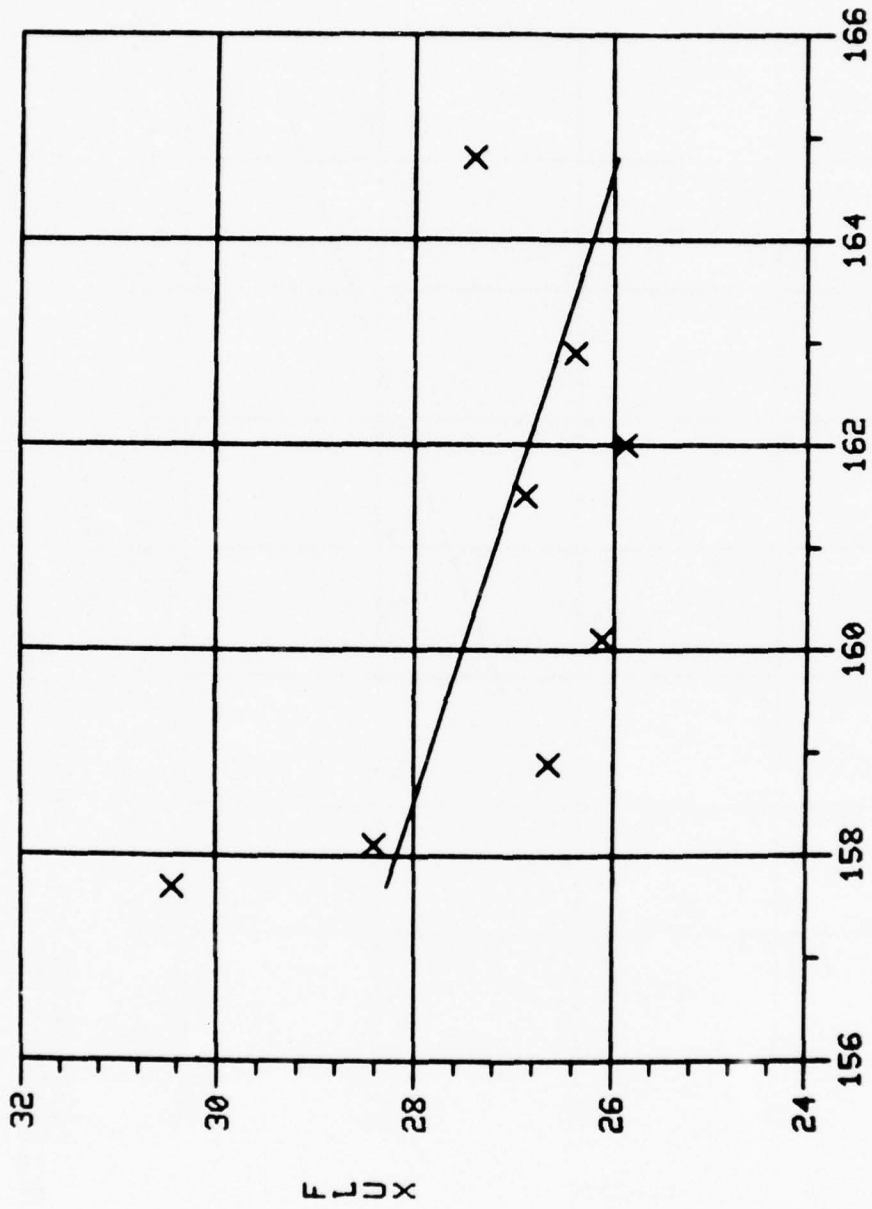

$$Y = -.33 X + 79.8378$$
 SQ MULT CORR COEF IS .291

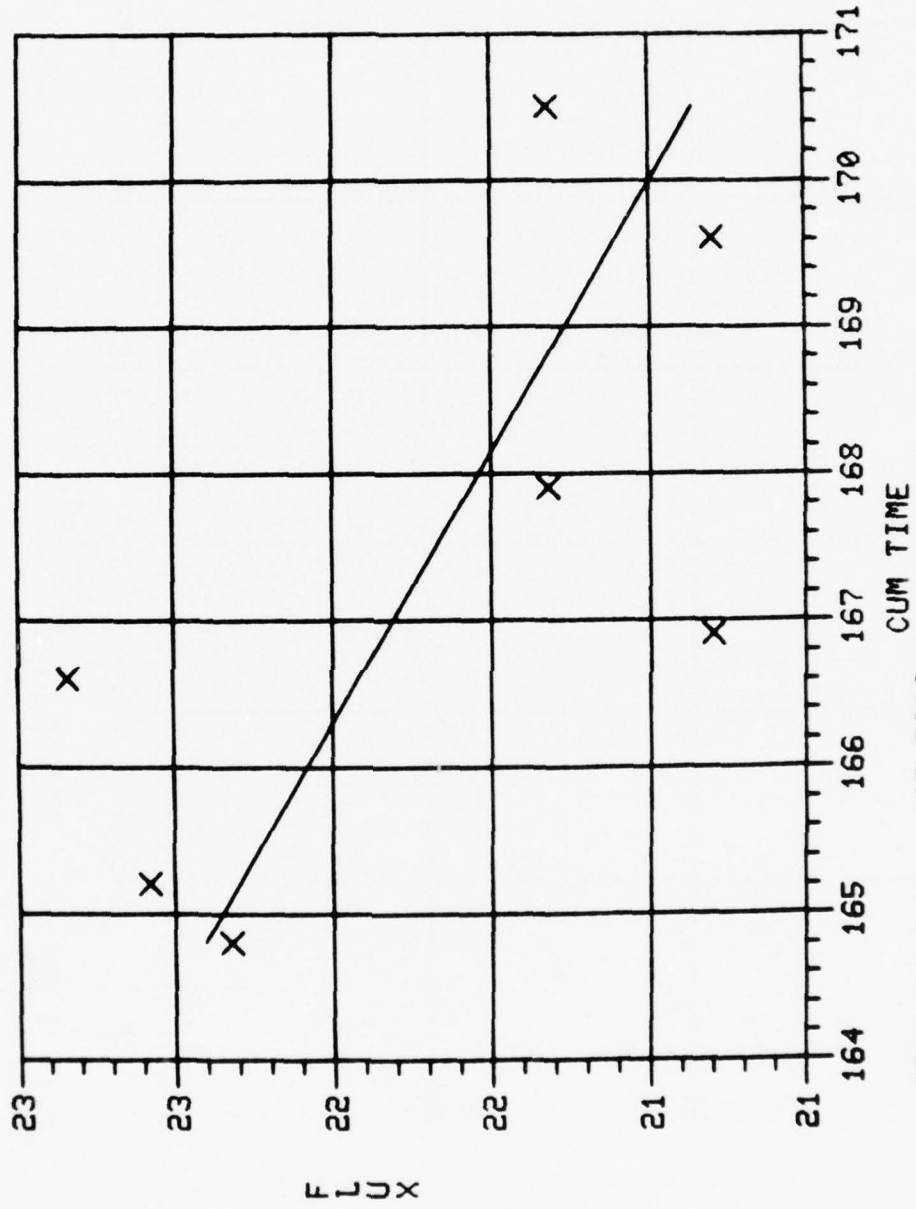

Y = -.27 X + 67.5010
 SQ MULT CORR COEF IS .456

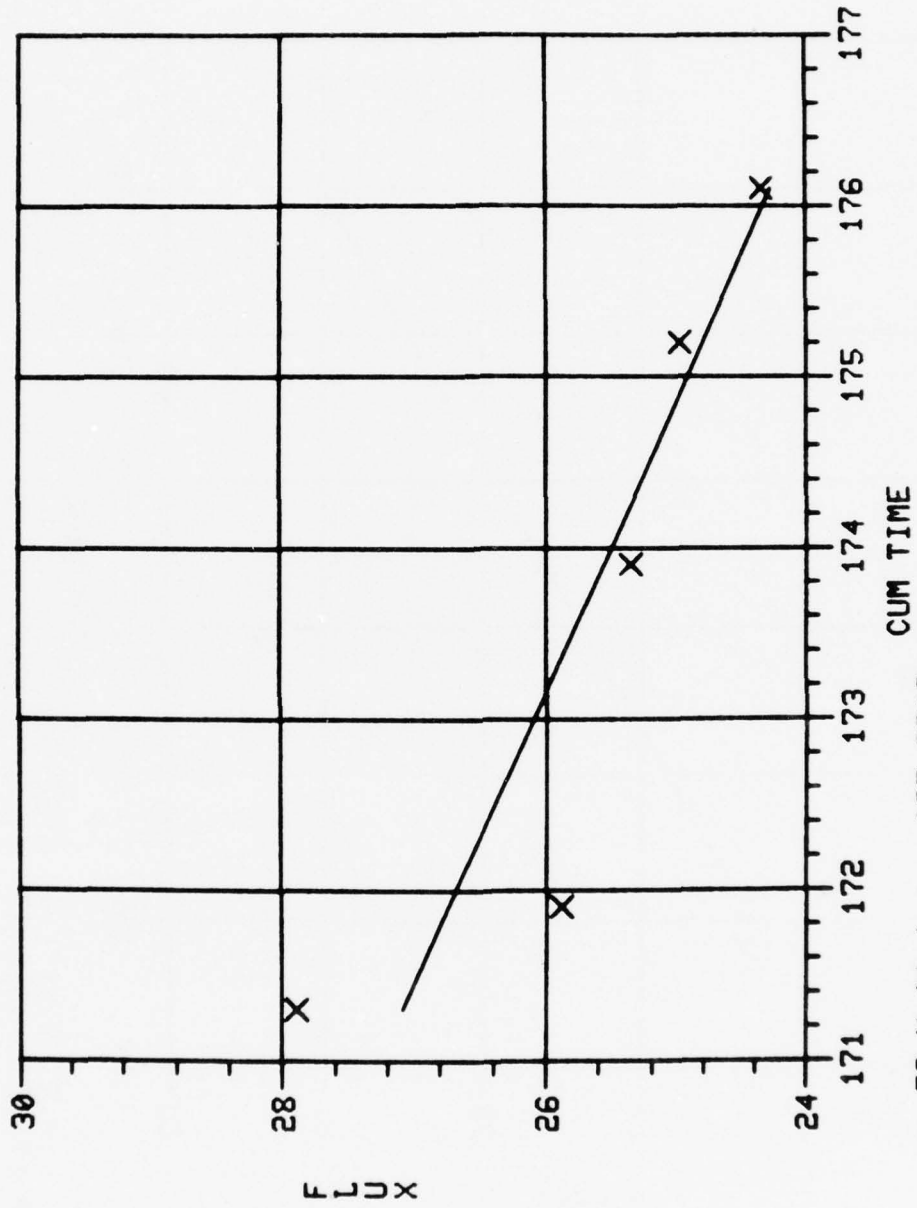

Y = -.58 X + 127.2513
 SQ MULT CORR COEF IS .802

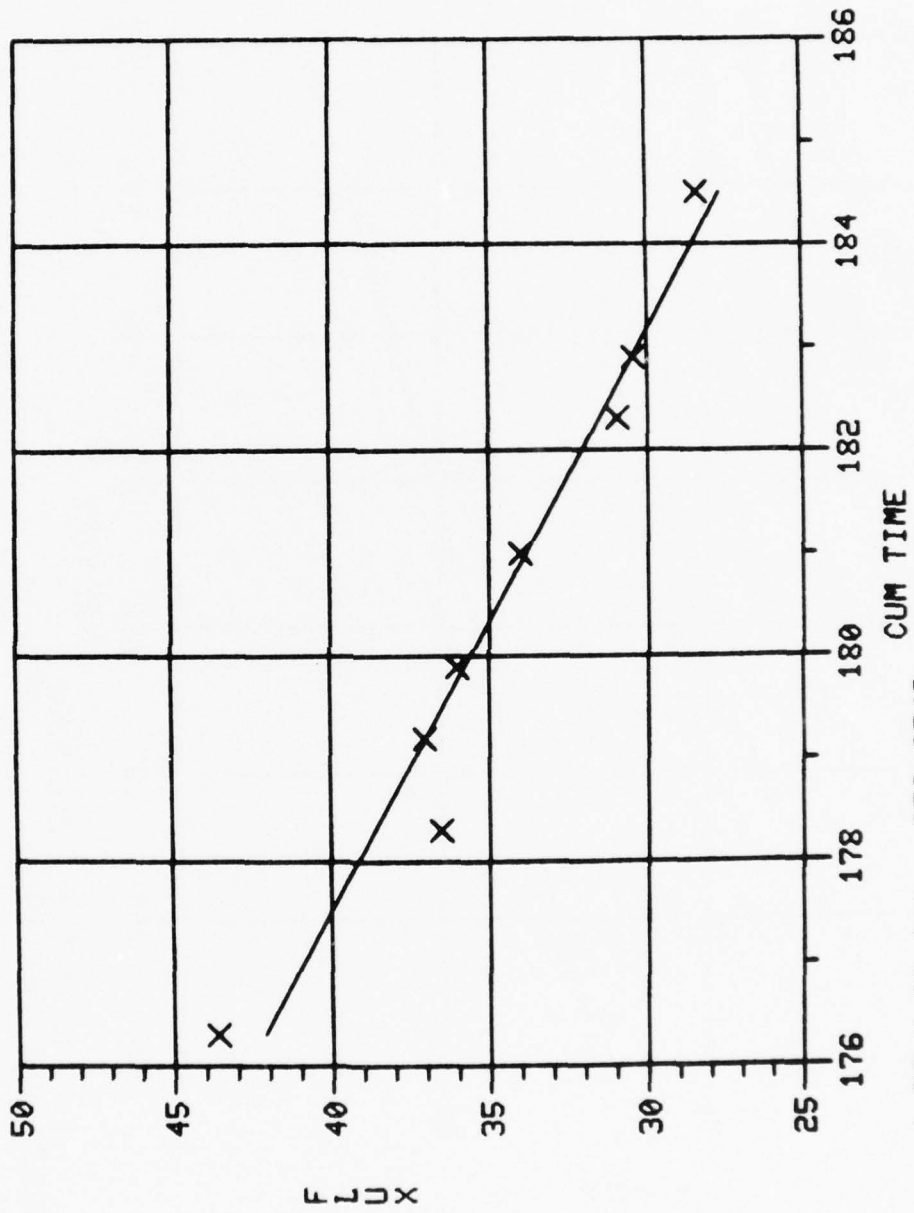

Y = -1.76 X + 353.2748
 SQ MULT CORR COEF IS .954

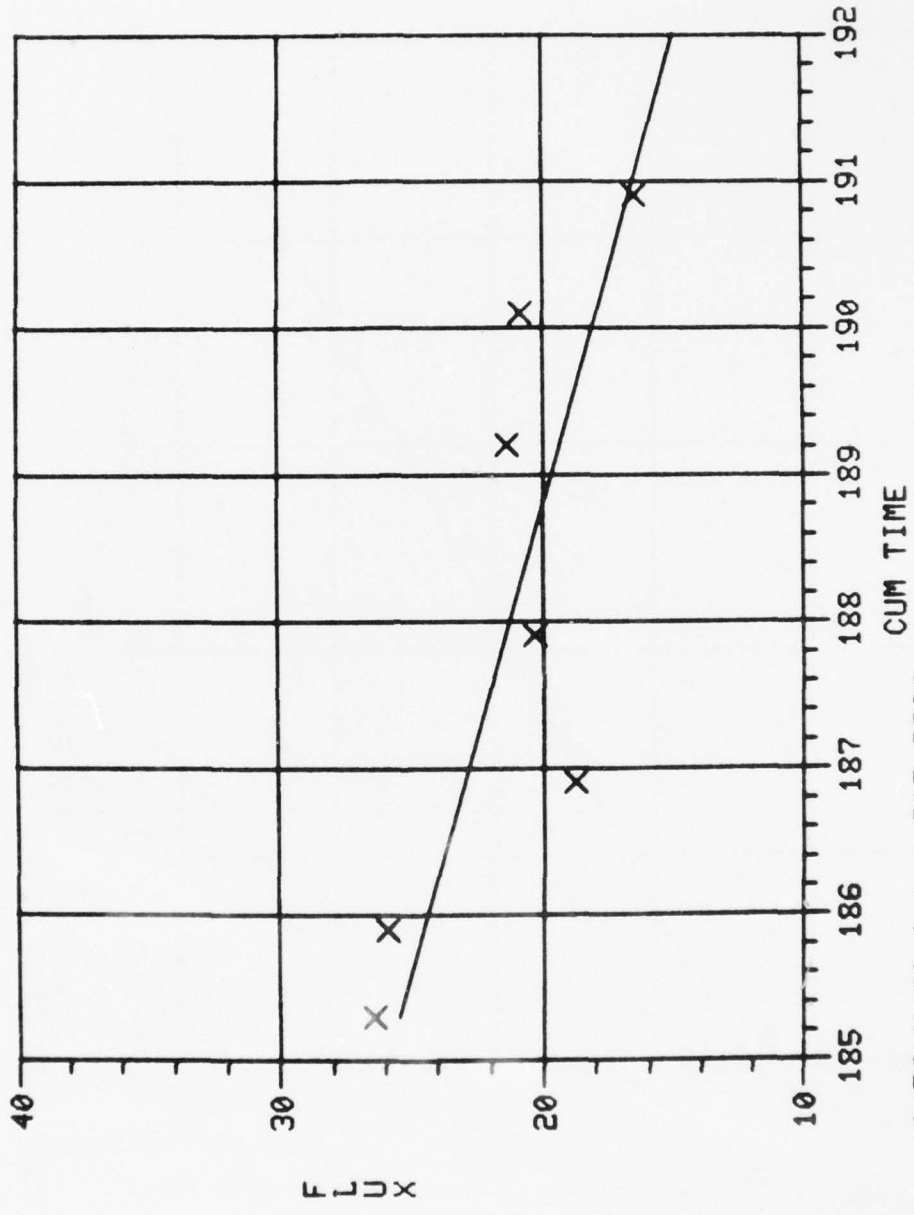

$Y = -1.56 X + 315.3306$
 SQ MULT CORR COEF IS .732

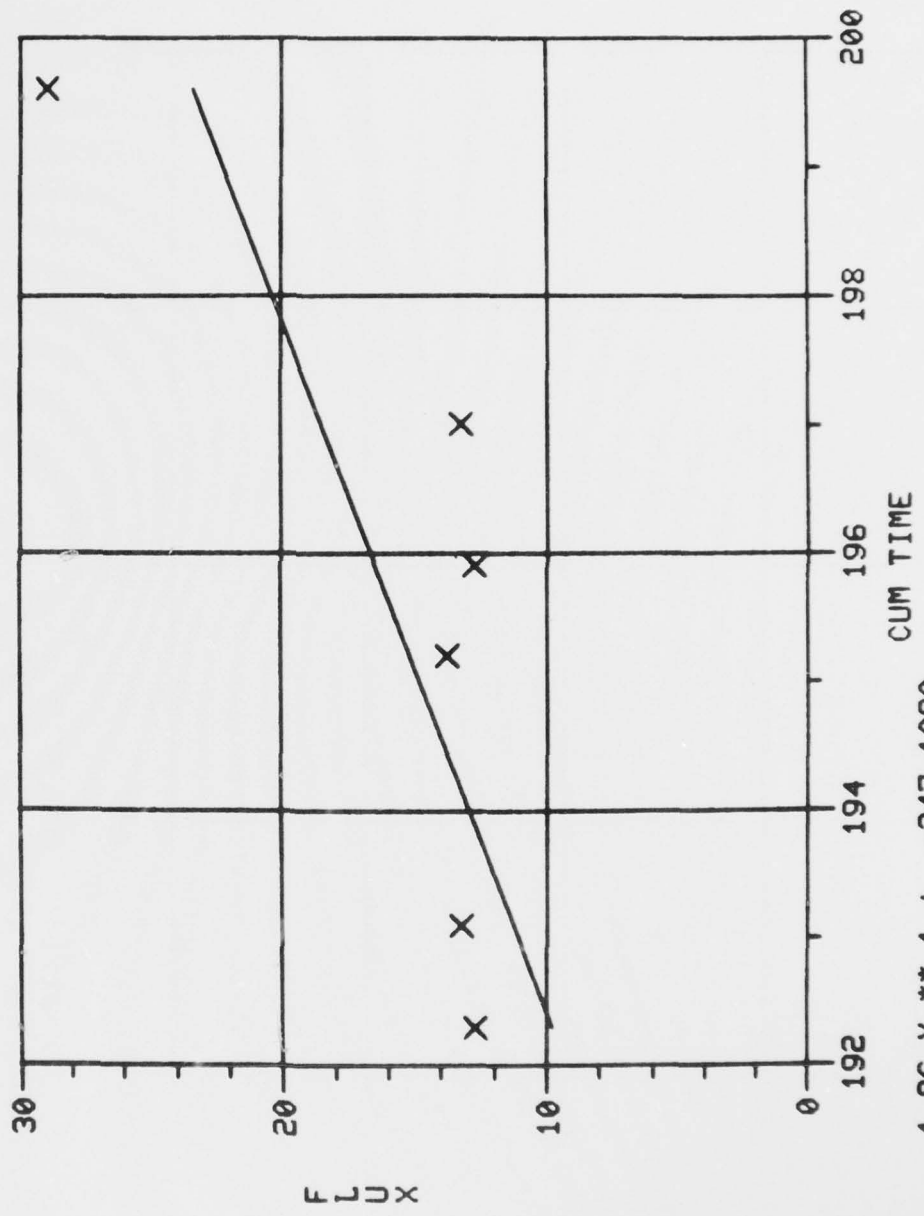

Y= 1.86 X + -347.1080
 SQ MULT CORR COEF IS .580

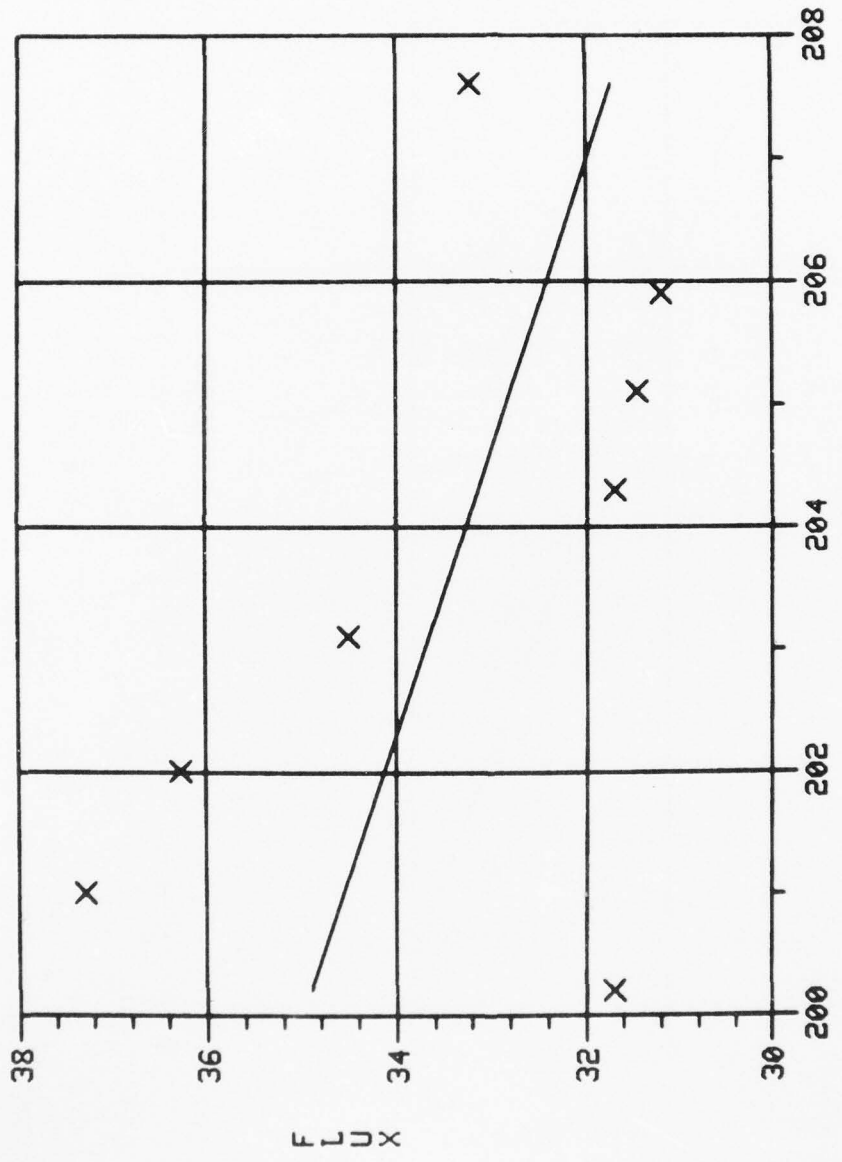

$Y = -.43 X + 120.5776$
 SQ MULT CORR COEF IS .213

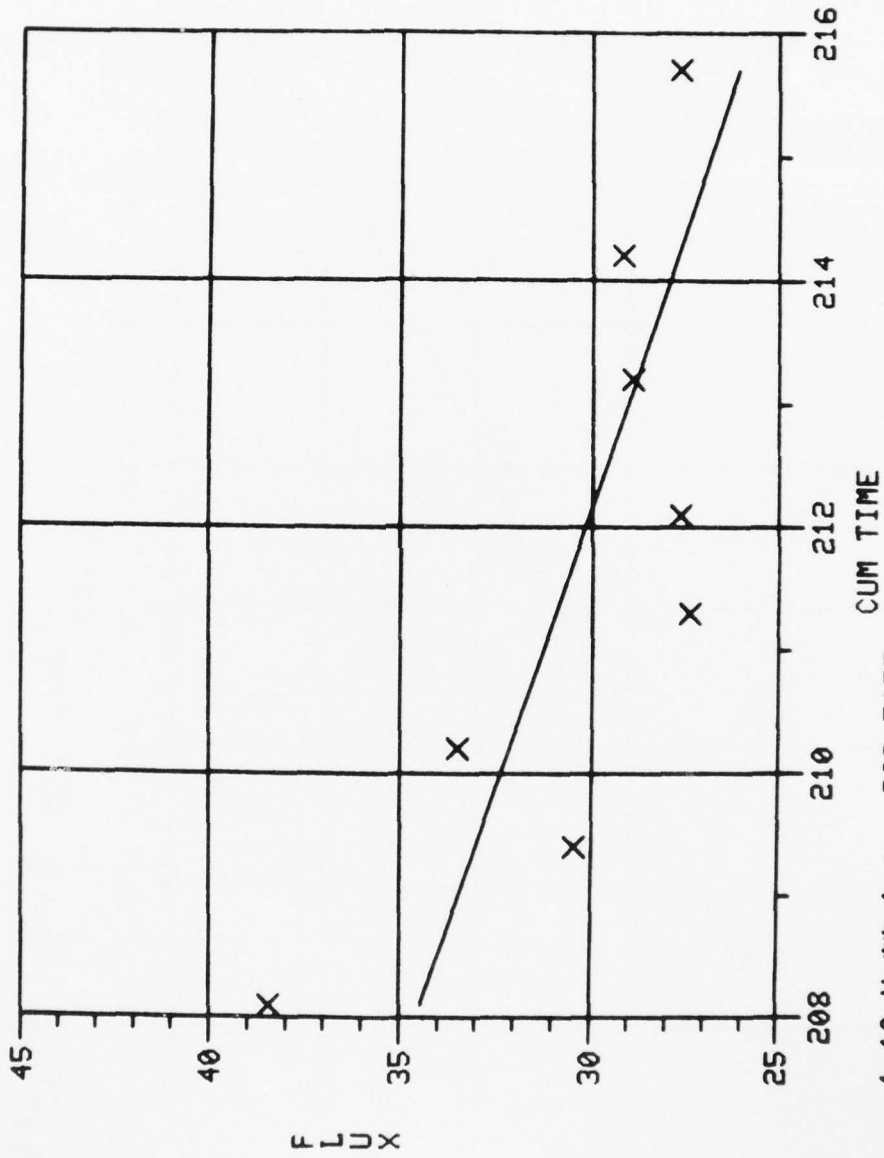

Y = -1.10 X + 263.5177
 SO MULT CORR COEF IS .539

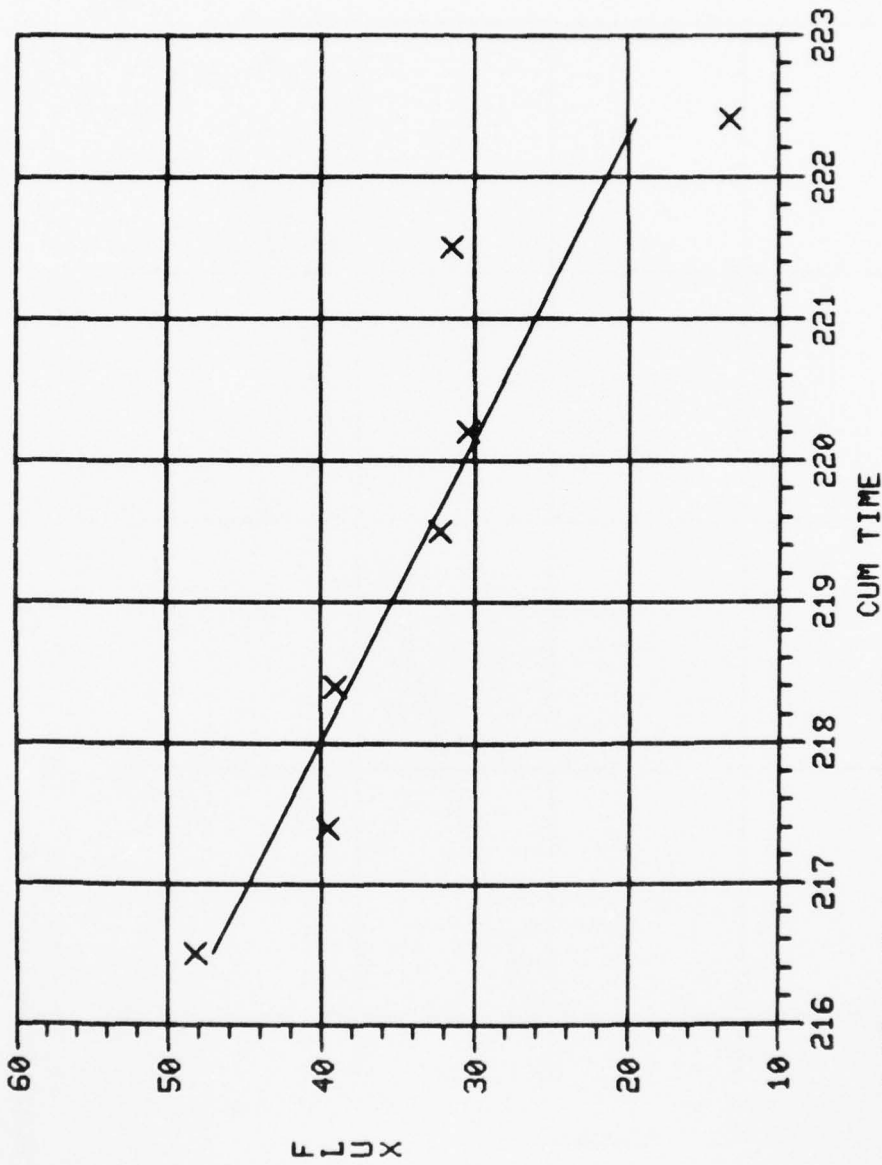

Y = -4.66 X + 1056.8830
 SQ MULT CORR COEF IS .840

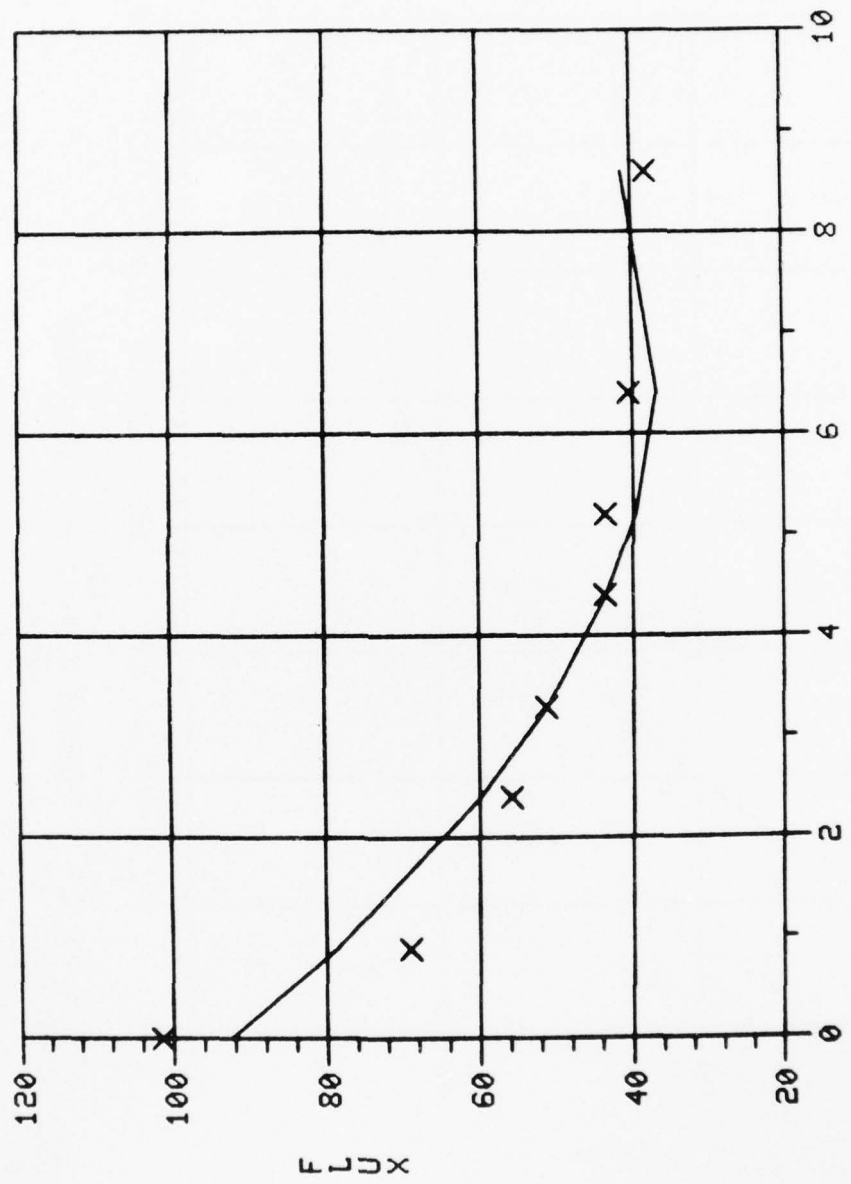

$Y = 1.24 X^{**2} + -16.61 X^{**1} + 92.5680$
 SQ MULT CORR COEF IS .927

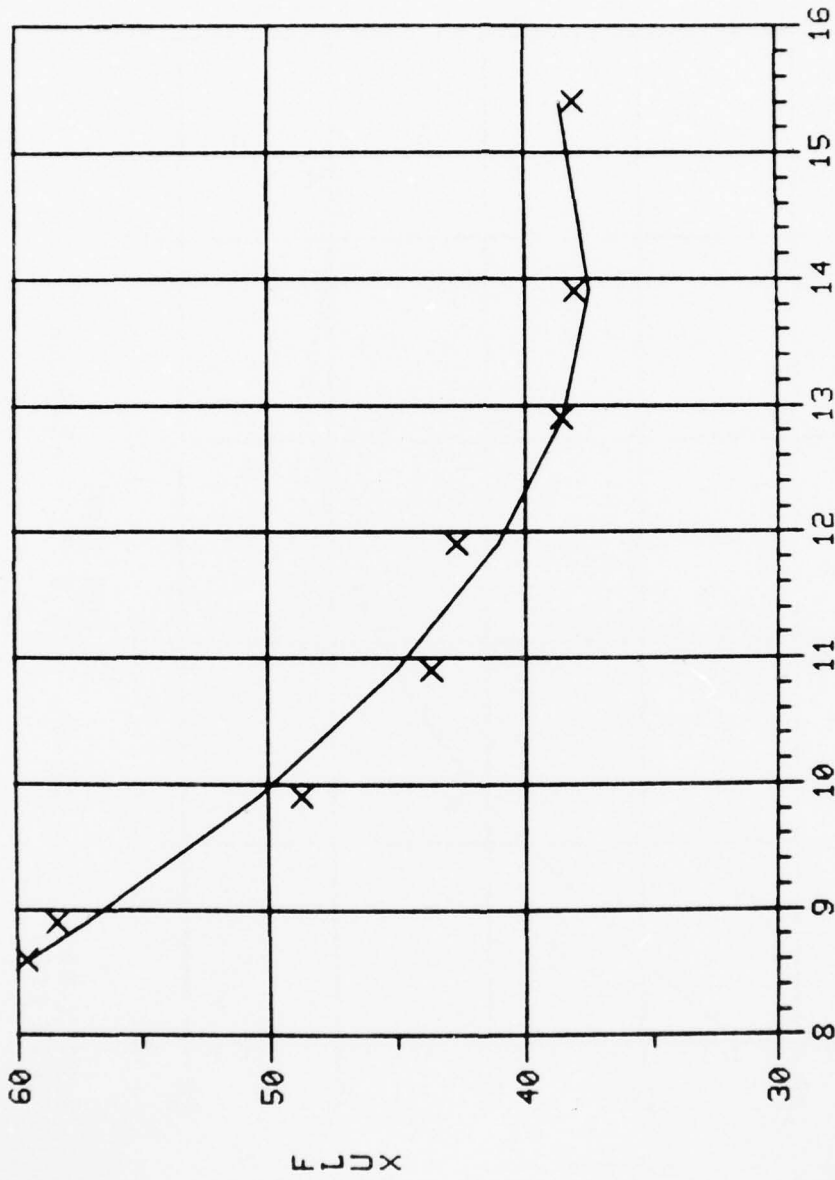

Y= .72 X ** 2 + -20.33 X ** 1 + 181.1239
 SQ MULT CORR COEF IS .983

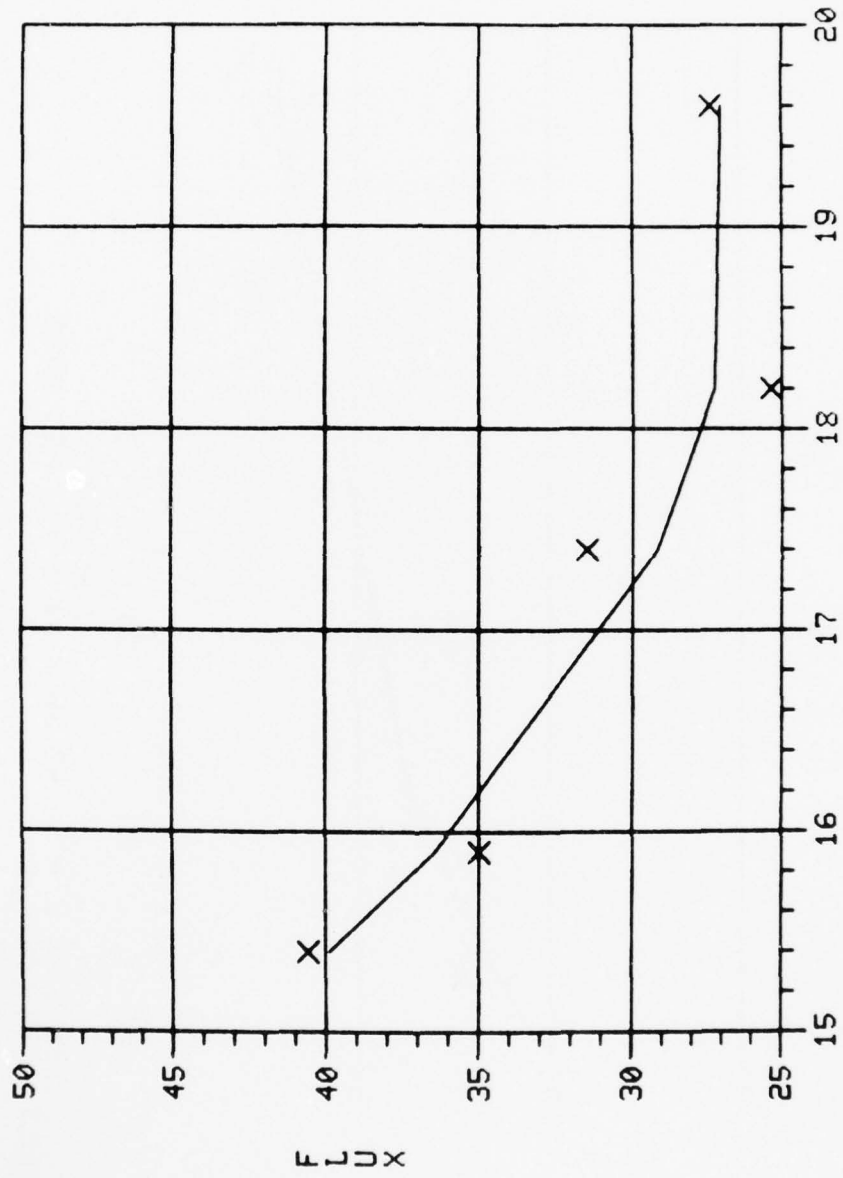

$Y = 1.04 X^{**2} + -39.61 X^{**1} + 402.1783$
 SQ MULT CORR COEF IS .923

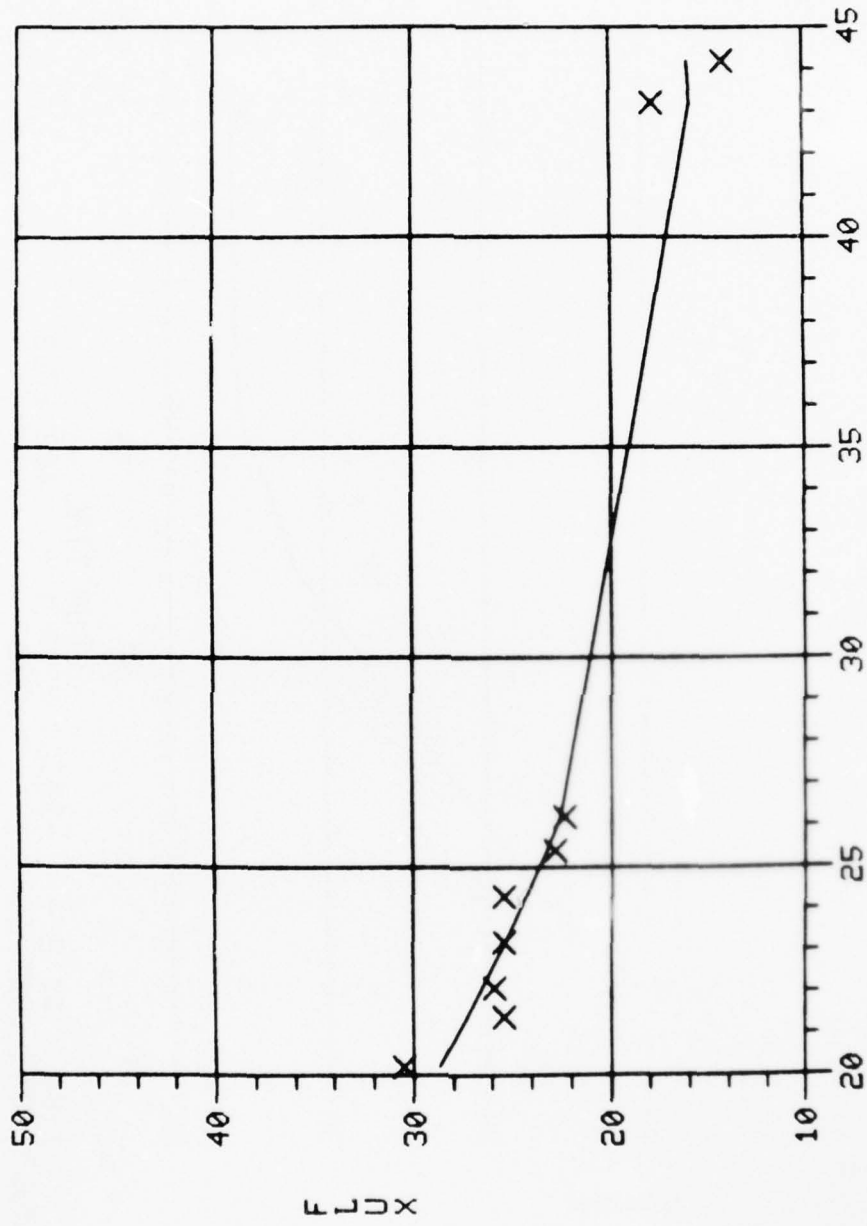

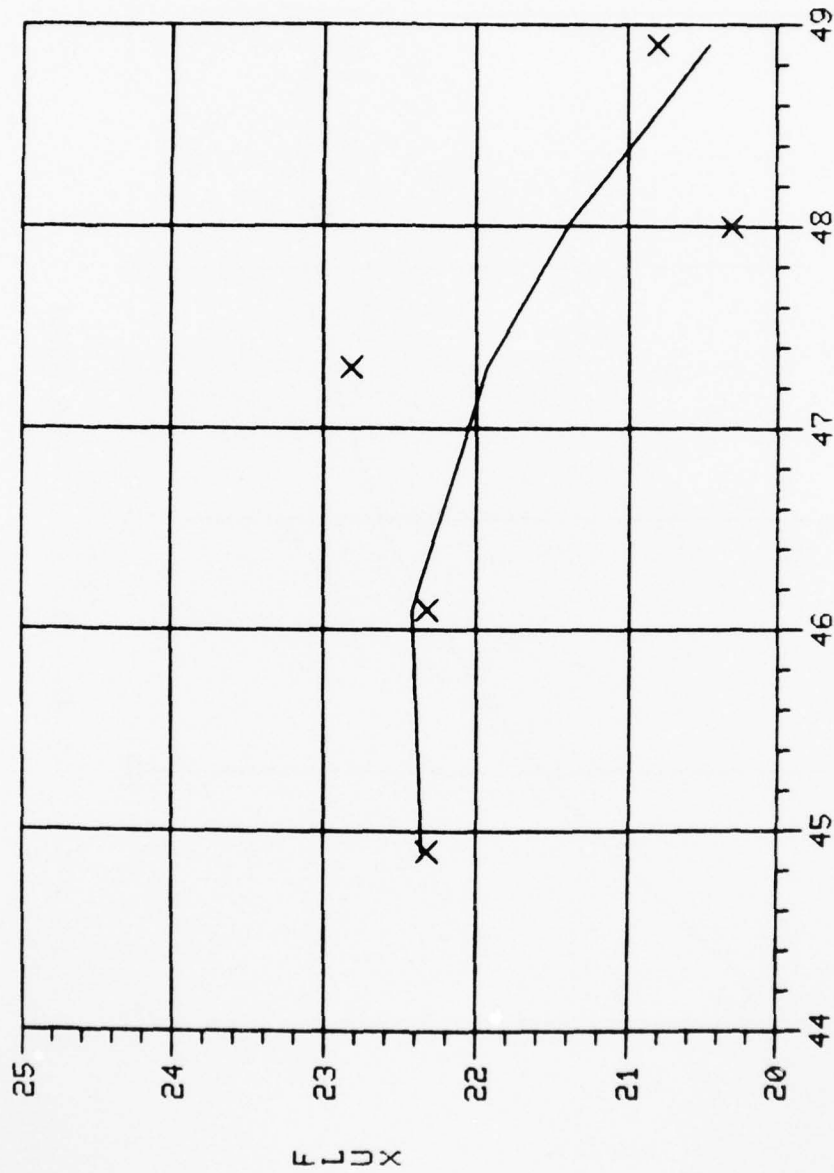

$Y = -.19 X^{**2} + 17.16 X^{**1} + -368.9975$
 SQ MULT CORR COEF IS .555

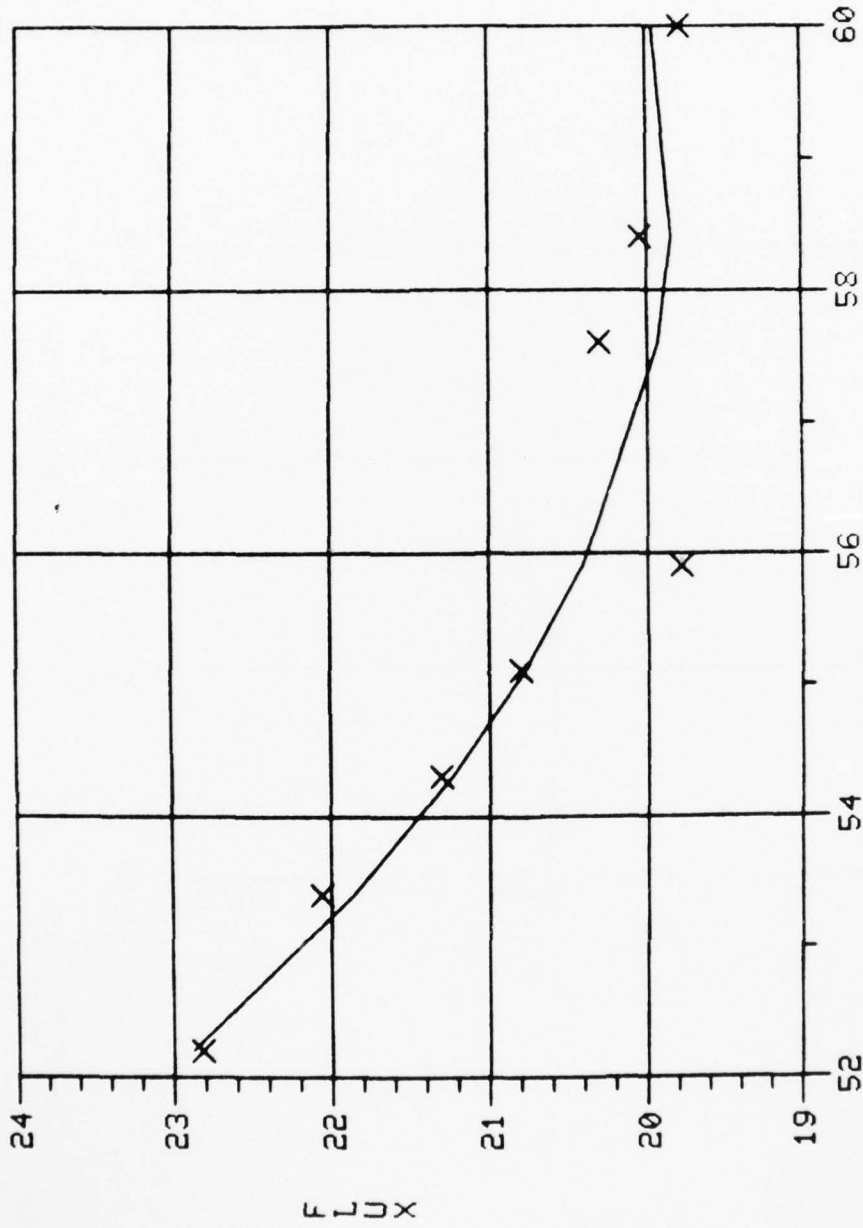

$Y = .07 X^{**2} + -8.40 X^{**1} + 266.4938$
 SO MULT CORR COEF IS .926

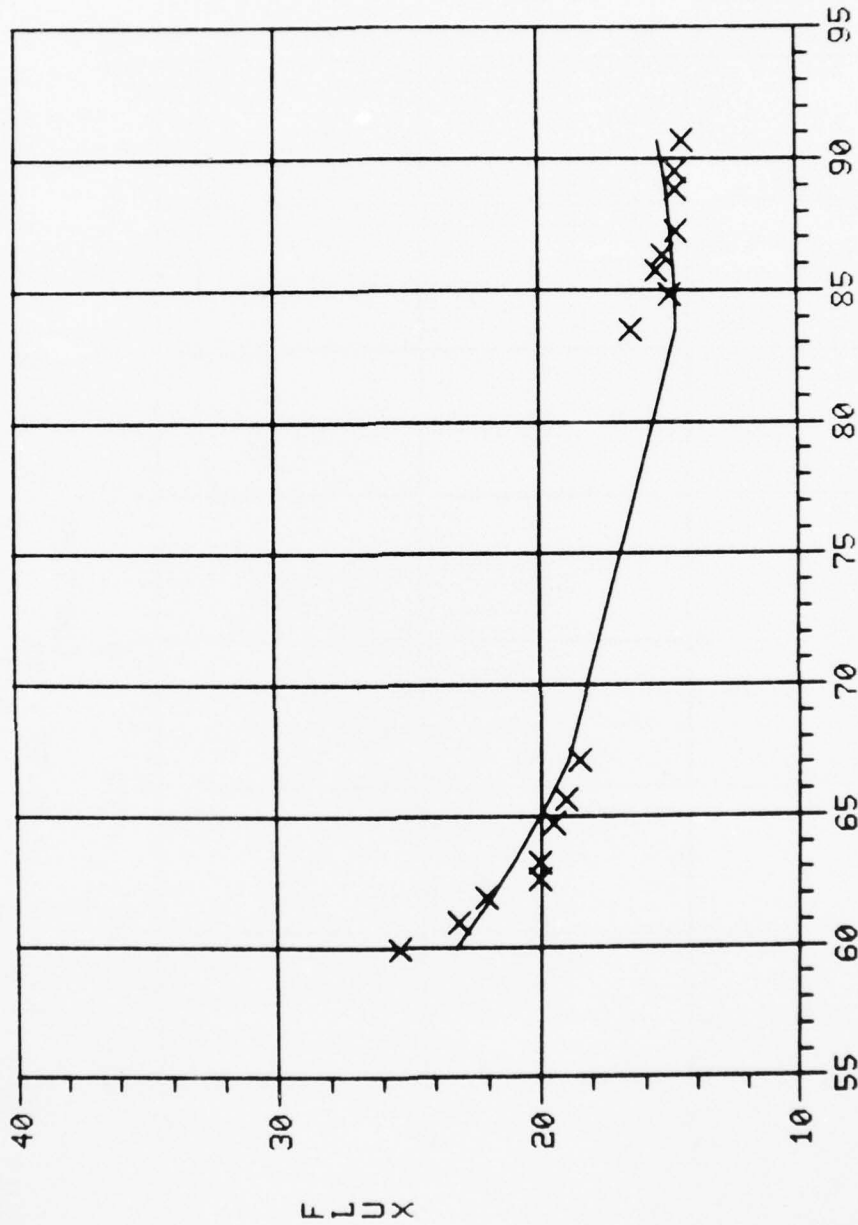

$Y = .01 X^{**2} - 2.43 X^{**1} + 116.9177$
 SO MULT CORR COEF IS .923

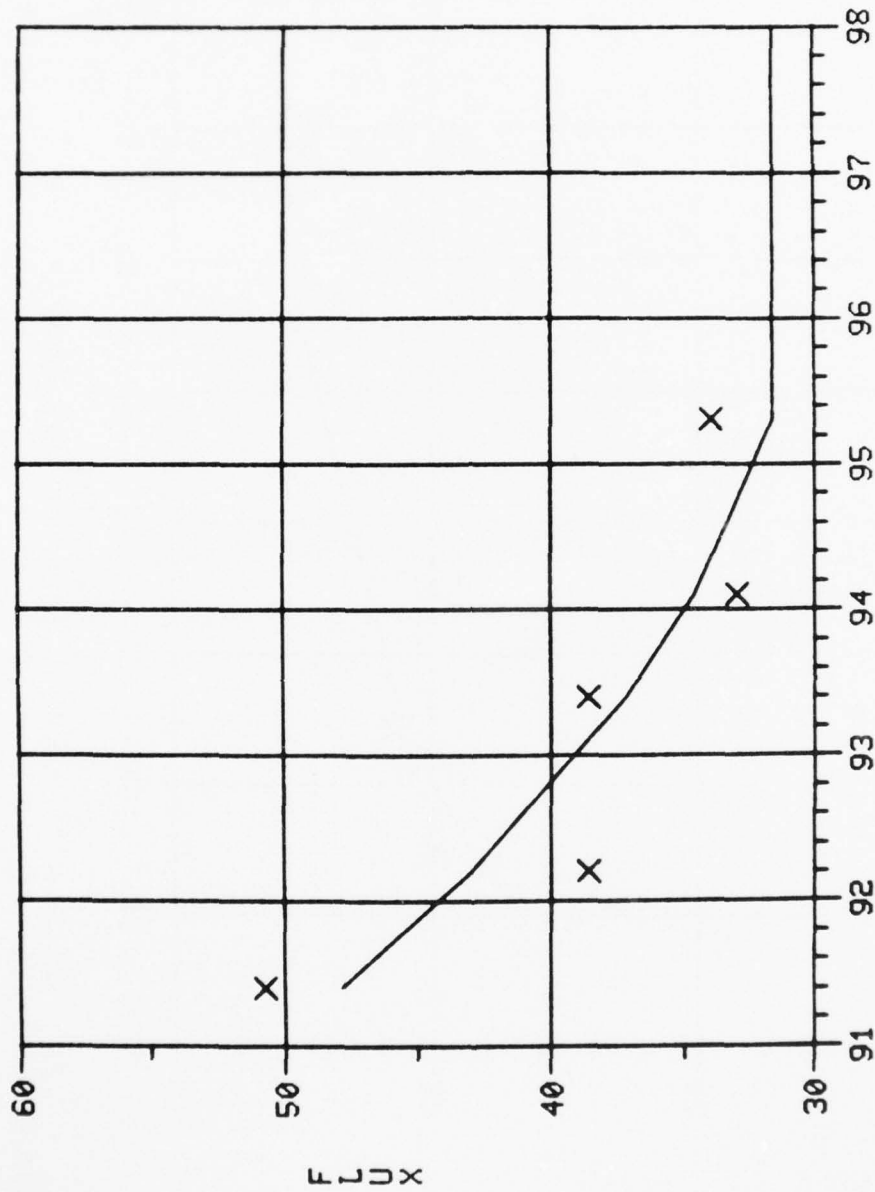

$$Y = .62 X^{**2} - 120.55 X^{**1} + 5857.6522$$
 SQ MULT CORR COEF IS .849

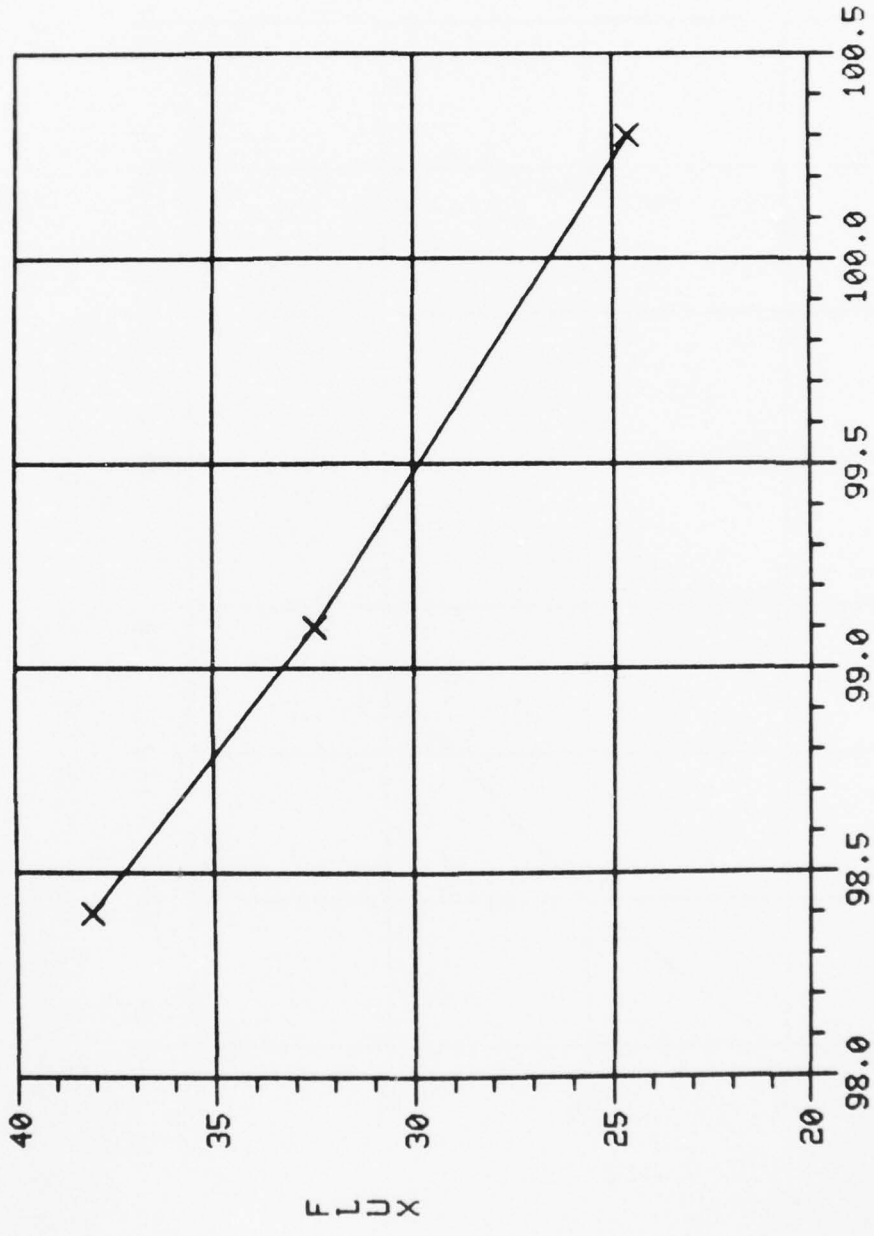

$Y = .75 X^{**} 2 + -155.73 X^{**} 1 + 8117.7090$
 SQ MULT CORR COEF IS 1.000

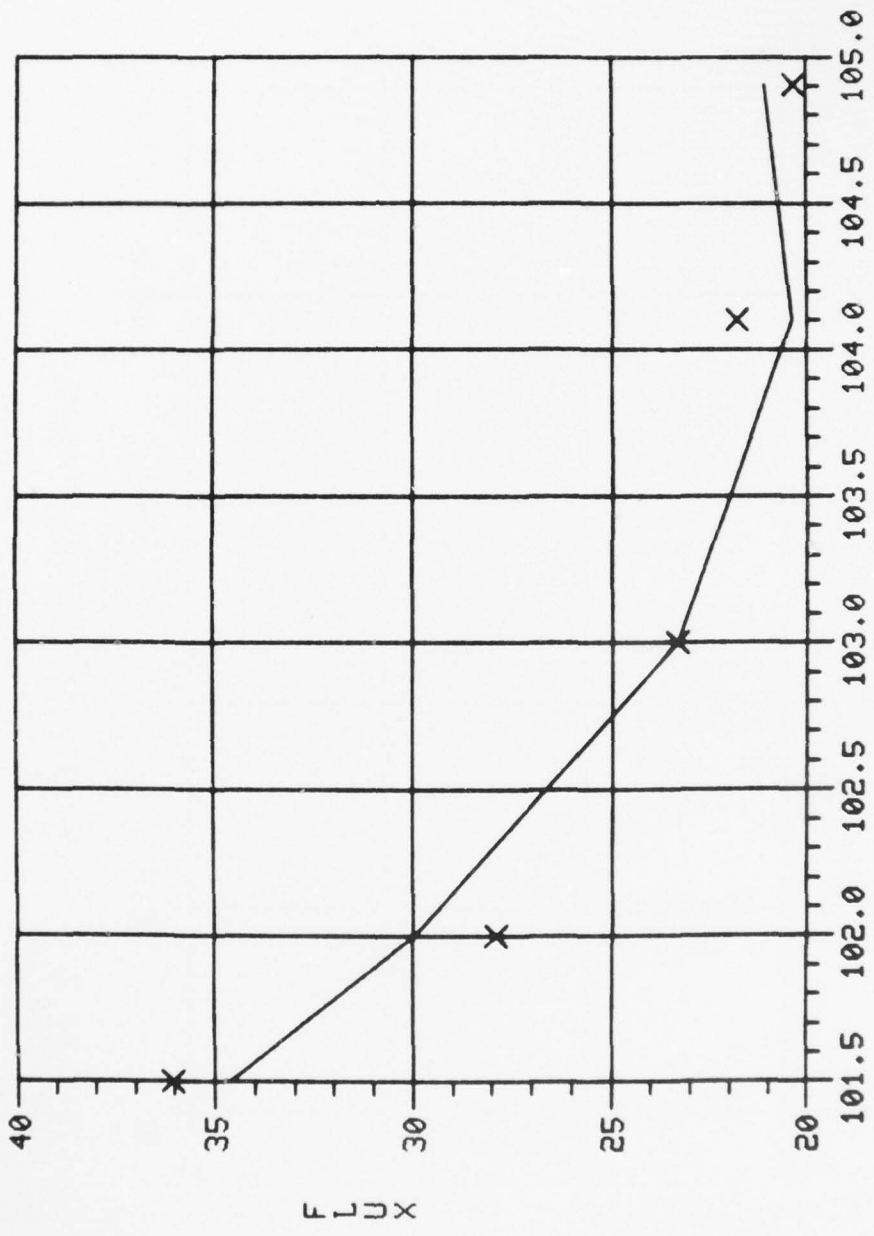

$Y = 1.86 X^2 + -388.19 X + 20258.6437$
 SQ MULT CORR COEF IS .946

AD-A043 716

ARMY MOBILITY EQUIPMENT RESEARCH AND DEVELOPMENT COMM--ETC F/6 13/2
PROCESS DESIGN FOR TREATING SHOWER WASTEWATER BY ULTRAFILTRATIO--ETC(U)
JUN 77 D S LENT

UNCLASSIFIED

MERADCOM-2212

NL

2 OF 2

AD
A043716

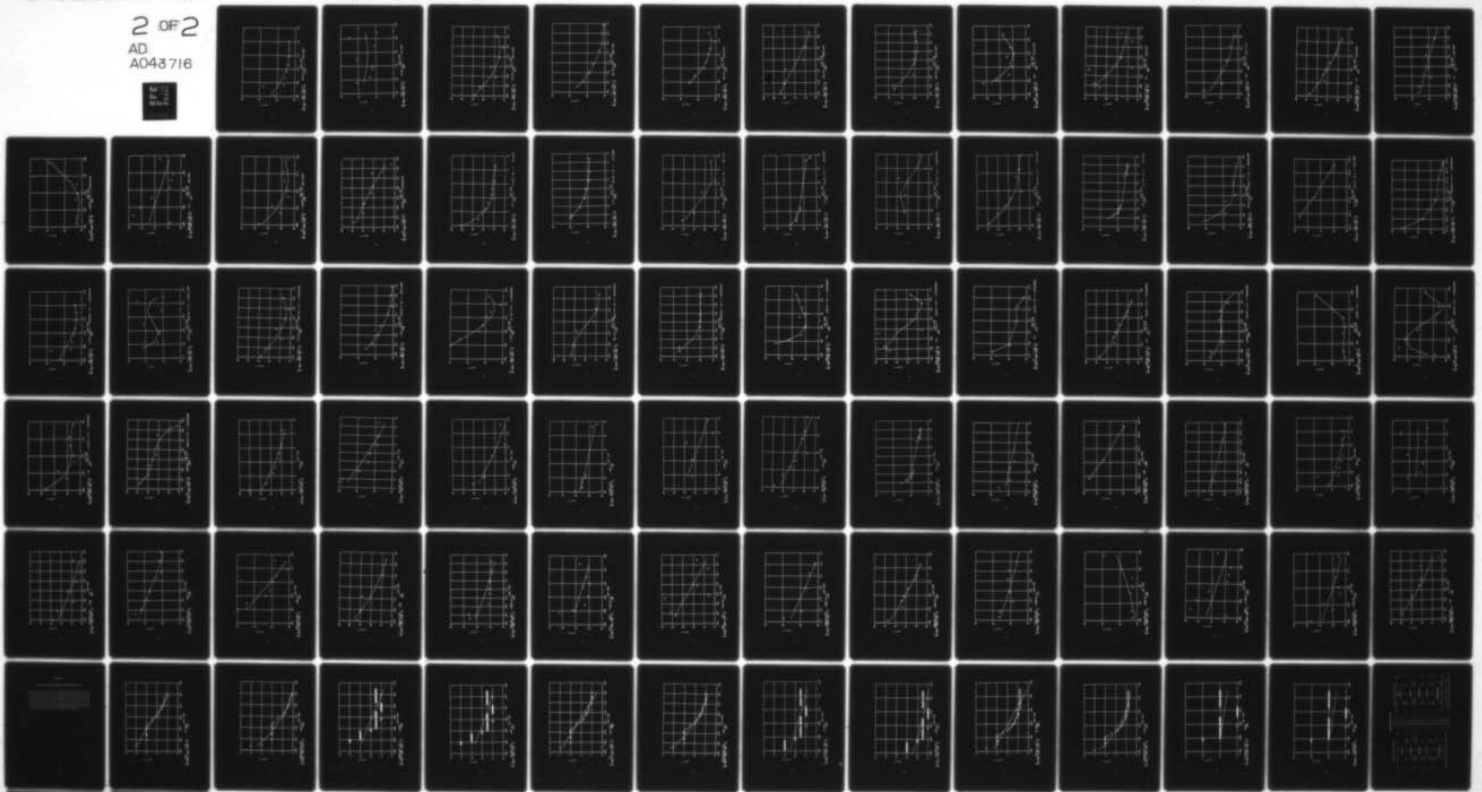

END
DATE
FILMED

9-77

DDC

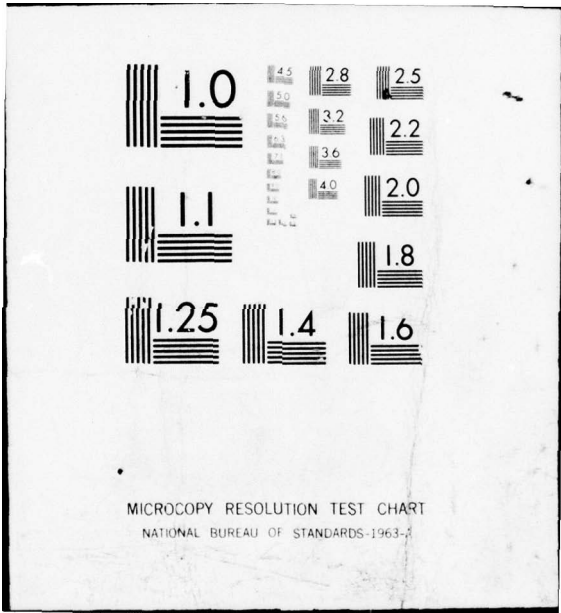

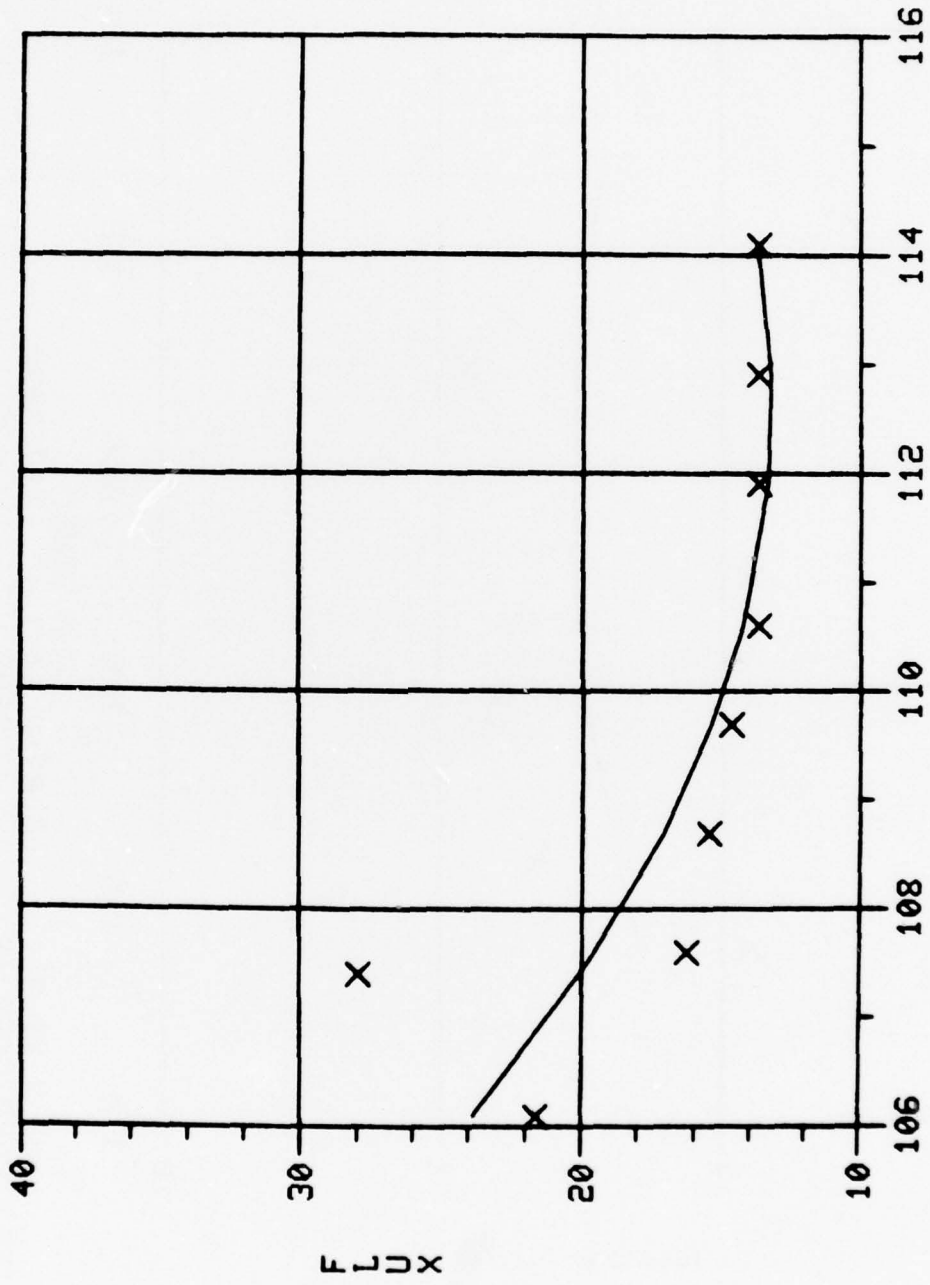

$$Y = .25 X^{**2} + -55.32 X^{**1} + 3129.5067$$
 SQ MULT CORR COEF IS .573

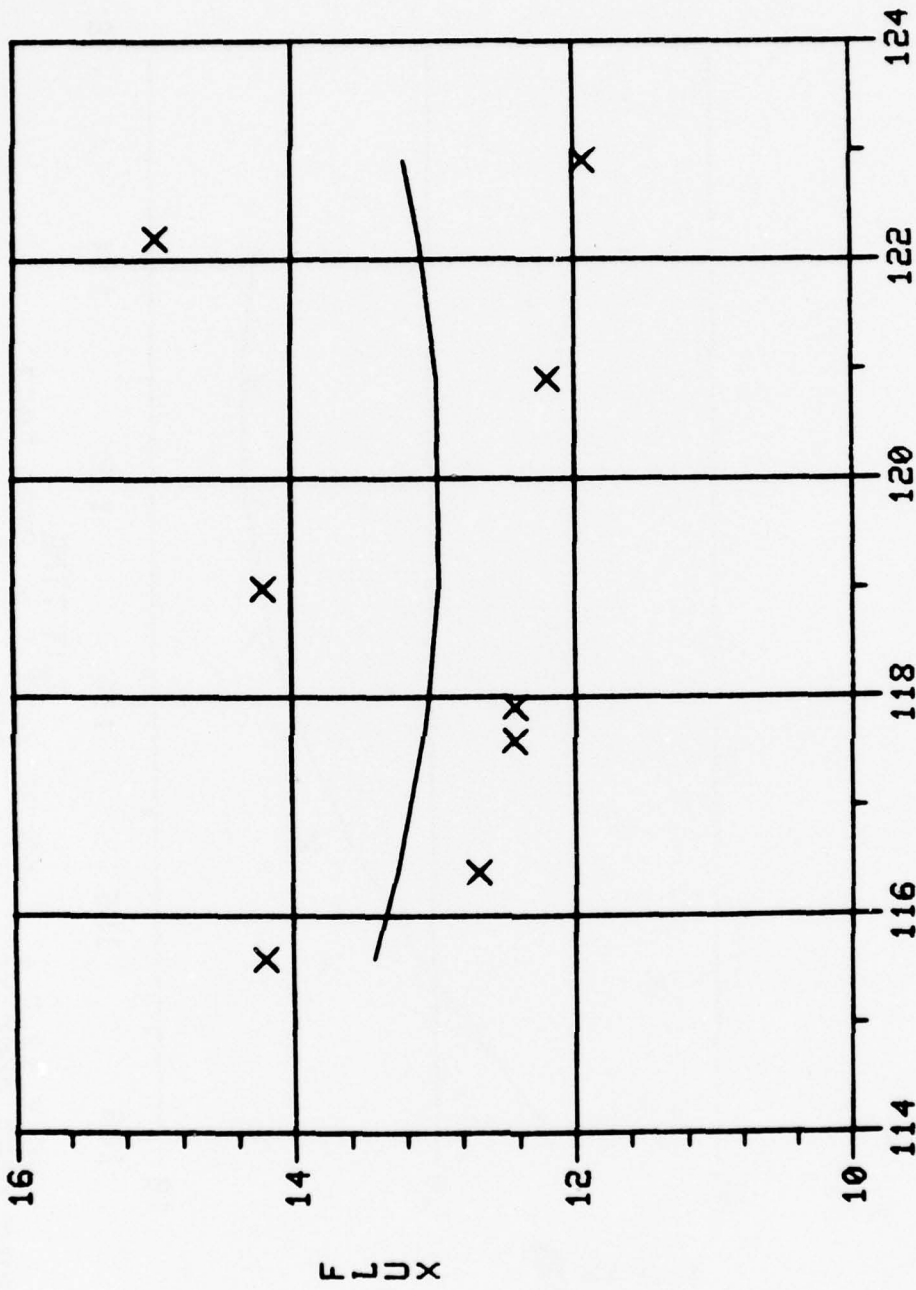

$$Y = .03 X^2 + -6.67 X + 412.3074$$
 SQ MULT CORR COEF IS .020

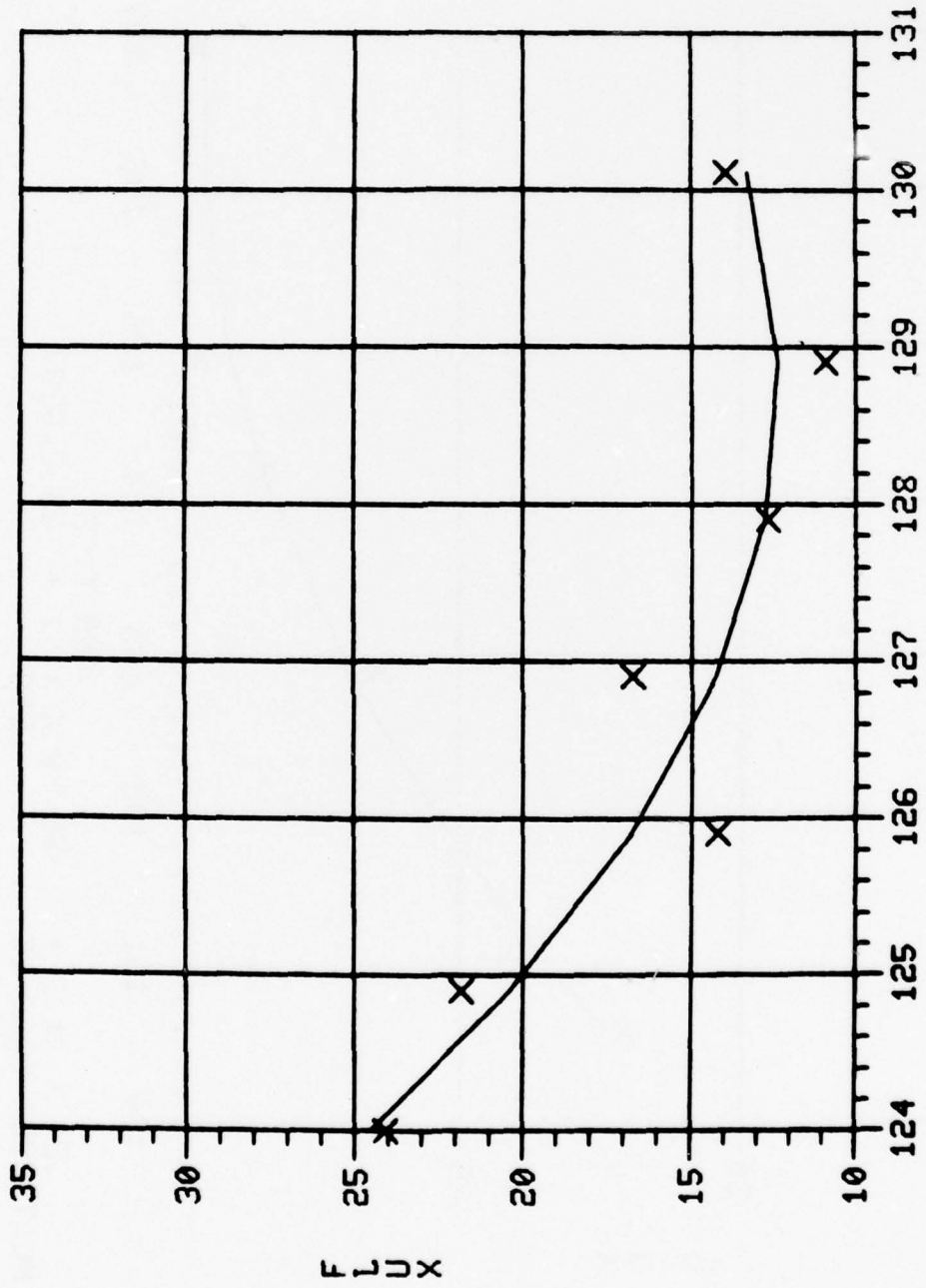

$Y = .53 X^{**2} + -137.25 X^{**1} + 8849.6969$
 SQ MULT CORR COEF IS .876

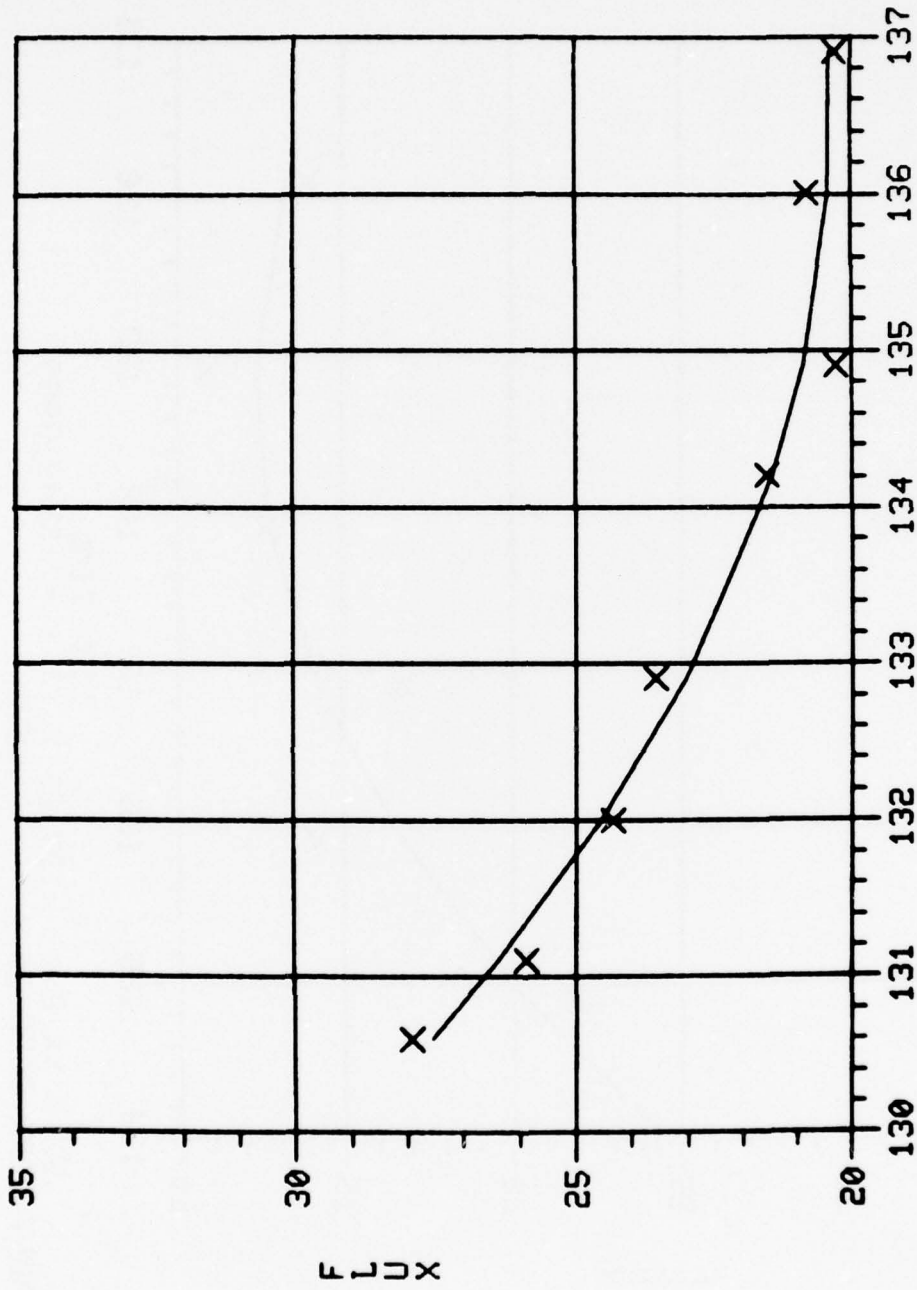

$$Y = .21 X^2 + -56.39 X + 3868.9387$$
 SQ MULT CORR COEF IS .978

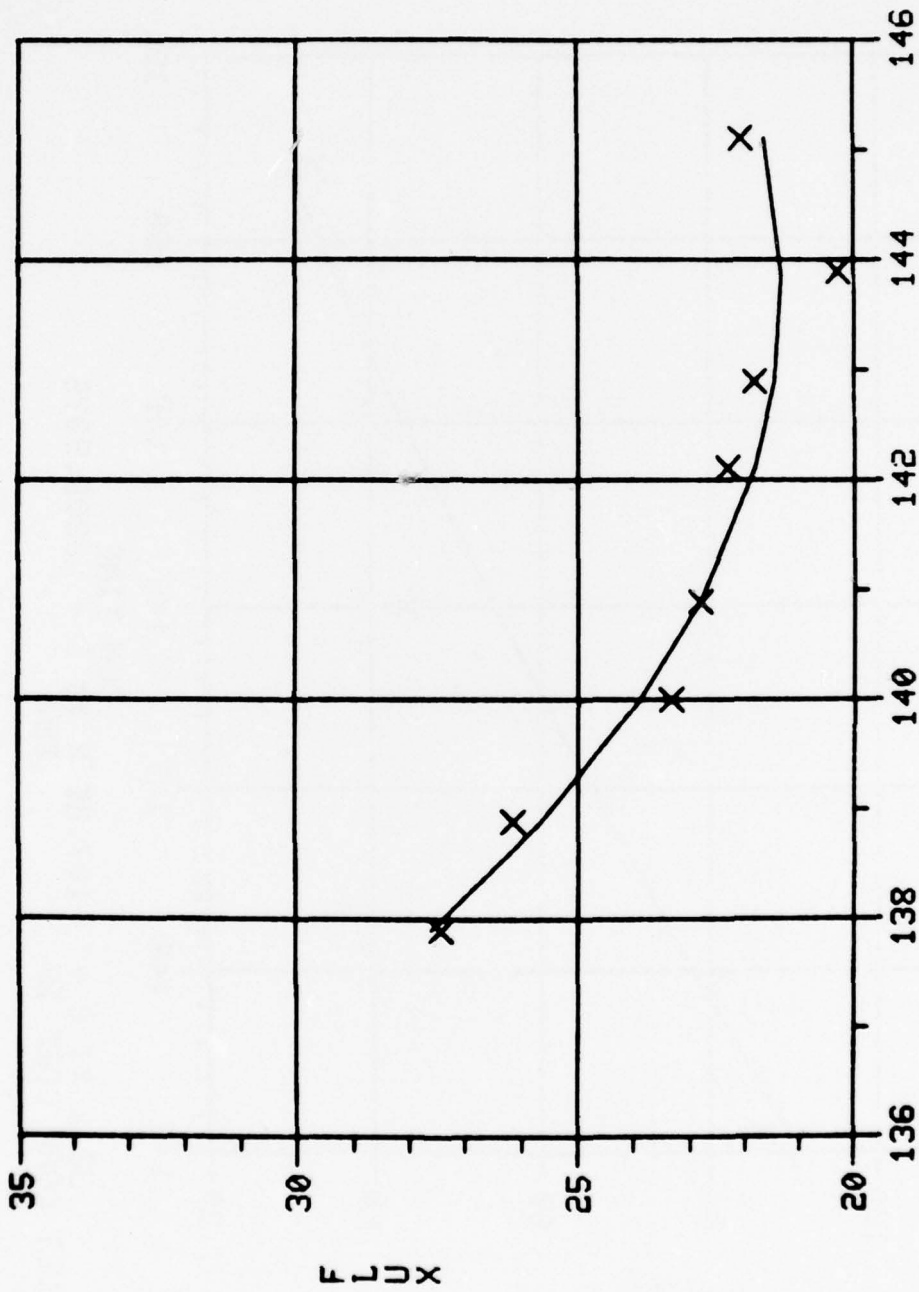

$$Y = .18 X^{**2} + -52.43 X^{**1} + 3789.8418$$
 SQ MULT CORR COEF IS .943

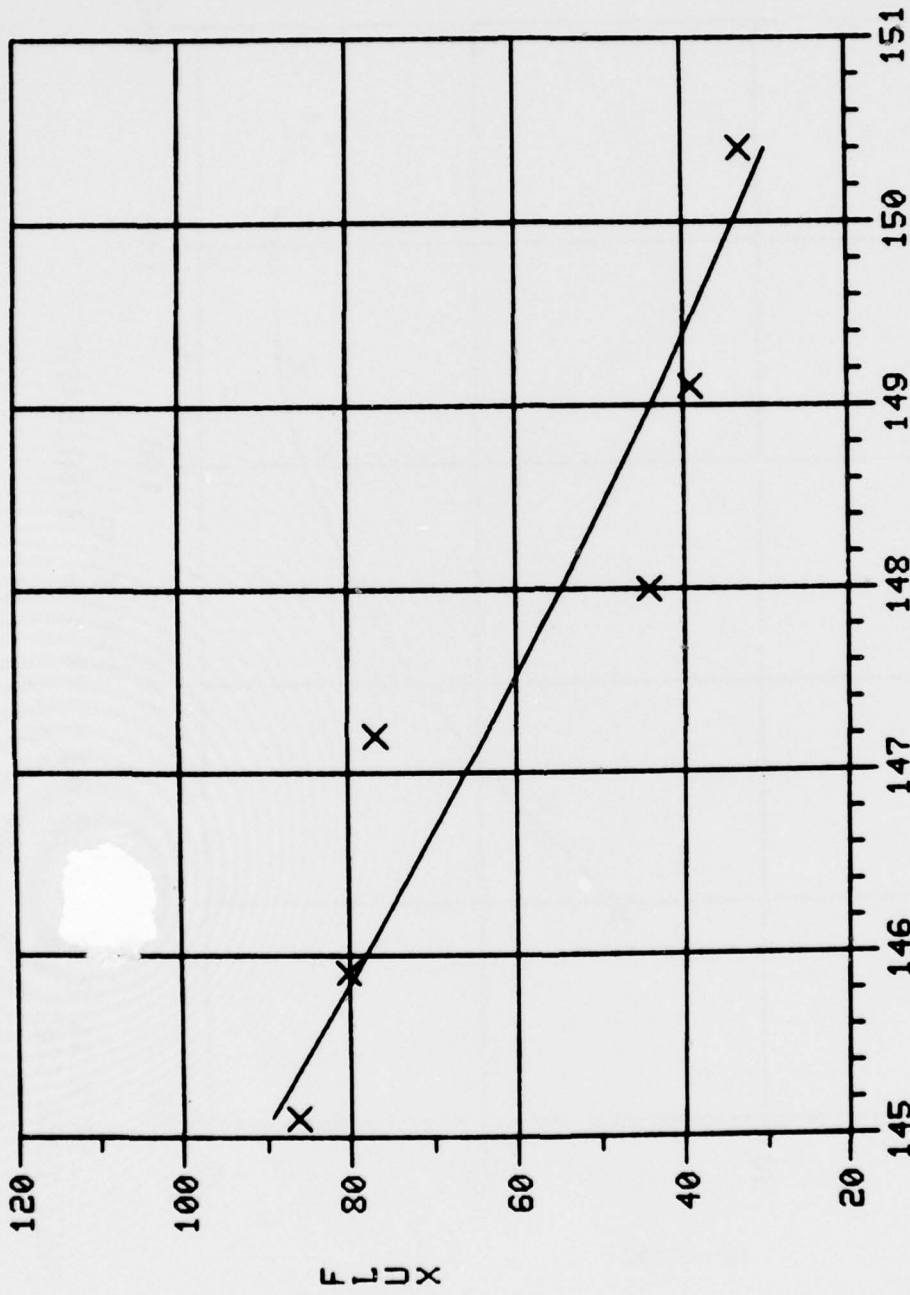

$Y = .32 X^{**2} + -107.25 X^{**1} + 8809.9075$
 SQ MULT CORR COEF IS .887

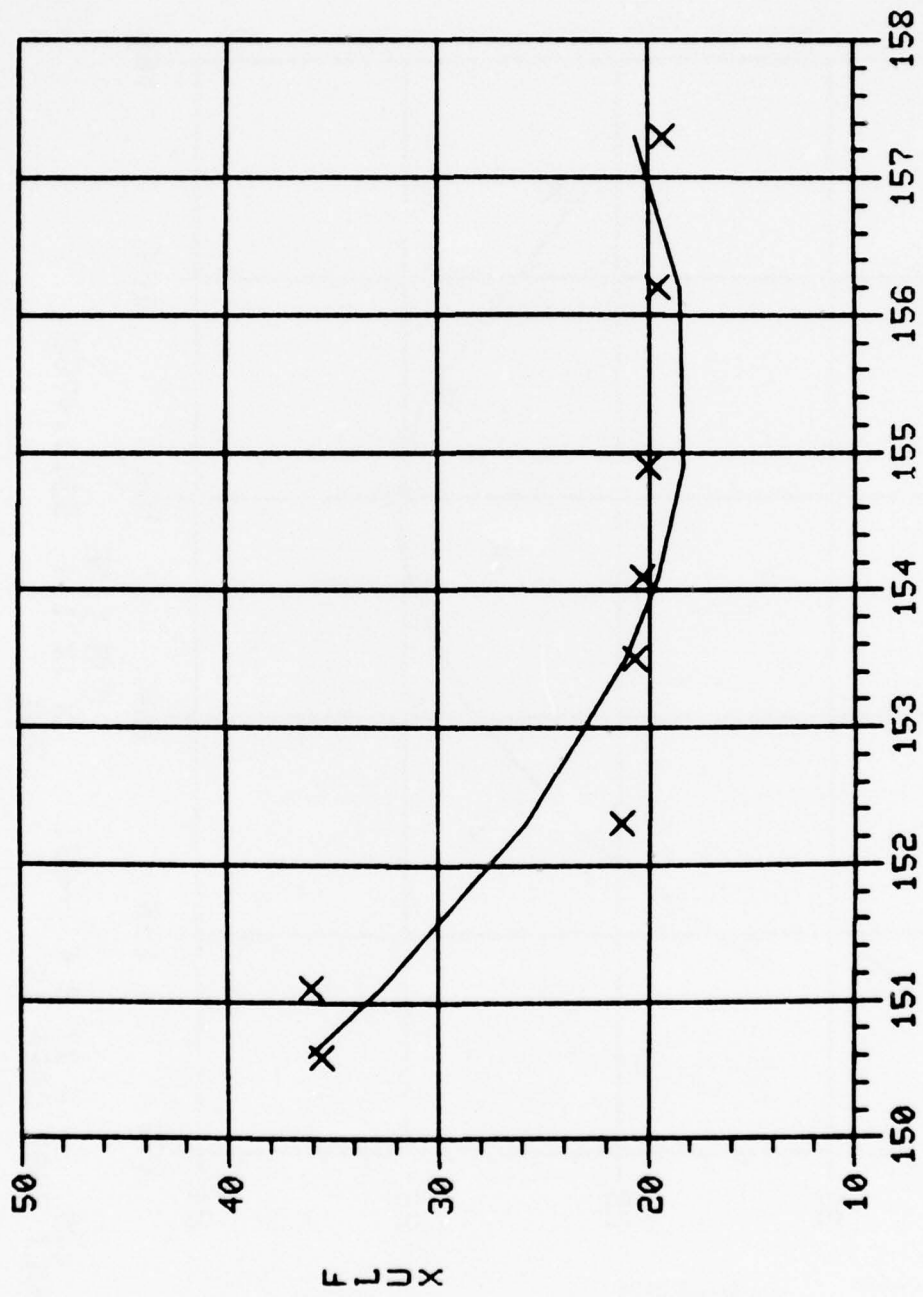

$Y = .76 X^{**2} + -235.10 X^{**1} + 18295.9892$
 SQ MULT CORR COEF IS .896

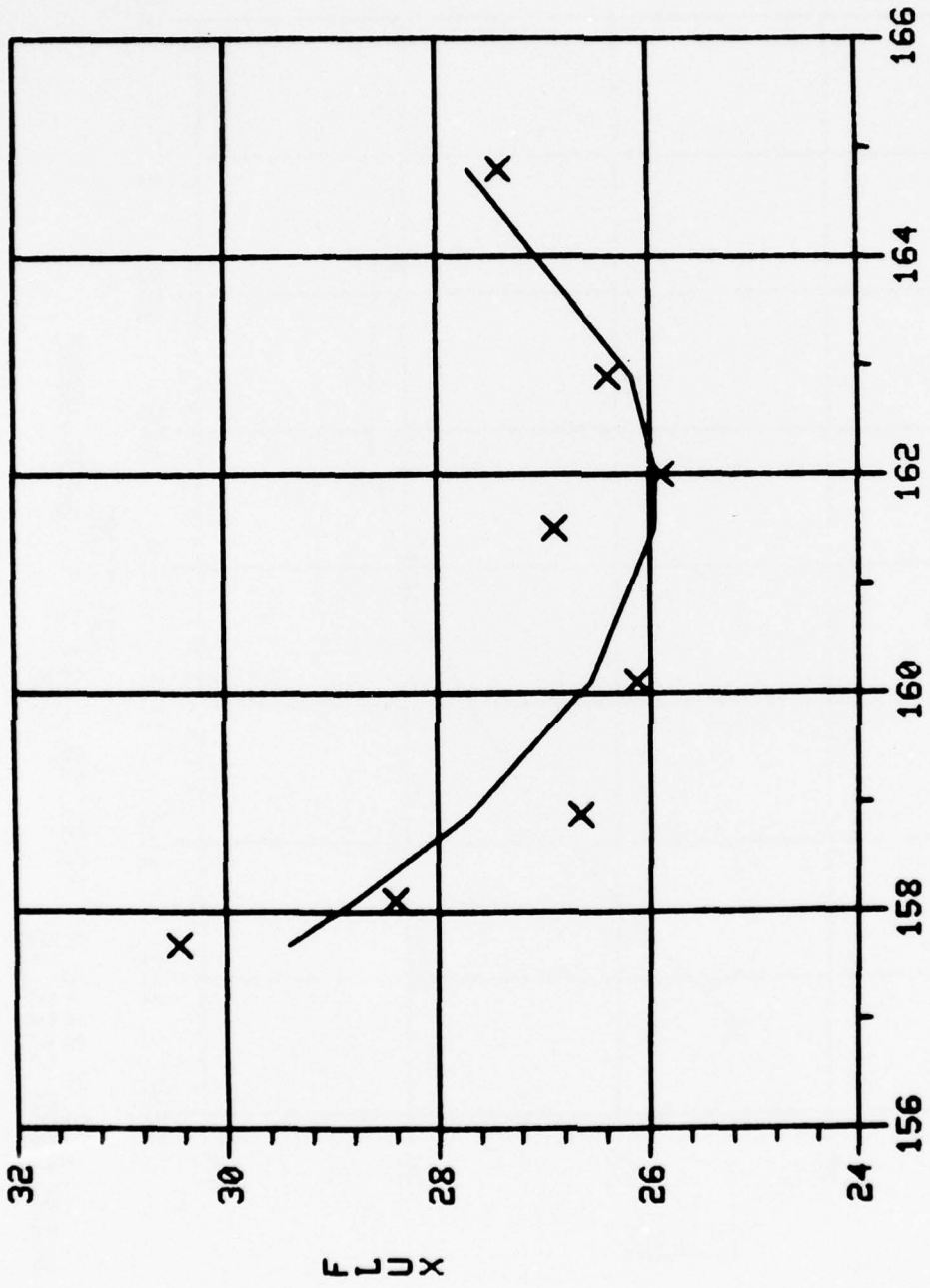

$Y = .20 X^{**} 2 + -65. X^{**} 1 + 5319.4702$
 SQ MULT CORR COEF IS .782

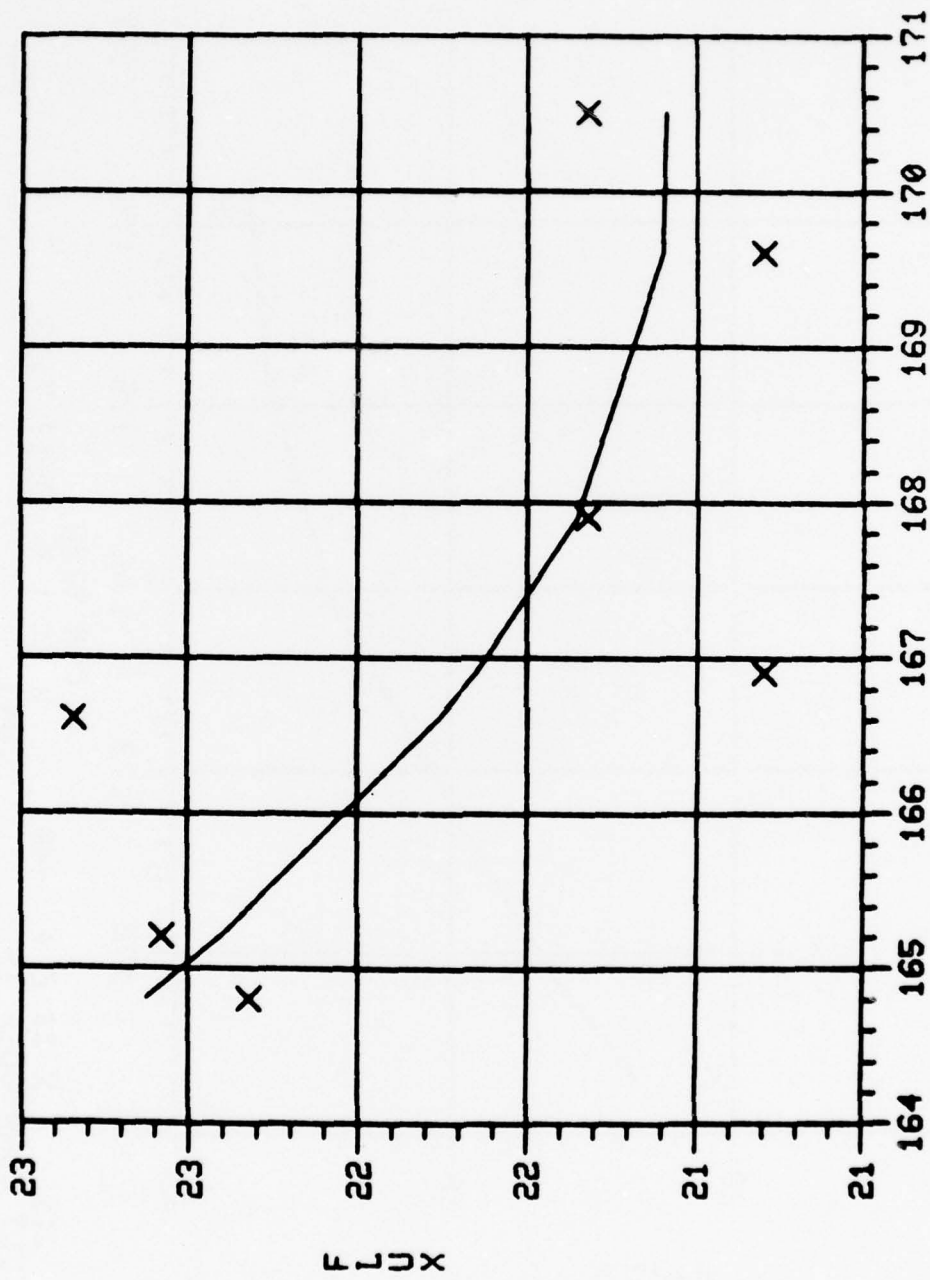

Y= .55E-01 X XX 2 + -19. X XX 1 + 1600.9817
 SQ MULT CORR COEF IS .506

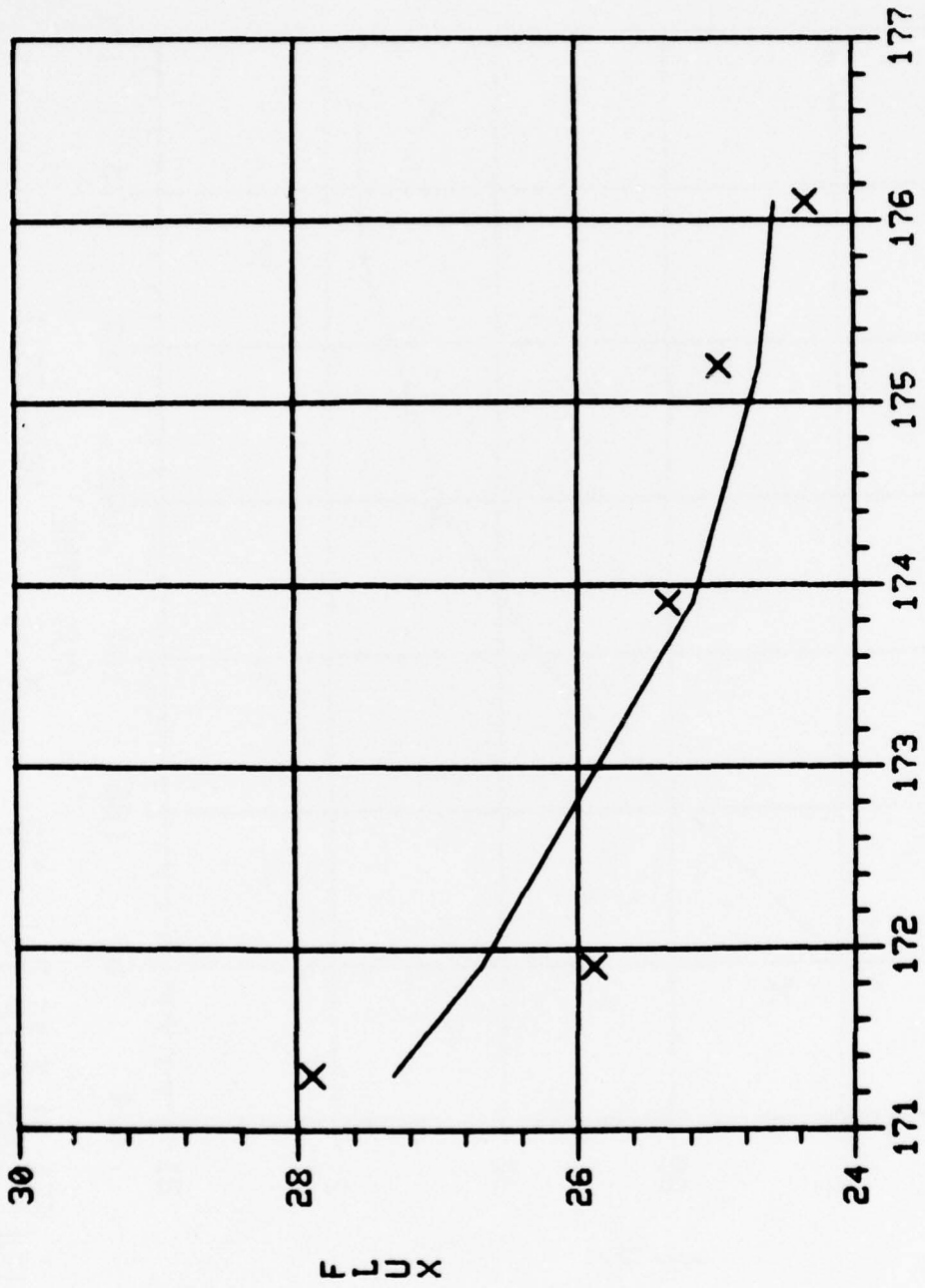

$Y = .11 X^2 + -40. X + 3517.7113$
 SQ MULT CORR COEF IS .843

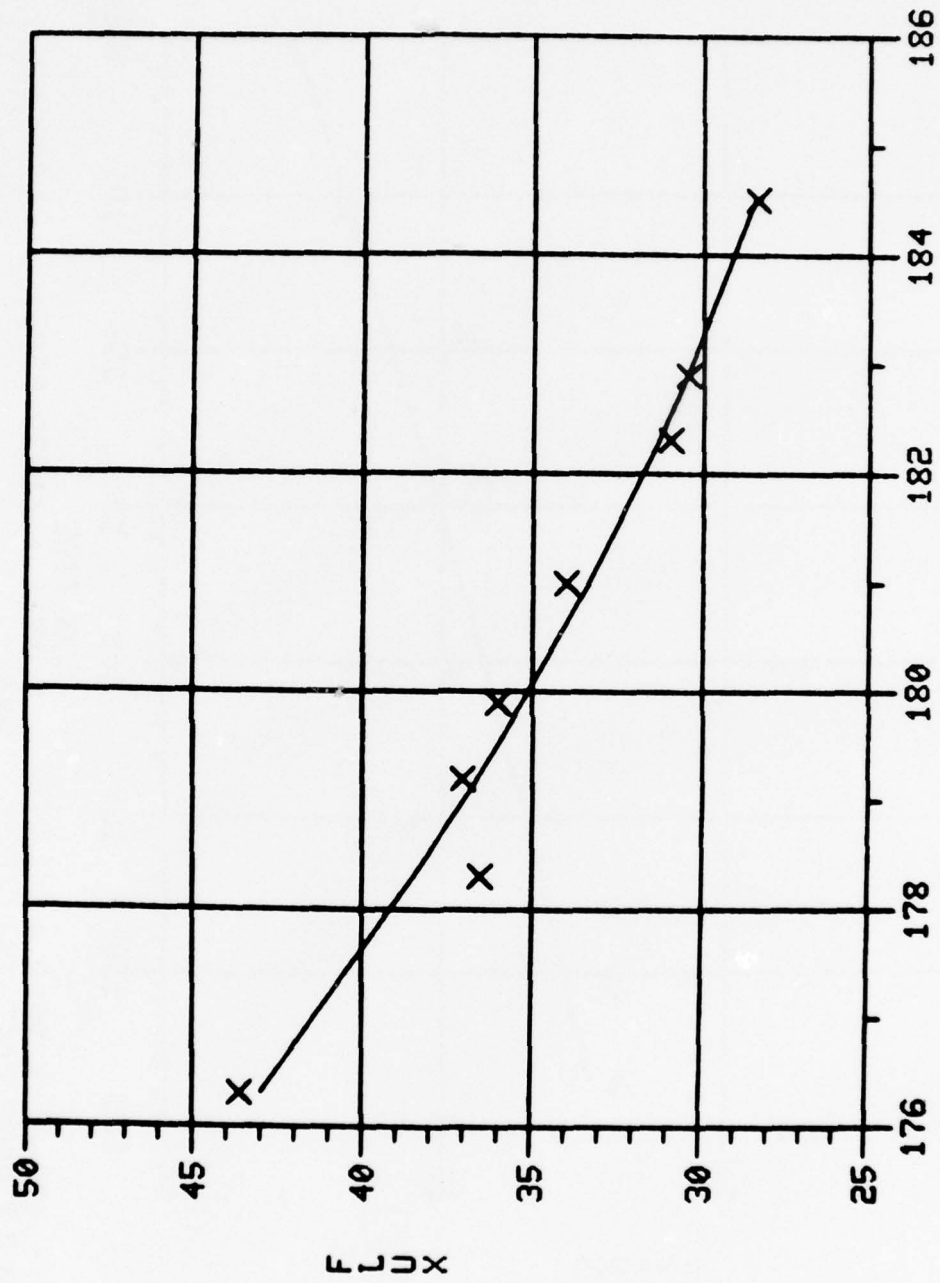

$Y = .81E-01 X^2 + -31.$
 SQ MULT CORR COEF IS .967
 CUM TIME X ** 1 + 2995.6225

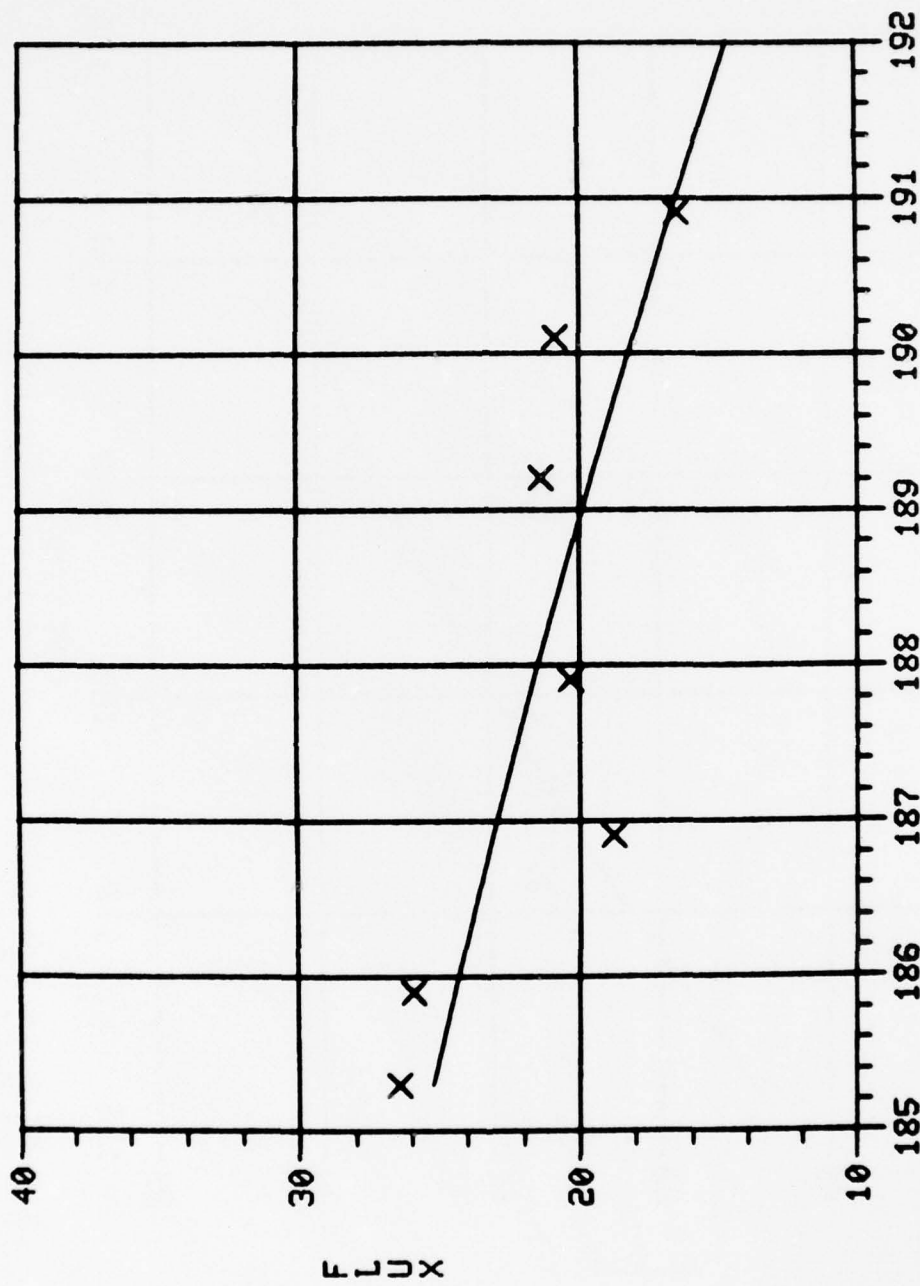

Y = -.47E-01 X XX 2 + 16. X XX 1 + -1339.8305
 SQ MULT CORR COEF IS .734

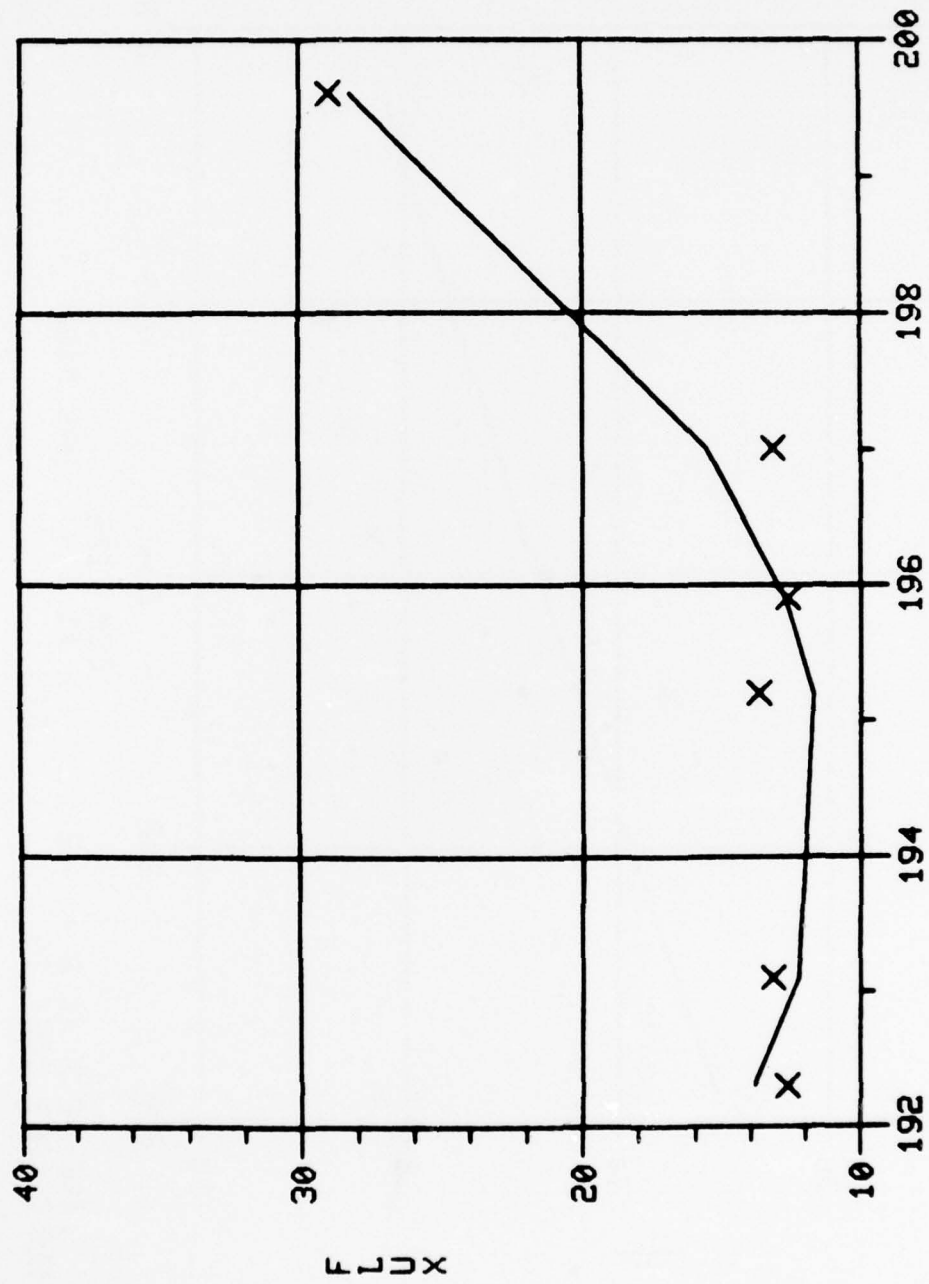

$Y = .61 X^{2} + -.24E+03 X + 23232.6812$
 SQ MULT CORR COEF IS .940

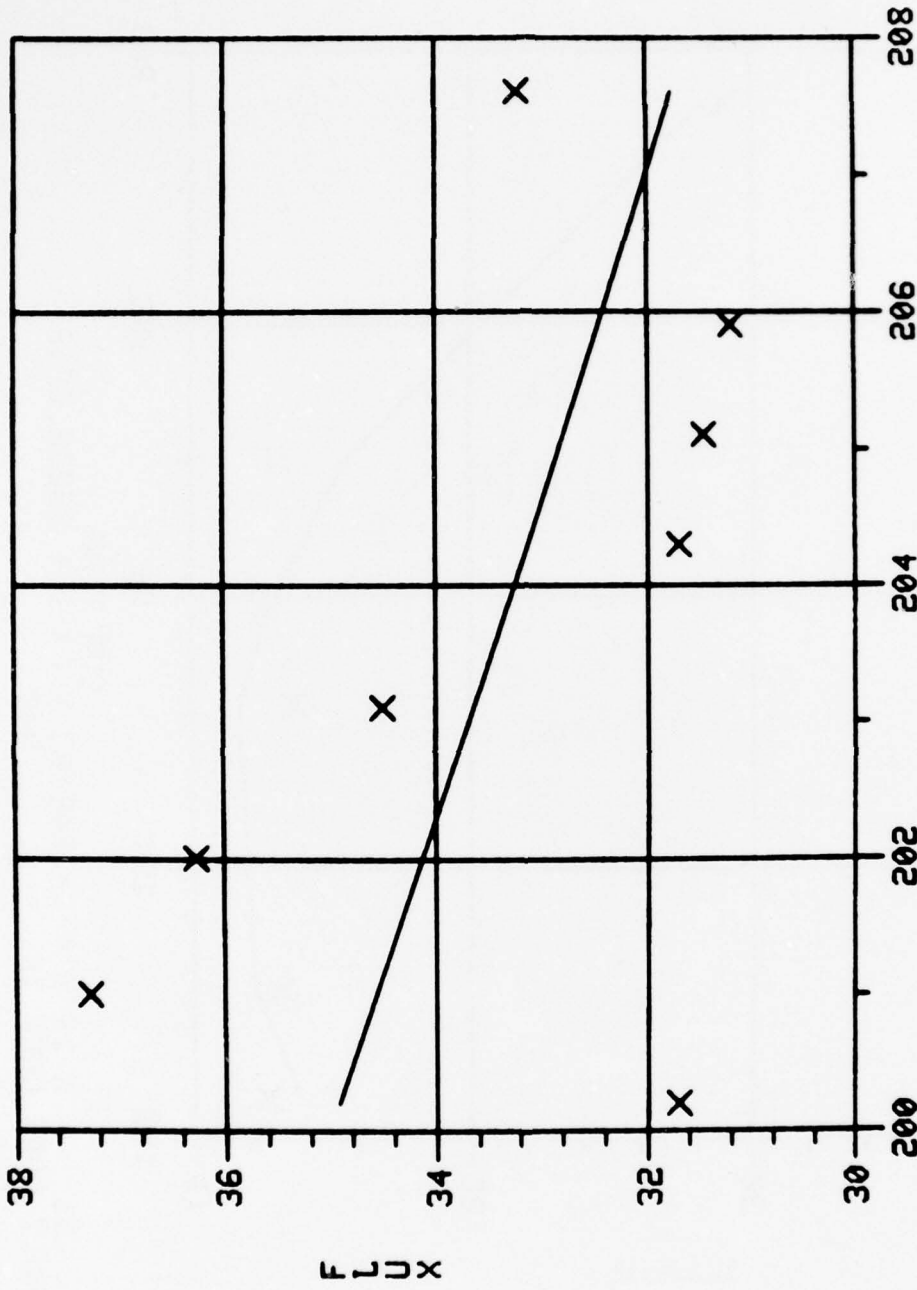

Y = .40E-02 X ** 2 + -2.1 X ** 1 + 285.9156
 SQ MULT CORR COEF IS .213

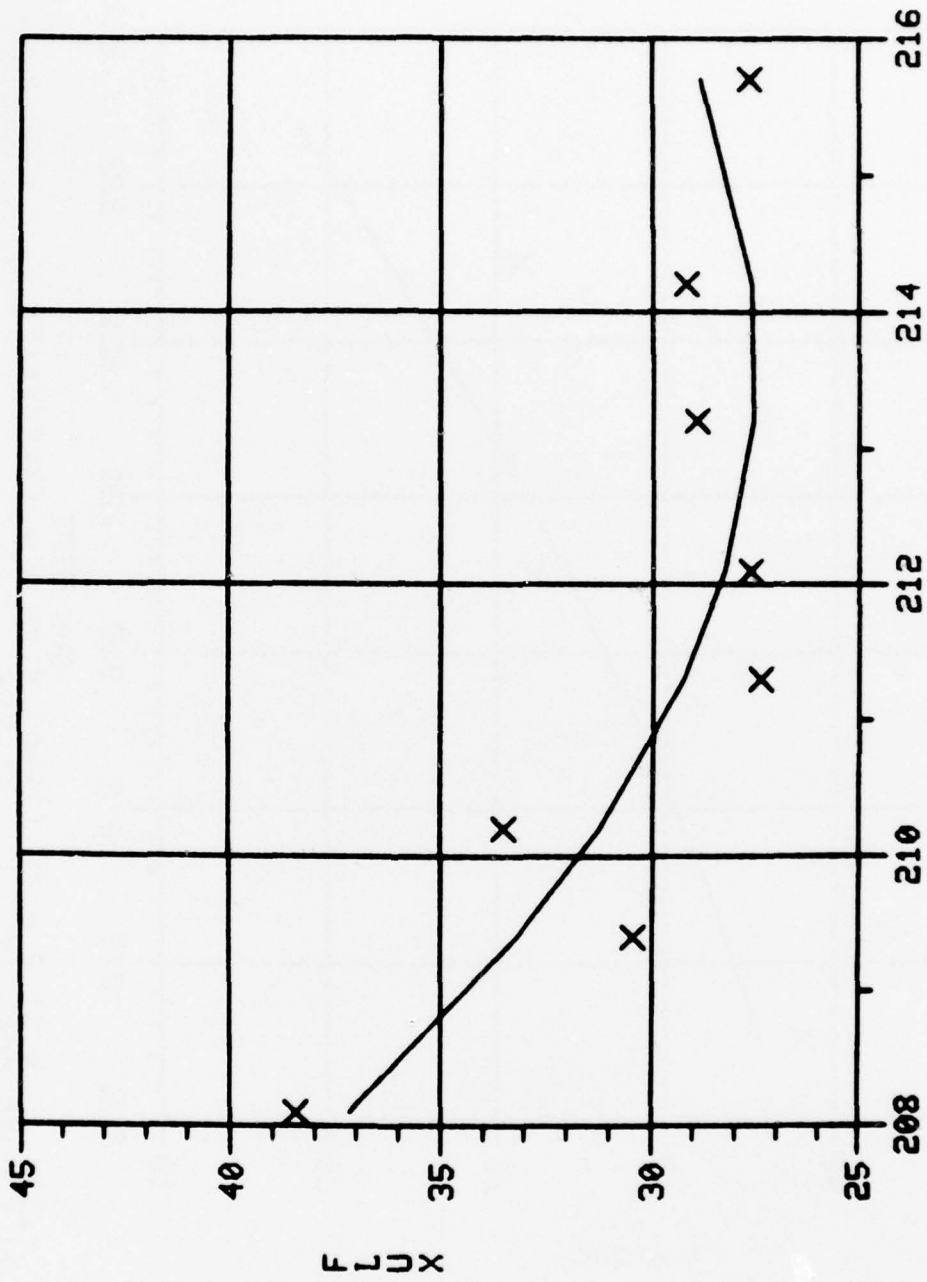

$Y = .31 X^{XX 2} + -.13E+03 X^{XX 1} + 14357.5229$
 SQ MULT CORR COEF IS .769

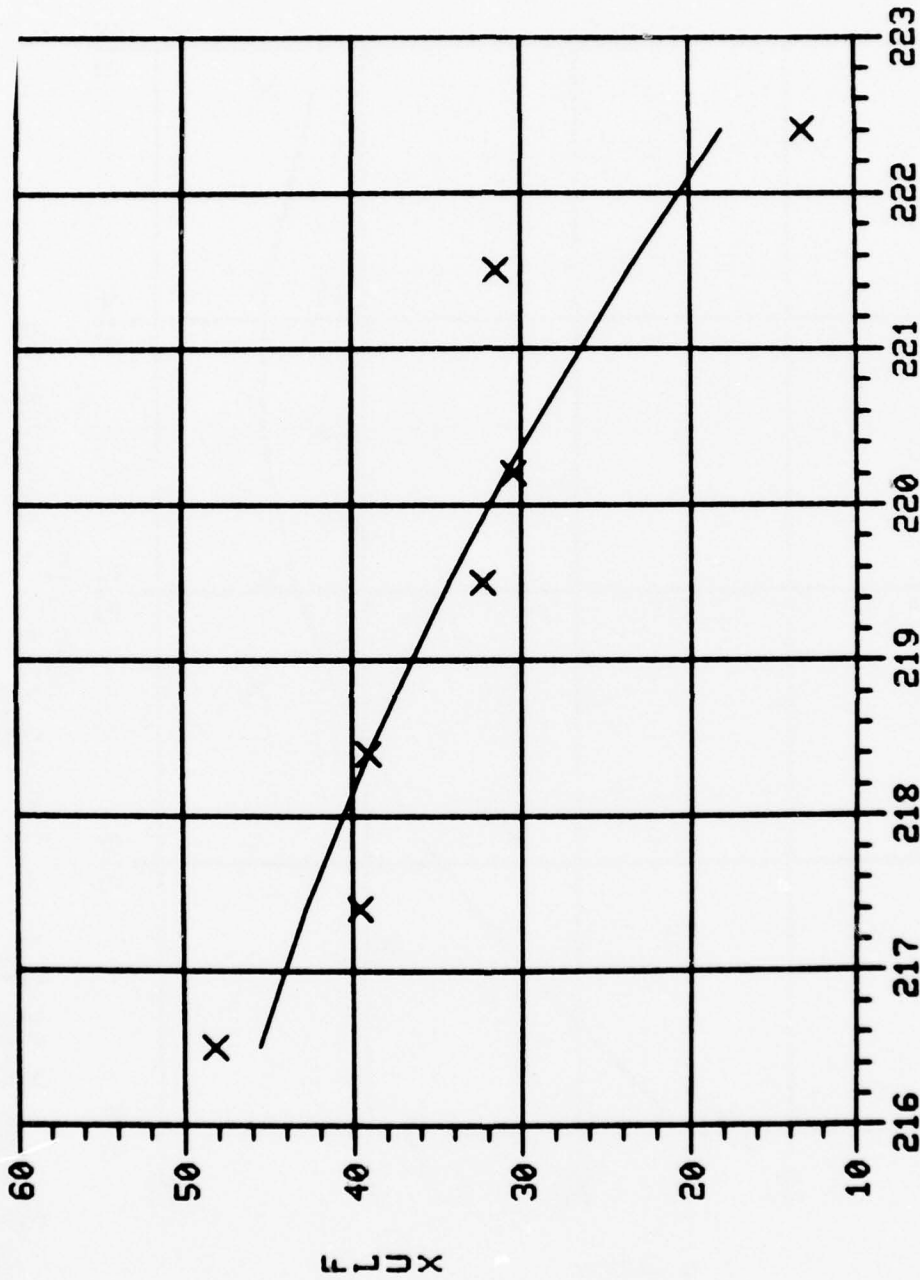

Y = -.31 X ** 2 + .13E+03 X ** 1 + *****
 SQ MULT CORR COEF IS .851

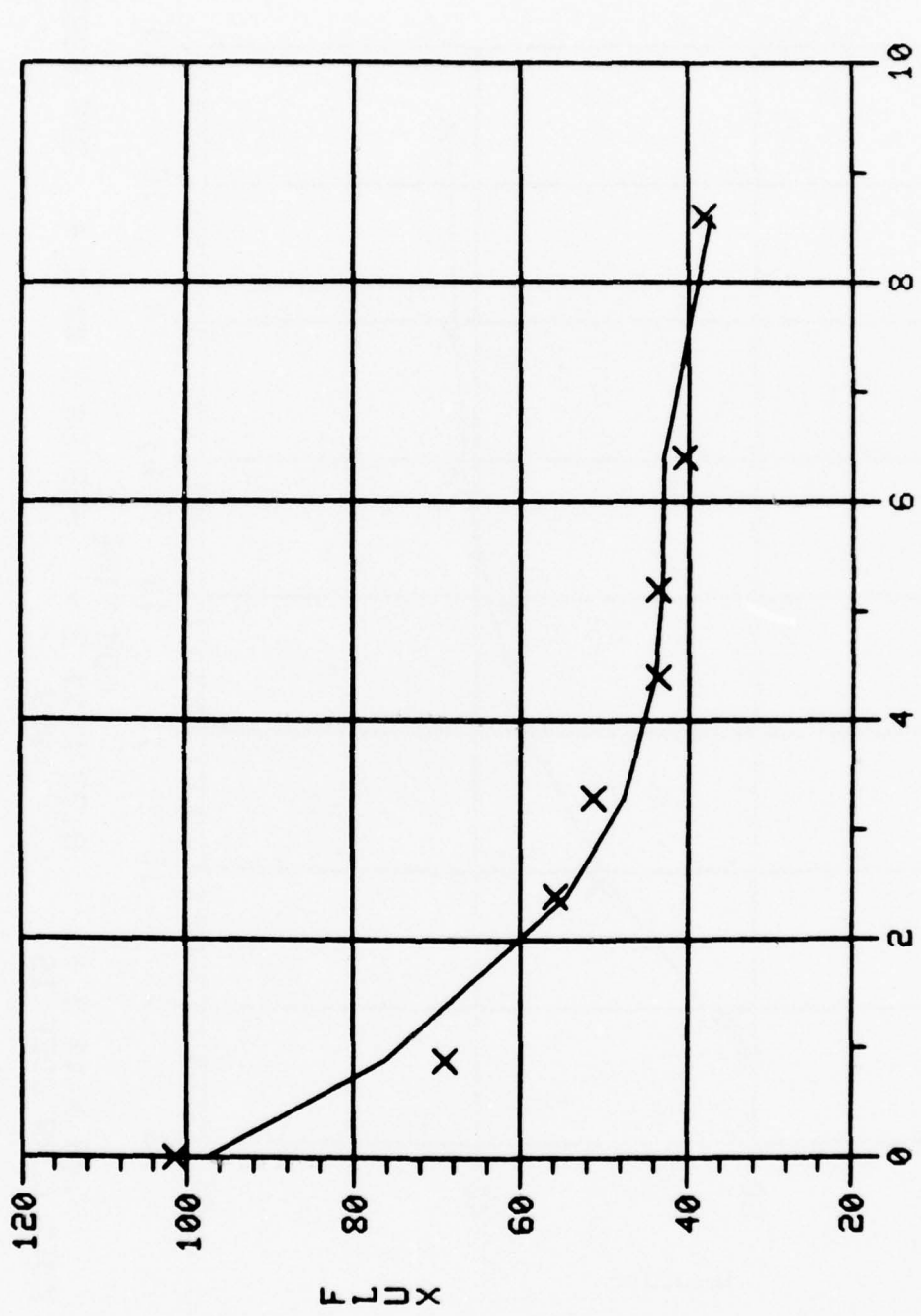

$$Y = -.27 X^{**3} + 4.77 X^{**2} - 27.90 X^{**1} + 97.6145$$
 SO MULT CORR COEF IS .972

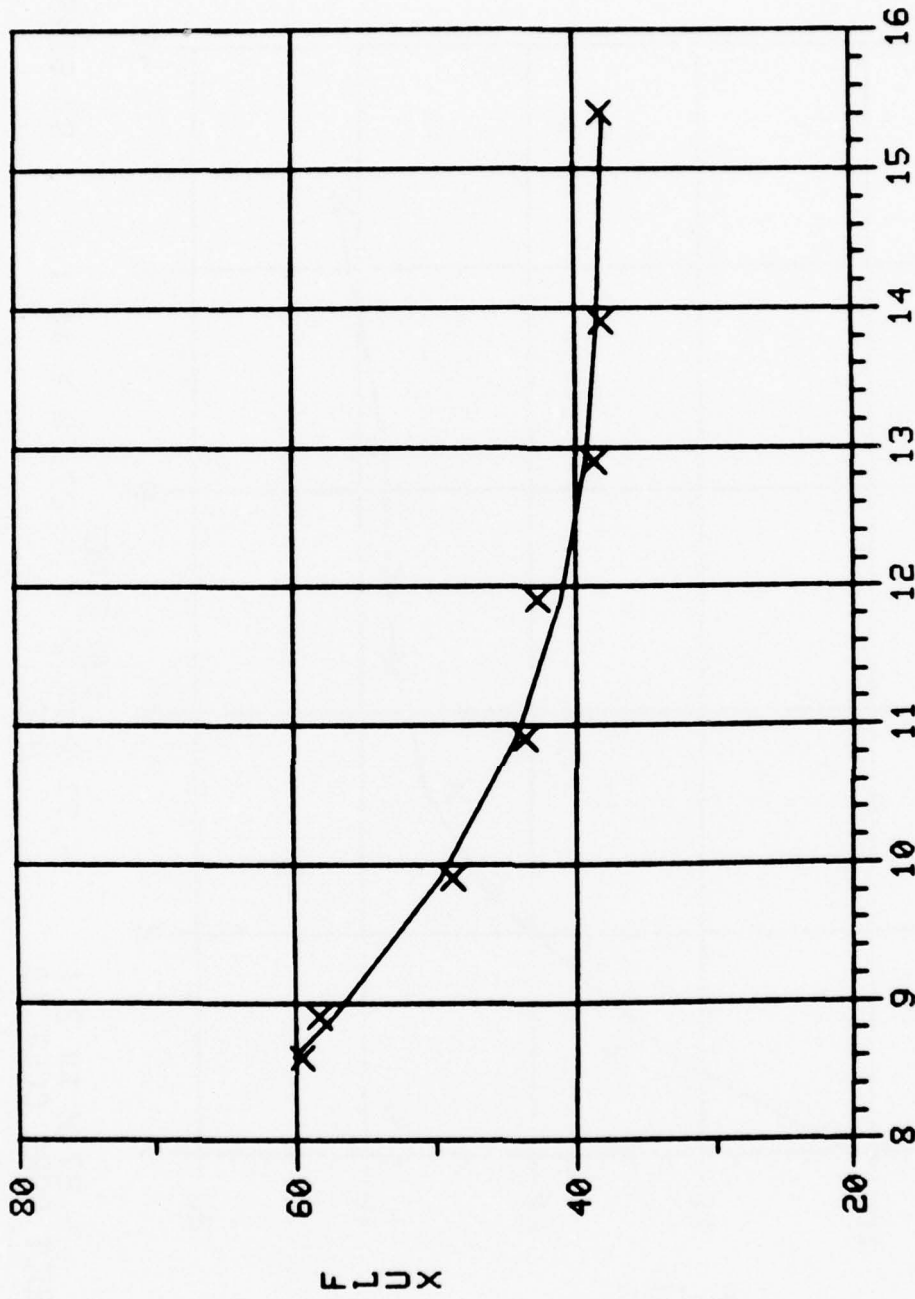

$Y = -.08 X^{**3} + 3.72 X^{**2} - 55.50 X^{**1} + 315.6292$
 SQ MULT CORR COEF IS .989

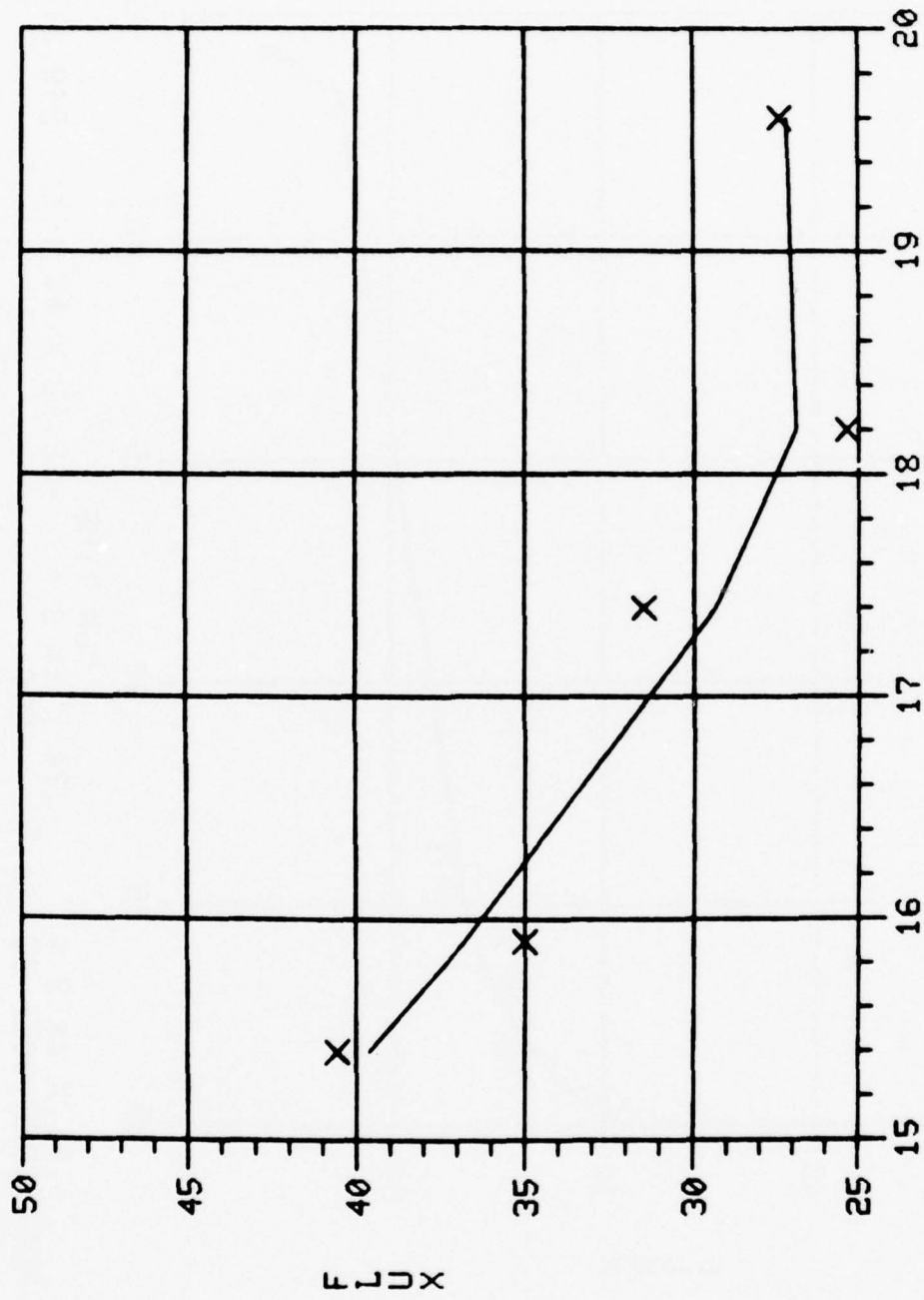

$$Y = .16 X^{**3} + -7.60 X^{**2} + 111.60 X^{**1} + -476.1777$$

SO MULT CORR COEF IS .925

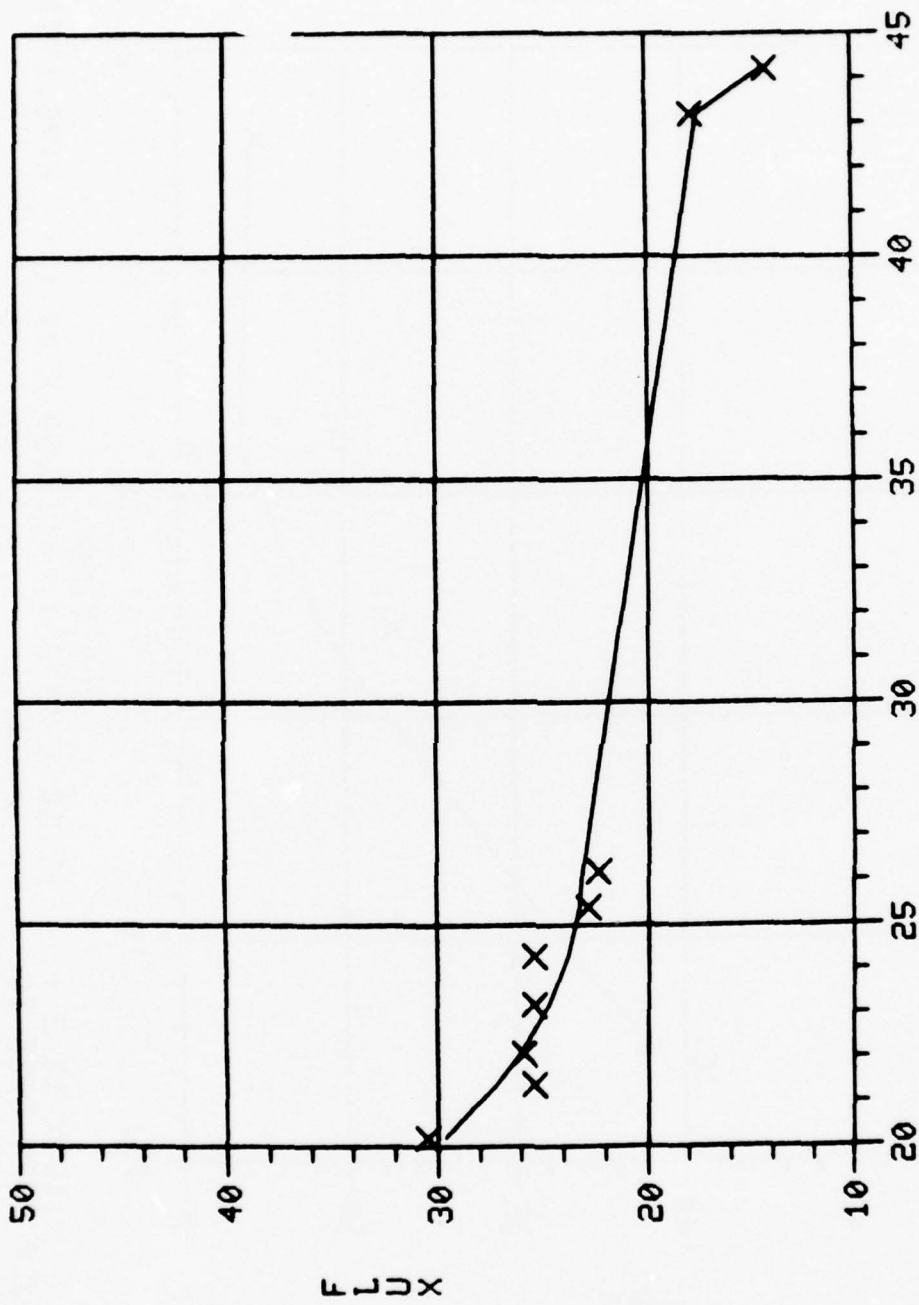

$$Y = -.01 X^{**3} + .74 X^{**2} - 22.62 X^{**1} + 249.6184$$
 SQ MULT CORR COEF IS .958

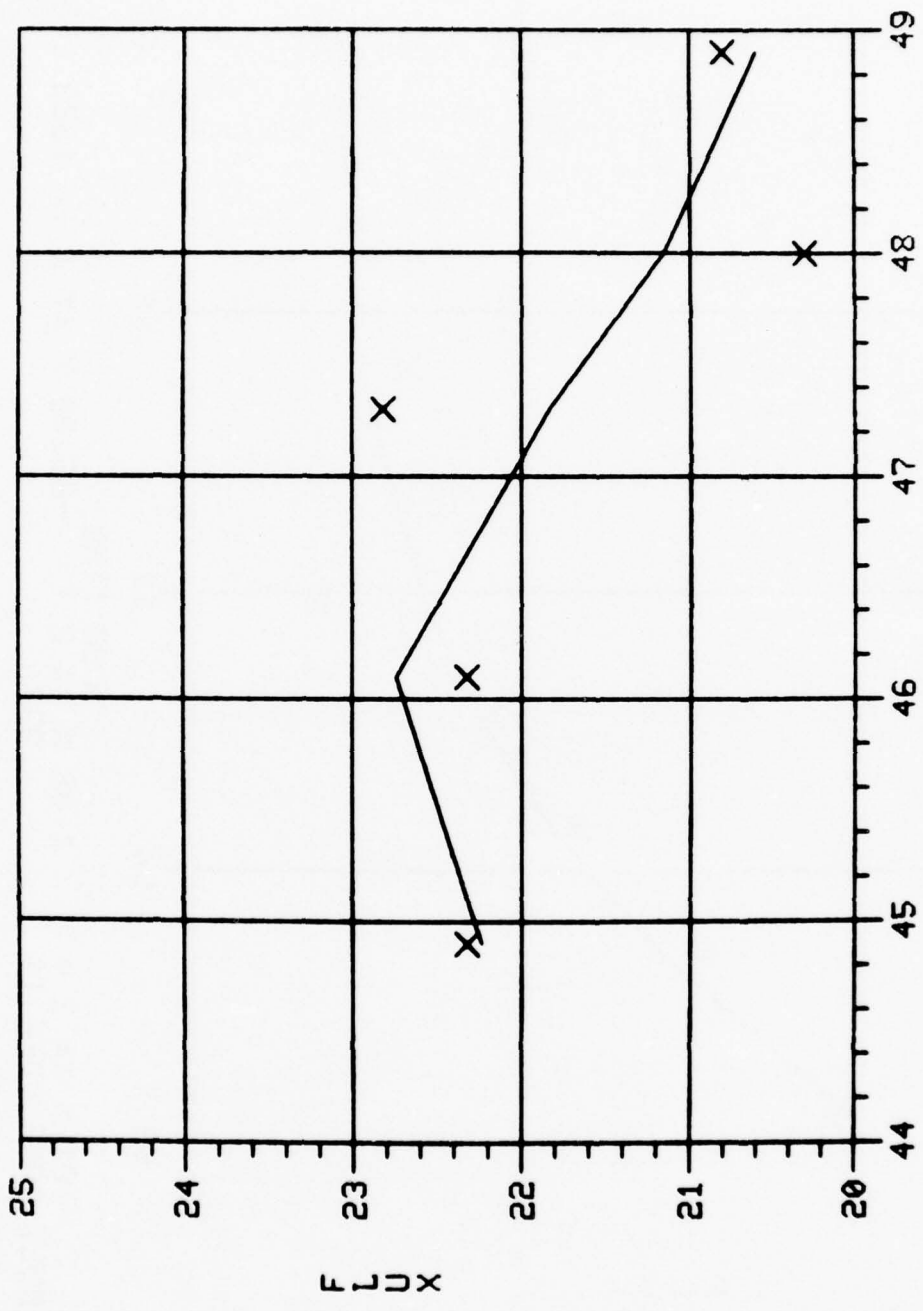

$Y = .12 X^3 + -17.10 X^2 + 810.56 X + 1 + *****$
 SO MULT CORR COEF IS .599

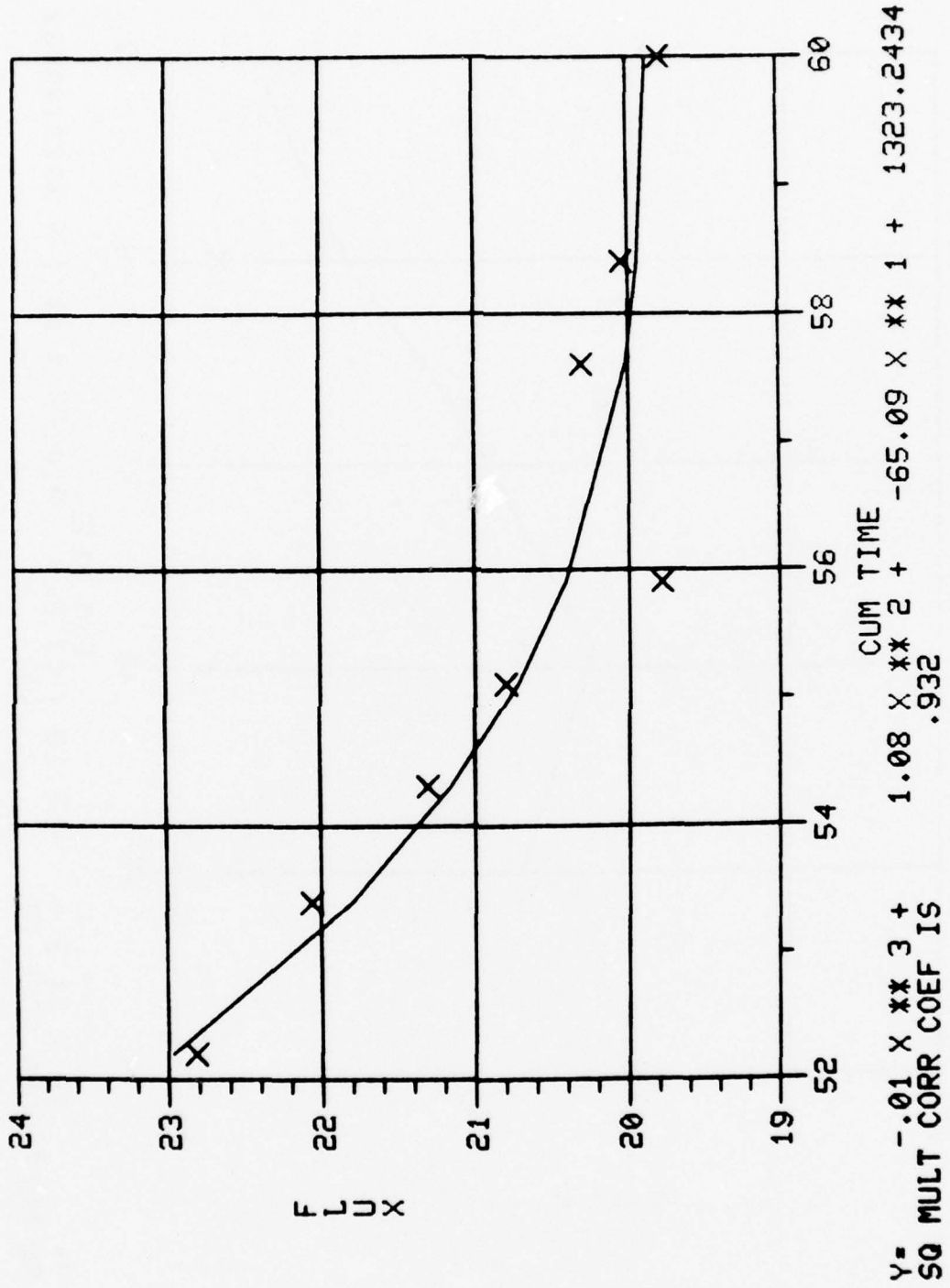

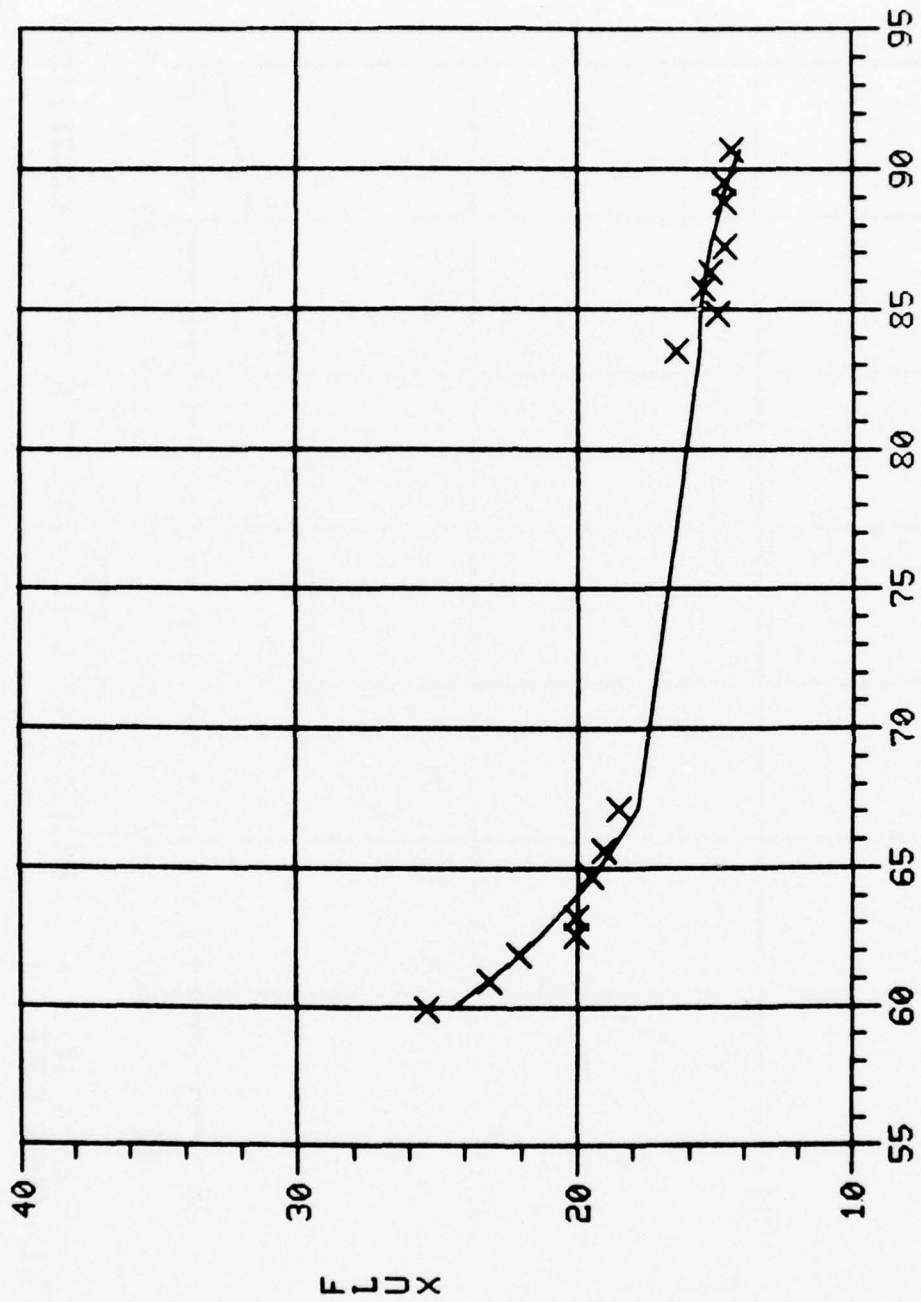

$$Y = -.00 X^{**3} + .28 X^{**2} + -.22.48 X^{**1} + 610.8367$$

$$SQ \text{ MULT CORR COEF IS } .973$$

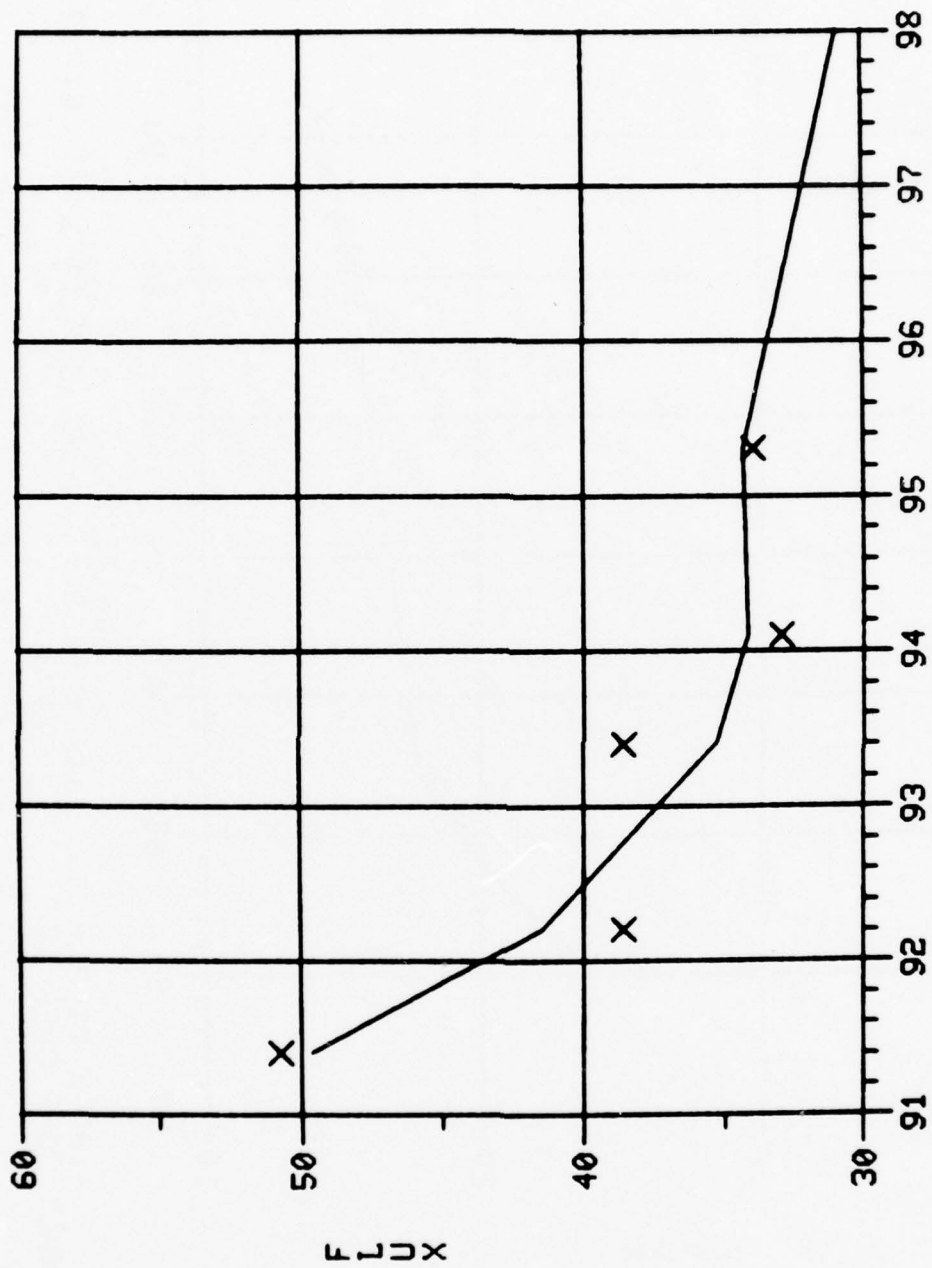

$Y = -.28 X^{**3} + 80.83 X^{**2} + -7708.17 X^{**1} + \text{XXXXXXXXXXXX}$
 SQ MULT CORR COEF IS .915

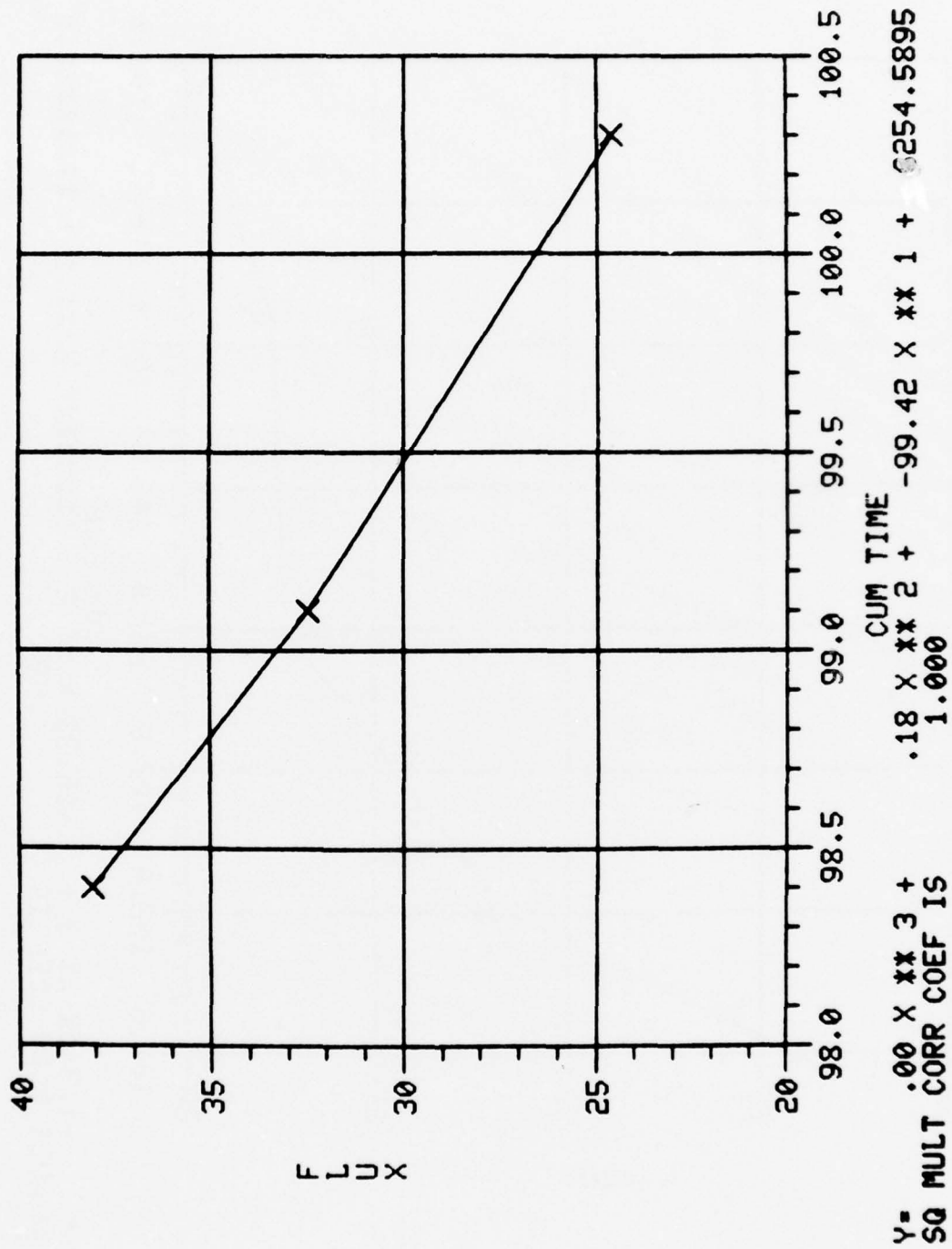

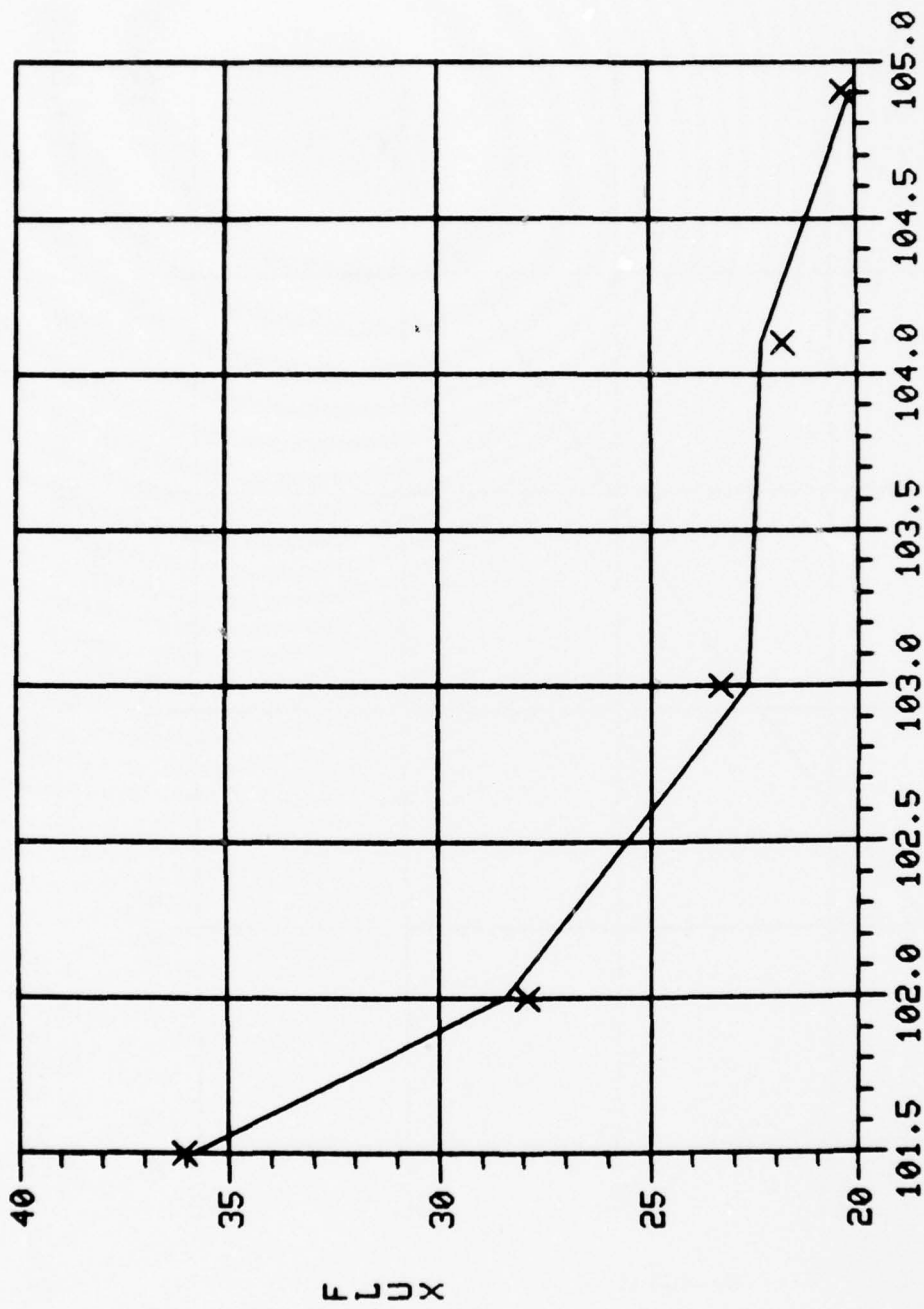

Y= -1.34 X XX 3 + 415.33 X XX 2 + XXXXXXXXXXXX X XX 1 + XXXXXXXXXXXXX
 SQ MULT CORR COEF IS .994

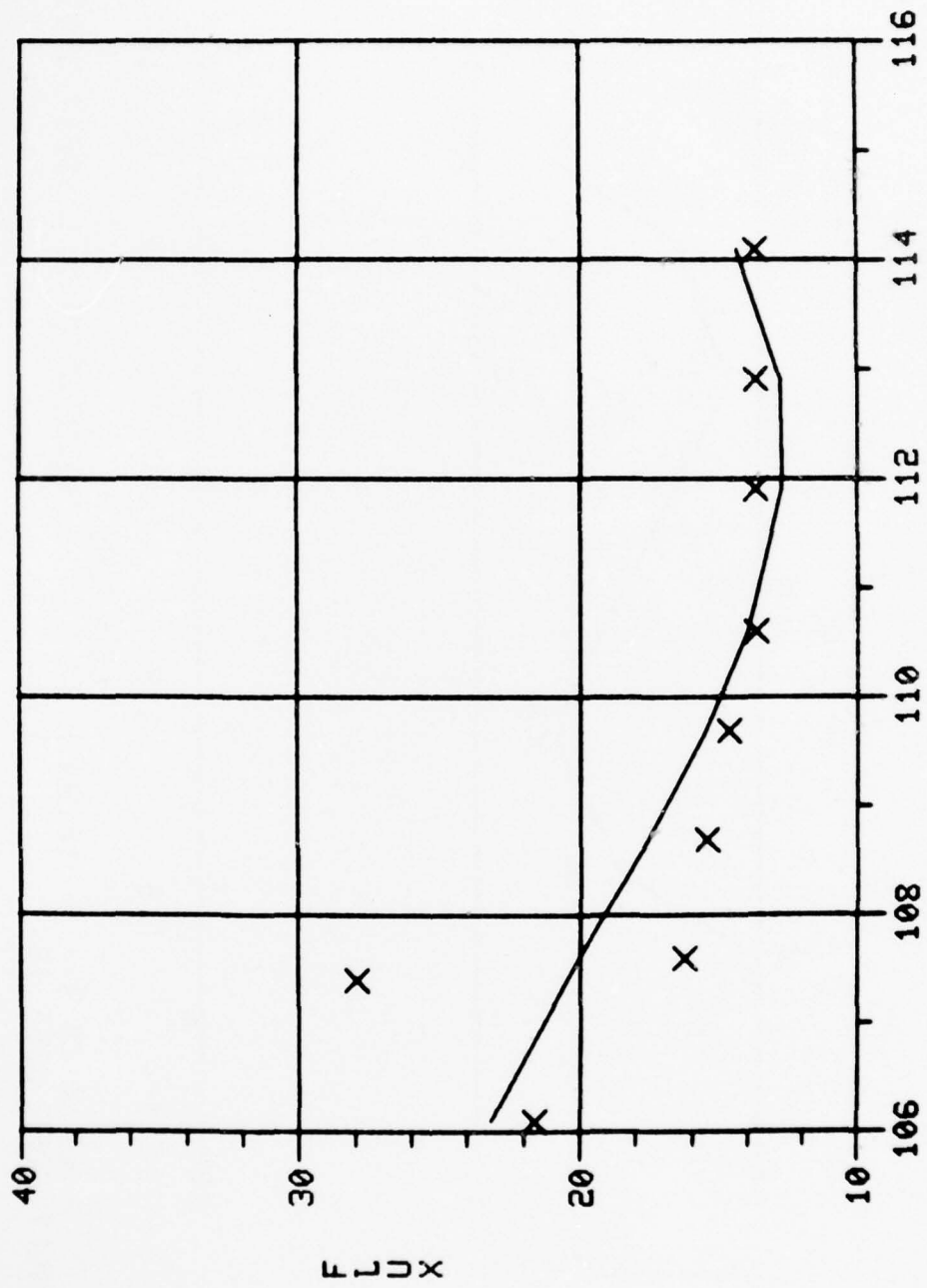

Y = .04 X XX 3 + -11.94 X XX 2 + 1285.65 X XX 1 + XXXXXXXXXXXXX
 SQ MULT CORR COEF IS .584

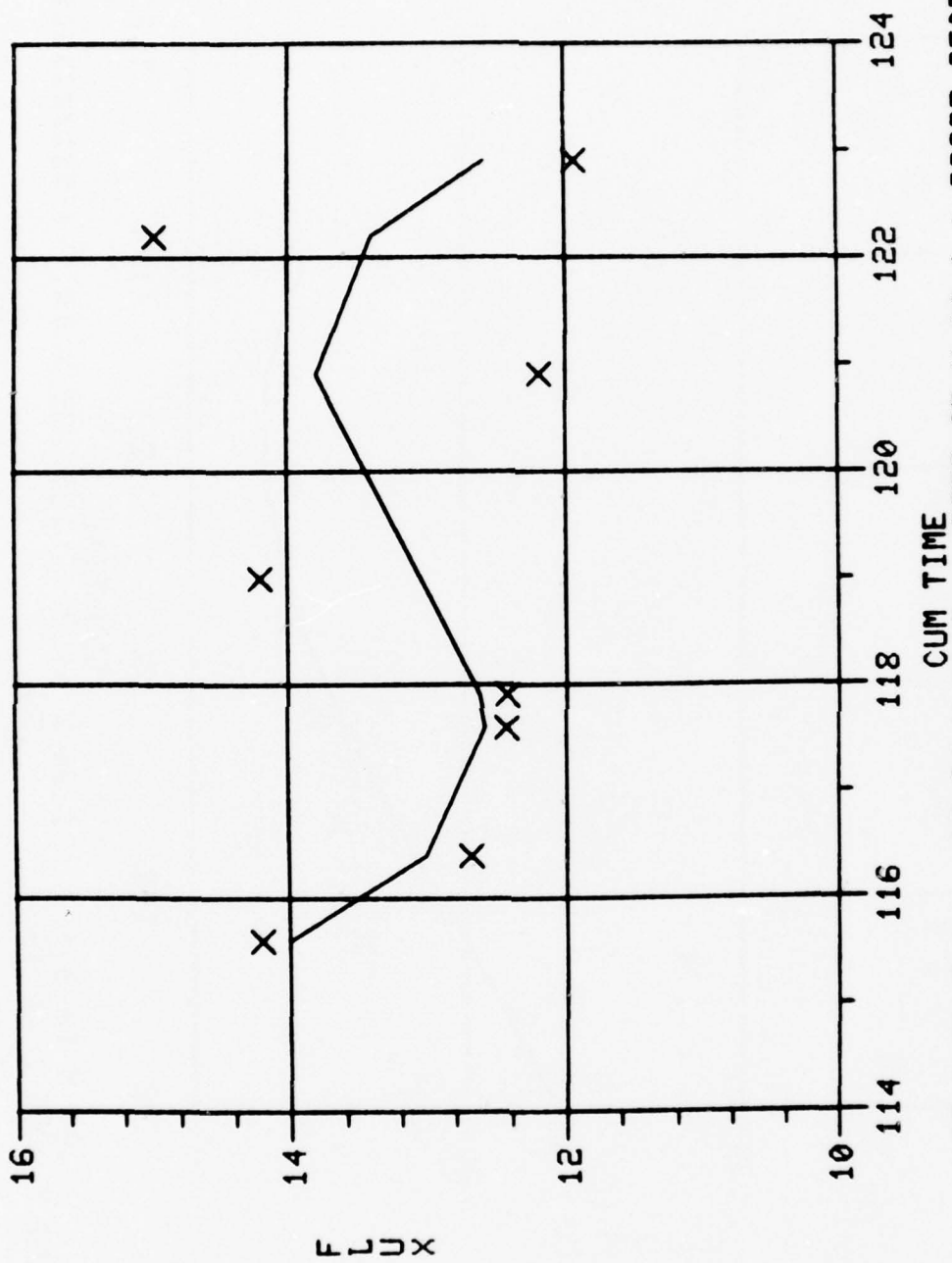

$$Y = -.05 X^{**3} + 18.94 X^{**2} - 2259.65 X^{**1} + 89837.3507$$
 SQ MULT CORR COEF IS .234

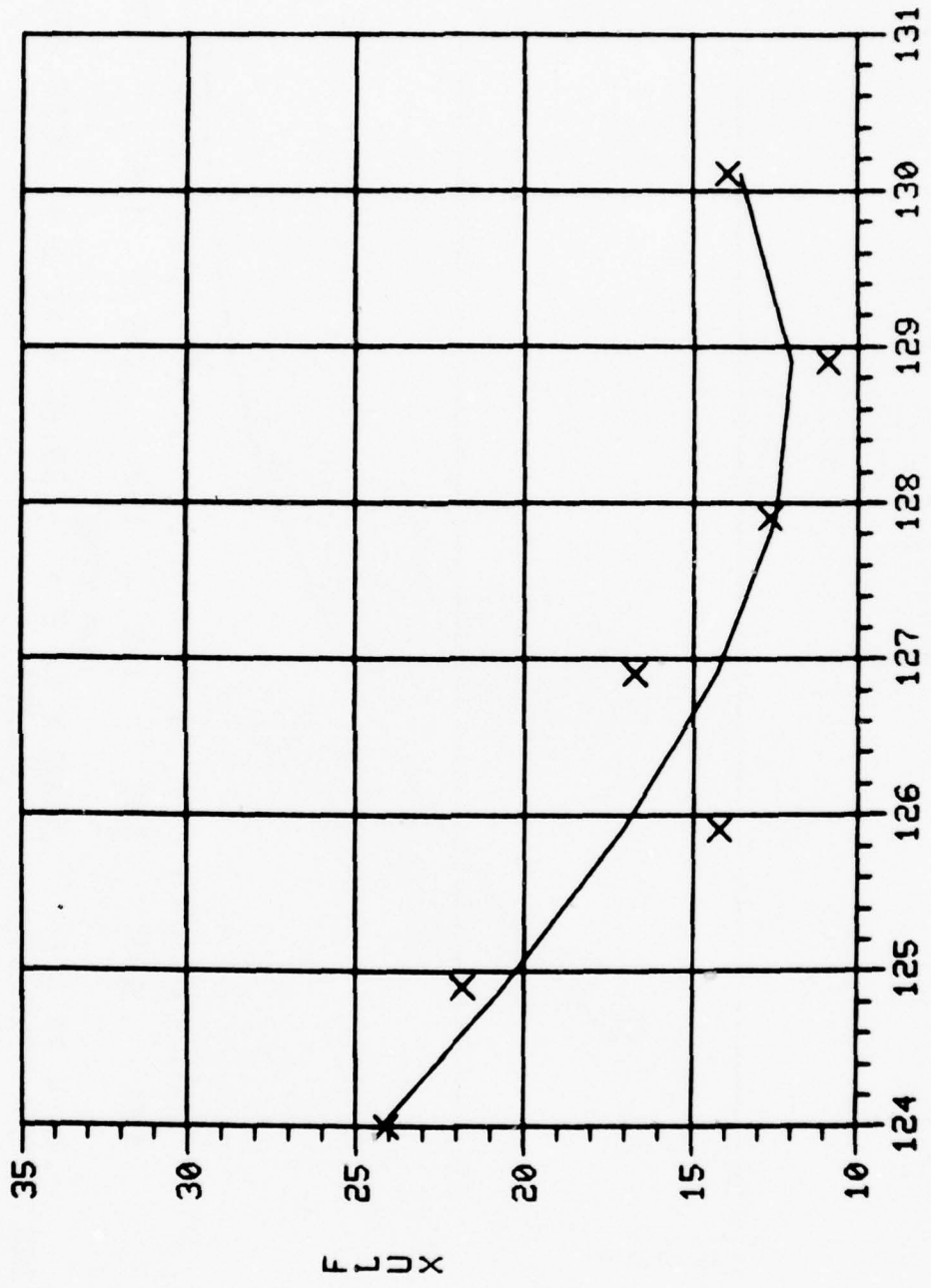

Y = .05 X ** 3 + -16.98 X ** 2 + 2087.94 X ** 1 + *****
 SQ MULT CORR COEF IS .880

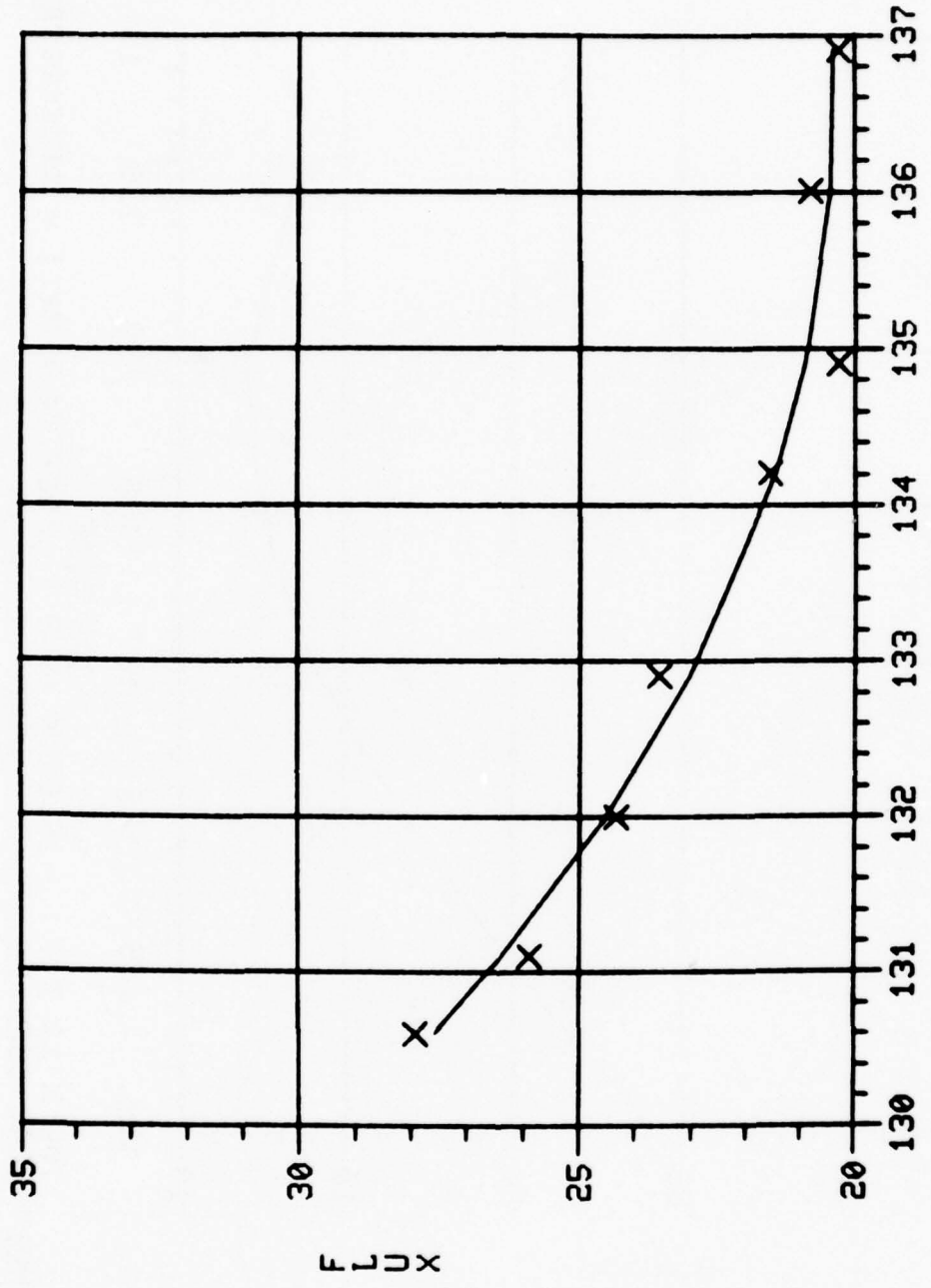

Y= -.00 X ** 3 + 1.22 X ** 2 + -192.06 X ** 1 + 9916.2396
 SQ MULT CORR COEF IS .978

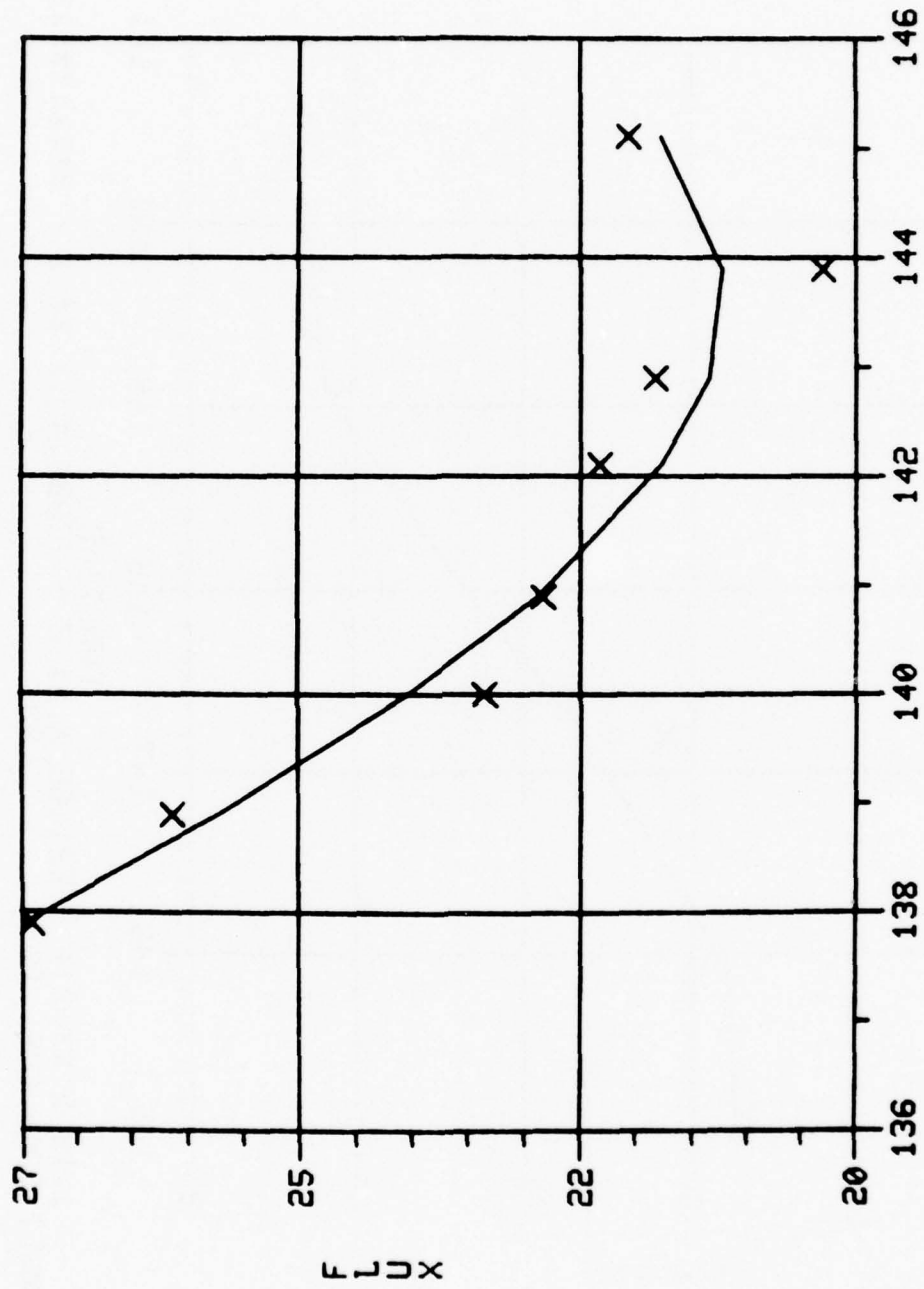

Y = .01 X XX 3 + -4.23 X XX 2 + 571.50 X XX 1 + XXXXXXXXXXXXX
 SQ MULT CORR COEF IS .945

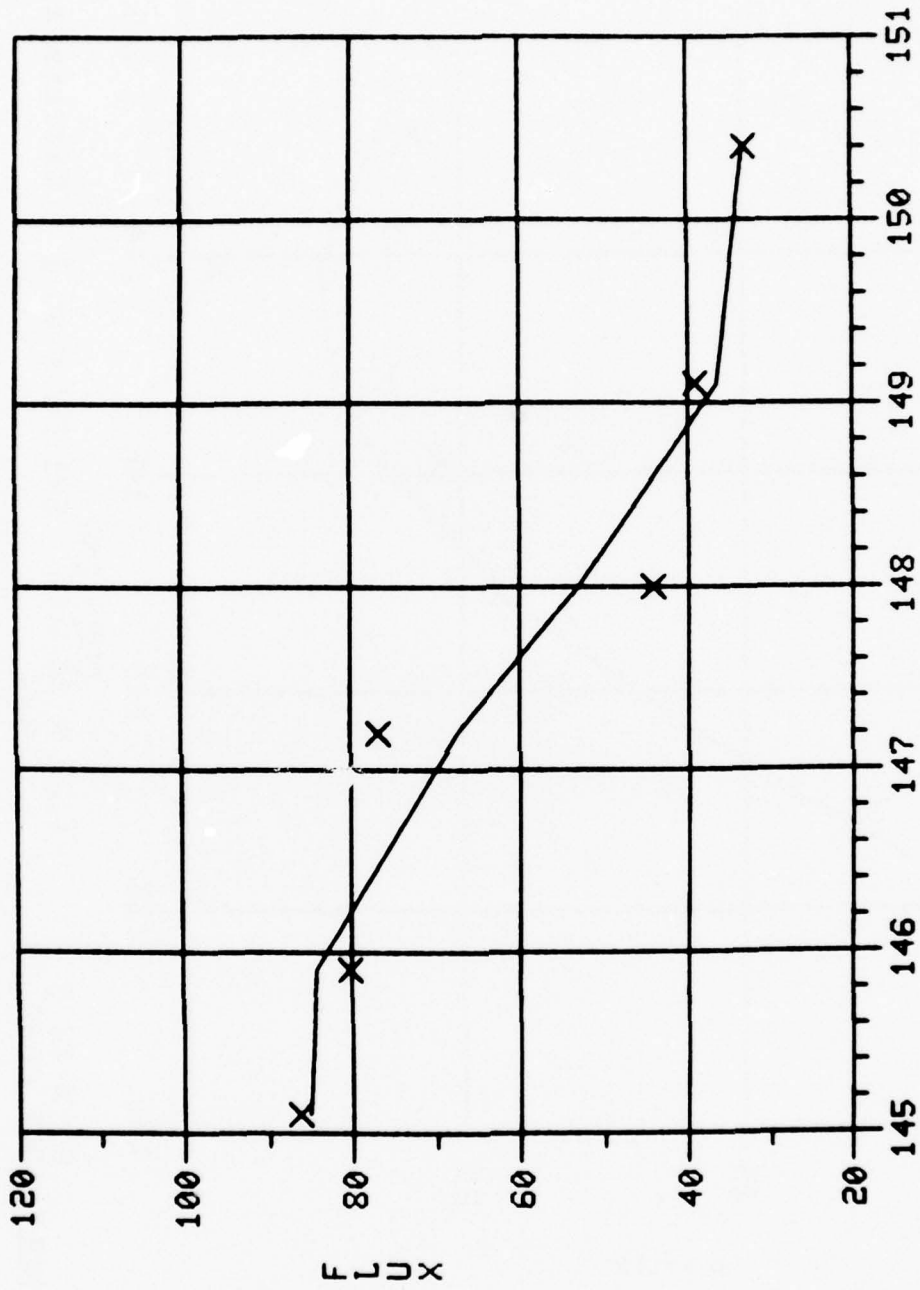

Y= 1.18 X XX 3 + -521.65 X XX 2 + 77022.49 X XX 1 + *****
 SQ MULT CORR COEF IS .931

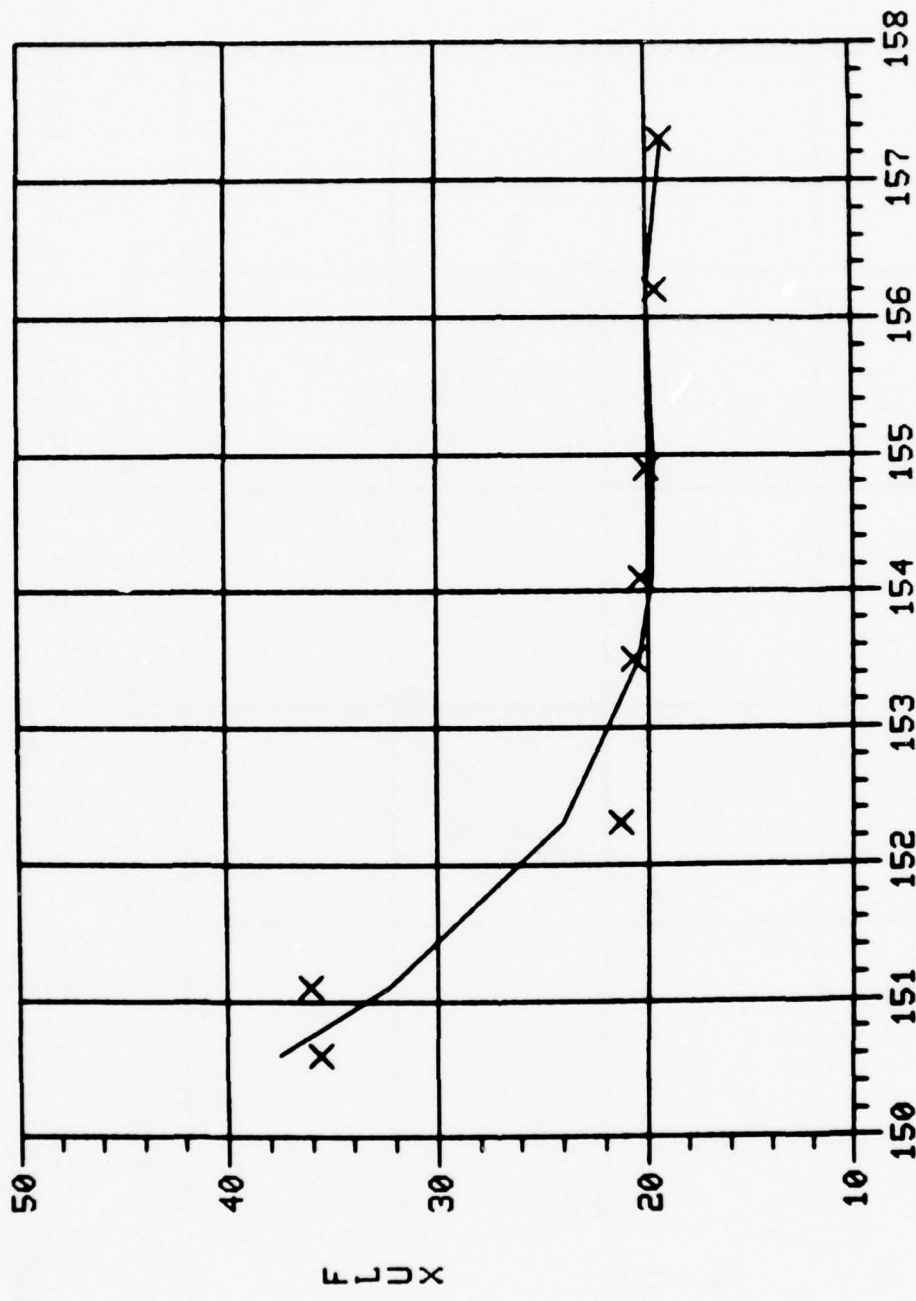

Y = -.17 X XX 3 + 81.16 X XX 2 + XXXXXXXXXXXX X XX 1 + XXXXXXXXXXXXXXX
 SQ MULT CORR COEF IS .929

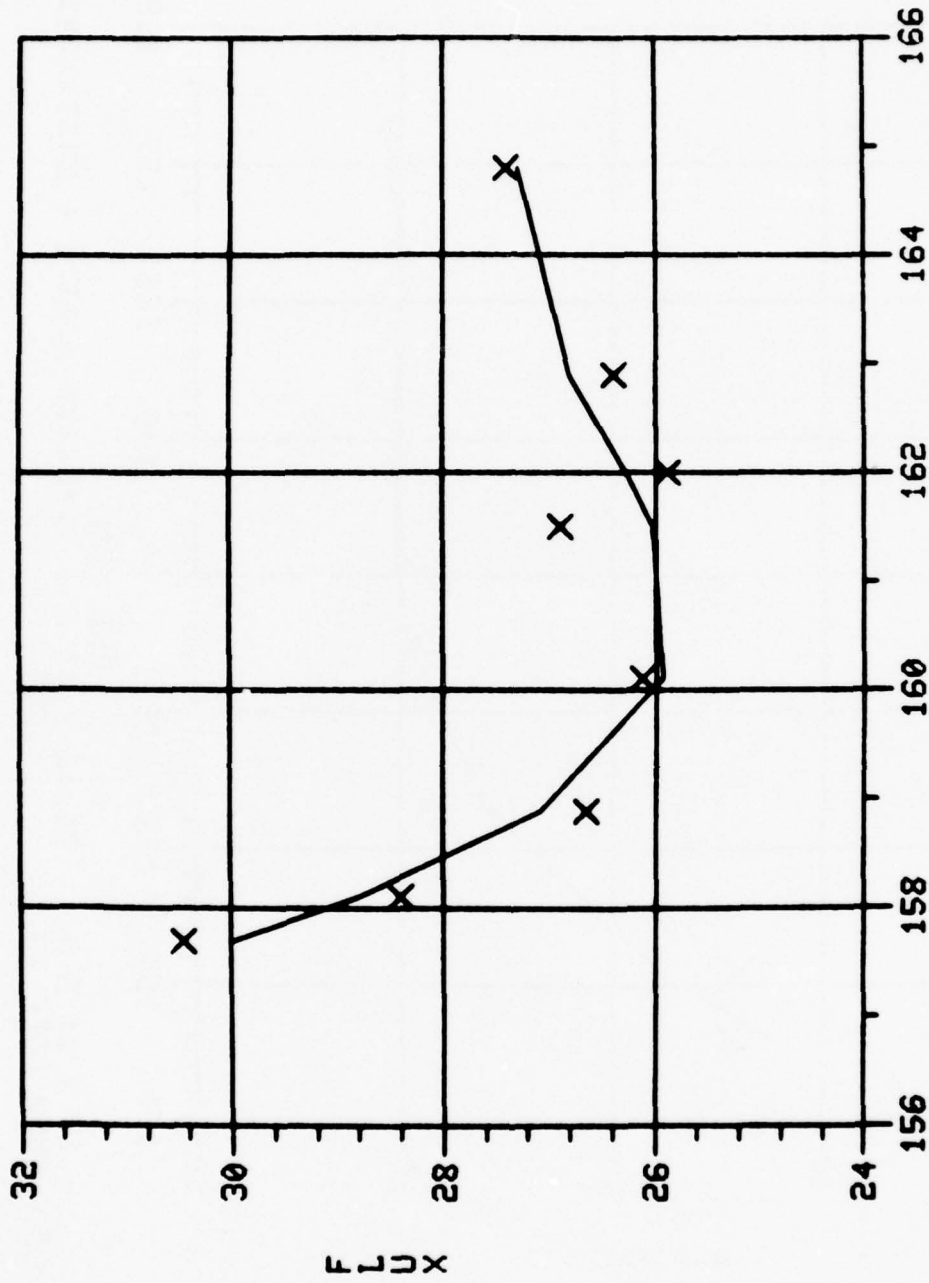

Y = $-.56E-01 X^{XX 3} + 27. X^{XX 2} + -.45E+04 X^{XX 1} + XXXXXXXXXXXXX$
 SQ MULT CORR COEF IS .896

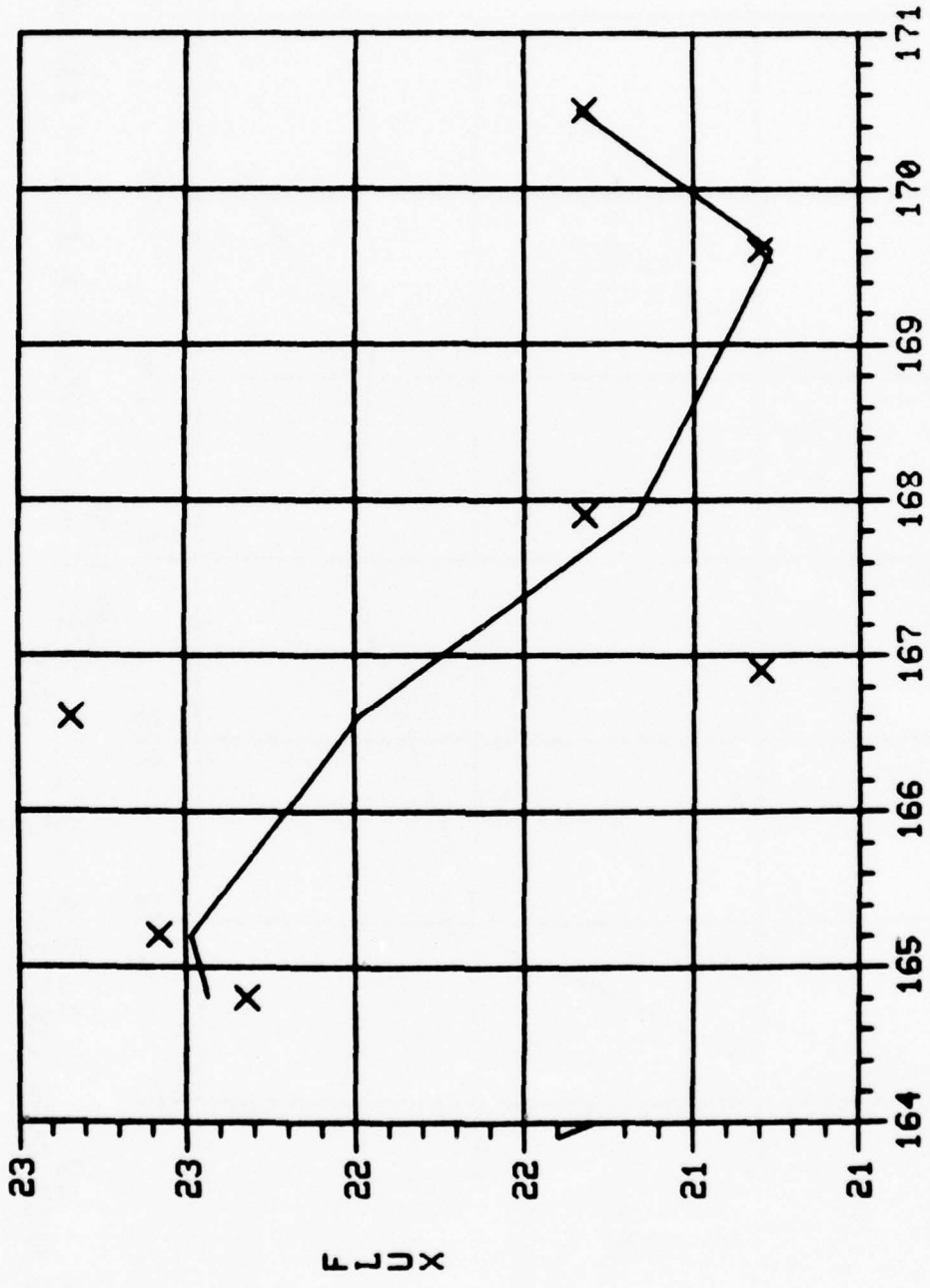

Y= .53E-01 X XX 3 + -27. .593
 SQ MULT CORR COEF IS
 CUM TIME X XX 2 + .44E+04 X XX 1 + XXXXXXXXXXXXX

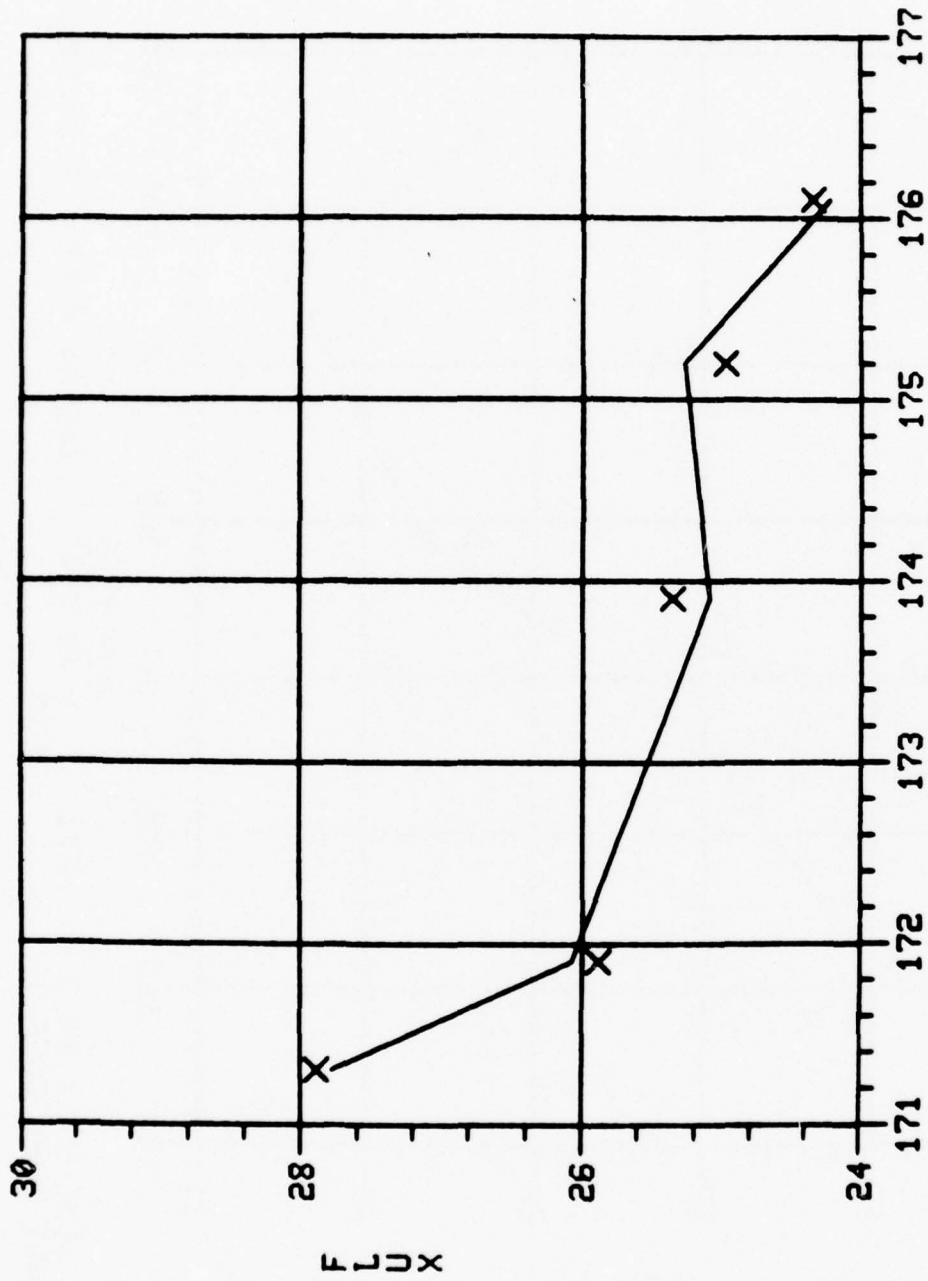

Y = -.19 X XX 3 + 97. X XX 2 + -.17E+05 X XX 1 + XXXXXXXXXXXXX
 SQ MULT CORR COEF IS .971

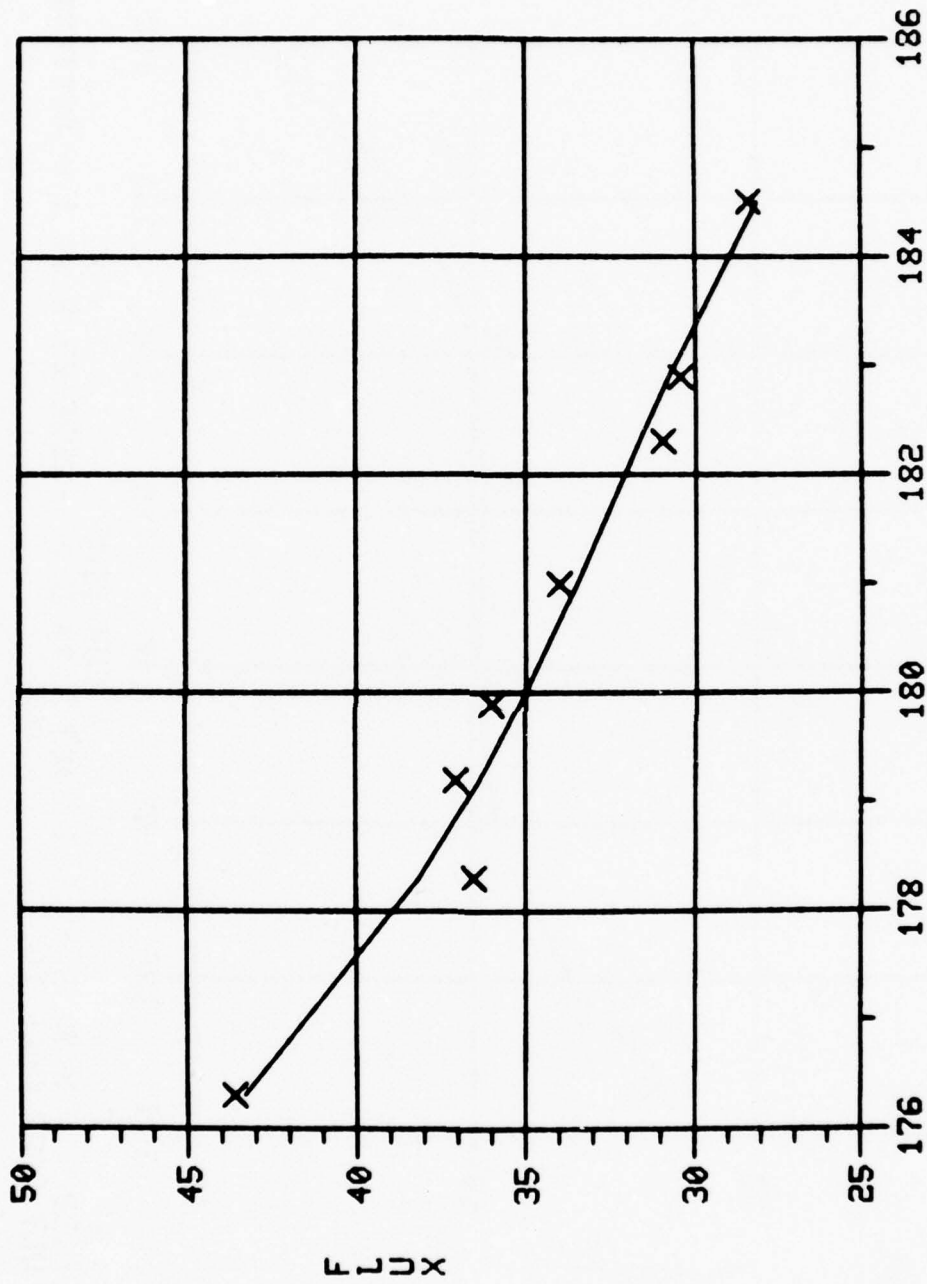

Y = $-.19E-01 X^{XX} 3 + 10. X^{XX} 2 + -.19E+04 X^{XX} 1 + XXXXXXXXXXXXX$
 SQ MULT CORR COEF IS .971

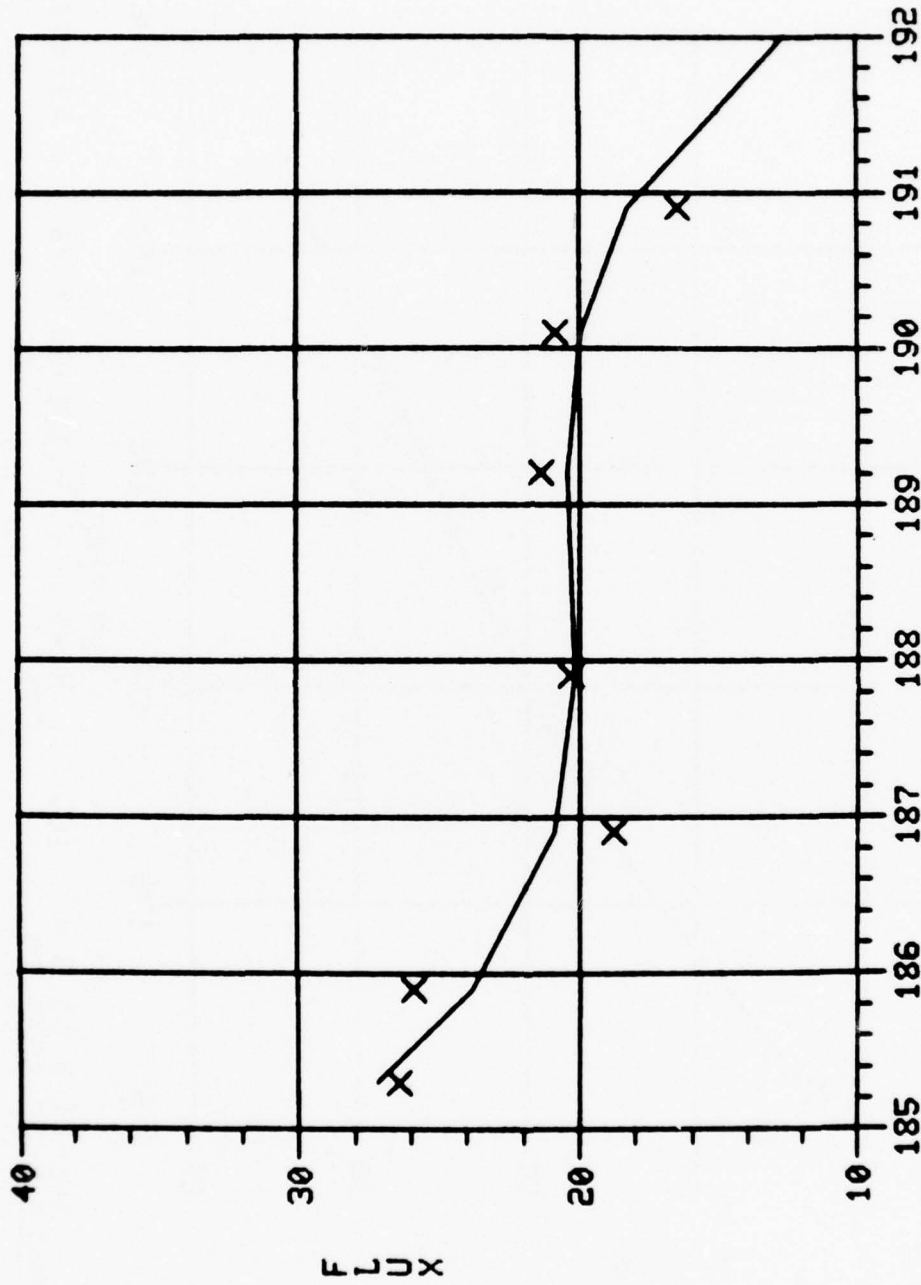

Y = -.22 X XX 3 + .12E+03 X XX 2 + -.23E+05 X XX 1 + XXXXXXXXXXXXX
 SQ MULT CORR COEF IS .895

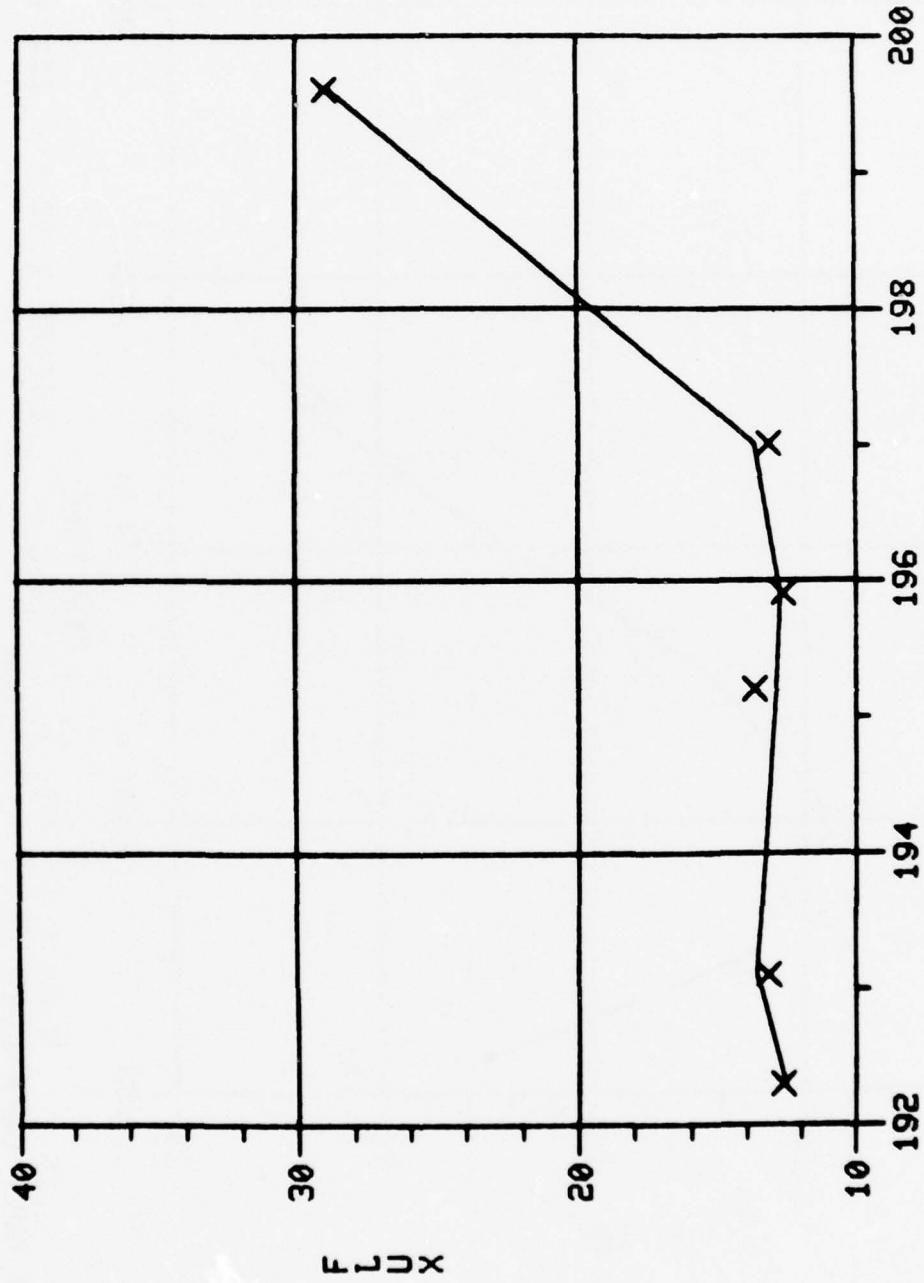

Y = .16 X XX 3 + -92.
 SQ MULT CORR COEF IS .995
 CUM TIME X XX 2 + .18E+05 X XX 1 + *****

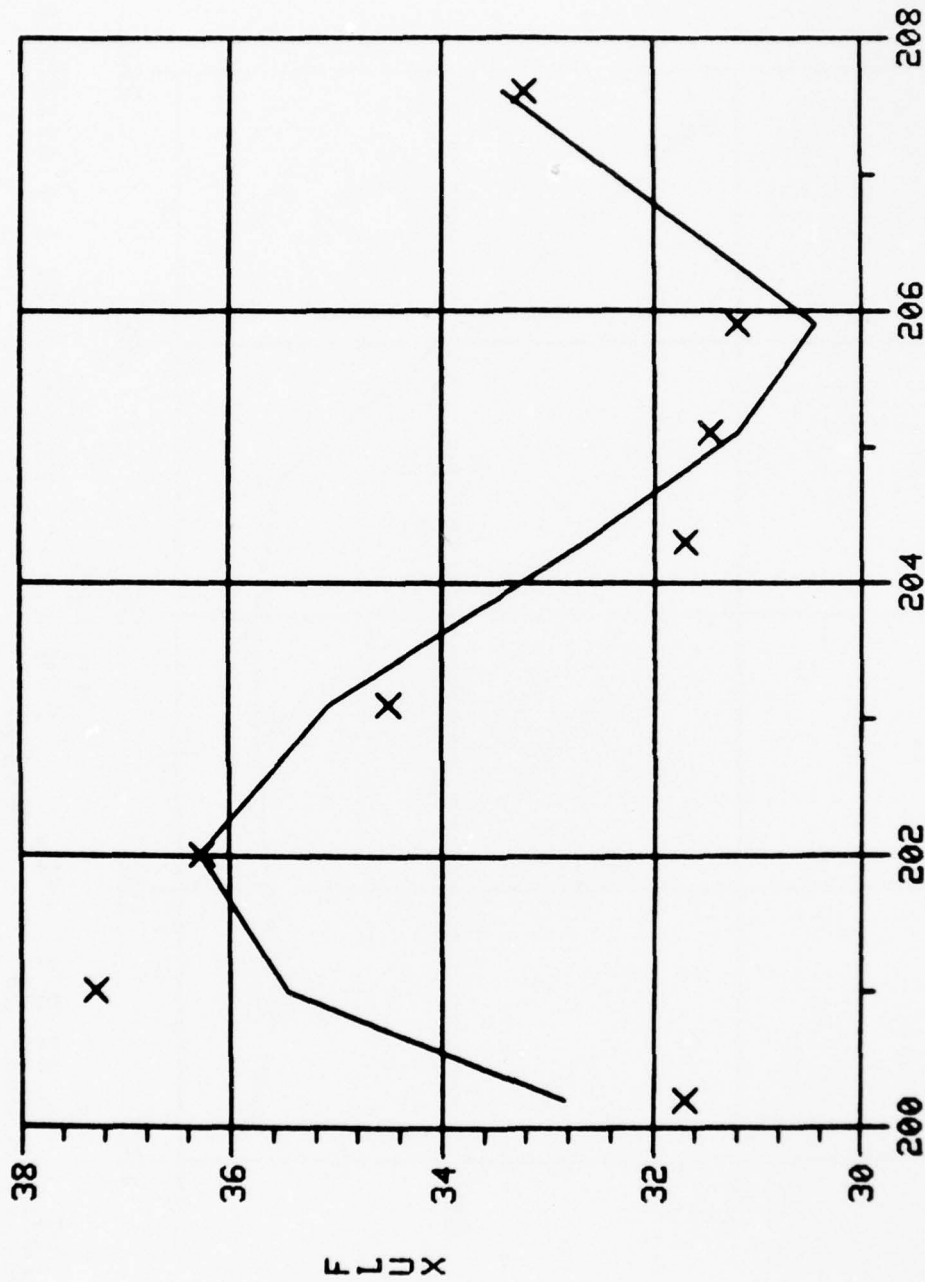

Y = .16 X ** 3 + -97. X ** 2 + .20E+05 X ** 1 + *****
 SQ MULT CORR COEF IS .834

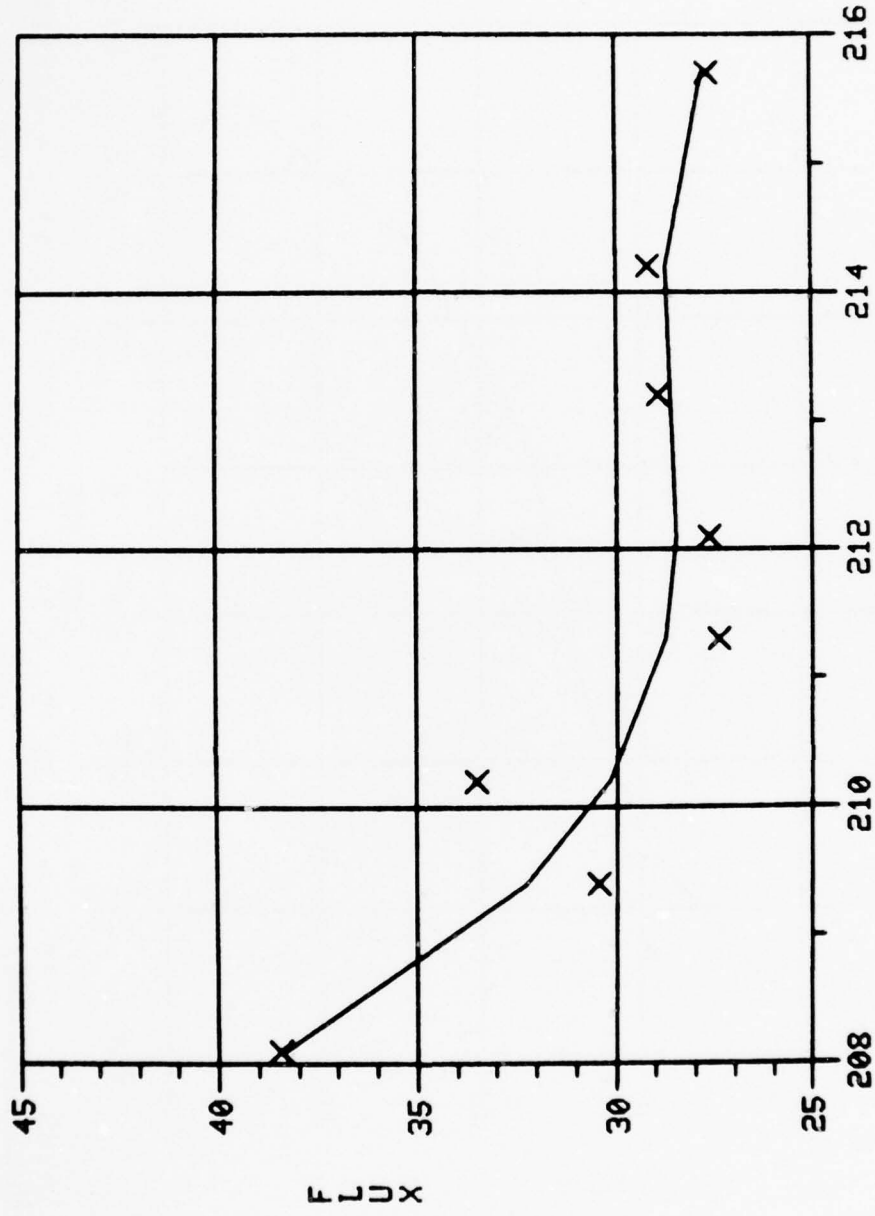

Y = $-.83E-01 X^{**3} + 53. X^{**2} + -.11E+05 X^{**1} + \text{XXXXXXXXXXXX}$
 SQ MULT CORR COEF IS .831

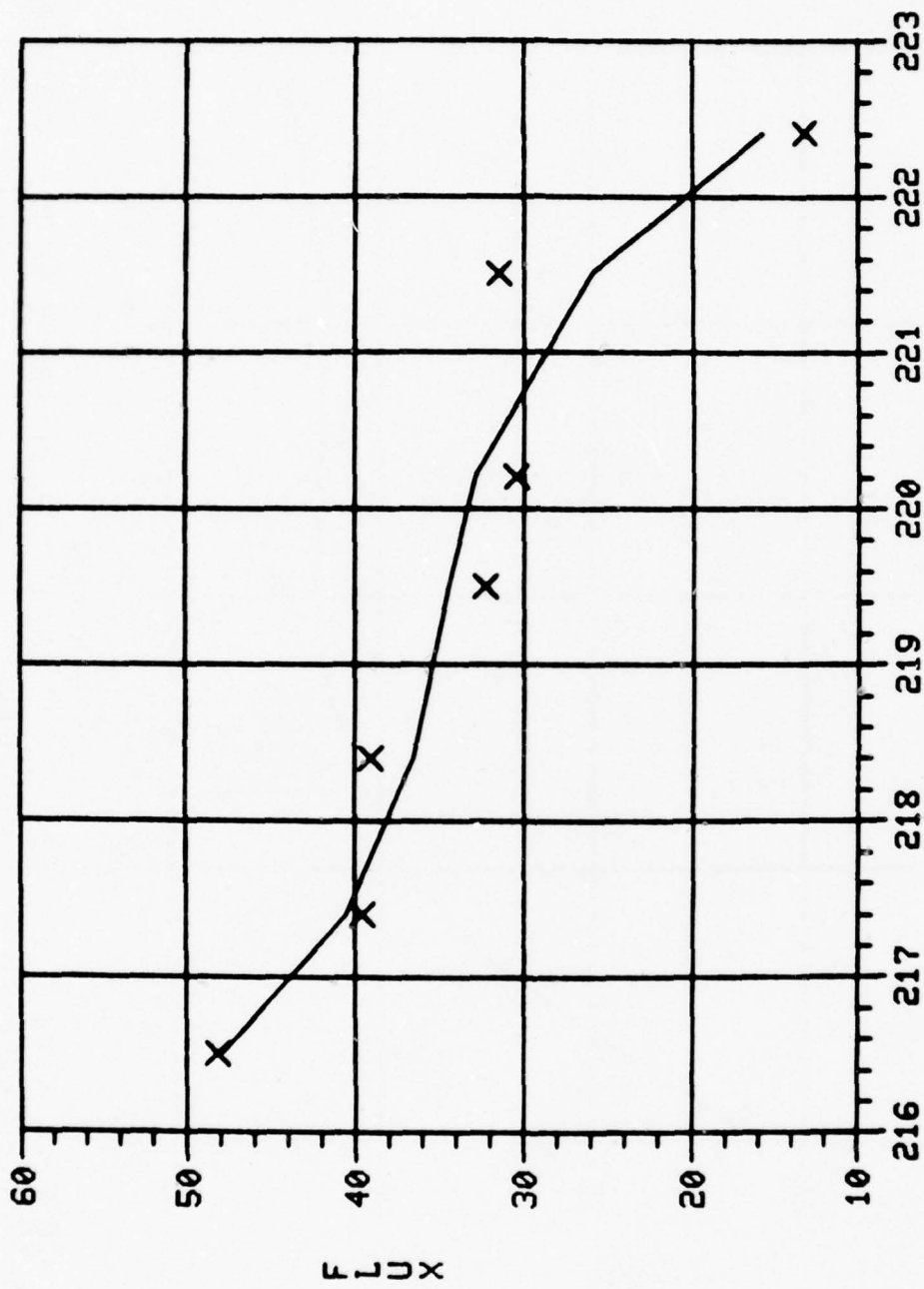

$$Y = -.43 X^{**3} + .28E+03 X^{**2} + -.62E+05 X^{**1} + XXXXXXXXXXXXX$$

$$SQ \text{ MULT CORR COEF IS } .923$$

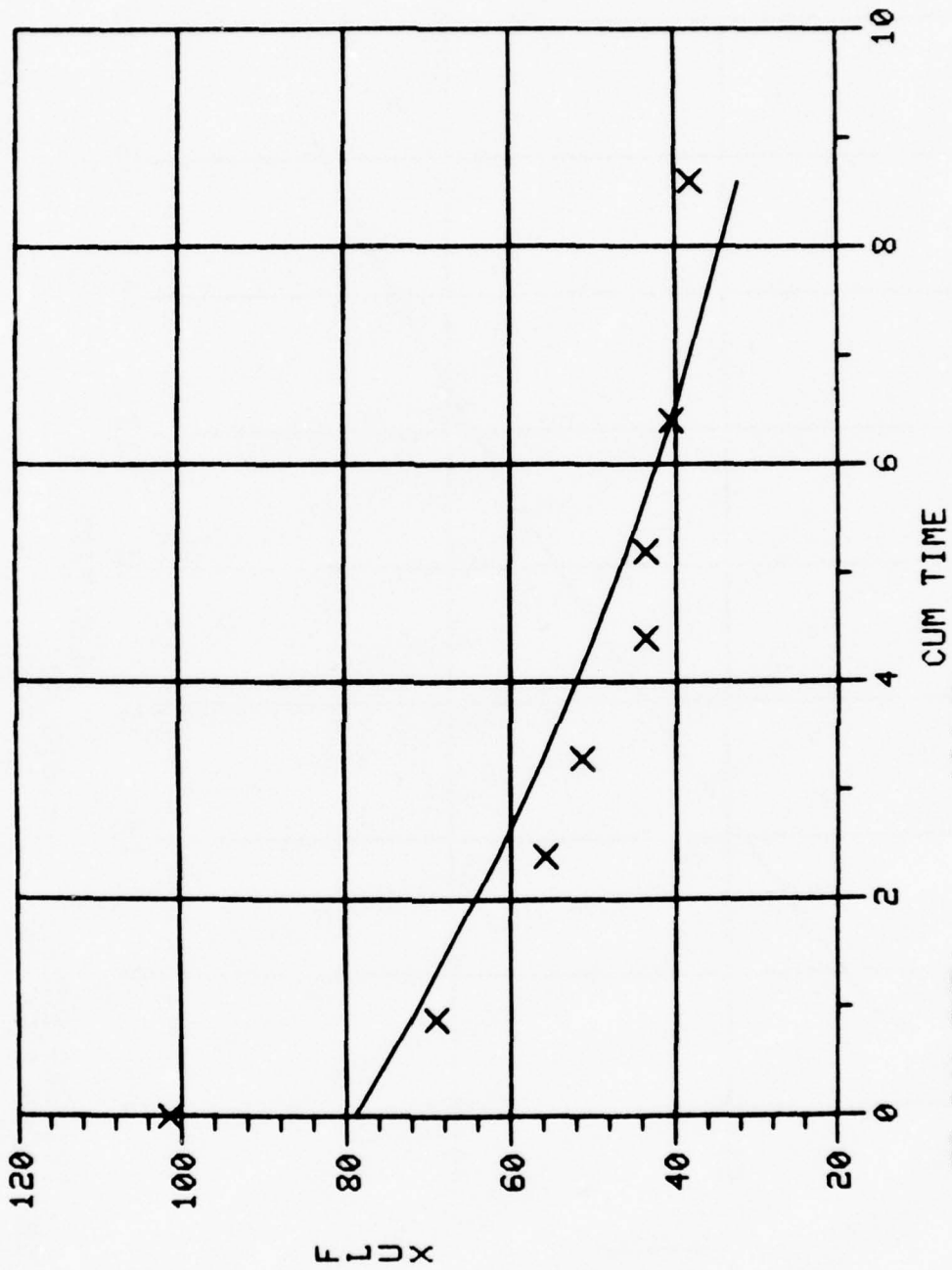

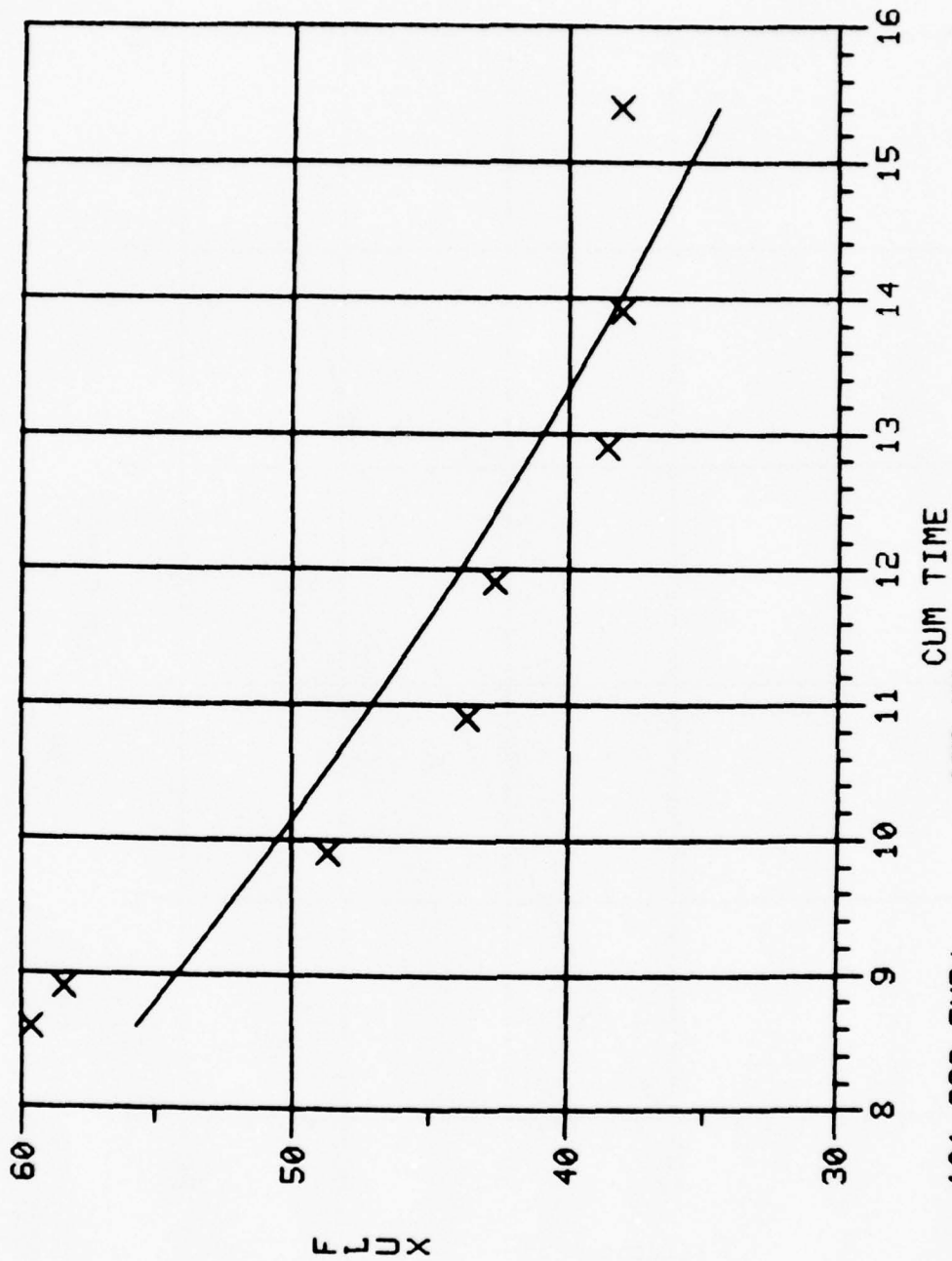

Y = 101.989 EXP(-.070 X)
 SO MULT CORR COEF IS .861

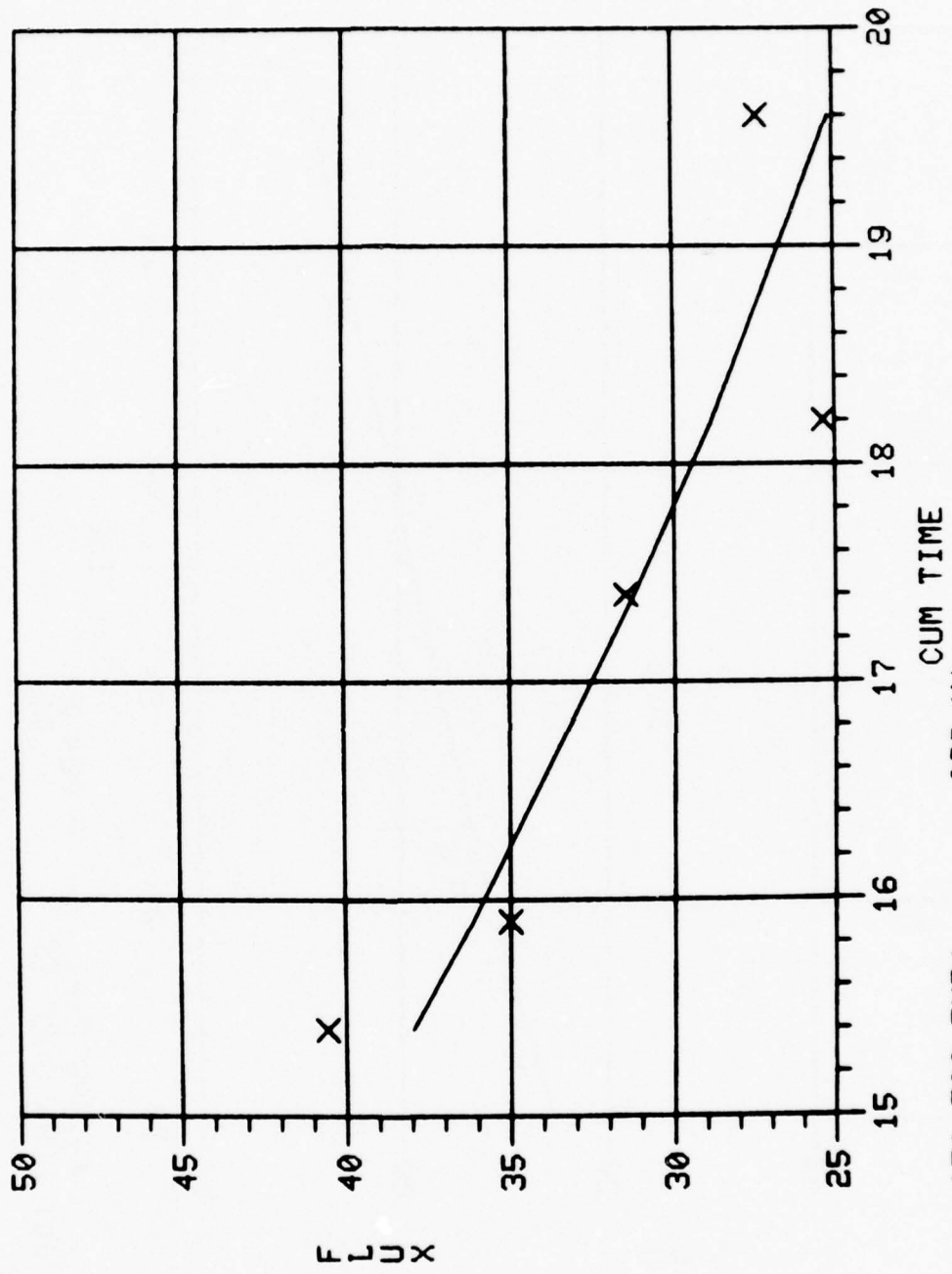

Y = 171.700 EXP(-.098 X)
 SQ MULT CORR COEF IS .792

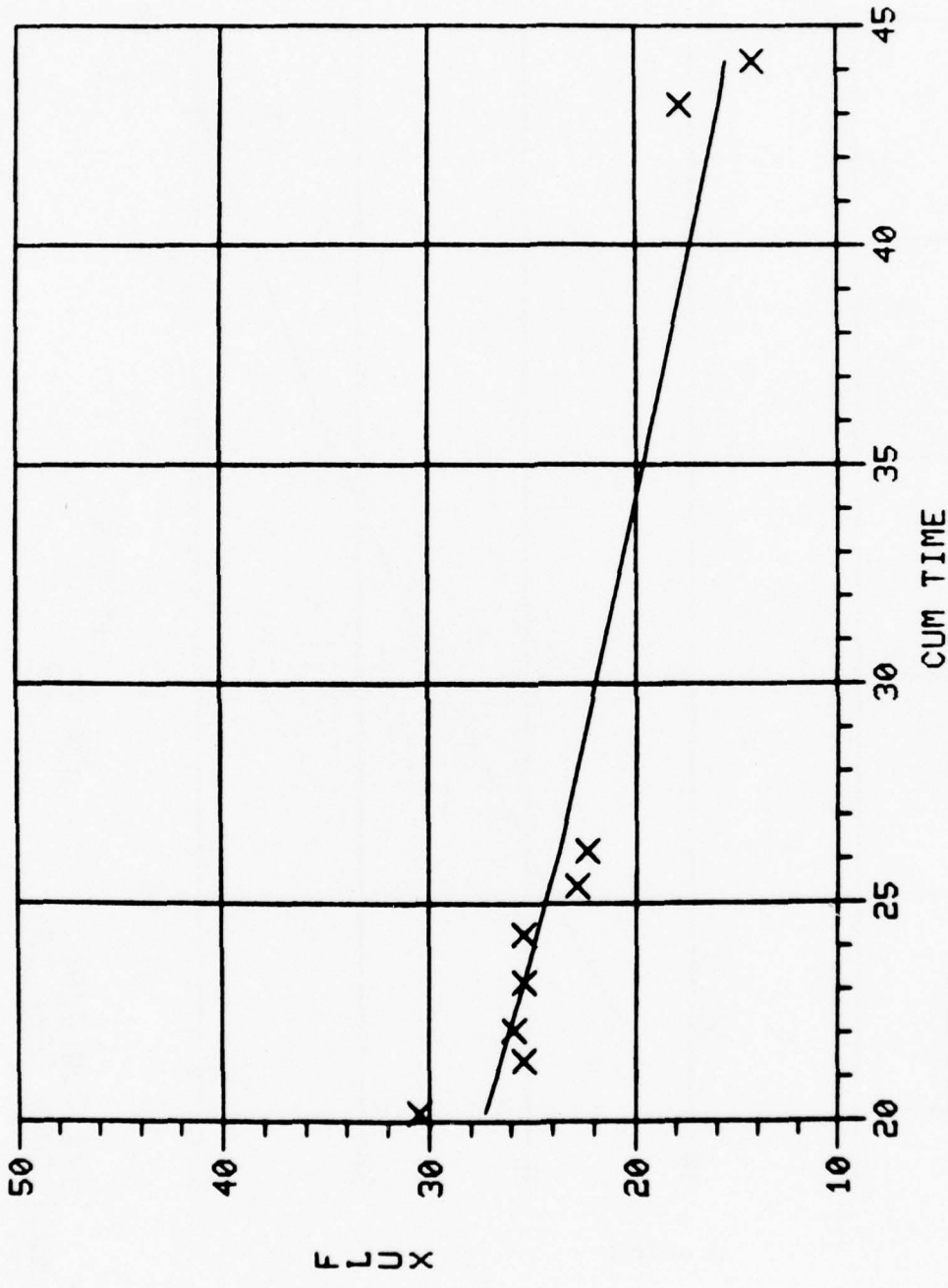

Y = 43.928 EXP(-.024 X)
 SQ MULT CORR COEF IS .901

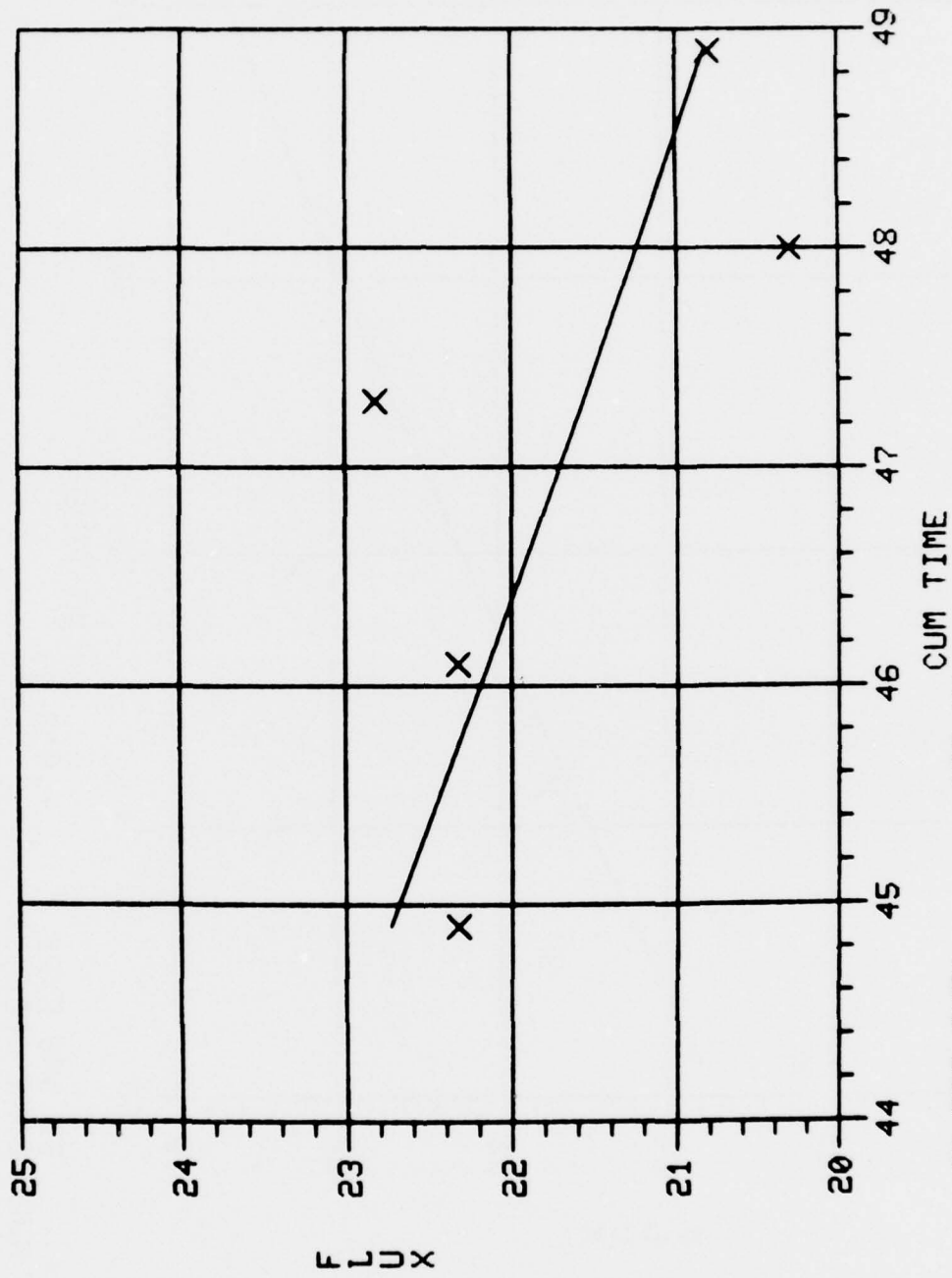

Y = 60.598 EXP(-.022 X)
 SQ MULT CORR COEF IS .456

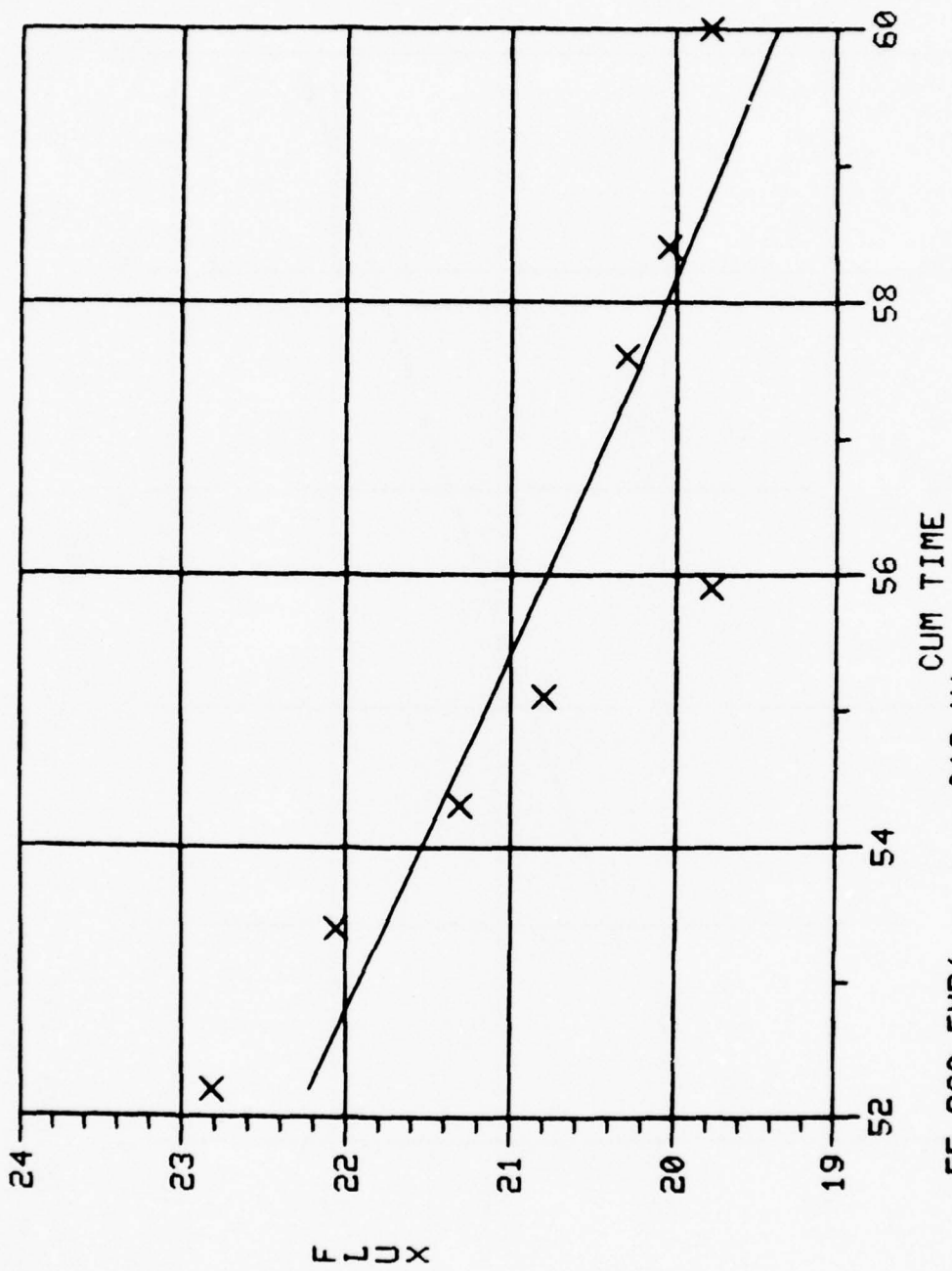

$Y = 55.960 \text{ EXP}(-.018 X)$
 SQ MULT CORR COEF IS .782

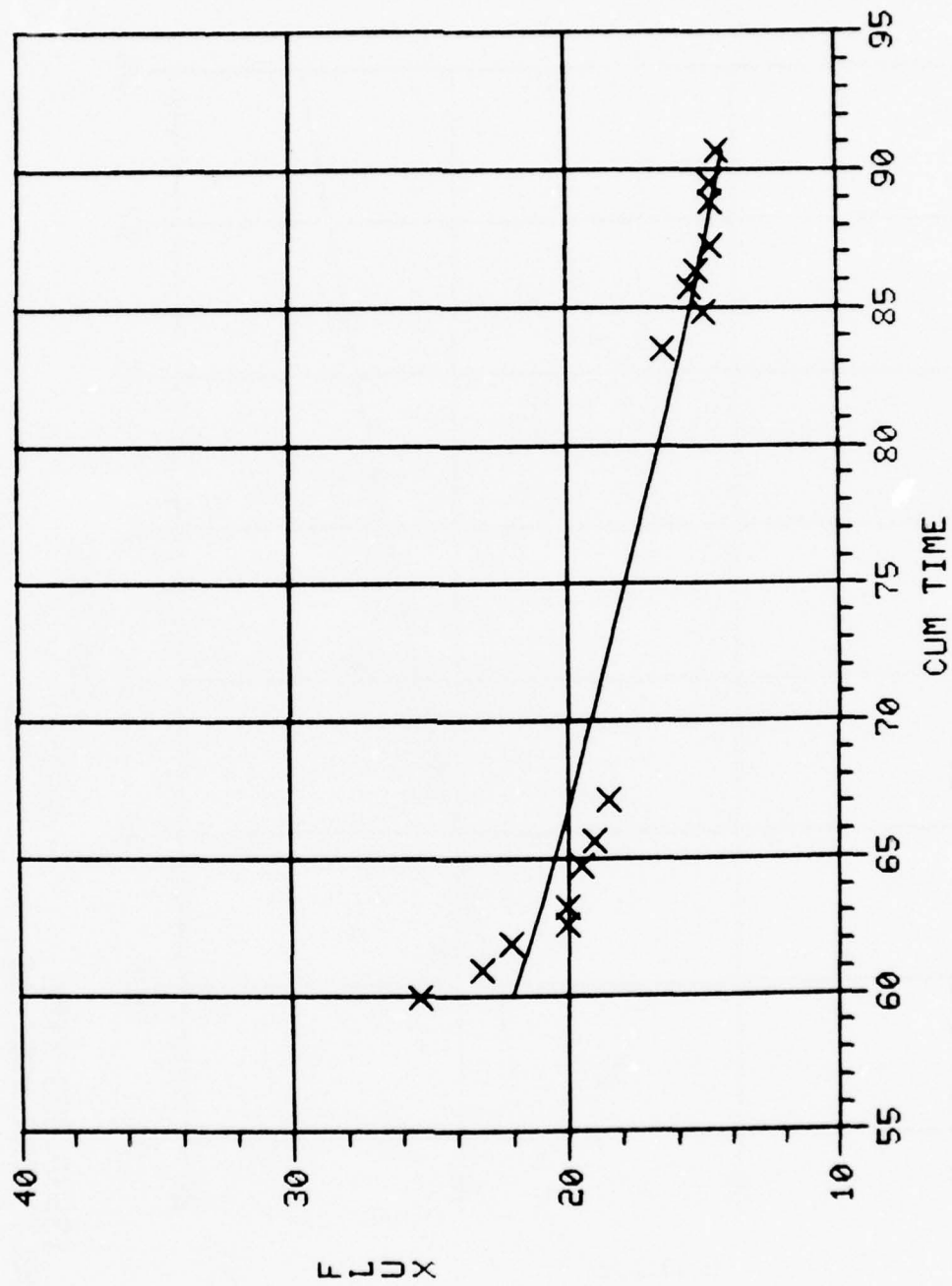

Y = 51.074 EXP(-.014 X)
 SQ MULT CORR COEF IS .910

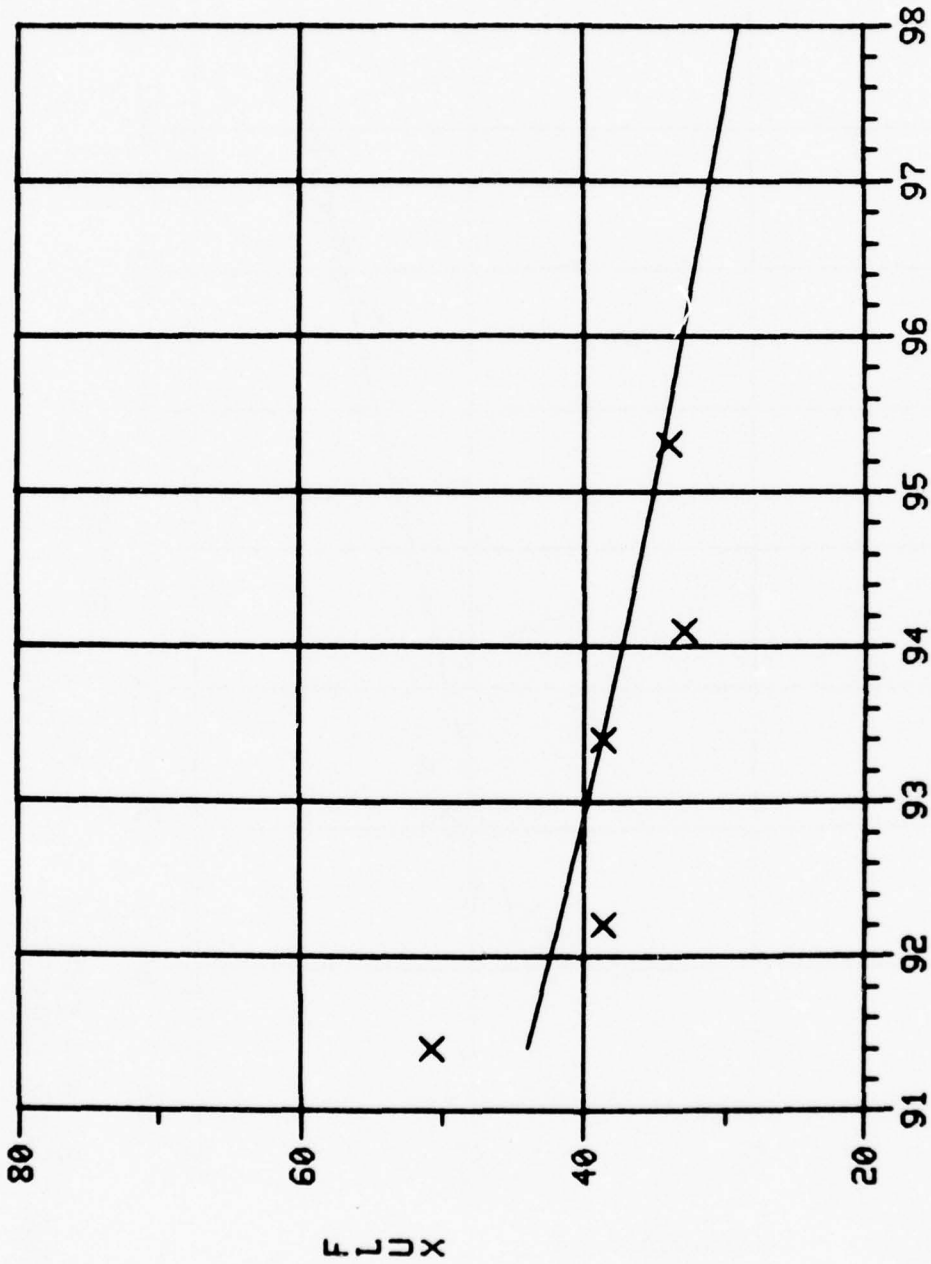

CUM TIME

Y = 13539.893 EXP(-.063 X)
 SO MULT CORR COEF IS .710

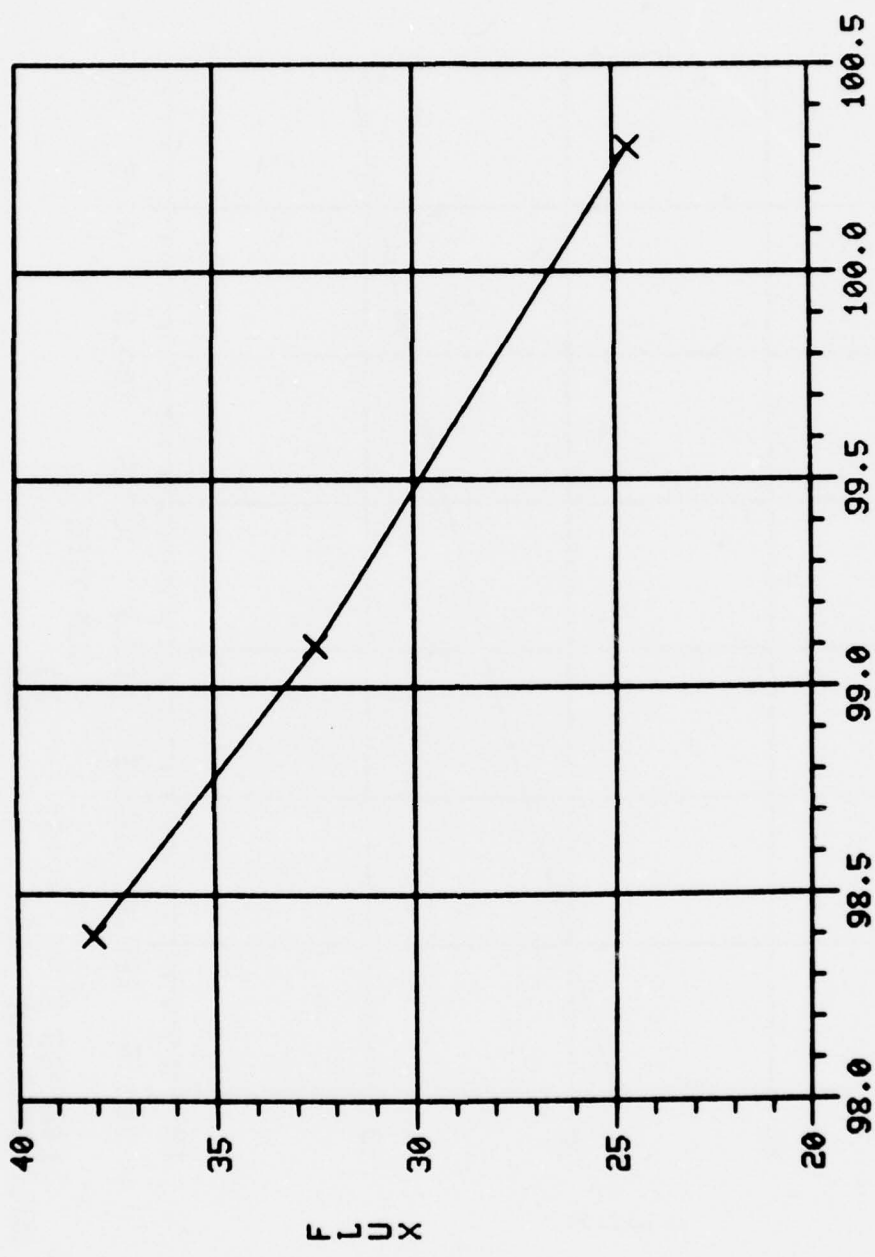

$Y = .247E+12 \text{ EXP}(-.230 X)$
 SQ MULT CORR COEF IS 1.000

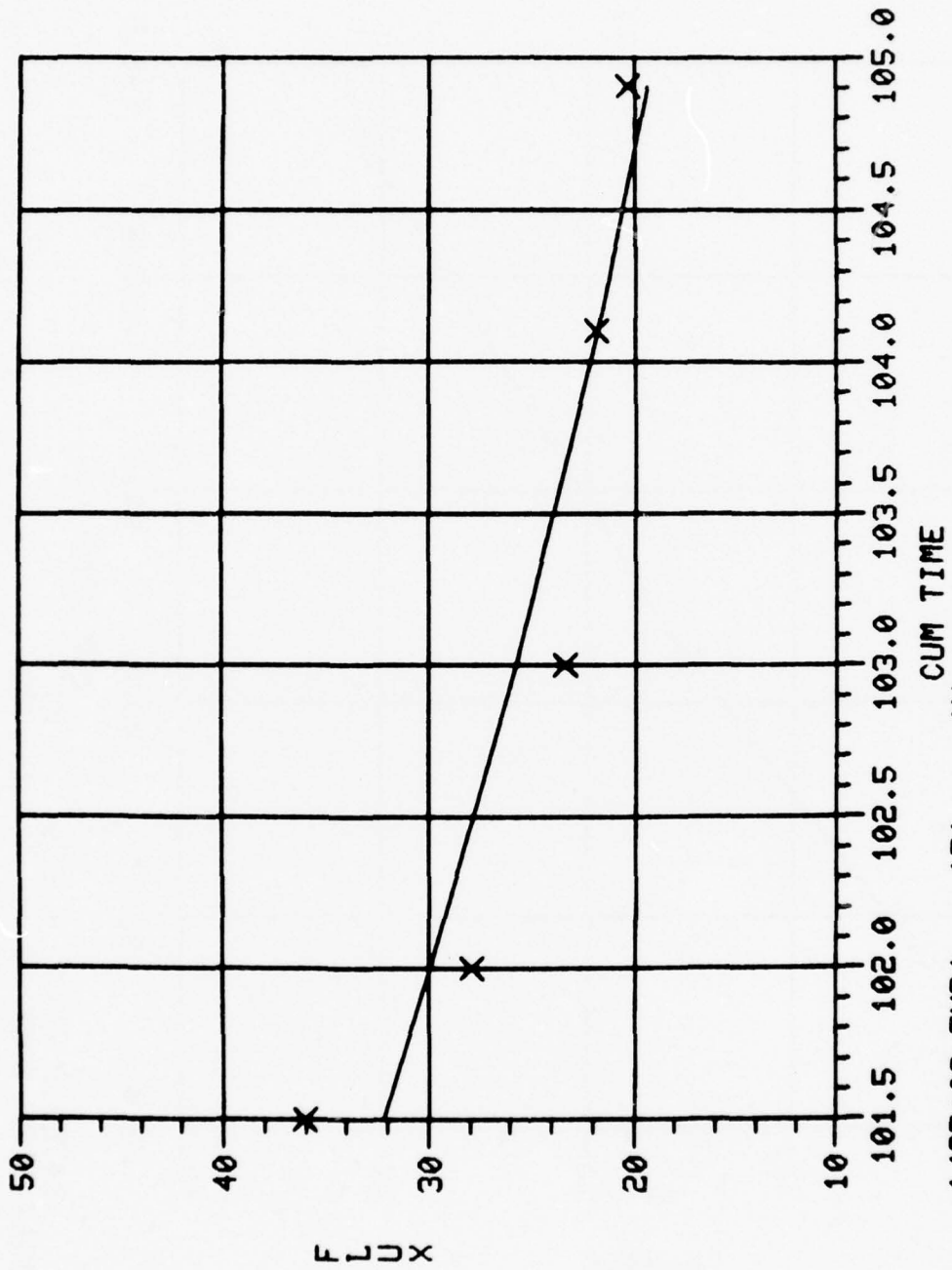

Y = .142E+09 EXP(-.151 X)
 SQ MULT CORR COEF IS .863

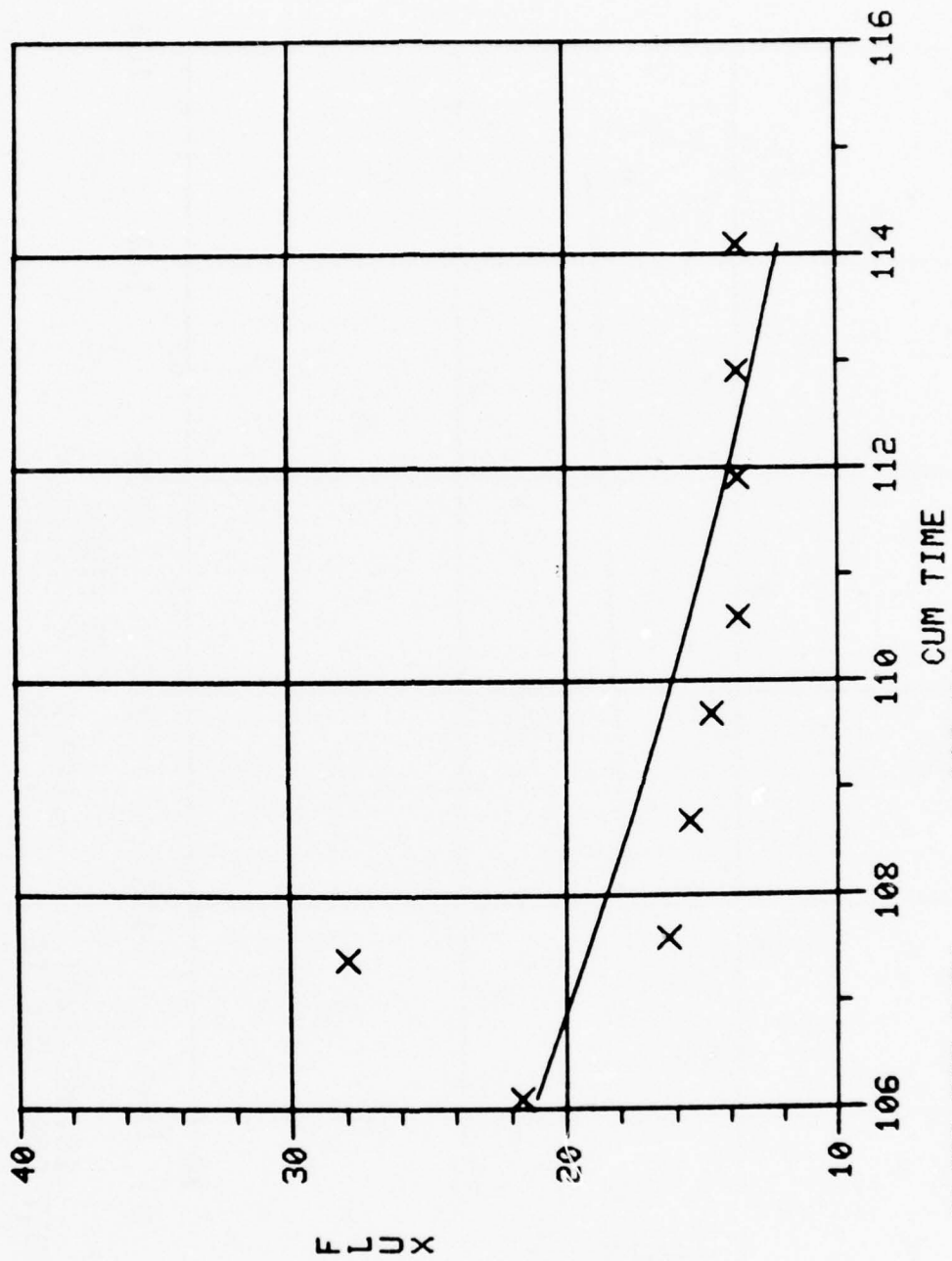

Y = 31499.595 EXP(-.069 X)
 SQ MULT CORR COEF IS .555

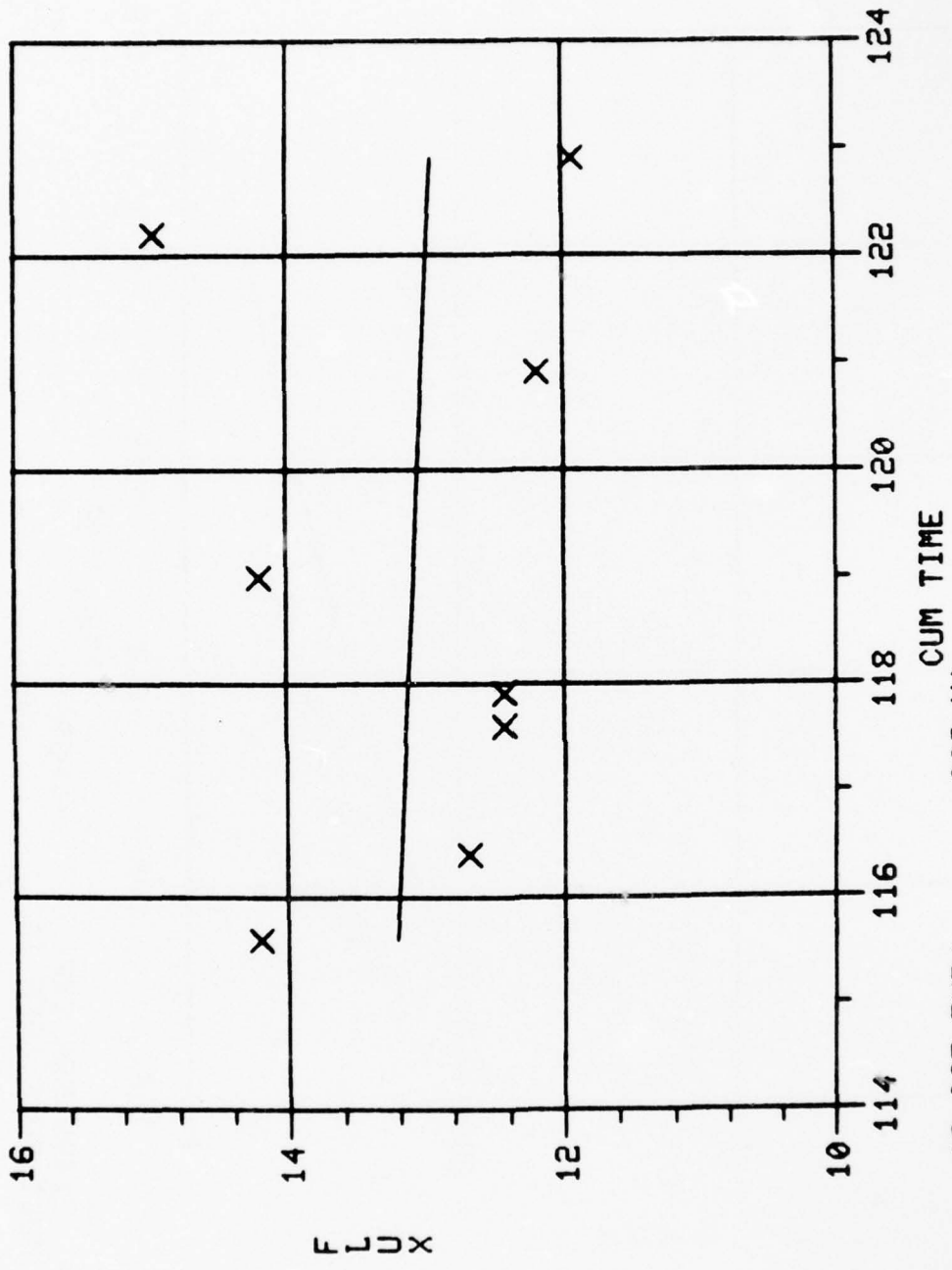

Y = 18.065 EXP(-.003 X)
 SQ MULT CORR COEF IS .007

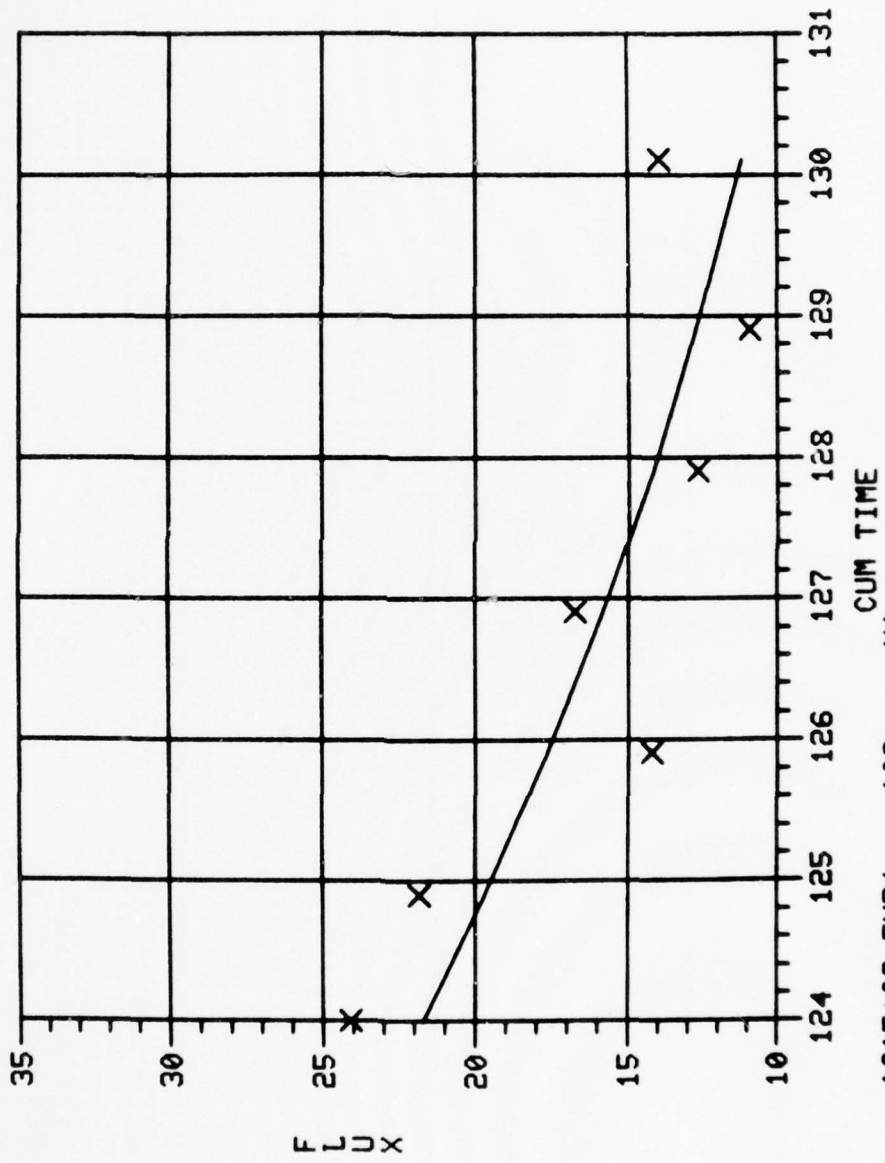

$Y = .161E+08 \text{ EXP}(-.109 X)$
 SQ MULT CORR COEF IS .684

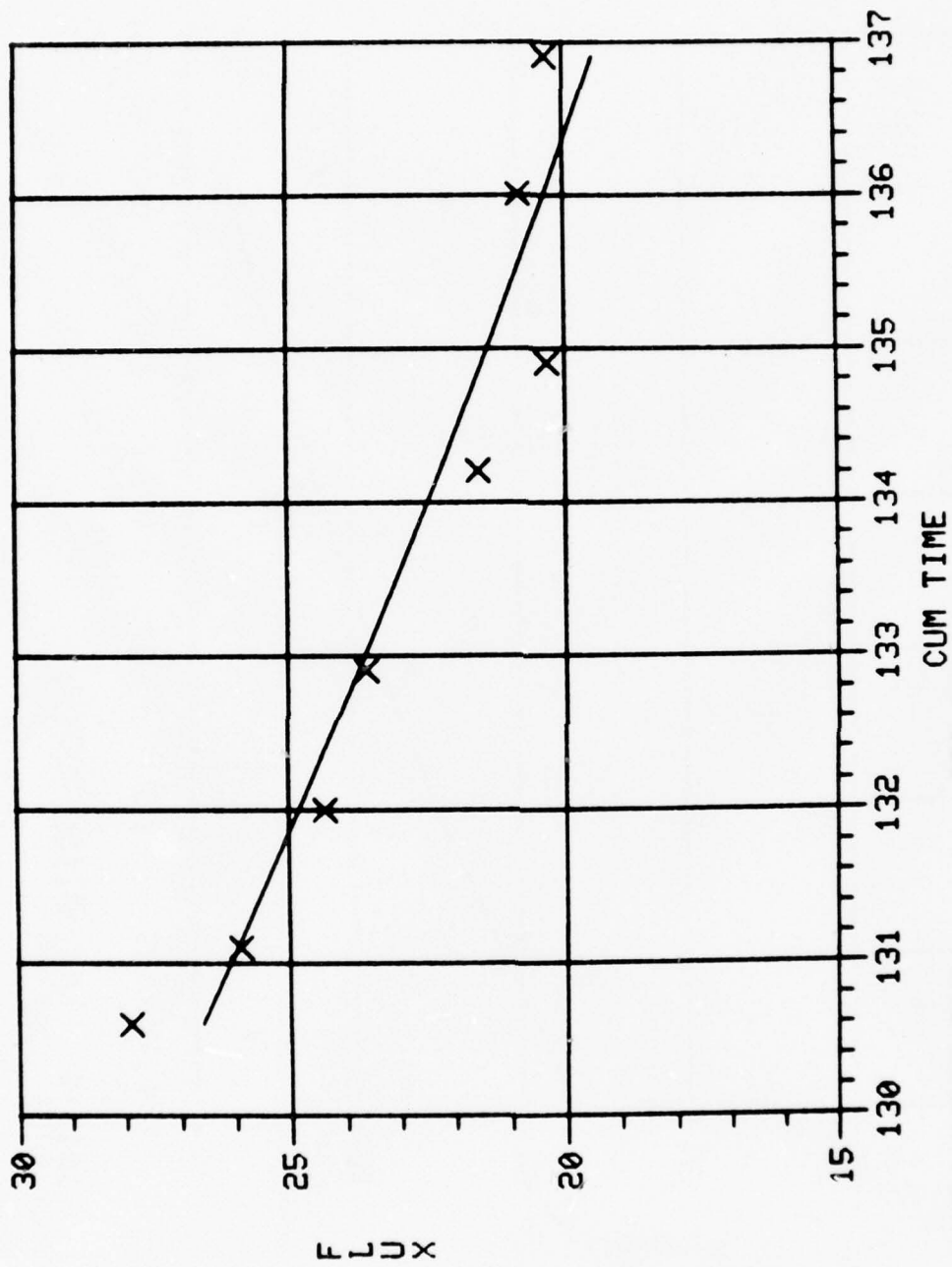

Y = 17448.565 EXP(-.050 X)
 SQ MULT CORR COEF IS .908

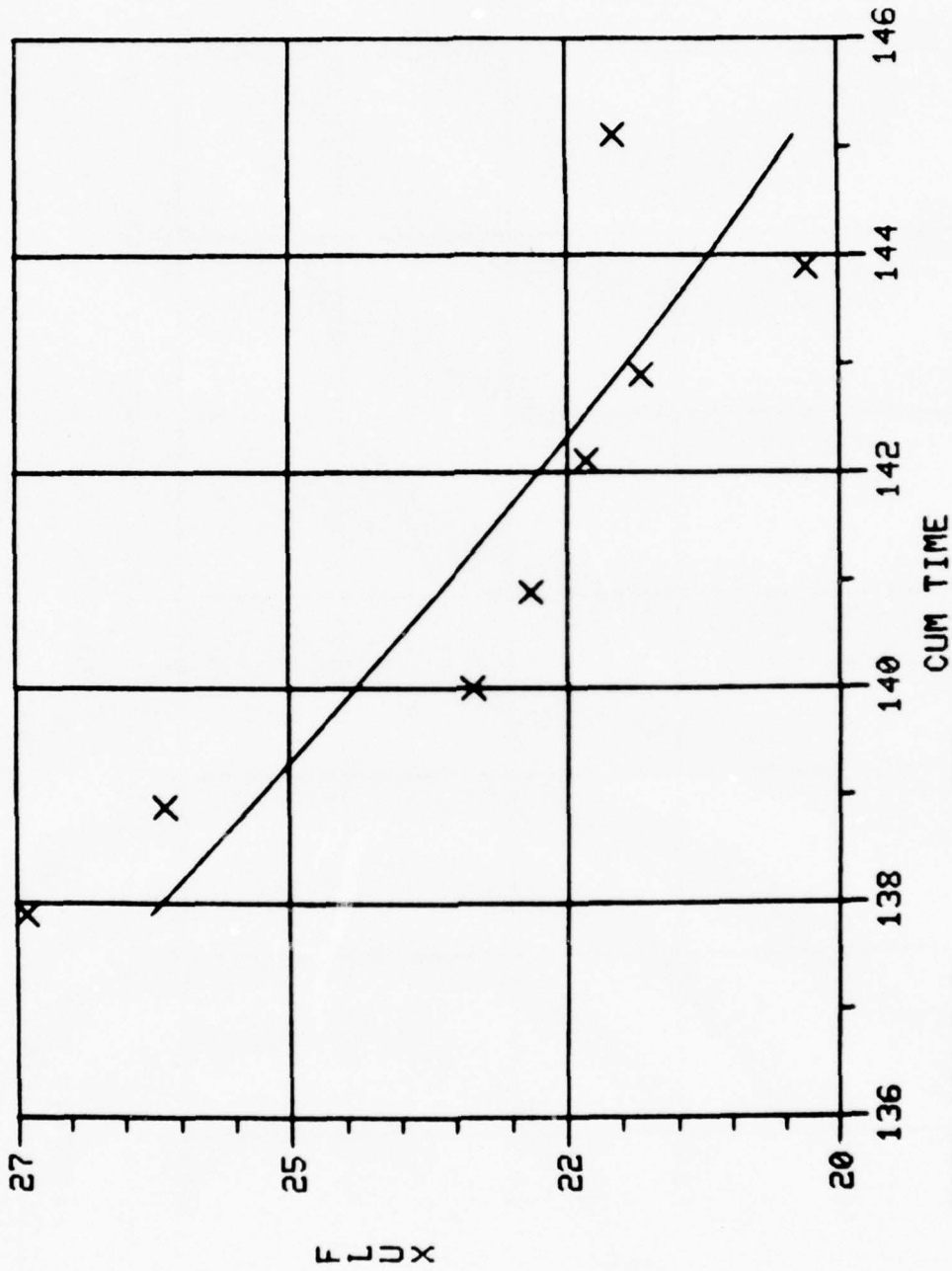

Y = 3276.034 EXP(SQ MULT CORR COEF IS - .035 X) .785

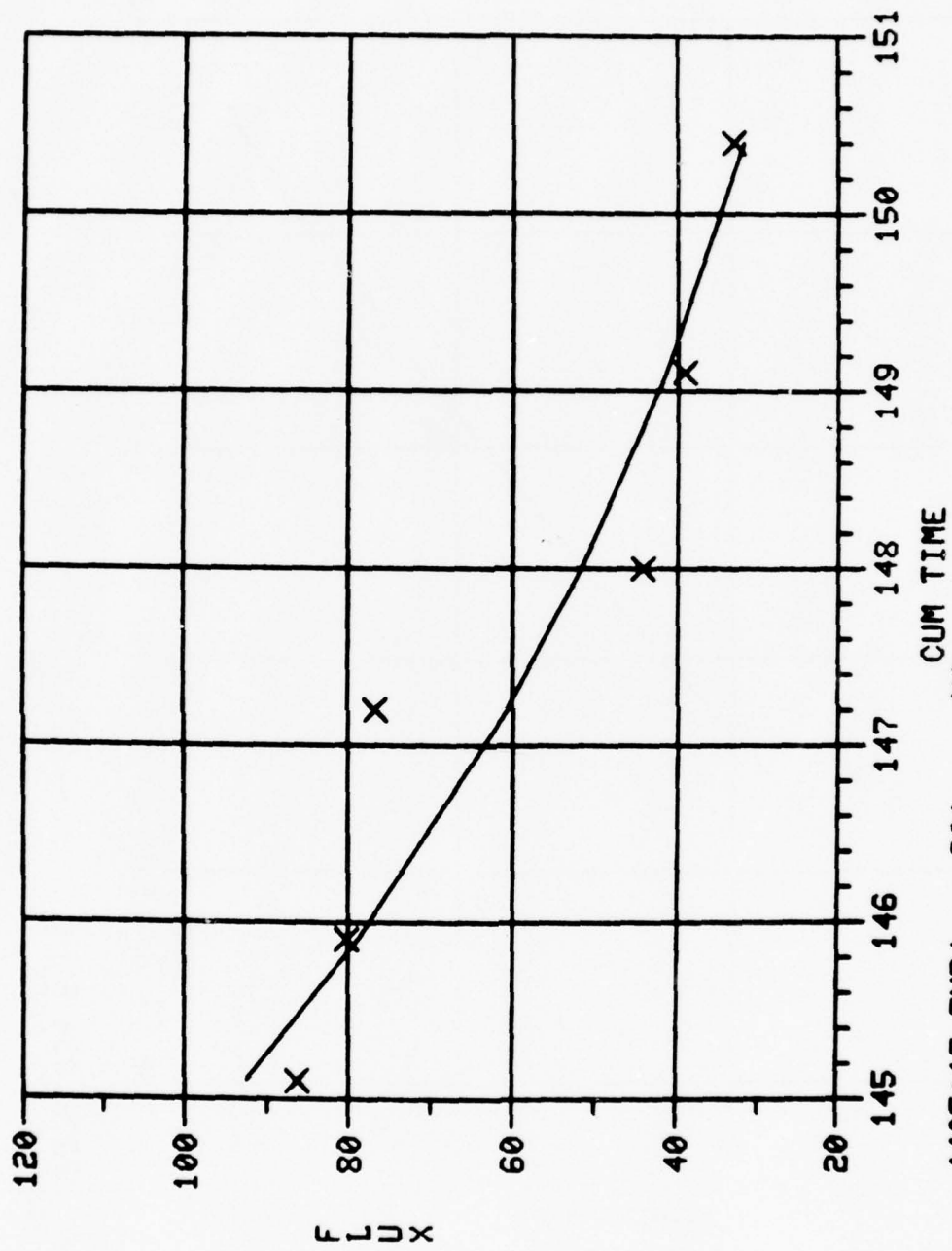

$Y = .440E+15 \text{ EXP}(-.201 X)$
 SQ MULT CORR COEF IS .898

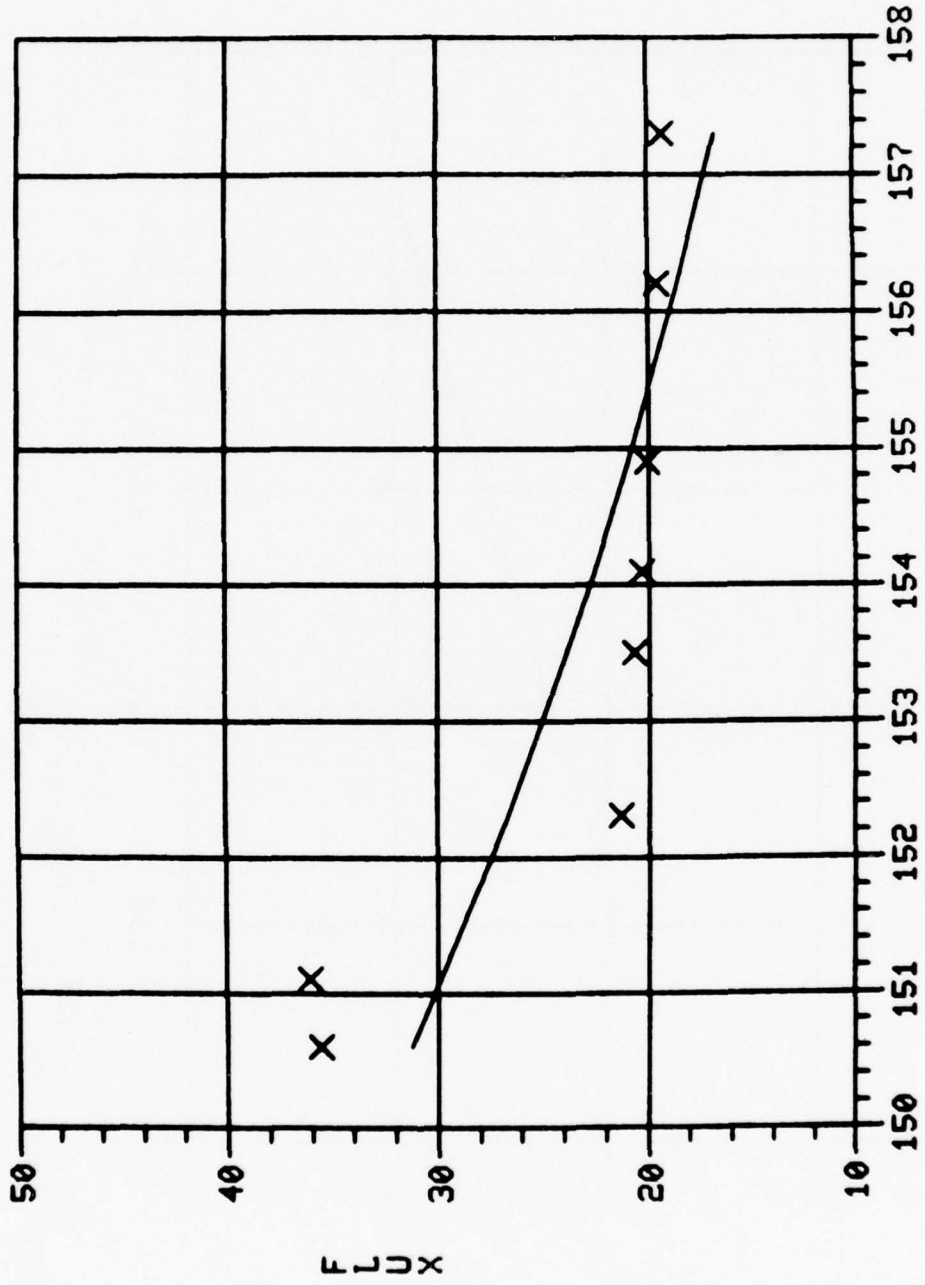

Y = .387E+08 EXP(-.932E-01 X)
 SO MULT CORR COEF IS .682

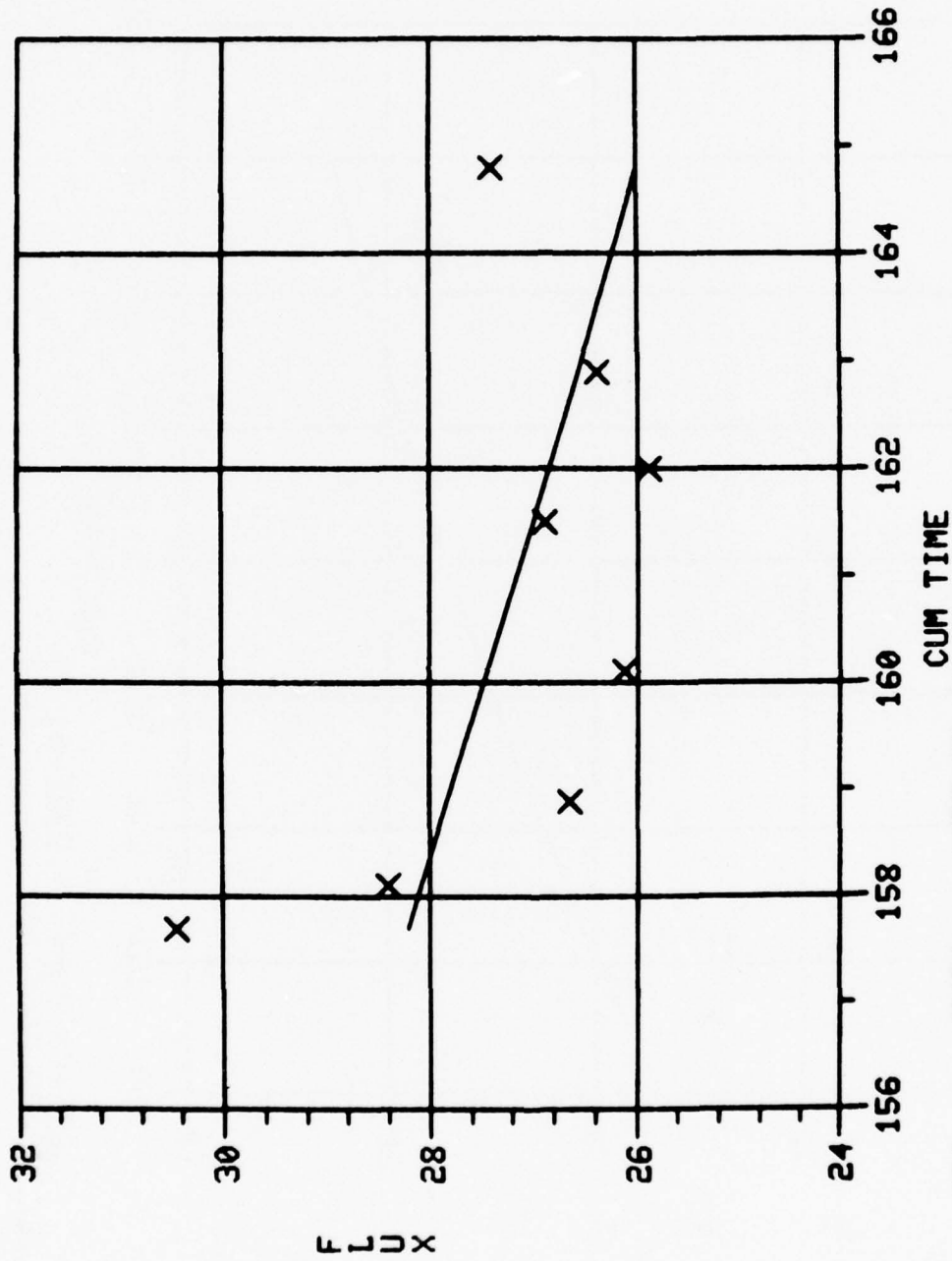

Y = 174. EXP(-.115E-01 X)
 SQ MULT CORR COEF IS .286

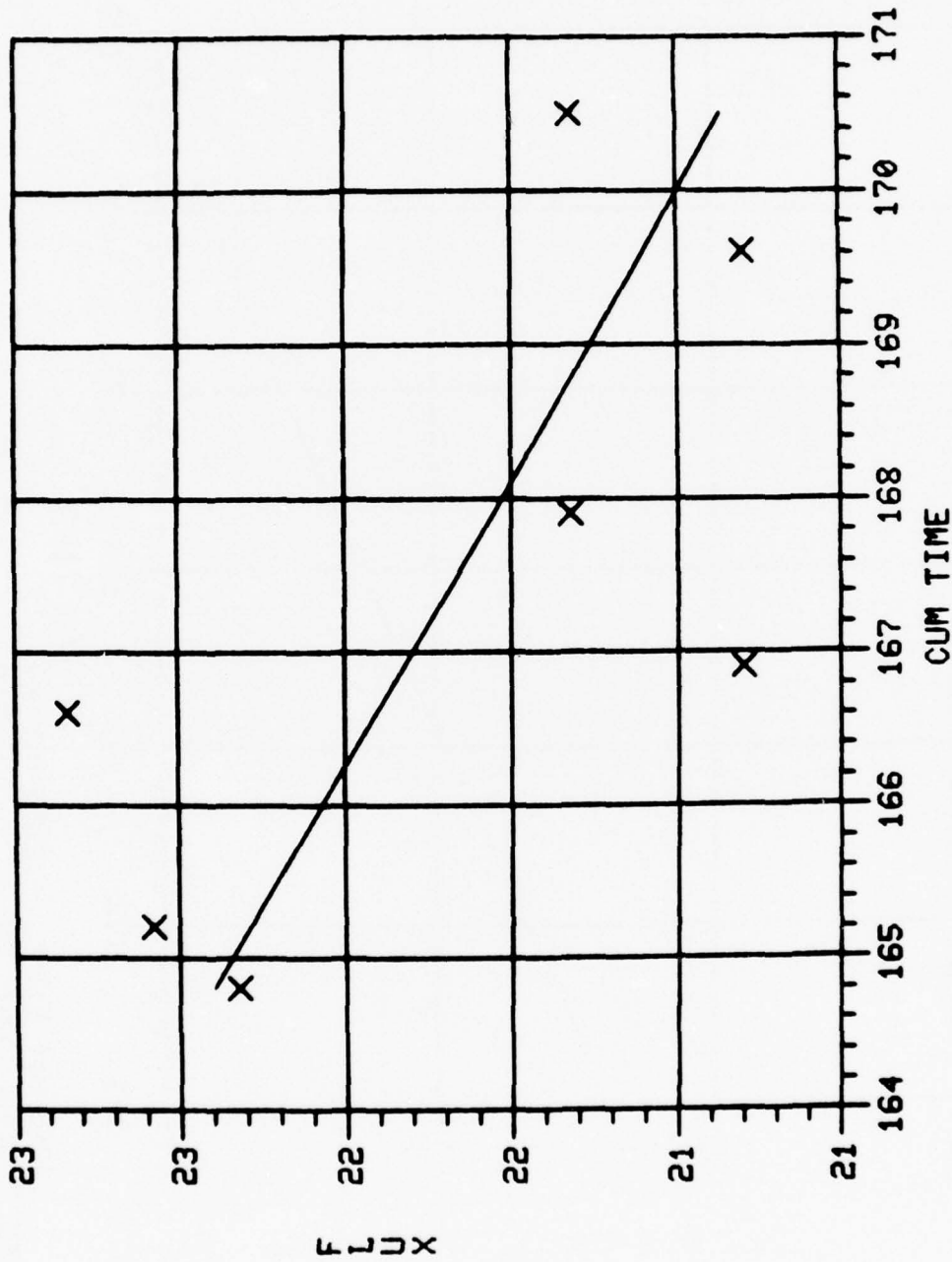

Y = 169. EXP(-.121E-01 X)
 SO MULT CORR COEF IS .455

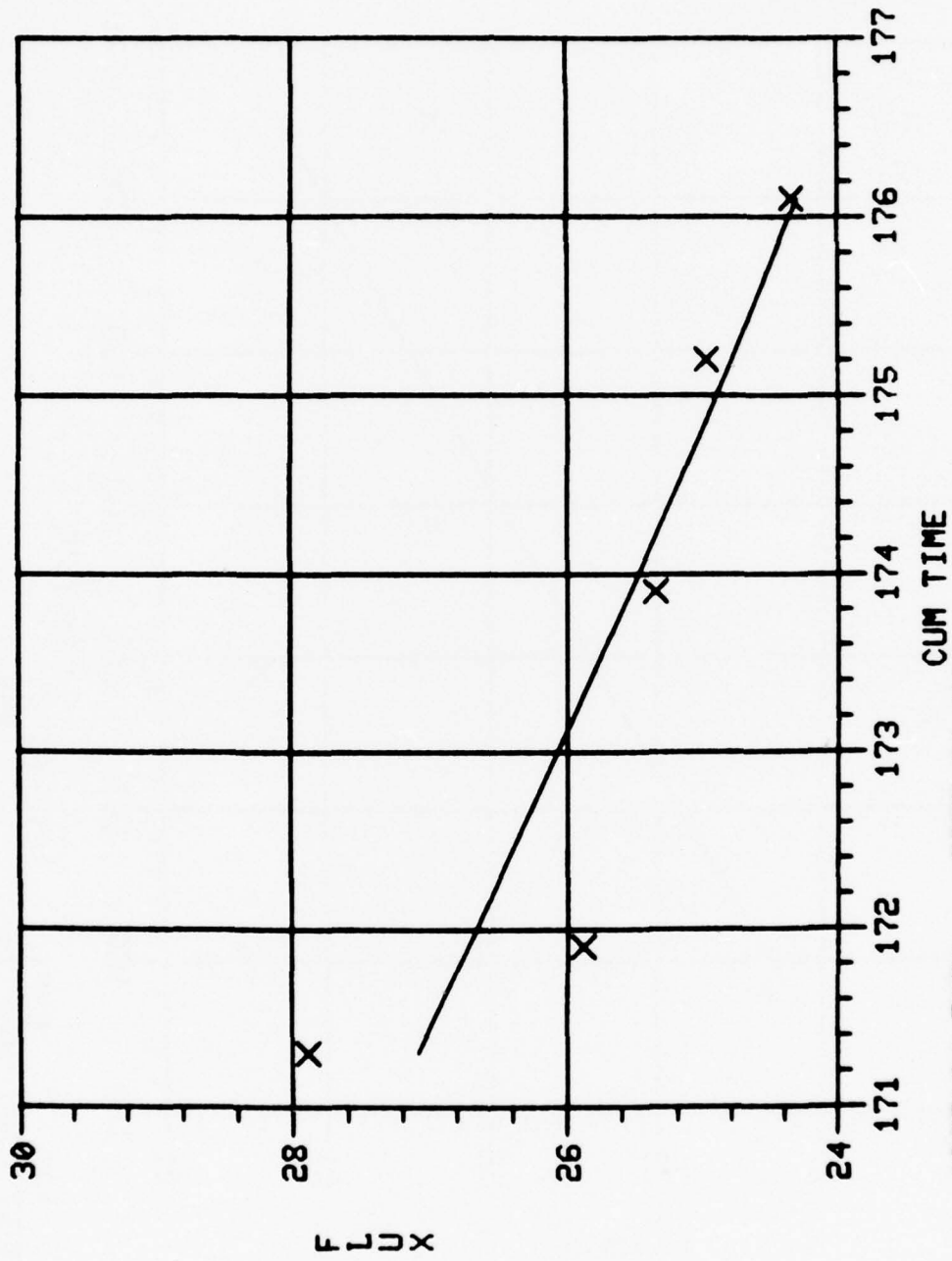

Y = .128E+04 EXP(-.225E-01 X)
 SQ MULT CORR COEF IS .815

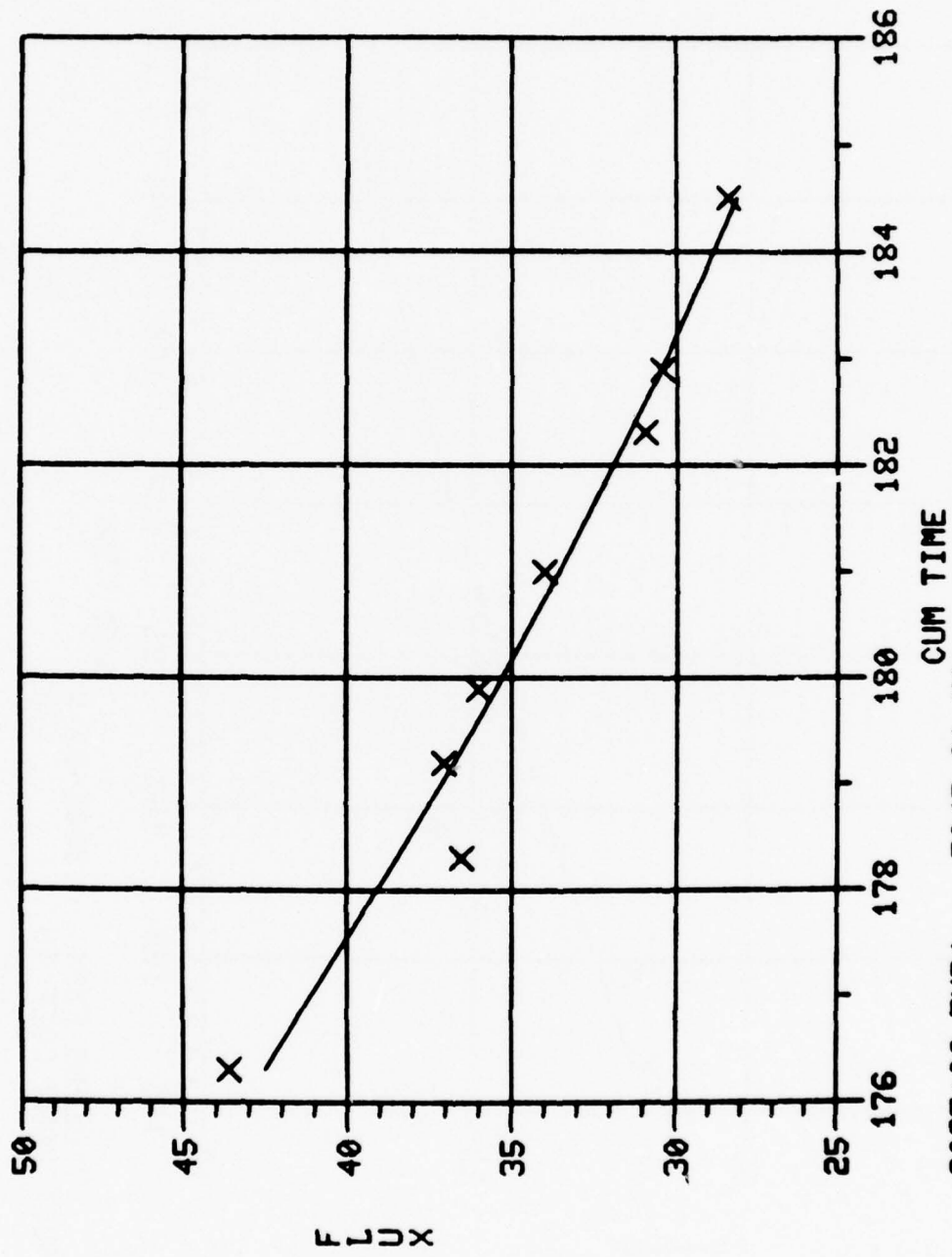

Y = .309E+06 EXP(-.504E-01 X)
 SO MULT CORR COEF IS .969

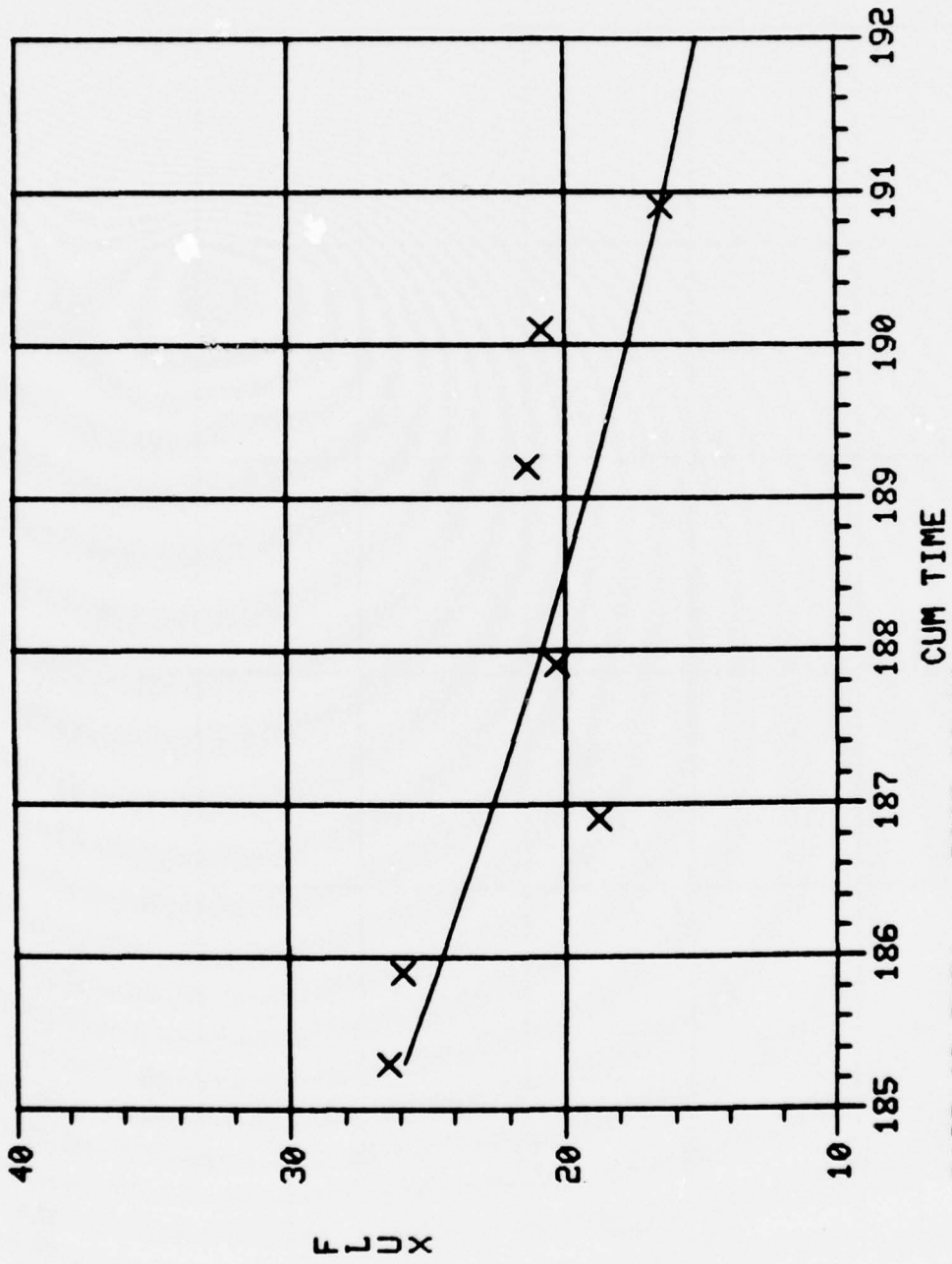

Y = .712E+08 EXP(-.800E-01 X)
 SQ MULT CORR COEF IS .721

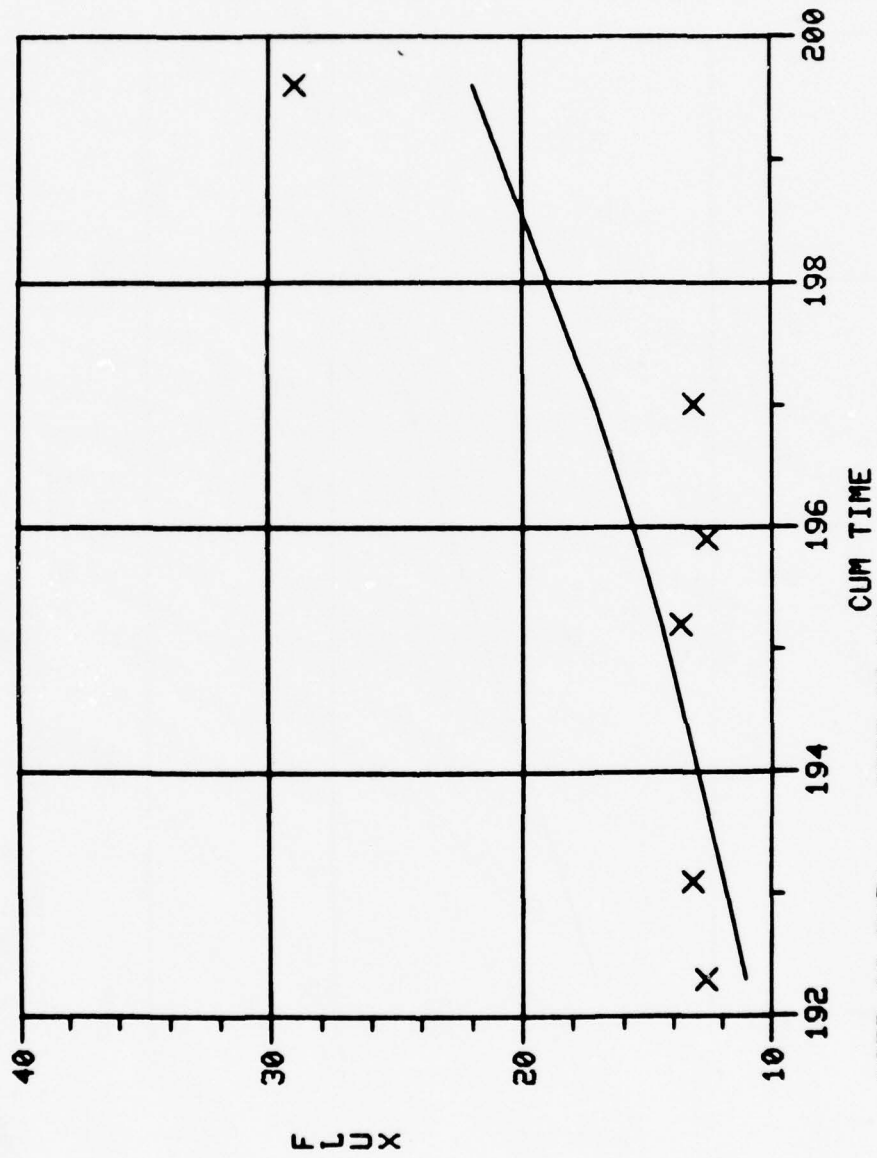

$Y = .167E-06 \text{ EXP} (.936E-01 X)$
 SO MULT CORR COEF IS .585

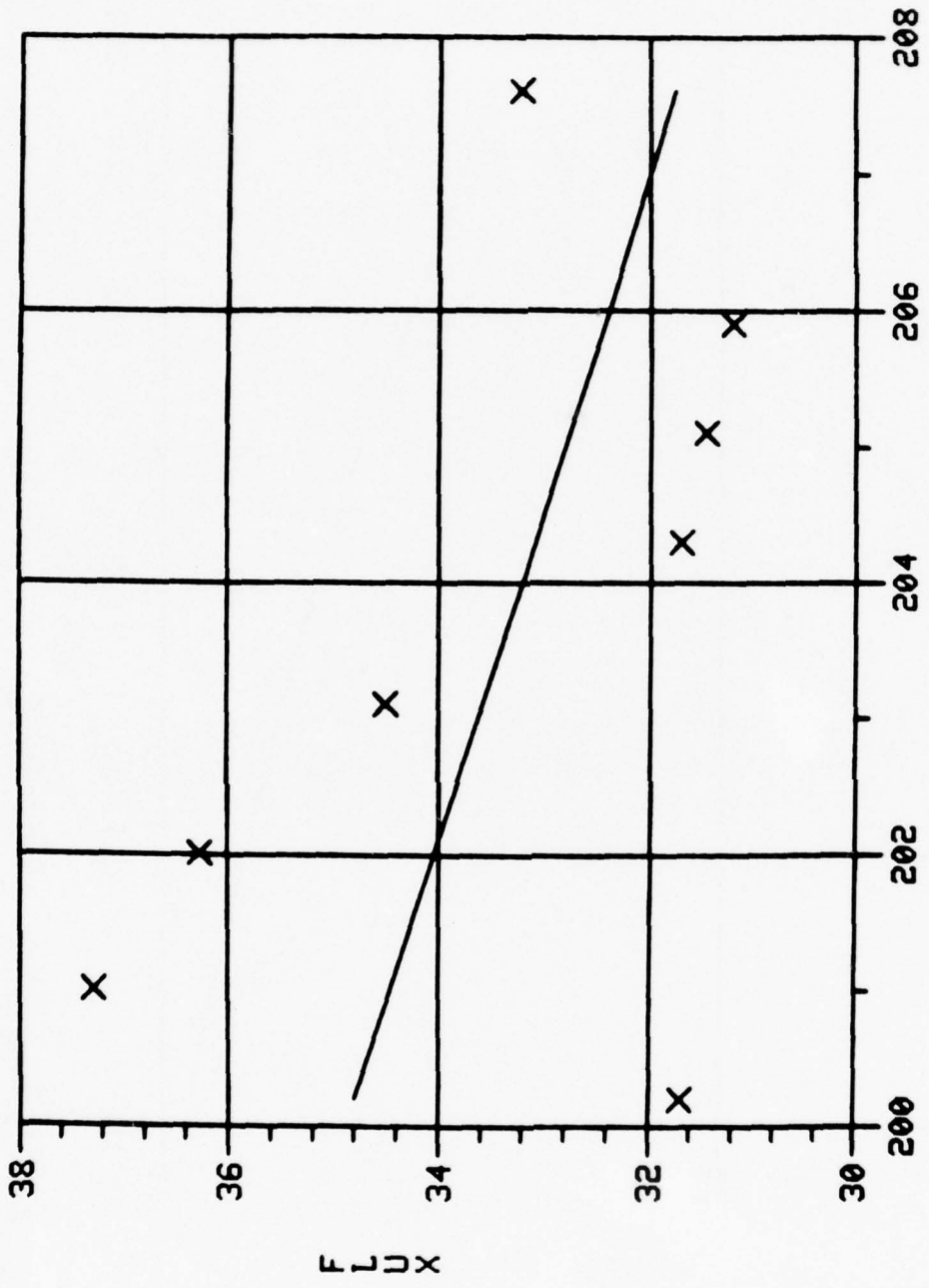

Y = 417. EXP(-.124E-01 X)
 SQ MULT CORR COEF IS .207

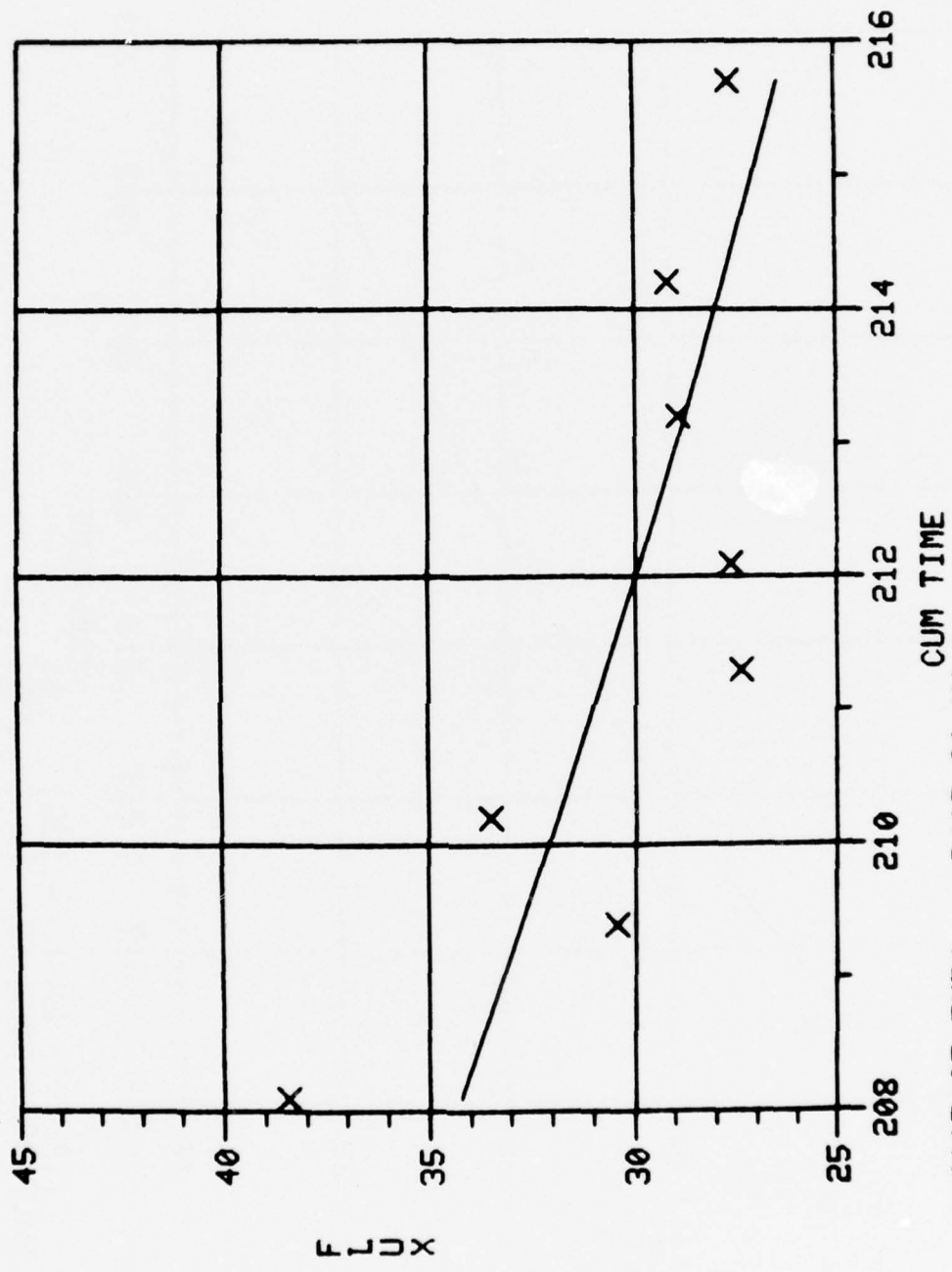

Y = .411E+05 EXP(-.341E-01 X)
 SQ MULT CORR COEF IS .543

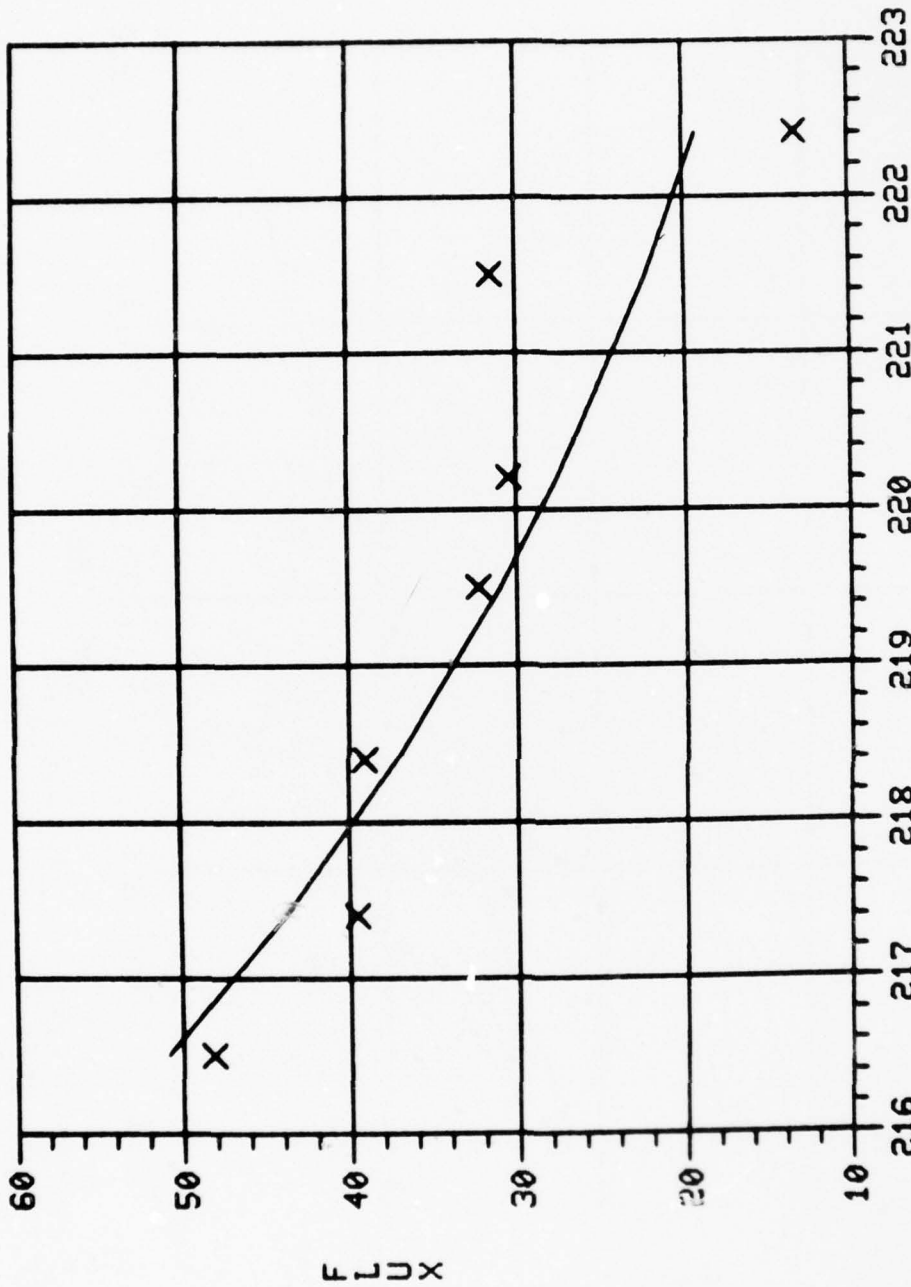

CUM TIME

Y = .185E+18 EXP(-.165 X)
 SQ MULT CORR COEF IS .723

APPENDIX E

CURVE FITS FOR SEGMENTED, SPIRAL-WOUND DATA

The data for the spiral-wound system was segmented at what appeared to be the point where the system reached steady state. Three different points were picked which resulted in three groups of data each containing two segments. The points of division are 555.3, 560.2, and 575. Each group contains four graphs, a first-order and exponential fit for the presumed unsteady state portion of the data and the same two fits for the steady state portion of the data. It should be noted that in the two plots of the steady state for Group 2 there is an erroneous data point at 560 hours. A quirk in the graphics packages made inclusion of this point necessary, and it should have only a negligible effect on the equation and the coefficient of determination.

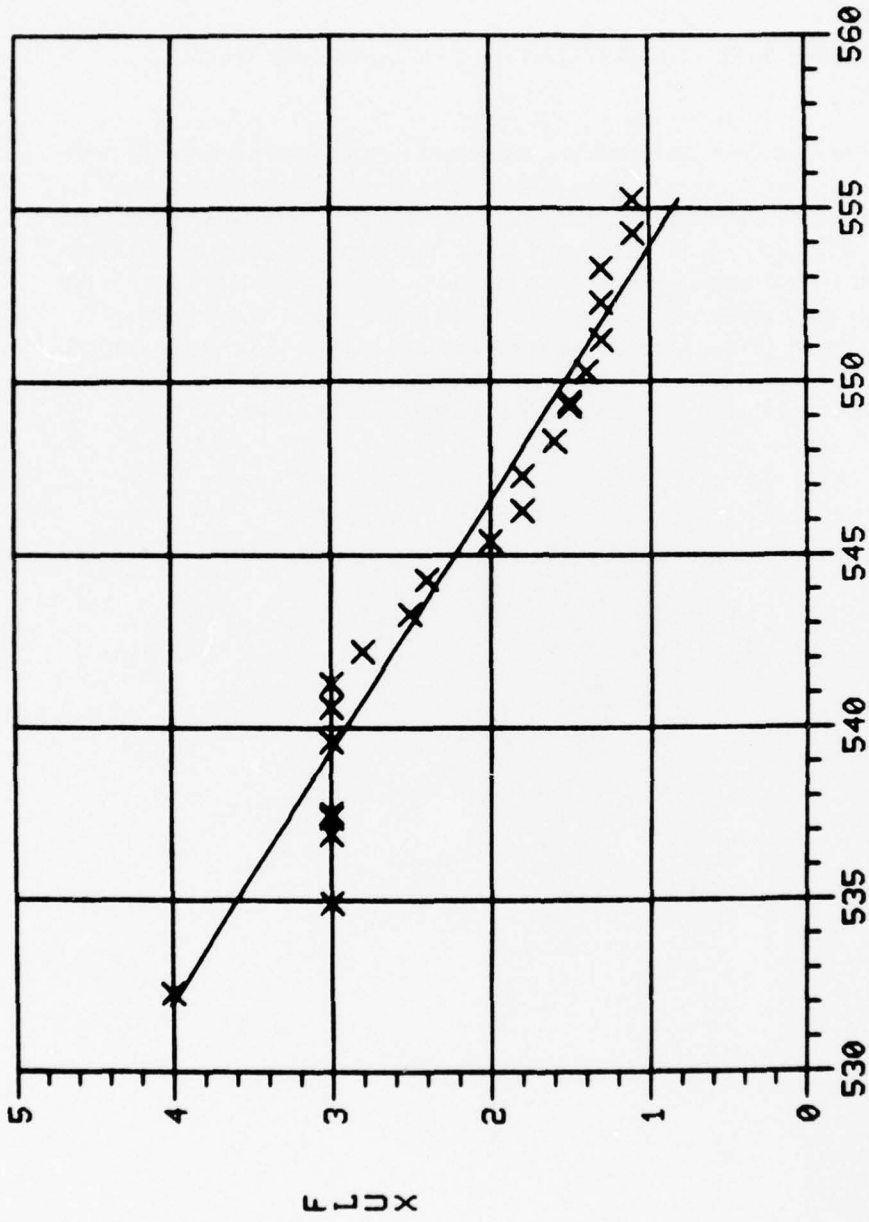

Y = -.137 X + 76.8105
 SQ MULT CORR COEF IS .910

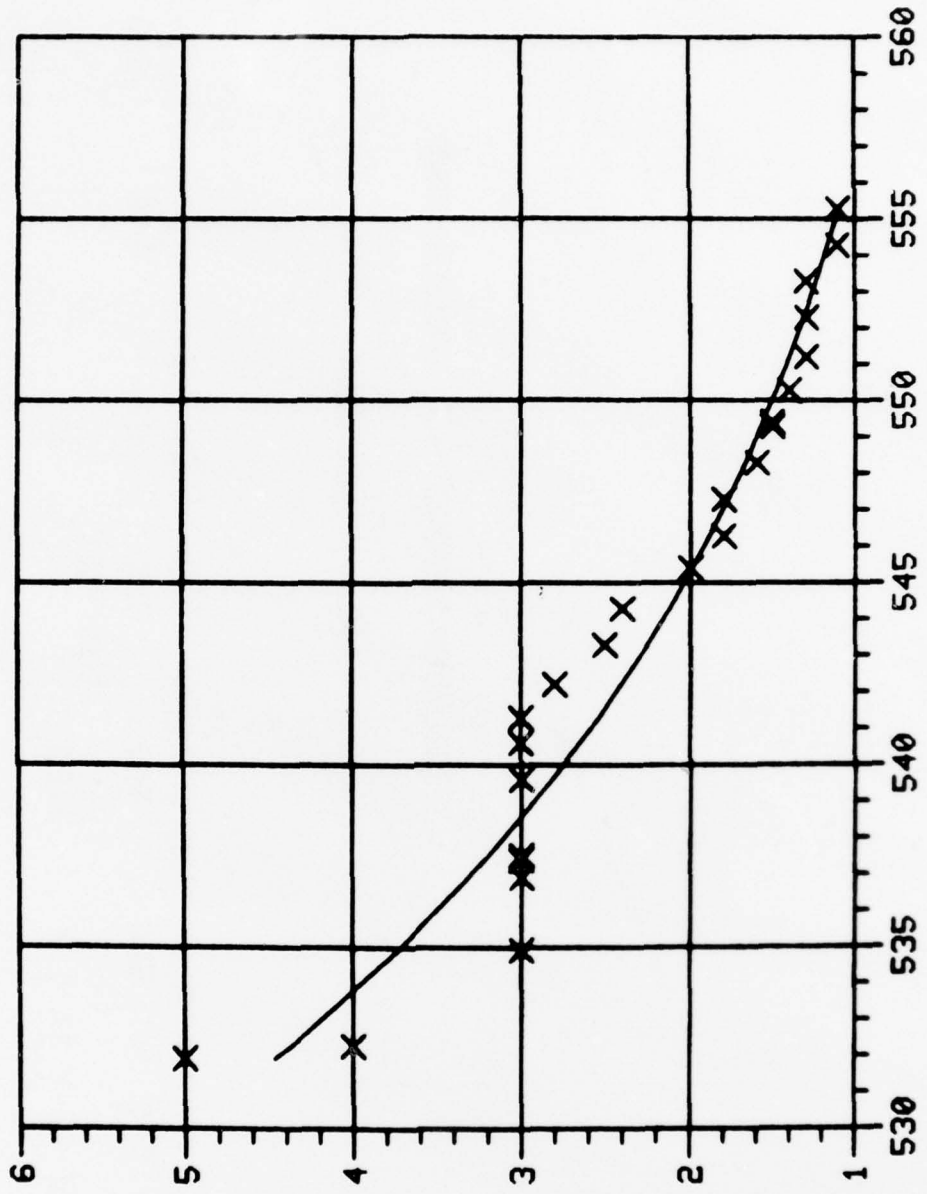

Y - XXXXXXXXXXXX EXP (- .060 X)
 SQ MULT CORR COEF IS .952

XPL

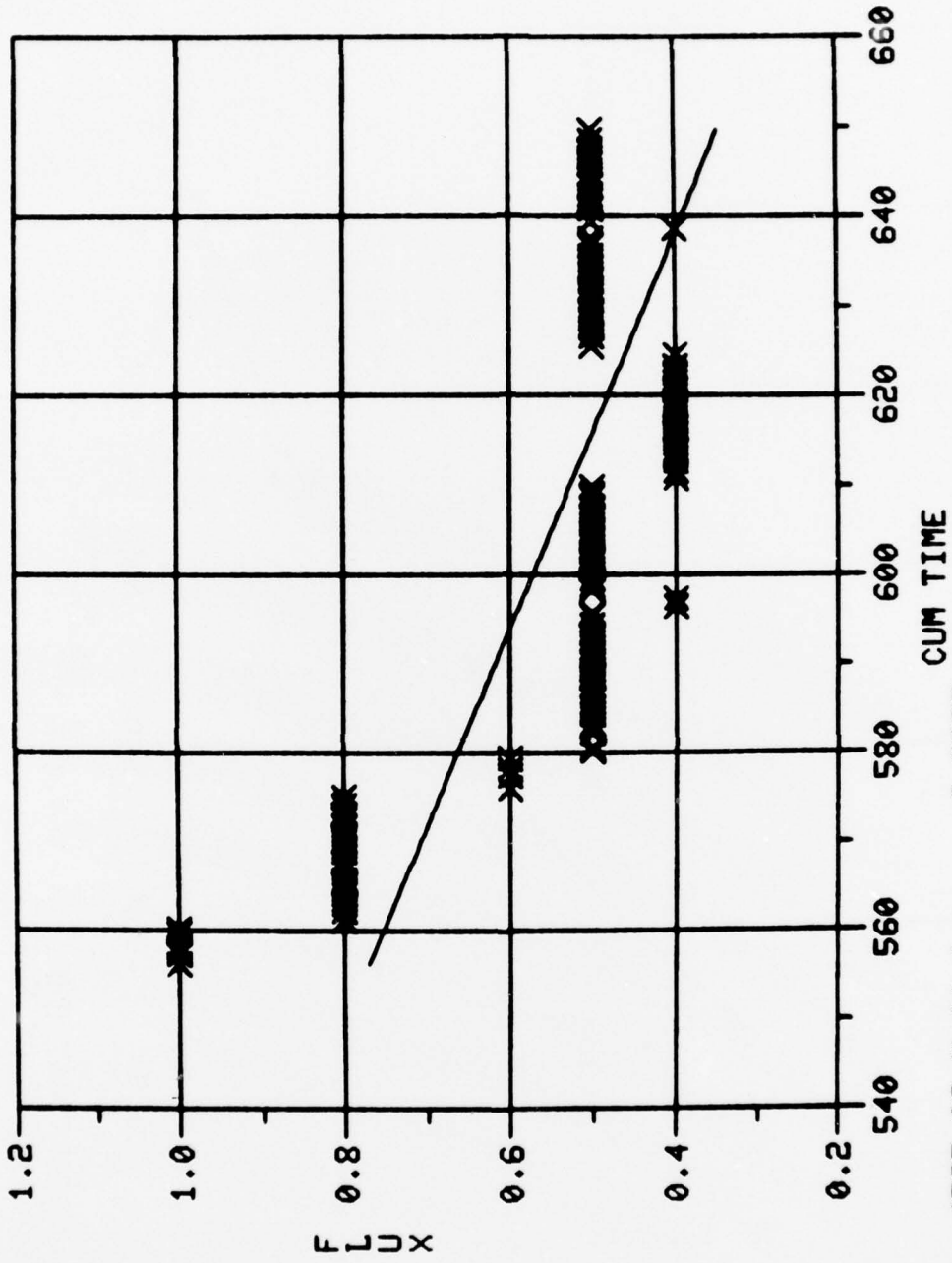

Y = -.452E-02 X XX 1 + SQ MULT CORR COEF IS 3.2857 .543

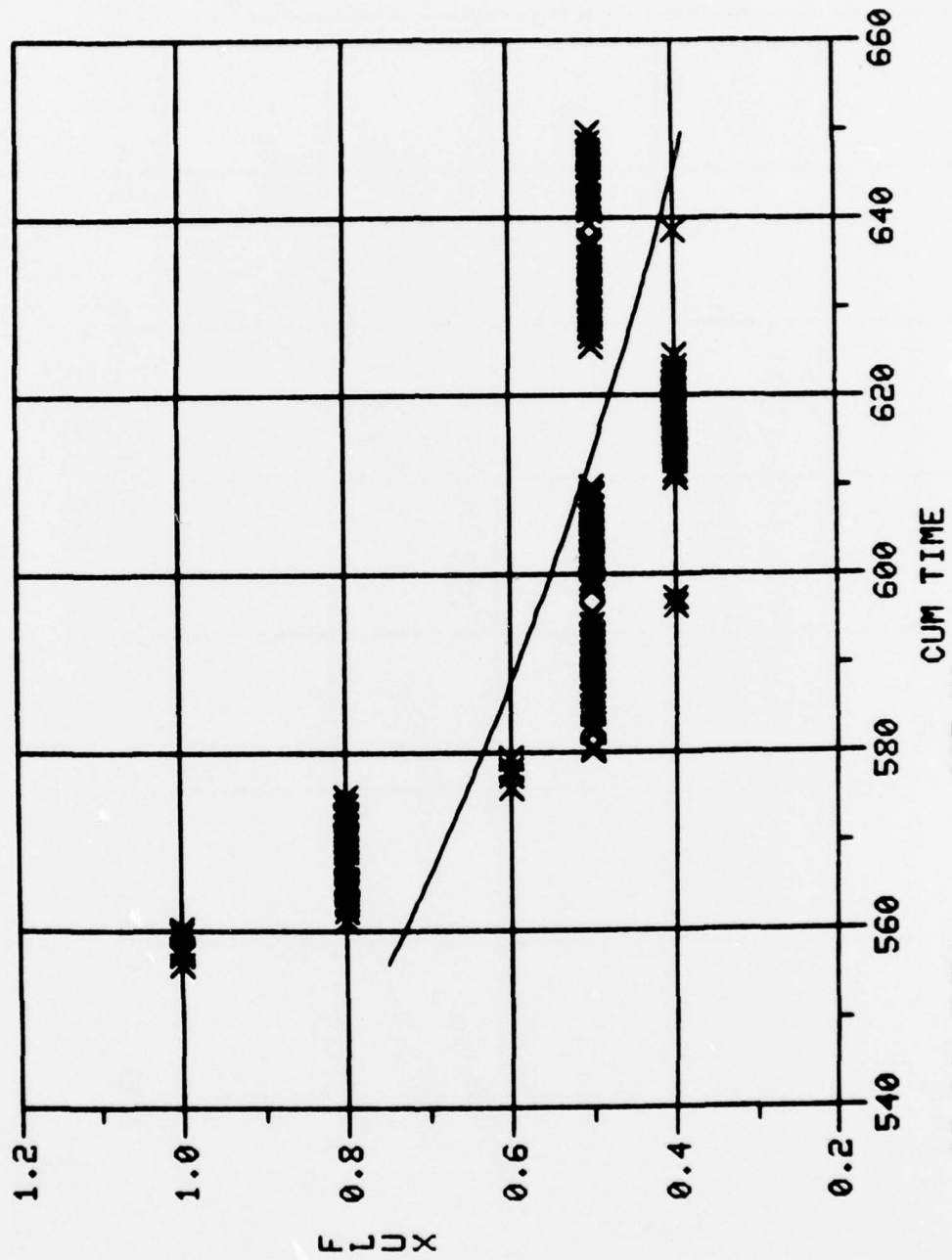

Y = 38.044 EXP(-.007 X)
 SO MULT CORR COEF IS .535

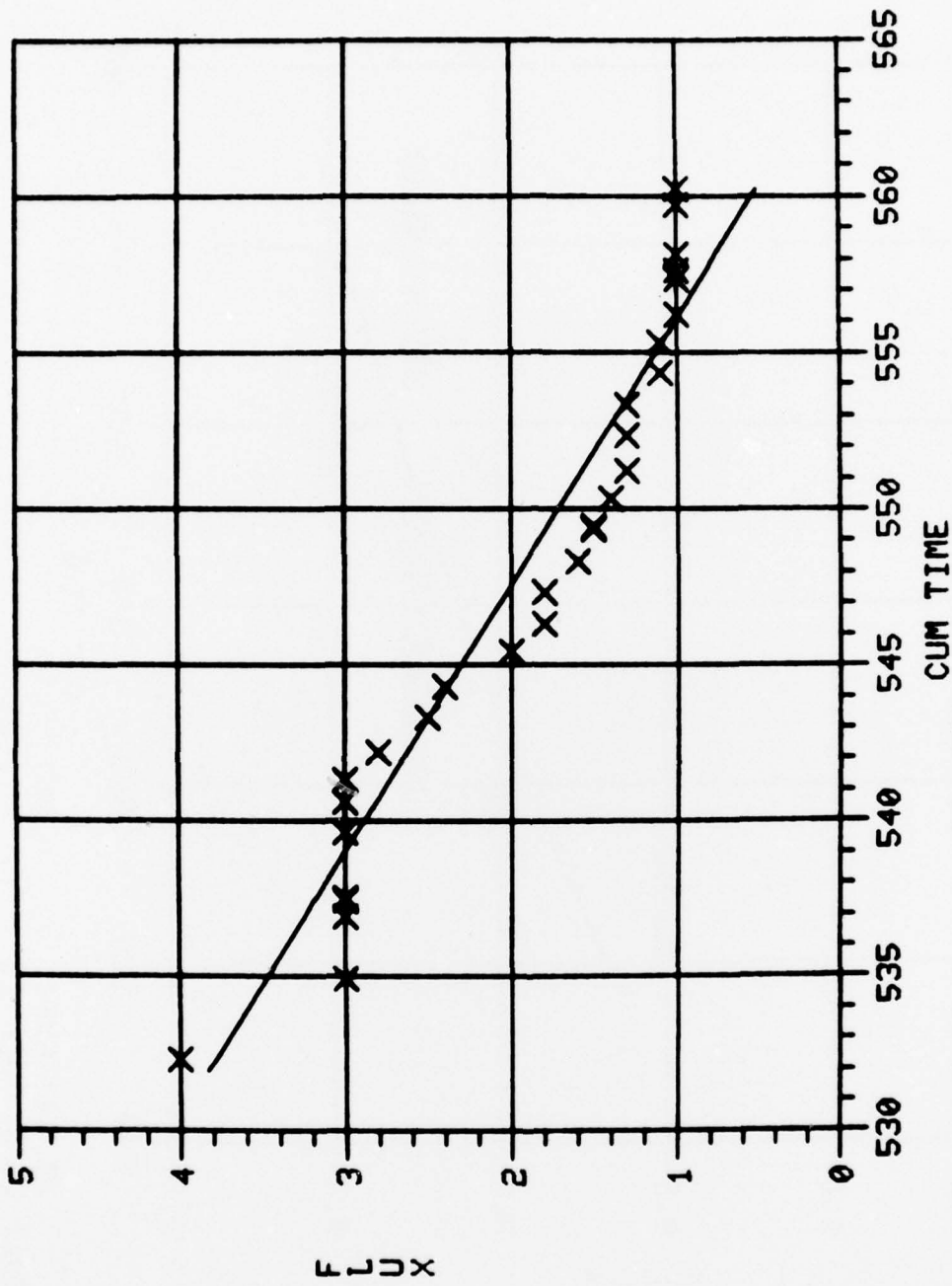

Y = -.12 X + 1.66
 SQ MULT CORR COEF IS 66.1727 .900

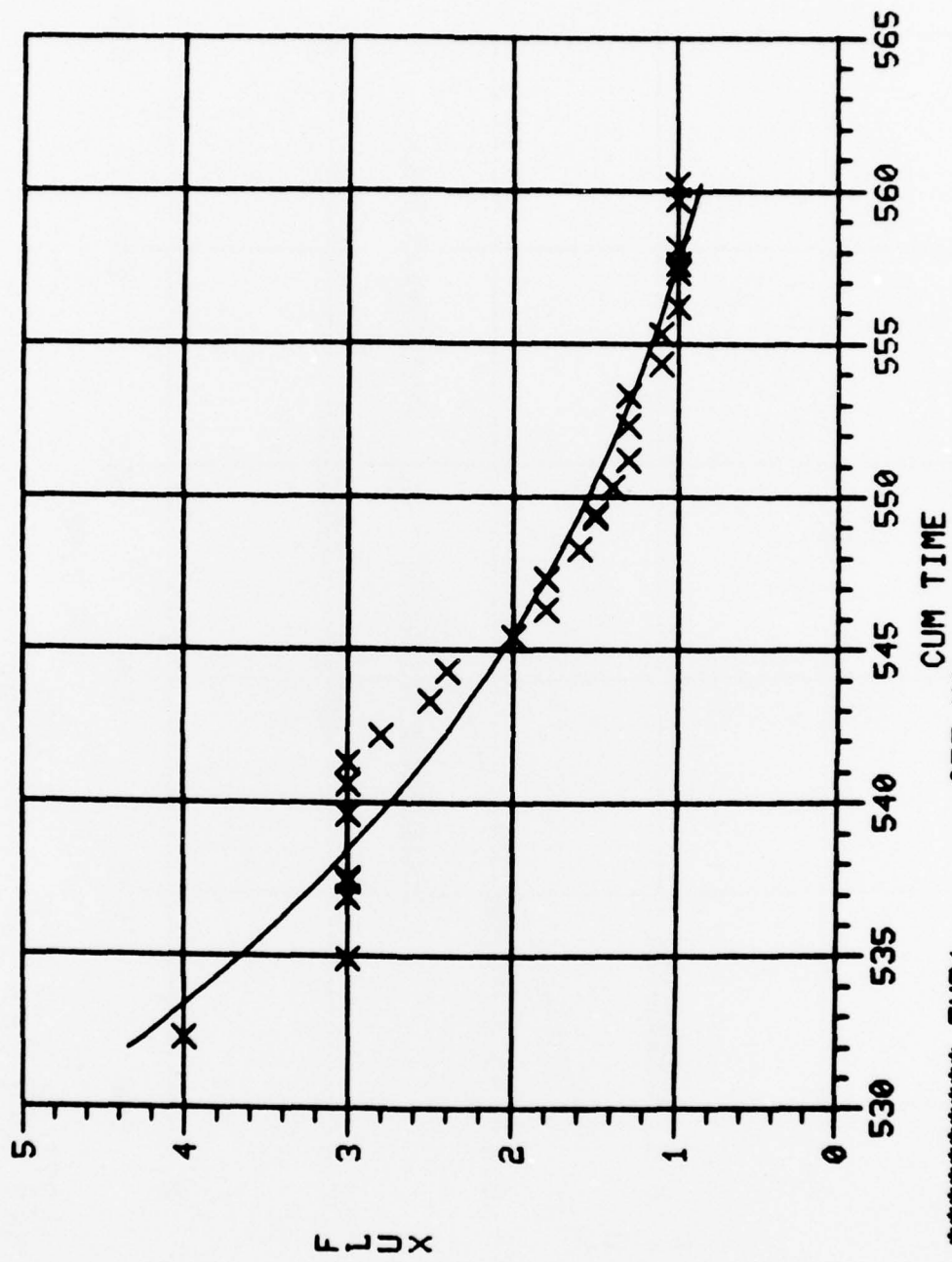

Y - XXXXXXXXXXXX EXP (- .057 X)
 SO MULT CORR COEF IS .963

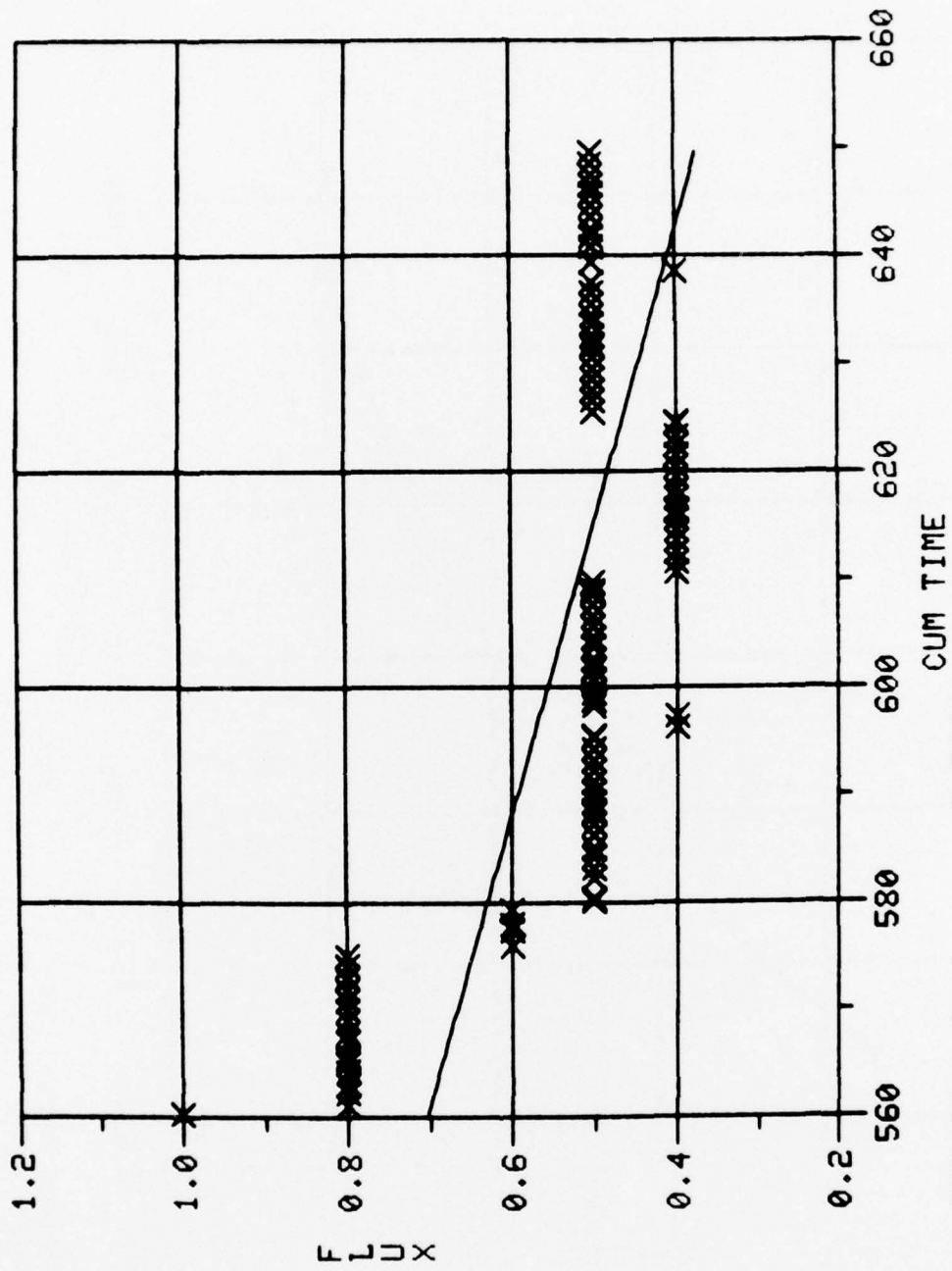

Y = -.37E-02 X ** 1 + 2.7661
 SQ MULT CORR COEF IS .480

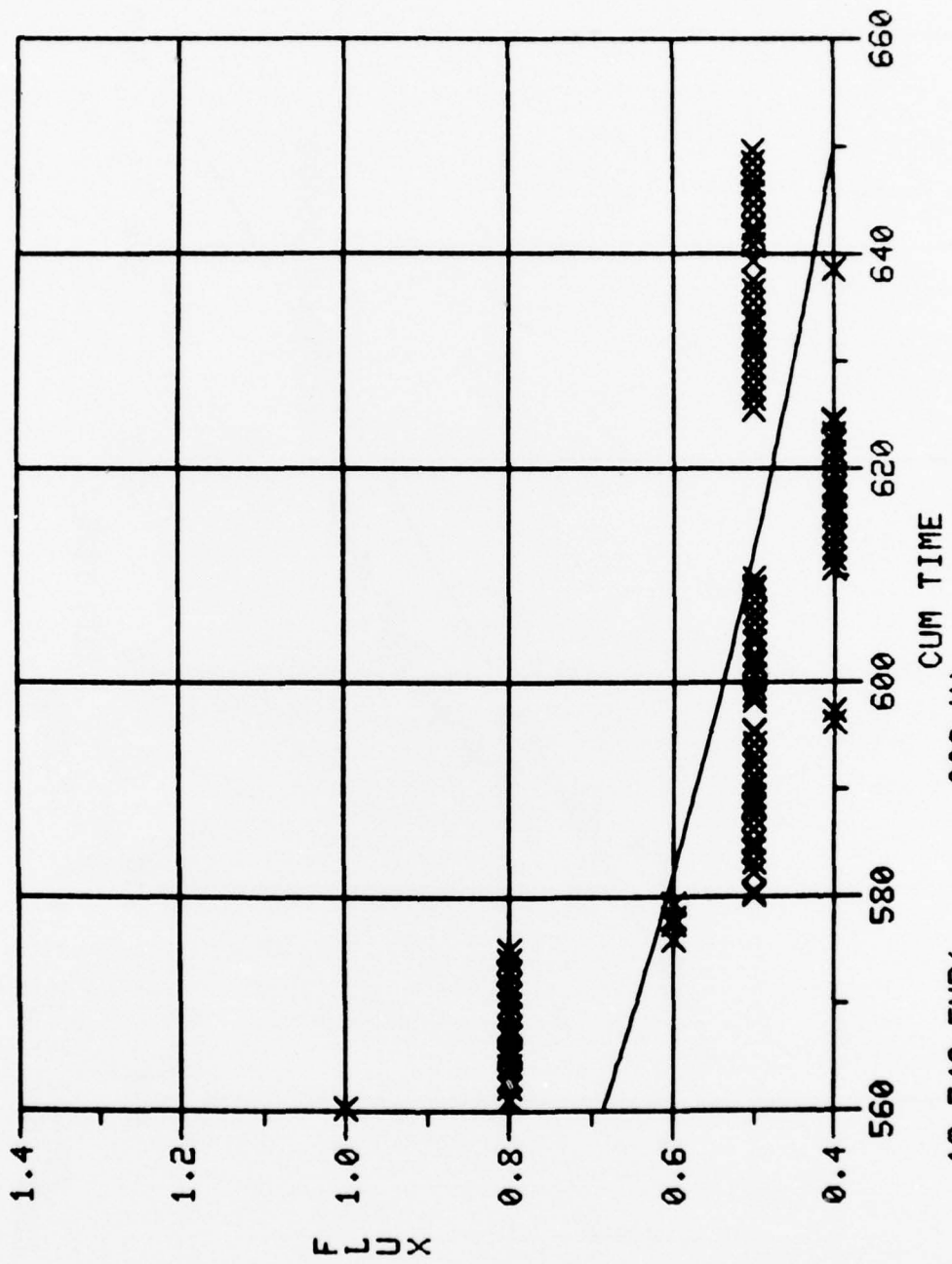

Y = 19.746 EXP(-.006 X)
 SQ MULT CORR COEF IS .463

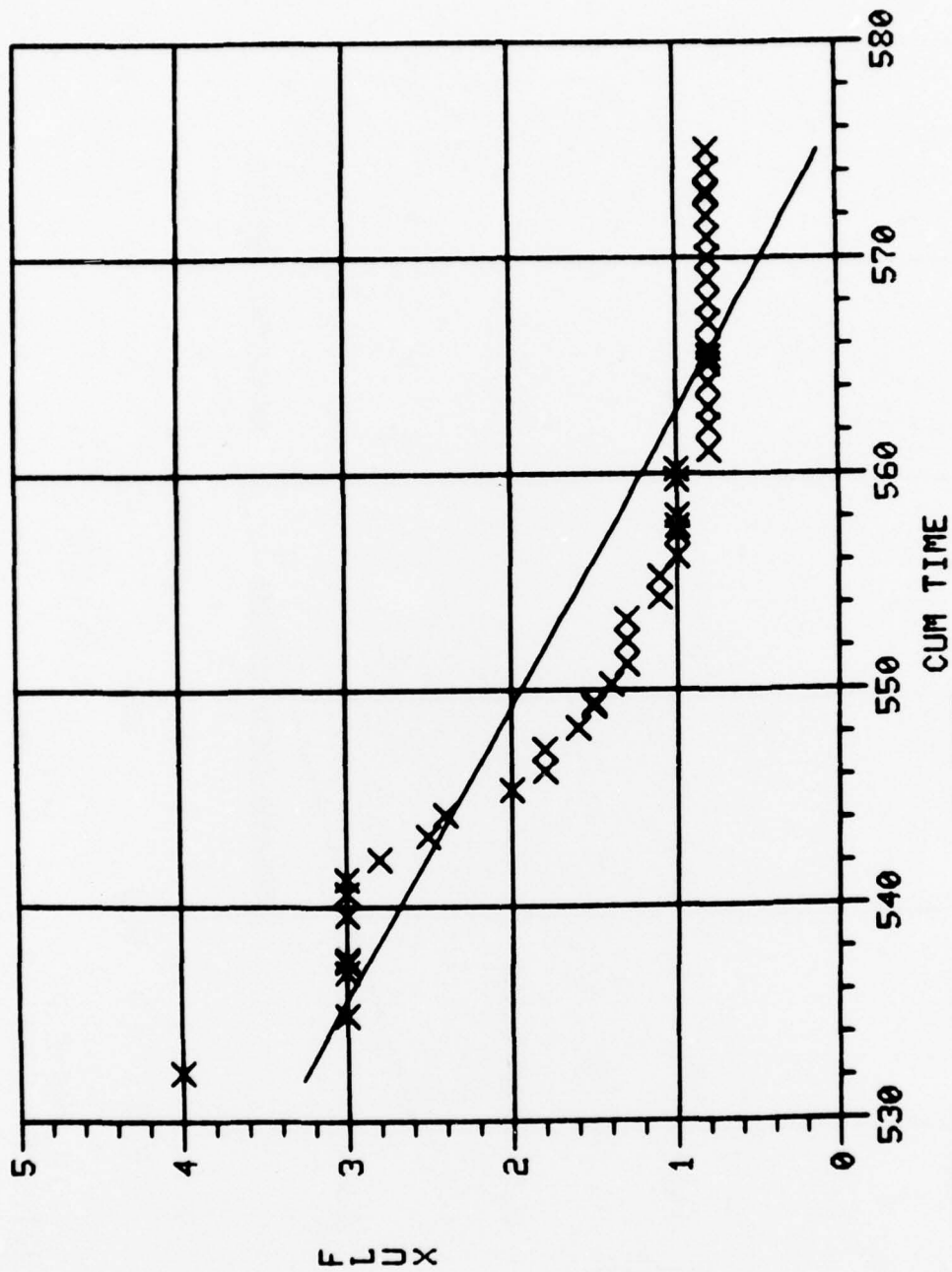

Y = -.73E-01 X + 42.2682
 SQ MULT CORR COEF IS .800

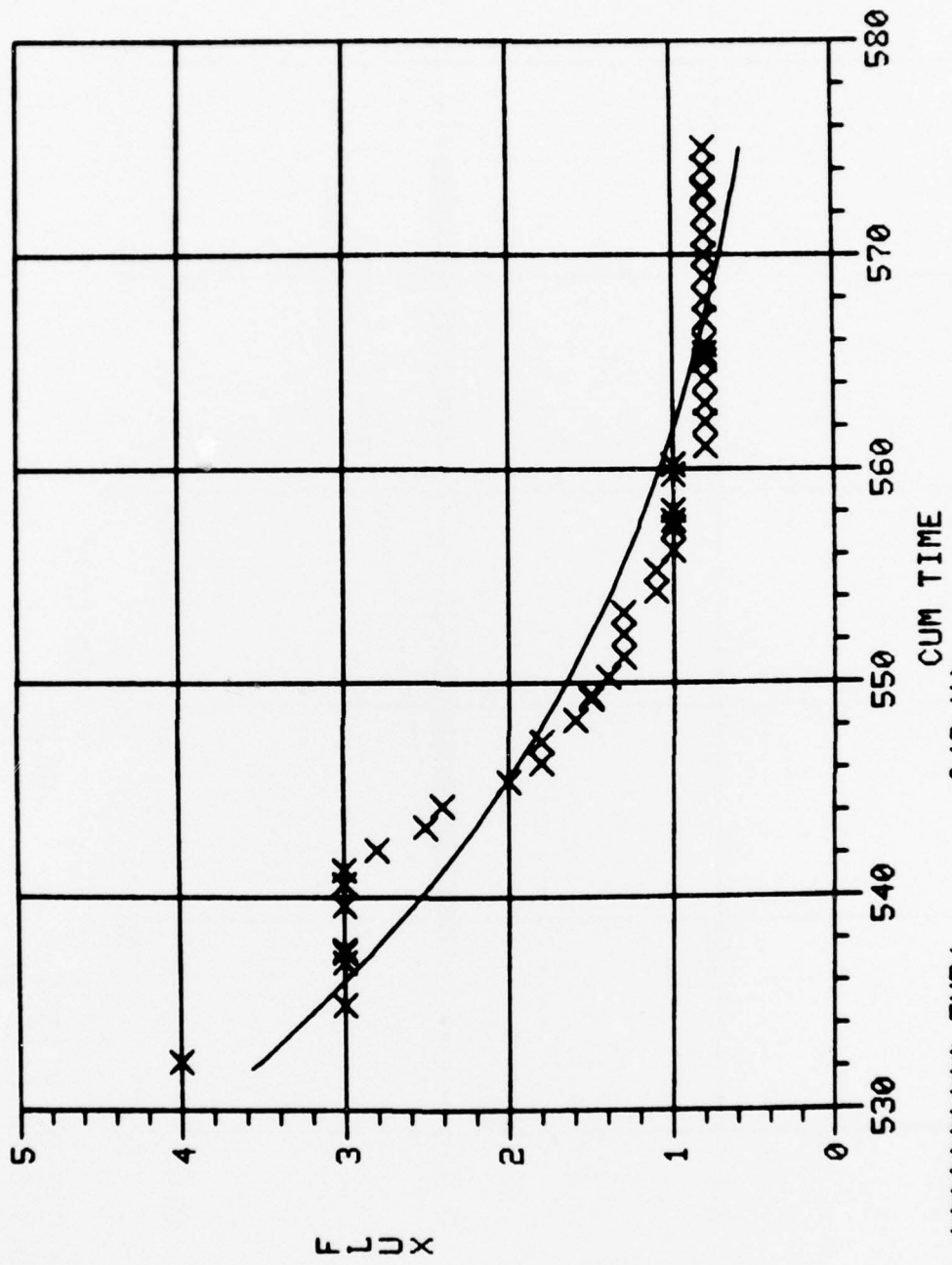

Y - XXXXXXXXXXXX EXP(- .043 X)
 SQ MULT CORR COEF IS .909

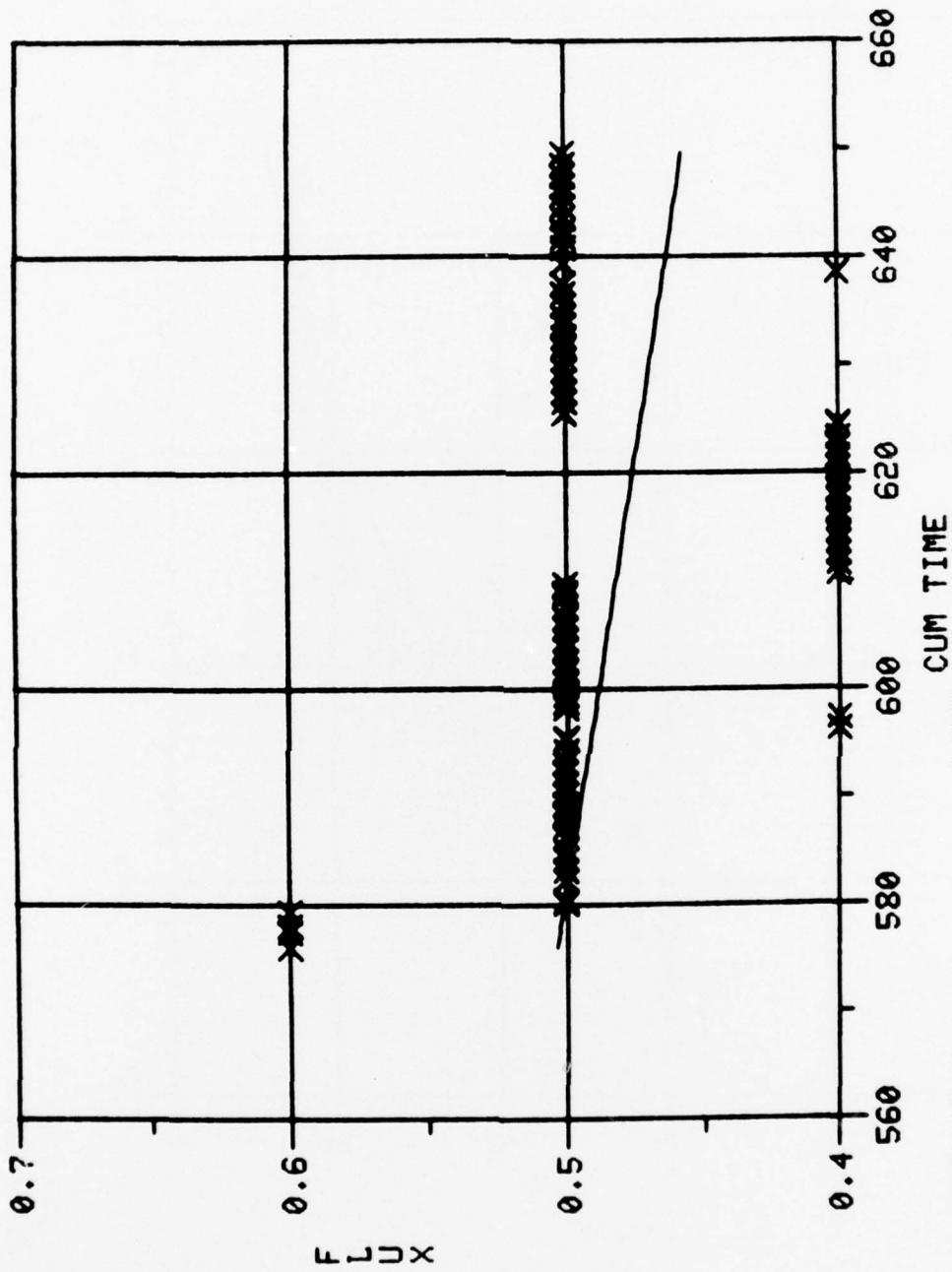

Y = -.63E-03 X XX 1 + .8638
 SQ MULT CORR COEF IS .067

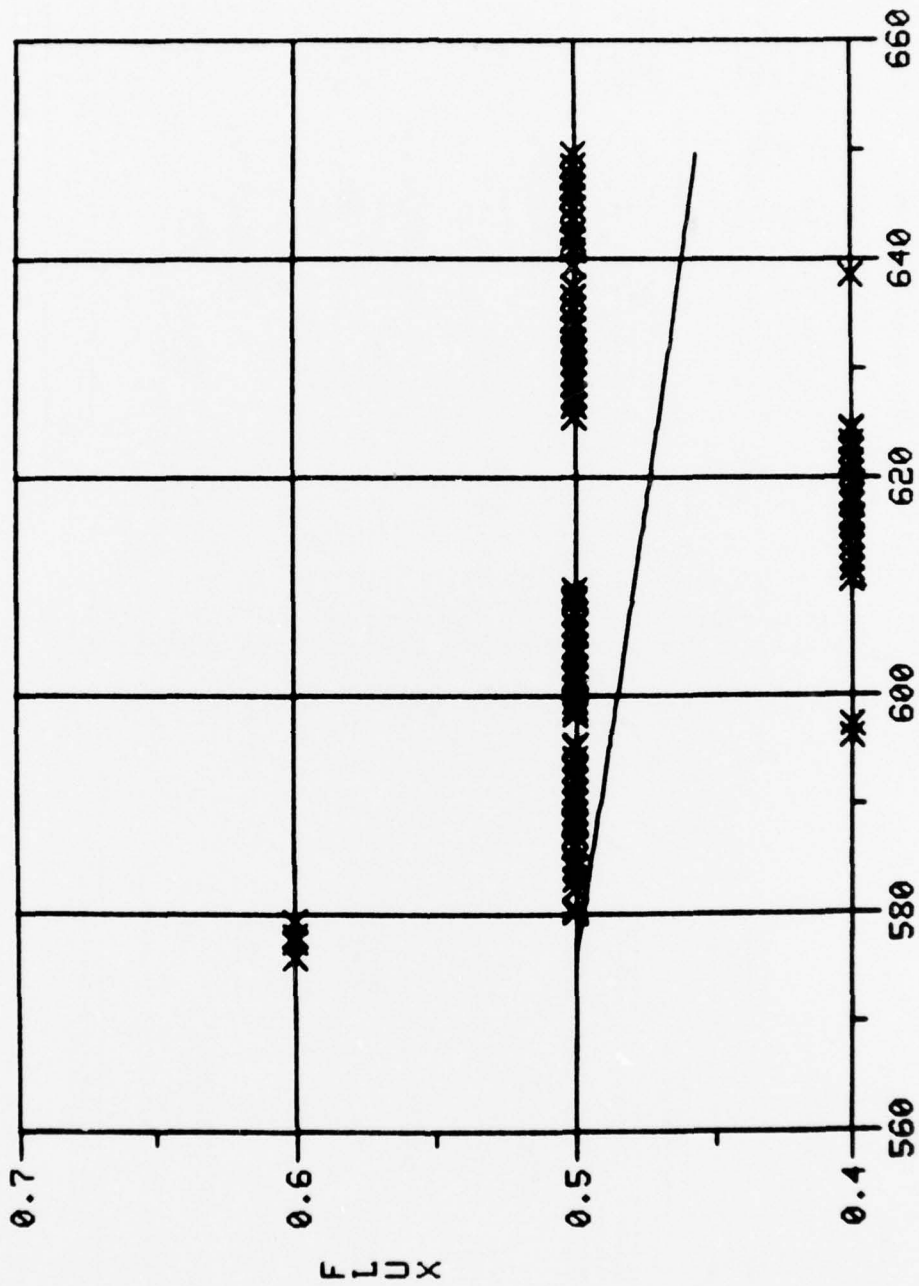

Y = 1.020 EXP(-.001 X)
 SQ MULT CORR COEF IS .057

METRIC CONVERSION FACTORS

Approximate Conversions to Metric Measures				Approximate Conversions from Metric Measures			
Symbol	When You Know	Multiply by	To Find	Symbol	When You Know	Multiply by	To Find
LENGTH							
in	inches	*2.5	centimeters	mm	millimeters	0.04	inches
ft	feet	30	centimeters	cm	centimeters	0.4	inches
yd	yards	0.9	meters	m	meters	3.3	feet
mi	miles	1.6	kilometers	km	kilometers	0.6	miles
AREA							
in ²	square inches	6.5	square centimeters	cm ²	square centimeters	0.16	square inches
ft ²	square feet	0.09	square meters	m ²	square meters	1.2	square yards
yd ²	square yards	0.8	square meters	km ²	square kilometers	0.4	square miles
mi ²	square miles	2.6	square kilometers	ha	hectares (10,000 m ²)	2.5	acres
acres	acres	0.4	hectares				
MASS (weight)							
oz	ounces	28	grams	g	grams	0.035	ounces
lb	pounds	0.45	kilograms	kg	kilograms	2.2	pounds
	short tons (2000 lb)	0.9	tonnes	t	tonnes (1000 kg)	1.1	short tons
VOLUME							
tsp	teaspoons	5	milliliters	ml	milliliters	0.03	fluid ounces
Tbsp	tablespoons	15	milliliters	l	liters	2.1	pints
fl oz	fluid ounces	30	milliliters	qt	quarts	1.06	gallons
c	cups	0.24	liters	gal	gallons	0.26	gallons
pt	pints	0.47	liters	ft ³	cubic feet	35	cubic feet
qt	quarts	0.95	liters	yd ³	cubic yards	1.3	cubic yards
gal	gallons	3.8	liters				
ft ³	cubic feet	0.03	cubic meters				
yd ³	cubic yards	0.76	cubic meters				
TEMPERATURE (exact)							
°F	Fahrenheit temperature	5/9 (after subtracting 32)	Celsius temperature	°C	Celsius temperature	9/5 (then add 32)	Fahrenheit temperature

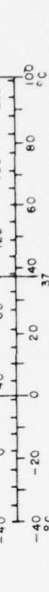
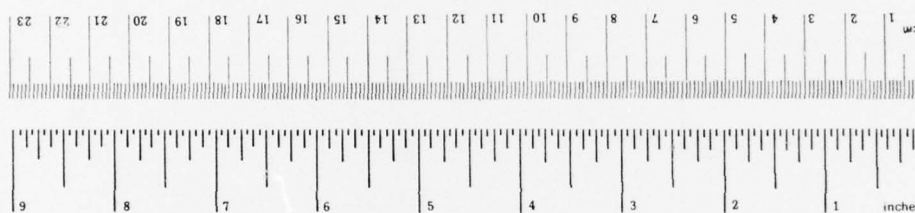

*1 in = 2.54 exactly. For other exact conversions and more detailed tables, see NBS Mon., Publ. 286, Units of Weights and Measures, Price \$2.25, SO Catalog No. C13.10-286.

DISTRIBUTION FOR MERADCOM REPORT 2212

No. Copies	Addressee	No. Copies	Addressee
	Department of Defense	1	Director US Army Materiel Systems Analysis Agency
1	Director, Technical Information Defense Advanced Research Projects Agency 1400 Wilson Blvd Arlington, VA 22209		ATTN: DRXSY-CM Aberdeen Proving Ground, MD 21005
12	Defense Documentation Center Cameron Station Alexandria, VA 22314	1	Director US Army Engineer Waterways Experiment Station ATTN: Chief, Library Branch Tech Information Center Vicksburg, MS 39180
	Department of the Army		
1	Commander, HQ TRADOC ATTN: ATEN-ME Fort Monroe, VA 23651	1	Commander Picatinny Arsenal ATTN: SARPA-TS-S No. 59 Dover, NJ 07801
1	HQDA (DAMA-AOA-M) Washington, DC 20310	1	Commander US Army Troop Support & Aviation Materiel Readiness Command ATTN: DRSTS-KTE 4300 Goodfellow Blvd. St. Louis, MO 63120
1	HQDA (DAEN-RDL) Washington, DC 20314		
1	HQDA (DAEN-MCE-D) Washington, DC 20314	2	Director Petrol & Fld Svc Dept US Army Quartermaster School Fort Lee, VA 23801
1	Chief, Engineer Division DCSLOG ATTN: AFKC-LG-E HQ Sixth US Army Presidio of San Francisco, CA 94129	2	Engineer Representative US Army Standardization Group, UK Box 65, FPO New York 09510
1	Director Army Materials and Mechanics Research Center ATTN: DRXMR-STL Technical Library Watertown, PA 02172	1	Learning Resources Center US Army Engineer School Bldg 270 Fort Belvoir, VA 22060
1	U.S. Army Ballistic Res Labs Technical Library ATTN: DRXBR-LB (Bldg 305) Aberdeen Proving Ground, MD 21005	1	Commandant US Army Command and General Staff College ATTN: ATSW-RI-L Fort Leavenworth, KS 66027
1	Commander Edgewood Arsenal ATTN: SAREA-TS-L Aberdeen Proving Ground, MD 21010	1	Commander and Director USAFESA ATTN: FESA-RTD Fort Belvoir, VA 22060

No. Copies	Addressee	No. Copies	Addressee
	MERADCOM	1	Commander, Naval Facilities Engineering Command Department of the Navy ATTN: Code 032-A 200 Stovall St. Alexandria, VA 22332
1	Commander, DRDME-Z Tech Dir, DRDME-ZT Assoc Tech Dir/R&D, DRDME-ZN Assoc Tech Dir/Engrg & Acq, DRDME-ZE Special Asst/Matl Assess, DRDME-ZG Special Asst/Tech Assess, DRDME-ZK CIRCULATE	1	US Naval Oceanographic Office Library (Code 1600) Washington, DC 20373
1	Chief, Countermine Lab, DRDME-N Chief, Elec Power Lab, DRDME-E Chief, Cam & Topo Lab, DRDME-R Chief, Mar & Br Lab, DRDME-M Chief, Mech & Constr Eqpt Lab, DRDME-H Chief, Counter Intrusion Lab, DRDME-X Director, Product Assur & Testing Directorate, DRDME-T Chief, Material Tech Lab, DRDME-V CIRCULATE	1	Officer-in-Charge (Code L31) Civil Engineering Laboratory Naval Construction Battalion Center Port Hueneme, CA 93043
			Department of the Air Force
		1	HQ USAF/RDPS (Mr. Allan Eaffy) Washington, DC 20330
		1	Mr. William J. Engle Chief, Utilities Branch HQ USAF/PREEU Washington, DC 20332
		1	AFSC/INJ Andrews AFB, MD 20334
10	Energy & Water Resources Lab, DRDME-G	1	AFCEC/XR/21 Tyndall AFB, FL 32401
50	Sanitary Sciences Div, DRDME-GS	1	HQ USAF/PREES ATTN: Mr. Edwin B. Mixon Bolling AFB—Bldg 626 Washington, DC 20332
3	Tech Reports Ofc, DRDME-WP		
3	Security Ofc, DRDME-S		
2	Tech Library, DRDME-WC	1	AFAPL/SFL Wright-Patterson AFB, OH 45433
1	Plans, Programs, & Operations Ofc, DRDME-U	1	Department of Transportation Library, FOB 10A, TAD-494.6 800 Independence Ave., SW Washington, DC 20591
1	Public Affairs Ofc, DRDME-I		
1	Office of Chief Counsel, DRDME-L		
	Department of the Navy		
1	Director, Physics Program (421) Office of Naval Research Arlington, VA 22217	1	Professor Raymond R. Fox School of Engineering and Applied Science The George Washington University Washington, DC 20052
1	Director Naval Research Laboratory ATTN: Code 2627 Washington, DC 20375		