

AD-A043 718

OREGON STATE UNIV CORVALLIS SCHOOL OF OCEANOGRAPHY  
EXPOSURE, NEWSLETTER FOR OCEAN TECHNOLOGISTS, VOLUME 5, NUMBER --ETC(U)  
JUL 77 R MESECAR

F/G 8/10

N00014-67-A-0369-0007

NL

UNCLASSIFIED

1 of 1  
AD  
A043718



END  
DATE  
FILMED  
9 - 77  
DDC

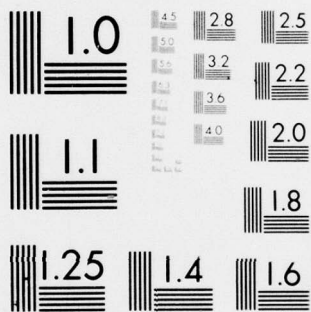

MICROCOPY RESOLUTION TEST CHART  
NATIONAL BUREAU OF STANDARDS-1963-A

12

ADA 043718

# EXPOSURE

vol. 5 no. 3

a newsletter for ocean technologists

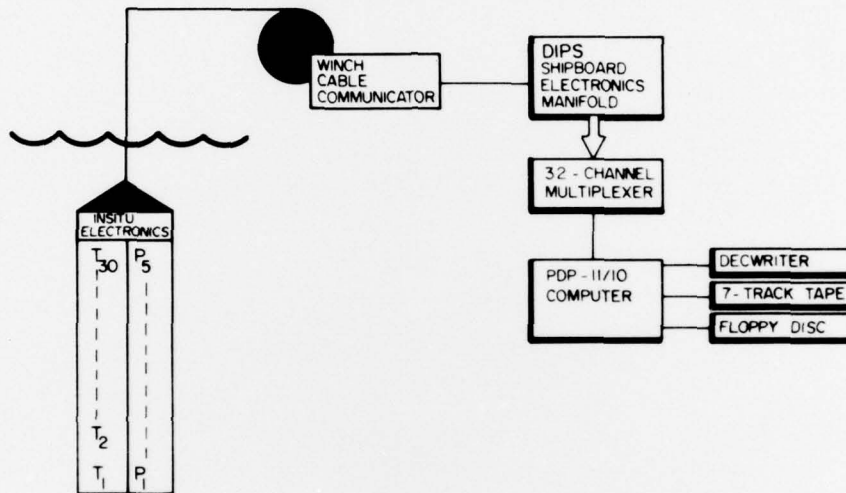

## DISTRIBUTED INSTRUMENTATION PROFILING SYSTEM

The following paper describes a shipboard/towed instrumentation cable for making vertical temperature structure measurements in a program that focuses on the dissipation of temperature fluctuations in the upper 100 meters of the ocean as a function of lateral range. The instrumented cable is implemented with 30 thermistors molded into fairing components and spaced at 1 meter intervals. The system has an accuracy of  $\pm 0.01^\circ\text{C}$  and a resolution of  $0.001^\circ\text{C}$  over a range of 20 degrees Celsius. With a thermistor response less than 0.1 sec and a 5 Hz data rate, a tow speed of 8 knots is possible. All data management is accommodated by a PDP-11/40 shipboard computer.

AU NO. \_\_\_\_\_  
DDC FILE COPY

**DISTRIBUTION STATEMENT A**  
Approved for public release;  
Distribution Unlimited

DDC  
RECEIVED  
SEP 2 1977  
B

July 1977



In the past, the development and application of towed multiple thermistor instrumentation cables has been associated with larger government research laboratories because of the cost, size, special fabrication, number of handling

personnel, and the ship and winch capabilities needed.

This instrumented cable system is patterned after a towed cable concept being developed by the Johns Hopkins

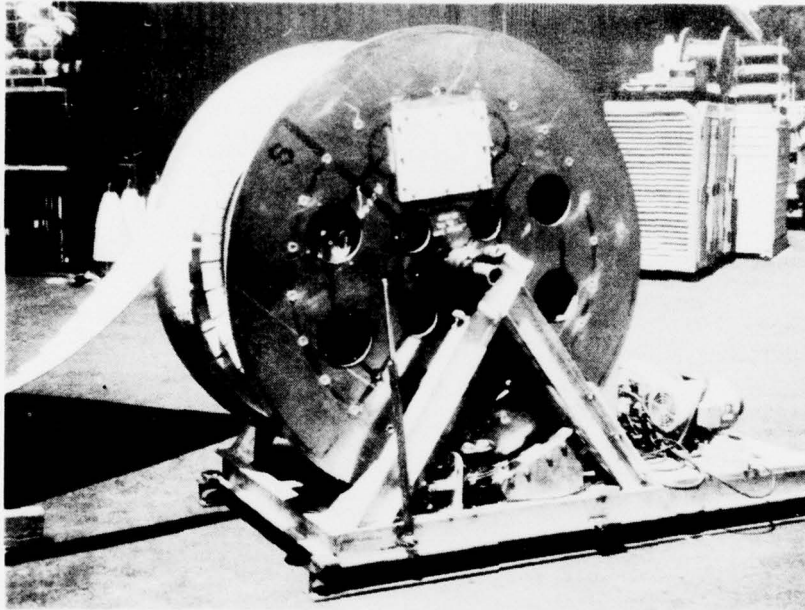

**Figure 1.**

Electrically Powered Aluminum Winch for the 125 m Faired Cable. Total Winch Cable Capacity is 200 m. Winch Base Dimensions are 1.3 m Wide and 2.6 m Long.

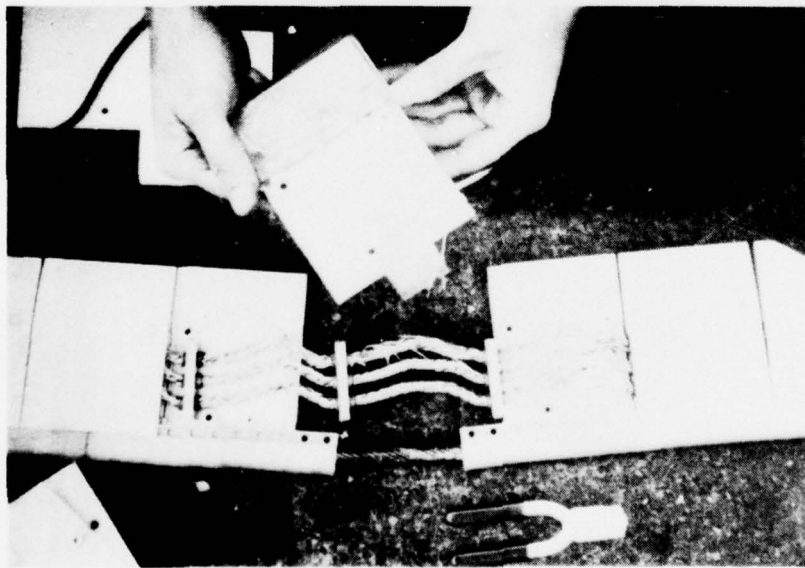

DIPS Sensor Breakout Being Inserted into the Faired Cable.

Applied Physics Laboratory.<sup>1</sup> By leaning on their cable system experience we were able to implement an instrumented cable system that can be used by a 3-4 person research team at a modest cost. This was achieved primarily by the removal of calibration variables dependent upon the thermistor position on the cable, by distributing instrumentation along the cable, and by relaxation of cable requirements.

The towed cable consists of a 150-m-long faired cable with a 460 kg torpedo-shaped, dead-weight depressor at the bottom. On shipboard, the cable is stored in a single layer on a 1.5-m-diameter drum, shown in Figure 1, that is powered to winch the cable in and out at 15 cm per sec.

The modular cable system used by Johns Hopkins is their cable's most attractive feature for the limited facility research group. The instrumentation cable is configured around a model 770T fairing developed by Fathom Oceanology Ltd. The fairing is supplied in three parts: a

flexible polyurethane nosepiece, which is free to swivel about the support cable, and two rigid ABS plastic tail sections that are screw mounted to each other and socketed to the nosepiece. Each fairing section is approximately 10 cm high, 2 cm thick, and 15 cm long.

The fairing section shown in Figure 2 illustrates some of the major benefits of a modular cable system. Listed, they are:

- The thermistor can be molded into a nosepiece section that is kept directed into the streamflow by the fairing tailpiece.
- The fairing allows a separation of the strain member and electrical conductors in the instrumentation cable.
- Electrical cable connections can be made in the field and conveniently protected by the fairing shell.
- Reduced cable drag under tow.

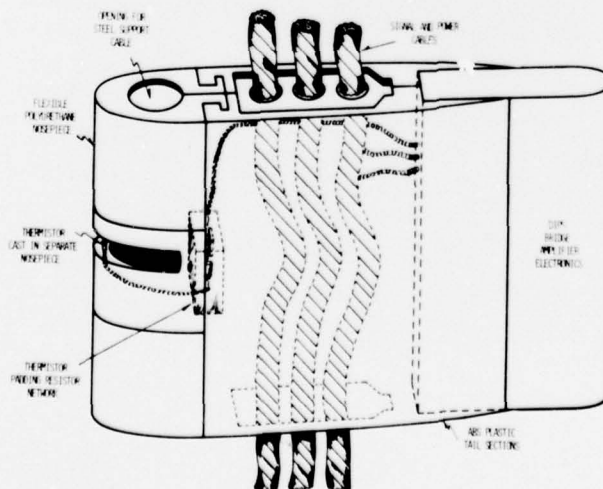

**Figure 2.**

Faired Cable Section with Mounted Thermistor and Electronics Package.

ACCESSION for	
NTIS	White Section <input checked="" type="checkbox"/>
DDC	Buff Section <input type="checkbox"/>
UNANNOUNCED	<input type="checkbox"/>
JUSTIFICATION _____	
BY _____	
DISTRIBUTION/AVAILABILITY CODES	
Dist.	AVAIL. and/or SPECIAL
A	

The goal of this effort was to design a secure interface for the 30 in situ thermistor sensors and six pressure transducers to the shipboard computer system while meeting the performance requirements listed in Table I. Previous analysis of the sensor cable insulation and resistance requirements indicated extreme precautions would be necessary to make a direct thermistor connection to the cable as was done at Johns Hopkins.<sup>2</sup> The burden of maintaining high isolation resistances on 30 thermistor breakout connections was

not acceptable. Also, variations in the calibration of the thermistors, due to the variable cable lengths between thermistor stations, would compromise the desired sensor interchangeability. These limits and requirements dictated distributing some of the instrumentation to the thermistor stations (DIPS).

The final configuration places the thermistor and normalizing resistors in one housing molded to fit as a nosepiece within the chosen fairing (see Figure 2). The normalization

**Table 1. Towed Instrument**

**Cable System Specifications**

Performance

Accuracy:	±.01°C
Range:	0-20°C
Resolution:	±.001°C
Time Response:	<.1 sec
Data Rate:	5 Hz
Filter Location:	2.5 Hz 2 pole
Tow Speed:	3-8 knots

System Requirements

Interchangeability:	Thermistors ±2%
	Bridge Amplifiers ±1%
	Receiver Amplifiers ±.01% trimmed
Drift:	Long term (30 days) <.01°C
	Short term <.001°C
Cable:	Complete interchangeability
	Isolation Required > 200 k Ω operational
Number:	30 temperature
	6 pressure
Common Mode Rejection:	> 80 dB (.1 mV @ 1V pickup)

resistors are used to bring the entire population of thermistors to within  $\pm 2\%$  for direct interchangeability without requiring a broadening of operating range to include widely divergent resistance samples. These nosepieces are assembled to the fairing onto which has been molded a bridge amplifier. The amplifier/fairing/thermistor assembly can then be integrated into the faired cable and connections made to a power source pair and an output line pair. The connections made here are much less sensitive to leakage degradation than a direct connection would be and the long wire run to the surface has a more relaxed series/shunt resistance tolerance requirement. Through the use of very low offset amplifiers (Precision Monolithics OP-07) and precision resistors (Vishay Networks), the amplifier was designed to have less than  $\pm .1\%$  tolerance in its zero and  $\pm 1\%$  tolerance in its gain parameters (adjustable by resistor selection) to limit the required dynamic range due to component tolerance bands. At the top end of the cable there is a  $\pm 3\%$  worst-case tolerance band which must be incorporated into the dynamic

range of the digitization system; 94% of this range is a useable data span. This error band should not be confused with the calibration requirement of  $\pm .01^\circ\text{C}$ . The amplifiers and thermistors have associated with them calibration parameters for use in data reduction, but they are interchangeable without system retrim.

With a low impedance drive to the line, it is possible to sense the line level with a very high impedance instrumentation amplifier with a common mode rejection ratio (CMRR) of greater than 100 dB which rejects line pickup and also eliminates the effect of conductor resistance. A ground reference for the amplifiers can be obtained from the power-drive system and true differential sensing is possible without a source imbalance. With control of the worst-case error band, a high degree of data content (94% of full scale) is maintained on the line allowing maximum transfer of resolution in the bridge amplifier through the line and its noise to the surface data system. Resolution better than  $.0005^\circ\text{C}$  has been apparent in field trials with a bandwidth of 5 Hz (see Figure 3).

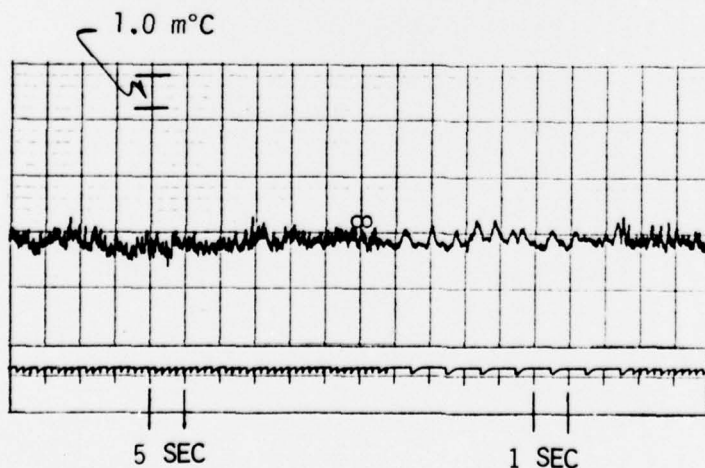

**Figure  
3.**

Typical DIPS  
Channel  
Temperature  
Resolution  
Versus Time.

The ability to read the system zero and a known output point is a well established data security check procedure. The bridge amplifiers are fitted with two reed switches which, when enabled by a magnetic actuator, substitute a null resistor or a full scale calibrated resistance for the thermistor. This provides, upon demand, verification of the function of all parts of the system except the sensor itself.

A user demanding  $.001^{\circ}\text{C}$  resolution in a  $20^{\circ}\text{C}$  range must be aware of the range of the digitizer required. In

this system, this problem has resolved itself by recognizing that only  $5\text{--}6^{\circ}\text{C}$  temperature range is expected within any given data set and  $2\text{--}3^{\circ}\text{C}$  range is more typical. As shown in Figure 4, a 12-bit conversion of the data channels can convert this range into  $.001$  increments, but a system must be provided to accurately offset the entire bank of amplifiers.

The instrumentation amplifiers are fitted with a unit gain offset terminal which is driven by an offset system with a reference accuracy of

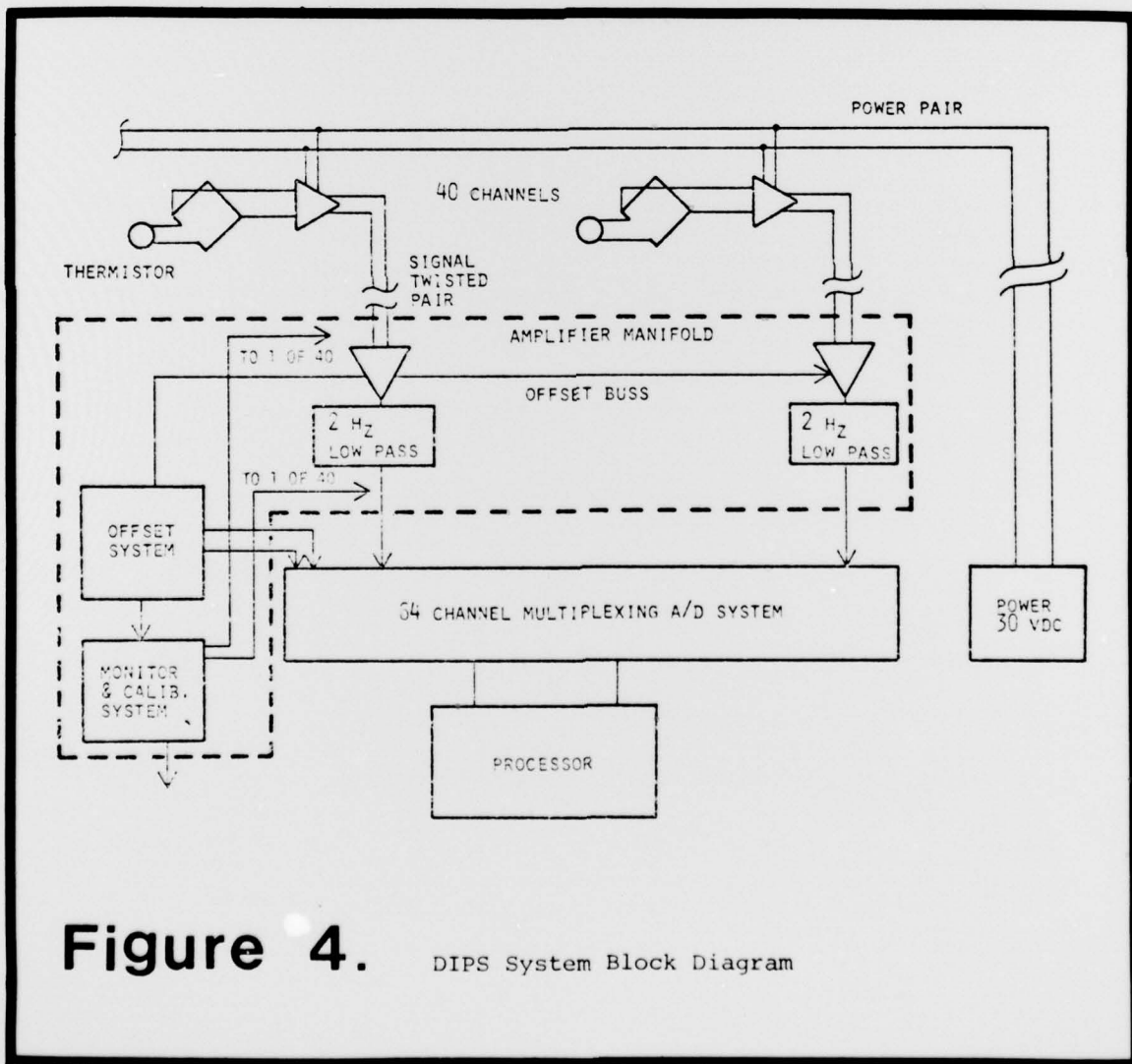

**Figure 4.** DIPS System Block Diagram

5 p/m and an overall resetability of 100 p/m. This was accomplished with a combination of switchable fixed offset and high resolution vernier scales. The actual output from the switched range and the vernier range is independently digitized to 12 bits, which gives a resolution of one part in 40,000 in the value of the offset in use at the time of data collection. A two-pole state variable filter is built on each amplifier for use as an anti-alias filter.

The overall performance of the system meets the design criteria in Table I. In addition, due to the interchangeability of components, it is possible to transfer to the end user the level of technology required for field maintenance of the system.

## References:

<sup>1</sup>F. F. Mobley *et al.* "A New Thermistor Chain for Underwater Temperature Measurement." Oceans 76 Conference, September 13-15, 1976, Washington, D.C.

<sup>2</sup>Sippican Corporation, Marine, Massachusetts. (Restricted Report). "Feasibility Study for a Towed Thermistor Chain."

## FOR FURTHER INFORMATION, CONTACT:

Rod Mesecar/Frank Evans  
School of Oceanography  
Oregon State University  
Corvallis, OR 97331

Telephone: (503) 754-2206



*Rod Mesecar is Head of the Technical Planning & Development Group, School of Oceanography, at Oregon State University. He has BS, MS, and EE degrees in electrical engineering and a PhD in physical oceanography from OSU. Since 1965, his*

*interest has been in applying engineering technology to all disciplines of oceanography.*



*Frank Evans received his education in electronics from the University of California at Berkeley. He has worked on high security multiplexed alarm systems, biomedical instrumentation, and physiological*

*optics. He is a member of the Technical Planning & Development Group at OSU and is currently working on multiplexed data systems for oceanography.*

# DESIGN AND OPERATION OF VARIABLE-HEIGHT PLANKTON SLED

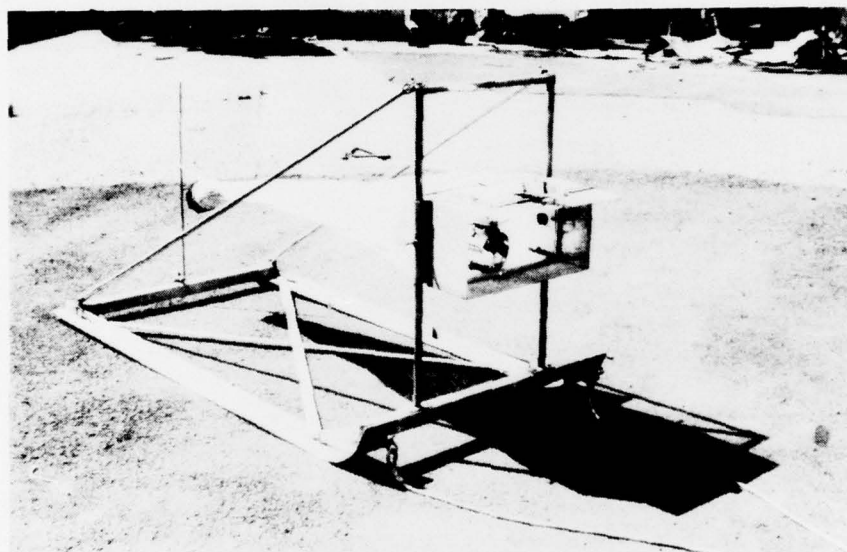

Figure 1. Epibenthic Sampler with Door Open

While conducting a biological baseline investigation of Youngs Bay, Oregon, we encountered a common problem: the inability of conventional plankton nets (a one-meter net and a Clarke-Bumpus sampler had been used) to effectively and discretely collect plankton and swimming benthic forms in water close to the substrate. To make such collections, we have constructed an epibenthic plankton sampler, which is a half-meter net mounted on a sled (Figure 1). The bottom of the net opening may be positioned from 15 to 71 cm above the substrate surface and the mouth has an opening/closing device.

A number of near-bottom samplers have been described (Bossanyi, 1951; Dovel, 1964; Frolander and Pratt, 1962; Macer, 1967; Wickstead, 1953). Generally, they lack the combination of properties useful to us: adjustable net height, with the ability to sample very close to the substrate; a closing device; net mouth preceding sled runners to prevent collection of disturbed sediment; broad runners to avoid sinking into very soft substrates; and sturdy construction to withstand possible encounters with sunken logs and similar hazards.

The sled is patterned in part after the sampler constructed by Dovel (1964). His device was basically a

1-meter net mounted on a set of cross-braced aluminum runners. This light frame was collapsible and easily transported, but experience showed that additional weight was needed for the net to consistently sample the epibenthic region. The net had no closing device, with the result that the net sampled during descent and ascent, which was 17 to 20 percent of the tow period.

The essential dimensions of the present sampler are illustrated in Figure 2. The overall size of the sled is similar to Dovel's; however, the runners are wider and the sled is constructed of Type 304 stainless steel, which adds considerably to the weight (approximately 78 kg) and

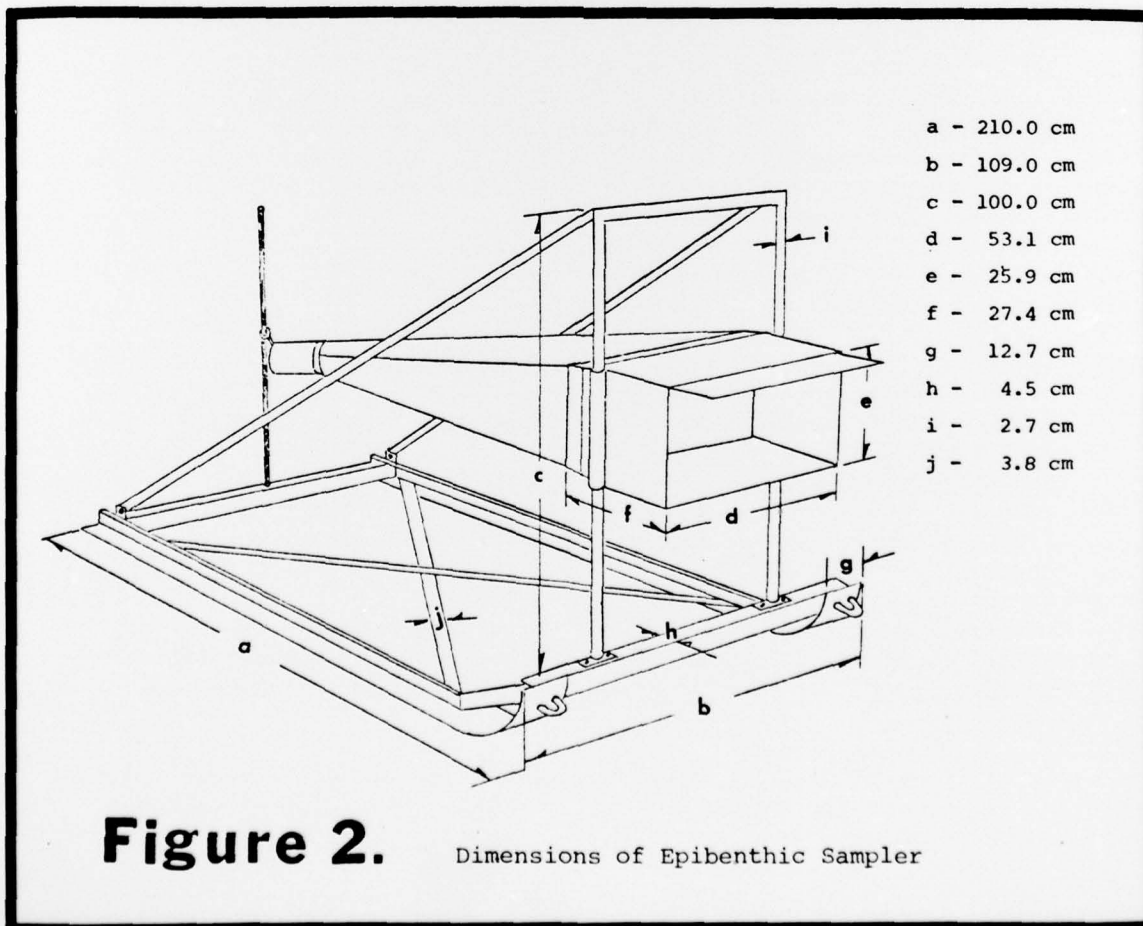

sturdiness of the sampler. Only the mouth door is of light-weight aluminum, to facilitate opening under spring tension. The box (net mouth) may be positioned at any height on the uprights.

The joints are welded except for those connecting the tubular uprights and rear braces. These are bolted in place--as could be other joints where further collapsibility is required. The bridle connects to the leading end of the runners, although a bridle connection higher on the frame would be preferable to reduce substrate disturbance.

The closing device (Figure 1) utilizes pins, hand lines, and springs. A strong spring is used to open the door, while a weak spring (and water flow) close the door. A long pin slides in front of the door and holds it closed against the tension of the strong spring, while a second smaller pin provides a removable connection between this spring and the door. Both pins are attached to light nylon hand lines.

The sampler was tested in a clear-water lake where it was towed by a 24-ft dory. Divers reported that the sled "skied" upright to the bottom (60 to 120 m) where it travelled in a stable fashion at normal towing speeds (1 to 2 knots). The front of the sled lifted momentarily from the substrate if the boat moved ahead from a stop, but otherwise remained on the substrate.

The opening/closing door is controlled by springs and pins which are pulled using nylon lines that run from the sled to the ship. Pin #1 is

pulled (and retrieved) while the vessel is momentarily stopped. This allows the door to spring open without interference from the water flow. At the end of the run, pin #2 is pulled which allows the door to be closed by water flow and tension from a second, lighter spring. A "stop" on the wire running from the door to the first spring prevents the door from closing until the second pin is pulled.

Despite the heaviness of the sampler and the use of lines for opening and closing the door, no major problems were encountered in obtaining samples 15 to 71 cm above the soft muds and fine sands of the substrate.

A drawback to the sampler is the pin lines, which restrict sampling to shallow, reasonably quiet waters.

## References:

- Bossanyi, J. 1951. "An Apparatus for the Collection of Plankton in the Immediate Vicinity of the Sea Bottom." *Journal of the Marine Biol. Assoc.* 30:265-270
- Dovel, William L. 1964. "An Approach to Sampling Estuarine Macroplankton." *Ches. Sci.* 5:77-90
- Frolander, H. F. and Ivan Pratt. 1962. "A Bottom Skimmer." *Limn. and Ocean.* 7:104-106

REPORT DOCUMENTATION PAGE		READ INSTRUCTIONS BEFORE COMPLETING FORM
1. REPORT NUMBER Vol. 5, No. 3	2. GOVT ACCESSION NO. A 2 4040586	3. RECIPIENT'S CATALOG NUMBER
4. TITLE (and Subtitle) EXPOSURE Newsletter for ocean technologists. Volume 5. Number 3.	5. TYPE OF REPORT & PERIOD COVERED 7 technical report.	6. PERFORMING ORG. REPORT NUMBER
7. AUTHOR(s) 10 Dr. Roderick Hesezar (Ed.)	8. CONTRACT OR GRANT NUMBER(s) 15 N00014-67-A-0369-0007	9. PERFORMING ORGANIZATION NAME AND ADDRESS School of Oceanography Oregon State University Corvallis, OR 97331
11. CONTROLLING OFFICE NAME AND ADDRESS NORDA, NSTL Bay St. Louis, MS 39520 Attn: Code 410	12. REPORT DATE 11 July 1977	10. PROGRAM ELEMENT, PROJECT, TASK AREA & WORK UNIT NUMBERS NR 083-102
14. MONITORING AGENCY NAME & ADDRESS (if different from Controlling Office)	13. NUMBER OF PAGES 72 pages (12 + 3 p.)	15. SECURITY CLASS. (of this report) (U)
16. DISTRIBUTION STATEMENT (of this Report) Approved for public release; distribution unlimited		15a. DECLASSIFICATION/DOWNGRADING SCHEDULE
17. DISTRIBUTION STATEMENT (of the abstract entered in Block 20, if different from Report)		
18. SUPPLEMENTARY NOTES Published every two months by the School of Oceanography, Oregon State University, Corvallis, OR 97331		
19. KEY WORDS (Continue on reverse side if necessary and identify by block number) Ocean technology; instrumentation.		
20. ABSTRACT (Continue on reverse side if necessary and identify by block number) Distributed Instrumentation Profiling System, Design and Operation of Variable-Height Plankton Sled.		

Macer, C. T. 1967. "A New Bottom-  
Plankton Sampler." J. Cons. Perm.  
Int. Explor. Mor. 31:158-163.

Wickstead, J. 1953. "A New Apparatus  
for the Collection of Bottom  
Plankton." J. Mar-Biol. Assoc.  
U.K. 32:347-355.

FOR FURTHER INFORMATION, CONTACT:

Duane Highley/Robert Holton/  
Michael Christian  
School of Oceanography  
Oregon State University  
Corvallis, OR 97331

Telephone: (503) 754-4172

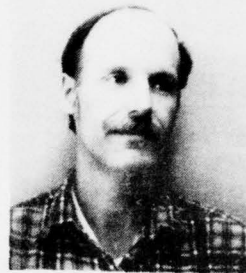

*Duane L. Higley is a Research  
Assistant in Oceanography at  
Oregon State University where  
he works primarily in estuarine  
ecology. He received BS and  
MS degrees in Fishery Biology  
from OSU.*

*Robert L. Holton is an Assistant  
Professor of Oceanography at  
OSU. His main interest is in  
estuarine research and pollution-  
related research studies. He  
presently is Executive Director  
of the Oregon Estuarine Research  
Council.*

*Michael R. Christian currently  
is a member of the U.S. Navy.  
He received an Associate of Arts  
degree in Oceanography and  
Biology in 1973 from Clatsop  
Community College, Astoria, Oregon.*

TABLE OF CONTENTS

Page	Article	Author
1	Distributed Instrumentation Profiling System	Mesecar/ Evans
8	Design and Operation of Variable-Height Plankton Sled	Higley/ Holton/ Christian

Dr. Rod Mesecar, Editor  
EXPOSURE  
School of Oceanography  
Oregon State University  
Corvallis, Oregon 97331

**FIRST CLASS MAIL**

**Help Wanted**

**BELIEVE IT OR NOT**

School will be starting soon. You're a few \$\$\$ short. We can help. Call for details and apply.

**TEMPORARY UNLIMITED**

Call for details and apply.

NO FEE TO APPLICANTS

**LOCAL CARE FACILITY** Now accepting applications for a 40 hour generic aid program training class. Completion will be given upon successful completion of the class. You must be interested in helping the sick and elderly and have good work understanding systems and experience in school consultation with interest in mental health. Experience and

Call for details and apply.

Call for details and apply.

Call for details and apply.

Animal Care  
(One full-time position)  
(One part-time position)  
Shift work \$32-\$398 per month (full-time) \$42-\$59 per month (part-time). City is seeking someone to enforce provisions of the City's Animal Control Ordinance. Persons selected must have working knowledge of animal care and handling and be able to communicate effectively with animal owners, transport pickup and impound animals without incurring personal injury. Must possess a valid State of Oregon Driver's License. Apply at the Personnel Office 501 W. Madison, by Friday, August 1st.

**PLANNING TECHNICIAN**  
Starting salary \$715 per month. 2 years of college level study, preferably in public administration or related field. Assist in the planning and development of the city's long range plan and reviewing the plan. Position is a full-time position. Applicant must possess or have working knowledge of quantitative methods, technical report writing and local governmental or public administration. Application deadline August 1st. This is a permanent position. Send resume to Personnel Division.

**EXPOSURE**