

AD-A044 052

ARMY ELECTRONICS COMMAND FORT MONMOUTH N J  
CATHODE LIMITED OPERATION OF TRANSVERSELY EXCITED CARBON DIOXID--ETC(U)  
JUL 77 A PAPAYOANOU  
ECOM-4510

F/G 20/5

UNCLASSIFIED

NL

| OF |  
AD  
A044 052



END  
DATE  
FILMED  
9-77  
DDC

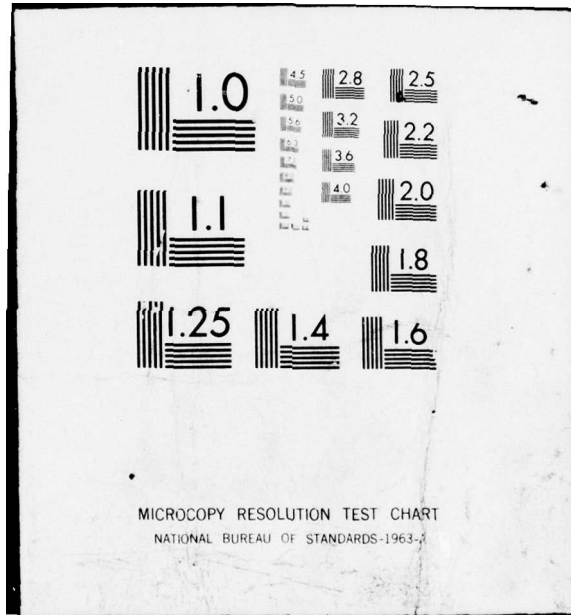

MICROCOPY RESOLUTION TEST CHART  
NATIONAL BUREAU OF STANDARDS-1963-A



12

AD A 0440529

Research and Development Technical Report

ECOM-4510

CATHODE LIMITED OPERATION OF TRANSVERSELY EXCITED CARBON DIOXIDE CHANNEL WAVEGUIDE LASER.

A. Papayoanou

Combat Surveillance & Target Acquisition Laboratory

17161101A91A

July 1977

50

24p.

DISTRIBUTION STATEMENT  
Approved for public release;  
distribution unlimited.

DDC  
RECEIVED  
SEP 13 1977  
B

DDC FILE COPY

ECOM

US ARMY ELECTRONICS COMMAND FORT MONMOUTH, NEW JERSEY 07703

037620

LB

## NOTICES

### Disclaimers

The findings in this report are not to be construed as an official Department of the Army position, unless so designated by other authorized documents.

The citation of trade names and names of manufacturers in this report is not to be construed as official Government indorsement or approval of commercial products or services referenced herein.

### Disposition

Destroy this report when it is no longer needed. Do not return it to the originator.

UNCLASSIFIED

SECURITY CLASSIFICATION OF THIS PAGE (When Data Entered)

REPORT DOCUMENTATION PAGE		READ INSTRUCTIONS BEFORE COMPLETING FORM
1. REPORT NUMBER <b>ECOM-4510</b>	2. GOVT ACCESSION NO.	3. RECIPIENT'S CATALOG NUMBER
4. TITLE (and Subtitle) <b>CATHODE LIMITED OPERATION OF TRANSVERSELY EXCITED CARBON DIOXIDE CHANNEL WAVEGUIDE LASER</b>		5. TYPE OF REPORT & PERIOD COVERED
		6. PERFORMING ORG. REPORT NUMBER
7. AUTHOR(s) A. Papayoanou		8. CONTRACT OR GRANT NUMBER(s)
9. PERFORMING ORGANIZATION NAME AND ADDRESS US Army Electronics Command ATTN: DRSEL-CT-L Fort Monmouth, New Jersey 07703		10. PROGRAM ELEMENT, PROJECT, TASK AREA & WORK UNIT NUMBERS 1T1 61101 A91A 50 081
11. CONTROLLING OFFICE NAME AND ADDRESS US Army Electronics Command ATTN: DRSEL-CT-L Fort Monmouth, New Jersey 07703		12. REPORT DATE <b>July 1977</b>
14. MONITORING AGENCY NAME & ADDRESS (if different from Controlling Office) US Army Electronics Command Combat Surveillance & Target Acquisition Laboratory Fort Monmouth, New Jersey 07703		13. NUMBER OF PAGES 20
		15. SECURITY CLASS. (of this report) Unclassified
		15a. DECLASSIFICATION/DOWNGRADING SCHEDULE
16. DISTRIBUTION STATEMENT (of this Report) Distribution Unlimited, Approved for Public Release		
17. DISTRIBUTION STATEMENT (of the abstract entered in Block 20, if different from Report)		
18. SUPPLEMENTARY NOTES		
19. KEY WORDS (Continue on reverse side if necessary and identify by block number) Carbon Dioxide Laser, Transversely Excited, Channel Waveguide, CW, Pulsed, Glow Discharges, Cathode Fall, Lifetime Limitation, Malter Effect		
20. ABSTRACT (Continue on reverse side if necessary and identify by block number) (U) The discharge, gain and oscillator characteristics of transversely excited CO <sub>2</sub> gas mixes was investigated under pulsed and CW conditions. A 1.6 mm square channel having a segmented upper electrode structure and a solid copper electrode with dielectric sidewalls formed the discharge chamber. Resistive loading of the individual discharge segments precluded arcing and insured glow discharges. However, the discharges were not wall confined except at pressures below 100 Torr, thereby reducing wall cooling and complete volumetric		

DD FORM 1 JAN 73 1473 EDITION OF 1 NOV 65 IS OBSOLETE

UNCLASSIFIED

SECURITY CLASSIFICATION OF THIS PAGE (When Data Entered)

could  
UNCLASSIFIED

SECURITY CLASSIFICATION OF THIS PAGE(When Data Entered)

excitation. For low pressures a large fraction of the energy was deposited in the cathode fall region. At higher pressures the luminous glow discharge column narrowed and the ratio of the power dissipated in the cathode fall region decreased. However, the total power and power densities deposited in this region increased. The high electric fields and gas temperatures in this region dissociate and ionize molecules thereby limiting sealed-off lifetimes. Diffusion of heat into the adjoining gas creates turbulence and limits the gain.

Detailed analysis of the negative aspects of the cathode fall region and non-uniform volume excitation suggests those areas where improvement is most essential. Certain improvements can be obtained by revising the construction of these devices. It remains essential, however, to limit the negative aspects of the cathode fall region and the Malter effect is suggested as one possible means of accomplishing this.

ACCESSION for	
NTIS	White Section <input checked="" type="checkbox"/>
BDC	Buff Section <input type="checkbox"/>
UNANNOUNCED	<input type="checkbox"/>
JUSTIFICATION	
BY	
DISTRIBUTION/AVAILABILITY CODES	
Dist. Code and/or SPECIAL	
A	

UNCLASSIFIED

SECURITY CLASSIFICATION OF THIS PAGE(When Data Entered)

## TABLE OF CONTENTS

	<u>Page</u>
I. INTRODUCTION	1
II. EXPERIMENTAL ARRANGEMENT	2
a. Construction of TE Channel Laser	2
b. Pulsing Circuits	2
c. Gain Measurement Setup	7
III. MEASUREMENTS AND OBSERVATIONS	7
a. CW Discharges	7
b. Pulsed Discharges	9
IV. ANALYSIS	13
V. CONCLUSION	17
VI. REFERENCES	19

### FIGURES

- |  |   |
|--|---|
| 1. Components of TE discharge laser showing the electrodes and sidewalls. The solid electrode was made of polished copper and the striped electrode of alternating slabs of boron nitride and graphite. The sidewalls with their slotted construction are shown. Placement of copper wires in slots is indicated although in final construction each wire was resistively loaded with 100 k $\Omega$ . | 3 |
| 2. SCR controlled pulsed discharge circuit for TE laser.   | 4 |
| 3. Typical voltage waveform of RC charging circuit. Voltage is across the capacitors. Vertical sensitivity is 1000 V/cm with the 0 representing the zero voltage level. Time base 50 $\mu$ s/cm; Pressure 250 Torr; Mix ratio He:CO <sub>2</sub> :N <sub>2</sub> = 55:28:17.   | 5 |
| 4. Typical voltage, current traces on a dual beam scope. Trigger of sweep initiated by gate pulse to SCR. Time response of voltage and current probes was much faster than rise and fall times detected.   | 6 |
| 5. Gain setup used. Dotted curves on the chopped probe signal indicate gain pulses which occur just after the current excitation pulses.   | 8 |

6. Total pulsed gain in 15 cm length versus pressure for different gas flows and mix ratios.  $\tau_D$  represents the dwell time of the gas in the discharge region. Open cycle flow. Cathode water cooled to  $22^\circ \pm 2^\circ\text{C}$ . Pulse repetition rate was 5 kHz. 10
7. Average power versus pressure in open cycle flow using a premix gas He:CO<sub>2</sub>:N<sub>2</sub> in ratio of 80:12:8. Optimum voltages for each pressure were used. Mirror reflectivities are noted in legend. 11
8. Superposition of 3 single oscilloscope traces separated in time between 30 seconds and 1 minute. Sweep is triggered by the gate pulse to the SCR. Top trace is that of discharge current. Bottom traces reveal laser pulses at different times. Different times of occurrence and peak laser heights due to thermal length variation of Fabry-Perot cavity mirrors separated by lucite box. Time base 0.5  $\mu\text{s}/\text{cm}$ .
9. Typical V-I curves of glow discharges as parameters of pressure where  $P_1 < P_2 < P_3$ . The desired line is determined by the optimum E/P value for the CO<sub>2</sub> laser mix. 15

## I. INTRODUCTION

A transversely excited channel waveguide laser was first operated with CO<sub>2</sub> gas mixes by Smith, Maloney and Wood.<sup>1</sup> Using a pulsing technique investigated for transversely excited atmospheric (TEA) CO<sub>2</sub> lasers by Smith and DeMaria<sup>2</sup> and Johnson<sup>3</sup> it was found that a 1 mm square channel laser could be operated at pressures to 1 atmosphere. This laser was characterized by easily achieved high repetition rate laser pulsing, gain switched spikes at higher pressures and apparent insensitivity, due to waveguiding of walls, to beam wander.

The advantage of operating a compact CO<sub>2</sub> TEA laser in the TEM<sub>00</sub> mode with narrow (approximately 100 ns) pulsewidths, at tens of kilohertz repetition rates, moderate peak powers and low operating voltages is inevitably interesting for radar and beacon applications. Consequently, a series of experiments has been carried out to determine the potential of such a laser. The experimental setup allowed the investigation of CW as well as pulsed discharges.

As a result of these investigations, it is concluded that a small channel CO<sub>2</sub> TEA discharge cannot be efficiently operated as a laser unless new techniques are employed. The limitation inherent in such devices is the large energy deposited by the discharge into the cathode fall region. Not only is this energy useless in the excitation process, it also has a highly negative aspect. The extremely high energy densities in the cathode fall region produce localized gas heating which diffuses through the excitation volume thereby limiting gain and creating turbulence. The high fields (and temperatures) in the cathode fall region dissociate the molecules and create large ion densities thereby limiting sealed off lifetimes.

Preionization, which allows a more uniform and efficient energy input and specially devised cathodes which limit the cathode voltage drop, are techniques which might be useful in overcoming the known difficulties. Such techniques have been used by Wood, et al.,<sup>4,5</sup> although their interests centered on maintaining a quasi CW output. Unfortunately, preionization techniques which do not interfere with the waveguiding action add a degree of complexity to these devices which limits their attractiveness. Cathode structures devised to limit cathode potentials by use of the Malter effect<sup>6</sup> are not entirely understood and, by themselves, require additional study.

---

1. P. W. Smith, P. J. Maloney and O. R. Wood II, Appl. Phys. Lett 23, 524 (1973).

2. D. C. Smith, A. J. DeMaria, J. Appl. Phys. 41, 5212 (1970).

3. D. C. Johnson, IEEE J. Quant. Elect., QE-7, 185 (1971).

4. O. R. Wood II, P. W. Smith, C. R. Adams and P. J. Maloney, Appl. Phys. Lett., 27, 539 (1975).

5. P. W. Smith, C. R. Adams, P. J. Maloney and O. R. Wood II, Optics Commun., 16, 50 (1976).

6. E. Nasser, Fundamentals of Gaseous Ionization and Plasma Electronics, Wiley-Interscience, New York, 1971.

The following discussion summarizes the experimental techniques and results obtained. Analysis of these results then allows us to elaborate on the statements made above.

## II. EXPERIMENTAL ARRANGEMENT

### a. Construction of TE Channel Laser

The anode electrode was formed by joining alternating slabs of boron nitride (BN) and graphite (Gr) together and machining the electrode surface. Graphite conducting slabs were chosen because of the ease and accuracy with which a smooth surface could be attained with BN. These materials are relatively soft and easy to machine together thereby preventing digging into the BN by metallic chips. The "POCO" brand graphite used is very dense and machines to a high smoothness mostly free of the obvious volume occlusions found in most graphites. The surface quality of this electrode structure was maintained smooth and flat to between 0.0001 and 0.0002 inches or about 2 to 5  $\mu$ m. The width of each slab was 1.6 mm. The overall length of this electrode, which includes 46 Gr slabs, was 15 cm.

The cathode was made of OHF copper whose surface was highly polished. It was cooled by circulating water in a closed cycle. This served to keep the cathode floating until the Silicon Controlled Rectifier (SCR) switched it to ground potential. The side walls made of carefully machined BN had small slots (0.005 inch or 0.13 mm) where they met the electrodes. The slotted region of one sidewall was along the cathode surface while the opposite sidewall was slotted on the side where it met the anode electrode. The transverse flow thus moved diagonally across the channel. Figure 1 shows the various machined pieces prior to final assembly. Additionally, fine copper wires are shown in some of the sidewall slots. In the final design, such wires were installed to line up in one-to-one fashion with each Gr slab. Each wire was resistively loaded with a 100K resistor and the tip of the wire was 0.15 mm above the cathode surface and 1 mm from the entrance to the waveguide chamber. These wires were added to investigate the effect of simple preionization schemes when the flow was from cathode to anode.

### b. Pulsing Circuits

A reliable fast pulse discharge was attained using a circuit as shown in Figure 2 below. As stated earlier, this was previously used<sup>1-3</sup> with TEA lasers. It should be noted that the use of the SCR thyristor as a switch allowed overvoltaged discharges at high repetition rates (to 10 kHz) with small jitter. Operation of transversely excited (TE) and axial discharges as relaxation oscillators, as discussed by Rudko,<sup>7</sup> have considerable breakdown jitter.

---

7. R. I. Rudko, IEEE J. Quant. Electron, QE-10, 497 (1974).

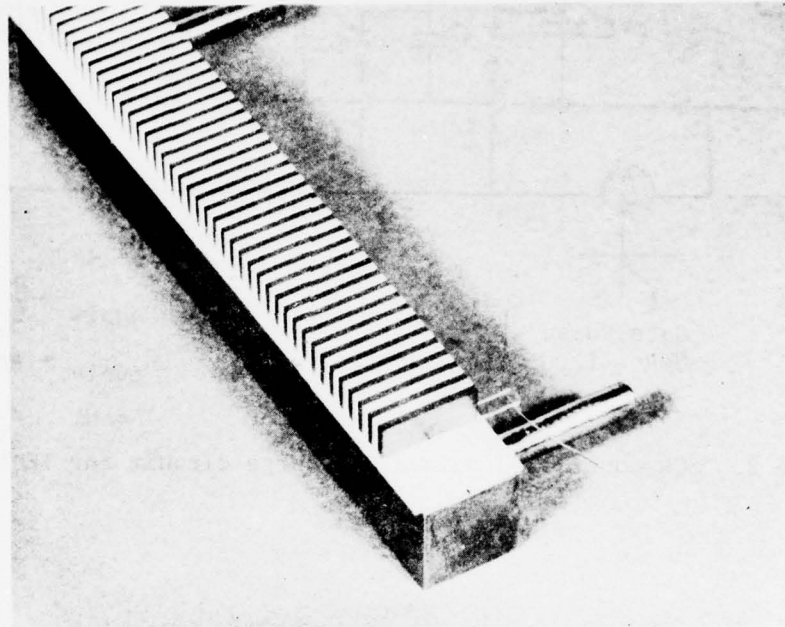

Figure 1. Components of TE discharge laser showing the electrodes and sidewalls. The solid electrode was made of polished copper and the striped electrode of alternating slabs of boron nitride and graphite. The sidewalls with their slotted construction are shown. Placement of copper wires in slots is indicated although in final construction each wire was resistively loaded with 100 kilo-ohm.

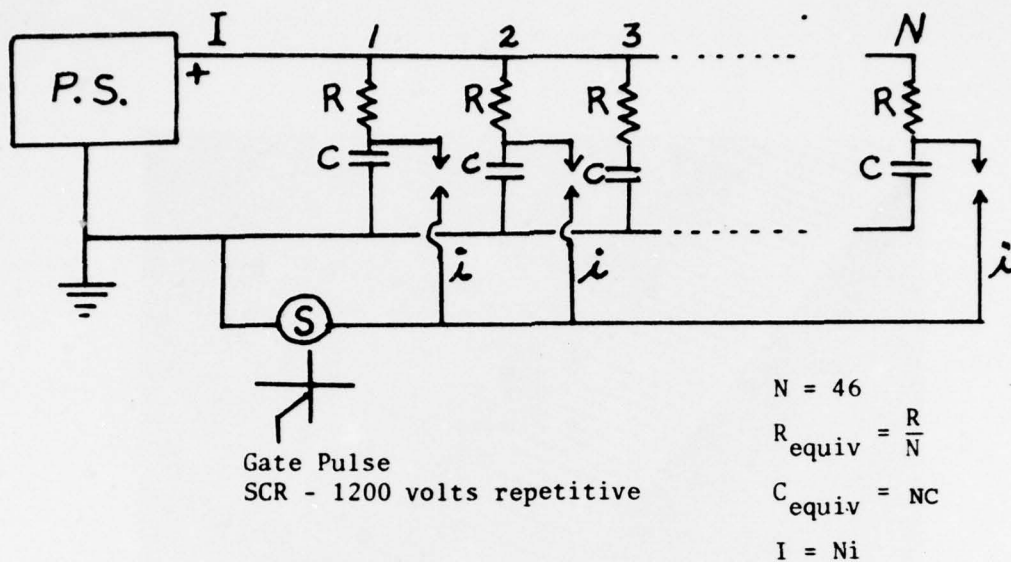

Figure 2. SCR controlled pulsed discharge circuit for TE laser.

$$V_b(t) = V_o + (V_s - V_o)(1 - e^{-t/c}) \quad (1)$$

$V_b$  = breakdown or firing voltage,

$V_o$  = voltage below which discharge terminates,

$V_s$  = power supply voltage,

$t = \tau$  is time required to reach firing voltage  $V_b$ .

Repetition frequency

$$f = \frac{1}{\tau} = \frac{1}{RC \ln \left( \frac{V_s - V_o}{V_s - V_b} \right)} \quad (2)$$

$$i(t) \approx C \frac{dV}{dt} = \frac{V_s - V_o}{R} e^{-t/RC} \quad (3)$$

$$i_{\text{AVG}} = \frac{C(V_s - V_o)}{\tau} (1 - e^{-\tau/RC}) \quad (4)$$

Typically,  $\tau > 2 RC$ ,

$$R = 1.5 \times 10^6 \Omega,$$

$$C = 55 \times 10^{-12} \text{ f.}$$

For the typically used value of  $\tau = 200 \text{ us}$ , we find  $V_b = 0.91 V_s + 0.09 V_o$

$$V_b = 0.91 V_s + 0.09 V_o \approx 0.93 V_s.$$

Figure 3 shows a waveform of the repetitive charging discharging process across an individual capacitor. Careful study of the pulse to pulse electrical discharge jitter indicates that, at the pressures and voltages used, there is less than 60 ns breakdown jitter. Figure 4 is a sketch showing typical voltage, current waveforms as studied on a dual beam oscilloscope. The bracketed lines indicate the temporal range of occurrence of the discharge event. As in Figure 3 the voltage waveform is measured across a typical capacitor to ground.

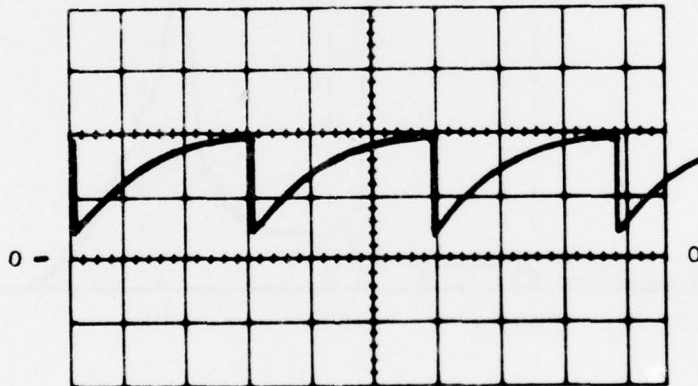

figure 3. Typical voltage waveform of RC charging circuit. Voltage is across the capacitors. Vertical sensitivity is 1000 V/cm with the 0 representing the zero voltage level. Time base 50 us/cm; Pressure 250 Torr; Mix ratio He:CO<sub>2</sub>:N<sub>2</sub> = 55:28:17.

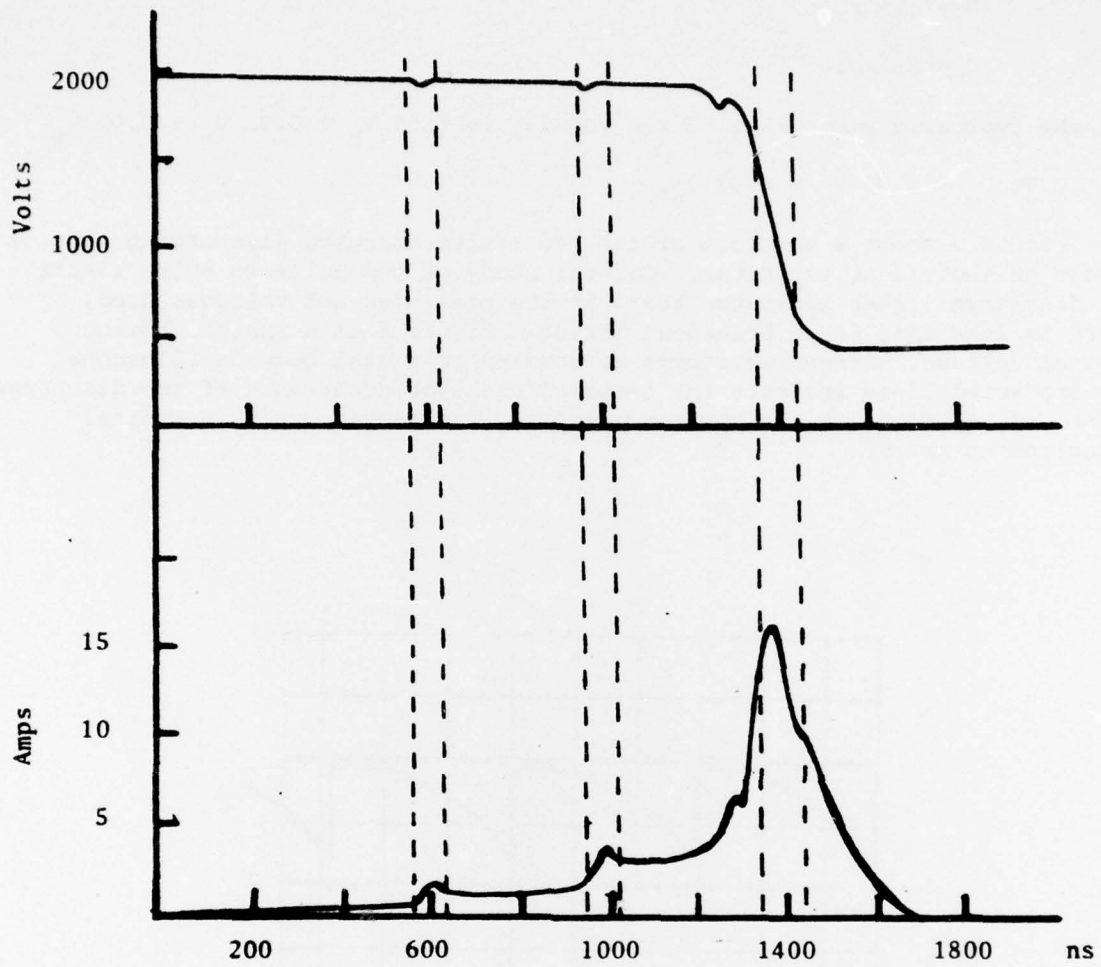

Figure 4. Typical voltage, current traces on a dual beam scope. Trigger of sweep initiated by gate pulse to SCR. Time response of voltage and current probes was much faster than rise and fall times detected.

From Figure 4 it is seen that the energy deposition requires 300 ns although the maximum energy is deposited within 200 ns. It is noted that at early times, 550 to 1200 ns, after the gate pulse the discharge is characterized by high voltage, low current (somewhat sporadic), across the gap. This is indicative of glow discharges. For times between 1400 and 1600 ns, the discharge is characterized by lower voltages and larger currents as is more indicative of streamers. Typically, peak currents per graphite slab were between 250 and 500 mA in the pressure range 100 to 250 Torr. Average currents are about half those values. The energy input per pulse is given by  $E = \frac{1}{2} NC (V_b^2 - V_o^2)$ .

It was found that  $V_o$  was typically between 450 and 500 volts. Thus, for applicable values,  $E$  between 4 and 6 millijoules were deposited per pulse. Since this energy was deposited within 250 ns, the average input power was approximately 20 kilowatts.

Returning to Figure 2, it is obvious that the discharge can be run in the CW mode if the capacitor connection to ground is removed and the cathode side is directly connected to ground. Thus, a momentary exchange of leads allowed the discharge to be run pulsed or CW.

#### c. Gain Measurement Setup

Figure 5 shows the setup used to determine gain. The probe CO<sub>2</sub> laser used was a stable BN channel laser similar to the one previously reported.<sup>8</sup> It remained stable on the P(20) 10.59  $\mu$ m line but was not adjusted for line center. Pulse gain measurements used a technique similar to that reported by Jacobs.<sup>9</sup> The photovoltaic Mercury Cadmium Telluride (HgCdTe) detector used had a frequency response, unbiased, greater than 10 MHz. The combined rise time of the scope and detector was 12.5 ns which was much faster than the characteristic times observed for the gain or laser pulses. For CW measurements the 600 Hz chopper was replaced by a 13 Hz chopper and thermopile detector both of which were part of a frequency and phase sensitive detection scheme.

### III. MEASUREMENTS AND OBSERVATIONS

#### a. CW Discharges

Each anode resistor had a 1.5 M $\Omega$  ballast resistor. A previous study<sup>10</sup> found that such large values were required to maintain a stable CW TE discharge over a wide pressure range.

Visual observation of the discharges revealed a conical shaped luminous region with anode as vertex and cathode as base. Increasing the pressure beyond 100 to 200 Torr, depending on the mix ratio, resulted in the discharge contracting radially in a well known manner.<sup>11</sup> This process appears to be

8. A. Papayoanou, IEEE J. Quant. Electron, QE-12, 27 (1977).

9. R. R. Jacobs, Rev. Sci. Inst., 44, 1146 (1973).

10. A. Fujisawa and A. Papayoanou, ECOM Tech Rpt 4326, May 1975.

11. R. Papoular, "Electrical Phenomena in Gases," American Elsevier Publishing Company, New York, NY, 1965 (Page 140).

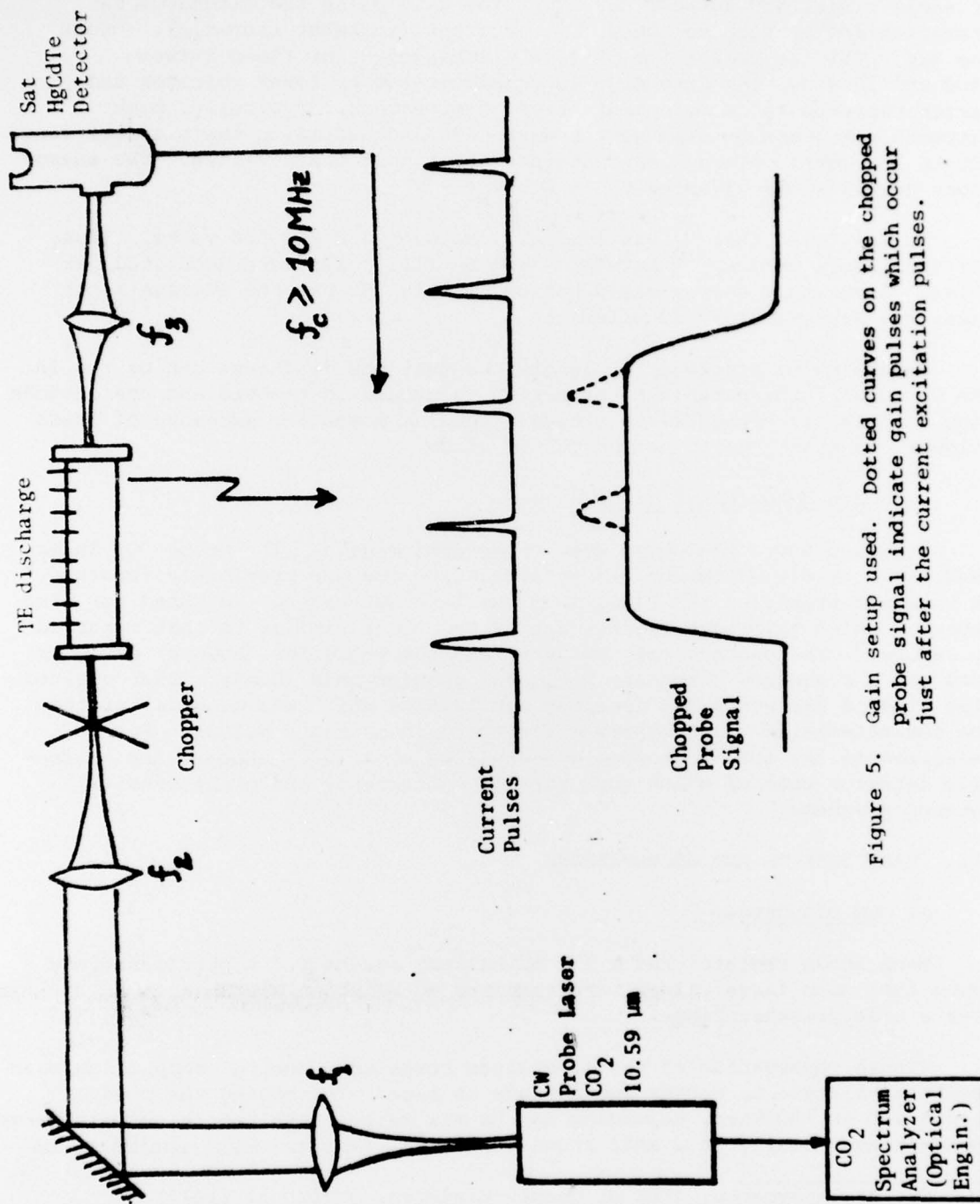

Figure 5. Gain setup used. Dotted curves on the chopped probe signal indicate gain pulses which occur just after the current excitation pulses.

inexorable, being only marginally deferred or reduced by increased cathode cooling, faster gas flow, or gas mixture variations. Except at pressures below 100 Torr, the luminous discharge column does not contact the side walls. Passage of a probe Helium-Neon (He-Ne) laser beam through the discharge section revealed considerably increased beam perturbations at pressures above 100 Torr. Reversing the role of the graphite anode slabs and copper cathode did not improve the appearance of the discharge.

The CW experiments were generally conducted with a closed cycle system. A recirculating pump allowed dwell times, in the discharge region, as short as 0.4 ms. However, flow speeds could be decreased by a factor of 3 if desired. Generally, at lower flow speeds, undesirable discharge characteristics appeared. Most notable was that the streamer-like discharges, at pressures above 100 Torr, lined-up in the center of the discharge region under slow flow or zero flow conditions. At the highest flow rates the discharges appeared nearly randomly positioned between the sidewalls. Gain measurements showed zero gain under zero flow conditions and best gain at higher flow rates. Best gain conditions appeared for a mix ratio of He:N<sub>2</sub>:CO<sub>2</sub>:CO:Xe equal to 67:20:8:3:2. No gain was measured unless copious amounts of N<sub>2</sub> were included in the mix. For this mixture, V-I curves revealed a negative discharge resistance of 700 kΩ at currents between 0.5 and 1.0 mA. Apparent gains (over the total length) between 3 and 5 percent were measured for pressures between 80 and 250 Torr at the near optimum discharge current per slab of 0.75 mA, i.e., 30 mA total.

From subsequent measurements of pulsed gain these modest gains should be adequate for laser action despite passive cavity losses. However, laser action was not obtained using mirror reflectivity sets of 99.6 percent and 99.6 percent or 99.6 and 97 percent despite the fact that pulsed gains less than 5 percent were adequate in producing laser action under identical mirror set and alignment conditions. It should be further noted that CW laser action was investigated with both open and closed cycle flow.

#### b. Pulsed Discharges

Visual observations of the pulse discharges were similar to those observed with CW discharges with no apparent important exceptions. However, despite the small measured pulsed gains laser action was found. Figure 6 shows the total gain of the 15 cm long discharge. Gain per unit length is very low and decreases when convective cooling is decreased. In this discussion, all results refer to a pulse repetition rate of 5 kHz.

Average laser power was detected with a Scientech 3620 power meter using two different output coupling mirrors, 95 percent and 97 percent, and a 99.6 percent rear mirror. Two premixed gases, for which gain measurements are shown in Figure 6, were used in open flow. These premixed gases, as well as other mixes, were used in a closed cycle, i.e., recirculating system, as well. When used in a closed cycle flow laser action was about 30 percent weaker than with open flow and the average power decayed toward zero within several minutes of operation. The optimum pressure for laser action when closed cycle flow was used was about 25 percent lower than was found to be the case in open flow, as recorded in Figure 7.

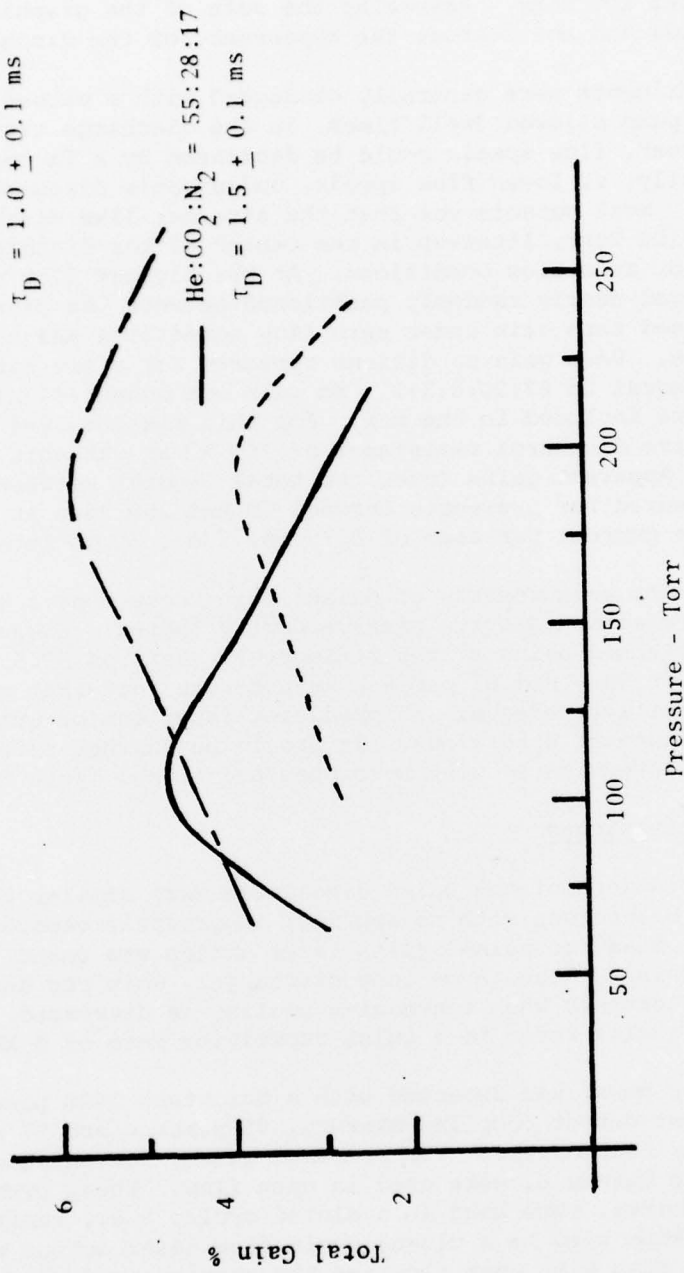

Figure 6. Total pulsed gain in 15 cm length versus pressure for different gas flows and mix ratios.  $\tau_D$  represents the dwell time of the gas in the discharge region. Open cycle flow. Cathode water cooled to  $220 \pm 20^\circ\text{C}$ . Pulse repetition rate was 5 KHz.

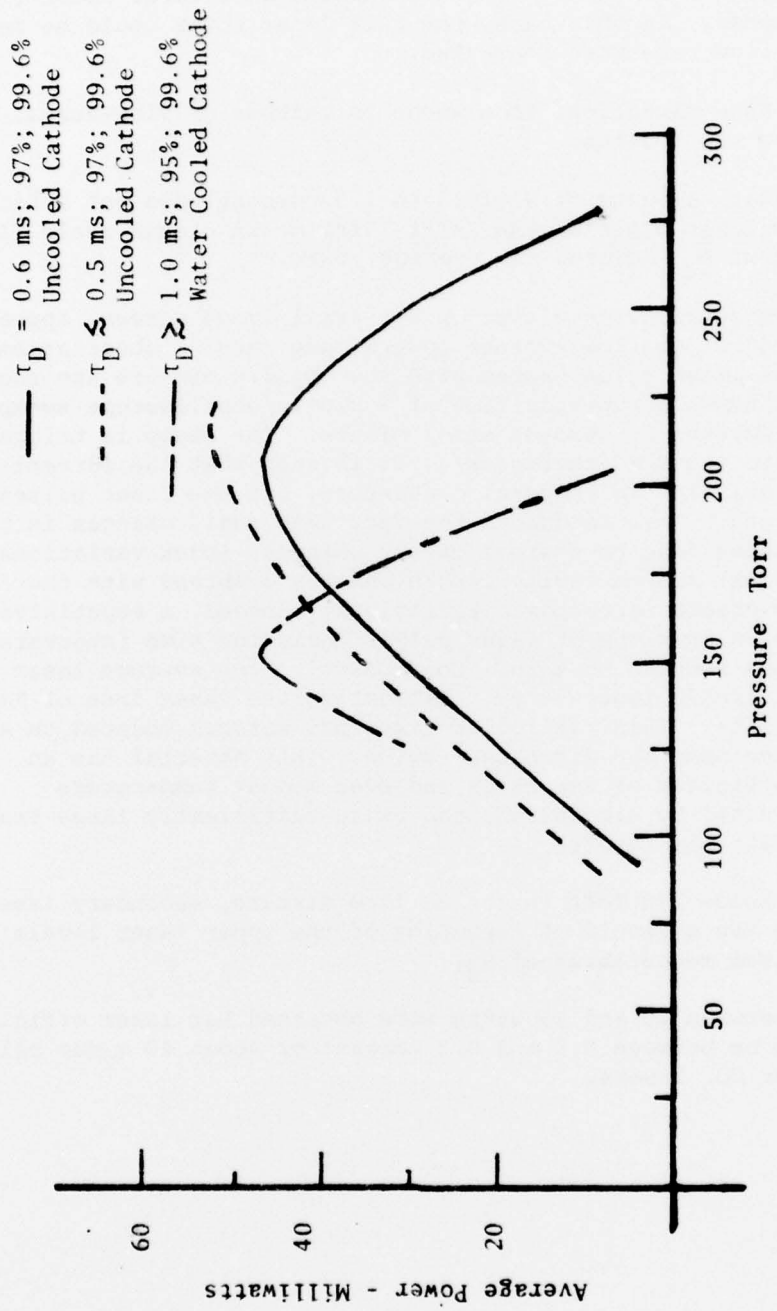

Figure 7. Average power versus pressure in open cycle flow using a premix gas He:CO<sub>2</sub>:N<sub>2</sub> in ratio of 80:12:8. Optimum voltages for each pressure were used. Mirror reflectivities are noted in legend.

Thus, 70 to 85 Torr was the optimum pressure range for the 55:28:17 mixture whereas 110 to 125 Torr was the optimum pressure range for the 80:12:8 mixture.

The laser was also operated in the sealed-off condition at zero flow. This resulted in further degradation of the laser power and shortening of lasing lifetime to less than 1 minute.

It was also noted that laser power was reduced when water cooling of the cathode was eliminated. In this case, the full laser power could be regained if the open-cycle flow rate were increased.

Changing the flow direction, from anode to cathode or vice-versa, did not markedly change the results.

Addition of small amounts of  $H_2$  (0.5 to 1.5 percent) did not affect either the average laser power or the laser lifetime in closed-cycle flow. Higher percentages of  $H_2$  reduced the average power.

The beam cross section, as viewed on a thermal image screen, appears symmetrically round but the low average powers made careful observation difficult. Typical laser pulse shapes with the 80:12:8 mixture are shown in Figure 8. This shows a superposition of 3 single oscilloscope sweeps separated in time between 30 seconds and 1 minute. The sweep is triggered by the gate pulse to the SCR (thyristor). It is seen that the current pulses reveal no variation in temporal occurrence, but the laser pulses show large variations. This is due to the fact that small changes in the Fabry Perot resonances (due to thermal cavity changes, index variations or mechanical variations) due to cavity length changes combined with the low gain of the system create large power variations. Indeed, a repetitive scope scan reveals an envelope of laser pulses including time intervals when laser power has been reduced to zero. Consequently, the average laser power can be considerably improved by constructing the laser free of Fabry Perot frequency drifts. This particular laser had mirrors mounted on a lucite box which enclosed the discharge region. This material has an extremely high coefficient of expansion and even modest temperature changes, such as caused by air drafts, can cause sufficiently large frequency variations to explain the results.

At pressures below 170 Torr in the 80:12:8 mixture, secondary laser peaks are seen and are a result of repumping of the upper laser levels by vibrationally excited metastables of  $N_2$ .

Peak powers between 10 and 25 watts were obtained but laser efficiencies were determined to be between 0.1 and 0.2 percent or about 40 times below values expected for  $CO_2$  lasers.

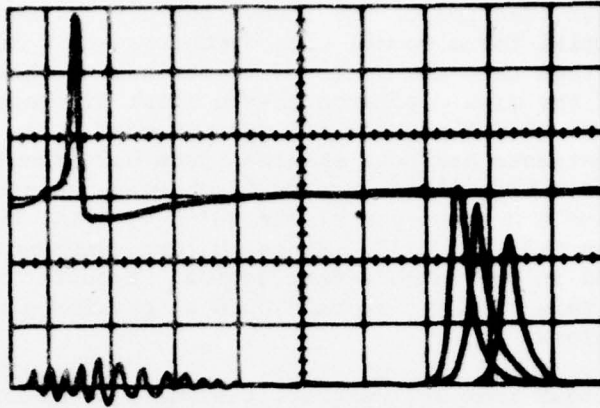

Figure 8. Superposition of 3 single oscilloscope traces separated in time between 30 seconds and 1 minute. Sweep is triggered by the gate pulse to the SCR. Top trace is that of discharge current. Bottom traces reveal laser pulses at different times. Different times of occurrence and peak laser heights due to thermal length variation of Fabry-Perot cavity mirrors separated by lucite box. Time base  $0.5 \mu\text{s}/\text{cm}$ .

#### IV. ANALYSIS

The TE laser investigated had low gain, low efficiency, and its high pressure operation was limited to a maximum of 250 Torr. The analysis below explains this poor performance. Visual observation reveals that the discharge fans out conically from the anode toward the cathode. At pressure exceeding 100 to 150 Torr, depending on the mix ratio, the discharges appear to contract radially. The effect on laser action is strongly negative. Columnar contraction reduces the volume excited while greatly increasing the gas temperature within the column. This reduces the gain. The discharge, restricted by ballast resistors, remains a glow. However, the close spacing of the electrodes does not allow adequate length for the discharge to radially expand and meet the sidewalls. Axially excited waveguide lasers have discharge lengths of sufficient length to render this effect negligible and allow the discharge to evolve into a wall confined glow.

The second effect in TE lasers which acts to limit their efficient operation is the role of the cathode. In CW discharges the cathode fall potential is a large fraction of the interelectrode voltage. If  $V_c$  is the cathode fall potential for a normal glow discharge and  $V$  is the total interelectrode voltage then the ratio of electrical discharge power in the positive column of the glow discharge to the total discharge power is  $(1 - V/V_c)$ . For the copper cathode and gas mix used  $V_c$  is taken to be 350 volts. This estimate has been obtained from our experimental observations and published tables.<sup>11,12</sup> For CW discharges, at pressures between 75 and 250 Torr, and a current per electrode of 0.75 mA, the ratio of  $V_c/V$  ranges between 0.82 and 0.35. Hence, a large percentage of the energy is consumed in the cathode fall region. Even for the overvolted pulsed discharges this ratio exceeds 0.16 at pressures over 200 Torr with helium rich discharges.

Thus, it is clear that at low pressures where a soft glow fills the discharge volume, the ratio  $V_c/V$  is so large that it severely limits efficient electrical excitation of the positive column whereas at higher pressures where  $V_c/V$  decreases the column contracts radially.

However, the above effects do not constitute the primary limitation of the glow discharges in small channel TE discharges. The energy deposited into the cathode fall region is deposited into a region of thickness,  $d_n$  where  $Pd_n = C_1$ .<sup>11,12</sup> In this case  $P$  is the pressure in Torr and  $C_1$  is a constant. The power density in the cathode fall region,  $P_c/v$  can then be computed as follows:

$$\frac{P_c}{v} = j_c \frac{V_c}{d_n} = j_c \frac{V_c P}{C_1} \quad (6)$$

where  $j_c$  is the current density at the cathode. If this is assumed to be spread uniformly over the cathode surface of area  $S$ , then

$$\frac{P_c}{v} = \left[ \frac{V_c}{SC_1} \right] I P \quad (7)$$

where  $I$  is the current and the terms in brackets are constants. For a given gas mix and ballast resistor, a stable glow discharge, at some optimum  $E/P$  value,  $E$  being the electric field, is found to require higher currents at higher pressures as indicated in Figure 9. Thus, from Eq. (7) and Figure 9 it is obvious that  $P_c/v$  increases more than linearly as the pressure  $P$  is linearly increased.

---

12. J. D. Cobine, "Gaseous Conductors," Dover, New York (1958), Chapter 8.

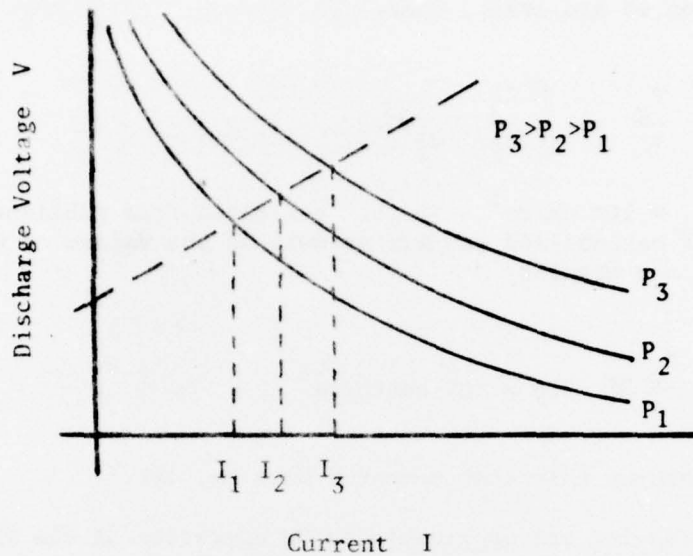

Figure 9. Typical V-I curves of glow discharges as parameters of pressure where  $P_1 < P_2 < P_3$ .

The desired line is determined by the optimum E/P value for the  $\text{CO}_2$  laser mix.

To estimate the values of  $P_c/v$  involved for the CW TE lasers, the following values are taken as reasonable estimates from published data.<sup>11,12</sup>  
 $V_c = 350$  volts,  $S = 2 \times 10^{-12}$   $\text{cm}^2$ ,  $c_1 = 0.75$  cm Torr. Thus, for a current of 0.75 mA per anode slab and a pressure of 200 Torr, one finds

$$\frac{P_c}{v} \approx 3.5 \times 10^3 \text{ W/cm}^3.$$

This value may be compared to power densities of  $100 \text{ W/cm}^3$  in axially excited channel waveguide lasers with similar cross sectional dimensions.

It is obvious that for the values assumed above very high fields, e.g.,  $V_c/d_p \approx 9.33 \times 10^5$  V/cm, and gas temperatures in the cathode region lead to high molecular dissociation and ionization rates. Diffusion of heat into the surrounding gas reduces the gain and creates anisotropy in the index-of-refraction.

A more accurate approach to the determination of the power density in the cathode region uses the relationship  $j_c/P^2 = \text{constant}$ ,  $C_2$ , for normal

glow discharges. This relationship quantifies the observation of radial contraction of the column at higher pressures where the cathode conducts only over a fraction of its area. Then,

$$\frac{P_c}{v} = \left[ \frac{C_2}{C_1} v_c \right] P^3 \quad (8)$$

Using a value of  $C_2 = 100 \text{ uA/cm}^2 - (\text{Torr})^2$  estimated from published tables<sup>11,12</sup> for our cathode and gas mix as well as the values of  $C_1$ ,  $v_c$  and  $P$  assumed earlier, one obtains

$$\frac{P_c}{v} \approx 3.8 \times 10^5 \text{ Watts/cm}^3$$

A value 100 times higher than that computed with Eq. (8).

The previous results are applicable to CW operation of the TE channel laser where the currents used, and therefore the current densities,  $j = I/S$ , were sufficiently small that  $j \leq j_n$  where  $j_n$  has previously been called  $j_c$  and is determined by  $j_n/P^2 = C_2$ . From the assumed value of  $C_2$

and this relationship, one finds that  $j \approx 40 \text{ mA/mm}^2$ . However, for pulsed TE discharges, where the average current per anode slab ranged between 125 and 250 mA the values  $j$  exceed  $j_n$  albeit not by much. For this case the discharge is classified as an abnormal glow. It is known that<sup>12</sup> for plane cathodes the cathode drop increases and the cathode fall thickness decreases for values of  $j/j_n$  exceeding 1. Consequently, the calculations of the power density deposited in the cathode fall region following Eq. (8) underestimate the power density  $P_c/v$ , in the case of TE pulsed discharges. In addition to the negative aspects previously discussed, one now anticipates shock waves to emanate from the cathode region. The highly heated slab of gas within the cathode fall region has a pressure greatly exceeding that of the surrounding gas and the classical description of shockwaves is fulfilled.<sup>13</sup>

Hence, the strongly negative aspect of the cathode fall region is manifested. Measurements reported<sup>14</sup> of the spatial gain in a transversely excited pulsed CO<sub>2</sub> laser revealed negative gain, i.e., absorption, near the cathode. These results are consistent with the preceding discussion.

Obviously, TE lasers cannot be efficiently operated for small channel dimensions unless (a) preionization can be generated to promote uniform volume excitation, (b) the large cathode voltage drop and energy deposition is greatly reduced, and (c) the anode strip linear density is increased to allow more uniform volume excitation and to reduce the current density.

13. R. Courant and K. O. Friedrichs, "Supersonic Flow and Shock Waves," Interscience Publishers, New York (1948).

14. T. F. Deutsch and R. I. Rudko, Appl. Phys. Lett. 20, 423 (1972).

## V. CONCLUSION

The experiments with conventional discharge geometries described in this report have shown that pulsed TE CO<sub>2</sub> channel lasers have low pulsed gains and efficiencies, 0.1 to 0.2 percent, and do not exhibit CW laser action. At pressures above 100 Torr these glow discharges are not wall confined. The discharge emanates from a point on the anode and conically spreads toward the cathode. The columnar radius decreases with increasing pressure leading to overlarge gas heating and low gain.\* At lower pressures where this effect is less pronounced a large fraction of the discharge energy is deposited in the cathode fall region rather than in the positive column of the glow. The extremely large electric fields and electrical power densities in the cathode fall region cause high ionization and molecular dissociation and greatly elevate gas temperatures. This not only limits the gain but also the sealed off lifetime. Consequently, to make an efficient pulsed TE laser with some limited lifetime capability one must greatly reduce the negative aspects of the cathode fall region. Secondly, it is believed that if this were done then efficient operation at repetition rates exceeding 5 kHz could be expected since the increased residual free electrons from previous discharges would serve to provide adequate and uniform preionization. To the extent that this requires corroboration, it may be noted that our experiments on TE and axial discharges in channel CO<sub>2</sub> lasers indicate significantly reduced voltage breakdown requirements at high repetition rates.

Given the importance of cathode processes in glow discharges a solution is indicated upon consideration of certain well known equations. The cathode fall,  $V_n$ , current density,  $j_n$ , and cathode fall distance,  $d_n$ , of a normal glow discharge are given by<sup>11,12</sup>

$$V_n = K_1 \ln \left( 1 + \frac{1}{\gamma} \right) \quad (9)$$

---

\*Earlier reported measurements on similar discharges in 1 mm square channel lasers revealed higher gains than reported here. Such higher gains are understandable, though laser efficiencies were still below 1 percent since the mode filling volume important in gain measurements depends on the channel area. This is true since the discharge is not wall confined. Furthermore, as reported in Reference 1, the anode sections were spaced 1 mm apart as opposed to our 1.6 mm thereby providing more uniform volume excitation. The above two effects serve to support gains higher than ours by  $(1.6)^3 = 4.1$ . Thermoelectric cooling of the cathode to lower temperatures, as indicated in Reference 1, would also contribute to the higher measured gains.

$$\frac{j_n}{p^2} = K_2 \frac{1 + \gamma}{\ln(1 + 1/\gamma)} \quad (10)$$

$$d_n = \frac{K_3}{P} \ln(1 + 1/\gamma) \quad (11)$$

where  $K_1$ ,  $K_2$ , and  $K_3$  are constants dependent only on gaseous constituents,  $P$  is the gas pressure and  $\gamma$ , the Townsend second ionization coefficient, is the probability of cathode electron emission under ion bombardment. This latter value has been measured for TE  $\text{CO}_2$  laser mixtures and copper electrodes.<sup>15</sup> Its value is,  $\approx 10^{-6}$ , considerably lower than might be expected from earlier reported values.<sup>16</sup> Increases of  $\gamma$  decreases both  $V_n$  and  $d_n$  while increasing  $j_n$ . The decrease of  $V_n$  and  $d_n$  means that less energy is dissipated in a shrinking cathode fall region. The increase of  $j_n$  implies that larger current densities  $j$  can be used while maintaining a normal glow.

A means of greatly increasing  $\gamma$  is discussed by Nasser<sup>6</sup> as an aspect of the Malter effect as well as by Francis.<sup>17</sup> The technique consists of coating the cathode with a thin dielectric layer such as  $\text{Al}_2\text{O}_3$ ,  $\text{SiO}_2$  or  $\text{MgO}$ . Positive ions, prevented by this layer from reaching the cathode accumulate on the surface and create large electric fields. These fields, up to  $10^6$  V/cm produce large field emission from the cathode surface. Additionally, the cathode fall now occurs in the dielectric layer so that heat evolved within this region is preferentially dissipated in the cathode to which it is bonded, thereby, reducing gas heating. An additional useful aspect has been mentioned by Francis who reports that at higher currents field emission predominates and the current becomes independent of gas pressure.

The degree to which the Malter effect is helpful in overcoming the limiting aspects of TE channel discharges remains an area for future research. A second and possibly simpler means of overcoming the difficulties discussed at length in this report is to use RF excitation. Preliminary experiments in this direction indicate that uniform CW excitation is obtained in TE discharges to pressures, 500 Torr, limited only by available power supplies. Excellent gain and efficient laser operation have been reported<sup>18</sup> for these cathodeless discharges which exhibit positive gaseous impedance.

15. E. A. Crawford and A. V. Phelps, *Appl. Phys. Lett.*, 25, 59 (1974).

16. J. D. Cobine, "Gaseous Conductors," Dover, New York (1958), Chapter 8, page 159.

17. G. Francis, *Encyclopedia of Physics*, Ed. by S. Flugge, VOL XXII, Springer-Verlag, Berlin (1956), pages 163, 164.

18. K. D. Laakman and D. Matz, Abstract - 1977 Conference on Laser Engineering Applications, Washington, D.C.

VI. REFERENCES

1. P. W. Smith, P. J. Maloney and O. R. Wood II, Appl. Phys. Lett 23, 524 (1973).
2. D. C. Smith, A. J. DeMaria, J. Appl. Phys. 41, 5212 (1970).
3. D. C. Johnson, IEEE J. Quant. Elect., QE-7, 185 (1971).
4. O. R. Wood II, P. W. Smith, C. R. Adams and P. J. Maloney, Appl. Phys. Lett., 27, 539 (1975).
5. P. W. Smith, C. R. Adams, P. J. Maloney and O. R. Wood II, Optics Commun., 16, 50 (1976).
6. E. Nasser, Fundamentals of Gaseous Ionization and Plasma Electronics, Wiley-Interscience, New York, 1971.
7. R. I. Rudko, IEEE J. Quant. Electron, QE-10, 497 (1974).
8. A. Papayoanou, IEEE J. Quant. Electron, QE-12, 27 (1977).
9. R. R. Jacobs, Rev. Sci, Inst., 44, 1146 (1973).
10. A. Fujisawa and A. Papayoanou, ECOM Tech Report 4326, May 1975.
11. R. Papoular, "Electrical Phenomena in Gases," American Elsevier Publishing Company, New York, NY, 1965 (Page 140).
12. J. D. Cobine, "Gaseous Conductors," Dover, New York (1958), Chapter 8.
13. R. Courant and K. O. Friedrichs, "Supersonic Flow and Shock Waves," Interscience Publishers, New York (1948).
14. T. F. Deutsch and R. I. Rudko, Appl. Phys. Lett. 20, 423 (1972).
15. E. A. Crawford and A. V. Phelps, Appl. Phys. Lett., 25, 59 (1974).
16. J. D. Cobine, "Gaseous Conductors," Dover, New York (1958), Chapter 8, page 159.
17. G. Francis, Encyclopedia of Physics, Ed. by S. Flugge, VOL XXII, Springer-Verlag, Berlin (1956), pages 163, 164.
18. K. D. Laakman and D. Matz, Abstract - 1977 Conference on Laser Engineering Applications, Washington, D.C.