

HDL-TR-1805

12

ADA044196

Interfacing the XM36E1 Fuze Setter
and the TACFIRE Tactical Computer

TR-1805—Interfacing the XM36E1 Fuze Setter and the TACFIRE Tactical Computer,
by Raymond J. Saker

June 1977

DDC
SEP 16 1977
RECEIVED
C

U.S. Army Materiel Development
and Readiness Command
HARRY DIAMOND LABORATORIES
Adelphi, Maryland 20783



FILE COPY

APPROVED FOR PUBLIC RELEASE; DISTRIBUTION IS UNLIMITED

the findings in this report are not to be construed as an
assessment of the Federal Reserve's policies or procedures
concerning such items.

Changes of management in these banks have been
noted in the report when it is felt that they are
of importance.

It is the opinion of the staff that the
information in this report is of value to the
Board of Governors.

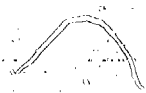

REPORT DOCUMENTATION PAGE		READ INSTRUCTIONS BEFORE COMPLETING FORM
1. REPORT NUMBER HDL-TR-1805	2. GOVT ACCESSION NO.	3. RECIPIENT'S CATALOG NUMBER
4. TITLE (and Subtitle) Interfacing the XM36E1 Fuze Setter and the TACFIRE Tactical Computer.	5. TYPE OF REPORT & PERIOD COVERED Technical Report	
7. AUTHOR(s) Raymond J./Baker	8. CONTRACT OR GRANT NUMBER(s) DA: 1T161101A9A1 PRON: A16RC00101A1A9	
9. PERFORMING ORGANIZATION NAME AND ADDRESS Harry Diamond Laboratories 2800 Powder Mill Road Adelphi, MD 20783	10. PROGRAM ELEMENT, PROJECT, TASK AREA & WORK UNIT NUMBERS Program 1: 6.11.01.A	
11. CONTROLLING OFFICE NAME AND ADDRESS U.S. Army Materiel Development & Readiness Command Alexandria, VA 22333	12. REPORT DATE June 1977	13. NUMBER OF PAGES 15
14. MONITORING AGENCY NAME & ADDRESS (if different from Controlling Office)	15. SECURITY CLASS. (of this report) Unclassified	15a. DECLASSIFICATION/DOWNGRADING SCHEDULE
16. DISTRIBUTION STATEMENT (of this Report) Approved for public release; distribution unlimited.		
17. DISTRIBUTION STATEMENT (of the abstract entered in Block 20, if different from Report)		
18. SUPPLEMENTARY NOTES DRCMS Code: 611101.11.84400 HDL Project No: A10643		
19. KEY WORDS (Continue on reverse side if necessary and identify by block number) Fire-control computer XM587 fuze TACFIRE XM36E1 fuze setter Electronic time fuze Battery computer system		
20. ABSTRACT (Continue on reverse side if necessary and identify by block number) By two different approaches, the XM36E1 fuze setter can be interfaced with the Tactical Fire Direction System (TACFIRE) tactical computer. One approach uses standard complementary metal oxide semiconductor (CMOS) logic; the second approach uses a micro-processor to provide a 'smart' interface. Both approaches recognize the time-setting portion of a fire-mission message as presented on the TACFIRE display at the battery level. This information is used		

163050

18

UNCLASSIFIED

SECURITY CLASSIFICATION OF THIS PAGE(When Data Entered)

to program the XM36E1 to set either the XM587E2 or the XM724 time fuze to the specified time. The battery personnel only have to place the setter on the fuze to be set.

UNCLASSIFIED

2 SECURITY CLASSIFICATION OF THIS PAGE(When Data Entered)

CONTENTS

	<u>Page</u>
1. INTRODUCTION	5
2. BACKGROUND	5
3. DISCRETE LOGIC APPROACH	7
4. MICROPROCESSOR APPROACH	9
5. CONNECTION BETWEEN TACFIRE AND INTERFACE	12
6. CONCLUSIONS AND RECOMMENDATIONS	13
DISTRIBUTION	15

FIGURES

1 Sample TACFIRE fire-mission message	6
2 Discrete logic approach to interface XM36E1 fuze setter to TACFIRE	8
3 Microprocessor approach to interface XM36E1 fuze setter to TACFIRE	10
4 Program to check TACFIRE message	11

ACCESS for

N IS Write Section
P.M. R.M. Section

CREATED BY: [unclear] COMES
SPECIAL

A

1. INTRODUCTION

The Tactical Fire Direction System (TACFIRE) was developed to provide a computer-controlled message-driven communications network. This network connects the artillery battalion command with the forward observer, battalion commander, battery commander, battery guns, and support organizations in the artillery system such as the supply depot. In addition to this message handling, TACFIRE accepts fire-mission commands and computes the coordinates, fuze type, fuze setting, and all other pertinent data required by the gun crew to fire a mission. This information is transmitted to the battery for execution. If the fuze selected is either the XM587E2 or the XM724 time fuze, the time information must be read from the TACFIRE display unit and set on the XM36E1 fuze setter which is then used to set the fuze. This report describes two approaches of interfacing the TACFIRE display at the battery level to the fuze setter. This interface eliminates delays and possible errors in transferring the time information from the display to the setter.

The proposed approaches use either discrete logic or a microprocessor. The discrete logic approach uses commercially available logic of the 4000 family of complementary metal oxide semiconductor (CMOS) integrated circuits (IC's). This is the simplest and most straightforward approach; however, it is the less flexible of the two. The second approach, which uses microprocessor control, is a bit more complicated since it uses a large scale integrated circuit (LSI) which is capable of tasks many orders of magnitude over the minimum required. The microprocessor offers much greater flexibility since it can be programmed to do complex data manipulating. The program can be changed easily to accommodate various information sources other than the TACFIRE system, such as the Human Engineering Laboratories Battalion Artillery Tests (HELBAT) fire-control system developed by the Human Engineering Laboratories and the Field Artillery Digital Automatic Computer (FADAC) fire-control system. In addition, it could be readily reprogrammed to work with the proposed Battery Computer System (BCS).

2. BACKGROUND

The setter interfaces to TACFIRE via the battery display unit (BDU). The BDU is located at the gun battery and consists of a data modem and an electronic printer. The data modem accepts information from the TACFIRE network and checks that the message being received is destined for this BDU. If so, the message is decoded, formatted, and sent to the electronic printer. The printer, in turn, provides a hard copy for the battery commander.

The messages can take on many formats. Information such as supply reports, weather information, and fire-mission commands are typical messages. The fire-mission command (fig. 1) is the only one of interest to the interface.

```
FM
FC
TGT:AAXXXX
FU:B/B/B/BB/BBB
ADJ:BBBB
SPINT:BBBBBBBBBBBBBBBB
SHL:BBBB
LOT:A/ACHG:X
FZE:BBBB           FUZE TYPE
PTF:BBBB
RD:XX
INEFF
RDS:XX/XX
ZF:XX/X
SH:BBBB/BBBB
LOTS:A/A/A/A
CHGS:X/X
FZ:BBBB/BPBB
MF:AAA/AAA/AA
DF:XXXX
TI:XX.X           TIME SETTING
QE:XXXX.X
TOF:XXX.X
RG:XXXXX
TOT:XX/X
TTF:XX/XX/XX
NLT:XX/XX
CONOPT:AAA
SIZE:XXXX/XXXX
ATT:XXXX
PTM:J
```

Figure 1. Sample TACFIRE fire-mission message.

Fire-mission commands can take two forms: immediate and preplanned. An immediate command gives a set of firing conditions (quadrant elevation, azimuth, fuze type, fuze setting, set time, ammunition type, etc.). As soon as this command is received, the guns are set as indicated, and the required number of rounds is fired. The preplanned mission has all the information contained in an immediate command plus additional information: the time and date that the mission is to be fired. Upon receipt of a preplanned fire mission, the battery commander

holds the information required to fire the mission until the prescribed time and day and then sends the firing information to the guns to be fired.

3. DISCRETE LOGIC APPROACH

The discrete logic approach (fig. 2) uses the standard 4000 series CMOS logic family to implement immediate fire-mission commands. This approach does not interface preplanned fire-mission commands, because the interface complexity increases the price 10 times. (A real-time clock and a memory are required.)

This approach uses a "T" connector adapter, which is inserted between the data modem and the printer. This connector allows the interface to tap off the data as they go to the printer without disturbing the normal data flow between the modem and the printer. The data are fed to the serial input of a shift register that has eight stages and is eight bits wide. The parallel outputs are fed to one set of inputs of a network of comparison gates. The other set of inputs of the comparison gates is fed from a read only memory (ROM) containing code words corresponding to the message words that the interface must recognize. A sequencer is used to select which word of the ROM is to be compared with the input data stream. When the interface is initialized, the sequencer is set to the start position and the first word of the ROM is selected. The interface is now looking for the string of American Standard Code Information Interchange (ASCII) characters corresponding to the preamble of an immediate fire-mission command.

When the proper sequence of ASCII characters is recognized, the sequencing counter advances and starts looking for the sequence of characters that designates the fuze type. When it recognizes this sequence, it checks that the fuze type is either an XM587E2 or an XM724. If the fuze type is other than one of these two, the interface resets to the initial condition and starts looking for a new fire-mission command. If one of the fuzes of interest is recognized, then the sequencer advances again to look for the sequence of characters representing the set time. The sequencer decodes the set time and formats it to be used to program the setter, stores the programming information in a register, and enables the setter. If a fuze is placed in the setter before the setter is enabled, the fuze is not set and thus cannot be set to an incorrect or invalid time. The set time remains valid until the start of another fire-mission command is recognized by the interface.

The XM36E1 setter uses the set time data as follows: When the fuze setter is turned on by being placed on a fuze, the setter generates a counter reset pulse. This pulse resets the cross-coupled AND gate flip-

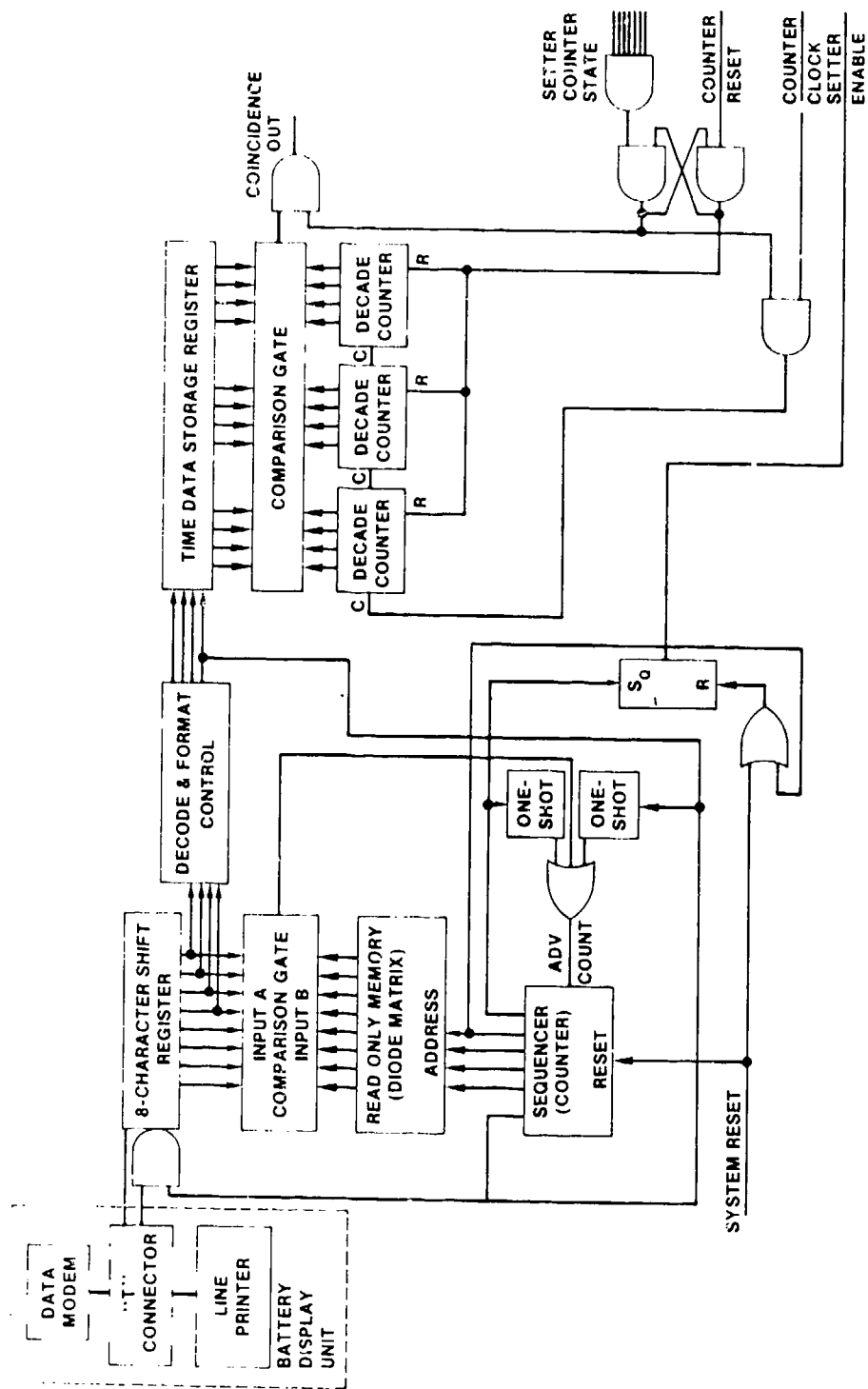

Figure 2. Discrete logic approach to interface XM36E1 fuze setter to TACFIRE.

flop circuit (fig. 2), which resets the four-digit decade counter and blocks the coincidence signal from leaving the last gate of the comparison gate. When the fuze setter counter reaches the count 010003 ($A_3B_0C_0D_0E_1F_0$ all equal to logic 1), the cross-coupled flip-flop switches; this transition removes the reset from the decade counters and allows a coincidence signal to be transmitted to the setter. The counter counts the A_9 pulses from the setter, each of which represents 0.1 s of fuze set time. The output of the counter and the specified set time are continuously compared and, when a match is obtained, the coincidence pulse is issued to the setter. This pulse commands the setter to stop fuze setting and store the set time in the fuze memory. This same count-and-compare operation is performed once again to verify that the fuze has been set within the specified tolerance.

4. MICROPROCESSOR APPROACH

The proposed microprocessor approach (fig. 3) uses the Motorola M6800 microprocessor. Since the microprocessor is fast and has extensive computational and decision-making abilities, it can do more complex tasks in addition to all of the decoding, formatting, counting, and comparing performed by CMOS logic. Since the microprocessor has a moderate amount of memory (at least 128 words), it stores information and presents it to the setter at the appropriate times as determined by a real-time clock, thereby allowing the implementation of preplanned fire missions. An additional advantage to the use of a microprocessor is that it is controlled by software (the program) rather than hard wired to a specific function. By a change in the control memory (a single ROM IC), the interface can respond to an entirely different set of messages and accept an entirely different code (i.e., the Gray code or the EBCDIC instead of the ASCII).

The TACFIRE system is accessed through a "T" connector placed between the data modem and the line printer. The data obtained from TACFIRE are entered into the microprocessor through half of a peripheral interface adapter. This circuit, a single commercially available IC, takes care of the interface between a peripheral device and the microprocessor. As TACFIRE presents each character to the microprocessor, it checks if the message is of interest to the setter interface by a program (fig. 4) stored in the microprocessor's control memory. If the message is of interest, the pertinent data are stored in the microprocessor random access memory for use at a later time. If the message is of no interest, it is ignored, and the microprocessor continues with other tasks.

If the fire-mission command is immediate, then the microprocessor immediately processes the set time and makes it available to the setter-control circuitry. If the fire-mission command is preplanned, then the

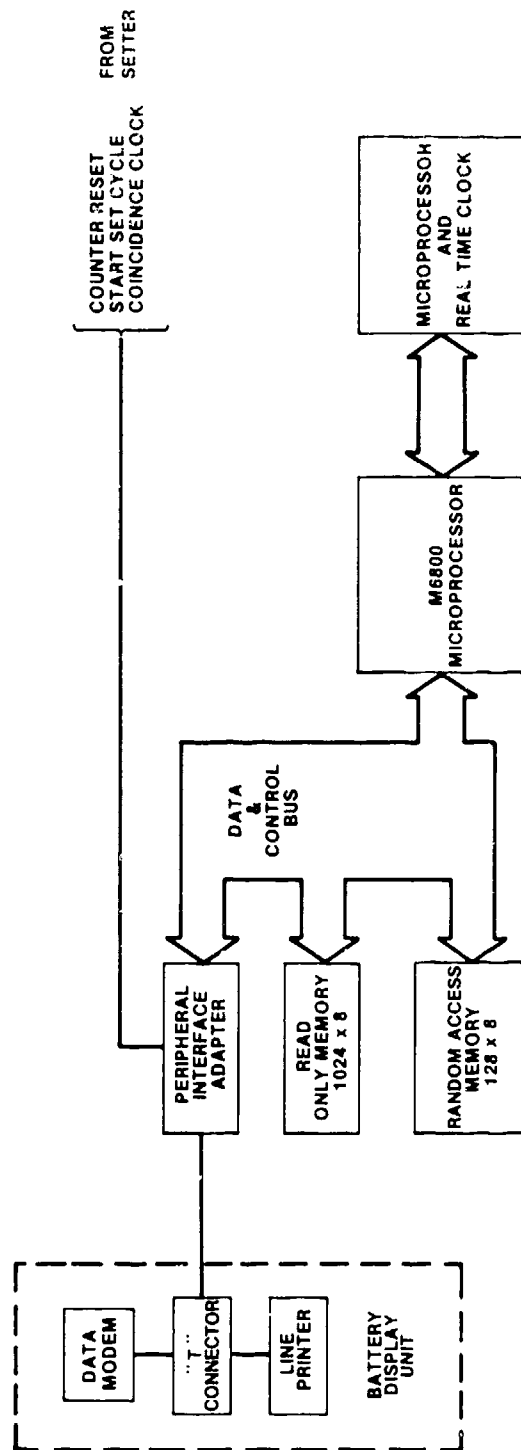

Figure 3. Microprocessor approach to interface XM36E1 fuze setter to TACFIRE.

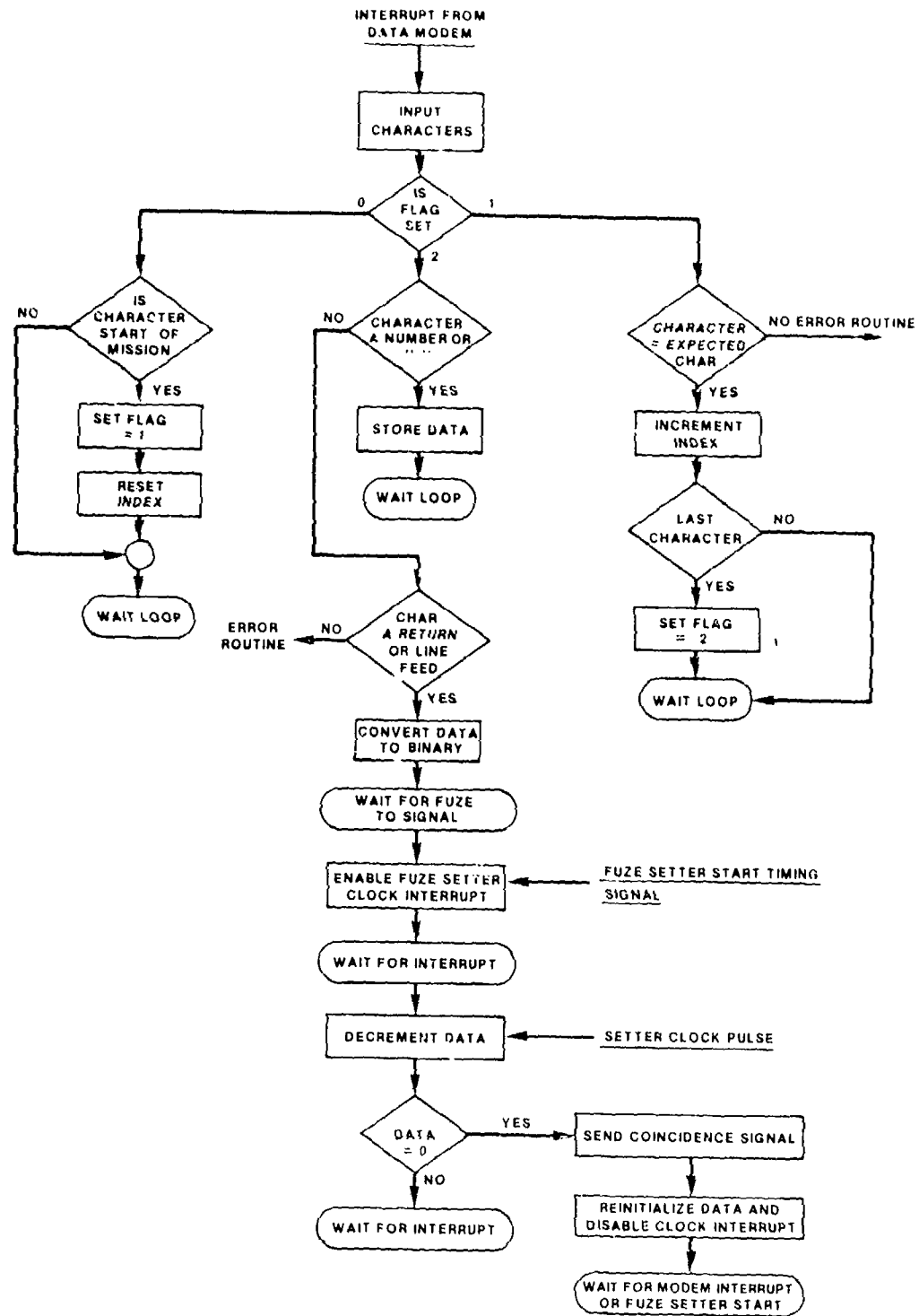

Figure 4. Program to check TACFIRE message.

information is stored and presented a short time before the mission is to be fired. The time of day is determined by a real-time clock, which is set by the operator when the power to the system is turned on.

The fuze setting sequence is as follows: The data received from TACFIRE are decoded into a three-digit binary coded decimal (BCD) number. This BCD number is then converted into an equivalent binary number, and a constant factor is added to it. This sum is the count at which the microprocessor must signal the setter to stop counting pulses and set the time into the fuze memory. When the setter is placed on a fuze, a sequence of operations starts within the setter. First, a counter-clear operation signals the microprocessor that the fuze setting sequence has started. Then the microprocessor sets an internal register equal to the desired count and waits for a start signal from the setter. When it receives the start signal, the microprocessor decrements an internal counter as it receives each setter clock pulse and tests for the register equal to zero. If the register equals zero, the microprocessor issues the coincidence signal to the setter to set the fuze memory.

The real-time clock is run by a crystal-controlled oscillator and a divider string. The divider output is 1 pulse/s, which increments a counter. The microprocessor requests the time of day from the operator as part of the power-on sequence. The operator then enters the time of day via data entry switches on the interface. This time is added to the contents of the counter to obtain the real time of day. This clock is frequently checked against the planned firing times of pending fire missions. When the time for a fire mission is near, the microprocessor alerts the battery commander by an audio-visual alarm and places the fuze setting information on the line, so that it is available to the setter.

5. CONNECTION BETWEEN TACFIRE AND INTERFACE

There is one possible problem in connecting TACFIRE to an interface. The BDU is typically 15 to 100 m from the gun. Since the data are available from the TACFIRE network at the BDU and the ammunition and setters are at the gun, a difficulty arises in getting the data from TACFIRE to the gun.

There are two possible solutions to the problem. The first and least expensive is a land line of WD-1 or similar communication cable. The more exotic solution is a small, low-power radio link from the BDU to each interface. However, neither solution has been discussed with the artillery user for the desirability of having land lines or radio links.

6. CONCLUSIONS AND RECOMMENDATIONS

Although both approaches are feasible, the microprocessor is the one worthy of being considered for further development and building of hardware.

The time required to design and assemble the hardware should be approximately the same. The software development time will probably be negligible compared with the hardware design and fabrication time, and it can be developed in parallel with hardware design and fabrication. When completed, the microprocessor will be able to interface the XM36E1 to TACFIRE. With a small reprogramming cost (no more than 1 man-month), the microprocessor can be made to work with other systems such as HELBAT and FADAC.

Moreover, the microprocessor can detect and correct errors on received messages, compute firing coordinates for local fire missions, and inventory local stockpiles. Some sort of data entry and display device and additional programming effort would be required for full use of the microprocessor.

Preceding Page BLANK - NOT FILMED

DISTRIBUTION

DEFENSE DOCUMENTATION CENTER
CAMERON STATION, BUILDING 5
ALEXANDRIA, VA 22314
ATTN DDC-TCA (12 COPIES)

COMMANDER
USA RSCH & STD GP (EUR)
BOX 65
FPO NEW YORK 09510
ATTN LTC JAMES M. KENNEDY, JR.
CHIEF, PHYSICS & MATH BRANCH

COMMANDER
US ARMY MATERIEL DEVELOPMENT &
READINESS COMMAND
5001 EISENHOWER AVENUE
ALEXANDRIA, VA 22333
ATTN DRXAM-TL, HQ TECH LIBRARY

COMMANDER
USA ARMAMENT COMMAND
ROCK ISLAND, IL 61201
ATTN DRSAR-ASF, FUZE DIV
ATTN DRSAR-RDF, SYS DEV DIV - FUZES

COMMANDER
USA MISSILE & MUNITIONS CENTER & SCHOOL
REDSTONE ARSENAL, AL 35809
ATTN ATSK-CTD-F

HARRY DIAMOND LABORATORIES
ATTN LOWREY, AUSTIN, III, COL, COMMANDER/
FLYER, I.N./LANDIS, P.E./
SOMMER, H./OSWALD, R. B.
ATTN CARTER, W.W., DR., TECHNICAL
DIRECTOR/MARCUS, S.M.
ATTN KIMMEL, S., PAO
ATTN CHIEF, 0021
ATTN CHIEF, 0022
ATTN CHIEF, LAB 100
ATTN CHIEF, LAB 200
ATTN CHIEF, LAB 300
ATTN CHIEF, LAB 400
ATTN CHIEF, LAB 500
ATTN CHIEF, LAB 600
ATTN CHIEF, DIV 700
ATTN CHIEF, DIV 800
ATTN CHIEF, LAB 900
ATTN CHIEF, LAB 1000
ATTN RECORD COPY, BR 041
ATTN HDL LIBRARY (3 COPIES)
ATTN CHAIRMAN, EDITORIAL COMMITTEE
ATTN CHIEF, 047
ATTN TECH REPORTS, 013
ATTN PATENT LAW BRANCH, 071
ATTN GIDEP OFFICE, 741
ATTN LANHAM, C., 0021
ATTN BAKER, R. J., 430 (10 COPIES)