

AD-A044 354

ARMY ENGINEER WATERWAYS EXPERIMENT STATION VICKSBURG MISS F/G 14/2
SIGNAL CONDITIONING SYSTEM FOR VELOCITY GAGES.(U)
MAR 70 F P HANES

UNCLASSIFIED

WES-MP-0-70-1

NL

1 of 1
ADA044354



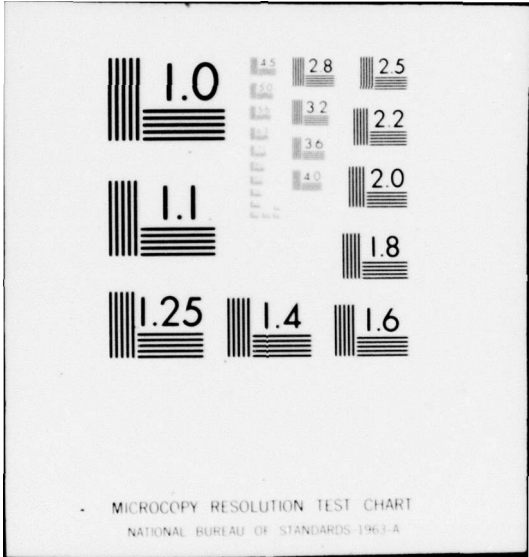

AD-A044354

1

DDC
RECEIVED
SEP 28 1977
D

DISTRIBUTION STATEMENT A
Approved for public release;
Distribution Unlimited

LIBRARY BRANCH
TECHNICAL INFORMATION CENTER



U. S. Army Engineer Waterways Experiment Station
CORPS OF ENGINEERS
Vicksburg, Mississippi

1A7
W34m
No. 8-70-1



MISCELLANEOUS PAPER O-70-1

SIGNAL CONDITIONING SYSTEM FOR VELOCITY GAGES

by

F. P. Hanes

US-CE-C
Property of the United States Army

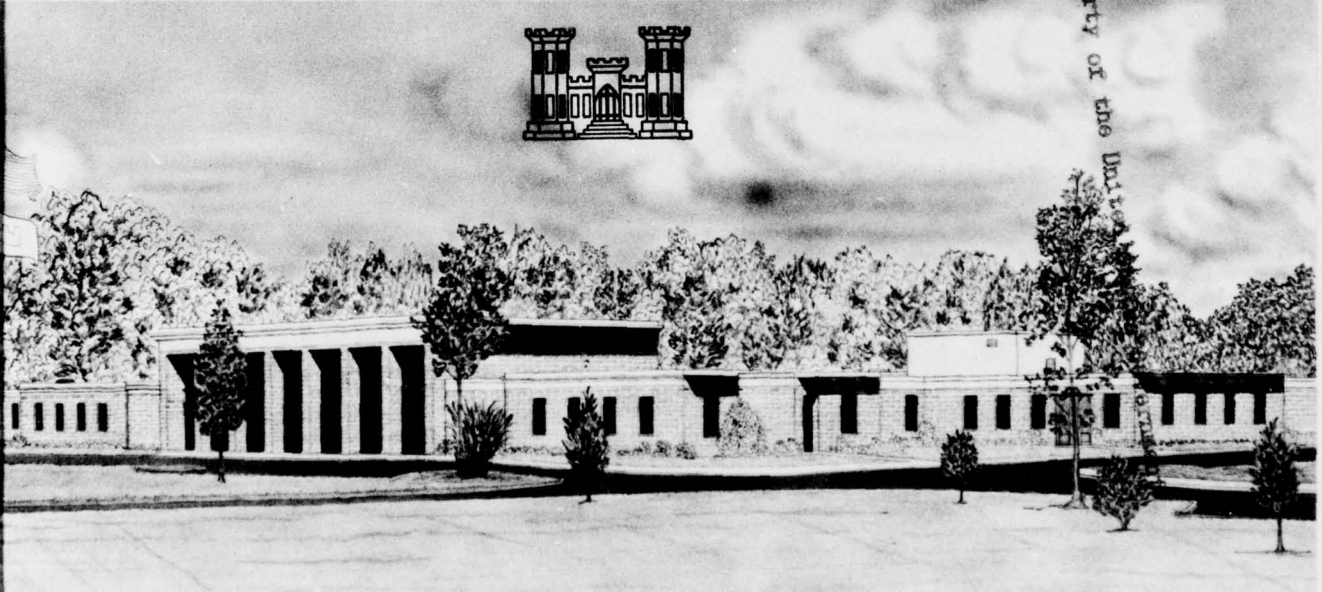

March 1970

Sponsored by **Defense Atomic Support Agency**

Published by **U. S. Army Engineer Waterways Experiment Station, Vicksburg, Mississippi**

RESEARCH CENTER LIBRARY
US ARMY ENGINEER WATERWAYS EXPERIMENT STATION
VICKSBURG, MISSISSIPPI

This document has been approved for public release and sale; its distribution is unlimited

Destroy this report when no longer needed. Do not return
it to the originator.

The findings in this report are not to be construed as an official
Department of the Army position unless so designated
by other authorized documents.

AD-A044354



MISCELLANEOUS PAPER O-70-1

SIGNAL CONDITIONING SYSTEM FOR VELOCITY GAGES

by

F. P. Hanes



March 1970

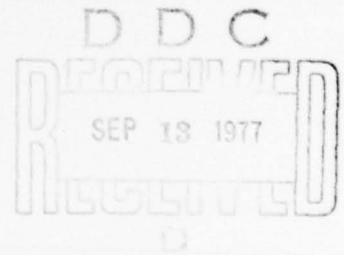

Sponsored by **Defense Atomic Support Agency**

Published by **U. S. Army Engineer Waterways Experiment Station, Vicksburg, Mississippi**

ARMY-MRC VICKSBURG, MISS.

This document has been approved for public release and sale; its distribution is unlimited

TAT
W34m
No. O-70-1

PREFACE

This paper was prepared for presentation at the Nuclear Weapon Effects Simulation Symposium held 12 and 13 March 1970 at Albuquerque, New Mexico, and sponsored by the Air Force Special Weapons Center, Kirtland Air Force Base, New Mexico.

Design and construction of the signal conditioning system discussed herein were funded by Defense Atomic Support Agency with Air Force Weapons Laboratory as the coordinator and monitor of the work. The work was accomplished at the U. S. Army Engineer Waterways Experiment Station during the period March through November 1969 by Mr. S. R. Emerson and Mr. F. P. Hanes, Chief, Engineering Branch, Instrumentation Services Division. This paper was prepared by Mr. Hanes.

Director of the Waterways Experiment Station during the accomplishment of this project and the preparation of this paper was COL Levi A. Brown, CE. Technical Director was Mr. F. R. Brown.

69638

| | |
|---------------------------------|---|
| ACCESSION BY | |
| DTIC | Write Section <input checked="" type="checkbox"/> |
| DDO | Dist Section <input type="checkbox"/> |
| DATA PROGRAMS | <input type="checkbox"/> |
| JCS/PRACTICE | |
| BY | |
| DISTRIBUTION/AVAILABILITY CODES | |
| SPECIAL | |
| A | |

SIGNAL CONDITIONING SYSTEM FOR VELOCITY GAGES

by
Francis P. Hanes

ABSTRACT

This paper describes the engineering design and constructional details of a solid-state signal conditioning system developed for use with the DX velocity gage. This circuit was originally developed for and used on HEST V. More recently the circuit was redesigned to add a reactive balance control, and 192 channels of these devices were built for use on ROCKTEST II. The paper discusses dynamic response of the system including frequency response, step function response, and overall system response with a fast-rise velocity pulse imparted to the DX gage. Also included is a description of a novel method of synchronizing the carrier oscillators in a multichannel system to avoid carrier beats.

Introduction

A solid-state signal conditioning system has been designed and constructed for use with variable reluctance velocity gages. Compared to commercially available equipment of this type, the principal advantages of the system described herein are cost, size, and performance. Although various configurations of the basic system as developed for the HEST V test have been used, this discussion will be limited to the particular configuration built by USAEWES for the ROCKTEST II event. This work was performed with Defense Atomic Support Agency (DASA) funding with Air Force Weapons Laboratory (AFWL) as the coordinator and monitor of the work.

Design

General description

In general, the system consists of a 3-kHz oscillator, an AC bridge network which includes the transducer, a demodulator, a filter, and an amplifier. The 3-kHz signal conditioning system was designed for use with DX variable reluctance velocity gages. However, any transducer using the general principle of magnetic flux coupling (variable reluctance), such as linear variable differential transformers, may be used. The system was designed to drive magnetic tape recorders or high-level voltage controlled oscillators (VCO) in multiplex systems. There is sufficient output power to drive sensitive galvanometers in order to record gage calibrations on oscillographs, but the output power is insufficient to drive galvanometers having frequency response sufficient to take advantage of the system frequency response capability. Thus, if full frequency range oscillographic recordings are required without use of magnetic tape machines, galvanometer drivers must be used with the system described herein.

Circuit description

The 3-kHz carrier system designed for ROCKTEST II consisted of 192 signal conditioning channels. These channels were constructed in

card cages (fig. 1) with 12 bridge balance, amplifier, demodulator (signal conditioner) cards and one oscillator card in each of 16 cages. The cages were designed for rack mounting in standard 19-in. racks. All power services and input-output connections were located on the rear panel (fig. 2). In order to prevent carrier beats from appearing in the output, which usually occurs if several oscillators are used in a carrier system, an oscillator synchronizer was designed and applied to the total system; this device will be described in the detailed discussions which follow. Carrier beats are produced in a carrier system with several oscillators as a result of slightly different oscillator frequencies together with the inevitable stray magnetic coupling that exists in system wiring. This condition produces low frequency excursions of the static output voltage from the carrier system and can be quite objectionable in reduction of data. The usual commercial practice to prevent carrier beats consists of assigning one oscillator in a system as master while all others are slaved and simply serve as isolation amplifiers. The objection to this method is that if the master oscillator fails at a critical time in a test, the entire carrier system is lost. Through the use of multiple (but synchronized) oscillators, the system designed for ROCKTEST II is not subject to this type of catastrophic failure. Loss of one oscillator will result in loss of only 12 channels of information. On the other hand, loss of the oscillator synchronizer will not cause loss of data channels, although some channels may be contaminated with carrier beats. This method of operation was considered to offer the best trade-off in terms of possible failure modes. The use of multiple power supplies reduces the probability of large data channel losses resulting from component failure in this area.

The printed circuit cards used in this system were made from 1/16-in. glass epoxy with 2-oz copper. After etching, the remaining copper on the circuit boards was coated by hot tin fusing. The contact pads at the socket end of the board were protected with a hard gold plating 50 millionths of an inch thick. Components used were standard tolerance devices readily available from electronic parts supply houses.

Resistors and capacitors were generally $\pm 5\%$ tolerance except for the bridge completion and ring demodulator circuits.

Component Features

Oscillator

The 3-kHz oscillator board used in this system is shown in fig. 3. The circuit consists of a Colpitts oscillator followed by a buffer amplifier. This particular design lends itself to frequency synchronization by injection of a synchronizing pulse into the base circuit of the oscillator transistor. The oscillator frequency is adjustable over a range of ± 75 Hz (approximately) about the nominal value of 3 kHz. The oscillator circuit diagram is shown in fig. 4. The loaded output is a sine wave of approximately 10 volts RMS.

Signal conditioner cards

Each signal conditioner (fig. 5) consists of a buffer amplifier, bridge circuit, demodulator, filter, and amplifier. The buffer amplifier serves to isolate the oscillator from other channels, thus reducing power requirements of the oscillator and reducing the likelihood of cross-talk between channels. An excitation control is associated with the buffer amplifier which allows channel-by-channel control of excitation. The bridge circuit is made up of the transducer, bridge completion resistors, and a means to resistively balance the bridge. The bridge output signal is transformer-coupled to the ring demodulator. Oscillator (carrier) injection into the ring demodulator is accomplished with another transformer as shown in fig. 6. The phase-sensitive output from the ring demodulator is connected to the filter where 3-kHz components and higher harmonics are removed. The filter is a modified elliptical function low pass design. To provide reactive balance, a signal is derived in the bridge circuit and injected into the filter by way of a phase-shifting network.

The filter output is connected to the inverting input of an operational amplifier with feedback set for a gain of 150. The operational amplifier is an integrated-circuit device with input and output

frequency compensating networks. The device used in this design was the type 709 operational amplifier.

Calibration of the system is performed by the usual method of shunting adjacent corners of the bridge with a resistor. In this design, provision for automatic calibration was made by use of a relay mounted on each card. In addition to connecting the calibration resistor, a spare form C set of contacts has been brought out for remote indication of the condition of the calibration relay.

Oscillator synchronizer

The oscillator synchronizer (fig. 7) furnishes the means by which all oscillators are maintained at the same frequency in order, as previously discussed, to avoid carrier beats. The synchronizer makes use of a 3-kHz fork oscillator with a frequency accuracy of $\pm 0.01\%$. The 3-kHz signal is amplified through a power amplifier stage which is terminated in 50 ohms. This circuit diagram is shown in fig. 8. The synchronizing signal is wired, by means of coaxial cable, to all card cages. The signal is presented to each oscillator card through a diode-resistor network located on each oscillator board. The synchronizer will pull the oscillator approximately 100 Hz from either the high or low frequency side of the desired 3 kHz. In practice, each oscillator is set to 3 kHz after warmup so that in the remote possibility that the oscillator synchronizer fails, the unsynchronized oscillators will be approximately correct. This is done because of the effect of carrier frequency on bandwidth and noise output.

Performance

Static characteristics

The 3-kHz system herein described was tested with 2,000 feet of cable between the velocity gage and the signal conditioner. The residual carrier and noise at balance was typically 5 millivolts peak-to-peak (1.75 millivolts RMS). The noise voltage at full output of 8 volts DC was 25 millivolts peak-to-peak (8.75 millivolts RMS). Gain for a system of this type is difficult to state in meaningful terms without

relating it to the overall system. Therefore, the term gain performance is used to describe this parameter. Table 1 shows typical relationships

Table 1
Typical Relationships Showing System Gain Performance

| <u>Calibration Resistor ohms</u> | <u>Equivalent Velocity ft/sec</u> | <u>Excitation Voltage RMS</u> | <u>Output Volts DC</u> |
|--------------------------------------|---------------------------------------|-----------------------------------|----------------------------|
| 8.5K | 30 | 4 | 2.00 |
| 21.0K | 20 | 6 | 1.80 |
| 30.0K | 10 | 7 | 0.85 |
| 60.0K | 5 | 8 | 0.80 |

between calibration resistor, equivalent velocity, excitation, and output voltage. This table furnishes more practicable and useful information about the system performance than could be inferred from a single gain figure. Gain performance shows an adequate output, in this case at least 800 millivolts, for a moderately low full scale velocity range. Generally used magnetic tape machines and VCO's produce full deviation for about 500 millivolts of input signal; therefore, a high signal to noise ratio will be maintained. Power required for each cage of 12 cards and one oscillator is 1.25 amperes at 24 volts DC. Drift, after 30 minute warmup, is less than 1 millivolt per hour.

Dynamic response

In order to evaluate dynamic response, the signal conditioner was examined under conditions of sinusoidal input to determine steady-state frequency response, response to a step input, and actual measurements wherein a velocity gage was caused to produce a fast-rise velocity pulse. The frequency response for the sinusoidal case is shown in fig. 9. In order to perform this test, a ring modulator circuit was used (fig. 10). Due to the frequency response characteristics of the transformer in the ring modulator circuit, it was useful only above about 50 Hz. A technique was developed to allow investigation of frequency response below 100 Hz and extending to DC. This circuit (fig. 11) makes use of a field

effect transistor (FET) to switch a calibration resistor in and out of the signal conditioner bridge circuit. In operation, a resistor is selected to compensate for FET characteristics so that an output is obtained which is equivalent to the calibration resistor applied in the conventional manner. Then, by driving the gate of the FET with the square-wave output of a function generator, the calibration resistor is switched in the bridge circuit at a rate set by the function generator.

The response of the system to a step input is shown in fig. 12. This response shows an overshoot of about 18% which, based on second-order linear system response theory, corresponds to a system with a damping factor of about 0.5. This overshoot is not objectionable in practice because the velocity transducer is obviously incapable of producing a step output. This is based on the fact that the velocity transducer is, in reality, an overdamped accelerometer. The transducer, then, approximates a linear second-order mass-spring-damper system with damping so great that the output of the transducer is predominantly a function of the velocity of the motion imparted over the frequency range of interest.

In order to investigate the practical dynamic response characteristics of the entire system including the transducer, tests were made on a drop tower located at the Civil Engineering Research Facility (CERF) on Kirtland Air Force Base. In these tests a velocity transducer and two reference accelerometers were mounted in a canister near the base of the drop tower. A shock force was imparted to the canister by the sudden release of a 40-pound weight suspended several feet above the canister. The canister used compressed styrofoam as a pulse-shaping isolation pad and, upon impact, the canister was accelerated and allowed to fall about 3 feet. Results of these tests are shown in fig. 13. The velocity pulse shown has a rise time of about 0.8 millisecond. During the tests, the 3-kHz carrier was monitored simultaneously with the system output. The upper trace in the photograph (fig. 14) shows the carrier. In addition to the reference accelerometers, velocity was monitored directly on the drop tower by means of a set of pin-contacts displayed on a raster scope. Thus, the drop tower offers a means to

evaluate
trace, a
celerome
grated t
a knowle
transduc
evaluati
the acc
It
a 1-mill
velocity
therefor
to a ste

The
of perfo
any know
is avail
complexi
be utili
tations
to be th
cable.
an undes
electron
canister
introdu
ROCKETES
the gre
rise ti
\$250 pe
synchr

evaluate the velocity transducer output alone, by observing the carrier trace, and the total system, by observing the output trace. The accelerometer trace shows the nature of the shock input and can be integrated to produce a velocity-time history. The raster scope furnishes a knowledge of the velocity imparted to the canister containing the transducer. Incidentally, the accelerometer trace also yields a quick evaluation of approximate velocity rise time since the base width of the acceleration pulse approximates the velocity rise time.

It was concluded from these tests that the carrier system follows a 1-millisecond or greater rise time with no overshoot and that the velocity transducer has a rise time of 1 millisecond or greater and therefore cannot produce the overshoot that the system shows in response to a step input.

Concluding Remarks

The 3-kHz carrier system described herein attained a higher degree of performance with the DX velocity transducer than is available with any known commercial system of this general type. A commercial system is available which allows greater system bandwidth; however, cost and complexity are considerably higher. The greater system bandwidth cannot be utilized effectively with the DX gage because of the basic gage limitations discussed previously. The only advantage of this system appears to be the ability to multiplex several DX gages on a single coaxial cable. In light of our operating experience, this is considered to be an undesirable mode of operation since in field use this requires that electronic signal conditioning elements be located in the velocity gage canister. This simply creates additional failure hazards as well as introducing the possibility of shock sensitivity. The system for ROCKTEST II described herein achieves what is generally concluded to be the greatest bandwidth capability of the DX gage (i.e., 1-millisecond rise time) at a modest cost. Cost of the system described herein was \$250 per channel including the rack mounting cages and oscillator synchronizer.

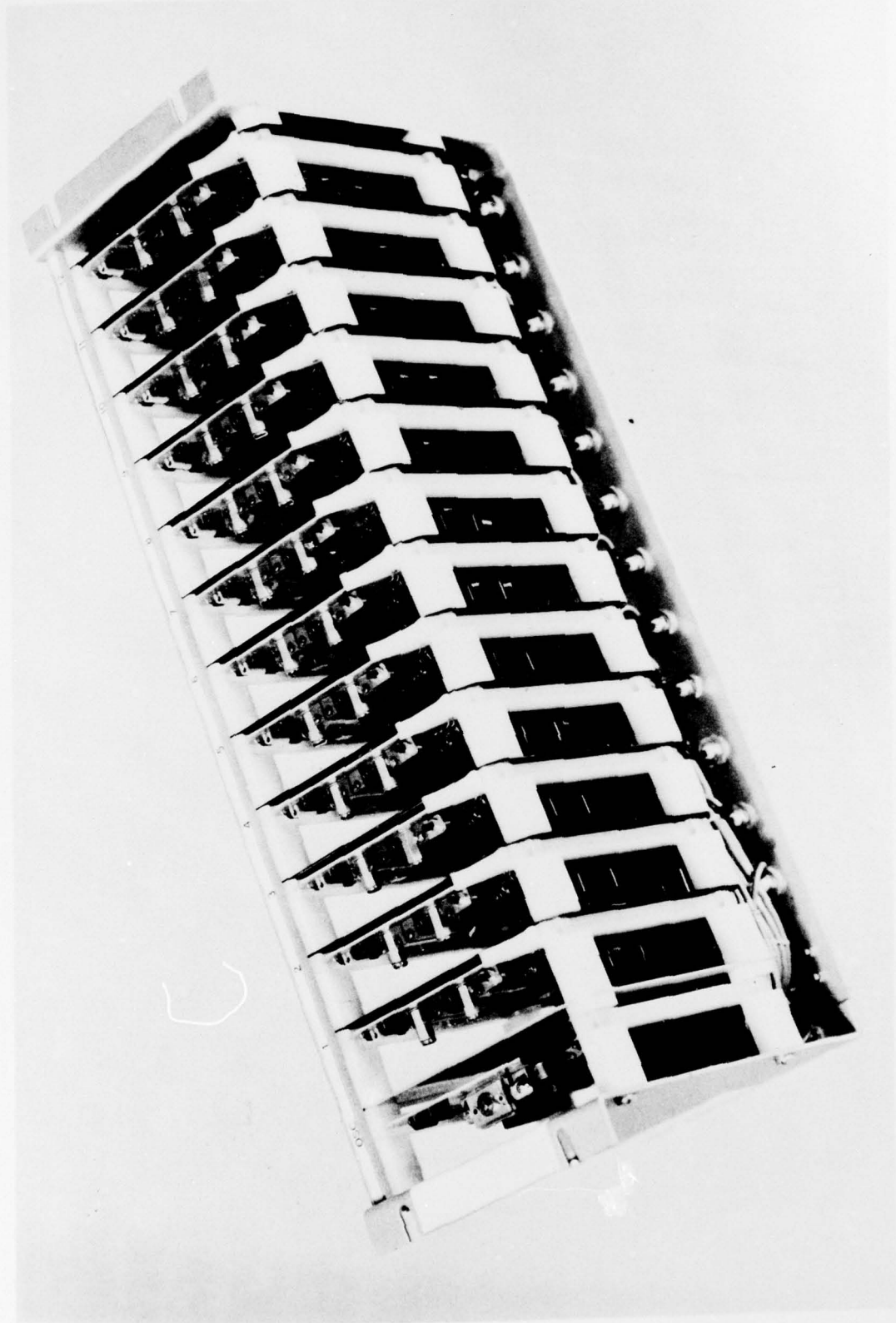

Figure 1 Card cage, front view.

Figure 2 Card cage, rear view

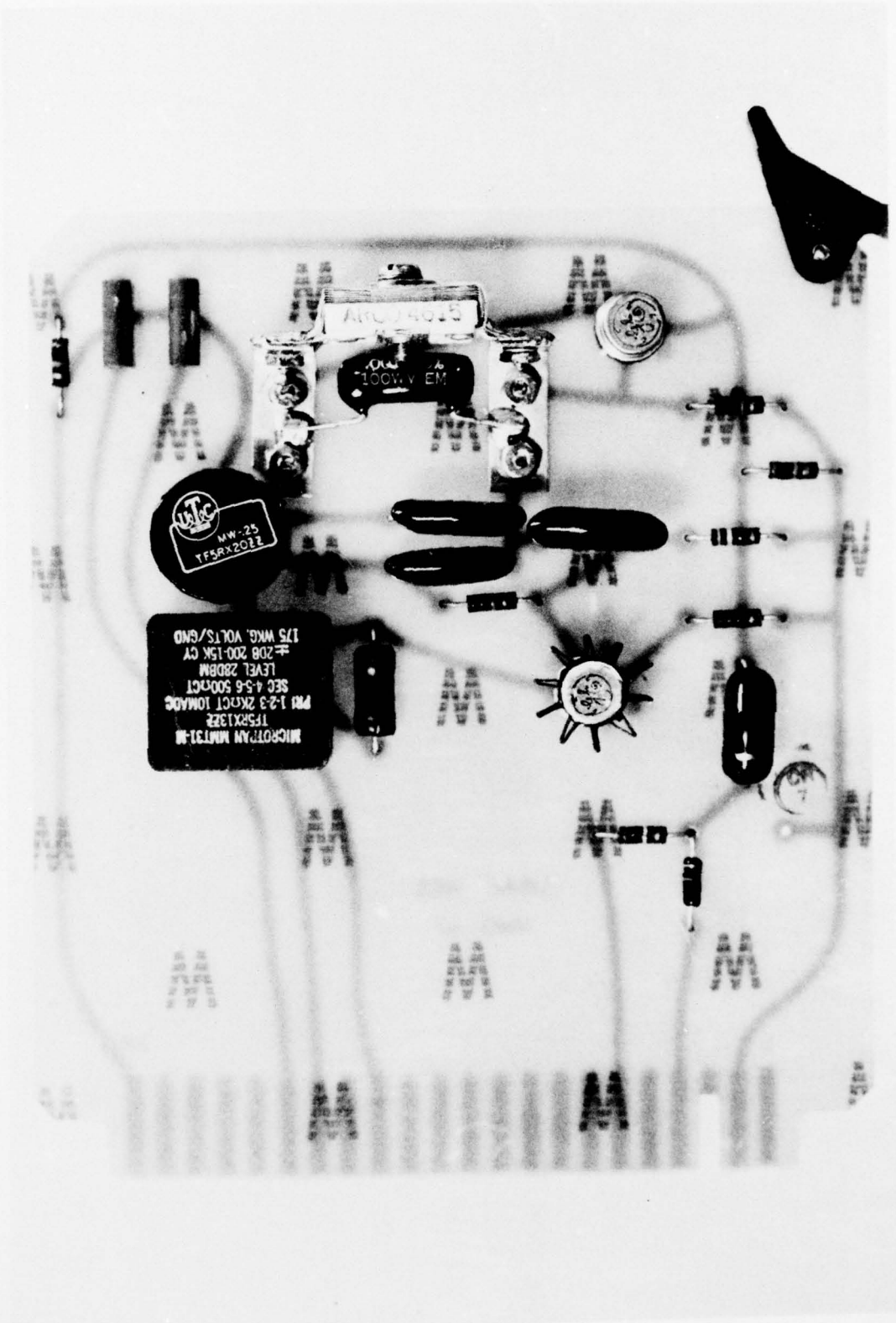

Figure 3 Oscillator circuit board

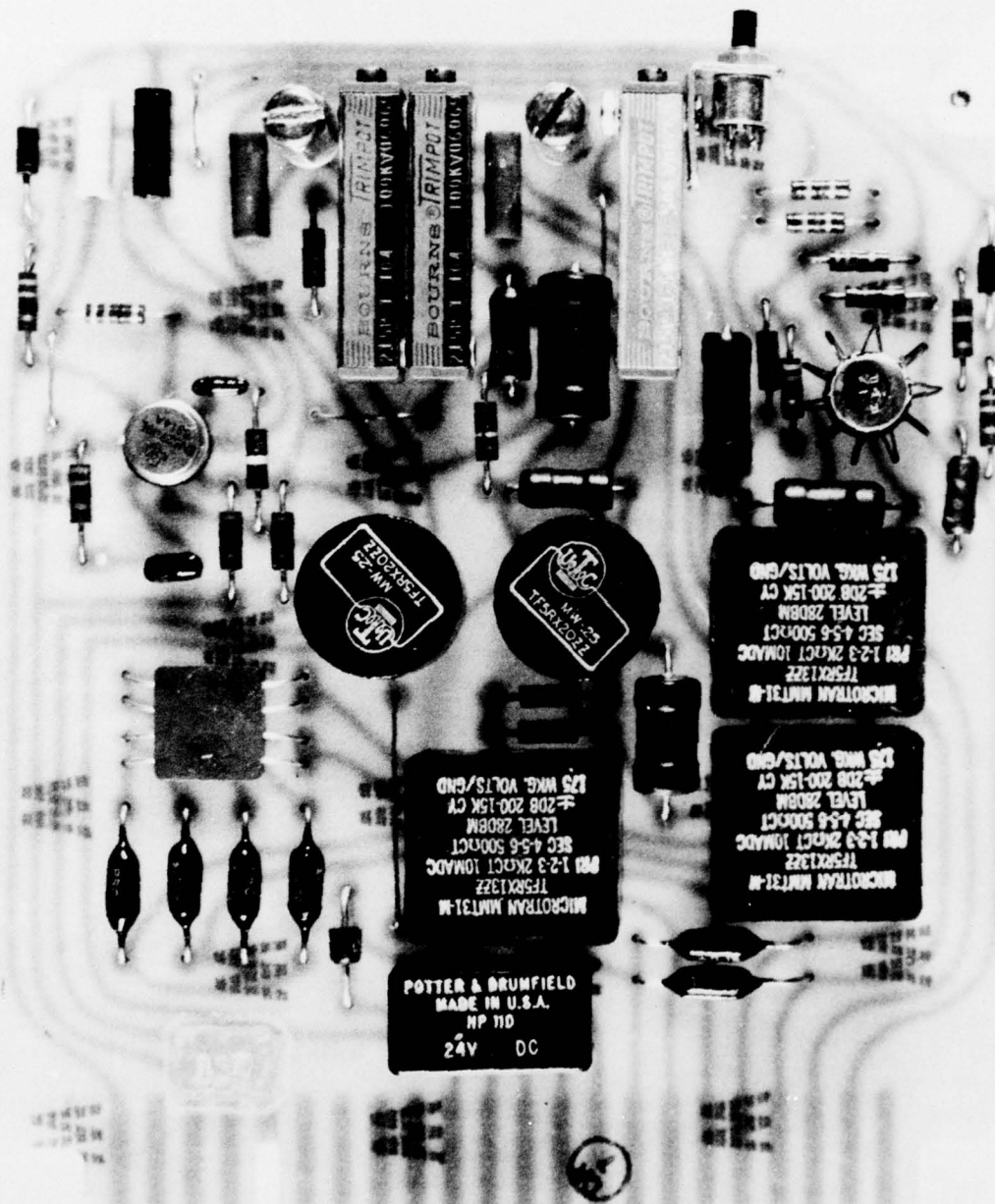

Figure 5 Signal conditioner circuit board

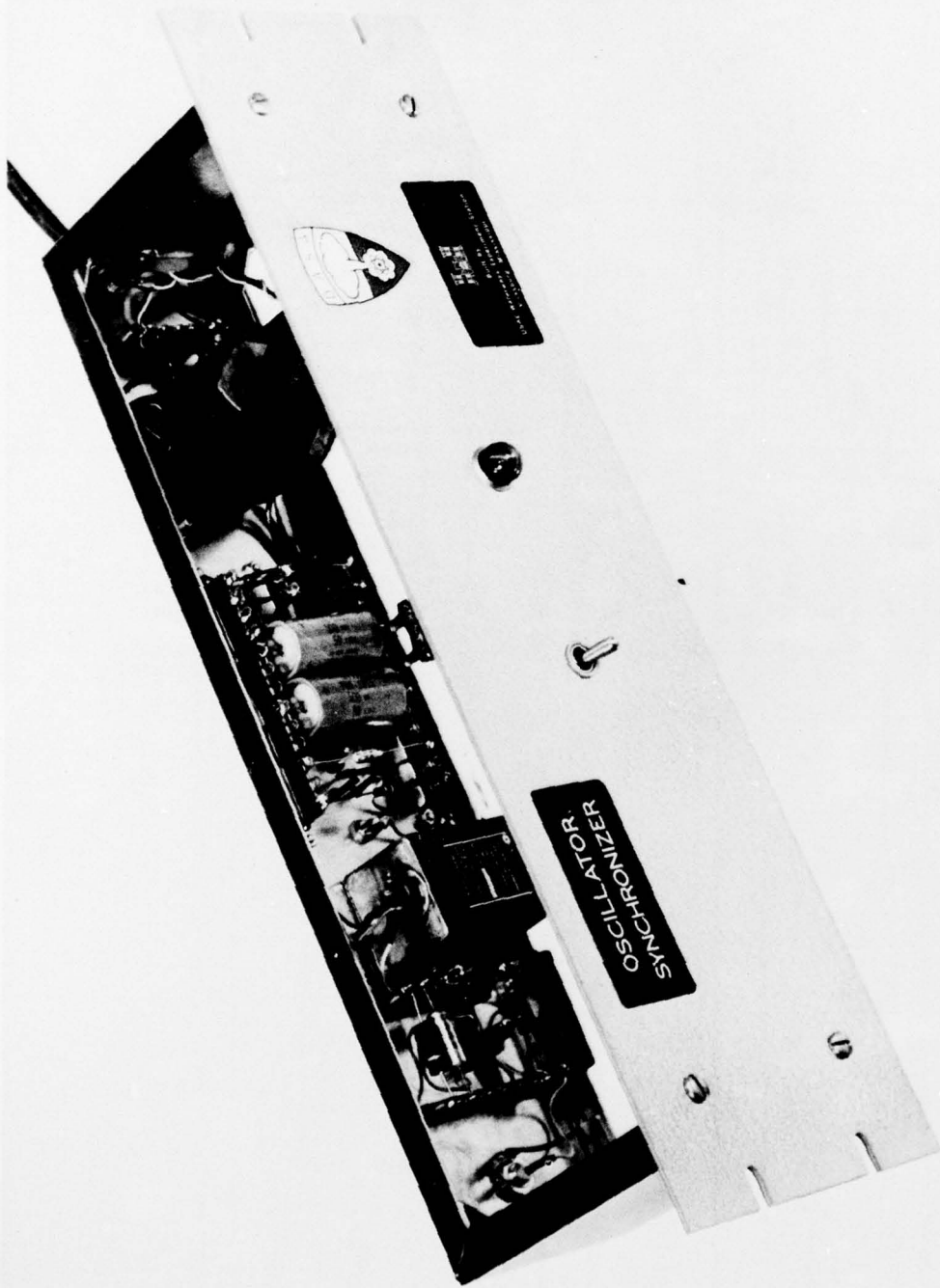
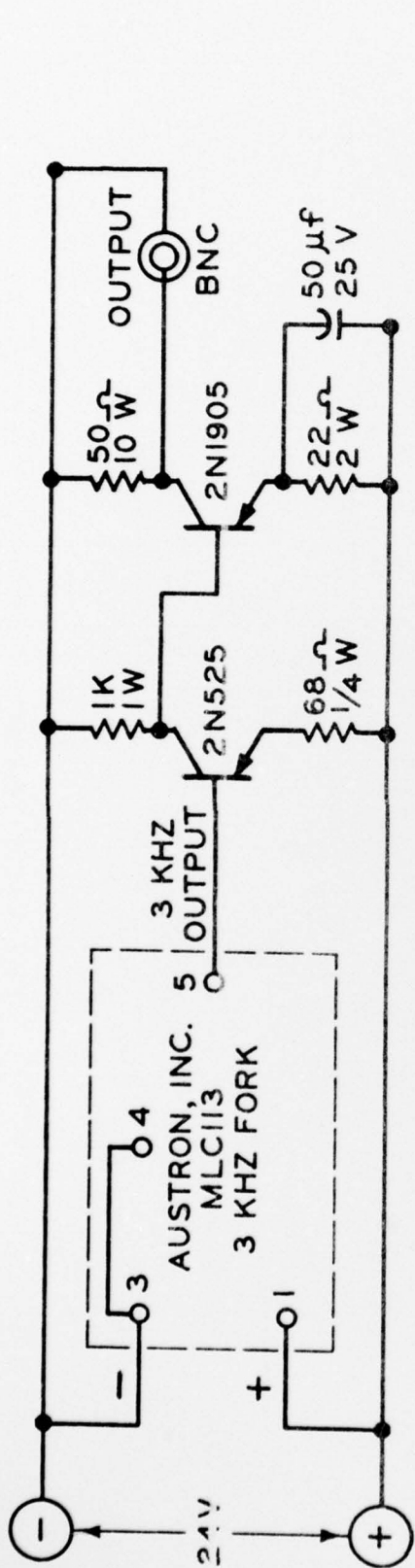
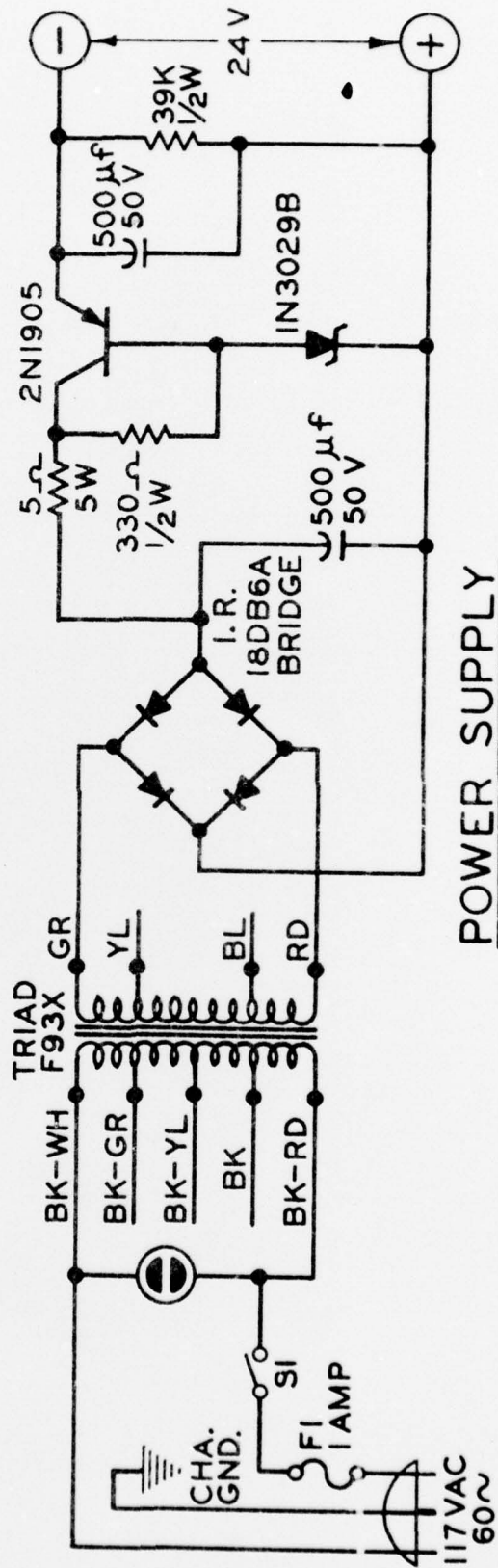

Figure 7 Oscillator synchronizer



SYNCHRONIZER



POWER SUPPLY

Figure 8 Oscillator synchronizer circuit diagram

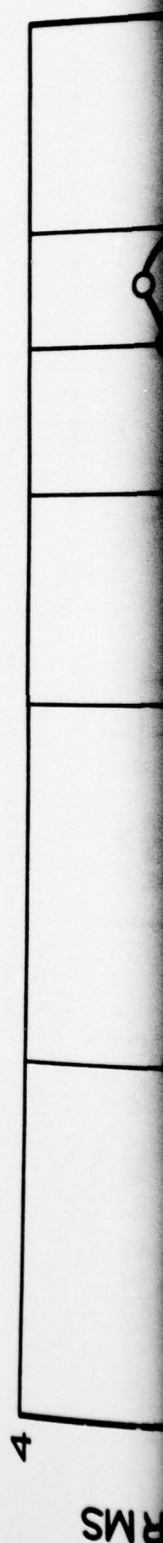

RMS

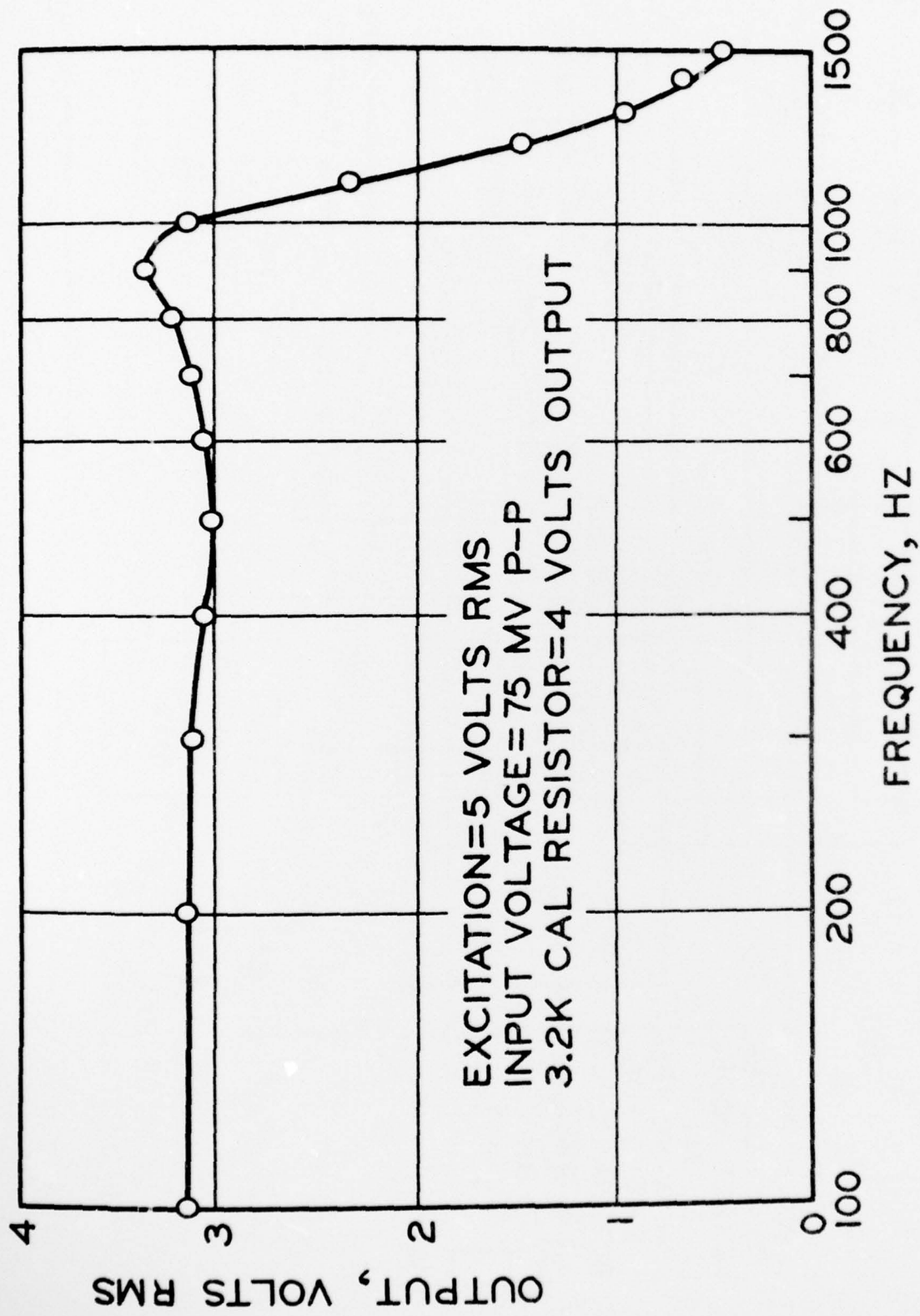

Figure 9 Sinusoidal frequency response

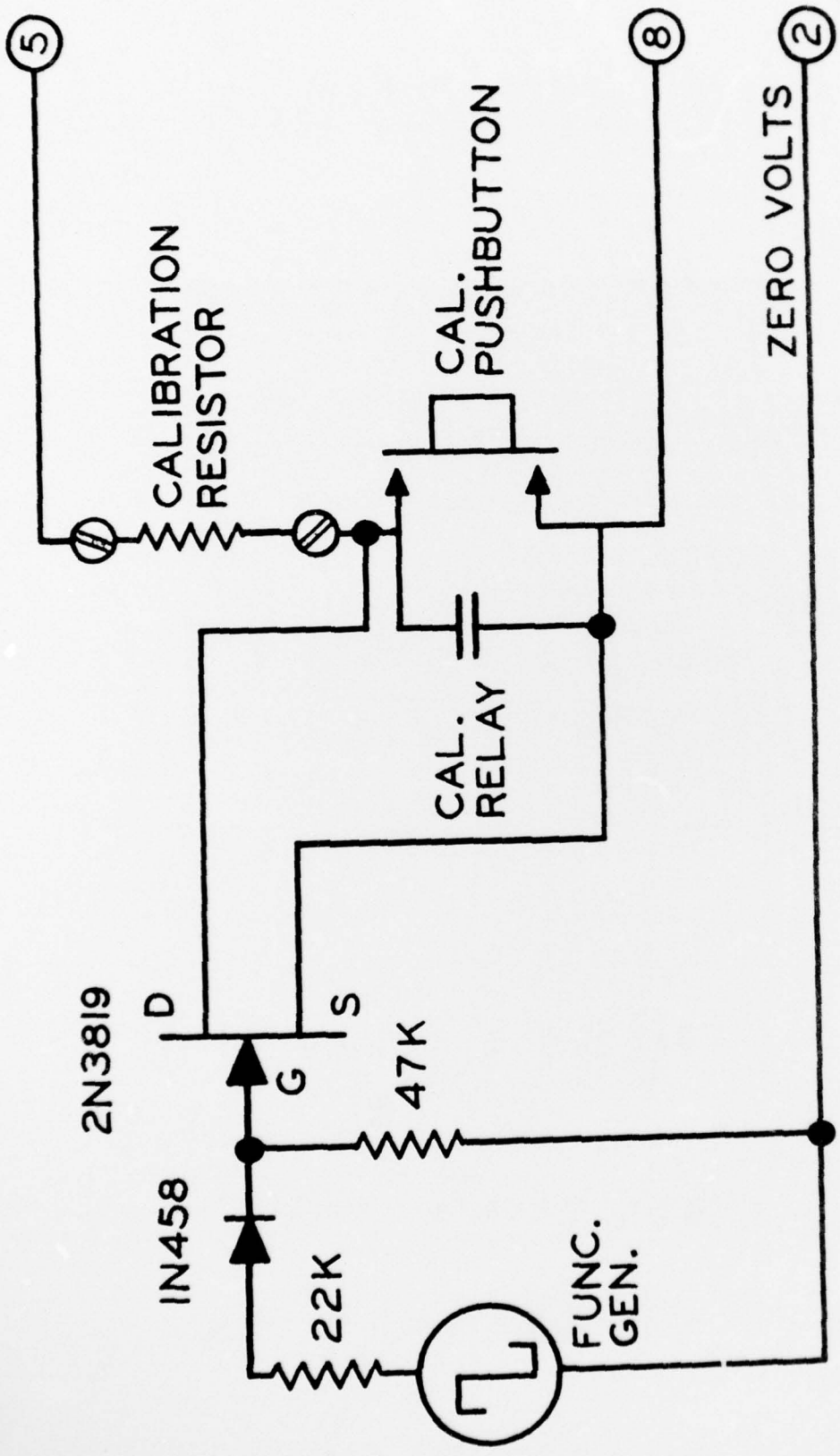

Figure 11 Field effect transistor modulator



SCALE: Vertical 1 volt/cm
Horizontal 1 msec/cm

Figure 12 Response to step input

Upper trace: Signal conditioner output

Lower trace: Accelerometer output

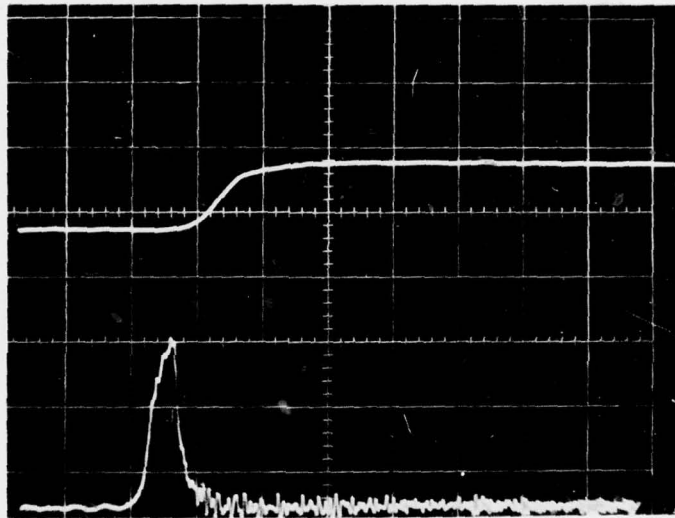

SCALE: Upper trace

Vertical 1 volt/cm
Horizontal 1 msec/cm

Lower trace

Vertical 200 mv/cm
Horizontal 1 msec/cm

Figure 13 Drop tower tests, acceleration and velocity

69638

Upper trace: 3 kHz carrier
Lower trace: Signal conditioner output

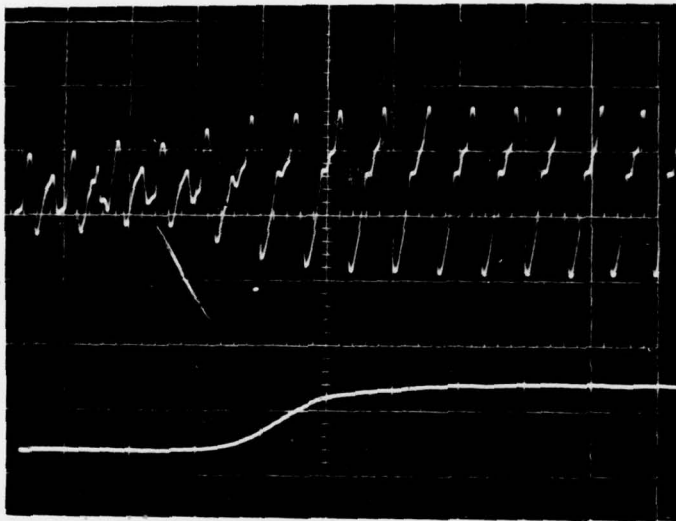

| | | | |
|--------|-------------|------------|-------------|
| SCALE: | Upper trace | Vertical | 500 mv/cm |
| | | Horizontal | 0.5 msec/cm |
| | Lower trace | Vertical | 1 volt/cm |
| | | Horizontal | 0.5 msec/cm |

Figure 14 Drop tower tests, system input vs output