

AD-A044 401

IMAGE GRAPHICS INC FAIRFIELD CT
CARTOGRAPHIC ELECTRON BEAM RECORDER (EBR) SYSTEM.(U)
AUG 77 P F GROSSO, A A TARNOWSKI

F/G 8/2

UNCLASSIFIED

ETL-0111

DAA653-75-C-0221

NL

AD
A044401

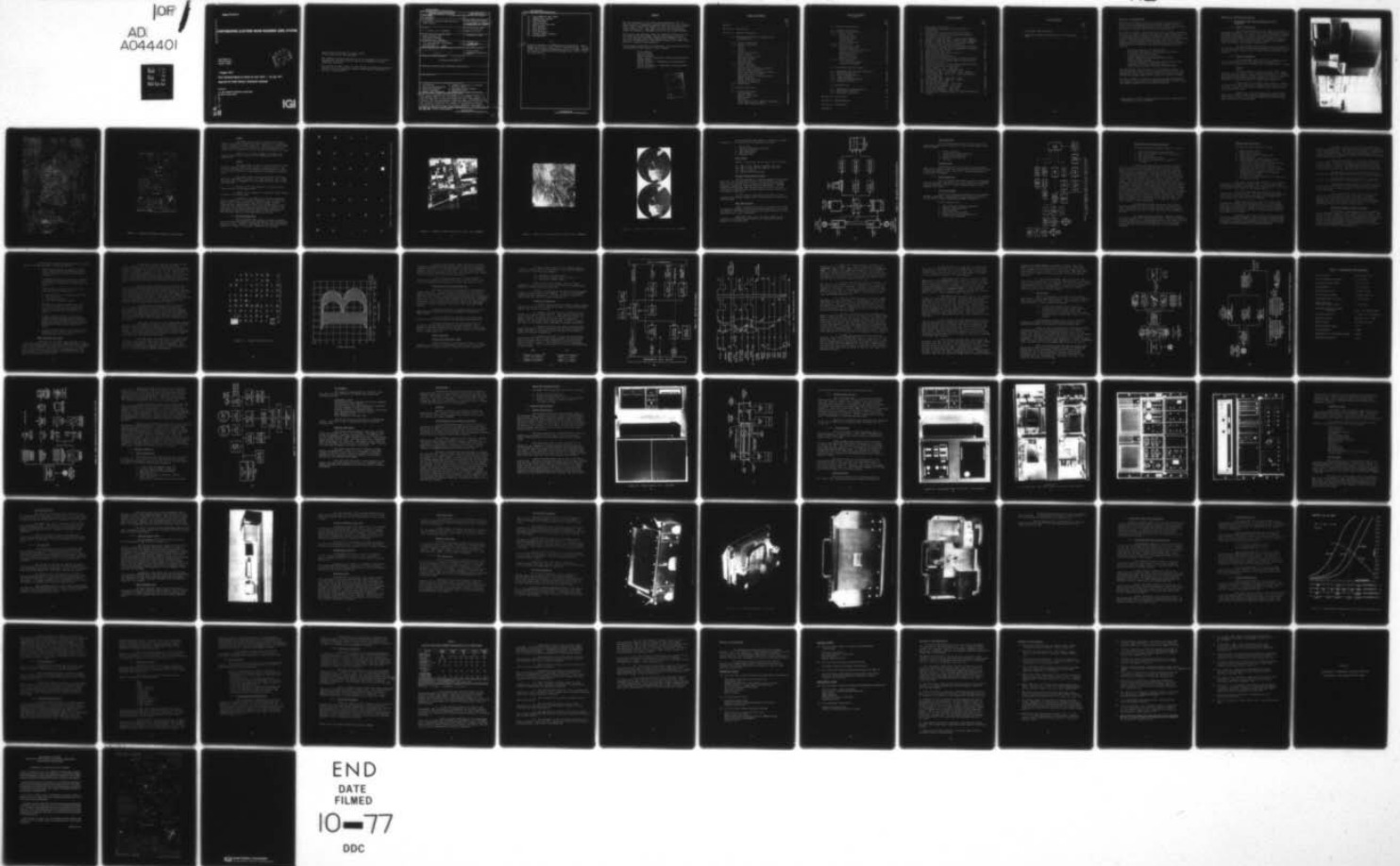

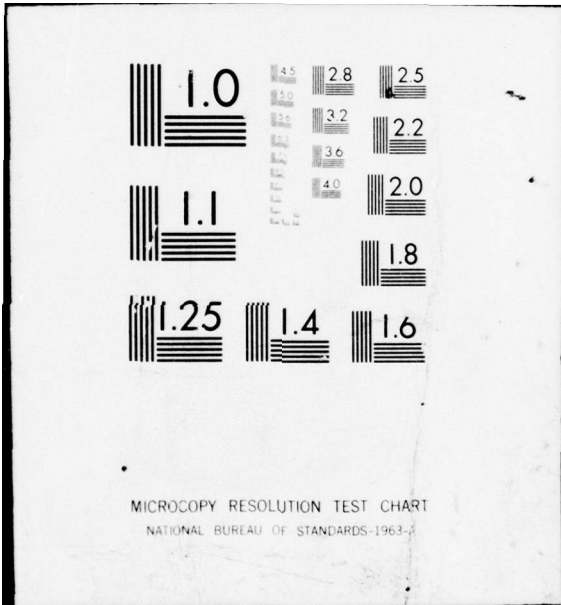

Report ETL-0111

12
B.S.

AD A 044401

CARTOGRAPHIC ELECTRON BEAM RECORDER (EBR) SYSTEM

Image Graphics, Inc.
1525 Kings Highway
Fairfield, Ct. 06430

DDC
SEP 21 1977
RECEIVED
C

1 August 1977

Final Technical Report for Period 16 June 1975 — 16 July 1977

Approved for Public Release; Distribution Unlimited

Prepared for

U.S. ARMY ENGINEER TOPOGRAPHIC LABORATORIES
Fort Belvoir, Virginia 22060

AD NG.
DDC FILE COPY



Destroy this report when no longer needed.
Do not return it to the originator.

The findings in this report are not to be construed as an official Department of the Army position unless so designated by other authorized documents.

The citation in this report of trade names of commercially available products does not constitute official endorsement or approval of the use of such products.

Unclassified

SECURITY CLASSIFICATION OF THIS PAGE(When Data Entered)

19.

11. Input Magnetic Data Tapes
12. Digital Font Library
13. EBR Performance
14. Input Section
15. Central Processor Unit
16. Mass Storage
17. Data Translator
18. Recorder Unit
19. Film Transports
20. Computer Output Graphics
21. Micrographics

20.

cont. → geometric fidelity of 0.03% have been demonstrated. Image format sizes were 5" x 8", 4" x 6", 70 mm and 35 mm. 32 line widths can be varied automatically from 6 to 250 μ m. Graphic arts quality characters can be recorded from 4 pts to 36 pts (at full scale).

inch →
micrometer →

Unclassified

SECURITY CLASSIFICATION OF THIS PAGE(When Data Entered)

PREFACE

The work described in this report was authorized by the U.S. Army [Engineer & Topographic Laboratories] Fort Belvoir, Virginia, 22060, under contract No. DAAG53-75-C-0221 and was conducted by Image Graphics, Inc. (IGI) under the direction of Patrick F. Grosso with Andrew A. Tarnowski serving as the Program Manager.

The contract was performed under the technical direction of the Automated Cartography Branch, Mapping Developments Division, U.S. Army Engineer Topographic Laboratories (USAETL) under the direction of Howard Carr. Fred Merkel served as the Contracting Officer's Technical Representative.

The following individuals and consultants at IGI made significant contributions to the success of this program.

Brian Anderson
John Breslawski
Eugene Gostomski
Robert Joseph - Consultant, Raster Scan Translator
George Krampetz
Michael Ostrellich - Consultant, Film Transports
John E. Turek
Clayton A. Washburn - Consultant, Electron Optics
John P. Whitley

APPROVED FOR	
WRITE SECTION	<input checked="" type="checkbox"/>
BUFF SECTION	<input type="checkbox"/>
REVISIONS	<input type="checkbox"/>
BY	
DISTRIBUTION/AVAILABILITY CODES	
SPECIAL	
A	

TABLE OF CONTENTS

	<u>Page No.</u>
Preface	iii
Section 1.0 Introduction	1
Section 2.0 Technical Discussion	2
2.1 Cartographic EBR System Configuration and Operation	2
2.1.1 General Description	2
2.1.2 Modes of Operation	2
Vector	2
Symbol	6
Raster	6
2.1.3 System Configuration	6
Input Section	11
Central Processor Unit	11
Mass Data Storage	11
Data Translator	13
Recorder Unit	13
2.1.4 System Operation	13
Vector and Symbol	13
High Resolution Graphics Generator	15
Digital Symbol Generator	16
Vector and Symbol Generator Software	17
Data Tapes and Font Tapes	18
Random Access X-Y Positioning Unit	22
Raster Scanning	22
Raster Scan Translator	22
Sequence of Operation	23
2.1.5 Applications	28
2.2 Computer Controller	33
2.2.1 System Description	33
CPU and Memory	35
Magnetic Tape Units	35
Disk Storage	36
Teletype	36
Direct Memory Access (DR11B) Interfaces	36
Adage 100B Storage Display	37

TABLE OF CONTENTS
(con't)

	<u>Page</u> <u>No.</u>
2.3 Electron Beam Recorder	37
2.3.1 General Description	37
2.3.2 Technical Description	40
2.3.2.1 Vacuum System.	40
Diffusion Pumps.	40
Mechanical Pumps	45
Vacuum Gauges	45
Fail Safe Features	46
2.3.2.2 Electron Gun	46
2.3.2.3 Electron Optic Coils	47
Beam Alignment Yoke	47
Static and Dynamic Focus Coil.	49
Astigmatism Corrector.	49
Deflection Yoke.	49
Spot Wobble Yoke	50
Magnetic Shielding	50
2.3.2.4 Film Transports.	50
5½ inch Film Transport	51
35 mm Film Transport	51
2.4 Cartographic EBR Performance	57
2.4.1 Recording Spot Size and Resolution	57
2.4.2 Beam Addressability.	58
2.4.3 Dynamic Range/Density.	58
2.4.4 Video Bandwidth.	60
2.4.5 Positional Repeatability	60
2.4.6 Geometric Fidelity	61
2.5 Recording Film	62
2.5.1 Sensitometric Characteristic	62
2.5.2 Dimensional Stability.	63
2.5.3 Positional Stability	63
Section 3.0 Conclusions.	67
Section 4.0 Recommendations.	69
Section 5.0 Bibliography	70
Appendix A	73

LIST OF FIGURES

	<u>Page</u> <u>No.</u>
1. Cartographic EBR System	3
2. Enlargement of Contours & Grids Plotted in Vector Mode	4
3. Aviation FLIP Chart Recorded in Vector Mode	5
4. Enlargement of Graphic Arts Quality Characters Recorded in Symbols Mode	7
5. Example of Image Recorded in Raster Mode (AERIAL)	8
6. Example of Image Recorded in Raster Mode (LANDSAT).	9
7. Example of Image Recorded in Raster Mode (RADAR).	10
8. Cartographic EBR System Configuration	12
9. Block Diagram of High Resolution Graphics Generator and Digital Symbol/Character Generator Subsystems.	14
10. Century School Book Font	20
11. Eighteen Point Upper Case Letter B.	21
12. Basic RST Block Diagram	24
13. Basic Timing Diagram for RST.	25
14. Application of Cartographic EBR for Map Production	29
15. Application of Cartographic EBR for Aviation FLIP Chart Production	30
16. Other Applications for the Cartographic EBR System.	32
17. Computer Controller Configuration	34
18. Image Graphics, Inc. - EBR 2000	38
19. Schematic Layout of Cartographic EBR	39
20. Cartographic EBR - Front View - Doors Removed	41
21. Cartographic EBR - Rear View - Doors & Mechanical Pumps Removed	42
22. Cartographic EBR - Upper Bay - Left	43
23. Cartographic EBR - Upper Bay - Right.	44
24. Electron Optics Column	48
25. 5½ Inch Film Transport - Front View	52
26. 5½ Inch Film Transport - Rear View	53
27. 35 mm Film Transport - Front View	54
28. 35 mm Film Transport - Rear View	55
29. Sensitometric Characteristics of Electron Sensitive Films.	59

LIST OF TABLES

	<u>Page</u> <u>No.</u>
1. Cartographic EBR Performance	31
2. Dimensional Change Characteristics of the Recording Film	64

Section 1.0 Introduction

During the last several years the Automated Cartography Branch (ACB), Mapping Developments Division (MDD), USAETL, at Fort Belvoir has been investigating the use of electron beam recording techniques to further the automation of map production.

The present contract, reported on herein, was to design, fabricate, and test an advanced Electron Beam Recorder (EBR) intended for use in making map color separations negatives and positives, which could subsequently be processed into full scale maps of cartographic quality. The Cartographic EBR developed under this contract demonstrated the feasibility of recording and plotting a number of representative cartographic and other micrographics products, such as:

- .Individual Minimap color separations*
- .Continuous tone imagery from satellite and aerial reconnaissance sensors data
- .Graphic arts quality textual data
- .Flight Information Publications (FLIP) Charts
- .Simulated Radar Imagery
- .Computer generated micrographics such as engineering drawings, scientific charts and graphs
- .High resolution image processing and enhancement

The Cartographic EBR was shown to be an extremely versatile, high performance electronic recording and plotting system. Its performance levels with regard to resolution, accuracy, repeatability and dynamic range, permit "state of the art" recording.

The ACB at USAETL is presently conducting further experimental investigation in the use of the Cartographic EBR to record various new computer generated map and graphics products.

*Input magnetic tapes for generating all the color separations of a Minimap are not yet available.

Section 2.0 Technical Discussion

2.1 Cartographic EBR System Configuration and Operation

2.1.1 General Description

The Cartographic EBR developed under this contract and shown in Figure 1, is a stand-alone, high performance electronic recording system which is capable of precision plotting (recording) high resolution imagery on various electron sensitive media. It is ideally suited for automated production of computer generated maps; recording of high resolution sensor imagery; and numerous other high quality micrographics applications.

The Cartographic EBR has several modes of operation which enables the user to evaluate experimentally the EBR technology for the automated production of a variety of existing and new map products.

2.1.2 Modes of Operation

The Cartographic EBR System may be operated in any one or combinations of the following ways to produce maps or pictures of various sizes or formats up to a maximum of 8 x 5 inches.

Vector

The Vector Mode is used for plotting lines, grids, contours, rivers, streams, roads, stroke characters, etc. Vectors are plotted incrementally (adjacent points) in either a "starburst" mode which allows single or double increments in any one of 8 directions or single increments in a Δx or Δy direction.

Line widths are selectable from 6 microns (.00025") to 250 microns (.010") wide using a standard electron gun or from 3 microns (.00012") to 90 microns (.0036") using a special high resolution electron gun.

Figure 2 is a typical example of a contour sheet and a grid overlay recorded with the Cartographic EBR using the Vector Mode. Figure 3 is a typical example of an Aviation FLIP chart recorded in the Vector Mode.



Figure 1. Cartographic EBR System

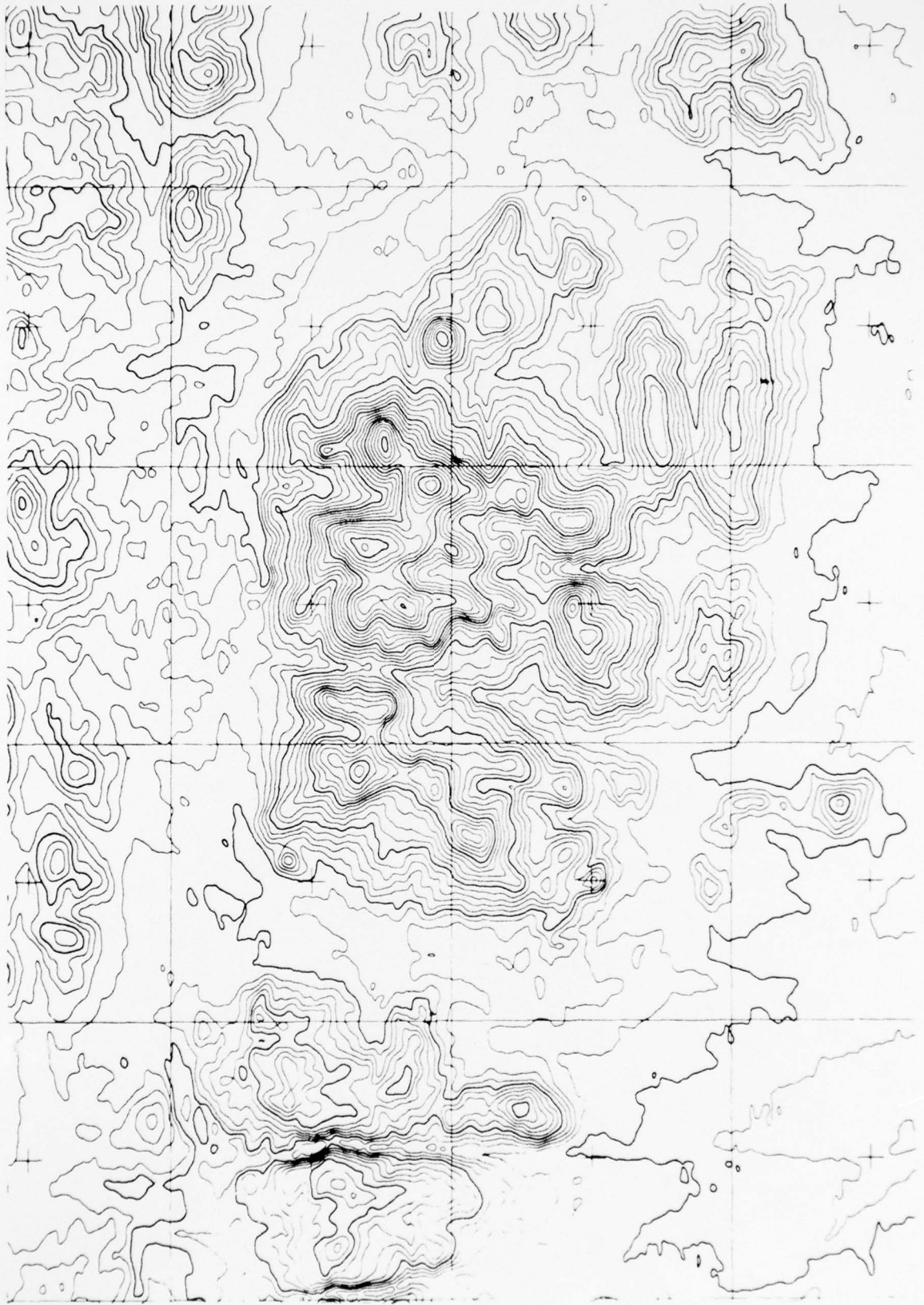

Figure 2. Enlargement of Contours & Grids Plotted in Vector Mode

Symbol

The Symbol Mode is used to compose and record graphic arts quality symbols for names sheets, text or symbology using a randomly positioned subraster. Character or symbol sizes can be varied from 5 to 36 points (at final product scale) and rotated in 1° increments to follow "serpentine" features of a map.

Figure 4 is a typical example of graphic arts quality characters recorded with the Cartographic EBR in the Symbol Mode.

Raster

The Raster Mode is used to record raster scan data or sensor imagery using either digital or analog rasters. The digital raster data may be incrementally recorded point by point or run length encoded for data compression and higher throughput rates.

The analog raster has four selectable scan rates which are individually variable up to 2000 scans per sec. Image recording time is dependent upon scan rate selected, image format and input data.

Figures 5 and 6 are examples of high resolution images recorded in the Raster Mode.

Figure 7 is an example of a digitized radar display recorded in the Raster Mode.

In addition, the EBR has two internal Diagnostic Modes of Operation to (a) record calibration test patterns that can be used to measure resolution, density range, transfer characteristics and geometric fidelity of the EBR and (b), scan a special test target located in the film plane outside of the image area of the 5½ inch transport and display an image of the **test** target on the CRT monitor in order to check positional accuracy and stability of the EBR deflection system.

2.1.3 System Configuration

The Cartographic EBR System is normally operated as an off-line stand-alone system using digital data from magnetic tape as an input. However, the EBR may be also used on-line with computers or sensors if suitable interfaces are provided.

H	I	J	K	L	M	N
T	U	V	W	X	Y	Z
	a	b	c	d	e	f
l	m	n	o	p	q	r
x	y	z				

Figure 4. Enlargement of Graphic Arts Quality Characters Recorded in Symbols Mode

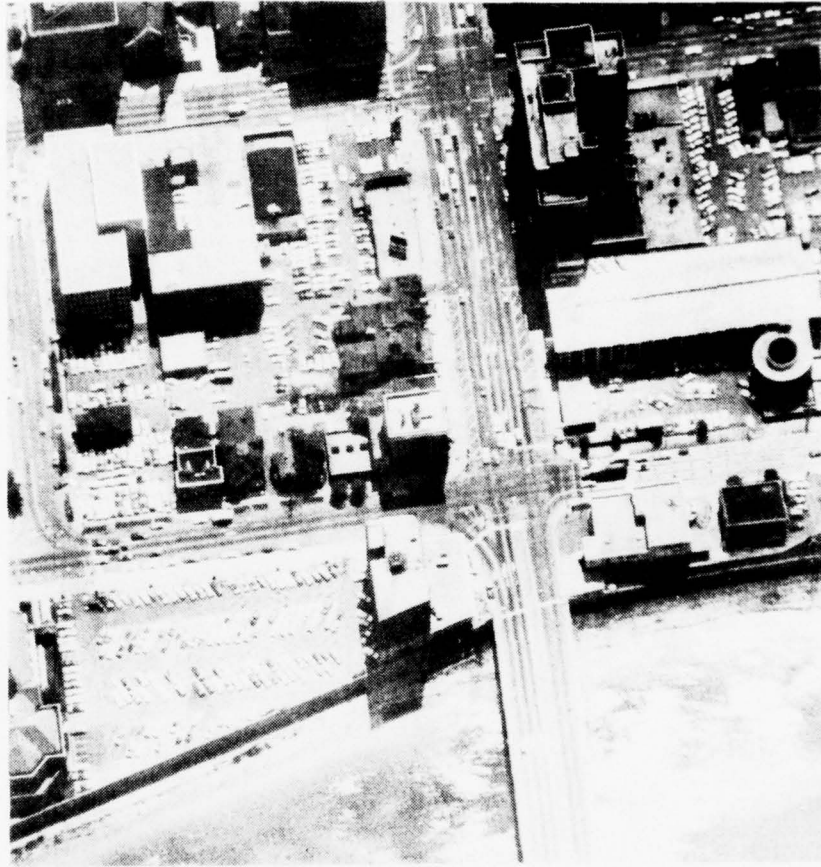

Figure 5. Example of Image Recorded in Raster Mode (AERIAL)

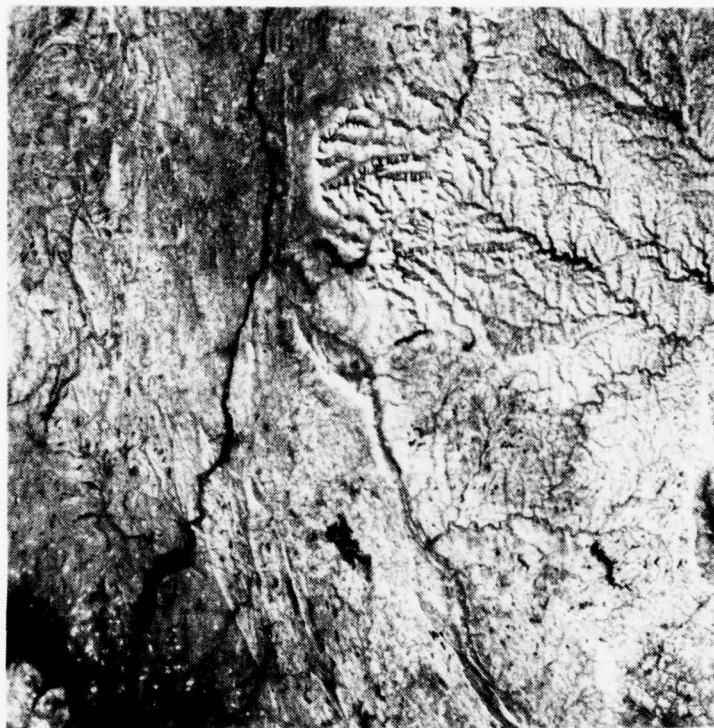

Figure 6. Example of Image Recorded in Raster Mode (LANDSAT)



Figure 7. Example of Images Recorded in Raster Mode (RADAR)

The Cartographic EBR System is configured as shown in Figure 8. It consists of five functional sections:

1. Input Units
2. Central Processing Unit (CPU)
3. Mass Data Storage
4. Data Translator
5. Recorder Unit

Input Units

Inputs to the system are via any of the following:

- (a) DEC 7 track, 800 bpi magnetic tape unit
- (b) DEC 9 track, 800 bpi magnetic tape unit
- (c) ASR 33 teletype
- (d) Adage Terminal Keyboard

Central Processing Unit (CPU)

The CPU provided is a Digital Equipment Corporation (DEC) PDP 11/05 minicomputer which is a basic binary processor with a 16 bit word and 32K of parity core memory with extended arithmetic capability (hardware multiply and divide). The CPU combines operating data and plotting instructions to the data translator to generate and position symbols, vectors, point plots or continuous tone data.

The CPU controls the digital data which is then converted into analog signals which in turn precisely control the electron beam.

Mass Data Storage

A DEC 1.2 million word disk is provided for storage of operating programs and digitized representations of type fonts and symbols. The disk can be used as an on-line library for fonts containing 100, 18 pt. characters.

Additional disks (up to 8) can be added to the controller to expand storage capacity for additional software programs or Font Libraries.

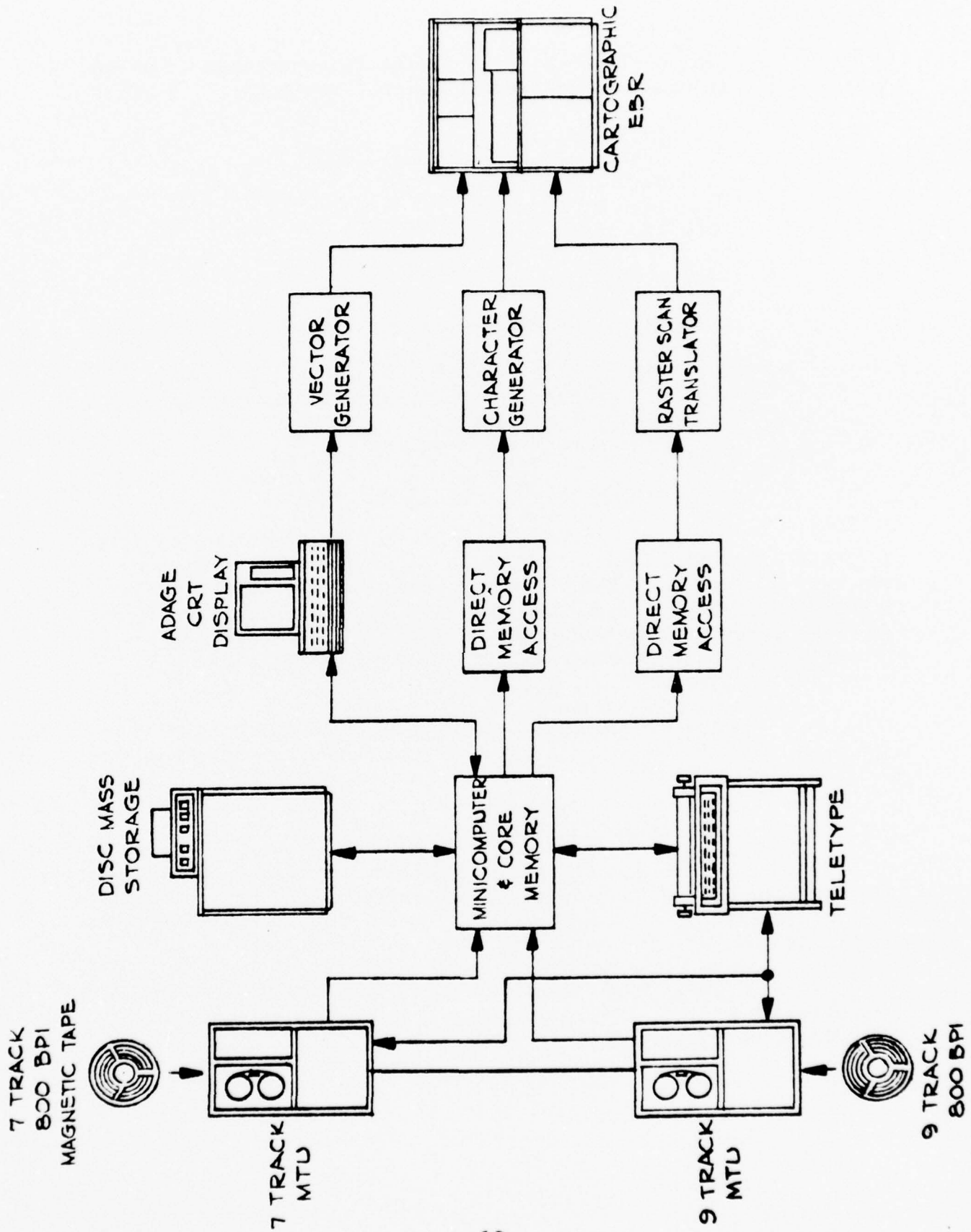

Figure 8. Cartographic EBR System Configuration

Data Translator

The following Data Translator Circuits of the Cartographic EBR convert digital data into analog signals which drive the EBR.

- a. Vector Generator
- b. Graphic Arts Symbol Generator
- c. Random Positioning Unit
- d. Raster Scan Translator
- e. Controls

Recorder Unit

The Recorder Unit is an electron beam recorder (EBR) which converts electrical signals into latent images directly on electron sensitive film. The film is then processed using conventional techniques.

2.1.4 System Operation

The Cartographic EBR System operation is dependent upon the recording mode and type of output image to be produced. As described above, there are three recording modes: vector, character and raster.

Vector and Symbol

Vectors and symbols are generated by two hardware/software subsystems: the High Resolution Graphics Generator and the Digital Symbol Generator as shown in Figure 9.

Major components are:

1. High Resolution Graphics Generator
2. Digital Symbol Generator
3. System Software
4. Data Tapes and Font Tapes
5. Random Access X-Y Positioning Unit
6. Electron Beam Recorder

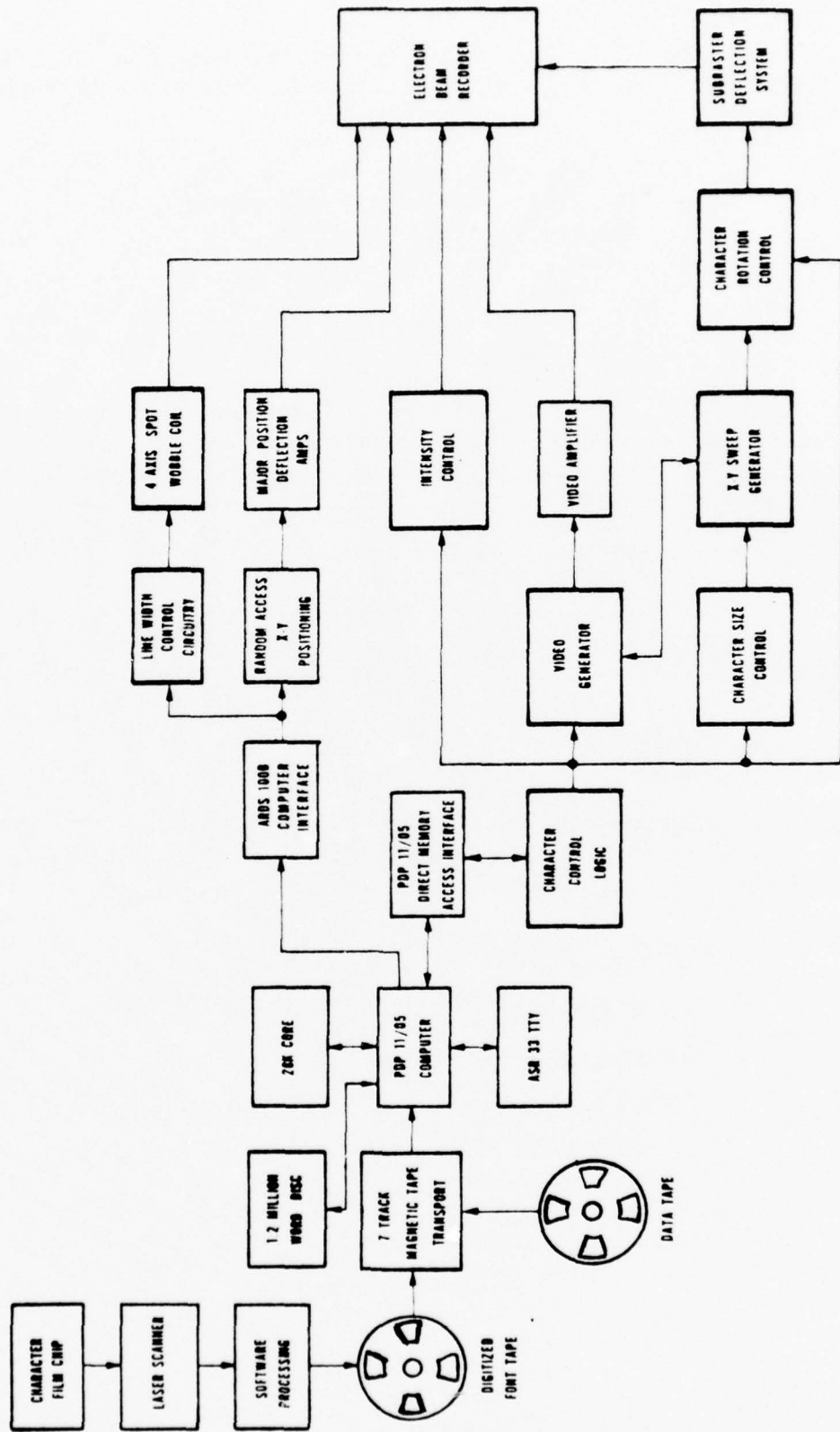

Figure 9. Block Diagram of High Resolution Graphics Generator and Digital Symbol/Character Generator Subsystems (15)

High Resolution Graphics Generator

The High Resolution Graphics Generator contains:

1. Seven-track Magnetic Tape Transport
2. PDP 11/05 Computer with 32K of Core Memory
3. ASR 33 Teletype
4. ARDS 100B Storage Display
5. Micromap System and Symbol Generation Software

Input to the high resolution graphics generator is in the form of computer-generated digital tapes with map data. The seven-track, 800 bits per inch, industry standard magnetic tape is read by the 45 inch per second DEC Model TU10 tape reader and transferred to the core memory of the DEC PDP 11/05 minicomputer controller. The ASR 33 teletype is employed to program the minicomputer with a variety of software routines and to control the selection of tape from the magnetic tape reader. The minicomputer computes the positioning and vector information from the raw digital data and transfers these signals to an Adage Corporation, Model ARDS 100B vector controller and interface. X-Y signals are introduced into the 32K x 32K random access beam positioning system in the EBR which provide over one billion addressable points for a single frame. Vector information in the form of absolute and delta digital numbers are converted into analog signals that drive the deflection amplifiers in the EBR to provide X and Y positioning of the electron beam. The graphics generator input subsystem to the EBR also provides write commands (z axis modulation).

An ARDS 100B storage cathode ray tube display with its keyboard is used to monitor the plotting beam and to review the digital data and software routines from the magnetic tape, and may also be used to select the data to be recorded by the EBR.

The operating system software commands, resident in the core memory after transfer from disc, control map generation and symbol generation. These commands instruct the logic circuitry in the high-resolution graphics generator to send the proper sequence of input signals to the EBR system for cartographic recording.

Digital Symbol Generator

The Digital Symbol Generator contains:

1. Symbol Control Logic
2. Symbol Video Generator
3. Electronic Scaling of Symbol Size
4. Symbol Rotation
5. Sweep Generation and Brightness Control
6. A Direct Memory Access Interface, to efficiently transfer data from the computer to the symbol generation hardware
7. A Disk System interfaced to the PDP 11/05 computer; the disk stores the font library
8. Expansion Chassis and Power Supply, to accommodate core memory, core used for limited font storage
9. Multiply and Divide Hardware, for computation of symbol location

The symbol control logic interfaces to the direct memory access channel in the PDP 11/05. It then directs and distributes the control information and digital symbol information to the other logic blocks in the symbol generator.

The symbol video generator develops the video representation of each symbol. The video information consists of on-off logic levels that literally trace out the symbol on a scan line by scan line basis on the EBR film.

Symbol point sizes 5, 6 and 7 are scaled from the digitized eight point font stored in core. Symbol point sizes 10, 12, 14 and 36 are scaled from the digitized eighteen-point font stored in core. Symbol size scaling is accomplished by changing the slope of the X and Y subraster sweep circuits that trace out the symbol.

Symbols in any point size can be rotated through 360° in one degree increments. Symbol rotation is accomplished by the use of circuits that multiply the X and Y subraster scan waveforms by appropriate trigonometric functions and the output waveforms obtained are added in a summing amplifier.

The X and Y sweep circuits are a ramp and a D/A converter, respectively. The sweep circuits trace out a subraster at the command position. The size of the subraster is proportional to the symbol point size. As the symbol size changes, a D/A converter generates a different analog voltage to maintain constant symbol intensity on film.

Twenty thousand words of core memory are used for symbol storage. Based on an average of 300 computer words per 18 point symbol, a total of 67 eighteen-point characters can be stored in core at any time. The remaining eight thousand words of core memory are used for program storage and for data storage.

The DMA channel serves as the interface between the PDP 11/05 and the symbol control logic in the symbol generator.

The expansion chassis and power supply are used to house core memory circuitry and provide power, respectively.

The multiply/divide hardware was added to the PDP 11/05 to allow calculation of symbol locations from information on the Font Tape at speeds commensurate with the speed of the symbol generator.

The cartridge disk system provides mass storage to hold 1.2 million words of symbol font data. Assuming an average font to contain 100 symbols, and that each symbol averages 300 words of storage, the disk will hold 40 different fonts on-line at one time. Since the disk packs are removable, additional fonts can be stored on other packs.

Vector and Symbol Generator Software

The software system operates with the standard, Digital Equipment Corporation disk operating system (DOS). This system includes a monitor, a relocatable assembler, an editor, a linker, an on-line debugger, and a peripheral interchange package. The DOS package permits easy start-up procedures for the EBR system, and most importantly, provides the basis for making extensions and modifications to the programs in the field after the system is installed and operational.

The following software packages utilizing the disk system are either available or under development.

1. Map handling programs to generate contours, roads, fields and streams and other cartographic information are being developed by U.S.A.E.T.L.
2. A command repertoire to provide for addition, verification and deletion of fonts to the font library on the disk was installed in the system.
3. Symbol handling programs to detect calls were installed in the system to:
 - a. Select font (i.e., load font into core)
 - b. Set point size
 - c. Set symbol rotation
 - d. Call for plotting of symbols
4. Routines for processing symbol plot calls to locate the symbol in the font data in core, or if not in core to retrieve the data from the disk were installed in the system.
5. A symbol location program to calculate a symbol's starting location based on bearing, kerning and width information in the font repertoire and point size and symbol rotation from the Data Tape was installed in the system.
6. A Century School Book font was digitized and installed in the system. Other fonts are being developed by U.S.A.E.T.L.

Data Tapes and Font Tapes

A Data Tape is a magnetic tape prepared for use on the EBR system, which calls out the commands needed to generate each of the cartographic map separation film chips. The commands stored as data files on this tape call out the type of symbol size, symbol position, symbol angle, and command codes to the minicomputer for computing positions of the plotting electron beam and variations in line width.

A Font Tape contains digitized scan data for one or more symbols. The only font tape currently available contains a character set composed of 84 characters in the Century Schoolbook typeface, as shown in Figure 10. The font was supplied to CBS Laboratories, Stamford, Ct., on a 70 mm x 100 mm film positive, and each character size was 12 points. The film format size is compatible with the input format requirements of CBS Laboratories Laser Image Processing System (LIPS), a laser scanner and recorder that was used to scan and digitize each character on film.

Using the LIPS, each character on the type font film was digitized and the data placed on magnetic tape. As shown in Figure 11, the digitization process consists of scanning the character in the vertical direction (drum rotation on the LIPS) and incrementing the scan lines from left to right (moving the laser beam parallel to the drum). Video data are clocked into the LIPS core memory and then onto the magnetic tape at the desired elemental spacing for each scan axis. The actual digitizing process takes less than three minutes per character.

A twelve-point character on film is scanned by LIPS in the ten micrometer or 50 lp/mm mode, providing 416 scan elements in each scan direction, for use as the reference eighteen-point character for scaling in the character generator. Similarly, the eight-point reference character is generated from the twelve-point film character, using the twenty micrometer or 25 lp/mm mode of LIPS. This generates 208 scan elements in both directions.

Video data are stored on nine-channel NRZI magnetic tape in the form of eight bit density words (inherent in the LIPS design). Since a symbol is essentially black or white, the density words will be clusters of either low or high values of density. These small variations in density are further processed by computer to establish the video on and off addresses within every scan line that comprises the symbol.

The LIPS output tape consisting of a square raster of density words is processed to provide symbol identification and spacing information. The video data are converted into positional information representing video transitions. This data is then rewritten on magnetic tape in a form suitable for use by the system control software and hardware.













	^s e	^s E	^s y	^s Y	^s h	^s H				
	• 5	%	..	?	q	Q				
d	D	,	!	u	U	f	F	t	T	
.	.	6	¢	z	Z	x	X	v	V	
i	I	b	B	r	R	p	P	c	C	
k	K	7	&	;	:	'	‘	-	—	
o	O	w	W	m	M	g	G	s	S	
0)	9	(4	\$	j	J	1	fi	
	[]	l	L	n	N	a	A			
		3	#	8	*	2	/			

Figure 10. Century School Book Font

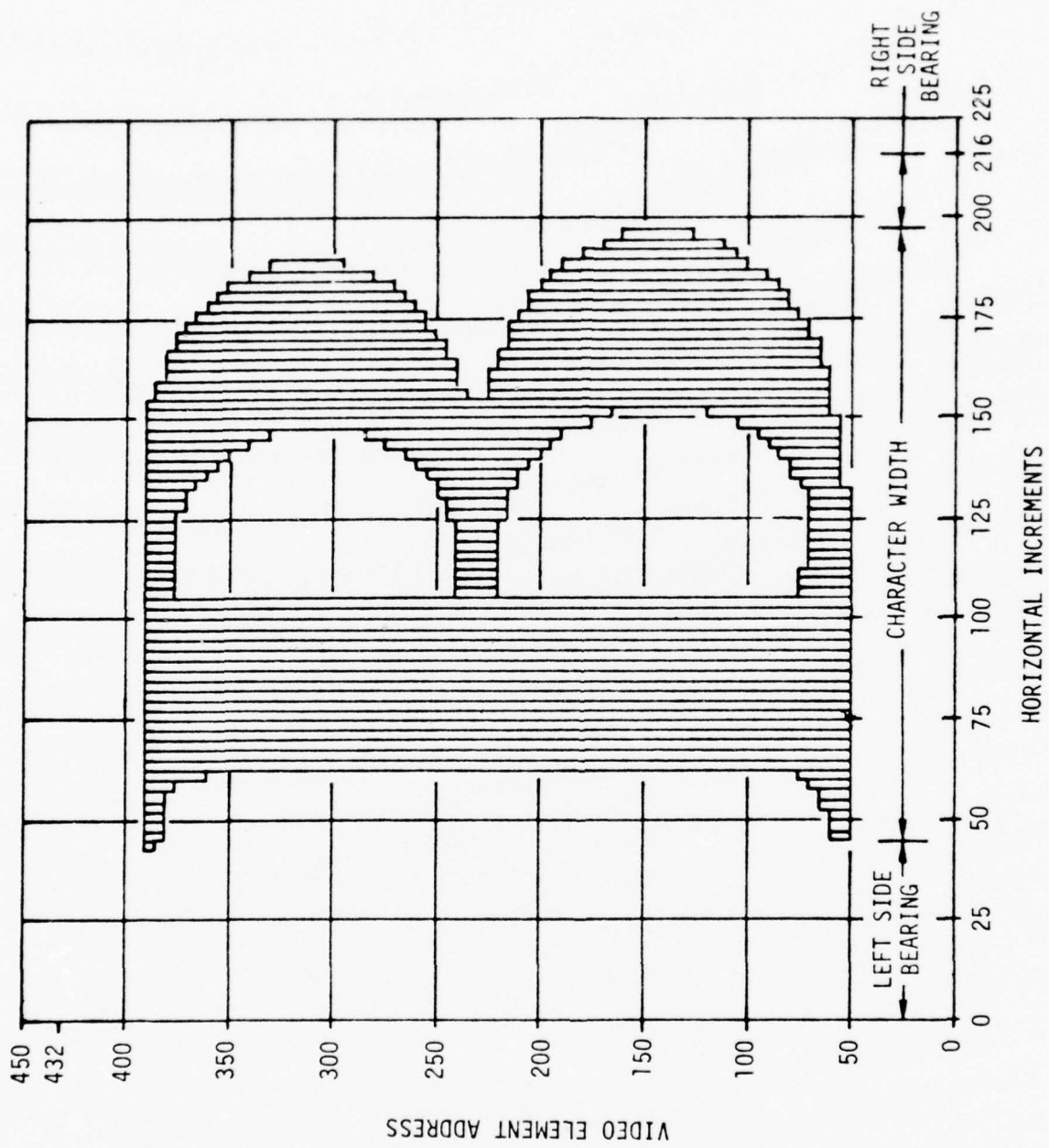

Figure 11. Eighteen Point Upper Case Letter B

Synecticis Corporation, Rome, New York; an information and software processing and analytical service organization, through a subcontract to CBS Laboratories, provided the necessary computer processing of the symbol data. The font tape resulting from the computer processing is a seven-track magnetic tape suitable for use with the PDP 11/05 computer controller.

It should be noted that any suitable scanning process may be used to digitize characters or symbols to be used in the Cartographic EBR System, (i.e. Laser, CRT, Optical, etc.).

Random Access X-Y Positioning Unit

The random access X-Y positioning unit accomplishes several functions. Its major task is to generate, from digital signals received, voltages to position the electron beam over the EBR output film format. Originally beam positioning was accomplished over a 32,768 x 32,768 matrix, providing over one billion addressable points for a single frame. More recently, 18 Bit digital to analog converters giving the possibility of over 250K x 250K addressable points in a single frame were installed in the Cartographic EBR System.

A second function is to interface directly to the ARDS 100B and distribute the received signals to appropriate logic blocks.

Its third function is to control the turn-on and turn-off of the electron beam in the EBR during map generation.

The final function of the random access unit is to control the starting and stopping of map generation and to signal the graphics generator when the EBR is ready to accept data. During a film advance interval, the graphics generator is signaled not to transmit new data.

Raster Scanning

Raster Scan Translator (RST)

Raster scanning in the Cartographic EBR is accomplished using the Raster Scan Translator (RST) channel which converts digital data on magnetic tape to a raster format for recording.

The data format required for recording images in a raster scanning mode is organized on 9 track, 800 bpi magnetic tape in one of the following manners:

- (a) Continuous tone gray scale
- (b) Sequential binary, black or white, or
- (c) Run length encoded binary

Details of the exact formats used for raster scanning are given in Volume III of the Operation and Maintenance Manual for the Cartographic EBR System.

The RST is interfaced to the PDP 11/05 mini-computer through a direct memory access (DR11B). A simple block diagram showing the major components of the RST is given in Figure 12. Basic timing for the RST is given in Figure 13.

Sequence of Operation

a. Program generates INIT via START or RESET command. Manual switches are set to indicate the mode of operation required and the film system to be used.

b. Operator activates run and when EBR interlock becomes true signals ATTN to DR11-B. Under program control via either interrupt (if IE was set) or a read SRST instruction, the control computer recognizes the request and interprets the DSTAT A, B, C lines which have been encoded (3 BITS) to signify the state of the manual control switches (8 possible selections).

c. Program checks that all other system elements (e.g. Tape Format) are in accordance with the manual request and either proceeds, or indicates an error message to the operator asking for operator intervention.

d. Assuming the error, if any, has been cleared, the program then begins to input data, reformat as required and store a complete line of video information in a special buffer zone in the PDP 11 memory. This information will be sequential words of either 2 bytes of grey scale or 16 bits of B/W information, as shown below:

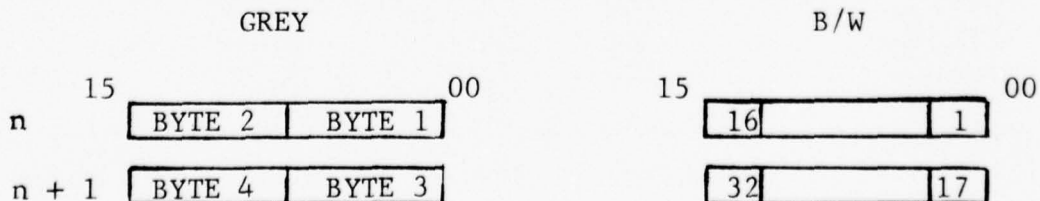

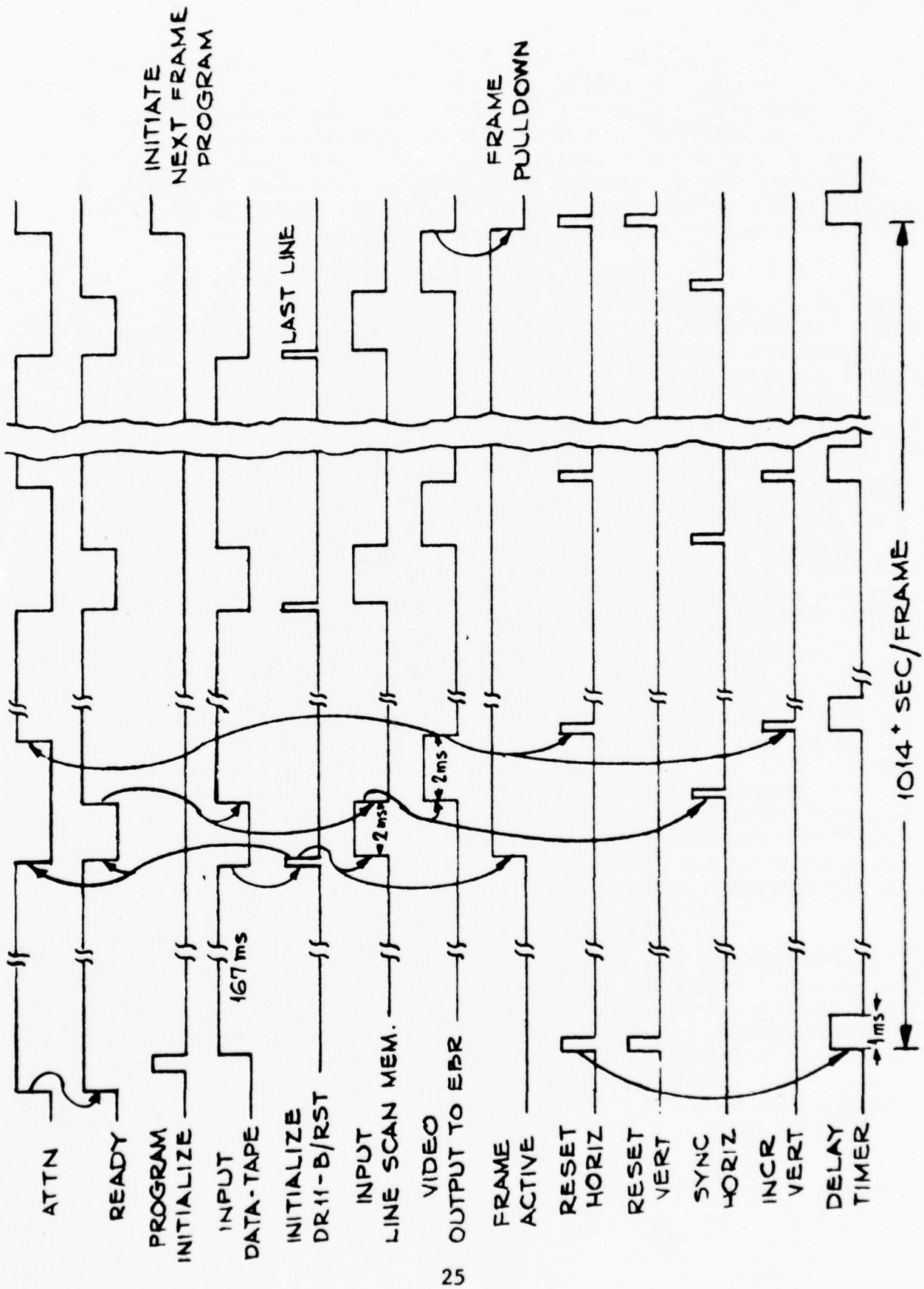

INITIATE
NEXT FRAME
PROGRAM

FRAME
PULLDOWN

LAST LINE

1014 * SEC/FRAME

Figure 13. Basic Timing Diagram for RST

e. When a full line of data is available, the program sets up the FNCT 1, 2, 3 bits to indicate line type (CONTINUE, LAST), format (GREY, B/W) recording mode (INCREMENTAL, RAMP). In addition, the DRWC and the DRBA are initialized to allow for the DMA offloading of the line data. Note that since the Raster Scan Translator (RST) gets no numerical indication of the numbers of data words to be transmitted, the DRWC overflow will be used to indicate last word in the line.

f. Program then sets GO active in the DRST. The RST utilizes this signal to read the function bits and set up the control sequences accordingly. The DR11-B drops READY and obtains bus mastership. The control sequence initiates a CYCLE RQST and upon receipt of an END CYCLE loads the first two bytes of line data into the line scan memory. In addition, the GO pulse sets FRAME ACTIVE to true.

g. After the first two bytes of data are loaded, the MAR of the line scan memory is incremented by 2 and another CYCLE RQST is generated followed by an END CYCLE and load data byte sequence. This operation continues until WCOF occurs in the DR11-B setting READY. READY going high causes the release of bus mastership, and in the RST the storing of the MAR in the Last Byte Address Register (LBAR).

h. The line scan memory is then converted from WRITE to READ, the MAR is reset to zero and a train of HORIZ INCR pulses is released at the max rate of 250 KHz. Coincident with these pulses the byte data are sequentially read from the line scan memory and clocked onto the video convertor D/A and output to the video amplifier. The video amplifier is held blanked for a short duration to eliminate D/A glitch outputs transients (if video amp can respond to them). If B/W format was selected, each byte would be sub-divided into its bits prior to input to the D/A, a "0" causing a 0 volt output and a "1" causing a 1 volt output.

i. If RAMP mode was selected, only one pulse would be output from the HORIZ SYNC line, to cause start of the horizontal ramp. The video output would be clocked out at a rate that is predetermined by the setting of the RATE selector switch and the format selected (GREY, B/W). Note that in GREY format the input data rate from the DR11-B is maximum at 2M bytes/second and any video output rate in excess of that will not result in additional thrupt.

In the B/W format the input rate of 16M bits/sec will allow for a maximum video rate of 8MHz (due to video amp limitations). Note also that the horizontal ramp rate selected for RST clocking control must also be communicated to the EBR so as to define the slope of the ramp generator.

j. Video output will continue (along with HORIZ INCR pulses in the INCREMENTAL mode) until the contents of the MAR of the line scan memory is equal to the contents of the LBAR. At this point the control sequences is notified; the video is blanked; RESET HORIZ pulse is transmitted to either clear the horizontal accumulator (INCREMENTAL MODE) or reset the ramp generator; VERT INCR is pulsed to position the beam one vertical unit up; and a 1 millisecc DELAY TIME is initiated.

k. When READY goes high (see para. g.) the control of the bus is released to the CPU. At this point the program is returned to the task of inputting, formatting and storing the next line of data. This task will normally take longer than the output of the line scan onto film, but should a faster input device be used, or a delay in film output occur, the input data may be prepared prior to the completion of the previous line scan. Positive feedback is therefore used, i.e., ATTN will be raised when the RST can accept a new data block. Thus provided EBR interlock is still high, ATTN will be set at the completion of the line scan.

l. The program will again interrogate the D STAT lines to insure that no changes have been made in switch settings (specifically RUN still activated) and then upon completion of storing the next line scan of data, will again initiate GO. The line scan memory system will, as in para. f., g., load the next line of data, and then process that data out to the H, V, and video lines. Note that the control sequences will not allow the conversion from inputting data to the RST to outputting to the EBR until DELAY TIME is reset.

m. This process continues until the program unit recognizes the last line of data from the data source (EOF). When this last scan line is ready to be transferred to the RST, the program resets the function bits to indicate LAST line and issues the last GO pulse for this frame. The LAST line command is received in the RST and held for completion of the output cycle to the EBR. At this point (MAR = LBAR) and LAST line; a RESET HORIZ and RESET VERT pulse is generated; FRAME ACTIVE is dropped indicating

a request for FRAM ADVANCE; and VIDEO is blanked. The DELAY TIME is also set but in this case it will have no effect since it is assumed that the EBR interlock will drop during film pull down and will be far in excess of 1 millisecond. When EBR interlock is reset, ATTN will again be raised, calling for program direction.

n. The control program, aware of its last line indication to the RST, will then make the determination to continue - i.e., record another frame or terminate. In this way preset software commands can be used to run any number of frames or any number of lines in a frame. It is assumed that an interactive operator station may be utilized for this purpose.

2.1.5 Applications

One of the advantages of an EBR in cartographic applications is that image formats can be easily varied by changing image size, film size, or film transport. The Cartographic EBR has at present, two film transport mechanisms:

- (1) 5½ inch film transport which punches two registration holes between frames prior to recording on a 5 x 8 inch format; and
- (2) a 35 mm fixed pin registered animation camera mechanism with a double image (24.6 x 37.3 mm) format.

Other optional transports for films of different widths, which punch registration holes between frames prior to recording can easily be installed in the Cartographic EBR.

Figure 14 and 15 illustrates how typically the master recordings made in the Cartographic EBR System can be used to produce map products either by making printing plates directly using a U.V. projection platemaker and a diazo plate or by producing a full size film negative which can be used in a conventional platemaker. The fine grain electron sensitive film allows enlargements of over 50 times without image degradation. Typical performance levels achieved with the Cartographic EBR are given in Table 1.

Some other applications that the Cartographic EBR System can be used for are illustrated in Figure 16, COM Master Microfiche could be generated at 24X and 48X reduction ratio without the use of the conventional step and repeat camera mechanisms used in CRT COM Recorders, thereby increasing the recording speed for alphanumeric. Characters recorded at 48X reduction are less than .002" high.

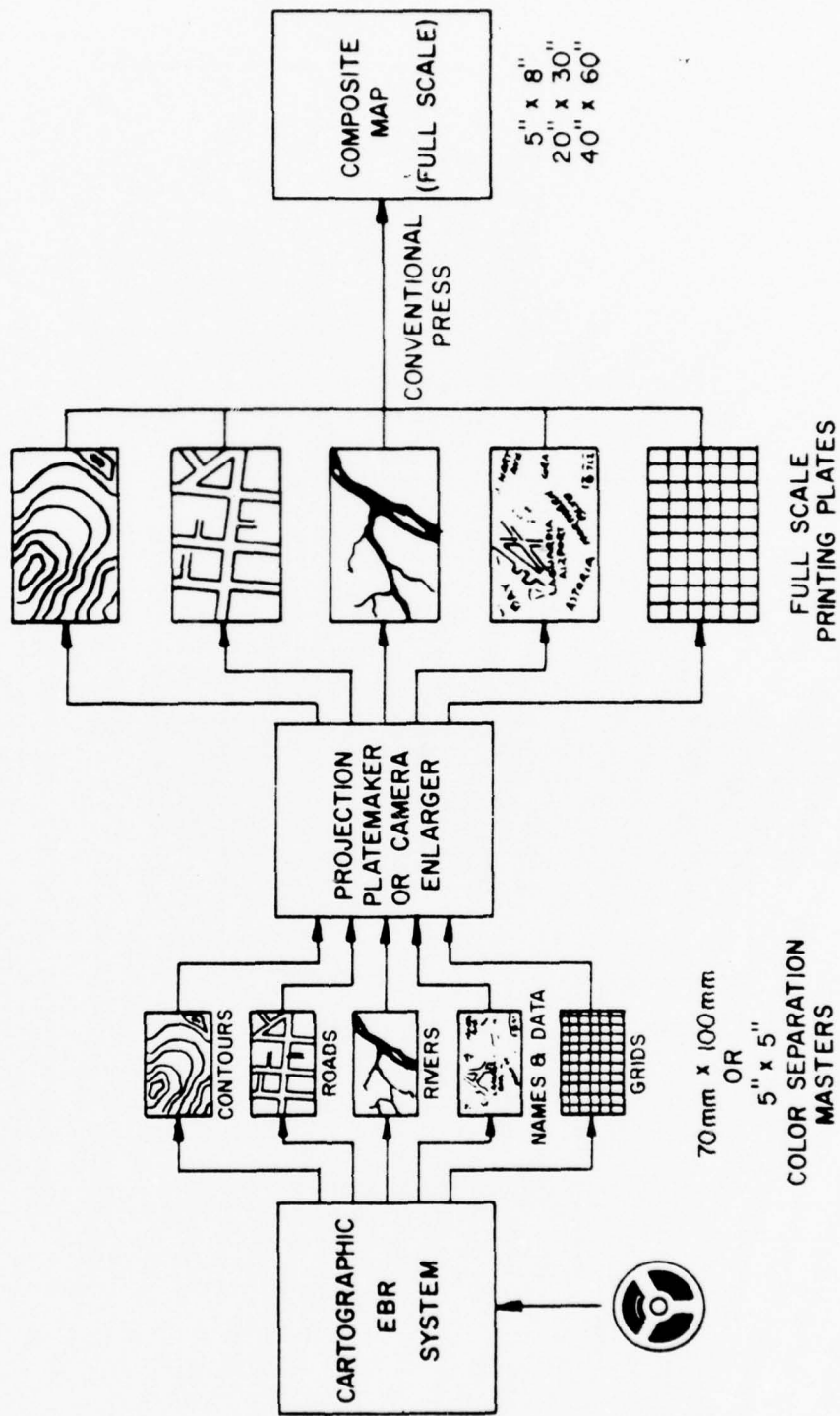

Figure 14. Application of Cartographic EBR for Map Production

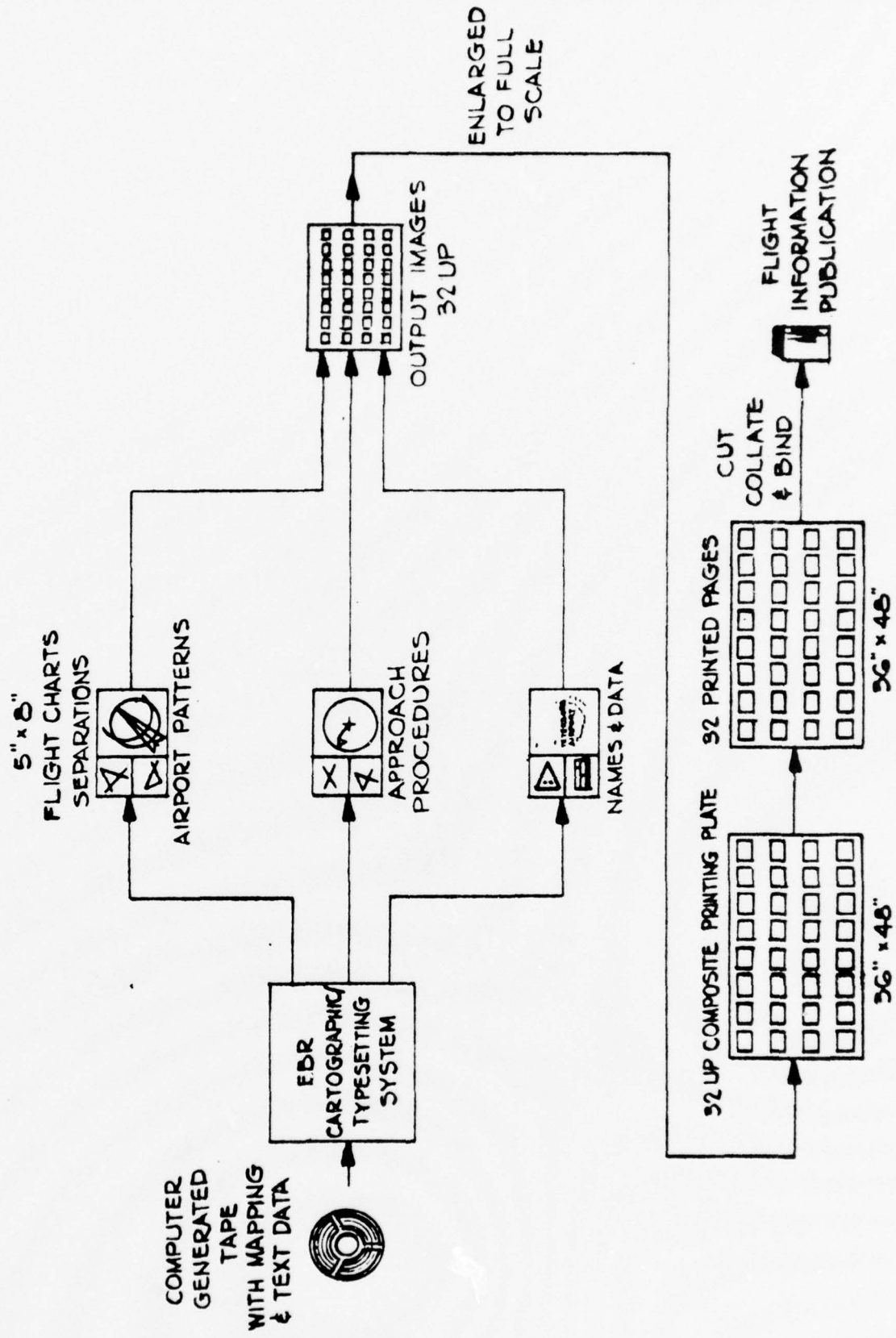

Figure 15. Application of Cartographic EBR for Aviation FLIP Chart Production

Table 1 - Cartographic EBR Performance

Film Transports	5½ inch and 35 mm
5½ Inch Image Format (Max)	5 x 8 inches
35 mm Image Format (Max)	24.6 x 37.3 mm
Beam Diameters	3 & 6 microns
Beam Addressability	32,768 x 32,768
Vector Plotting Speed	125,000 points/sec
Line Width Control (5 Bit)	3 - 250 microns
Character Sizes (at final product scale)	4 - 36 points
Character Generation Speeds 4 - 36 Points	1360 - 225 Character/Sec
Character Rotation	0 - 359° in 1° increments
Raster Scan Rates	Variable up to 2 KHz
Dynamic Range	64 shades of gray
Optical Density (D _{max})	2.3+
Video Bandwidth	10 MHz
Repeatability of Sequential Images	0.003%
Geometrical Fidelity	0.03%

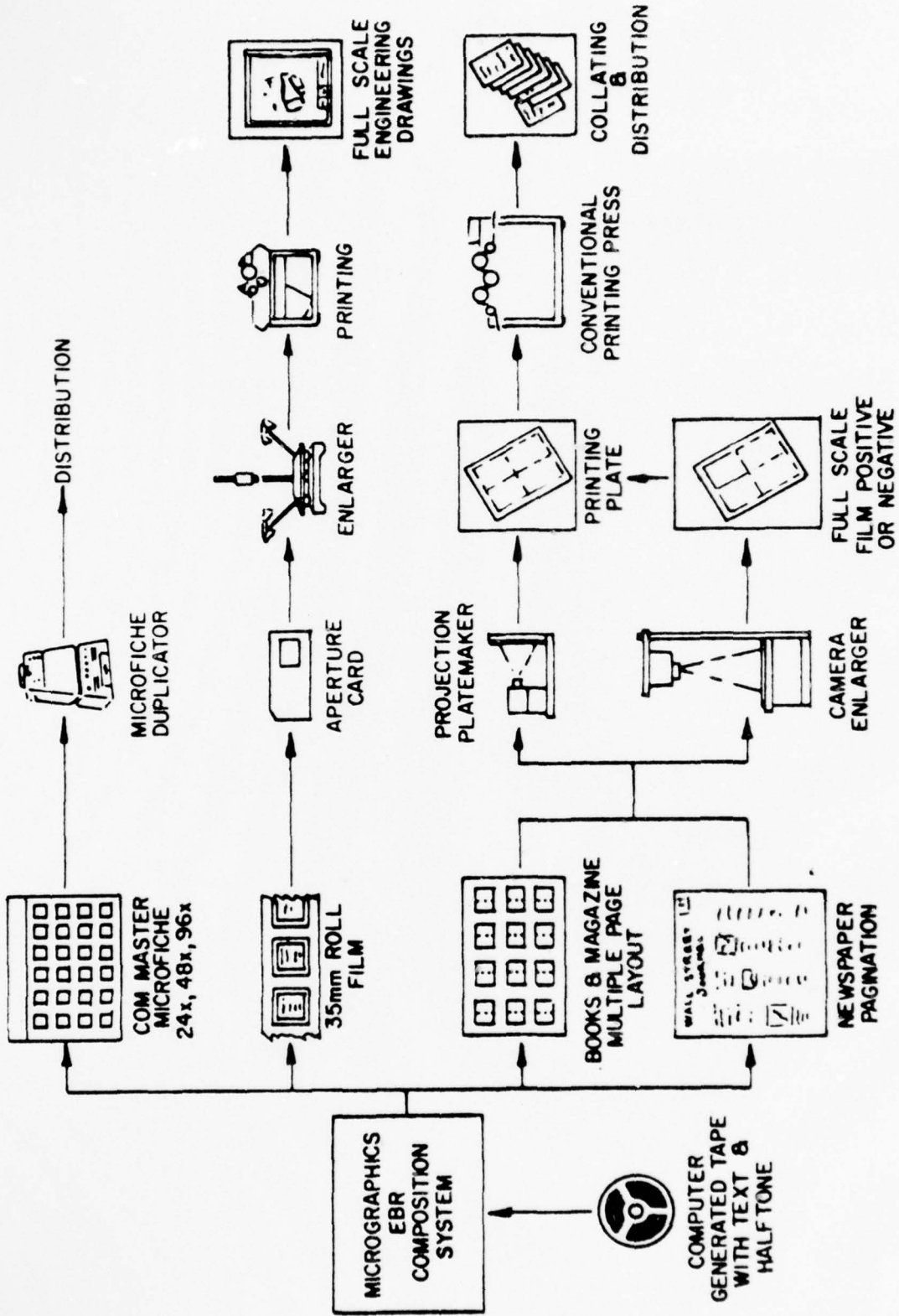

Figure 16. Other Applications for the Cartographic EBR System

Engineering drawings recorded on 35 mm aperture cards with a 3 micron line width at a plotting rate of 125,000 points per sec., on the very fine grain electron sensitive film, can easily tolerate the 30X blow back required for full scale reproduction of D & E size drawings. Since the edge acuity of EBR line work is very high the 1.1" x 1.4" aperture card images can clearly be enlarged to 34" x 44" full scale drawings.

Current performance levels of the Cartographic EBR System indicate that the system could be readily adapted for electronic composition and recording of text books, magazines or manuals, on film. Text and graphics could be co-mingled electronically on a master film sheet. The film sheet can be then enlarged to produce a lithographic press plate for use with conventional printing presses. Halftones or screens for area filled can also be recorded with an optionally available Electronic Screening Generator.

Graphic arts characters in magazines or books contain approximately 750 elements/inch. A typical 8" x 10" page would require a recording resolution of 6,000 x 7,500 elements. The Cartographic EBR is capable of recording over a large film format with a 6 micron diameter spot. Consequently, 16 pages of graphic arts quality could be recorded to produce a 4 x 4 matrix of microimages on a piece of 5" x 8" film and still retain full graphics arts quality. Accurate beam positioning across the entire format necessitates using the commercially available 18 Bit digital to analog converters (DAC's) providing a 256K x 256K addressing capability. The EBR characters are recorded with a small subraster which can be randomly positioned, scaled, or rotated.

2.2 Computer Controller

2.2.1 System Description

The Cartographic EBR Computer Controller is shown in Figure 17. It consists of mostly DEC hardware and software. The computer hardware is assembled in the four (4) cabinets shown in Figure 1 and includes the following equipment.

- 1 - 7 Track, 800 bpi Magnetic Tape Unit
- 1 - 9 Track, 800 bpi Magnetic Tape Unit
- 1 - PDP 11/05 CPU with 32K Core Memory
- 1 - RK05 Disk Drive
- 2 - Direct Memory Access Interfaces (DR11B)
- 1 - ASR 33 Teletype
- 1 - Adage Model 100A Terminal & Vector Generator

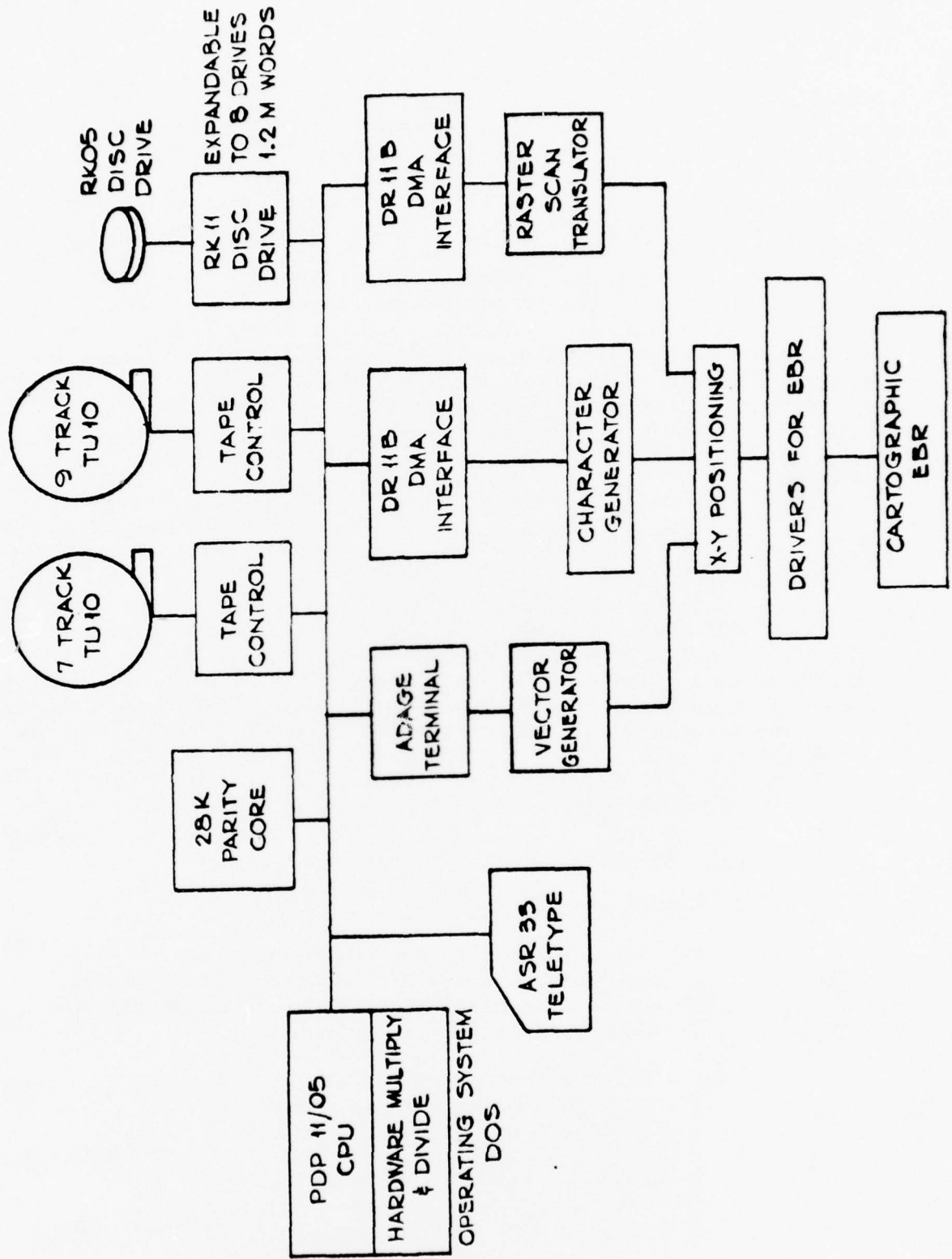

Figure 17. Computer Controller Configuration

CPU & Memory

The Central Processing Unit is a DEC PDP 11/05 with 32K of 16 Bit read/write core memory and contains the following features:

- Programmer Console
- Asynchronous Serial Interface for Console Terminal
- Line Frequency Clock (KW11-L)
- Automatic Power Fail Detection/Restart Capability
- 4-Level Automatic Priority Interrupt
- Extended Arithmetic (Hardware Multiply and Divide)
- Basic Mounting Chassis and Power Supply
- Rack Mountable Slides
- Basic Diagnostics on Paper Tape

The CPU and memory are mounted in a standard DEC cabinet. Only 28K of core is addressable under the present configuration.

Magnetic Tape Units

Two cabinet mounted magnetic tape units (7 and 9 track) are provided as inputs to the system. The magnetic tape drives use magnetic tape reels containing up to 2,400 feet of 1/2 inch wide industry standard magnetic tape with a data storage density of 800 bits per inch. The tape drives have a read/write speed capability of 45 inches/sec. The magnetic tape controller units in the TMA11 unit can be used to expand the input system up to 8 TU10 tape transports of either 7 or 9 track.

The seven track tape unit is used for loading digital representation of fonts on to the magnetic disk mass storage to serve as a font library for character and symbol generation; for introducing plotting commands for generating vectors; and for software development.

The nine track tape unit is used primarily in the raster scan mode which generates line work or continuous tone imagery from data stored directly on the tape; and for software development.

Disk Storage

The mass storage unit which provides storage for digitized fonts, the system operating software, and is used for software development, is a RK11 DEC pack Cartridge Disk Drive and Control. The system contains one 1.2 Million word RK05 removable disk drive, but could be expanded to 9.6 million words of data storage by adding up to eight disks to the control unit. Average access time for each drive is 70 milliseconds.

Teletype

An ASR 33 Teletype is provided to program the minicomputer with a variety of software routines; control the selection of tape from the magnetic tape readers; and to print out listings of software commands.

Direct Memory Access (DR11B) Interfaces

To provide efficient transfer of data to and from the memory of the PDP 11/05 CPU, two DEC general purpose direct memory access (DMA) interfaces were provided to move data between the unibus to the two of the principle user control electronics subsystems (i.e. Raster Scan Translator and the Character Generator) rather than using program control data transfers.

The interfaces consist of four registers: command and status, word count, bus address and data. Operation is initialized under program control by loading word count with 2's complement of the number of transfers, specifying the initial memory or bus address where the transfer is to begin, and by loading the command/status register with function bits.

Whichever subsystem has been commanded to operate, the interface will recognize these functions bits and will respond by setting up the control inputs. If the subsystem requests data from memory or a unibus device, the DR11-B performs a Unibus Data In Transfer (DATI) and loads its data register with the information held at the referenced bus address. The outputs of this register are available to the subsystem and the output data from the memory is buffered. If the subsystem requests data to be written in the memory, the DR11-B performs a Unibus Data Out Transfer (DATO), moving data from the sub-system to the referenced bus address. This input data from the subsystem is not buffered. Transfer of a specific number of words will proceed at a rate compatible with the subsystem operation. Because of the operating modes of the other principle functional subsystem, (the Vector Generator), only two DMA are required.

Adage 100B Storage Display

The Adage 100B Storage Display has four functions:

- a. Display of plotting beam,
- b. Vector Generation and Control
- c. Display of digital data and software routines
- d. Selection of data on magnetic tape to be recorded with EBR.

2.3 Electron Beam Recorder

2.3.1 General Description

The Cartographic Electron Beam Recorder (EBR) is an instrument which converts electrical signals representative of map features, alphanumeric characters, graphic plots or variable density pictures into latent images on electron sensitive film. The latent image is formed by exposing the film with a precisely controlled, finely focused electron beam. The EBR may be regarded as analogous to a cathode ray tube (CRT) recorder where the lens and the phosphor faceplate have been removed and the recording medium placed in the vacuum.

The Image Graphics, Inc., EBR-2000 series, shown in Figure 18, was adapted for cartographic applications which require high resolution, fast recording speed and wide dynamic range.

The Cartographic EBR is shown schematically in Figure 19. It consists of a high resolution electron gun, an electromagnetic system for focusing, deflecting and controlling the electron beam, film transport mechanisms for handling various film media, a fully automatic vacuum system which maintains suitable vacuum in various parts of the recorder and a number of highly regulated power supplies, electronic circuits, and monitors.

Various recording media may be used in the Cartographic EBR: (a) high resolution fine grain silver halide electron sensitive film which is processed by conventional wet chemistry after exposure to electrons; (b) dry silver which forms visible images by heat processing after exposure; (c) direct recording film which forms images directly on exposure to electrons and requires no processing whatsoever; (d) electrostatic films and papers which are processed with toner solutions; and (e) electron

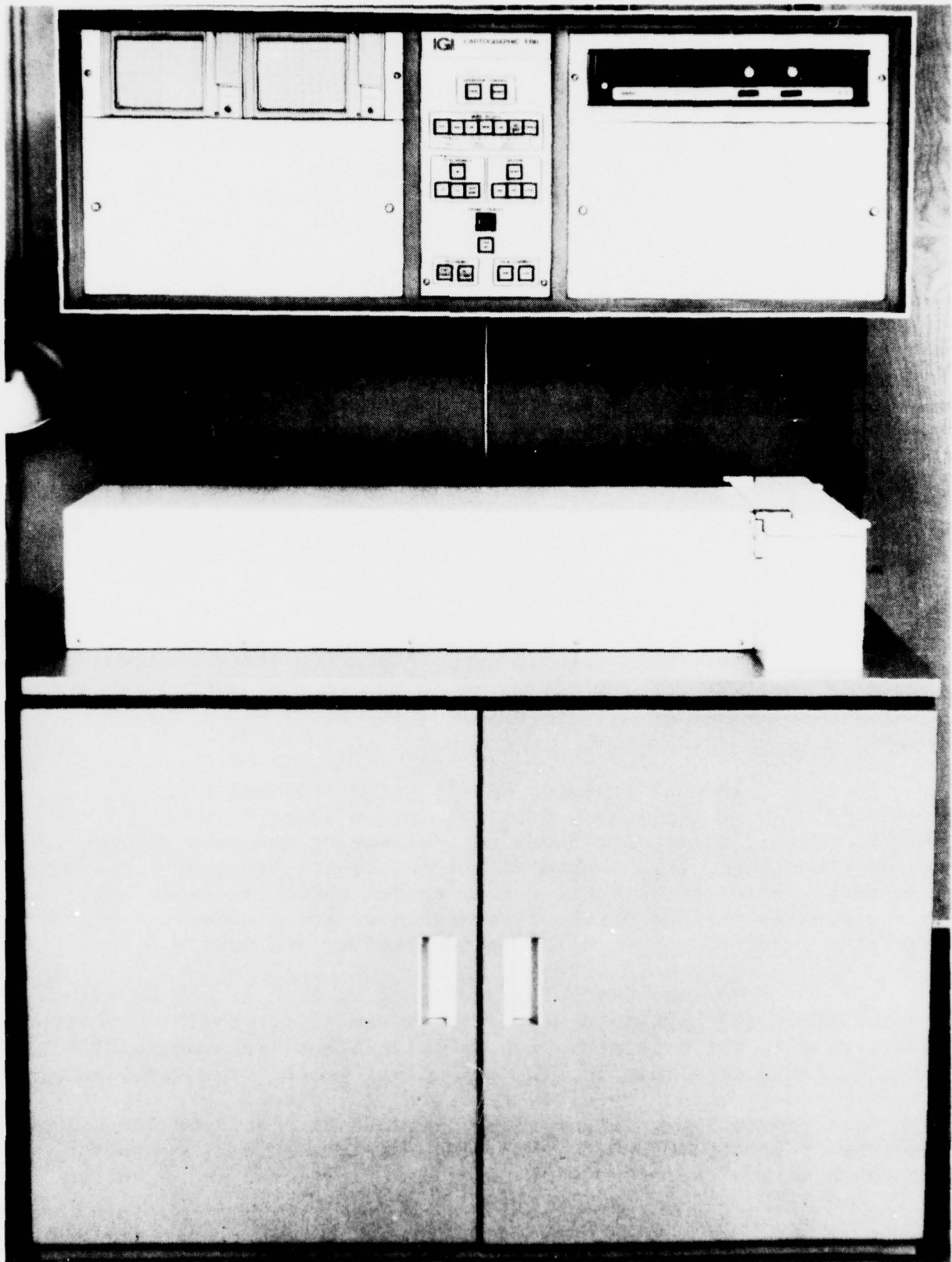

Figure 18. Image Graphics, Inc. - EBR 2000

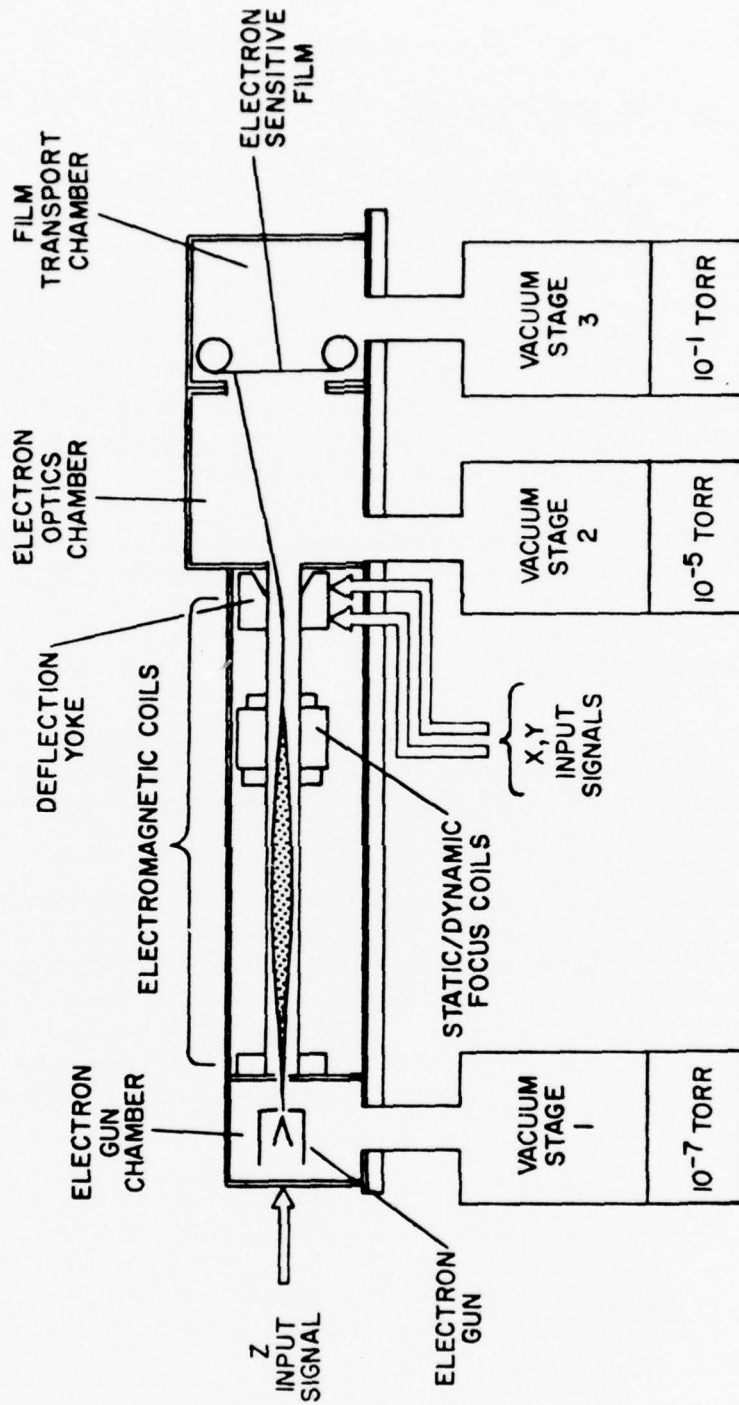

Figure 19. Schematic Layout of Cartographic EBR

resists which can be developed by conventional means.

2.3.2 Technical Description

The Cartographic EBR is a multi-format electron beam recorder that is used for the production of various Mini-maps and analog or digital raster images. Operation control functions have been kept to a minimum and are readily accessible to provide the operator with convenient control and ease of operation. Since this Cartographic EBR is to be used in experimental applications at U.S.A.E.T.L., it has been designed to provide flexible operation, enabling the operator to vary many of the recording parameters as required. Modular construction provides ease of maintenance, troubleshooting and repair.

Section 2.3.2 describes the functions and operations of the various EBR system components shown in Figures 20, 21 22 and 23.

2.3.2.1 Vacuum System

The vacuum system of the Cartographic EBR, is a high performance, fully automatic, three stage, differentially pumped system which ensures that proper vacuum is maintained in every section of the EBR.

Since the EBR vacuum system is fully automatic, no prior vacuum technical background or experience is required to operate the EBR. The operation of the entire vacuum system, once power has been turned on, is controlled by two pushbuttons on the EBR Operation Control Panel. As operational vacuum is attained in each of the three principal sections of the EBR, vacuum status is displayed on the EBR Operation Control Panel by indicator lamps.

The warm-up time for the vacuum system of the Cartographic EBR, from a cold start to operational vacuum, is less than one hour. The pump-down time with a full supply of film is less than 5 minutes. Typically, the Electron Gun Chamber is operated at 10^{-7} Torr, the Electron Optics Chamber at 10^{-4} Torr and the Film Chamber at 10 to 100 millitorr.

Diffusion Pumps

The vacuum system of the Cartographic EBR uses two 3-inch, 300 litres/second diffusion pumps, provided with

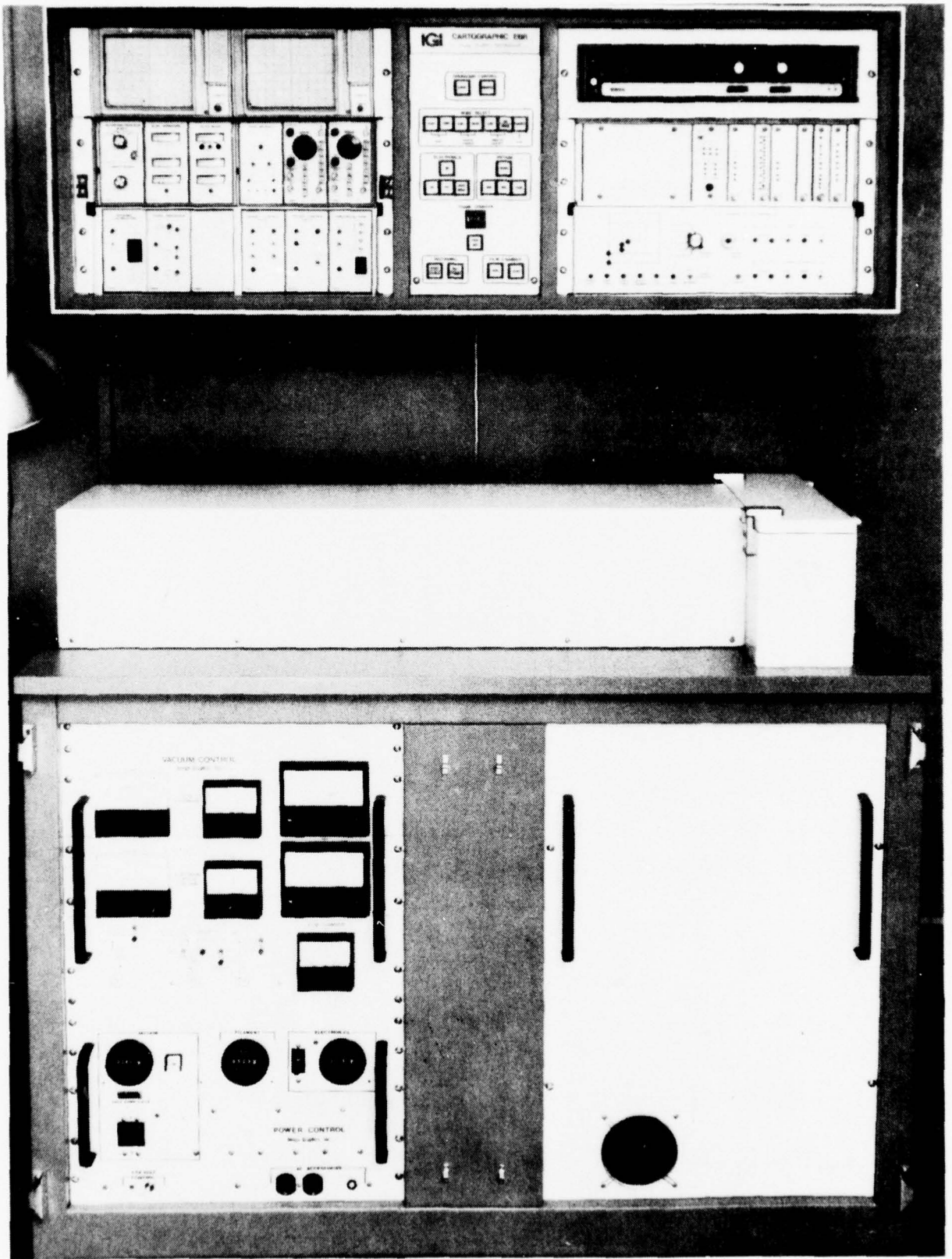

Figure 20. Cartographic EBR - Front View - Doors Removed
41

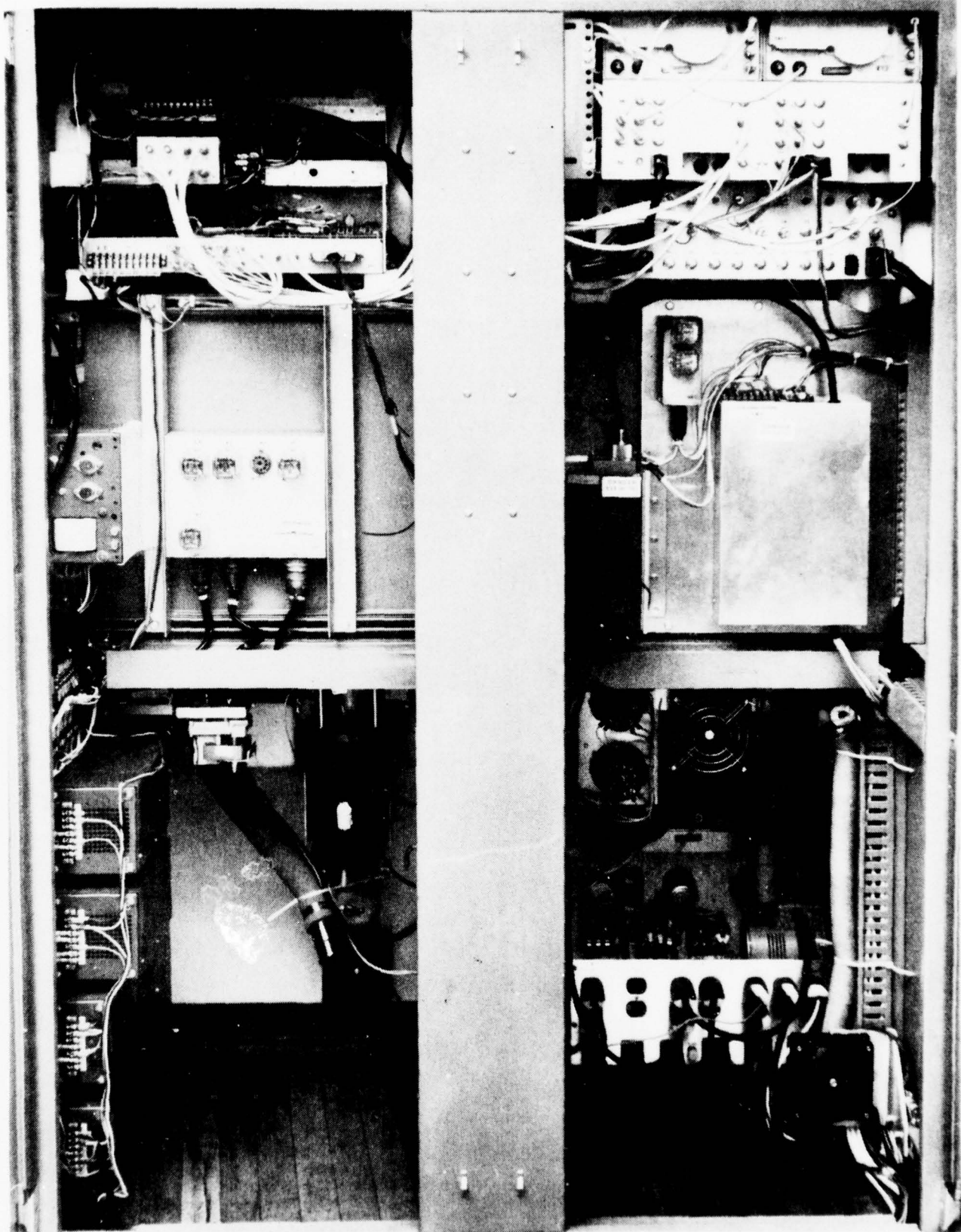

Figure 21.
Cartographic EBR - Rear View - Doors & Mechanical Pumps Removed

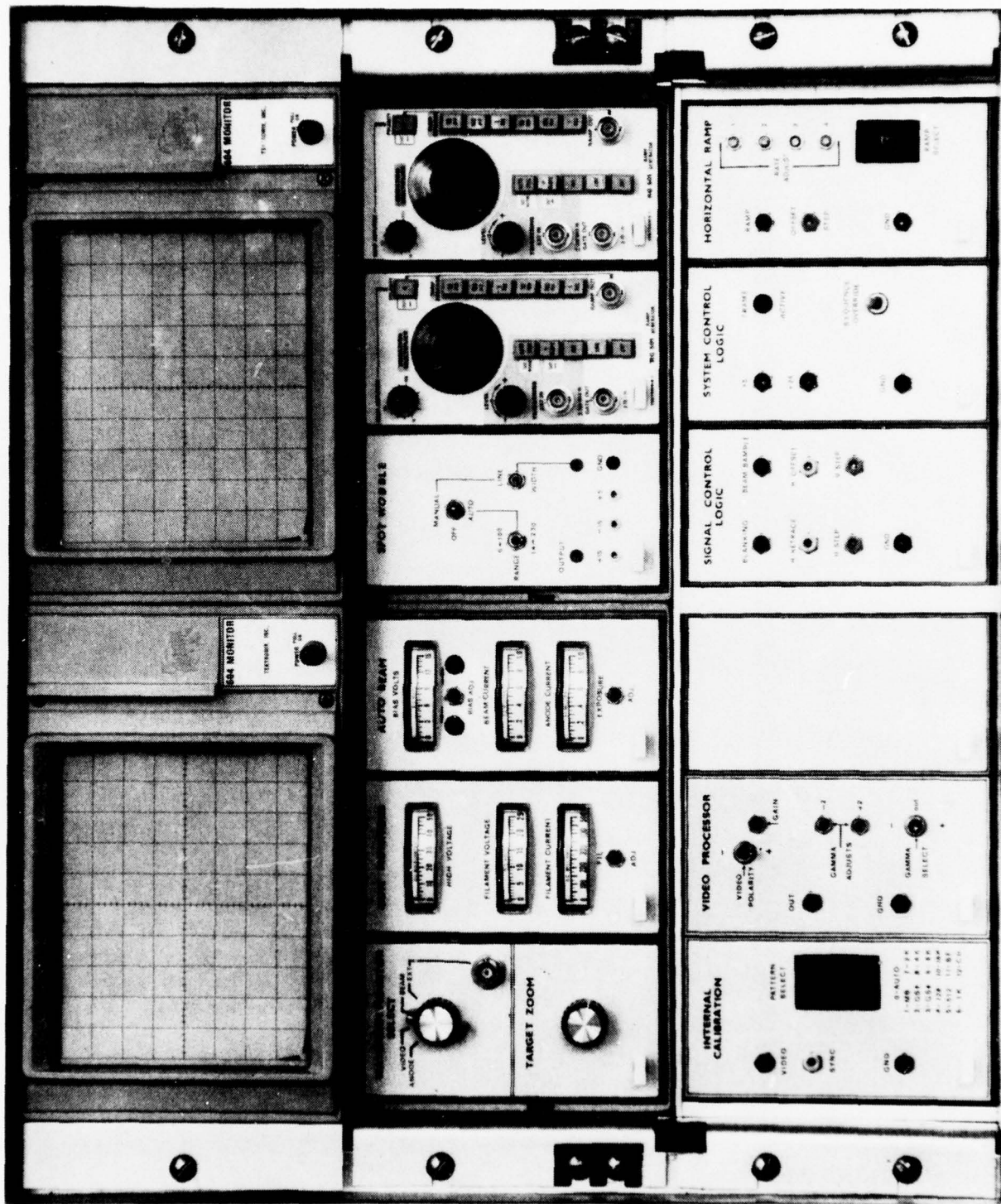

Figure 22. Cartographic EBR - Upper Bay - Left

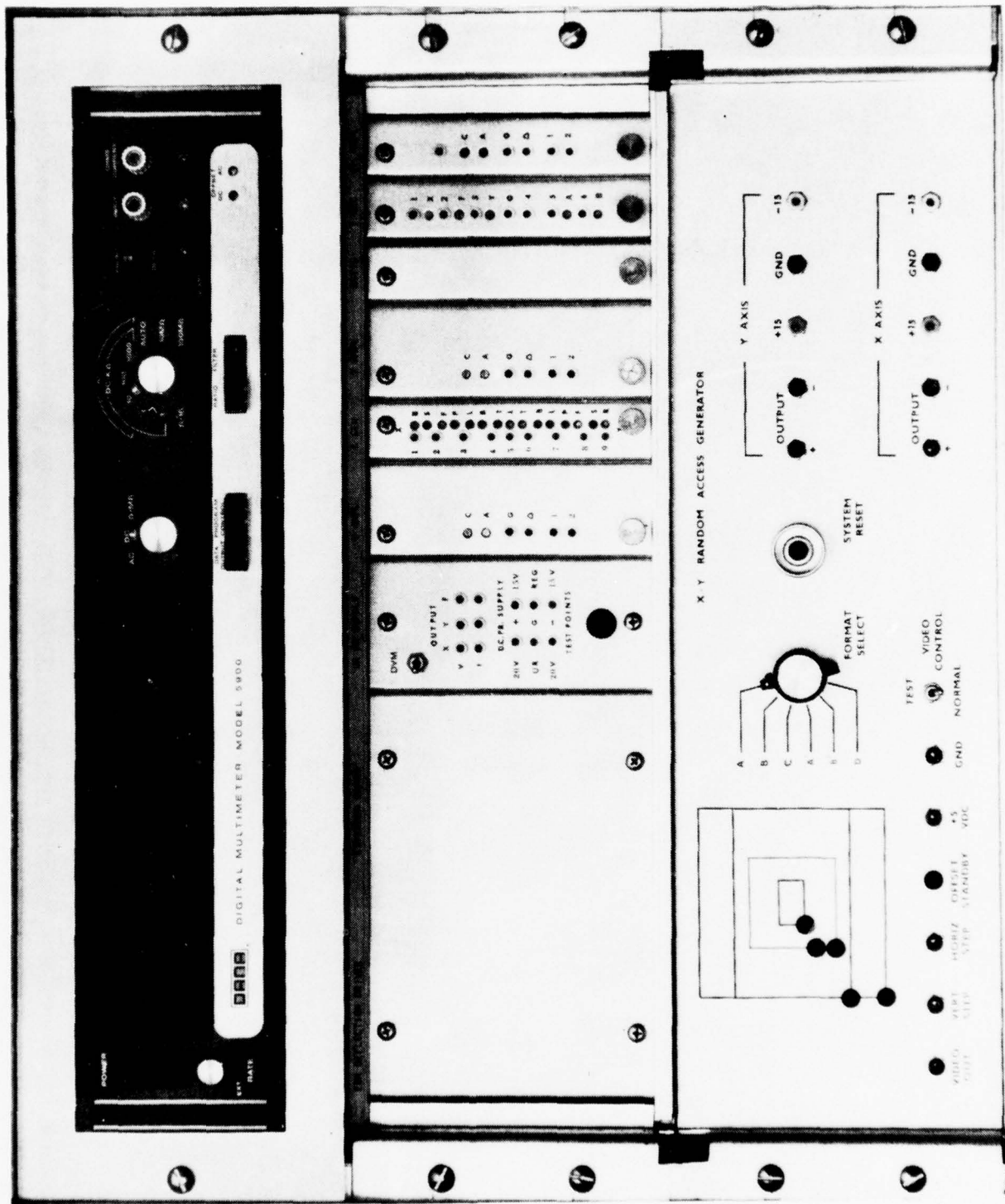

Figure 23. Cartographic EBR - Upper Bay - Right

special fans to minimize the 60 Hz magnetic fields generated by the fan motors. These diffusion pumps have very low oil back-streaming rates, and in addition, have been provided with optically dense, high conductance baffles to minimize oil contamination problems.

Mechanical Pumps

Three direct drive mechanical pumps are used in the vacuum pumping system of the Cartographic EBR. Two of these pumps, having a displacement of 4.5 CFM, are used as backing pumps for the diffusion pumps, whereas the third pump, with a displacement of 14.1 CFM, is connected directly to the Film Chamber.

The following features of the mechanical vacuum pumps are significant for electron beam recorders:

- High Efficiency
- Direct Drive
- Two-Stage Construction
- Oil-Sealed
- Anti-Suckback Design
- Built-in Safety Valve
- High Water Vapor Tolerance
- Vented Exhaust
- Compact
- Low Weight
- Vibration Free
- Quiet Operation
- Modular Construction, for easy servicing in the field.

Vacuum Gauges

The vacuum system of the Cartographic EBR includes seven high performance vacuum gauges. The two cold cathode discharge gauges are provided with set-point controls in the 10^{-3} to 10^{-7} Torr range, and have been modified to operate with special vacuum sensors. These vacuum sensors have low external magnetic fields and consequently do not affect the electro-optical alignment of the EBR.

The other five vacuum gauges used in Cartographic EBR are of the thermocouple type, operating in the 2 Torr to 10^{-3} Torr range. Two of these indicate the foreline pressure of the diffusion pumps, whereas the other three are provided with set-point controls and are used in the automatic control of various vacuum valves in the EBR.

Fail-Safe Features

The automatic sequencing of the operation of all the vacuum valves is very simple and fail-safe. It is controlled by the output of the vacuum gauges which measure the actual vacuum in every section of the EBR and is not controlled by time delays.

The single vent valve is normally closed and has to be energized to open. Consequently, in the event of a power failure, the EBR vacuum system will not be vented and the hot diffusion pump fluid will not be oxidized by exposure to the atmosphere.

Since the mechanical pumps are provided with built-in safety valves, the vacuum system of the EBR will remain totally sealed and undamaged, should an accidental power failure occur.

2.3.2.2 Electron Gun

The electron gun used in the Cartographic EBR, is a triode of unique and proprietary design with a directly heated thermionic emitter. It incorporates many of the latest improvements which have been introduced in the design of electron guns for transmission electron microscopes, micro-probe analyzers, scanning electron microscopes, as well as for electron beam recorders.

The aperture in the grid cup (Wehnelt cylinder) of the electron gun is small resulting in a less divergent beam and consequently in improved resolution. The grid cup is provided with precise adjustments for accurately centering the cathode.

The cathode of the electron gun is a directly heated thermionic emitter of the type used in applications where the ultimate stability is demanded and long operating life is important. It features a gradated loop configuration and a unique tip geometry to optimize heat transfer characteristics.

The cathodes, mounted on ultra stable ceramic bases, are made of a tungsten-rhenium alloy to ensure ultimate performance and have a MTBF of thousands of hours, provided that they are operated in an adequately high vacuum.

The electron gun used in the Cartographic EBR is designed to also accept pointed filaments which feature a crystal oriented tip with a 1000 Angstrom radius. The use of such pointed filaments makes it possible to focus the electron beam to an even smaller size recording spot and consequently results in improved image resolution. However, the calculated MTBF for pointed filaments is considerably shorter than that of graduated loop filaments.

The anode structure of the Cartographic EBR electron gun is designed to accept commercially available, platinum apertures used in electron microscopes.

2.3.2.3 Electron Optics Coils

The arrangement of electron optics coils used in the Cartographic EBR is shown in Figure 24.

The electron optic coils consist of an alignment yoke for positioning the beam through the center of a high resolution static and dynamic focus coil which focuses the beam of electrons into a concentrated round spot approximately 6 microns in diameter; an astigmatism corrector for removing residual spot distortion caused by any magnetic asymmetry in the focus coil; a high performance deflection yoke which is capable of positioning the electron spot across the format without introducing any appreciable spot distortion or spot growth; and a spot wobbler yoke to provide automatic line width control during plotting. The entire electron optic column is surrounded by a magnetic shield to prevent interference and interaction of stray magnetic fields with the electron beam.

Geometrical image errors such as pincushioning are corrected electronically. The deflection yoke has sufficiently low inductance for high speed subraster generation of graphic arts characters so that a separate subraster yoke and deflection system are not required.

Beam Alignment Yoke

The beam alignment yoke is used to position the electron beam precisely along the electro-optical axis of the EBR. It features a unique coil design which results in uniform characteristics in both alignment axes and a low residual magnetism core.

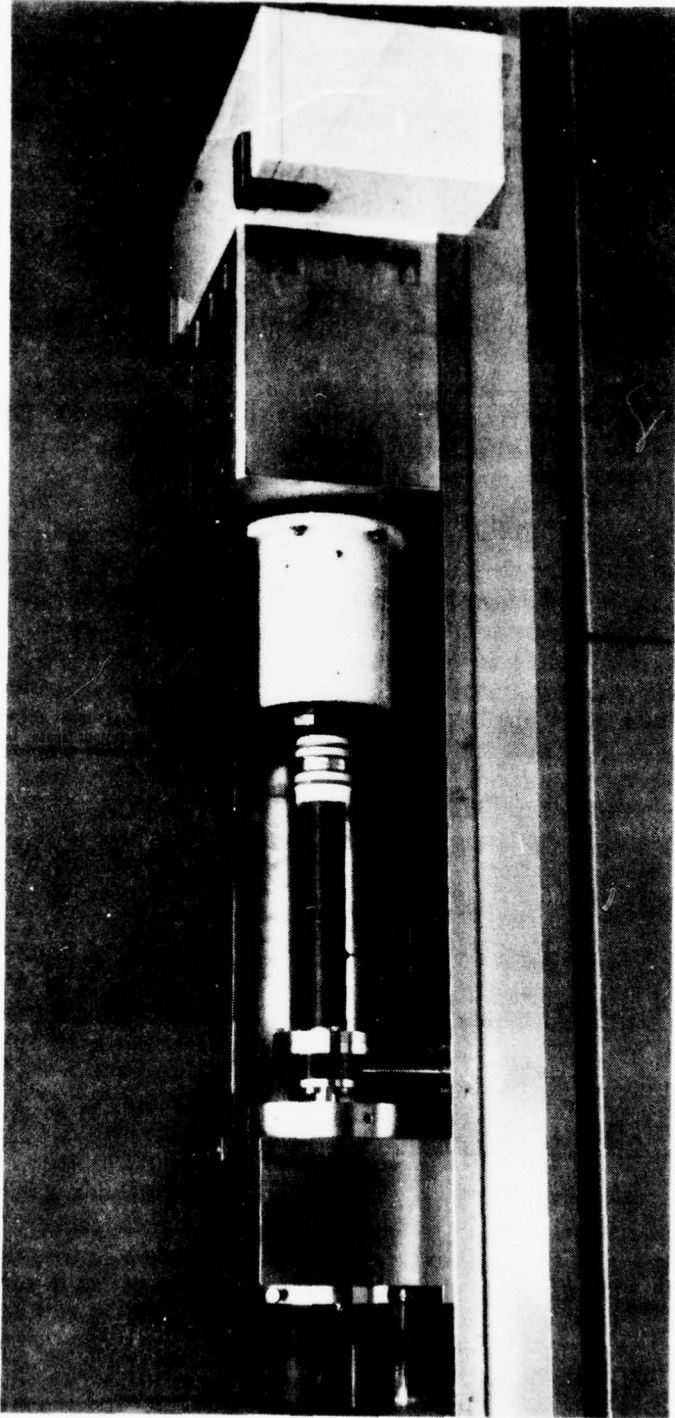

Figure 24. Electron Optics Column

The beam alignment yoke is mounted immediately in front of the anode aperture, thus minimizing the geometric image distortions which might occur if the electron gun is not perfectly aligned.

Static and Dynamic Focus Coil

A single gap static and dynamic focus coil assembly is used in the Cartographic EBR. The electron beam is focused at the center of the recording format by a very stable constant current through the main or "static" winding of the focus coil. Appropriate currents are applied to the "dynamic" winding of the focus coil to dynamically refocus the recording spot as it is deflected toward the edges or corners of the format.

The focus coil is mounted in the EBR sufficiently far away from the deflection yoke to eliminate spot distortions caused by the interaction of the magnetic fields of these components.

Astigmatism Corrector

An astigmatism corrector is used to compensate for the residual astigmatism of the focus coil. Basically, such a corrector consists of two sets of coils wound on a common annular core.

In order not to produce a component of deflection, the Cartographic EBR astigmator corrector is attached directly to the main electro-optic components housing so as to be precisely centered on the electro-optical axis.

Deflection Yoke

The deflection yoke produces the magnetic fields which precisely position the electron beam over the entire recording format. The deflection yoke for the Cartographic EBR uses a low loss ground ferrite core proportioned to provide an anastigmatic field and to eliminate higher order beam distortions. A unique coil winding configuration provides complete symmetry between deflection axes. Typical focus variations caused by the end turns of saddle or stator yokes have been eliminated. Consequently, using dynamic focus modulation, uniform focus over the complete recording format can be achieved. The deflection yoke winding method provides precise placement of coil turns so as to minimize geometric distortions.

Spot Wobble Yoke

A low inductance, air core, Spot Wobbler Yoke is mounted concentrically on the precision ground glass tube between the Beam Alignment Yoke and the Astigmatic Corrector, but much closer to the latter.

A 5 MHz signal of variable amplitude is applied to the Spot Wobbler Yoke in order to control the effective size of the recording electron beam, thus making it possible to record lines of variable widths.

Magnetic Shielding

The entire electron beam path, from electron gun to recording film, is thoroughly shielded from the interference of magnetic fields emanating from other nearby components, by a two-layer magnetic shield made of high magnetic permeability material. This reduces unwanted beam displacements due to EMI (particularly at 60Hz) to less than a micrometer.

2.3.2.4 Film Transports

Since the Cartographic EBR System will be used at U.S.A.E.T.L. to study the automated production of maps and other micrographic products, the EBR was specifically designed to accept a variety of film transport mechanisms. All film transports, as well as film gates, cut film holders, glass plate holders, test fixtures, or alignment phosphors, available for the Cartographic EBR, are easily interchangeable and are precisely mounted on two dowel pins located in the Film Chamber of the Cartographic EBR.

Initially only two film transports have been provided for the Cartographic EBR: a 5½ inch film transport, which automatically punches two registration holes in every frame of film and a fixed-pin, 35 mm film transport which uses film with standard motion-picture perforations. However, additional film transports or film gates are likely to be provided for the Cartographic EBR in the future.

5½ inch Film Transport

The 5½ inch film transport, shown in Figures 25 and 26, has a recording aperture of 8 1/16 x 5 1/32 inches which is adequate for recording standard "Flip Charts" at full scale.

All materials used in the fabrication of the film transport are vacuum compatible and totally non-magnetic. The film gate is hard chrome plated and highly polished to ensure that the normal operation of the film transport will not cause any film scratching.

The 5½ inch film transport is provided with an automated registration hole punching mechanism to ensure the accurate superimposition of recorded images. The distance between the two registration holes along the center line of a film frame is exactly 9 inches and the diameter of the registration holes is 0.250 inch.

The 5½ inch film transport has also been provided with a "fiche" format insert. The aperture of this insert (5 9/16 x 4 1/16 inch) is sufficiently large to accommodate all the standard "fiche" formats.

Operation of the frame advance mechanism is controlled either manually from the control panel or automatically, as the recording of an EBR image is completed.

35 mm Film Transport

The 35 mm film transport, shown in Figures 27 and 28, makes use of an Acme Vistavision Camera Movement, manufactured by Photo Sonics Inc. The Eastman Type registration pins in the Vistavision movement were specially modified for use in the Cartographic EBR. The manufacturer claims an accuracy of ± 0.0001 inch in the location of these registration pins.

A 2 cycle pulldown mechanism advances 1.493 inches (i.e., 8 perforations) of film through the 35 mm film gate which has an aperture of 1.496 X 0.991 inches. Consequently care must be taken in positioning the images recorded on 35 mm film in order to prevent image overlap.

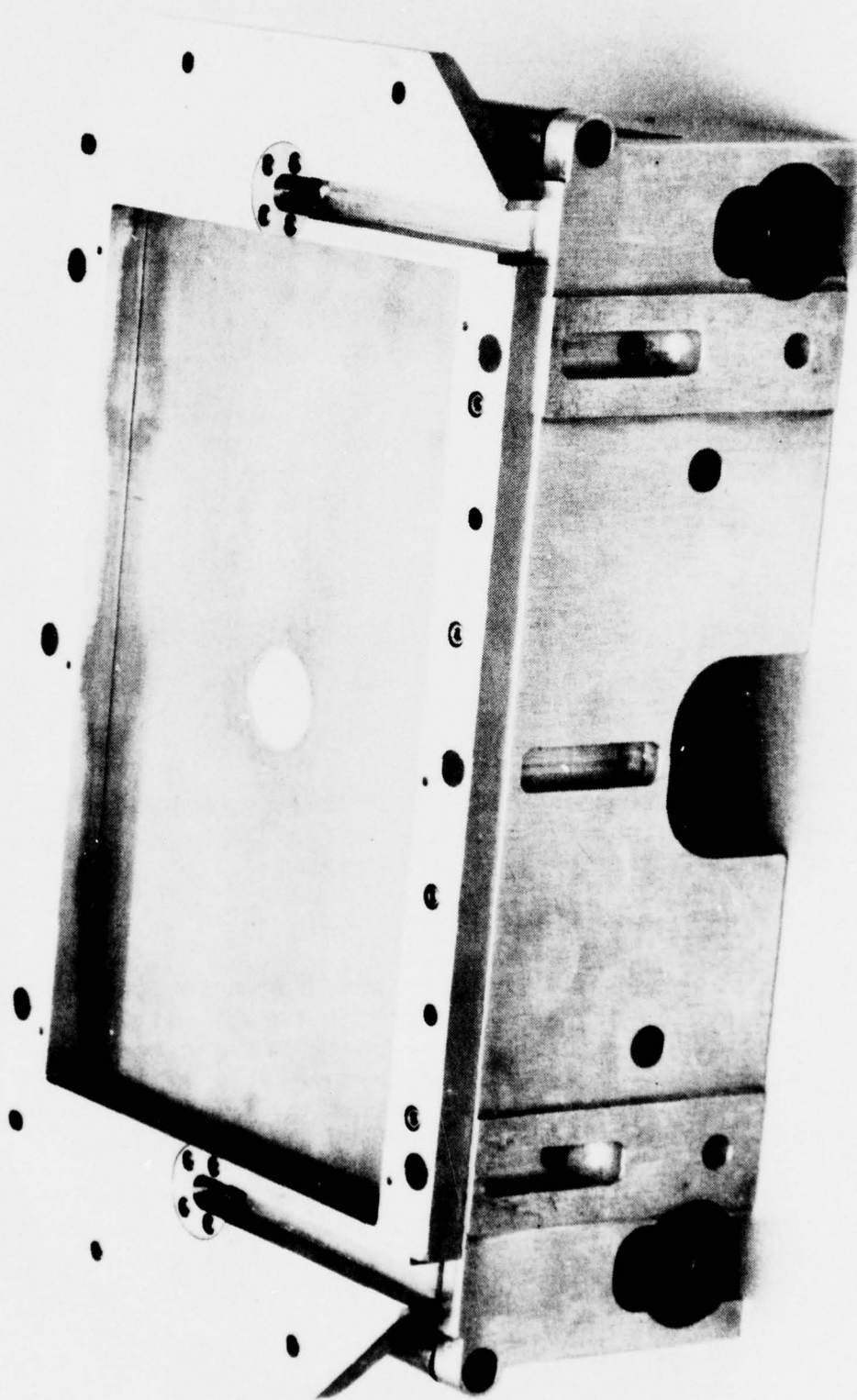

Figure 25. 5 1/2 Inch Film Transport - Front View

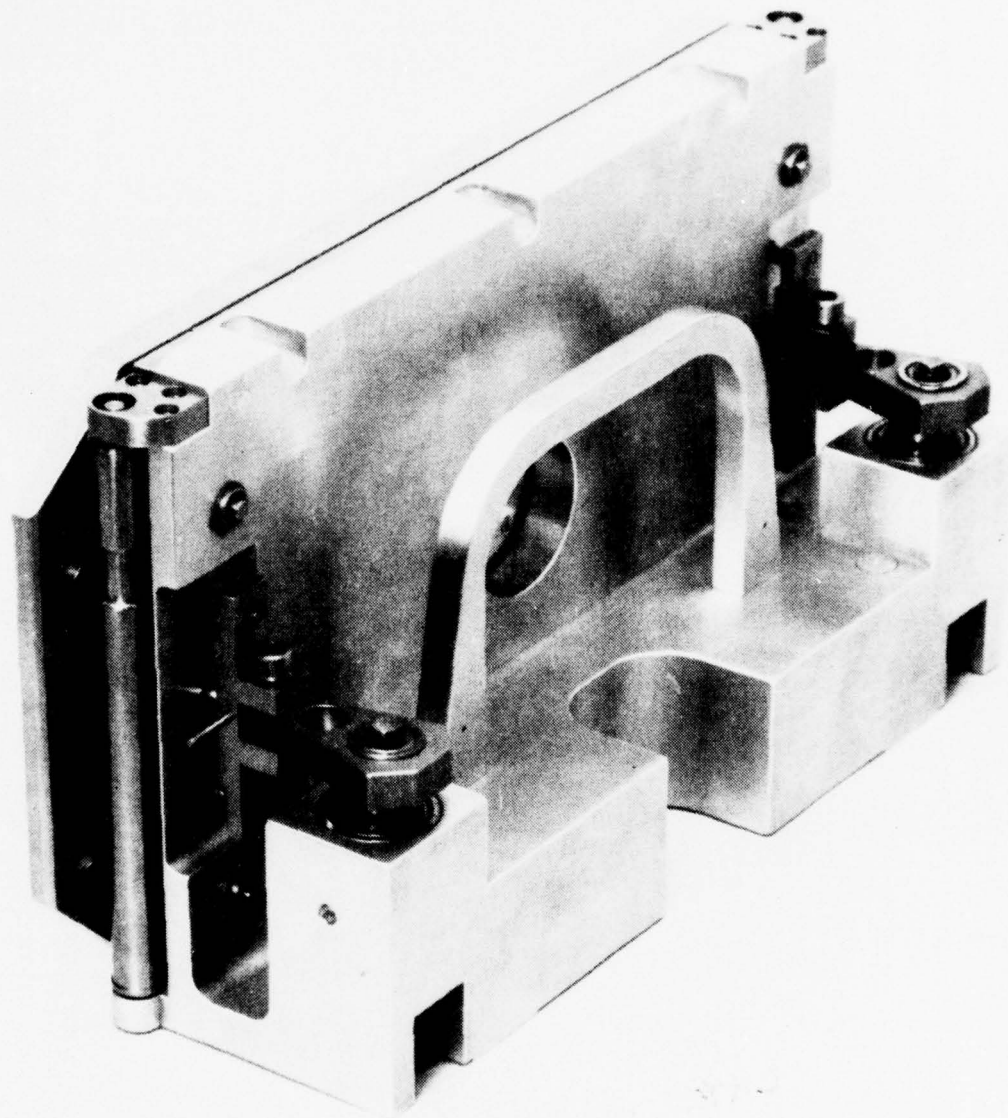

Figure 26. 5½ Inch Film Transport - Rear View

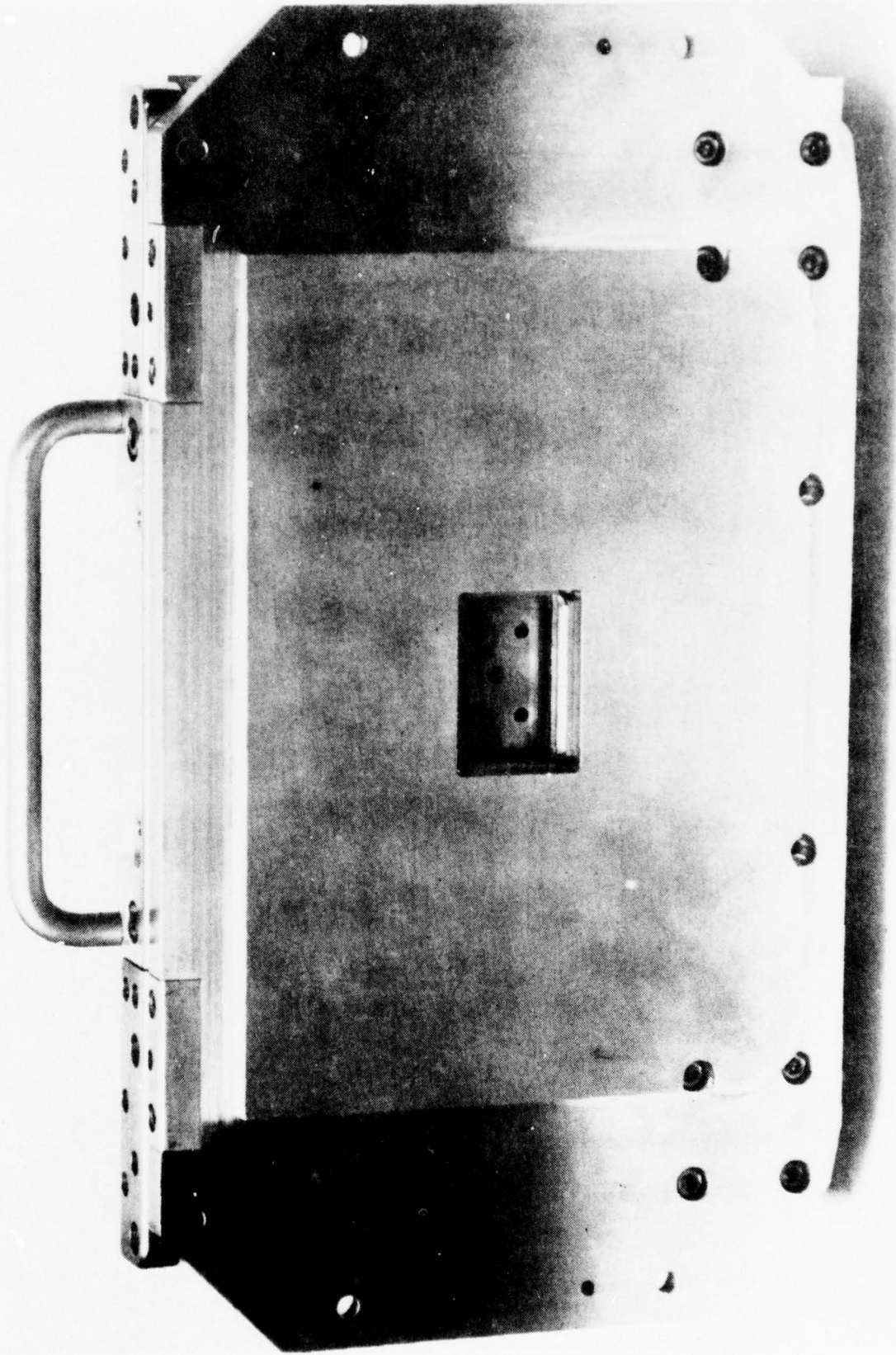

Figure 27. 35 mm Film Transport - Front View

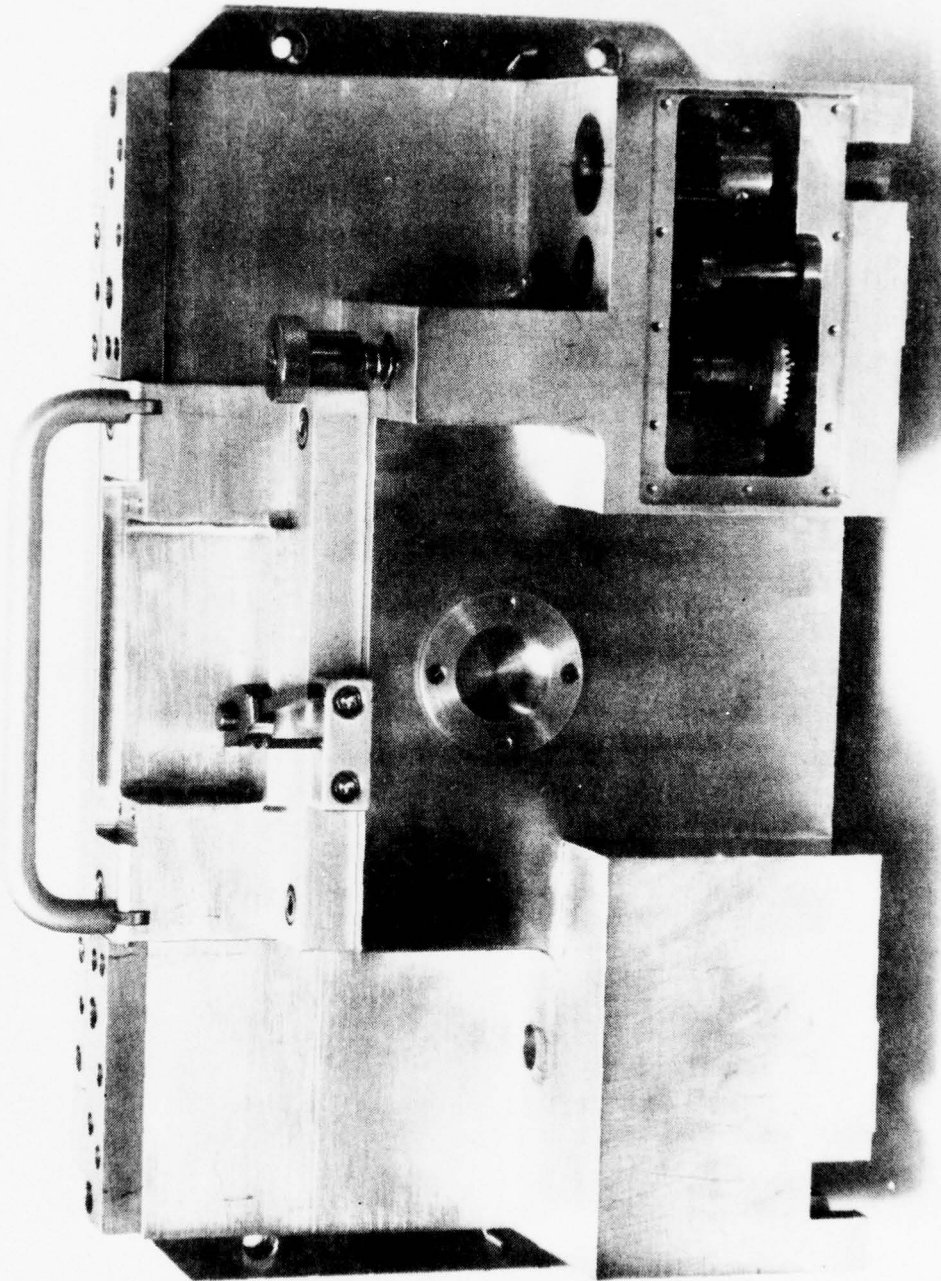

Figure 28. 35 mm Film Transport - Rear View

should be noted that for the 35 mm film transport it is the punch drive mechanism that advances the film and the film drive mechanism that takes-up the advanced film.

Special adapters have to be installed on the film supply and take-up shafts in the Film Chamber when the 35mm film transport is used.

2.4 Cartographic EBR System Performance

Numerous recordings made on 5½ inch and 35 mm film over a period of several months indicate that the performance levels shown in Table I can be achieved or exceeded. The performance limitations of the Cartographic EBR System are discussed in the following sections. It should be noted that many of these limitations are imposed by the physical and photographic properties of the recording film as well as film processing and film handling techniques.

2.4.1 Recording Spot Size and Resolution

The effective diameter of the focused electron spot in the Cartographic EBR is either 6 or 3 microns, depending on the type of electron gun used (see Section 2.3.2.2). Losses in resolution due to scattering of electrons within the emulsion layer are not significant if proper recording films, such as Kodak SO-219, are used. However, when coarser grain, lower resolution films are exposed in the Cartographic EBR the loss of resolution becomes clearly evident.

Full advantage cannot be taken of using the ultra high resolution electron gun (3 micron spot diameter) until the electrical "noise" present on the Cartographic EBR deflection system is further reduced.

A major source of deflection noise is the Symbol/Character Generator (GFE), which also introduces positional offsets and positional instability into the deflection system of the Cartographic EBR. The performance of this unit should be improved, or better yet, a higher performance Symbol/Character Generator should be installed in the Cartographic EBR.

Work on the Random Access X-Y Positioning Unit (GFE) performed on this contract substantially reduced the "noise" and settling time of that unit. Most of the improvements were obtained when higher performance 18 bit DAC were substituted for the original 16 bit DACs.

A minor contributor to the deflection noise of the Cartographic EBR is the Geometric Corrections Generator. An improved version of that generator is being developed at IGI and should be available in the near future.

2.4.2 Beam Addressability

The positioning of the electron beam in the Cartographic EBR is controlled by 18 bit DACs so that a maximum addressability of 262,144 x 262,144 points per frame is theoretically available, however, at present the addressability is limited to 32,768 x 32,768 points.

The Cartographic EBR has been provided with size selector switches which control the size of the address matrix elements. The matrix elements are always square (i.e. of equal size in the X and the Y axes) and, as currently configured, these matrix elements have been pre-set to:

- 1) 6.2 micron (8 inches \pm 32,768)
- 2) 4.3 micron (140 mm \pm 32,768)
- 3) 2.6 micron (86.5 mm \pm 32,768)

Thus the addressability per image recorded in the Cartographic EBR depends on the size of the image and the selected size of the address matrix element. For example, an 8 x 5 inch image with 6.2 μ m elements has an addressability of 32,768 x 20,480 positions. It should be noted that, should the need arise, the size of the address matrix elements could easily be preset to values other than those indicated above.

The Cartographic EBR has also been provided with an Origin Selector switch so that the image origin (X=0, Y=0) can be correctly positioned in the upper left hand corner of a given film format.

2.4.3 Dynamic Range/Density

The Cartographic EBR System was specified to be capable of recording images with a D_{\max} greater than 2.3 and a D_{\min} less than 0.1. As shown in Figure 29, a maximum density in excess of 3.0 and a "fog-plus-base" density of 0.08 can easily be achieved using Kodak SO-219 film.

The signal-to-noise ratio of the video amplifiers in the Cartographic EBR is greater than 100:1, thus with a proper 8 bit input video signal, it should be possible to record gray scales with more than 64 distinguishable shades of gray. This was confirmed experimentally using test tapes supplied by ETL.

PROCESS: D-19, 4 m., 66°F

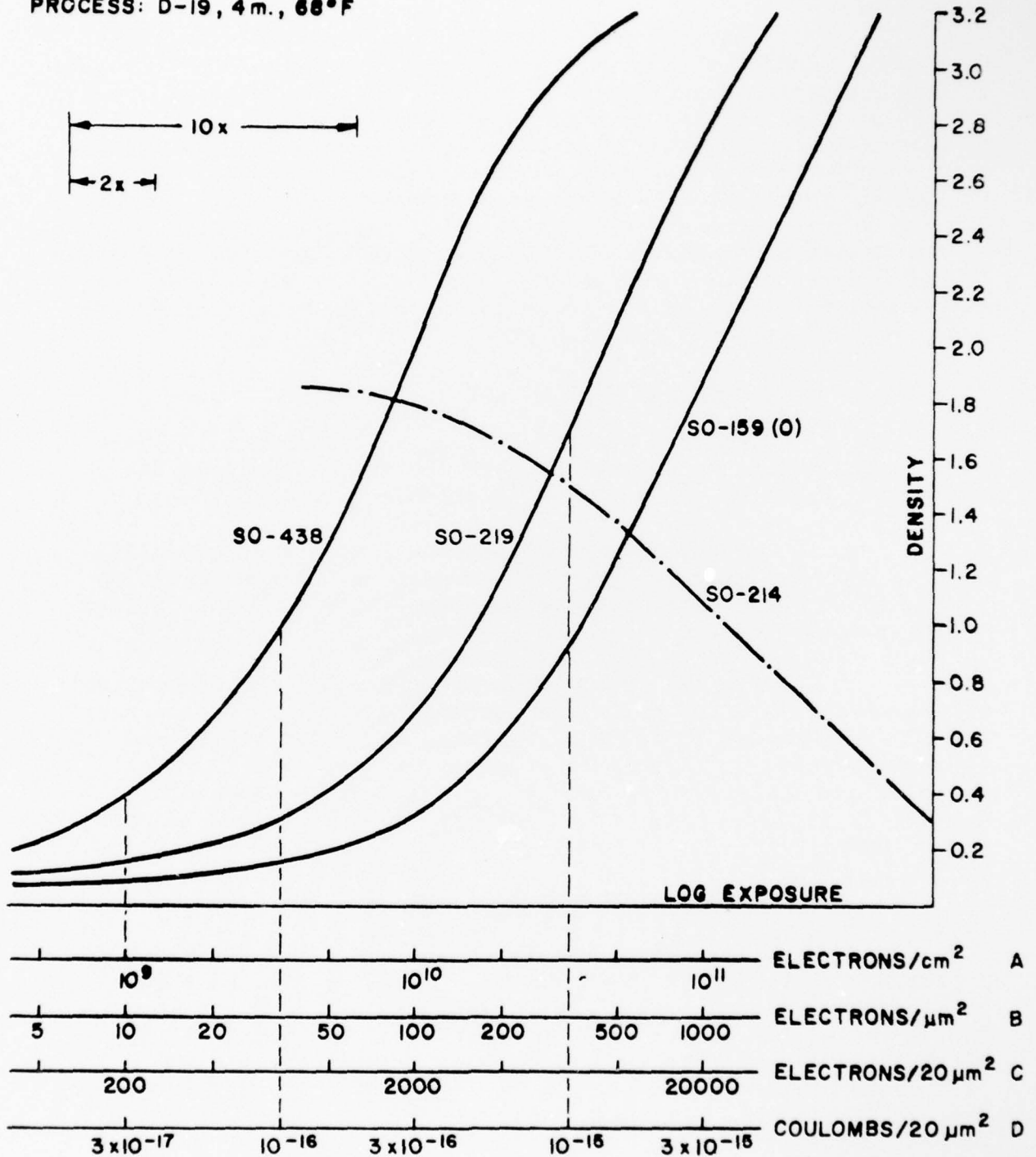

Figure 29. Sensitometric Characteristics of Electron Sensitive Films

Density variations in images recorded in the Cartographic EBR are primarily due to non-uniform or non-repeatable film processing and non-uniformities in the sensitivity of the recording film. It has been demonstrated (for example, on the LANDSAT EBR at GSFC) that with proper film processing and using a very uniform recording film, it is possible to reduce density variations in electron beam recorded images to about .02 optical density units. However, since at present there is no control on the Cartographic EBR film processing at ETL, density variations of 0.2 or greater can be expected. It should be emphasized that such density variations are normally insignificant for recording line work, characters, symbols, etc.

2.4.4 Video Bandwidth

Electron beam recorders have successfully been used to record at bandwidths of up to 300 MHz and possess the inherent capability of recording at gigahertz rates. (24)

The Cartographic EBR has a specified bandwidth of 0 to 10 MHz, which is more than adequate since the recording bandwidth of the entire Cartographic EBR System is input limited by the magnetic tape.

In the Vector Mode of Operation, the Cartographic EBR records at 125,000 points per second, or 8 microseconds per point. Even though the time of exposure per point is limited to 1 microsecond, to allow 7 microseconds of settling time for the DACs and the deflection amplifiers, the video bandwidth equivalent to these comparatively short exposure pulses is well under 10MHz.

2.4.5 Positional Repeatability

The positional repeatability of images recorded in the Cartographic EBR is affected by many factors, of these the most significant are: a) the stability of the EBR deflection system and b) the dimensional and positional stability of the recording film. Electrical measurements made using a high performance DVM on the entire deflection system of the Cartographic EBR, (excluding the Character Generator [GFE]), show a short term stability (hours) of better than .003% and a long term stability (days) of better than .01%. It should be noted that

residual magnetism effects of the deflection yoke, which may affect the position of the recording beam, cannot be detected by such electrical measurements. These measurements simply indicate the degree of positional repeatability that can be expected if the same input tape is used.

Spurious beam displacements in the Cartographic EBR due to instability of the deflection system are very much smaller than apparent image displacements due to film displacements or dimensional changes of the film (see Section 2.5).

2.4.6 Geometric Fidelity

The geometric fidelity of images recorded in the Cartographic EBR is controlled by the Geometric Corrections Generator which provides stable corrections for all first, second and third order distortions.

The Geometric Corrections Generator has 12 precise adjustments for the following:

- Skew
- X Bow
- Y Bow
- Y Diff. linearity
- X Diff. linearity
- X trapezoid
- Y trapezoid
- X pincushion
- Y pincushion
- X radial linearity
- Y radial linearity
- X edge rotation
- Y edge rotation

It has been found experimentally that these adjustments can be made with sufficient precision so that each of the above mentioned distortions can be reduced to less than 0.02% of the image diagonal or approximately ± 0.002 inches over the entire 8 x 5 inch format.

Another effect which can show up as a geometric distortion in images recorded in the Cartographic EBR is caused by the residual magnetism of the deflection yoke. The maximum magnitude of this effect is about 0.002 inches for the 5 x 8 inch format and correspondingly less for smaller image formats. If

required, geometric image distortions (i.e. beam positional displacements) due to residual magnetism in the deflection yoke could possibly be further reduced by using an electronic compensation technique currently being developed at IGI. Alternatively, a deflection yoke with lower residual magnetism could be developed, but this would entail a sizeable developmental program.

Other geometric image distortions in the Cartographic EBR (discussed in Section 2.5) are caused by positional and dimensional instability of the recording film.

2.5 Recording Film

The recording film selected for the Cartographic EBR System is Kodak Direct Electron Recording Film, Type SO-219 which possess the following features:

- Very high resolution, in excess of 500 LP/mm
- Extremely fine graininess, which allows subsequent enlargements of recorded images at magnifications of 50X or more
- High maximum density and gamma which make it particularly suitable for cartographic recording
- An electrically conducting layer under the emulsion, to prevent charging effects
- A very low sensitivity to light, which allows the film to be handled in bright yellow safe lights
- A polyester base which is vacuum compatible and provides excellent dimensional stability

2.5.1 Sensitometric Characteristics

The sensitometric characteristic curve of SO-219 film exposed to 15 KV electrons and processed in D.19 chemistry is shown in Figure 29. It can be seen that the maximum density of this film is greater than 3.2 and that, for the particular processing conditions, the maximum slope of the characteristic curve (i.e. gamma) is 2.2. Thus, with proper exposure and processing, SO-219 can most easily achieve the specified D_{\max} of 2.3.

The presence of an electrically conducting layer under the emulsion tends to make the sensitometric uniformity of SO-219 somewhat lower than that of comparable conventional films (without a conducting layer). However, the sensitometric uniformity of SO-219 is adequate for cartographic recordings.

2.5.2 Dimensional Stability

The SO-219 film used in the Cartographic EBR has a polyester* support, or base, which possess better uniaxialism and better dimensional stability than any other type of commercially available film base. However, while polyester base films represent a marked advance in dimensional stability they still do exhibit some dimensional changes. In fact, no such thing as absolute dimensional stability exists; even sensitized glass plates show very small dimensional changes under some conditions.

The dimensional changes that occur in photographic films are due to a variety of causes such as temperature, humidity, processing, aging, mechanical stress etc. and each variable must be considered separately. The inherent film properties which are important for each type of dimensional change, together with the magnitude of each change for various films are discussed extensively in numerous technical publications. In particular, see references (27) and (28) in Section 5.0.

Table 2 reproduced from a Kodak publication summarizes some typical dimensional changes of Kodak films. For comparison it should be noted that sensitized photographic glass plates have a Thermal Coefficient of Linear Expansion of $< .0005\%$ per $^{\circ}\text{C}$ and a Humidity Coefficient of Linear Expansion of $< .0001\%$ per 1% RH.

2.5.3 Positional Stability

In the late phases of this program it became clearly evident that the positional and dimensional instabilities of the recording film are the primary limitations to the positional accuracy and repeatability of images recorded in the Cartographic EBR. A detailed study of factors which affect the positional and dimensional stability of the recording film is beyond the scope of this program, but some relevant conclusions, arrived at on the basis of practical experience, can be summarized as follows:

*Kodak trade name ESTAR and DuPont trade name CRONAR.

TABLE 2

TYPICAL DIMENSIONAL CHANGE CHARACTERISTICS OF KODAK FILMS

Base Type	Cellulose Triacetate		ESTAR Ultra-Thin Base		ESTAR Thin Base		ESTAR Base		ESTAR Thick Base
Base Thickness, μm	133		38		64		102		178
Base Thickness, Mils	5 $\frac{1}{4}$		1 $\frac{1}{2}$		2 $\frac{1}{2}$		4		7
Typical Emulsion Type	B & W		B & W	Color	B & W	Color	B & W	Color	B & W
Gel/Base Ratio	0.09		0.32	0.80	0.20	0.46	0.08	0.21	0.05
Direction of Test	Length	Width	*	*	*	*	*	*	*
Humidity Coefficient of Linear Expansion, Unprocessed† % per 1% RH ¹	.0055	.0065	.0050	.0110	.0033	.0050	.0018	.0030	.0015
Thermal Coefficient of Linear Expansion, † %/°C‡	.005	.006	.002	.002	.002	.002	.002	.002	.002
Processing Dimensional Change Range ²									
% Shrinkage§	-.10		-.08		-.06		-.03		-.01
% Swell	+.04		+.04		+.03		+.03		+.02
Processing and Aging Shrinkage (In sheets) ⁴ §									
1 wk @ 50 C-20% RH	.15	.20	.09	.12	.08	.10	.03	.06	.02
1 yr @ 25 C-60% RH	.30	.35	.07	.07	.04	.04	.03	.03	.02

*The dimensional properties of Estar base films may vary slightly in different directions in the sheet; these differences are not necessarily between the length and width directions but may be between diagonal directions.

†At 21 C between 15 and 50% RH. ‡At 20% RH between 21 C and 50 C. §Tray processed specimens.

The dimensional characteristics were determined in accordance with the appropriate sections of the American National Standards Institute "Methods for Determining the Dimensional Change Characteristics of Photographic Films and Papers," PH1.32-1959. The specific references are:

(1) PH1.32 Section 6 (2) PH1.32 Section 7 (3) PH1.32 Section 8 (4) PH1.32 Section 9

1. For the most critical applications of the Cartographic EBR, the recording medium (silver halide, electron resist or other) should have a rigid and dimensionally stable support such as glass, quartz, silicon wafers, metal, etc. As pointed out in Section 2.3.2.4 the Cartographic EBR was specifically designed to accept holders for various recording media coated on rigid supports.

2. If the recording medium to be used in the Cartographic EBR is coated on a transparent and flexible support, a polyester film base is definitely superior to other commercially available film bases such as cellulose acetate butyrate or cellulose triacetate.

3. There is little difference in the dimensional stability of Kodak films on ESTAR base and DuPont films on CRONAR base, as chemically these bases are identical. However, since the silver halide in DuPont films is not dispersed in gelatin, this may offer some minor dimensional stability advantages.

4. Temperature should be kept constant during recording, film processing, film storage, measurement of images recorded on the film and all subsequent operations involving the film (such as enlargement). A temperature control of 1°C would not be regarded as unduly stringent for critical applications.

5. High temperature processing of the recording film should be avoided. The processing cycles should be uniform and the overall wet time as short as possible.

6. High temperature drying of the recording film, after processing, should be avoided.

7. Any operation involving the recording film (be it recording, measuring, enlarging, contact copying, etc.) should be performed at a constant relative humidity. A RH control of 1 or 2% during such operations would not be regarded as unduly stringent for critical applications.

8. The recording film should always be given adequate time (in storage, recording, measurement or reproduction) to reach a temperature and humidity equilibrium.

9. The silver halide emulsion of the recording film should be as thin as possible since a higher base-to-emulsion thickness ratio gives better dimensional stability.

10. The recording film should be provided with an anti-curl backing.

11. The recording film should not be curled excessively at any time, be it in recording or storage, to avoid "core-set" and other distortions.

12. The differential pressure across the recording film in the Cartographic EBR should be kept low to minimize distortions due to film bowing.

13. The stiffness of the recording film should be as high as possible. Note that for a given type of film base, stiffness is proportional to the cube of the thickness.

14. The film should be clamped in the film gate of the Cartographic EBR as close as possible to the actual image recording area. That is why the special "fiche" size aperture insert was provided for the 5½" film transport and should be used when recording images smaller than 4 x 5½ inches. Preferably, different film transports and films of different widths should be used for recording images of different sizes.

15. One of the two registration hole punches in the Cartographic EBR should be elongated to facilitate subsequent registration of images. This registration process is greatly affected by dimensional changes of the recording film.

16. For critical applications, fiducial marks should be recorded along side the images in the Cartographic EBR. Such fiducial marks can then be used for the precise registration of images; this technique will tend to compensate for some of the positional and dimensional changes of the recording film.

17. A special proprietary film transport mechanism for large format EBR's has recently been developed by IGI. (The patentability of the principles of operation of such a film transport is being investigated). It is believed that if such a transport were to be installed in the Cartographic EBR some of the positional and dimensional instabilities of the recording film would be reduced.

Section 3.0 Conclusions

The Cartographic EBR System developed by Image Graphics, Inc., for U.S.A.E.T.L. under Contract No. DAAG53-75-C-0221 is a very versatile experimental system for the generation of map products. The Cartographic EBR offers a unique capability to perform high quality recordings both in vector and raster formats.

Map products currently printed by the Defense Mapping Agency (DMA) Centers which could be produced with an Automated Cartographic EBR System are numerous. Some of these have been listed below:

TOPOGRAPHIC CENTER

(a) Full Size Maps & Charts Enlarged from EBR Minimap Separations:

- .Black Maps-containing terrain information
- .Topographic Maps
- .SACARTS (Semiautomatic Cartographic System) Products
- .Joint Operations - Ground Maps 1:250,000 scale
- .Air Crash Search and Rescue Maps
- .Military City Maps
- .Small Scale Maps
- .Seasonal Maps

(b) 35 mm Microfilm Strips

- .Reformatted Radar Data
- .Archival Library of Map Separations (24x and 48x)
- .Engineering Drawings

(c) Full Size Maps & Charts Recorded with EBR

- .Proof Plots for lineal and raster data
- .Digital Data Base Plots
- .Earth Resources Technology Satellite (ERTS) Imagery
- .Ortho Photo Maps (PICTO MAPS)
- .Graphics Data

AEROSPACE CENTER

- (a) Full Size Maps & Charts enlarged from EBR Minimaps Separations:
- Tactical Pilot Charts
 - Air Target Charts - Series 200
 - Enroute Charts
 - Digital Data Base Plots
- (b) Full Size Maps & Charts Recorded with EBR
- Instrument Approach Procedures (Flip Charts)
- (c) 35 mm Microfilm Strips Separations Recorded with EBR for:
- Projected Maps on CRT Display for Navy ATE & TAC Planes
 - Rear Port Projection, Horizontal simulation display strips for F-111 plane

HYDROGRAPHIC CENTER

- (a) Full Size Maps & Charts Enlarged From EBR Minimap Separations:
- Coastal Charts - Depth Soundings
 - Pilot Charts - Wind & Weather Conditions
 - Route Charts
 - OMEGA EDITION
 - Publication Notice to Mariners
 - Simulation Plots
- (b) 35 mm Microfilm & Microfiche
- Digital Data Base Plots
 - Archival Storage (Currently 50 users)

Section 4.0 Recommendations

1. Cartographic EBR Systems should be specifically configured for operation in the three DMA Centers, i.e., Aerospace, Hydrographic and Topographic Centers, on a gradual scheduled basis; the Centers adapting to the use of the EBR as practical operational capability is established.

The EBR Systems should be capable of vector plotting, raster scanning, raster plotting, and character generation of cartographic quality. Standard cartographic film formats should be defined, i.e., 5" x 8", 4" x 6" (Fiche) and 35 mm, etc.

2. The Cartographic EBR Systems should be driven with a high capacity computer control system using a PDP 11/34, 11/45 or equivalent and a multi task software operating system such as RSX 11M, Version 3. This computer hardware and software gives complete compatibility with the CRT Print Head Systems to be delivered to the three DMA Centers under Contract No. DAAG53-76-C-0182 and offers maximum performance flexibility and system growth potential.

3. The Cartographic EBR Systems should include IGI Symbol/Vector Generators to assure maximum speed and performance compatible with the EBR hardware.

4. Continued effort is required in improving applications software (i.e., plot programs) to develop a supported data base for an automated map production system based upon the EBR technology.

5. Suitable enlarging techniques from minimap masters must be established for map production. IGI has already successfully enlarged minimaps up to 10 feet x 4 feet, 5 feet x 4 feet, and 2 feet x 3 feet using an optical enlarger. ETL has enlarged 70 mm minimaps to 25" x 18" diazo plates directly with a LATADY U.V. Platemaker and film negatives using an Lanston Monotype Camera. ETL has also enlarged a FLIP chart recorded in 70 mm format to 6½" x 10½" using an experimental Laser Projection Plate Maker (Appendix A). AC has printed FLIP Charts recorded at full scale on 5" x 8" format and also enlarged them up to 32" x 24".

6. Investigations should be conducted to determine which map products can be made using conventional films (without conducting layers).

7. Application of EBR technology to wideband image and data recording should be investigated.

Section 5.0 Bibliography

1. "Production Specifications for USAF F-106/MA-1 AWCIS Cartographic Support Material," RM-26, July 1972.
2. "Symbols for Large Scale Maps," AMS Technical Manual No. 23A, Army Map Service, Stock No. 204781, February 1956.
3. "Flip Compilation Tolerances," "Flip Color Separation Tolerances," and "Projection and Grid Tolerances," from ACIC Manual No. 74-1, October 1969.
4. "U.S. Government Specifications, Low Altitude Instrument Approach Procedures," Interagency Air Cartographic Committee (IACC), No. 4, July 1971.
5. Sample "Flip Chart" publication, "Low Altitude Instrument Approach Procedures East United States," Vol. 8, Defense Mapping Agency Aerospace Center, St. Louis, Mo., January 1974.
6. Sample "DOD Flip Low Altitude High Speed Training Route Chart - Western U.S.," Scale 1" = 30 NM, Defense Mapping Agency Aerospace Center, St. Louis, Mo., January 1974.
7. "DOD Flight Information Publication (Terminal), High Altitude Approach Procedures World-Wide," RM-91, Defense Mapping Agency Aerospace Center, St. Louis, Mo., July 1972.
8. E.P. Devine, Office of Aeronautical Charting and Cartography, NOAA/NOS, U.S. Department of Commerce, "System M. A Proposed Method for Producing Aeronautical Charts Using Computer Output Microfilm," presented at 6th International Cartographic Association Conference, Ottawa, Canada, August 1972.
9. Sample "NOAA Flip Enroute Low Altitude - U.S.," Scale 1" = 10 - 12 NM, Interagency Air Cartographic Committee, Defense Mapping Agency Aerospace Center, St. Louis, Mo., January, 1974.

10. "Investigation, Experiments, and Study of Electron Beam Recorder (EBR) Techniques for Map Production, Technical Report ETL-CR-73-15, USAETL Contract No. DAAK02-72-C-0425.
11. "To Add a Graphics Arts Character Generation Capability to the Present Study of Electron Beam Recorder (EBR) for Map Production," Technical Report ETL-CR-74-12, USAETL Contract No. DAAK02-73-C-0211.
12. "Graphic Arts Symbol Generating Hardware for a Gerber Plotting System," Technical Report ETL-CR-74-14, USAETL Contract No. DAAK02-73-C-0310.
13. "Design and Development of Advanced Electron Beam Control System," Technical Report ETL-0032, USAETL Contract No. DAAK02-74-C-0410.
14. P.F. Grosso, "Application of Electron Beam Recording for Automated Cartography," International Conference on Automation in Cartography, Reston, VA, December 1974.
15. M.H. Gold, P.F. Grosso, A.A. Tarnowski, "Automated Electron Beam Recorder Cartographic/Graphic Arts Typesetting System for Production of Color Map Products," American Congress for Surveying and Mapping, Washington, D.C., September 1974.
16. P.F. Grosso, A.A. Tarnowski, "Recent Advances in Electron Beam Recording," J. Vacuum Technology, Vol. 10, No. 6, November/December 1973.
17. U.S. Army Mobility Equipment Research and Development Center RFQ DAAK02-75-Q-0777.
18. A.P. Colvocoresses, U.S. Geological Survey, "Evaluation of First Earth Resources Technology Satellite (ERTS-1) for Cartographic Application," International Society of Photogrammetry, Sweden, August 1974.
19. Earth Resources Technology Satellite Data Users Handbook, National Aeronautics and Space Administration, Greenbelt, Md, Document No. 71SD4249, 1972.

20. P. June Min, IBM, "Computer-Aided Mapping Technology for Geographic Data Base," Proceedings of SID, Vol. 14, No. 1, 1973.
21. R. Bernstein, IBM, "Scene Correction (Precision Processing) of ERTS Sensor Data Using Digital Image Processing Techniques," Third ERTS Symposium, NASA/GSFC, December 1973.
22. "Earth Resources Technology Satellite NASA Data Processing Facility Format and Content Specification for Computer Compatible Tapes," Goddard Space Flight Center, May 1972.
23. "Generation and Physical Characteristics of ERTS MSS System Corrected Computer Compatible Tapes," No. X-563-73-206, Goddard Space Flight Center, July 1973.
24. A.A. Tarnowski, "Large Format Wideband Electron Beam Recording," Electro-Optical Systems Design Conference, New York, September 1976.
25. P.F. Grosso, A.A. Tarnowski, "Application of Electron Beam Recording in Graphics," Electro-Optical System Design Conference, New York, September 1976.
26. P.F. Grosso, A.A. Tarnowski, "Cartographic Electron Beam Recording," 2nd Annual William T. Pecora Memorial Symposium on Mapping and Remote Sensing Data, Sponsored ASP, USGS, NASA, Sioux Falls, South Dakota, October 1976.
27. Physical and Chemical Behavior of Kodak Aerial Films - Kodak Publication M-63.
28. Physical Properties of Kodak Aerial Films - Kodak Publication M-62.

APPENDIX A

ENLARGEMENT OF CARTOGRAPHIC EBR IMAGE USING ETL
EXPERIMENTAL LASER PROJECTION PLATE MAKER

DEPARTMENT OF THE ARMY
UNITED STATES ARMY ENGINEER TOPOGRAPHIC LABORATORIES
FORT BELVOIR, VIRGINIA 22060

EXPERIMENTAL LASER PROJECTION PLATE-MAKER

THIS FLIP CHART OF THE SAN FRANCISCO INTERNATIONAL AIRPORT APPROACH WAS PRINTED FROM A LITHOGRAPHIC PLATE WHICH WAS EXPOSED ON AN EXPERIMENTAL LASER PROJECTION PLATE-MAKER AT THE U.S. ARMY ENGINEER TOPOGRAPHIC LABORATORIES (USAETL), FORT BELVOIR, VIRGINIA.

PROJECTION WAS DONE AT APPROXIMATELY 4.3X MAGNIFICATION FROM A 70mm FILM CHIP WHICH WAS PRODUCED FROM DIGITAL INPUT TO THE USAETL ELECTRON BEAM RECORDER (EBR). THE 70mm FILM FORMAT WAS ILLUMINATED BY SWEEPING THE LASER BEAM (LEXEL MODEL 85 ARGON) WITH AN X-Y GALVANOMETER MIRROR SYSTEM.

THE PLATE IS KODAK "KRL-X" PRE-PROTOTYPE MATERIAL WHICH IS SENSITIVE INTO THE VISIBLE SPECTRUM. EXPOSURE WAS EQUIVALANT TO 10 MILLI-JOULES/CM² FOR 60 SECONDS.

THIS WORK IS BEING CARRIED ON TO DEVELOP TECHNIQUES AND HARDWARE TO CONVERT EBR FILM CHIPS DIRECTLY TO FULL-SIZE PRESS PLATES IN ONE STEP. A POSSIBLE CONFIGURATION WOULD BE TO RECORD 49 FLIP-CHART PAGES ON A 5"x8" EBR CHIP AND PROJECT IT AT 7X MAGNIFICATION ON A LASER PROJECTION PLATE-MAKER TO PRODUCE A PLATE FOR PRINTING THE 49 PAGES WITH ONE PRESS PASS.

FUTURE WORK AT USAETL WILL BE DIRECTED TOWARD TESTING THIS CONCEPT AND IN TESTING LASER PLATE MATERIALS AS THEY BECOME AVAILABLE.

FEBRUARY 1977

VOR RWYS 28L&R

AL-375 (FAA)

SAN FRANCISCO INTERNATIONAL
SAN FRANCISCO, CALIFORNIA

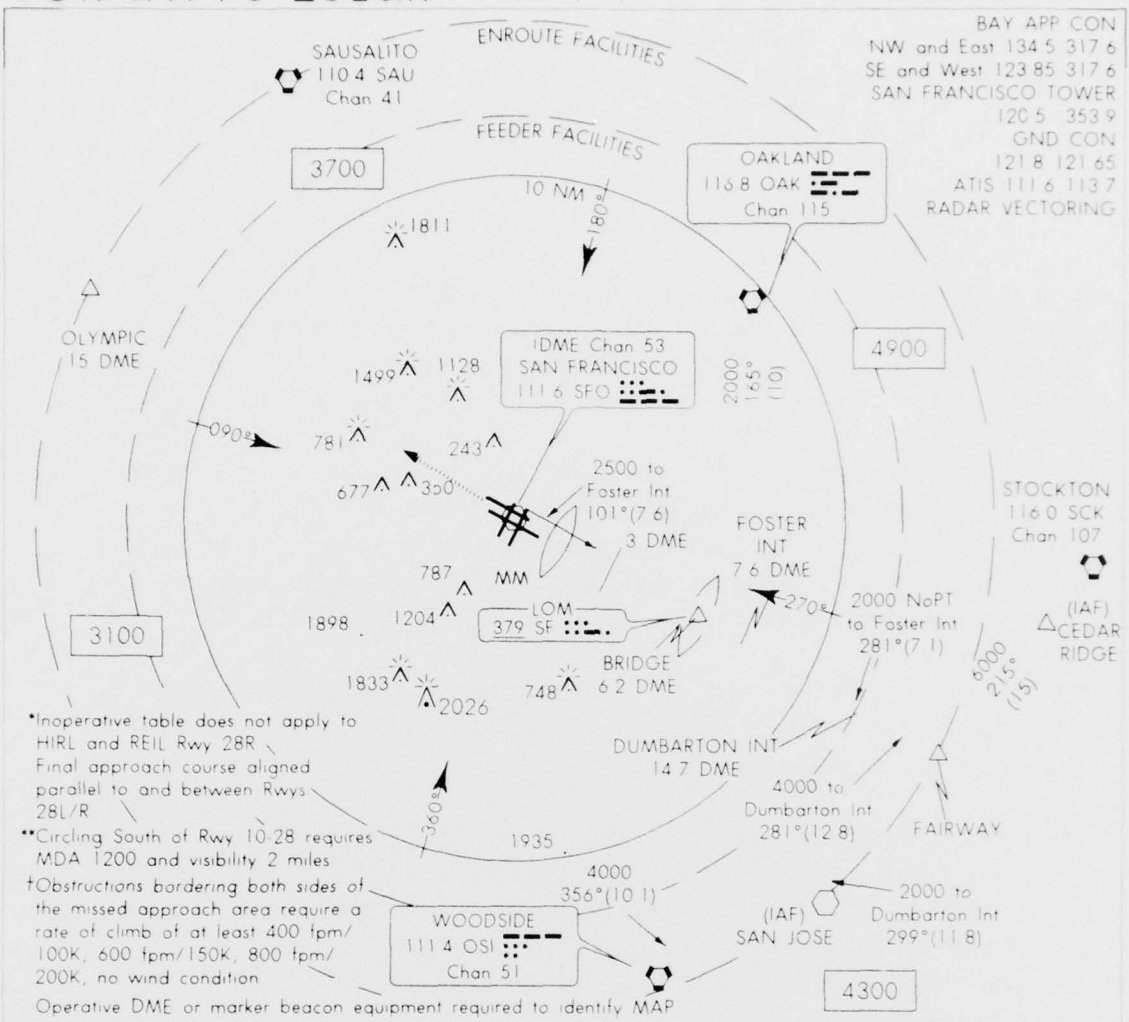

BAY APP CON
NW and East 134.5 317.6
SE and West 123.85 317.6
SAN FRANCISCO TOWER
120.5 353.9
GND CON
121.8 121.65
ATIS 111.6 113.7
RADAR VECTURING

*Inoperative table does not apply to HIRL and REIL Rwy 28R. Final approach course aligned parallel to and between Rwy 28L/R.
**Circling South of Rwy 10-28 requires MDA 1200 and visibility 2 miles.
†Obstructions bordering both sides of the missed approach area require a rate of climb of at least 400 fpm/100K, 600 fpm/150K, 800 fpm/200K, no wind condition.
Operative DME or marker beacon equipment required to identify MAP

CATEGORY	FOSTER INT 7.6 DME			
	A	B	C	D
S-28L	580/24	570 (600-1/2)		580/60 570 (600-1/4)
S-28R*	580/50	571 (600-1)	580-1 1/2 571 (600-1/2)	580-2 571 (600-2)
CIRCLING**	580-1	570 (600-1)	660-1 1/2 650 (700-1/2)	660-2 650 (700-2)
DME MINIMA				
S-28L	440/24	430 (500-1/2)		440/50 430 (500-1)
S-28R*	440/50	431 (500-1)	580-1 1/2 571 (600-1/2)	580-2 571 (600-2)
Knots				
Min Sec				

VOR RWYS 28L&R

37°37'N-122°23'W

SAN FRANCISCO, CALIFORNIA

SAN FRANCISCO INTERNATIONAL

2 MAY 1974

PUBLISHED BY NDS, NOAA, TO IACC SPECIFICATIONS

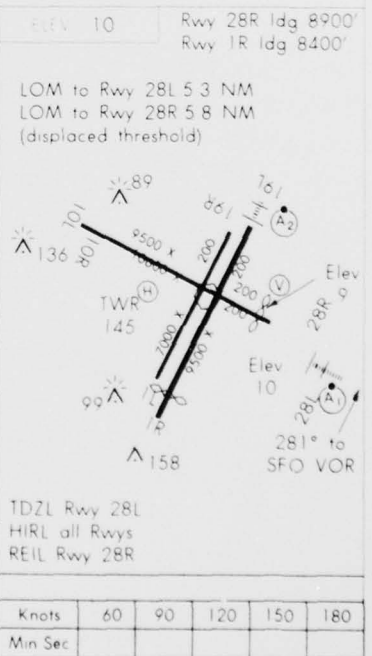

 **Image Graphics, Incorporated**
1525 KINGS HIGHWAY, FAIRFIELD, CT. 06430 (203) 333-7918