

AD-A044 407

ARMED FORCES COMMUNICATIONS AND ELECTRONICS ASSOCIATI--ETC F/G 17/2
PROCEEDINGS OF THE ANNUAL SEMINAR (2ND). THE ART OF COMMUNICATI--ETC(U)
SEP 77 S KREVSKY
AFCEA-FM-2

UNCLASSIFIED

NL

AD
AO44407
OF 2



44407

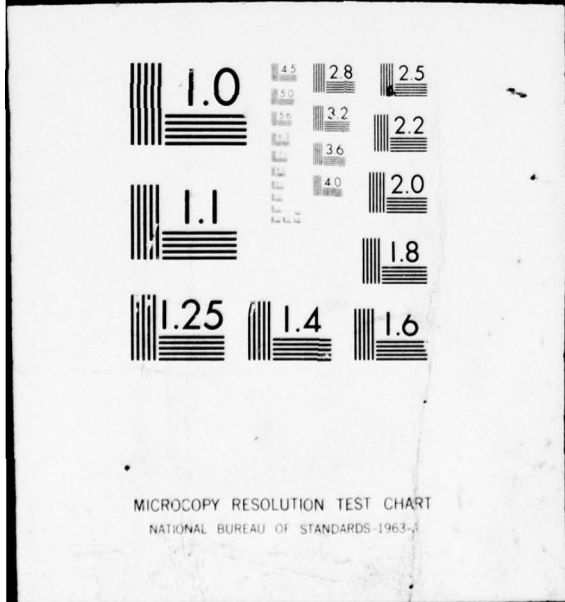

P

ARMED FORCES COMMUNICATIONS AND ELECTRONICS ASSOCIATION

FORT MONMOUTH CHAPTER

AD A 044407

See 1473

PROCEEDINGS
OF THE
SECOND ANNUAL
SEMINAR



DDC
SEP 22 1977
C

AD No. _____
DDC FILE COPY

"THE ART OF COMMUNICATIONS INTERFACES"

15 SEPTEMBER 1977

DISTRIBUTION STATEMENT A
Approved for public release;
Distribution Unlimited

ARMED FORCES COMMUNICATIONS AND ELECTRONICS ASSOCIATION
FORT MONMOUTH CHAPTER

PROCEEDINGS
OF THE
SECOND ANNUAL
SEMINAR ~~(Second)~~

"THE ART OF COMMUNICATIONS INTERFACES"

15 SEPTEMBER 1977

P.O. BOX 805
EATONTOWN, NEW JERSEY 07724

APPROVED FOR PUBLIC RELEASE
DISTRIBUTION UNLIMITED

DISTRIBUTION STATEMENT A
Approved for public release;
Distribution Unlimited

PROCEEDINGS INFORMATION

Responsibility for the contents rests upon the authors and not the Seminar Committee or its members. After the Symposium, all the publications rights of each paper are reserved by their authors, and requests for republication of a paper should be addressed to the appropriate author. Abstracting is permitted and it would be appreciated if the Seminar is credited when abstracts or papers are republished. Requests for individual copies of the papers should be addressed to the authors. Extra copies of the proceedings may be obtained from the Seminar Chairman. Requests should include a check for \$15.00 per copy, made payable to the "Fort Monmouth Chapter, AFCEA". Copies may also be obtained for a nominal fee from the National Technical Information Service (NTIS), Operations Division, Springfield, Virginia 22151.

Proceedings of the first annual seminar are available from the Defense Documentation Center, Cameron Station, Alexandria, Virginia 22314. The document number is AD-A023907.

SEYMOUR KREVSky
General Manager and Editor

MESSAGE FROM THE GENERAL CHAIRMAN

We of the Fort Monmouth Chapter of AFCEA are delighted to host the second annual seminar on "The Art of Communications Interfaces" and trust that today's presentations and discussions will bring us closer to a technical and operational understanding of where we are in the state of this art.

More than ever, the interfaces among communications systems are crucial to the timely and accurate transmission of the highly sensitive command, control and intelligence information needed to win battles and wars. This is as true for the peace time detente situation as it is for the nuclear hot war armageddon. It is in this context that the subject of communications interfaces is so vital to the national command authorities. This seminar presents 10 papers on important aspects of tactical and strategic communications systems interfaces.

The Fort Monmouth Chapter is very grateful for the time and effort put into the promulgation of this seminar by the Generals Paschall, Hoover, Hilsman and Paige and for the speakers and their respective organizations and of course to the Chapter Staff for their untiring efforts and devotion.

Your dialog discussions and comments are highly appreciated in improving the seminar as a forum and suggestions for future topics are also most welcome.

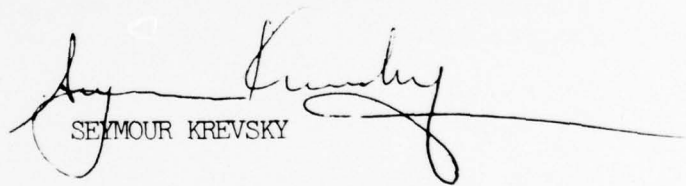
SEYMOUR KREVSKY

ACCESSION for	
✓	✓
✓	✓
✓	✓
✓	✓
BY	
DISTRIBUTION/AVAILABILITY CODES	
DIST.	SPECIAL
A	

GENERAL CHAIRMAN



SEYMOUR KREVSKY

Seymour Krevsky was born on 2 July 1920 in Elizabeth, New Jersey. He received the BS in EE degree from the Newark College of Engineering, Newark, New Jersey in 1942 and the MS in EE in 1950.

Mr. Krevsky's career has included mobile radio project engineering with the Signal Corps Engineering Laboratories in Fort Monmouth from 1942 to 1944 and 1946 to 1950 with a gap for military service with the Army Air Corp's Air Technical Service Command at Wright Patterson Air Force Base, Dayton, Ohio. From 1950 to 1959 he was Chief, Microwave DF and Antenna Section of the SCEL Countermeasures Division. Mr. Krevsky joined RCA's Advanced Communications Laboratory in New York City from 1959 to June 1968 and returned to Fort Monmouth in June 1968 to the position Deputy Director of the Engineering Directorate of US Army Communications Systems Agency. Currently he is Chief of the Transmission Division of the Product Manager for DCS Army R&D Systems in USACSA.

He is a senior member of the Institute of Electrical and Electronics Engineers and a past President of the New Jersey Coast Chapter. He is President of the Fort Monmouth Chapter of AFCEA and a Fellow of the American Association for the Advancement of Science.

TECHNICAL CHAIRMAN



BERNARD D. DE MARINIS

Mr. De Marinis is a Project Engineer at Booz, Allen Applied Research. He has more than nine years of professional experience in fiber optics, satellite communications systems, digital tropospheric systems, down-the-hill communications, and ECM systems. He has been extensively involved with military inventory radio equipment assemblages and their tactical and strategic communications interfaces.

Mr. De Marinis received his B.F.E. degree from the City College of New York and his M.S.E.E. degree from the Polytechnic Institute of Brooklyn. He has also completed the major portion of the course requirements for a Masters Degree in Business Administration from Fairleigh Dickinson University.

Mr. De Marinis has been an officer of the Microwave Theory and Techniques, Antennas and Propagation, and Circuit & Systems groups of the IEEE and was chairman of the 1976 International Microwave Symposium. He is presently Vice Chairman of the Princeton Section IEEE and is a member of AFCEA, the Association of Old Crows, ADPA, Tau Beta Pi, and Eta Kappa Nu.

LUNCHEON CHAIRMAN



DANIEL A. PETERSON

Mr. Peterson is the Regional Marketing Manager for GTE Sylvania Incorporated, a position he has held for the past three years.

A native of Portage, Wisconsin, he received a BSEE degree from the University of Wisconsin, and did graduate work in Electrical Engineering and Physics at the University of Michigan and Columbia University.

He entered the Regular Officers Corps of the US Army in 1950, after being designated DMG from the ROTC program. His service in the Signal Corps included a Communications Officer in the Korean War, Instructor in the Department of Electricity of the US Military Academy, and on two separate occasions an instructor here at Fort Monmouth in the Officers Department of the Signal School.

During his twenty years in industry, he has served in many engineering and marketing management positions with RCA, Motorola and GTE Sylvania.

He is currently Vice President of Programs for the Fort Monmouth Chapter, AFCEA; Secretary of the Industrial Representatives Association and is a member of IEEE, AUSA, AAAA and Old Crows Associations.

He resides in Colts Neck, New Jersey with his wife and three children.

LUNCHEON SPEAKER



LIEUTENANT GENERAL LEE McQUARTER PASCHALL

Lieutenant General Lee McQuarter Paschall was born in Sterling, Colo., on January 21, 1922, and graduated from Phoenix Union High School in Phoenix, Arizona in 1939. He attended the University of Alabama and obtained a BA in History in June 1957. Later he attended the George Washington University and received the MA degree in International Affairs in June 1964.

His commands include the UK Communications Region (AFCS) and Deputy Director of Command Control and Communications and Director July 1971. He assumed duties as Director DCA on 30 July 1974.

As Director, General Paschall is responsible for the management and direction of the worldwide Defense Communications System. He is also responsible for the system engineering and technical support to the National Military Command System and for provision of technical support to the worldwide military command and control standard automatic data processing systems. In his capacity as Manager, National Communications System, he is responsible for providing effective direction to the worldwide National Communications System, which includes the communications facilities of the various Federal agencies. The Director, DCA, is also Chairman, Military Communications-Electronics Board, providing a liaison point for joint and international communications matters.

General Paschall is married to the former Bonnie Edwards of Denver, Colo. They have three children: Patricia Ann Grillos, Stephen L., and David E.

INTRODUCTIONS

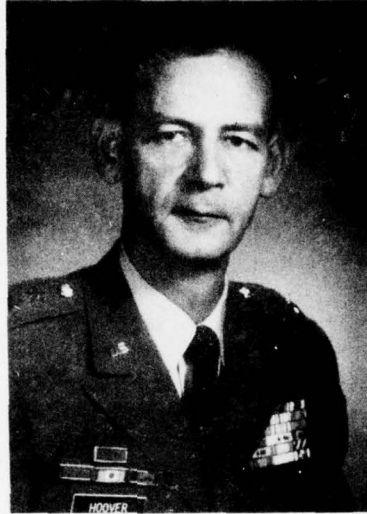

MAJOR GENERAL JOHN ELWOOD HOOVER

John E. Hoover was born in Timberville, Virginia, 28 April 1924. He enlisted in the Army in 1942 and, after serving 18 months as an enlisted man in the Signal Corps, was discharged to enter the US Military Academy, West Point, New York. Upon graduation in 1947, he was commissioned a 2nd Lieutenant, Signal Corps, in the Regular Army.

In 1953 General Hoover was assigned to Washington, DC where he attended Georgetown University, graduating with a Masters Degree in International Relations in 1955. From 1955 to 1958 he was a member of the faculty of the Department of Social Sciences at the US Military Academy.

His commands include 29th Signal Battalion, HQ, US Army Europe; CO, Regional Communications Group, 1st Signal Brigade in Vietnam 1969; Director Communications Systems and Deputy Assistant Chief of Staff for CE in 1973.

In August 1973, General Hoover assumed duties as the Deputy Commanding General, US Army Communications Command, Fort Huachuca, Arizona, leaving that position to become Director, Joint Tactical Communications Office, Office of Secretary of Defense (TRI-TAC), Fort Monmouth, N.J. in August 1974.

General Hoover is married to the former Mary Jo Cox of Vienna, Georgia. They have two daughters, Mary Kathryn and Holly.

STRATEGIC SESSION CHAIRMAN



BRIGADIER GENERAL EMMETT PAIGE, JR

Brigadier General Emmett Paige Jr. was born on 20 February 1931 in Jacksonville, Florida. He received a BA degree in Business Administration from the University of Maryland and the Master of Public Administration Degree from Pennsylvania State University. He attended the Signal School, Basic and Advanced Courses, US Army Command and General Staff College and the Army War College. His assignments include project officer in the UNICOM Systems Office 1966, Deputy Proj Manager for IWCS 1968, Chief Voice Network Global Management Branch, Operations Directorate DCA, 1973, Deputy Chief of Staff, Army Communications Command, Fort Huachuca, AZ 1974, Commander 11th Signal Group, US Army Communications Command 1975 and Commanding General US Army Communications Systems Agency/and Project Manager DCS Army Communications Systems/Commander, US Army C-E Engineering Installation Agency in 1976.

He has been awarded the Joint Service Commendation Medal, The Bronze Star, The Meritorious Service Medal, the Army Commendation Medal and the Legion of Merit with two Oak Leaf Clusters.

TACTICAL SESSION CHAIRMAN



MAJOR GENERAL WILLIAM JOSEPH HILSMAN

Major General William J. Hilsman was born on 13 March 1932 in St. Louis, Missouri. He is a graduate of the US Army Military Academy and Command and General Staff College. He also has an MS in EE degree from North-eastern University. He has wide experience in Management Information Systems, having been Chief, Scientific Engineering Evaluation Division of the Information and Data Systems Command 1965, Signal Systems Plans Officer, Management Information Systems Officer 1968, Assistant Vice Chief of Staff, US Army, and Advisor to Director MIS, Office of Assistant Vice Chief of Staff. General Hilsman has commanded the 1st Signal Group Fort Lewis, Washington 1973 to 1975 and in Fort Monmouth was Project Manager, Army Tactical Data Systems (ARTADS) and Acting Commander of CORADCOM until this later year when he assumes his new Command as Commander, US Army Signal Center and School at Fort Gordon, Georgia.

RESERVATIONS CHAIRLADY



MRS. BARBARA ANN FISCHER

Mrs. Fischer is Administrative Assistant at the Regional Marketing Office of GTE Sylvania's Electronic Systems Group. She has been with GTE Sylvania for 15 years in the local office.

She received an AA degree from Brookdale College, Lincroft and attended Monmouth College, West Long Branch, New Jersey.

She is currently Meeting Arrangements Coordinator for the Fort Monmouth Chapter of AFCEA and Registrar for the Chapter's Second Annual Seminar. She is a member of AFCEA and AUSA and has received several Honor Awards from the Chapters in the past ten years.

Mrs. Fischer resides in Middletown, New Jersey with her husband.

TABLE OF CONTENTS

TECHNICAL PROGRAM

	<u>PAGE</u>
MESSAGE FROM THE GENERAL CHAIRMAN, SEYMOUR KREVSKY.....	3
<u>SESSION I: STRATEGIC SYSTEMS INTERFACES</u>	
Chairman - BG Emmett Paige, Jr. CGUSACEEIA/PM, DCS (ARMY) Communications Systems	
SYSTEM ENGINEERING FOR THE DEFENSE COMMUNICATION SYSTEM Mr. Gilbert E. LaVean, Associate Director for Engineering Planning, DCEC.....	15
ACCESS AREA SWITCHING SYSTEMS Mr. Leo H. Wagner, Chief Switching Division, Product Manager R&D DCS Army, USACSA.....	39
NEW INTERFACES FOR UPGRADING AUTODIN II SERVICES Mr. W. Scott McClary, Senior Member Technical Staff, Computer Sciences Corp., Falls Church, VA.....	59
DIGITAL TROPO MODEMS Mr. Walter Cybrowski, Senior Engineer, Communications Systems Laboratory (CORADCOM).....	65
THE COMBINED US/NATO DIGITAL TROPO TEST PROGRAM Mr. John Osterholz, Senior Engineer DCEC, Reston, VA.....	85
<u>SESSION II: TACTICAL SYSTEM INTERFACES</u>	
Chairman -MG William J. Hilsman, Command General CORADCOM	
THE USE OF GRAPHICS IN A TACTICAL ENVIRONMENT Mr. Leon Bloom, Manager Advanced Computer Systems, Litton Data Systems, Van Nuys, California.....	107
NEW TECHNOLOGY FOR PROGRAMMABLE INTERFACE SUBSYSTEMS FOR ARTADS AUTOMATIC TEST Mr. David M. Priestley, Engineer, RCA Automated Systems Division, Burlington, Massachusetts.....	111

TABLE OF CONTENTS (cont'd)

PAGE

COMMAND AND CONTROL SYSTEM APPLICATIONS FOR TRI-TAC USING DEMAND ASSIGNED MULTIPLE ACCESS TECHNIQUES Mr. D. W. Horner, Senior Communications System Engineer, Motorola Inc., Scottsdale, Arizona.....	123
ARCHITECTURAL IMPACT OF FIBER OPTICS ON FUTURE MILITARY SWITCHING SYSTEMS. Dr. Edmund A. Harrington, Senior Systems Scientist, GTE Sylvania, Eastern Div., Needham, Massachusetts.....	135

SYSTEM ENGINEERING FOR THE DEFENSE COMMUNICATIONS SYSTEM

G. E. LaVEAN
Associate Director for Engineering Planning
Defense Communications Engineering Center
1860 Wiehle Avenue
Reston, VA 22090
(703) 437-2332

Abstract

The Defense Communications System (DCS) is an integral part of the Worldwide Military Command and Control System (WWMCCS) and as shown in Figure 1, the DCS provides the principal connectivity between the National Command Authorities (NCA) and the elements of the Armed Forces. It, thus, provides most of the long distance or long haul communications for the Defense Department. This paper discusses the DCS as it exists today, and how we plan to change the DCS, in the 1985 timeframe, to be responsive to the WWMCCS requirements.

Introduction

The current system today, the DCS, is a worldwide system. As shown in Figure 2 it extends from the Continental United States (CONUS) to Europe and beyond into Turkey, it can also serve parts of Africa. It connects CONUS with the Far East, Taiwan, the Philippines, and beyond (the Indian Ocean area). Therefore, it is truly a worldwide long haul communications system. The concept of the DCS today is based on the utilization of the extensive public telephone service that exists throughout the world and has the characteristics shown in Figure 3. In cases where the commercial service is not adequate it is supplemented by Government owned facilities. This dependence on the public telephone service means extensive use of frequency division multiplex and analog switches. Because the DCS draws on such a rich transmission capability, the public telephone service throughout the world, it is quite survivable and can draw on the other available resources within these countries to provide alternate routes in case the primary should should fail. However, as a result of this dependence the capability to provide secure transmission and certain other military features is limited.

A typical communication system is depicted by Figure 4, as shown here the communications system takes advantage of a long haul pipe, indicated by the large black surface in the long haul section of the slide. The access areas are those regions where channels of the different subscribers are concentrated into groups and added together to take advantage of the long haul capability. The local loop region is generally where most of the subscribers are located, and they may enter the system, or take advantage

of the long haul facilities by several different means. They can either enter the long haul facilities directly, as dedicated users, or they can be combined with other subscribers by multiplex equipment into groups and then added into the long haul facilities, or concentrated by local telephone exchanges. A large trunking switch provides the highest degree of concentration. This can be accomplished for both voice circuits, as with the AUTOVON system, or with digital circuits as in the AUTODIN system, the digital network, where store and forward switches are used. The name of the game then is to utilize the available resources in the most efficient way. This is accomplished by taking advantage of the statistics that are available due to the fact that subscribers do not normally desire an end-to-end connectivity to the same destination all the time. Therefore, it is possible to share these resources among the different subscribers, and reduce the cost to each individual subscriber with the penalty that he may find the transmission facility busy at certain times.

DCS Today

There are principally two ways of combining subscribers. It is accomplished either by a multiplex, which does it on a fixed basis, or on a call-by-call basis by a switch. Therefore, the way the economies are obtained is determined by the multiplexing and switching structure that is used in the system. Figure 4 doesn't indicate whether the switches or the multiplex are digital or analog, but currently the system is implemented with analog switches and analog multiplex. In the future they are to be replaced with digital multiplex and digital switches.

Since the basic 4kHz analog voice circuit can be assigned permanently, as with multiplex, or it can be dynamically switched as with the circuit switch, and those circuits are called either dedicated or switched depending upon which category they fall into. In the DCS today essentially 45 percent of the traffic is dedicated and 55 percent is switched.

Figure 5 shows a typical system structure within the current DCS network where the FDM multiplex equipment forms groups and super groups and is then sent on out over the transmission media. Circuit switches essentially switch a trunk voice channel between different subscribers. Store and forward switches take digital inputs and store them until a channel becomes available to the next point in the trip to the end user.

The basic 4kHz voice circuit can be used in many ways and has been taken advantage of by different techniques. It can be used for voice, or teletype, or data up to 9.6Kbs which has many applications including tying computers together or remote terminals for computers. The standard voice channel can also carry several teletype channels that have been multiplexed or it could be used for facsimile or telemetry.

Transition to Digital DCS

If analog circuits are so good and so flexible why then should we want to change to digital circuits? A few of the most important reasons why we chose to upgrade or change the DCS to a digital system are discussed in the following paragraph. First, a major military consideration is security, and we have been examining ways to make the DCS more secure so the enemy is unlikely to gain any advantage by listening to our transmission. Also, the DCS would be a more flexible system if it could respond automatically and electronically as a result of different stimulus that might be imposed on the system. We are also faced by an increasing load of digital traffic as computers are utilized more throughout the military agencies. Also, some of our equipment has become quite old and requires a significant expenditure to operate and maintain it, therefore, the new technology will allow us to reduce manpower. A major consideration is the real need to interoperate with the tactical digital networks deployed for combat forces. Interface problems will be drastically reduced if we maintain the same type of service and same system characteristics as we transition from one system to another.

The way to implement a new digital system is an evolutionary process, it is impractical to throw away everything that exists in the DCS today and start over with a new big digital system. Therefore, the strategy is to convert a segment of the system to digital and then go on to the rest of it. It makes sense then to start with the new upgrades that will be going into the transmission element of the system, when they are converted to digital it is relatively easy to install digital switches and to field a completely digital system in the future. Accepting the fact that there are going to be both analog and digital segments of the system co-existing at the same time, what would be the best analog to digital conversion technique? Having both types of facilities in the system strongly influences your decision. The factors that were considered to determine how to transition from an analog system to a digital system are as follows. Because many DCS circuits span thousands of miles and some extend ten thousand miles, it was necessary to make sure the long haul performance was maintained. It was also important to accommodate quasi-analog signals so they could traverse over the system without deterioration (e.g., 9.6 kbs modems). The availability of established technology was investigated to make sure the desired capability would be available in the proper timeframe. We also had to factor in the impact of squeezing the digital transmissions within the same bandwidths that the analog transmission had utilized. We also had to maintain a high degree transition flexibility.

These factors drove us to utilize the highest quality A-to-D conversion technique that could be effectively procured in the 1976 timeframe. This resulted in the selection of an 8 bit PCM type of A-to-D conversion for the transmission facilities. This has permitted the flexibility of performing the transmission upgrades one segment at a time since it is

possible to transform from analog to digital and back to analog and back to digital again without suffering significant degradation in the signals.

Figure 6 shows the wide range of signal inputs that could be expected to enter the PCM channel bank. The requirement is for an A-to-D conversion technique that can convert these signals to digital format and then back to the original analog format, at the distant end, with high fidelity. Other data streams may have been derived from digital telephones, computers, or even a packet type of terminal. They would be combined by a time division multiplex before going out to various means of transmission media.

An example of a more complex multiplex structure is shown in Figure 7. An analog signal passed through the PCM conversion process to become a digital stream. This output would then be added to several other converted FDM outputs so that this PCM box also performs the function of a multiplex. It A-to-D converts signals and develops a composite digital stream by placing the different subscribers in the time domain so that they can be properly extracted at the other end. To do this requires the PCM box to establish timing and framing. That output then is combined with other users of the TDM multiplex, again with the proper framing and structuring of the signals. Now it is possible to encrypt the digital stream and make it secure.

Once the capability to combine different types of digital streams has been established a philosophy on how to combine them is required. Questions to be resolved are: how many channels should be in each group, how often should you break out the groups, where should you use switches, and where you should use multiplex. So a multiplex hierarchy is developed with these parameters taken into consideration.

It is necessary to look at the location of the subscribers and the resulting capacity that is expected to be required between different locations. The A-to-D conversion technique determines the basic bandwidths involved and the transmission costs, but the number of channels is impacted by the tradeoff of switching versus allowing subscribers to be dedicated users. It is also necessary to examine the mix between digital traffic and analog traffic, and how much flexibility is required for adding new communities of users and adding other locations that might need service. The need to restore circuits and utilize alternate routes also impacts the multiplex structure.

Another significant issue is the number of and types of systems that are required to interface with the DCS and the importance of actually passing through that interface without decrypting, breaking down signaling structures. After looking at these factors, as they apply to the DCS, it was determined that a flexible hierarchy that allowed the DCS to interface with a wide range inputs and still be able to change configurations rapidly and reassign system capability to contingencies and new subscribers was needed.

Figure 8 shows the resulting DCS multiplex hierarchy starting at the sub-multiplex level, through a primary multiplex level and on up to a second level of multiplex. The resulting signal is provided to the modems and radios which adapt it to the transmission media. The sub-multiplex level combines teletypes or inputs from computers or facsimile. These are data streams which were less than 10Kbs. The primary multiplex level accepts data rates of 56Kbs or above or it could take groups of FDM subscribers and convert them into digital data streams. Typically the outputs of the primary multiplex level of hierarchy would be a T1 type carrier which is in the one and a half megabit region. The second level multiplex combines the T1 carriers into higher data rate streams, in the neighborhood of 10 megabits. These digital output streams are used to drive modems which are the devices that modulate the carriers of the transmitters.

Communications satellites fit into this transition philosophy very well since they allow connection between upgraded digital communities and other compatible communities wherever they might exist throughout the world. Thus, allowing the possibility to jump over or leapfrog geographical regions that are still analog. This is essentially tying together islands of digital service to form a digital system. And it also, of course, allows the flexibility to tie together networks of special users. For instance, a secure voice network or a computer network, could actually overlay the rest of the system and these subscribers treated as a special class of user. Satellites also permit the system to be reconfigured very rapidly so that resources can be reassigned to any position in the world.

Figure 9 shows a typical case where islands of digital service have been established in Korea, in Alaska, and at different locations in Europe. Rather than pass through A-to-D conversions to connect these islands by submarine cable to the United States it is very feasible to tie those islands directly to the United States utilizing satellites, and this application of satellites is shown in Figure 10. The DSCS, the Defense Satellite Communications System, provides global coverage and connects different communities of users directly back to the United States. By 1982 digital facilities in Europe are expected to extend from England down through Italy and to isolated digital islands in Greece and in Turkey. As shown in Figure 11 the satellite terminals provide connectivity into Greece and into Turkey even though they are not connected by terrestrial means. Also the satellite terminals provide the possibility to have local digital service in Spain and still be tied into the digital network even though there are no terrestrial digital transmission facilities that tie it directly to England or Germany. And, of course, the satellites provide an additional degree of survivability allowing the terrestrial backbone to be severed at any point and still be feasible to communicate with any portion of the system. Therefore, for survivability, transitional, and flexibility reasons it is important to have a satellite capability to augment our terrestrial facilities.

The Second Generation DCS

The second generation DCS then will have a very large digital element and the programs that will form the basis the second generation DCS will follow in the order shown on Figure 12. The first step is to perform the digital transmission upgrades, which would essentially convert the backbone of the DCS to digital. It would allow the DCS to accept both analog voice and digital inputs. When that is completed it would be possible to install secure voice switches, which would allow an automatic secure voice network, which is called AUTOSEVOCOM II. In addition to that the digital network for data, AUTODIN II, would be implemented. To help supplement those networks and to provide flexibility the DSCS Phase III, the third generation spacecraft, would be introduced. This capability will establish wideband digital service throughout the world. The next evolutionary step in this process would be the ability to integrate AUTODIN II and AUTODIN I to permit the combination of all digital traffic into one switching network called Integrated AUTODIN System (IAS). These programs and the timeframe they would occur are shown on Figure 12. Figure 12 indicates that by the 1983 timeframe it would be possible to have an operational second generation DCS.

Future DCS

The DCS doesn't stop there, we are also talking about a third generation DCS. In this case we are looking further into the future where the DCS would be providing service in the 1995 to 2000 timeframe. On the left of Figure 13 are the different services the DCS would provide and they go from teletype to wideband service. To satisfy those services today the DCS employs the AUTOVON analog system, a secure voice network and the AUTODIN digital network. The composition of the second generation DCS, of the 1985 era, was discussed previously and is shown between the years of 1985 and 1995, it is, of course, a highly digitized system. In the 1995 timeframe we see the third generation DCS and its principal features. First a distributed communications network, that has very little dependence upon the backbone, where the transmission facilities and switches are essentially distributed so that it is more survivable and less susceptible to single point failures. The other principal characteristic would be an integrated signaling structure. This is important to overcome the interoperability problems associated with interfacing with many different systems. This allows the DCS to essentially accept any signaling format or any signaling structure and retransmit it. It also means that the same resources can be used for different kinds of services, that is voice and data would be using the same transmission and switching facilities, therefore, the system would be very efficient.

Example of DCS System Engineering (AUTOSEVOCOM II)

One of the networks that will be part of the second generation DCS is of particular interest to us these days. That is the AUTOSEVOCOM II which

is the worldwide secure voice network we expect to have in the 1985 to 1995 timeframe. Figure 14 shows a typical network configuration for AUTOSEVOCOM II as it would be configured in the 1985 timeframe. The world is broken up into three regions--the CONUS or the US region, shown on the left; the overseas region, shown on the right; and a pie shaped section, shown in the top center which would indicate operational ships and aircraft, those subscribers who are generally considered to be in mobile platforms and have difficulty tying into fixed facilities. On the far right is a digital switch which is the TTC-39 or the TRI-TAC switch which is configured in this case to support the tactical users. It interfaces directly with the switch shown in the middle, which is a TCC-39 switch which is configured to support the DCS as opposed to a tactical set of users. On the far left is a switch that would be located in the United States and it is a modified ESS No. 1 switch and it is designed to emulate a TCC-39 switch. Therefore, these three different categories of switches with different problems involved in each. The AKDC is an automatic key distribution center and in case of the TTC-39 it is an integral part of the switch and in the case of ESS-1 it is an additional appendage. The AKDC is the system element that distributes the key automatically and electronically to the different subscribers so that the voice communications can be secure on a call-by-call basis. CB stands for conference bridge. Conference bridges should operate in the black or secure, the switches have analog subscribers and digital subscribers. There are very significant problems in developing a switch that adds many subscribers together and still does it in a secure mode. One of the more difficult problems is to tie together in the same conference, subscribers who are accessing over narrowband facilities and those who are entering over the wideband facilities. The quality that is normally afforded to a HF channel is quite poor and when it is added to the other subscribers who are of higher quality it can degrade the quality of the conference. Therefore, special techniques are required to combine these classes of users together. The ability to tandem wideband channels and a narrowband channel without degradation, is also a real challenge. To include these different classes of subscribers in the same system and have them all be able to play together and function properly is a real significant system design problem. The different end instruments and different interfaces are shown in Figure 14.

Conclusions

From the previous discussion it should be obvious that designing a worldwide communication system is a very complex problem and requires a great deal of knowledge of the components that make up the system. As you develop the system design it is necessary to perform tradeoff analyses between the cost and the optimum performance that is desired of the system, always looking for the best way to accomplish a particular function without increasing the cost beyond allowable limits. An important part of this, for a military system, is the ability to establish the proper network design that provides a highly survivable system but within the

the economic constraints. The good design is robust and allows the system to be severed at many points and still communicate satisfactorily. Other design criteria must be established by examining the missions the DCS must support and the specific user requirements. That is, in order to design the system it is essential to know what the users of the system really want and what they are willing to pay for a particular capability. Doing this requires developing different alternatives that possess a range of capabilities to tradeoff the different features, for instance, survivability versus flexibility or security versus flexibility, these features have to be examined and analyzed to assure the proper mix of each. Once the capabilities are designed into the system, it is essential to make sure the system is configured and utilized properly to take advantage of all the inherent capability. Therefore, system engineering for the DCS is a many faceted discipline that translates user needs into system alternatives and presents the performance of these alternatives, with related costs, in terms that can be understood by the decision makers. The capabilities, selected by the decision makers, are developed in sufficient detail to permit the implementing agencies to field a responsive subsystem that fits into the overall structure of the DCS. The system engineer also supports the operating system to insure proper system utilization, and identification of system deficiencies.

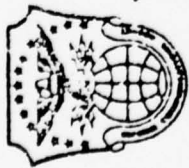

DEFENSE COMMUNICATIONS ENGINEERING CENTER

WORLDWIDE MILITARY COMMAND AND CONTROL NETWORK

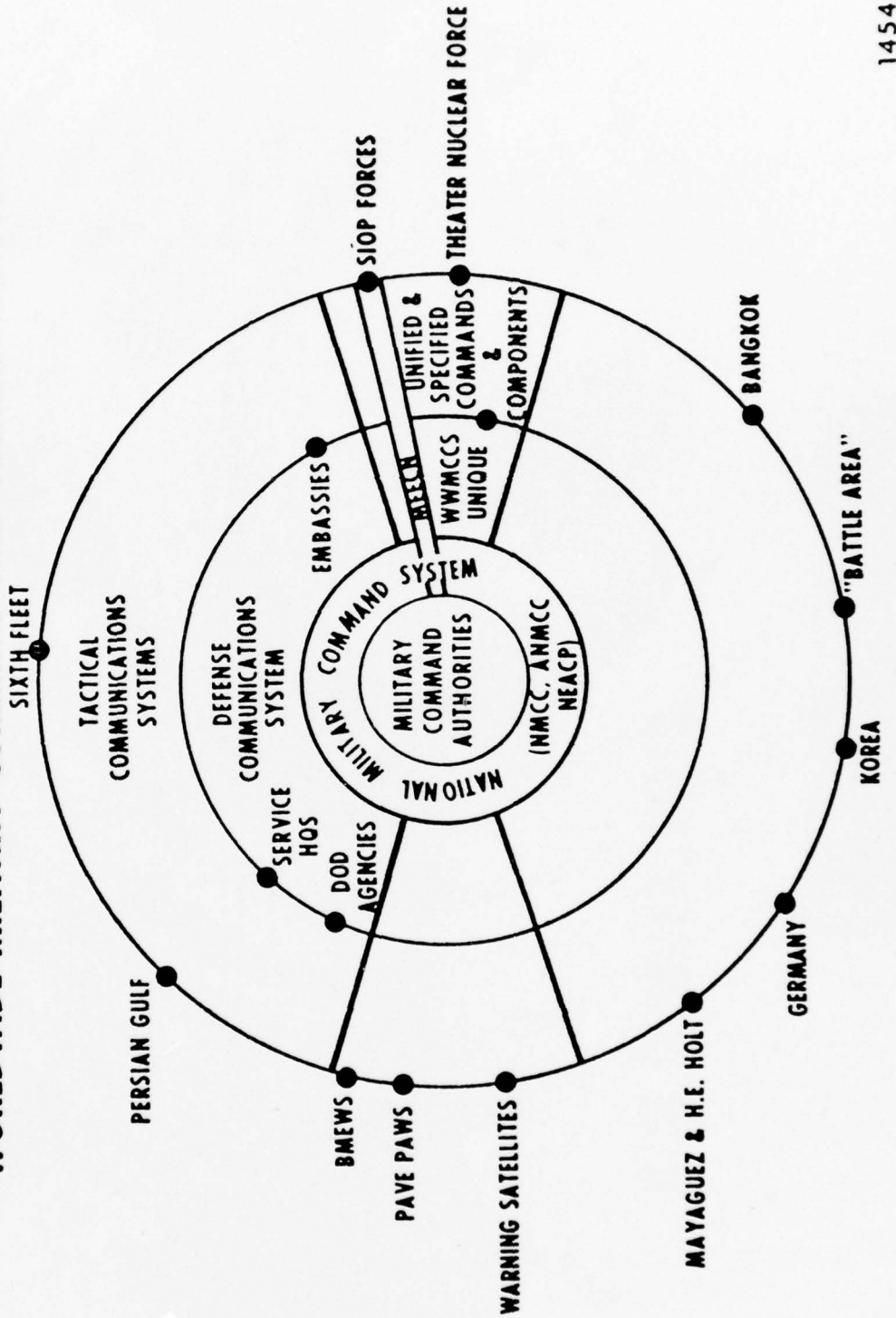

Figure 1

Figure 1

Department of Defense
DEFENSE COMMUNICATIONS AGENCY

DCS CONNECTIVITY

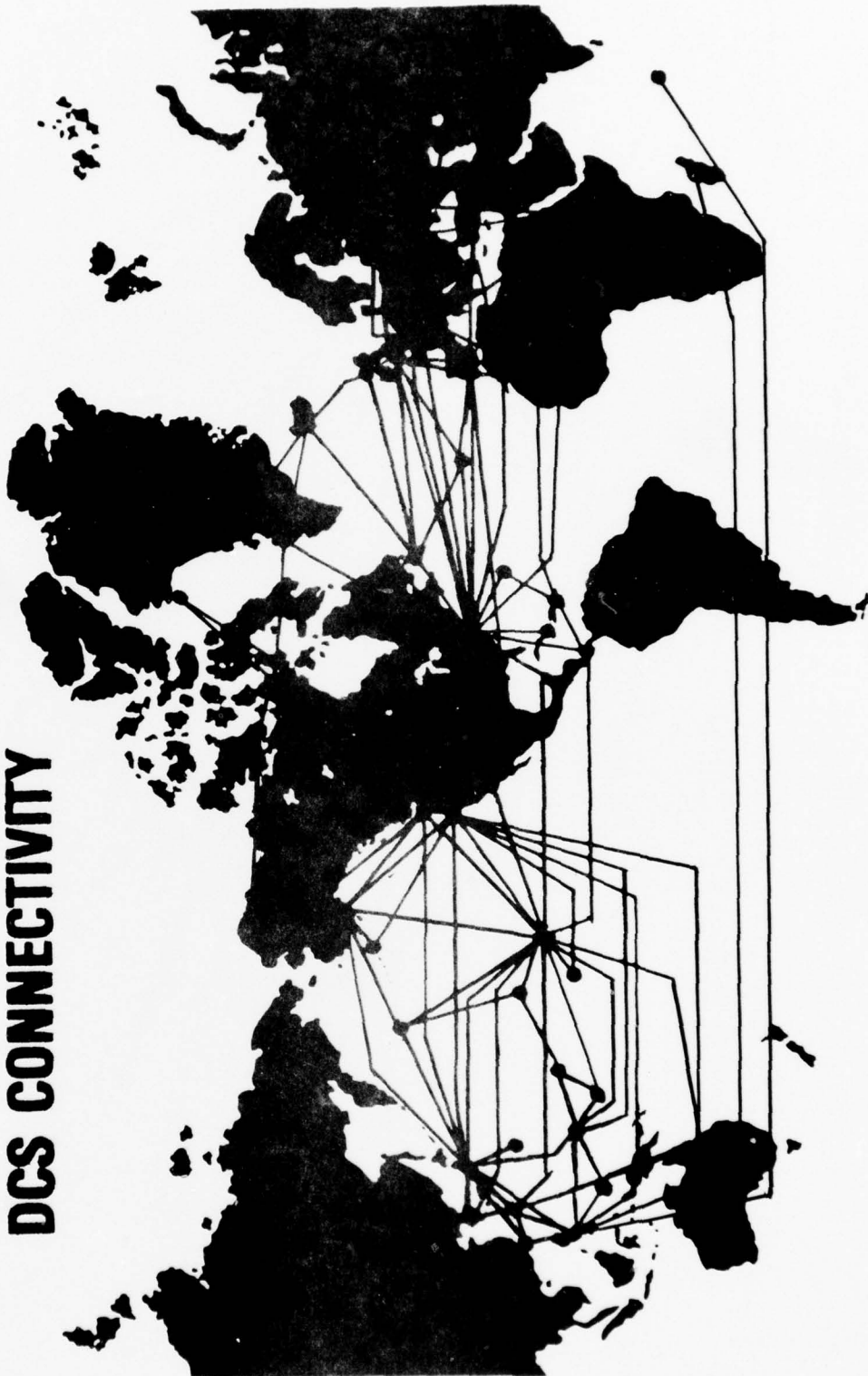

Figure 2



DEFENSE COMMUNICATIONS ENGINEERING CENTER

DCS TODAY

- CAPITALIZES ON EXTENSIVE PUBLIC TELEPHONE SERVICE
- SUPPLEMENTED WITH GOVERNMENT OWNED FACILITIES (AS NEEDED)
- EFFICIENT UTILIZATION OF THE TRANSMISSION RESOURCES ACHIEVED BY:
 1. FREQUENCY DIVISION MULTIPLEX (FDM)
 2. ANALOG SWITCHES (AUTOVON, AUTODIN*)
- FLEXIBILITY AND SURVIVABILITY ESTABLISHED BY AVAILABLE ALTERNATE ROUTING
- PROTECTED SERVICE IS LIMITED

* COMPUTER SWITCHING USING ANALOG CHANNEL



DEFENSE COMMUNICATIONS ENGINEERING CENTER

TRANSMISSION RESOURCES

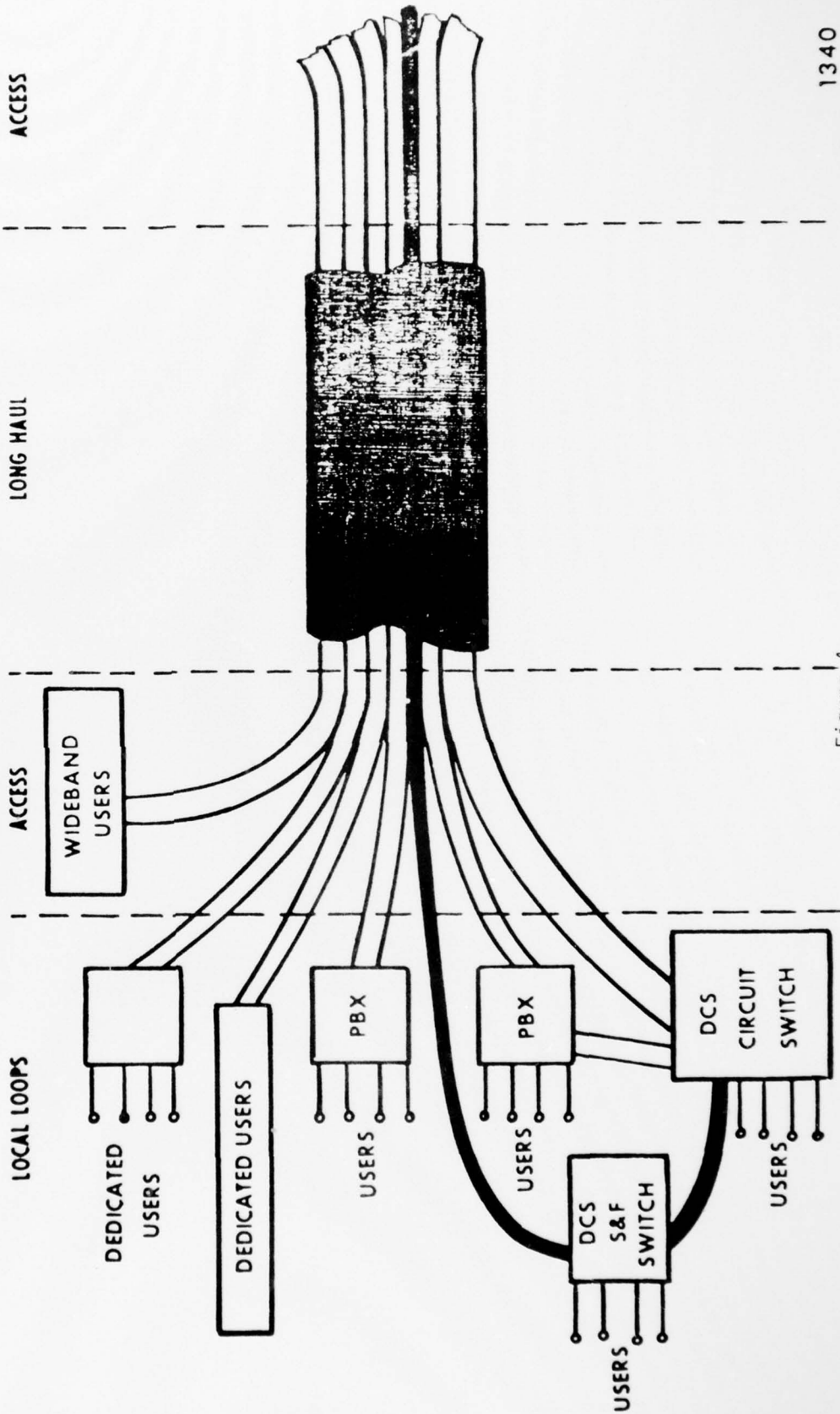

Figure 4



DEFENSE COMMUNICATIONS ENGINEERING CENTER

SWITCHED CIRCUIT

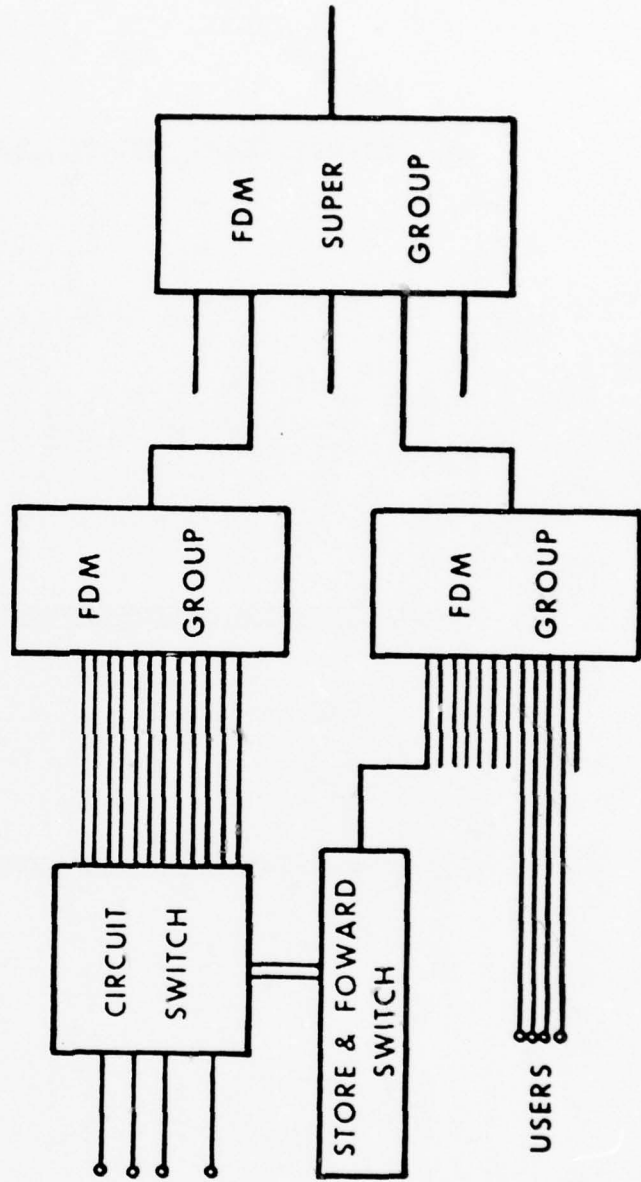

Figure 5



WHY PCM/TDM?

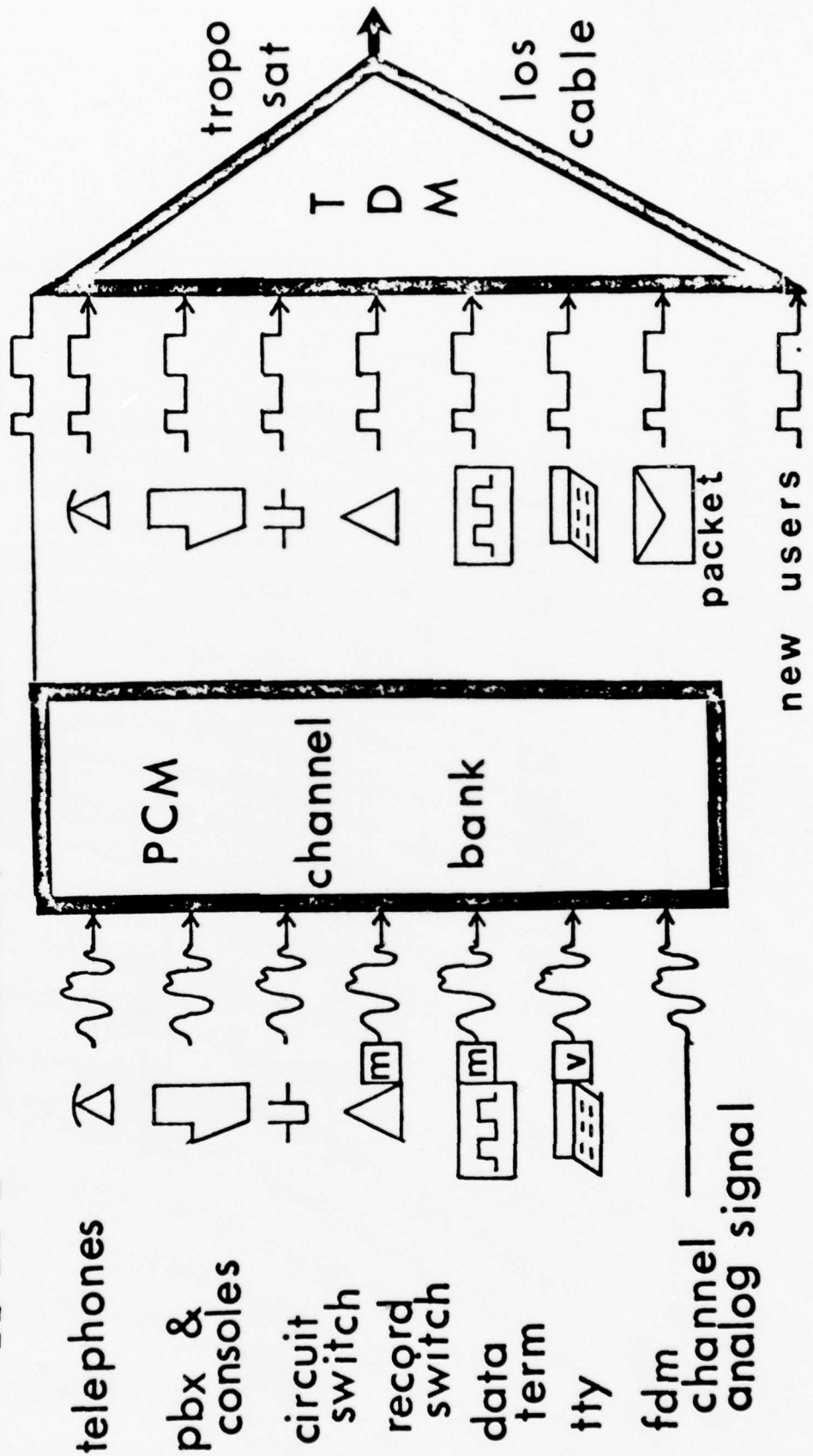
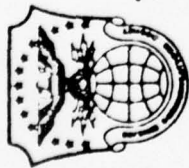

Figure 6



DEFENSE COMMUNICATIONS ENGINEERING CENTER

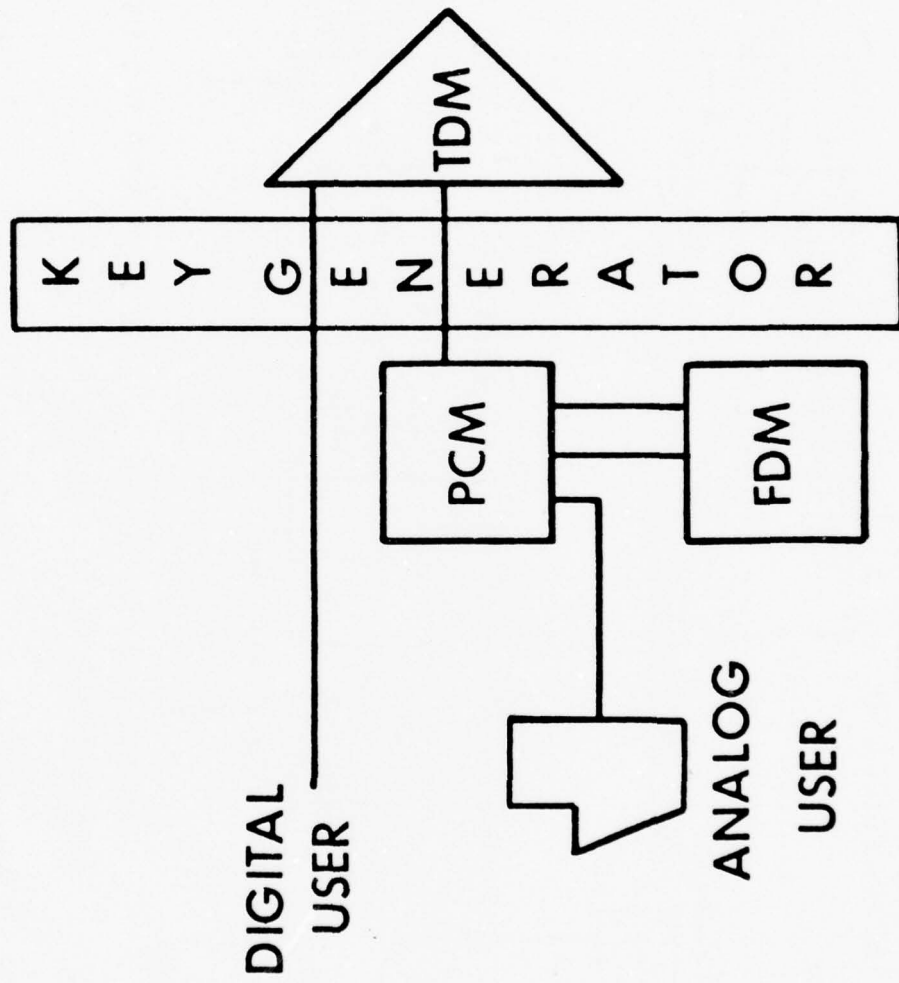

Figure 7

1982 DIGITAL TRANSMISSION SYSTEM CONFIGURATION

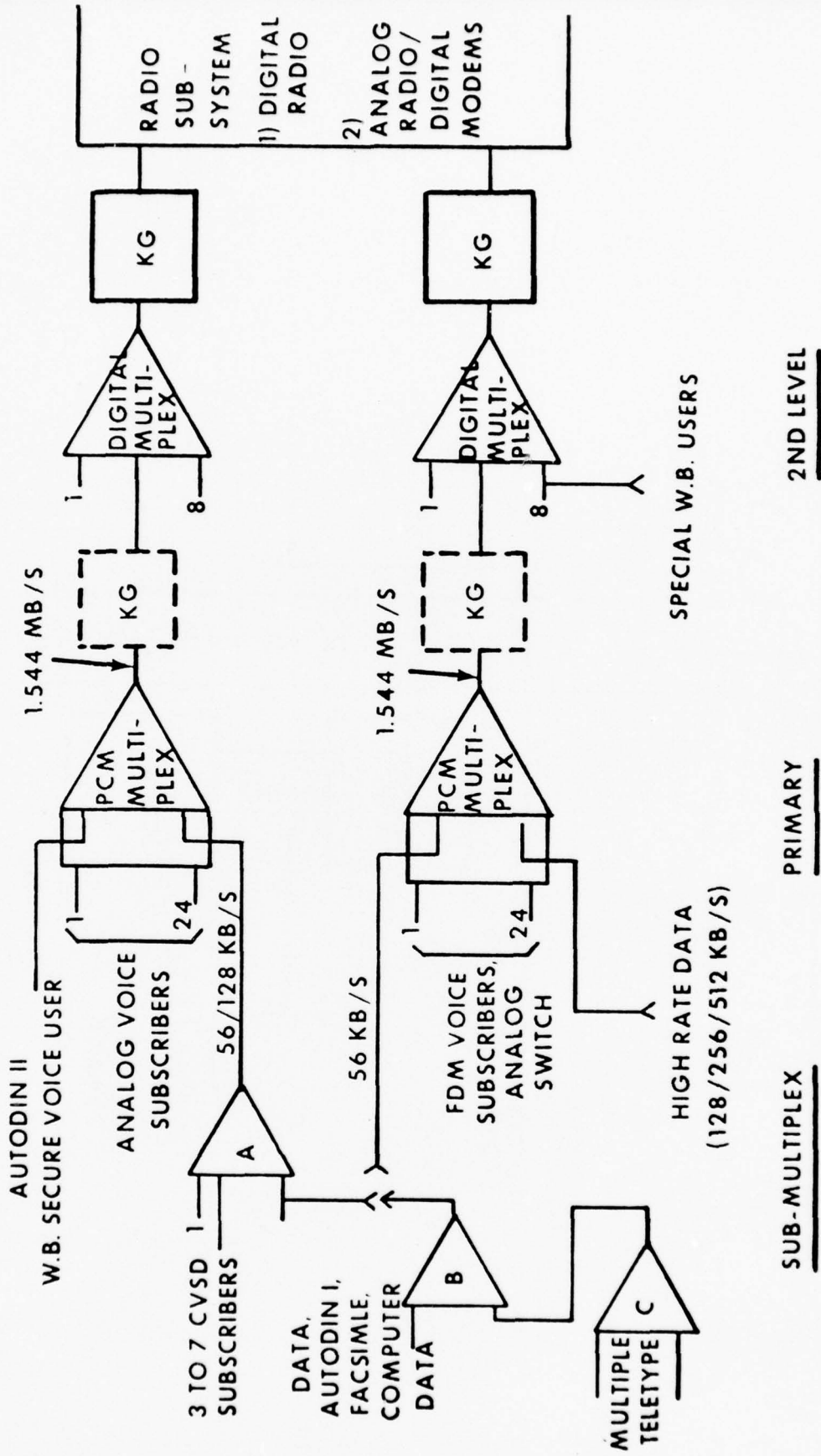
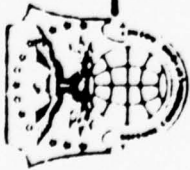

Figure 8

DEFENSE COMMUNICATIONS ENGINEERING CENTER



TYPICAL DIGITAL ISLANDS

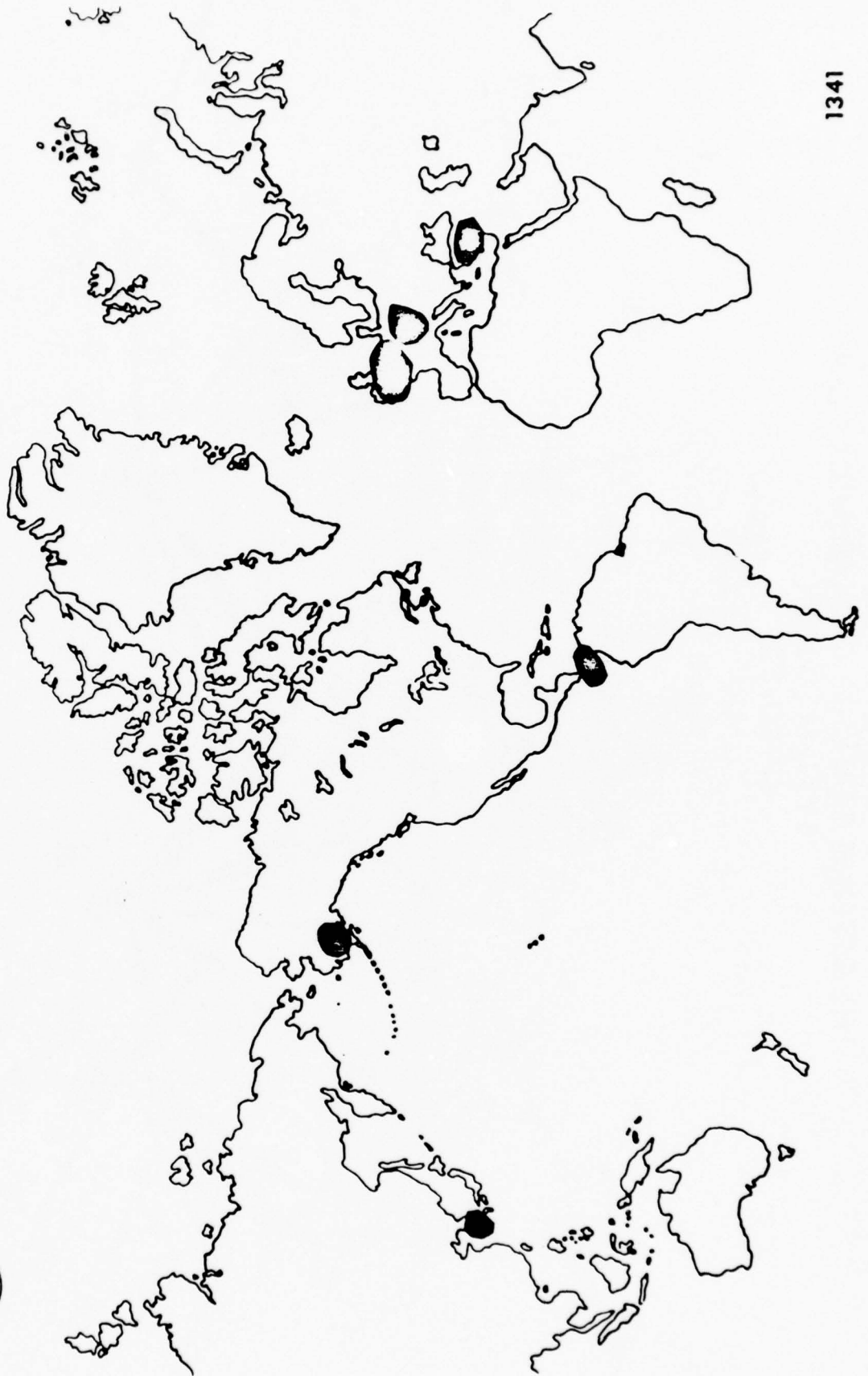

Figure 9

THE DEFENSE SATELLITE COMMUNICATIONS
SYSTEM (DSCS)
(1980-82)

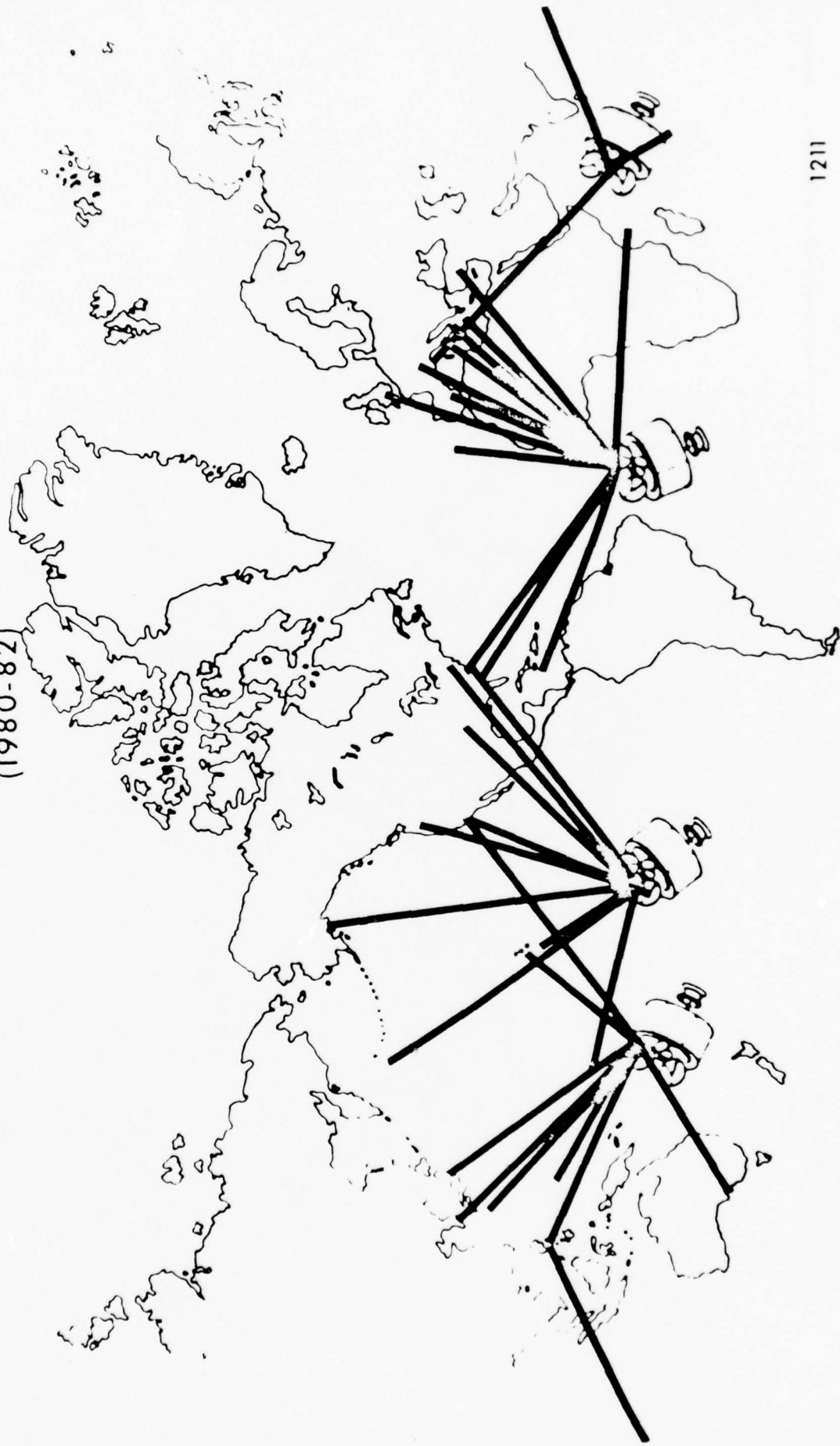
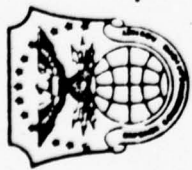

Figure 10



DEFENSE COMMUNICATIONS ENGINEERING CENTER

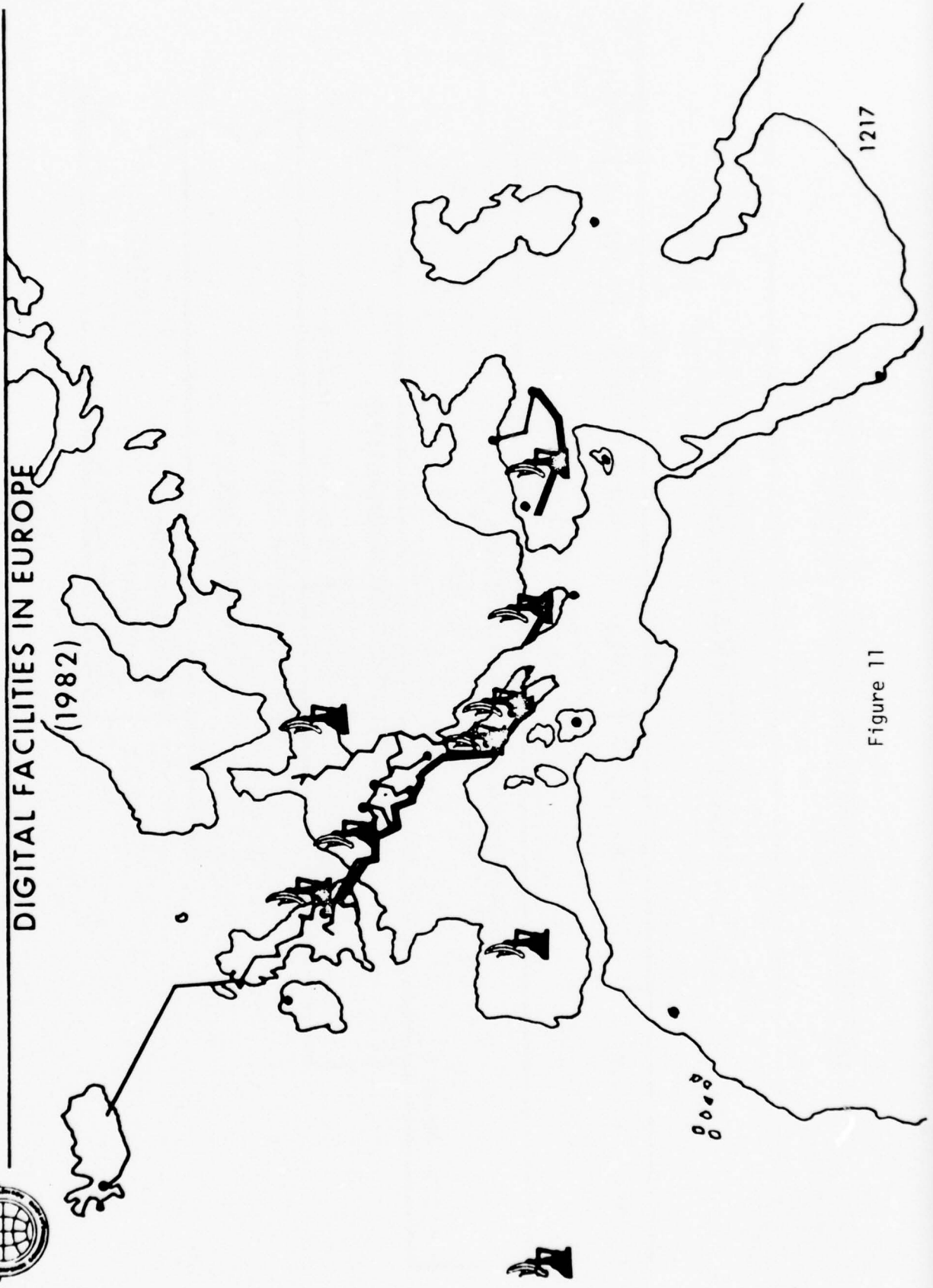

Figure 11



DEFENSE COMMUNICATIONS ENGINEERING CENTER

DCS - PLANNED TRANSITIONS

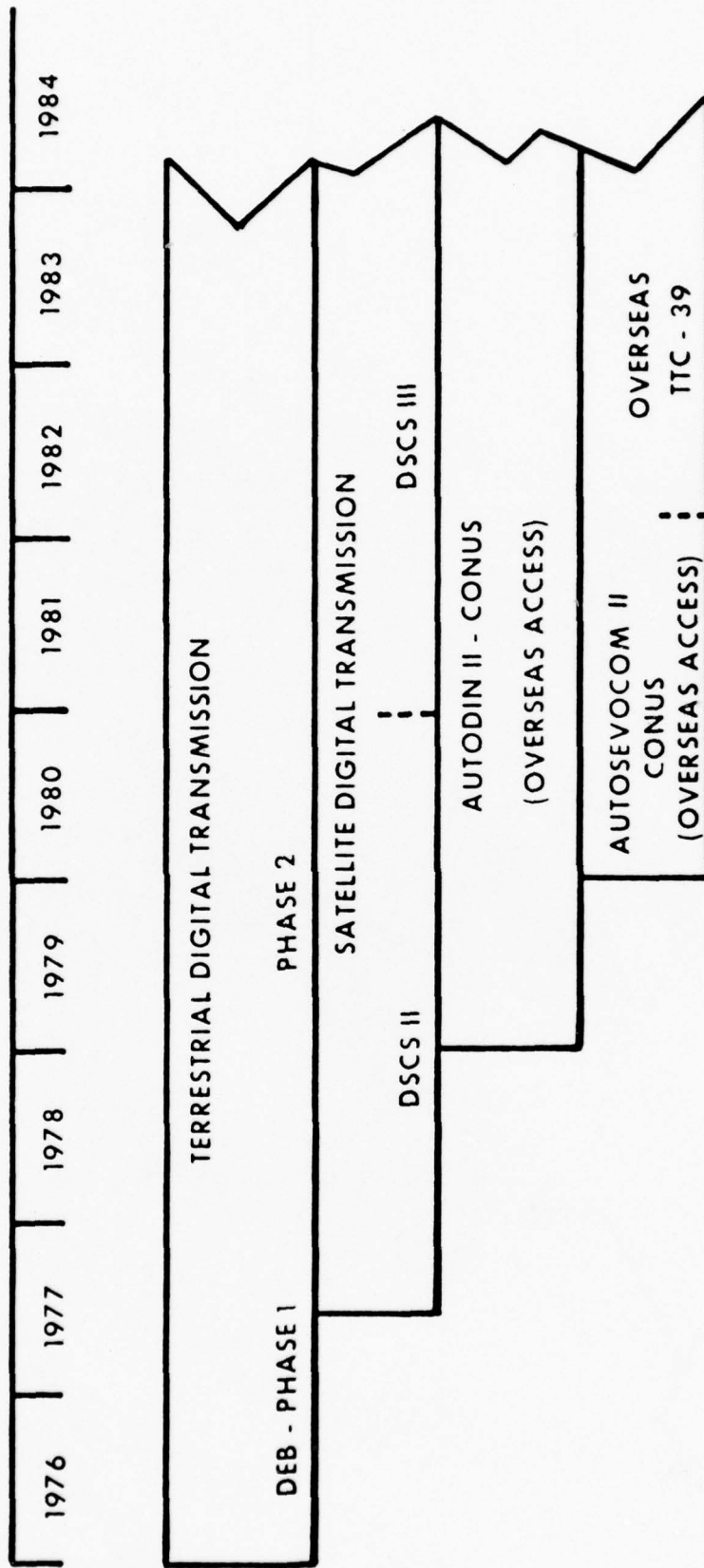

Figure 12



DEFENSE COMMUNICATIONS ENGINEERING CENTER

TRANSITIONAL ARCHITECTURE II

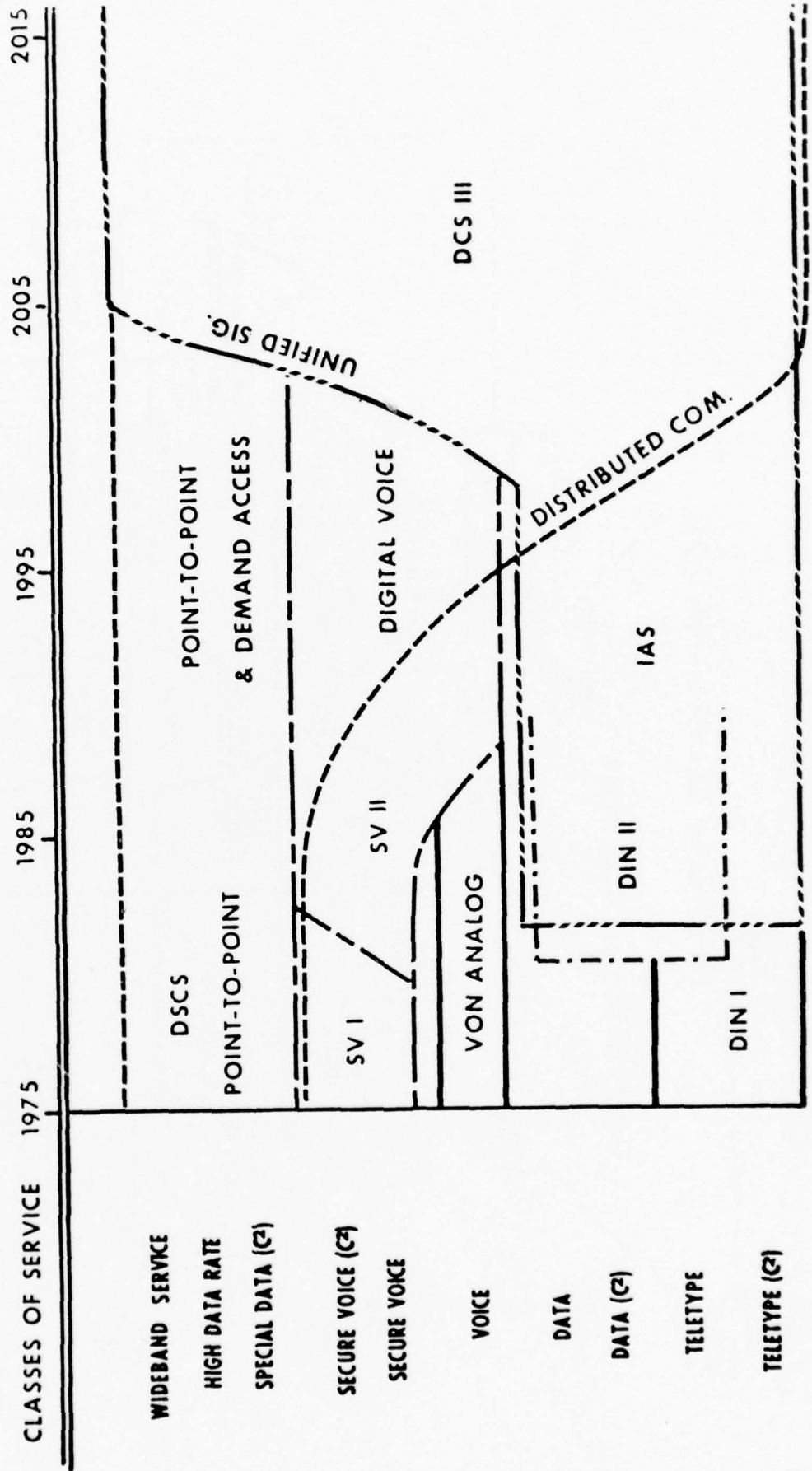
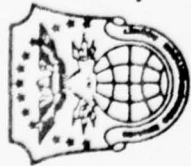
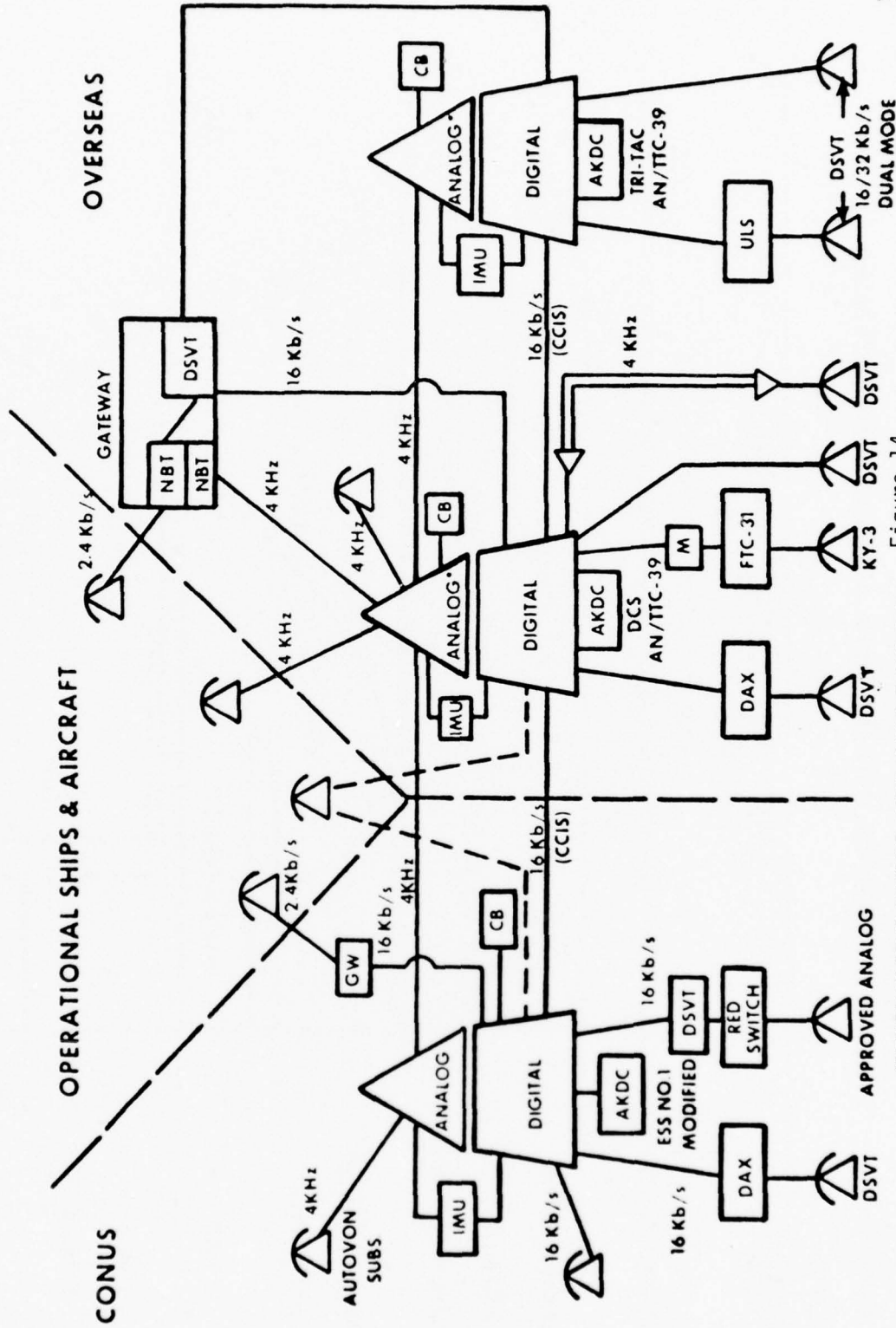

Figure 13



DEFENSE COMMUNICATIONS ENGINEERING CENTER

NETWORK CONFIGURATION



*TYPICALLY FOUR ANALOG MODULES TO ONE DIGITAL Figure 14



As Associate for Engineering Planning at the Defense Communications Agency (DCA) Defense Communications Engineering Center (DCEC) Mr. LaVean is responsible for the long range planning initiatives for the Defense Communications System (DCS). This includes the Worldwide Secure Voice Architecture (WWSVA) and the integration of the special Worldwide Military Command and Control System (WWMCCS) initiatives into the DCS. Prior to his current assignment he was Deputy Chief of the Satellite Division at DCEC. Before joining DCA seven years ago Mr. LaVean was associated with Electronics Communications, Inc. (ECI), Bendix, and the Martin Company. He has a BS degree from Michigan State University and a MS in EE from Drexel University.

G. E. LaVean
Associate Director for
Engineering Planning
Defense Communications Engineering Center
Defense Communications Agency

ACCESS AREA DIGITAL SWITCHING SYSTEM

Leo H. Wagner

US Army Communications Systems Agency
Fort Monmouth, New Jersey

Abstract

A new, modern, costeffective multi-mode telecommunications system for military posts and bases is being discussed. The system is tailored from existing and emerging commercial product lines. It is expected to provide a quantum jump in features and functions, require less space, personnel, and consumables, including power, provide savings in transmission capacity (bandwidth and bit rate), and cost less to own or lease than the existing systems with all their shortcomings.

Introduction

The Department of Defense through the Defense Communications Agency is formulating a new, modern defense communications system. The military departments and the National Security Agency are supporting DCA in that task. The Army has been assigned the responsibility to develop the access area digital switching system (AADSS) as a single telecommunications system in a geographic area that can serve all DOD subscribers in that area.

AADSS will provide the telecommunications interface between subscriber input/output devices within an access area, from one access area to adjacent access areas, to the DCS backbone system, and to other governmental, allied, and commercial networks for interface with distant subscriber input/output devices. It will be a multi-mode system that can simultaneously and in combination handle all expected I/O modes, including clear and secure voice, teletype, data, facsimile, slow scan television, and television.

A single system that can serve the command and control community, the intelligence community, the logisticians, and a host of other more and less demanding user groups is expected to result in considerable savings from sharing costly switching and transmission facilities. It is also expected to provide a quantum jump in service features and functions and at the same time be easier to maintain and to operate. The capability and cost trends in electronics clearly show that modern electronic equipment and systems can be more costeffective than their electromechanical predecessors. The micro-processor and electronic calculator fields are examples of that trend.

The new telecommunications systems cost less to acquire, are more flexible to meet changing and emerging new requirements, and need less power, less space, less personnel, and less logistics support.

The AADSS development is now entering the concept definition and validation phase. Systems alternatives have yet to be identified and tradeoff analyses performed to arrive at the best possible technical approach and a costeffective system. Using some known requirements and filling many gaps with personal conjecture, a system is postulated that can be engineered from existing and evolving commercial telecommunications equipment and could be operational in the early 1980's.

ACCESS AREA DEFINITION

An access area can generally be described as a geographic area comprising one or more post, camp, station or base entities and smaller subscriber groupings or clusters within or adjacent to the post, camp, station, or base. In consonance with DOD policy for joint telecommunications service, one access area system will serve all DOD subscribers in that geographic area. Here in New Jersey, Fort Monmouth might be considered an access area that serves the Fort Monmouth organizations, the Earle Naval Ammunition Depot, the Bayonne Military Port Facilities, the Lakehurst Naval Station, and a host of additional small user groups in this area. Fort Dix and the McGuire Air Force Base could be part of this access area, or could be an adjacent access area with direct interarea trunking. Figure 1 shows the geography. A satellite terminal could provide trunking to other access areas and to the DCS backbone system. Terrestrial trunking to one or more DCS backbone switches such as the Cedar Brook and Netcong AUTOVON switches or their successor switches would provide multiple homing to the backbone system to ensure a survivable network.

SYSTEMS REQUIREMENTS

The military telecommunications systems are in an important transition from separate special purpose systems to an integrated common user telecommunications system. The main objectives are modern service features and functions; improved flexibility, end-to-end interoperability, reliability, survivability, and security; simplicity of operation; and lower overall cost.

DCA is now postulating a transactional systems/subsystems approach, rather than a transparent approach in structuring the new DCS (1). This means that subsystems are optimized for their own requirements and different subsystems are then matched with gateway interface equipment. This is a reasonable approach which can be expected to result in considerable reductions in overall

equipment and system complexity and provide cost savings versus a transparent design where the whole subsystem has to be burdened with the complexities of interfacing subsystems.

AADSS must be able to interface with the present DCS and the Phase II DCS in the early 1980's, and transition to the Future DCS of the 1990 to 2000 time frame. The telecommunications requirements for the 1980 time frame can be projected with reasonable confidence, but not with complete certainty. One case of uncertainty is the digital voice rate which is now stated at 16 kbps, but is hoped to drop to 8, 4 or even 2 kbps using predictive coding. For 1990 and 2000 the requirements are considered speculative and will be greatly influenced by yet undeveloped technologies and unpredictable strategic situations.

In view of the expected evolution during the AADSS operating life a flexible addressing, routing, signaling, priority, preemption, and scheduling method must be employed to effectively use and share the facilities among the command and control community, the intelligence community, the logistics community, and other user groups. Shared use of the costly switching and transmission facilities will result in overall savings and will make them less susceptible to traffic peaking than several separate systems would be. Shared use includes radio and television broadcasting and cable television service. These media can provide new dimensions of service not normally considered now in the commercial area due to exclusive regulations and tariffs. In the DOD system these broadband facilities may be capable of providing most or all transmission requirements in some cases and in other cases may augment the transmission facilities during off-hours and during mobilization and other emergency situations.

The new DCS is projected to serve 1 million subscriber instruments worldwide in approximately 1500 access areas of varying size. The smallest areas will range from 50 to 300 subscriber instruments; medium areas from 300 to 2000; and large areas from 2000 to 10000. Exceptions of course are a few of the larger posts and bases, including the Pentagon which can be partitioned or otherwise specially treated.

TRAFFIC REQUIREMENTS

The I/O device traffic can be categorized into five main modes and, without looking at detailed traffic statistics, their overall impact on the systems design can be projected. Table 1 lists the modes and associated channel rates or bandwidth.

MODE	CHANNEL Rate / Bandwidth (BPS / Hz)
VOICE	16 k 2, 4, or 8 k projected
TELETYPE	45.5 to 9.6k to 16k buffered
DATA Interactive and Batch	to 16k standard rate to 1.5M high rate
FACSIMILE AND SLOW SCAN TV	to 16k standard rate to 1.5M high rate
TELEVISION	to 30M / 6M

Table 1 INPUT / OUTPUT DEVICE MODES

Voice traffic is categorized by traffic rates of 16 kbps, using continuously variable slope delta modulation, and by holding times of the order of several minutes. Transmission delays of more than one quarter of a second become disruptive to the flow of a two-way conversation and therefore must be avoided. Call set-up times of a few seconds are generally acceptable. The digital traffic volume of a single voice call can be up to 3 million bits in each direction. With data reduction, by deleting silent periods, the single voice call traffic can be reduced to approximately 1 million bits. The access network must be designed to handle approximately one simultaneous call for every ten voice subscribers. A 10,000 subscriber access area may therefore require a system with a 32 Mbps simultaneous throughput capacity without data reduction ($10,000 \times 1/10 \times 16,000 \times 2$), and 5 to 10 Mbps simultaneous throughput capacity with data reduction. Future implementation of 8, 4 or 2 kbps predictive coding will reduce the traffic volume to 1/2, 1/4, or 1/8 respectively.

Teletype traffic is categorized by approximately 10,000 bits per message page. The average message can be delayed several hours in the telecommunications system, but access area delays of not more than a few minutes are required for priority messages. This is achievable with modern character reader or other electrical character origination equipment which avoids retyping each message at the communications center. The total simultaneous access area teletype traffic volume is in the order of 1 to 3 kbps, a negligible amount when added to the voice traffic of several Mbps.

Data traffic comprises interactive messages and batch messages. The interactive messages are generally less than one thousand bits and can tolerate delays of several seconds. One interactive message origination of 1000 bits generally results in an interactive reply of 1000 bits. The total simultaneous interactive data traffic volume in an access area is in the order of 1 to 10 kbps. The batch messages are generally 100,000 to 500,000 bits in length, but can tolerate hours of delay. The total simultaneous batch traffic volume in an access area is also in the order of 1 to 10 kbps. Together, the total data traffic is equivalent to the capacity of one digital voice circuit. Future increases in data traffic can be accommodated by the system capacity being freed as the voice rates decrease to 8, 4 and 2 kbps.

The facsimile traffic is categorized by approximately 10 million to 100 million bits per message without data reduction, and 1 million to 20 million bits with data reduction. Delays of a few minutes are tolerable. Use of facsimile for the transmission of alphanumeric messages requires a tradeoff of transmission capacity versus the cost and time of retyping the information into a message, or the cost of an alphanumeric character reader, or other electrical character origination equipment, since the facsimile message requires one to five thousand times the transmission time or the transmission capacity of a teletype message. Slow scan TV requires only one third to one tenth of the transmission capacity of a facsimile message for transmitting a single frame due to the lower resolution of the TV frame. The total simultaneous facsimile and slow scan TV traffic in an access area can be 10 to 25 percent of the simultaneous voice traffic. Future increases can also be accommodated using the capacity freed due to the decreasing voice rate.

TV traffic requires 6 Megahertz per channel for analog TV and approximately 30 Megabits per second for digital TV. For a ten channel system 60 Megahertz capacity is required. Cable television systems are readily available commercially and pose no significant problem in the access area itself, but transmission between access areas may create bandwidth and transmission cost problems, especially if a number of TV channels are required.

From the above traffic categorization it can be seen that the access area system when designed for voice can also handle the teletype and data traffic without any impact on the system, other than local storage for delayed delivery, multiple delivery, and transmission rate matching. Facsimile and slow scan TV traffic requires that the voice system be oversized by approximately 10 to 25 percent, depending on the expected use of these modes. TV traffic requires such a large bandwidth that it cannot be carried over the voice network. By contrast, where a TV network is used, all of the other traffic, including voice, can be carried over the TV network with just nominal modifications to the TV network and a 10 to 25 percent increase in network capacity. This means that the AADSS must either be designed as an expanded voice network where no TV is required or as a modified TV network where all modes of traffic are required. The technology is available for either system and poses no unusual problems in the access area. However, transmission bandwidth requirements between access areas may create frequency assignment and cost problems, especially within the continental United States.

SYSTEM DESIGN

Military post and base communications designers have always relied on commercial and commercial-adapted systems and equipment to meet their telecommunications requirements. The AADSS must continue that reliance and exploit the performance growth potential inherent in the evolving commercial equipment, if a costeffective system is to be fielded. Fortunately, the telecommunications industry has already started the development and fielding of a new generation of systems and equipment that can be readily adapted to meet the AADSS requirements. This reliance on the commercial telecommunications industry product lines pays off by drastically lowering the material acquisition and life cycle costs and shortening the delivery schedules. It has the further advantage that no mobilization and contingency stocks need to be established by the Government, since the telecommunications industry can be tapped for stocks during critical times. The commercial digital systems also lend themselves readily to the incorporation of COMSEC equipment. Already today we can have a digital electronic exchange and digital subsets delivered in three months that cost one tenth and probably have 10 times the features and functions for access area switching of the AN/TTC-39. Over the next three years the commercial capabilities are expected to at least double as the latest designs on the drawing boards are being converted to product lines. The equipment cost is expected to further decrease as more "calculator" technology is being applied.

The system functions can be described in conventional terms of subscriber terminal, multiplexer/concentrator, transmission, and exchange (Figure 2), but this does not mean that each function is a separate equipment entity. These functions are interrelated and are grouped or distributed to achieve optimum system performance. Multiplexing and concentration are inherent switch functions that can be distributed throughout the area. In effect the conventional line finder functions of the electromechanical switches can now be performed within a subscriber terminal cluster and the transmission path becomes a long junctor. The next logical progression exploits the junctor capacity (bit rate) to the fullest by assigning a given subscriber terminal as much currently unused capacity as that terminal can operate with. This adaptive multiplexing trades instant unused capacity for shorter holding times and thereby provides more future traffic handling capacity. Adaptive multiplexing also makes efficient use of costly transmission facilities by eliminating the transmission of idle bit streams, especially on expensive satellite and undersea cable facilities between access areas and the DCS backbone system. Adaptive multiplexing is predicated on a flexible multimode addressing and out-of-band signaling and supervision scheme that allocates the needed bandwidth/bit rate and communications security for the specified duration at the specified time. Out-of-band signaling and supervision alleviates the inadvertent simulation of control codes by the I/O generated traffic, with or without encryption, and therefore offers the user a virtually transparent traffic channel without code restrictions. The addition of common channel signaling on multi-channel groups simplifies the common control interface by deleting duplicative steps of signal distribution and collection between the common processor and a number of parallel channels. The proposed Federal signaling system No. 6 can be adapted to provide the interface between access areas and with commercial and allied systems. The common signaling channel can be used to exchange traffic status information with these systems and between exchanges within an access area to provide certain features such as call completion after the distant I/O device becomes available (ring again), without occupying transmission capacity while waiting.

Group transmission for the non-TV modes is based on the commercial T-carrier system which provides two 1.544 Mbps group channels over two cable pairs (one channel in each direction). Several group channels can be carried over several pairs in a single cable. Where possible, T-screened cable or two separate cables are used to reduce interference between pairs operating in opposite directions and thus tolerate longer repeater spacing. For new cable installations coaxial cable will be used that can handle group and super-group channels depending on the specific requirement. The T-4 cable system for

example handles 274 Mbps over each coaxial and up to 2.74 Gbps in two 4 inch coaxial cables with 22 coaxials each (one coaxial in each direction is a spare). Where TV mode is required, a commercial interactive cable television system will be adapted to provide the transmission. One or more cable television channels are reserved for group and super-group T channels. The remaining channels are available for interactive post/base security, video training, commercial and military cable television, and all the other emerging video requirements. A thirty channel interactive cable television system is currently being test-marketed in Columbus, Ohio by Warner Cable Corp (2). A fiber optic distribution system is being tested in Chicago, Illinois by AT&T (3) and can also be considered in the future if the tests are successful. Depending on the layout of the existing cable plant, the area geography, and the clustering of the subscriber terminals, either a ring or a star distribution system will be used. Figures 3 and 4 show star and ring configurations for the main post area of Fort Monmouth. Figure 5 shows the distribution of various types of subscriber clusters for the same area and Table 2 identifies the associated densities.

DENSITY CLASS	SUBSCRIBERS per square km	SUBSCRIBERS per cluster
OFFICE COMPLEX	10,000	10
OFFICE AREA	5,000	6
SERVICE AREA	2,000	4
HIGH RESIDENTIAL	500	4
LOW RESIDENTIAL	200	2
SURBURBAN	100	2
RURAL	50	2

Table 2 SUBSCRIBER DENSITIES

Drop channels from the intraarea access hub points to the individual subscriber terminals will be tailored to the specific requirements of the terminals involved. In an office complex the drop channels terminate on a remote switching cabinet which in turn provides modern digital telephone, teletype, data, facsimile and slow scan television services, office intercommunications, word processing center access, and similar services. In housing, barracks, and training areas the drop channels provide interactive cable television which provides specific groups of channels for these user groups and includes telephone, security and fire monitoring, and similar services.

Intraarea trunking interconnects the outlying sections of the Fort Monmouth access area as shown in Figure 6. Mobile radio access is provided from a few net radio access equipments that provide coverage for the whole area. The trunks to the DCS backbone switch at Cedar Brook and Netcong will be one leased T channel each. Four additional T channels will provide local commercial access. Commercial toll access will be handled via the DCS backbone system as close as possible to the local call area of the called subscriber. Commercial cable television to the video headend is leased from a commercial cable television company. A satellite terminal provides scheduled T channel and television access to other access areas and the DCS backbone system.

Communications security is provided for one percent of the subscriber terminals and is a function of the I/O device, rather than the AADSS. Key variables are updated from the DCS backbone system. Called address and signaling information is protected by first establishing a call to a DCS distribution center followed by encrypted readdressal. Link encryption can be provided on the T channels to the DCS backbone switches. System control is performed from the DCS backbone system. Scheduled and event oriented status information is provided to the backbone system. Operation and maintenance control is retained locally. Automatic message accounting is used to supervise authorized use and to apportion system and traffic charges.

ACCOMPLISHMENTS

Comprehensive analysis of the commercial telecommunications capabilities and trends has shown that the system described above can be fielded in 1980. The main difficulty is the judicious selection of the most effective features and services that are required in a specific access area and which the users

are willing and able to pay for. The adaptability of modern switching equipment has been tested with an advanced digital electronic private automatic branch exchange, the Northern Telecom SL-1 (4). This system converts all line and trunk traffic individually to 64 kbps PCM and uses a digital bus transfer technique to switch the lines and trunks (Figure 7). The bus (equivalent to the long junctor mentioned in System Design above) can be extended over T channels to remote subscriber clusters. This relegates the terminal lines to short local drop channels. The SL-1 system uses out-of-band 2400 bps signaling and supervision to the SL-1 subscriber instrument which has 10 (expandable in increments of 10 to a total of 50) programmable keys (calculator technology) which can be assigned 22 different functions from the system control keyboard. These functions include multiline, conference, call transfer, call forward, executive override, preset dialing, and ring again. Table 3 is a typical assignment sheet for a small office or team arrangement. The users themselves can program and reprogram called numbers on keys assigned the preset dialing features named auto dial and speed call. The first has a single called number, the latter has lists of up to 10 and up to 50 called numbers. A typical 10 address speed call list is shown in Table 4.

Mr. K DCA	Mrs. L DCEC	DCEC — — — —
Office P USACC	Office S USACEEIA	Ft. Huach — — — —
COL R DAMA	Mr. H DAMO	Office DE DRCDE
	Ms. D ECOM	

Table 4 TEN ADDRESS SPEED CALL LIST

SUBSET FEATURE	ASSIGNMENTS
TYPE INSTRUMENT	SL -1, 500, 2500
KEY LAMP STRIP	1 to 5
HUNT NUMBER	Directory Number
LAST HUNT KEY	1 to 8
TRUNK GROUP ACCESS RESTRICTION	1 to 16
RING NUMBER PICKUP GROUP	1 to 128
CLASS OF SERVICE CODE	7 of 16 Codes
KEY LAMP FIELDS	10 to 50 Fields *

* Each Field May Be Assigned These Functions:

Station Number (1 to 40 Separate Numbers)
 Auto Dial (One Preset Number)
 Speed Call (1 to 10 or 1 to 50 Preset Numbers)
 Conference (Up To 30 Conferees)
 Private DCO Line
 Override
 Pri-acy Release
 Call Waiting
 Call Transfer
 Call Pickup
 Call Forwarding
 Ring Again
 Attendant Recall
 Intercom Buzz
 Intercom Voice
 Release

Table 3 SUBSET FEATURE ASSIGNMENT DATA

The interesting use of long distance abbreviated dialing should be noted in this list. Preset numbers without the last 3 or 4 digits allow speed calling to a distant office. While the call setup is in progress the remaining digits are added by the caller. For instance, the 3 digit abbreviated number used at the Defense Communications Engineering Center (DCEC) in Reston, Virginia, and the 4 digit number used at the Army Communications Command (USACC) in Fort Huachuca, Arizona. The SL-1 system was easily adapted by the manufacturer to move the A/D converter from the line circuit to the subscriber instrument which provided us a digital subset with programmable features. The SL-1 system and the SL-1 digital and analog subsets were delivered within three months of contract award and have been tested for nine months at Fort Monmouth. This test certainly proves that reliance on commercial product lines and exploiting their performance growth potential is the preferred way to provide the Department of Defense with a costeffective post/base telecommunications system, maybe it is the only way considering the current emphasis on more economical military systems.

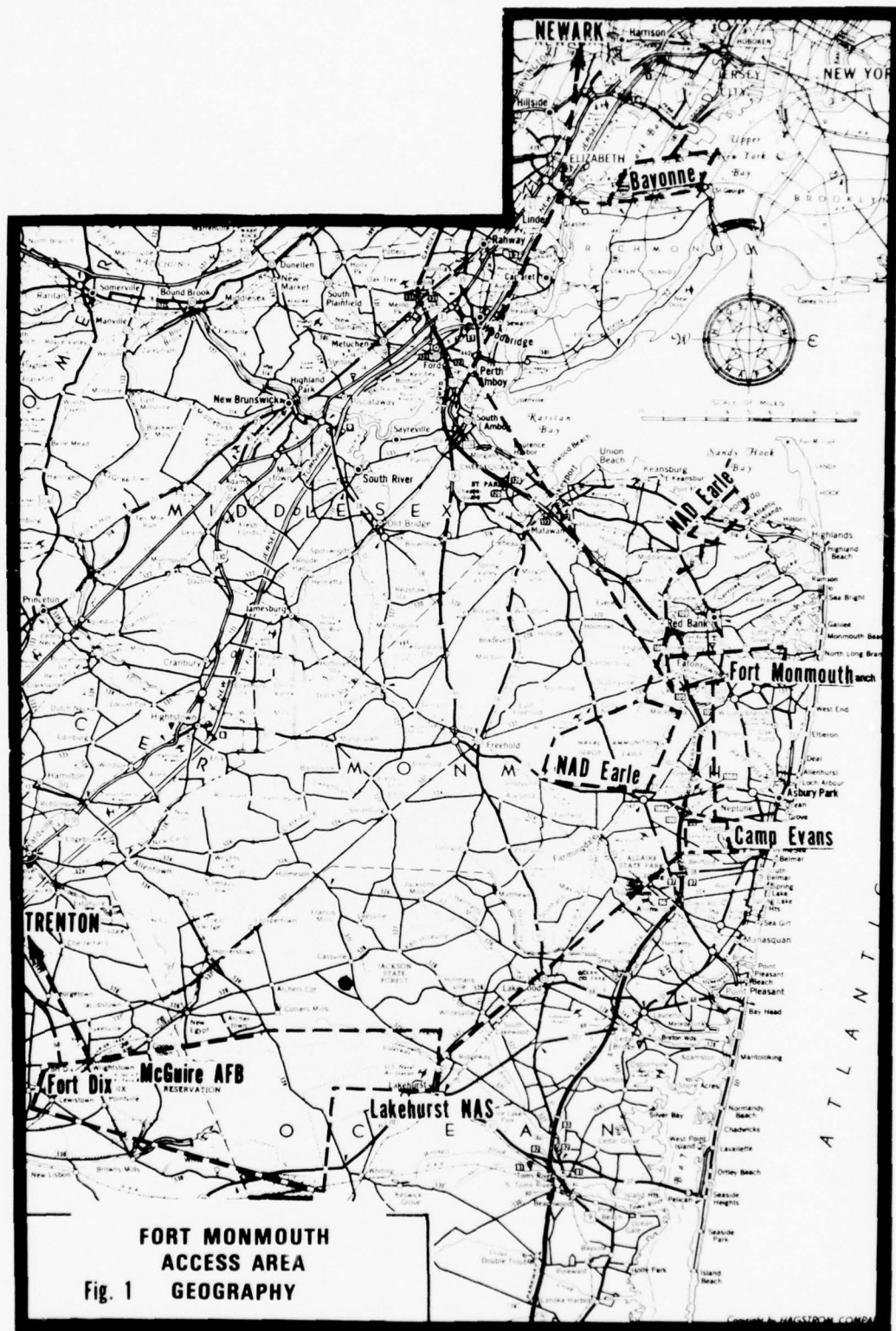

**FORT MONMOUTH
ACCESS AREA
Fig. 1 GEOGRAPHY**

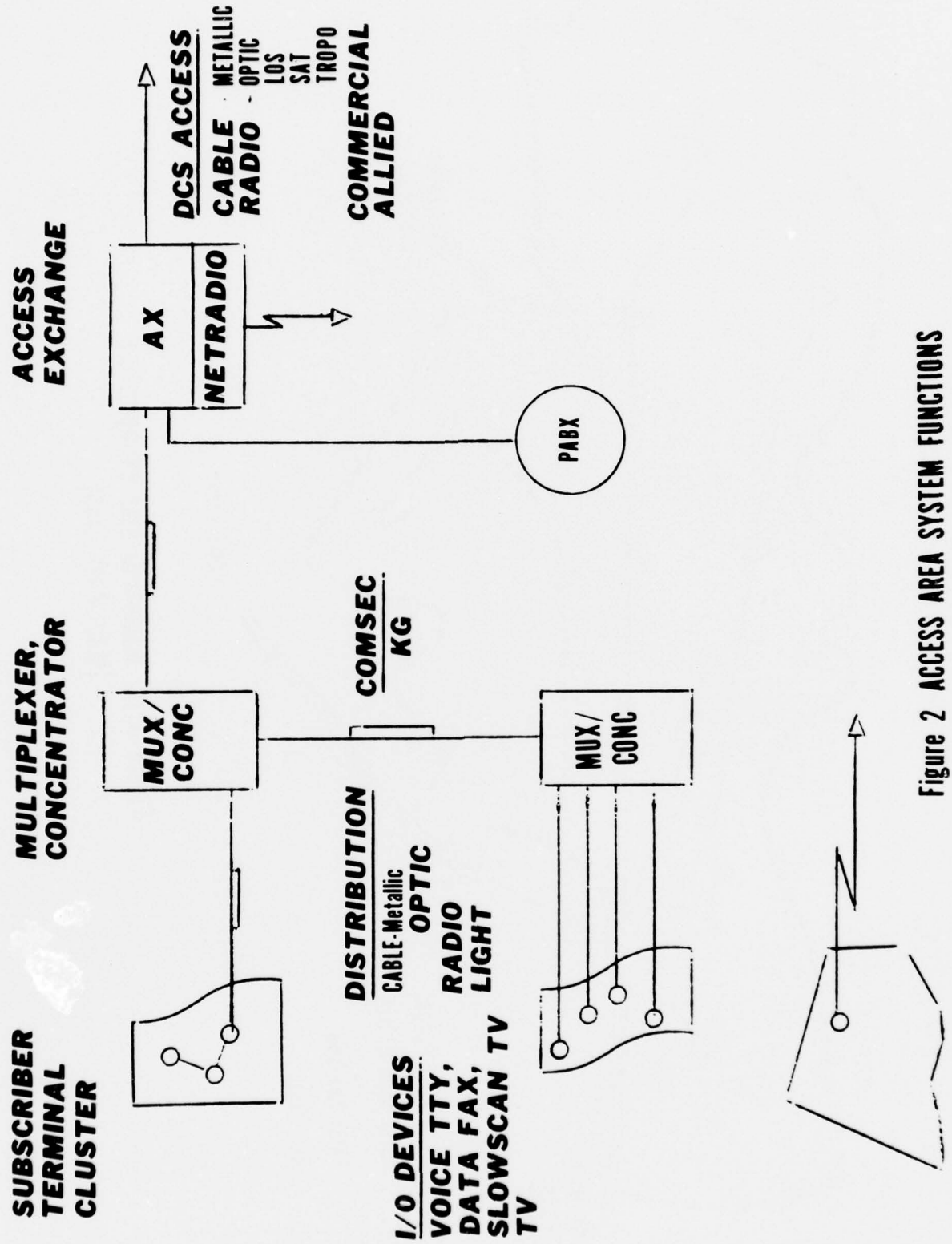

Figure 2 ACCESS AREA SYSTEM FUNCTIONS

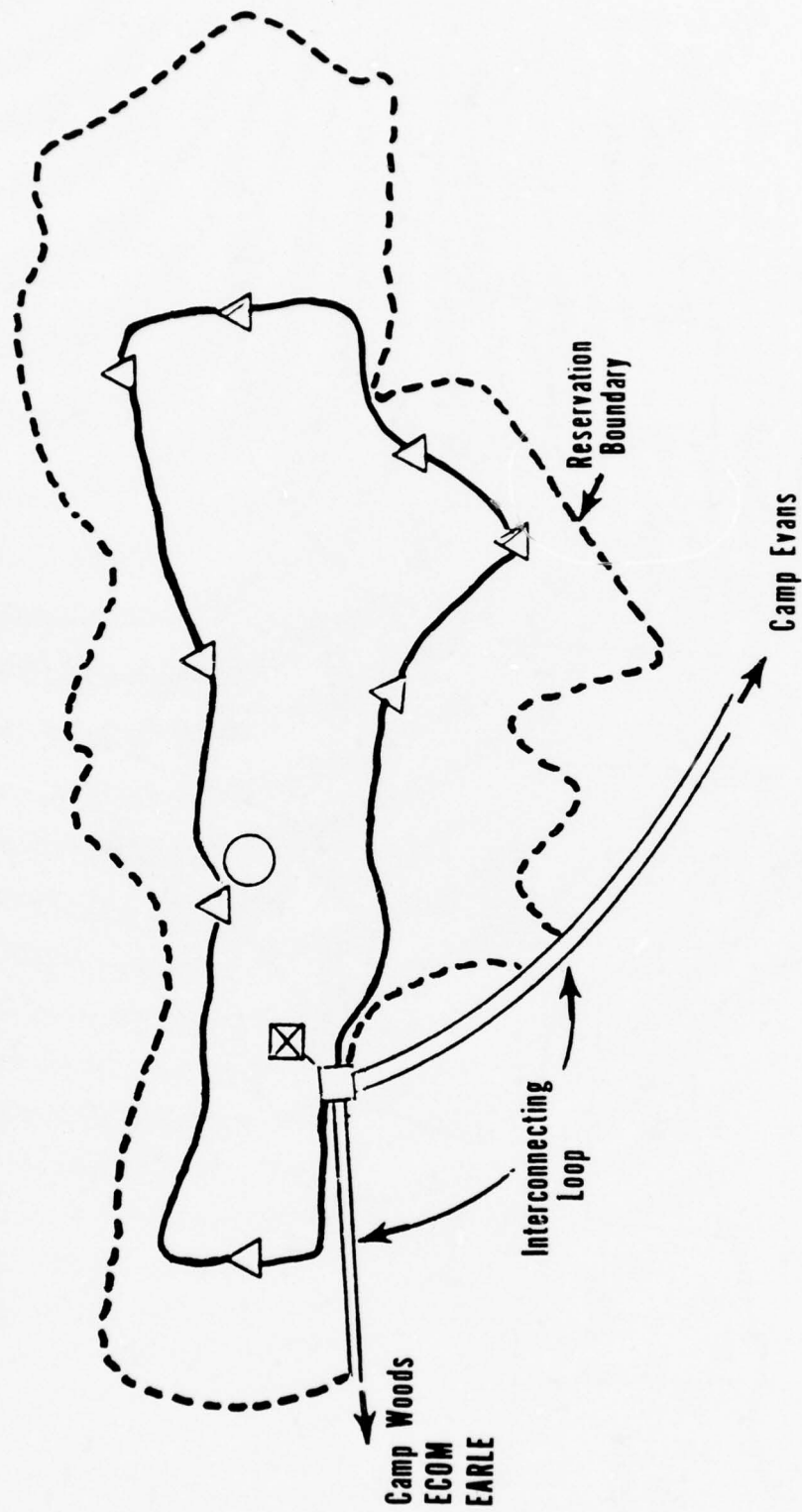

Figure 4 Ft. Monmouth ring configuration.
(Main Post Area)

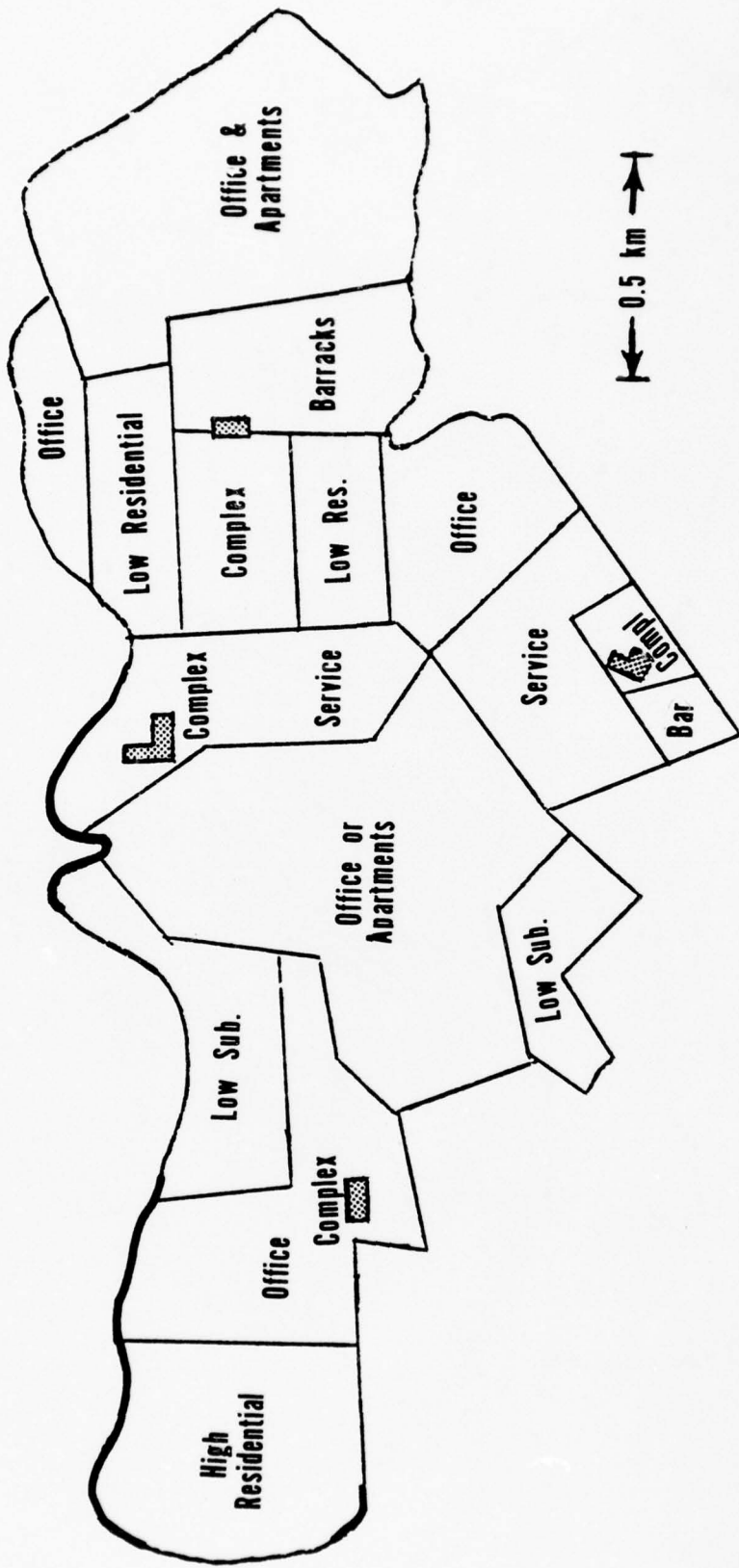

Figure 5 Density distribution for Ft. Monmouth (Main Post Area)

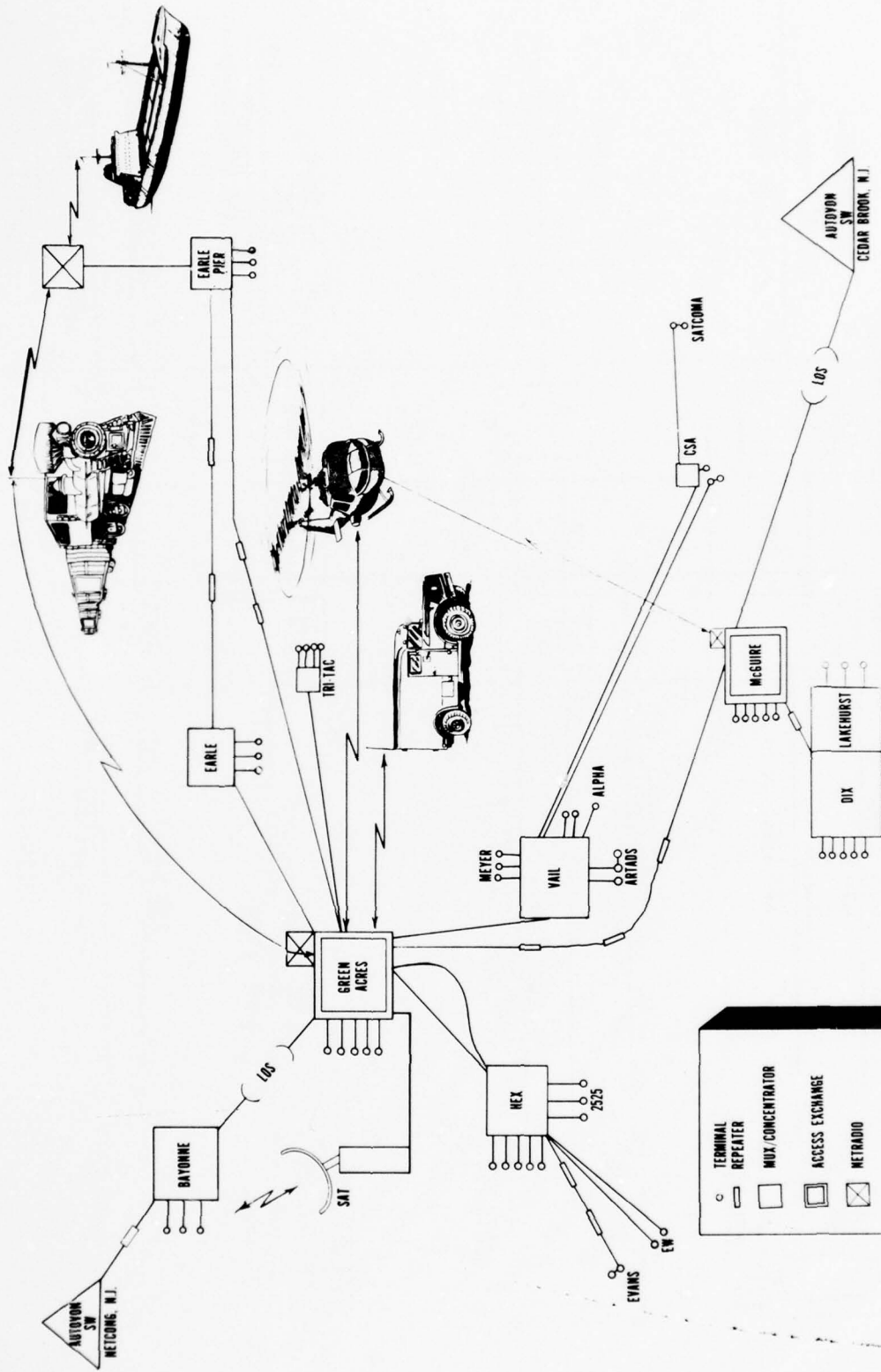

FIG. 6 FORT MONMOUTH TELECOMMUNICATIONS CONCEPT

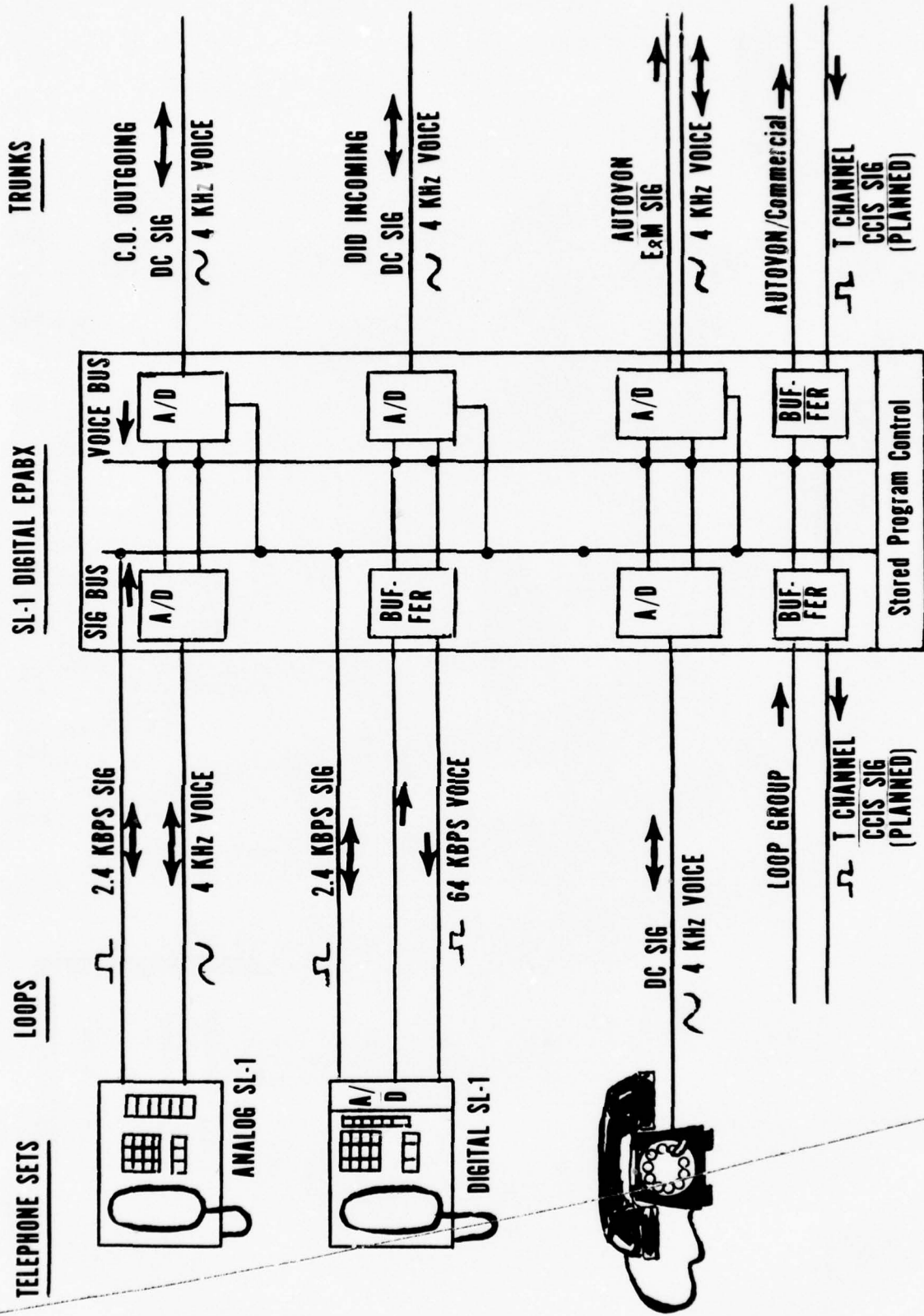

Figure 7 SL-1 Digital System

REFERENCES

1. Gino Coviello AFCEA Technical Seminar 22 June 1977 Washington, DC, Transaction v.s. Transparency: Issue for Voice/Data Switching.
2. Data Communications June 1977 p24, Back again, and now it's for real: interactive home cable tv.
3. Communications News March 1977 p26, First Lightwave Field Test Scheduled in Chicago by Bell.
4. Communications News July 1976 p24, Digital World.



BIOGRAPHY

Leo H. Wagner received a Diplom Engineer degree (MSEE) from the Technical University of Munich, Germany in 1957 and did post-graduate work in business administration at the Technical Universities of Munich and Berlin.

Since 1958 he has been with the US Army as an electronics engineer contributing to the development of various telecommunications equipment and systems, including Tactical Switches, Automatic Message Processing System AMPS, Unified Communications System UNICOM, and the combined US-UK-CAN-AUS Tactical Communications System MALLARD. For the last eight years in the Project Management Office DCS (ARMY) Communications Systems he has been instrumental in the development of optical character readers, facsimile machines, multiplexers, switches, cable and radio transmission equipment, automated test and measurement equipment, and base communications systems for the Army Communications Command and the Defense Communications Agency.

Mr. Wagner holds several patents including one for digital conferencing, and has published a number of technical papers. He is a Senior Member of the Institute of Electrical and Electronics Engineers and a civilian graduate of the Armed Forces Staff College.

AUTODIN II INTERFACE

W. S. Mc Clary
Computer Sciences Corporation
Falls Church, Virginia 22042

INTRODUCTION

The AUTODIN II is being designed to attract subscribers primarily from the interactive, query-response, and bulk file transfer communities. At the same time the service presently provided to the narrative traffic subscriber must be maintained. Therefore, it was decided to implement a packet-switched service to provide the low delay for the fast response traffic and to provide high speed trunking to the present AUTODIN subscribers.

A major design goal is to minimize the impact of AUTODIN use on the user. A desire is, of course, to require no changes in either the operation or procedures which are presently in use by potential subscribers. While this desire is essentially impossible, the interface requirements are a combination of recognized electrical and logical standards plus an absolutely minimum amount of information from users over and above the text (or data) to be transferred by the network. This paper attempts to outline these requirements as they are known at this stage of the design in order to facilitate planning at the general level for users desiring to make use of the AUTODIN.

INTERFACE METHODS

In order to understand the AUTODIN II, a diagram is presented as Figure 1. This diagram shows the salient features of a network node with the various methods for network connection. The means of network connection may be categorized into three fundamental ways:

1. User-provided front end processors programmed by the user to satisfy the protocol requirements of the network. The specifications for the protocol will be published by DCA as a by-product of the network development so that the user may program the front end in either a HOL or native language according to the user's dictates. At a minimum, the Segment Interface Protocol (SIP) must be implemented in order to present the network all of the mandatory information for addressing, security protection, error control, and category of service (precedence) desired from the network. In addition, if the user wishes to converse with other AUTODIN II users who subscribe to the standard Transmission Control Protocol (TCP), he must implement this protocol. However, it is not network mandatory if the user has developed a transmission control protocol within his own closed community.

2. Network provided control units (Single Channel or Multichannel Control Units (SCCU, MCCU)). These devices, based on minicomputer implementation, allow a user to attach a host to the network and, according to the specific interface options selected by the user, "manages" the desired connections through the network by providing the host interface (Host Specific Interface) and the previously mentioned TCP and SIP. This device will be provided to authorized users by DCA on a tariffed basis. This device is the keystone to the desire not to impact the user when connecting to the network and contains all of the protocol handlers and accountability packages for the network to provide the service desired by the user.

3. Terminal access arrangements. Terminals may directly interface the network in one of three basic ways; directly connected to the node via an access line to the Terminal Access Controller (TAC), interfacing through a time division multiplexer located for geographical cost savings within the network architecture, or via an Interface Control Unit (ICU) which, in turn, interfaces the TAC and provides rudimentary control for half duplex terminals.

Each of these devices are described in detail in DCA publications and these details are not covered in this general discussion. It is considered sufficient to say that individual cases must be coordinated with DCA prior to inclusion within AUTODIN and the particular method will be determined during this coordination. The purpose of this paper is to indicate the information requirements from a general user in order that the network may transport information for the users.

USER MODES

To the general user there are three modes of interface to AUTODIN II; Mode IIA, which is a character interface, Mode VI which is a binary interface, and Mode I, which is basically designed to handle current AUTODIN I subscribers directly interfaced to AUTODIN II nodes. Of these modes, the ones specifically addressed in this paper is the Mode IIA and Mode VI. This is not intended to ignore the third, but in the early time frame of AUTODIN II, the previous two categories are the most probable users and are considered the most important to the readers at this time. Of these two, the detailed discussion will concentrate on the IIA which will be the method by which a character oriented subscriber will interface with the network.

Mode IIA

This mode will be used by a subscriber with a character-oriented terminal which may be epitomized by a keyboard device such as a Model 35 Teletypewriter. Transmission is effected by a serial character-by-character stream in a variety of signalling codes; the specific code being irrelevant to this discussion. Recognize that the particular input device (e.g., paper tape reader, keyboard, cassette, etc.) is of no concern; only that the transmission is serial by character in a recognizable and accepted code set.

Figure 2 indicates the information required as a minimum by the network to establish a communication path through the network. The terminal operator would type (or punch) a SOH character followed by a selected command code and an EOL character immediately prior to the text of the transmission. The transmission would then be bounded by the ETX character. The network access area (in this case the TAC) would have previously been loaded with a "canned" leader which would be selected for the access line upon receipt of the command code. This leader would then contain all of the information required to route the transmission to a destination contained in the "canned"

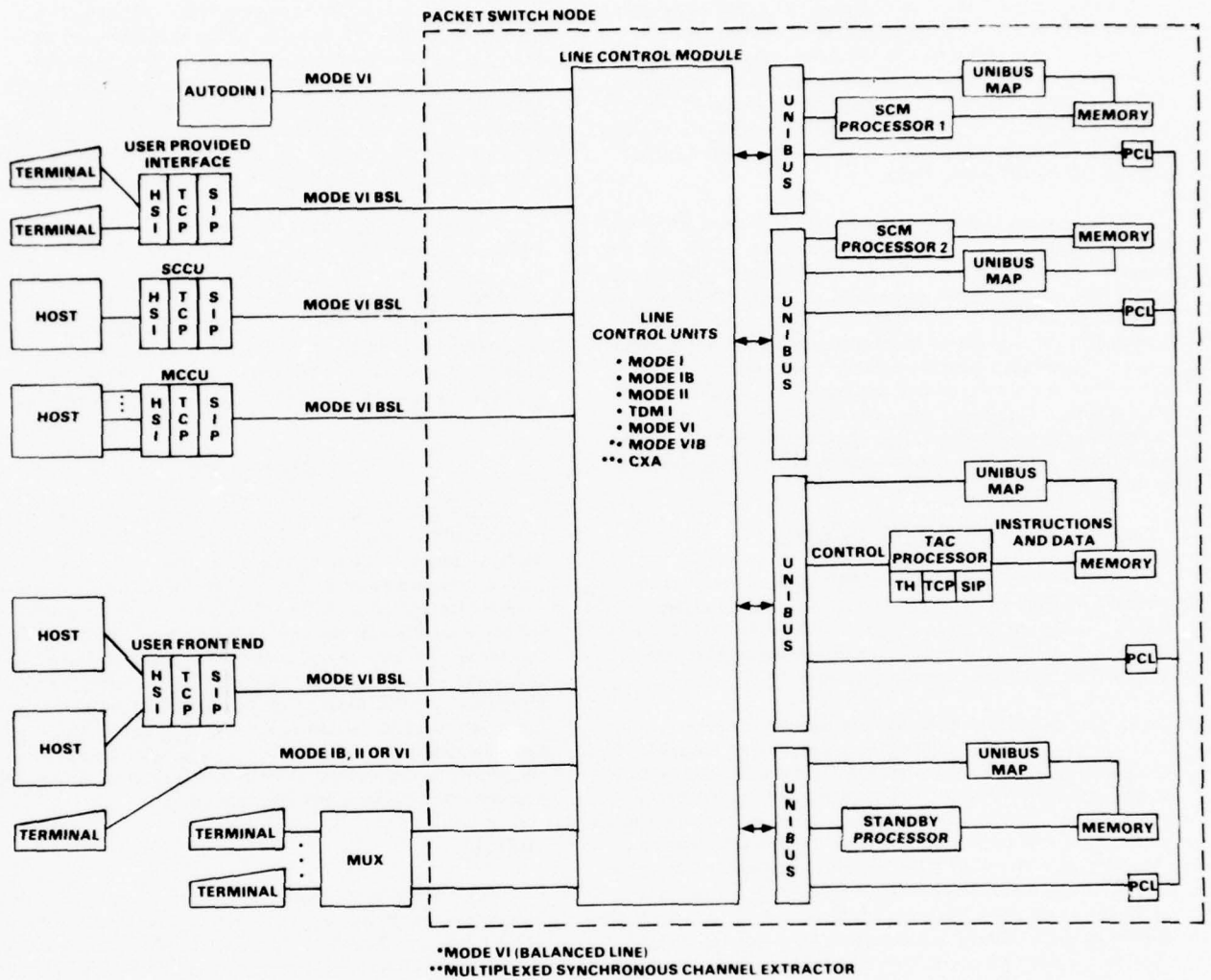
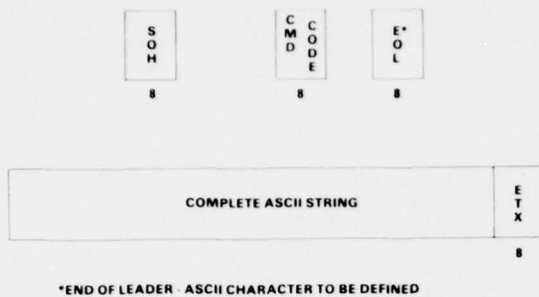

Figure 1. AUTODIN II Connection Diagram



*END OF LEADER - ASCII CHARACTER TO BE DEFINED

Figure 2. Character Canned Segment Leader, Type J - Mode IIA

leader at a predetermined precedence and unclassified security level. Further, a preselected TCC would be inserted to identify the community of interest associated with the source-destination pair. Note that while this is the minimum amount of information required for connection establishment, it also presents the least flexibility of network connection to the user; one predetermined destination, TCC, and precedence, and unclassified security level.

The next level of sophistication is illustrated in Figure 3. This differs in that the user may identify the destination and precedence of each connection but is still restricted to an unclassified security level and a single community of interest. However, it should be noted that there is a requirement for only six data items (10 characters) in addition to the text.

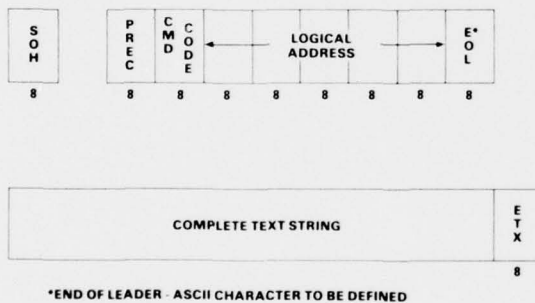

*END OF LEADER - ASCII CHARACTER TO BE DEFINED

Figure 3. Character Unclassified Segment Leader, Type K - Mode IIA

Finally, there is the complete capability offered to the Mode IIA user. This is illustrated in Figure 4. This allows the user to specify all fields upon connection establishment. Again, the total requirement is for eight data items (15 characters).

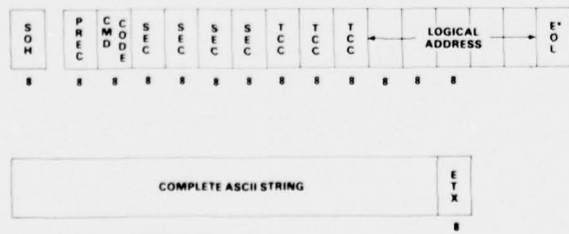

*END OF LEADER CHARACTER

Figure 4. Character Segment Leader, Type I - Mode IIA

(As an aside, there is presently an investigation pertaining to probability of misdelivery that indicates the desirability of a redundant address and TCC field which would add another eight characters to the requirement. Final design will probably contain this redundant field.

There are two points which should be highlighted here. The above description of required information is in addition to any required format information that is required by the user community. For example, if the community required a formal format (or procedure) such as JANAP-128, or similar, this information is carried as text in the AUTODIN II network and no level of control or procedure in the network makes use of the information in the text field. Secondly, what ever segmentation occurs to the text in the network for transmission purposes (packetizing), the information discussed above is provided only once at connection establishment and applies for as long as the connection exists.

Mode VI

Mode VI exists primarily for intelligent devices which are capable of segmenting traffic on a connection into approximately 4700 bits or less. Further, it is required that a 32 bit cyclic redundancy code be generated for each segment and the Advanced Data Communications Control Procedure (ADCCP) flag sequence and header be constructed. This format assumes a programmable (or logical circuit equivalent) device such as a Channel Control Unit (SCCU, MCCU), Front-End Processor, or host main frame.

The illustrative figures (Figures 5-7) are included for reference. The field uses are similar to the formats described in Mode IIA.

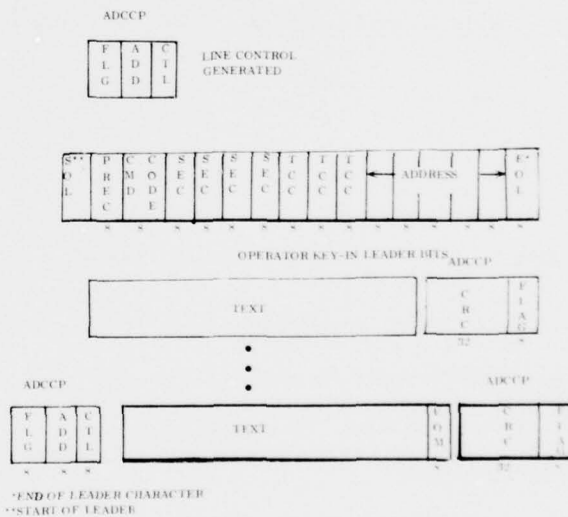

Figure 5. Type C - Character Segment Leader/Mode VI

true.

Complete specifications of the logical and physical (electrical and mechanical) interface will be published as a product of the design and implementation and will be available as a publication from DCA to affected parties.

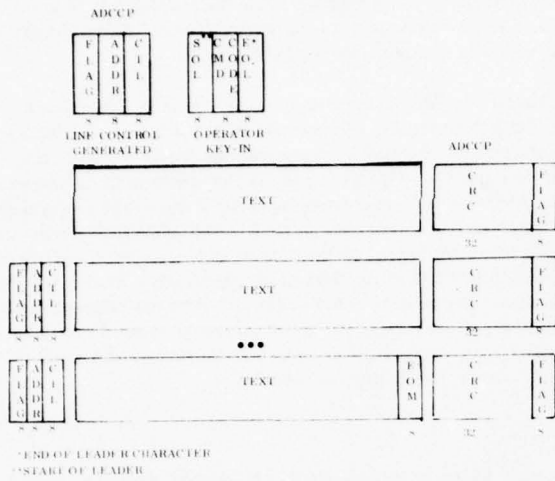

Figure 6. Type D - Character Canned Segment Leader/Mode VI

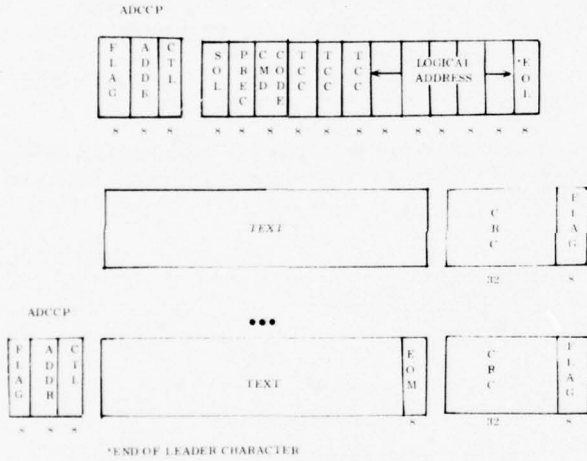

Figure 7. Type E - Character Unclassified Segment Leader/Move VI

SUMMATION

An attempt has been made to illustrate on a general level the information required by AUTODIN II to establish a connection between two users. The particular data items desired from subscribers requiring three levels of flexibility have been presented.

While any packet switching network with multiple levels of independent protocol exhibits a formidable level of internal network design details, the ultimate results as viewed by a single user need not be overly complicated. The design principles in the AUTODIN II are simplicity to the user with a resultant minimum impact on user procedures, programs, and equipment. As the design effort continues toward an initial implementation in 1979, some details of the formats may occur. However, it is anticipated that the changes will be minimal and that this description will remain essentially



Mr. McClary has been employed by CSC since 1973. During this time he has been associated with a number of communications design activities for clients including the Canadian Department of National Defense, U. S. Air Force, Defense Communications Agency, U. S. Army Communications Command, and the Federal Aviation Agency. These systems have all involved networks handling digital information using computers as the primary network resource. Prior to his association with CSC, he has been employed with Bell Aerosystems, Telcom Inc., Auerbach, and URS Corp. in a number of communications assignments. Mr. McClary is presently assigned as a senior member of the AUTODIN II staff in areas of system engineering.

DIGITAL MODEM TECHNOLOGY
FOR STRATEGIC AND TACTICAL TROPOSCATTER APPLICATIONS

Walter J. Cybrowski
Communications/ADP Laboratory
USAECOM, Fort Monmouth, NJ 07703

Abstract

The Adaptive Decision Feedback Equalizer, the Distortion Adaptive Receiver and the Combined Coding and Modulation modems are the most advanced modulation/demodulation techniques for transmission of digital information over strategic and tactical troposcatter links. The theory of operation for each of these modulation/demodulation techniques are described. Over-the-air test results for each are presented.

Introduction

Recent interest in multimegabit digital troposcatter communications has prompted the development of several advanced modulation/demodulation techniques. The digital modems offer improved voice and data channel quality for long haul strategic systems and improved link reliability for tactical systems.

The two most advanced techniques are the Adaptive Decision Feedback Equalizer (ADFE) and the Distortion Adaptive Receiver (DAR). Each of these two techniques were developed to provide up to quadruple diversity operation. They have undergone extensive testing over both simulated links and operational L and C Band tropo links in the U.S. and Europe.

A combination coding and modulation technique has also been developed in a non-diversity configuration. Testing over simulated link and limited over-the-air testing at RADC has been accomplished on this modem.

These new modem techniques have a performance advantage over previous troposcatter digital modems in that performance is enhanced by utilizing available in-band frequency diversity.

The troposcatter channel presents special problems to the modem designer. The Rayleigh distributed fading and time dispersive characteristics of the tropo channel cause various degrees of signal distortion and intersymbol interference. The advanced modems discussed herein have been successful in minimizing intersymbol interference and gaining additional diversity performance.

Discussion

Media Effects

The troposcatter channel is characterized by short term received signal level fading at a nominal 0.25 to 10 Hz rate with 15-25 dB fade depths. Long term yearly variations in received signal average 10-20 dB. RMS multipath

delays of 50 ns, for short paths, and up to approximately 500 ns, for long strategic paths, are common. To achieve reliable communications, explicit diversity techniques are employed. Dual space diversity is commonly used on tactical and short strategic links. Combinations of space and frequency diversity are employed to obtain quadruple diversity normally used for longer strategic links.

Severe multipath conditions cause intermodulation distortion and cross-talk in present FDM/FM analog systems. Digital systems suffer intersymbol interference leading to an irreducible error rate floor. The new modems eliminate intersymbol interference, within certain limits, and utilize the frequency selective fading over the transmitted signal bandwidth to achieve added in-band diversity.

An estimate of the multipath delay for a particular path can be found by a method proposed by Bello⁽¹⁾. The geometry and antenna beam width of the path are used to calculate the RMS multipath spread (2σ) defined as the two-sided standard deviation of the delay variable $q(t)$. The 2σ value of multipath delay may be a significant part of or greater than the transmitted data symbol width, (T) resulting in intersymbol interference. The received data symbol energy is spread out in time at the receiver and some of this energy overlaps the following received pulse causing errors. This effect can be visualized as being caused by many independent scattering paths which are uncorrelated.

During frequency selective fading conditions a segment of the transmitted signal spectrum fades a significant amount as compared to the remainder of the spectrum. If these uncorrelated energy differences could be detected, an in-band frequency diversity performance improvement could be realized. Gaining implicit diversity requires the identification of the signal components received from different delay paths and utilizing these in the decision process⁽²⁾. The amount of implicit diversity (D_i) to be gained is proportional to the multipath spread (2σ), and (W) the signal bandwidth, $D_i = 2\sigma W$. Thus the greater the transmitted signal bandwidth or multipath spread, the greater the achievable implicit diversity advantage. Since transmitted signal bandwidth is normally restricted to 3.5, 7 or 10.5 MHz for the 99% power bandwidth, the amount of link multipath available will influence modem performance. The effect of increased implicit diversity on system performance will be to reduce the probability of experiencing a fade below a threshold error probability. Additionally the duration of fades below the threshold that do occur will also be reduced.⁽³⁾

An upper bound exists on the amount of multipath a modem can tolerate before intersymbol interference occurs. This is normally expressed in terms of $2\sigma/T$ the ratio of delay power spectra, multipath, to the symbol interval T.

Figure 1 shows the effects of multipath on the performance of an Adaptive Diversity Feedback Equalizer (ADFE) modem.⁽³⁾ Average Bit Error Rate (BER) is plotted versus $2\sigma/T$ with the modem operating at 9.4 mb/s, in a simulated quad diversity configuration. The performance increases as $2\sigma/T$ approaches unity and then decreases as dominant intersymbol interference causes demodulation errors. Note that for constant receive signal level of $E_b/N_0 = 11$ and 12 dB, BER performance increases by an order of magnitude with an increase in multipath from 0.1 to unity.

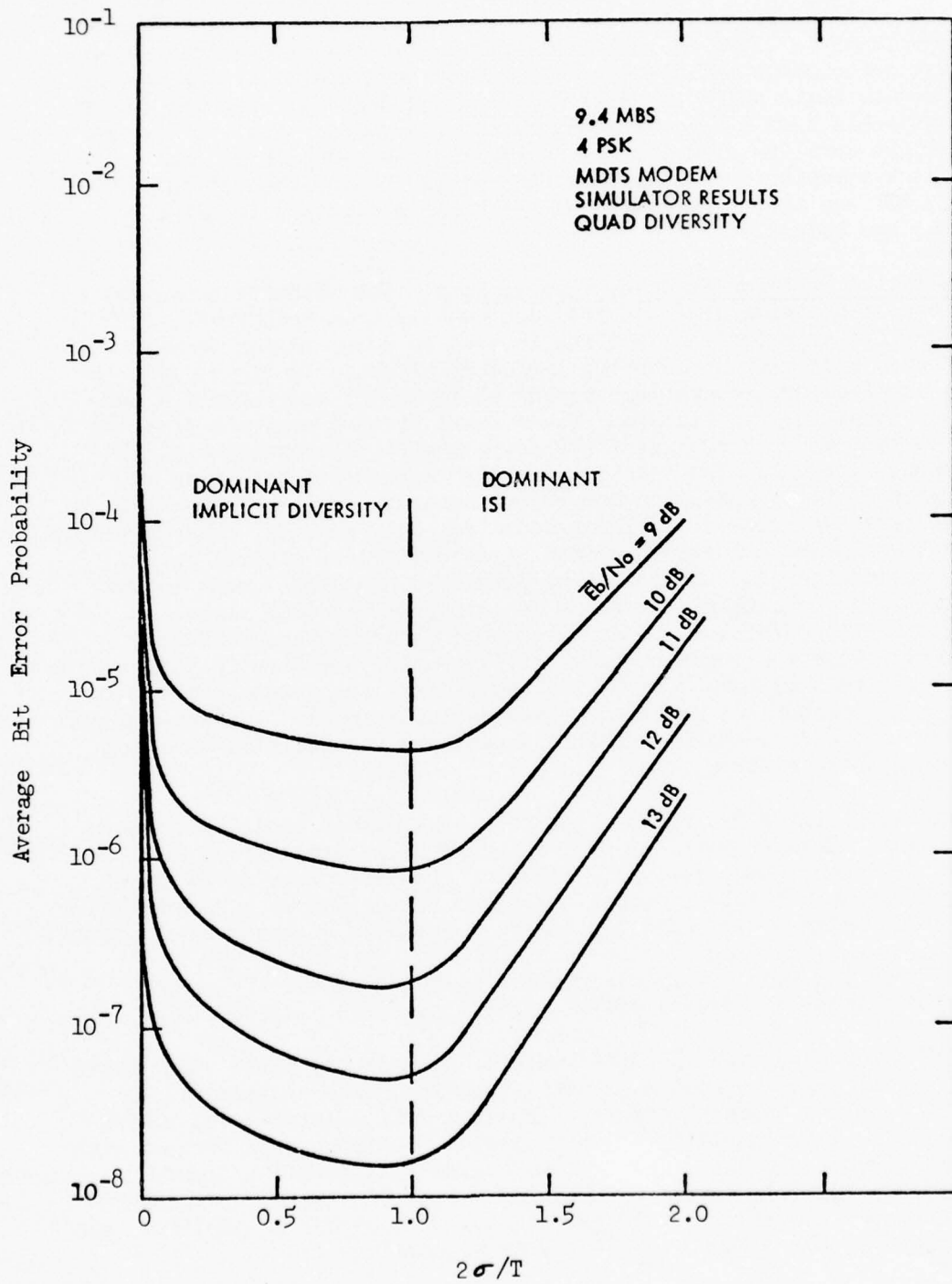

Figure 1 ADFE Modem Implicit Diversity Effects

Digital Modems

Due to the large path losses associated with troposcatter communications, effective use of the transmitter power output stage must be made. This stage is typically a klystron amplifier operated in the saturation region for optimum prime power efficiency. A constant envelope modulation signal is preferred to avoid AM/PM and AM/AM effects. A high data packing factor is also desirable from a spectrum utilization viewpoint. The requirement for a constant envelope signal leads to FSK and PSK modulation. PSK utilizes less occupied bandwidth than FSK and has better theoretical performance. PSK was therefore chosen as the basic modulation format for each of the new modems.

a. Adaptive Decision Feedback Equalization: The adaptive equalization approach uses a decision directed feedback equalization technique. A tapped delay line with feedback control is used to adapt to the varying media effects, multipath and doppler frequency offset. In Figure 2(3) the diversity receiver down-converter outputs at IF 70 MHz are amplified and fed to individual forward filters. The forward filter consists of 3 tap acoustic surface wave delay line (SAW) devices with tap spacings of one-half a symbol interval. The function of this transversal filter is to provide matched filter reception and reduce intersymbol interference due to future received, but not yet decision detected, data symbols. The diversity equalized signals are coherently summed by an equivalent maximal ratio predetection combiner and the resulting single 70 MHz signal sent to the demodulator. The demodulator performs detection of the QPSK signal, filtering and A/D conversion. I and Q channel data are then converted into data decisions and error signals. Differential decoding is performed and an error signal is formed by taking the difference between the output of a finite integrator and a predetermined decision level. The error signal is supplied to the forward and backward equalizers for decision-directed adaptation of these filters.

The backward filter has up to three taps, the number used depending on link multipath. This transversal filter is digitally implemented with tap spacing at the symbol interval. The function of this filter is to cancel past digit intersymbol interference. Backward filter tap weights are formed by correlating delayed data with the baseband decision directed error signal.

A time tracking loop determines receive timing from the ADFE error signal and continually corrects offsets in transmit and receive timing.

The modulator used with the ADFE modem is a quadruple phase shift keyed (QPSK) modulator shown in Figure 3. The video interface provides level matching between the balanced inputs. Transmit data multiplex and timing circuit provides the capability of multiplexing two input data streams with the 64 Kb/s service channel. The QPSK modulator is a straight forward modulator. The 70 MHz spectrum control and driver limits the occupied 99% power spectrum of the modulated 70 MHz signal. The signal is amplified and divided providing two outputs for diversity transmitters.

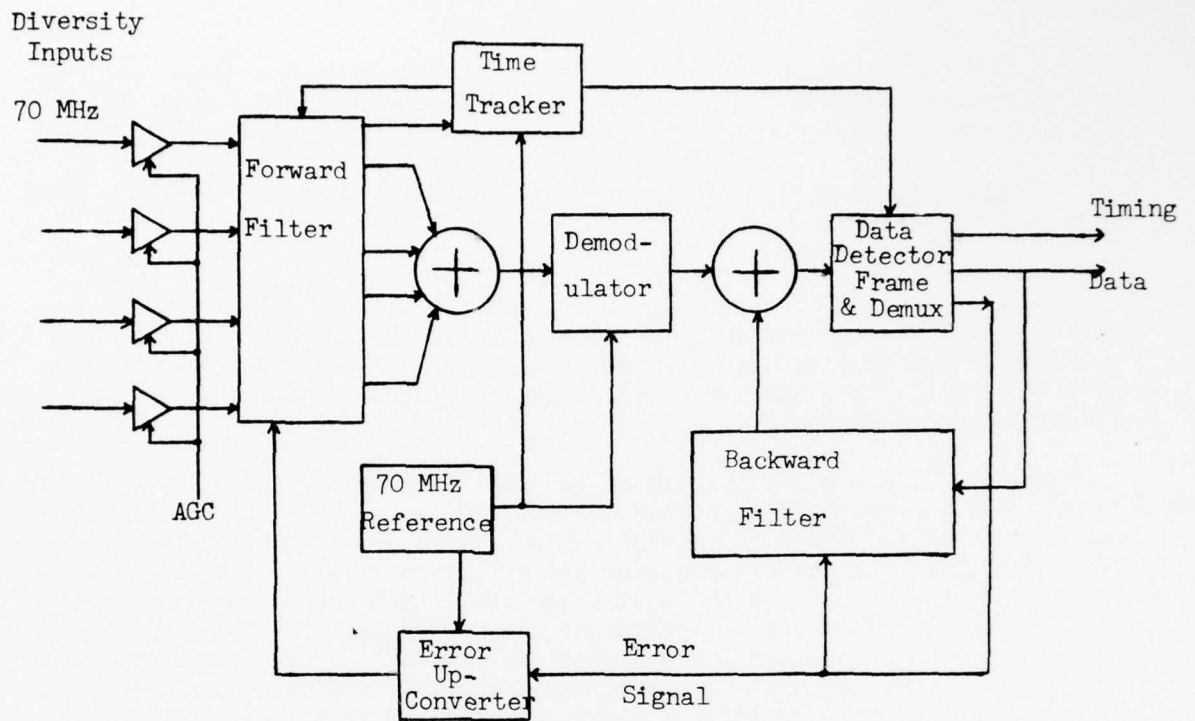

Figure 2 ADFE Demodulator

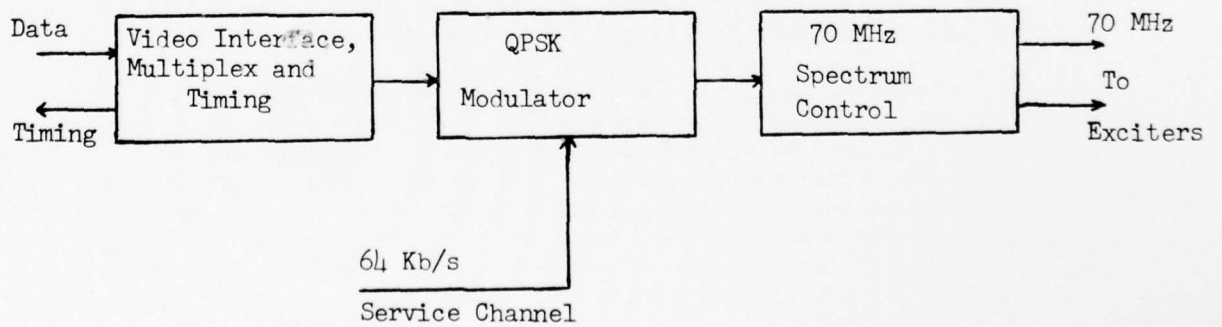

Figure 3 ADFE Modulator

Performance results for over the air testing at 12.6 Mb/s and 6.3 Mb/s are shown in Figures 4 and 5⁽³⁾ respectively.

The ADFE modem, known as the Megabit Digital Troposcatter Subsystem (MDTS) nomenclatured MD-918/GRC, was developed under the program management of USACSA and technical direction of USAECOM under Contract DAAB07-74-C-0040.

b. Distortion Adaptive Receiver: The Distortion Adaptive Receiver (DAR) utilizes transmitter time gating of the modulated carrier to avoid inter-symbol interference caused by multipath. In Figure 6⁽⁴⁾ a 70 MHz intermediate carrier is PSK modulated by the information bits. The modulated IF carrier is then time gated to have an approximate 50% off period. The off period forms a guard time so that the multipath distorted pulses, do not overlap. A matched filter receiver implementation makes use of all the energy in the symbol interval. Thus the DAR gains an implicit diversity advantage due to in-band frequency diversity.

Figure 7⁽⁴⁾ is a block diagram of the DAR receiver for simplicity, a binary PSK implementation is shown instead of the actual QPSK. A matched filter receiver is formed by multiplying the distorted received signal by a reference signal and integrating over the symbol interval. The reference signal is formed by using a recirculating loop with a gain of approximately 0.9. All received symbols of 180° phase are converted to 0° phase in the loop. The delay line causes several past pulses to be stored forming a memory of the tropo channel. Signals add coherently and noise adds incoherently in the loop yielding a processing gain of 13 dB for $K = 0.9$. A nearly noise free reference is established.

In a quadrature diversity system an individual adaptive matched filter is used for each diversity channel. The outputs of each channel are added and the reference signal is multiplied with the sum. This combining is pre-detection due to the linear nature of the detection process. It is equivalent to maximal ratio pre-detection combining.

The above description assumed the time gate was sufficiently wide to act as a guard band to prevent intersymbol interference. As the data rate is increased or media multipath increases the time gate will no longer be wide enough and an irreducible error rate is reached.

Receive pulses will overlap, causing intersymbol interference, and the bit decisions will be increasing incorrectly. By adding a Decision Feedback Equalizer (DFE) to the DAR modem the intersymbol interference can be adaptively removed. Referring to Figure 8 an error signal is formed and will be non-zero whenever intersymbol interference occurs. The error signal is multiplied by the past received bit, inverted, and added to the output of the integrate and dump filter to cancel the intersymbol interference. This is also known as a tail canceller circuit. When the magnitude of multipath delay, 2σ , approaches the symbol interval the tail canceller circuit is required. The circuit extends the multipath capability of the DAR, however, the modem complexity grows.

The data packing factor for the DAR is approximately 0.8 b/s/Hz due to the BW required to operate.

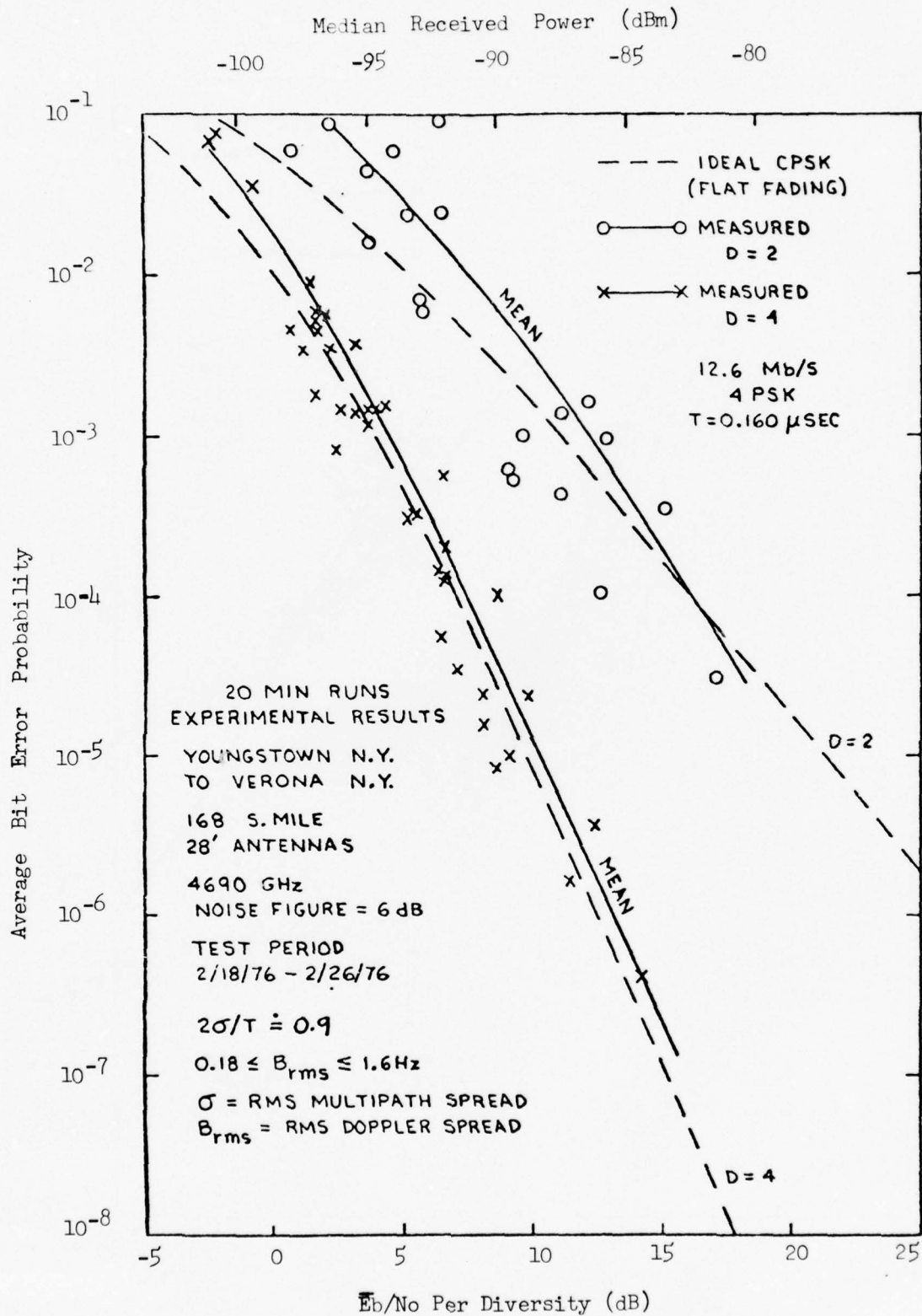

Figure 4 ADFE Modem 12.6 Mb/s Field Test Results

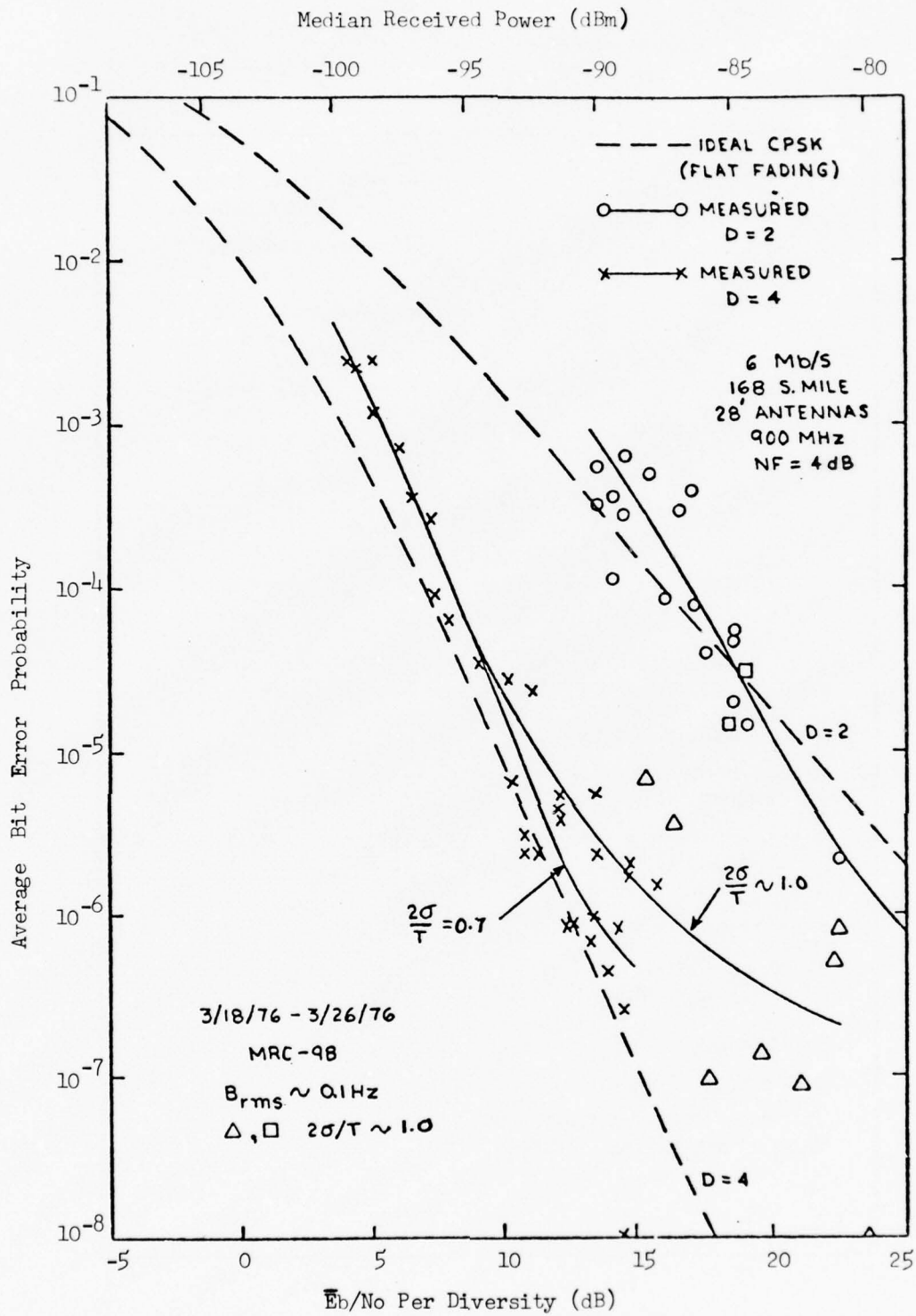

Figure 5 ADFE Modem 6.3 Mb/s Field Test Results

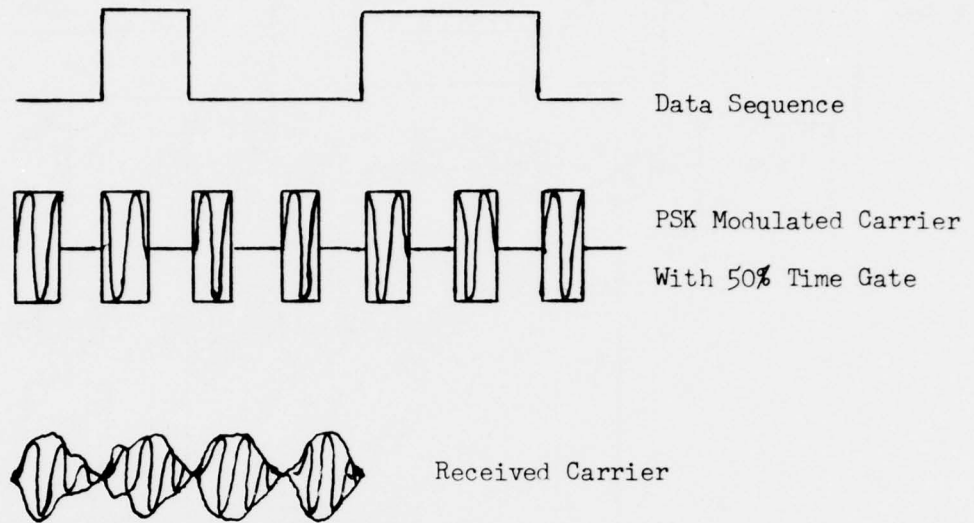

Figure 6 Basic DAR Waveshapes

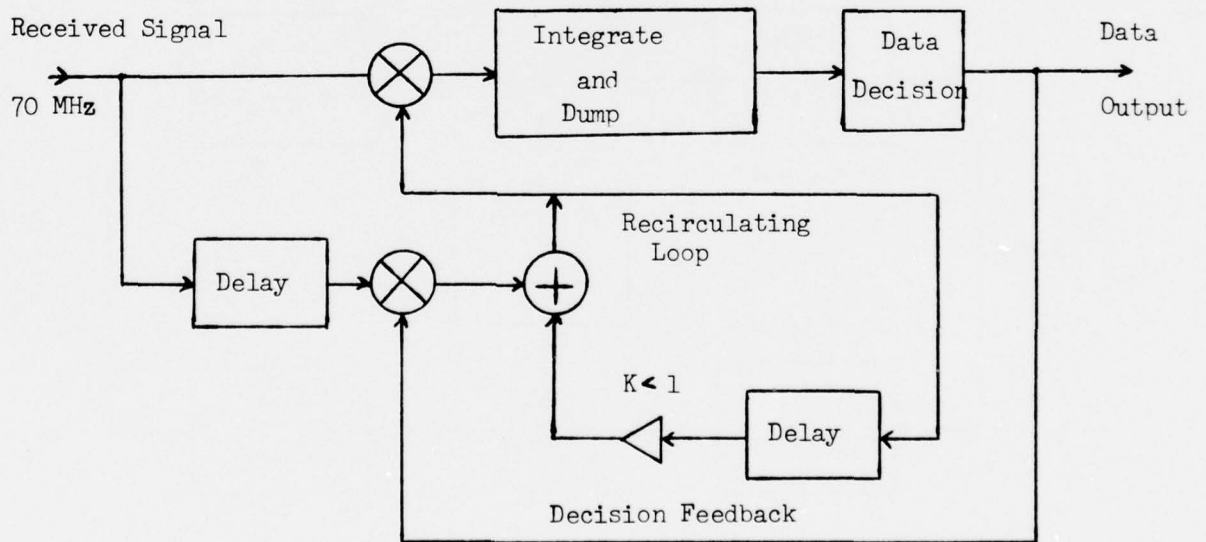

Figure 7 Basic DAR Demodulator

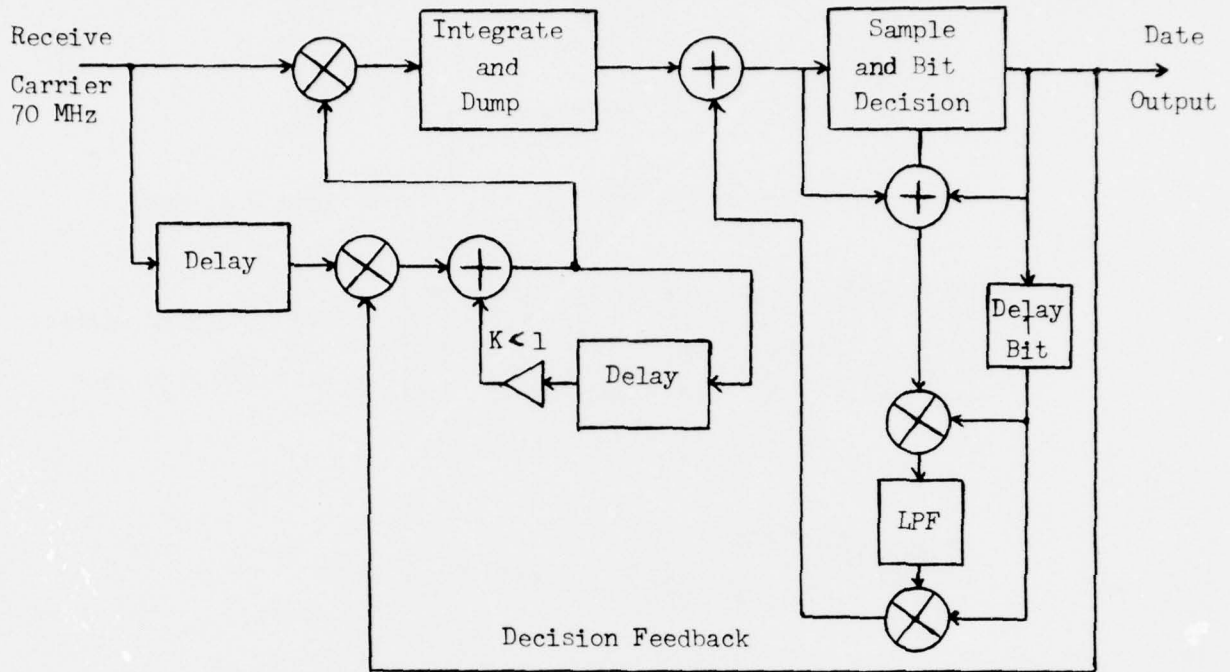

Figure 8 DAR With DFE Tail Canceler

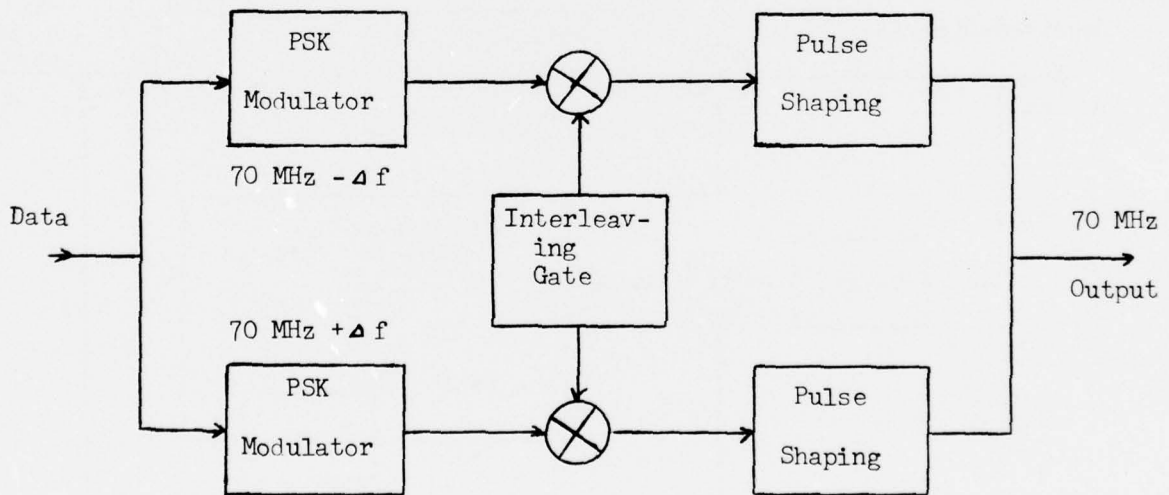

Figure 9 Interleaved Pulse DAR Modulator

Another implementation method for the DAR is an interleaved pulse approach using offset IF frequencies. This interleaving of time gated signals yields an almost constant signal envelope for transmission Figure 9. It is the DAR implementation approach taken for the TRI-TAC AN/TRC-170 family of digital tactical troposcatter radio terminals.

Test results for the DAR-IV modem, without ADE, over the air testing on the RADC upstate N.Y. link are given in Figure 10⁽⁴⁾ for 7 Mb/s quad-diversity and Figure 11⁽⁴⁾ for 3.5 Mb/s quad-diversity.

The DAR-IV modem was developed by the Department of the Air Force (RADC) under Contract F30602-73-C-0273.

c. Combined Coding and Modulation Approach: A modem technique utilizing a data interleaved (24, 12) Golay code and a channel measurement probing signal with Viterbi decoding algorithm has been developed.⁽⁵⁾

A block diagram of the modem is shown in Figure 12. Input data is coded and interleaved, 12 information data bits interleaved with 12 parity bits, then combined with a pseudo-random (PN) channel probing sequence. A single resulting data stream QPSK modulates a 70 MHz IF carrier. At the receiver the 70 MHz IF signal from the radio receiver is amplified and down-converted to baseband. In-phase and quadrature baseband channels are detected. This received digital information contains the PN channel probing information bits. The received PN bits are compared to a locally generated PN sequence, identical to the transmitter PN sequence. Cross-correlation yields bit sync information and the metrics (distances) needed to implement the maximum likelihood demodulator using the Viterbi algorithm. The received data bits are then fed to the channel measurement decoder to remove the (24, 12) Golay code. This last step employs a Chase⁽⁶⁾ developed algorithm.

The use of interleaving allows the randomization of errors, i.e. breaking up long error bursts into small blocks which can be handled by coding. The use of a (24, 12) Golay code is for error correction but it also is a form of time diversity allowing the modem to gain a performance advantage over an uncoded sequence. The Viterbi decoding algorithm uses the troposcatter channel as a time varying convolutional encoder therefore giving the modem an in-band frequency diversity improvement.

With a 2.3 Mb/s information data rate input to the modem the Golay 1/2 rate code increases the transmitted data rate to 4.6 Mb/s. Use of the channel probing PN sequence in addition to coding causes the 2.3 Mb/s information rate to increase to 5.5 Mb/s transmission data rate.

BER versus E_b/N_0 results of over-the-air testing on the RADC 168 mile test link are given in Figures 13 and 14.⁽⁷⁾ Figure 13 shows performance with and without (24, 12) Golay coding and interleaving. Figure 14 shows results with and without Multiple Rate Coding. Data for Figure 13 was taken with a 2.66 MHz 70 MHz IF filter yielding nearly a 2 b/s/Hz data packing factor for the 4.6 Mb/s 1/2 rate coded transmitted signal and nearly a 1 b/s/Hz factor considering the information data rate of 2.3 Mb/s.

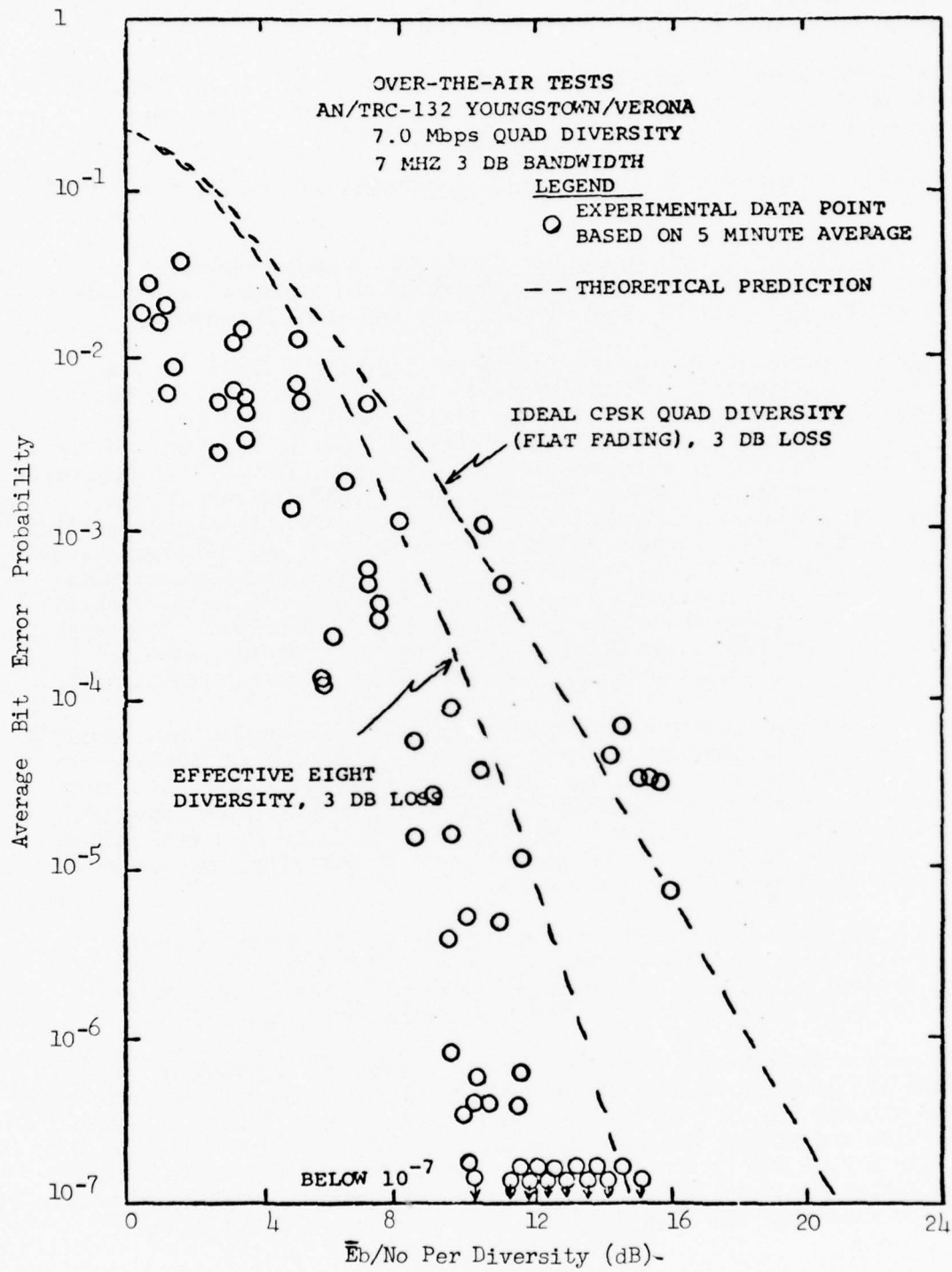

Figure 10 DAR IV Modem 7 Mb/s Field Test Results

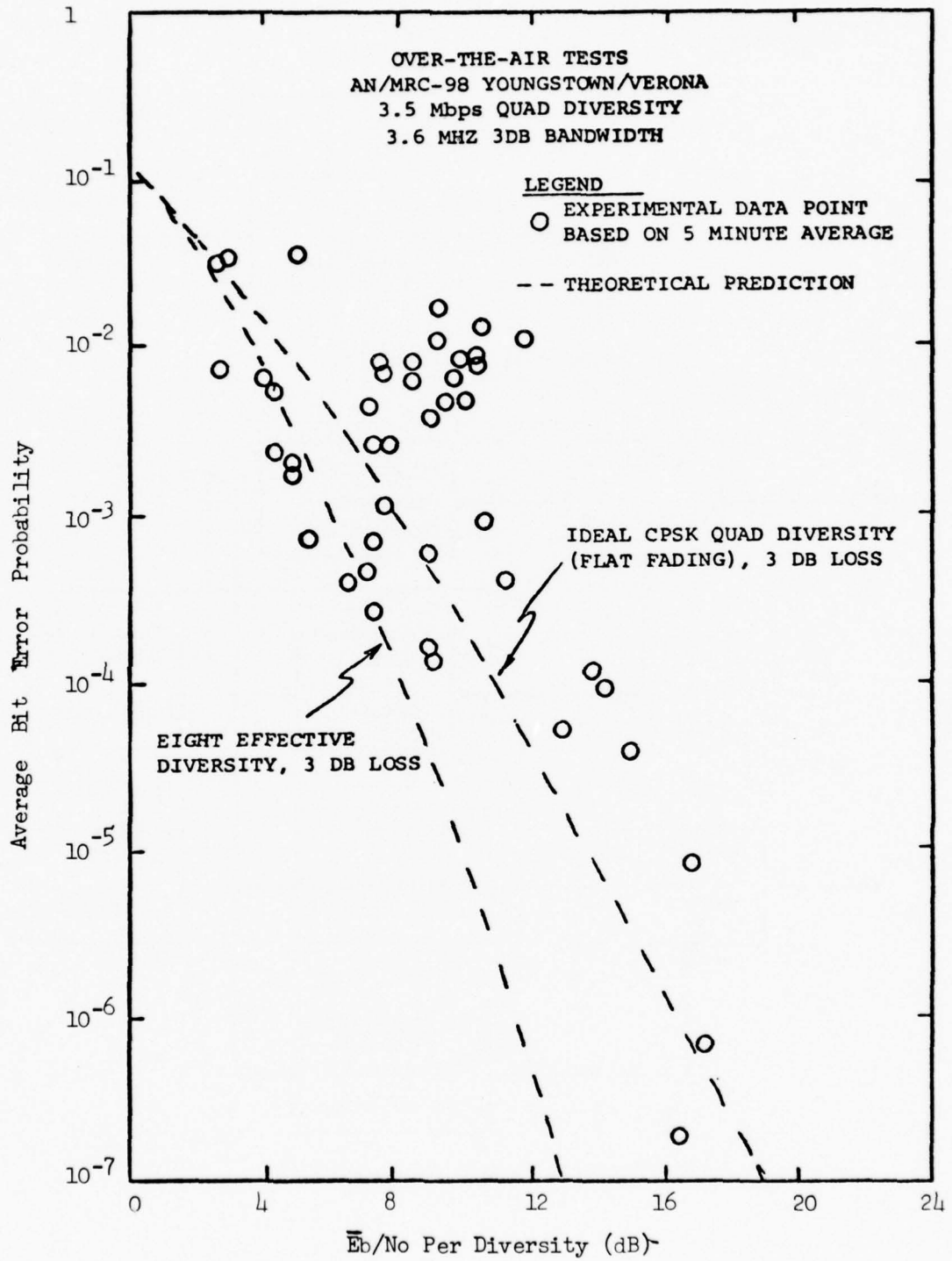
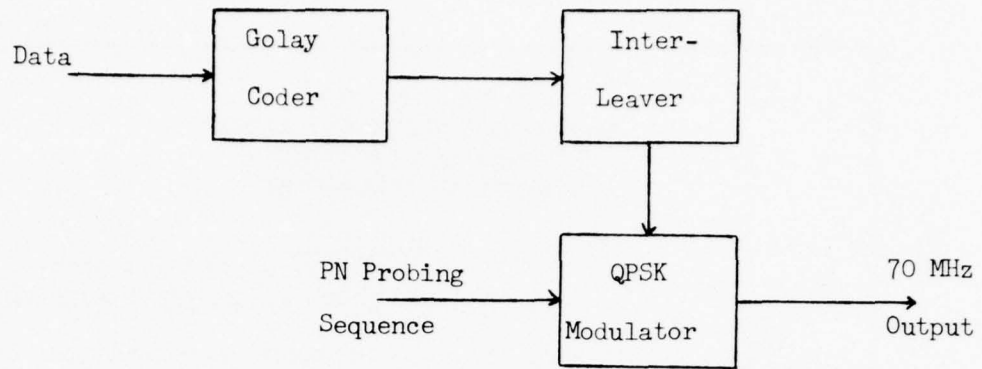
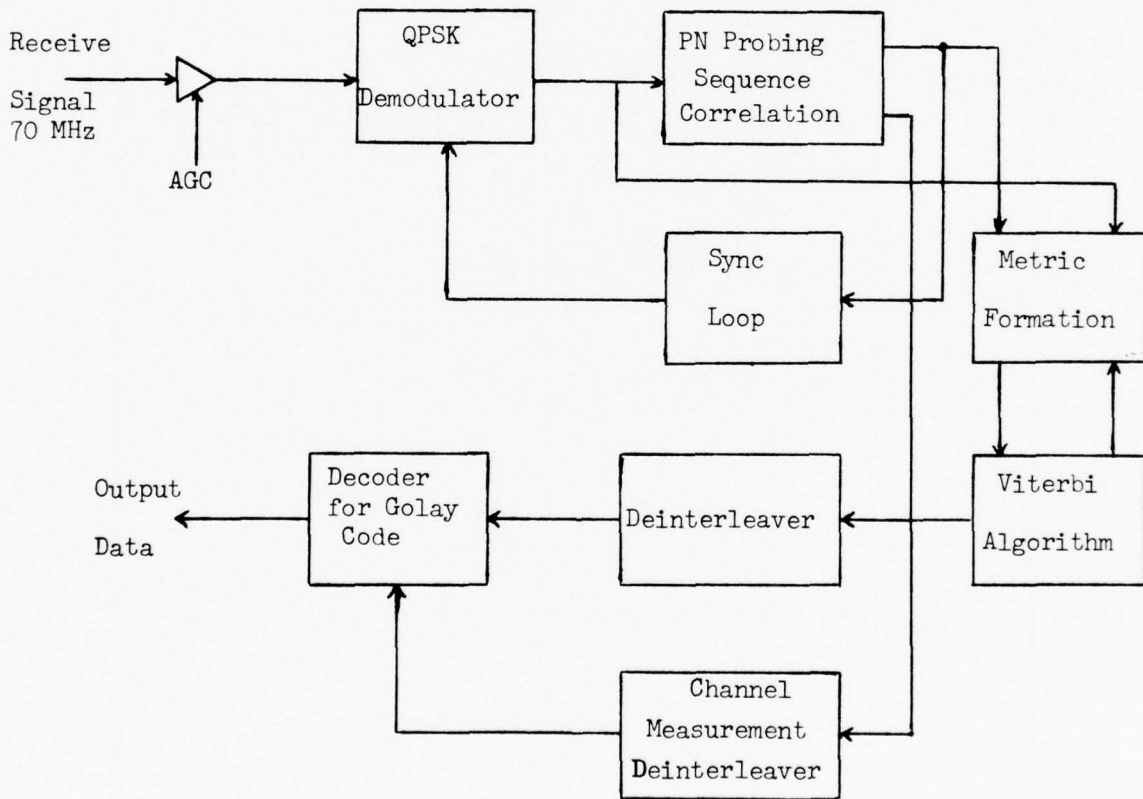

Figure 11 DAR IV Modem 3.5 Mb/s Field Test Results



a. Coder and Modulator



b. Demodulator and Decoder

Figure 12 Combined Coding and Modulation Approach Modem

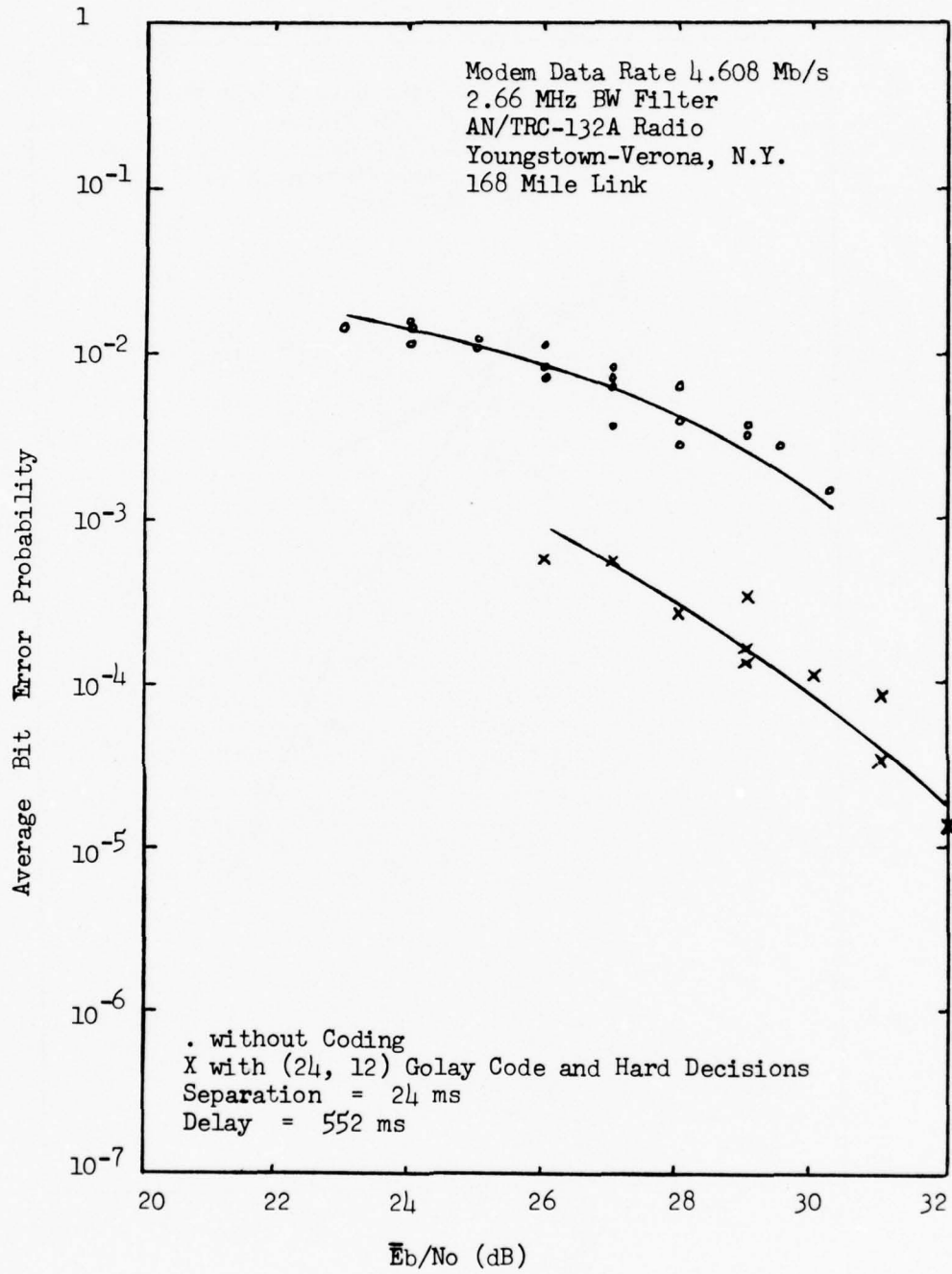

Figure 13 Coding Modem 4.6 Mb/s Field Test Results

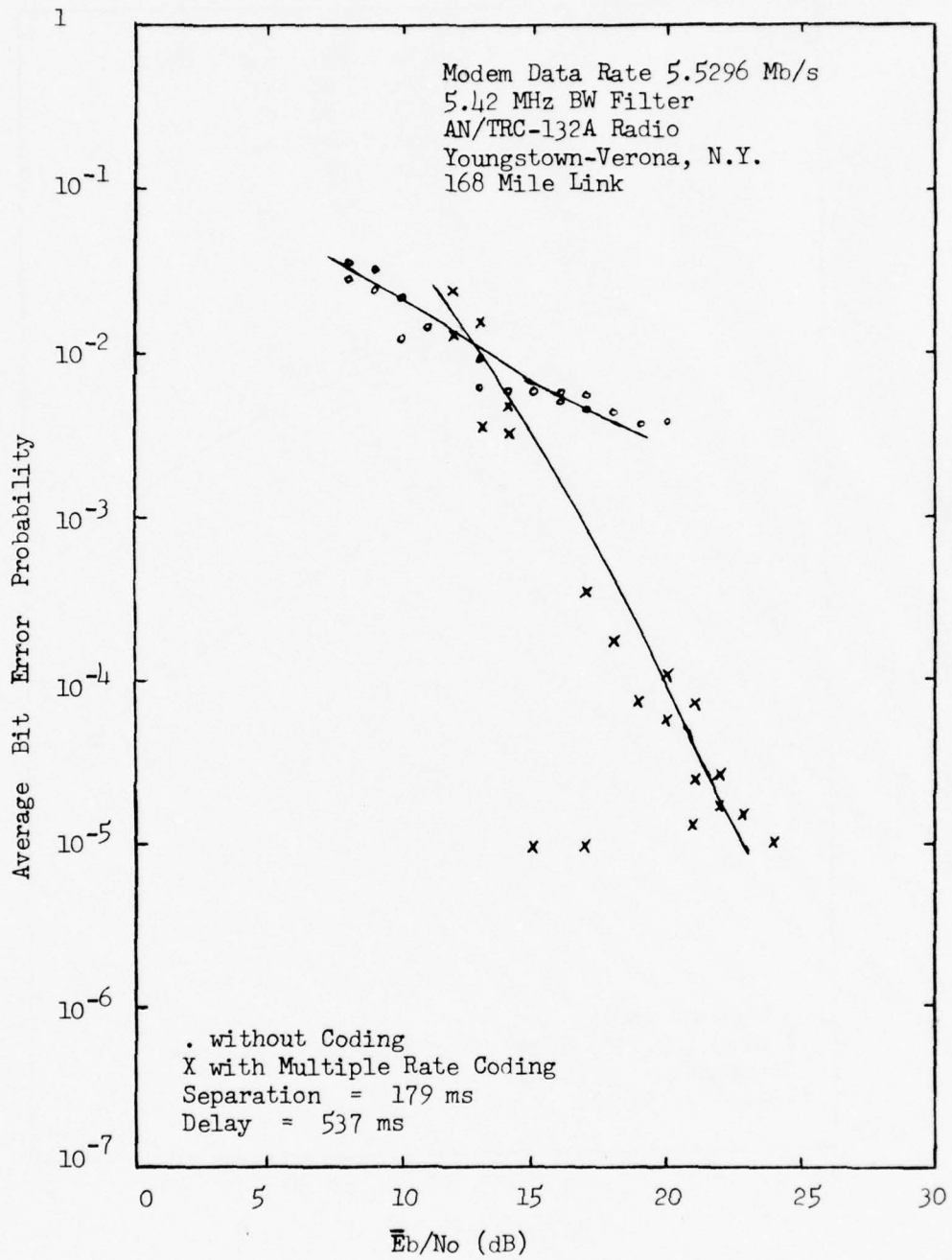

Figure 14 Coding Modem 5.53 Mb/s Field Test Results

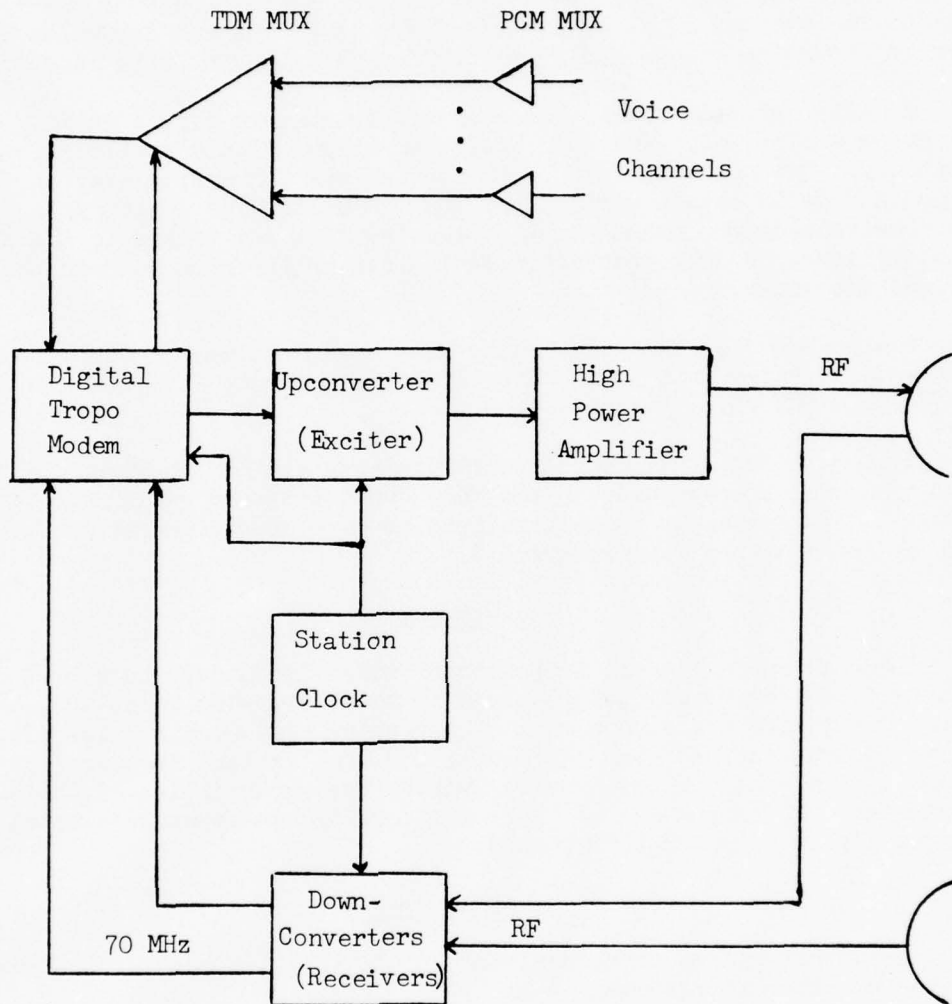

Figure 15 General Digital Troposcatter Terminal

Interfaces

A general dual diversity strategic or tactical digital troposcatter terminal is shown in Figure 15. The modem interfaces with a multiplexer or other data source at baseband and supplies a modulated 70 MHz IF carrier to the radio equipment for transmission. On the receive side the modem accepts the outputs of diversity receivers at 70 MHz and demodulates the carrier providing the multiplexers or receive data sink with baseband data.

A master station clock, accuracy of better than 1 part in 10^8 , supplies the modem and radio up and down converter stages with a stable reference frequency. The modem can supply timing for the TDM multiplexer on the transmit side or obtain timing from the TDM multiplier output data. On the receive side the modem supplies receive data and timing to the TDM demultiplexer. A bulk encryption device can be inserted between the TDM mux and the modem.

The modems discussed previously have been designed to operate at nominal data rates from 1.5 Mb/s to 12.6 Mb/s corresponding to from 24 to 192 64 Kb/s PCM voice channels.

Systems tests of equipment configurations similar to Figure 15 have been conducted successfully on the RADC CONUS test bed and on two OCONUS NATO ACE HIGH system troposcatter links as part of the Combined US/NATO Digital Troposcatter Test Program.⁽⁸⁾

Summary

Three advanced digital troposcatter modem techniques have been described. Each is distinctly different in terms of modulation-demodulation technique. However, all have the common goal of achieving high quality, low BER, digital communications over the fading and time variant troposcatter channel. Over-the-air test results verify the capabilities of these techniques. Effective use of in-band diversity was shown to have an important part in modem performance.

Acknowledgement

The author wishes to acknowledge Mr. I. Kullback and Mr. C. Grzenda for their editorial efforts.

References

1. P. A. Bello, "A Troposcatter Channel Model", IEEE Trans Communications Technology, Vol. COM-17, pp 130-137, April 1969.
2. A. R. Sherwood and I. A. Fantera, "Multipath Measurements Over Troposcatter Paths With Application to Digital Transmission", 1975 National Telecommunications Conference Proceedings, Volume II, pp 28-1 to 28-5.
3. ECOM-74-0040-F, "Megabit Digital Troposcatter Subsystem (MDTS)", Final Report, GTE Sylvania and Signatron, Inc., April 1977.

4. RADC-TR-76-250, "Hybrid Tropo Transmission System", Final Report, Raytheon Co., August 1976.

5. P. A. Bello and D. Chase, "A Combined Coding and Modulation Approach For High Speed Data Transmission Over Troposcatter Channels", 1975 National Telecommunications Conference Proceedings, Volume II, pp 28-20 to 28-24.

6. D. Chase, "A Class of Algorithms for Decoding Block Codes With Channel Measurement Information", IEEE Trans. on Information Theory, January 1972.

7. RADC-TR-76-213, "Troposcatter Interleaver", Final Report, CNR Inc., July 1976.

8. Defense Communications Engineering Center and Shape Technical Center, "Combined Digital Troposcatter Test Plan", October 1976.



BIOGRAPHY

Walter J. Cybrowski, Jr. was born in Orange, N.J. on May 29, 1948. He received the AAS degree in Electronics Technology, the BSEE and MSEE degrees from Monmouth College, West Long Branch, N.J. in 1968, 1971 and 1974 respectively.

His interests are in microwave communication systems and digital modulation techniques. He is currently a project engineer on programs to develop advanced digital modems and high power amplifiers for strategic and tactical troposcatter radio systems.

Mr. Cybrowski is a member of Eta Kappa Nu, Sigma Pi Sigma and the IEEE.

THE COMBINED US/NATO DIGITAL TROPOSCATTER TEST PROGRAM

John L. Osterholz

DEFENSE COMMUNICATIONS ENGINEERING CENTER

RESTON, VIRGINIA 22090

ABSTRACT

The US and NATO have successfully completed a cooperative test program in which two prototype digital troposcatter modems, the MDTs and DAR, were tested over communications grade troposcatter links in a system configuration. NATO provided two links of the NATO owned ACE High troposcatter system, a medium length trans-alpine link and a short diffraction link. The US provided the prototype digital troposcatter modems and associated TDM and PCM equipments along with specialized test equipment. NATO has responsibility for the analog interface between the prototype modems and the ACE High radio equipment. The US had primary responsibility for the digital interfaces between the modems, TDM, PCM and specialized test equipment. Test direction and data analysis responsibilities were shared by the Defense Communications Engineering Center (DCEC) and SHAPE Technical Center (STC). The US Army and Air Force provided the modems, TDM/PCM equipment, test instrumentation and technical support.

INTRODUCTION

The Combined US/NATO Digital Troposcatter Test Program was chartered to provide megabit digital troposcatter transmission system performance data on communications grade links. This data was required for the following reasons:

- To verify existing methods and, if necessary, to develop new methods for reliably predicting digital troposcatter performance on the basis of measured and predicted RF link performance.
- To provide a statistical data base to characterize digital troposcatter channels and user services.
- To gain experience with the operation of digital troposcatter links and systems under realistic conditions.
- On the basis of the above, to confidently establish the feasibility of digital troposcatter transmission in both DCS and NATO ACE High systems.

- To establish a basis for additional theoretical and experimental activities concerning digital troposcatter transmission, as required.

The test effort described herein encompassed a 7 month, 24 hour a day system test of two digital troposcatter modem prototypes and was accomplished between January and August 1977. The links utilized in this test program are part of the operational analog NATO ACE High troposcatter system which were removed from service for the test period.

The test program required system level testing at nominal digital transmission rates of 3.5, 7.0, and 9.4 Mb/s. Digital Time Division Multiplex (TDM) equipments used in this program were either DCS inventory equipments or prototype models which are functionally similar to equipments likely to be used in NATO or DCS digital transmission systems.

TEST LINK CONFIGURATIONS

Link Characteristics

The Combined US/NATO digital troposcatter system utilized two links of the NATO ACE High troposcatter system. The first test link was a 287.5 km trans-alpine test link operating in the 780-960 MHz frequency band. Pertinent link characteristics and a path profile are contained in Figure 1. The RF equipment in place on this link was retained for the test and is equivalent to that found in the DCS. The second test link is a 170.2 km diffraction link within a Federal Republic of Germany operating in the 4.4 - 5.0 GHz frequency band. Pertinent link data and a path profile for this link are provided in Figure 2. Both test links were engineered and installed by Marconi, Ltd. in the 1965-1969 time frame and have consistently demonstrated high reliability as analog troposcatter links.

Digital Test System

Two major configurations were utilized on the test links depending on their transmitted data rate. The first configuration, illustrated in Figure 3, was used for system level test and was operated at a nominal data rate of 6.3 Mb/s. In this configuration, the AN/GSC-24 Asynchronous TDM was used to multiplex inputs from US and NATO (CCITT Compatible) PCM channel banks along with a high rate (1.544 Mb/s) pseudo random bit stream. This configuration enabled the collection of system performance data relating to PCM channel outage statistics and PCM/TDM synchronization stability. The second configuration, as shown in Figure 4, was used for 3.5 Mb/s DAR and MDTS link tests and 9.4 Mb/s MDTS link tests. This configuration facilitated the collection of digital troposcatter modem/RF subsystem performance data. MDTS and DAR digital orderwire capabilities were integrated with the station facilities and used for both test and operational ACE High purposes.

Transmitted bandwidth constraints imposed on the MDTs and DAR for the test program are given in Table 1. It was the objective of the test program to make available the necessary bandwidth for each technique. The larger question of bandwidth availability for actual DCS/NATO implementations, while not addressed by this program, is currently under study by DCEC and ECAC.

TABLE 1. TRANSMITTED BANDWIDTH (BW) CONSTRAINTS

<u>MODEM</u>	<u>DATA RATE</u>	<u>BW (99 PERCENT)</u>
MDTS	3.2	3.5
	6.3	7.0
	9.4	7.0
DAR	3.5	7.0
	7.0	10.5

Data Acquisition System

The Data Acquisition System (DAS) utilized in this test program was assembled primarily from equipment already in US and NATO inventories thus avoiding a major custom instrumentation effort. STC did, however, fabricate a multichannel digital tape recorder which was effectively used to collect fine grained performance data for off line analysis by DCEC and STC. A functional level block diagram illustrating the major elements of the DAS is shown in Figure 5.

TEST RESULTS

This section summarizes the major test results which have been validated to date. DCEC and STC will coauthor a comprehensive test report which will provide a more detailed analysis to support these results.

Link Analysis

Received Signal Level (RSL) statistics for the trans-alpine test link, IDGZ-AFEZ, are presented in Figure 6 along with the predicted RSL distribution for the link. Excellent agreement with predicted values was obtained with receiver 4 while only moderate agreement was measured with receiver 2. Receivers 1 and 3, however, were seen to deviate significantly from the predicted RSL distribution. Analysis of the short term RSL distributions for all receivers has indicated that a specular (non-fading) component was present in varying amounts in all four diversity received signals. As typified by Figure 7, the ratio of specular to scatter signal power is seen to vary from near 0dB (mostly scatter) in the case of receiver 4 to almost 15 dB (mostly non-fading) in the case of receiver 1. This observation is supported by Figure 6 which shows receiver 1 and 3 having

higher long term median signal levels and smaller standard deviations than receivers 2 and 4. These distributions are characteristic of a forward scatter path with a large non-fading component. The propagation mechanism which caused this behavior is currently under study. A possible explanation for this phenomenon is double knife edge diffraction, although it is unlikely that the path profiled in Figure 1 will support this conclusion. A more plausible explanation may be that off axis reflection/diffraction is responsible for this phenomenon since it appears to be highly space selective.

Diversity branch envelope correlation coefficients were calculated on the basis of measured data for all diversity paths. In every case almost total short term decorrelation of diversity RSL was noted. As an example, Figure 8 is a scatter plot of RSLs measured in receivers 2 and 4 over a 24 hour test day and containing over 4×10^5 individual data points. The envelope correlation coefficient calculated from this data was .06.

Multipath data for the IDGZ-AFEZ trans-alpine link was not directly obtained due to the unavailability of a multipath analyzer. However, the backward equalizer control voltage of the MDTs was found to provide a reasonable indicator of the amount of multipath dispersion present on the link and therefore this voltage was recorded. The final analysis of multipath dispersion statistics for this link has not been completed at the date of this submission. A preliminary analysis indicates that the Root Mean Square (RMS) multipath dispersion measured on the trans-alpine link was much greater than the originally predicted value. A review of the propagation data supports this analysis. It is likely that the actual link exhibited a composite multipath profile such as that illustrated by Figure 9 where the mixing of specular and delayed scatter components resulted in a large overall delay spread. The total differential time delay measured from the specular signal component to the extrema of the troposcatter delay profile can easily result in a total multipath spread almost twice that predicted for the troposcatter propagation mode alone. Additionally, the total multipath spread was seen to have a diurnal variation which coincided with increased fading activity of the link thus indicating that as the link began to fade it also became dispersive.

Data on the 4.4-5.0 GHz diffraction test link has not been analyzed at the date of this submission. Supplementary material will be provided as it becomes available.

Digital System Performance

Digital performance data on both the MDTs and DAR prototype modems and the MDTs modem in the system configuration was collected over a seven month period from January to August 1977.

Performance of the MDTs on the trans-alpine link was measured from January to May 1977 and is summarized by Figures 10 and 11. Figures 10 and 11 represent Bit Error performance data taken with the MDTs 6.3 Mb/s system test configuration and includes the effects of occasional modem and TDM losses of Bit Count Integrity (BCI). As indicated by Figure 10, the MDTs/TDM system provided a mean Bit Error Rate (BER) of better than 10^{-5} for 99.99 percent of the test period in quad diversity. From Figure 11 it is seen that better than 85 percent of all MDTs test seconds were error free at 6.3 Mb/s. While this certainly indicates very good performance, a minor performance degradation was measured and attributed to the effects of large diversity signal differentials on the MDTs IF circuitry.

While the concept of mean Bit Error Rate is not particularly useful in the development of link engineering standards, it nevertheless provides a broad indication of the performance of digital systems. A more relevant parameter is the probability of fade outage, which is the probability that the performance of a digital channel will degrade below a specified threshold for a period of time which is noticeable to the subscriber. DCEC digital transmission system engineering is based on specifying an acceptable probability of fade outage. The final test report for the combined US/NATO Digital Troposcatter Test Program will analyze MDTs and DAR performance based on this more accurate performance parameter.

Figure 12 shows the results of MDTs performance tests at 9.4 Mb/s in a 7.0 MHz transmitted bandwidth (1.34 bits/cycle) using the link test configuration. Since the total test time spent at 9.4 Mb/s was limited, little can be said beyond the observation that usable voice communications was achieved and that the performance of the modem degraded significantly whenever the channel multipath dispersion became noticeable. These observations indicate that a significant reduction of the multipath handling capability of the MDTs was experienced as a result of transmitter bandwidth limitations and also that the remaining capability was marginally effective. However, further tests need to be accomplished to quantify the performance of the MDTs modem at RF spectrum efficiencies greater than 1.0 bits/cycle since suboptimal broadbanding of the RF equipment was responsible for much of this degradation.

DAR performance on the IDGZ-AFEZ link was measured over a one month period between 4 May and 6 June 1977. DAR performance data was collected using only the link test configuration. Because of severe bandlimiting in the RF equipment at the transmitter site, the DAR performance was mixed. Bandlimiting in the high power klystron resulted in a loss of multipath handling capability in the DAR. At 7.0 Mb/s, which is the highest data rate of the DAR, performance ranged from excellent during non-fading periods to marginal during periods when the link was fading. As all DAR test runs were accomplished at high RSLs, the DAR performance appeared to be limited primarily by an inability to accommodate the composite bandlimited radio/troposcatter channel. Figure 14 summarizes the BER performance of the DAR on the trans-alpine UHF link at 7.0 Mb/s. The DAR and MDTs modems

were also tested at the 3.5 Mb/s (nominal) transmission rate. Test data at this rate indicated that both techniques performed with essential equivalence.

Bit Count Integrity (BCI) or synchronization performance of the MDTs/TDM/PCM system configurations was monitored continually. A summary of this data is presented in Figure 13 for both dual and quad diversity. In quad diversity loss of BCI events were observed in only 4 percent of the test runs. None of these BCI losses were charged to the MDTs modem.

In dual diversity, loss of BCI events were noted in 6 percent of the test runs. Approximately one half of these events were charged to the MDTs. In all cases, however, BCI was regained in less than 50 msec. Therefore, loss of BCI was not a significant source of system degradation even in dual diversity. BCI losses at 9.4 Mb/s were more frequent and were observed in approximately 5 percent of the quad diversity tests. The increased frequency of BCI loss observed at 9.4 Mb/s (1.3 bits/cycle) was undoubtedly due to the significant intersymbol interference suffered in that configuration.

CONCLUSIONS

The results obtained in this test, when considered together with previous Army and Air Force tests, establish that toll quality megabit digital troposcatter transmission can be reliably provided over communications grade troposcatter links at RF spectrum efficiencies up to 1 bit/cycle. A troposcatter link which has provided acceptable analog service should provide noticeably improved service if digitized. Analog troposcatter links which have performed marginally can be significantly improved by the application of digital transmission. The demonstrated robustness of PCM transmission for voice communications under varying signal level conditions together with the capability to virtually eliminate periodic system and link alignment make digitization a desirable and necessary method for upgrading those troposcatter links which will be retained in the DCS. Digital troposcatter technology has matured to the point where pilot implementation can now confidently proceed.

	DOSSO DEI GALLI	FELDBERG
Station Alt	2175m	1470m
Horizon Angle	.60°	.06°
Antenna Size	27m	27m
Power Output	5 KW Nominal	
Frequency	780 - 960 MHz	
Diversity	Space/Frequency	

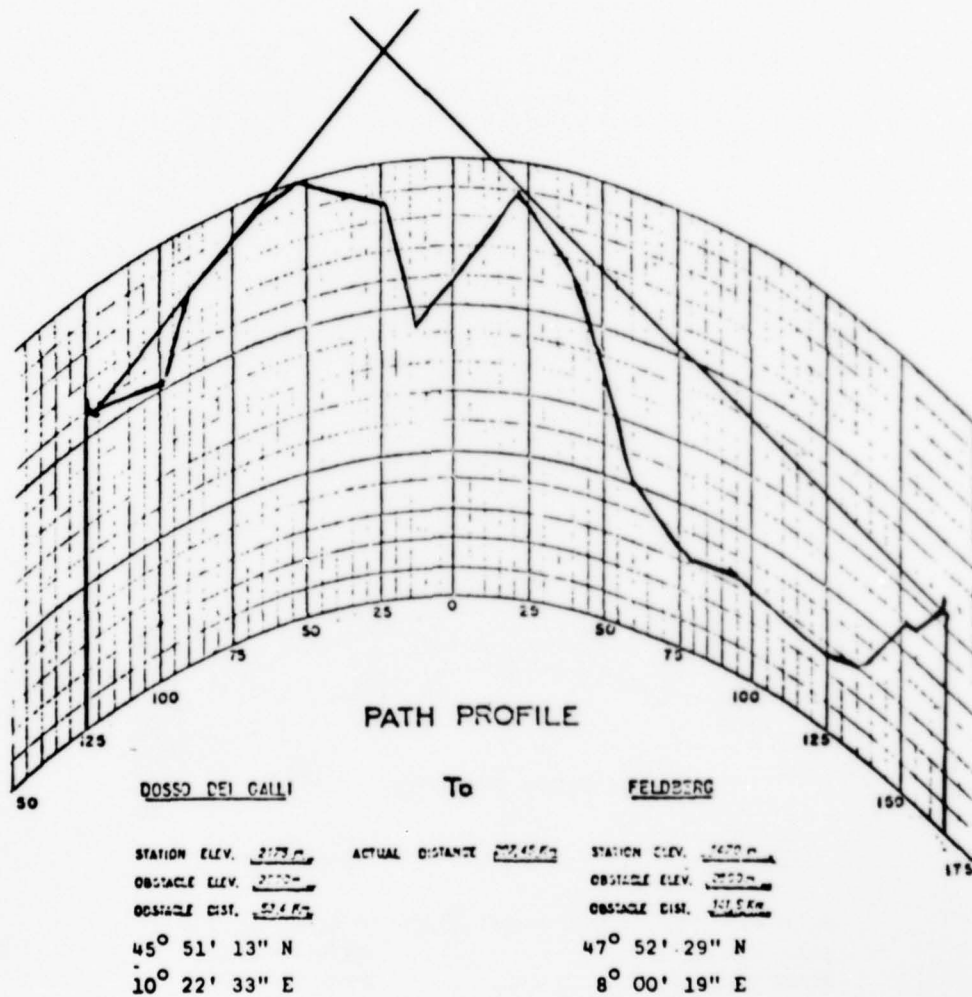
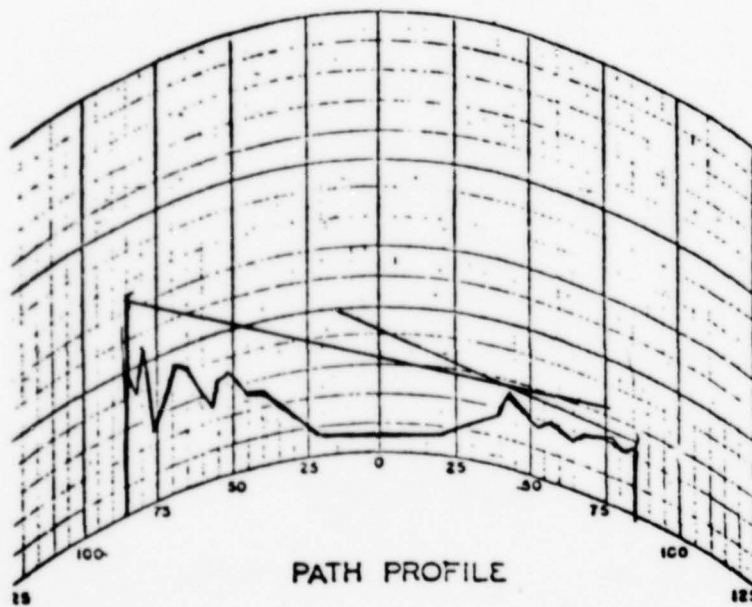

FIGURE 1. TRANS-ALPINE TEST LINK

	KINSBACH	FELDBERG
Station Alt	459m	2175m
Horizon Angle	-.09°	-.87°
Antenna Size	3.0m	3.0m
Power Output	500W Nominal	
Frequency	4400-5000 MHz	
Diversity	Quad Space	



FELDBERG

To

KINSBACH

STATION ELEV. 2175 m
 OBSTACLE ELEV. 500 m
 OBSTACLE DIST. 127.8 m

ACTUAL DISTANCE 170.2 m

STATION ELEV. 459 m
 OBSTACLE ELEV. 500 m
 OBSTACLE DIST. 62.2 m

47° 52' 28" N
 8° 00' 19" E

49° 23' 53" N
 7° 35' 45" E

FIGURE 2. DIFFRACTION TEST LINK

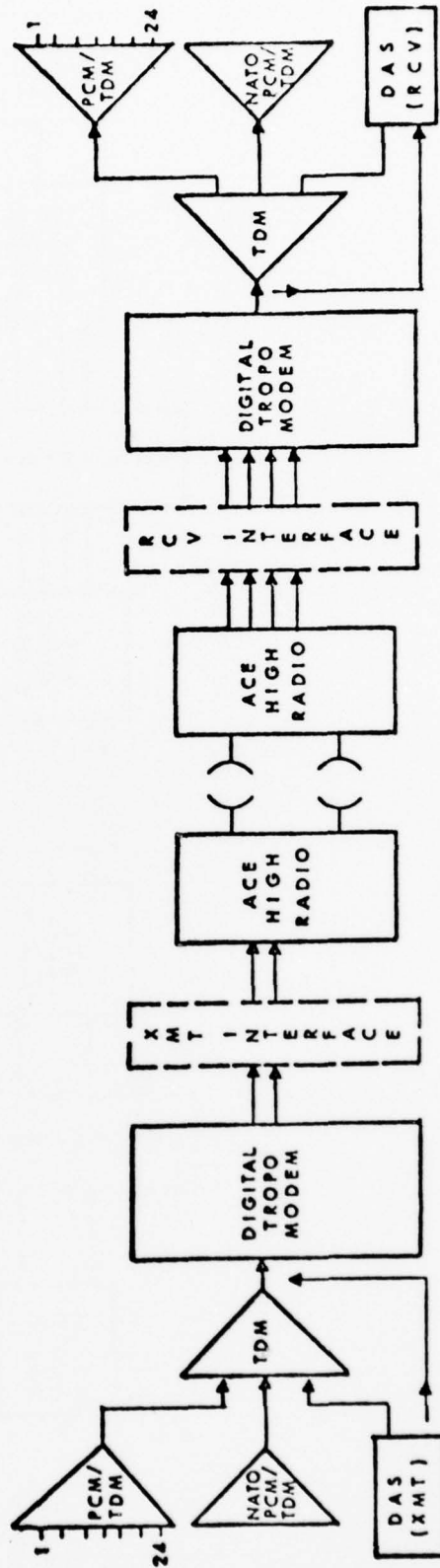

FIGURE 3. SYSTEM TEST CONFIGURATION

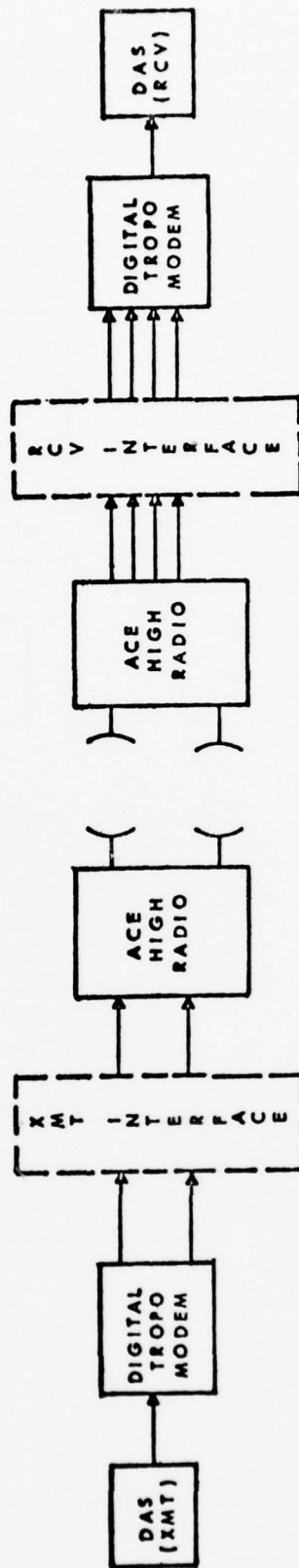

FIGURE 4.- LINK TEST CONFIGURATION

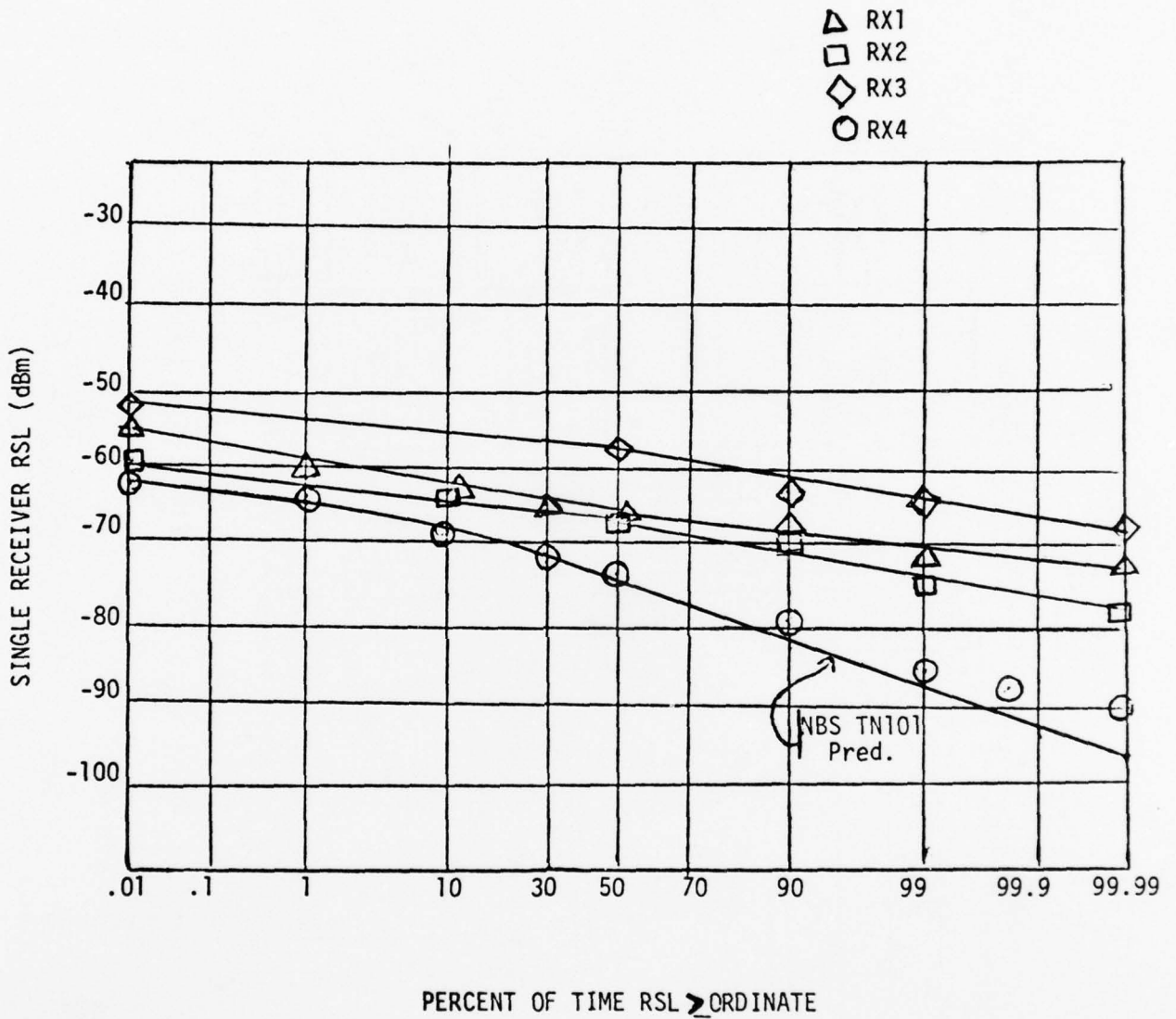
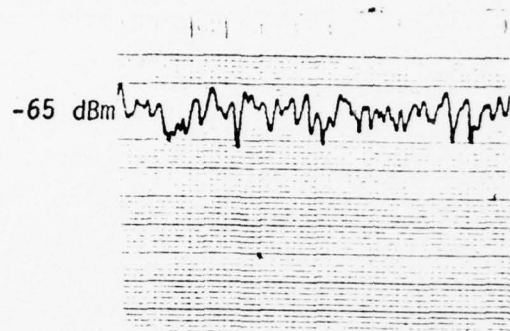
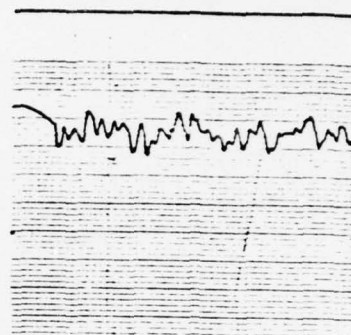

FIGURE 6. RSL DISTRIBUTION (IDGZ-AFEZ)



R X 1



R X 2

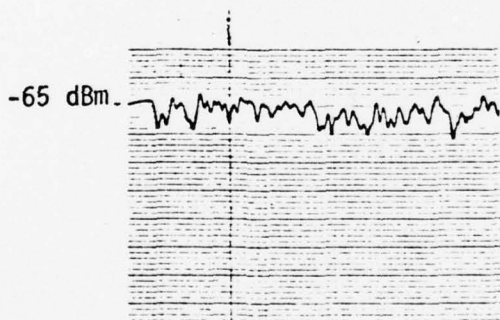

R X 3

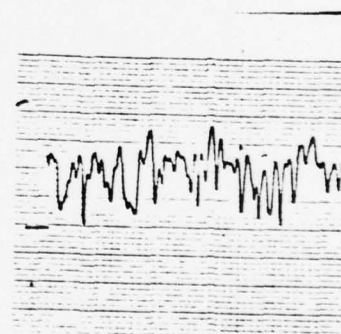

R X 4

Scale: 5 dB/Large Division
.25 mm/sec

FIGURE 7. DIVERSITY RSLs (IDGZ-AFEZ)

AD-AU44 407

ARMED FORCES COMMUNICATIONS AND ELECTRONICS ASSOCIATI--ETC F/G 17/2
PROCEEDINGS OF THE ANNUAL SEMINAR (2ND). THE ART OF COMMUNICATI--ETC(U)
SEP 77 S KREVSKY

UNCLASSIFIED

AFCEA-FM-2

NL

2 OF 2
AD
A044407



END
DATE
FILMED
10-77
DDC

44407

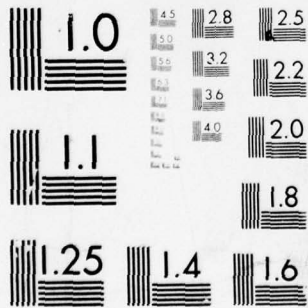

MICROCOPY RESOLUTION TEST CHART
NATIONAL BUREAU OF STANDARDS-1963-A

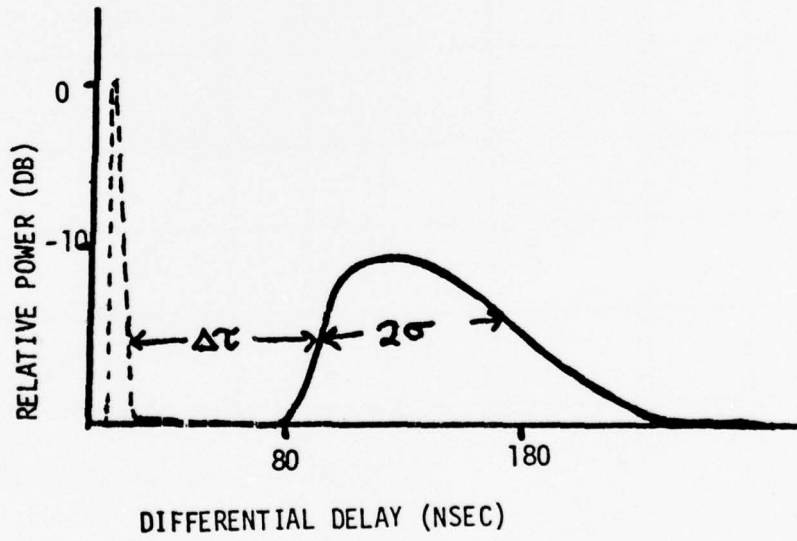
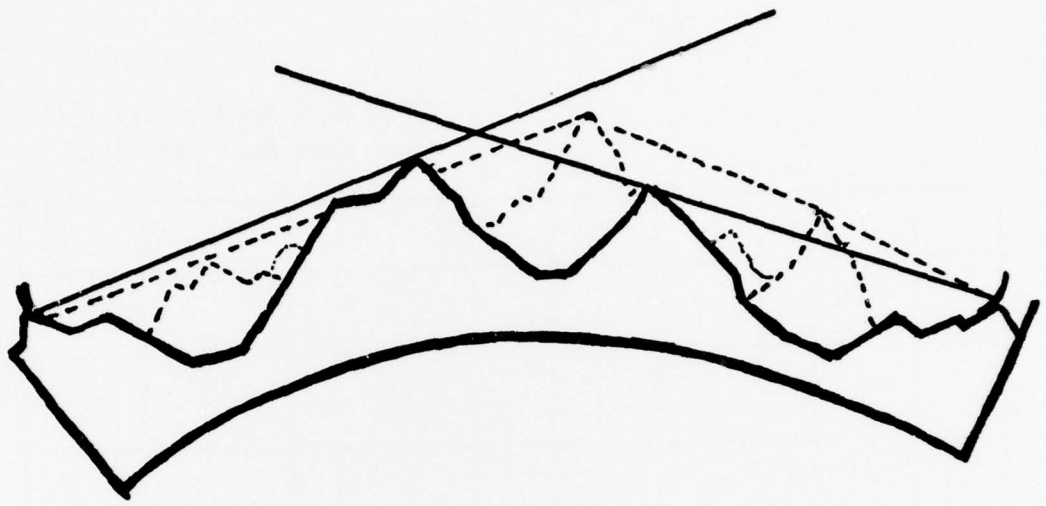

FIGURE 9. TRANS-ALPINE PROPAGATION

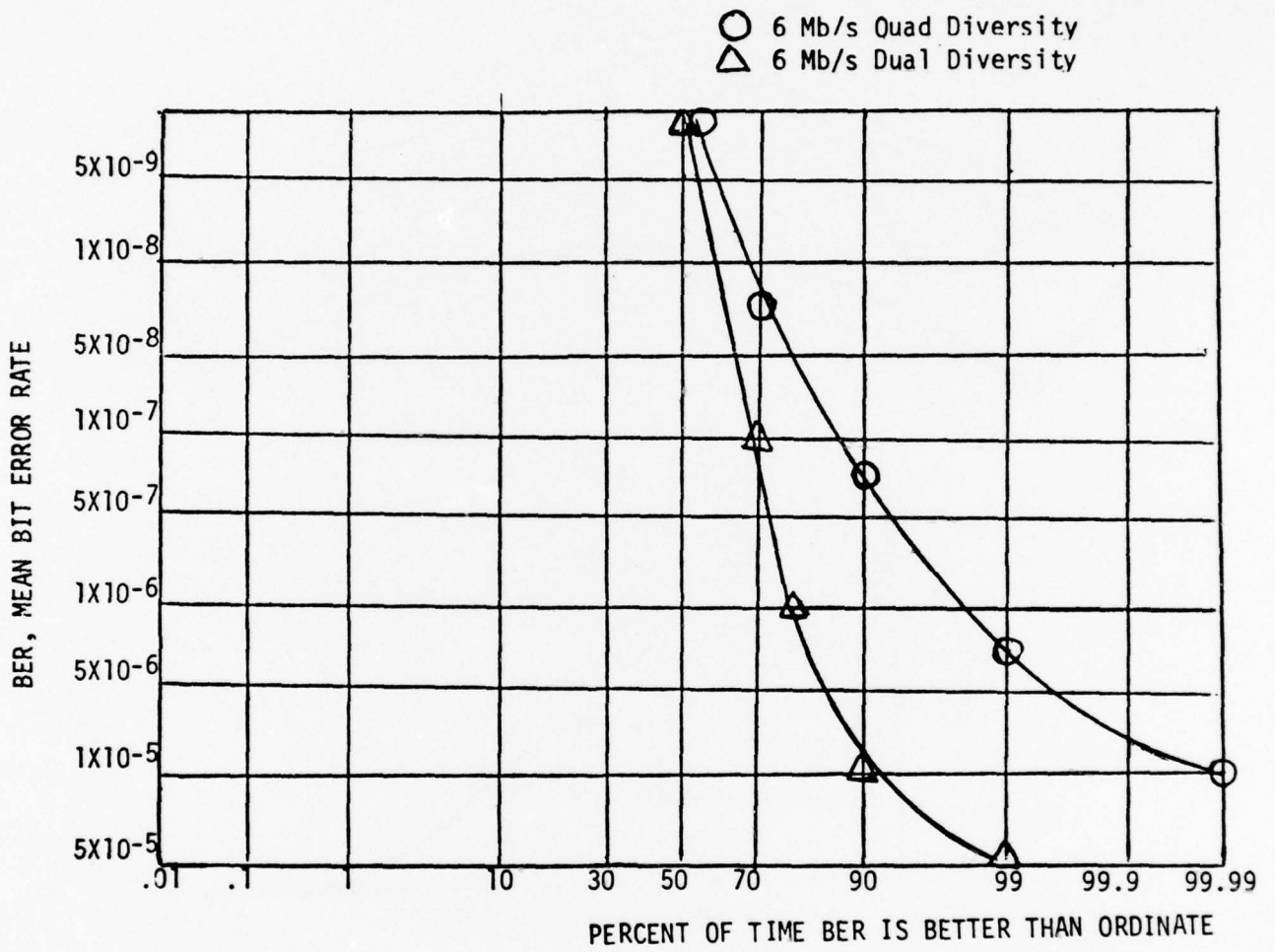

FIGURE 10. MDTS BER DISTRIBUTION (IDGZ-AFEZ)

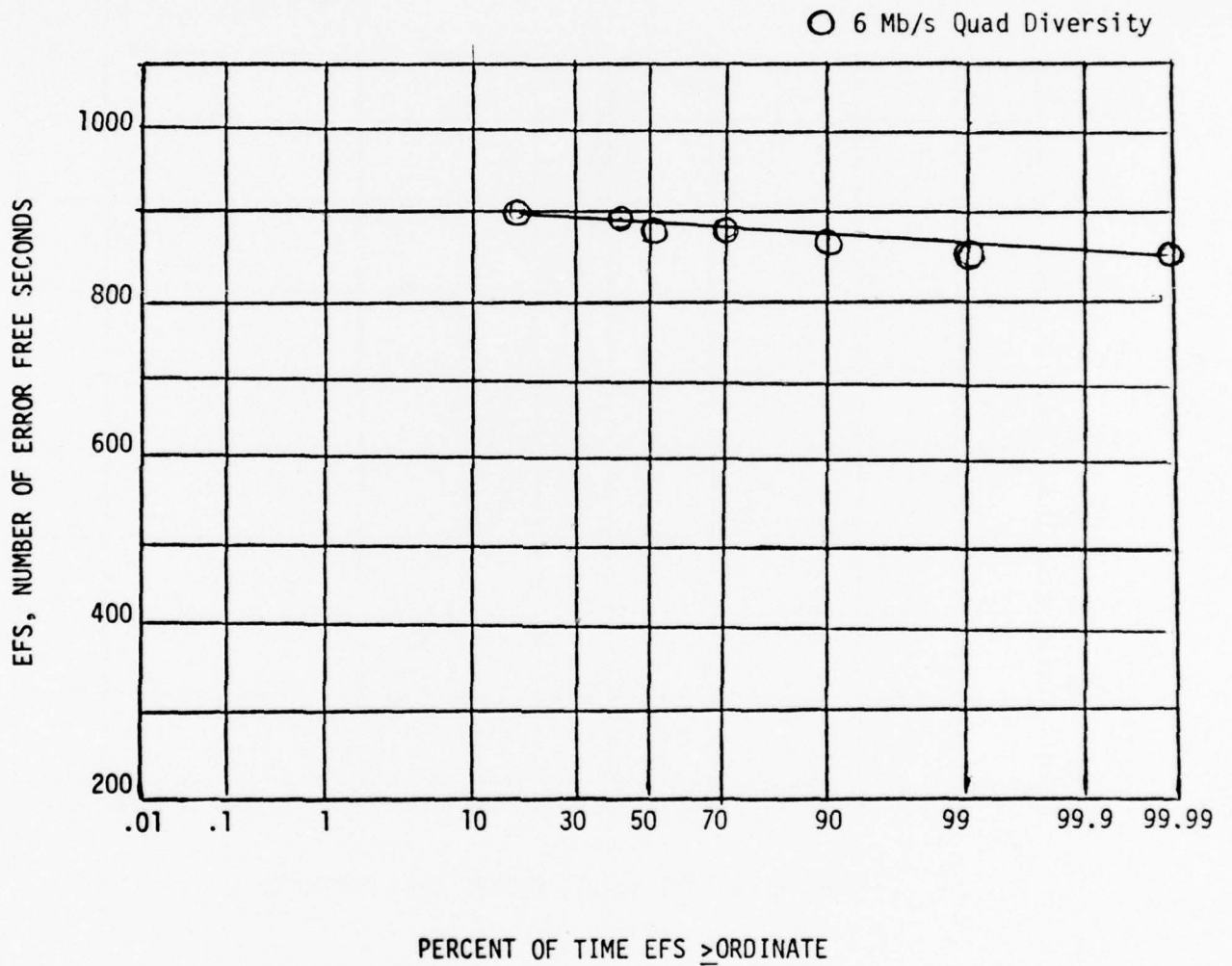

FIGURE 11. DISTRIBUTION OF MDTs ERROR FREE SECONDS (IDGZ-AFEZ)

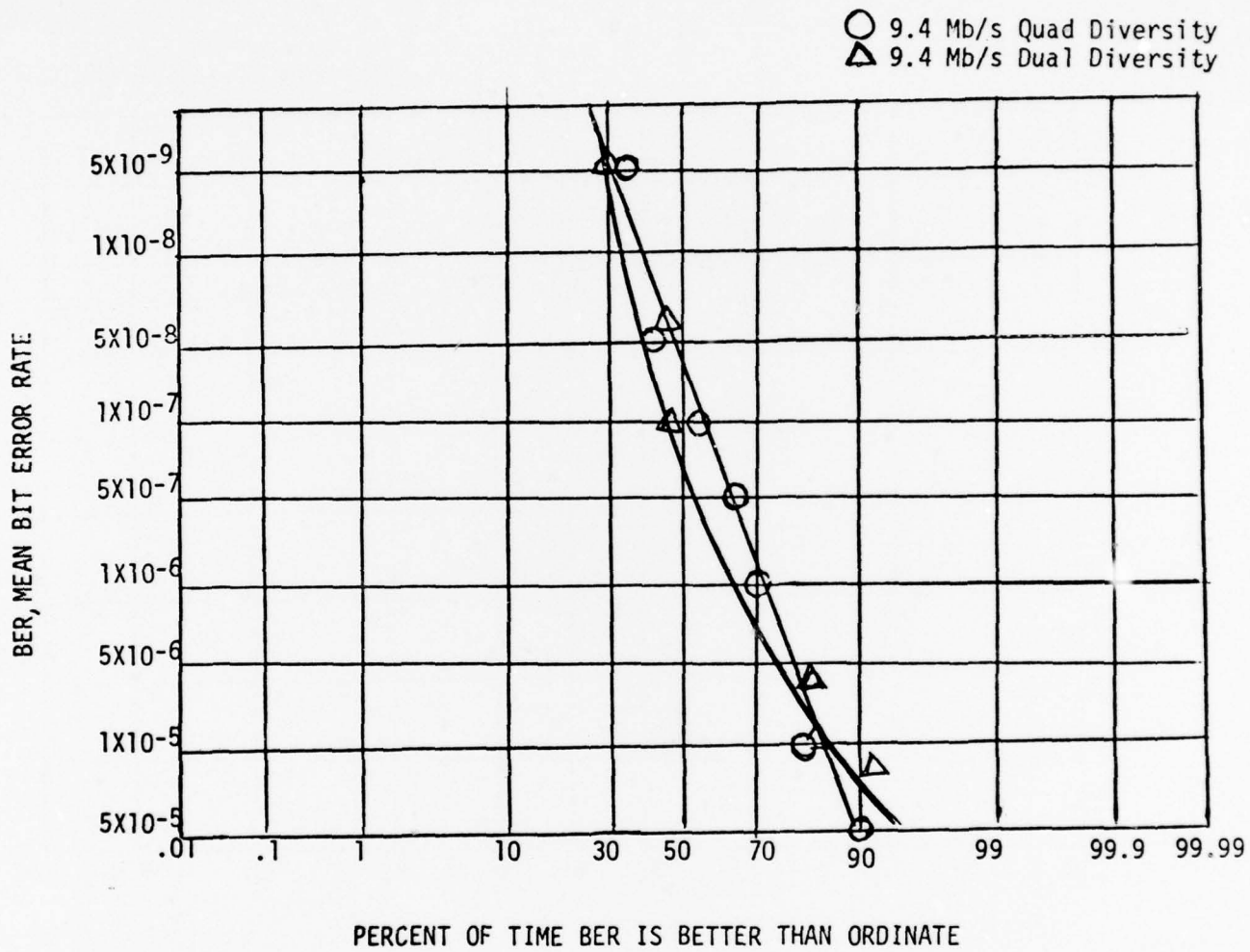

FIGURE 12. MDTs 9 MB/S BIT ERROR DISTRIBUTION (IDGZ-AFEZ)

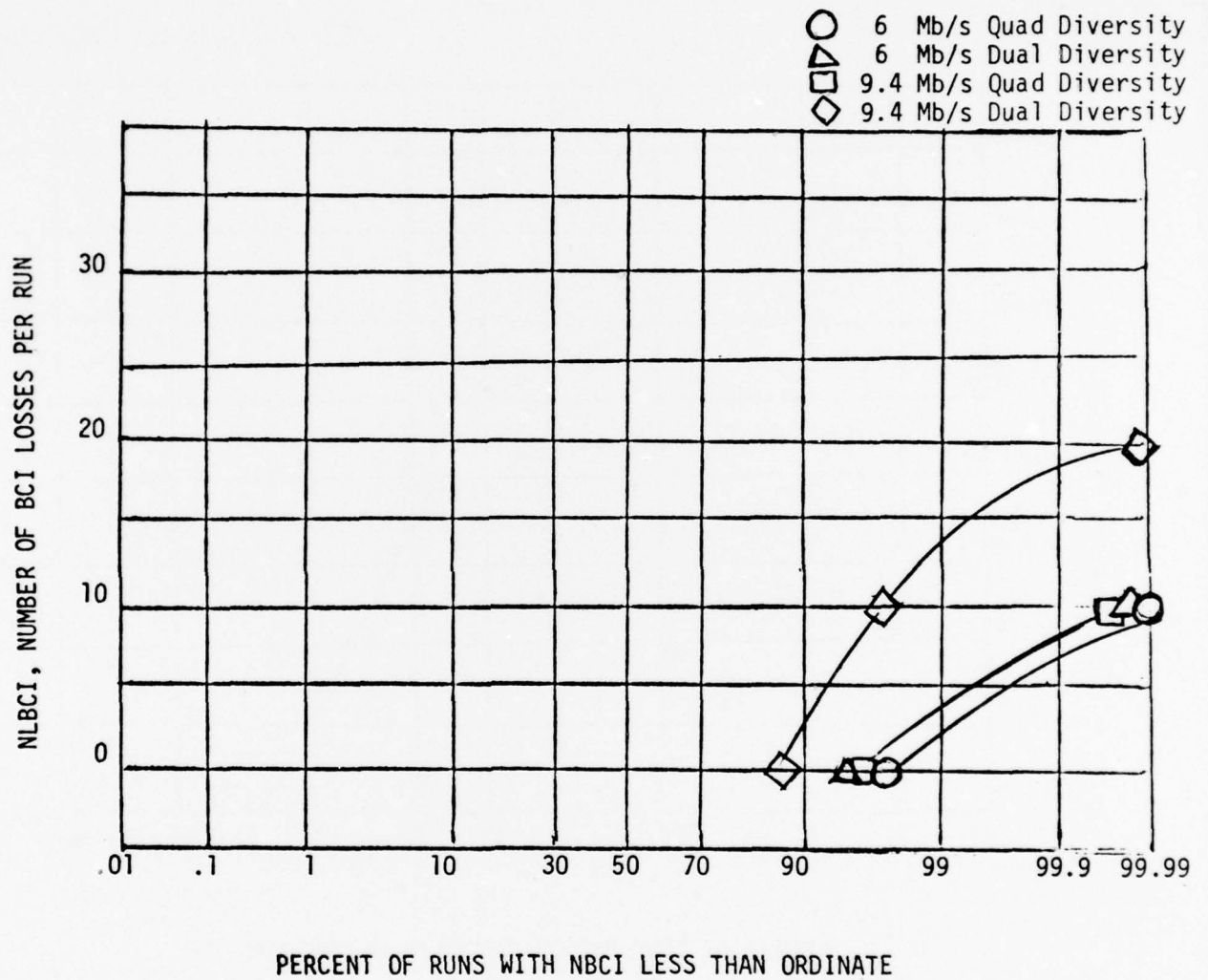

FIGURE 13. BIT PERFORMANCE

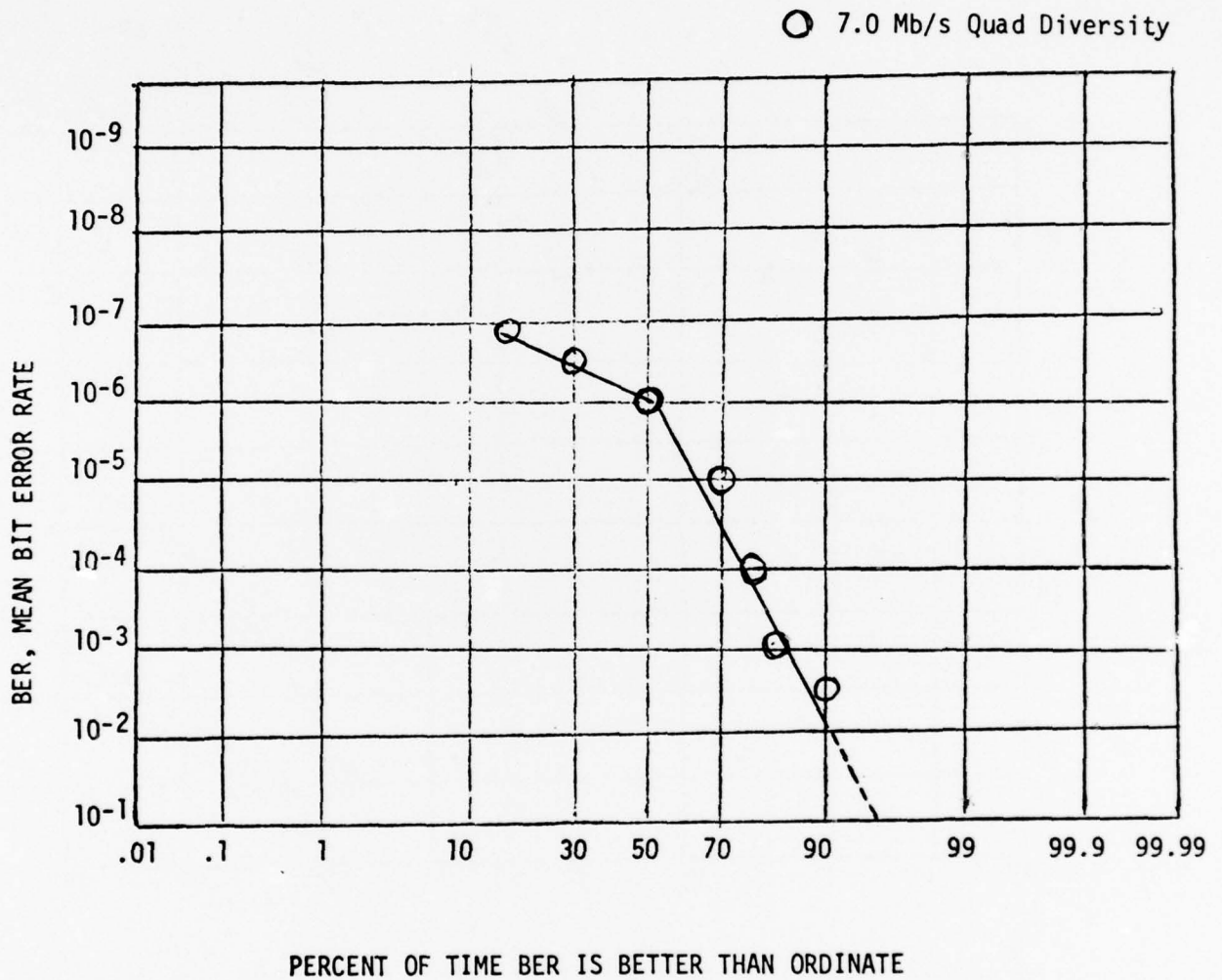

FIGURE 14. DAR BIT ERROR RATE DISTRIBUTION



BIOGRAPHICAL SKETCH

Mr. Osterholz is a senior transmission engineer at the Defense Communications Engineering Center (DCEC), Reston, VA. He has primary responsibility for the design of digital transmission systems utilizing troposcatter. Prior to joining DCEC, Mr. Osterholz was employed at the U.S. Army Electronics Command (USAECOM) where he was involved in the study and development of multichannel digital transmission technology. During his military service, Mr. Osterholz was assigned to Asmara, Ethiopia where he was responsible for the study of deep space propagation phenomena. He is an officer in the U.S. Army Reserve and is a member of the American Institute of Physics.

The Use of Graphics in a Tactical Environment

Mr. Leon Bloom, Manager Advanced Computer Systems,
Litton Data Systems, Van Nuys, California

ABSTRACT

New technology has made possible the introduction of graphic communication and display in the tactical environment. This paper describes two devices: one, a large multi-color flat panel display system; the other, a hand-held intelligent terminal, and indicates their interrelation and

their role in improving communication among various echelons of front line troops. The ability to reduce message composition time and transmission time while improving the ability to understand and take action based on the communication will be stressed.

INTRODUCTION

The importance of communications to tactical forces has been recognized since the days when jungle drums and smoke signals were the primary means employed. While elementary messages could be sent in this manner, more complex communications, particularly those that required secure transmission, were handled by messengers. Communication in modern warfare has advanced to the point where most messages are communicated by voice to the extent that two-way conversations filled the airways during WW II, Korea, and Vietnam.

While this form of communication could handle many basic messages, it left much to be desired. Shortcomings included the fact that the message transmissions were error prone and often deteriorated into lengthy two-way conversations that tied up the frequency channels, used excessive radio power, and could be easily detected or intercepted. Long transmission times made it easy for the enemy to locate and jam or destroy the transmitters. Messages were often misunderstood, and the lack of hard-copy, while somewhat alleviated by radio-teletypes, made it impossible to reconstruct what was actually said or meant by the communicators.

In the past few years, technological advancements have made possible the development of hand-held, battery-powered, digital communication devices that, when used in conjunction with voice band radios, allow the communicator to compose and edit an alphanumeric message and transmit it in a one-or-two second burst to a computer or other digital message device. There the message can be received, displayed, and, if necessary, printed.

Fixed format messages have been developed that handle most of the basic needs and also reduce composition and transmission time. The shortness of the burst makes it difficult for the enemy to locate the transmitter while the addition of crypto devices reduces the probability that the messages will be interpreted by him. The short transmission burst also helps to clear the airways so that more traffic can be handled with fewer frequencies, and the one-way-at-a-time nature of the communication eliminates the temptation to get into a conversation.

The fact that a received message can be viewed and reviewed by the receiving party minimizes the confusion factor but does not completely eliminate it. This is because certain types of data are not immediately amenable to verbal description. When it comes to describing the position and movement of friendly or enemy forces to be taken (or not taken) to reach an objective, angles of attack to be attempted, or terrain features to be avoided, a picture is probably worth 10,000 words.

This fact has long been recognized and is manifested in the use of planning boards and maps at the higher echelons and scratchings in dirt or sketches on scraps of paper on the front lines. Where this type of graphic communication is required, all concerned parties must gather in one place to review and develop the plan, while messengers are used to carry the "word" to the responsible action parties. In the process, vital time and messengers may be lost in the communication.

INTERACTIVE COMPUTER PRESENTATION PANEL (ICPP)

The development of the Interactive Computer Presentation Panel (ICPP) will soon automate and computerize the planning board. Using computers and a dynamic large flat panel display integrated with a paper map, the ICPP will permit commanders to graphically view the tactical situation in real time, plan strategy and tactics based on current developments, and communicate the resultant picture to other ICPPs. Use of the Conference Mode will, in time, permit joint planning to take place by several commanders, each located in his own area of control but able to engage in multiway graphic conversation with other commanders.

The ICPP presents the dynamic battle situation under control of a host computer and an integrated controller. The 1 meter by 1 meter panel shows such data elements as enemy and friendly troop dispositions, No Fire Lines (NFL), and the Forward Edge of the Battle Area (FEBA). As the situation changes, the computer displays the updated locations. Integration with the paper map shows all positions relative to the specific areas of the map.



Using an Interactive Operator Control (IOC) unit, the operator may move forces around (in a planning mode) or ask for amplifying data about specific forces that are represented on the map by standard military symbols.

Symbols can be created, modified, moved, or grouped. System response time is measured in fractions of seconds with all data presented in

clear, easily-understood formats. For example, in the case of the Litton ICPP, enemy forces are shown in red; friendlies in green; and the FEBA, and NFL, in amber.

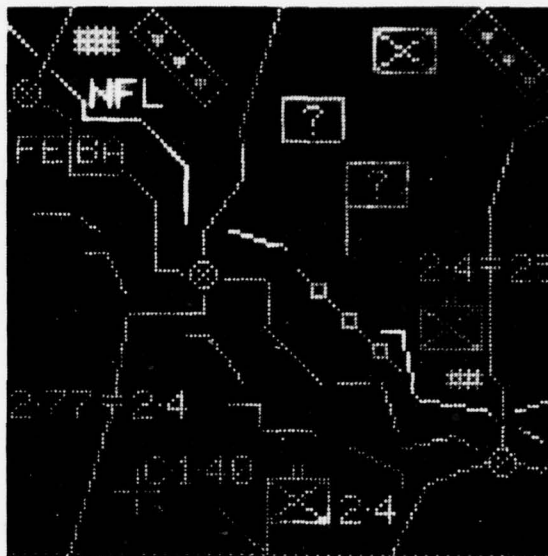

The instantaneous graphic representation of the current battle situation allows the commander to make immediate, intelligent decisions without the need for overlays or other mechanical aids that have, up until now, tended to delay and, at times, completely impeded the planning process.

While the ICPP will solve the graphic representation and communication problem for the commander, it will do little to help the lower echelon personnel who can hardly be expected to carry an ICPP into a forward observation post, forward air control post, or attack aircraft; and the idea of an infantry platoon leader carrying into battle anything but the smallest of communication devices borders on the ludicrous.

Yet, the information that might be made available on a graphic communication device could be invaluable. Answers to questions like, "What is my position relative to yours?" or "... the next platoon?" or "... Company B?" or "... the enemy?" or "... our objective?" can be given most clearly and succinctly in a graphic form.

INTERACTIVE DISPLAY TERMINAL (IDT)

With the development of the Interactive Display Terminal (IDT), it is now possible to compose, edit, transmit, receive, and display graphic messages using a unit that is less than 100 cubic inches in volume and weighs less than four pounds, including batteries. Its 3" x 4½" LED display and infinitely variable keyboard combine

to provide a capability and flexibility that have previously not been available, even in larger, more complex devices. Display resolution on maps, charts, or graphs is approximately 1% so that, for example, each diode position on a 2 km x 2 km map displayed on the IDT represents 20 meters.



While the map display area on the IDT is small, it can represent an appropriate area of interest and a useful resolution for a forward observer, company commander, or survey party, when a 2 km or 4 km square area is shown; or for a forward air controller or Stinger or Redeye Missile team, when a 16 km square area is shown. Changes in scale on the display may be achieved by requesting transmission of various size areas of interest from a higher echelon or by scaling an indicated area within the IDT itself.

Map-related data such as location of friendly and enemy forces, NFLs, safety zones, that are transmitted to and displayed on the IDT, are merely subsets of the identical data appearing on the ICPP. Terrain reference points: e.g., roads, rivers, hilltops, buildings, bridges, which normally appear on the map overlay of the ICPP also must be digitized and transmitted to the IDT for use by forward element forces.

INTERACTIVE GRAPHIC TERMINAL (IGT)

The ability to capture and transmit this type of data has been developed as part of the IDT system. The mechanism uses a digitizer connected to an IDT. This combination is referred to as the Interactive Graphic Terminal, IGT. As the user of the digitizer traces the map terrain features with the stylus of the digitizer, the lines which are drawn, immediately appear on the map display area of the IGT according to the map scale previously selected. Symbology such as buildings, bridges, hilltops, etc. may be added to

the map to within 1% of their true locations by using the symbol keyboard of the IDT in conjunction with the digitizer. When the map is completed, it can be transmitted instantaneously to other IDTs.

HOW GRAPHICS WILL BE USED

A typical sequence of events might involve a Forward Observer (FO) establishing an observation post and transmitting a message to the battery commander defining his location, the direction he is facing, in mils, and the map area he wishes to view. Using a specially designed template, the operator at the IGT selects the appropriately scaled paper map, orients the digitizer to the direction indicated by the FO, selects the proper scale, registers a corner of the map area and, using the digitizer stylus, traces the appropriate terrain features and enters selected symbology including the location of friendly and enemy forces. The IGT operator then transmits the map to the requesting FO's IDT. (As the troops move, updates are sent; and map symbols are moved.)

The received map, not only displays the area of interest, with a 1% resolution, it displays it at the orientation requested by the FO. The entire process, from initial request through map generation and transmission to receipt, takes only 3-5 minutes.

By using the functions within the unit, the FO or other forward element can now: 1) move a cursor to any point on the map; 2) enter symbology; 3) draw lines; 4) calculate distance and angle from one point to another; 5) request identification or amplifying data; 6) calculate the coordinates of a point; 7) change map scale; and 8) transmit, receive, and display any of the above information to another IDT, to a larger display, or to a computer. Included with this capability is the ability to designate a target and target type directly on the map, and transmit the resultant fire request so that the target coordinates enter the TACFIRE computer, Battery computer, or Fire Control Calculator directly while the receiving IDT displays the target at its map location. The aforementioned computers will calculate fire commands, while the commander will make his decisions on when or whether to fire based on his graphic display.

This latter function: i.e., that of displaying the location of the target on the map for the decision maker, represents the key element in the use of graphics in a tactical environment. By using various size graphic displays at different echelons, from the ICPP at Corps, Division, and Battalion to the IDT by the FO, Platoon Leader, Company Commander, or Air Defense Weapons team,

and making use of the same basic data base, all forces in the field will have the ability to see an up-to-the-minute picture of the area of the battlefield of interest to him. His position relative to others will be instantly presented in a clear, easy to comprehend form. Graphic communication will include:

- Battalion Infantry Commanders defining an objective to be taken
- Company Commanders sending attack plans up for approval and then transmitting approved plans (frag orders) to platoon leaders
- Forward Air Control Posts assigning aircraft for close air support while defining directions of approach and safety zones
- Artillery FOs pointing out targets and having the target location and type appear in graphic form for instant decision making
- *And many more.*

In all cases, each element will be able to see his position relative to other friendlies, the enemy, the target, and various terrain features. The possibilities for improved decision making and the resultant savings of lives is difficult to estimate, but we are sure it will be more than worth the investment in this new technology.

BIOGRAPHY

The author has had 23 years of experience in the design of information systems and is a co-inventor of the Interactive Display Terminal (IDT).



NEW TECHNOLOGY PROGRAMMABLE INTERFACE
FOR ARTADS AUTOMATIC TEST

By:

D. M. Priestley

One of the limitations to efficient application of automatic test systems has been the interface between the tester and the units-under-test (UUT). Whenever a test system serves a variety of different UUT's, there has been, in the past, a proliferation of special adapter cables and test-adapter boxes. The interface hardware makes the unique interconnections to the UUT and augments the test system with special loads and interface circuits. The procurement, logistics support and change control of such adapters for fielded UUT's becomes very cumbersome and a major expense to the user

A Programmable Interface Unit, introduced in the AN/USM-410 Automatic Test System, is a viable solution to the interface problem. The AN/USM-410 with programmable interface was first used by the Army during OT III support of the ARTADS AN/TSQ-73. Automatic test programs were developed for test and fault isolation of printed circuit boards. The flexibility of the programmable interface simplified the interface adapters required for test of the AN/TSQ-73 at Homestead Air Force Base during the June-December 1976 OT III tests.

The AN/USM-410 with Programmable Interface Unit shown in Figure 1 provides a complement of 128 identical Universal Test Point circuits, each of which can, under program control, be connected to a UUT interface line for measurement purposes or for excitation from a selected dc, ac, or pulse stimulus. The number of Universal Test Points that can be provided in a given

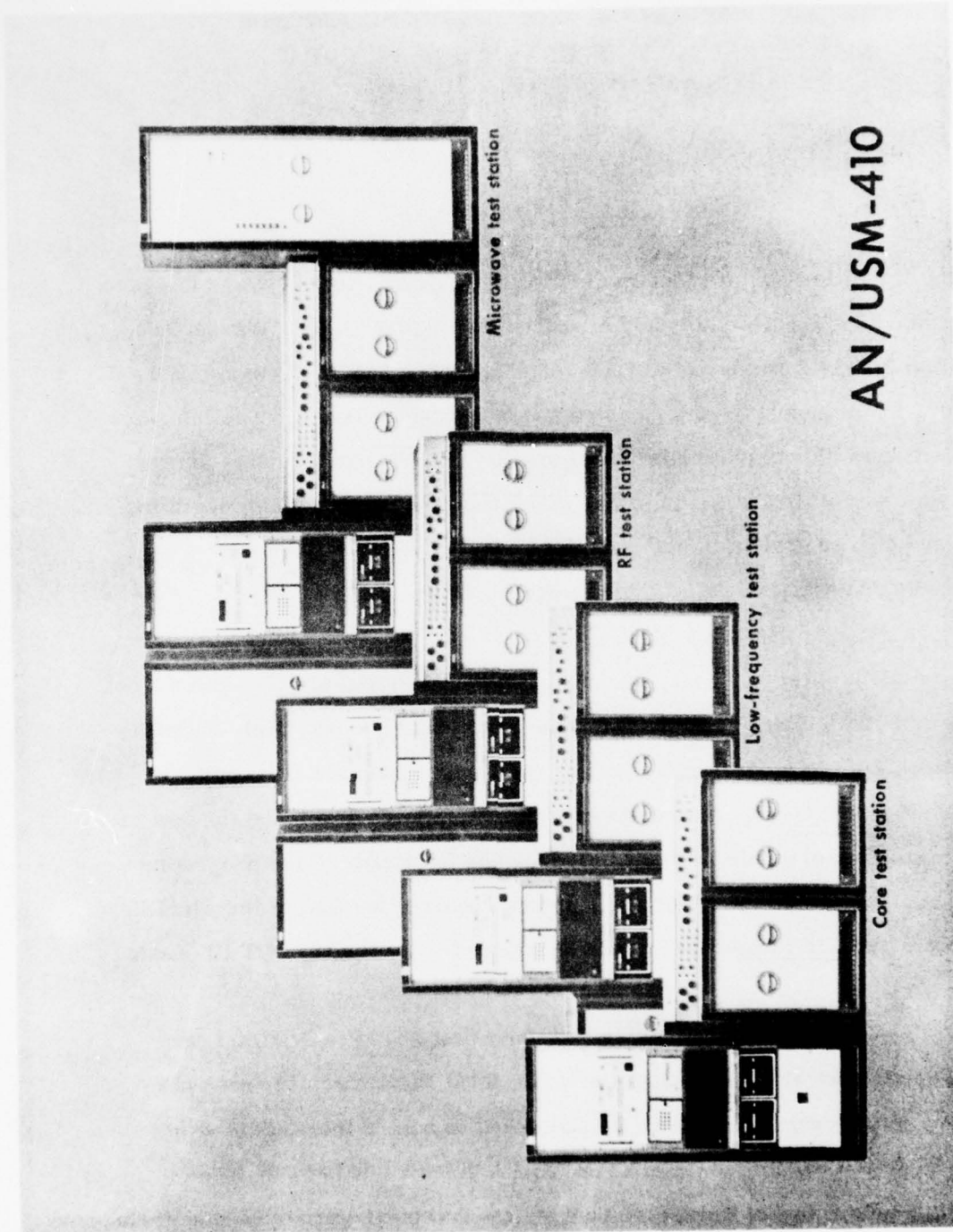

AN/USM-410

Figure 1. AN/USM-410

system is flexible because of the modular construction of the unit. Figure 2 shows one of the sixty-four Dual Universal Test Point boards of the Programmable Interface Unit. The individual hybrid microcircuits used on this board are separately highlighted in the photograph around the periphery of the board.

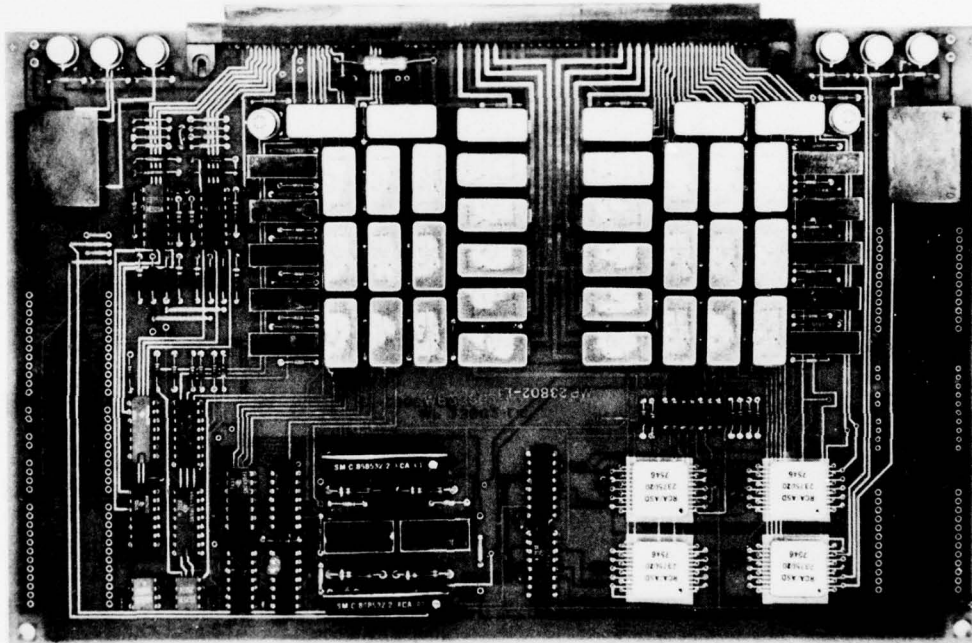

Figure 2. Dual Universal Test Point Board and Hybrids

Conventional discrete-circuit packaging methods would lead to a physically large unit that would be subject to system noise problems and performance degradation from line capacitance and resistance. The designers were motivated, therefore, to use hybrids to reduce the physical size of the unit to

manageable levels. Cost/performance trade-off studies revealed the desirability of converting three circuits of the universal test point to hybrid package configurations. They are:

- (1) 8-Channel, Latching Relay Driver
- (2) Digital Stimulus Buffer
- (3) Measurements Buffer

The studies showed that the desired miniaturization of the hardware by using hybrid microcircuits could be realized without cost penalties, even in relatively low production quantities⁽¹⁾.

The Programmable Interface Unit (PIU) was configured as a set of universal test points, plus associated buffers and multiplexers to perform three basic tasks:

- Generate and/or route analog and digital stimulus to the appropriate UUT pin or pins.
- Condition and route analog and digital measured data from the appropriate UUT pin or pins to the ATE measurement subsystem.
- Apply programmable loads at the appropriate UUT pin or pins.

In addition, the PIU contains probes and discrete connectors for routing rf signals (above 10 MHz) and high current (above 2 A/pin) as required.

Universal test points concept is shown in block diagram form in Figure 3. Each universal test point is identical in design, and consists of a single printed-circuit card (see Figure 4). Hence, the overall design of the

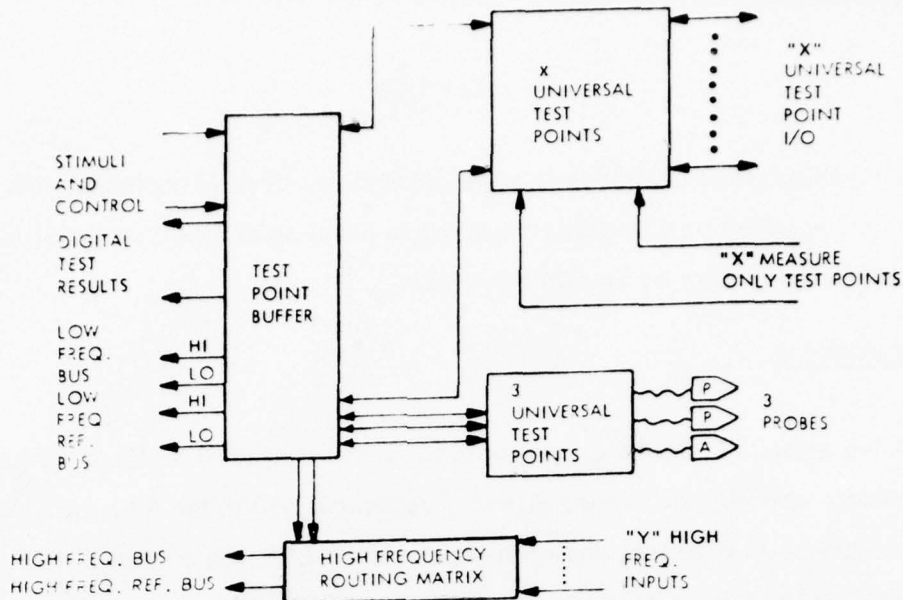

Figure 3. Programmable Interface Unit — a set of universal-test-point printed-circuit cards.

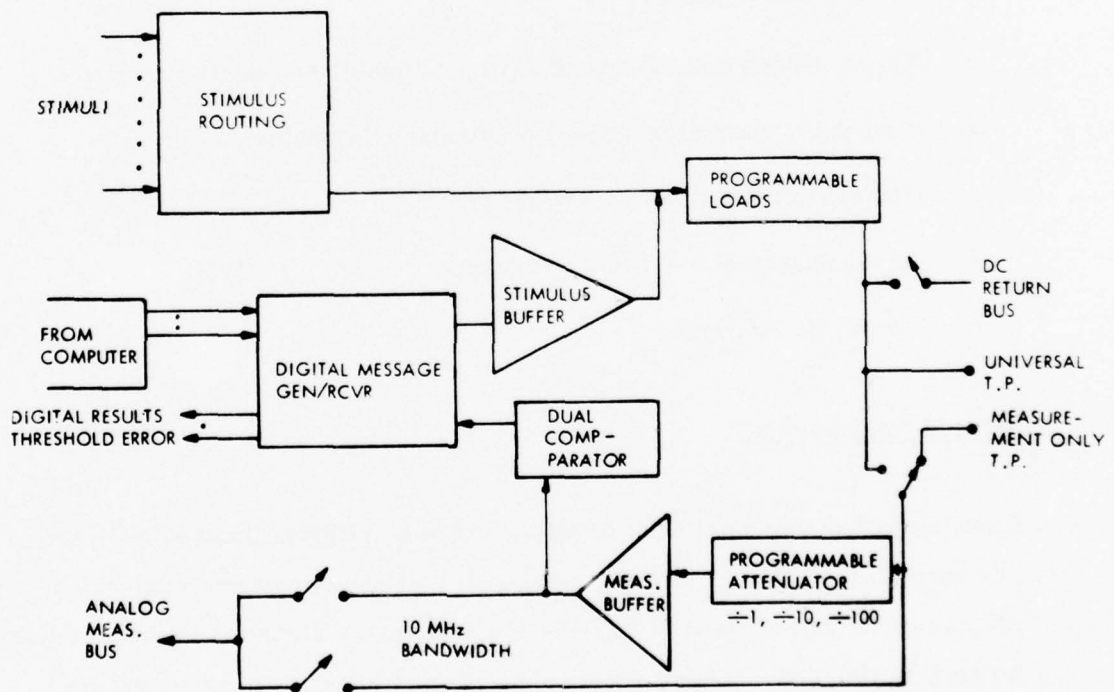

Figure 4. Universal test point. Each UTP consists of a relay matrix for stimulus routing, a one-bit slice of a digital message generator/receiver, programmable loads, measurement and stimulus buffers, and a dual voltage comparator (for threshold error detection).

Programmable Interface Unit is flexible, in that numbers of universal test points may be added or deleted as required in order to create ATE systems capable of testing large or small equipments.

Analog Stimulus

For analog stimulus, the Programmable Interface Unit (PIU) acts as a routing mechanism, whereby the proper stimuli, generated within the ATE, are routed, either singly or in combinations to the appropriate UUT pin or pins. Based on past experience with the stimulus requirements of hybrid (analog and digital) UUT's as well as on the capabilities of the ATE system, the following analog stimulus buses are routed to all UTP's:

- Five separately programmable dc stimuli (both hi and lo brought out on separate buses).
- Three-phases and neutral of a programmable ac power supply.
- Two-pulse generator stimuli (main and delay pulse).
- One arbitrary waveform generator.
- Three phases of a synchro generator.
- One ac/dc standard.

Analog Measurements

All analog measurements below 10 MHz, and at amplitudes up to $\pm 200V$, are made through the PIU. A measurement buffer/attenuator on each universal-test-point card will be used to buffer and condition the signal as required before routing it to the measurement subsystem. Each test point is connected via a set of relay multiplexers to any of four measurement buses, as illustrated in Figure 5. MUX "A" consists of four separate 16-to-1 relay trees, and

services up to sixteen universal test points (UTPs). There are four "B" MUX's, each a 16-to-1 relay tree, which multiplex the outputs of all "A" MUXs onto the four measurement buses. Hence, the output of UTP K can be programmably routed to BUS #1, UTP K + N to BUS #2, UTP K + M to BUS #3, etc.

Digital Stimulus/Response

The concept of a Programmable Interface Unit consisting of a number of identical UTP's presents a unique opportunity to eliminate a discrete digital message generator/receiver. Instead, one slice of the message generator/receiver is placed on each UTP board. This provides an optimum configuration for noise immunity, crosstalk, and skew. Figure 6 illustrates a typical digital test setup, utilizing three UTP's.

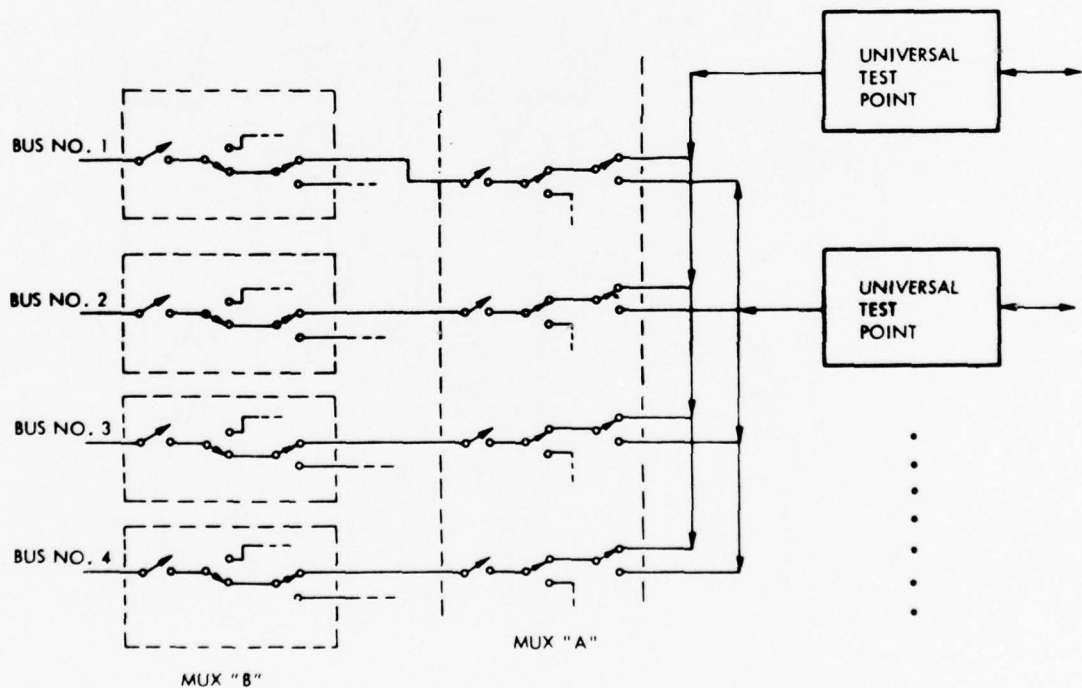

Figure 5. Analog measurement routine with the Programmable Interface Unit.

Digital responses are routed to the computer for evaluation, using a set of 16-to-1 digital multiplexers. In addition, threshold error detection is utilized on each UTP board, and a flag set upon detection. These flags may be examined by the computer, using the same digital multiplexers.

The stimulus buffer is capable of buffering all digital and clock outputs from the 256-bit shift register used as the digital message generator and receiver. This buffer consists of a programmable level shifter, covering the range from -6 to +6 Vdc, with a slew rate of 250 V/ μ s, or covering the range from -30 to +30 Vdc, with a slew rate of 100 V/ μ s.

As a source of sink, the stimulus buffer is capable of up to 100-mA operation. Using the programmable voltage level V_H and V_L , the stimulus buffer is capable of generating logic levels from -6 to +6 Vdc in steps of less than 5 mV, or -30 to +30 Vdc in steps of less than 25 mV. As a source of digital stimuli, the buffer is capable of transmitting data at rates greater than 10 MHz.

The measurement buffer is capable of handling input signals of up to ± 150 V in amplitude. The circuit consists of switchable attenuators ($\div 1/\div 10/\div 100$) feeding a very high speed (slew rate 1500 V/ μ s), high-input-impedance unity-gain buffer. Overall loading is greater than 1 megohm, with less than 80-pF capacitance. Bandwidth of this buffer is greater than 10 MHz. As shown in Figure 4, it is possible to programmably bypass the measurement buffer whenever unbuffered measurements must be made.

The output of the measurement buffer may be programmably routed to the shift register when receiving digital data. Before reaching the shift register, however, it is first passed through a dual voltage comparator, whose upper

and lower voltage limits are controlled by the V_{\min} "1" and V_{\max} "0" voltages. Thus, it is impossible to check high and low logic voltage levels in steps of:

1 mV to \pm 1 Vdc	50 mV to \pm 50 Vdc
5 mV to \pm 5 Vdc	100 mV to \pm 100 Vdc
10 mV to \pm 10 Vdc	500 mV to \pm 500 Vdc

The 236-bit shift-register chip forms a single slice of an n-bit digital message generator/receiver distributed over all n UPT's. This device performs the following functions:

- (1) Output a static parallel signal which, in conjunction with other UTP's, could mean a static parallel output word of up to n bits.
- (2) Output a clock parallel signal, clocked by either the main pulse, delayed pulse, or external clock, at rates of up to 10 MHz.
- (3) Output a serial stream of up to n bits, either as a burst or continuously recirculated, at a data rate greater than 2.5 MHz, clocked by the main pulse, delayed pulse, or external clock.
- (4) Input a parallel signal, either static or clocked at up to 10-MHz rate.
- (5) Input a serial stream of up to n bits, clocked by either the main pulse, delayed pulse or external clock, at rates of over 2.5 MHz.

Finally, it should be noted that the switching configuration of the UTP is ideally suited for self-test and calibration, since any of the stimulus outputs can be routed to the measurement inputs without the need for any external connections.

Programmable Loads

In addition to its stimulus and measurement capabilities, the Programmable Interface Unit contains the capability of applying a programmable load resistor at any UUT pin, using one or more UTP's. To accomplish this, each UTP board contains five resistors, which permit any one of 31 resistance values to be connected, either in series or shunt at the pin. A shunt-to-dc return (up to 5 A) or open circuit is also possible. Unused stimulus buses may be assigned as common buses to achieve even more versatility.

Test Probes

Three probes are available for use by the test operator; these can be connected to UTP's so that the probes themselves become programmable in function. They may accept ac or dc voltages to 200 V, analog waveforms to 10 MHz for frequency or time-interval measurements, or digital data to 10 MHz. In addition, they provide all of the stimulus capabilities of the UTP, so that signals may be injected as well as measured at internal test points. Note that with two probes, dual-channel time-interval measurements, as well as stimulus/response testing, are possible. The third probe is an active device, used when making extremely low voltage measurements (down to 100 μ V). This provides the capability of amplifying such low-level signals prior to introducing them into the ATE routing environment.

Acknowledgement

Much of the material describing the programmable interface was derived from material prepared by N.B. Wamsley of RCA.

References

1. Trade-Off Considerations in Contrasting Hybrid Applications - B. T. Joyce paper presented at ECOM Hybrid Microcircuits Symposium, 8-9 June 1976.



COMMAND & CONTROL SYSTEM APPLICATIONS
USING DEMAND-ASSIGNED-MULTIPLE-ACCESS
TECHNIQUES

Donald W. Horner
Motorola Government Electronics Division

At Motorola GED in Scottsdale, we are engaged in a TRI TAC sponsored Navy contract to develop a Demand Assigned Multiple Access (DAMA) System. Intended principally, for use with UHF satellite Relays such as Gapfiller and eventually FLTSATCOM the system could also have terrestrial applications.

The primary function of UHF-DAMA is to increase the throughput of a 25 KHz satellite-relayed channel to its theoretical/practical limit. This increase in throughput is obtained by a time-division-multiple-access (TDMA) technique wherein low to medium data rate users are provided store and forward burst access to the channel with very little guard time and overhead. TDMA efficiency is measured by subtracting guard and overhead time from the theoretical capacity of the channel and dividing the result by the theoretical capacity. DAMA efficiency is 80 per cent for the satellite system but has a potential maximum of over 90 per cent in terrestrial application such as the mobile subscriber access subsystem. We have reviewed the architectural requirements for this subsystem and they appear to be in overall consonance with our approach in UHF DAMA.

DAMA is much more than a TDMA system in its present application. It also provides for link or channel management. UHF

DAMA is a four phase program which is in Phase One. (See Figure 1) In the first phase, Motorola will develop the TDMA functions and provide a manually operated Channel Control Order Wire (CCOW) and Return Channel Control Order Wire (RCCOW) which will be utilized by the Navy for manual channel management. Also in Phase One, Motorola is to develop the preliminary design of an Automatic DAMA system which will fully automate the channel control functions. Since it is the automatic DAMA system which has terrestrial applications, we will concentrate on that system.

The Automatic DAMA (which will be backwards compatible with manual DAMA hardware) will be a micro-processor based system at the subscriber location and a mini-computer at the control site. The subscriber unit DAMA will be capable of handling four I/O channels arranged for half-duplex operation or two I/O channels which can be connected in full duplex if a full duplex radio is connected (DAMA has an IF interface to the receiver/transmitter.) The baseband ports can operate at data rates of 75,300, 600,1200,2400,4800, or 16,000 BPS. TDMA burst rates are 2400 and 9600 symbols/sec biphase modulated and 16, 19.2 and 32K bits/second quadrature. (See Figure 2 for Design Considerations.)

Information bits are uncoded or half or three quarter rate encoded (Viterbi Algorithm). The encoded bits are then randomly interleaved in blocks of 224 bits.

The coding and interleaving were both specific Navy SATCOM requirements generated by the need to communicate in severe RFI environment aboard

larger ships which utilize P-Band air search radars. Codes are set up for one (own ship or adjacent ship RFI) or two (own ship plus adjacent ship RFI) interfering pulses. IF pulse blanking was incorporated in the modem to avoid/to reduce pulse stretching.

All RF channels assigned to DAMA contain a command-signaling slot and request-signaling slot which are repeated each frame. These slots are utilized in the Automatic DAMA for system timing, COMSEC control, System Control, call requests and subscriber status. Each signaling slot operates at 75BPS baseband bursting at 9600BPS rate. Both are protected by external COMSEC devices. The control slot transmits a message which spans eight TDMA frames while the request message is structured to be transmitted in a single slot.

By using the request slot, the DAMA subscriber is able to signal his request for a communications channel, the controller/alternate controller are able to execute control handover, and a net controller allowed to request new nets. There are eight distinct messages which can be sent on the RCCOW slots which, in the aggregate provides much more information than is normally available at a wire-line switch. The RCCOW can not only handle the three requests mentioned above but is also able to report in and/or request a link test (maintaining the unique characteristic of satellite communications which enables the sender to monitor his own signal on the downlink side), report results of his

link test (used by the controller in channel assignments), report the conditions he is experiencing locally, cancel a call previously requested and report relinquishment of a circuit.

In the control message, each of the request slots is assigned either to an individual user or to a precedence - level where random-access can take place. Assignments of users to a common TDMA slot, slot preemptions or preemptive warnings and new net establishments are provided in each frame. The first frame of the eight frames also provides system status in the form of precedence - level threshold and time-limits established for calls.

There is also signaling exchanged between the user and the subscriber unit. When the user goes off-hook, the subscriber unit will provide a dial-tone (or other "data-ready"indicator) to the user which invites him to insert his demand. The user then inserts the number of the party/net he wishes to call and the precedence of his call. The subscriber unit stores this information until the first available request slot at which time it transmits the signal inserting its own ID# and indicator that this is the first transmission of the request. At this time, the subscriber would be informed by an audio burst that the transmission had been sent. If the request slot selected were dedicated to that user or if no contention was encountered, the call is acknowledged by the controller to the subscriber unit in about 3 seconds. At this time, the subscriber unit would inform the user by another audio burst that the call had gotten through and the average "wait" time (in seconds) would be displayed on the user's instrument. If the wait time is excessive to the user's needs, he has the option of canceling the call or re-inserting his demand at a higher precedence level.

The Automatic DAMA has, at this point in the process, provided the user with more information than the wireline system does. However, there is more. If, for example, a precedence level threshold had been established by the control, the subscriber unit would have provided an immediate busy signal to the user equivalent to a "trunk busy" signal. If the called party is engaged in an equal or higher precedence call a user-busy signal will be provided to the user. If both parties are assignable but the system is so busy that the call must be put in queue, a trunk delay audio burst is generated accompanied by the wait time (in minutes). Once again, the user can cancel or increase his precedence or wait for an automatic ring-back when the circuit becomes available.

There are several features in Motorola's UHF DAMA that are peculiar to the satellite applications (See Figure 3). For example, there is a TDMA slot which is used exclusively for users to measure their range to the satellite. In a TDMA system, a timing reference of some sort is necessary and in a satellite relayed system, the round trip time of a signal can vary from about 240 to 280 milli-seconds depending on user location. The DAMA system will automatically transmit periodic (period in hours) ranging signals to establish a time reference at the control stations within ± 50 microseconds. Another satellite peculiarity also stems from the long round trip delay time. The satellite user must key his transmitter 240-280 milliseconds prior to the beginning of his assigned burst time and in the half-duplex user's case when he keys his transmitter, he cannot

receive. Motorola has developed a scheduling algorithm which avoids user transmission over the control slot.

These two features would not be required in the Mobile Subscriber Access system since timing due to range differences would be within ± 60 microseconds (40KM relay) and hardware guardbands will be several orders of magnitude above that.

The TRI TAC Mobile Subscriber Access (MSA) subsystem, interfaces the wireline system of the TTC-39 and unit level switch with the mobile radio system. The MSA subsystem consists of the Mobile Subscriber Central (MSC), Mobile Subscriber Terminal (MST), including single channel radios and access units. We shall use MST and MSC to characterize DAMA. The MSC DAMA would act as a net manager for radio nets and would allow time sharing of the VHF nets for record traffic users and provide frequency agility for the various voice radio users which reduces their susceptibility to jamming.

The radio operates in the low portion of the VHF band and is a 25KHz channelized radio. Current usage envisions FM modulation using analog baseband. It would be relatively simple to provide a baseband and control interface which would allow for digital bi-ternary FSK modulation and frequency hopping.

In this interface, Motorola's DAMA would be much simpler than in the satellite application. DAMA would consist of the control micro-processor, the bi-ternary generator, a receive bit synchronizer input/output port logic and a DC/DC power supply.

The mobile subscriber application would also allow for much simpler frame formats. In the satellite mode, there are 6 baseband rates (all 75×2^n) and

5 burst rates (2.4, 9.6, 19.2, 16 and 32KBPS) plus 2 code rates (3/4 and 1/2) both with interleaving. The MSA DAMA could use one burst rate (19.2 KBPS) and has a sufficiently high C/N_0 so that coding and lower speed burst rates provide no noticeable error-rate improvement. A 19.2 KBPS burst rate will fit into a 25KHz channel using the bi-ternary FSK (formerly duo-binary) modulation format which reduces FSK bandwidth requirements by a factor of 2. 19.2KBPS also has the following advantages: it is a 75×2^n rate thus I/O port timing and buffering is simplified for low and medium data rate users. At the same time, it will accommodate the 16KBPS voice (DSVT) or DNVT user and still leave 3.2 KBPS for requests and channel control information.

In the MST application, the hardware guard band allowance could be allocated as follows:

- 1.5ms = frequency change
- 1.5ms = power up
- 1.9ms = signal acquisition

Adding the range and clock differential of 120 microseconds and 180 microseconds respectively (assuming a 10^{-6} /sec clock capable of free running for 3 minutes) the total guard time appears to be about 5.2 milliseconds or 100 bit counts at 19,200 bits per second.

Deleting the two satellite application time slots from our present format and increasing the control and request slot lengths to 200 bits each, to allow for slightly more data, the basic overhead of the MST DAMA is 600 bits out of 19,200 or a frame efficiency of 96.35%. The effect of the 5.2 millisecond guard time between any two users is to decrease the overall efficiency by another factor we could call slot efficiency. For the 75 BPS user, slot efficiency

(throughput divided by throughput plus guard) is only 42.8% and if the entire 25KHz channel were to be filled by 75BPS users, the overall efficiency would be 41.2%. (See Figure 4) if one 16KBPS, one 2.4KBPS and one 75BPS user were allocated slots on the same channel, then the overall efficiency would be 96.2% for that channel. (See Table 1)

The DAMA control microprocessor has storage for 512 frame formats. This means that we could construct tables containing 512 permutations of the MST 7 baseband rates which is a reasonable set of those possible. The frame formats stored tells the microprocessor in each DAMA what baseband rate is associated with what burst time marker, and when, in the 19,200 bit counter progression, those bits should be burst.

The concept of operation for MST DAMA would follow closely that of the UHF DAMA. The user would signal his request (in the clear or encrypted) to the Mobile Subscriber Central DAMA which would respond with an acknowledgement followed by an assignment. In this assignment message, a new message would be added which would refer to a frequency-hop pattern telling both net participants which frequency to use for which frame number and both transmitter and receiver would hop together. The pattern could be generated in a random manner which would make the system highly resistant to an intelligent jammer.

The precedence threshold, ring-back, user signaling and other attractive features of UHF DAMA would remain as fundamental features of MST DAMA.

The interface with the unit-level switch could be via the Access Unit operator who would be rung by DAMA and connected to the user who would

verbally provide the wire-line number he wished to reach and his precedence. The operator/user interface would be "red analog". At the point of electrical connection, the TTC-39 COMSEC System would set both the users COMSEC equipment to a common key and then allow communications. Eventually, this interface could be unattended with the wireline switch/DAMA exchanging in-band signaling. Even initially the operator need not become involved in the net-radio to net-radio interface as this would be handled by DAMA.

MST DAMA would be able to handle either secure TTY Nets or store-and-forward data from the mobile radio teletype terminals. The DAMA input/output port buffers have the capability of accepting data at the baseband rate, storing the data until the TDMA slot assigned is reached, and bursting it out to fill the assignment. At the distant end, the burst is received and loaded into the buffer at the burst rate and then clocked out to the user at the baseband rate. The UHF DAMA interfaces are all MIL-STD-188-100 low level.

Summary. In this paper, we have presented a review of the capabilities projected for the TRI TAC sponsored, Navy developed UHF DAMA Automatic Satellite Communications System. This system, capable of increasing the number of subscribers to a 25KHz satellite channel by a factor (proportional to user baseband rate and burst rate mix) up to 80 percent of the theoretical capacity of the channel, will have very sophisticated features. These same features with very little modification could be provided in the terrestrial, Mobile Subscriber Access Subsystem, with the addition of frequency hopping and the unit level switch inter-

face. Such an application would provide Tactical Communications with sophisticated service at a very moderate cost.



DAMA PROGRAM PLAN

- PHASE I – A. DEVELOPMENT OF FULL SCALE ENGINEERING DEVELOPMENT MODELS OF THE UHF DAMA SYSTEM SUBSCRIBER UNIT**
- B. DEVELOP DESIGN PLAN AND SPECIFICATION FOR SYSTEM CONTROL UNIT**
- PHASE II – PRODUCTION OF UHF DAMA SUBSCRIBER UNITS**
- PHASE III – DEVELOPMENT OF FULL SCALE ENGINEERING DEVELOPMENT MODELS OF THE UHF DAMA SYSTEM CONTROL UNIT (AUTOMATIC SYSTEM CAPABILITIES)**
- PHASE IV – PRODUCTION OF UHF DAMA SYSTEM CONTROL UNITS**

FIGURE 1



DAMA SYSTEM DESIGN CONSIDERATIONS

ENVIRONMENTAL REQUIREMENTS	DESIGN FEATURE
• VARIABLE USER DATA RATES.....	SELECTABLE TIMESLOT WIDTH
• ERP AND G/T USER MIX.....	SELECTABLE LINK BURST RATE AND CODE RATE
• SEVERE RFI ENVIRONMENT.....	SELECTABLE ERROR CORRECTION DECODER RATES
• STRONG RADAR IN-BAND POWER LEVELS.....	PULSE BLANKING WITH BLANKING INFORMATION GIVEN TO DECODER
• WORK WITH EXISTING HARDWARE.....	MULTIPLE INTERFACE SELECTIVITY
OPERATIONAL REQUIREMENTS	
• MINIMIZE VOICE TURN AROUND DELAY TIME.....	FRAME FORMAT AND BUFFER MICROPROCESSOR DESIGN
• FRAME TO FRAME CHANNEL REASSIGNMENT.....	DEDICATED ORDER WIRE TIME SLOT
EVOLUTIONARY REQUIREMENT	
• EASY GROWTH FROM MANUAL TO AUTOMATIC CONTROL.....	MICROPROCESSOR IMPLEMENTATION

DAMA FRAME FORMATS (NON AIRCRAFT)

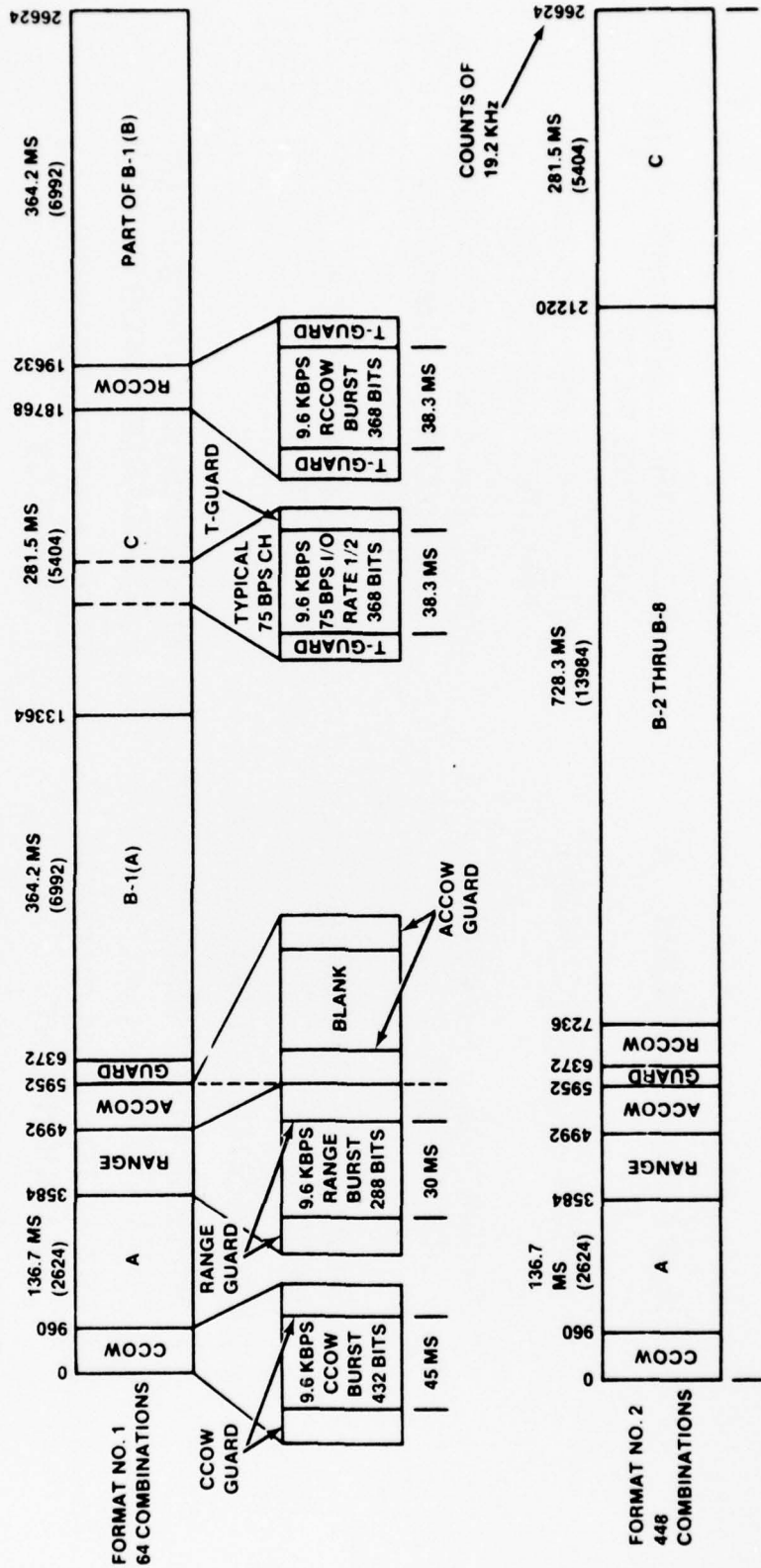
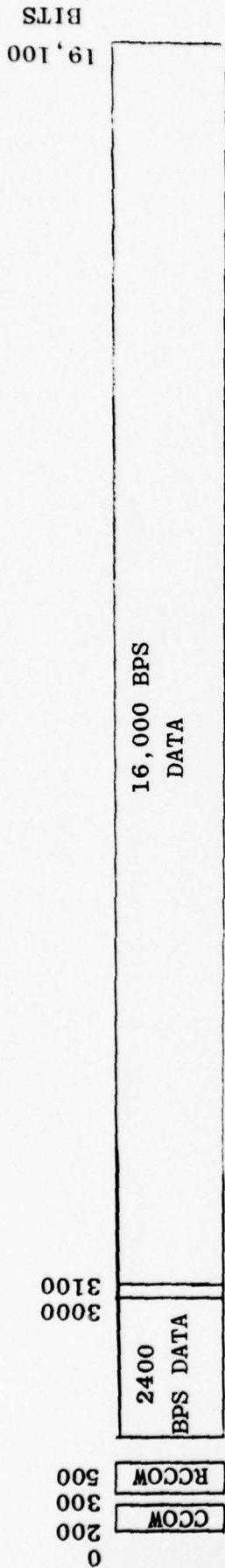
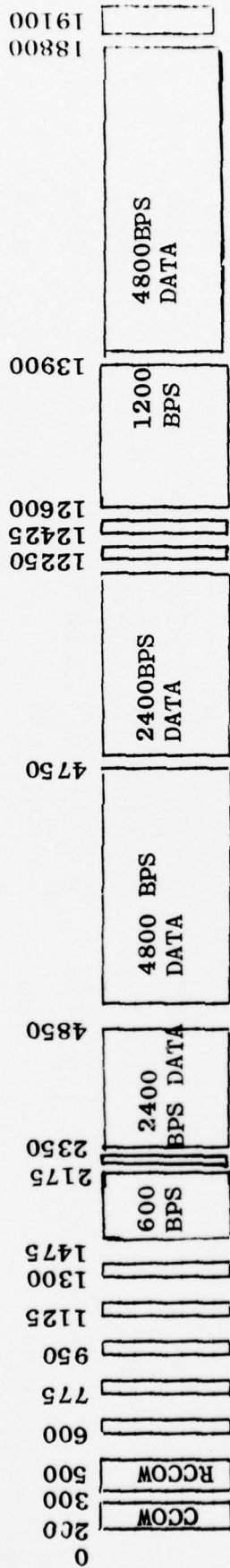

FIGURE 2



Example 1 Frame Format MSA DAMA
2 Subscriber Slots System Efficiency 95.8%



Example 2 Frame Format MSA DAMA
15 SUBSCRIBER SLOTS System Efficiency 89%

FIGURE 4
Two Examples of 512 Possible Combinations of Baseband Rates
Into MSA DAMA Time Slots

BURST RATE = 19,200 BITS/SECOND
 FRAME DURATION = ONE SECOND
 FRAME EFFICIENCY = $\frac{\text{CHANNEL CAPACITY} - (\text{CONTROL BITS} + \text{REQUEST BITS} + \text{GUARD})}{\text{CHANNEL CAPACITY}}$

$$= \frac{19,200 \text{ BITS} - (200 \text{ BITS} + 200 \text{ BITS} + 300 \text{ BITS})}{19,200}$$

$$= \frac{19,200 - 700}{19,200} = 96.35\%$$

SLOT EFFICIENCY = $\frac{\text{DATA BITS}}{\text{DATA BITS} + \text{GUARD}}$; GUARD = 100 BITS

<u>NUMBER OF USERS</u>	<u>DATA BITS/USER</u>	<u>SLOT EFFICIENCY</u>	<u>SYSTEM EFFICIENCY</u>
105	75	42.5%	41%
74	150	60%	57.8%
46	300	75	71.8
26*	600	85.7	81.3
14*	1200	92.3	87.5
7*	2400	96	95.3
3*	4800	97.9	96.8
1*	9600	98.9	94.1
1*	16000	99.4	95.8

*SYSTEM EFFICIENCY CALCULATED BY ADDING USERS AT LOWER DATA RATES TO FILL CAPACITY

TABLE ONE
USER EFFICIENCIES MSA DAMA (EXAMPLE)

TITLE

"COMMAND AND CONTROL SYSTEM APPLICATIONS USING DEMAND
ASSIGNED MULTIPLE ACCESS TECHNIQUES"

ABSTRACT

Efficient communication management is provided for geographically spread, diverse data users by time sharing transmission channels using a system currently under development by Motorola Inc., Scottsdale, Arizona, under a TRI TAC sponsored U.S. Navy contract. The technology being implemented is Demand Assigned Time Division Multiple Access.

(DAMA)

Demand Assignment automatically allocates channels as a function of user requests through in-band orderwire channels. Time Division Multiple Access allows efficient bandwidth/power utilization by providing simultaneous, on demand, access for many users over an available transmission channel. User equipment can be deployed on a wide range of mobile and fixed platforms, including jeeps, ships, and aircraft.

An overview of several DAMA System Applications for both line-of-sight and relay/satellite links is presented in this paper.

Biography of Author

Don Horner was born in New Jersey in 1932. He received a BA in Philosophy from St. Mary's University in 1953, a BS in Humanities and Electrical Engineering from M.I.T. in 1962, and an MS in Management Engineering from George Washington University in 1970.

Since June, 1977, he has been employed as a Principal Staff Engineer at Motorola Government Electronics Division, Scottsdale, Arizona, assigned to the UHF DAMA project as a Systems Engineer. His industry related experience includes Spread Spectrum Systems Engineering and Project Management. He retired from the U.S. Navy in 1974 after 20 years of service, the last seven of which were spent in Washington in Satellite Communications Systems Definition and Engineering and established the Naval Telecommunications Systems Engineering office in the Naval Electronics Systems Command.



ARCHITECTURAL IMPACT OF FIBER OPTICS ON FUTURE MILITARY SWITCHING SYSTEMS

Dr. Edmund A. Harrington
GTE Sylvania Inc.
Eastern Division
Needham Heights, Mass.

ABSTRACT

Significant advances in fiber optics technology have been made in industrial and DoD research laboratories during the past few years. The main impact to date has been in the realm of the transmission plant. However, it is expected that fiber optics will soon be entering the switching plant. This paper will address the problem of phasing in fiber optics into the design of military switching systems. Various fiber optics switching architectures will be assessed in terms of their present and future cost effectiveness.

1.0 INTRODUCTION

The future of fiber optics in military telecommunication networks is very promising. Of crucial military importance¹⁻⁵ is the fiber cable's resistance to EMP/lightning effects, the ability to reduce adjacent channel crosstalk below -95 dBm, reduction in weight and volume/unit bandwidth over metallic cable and finally the reduced number of repeaters required on long haul trunking links.

The principal disadvantages have been the cost of the fiber cable, the tactical survivability of the cable, and the inability of the fiber cable to transmit DC power. In the future, great progress is expected in these areas and more and more of the transmission plant should convert to fiber cable systems. This will certainly impact the switching plant.

As fiber transmission becomes more cost effective, the architecture of the whole telecommunications switching network will certainly be affected. This is examined in Section 2.0. The evolution of fiber optics across the transmission/switching interface is assessed in Section 3.0 and its eventual impact on the architecture of the switching matrix is examined in Section 4.0. Finally the future trends of fiber optics in telecommunication switching networks are discussed in Section 5.0.

2.0 IMPACT ON SWITCHING NETWORK ARCHITECTURE

Optical fiber transmission systems promise to yield very wideband telecommunication networks. Areas where access switching was used to conserve

transmission bandwidth may not be necessary in the future, since the cost of bandwidth should be greatly reduced. In addition, the cheaper bandwidth should also enhance the use of wideband digitized voice techniques. This is especially important to the military because of the communications security problem. Hence, wideband data distribution networks should increase in importance.

Optical fiber transmission systems should favor a common data bus network architecture. Telecommunications between subscriber terminals can take place over a common optical path with each terminal communicating to every other terminal, sending out information on a time shared basis.

There are currently two main configurations being considered for the optical distribution of data to a set of remote terminals. One is a serial distribution system employing access or T couplers, and the other is a parallel distribution system employing a star coupler. A block diagram of an N-terminal serial distribution system with T couplers is shown in Figure 1(a) and a similar block diagram for an N-terminal parallel system with a star coupler is shown in Figure 1(b). These configurations can supply non-blocking access between all subscribers without any switching nodes per se.

These configurations will prove cost effective for a limited number of subscribers. However, for a network with a large number of subscribers some form of optical switching will still probably be necessary to conserve the optical transmission bandwidth.

Also, as fiber optics penetrates the existing transmission plant, it must interoperate with the switching nodes currently in place. Hence, there will be a need either for some type of conversion at the transmission/switching interface or modification of the switching node to accommodate some form of direct optical switching.

3.0 IMPACT ON TRANSMISSION/SWITCHING INTERFACE - PHASE I

The initial impact of optical fiber transmission systems on switching nodes will be at the transmission/switching interface. Thus, the current terminal circuit will have to be modified to accommodate optical fibers. The terminal circuit will have to incorporate a fiber optic transmitter and receiver. As shown in Figure 2(a) the fiber optic transmitter/receiver in the terminal circuit will allow the switch to interface with the electrical baseboard signals of the transmission facility. The rest of the switching process can take place in the normal manner and only the terminal circuit is affected.

For the fiber optic transmitter one can choose from a variety developed for the transmission world. The choice of the transmitter should take into account the output power required, ease of modulation, long lifetime, low cost, and fiber compatibility. Three main kinds of optical transmitter sources have these general characteristics - semiconductor light emitting

diodes (LEDs), semiconductor injection lasers, and solid state lasers such as Nd:YAG. Presently, semiconductor injection lasers are the most promising in meeting all the desired characteristics.

Optical detection for the fiber optic receiver can be accomplished by using either p-i-n photodiodes or avalanche photodiodes (APD). Both photodetectors are well-developed technologies. Optical receivers using p-i-n photodiodes are usually thermal noise-limited. To increase the sensitivity, avalanche photodiodes that have internal amplification are used. High data rate reception using APD detectors is usually limited by signal shot noise or amplifier noise. The status of the optical receiver sensitivity is shown in Figure 3, where required power is plotted as a function of data rate for various front-end approaches⁶.

4.0 IMPACT ON SWITCHING MATRIX - PHASE II

Just as digital transmission has led to digital switching, so also optical fiber transmission should lead to cost effective optical switching (See Figure 2(b)). Direct optical switching of information on optical fibers will be implemented in the future through the use of integrated optics. Integrated optics treats that body of technology wherein guided wave structures including semiconductor lasers, optical waveguides, optical modulators and switches, diffractors, and couplers can be fabricated in various hybrid semiconductor structures.

Various laboratory optical switches/modulators have been implemented using electro-optic, acousto-optic, magneto-optic, and electro-absorption effects in bulk materials. The first three effects produce refractive index changes in response to the appropriately applied electric, acoustic, and magnetic fields. The last effect produces a change in optical absorption in response to an electric field.

Low crosstalk optical switches can be realized readily with thin-film integrated-optic structures. Several electro-optic crosspoint candidates, such as mode converters, Bragg gratings, and directional couplers, have been compared in a recent report⁷. Layout drawings are given for a low crosstalk matrix employing electrically controlled directional couplers as tandem crosspoints, and a matrix design including pairs of switchable gratings is also presented.

However, before these optical switches can be fully utilized in a truly optical data transfer network, they must be coupled to fiber transmission lines. A problem related to the polarization state of propagating waves arises when fibers and micro-optical devices are connected⁸. Since both polarizations are usually present in single mode fibers, and since micro-optical thin film devices usually process different polarizations with different efficiencies, the performance of micro-optical devices is expected to be significantly degraded when they are incorporated in a fiber optical data network. The

problem of fiber/micro-optical waveguide coupling is currently being researched at GTE Laboratories and elsewhere.

5.0 FUTURE TRENDS

In another five years or so one should see the prototype implementation of optical fiber telecommunication networks using optical repeaters and switches. Since optical fiber transmission links have already been installed in GTE's and ATT's commercial networks, systems with optical repeaters/switches can be regarded as the coming "second generation." Integrated optical components will enable the capabilities of the optical fiber as a telecommunications medium to be more fully utilized.

The full capabilities of fiber optic networks will be realized when the source signals are designed as an integral part of the network. For example, the TV camera converts optical images to electronic signals which are subsequently processed and transmitted. For first and second generation systems the electrical signals will be converted to optical signals before transmission. It is logical to consider the construction of a TV camera such as to form an optical image which is optically scanned and serialized. This optical signal would then be directly switched and multiplexed for transmission via fiber systems. As another example, speech may be converted directly to optical signals via acousto-optical transducers. Optical encryption techniques can then be used for transmission security. This type of system concept should alter the military telecommunication network economics in a fundamental way. The individual terminal units should be considerably cheaper due to the absence of the extra conversion to electrical signals. This fundamental attack on the subscriber equipment and its compatibility with the switching/transmission media may well result in a considerable reduction in the total network cost.

The evolution of optical instrument/switching/transmission systems to the third generation will be rather gradual. The optical fibers themselves will be required to transmit with low loss and low dispersion throughout the visible band; new optical sources will be required, and integrated optics will certainly be mandatory. This stage of military switching network evolution will be very much conditioned by the success of the first two stages. Fiber optics will certainly play a major role in all phases of the future evolution of military switching networks.

REFERENCES

1. R. A. Andrews, A. F. Milton, and T. G. Giallorenzi, "Military Applications of Fiber Optics and Integrated Optics," IEEE Trans. Microwave Theory and Tech., Vol. MTT-21, No. 12, pp. 763-769, December, 1973.
2. L. U. Dworkin, L. A. Coryell, and R. E. Dragoo, "The Application of Fiber Optics to Army Communications," ITC, pp. 251-262, 1975.
3. P. Steensma, T. Eppes, and J. Holland, "Optical Fiber Transmission in the TRI-TAC System" TRI-TAC Symposium, April, 1976.
4. G. H. Sigel, "Fiber Optics for Naval Applications: An Assessment of Present and Near-Term Capabilities," NRL Report No. 8062, September, 1976.
5. P. Steensma and M. Weinberg, "Optical Fiber Transmission--Realities and Ideals a Communication Architectural View," AFCEA Technical Seminar, June, 1977.
6. T. A. Eppes, J. E. Goell, and C. Kao, "Long Distance Optical Communication," Proc. Intern. Conf. on Communications, 1975.
7. R. A. Steinberg and T. G. Giallorenzi, "Performance Limitations Imposed on Optical Waveguide Switches and Modulators by Polarization," Applied Optics, Vol. 15, No. 10, pp. 2440-2453, October, 1976.

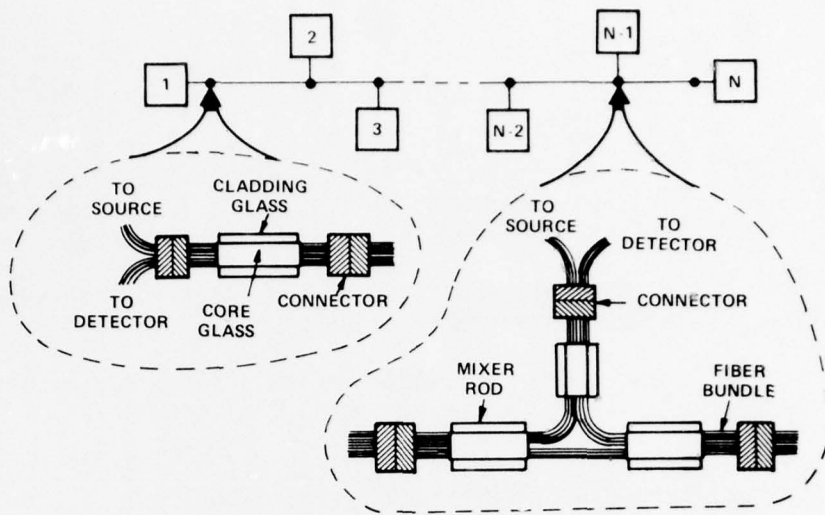

(a) OPTICAL T COUPLER DISTRIBUTION SYSTEM

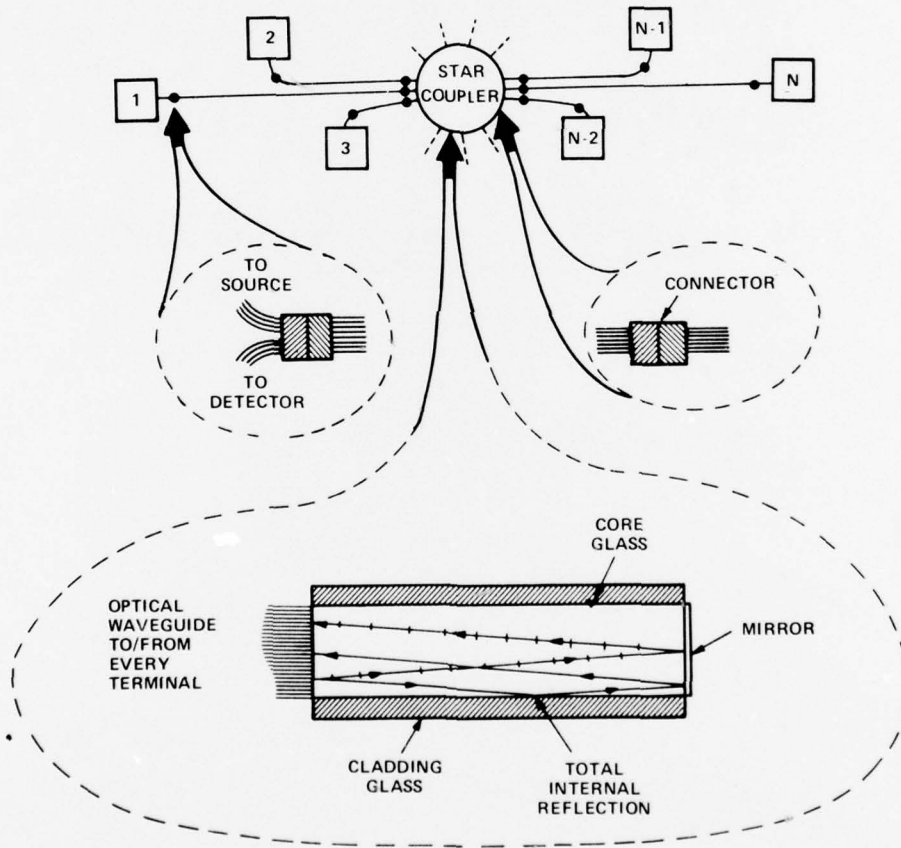

(b) OPTICAL STAR COUPLER DISTRIBUTION SYSTEM

4582-77E

Figure 1. Optical Fiber Distribution Systems.

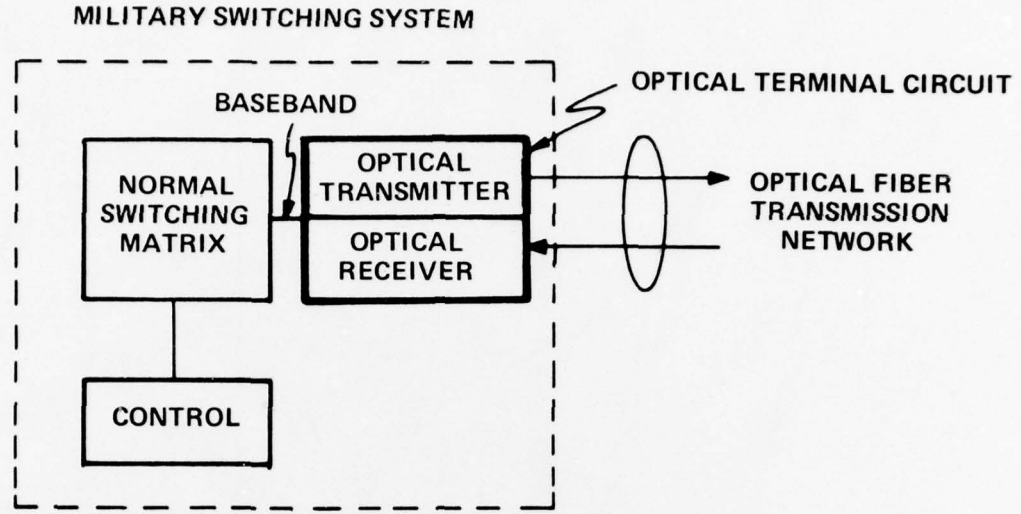

(a) TRANSMISSION/SWITCHING INTERFACE - PHASE I

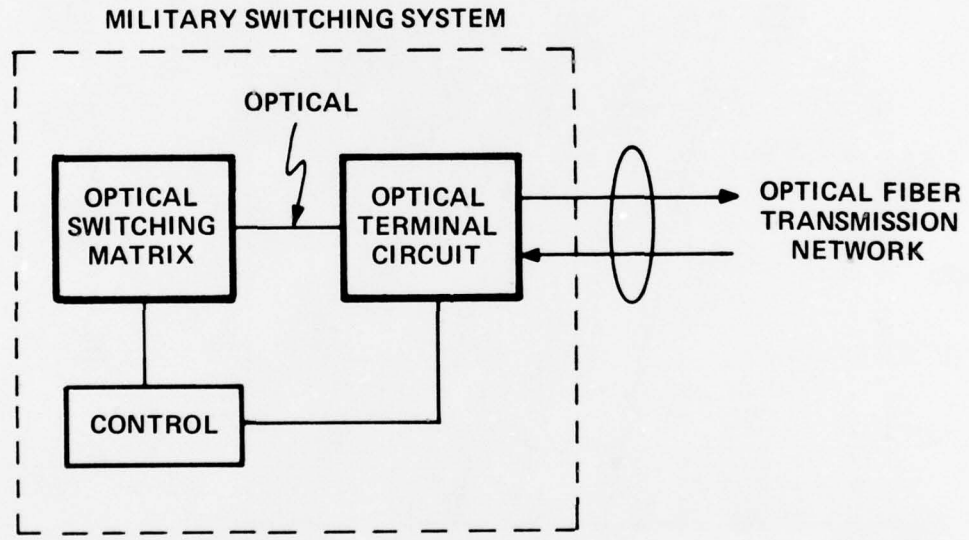

(b) SWITCHING MATRIX - PHASE II

4581-77E

Figure 2. Impact of Fiber Optics on Switching Architecture.

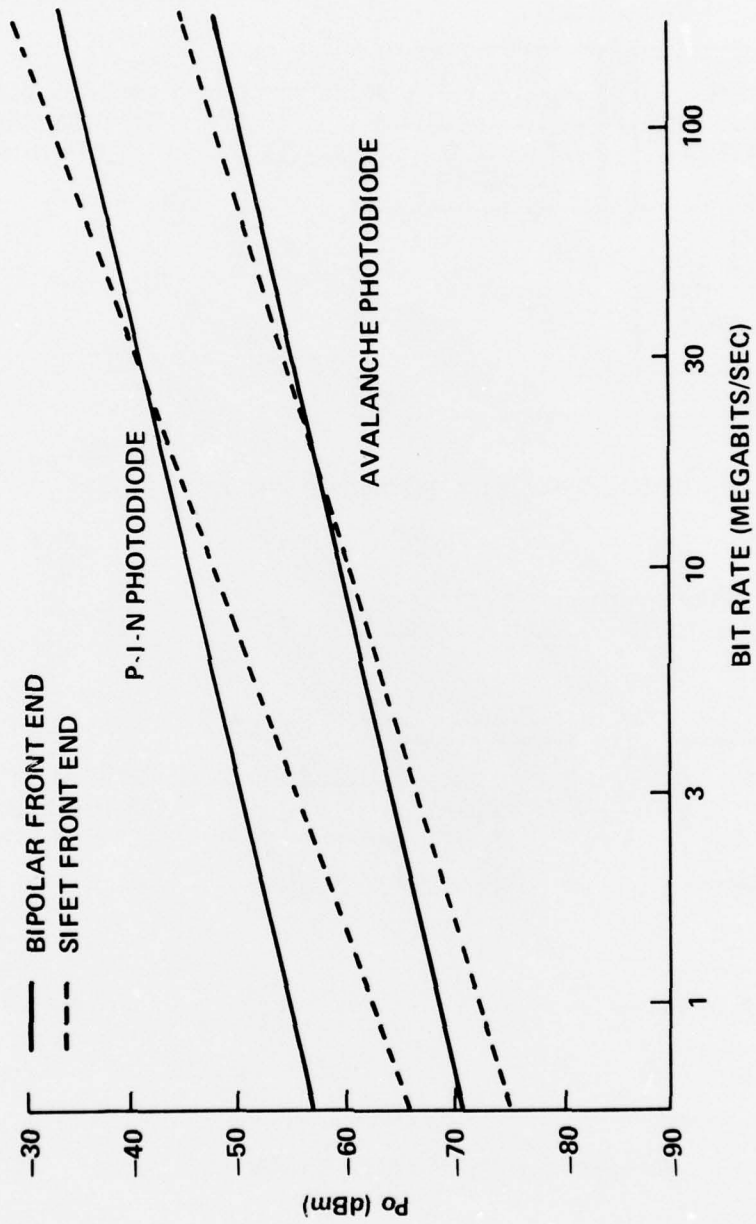

REQUIRED POWER VERSUS BIT RATE FOR PCM AT 10^{-8} BER

4583-77E

Figure 3. Optical Receiver Sensitivity.

EDMUND A. HARRINGTON

GTE Sylvania--Eastern Division

Experience

Overall--Fiber Optics, Electronic Switching Systems, Computer Communications Telecommunication Networks.

Has over ten years experience in systems design and analysis.

As a graduate student worked on the systems analysis and design of high-speed, on-line, data acquisition and processing systems at Brookhaven and Argonne National Laboratories. Since joining GTE Sylvania in 1972, has been heavily involved with the development of the TRI-TAC and AUTOSEVOCOM II digital switching networks. While working on the AN/TTC-39 program, was responsible for the systems requirements and systems engineering for the TENLEY interface. Also participated in the TRI-TAC/AN/TTC-39 Fiber Optics Applications Study. Recently involved with the pre-proposal work for the Unit Level Circuit Switch (ULCS), AUTOSEVOCOM II Digital Access Exchange (DAX), and AUTOSEVOCOM II System Engineering and Technical Assistance (SETA) program.

Before joining GTE Sylvania, was employed by Bell Telephone Laboratories working on the system fault diagnosis and diagnostic software for the No. 1 and No. 1A ESS. He was also involved in the architectural development of Bell's No. 1A Control processor.

Has several publications in the areas of fault diagnosis of switching systems, applied probability and digital switching and synchronization techniques.

Education

BS, Physics, Providence College, 1965

Ph.D, Applied Physics, University of Notre Dame, 1970



