

AD-A044 420

PRATT AND WHITNEY AIRCRAFT GROUP WEST PALM BEACH FLA --ETC F/G 21/5
CUMULATIVE DAMAGE FRACTURE MECHANICS AT ELEVATED TEMPERATURES.(U)

APR 77 D L SIMS, C G ANNIS, R M WALLACE

F33615-75-C-5097

UNCLASSIFIED

FR-8101

AFML-TR-76-176

NL

1 OF 1
ADA
044420



END
DATE
FILMED
10-77
DDC



ADA 044420

AFML-TR-76-176 PART III

(Handwritten initials)

*PT 1038070
2041239*

CUMULATIVE DAMAGE FRACTURE MECHANICS AT ELEVATED TEMPERATURES

David L. Sims
Charles G. Anns, Jr.
Raymond M. Wallace

United Technologies Corporation
Pratt & Whitney Aircraft Group
Government Products Division
West Palm Beach, Florida 33402

DDC
RECEIVED
SEP 22 1977
RESOLVED
C

April 1977
Final Report for Period 1 May to 1 November 1976

Approved for Public Release; Distribution Unlimited

AU NO. _____
DDC FILE COPY

AIR FORCE MATERIALS LABORATORY
AIR FORCE WRIGHT AERONAUTICAL LABORATORIES
AIR FORCE SYSTEMS COMMAND
WRIGHT-PATTERSON AIR FORCE BASE, OHIO 45433

NOTICE

When Government drawings, specifications, or other data are used for any purpose other than in connection with a definitely related Government procurement operation, the United States Government thereby incurs no responsibility nor any obligation whatsoever; and the fact that the government may have formulated, furnished, or in any way supplied the said drawings, specifications, or other data, is not to be regarded by implication or otherwise as in any manner licensing the holder or any other person or corporation, or conveying any rights or permission to manufacture, use, or sell any patented invention that may in any way be related thereto.

This report has been reviewed by the Information Office (ASD/OIP) and is releasable to the National Technical Information Service (NTIS). At NTIS, it will be releasable to the general public, including foreign nations.

W. H. REIMANN
Project Engineer

FOR THE DIRECTOR

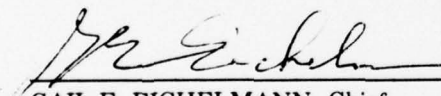
GAIL E. EICHELMANN, Chief,
Metals Behavior Branch
Metals & Ceramics Division

ACCESSION for	
NTIS	White Section <input checked="" type="checkbox"/>
DDC	Buff Section <input type="checkbox"/>
UNANNOUNCED	<input type="checkbox"/>
JUSTIFICATION	
BY	
DISTRIBUTION/AVAILABILITY CODES	
Dist.	1/ or SPECIAL
A	

Copies of this report should not be returned unless return is required by security considerations, contractual obligations, or notice on a specific document.

UNCLASSIFIED

SECURITY CLASSIFICATION OF THIS PAGE (When Data Entered)

REPORT DOCUMENTATION PAGE		READ INSTRUCTIONS BEFORE COMPLETING FORM
1. REPORT NUMBER 18 AFML-TR-76-176, P&WA	2. GOVT ACCESSION NO.	3. RECIPIENT'S CATALOG NUMBER
4. TITLE (and Subtitle) CUMULATIVE DAMAGE FRACTURE MECHANICS AT ELEVATED TEMPERATURES	5. TYPE OF REPORT & PERIOD COVERED FINAL rept. 1 May to 1 November 1976	
	6. PERFORMING ORG. REPORT NUMBER FR-8101	
7. AUTHOR(s) D. L. Sims, C. G. Annis, R. M. Wallace	8. CONTRACT OR GRANT NUMBER(s) F33615-75-C-5097	
9. PERFORMING ORGANIZATION NAME AND ADDRESS Pratt & Whitney Aircraft Group Government Products Division	10. PROGRAM ELEMENT, PROJECT, TASK AREA & WORK UNIT NUMBERS	
11. CONTROLLING OFFICE NAME AND ADDRESS Air Force Materials Laboratory Air Force Systems Command Wright-Patterson AFB, Ohio 45433	12. REPORT DATE April 1977	13. NUMBER OF PAGES 61 (12) 64 p.
14. MONITORING AGENCY NAME & ADDRESS (if different from Controlling Office) Air Force Materials Laboratory Air Force Systems Command Wright-Patterson AFB, Ohio 45433	15. SECURITY CLASS. (of this report) Unclassified	
	15a. DECLASSIFICATION/DOWNGRADING SCHEDULE	
16. DISTRIBUTION STATEMENT (of this Report) Approved for public release, distribution unlimited.		
17. DISTRIBUTION STATEMENT (of the abstract entered in Block 20, if different from Report)		
18. SUPPLEMENTARY NOTES		
19. KEY WORDS (Continue on reverse side if necessary and identify by block number) Fracture Mechanics, Crack Propagation, Life Prediction IN-100, Hyperbolic Sine, Interpolative Model, Cumulative Damage.		
20. ABSTRACT (Continue on reverse side if necessary and identify by block number) The interpolative hyperbolic sine model for mission-mix crack growth was used to predict the propagation histories and cycles-to-failure for two specimen geometries (compact tension and surface crack) at two temperatures (1000°F and 1200°F). Results were encouraging with an average prediction error of less than 15%.		

DDC
SEP 22 1977
RECEIVED
C

DD FORM 1 JAN 73 1473

EDITION OF 1 NOV 65 IS OBSOLETE

Unclassified

SECURITY CLASSIFICATION OF THIS PAGE (When Data Entered)

392887

FOREWORD

The major portion of this work was performed under Air Force Materials Laboratory Contract F33615-75-C-5097, "Application of Advanced Fracture Mechanics at Elevated Temperatures." Dr. W. H. Reimann is the project engineer. The program is being conducted in the Materials and Mechanics Laboratories, Pratt & Whitney Aircraft Group Government Products Division, West Palm Beach, Florida. Mr. M. C. VanWanderham, Manager, Mechanics of Materials and Structures, is program manager and Mr. R. M. Wallace, Group Leader, Component Life Analysis, is the principal investigator.

CONTENTS

<i>Section</i>		<i>Page</i>
	ILLUSTRATIONS.....	v
	TABLES.....	vii
I	INTRODUCTION.....	1
II	THE MODEL.....	3
	GENERAL MODEL.....	3
	EMPIRICAL SYNERGISTIC MODEL.....	
	3	
III	MODEL DEMONSTRATION.....	13
	LIFE ANALYSIS AT 1000°F.....	17
	LIFE ANALYSIS AT 1200°F.....	18
IV	CRITIQUE.....	33
V	CONCLUSIONS.....	38
	REFERENCES.....	39
	APPENDIX A — Life Analysis Computer Program User Instruction.....	40

ILLUSTRATIONS

<i>Figure</i>		<i>Page</i>
1	Effect of Frequency on SINH Model Coefficients C_2 and C_4	4
2	Effect of Stress Ratio, R , on SINH Model Coefficient, C_3	5
3	Effect of Temperature on SINH Model Coefficients (1000°F-1350°F, 10 cpm, $R = 0.1$).....	6
4	Effect of Frequency on Crack Growth in IN-100 $R = 0.1$, 1200°F.....	7
5	Effect of Stress Ratio on Crack Growth in IN-100, 10 cpm, 1200°F.....	8
6	Effect of Stress Ratio on Crack Growth in IN-100 20 cps, 1200°F.....	9
7	Effect of Temperature on Crack Growth in IN-100, 10 cpm, $R = 0.1$	10
8	Schematic Representation of the Method for Determining SINH Model Coefficients Representing Any Frequency, Stress Ratio, and Tem- perature.....	11
9	Incrementation of Simulated Turbine Disk Mission for 1200°F, Retardation Model.....	12
10	Surface Flaw Specimen.....	14
11	Modified Compact Tension Specimen.....	15
12	Simulated Turbine Disk Mission.....	16
13	Comparison of K-Calibration Curves for Surface Flaw Specimen.....	16
14	Incrementation of Simulated Turbine Disk Mission for 1000°F.....	17
15	Surface Flaw Specimen Crack Growth Prediction, Interpolative Hyperbolic Sine Model, No Synergistic Interaction, Linear Superposition.....	19
16	Modified Compact Tension Specimen Predicted Crack Growth, Interpolative Hyperbolic Sine Model, No Synergistic Interaction, Linear Super- position.....	20
17	Incrementation of Simulated Turbine Disk Mission for 1200°F, Linear Superposition.....	21
18	Surface Flaw Specimen Crack Growth Prediction, Interpolative Hyperbolic Sine Model, No Synergistic Interaction, Linear Superposition.....	22
19	Modified Compact Tension Specimen Predicted Crack Growth, Interpolative Hyperbolic Sine Model, No Synergistic Interaction, Linear Super- position.....	23
20	Effect of 25% and 50% Multiple Overloads on Sustained Load Crack Growth in IN-100, 1200°F.....	26

ILLUSTRATIONS (Continued)

<i>Figure</i>		<i>Page</i>
21	Surface Flaw Specimen Crack Growth Prediction, Interpolative Hyperbolic Sine Model, Retardation Model.....	28
22	Modified Compact Tension Specimen Predicted Crack Growth, Interpolative Hyperbolic Sine Model, Retardation Model.....	29
23	Modified Compact Tension Specimen Predicted Crack Growth, Interpolative Hyperbolic Sine Model, Retardation Model.....	30
24	Modified Compact Tension Specimen Predicted Crack Growth, Interpolative Hyperbolic Sine Model, No Synergistic Interaction, Linear Superposition.....	31
25	Comparison of 1000°F and 1200°F Linear Superposition Predictions With the 1200°F Retardation Prediction.....	32
26	Macrofractograph for 1000°F Surface Flaw Specimen.....	34
27	Macrofractograph for 1200°F Surface Flaw Specimen.....	35
28	Macrofractograph for 1000°F MCT Specimen.....	36
29	Macrofractograph for 1200°F MCT Specimen.....	37

TABLES

<i>Table</i>		<i>Page</i>
1	Mechanical Properties of Two IN-100 Pancake Forgings.....	2
2	Specimen 651 Surface Flaw Specimen 1000°F.....	21
3	Specimen 652 MCT Specimen 1000°F.....	21
4	Specimen 650 Surface Flaw Specimen 1200°F, Linear Superposition.....	24
5	Specimen 653 MCT Specimen 1200°F, Linear Superposition.....	24
6	Specimen 650 Surface Flaw Specimen 1200°F, Retardation.....	25
7	Specimen 653 MCT Specimen 1200°F, Retardation.....	25
8	Starting Stress Intensities.....	38
A-1	Namelist Variables.....	41

SUMMARY

This report provides a demonstration of an interpolative model for crack propagation life predictions at elevated temperature. The model is based on the hyperbolic sine. Two specimen geometries were tested under stress-temperature-time spectra that represent advanced gas turbine disk operating conditions. A critique of model predictive ability is presented.

SECTION I INTRODUCTION

Historically, the methods for predicting low-cycle fatigue (LCF) life have produced conservative underestimations of total useful life, resulting in costly early replacement of LCF limited gas turbine engine rotating components. Accurate total LCF life predictions must consider (1) the initiation of an actively propagating macrocrack, (2) fatigue crack propagation under constant maximum load, and (3) deviations in propagation behavior (acceleration and/or retardation) caused by major load excursions.

Engine hardware operates under complicated stress-time-temperature spectra, but laboratory testing must be done at selected conditions because of cost and time limitations. To describe crack propagation at conditions where test data does not exist, an interpolative crack propagation model is necessary.

This report presents a demonstration of an interpolative model for crack propagation behavior at elevated temperatures, which is based on the hyperbolic sine. Propagation life predictions using this model are made for two crack geometries tested under stress-temperature-time spectra representative of advanced gas turbine disk operating conditions.

All fracture mechanics evaluations were performed on an advanced nickel-base turbine disk alloy, GATORIZED™ IN-100, used in the F100 turbofan engine. Specimens specifically designated to this contract were machined from heat BANQ-499, but a significant amount of crack propagation data existed for this alloy prior to the start of this program and is also used in the analyses. Heat treatment consists of solutionization at 2050°F, stabilization at 1600°F and 1800°F, and precipitation hardening at 1200°F and 1400°F. Typical chemical composition is 0.07C-12.4Cr-18.5Co-3.2Mo-4.32Ti-4.98Al-0.78V-0.02B-0.06Zr - balance nickel.

Tensile, stress rupture, and creep test results for two forgings from this heat (499-A2A and 499-A2B) are given in Table 1.

TABLE 1. MECHANICAL PROPERTIES OF
TWO IN-100 PANCAKE FORGINGS

<i>Tensile Properties</i>					
<i>Disk No.</i>	<i>Temp (°F)</i>	<i>Yield Strength (ksi)</i>	<i>Ultimate Tensile Strength (ksi)</i>	<i>EL %</i>	<i>RA %</i>
499-A2A	RT	164.5	232.4	22.0	22.2
499-A2A	1300	157.2	177.0	14.0	22.3
499-A2B	RT	164.9	232.0	22.0	21.5
499-A2B	1300	156.0	179.1	14.7	16.4
<i>Stress Rupture Properties</i>					
<i>Disk No.</i>	<i>Temp (°F)</i>	<i>Stress (ksi)</i>	<i>Life (hr)</i>	<i>EL %</i>	<i>RA %</i>
499-A2A	1350	95	28.0	10.6	15.9
499-A2B	1350	95	18.0	8.1	15.6
499-A2B	1350	95	19.5	8.0	8.2
499-A2B	1350	95	19.3	6.7	12.9
<i>Creep Rupture Properties</i>					
<i>Disk No.</i>	<i>Temp (°F)</i>	<i>Stress (ksi)</i>	<i>0.1% (hr)</i>	<i>0.2% (hr)</i>	<i>Total Life (hr)</i>
499-A2A	1300	80	—	175.5	233.2*
499-A2B	1300	80	114.5	142.5	143.2*

*Test Discontinued.

SECTION II THE MODEL

An interpolative model has been developed for the analysis of elevated temperature fatigue crack propagation data. This model is used to describe the parametric effects of four fundamental influences on crack propagation: frequency (ν), stress ratio (R), temperature (T), and major load excursion effects.

GENERAL MODEL

This interpolative model is based on the hyperbolic sine equation,

$$\log (da/dN) = C_1 \sinh (C_2 (\log (\Delta K) + C_3)) + C_4 \quad (1)$$

where the coefficients are simple empirical functions of test frequency, stress ratio, and temperature:

$$\begin{aligned} C_1 &= \text{material constant} \\ C_2 &= f_2 (R, \nu, T) \\ C_3 &= f_3 (C_4, \nu, R) \\ C_4 &= f_4 (\nu, R, T) \end{aligned}$$

A more complete description of the model is presented in Reference 1. The salient features are given here.

It has been shown that for IN-100, the coefficients in equation 1 can be simple empirical functions of cyclic frequency, stress ratio, and temperature. Experience indicates that, for a given material, C_1 can be fixed without adversely affecting model flexibility. For IN-100, C_1 has a fixed value of 0.5. The coefficients C_2 and C_4 are logarithmic functions of cycle duration, $1/\nu$, (Figure 1) and C_3 exhibits linear variation with $\log (1-R)$ (Figure 2). The coefficients C_2 and C_4 are also linear functions of temperatures (Figure 3), from 1000°F to 1350°F. C_3 does not change with temperature because the correlation line is vertical. The relationships for frequency, stress ratio, and temperature are given in Figures 4, 5, 6, and 7.

The simple relationships previously discussed describe crack propagation of IN-100, at any stress ratio and frequency for temperatures between 1000°F to 1350°F in air conditions. The computational procedure is schematically represented in Figure 8. First locate the coefficients on the 1200°F, $R = 0.1$ frequency model, position 1. Second, account for stress ratio effects by moving along a stress ratio model to position 2. Finally, C_2 and C_4 for the desired temperature are determined using $\partial C/\partial T$ from the temperature model, position 3.

EMPIRICAL SYNERGISTIC MODEL

The majority of crack growth studies are performed using constant amplitude loading. These tests are not representative of gas turbine rotating component operating conditions, which include complex stress-time-temperature histories. It is expected that crack growth relationships will be complicated by mission mix cyclic conditions that result from throttle excursions, disk-blade interactions, etc.

A generalized predictive model must account for the effects of load sequence. A mission is first analyzed to determine if principles of linear superposition of damage were applicable. If they were not, then synergism must be considered. Since interaction effects are sensitive to the loading sequence, accurate crack propagation models can only be expected when realistic load-time histories are simulated (Reference 2).

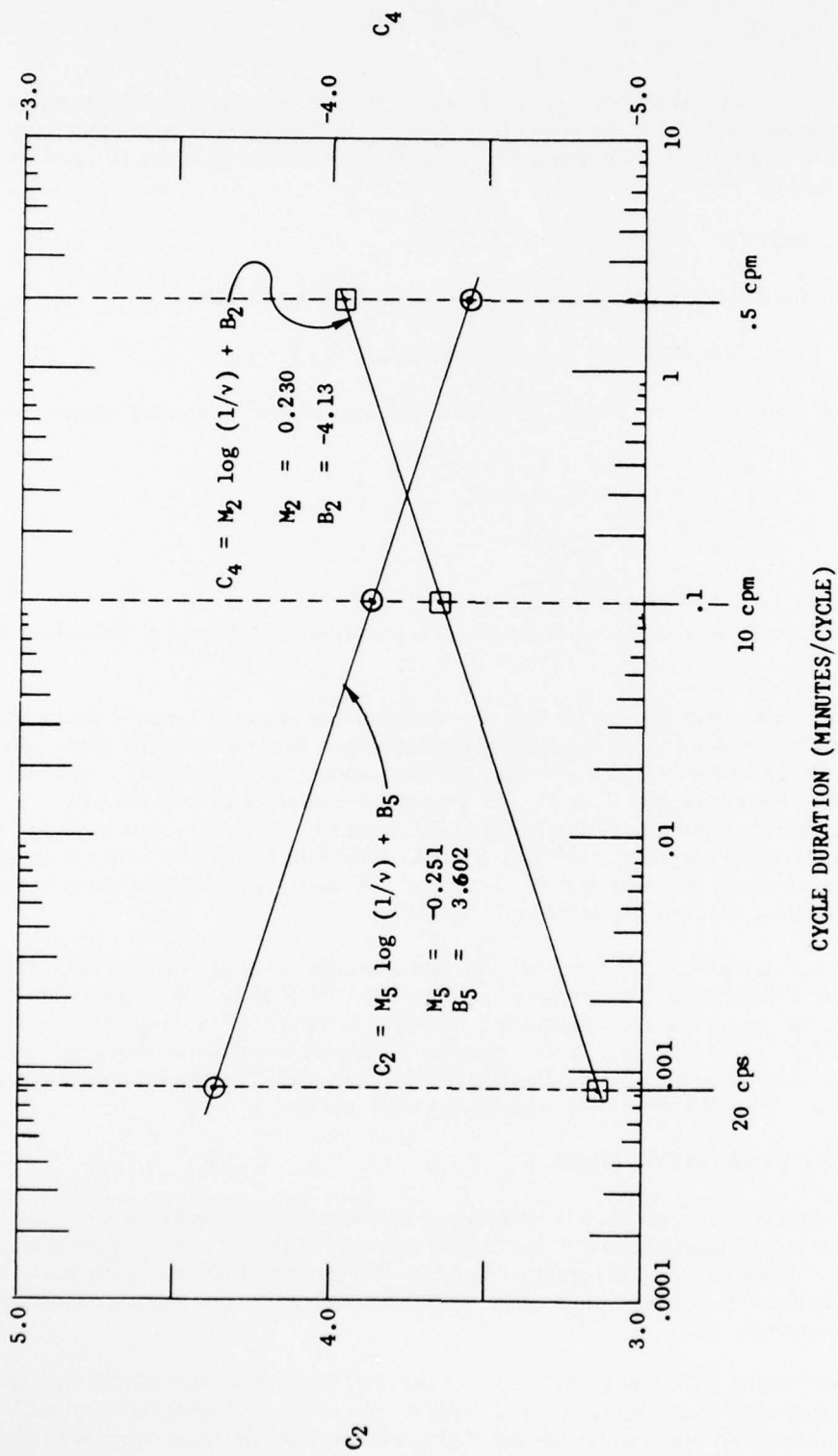

Figure 1. Effect of Frequency on SINH Model Coefficients C_2 and C_4

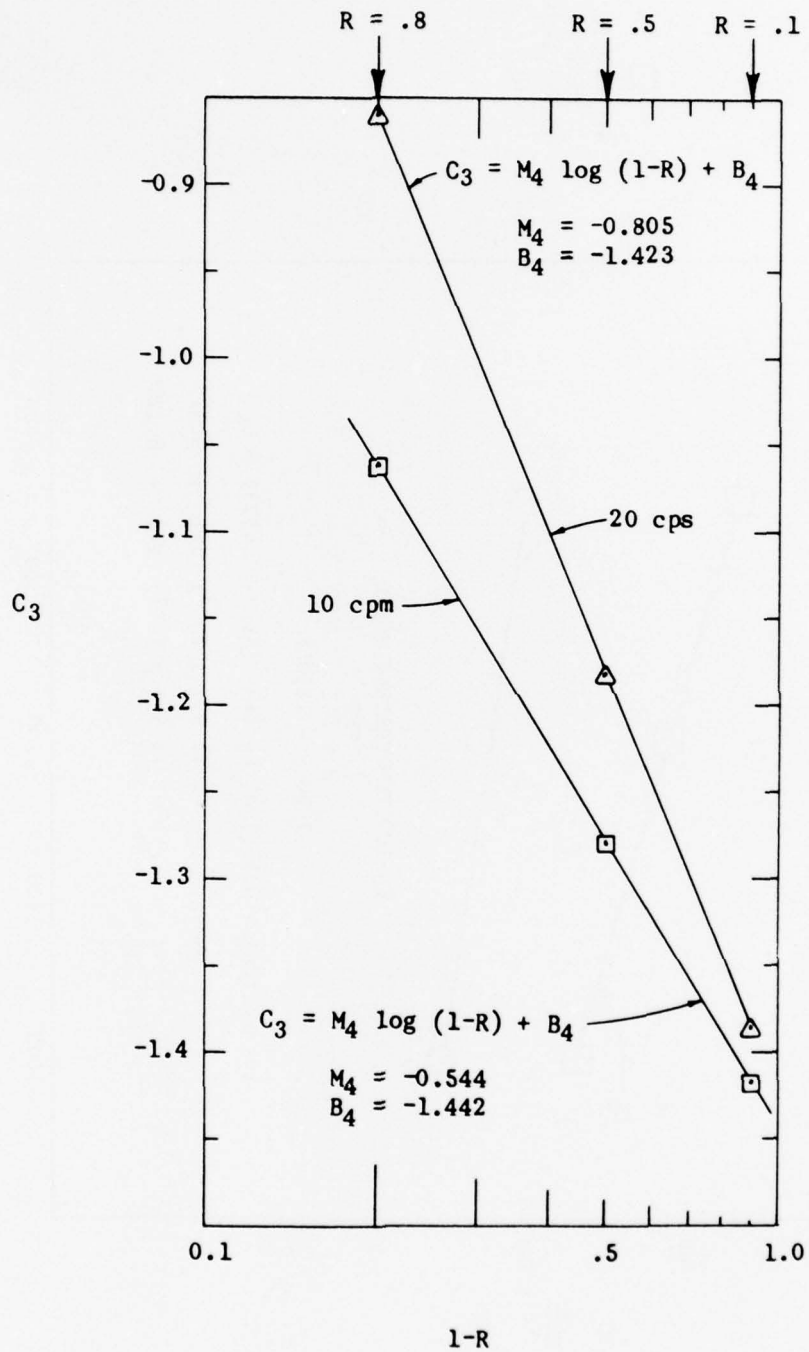

Figure 2. Effect of Stress Ratio, R , on SINH Model Coefficient, C_3

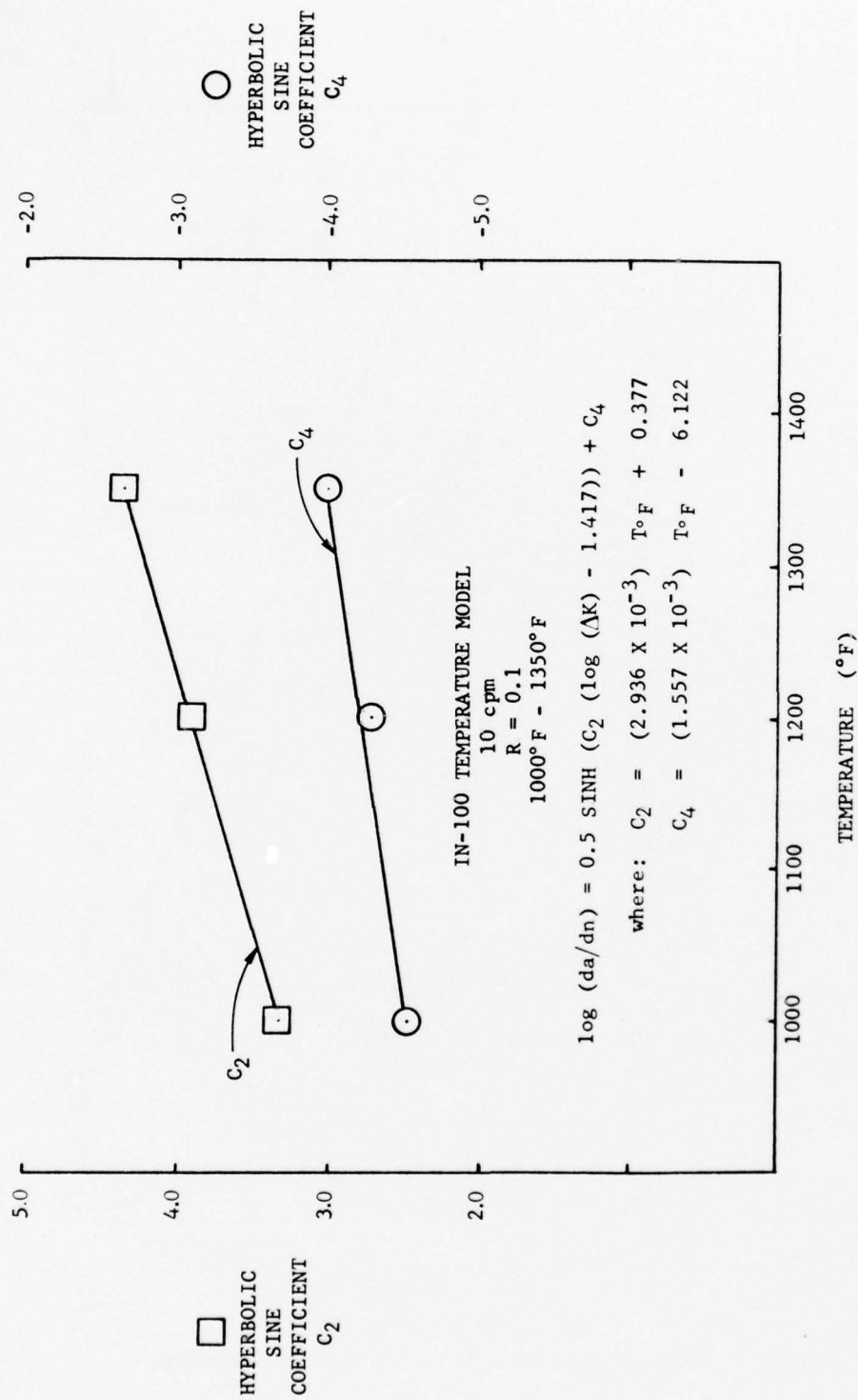

Figure 3. Effect of Temperature on SINH Model Coefficients (1000°F-1350°F, 10 cpm, $R = 0.1$)

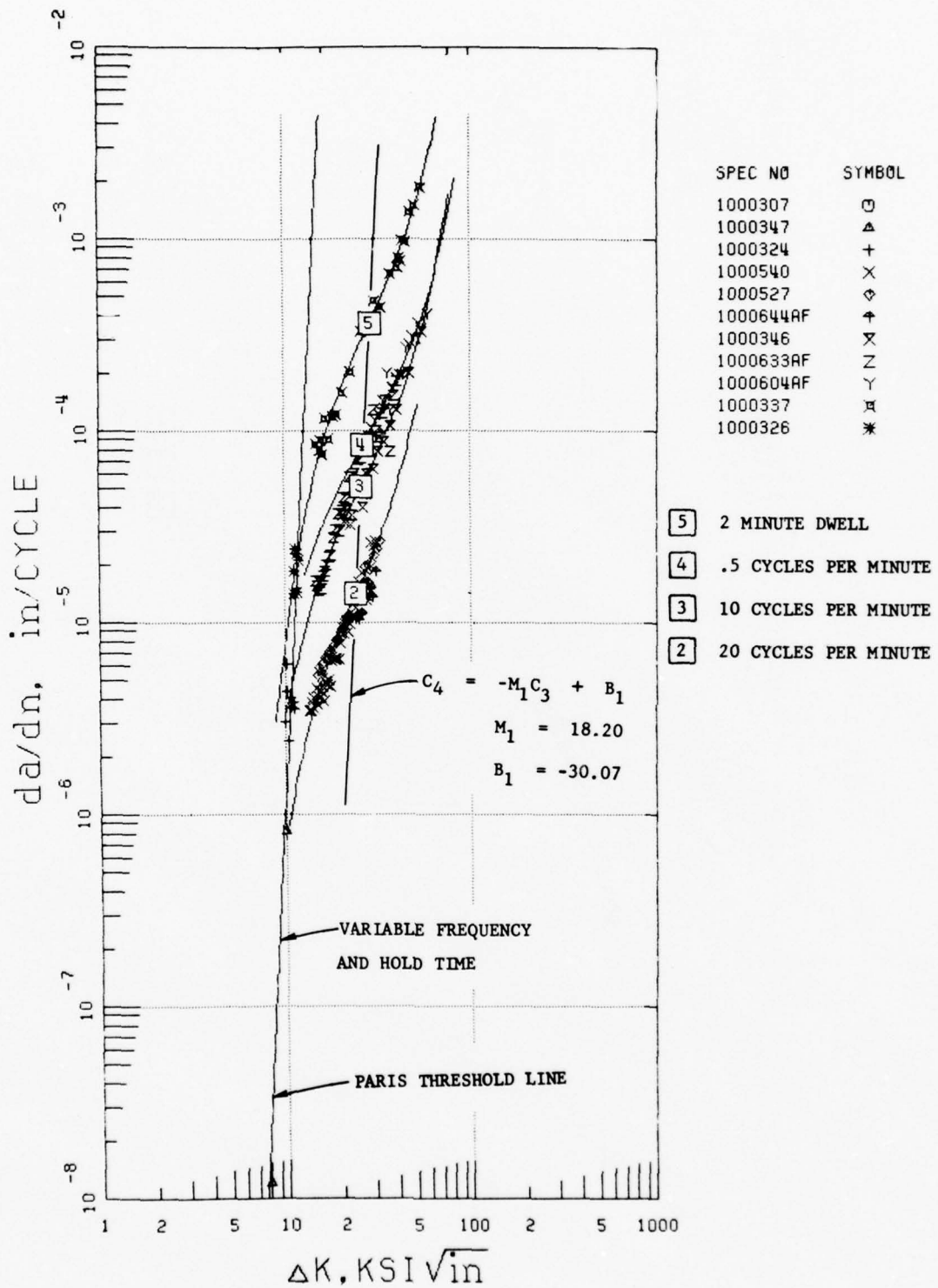

Figure 4. Effect of Frequency on Crack Growth in IN-100 R = 0.1, 1200°F

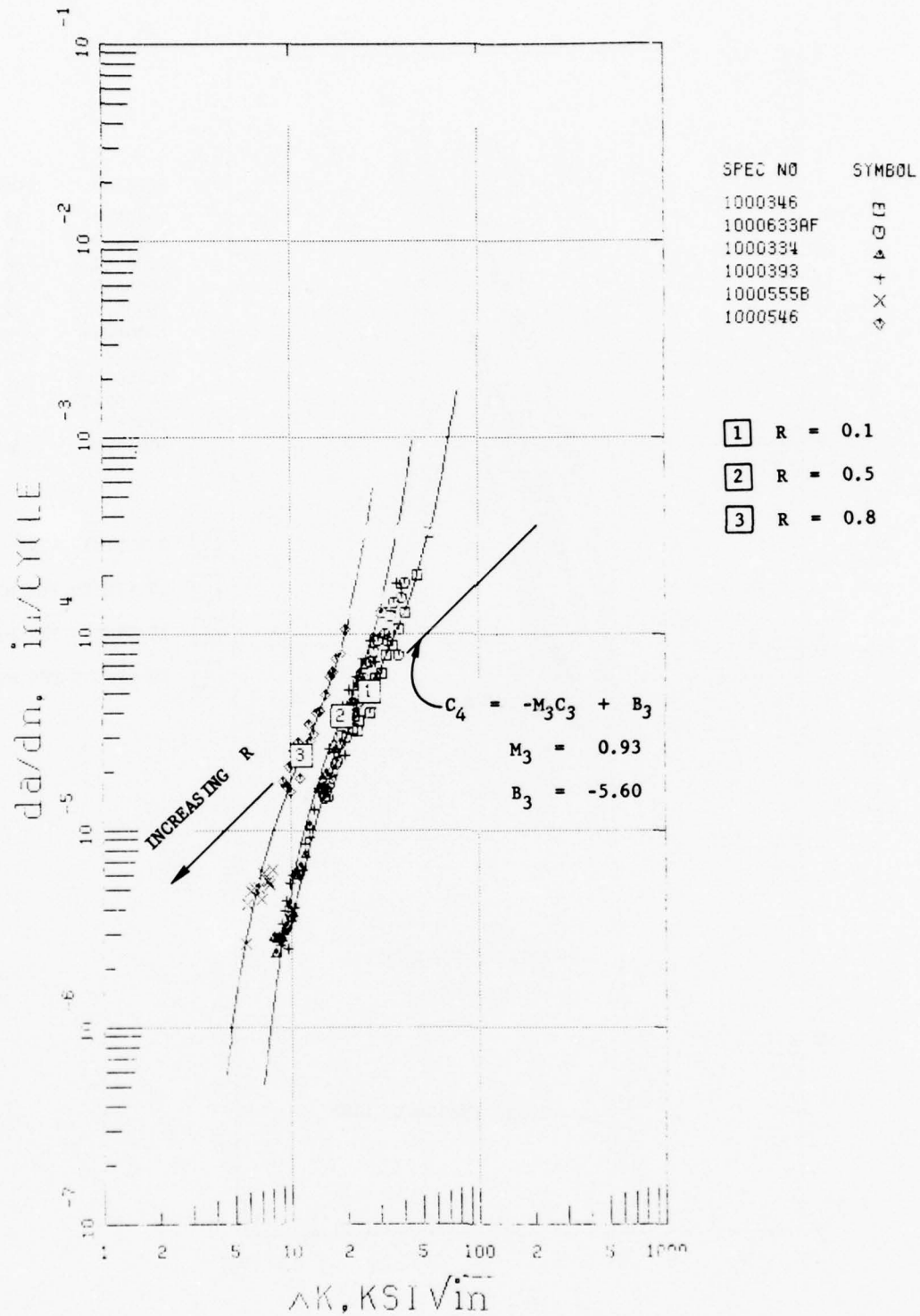

Figure 5. Effect of Stress Ratio on Crack Growth in IN-100, 10 cpm, 1200°F

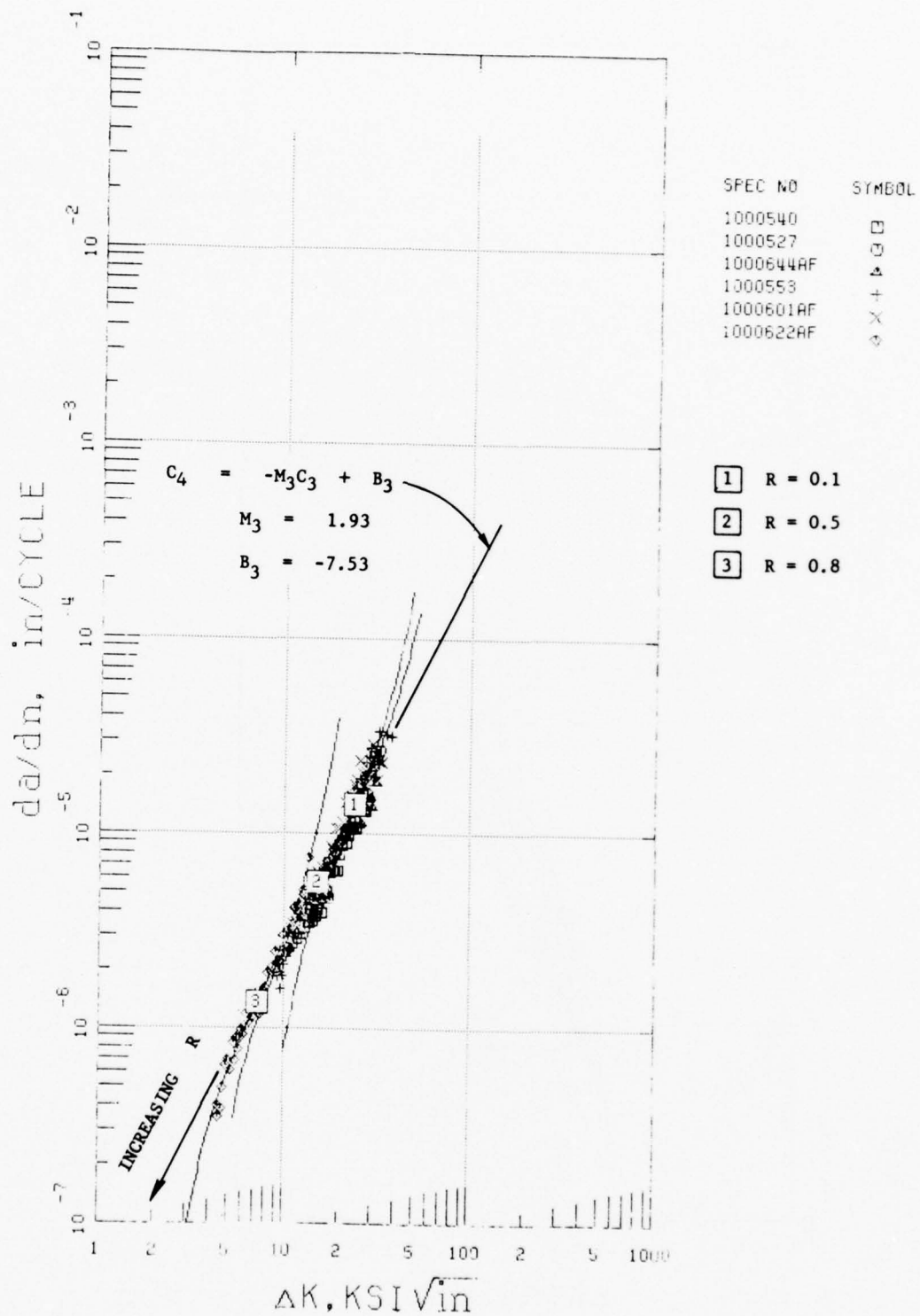

Figure 6. Effect of Stress Ratio on Crack Growth in IN-100 20 cps, 1200°F

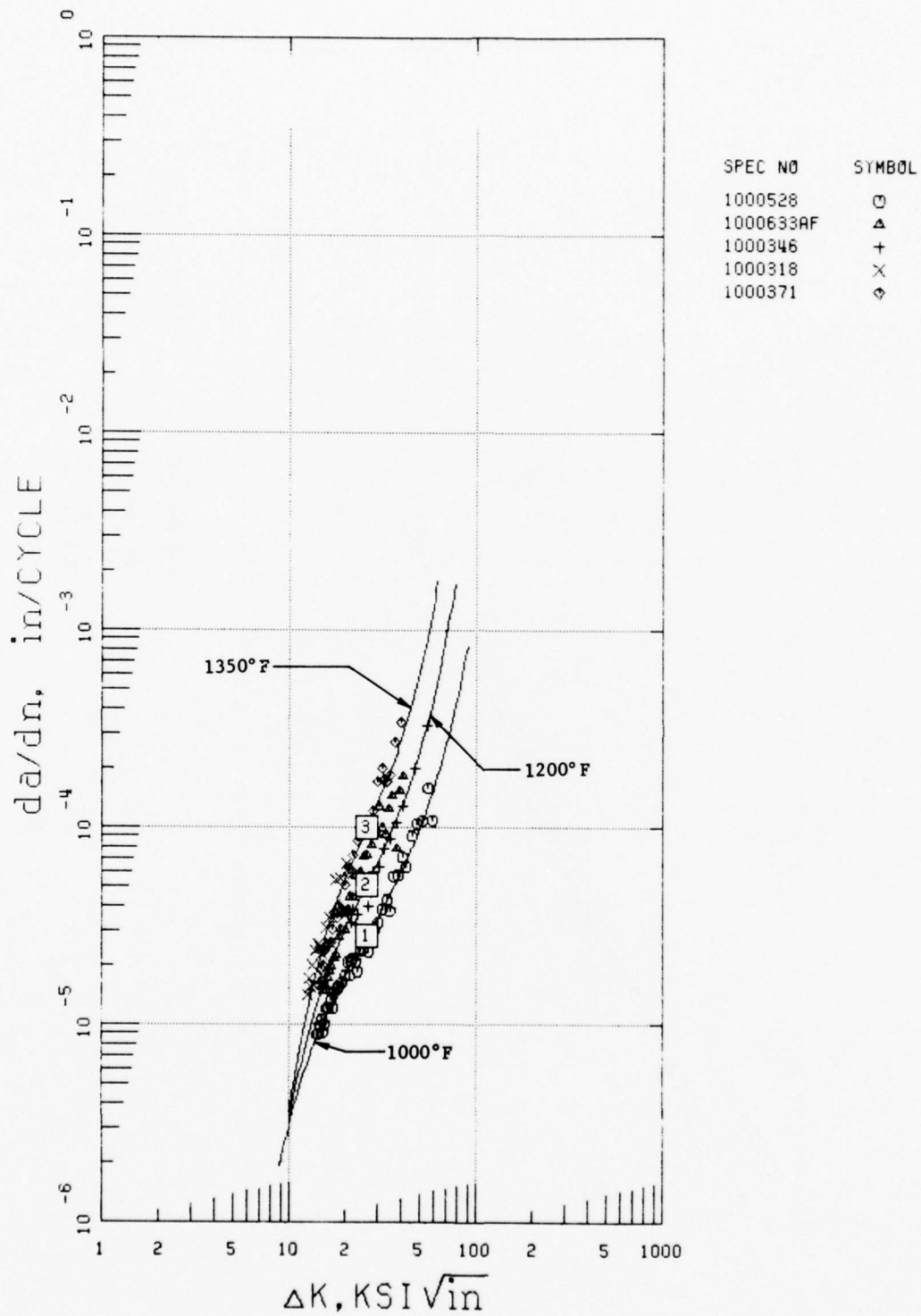

Figure 7. Effect of Temperature on Crack Growth in IN-100, 10 cpm, $R = 0.1$

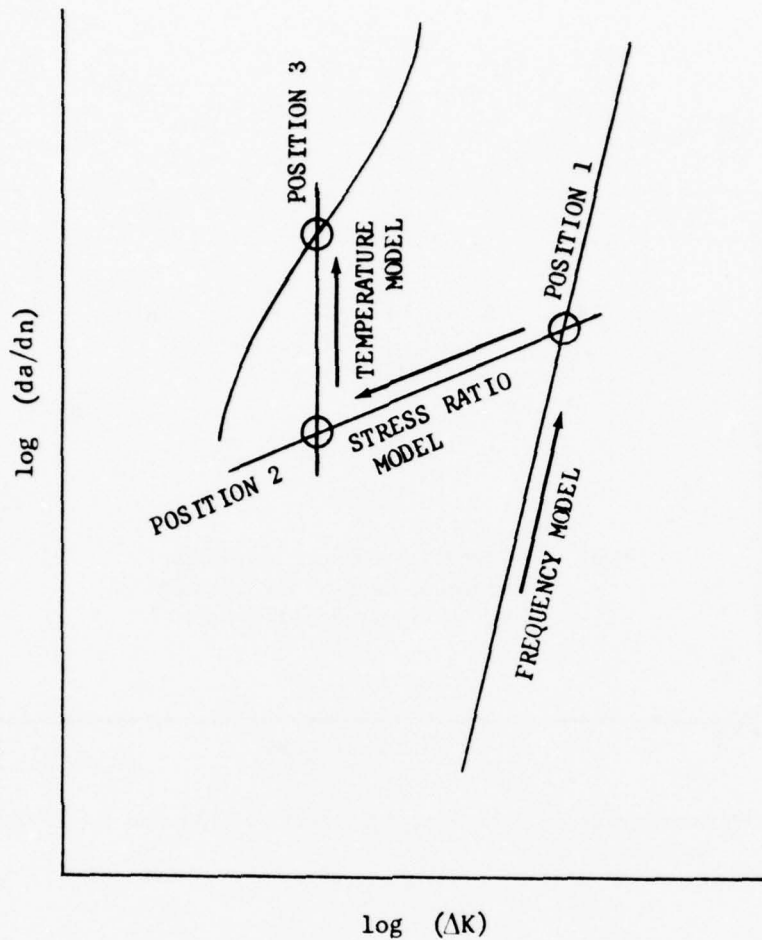

Figure 8. Schematic Representation of the Method for Determining SINH Model Coefficients Representing Any Frequency, Stress Ratio, and Temperature

If a realistic load-time mission is broken down into small segments, the segments can be represented by synergistic empirical models. Linear superposition of damage for each mission segment can be used to predict crack propagation life. Care must be taken when dividing the mission to ensure minimum segment interaction at the division points. For example, major load excursions affect the cycles following to a greater degree than they are affected by those which proceed, mission division should be immediately prior to an excursion rather than after. (See Figure 9, segments 4 and 7.)

The interpolative hyperbolic sine model is ideal for representing crack propagation data of complex missions since it requires only a minimum number of tests. Both acceleration and retardation of the crack growth rate caused by overloads can be accurately represented. The SINH does not attempt to model the micromechanical physical deformation near the crack tip, but empirically describes the macroscopic behavior of the crack.

This model is discussed in detail in Section III.

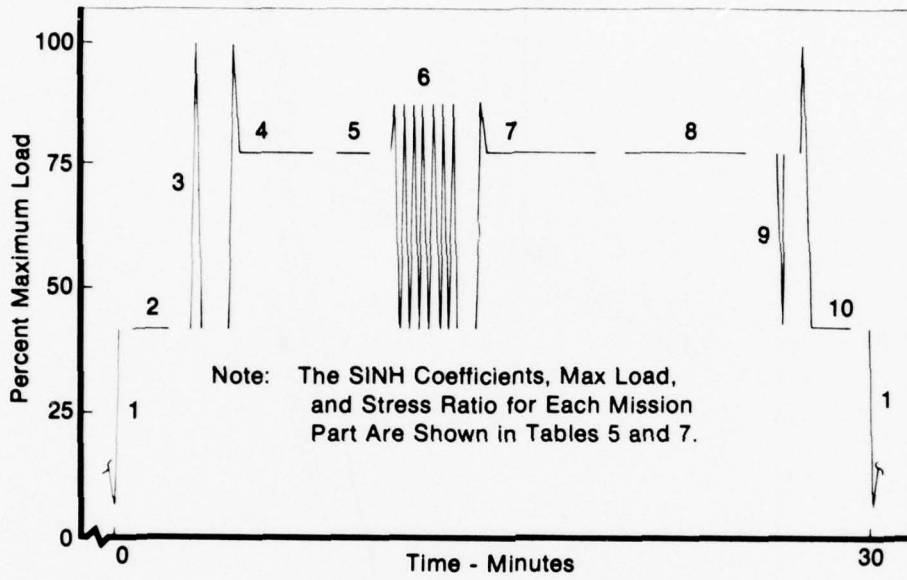

Figure 9. Incrementation of Simulated Turbine Disk Mission for 1200°F, Retardation Model

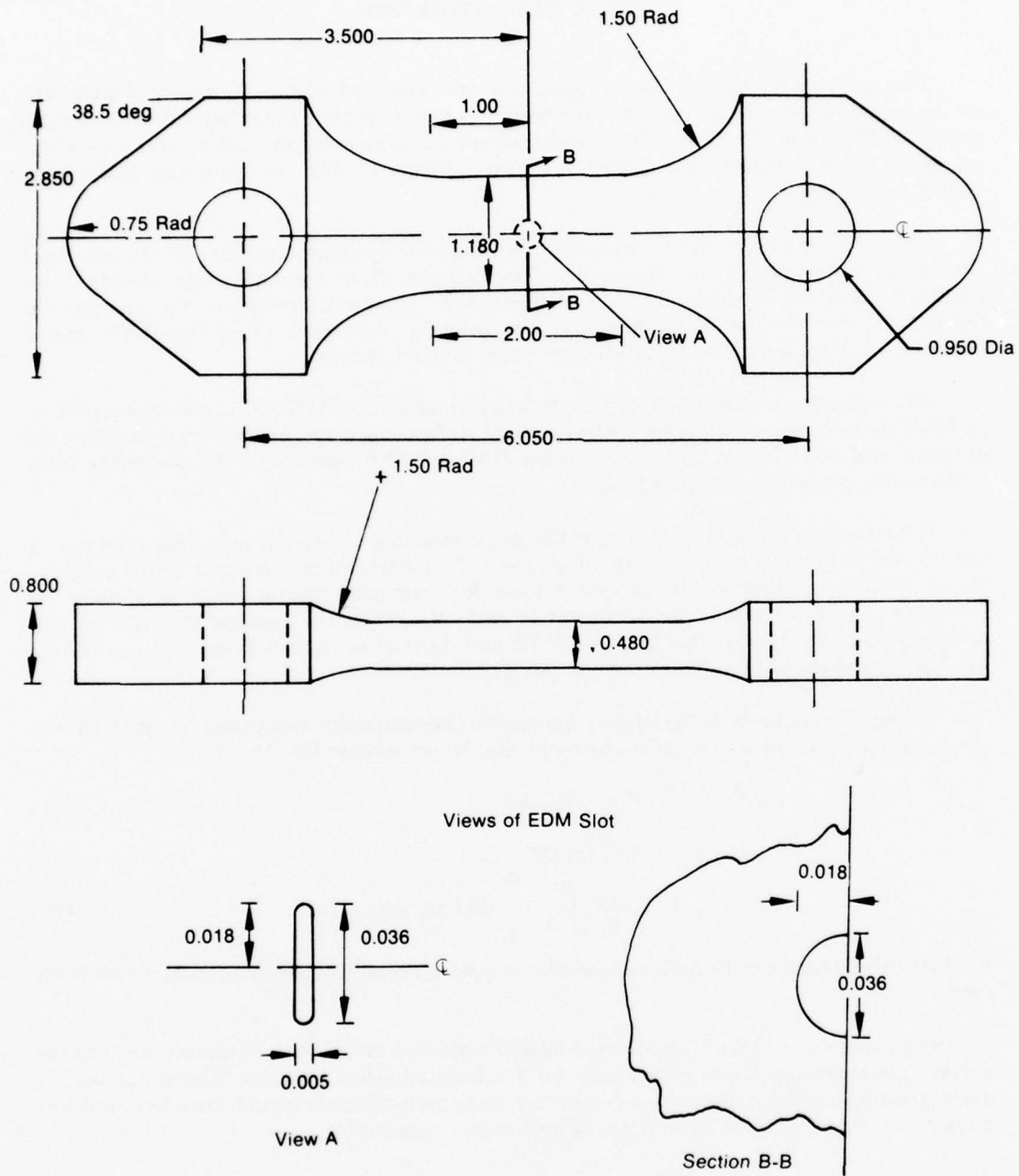
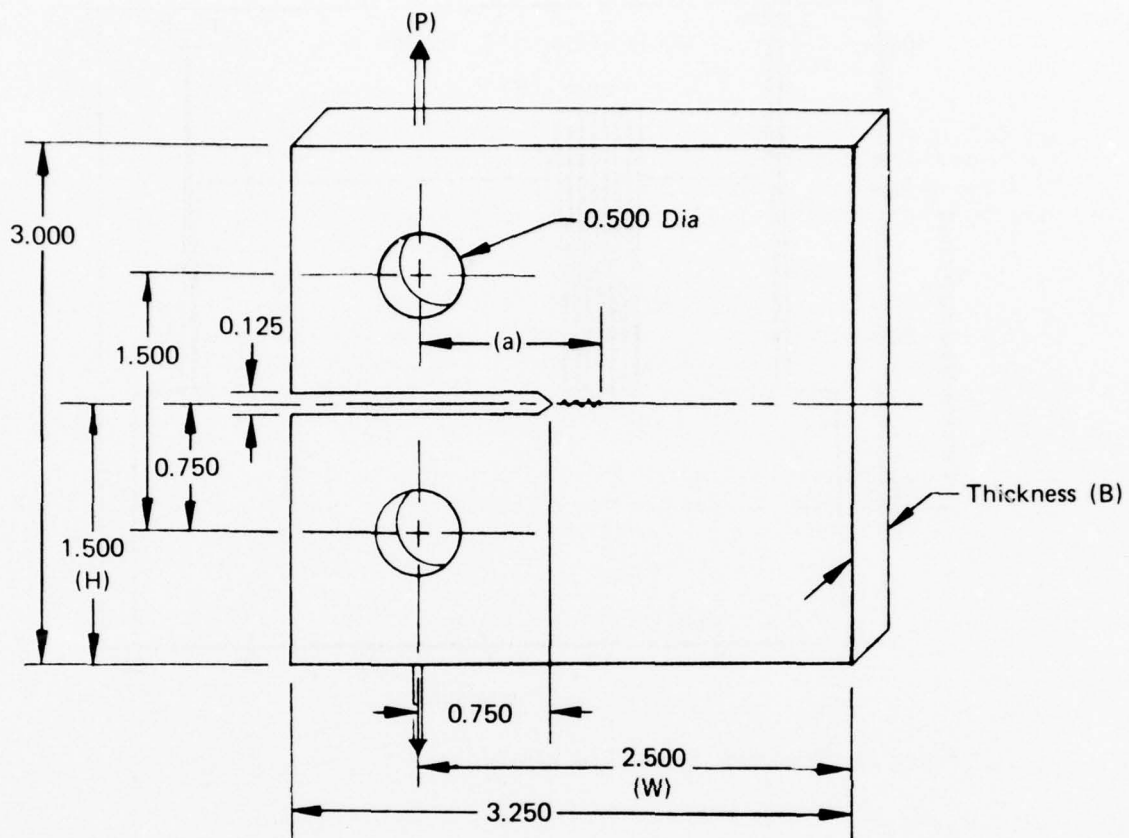

Figure 10. Surface Flaw Specimen



K Calibration:

$$K = Y \frac{P}{BW} \sqrt{a}$$

for $a/w = 0.3 - 0.7$; $H/W - H/W = 0.6$

$$Y = f(a/w) = [0.2960 - 1.855(a/w) + 6.557(a/w)^2 - 10.17(a/w)^3 + 6.389(a/w)^4] 10^2$$

Accuracy: 0.5%

Net Section Stress;

$$\sigma_{\text{Net}} = \frac{KW^{1/2}}{f(a/w)(w-a)} \left[1 + \frac{3(w+a)}{(w-a)} \right]$$

Figure 11. Modified Compact Tension Specimen

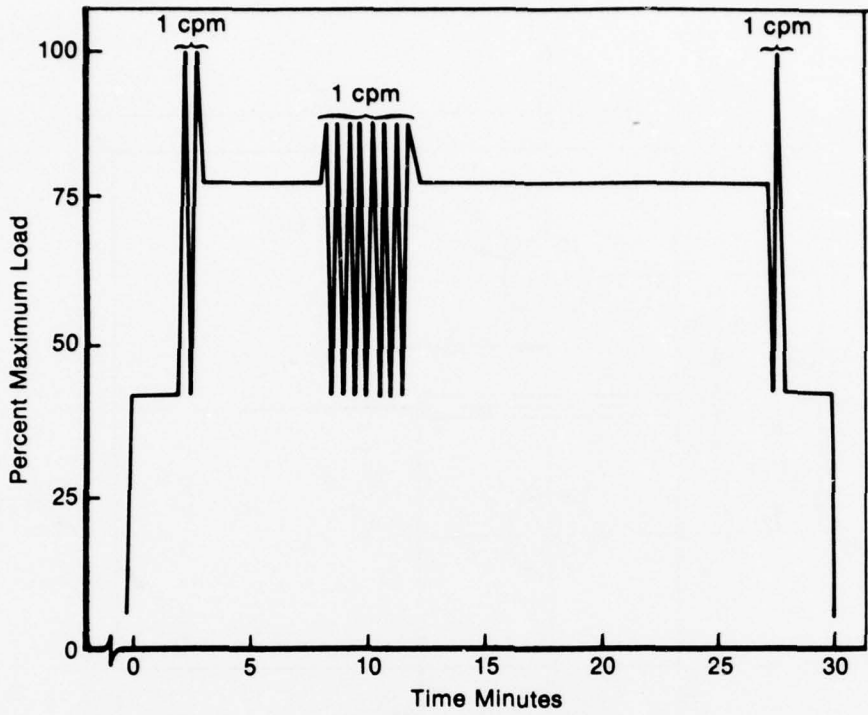

Figure 12. Simulated Turbine Disk Mission

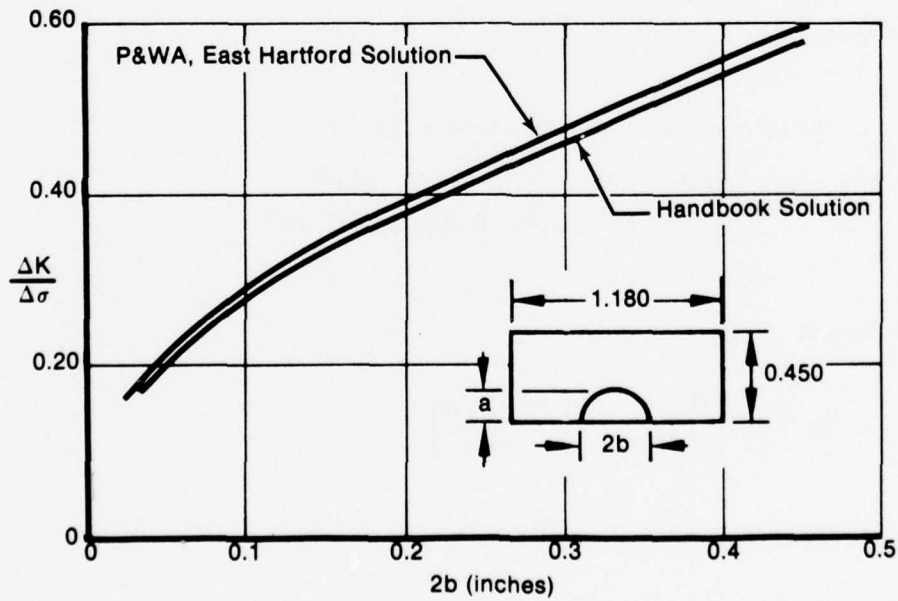

Figure 13. Comparison of K-Calibration Curves for Surface Flaw Specimen

A computer program has been developed to perform crack propagation life analyses using (1) linear superposition of individual components within a mission, and (2) empirical synergistic models. The program predicts the life of specimens tested under variable amplitude cyclic, cyclic-dwell, and/or dwell conditions. Currently, a total of twenty separate segments within a given mission can be incrementally integrated to predict crack propagation life. The empirical inputs describing crack propagation within the mission segments are the interpolative SINH model coefficients.

The program provides, as output, computer drawn (GOULD) plots of the actual a vs N data (included as input) and the predicted a vs N relationship. This allows direct comparison of predicted vs actual data. Appendix C shows an example of the complete program input.

Instructions for use of the program are given in Appendix A. The actual program is listed in Appendix B.

LIFE ANALYSIS AT 1000°F

Figure 14 shows the test mission segmented into appropriate regions for analysis at 1000°F. Two assumptions are made in this analysis. First, it is assumed that sustained load crack propagation does not occur under the test conditions. This is based on the observation that there was no significant difference between 10 cpm and 2-minute dwell crack propagation rates at 1000°F (Reference 1). Second, it is assumed that no synergism occurs. This is necessary because there are no data yet available on overload effects at 1000°F for IN-100. Therefore, the predictions are based on interpolations of the SINH model for the cyclic portions, assuming sustained load crack propagation to be insignificant.

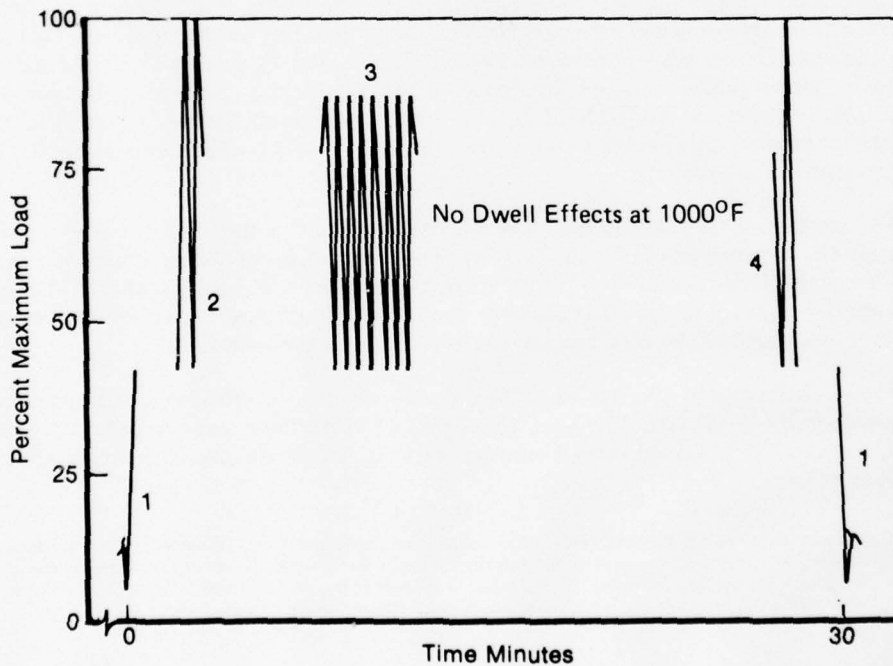

Figure 14. Incrementation of Simulated Turbine Disk Mission for 1000°F

All predicted mission lives, and a vs N relationships were computed and published prior to testing, in PWA FR-7906 Quarterly Progress Narrative No. 6, 15 September 1976.

The SINH equation for 10 cpm, $R = 0.1$ crack growth rate at 1000°F was used as the starting point for calculating the hyperbolic sine coefficients for each segment of the 1000°F mission. It is assumed that stress ratio effects at 1000°F are similar to stress ratio effects at 1200°F. Since frequency effects on crack propagation rates would be less at 1000°F than at 1200°F because of reduced environmental degradation (oxidation, Reference 1), the difference between 1 cpm and 10 cpm crack growth rates at 1000°F is considered to be negligible.

The prediction, published before testing, for the surface flaw specimen (Figure 15) was conservative. The accuracy ($N_{pred}/N_{actual} = 0.91$) of the prediction is encouraging, since only two tests had been conducted at 1000°F (10 cpm, $R = 0.1$ and 2-minute dwell, $R = 0.1$) prior to this mix mission test. The actual a vs N data has the same shape as the predicted a vs N relationship indicating both an accurate K-solution and an accurate predictive model.

The prediction, published prior to testing, for the MCT specimen (Figure 16) was anticonservative. The accuracy was good ($N_{pred}/N_{actual} = 1.12$), and the shape of the actual data is close to the predicted shape. No explanation is offered for the anticonservative behavior of the MCT specimen.

Tables 2 and 3 present the SINH equation coefficients, and other parameters for the surface flaw specimen and the MCT specimen, respectively.

LIFE ANALYSIS AT 1200°F

Figure 17 shows the test mission segmented into appropriate parts for linear superposition (no synergistic interactions) life analysis at 1200°F. The interpolative hyperbolic sine model (Reference 1) provides crack growth equations for exact operating conditions during each segment of the mission. Linear superposition of the damage caused by each part of the mission (no synergistic interactions) resulted in conservative predictions for both the surface flaw ($N_{pred}/N_{actual} = 0.57$) and MCT ($N_{pred}/N_{actual} = 0.42$) specimens. Figures 18 and 19 respectively illustrate the results, and Tables 4 and 5 give the SINH equation coefficients and other data for each segment of the mission.

The more realistic prediction uses a retardation SINH model (Reference 6) to represent accurately the damage caused by the mission. The retardation model is segmented as shown in Figure 9 with SINH equation coefficients for each part shown in Tables 6 and 7. The retardant or accelerative effect of overloads (mission parts 4, 7 and 10, Figure 9) has been modeled for the first 5 minutes of sustained load crack growth using the hyperbolic sine.*

Figure 20 illustrates the effects of 25% and 50% repetitive overloads on sustained load crack propagation in IN-100 at 1200°F. Sustained load data (no overloads) are compared with sustained load data plus a 25% overload every 2 minutes, and with sustained load data plus a 50% overload every 2 minutes.

*While the mission data used 2-minute dwell periods, it has been shown previously (Reference 7) there is no significant difference between 1-, 2-, and 5-minute constant amplitude tensile dwell cycles. However, there is a difference between 5-minute and 10-minute dwells. Therefore, it is postulated that there is a critical incubation period (between 5 and 10 minutes) before oxidation becomes the crack propagation rate controlling mechanism.

SPECIMEN NUMBER 651 SURFACE FLAW
 INITIAL CRACK 0.068 INCHES
 MAX LOAD 50,000 KIPS
 TEMPERATURE 1000 DEGREES F
 STRESS RATIO MIXED
 FREQUENCY LUKE MISSION

△ ACTUAL DATA 966 MISSIONS
 — PREDICTED 996 MISSIONS

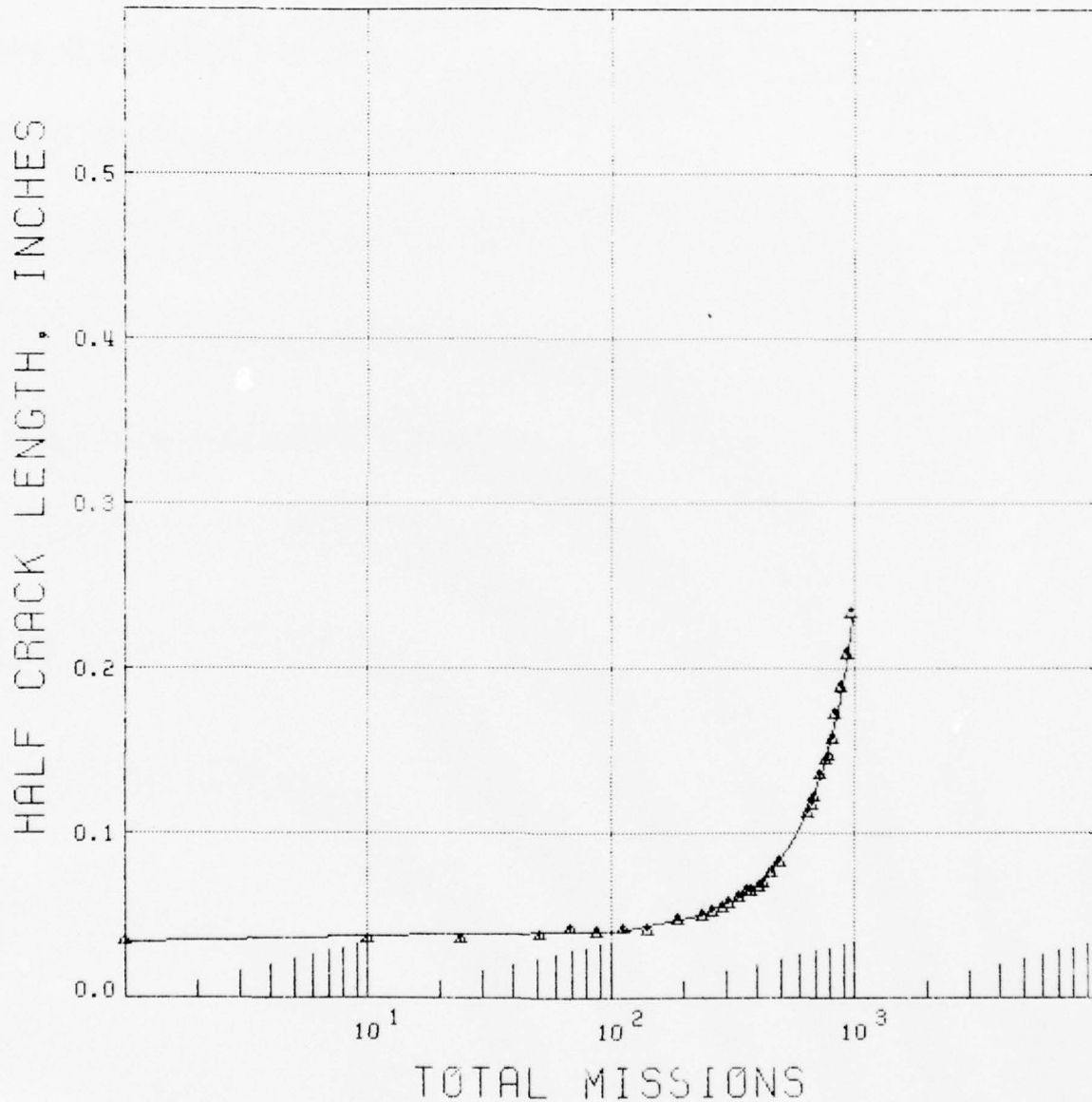

Figure 15. Surface Flaw Specimen Crack Growth Prediction, Interpolative Hyperbolic Sine Model, No Synergistic Interaction, Linear Superposition

SPECIMEN NUMBER	882	MCT SPECIMEN
INITIAL CRACK	1.193	INCHES
MAX LOAD	8,000	LBS
TEMPERATURE	1000	DEGREES F
STRESS RATIO	MIXED	
FREQUENCY	LOVE	MISSIONS

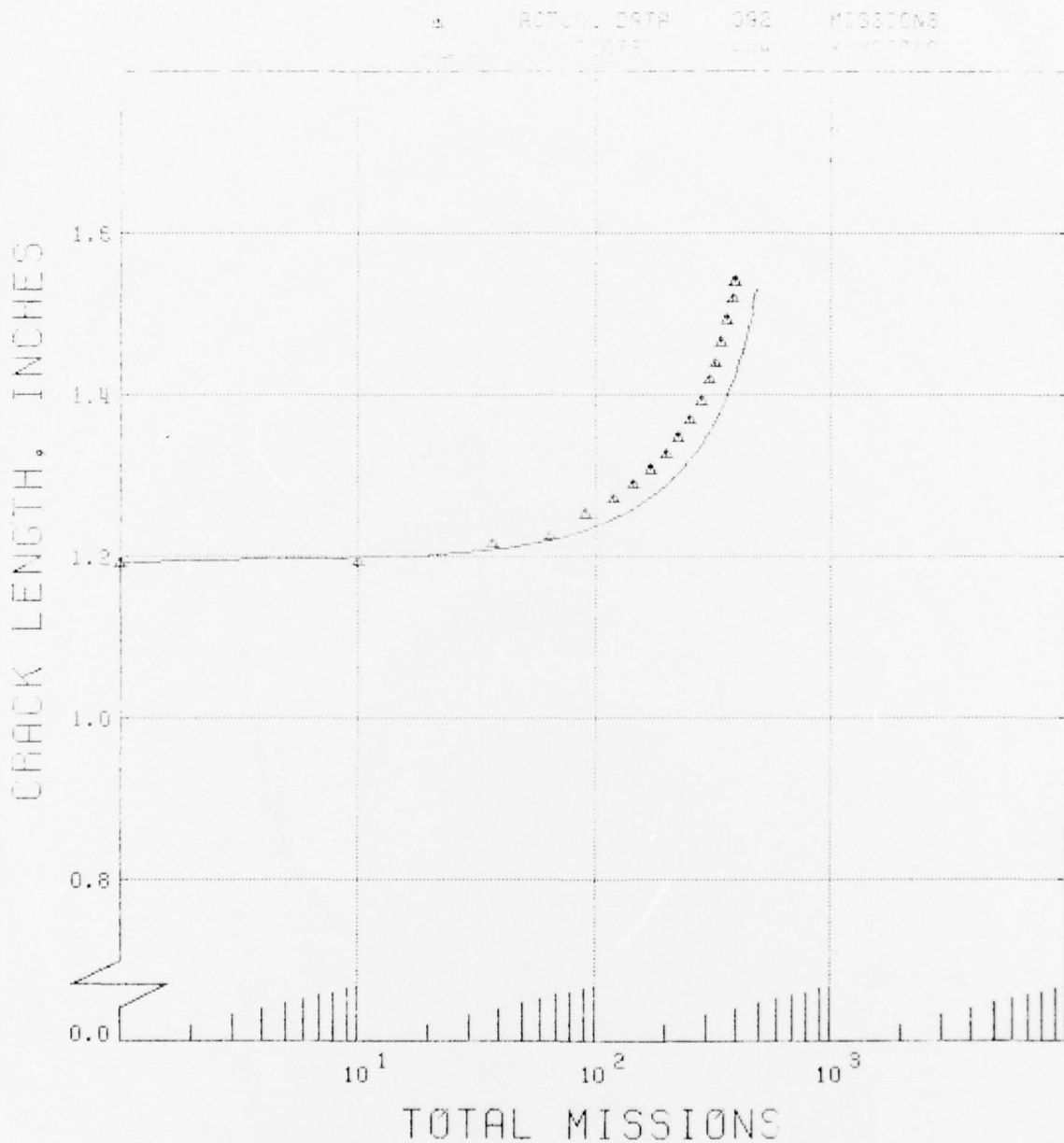

Figure 16. Modified Compact Tension Specimen Predicted Crack Growth, Interpolative Hyperbolic Sine Model, No Synergistic Interaction, Linear Superposition

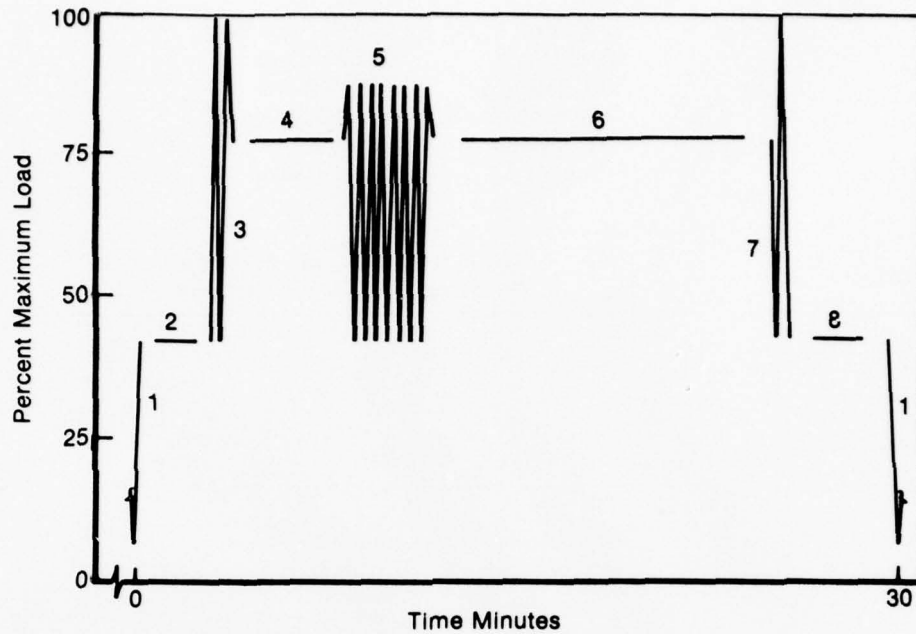

Figure 17. Incrementation of Simulated Turbine Disk Mission for 1200°F, Linear Superposition

TABLE 2. SPECIMEN 651 SURFACE FLAW SPECIMEN 1000°F

Width = 1.174 Thickness = 0.428 Initial Crack Length = 0.030

SINH Coefficients				Max* Load	Stress Ratio	Mission Part
C1	C2	C3	C4			
0.500	3.320	-1.417	-4.550	23.000	0.1	1
0.500	4.151	-1.278	-4.679	50.000	0.5	2
0.500	4.151	-1.278	-4.679	44.500	0.5	3
0.500	4.151	-1.278	-4.679	50.000	0.5	4

*All loads are in Kips.

TABLE 3. SPECIMEN 652 MCT SPECIMEN 1000°F

Width = 2.503 Thickness = 0.847 Initial Crack Length = 1.000

SINH Coefficients				Max* Load	Stress Ratio	Mission Part
C1	C2	C3	C4			
0.500	3.320	-1.417	-4.550	4.600	0.1	1
0.500	4.151	-1.278	-4.679	10.000	0.5	2
0.500	4.151	-1.278	-4.679	8.900	0.5	3
0.500	4.151	-1.278	-4.679	10.000	0.5	4

*All loads are in Kips

Specimen Number 650 Surface Flaw
 Initial Crack 0.059 inches
 Max Load 46.400 KIPS
 Temperature 1200 Degrees F
 Stress Ratio Mixed
 Frequency Luke Mission

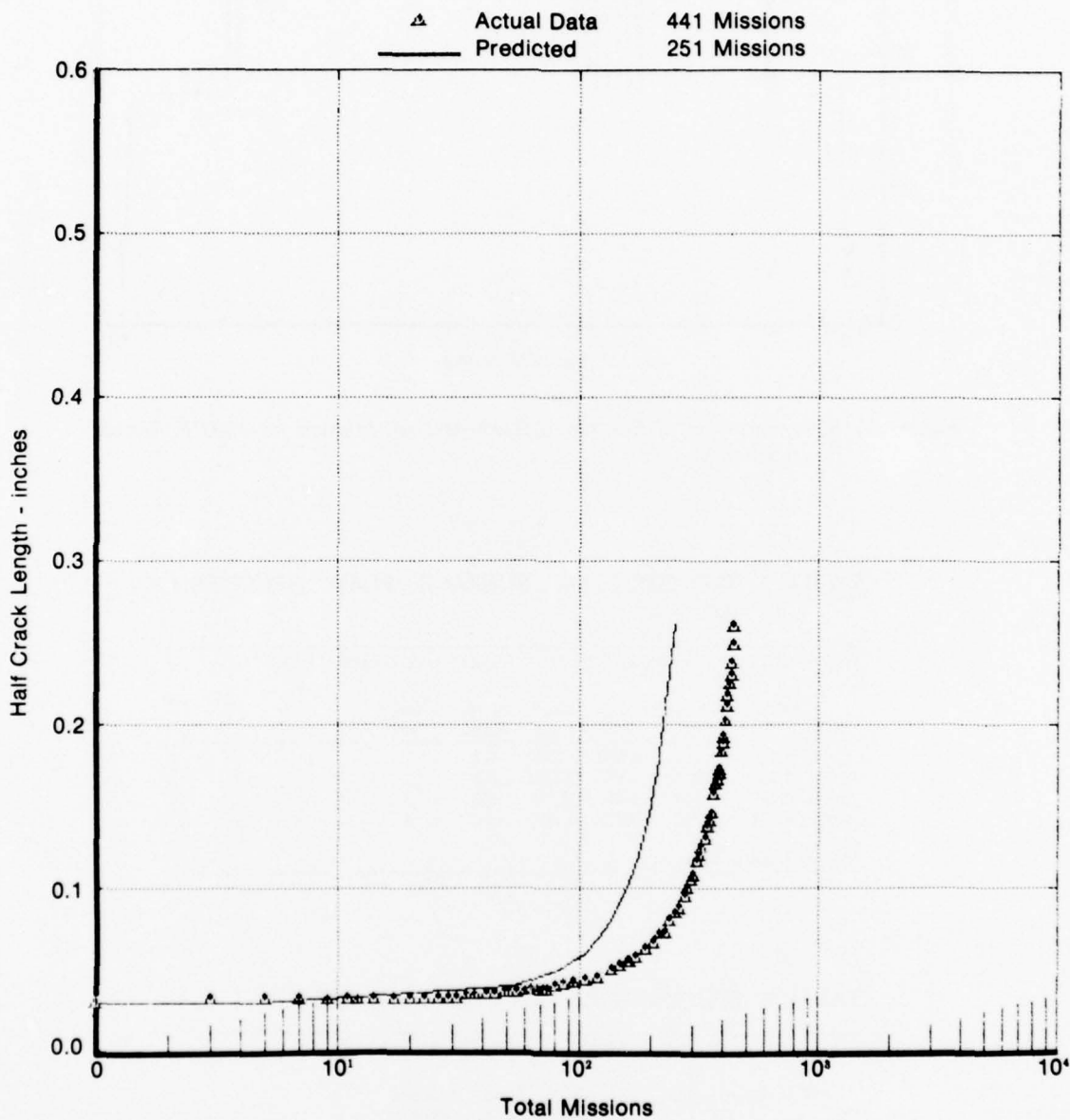

Figure 18. Surface Flaw Specimen Crack Growth Prediction, Interpolative Hyperbolic Sine Model, No Synergistic Interaction, Linear Superposition

SPECIMEN NUMBER 653 MCT SPECIMEN
 INITIAL CRACK 1.008 INCHES
 MAX LOAD 6.000 KIPS
 TEMPERATURE 1200 DEGREES F
 STRESS RATIO MIXED
 FREQUENCY MIXED MISSION

△ ACTUAL DATA 815 MISSIONS
 — PREDICTED 339 MISSIONS

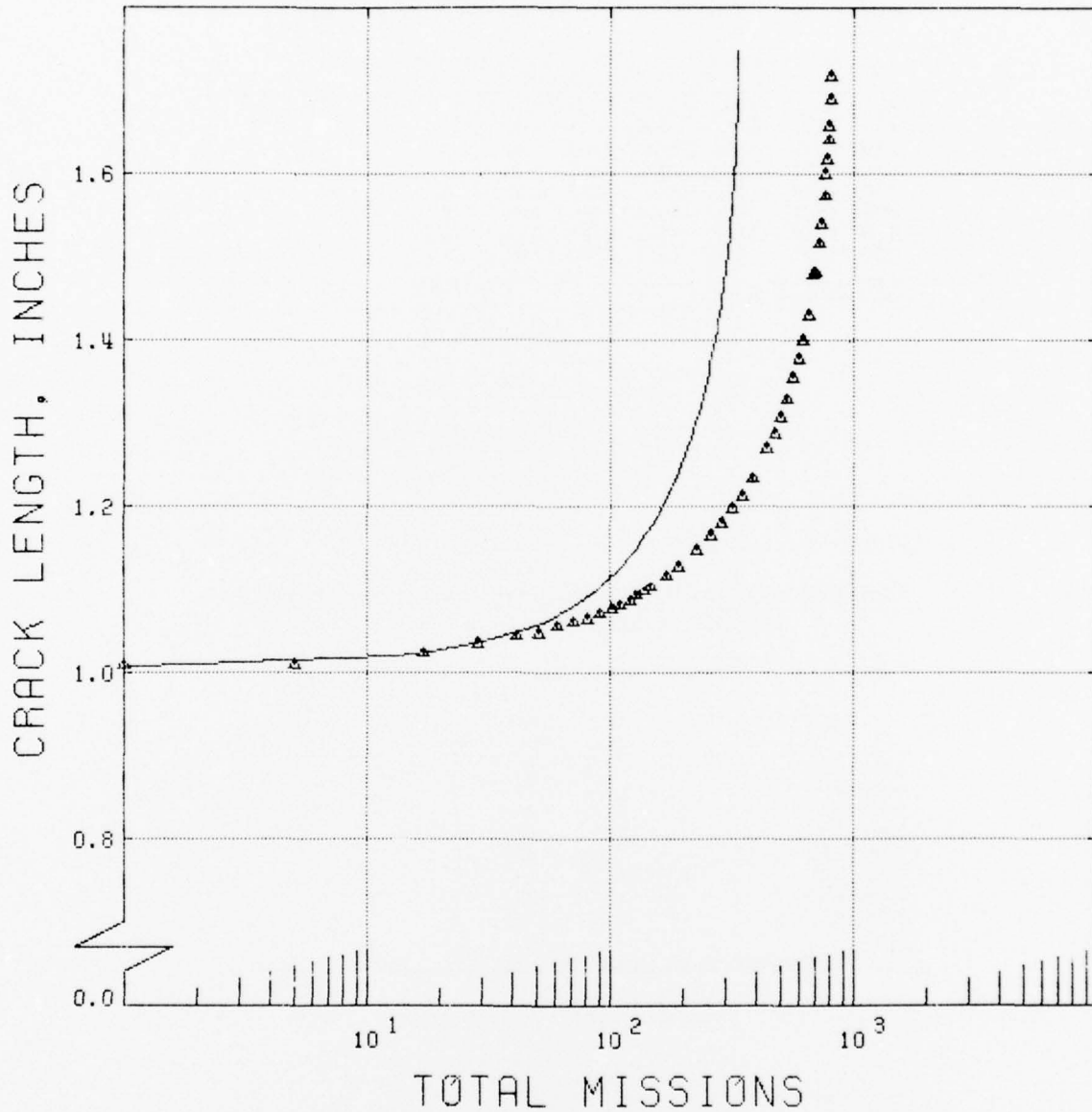

Figure 19. Modified Compact Tension Specimen Predicted Crack Growth, Interpolative Hyperbolic Sine Model, No Synergistic Interaction, Linear Superposition

TABLE 4. SPECIMEN 650 SURFACE FLAW SPECIMEN
1200°F, LINEAR SUPERPOSITION

Width = 2.509 Thickness = 0.851 Initial Crack Length = 1.0083

C1	SINH Coefficients			Max* Load	Stress Ratio	Mission Part
	C2	C3	C4			
0.500	3.938	-1.397	-4.156	2.760	0.20	1
0.500	4.297	-1.479	-2.519	2.760	1.00	2
0.500	4.116	-1.305	-4.241	6.000	0.46	3
0.500	4.297	-1.479	-2.519	4.680	1.00	4
0.500	4.169	-1.277	-4.267	5.340	0.52	5
0.500	4.297	-1.479	-2.519	4.680	1.00	6
0.500	4.116	-1.305	-4.241	6.000	0.46	7
0.500	4.297	-1.479	-2.519	2.760	1.00	8

*All loads are in Kips.

TABLE 5. SPECIMEN 653 MCT SPECIMEN 1200°F, LINEAR
SUPERPOSITION

Width = 1.171 Thickness = 0.449 Initial Crack Length = 0.02950

C1	SINH Coefficients			Max* Load	Stress Ratio	Mission Part
	C2	C3	C4			
0.500	3.938	-1.397	-4.156	21.344	0.20	1
0.500	4.297	-1.479	-2.519	21.344	1.00	2
0.500	4.116	-1.305	-4.241	46.400	0.46	3
0.500	4.297	-1.479	-2.519	36.192	1.00	4
0.500	4.169	-1.277	-4.267	41.296	0.52	5
0.500	4.297	-1.479	-2.519	36.192	1.00	6
0.500	4.116	-1.305	-4.241	46.400	0.46	7
0.500	4.297	-1.479	-2.519	21.344	1.00	8

*All loads are in Kips.

TABLE 6. SPECIMEN 650 SURFACE FLAW SPECIMEN
1200°F, RETARDATION

		Width = 1.171		Thickness = 0.449		Initial Crack Length = 0.0295	
	SINH Coefficients				Max*	Stress	Mission
	C1	C2	C3	C4	Load	Ratio	Part
0.500	3.938	-1.397	-4.156	21.344	0.20	1	
0.500	4.297	-1.479	-2.519	21.344	1.00	2	
0.500	4.116	-1.305	-4.241	46.400	0.46	3	
0.500	4.378	-1.633	-2.998	36.192	1.00	4	
0.500	4.297	-1.479	-2.519	36.192	1.00	5	
0.500	4.169	-1.277	-4.267	41.296	0.52	6	
0.500	4.292	-1.565	-2.807	36.192	1.00	7	
0.500	4.297	-1.479	-2.519	36.192	1.00	8	
0.500	4.116	-1.305	-4.241	46.400	0.46	9	
0.500	4.297	-1.479	-2.519	21.344	1.00	10	

*All loads are in Kips.

TABLE 7. SPECIMEN 653 MCT SPECIMEN 1200°F, RE-
TARDATION

		Width = 2.509		Thickness = 0.851		Initial Crack Length = 1.0083	
	SINH Coefficients				Max*	Stress	Mission
	C1	C2	C3	C4	Load	Ratio	Part
0.500	3.938	-1.397	-4.156	2.760	0.20	1	
0.500	4.297	-1.479	-2.519	2.760	1.00	2	
0.500	4.116	-1.305	-4.241	6.000	0.46	3	
0.500	4.378	-1.633	-2.998	4.680	1.00	4	
0.500	4.297	-1.479	-2.519	4.680	1.00	5	
0.500	4.169	-1.277	-4.267	5.340	0.52	6	
0.500	4.292	-1.565	-2.807	4.680	1.00	7	
0.500	4.297	-1.479	-2.519	4.680	1.00	8	
0.500	4.116	-1.305	-4.241	6.000	0.46	9	
0.500	4.297	-1.479	-2.519	2.760	1.00	10	

*All loads are in Kips.

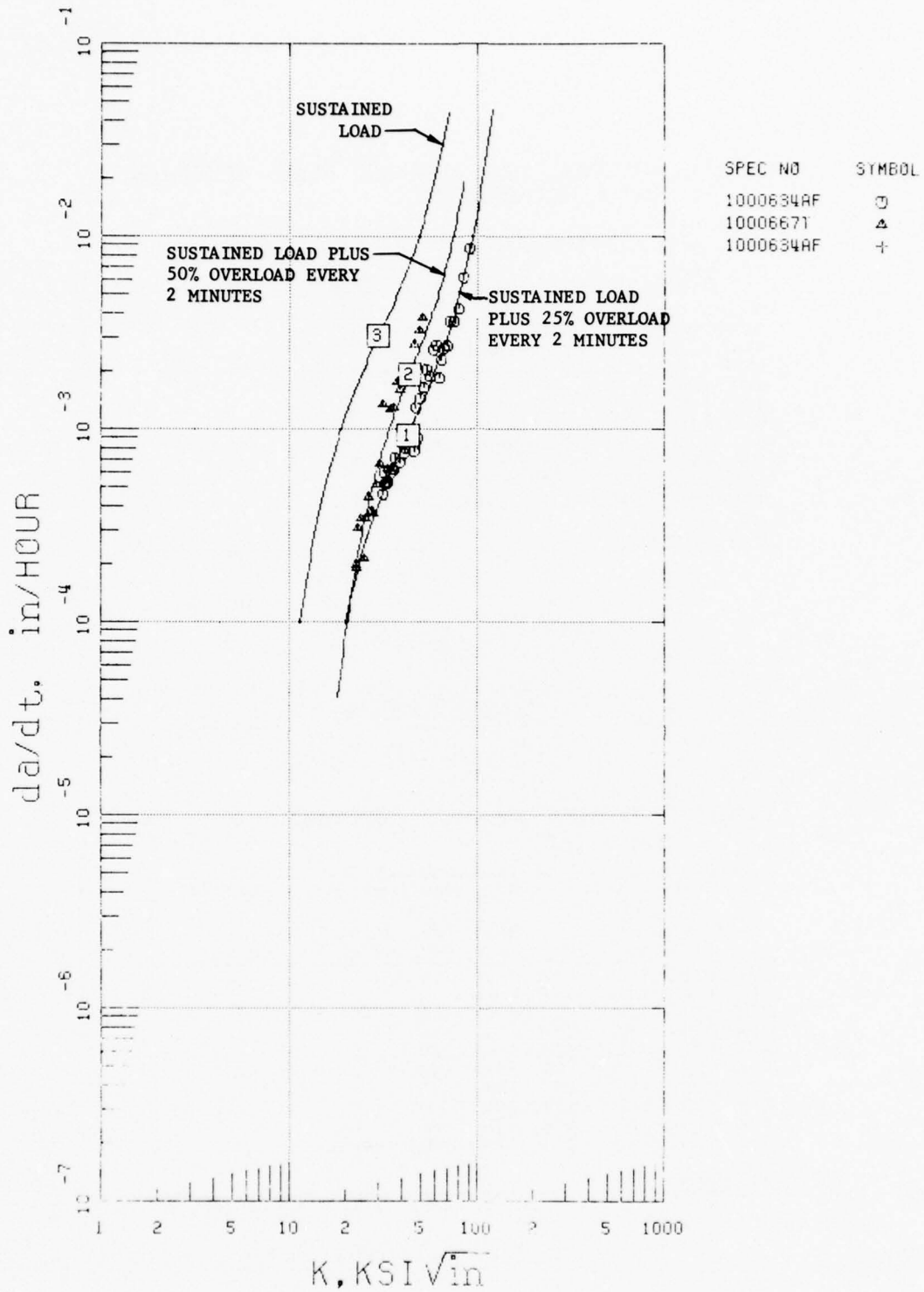

Figure 20. Effect of 25% and 50% Multiple Overloads on Sustained Load Crack Growth in IN-100, 1200°F

The following equations detail the relationships between overload ratio (OLR) and the resulting SINH coefficients which model crack growth rate.

The model used to determine synergistic SINH equation coefficients for mission parts 4, 7 and 10 (Figure 9) is defined as follows:

$$\begin{aligned} \text{For } 1.0 \leq \text{OLR} \leq 1.25 \quad C_1 &= 0.5 \\ C_2 &= -0.036 (\text{OLR}) + 4.333 \\ C_3 &= -0.612 (\text{OLR}) - 0.867 \\ C_4 &= -2.056 (\text{OLR}) - 0.463 \end{aligned}$$

$$\begin{aligned} \text{For } 1.25 \leq \text{OLR} \leq 1.5 \quad C_1 &= 0.5 \\ C_2 &= 3.016 (\text{OLR}) + 0.518 \\ C_3 &= -0.04 (\text{OLR}) - 1.582 \\ C_4 &= 1.25 (\text{OLR}) - 4.598 \end{aligned}$$

The SINH equation coefficients for the other mission parts are for exact conditions using the interpolative SINH model developed in Reference 1.

The retardation prediction for the surface flaw specimen is very accurate ($N_{\text{pred}}/N_{\text{actual}} = 0.98$) as shown in Figure 21. The actual data has the shape predicted, indicating an accurate K-solution and an accurate predictive synergistic model.

The MCT specimen synergistic prediction was more accurate ($N_{\text{pred}}/N_{\text{actual}} = 0.69$) than the linear superposition prediction, but it was still conservative (Figure 22). The shape of the actual a vs N data is slightly different from the prediction. A check was made to determine if this discrepancy could be due to the test load being much higher than precrack load. The higher load could have created a reduction in crack curvature causing apparent accelerated crack growth at the beginning of the test. Starting the prediction at a longer crack length, after the precrack effects have disappeared (17 missions), matches the predicted shape to the actual data in the early part of the test (Figure 23), but there is apparently more retardation at higher stress intensities than predicted by the model.

The accuracy of the MCT K-solution (as well as the computer program accuracy) was checked by predicting the life of a simple cyclically loaded specimen. An MCT specimen was tested at 1100°F, $R = 0.3$, at 2 cpm, and the actual da/dn vs ΔK data was fit with the hyperbolic sine equation. This regressed equation was then integrated by the life analysis program to determine if the actual a vs N data could be reproduced, indicating an accurate K-solution. Figure 24 shows the predicted data matches the actual data very well. This indicates that the inaccurate mission mix prediction for the MCT specimen was not caused by an inaccurate K-solution.

Figure 25 compares the 1000°F linear superposition surface flaw prediction with the 1200°F linear superposition surface flaw prediction and the 1200°F retardation model surface flaw prediction. Each prediction used the same load and the same starting crack lengths.

Specimen Number 650 Surface Flaw
 Initial Crack 0.059 inches
 Max Load 46.400 KIPS
 Temperature 1200 Degrees F
 Stress Ratio Mixed
 Frequency Luke Mission



Figure 21. Surface Flaw Specimen Crack Growth Prediction, Interpolative Hyperbolic Sine Model, Retardation Model

SPECIMEN NUMBER	853	MCT SPECIMEN
INITIAL CRACK	1.008	INCHES
MAX LOAD	6.000	KIPS
TEMPERATURE	1200	DEGREES F
STRESS RATIO	MIXED	
FREQUENCY	LUKE	MISSION

△	ACTUAL DATA	815	MISSIONS
—	PREDICTED	562	MISSIONS

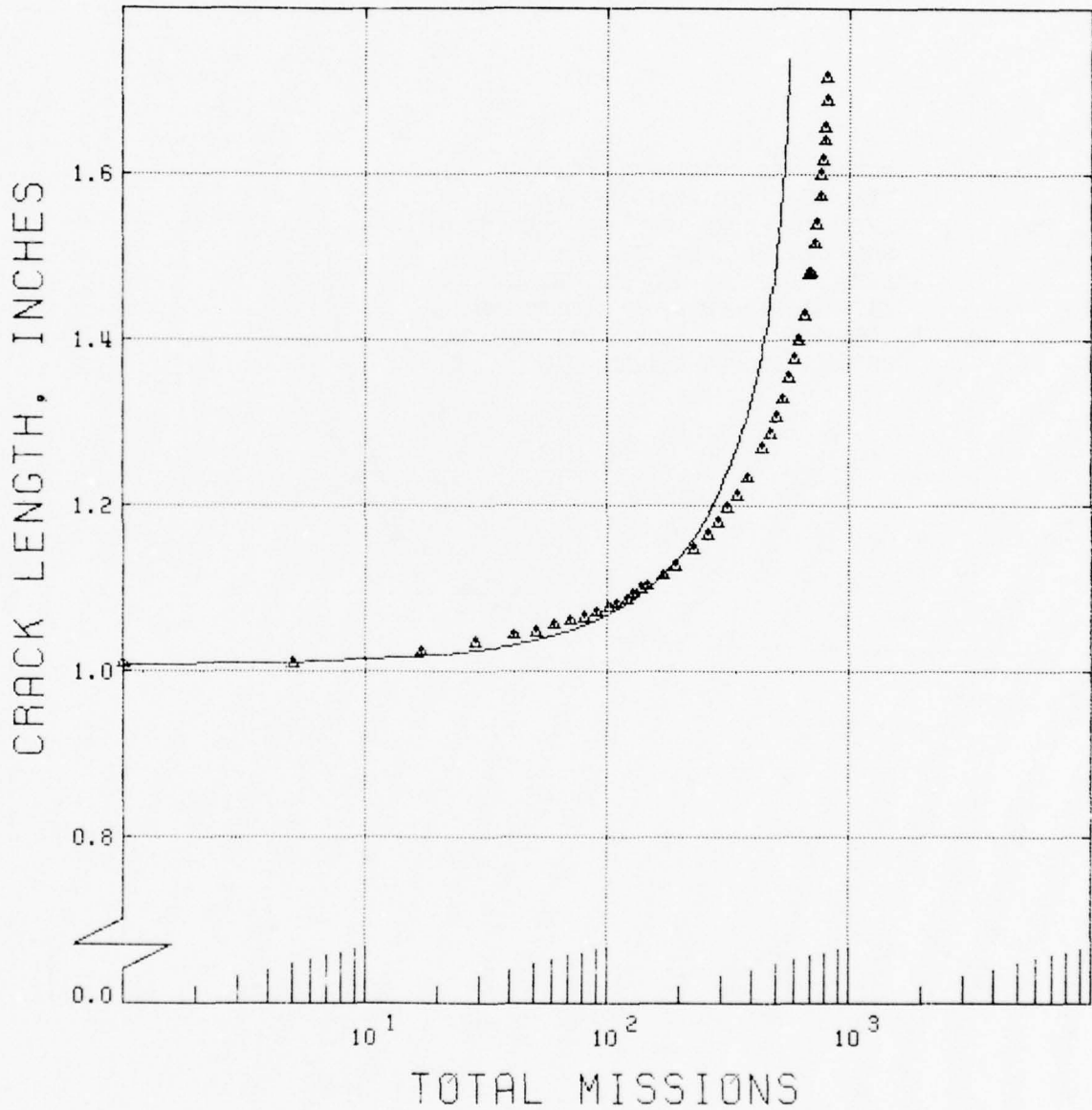

Figure 22. Modified Compact Tension Specimen Predicted Crack Growth, Interpolative Hyperbolic Sine Model, Retardation Model

SPECIMEN NUMBER	653	MCT SPECIMEN
INITIAL CRACK	1.024	INCHES
MAX LOAD	6.000	KIPS
TEMPERATURE	1200	DEGREES F
STRESS RATIO	MIXED	
FREQUENCY	LUK ³	MISSION

△	ACTUAL DATA	798	MISSIONS
-----	PREDICTED	536	MISSIONS

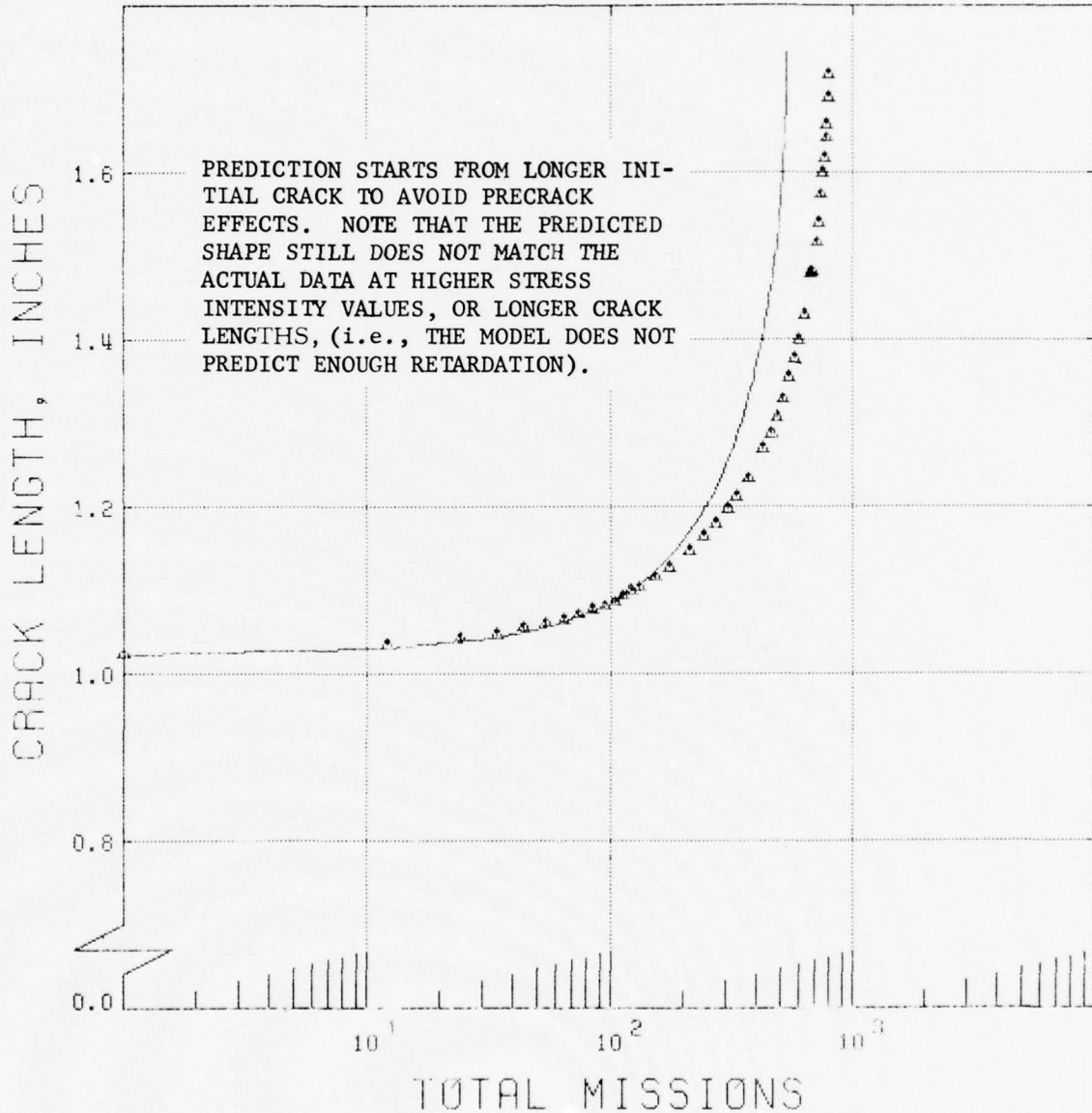

Figure 23. Modified Compact Tension Specimen Predicted Crack Growth, Interpolative Hyperbolic Sine Model, Retardation Model

SPECIMEN NUMBER 696 MCT SPECIMEN
 INITIAL CRACK 0.884 INCHES
 MAX LOAD 1.195 KIPS
 TEMPERATURE 1100 DEGREES F
 STRESS RATIO 0.3
 FREQUENCY 2 CPM MISSION

▲ ACTUAL DATA 14510 MISSIONS
 — PREDICTED 14613 MISSIONS

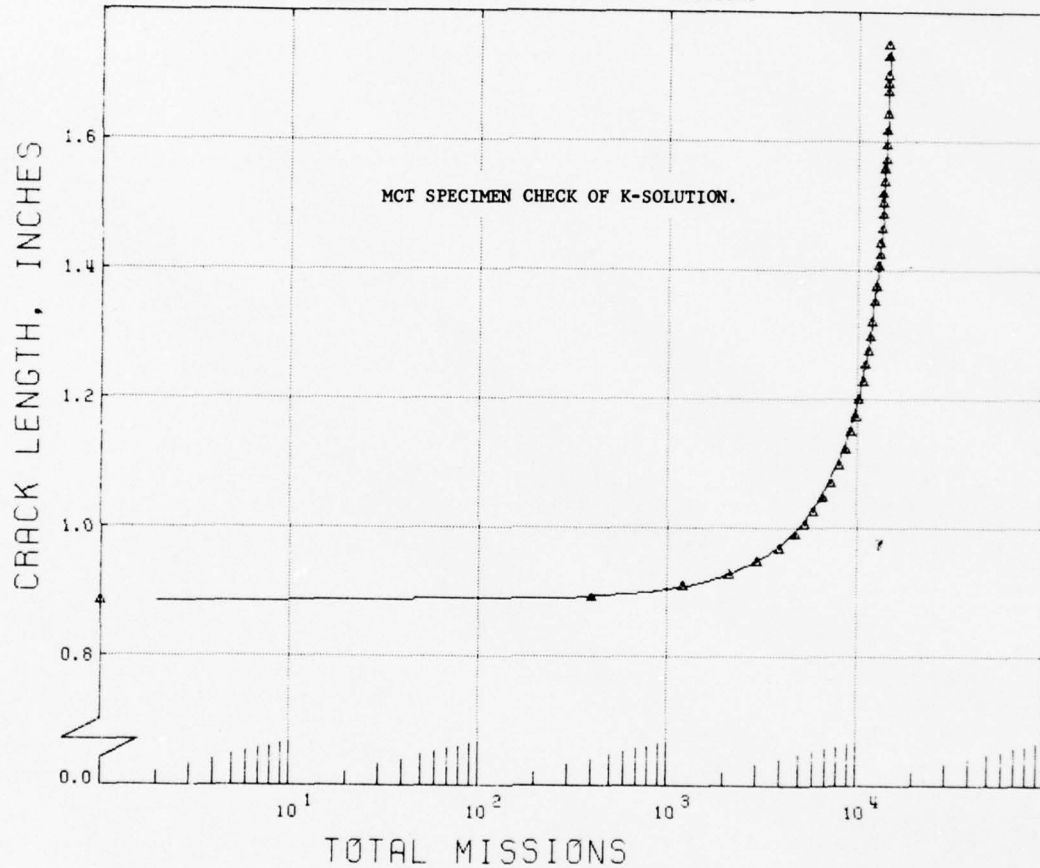

Figure 24. Modified Compact Tension Specimen Predicted Crack Growth, Interpolative Hyperbolic Sine Model, No Synergistic Interaction, Linear Superposition

Prediction	Description
1	1200°F, Linear Superposition, No Synergistic Interaction
2	1200°F, Sinh Retardation Model
3	1000°F, Linear Superposition, No Synergistic Interaction

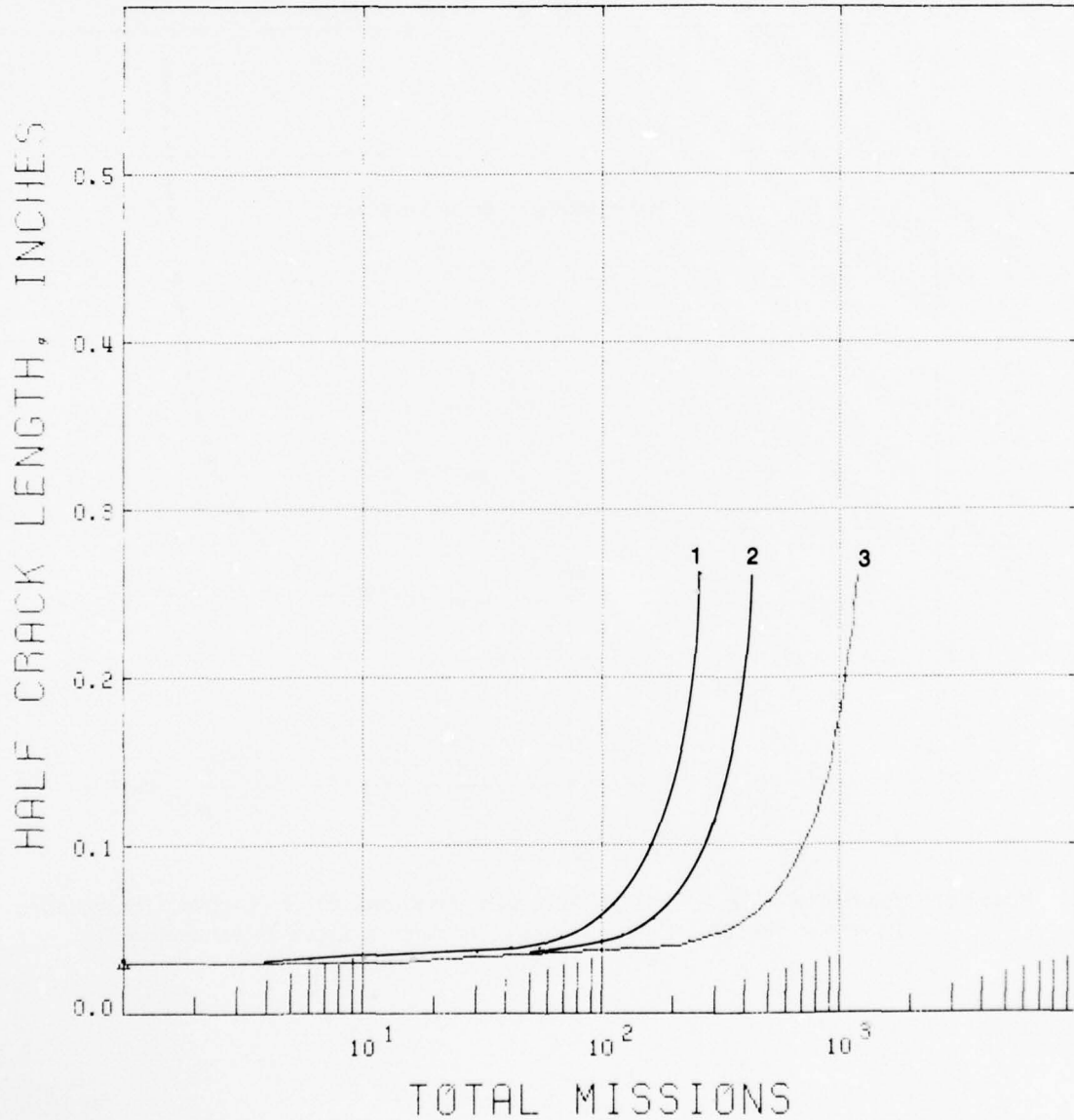

Figure 25. Comparison of 1000°F and 1200°F Linear Superposition Predictions With the 1200°F Retardation Prediction

SECTION IV CRITIQUE

The hyperbolic sine model has been demonstrated to provide accurate life predictions for crack propagation at elevated temperatures under complex mission spectra. The accuracy of the predictions for the surface crack specimens ($N_{pred}/N_{actual} = 0.91$ and 0.98) was better than for the modified compact tension specimens ($N_{pred}/N_{actual} = 1.12$ and 0.69). This result is interesting since the bulk of the data used in model development came from MCT specimens (Reference 1).

Figures 26 and 27 are macrofractographs of the fracture surfaces of the surface-crack specimens tested at 1000°F and 1200°F , respectively. The cracks behaved well and the assumption of a semicircular crack in the life analysis is verified by the fractographs. As expected, there is some evidence of crack turn back at the free surface. The absolute accuracy of the predictions and the agreement in predicted crack history (shape of the a vs N curves relative to actual data) leads to the conclusion that both the K-solution and the empirical SINH models are accurate.

Since the same models are used for the MCT specimen life predictions, a problem must exist with test procedures. Figures 28 and 29 are macrofractographs of the fracture surfaces of the MCT specimens tested at 1000°F and 1200°F , respectively. A shear lip is observed on the specimen tested at 1000°F . During constant amplitude load testing at 1000°F , 0.250-inch specimens did not exhibit shear lips up to $\Delta K = 50 \text{ KSI} \sqrt{\text{in}}$. The shear lip observed on this 0.85-in. specimen may therefore be an unexpected product of the major load excursions. Additionally, the lower temperatures create crack tip environments that are more conducive to mix mode conditions (Reference 6). The 1000°F model was developed with thinner (≤ 0.5 inch) specimen data and might be mixed mode (slower da/dN). The thicker demonstration specimen might be expected to exhibit a higher crack propagation rate because of increased plane strain constraint.

The specimen tested at 1200°F has considerable crack front curvature (10%). Crack curvature affects the accuracy of the K-solution and therefore the predicted crack history. This degree of curvature was not generally observed on thinner (0.25 in.) specimens subjected to mission mix cycling (Reference 6). The curvature observed here is a result of the curved precrack which resulted from room temperature (ductile) precrack cycling. Room temperature precracking in thinner specimens (≤ 0.5 in.), however, produces negligible crack front curvature, so the effect here was unexpected.

The thicker MCT specimens were machined differently (removed the chevron) than the specimens used to characterize the material. This modification was to reduce curvature during precrack, but curvature was still excessive.

The empirical SINH model has been demonstrated to be an effective vehicle for interpolative life prediction under both simple and complex loading spectra. Its strength lies in its empirical description of observed material behavior (crack propagation) rather than any quasianalytical model of crack tip deformation and hypothesized subsequent effects on crack advance.

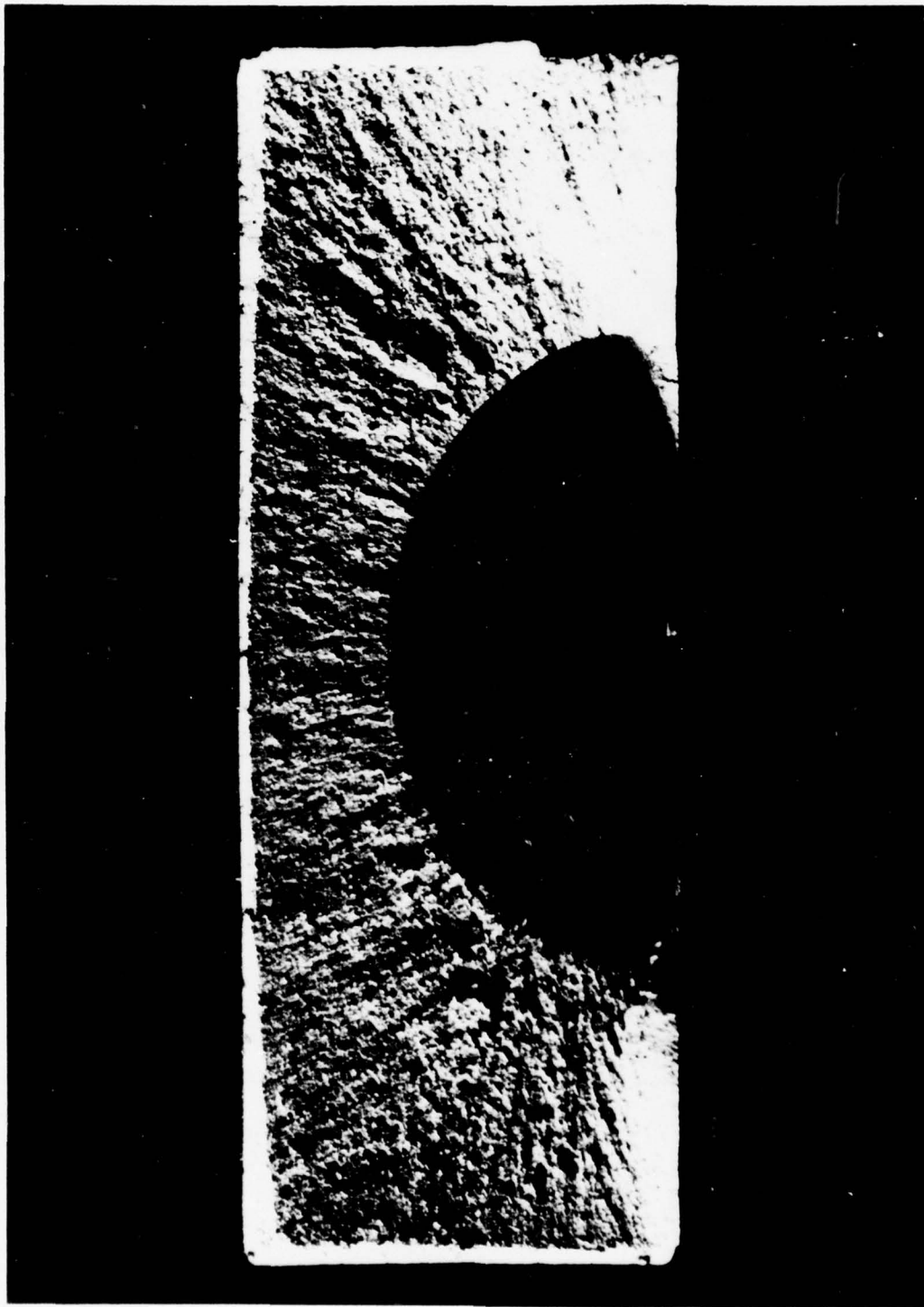

Figure 26. Macrofractograph for 1000°F Surface Flaw Specimen

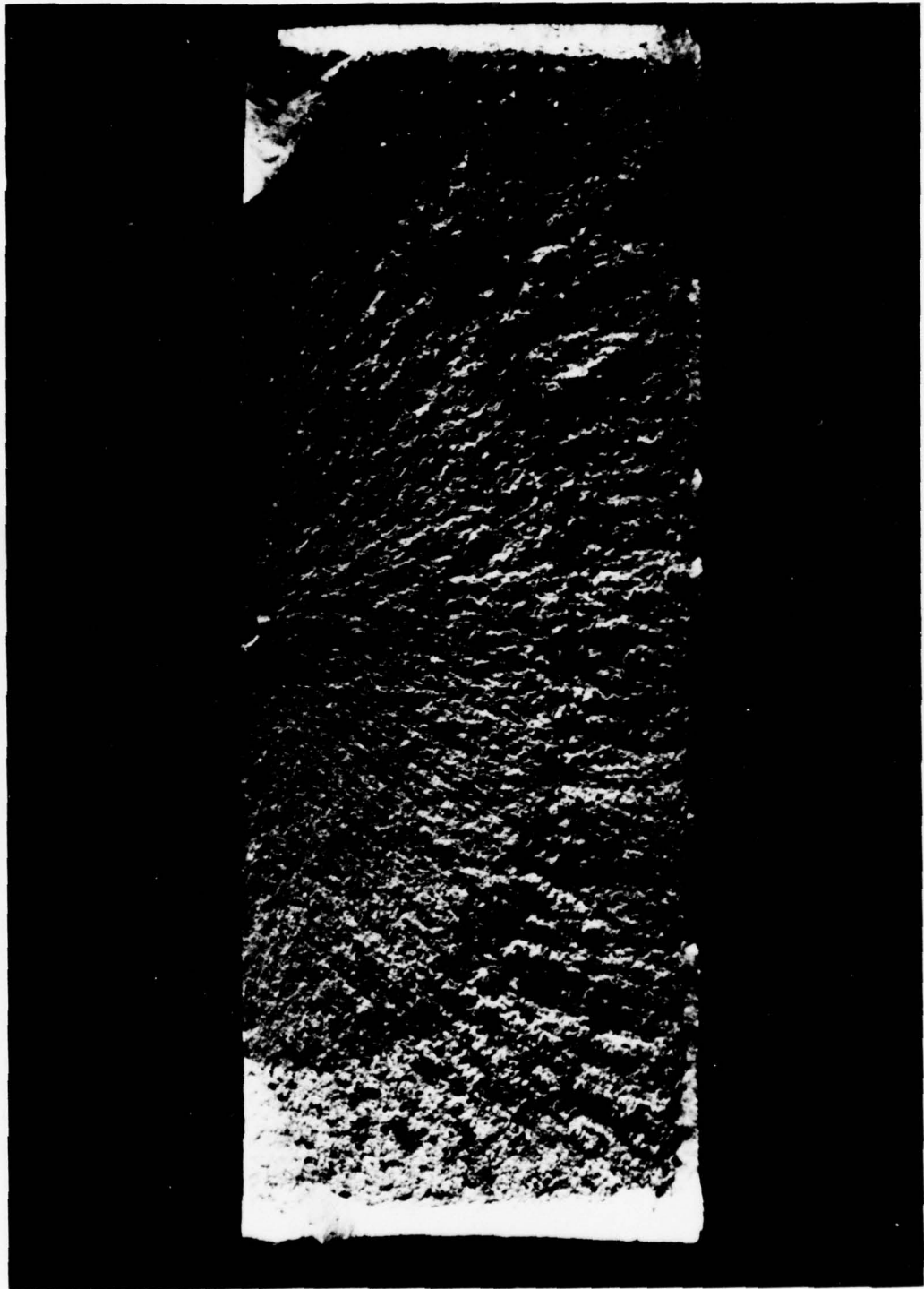

Figure 27. Macrofractograph for 1200°F Surface Flaw Specimen

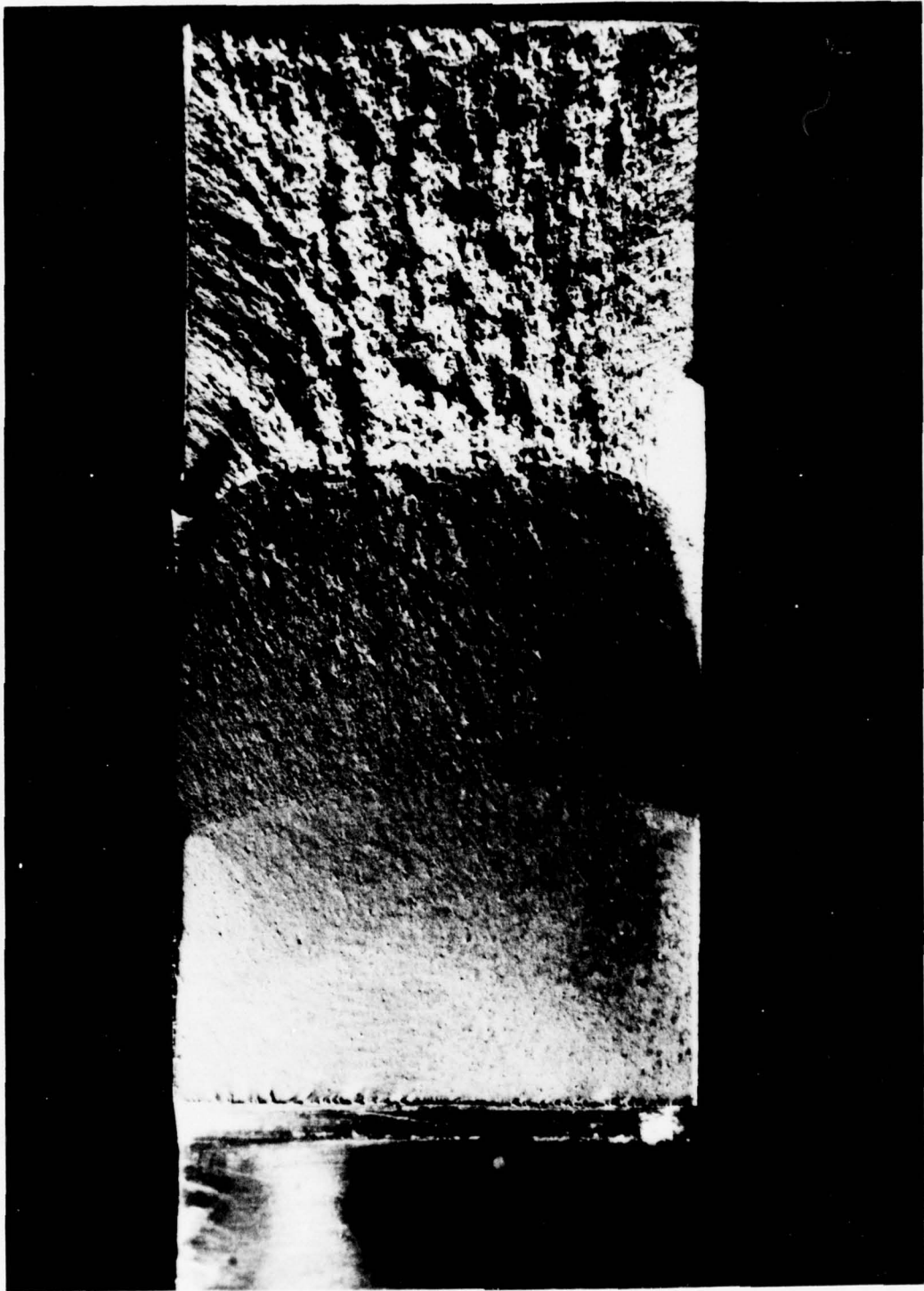

Figure 28. Macrofractograph for 1000°F MCT Specimen

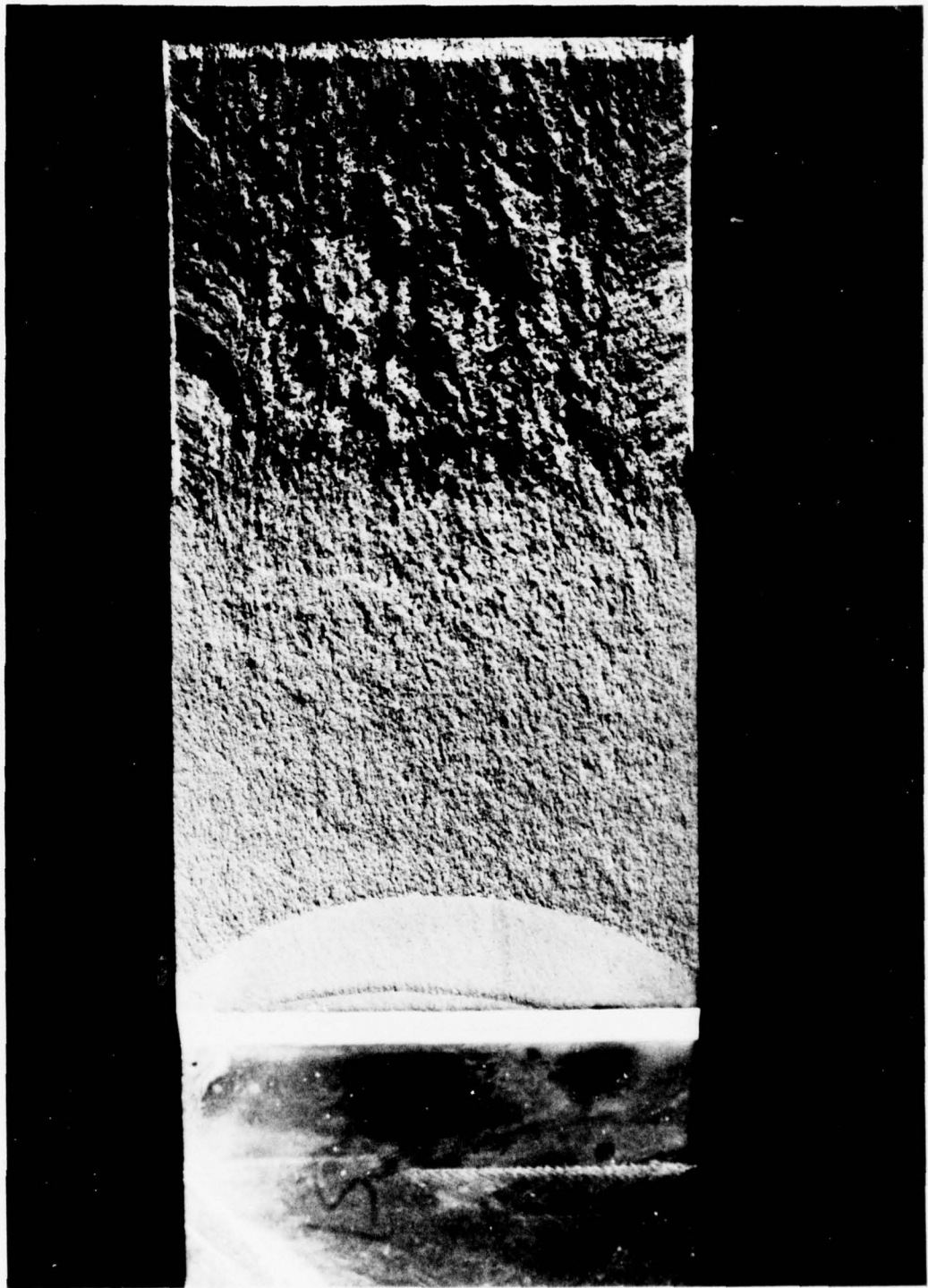

Figure 29. Macrofractograph for 1200°F MCT Specimen

SECTION V CONCLUSIONS

1. The interpolative hyperbolic sine model accurately predicts crack propagation life at elevated temperatures under complex mission spectra.
2. Linear superposition techniques are applicable in IN-100 at temperatures where environmental degradation is minimal (1000°F).
3. Retardation and acceleration in crack growth of IN-100 due to major load excursions should be accounted for at temperatures in the creep regime (1200°F).
4. Further study is required to determine if empirical synergistic models are generally applicable to different component geometries and crack geometries.
5. Lack of time prevented running all four demonstration tests (2 at 1000°F and 2 at 1200°F) at the same load. Table 8 gives a list of starting stress intensity values. A hypothetical comparison is presented in Figure 25.

TABLE 8. STARTING STRESS INTENSITIES

<i>Specimen</i>	<i>Type</i>	<i>Temperature °F</i>	<i>Starting K ksi Inch</i>
650	SF	1200	14
651	SF	1000	15
652	MCT	1000	50
653	MCT	1200	30

REFERENCES

1. Annis, C. G., R. M. Wallace, D. L. Sims, "An Interpolative Model for Elevated Temperature Fatigue Crack Propagation," Air Force Materials Laboratory, AFML-TR-76-176, November 1976.
2. Schijve, J., "Observations on the Prediction of Fatigue Crack Growth Propagation Under Variable-Amplitude Loading," *Fatigue Crack Growth Under Spectrum Loads*, ASTM STP 595, pp. 3-23, 1976.
3. James, L. A., "The Effect of Frequency Upon The Fatigue-Crack Growth of Type 304 Stainless Steel at 1000°F," *Proceedings of 1971 National Symposium on Fracture Mechanics*, Part I, ASTM STP 513, pp. 218-229, 1972.
4. Meyers, G. J., "Design & K-Calibration of Surface Flaw Test Specimen," Pratt & Whitney Aircraft, Commercial Products Division Memo, June 22, 1976.
5. Shah, R. C. and A. S. Kobayashi, "On The Surface Flaw Problem," *The Surface Crack: Physical Problems and Computational Solutions*, New York: The American Society of Mechanical Engineers, 1972.
6. Wallace, R. M., C. G. Annis, and D. L. Sims, "Application of Fracture Mechanics at Elevated Temperatures," Air Force Materials Laboratory AFML-TR-76-176 Part II, November 1976.
7. Wallace, R. M., C. G. Annis, D. L. Sims, "Application of Fracture Mechanics at Elevated Temperatures," Pratt & Whitney Aircraft/Florida FP-7506, March 1976.

APPENDIX A
LIFE ANALYSIS COMPUTER PROGRAM USER INSTRUCTION

This program will predict crack propagation life for MCT specimens and surface flaw specimens with semicircular flaws. To predict crack propagation life of another type specimen, the stress intensity solution would have to replace that of the MCT specimen (if initial crack length is greater than 0.5 in.) or the surface flaw specimen (if initial crack length is less than 0.5 in.). Subroutine life contains the stress intensity solutions and the hyperbolic sine equation that models crack propagation. The sinh equation is:

$$\log (da/dn) = C_1 \sinh (C_2 (\log (\Delta K) + C_3)) + C_4 \quad (A-1)$$

The input data cards must be in order as follows:

- First Card: Card columns 1-72 are for the title. This is in "A" format under the variable name of TITL.
- Second Card: Card columns 1-8 are for the frequency. The designation for frequency (FREQ) should be centered in the first eight card columns for output on the GOULD plot. FREQ is in "A" format.
- Third Card: Card columns 1-8 are for listing the stress ratio for GOULD plot output. The designation for stress ratio (RR) should be centered in the first eight columns. RR is in "A" format.
- Fourth Card: Card columns 1-52 can be used for additional title such as type of analysis. Whatever is input should be centered in the 52 columns in "A" format.
- Fifth Card: Beginning with this card, the NAMELIST parameters are input in the format shown in the sample data set (Appendix C). The input begins with &INPUT, then a blank space. A listing of the parameters and their values is followed by &END which ends the NAMELIST input. Commas separate each parameter value. Table A-1 defines each NAMELIST variable.
- Sixth Card: The actual data is listed next. A maximum of 100 data points may be input. Card columns 1-10 are for the crack length (half crack length for surface flaw specimens) and columns 11-20 are for the number of missions corresponding to the crack length (this cannot be zero). One data point must always be input, the initial crack length and one mission. Both variables use "F" format.
- Seventh Card: A -1.0 is input in card columns 1-10 to separate data sets and allow multiple case analysis.

TABLE A-1
NAMelist VARIABLES

PERIOD:	Normally PERIOD is equal to one for a cyclic portion of a mission, but <i>must be less than one</i> (units in hours) for sustained load portions of a mission. For better accuracy during sustained load portions of a mission, PERIOD should be less than 0.1 hours. To shorten PERIOD, increase NPER (PERIOD * NPER = total length of mission part).
NPER:	Number of cycles or time increments in a mission part.
COEF1:	C_1 in the hyperbolic sine crack propagation equation A-1.
COEF2:	C_2 in the hyperbolic sine equation A-1.
COEF3:	C_3 in the hyperbolic sine equation A-1.
COEF4:	C_4 in the hyperbolic sine equation A-1.
PMAX:	Maximum load for each part of the mission.
RATIO:	Stress Ratio for each part of the mission.
AI:	Initial Crack length.
AF:	Final Crack length at failure (or at the end of stress intensity solution validity).
TEMP:	The temperature to be printed on the GOULD plot.
PKLD:	The maximum load for the whole mission. This is used only for GOULD plot output.
WID:	The width of the surface flaw specimen gage section, or the distance from the MCT load centerline to the end of the specimen.
THIK:	Thickness of the specimen.
LOOPS:	The number of parts into which the mission has been divided.

**APPENDIX B
ACTUAL PROGRAM**

RELEASE 2.C

MAIN

DATE = 76314

16/32/20

```

C     LIPHE.FORT ---- WRITTEN BY D.L. SIMS AND C.G. ANNIS. LATEST      00000C10
C     REVISION 10/29/76. THIS PROGRAM PREDICTS THE LIFE OF MIXED      00000020
C     MISSION SPECIMENS FOR PHASE III OF THE AFML FRACTURE MECHANICS  00000030
C     CONTRACT (MCT AND SURFACE FLAW SPECIMENS ONLY).                 00000040
C                                                                     00000050
C                                                                     00000060
C                                                                     00000070
C     EXAMPLE DATA CARDS ARE AS FOLLOWS                             00000080
C 1  CC-1 TO 72 IS FOR THE TITLE.                                     00000090
C                                                                     00000100
C 2  CC-1 TO 8 IS FOR THE FREQUENCY FOR GOULD PLOT OUTPUT ONLY.      00000110
C                                                                     00000120
C 3  CC-1 TO 8 IS FOR THE STRESS RATIO FOR GOULD PLOT OUTPUT ONLY.   00000130
C                                                                     00000140
C 4  CC-1 TO 52 IS FOR THE TYPE LIFE PREDICTION (SUPERPOSITION, ETC). 00000150
C                                                                     00000160
C 5  NEXT COMES NAMEDLIST DATA (SEVERAL CARDS).                    00000170
C                                                                     00000180
C 6  THE ACTUAL A,N DATA IS LAST (1-100 CARDS).                    00000190
C                                                                     00000200
C 7  -1.C MUST BE PLACED BETWEEN DIFFERENT CASES.                   00000210
C                                                                     00000220
C     DIMENSION A(100), XN(100), CA(100), CN(100), COEF1(20), COEF2(20), 00000230
C     1 COEF3(20), COEF4(20), TITL(18), NPER(20), PERIOD(20),CARD(20),  00000240
C     2 PMAX(20), FREQ(2), RATIO(20), RR(2), TYPE(13)                 00000250
C     DATA A, XN, CA, CN/ 40*0./                                     00000260
C     DATA COEF1, COEF2, COEF3, COEF4, PERIOD, PMAX, NPER/120*0.,20*0/ 00000270
C     DATA RATIO/20*0./                                             00000280
C                                                                     00000290
C     NAMEDLIST /INPUT/COEF1,COEF2,COEF3,COEF4,AI,AF,TEMP,PMAX,      00000300
C 1     WID,THIK,RATIO,NPER,PERIOD,PKLD,LOOPS                          00000310
C                                                                     00000320
C                                                                     00000330
C     WID=WIDTH, THIK=THICKNESS, RATIO=STRESS RATIO, TITL=CC1-72 OF  00000340
C     TITLE CARD, XN=ACTUAL LIFE, COEF1-COEF2-COEF3-COEF4=SINH COEF,  00000350
C     AI=INITIAL CRACK LENGTH, AF=CRITICAL CRACK LENGTH, DA=DELTA CRACK 00000360
C     LENGTH, PMAX=MAX LOAD, A=ACTUAL CRACK LENGTH, CA=CALCULATED CRACK 00000370
C     LENGTH STORED, TA=CALCULATED CRACK LENGTH, CN=CALCULATED LIFE   00000380
C     STORED, TN=CALCULATED LIFE, DKONE=K MAX, DK=DELTA K, PKLD=PEAK  00000390
C     LOAD, FREQ=FREQUENCY, MISN = NUMBER OF MISSIONS, RR = STRESS RATIO 00000400
C     FOR GOULD PRINTOUT ONLY, PERIOD = TIME OR CYCLES IN A MISSION    00000410
C     PART, LOOPS = NUMBER OF PARTS IN THE MISSION, NPER = NUMBER OF   00000420
C     CYCLES OR TIME INCREMENTS IN A MISSION PART. TYPE = TYPE        00000430
C     OF LIFE PREDICTION (SUPERPOSITION, ETC).                         00000440
C                                                                     00000450
C     READ AND WRITE THE COMPLETE DATA SET.                          00000460
C     WRITE(6,59)                                                      00000470
C 59 FORMAT(1H1)                                                        00000480
C 51 READ(5,53,END=55)CARD                                             00000490
C 53 FORMAT(20A4)                                                       00000500
C     WRITE(6,57)CARD                                                  00000510
C 57 FORMAT(1X,20A4)                                                    00000520
C     GO TO 51                                                         00000530
C 55 REWIND 5                                                            00000540
C     WRITE(6,59)                                                       00000550
C                                                                     00000560
C 10 CONTINUE                                                            00000570
C                                                                     00000580

```

```

C      INITIALIZE.                                00000590
      DA=C.                                       00000600
      TN=0.                                       00000610
      NPTS = 0                                    00000620
      MOUNT = 0                                   00000630
      LESTA = 0                                   00000640
      INT = 0                                     00000650
      INCT = 1                                    00000660
C
C      READ AND WRITE THE INDIVIDUAL PARAMETERS.  00000670
      READ(5,1,END=999)TITL                       00000680
      1 FORMAT(18A4)                               00000690
      WRITE(6,59)                                  00000700
      WRITE(6,194) TITL                            00000710
      194 FORMAT(//1X,18A4/)                       00000720
C
C      READ THE FREQUENCY AND STRESS RATIO. FOR OUTPUT ON THE GOULD ONLY. 00000730
      READ(5,4,END=999)FREQ, RR, TYPE             00000740
      4 FORMAT(2A4/2A4/13A4)                      00000750
C
C      READ THE NAMELIST PARAMETERS.              00000760
      READ(5,INPUT,END=999)                       00000770
C
C      READ AND WRITE THE ACTUAL A VS N DATA.    00000780
      WRITE(6,39)                                  00000790
      39 FORMAT(//1X,'ACTUAL A VS N DATA')        00000800
      DO 9 J=1,100                                 00000810
      READ(5,95) A(J), XN(J)                       00000820
      93 FORMAT(2F10.5)                            00000830
      WRITE(6,92) A(J), XN(J)                      00000840
      92 FORMAT(1X,F10.7,4X,F10.1)                 00000850
      IF(A(J) .LE. 0.) GO TO 20                    00000860
      NPTS = NPTS + 1                              00000870
      9 CONTINUE                                   00000880
C
C      WRITE SOME OF THE NAMELIST PARAMETERS.     00000890
      20 WRITE(6,54)                                00000900
      WRITE(6,203)WID,THIK,AI                      00000910
      203 FORMAT(//1X,'WIDTH =',F8.5,6X,'THICKNESS =',F8.5,6X, 00000920
      1'INITIAL CRACK LENGTH =',F8.5)              00000930
C
C      WRITE THE SINH COEFFICIENTS, MAX LOAD AND STRESS RATIO FOR EACH 00000940
      MISSION PART.                               00000950
      WRITE(6,761)                                  00000960
      761 FORMAT(//14X,'SINH COEFFICIENTS',15X,'MAX',6X,'STRESS', 00000970
      13X,'MISSION')                               00000980
      WRITE(6,762)                                  00000990
      762 FORMAT(//6X,'C1',8X,'C2',8X,'C3',8X,'C4',8X,'LOAD',6X,'RATIO',6X, 00001000
      1'PART')                                     00001010
      DO 8 J=1,LOOPS                               00001020
      492 WRITE(6,200)COEF1(J), COEF2(J), COEF3(J), COEF4(J), PMAX(J), 00001030
      1 RATIO(J), J                                00001040
      200 FORMAT(//1X,4F10.5,3X,F8.5,3X,F6.3,6X,13) 00001050
      8 CONTINUE                                   00001060
      WRITE(6,269) LOOPS                           00001070
      269 FORMAT(//1X,'THE MISSION IS BROKEN DOWN INTO',15,3X,'PARTS') 00001080
C

```

```

C      INITIALIZE.                                00001160
C      TA=AI                                       00001170
C      MISN=0                                      00001180
C                                                    00001190
C      CALCULATE THE LIFE - CALL SUBROUTINE LIFE. 00001200
C      SUBROUTINE LIFE DOES THE INTEGRATION CYCLE BY CYCLE. 00001210
C                                                    00001220
C      101 NPART = 1                               00001230
C          DU 155 I=1,LOOPS                         00001240
C**** FIRST PART OF MISSION - 1ST CALL TO LIFE. ***** 00001250
C      CALL LIFE(COEF1(NPART), COEF2(NPART), COEF3(NPART), COEF4(NPART), 00001260
C          1 AF, TA, TN, WID, THK, RATIO(NPART), PMAX(NPART), CA, CN, 00001270
C          2 NPER(NPART), NPART, PERIOD(NPART), MOUNT, MISN, LESTA, INT, INCT, TITL, 00001280
C          3 AI)                                     00001290
C                                                    00001300
C      CHECK IF CRACK IS PAST THE CRITICAL LENGTH. 00001310
C      IF(TA .GE. AF) GO TO 19                      00001320
C                                                    00001330
C      155 CONTINUE                                00001340
C                                                    00001350
C      IF(TA .LT. AF) GO TO 101                    00001360
C                                                    00001370
C      ***                                          00001380
C      CALCULATE PREDICTED LIFE OVER ACTUAL LIFE. 00001390
C      19 Q = MISN/XN(NPTS)                         00001400
C                                                    00001410
C      WRITE OUT THE RESULTS.                      00001420
C      WRITE(6,413) TITL                           00001430
C      413 FORMAT(1H1,IX,16A4)                     00001440
C      WRITE(6,108) TA, TN                          00001450
C      108 FORMAT(1X,'FINAL CRACK LENGTH =',F8.5,5X,'CYCLES TO FAILURE =' 00001460
C          1,F10.1,/)                               00001470
C      WRITE(6,210) XN(NPTS), MISN, Q              00001480
C      210 FORMAT(//1X,'ACTUAL LIFE = ',F7.0,10X,'PREDICTED LIFE = ', 00001490
C          1110//1X,'PREDICTED/ACTUAL = ',F8.5//) 00001500
C                                                    00001510
C      SUBROUTINE CMPAR PLOTS THE PREDICTED VS ACTUAL DATA. 00001520
C      CALL CMPAR(CA, CN, A, XN, NPTS, MOUNT, TITL(3), AI, PKLD, TEMP, 00001530
C          1 RATIO, FREQ, MISN, XN(NPTS), RR, TYPE) 00001540
C                                                    00001550
C      GO TO 10                                     00001560
C      999 STOP                                     00001570
C      END                                          00001580

```

RELEASE 2.0

LIFE

DATE = 76314

16/32/20

```
      SUBROUTINE LIFE(COEF1, COEF2, COEF3, COEF4, AF, TA, TN, WID,
1 THIK, RATIO, PMAX, CA, CN, NPER, NPART, PERIOD, MOUNT, MISN,
2 LESTA, INT, INCT, TITL, AI)
C
C *** CALCULATE LIFE
C DATA D1,D2,D3,D4,D5/ 29.6,-185.5,655.7,-1017.,638.9/
C DATA E1,E2,E3,E4,E5/ 0.5,1.5,2.5,3.5,4.5/
C DIMENSION CA(100), CN(100), TITL(18)
C
C DO THE CYCLE BY CYCLE INTEGRATION.
102 DO 169 I=1,NPER
C
C CHOOSE IF SURFACE FLAW OR MCT SPECIMEN.
C IF(AI .LT. 0.5) GO TO 1333
C
C K-SOLN FOR MCT SPECIMEN.
C AOW=TA/WID
C F=D1*AOW**E1 +D2*AOW**E2 +D3*AOW**E3 +D4*AOW**E4 +D5*AOW**E5
C UKONE=(PMAX/(THIK*SQRT(WID)))*F
C
C GO TO 1334
C
C K-SOLN FOR SURFACE FLAW SPECIMEN.
1333 DKONE=1.2063*PMAX*SQRT(TA)/(WID*THIK)
C
1334 IF(PERIOD .LT. 1.) GO TO 5
C DK=(1.-RATIO)*DKONE
C WRITE(6,2)AOW,F,DKONE,DK
C 2 FORMAT(1X,1P4E12.5)
C GO TO 8
C 5 DK=DKONE
C 6 DADNLG=CDEF1*SINH(COEF2*(ALOG10(DK)+COEF3))*COEF4
C DADN = 10.**DADNLG
C DA = PERIOD * DADN
C TA=TA + DA
C TN=TN + 1.
169 CONTINUE
C
C
C COUNT ONLY THE NUMBER OF MISSIONS.
C IF(NPART .EQ. 1) MISN = MISN + 1
C
C
C WRITE OUT ALL THE JUNK IN THE LOOP.
C IF(INCT .LT. 1) GO TO 1633
C MOUNT=MOUNT+1
C MODULO=MOD(MOUNT,50)
C CA(MOUNT) = TA
C CN(MOUNT) = MISN
C IF(MODULO .NE. 1) GO TO 835
C WRITE(6,413) TITL
C 413 FORMAT(1H1,1X,16A4)
C WRITE(6,414)
C 414 FORMAT(//1X,'CRACK LENGTH',3X,'MISSIONS TO A',7X,'DK',7X,
1'DKMAX',8X,'DA/DN'//)
C 835 WRITE(6,415) TA, MISN, DK, DKONE, DADN
C 415 FORMAT(1X,F9.6,5X,I10,5X,1P3E12.5)
C LESTA = INT
```

00001590
00001600
00001610
00001620
00001630
00001640
00001650
00001660
00001670
00001680
00001690
00001700
00001710
00001720
00001730
00001740
00001750
00001760
00001770
00001780
00001790
00001800
00001810
00001820
00001830
00001840
00001850
00001860
00001870
00001880
00001890
00001900
00001910
00001920
00001930
00001940
00001950
00001960
00001970
00001980
00001990
00002000
00002010
00002020
00002030
00002040
00002050
00002060
00002070
00002080
00002090
00002100
00002110
00002120
00002130
00002140
00002150
00002160

RELEASE 2.0

LIFE

DATE = 76314

16/32/20

1633 INT = IA * 100.
INCT = INT - LESTA
9 NPART = NPART + 1
RETURN
END

00002170
00002180
00002190
00002200
00002210

RELEASE 2.0

CMPAR

DATE = 76314

16/32/20

```
      SUBROUTINE CMPAR(CA, CN, A, XN, NPTS, MOUNT, SPNO, AI, PMAX, 00002220
      1 TEMP, R, FREQ, MISN, ALIFE, RR, TYPE) 00002230
C 00002240
C..... SUBROUTINE CMPAR PLOTS THE ACTUAL VS PREDICTED DATA. 00002250
C 00002260
C 00002270
      DIMENSION CA(100),CN(100),A(100),XN(100),FREQ(2),RR(2),TYPE(13) 00002280
      DATA XCLNTH,NXCYCL, YCLNTH,NYCYCL/1.5, 4, 1., 6/ 00002290
C 00002300
      CALL PLOTS(13.,10.) 00002310
C 00002320
L 00002330
C.....DRAW THE 8.5 BY 11 RECTANGLE. 00002340
      CALL PLOT(0.,10.,2) 00002350
C 00002360
      CALL PLOT(8.5,10.,3) 00002370
C 00002380
      CALL PLOT(8.5,0.,2) 00002390
C 00002400
      CALL PLOT(0.,0.,3) 00002410
C 00002420
C.....CHECKOUT SUBROUTINE GRAPH. 00002430
C 00002440
      CALL PLOT(2.,0.8,-3) 00002450
C 00002460
      CALL DIFFERENT ROUTINE IF SPECIMEN IS A SURFACE FLAW. 00002470
      IF(AI .GT. 0.7) GO TO 26 00002480
      CALL CFGRPH(CA,CN,A,XN,NPTS,MOUNT,SPNO,AI,PMAX,TEMP,R,FREQ,MISN, 00002490
      1 ALIFE,RR,TYPE) 00002500
      GO TO 27 00002510
C 00002520
      26 CALL GRAPH(CA,CN,A,XN,NPTS,MOUNT,SPNO,AI,PMAX,TEMP,R,FREQ,MISN, 00002530
      1 ALIFE,RR,TYPE) 00002540
      27 CALL PLOT(0.,0.,999)
C
      RETURN
      END
```

```

SUBROUTINE GRAPH(CA,CN,A,XN,NPTS,NCALC,SPNO,AI,PMAX,TEMP,R,FREQ, 00002550
1 MISN, ALIFE,KK,TYPE) 00002560
C.....PLOTS CRACK-LENGTH, CYCLES ( A,N ) DATA AND PREDICTION. 00002570
DIMENSION CA(1),CN(1),A(1),XN(1),TYPE(13) 00002580
DIMENSION XNLOG(100),FREQ(2),RR(2) 00002590
DATA XCLNTH,NXCYCL, YCLNTH,NVCYCL/1.5, 4, 1., 6/ 00002600
C 00002610
C.....COMPUTE THE STARTING INTEGER EXPONENT OF TEN. 00002620
C 00002630
MINN=A LOG10( XN(1) ) 00002640
MINCN=A LOG10( CN(1) ) 00002650
MINX=MIN( MINN, MINCN ) 00002660
XMIN=MINX 00002670
C 00002680
C.....DRAW THE LIFE PREDICTION SEMI-LOG GRID. 00002690
CALL LPGRD(XCLNTH,NXCYCL,YCLNTH,NVCYCL,MINX,TYPE) 00002700
C 00002710
C.....PRINT THE SALIENT PARAMETERS. 00002720
CALL PRINT(SPNO,AI,PMAX,TEMP,R,FREQ,MISN,ALIFE,RR) 00002730
C 00002740
C.....TAKE LOGS, COMPUTE THE SCALE PARAMETERS, PLOT DATA AND PREDICTION. 00002750
C 00002760
C.....TAKE LOGS OF X-PARAMETER. 00002770
DO 10 I=1,NPTS 00002780
XNLOG(I) = A LOG10( XN(I) ) 00002790
10 CONTINUE 00002800
C 00002810
C.....PLOT THE DATA. 00002820
XNLOG(NPTS+1)=XMIN 00002830
XNLOG(NPTS+2)=1./XCLNTH 00002840
A(NPTS+1)=0.6 00002850
A(NPTS+2)=0.2/YCLNTH 00002860
CALL LINE(XNLOG,A,NPTS,1,-1,2) 00002870
C 00002880
C.....TAKE LOGS OF X-PARAMETER. 00002890
DO 20 I=1,NCALC 00002900
XNLOG(I) = A LOG10( CN(I) ) 00002910
20 CONTINUE 00002920
C 00002930
C.....DRAW THE PREDICTION. 00002940
XNLOG(NCALC+1)=XMIN 00002950
XNLOG(NCALC+2)=1./XCLNTH 00002960
CA(NCALC+1)=0.6 00002970
CA(NCALC+2)=0.2/YCLNTH 00002980
CALL LINE(XNLOG,CA,NCALC,1,0,0) 00002990
C 00003000
RETURN 00003010
END 00003020

```

```

SUBROUTINE LPGRD(XCLNTH,NXCYCL,YCLNTH,NYCYCL,MINX,TYPE)      00003030
DIMENSION TYPE(13)                                          00003040
C                                                            00003050
C PLOT AND ANNOTATE A SEMI-LOG LIFE PREDICTION GRID.        00003060
C                                                            00003070
DATA H,HQVR2/0.0875, 0.044/                                00003080
HTIM2=H*2                                                    00003090
C                                                            00003100
C DRAW THE GRID                                             00003110
CALL MTGRD2(XCLNTH,NXCYCL,YCLNTH,NYCYCL)                   00003120
C                                                            00003130
C.....DRAW THE Z-SHAPED INTERRUPTION.                       00003140
CALL PLOT(0.,0.2,3)                                         00003150
CALL ERASE(1)                                                00003160
CALL PLOT(0.,0.5,2)                                         00003170
CALL ERASE(0)                                                00003180
CALL PLOT(-0.3,0.35,2)                                       00003190
CALL PLUT(+0.3,0.35,2)                                       00003200
CALL PLUT(0.,0.2,2)                                         00003210
C                                                            00003220
C.....WRITE FIGURE AND TITLE                                00003230
TOP=6.7                                                       00003240
CALL SYMBOL(3.0,(TOP+3.*H),HTIM2,'PEWA MATERIALS AND MECHANICS LAB00003250
LOCATORY',0.,39,1)                                          00003260
CALL SYMBOL(3.0,TOP,HTIM2,'AFML CONTRACT F33615-75-C-5097', 00003270
1 0.,31,1)                                                  00003280
CALL SYMBOL(3.0,(TOP-3.*H),H,'FIGURE ',0.,9,1)             00003290
CALL SYMBOL(3.0,(TOP-5.*H),H,'MODIFIED COMPACT TENSION SPECIMEN PRO0003300
EJECTED CRACK GROWTH',0.,56,1)                             00003310
CALL SYMBOL(3.0,(TOP-7.*H),H,'INTERPOLATIVE HYPERBOLIC SINE MODEL'00003320
1,0.,35,1)                                                  00003330
CALL SYMBOL(3.0,(TOP-9.*H),H,TYPE,0.,52,1)                 00003340
C                                                            00003350
C..... ANNOTATE THE X-AXIS                                  00003360
YLOC=-0.25                                                  00003370
DO 10 I=1,3                                                 00003380
XLOC=I*XCLNTH                                              00003390
CALL NUMBER(XLOC,YLOC,H,10,0.,-1,1)                         00003400
CALL NUMBER((XLOC+HTIM2),(YLOC+H),H,(MINX+I),0.,-1,1)     00003410
10 CONTINUE                                                00003420
C                                                            00003430
C..... ANNOTATE THE Y-AXIS                                  00003440
CALL NUMBER(-0.30,0.,H,0.,0., 1)                            00003450
DO 20 I=1,5                                                 00003460
YLOC=I*YCLNTH - HQVR2                                       00003470
YVAL=0.6+I*0.2                                             00003480
CALL NUMBER(-0.30,YLOC,H,YVAL,0., 1)                        00003490
20 CONTINUE                                                00003500
C                                                            00003510
C..... LABEL THE X-AXIS                                     00003520
CALL SYMBOL(3.0000,-0.6,HTIM2,'TOTAL MISSIONS',0.,14,1)   00003530
C                                                            00003540
C..... LABEL THE Y AXIS                                     00003550
CALL SYMBOL(-0.50,1.5,HTIM2,'CRACK LENGTH, INCHES',90.,20) 00003560
C                                                            00003570
RETURN                                                       00003580
END                                                           00003590

```

```

SUBROUTINE MTGRD2(XCLNTH,NXCYCL,YCLNTH,NYCYCL)
C
C.....GENERATE SEMI-LOG OPEN GRID, X( LOG ) Y, ( CARTESIAN ).
C
  DIMENSION GRID(9),GLNTH(9)
  DATA GRID/ 0.301030, 0.477121, 0.602060, 0.698970, 0.778151,
1          0.845098, 0.903090, 0.954243, 1.0/
  DATA GLNTH/0.100, .160, .205, .235, .265, .285, .305, .325, .340/
  DATA H,HUVR2/0.0875, 0.044/
C
C.....FIND X-AXIS(HORIZONTAL) CYCLE LENGTH AND Y-AXIS(VERTICAL) HIGHT.
  YHIGHT=YCLNTH*NYCYCL
  XLGNTH=XCLNTH*NXCYCL
C
C.....DRAW THE OVERALL X-Y RECTANGLE, WITH ORIGIN AT (0., 0.).
  CALL PLOT(0.,0.,3)
  CALL PLOT(XLGNTH,0.,2)
  CALL PLOT(XLGNTH,YHIGHT,2)
  CALL PLOT(0.,YHIGHT,2)
  CALL PLOT(0.,0.,2)
C
C.....DRAW THE HORIZONTAL GRID LINES.
  NLINES=NYCYCL-1
  DO 10 I=1,NLINES
  YLOC=I*YCLNTH
  CALL PLOT(0.,YLOC,3)
C.....DRAW THE LEFT TIC MARK.
  CALL PLOT(HUVR2,YLOC,2)
C.....DRAW THE DOTTED LINE.
  CALL PLOT((XLGNTH-HUVR2),YLOC,2,1)
C.....DRAW THE RIGHT TIC MARK.
  CALL PLOT(XLGNTH,YLOC,2)
  10 CONTINUE
C
C.....DRAW THE LOGARITHMIC VERTICAL LINES.
  DO 20 NC=1,NXCYCL
  NCM1 = NC-1
  DO 30 I=1,9
  XLOC=(GRID(I)+ NCM1)*XCLNTH
  CALL PLOT(XLOC,0.,3)
  CALL PLOT(XLOC,GLNTH(I),2)
  30 CONTINUE
C.....DRAW THE DOTTED LINE AT EACH COMPLETE CYCLE.
  CALL PLOT(XLOC,(YHIGHT-HUVR2),2,1)
C.....DRAW THE TIC MARK.
  CALL PLOT(XLOC,YHIGHT,2)
  20 CONTINUE
C
  RETURN
  END
00003600
00003610
00003620
00003630
00003640
00003650
00003660
00003670
00003680
00003690
00003700
00003710
00003720
00003730
00003740
00003750
00003760
00003770
00003780
00003790
00003800
00003810
00003820
00003830
00003840
00003850
00003860
00003870
00003880
00003890
00003900
00003910
00003920
00003930
00003940
00003950
00003960
00003970
00003980
00003990
00004000
00004010
00004020
00004030
00004040
00004050
00004060
00004070
00004080
00004090

```

```

SUBROUTINE PRINT(SPND,AI,PMAX,TEMP,R,FREQ,MISN,ALIFE,RR) 00004100
C 00004110
C.....GOULD PRINTS SALIENT PARAMETERS NEXT TO EACH PLOT. 00004120
DIMENSION FREQ(2),KR(2) 00004130
DATA H,HTIM2/0.0875, 0.1750/ 00004140
TWOA = 2.0 * AI 00004150
X1=2.0 00004160
X2=3.00 00004170
X3=3.50 00004180
X4=4.50 00004190
X5=4.00 00004200
Y=7.5 00004210
CALL SYMBOL(X1,Y,H,'SPECIMEN NUMBER',C.,15,1) 00004220
CALL SYMBOL(X2,Y,H,SPND,0.,4,1) 00004230
C 00004240
C CHECK IF MCT SPECIMEN OR SURFACE FLAW SPECIMEN. 00004250
IF(AI .LT. 0.5) GO TO 58 00004260
CALL SYMBOL(X3,Y,H,'MCT SPECIMEN',0.,12) 00004270
GO TO 68 00004280
C 00004290
58 CALL SYMBOL(X3,Y,H,'SURFACE FLAW',0.,12) 00004300
68 Y=Y-HTIM2 00004310
CALL SYMBOL(X1,Y,H,'INITIAL CRACK',0.,13,1) 00004320
IF(AI .GT. 0.5) GO TO 56 00004330
CALL NUMBER(X2,Y,H,TWOA,0.,3,1) 00004340
GO TO 57 00004350
56 CALL NUMBER(X2,Y,H,AI,C.,3,1) 00004360
57 CALL SYMBOL(X3,Y,H,'INCHES',0.,6) 00004370
Y=Y-HTIM2 00004380
CALL SYMBOL(X1,Y,H,'MAX LOAD',0.,8,1) 00004390
CALL NUMBER(X2,Y,H,PMAX,0.,3,1) 00004400
CALL SYMBOL(X3,Y,H,'KIPS',0.,4) 00004410
Y=Y-HTIM2 00004420
CALL SYMBOL(X1,Y,H,'TEMPERATURE',0.,11,1) 00004430
CALL NUMBER(X2,Y,H,TEMP,0.,-1,1) 00004440
CALL SYMBOL(X3,Y,H,'DEGREES F',0.,9) 00004450
Y=Y-HTIM2 00004460
CALL SYMBOL(X1,Y,H,'STRESS RATIO',0.,12,1) 00004470
CALL SYMBOL(X2,Y,H,RR,C.,8,1) 00004480
Y=Y-HTIM2 00004490
CALL SYMBOL(X1,Y,H,'FREQUENCY',C.,9,1) 00004500
CALL SYMBOL(X2,Y,H,FREQ,0.,8,1) 00004510
CALL SYMBOL(X3,Y,H,'MISSION',0.,7) 00004520
Y=Y-HTIM2 00004530
Y=Y-HTIM2 00004540
CALL SYMBOL(X1,(Y+0.025),H,2,C.,-1,1) 00004550
CALL SYMBOL(X2,Y,H,'ACTUAL DATA',0.,11,1) 00004560
CALL NUMBER(X5,Y,H,ALIFE,0.,-1,1) 00004570
CALL SYMBOL(X4,Y,H,'MISSIONS',0.,8) 00004580
Y=Y-HTIM2 00004590
CALL PLOT(1.75,Y,3) 00004600
CALL PLOT(2.25,Y,2,-1) 00004610
CALL SYMBOL(X2,Y,H,'PREDICTED',C.,9,1) 00004620
CALL NUMBER(X5,Y,H,MISN,C.,-1,1) 00004630
CALL SYMBOL(X4,Y,H,'MISSIONS',0.,8) 00004640
RETURN 00004650
END 00004660

```

```

SUBROUTINE CFGRPH(CA,CN,A,XN,NPTS,NCALC,SPNO,AI,PMAX,TEMP,R,FREQ, 00004670
1 MISN, ALIFE, RR, TYPE) 00004680
C.....PLOTS CRACK-LENGTH, CYCLES ( A,N ) DATA AND PREDICTION. 00004690
DIMENSION CA(1),CN(1),A(1),XN(1),TYPE(13) 00004700
DIMENSION XNLOG(100),FREQ(2),RR(2) 00004710
DATA XCLNTH,NXCYCL, YCLNTH,NYCYCL/1.5, 4, 1., 6/ 00004720
C 00004730
C.....COMPUTE THE STARTING INTEGER EXPONENT OF TEN. 00004740
C 00004750
MINN=ALOG10( XN(1) ) 00004760
MINCN=ALOG10( CN(1) ) 00004770
MINX=MIN( MINN, MINCN ) 00004780
XMIN=MINX 00004790
C 00004800
C.....DRAW THE LIFE PREDICTION SEMI-LOG GRID. 00004810
CALL CFGRD(XCLNTH,NXCYCL,YCLNTH,NYCYCL,MINX,TYPE) 00004820
C 00004830
C.....PRINT THE SALIENT PARAMETERS. 00004840
CALL PRINT(SPNO,AI,PMAX,TEMP,R,FREQ,MISN,ALIFE,RR) 00004850
C 00004860
C.....TAKE LOGS, COMPUTE THE SCALE PARAMETERS, PLOT DATA AND PREDICTION. 00004870
C 00004880
C.....TAKE LOGS OF X-PARAMETER. 00004890
DO 10 I=1,NPTS 00004900
XNLOG(I) = ALOG10( XN(I) ) 00004910
10 CONTINUE 00004920
C 00004930
C.....PLOT THE DATA. 00004940
XNLOG(NPTS+1)=XMIN 00004950
XNLOG(NPTS+2)=1./XCLNTH 00004960
A(NPTS+1)=0.0 00004970
A(NPTS+2)=0.1/YCLNTH 00004980
CALL LINE(XNLOG,A,NPTS,1,-1,2) 00004990
C 00005000
C.....TAKE LOGS OF X-PARAMETER. 00005010
DO 20 I=1,NCALC 00005020
XNLOG(I) = ALOG10( CN(I) ) 00005030
20 CONTINUE 00005040
C 00005050
C.....DRAW THE PREDICTION. 00005060
XNLOG(NCALC+1)=XMIN 00005070
XNLOG(NCALC+2)=1./XCLNTH 00005080
CA(NCALC+1)=0.0 00005090
CA(NCALC+2)=0.1/YCLNTH 00005100
CALL LINE(XNLOG,CA,NCALC,1,0,0) 00005110
C 00005120
RETURN 00005130
END 00005140

```

```

SUBROUTINE CFGRD(XCLNTH,NXCYCL,YCLNTH,NYCYCL,MINX,TYPE)          00005150
DIMENSION TYPE(13)                                             00005160
C                                                                00005170
C PLOT AND ANNOTATE A SEMI-LOG LIFE PREDICTION GRID.          00005180
C                                                                00005190
DATA H,HQVR2/0.0875, 0.044/                                    00005200
HTIM2=H*2                                                       00005210
C                                                                00005220
C DRAW THE GRID                                               00005230
CALL MTGRD2(XCLNTH,NXCYCL,YCLNTH,NYCYCL)                       00005240
C                                                                00005250
C.....DRAW THE Z-SHAPED INTERRUPTION.                         00005260
C CALL PLOT(C.,C.2,3)                                          00005270
C CALL ERASE(1)                                                00005280
C CALL PLOT(C.,0.5,2)                                          00005290
C CALL ERASE(C)                                                00005300
C CALL PLOT(-0.3,0.35,2)                                       00005310
C CALL PLOT(+0.3,0.35,2)                                       00005320
C CALL PLOT(0.,0.2,2)                                          00005330
C                                                                00005340
C.....WRITE FIGURE AND TITLE                                  00005350
TOP=8.7                                                         00005360
CALL SYMBOL(3.0,(TOP+3.*H),HTIM2,'PEWA MATERIALS AND MECHANICS LAB 00005370
ORATORY',C.,39,1)                                             00005380
CALL SYMBOL(3.0,TOP,HTIM2,'AFML CONTRACT F33615-75-C-5097', 00005390
1 0.,31,1)                                                    00005400
CALL SYMBOL(3.0,(TOP-3.*H),H,'FIGURE ',C.,9,1)                00005410
CALL SYMBOL(3.0,(TOP-5.*H),H,'SURFACE FLAW SPECIMEN CRACK GROWTH P00005420
REDICTION',0.,45,1)                                          00005430
CALL SYMBOL(3.0,(TOP-7.*H),H,'INTERPOLATIVE HYPERBOLIC SINE MODEL'00005440
1,0.,35,1)                                                    00005450
CALL SYMBOL(3.0,(TOP-9.*H),H,TYPE,C.,52,1)                   00005460
C                                                                00005470
C..... ANNOTATE THE X-AXIS                                    00005480
YLOC=-0.25                                                      00005490
DO 10 I=1,3                                                     00005500
XLOC=I*XCLNTH                                                  00005510
CALL NUMBER(XLOC,YLOC,H,10,0.,-1,1)                            00005520
CALL NUMBER((XLOC+HTIM2),(YLOC+H),H,(MINX+I),0.,-1,1)        00005530
10 CONTINUE                                                    00005540
C                                                                00005550
C.....ANNOTATE THE Y-AXIS                                    00005560
CALL NUMBER(-0.30,0.,H,0.,0., 1)                               00005570
DO 20 I=1,5                                                     00005580
YLOC=I*YCLNTH - HQVR2                                         00005590
YVAL=I*0.1                                                     00005600
CALL NUMBER(-0.30,YLOC,H,YVAL,C., 1)                          00005610
20 CONTINUE                                                    00005620
C                                                                00005630
C.....LABEL THE X-AXIS                                        00005640
CALL SYMBOL(3.0G00,-0.0,HTIM2,'TOTAL MISSIONS',0.,14,1)     00005650
C                                                                00005660
C.....LABEL THE Y AXIS                                       00005670
CALL SYMBOL(-0.50,1.0,HTIM2,'HALF CRACK LENGTH, INCHES',90.,25)00005680
C                                                                00005690
RETURN                                                         00005700
END                                                             00005710

```

**APPENDIX C
SAMPLE INPUT DATA**

```

SPECIMEN 653 MCT SPECIMEN FOR AFML FRACTURE MECHANICS.
LUKE CENTER FREQUENCY IN THE FIRST 8 SPACES OF THIS LINE.
MIXED CENTER STRESS RATIO IN THE FIRST 8 SPACES OF THIS LINE.
RETARDATION MODEL CENTER IN 52 SPACES.
&INPUT PERIOD = 1., .0333, 1., .0350, 0.0136, 1., .0350, .0285,
          1., .0333,
NPER = 1, 1, 1, 1, 1, 7, 1, 3,
        1, 1,
COEF1 = 0.500, 0.500, 0.500, 0.500, 0.500, 0.500, 0.500, 0.500,
        0.500, 0.500,
COEF2 = 3.938, 4.297, 4.110, 4.378, 4.297, 4.169, 4.292, 4.297,
        4.116, 4.297,
COEF3 = -1.397, -1.479, -1.305, -1.633, -1.479, -1.277, -1.565, -1.479,
        -1.305, -1.479,
COEF4 = -4.156, -2.519, -4.241, -2.998, -2.519, -4.267, -2.807, -2.519,
        -4.241, -2.519,
PMAX = 2.760, 2.760, 6.000, 4.680, 4.680, 5.340, 4.680, 4.680,
        6.000, 2.760,
RATIO = 0.2, 1.0, 0.46, 1.0, 1.0, 0.52, 1.0, 1.0,
        0.46, 1.0,
AI = 1.00830, AF = 1.7500, TEMP = 1200., PKLD = 6.0,
WID = 2.5090, THIK = 0.8510,
LOOPS = 10,

&END
1.0083 1.
1.0097 5.
1.0235 17.
1.0344 29.
1.0429 41.
1.0465 51.
1.0562 61.
1.0606 71.
1.0639 81.
1.0704 91.
1.0773 101.
1.0811 111.
1.0859 120.
1.0933 129.
1.0997 138.
1.1026 147.
1.1153 170.
1.1266 193.
1.1465 230.
1.1640 260.
1.1797 290.
1.1965 319.
1.2125 348.
1.2328 384.
1.2692 440.
1.2873 470.
1.3074 500.
1.3281 530.
1.3544 560.
1.3769 590.
1.3992 617.
1.4292 650.
1.4795 682.
1.4810 699.
1.5152 721.
1.5394 742.

```

1.5734	758.
1.5997	770.
1.6173	781.
1.6401	790.
1.6575	799.
1.6890	808.
1.7175	815.
-1.0	