

AD-A044 444

01.122

TECHNICAL LIBRARY
DARCOM Field Safety Activity

Final Technical Report

TNT EQUIVALENCY OF BLACK POWDER
Volume II: Appendices

July 1972

IITRI Report No. J6265-3

Prepared By:

Hyla S. Napadensky
James J. Swatosh, Jr.

IIT Research Institute
10 W. 35th Street
Chicago, Illinois 60616

Under the technical direction of
Manufacturing Technology Directorate
Picatinny Arsenal

CONTENTS

		<u>Page</u>
APPENDIX A	Pressure-Impulse Data	A-1
APPENDIX B	TNT Equivalency Calculation Procedure	B-1
APPENDIX C	Computed Values of Pressure and Impulse Equivalencies	C-1
APPENDIX D	Instrumentation	D-1
APPENDIX E	Data Point Equivalencies	E-1

APPENDIX A

MEASURED PRESSURE-IMPULSE DATA

APPENDIX A
MEASURED PRESSURE-IMPULSE DATA

CONTENTS

		<u>Page</u>
A.1	General	A-1

TABLES

A.1	Test Data, Booster Tests (BO-)	A-2
A.2	Test Data, Unconfined Tests (UNC-)	A-10
A.3	Test Data, Confined Tests (CON-)	A-11
A.4	Test Data, Squib Tests (SQ-)	A-13

FIGURES

A.1-A.31	Pressure and Impulse, Booster Series Tests (BO-)	A-14
A.32-A.36	Pressure and Impulse, Unconfined Tests (UNC-)	A-46
A.37-A.41	Pressure and Impulse Confined Tests (CON-)	A-51
A.42-A.47	Pressure and Impulse, Squib Initiated Tests (SQ-)	A-56

A.1 GENERAL

The measured peak pressures, P; impulse, I, and radial distance, R; for the tests described in Volume I are presented in tabular and graphical form. The scaled distances and scaled impulses shown for the data points are based on total charge weight, and have not been adjusted to take into account the weight of the booster explosive.

TABLE A.1
TEST DATA

R P I
(FT) (PSIG) (PSI-MS)

25 LB. BLACK POWDER, .25 LB. 120 DEG. CONE C4 BOOSTER BO 5,6

6.00	32.30	27.60
8.98	13.30	15.60
12.79	8.70	11.80
17.75	5.06	8.77
22.63	3.86	7.40
46.71	1.31	3.22
6.00	32.30	26.90
8.98	13.65	16.60
12.79	9.03	12.50
17.75	5.34	9.20
22.63	3.77	8.06
46.71	1.25	3.76

25 LB. BLACK POWDER, .50 LB. 120 DEG. CONE C4 BOOSTER BO 8,9

6.00	43.10	41.60
8.98	19.60	22.20
12.79	12.40	16.10
17.75	7.32	12.00
22.63	5.11	10.30
46.71	1.49	4.67
6.00	46.30	43.60
8.98	19.90	23.50
12.79	12.50	17.20
17.75	5.43	12.80
22.63	4.75	10.40
46.71	1.58	4.88

25 LB. BLACK POWDER, .50 LB. CYLINDRICAL BOOSTER BO 13,12

6.00	53.80	45.60
8.98	22.60	23.40
12.79	12.55	17.20
17.75	7.45	12.80
22.63	4.90	10.85
46.71	1.56	4.96
8.98	20.20	28.00
12.79	10.30	16.15
17.75	6.35	13.20
22.63	4.27	11.20
46.71	1.48	4.25

TABLE A.1
TEST DATA

R P I
(FT) (PSIG) (PSI-MS)

27 LB. BLACK POWDER, .024 LB. TETRYL CYLINDRICAL BOOSTER, BO 14,15 S.P.

4.00	16.90	23.00
6.98	9.30	13.40
10.79	5.56	8.55
15.75	3.54	6.05
20.63	2.31	4.76
44.71	.78	2.20
4.00	18.10	24.30
6.98	8.85	12.90
10.79	5.36	8.55
15.75	3.16	6.25
20.63	2.11	4.62
44.71	.74	2.09

75 LB. BLACK POWDER, .50 LB. C4 CYLINDRICAL BOOSTER, BO 16,18

9.00	37.00	46.50
15.79	12.50	23.90
20.75	8.16	13.50
25.63	5.85	16.80
49.71	2.14	8.70
11.98	19.25	31.60
15.79	14.40	25.00
20.75	8.95	13.90
25.63	6.42	16.35
49.71	2.12	8.14

75 LB. BLACK POWDER, .50 LB. C4 CYLINDRICAL BOOSTER, BO 17,19 S.P.

9.00	45.50	55.00
15.79	14.40	25.20
20.75	9.25	20.25
25.63	5.96	16.80
49.71	2.27	7.95
9.00	44.60	50.90
15.79	13.20	25.80
20.75	8.70	20.50
25.63	6.76	17.80
49.71	2.29	9.19

TABLE A.1
TEST DATA

R P I
(FT) (PSIG) (PSI-MS)

75 LB. BLACK POWDER, 1.0 LB. C4 CYLINDRICAL BOOSTER, 80 20,21

9.00	69.40	77.40
15.79	19.00	32.20
20.75	13.10	25.40
25.63	3.35	22.80
49.71	2.56	10.40
9.00	62.00	73.10
15.79	13.60	32.60
20.75	12.20	24.60
25.63	8.20	21.80
49.71	2.56	10.45

75 LB. BLACK POWDER, 1.5 LB. C4 CYLINDRICAL BOOSTER, 80 30,31 S.P.

12.00	35.60	55.20
14.98	23.90	34.80
18.79	17.05	31.80
23.75	10.12	22.50
28.63	8.36	22.50
52.71	2.59	11.60
14.98	23.90	37.60
18.79	15.85	28.80
23.75	10.95	22.30
28.63	7.40	20.50
52.71	2.42	11.20

25 LB. BLACK POWDER, 1.0 LB. C4 CYLINDRICAL BOOSTER, 80 32,33 S.P.

6.00	74.50	58.30
8.98	39.40	38.60
12.79	21.10	24.60
17.75	11.30	17.10
22.63	7.37	14.85
46.71	1.98	6.85
6.00	38.60	61.00
8.98	33.50	39.70
12.79	18.10	24.90
17.75	11.75	16.50
22.63	7.05	14.50
46.71	1.92	6.82

TABLE A.1
TEST DATA

R P I
(FT) (PSIG) (PSI-MS)

25 LB. BLACK POWDER, 0.54 LB. PBX CYLINDRICAL BOOSTER, 80 36,37 S.P.

6.00	62.60	51.60
8.98	32.20	28.20
12.79	14.80	20.60
17.75	8.59	14.40
22.63	5.86	12.10
46.71	1.61	5.66
6.00	63.00	57.80
8.98	29.20	28.40
12.79	15.45	25.60
17.75	8.66	14.30
22.63	5.46	11.60
46.71	1.52	5.45

150 LB. BLACK POWDER, 1.5 LB. C4 CYLINDRICAL BOOSTER 80 40, S.P.

12.00	43.70	80.40
14.98	28.40	49.20
18.79	18.35	39.70
23.75	14.40	31.20
28.63	10.50	32.20
52.71	3.30	17.90

150 LB. BLACK POWDER, 3.0 LB. C4 CYLINDRICAL BOOSTER 80 41,42 S.P.

12.00	63.00	95.20
14.98	41.40	66.50
18.79	25.80	57.50
23.75	19.95	40.40
28.63	13.30	33.20
52.71	3.99	17.60
12.00	61.50	110.50
14.98	37.50	73.10
18.79	23.60	47.00
23.75	19.00	37.70
28.63	11.60	33.40
52.71	3.74	17.30

TABLE A.1
TEST DATA

	R	P	I
	(FT)	(PSIG)	(PSI-MS)
25 LB. SAND, .25 -B. 120 DEG. CONE C4 BOOSTER B0 1,2			
	6.00	3.59	2.54
	8.98	1.75	1.20
	12.79	1.20	.77
	17.75	.76	.49
	22.63	.52	.50
	46.71	.21	.25
	6.00	3.66	1.82
	8.98	1.71	1.10
	12.79	1.05	.74
	17.75	.70	.50
	22.63	.50	.40
	46.71	.19	.20
25 LB. SAND, .50 -B. 120 DEG. CONE C4 BOOSTER B0 3,4			
	6.00	6.25	3.56
	8.98	2.55	1.98
	12.79	1.35	1.93
	17.75	.95	.94
	22.63	.64	.74
	46.71	.24	.34
	6.00	8.65	4.70
	8.98	3.25	2.46
	12.79	1.82	1.62
	17.75	1.16	1.19
	22.63	.73	1.00
	46.71	.32	.41
25 LB. SAND, .50 -B. CYLINDRICAL C4 BOOSTER B0 10,11			
	6.00	6.19	7.46
	8.98	2.90	4.38
	12.79	1.80	2.93
	17.75	1.27	1.82
	22.63	.92	.98
	46.71	.36	.67
	6.00	4.26	3.24
	8.98	2.12	1.91
	12.79	1.28	1.09
	17.75	.90	.78
	22.63	.72	.63
	46.71	.29	.56

TABLE A.1
TEST DATA

R	P	I
(FT)	(PSIG)	(PSI-MS)
25 LB. SAND, 1.0 LB. CYLINDRICAL C4 BOOSTER B0 22,23,24 STEEL PLATE		
9.00	3.12	5.23
11.98	2.12	3.64
15.79	1.55	2.63
20.75	1.13	1.99
25.63	.91	1.56
49.71	.42	.65
9.00	5.04	5.99
11.98	2.76	3.64
15.79	1.93	2.90
20.75	1.37	2.03
25.63	.96	1.62
49.71	.47	.75
9.00	3.78	6.91
11.98	2.68	3.88
15.79	1.75	2.87
20.75	1.13	2.07
25.63	.86	1.67
49.71	.42	.81
25 LB. SAND, .50 LB. CYLINDRICAL C4 BOOSTER B0 25,26 STEEL PLATE		
9.00	1.66	2.04
11.98	1.10	1.23
15.79	.80	.90
20.75	.61	.71
25.63	.45	.60
49.71	.25	.33
9.00	2.42	1.47
11.98	1.56	1.38
15.79	1.35	1.25
20.75	.84	.92
25.63	.63	.84
49.71	.25	.39

TABLE A.1
TEST DATA

R P I
(FT) (PSIG) (PSI-MS)

25 LB. SAND, 1.5 LB. CYLINDRICAL C4 BOOSTER BO 27,28,29 STEEL PLATE

12.00	4.16	8.78
14.98	2.60	5.40
18.79	1.94	4.48
23.75	1.53	3.29
28.63	1.12	2.88
52.71	.62	1.36
12.00	5.15	8.30
14.98	3.15	5.31
18.79	2.38	4.16
23.75	1.77	3.09
28.63	1.44	2.74
52.71	.64	1.40
12.00	5.21	8.81
14.98	2.71	5.42
18.79	1.99	4.86
23.75	1.27	3.19
28.63	1.06	2.85
52.71	.48	1.45

25 LB. SAND, .54 LB. PBX CYLINDRICAL BOOSTER BO 34,35 STEEL PLATE

6.00	6.45	6.34
8.98	3.04	3.65
12.79	1.84	2.49
17.75	1.11	1.70
22.63	.83	1.37
46.71	.35	.65
6.00	7.06	6.82
8.98	3.12	4.26
12.79	2.03	2.88
17.75	1.35	1.84
22.63	.87	1.49
46.71	.32	.37

150 LB. SAND, 3.0 LB. CYLINDRICAL C4 BOOSTER BO 38,39 STEEL PLATE

12.00	5.96	.00
14.98	3.68	.00
18.79	2.00	.00
23.75	1.98	.00
28.63	1.41	.00
52.71	.75	.00
12.00	5.70	15.10
14.98	3.42	9.15
18.79	2.63	6.95
23.75	1.68	4.88
28.63	1.35	4.38
52.71	.71	2.04

TABLE A.1
TEST DATA

R P I
(FT) (PSIG) (PSI-MS)

25 LB, SAND,	.53 LB.	CYLINDRICAL C4 BOOSTER B0 43	STEEL PLATE
6.00	3.33	6.89	
8.98	1.81	3.77	
12.79	1.25	2.39	
17.75	.73	1.58	
22.63	.57	1.26	
46.71	.20	.59	

TABLE A.2
TEST DATA

R P I
(FT) (PSIG) (PSI-MS)

27 LB. BLACK POWDER, .024 LB. CYLINDRICAL TETRYL BOOSTER, UNC 1,2 STAND OFF

4.00	4.57	3.60
6.98	2.33	2.13
10.79	1.40	1.35
15.75	.89	.99
20.63	.68	.81
44.71	.32	.36

64 LB. BLACK POWDER, .024 LB. CYLINDRICAL TETRYL BOOSTER, UNC 4 STAND OFF

4.00	4.04	2.66
6.98	1.91	1.56
10.79	1.32	.96
15.25	.90	.72
20.63	.66	.62
44.71	.28	.25

27 LB. BLACK POWDER, .024 LB. CYLINDRICAL TETRYL BOOSTER, UNC 5

4.00	13.80	19.90
6.98	6.84	10.70
10.79	4.05	7.35
15.75	2.56	4.99
44.71	1.57	3.13

140 LB. BLACK POWDER, .024 LB. CYLINDRICAL TETRYL BOOSTER UNC 6

7.50	16.60	58.10
10.48	11.00	43.50
14.29	8.45	26.30
19.25	7.35	25.30
24.13	7.06	20.60
48.21	2.45	10.40

27 LB. JET MILL PRODUCT, .024 LB. CYLINDRICAL TETRYL BOOSTER UNC 9

4.00	3.92	18.60
6.98	2.20	10.10
10.79	1.43	6.50
15.75	1.00	4.79
20.63	.73	4.08
44.71	.27	1.58

TABLE A.3
TEST DATA

R P I
(FT) (PSIG) (PSI-MS)

8 LB. BLACK POWDER, .024 LB. CYLINDRICAL TETRYL BOOSTER CON 1,2

15.59	4.68	5.80
20.55	3.11	4.71
25.43	2.32	4.72
49.51	.93	2.14
4.00	17.40	24.40
6.98	11.30	13.10
10.79	6.64	9.07
44.71	1.05	2.72

27 LB. BLACK POWDER, .024 LB. CYLINDRICAL TETRYL BOOSTER CON 3,4,5

7.50	28.90	32.20
10.48	14.60	20.00
14.29	10.10	15.60
19.25	6.71	12.10
24.13	4.70	10.70
48.21	1.54	5.30
7.50	23.00	28.90
10.48	12.40	18.20
14.29	8.45	13.80
19.25	5.55	10.40
24.13	4.07	9.12
48.21	2.04	4.36
7.50	23.70	32.20
10.48	14.10	20.20
14.29	9.31	15.00
19.25	5.79	11.30
24.13	4.37	9.67
48.21	1.46	4.42

TABLE A.3
TEST DATA

R P I
(FT) (PSIG) (PSI-MS)

64 LB. BLACK POWDER, .024 LB. CYLINDRICAL TETRYL BOOSTER CON 6,7,8

7.50	41.00	58.60
10.48	24.60	38.70
14.29	19.00	30.00
19.25	12.00	24.20
24.13	8.21	19.80
48.21	2.91	10.10
7.50	43.40	58.10
10.48	25.80	36.10
14.29	14.60	28.60
19.25	12.40	23.00
24.13	8.39	26.60
48.21	2.51	11.00
7.50	42.90	52.70
10.48	25.90	36.80
14.29	19.20	29.10
19.25	12.30	22.80
24.13	7.80	19.30
48.21	2.46	10.70

140 LB. BLACK POWDER, .024 LB. CYLINDRICAL TETRYL BOOSTER CON 9,10

8.50	74.40	83.60
15.29	33.80	61.20
20.25	25.30	45.10
25.13	16.10	39.30
49.21	4.41	19.20
8.50	89.80	89.80
15.29	30.00	57.50
20.25	22.60	45.70
25.13	16.00	36.30
49.21	4.09	19.20

27 LB. JET MILL PRODUCT, .024LB. CYLINDRICAL TETRYL BOOSTER CON 11,12

7.50	9.93	13.50
10.48	5.77	10.40
14.29	4.14	8.28
19.25	2.88	6.15
24.13	2.20	5.85
48.21	.94	3.39
7.50	11.70	18.70
10.48	6.65	17.90
14.29	4.61	10.20
19.25	3.41	8.26
24.13	2.57	7.12
48.21	1.13	3.44

TABLE A.4
TEST DATA

R	P	I
(FT)	(PSIG)	(PSI-MS)

27 LB. BLACK POWDER SQUIB IGNITION SQ 1,2,3

7.50	20.20	22.30
10.48	11.60	14.40
14.29	6.76	10.90
19.25	4.58	8.05
24.13	4.33	7.35
48.21	1.25	3.88
7.50	18.60	21.10
10.48	10.00	13.20
14.29	6.48	9.47
19.25	4.52	7.83
24.13	3.32	6.50
48.21	1.18	3.50
7.50	16.80	20.70
10.48	10.20	12.70
14.29	6.60	9.37
19.25	4.05	7.68
24.13	3.08	6.83
48.21	1.11	3.28

27 LB. JET MILL PRODUCT, SQUIB IGNITION SQ 4,5

7.50	15.40	25.18
10.48	8.40	17.65
14.29	6.32	14.17
19.25	5.01	11.00
24.13	3.79	9.60
48.21	1.45	5.05
7.50	14.60	26.30
10.48	10.80	18.30
14.29	7.34	14.60
19.25	5.03	11.60
24.13	3.66	12.00

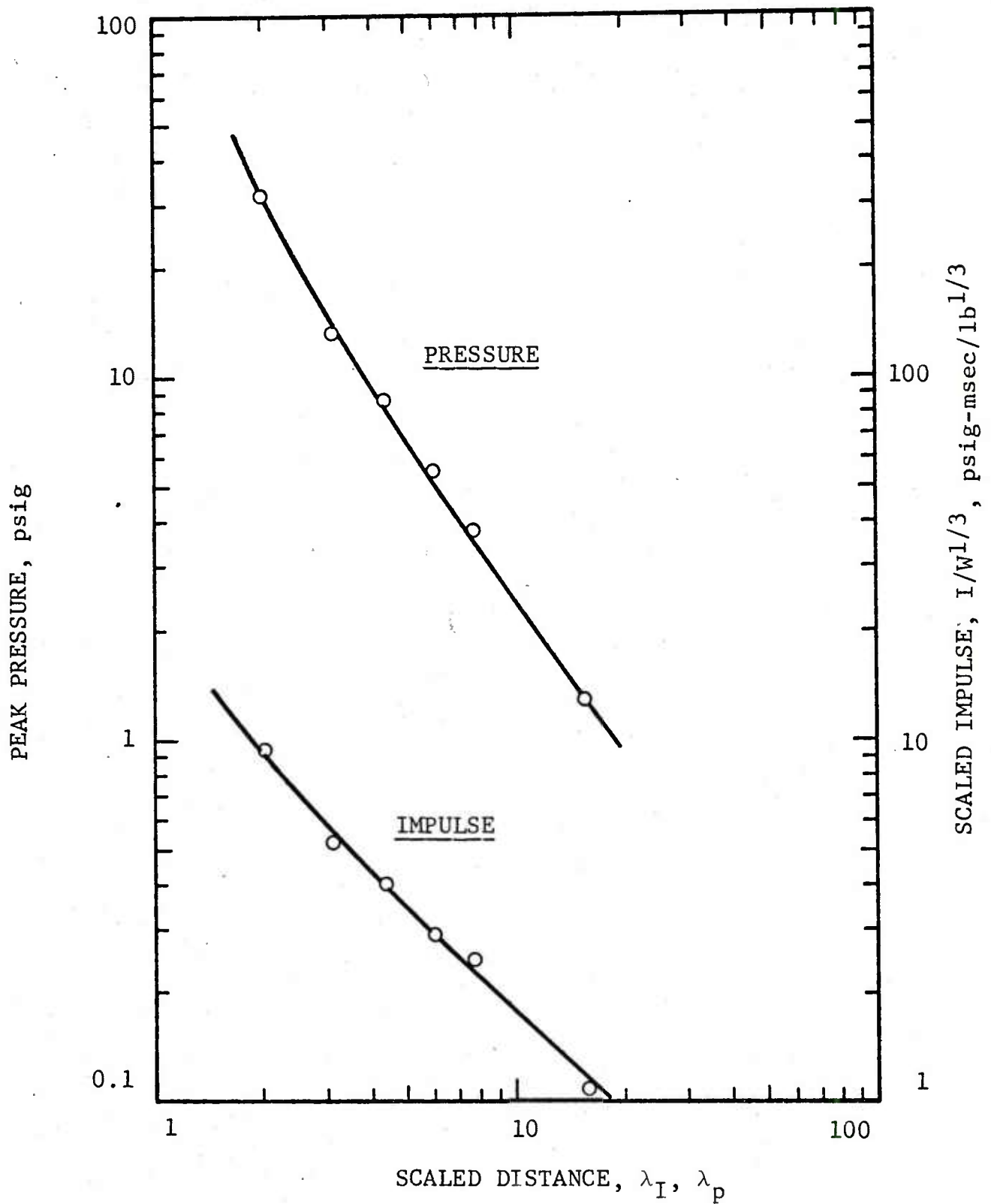

Figure A.1 PRESSURE AND IMPULSE; TEST BO-5
 25 lb BLACK POWDER, 0.25 lb C4 BOOSTER

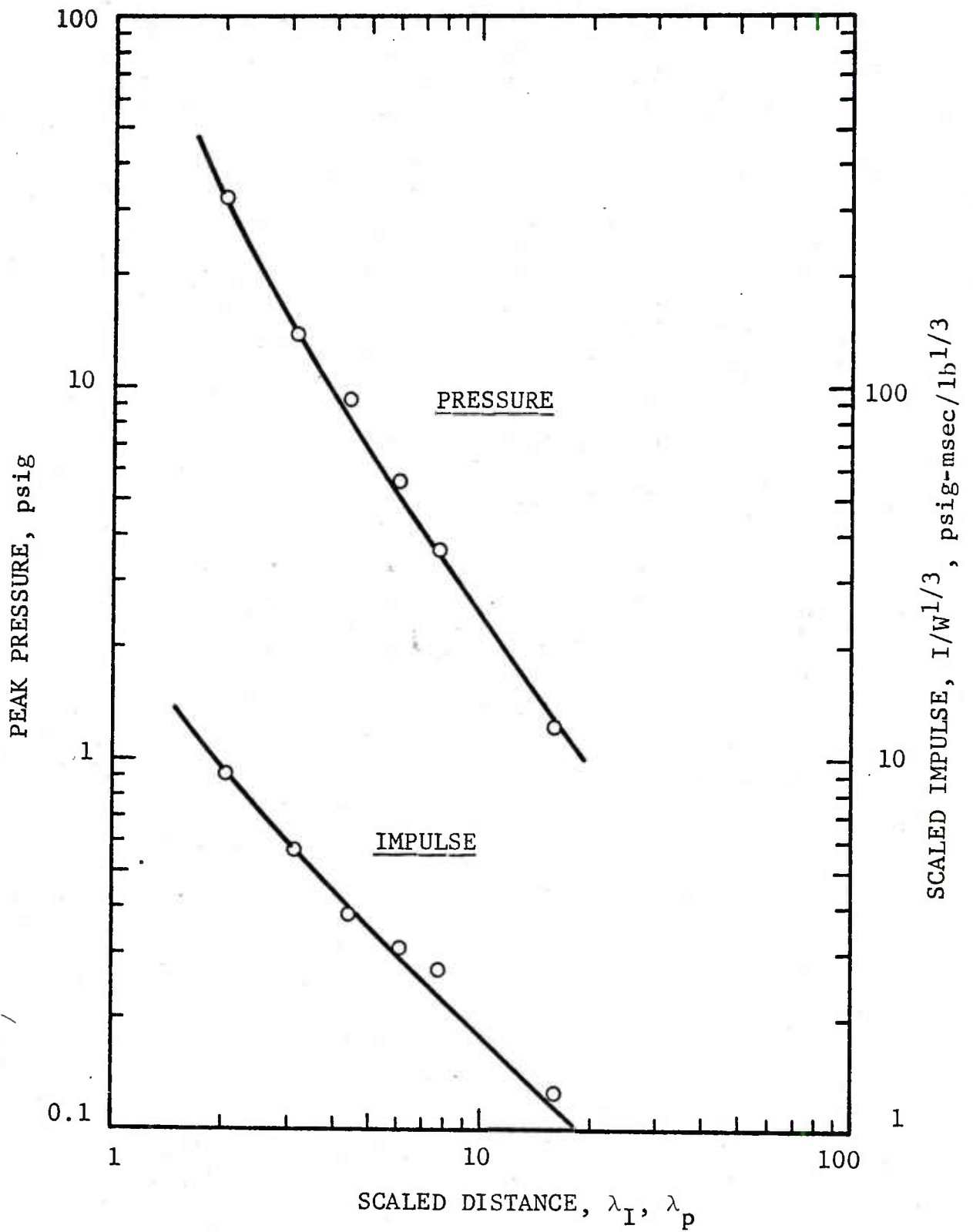

Figure A.2 PRESSURE AND IMPULSE; TEST BO-6
25 lb BLACK POWDER, 0.25 lb C4 BOOSTER

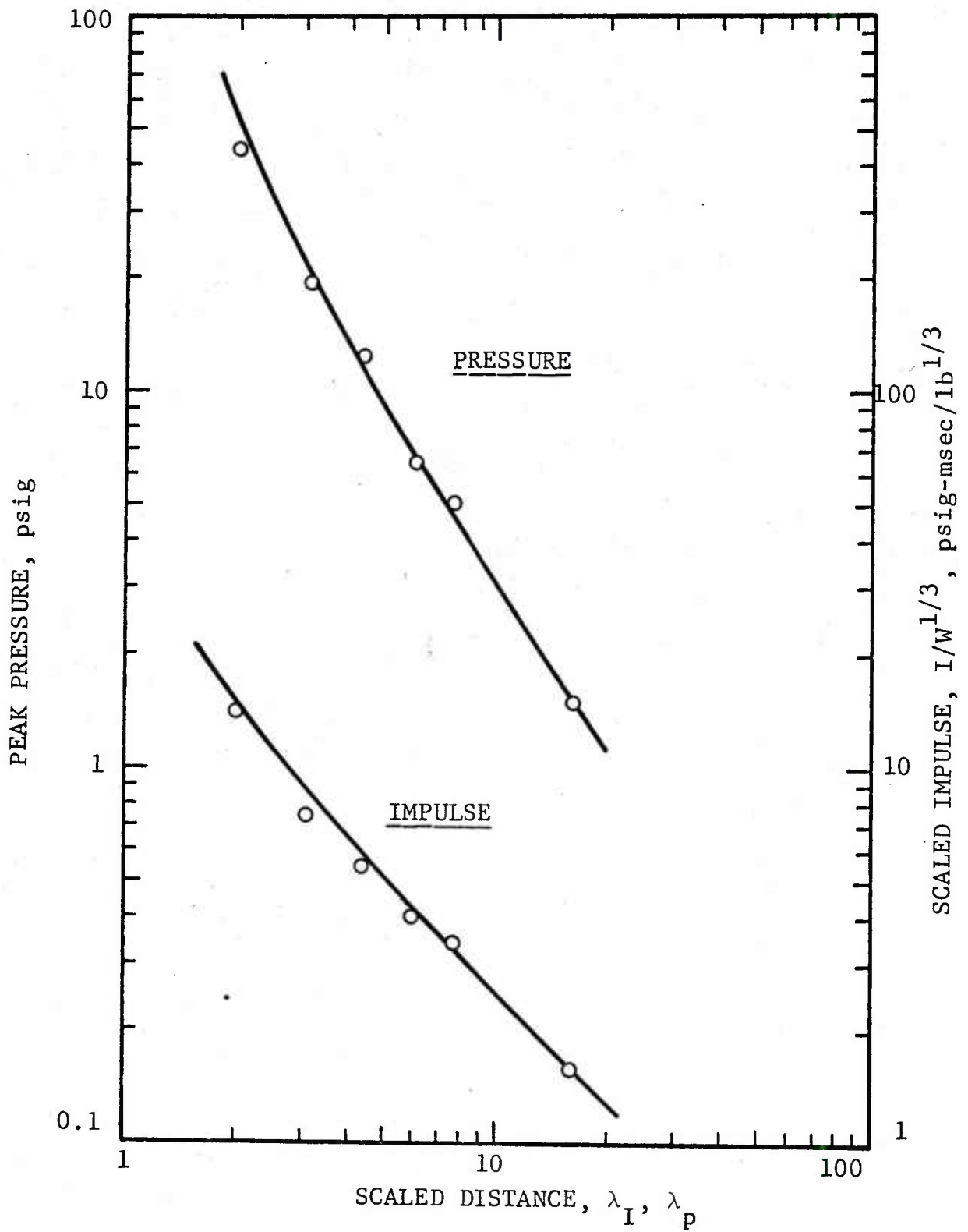

Figure A.3 PRESSURE AND IMPULSE; TEST BO-3
25 lb BLACK POWDER, 0.50 lb C4 BOOSTER

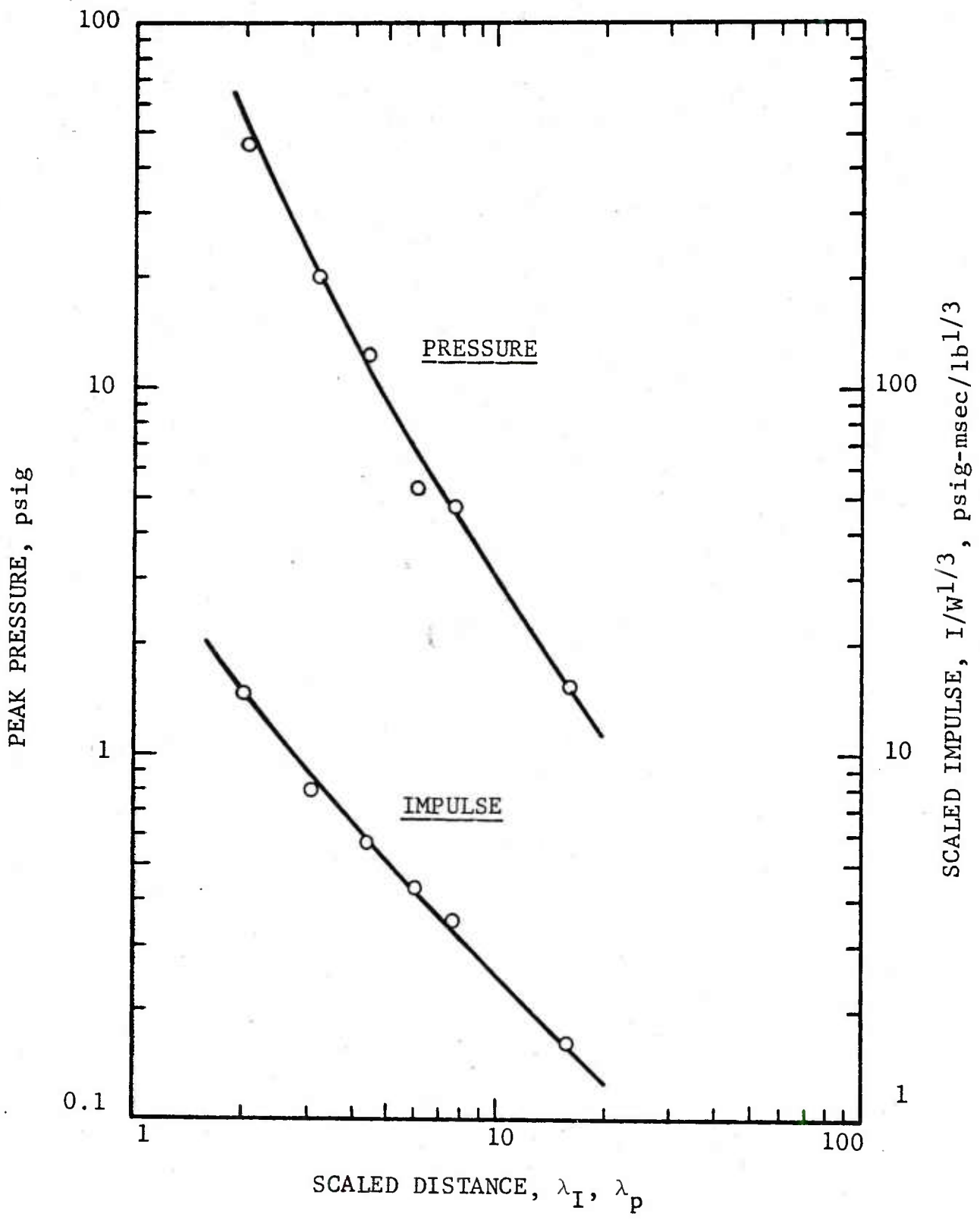

Figure A.4 PRESSURE AND IMPULSE; TEST BO-9
 25 lb BLACK POWDER, 0.50 lb C4 BOOSTER

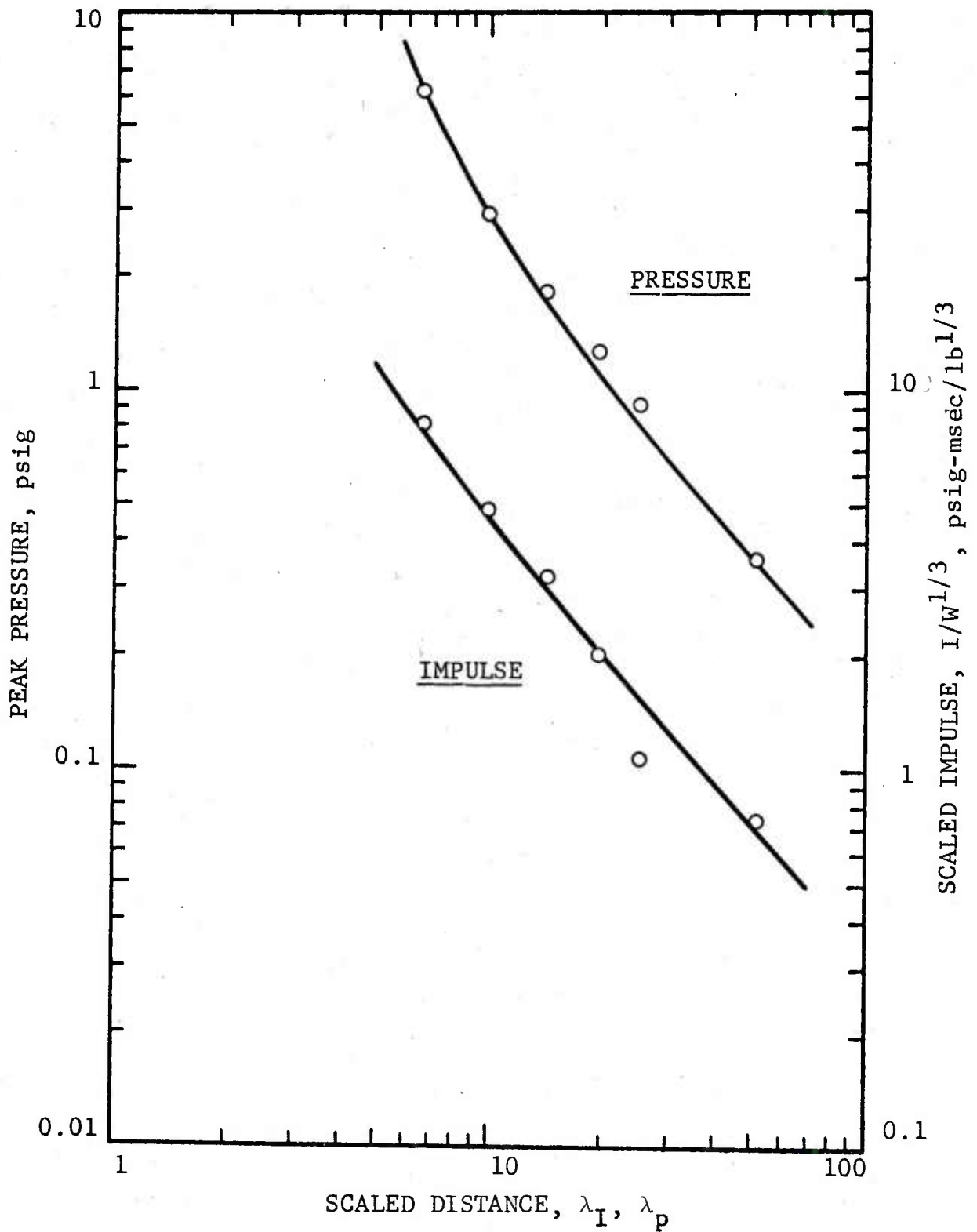

Figure A.5 PRESSURE AND IMPULSE; TEST BO-10
INERT CHARGE, 0.50 lb C4 BOOSTER

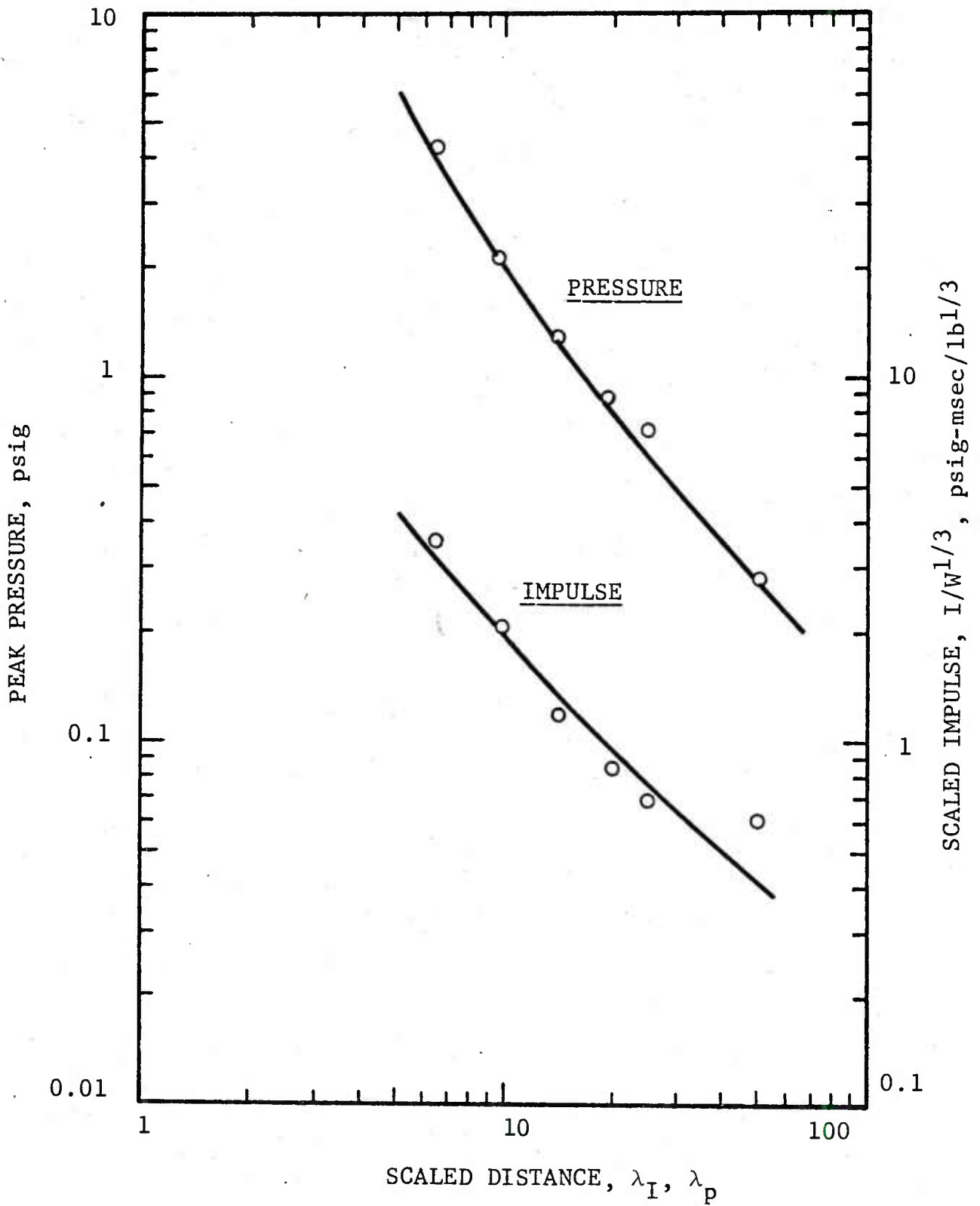

Figure A.6 PRESSURE AND IMPULSE; TEST BO-11
INERT CHARGE, 0.50 lb C4 BOOSTER

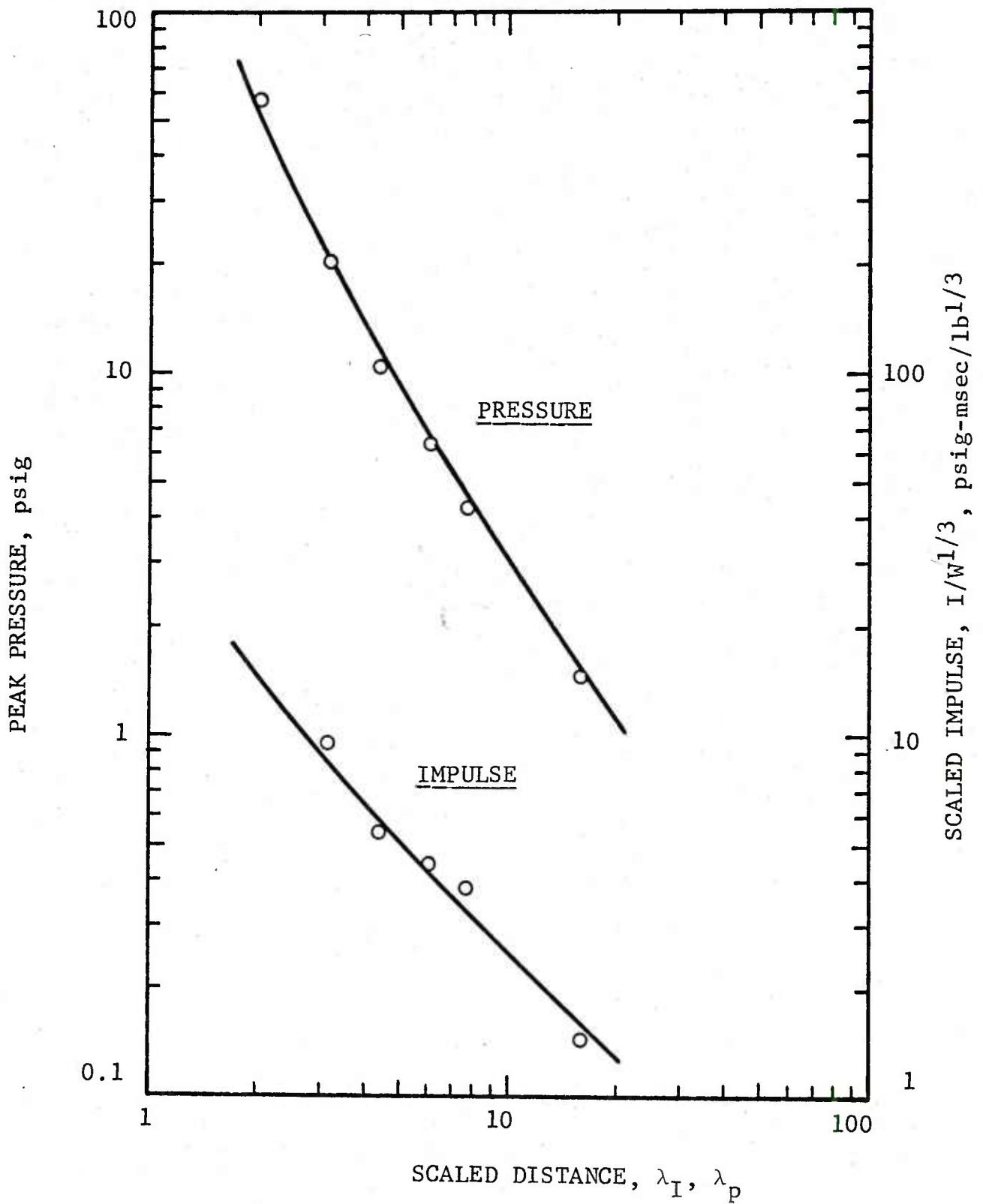

Figure A.7 PRESSURE AND IMPULSE; TEST BO-12
24 lb BLACK POWDER, 0.50 lb C4 BOOSTER

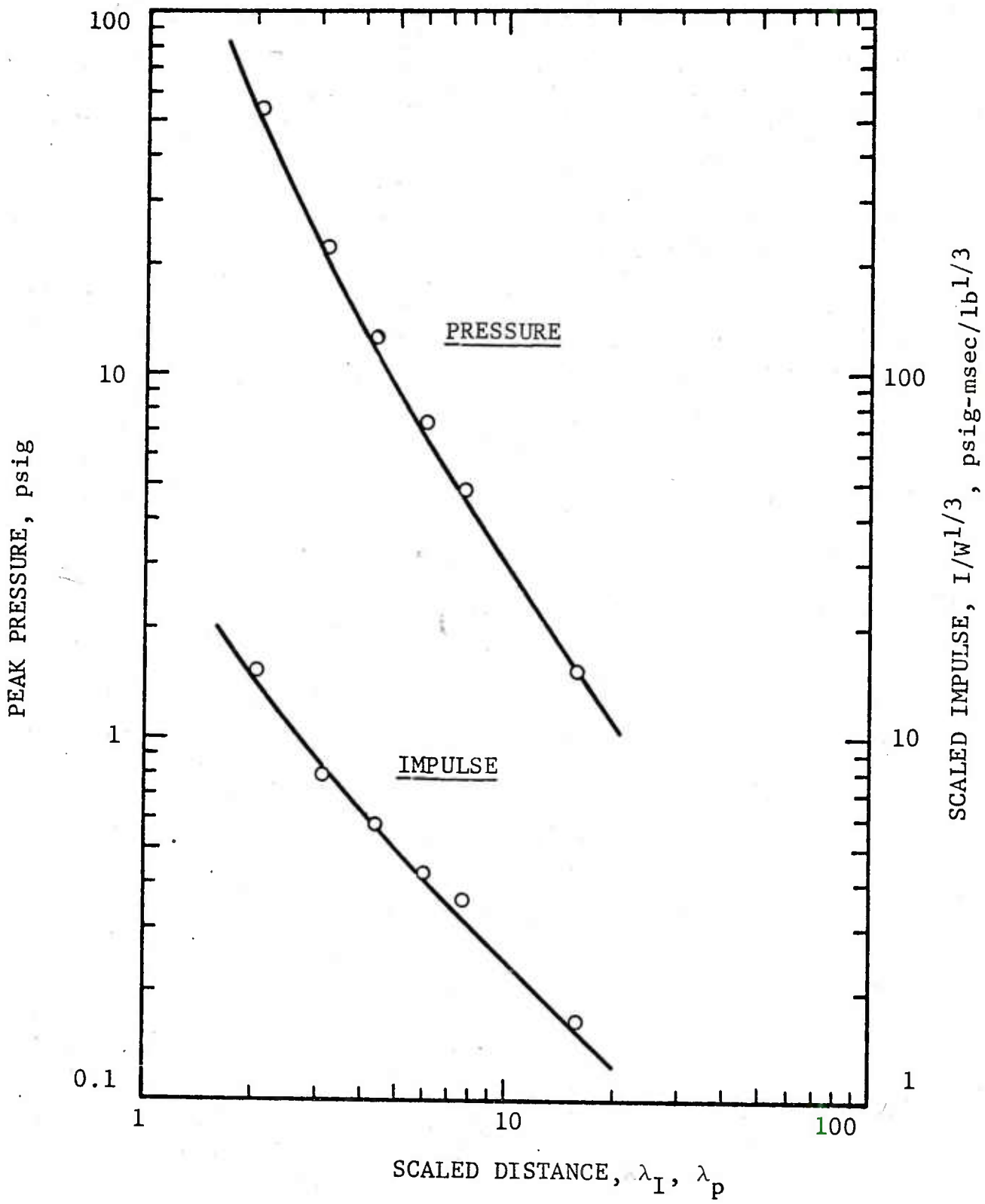

Figure A.8 PRESSURE AND IMPULSE; TEST BO-13
 25 lb BLACK POWDER, 0.50 lb C4 BOOSTER

FO 13 050 C4

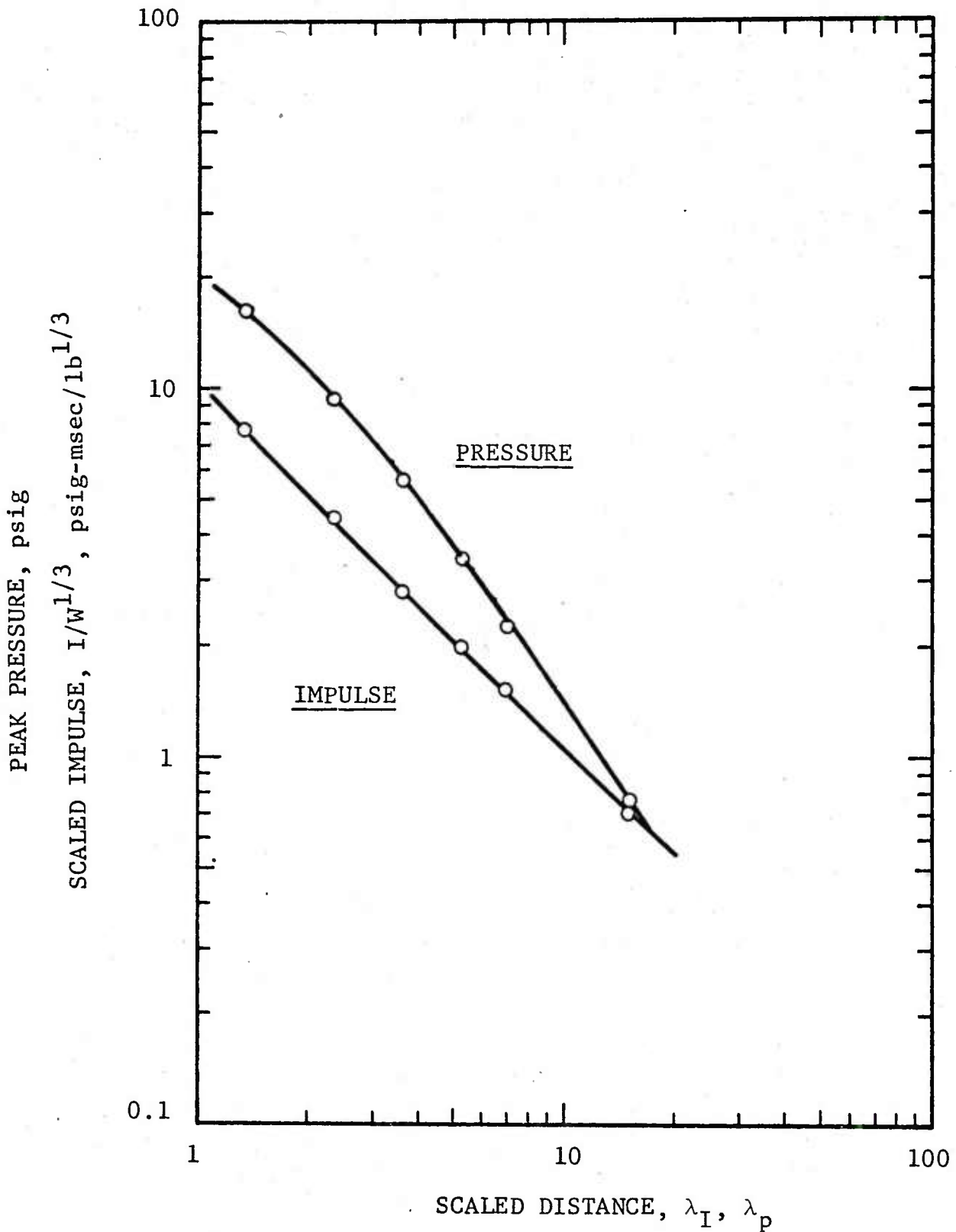

Figure A.9 PRESSURE AND IMPULSE; TEST BO-14
 27 lb BLACK POWDER, 0.024 TETRYL BOOSTER

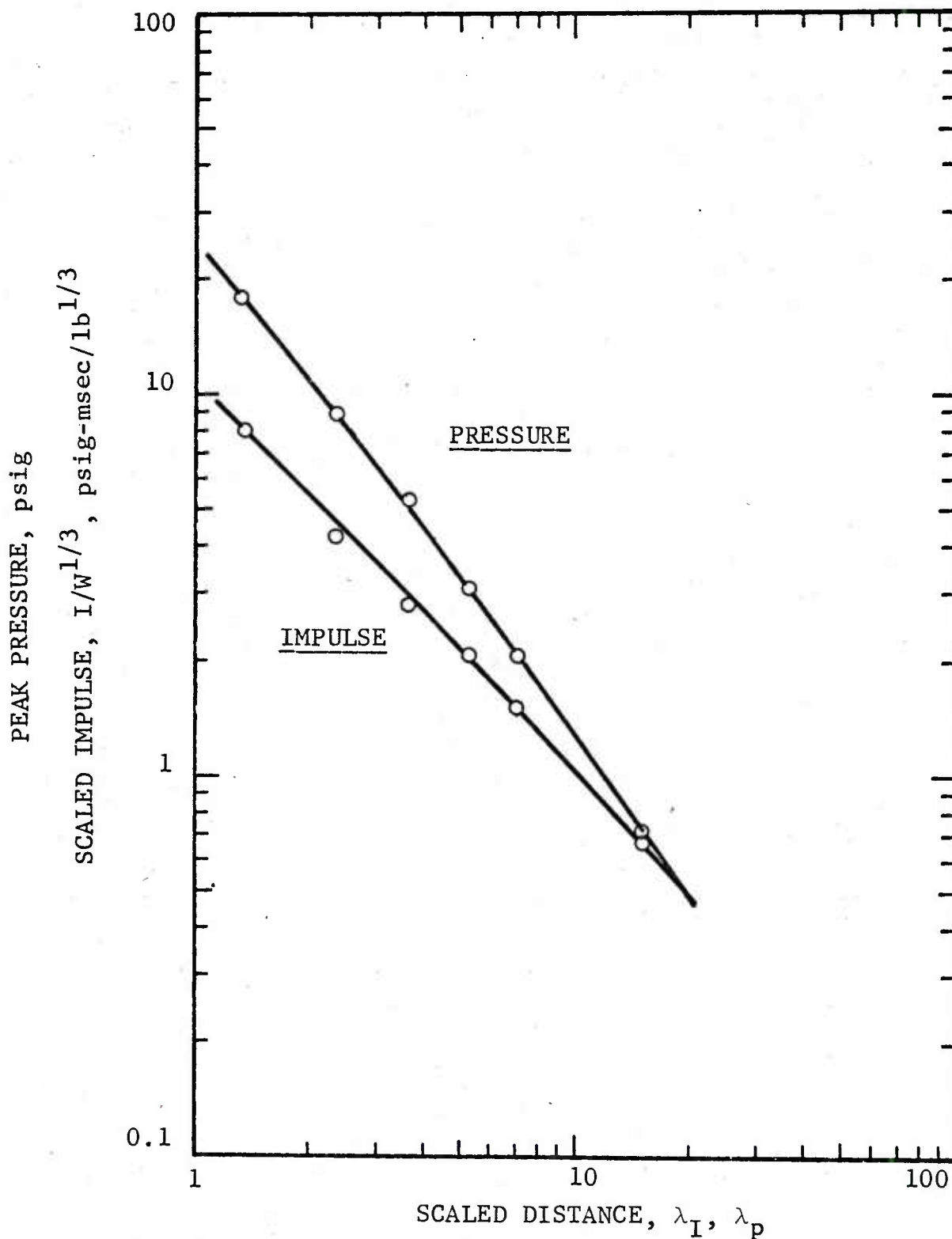

Figure A.10

PRESSURE AND IMPULSE; TEST BO-15
 27 lb BLACK POWDER, 0.024 lb TETRYL BOOSTER

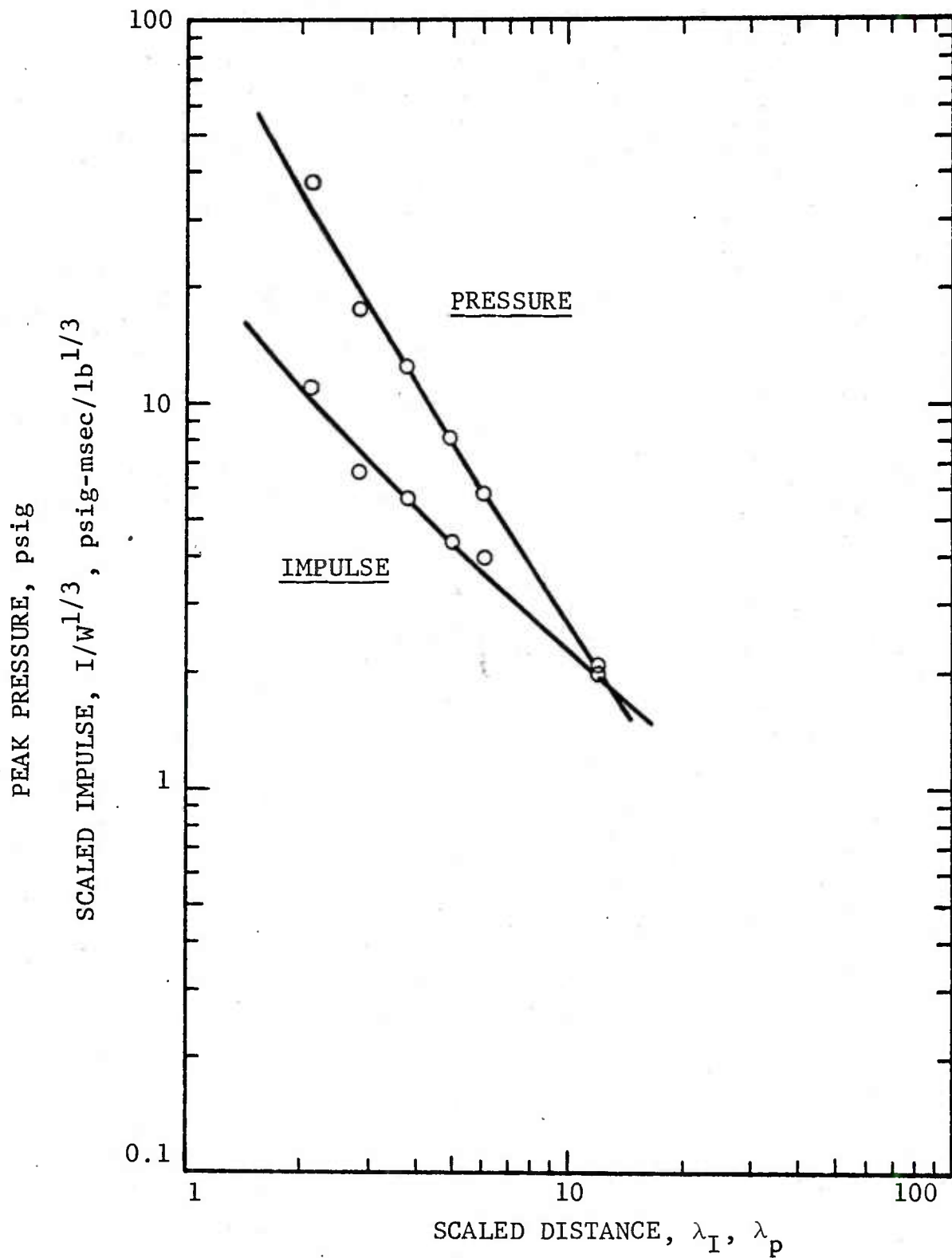

Figure A.11 PRESSURE AND IMPULSE; TEST BO-16
 75 lb BLACK POWDER, 0.50 lb C4 BOOSTER

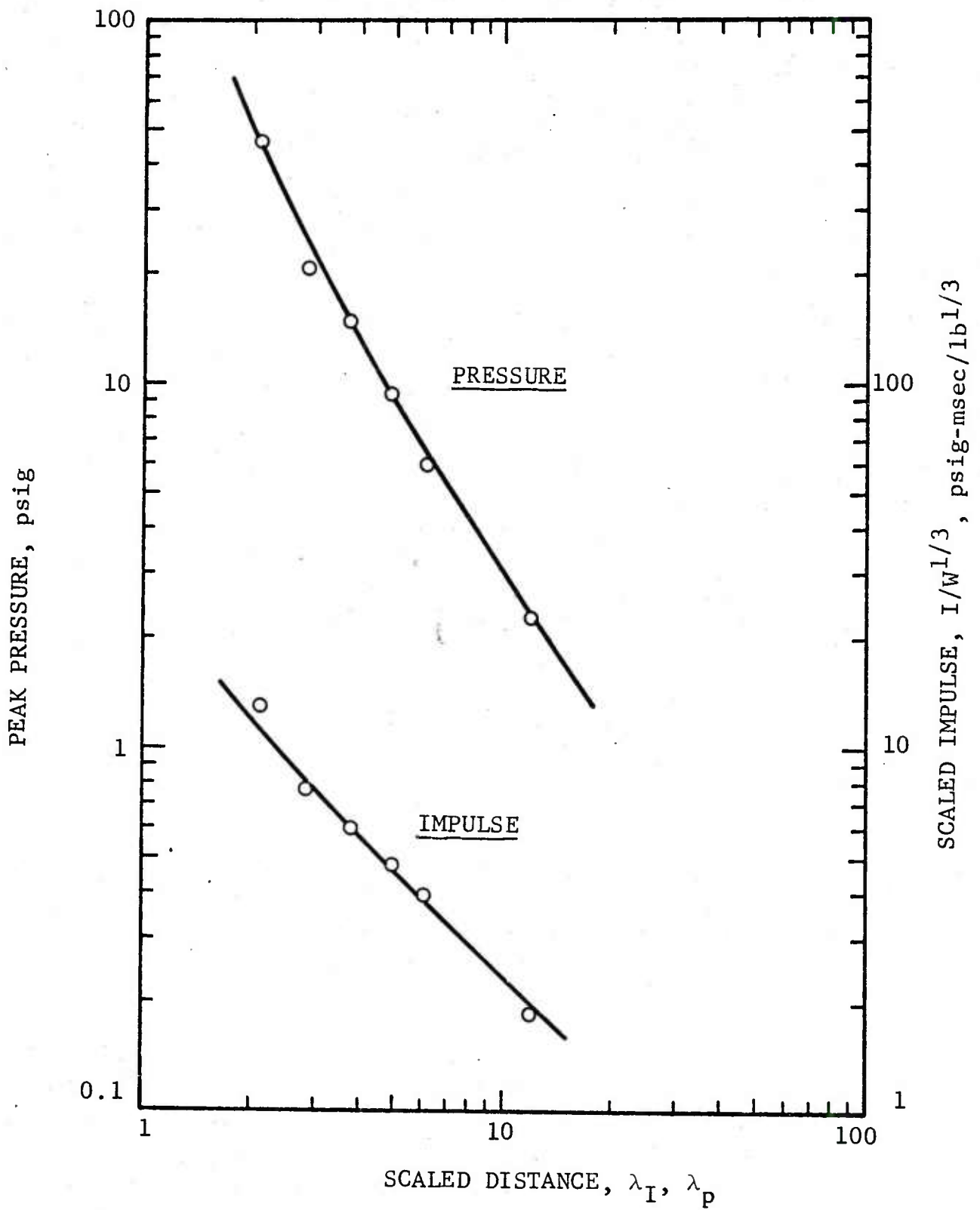

Figure A.12 PRESSURE AND IMPULSE; TEST BO-17
75 lb BLACK POWDER, 0.50 lb C4 BOOSTER

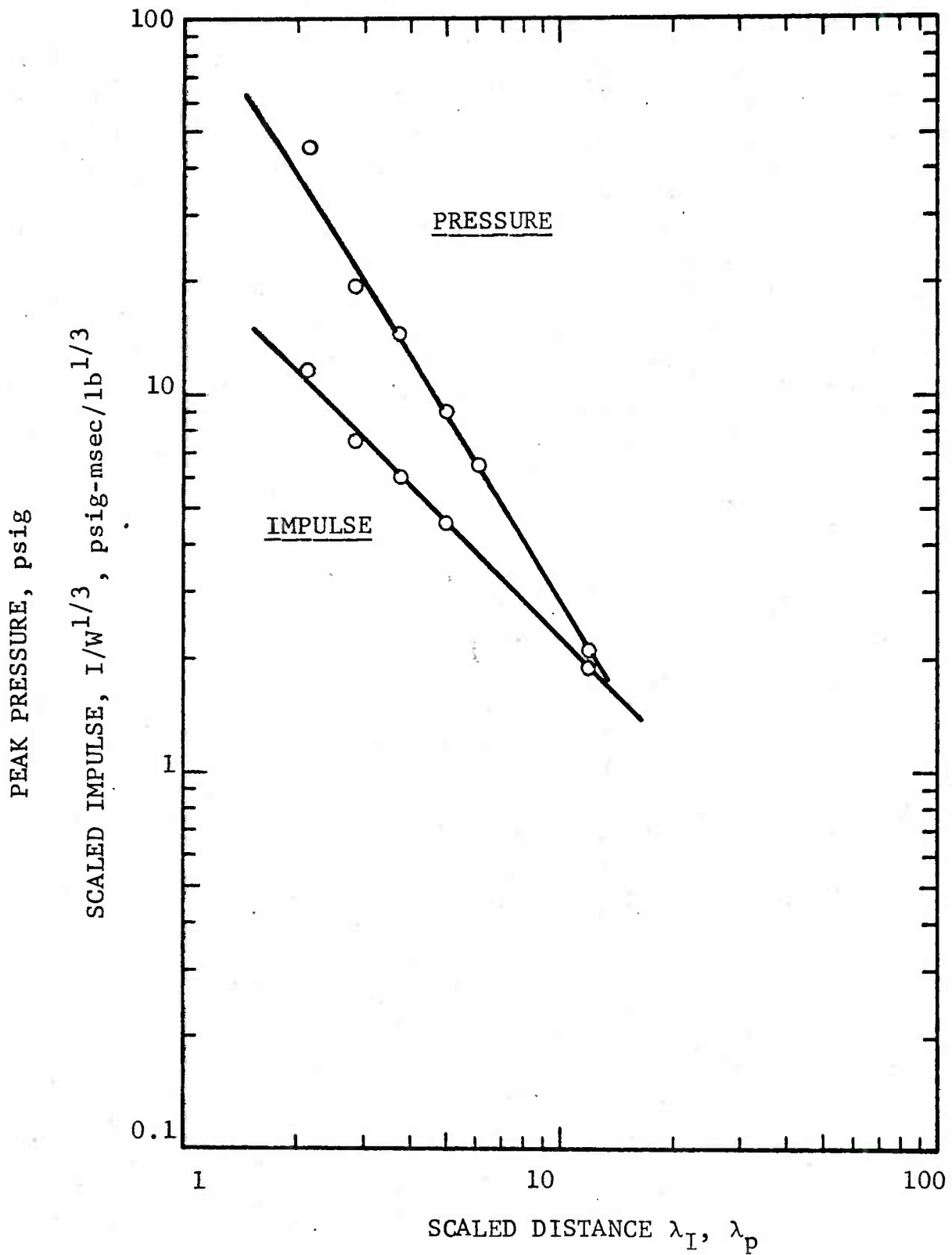

Figure A.13 PRESSURE AND IMPULSE; TEST BO-18
 75 lb BLACK POWDER, 0.50 lb C4 BOOSTER
 A-26

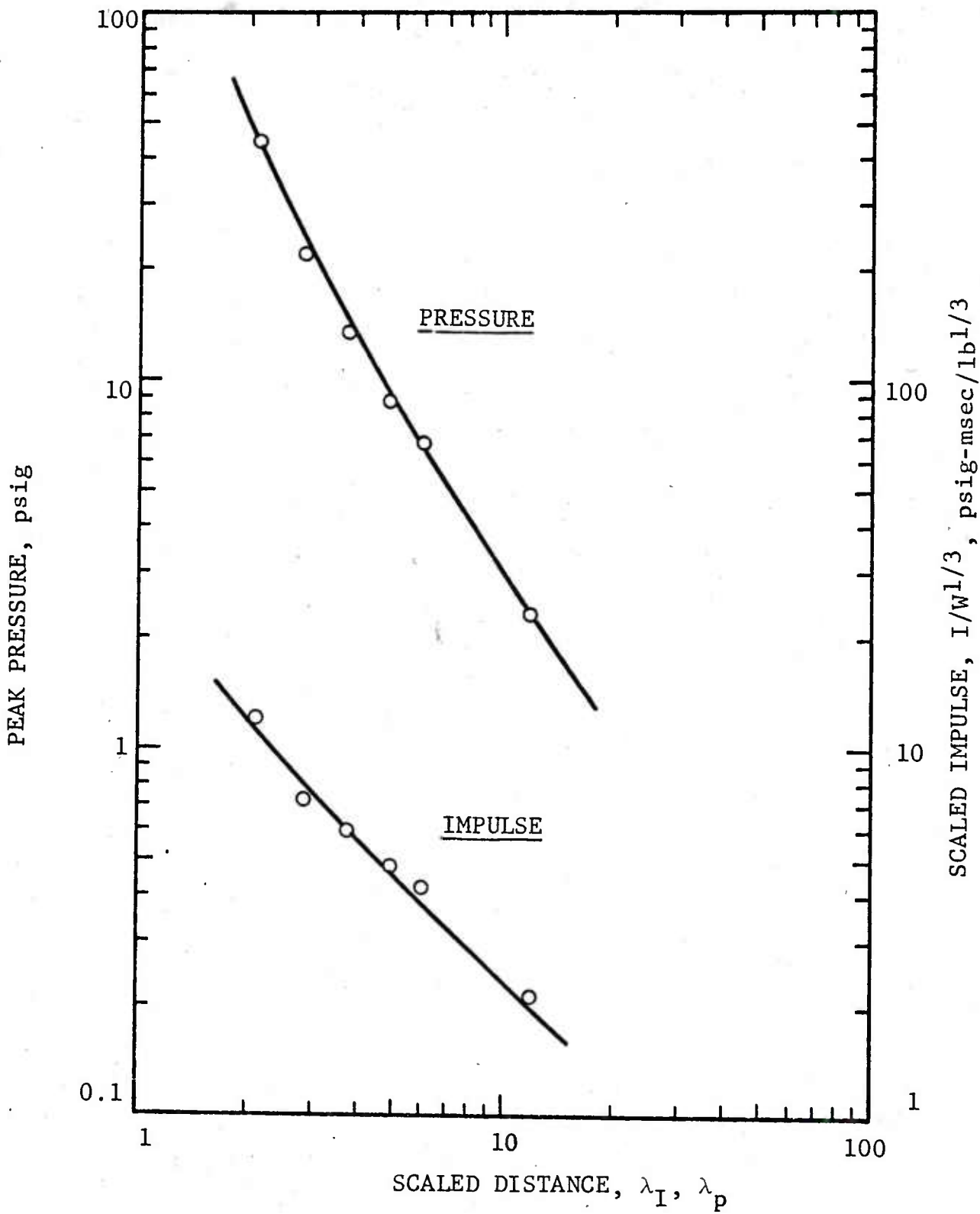

Figure A.14 PRESSURE AND IMPULSE; TEST BO-19
75 lb BLACK POWDER, 0.50 lb C4 BOOSTER

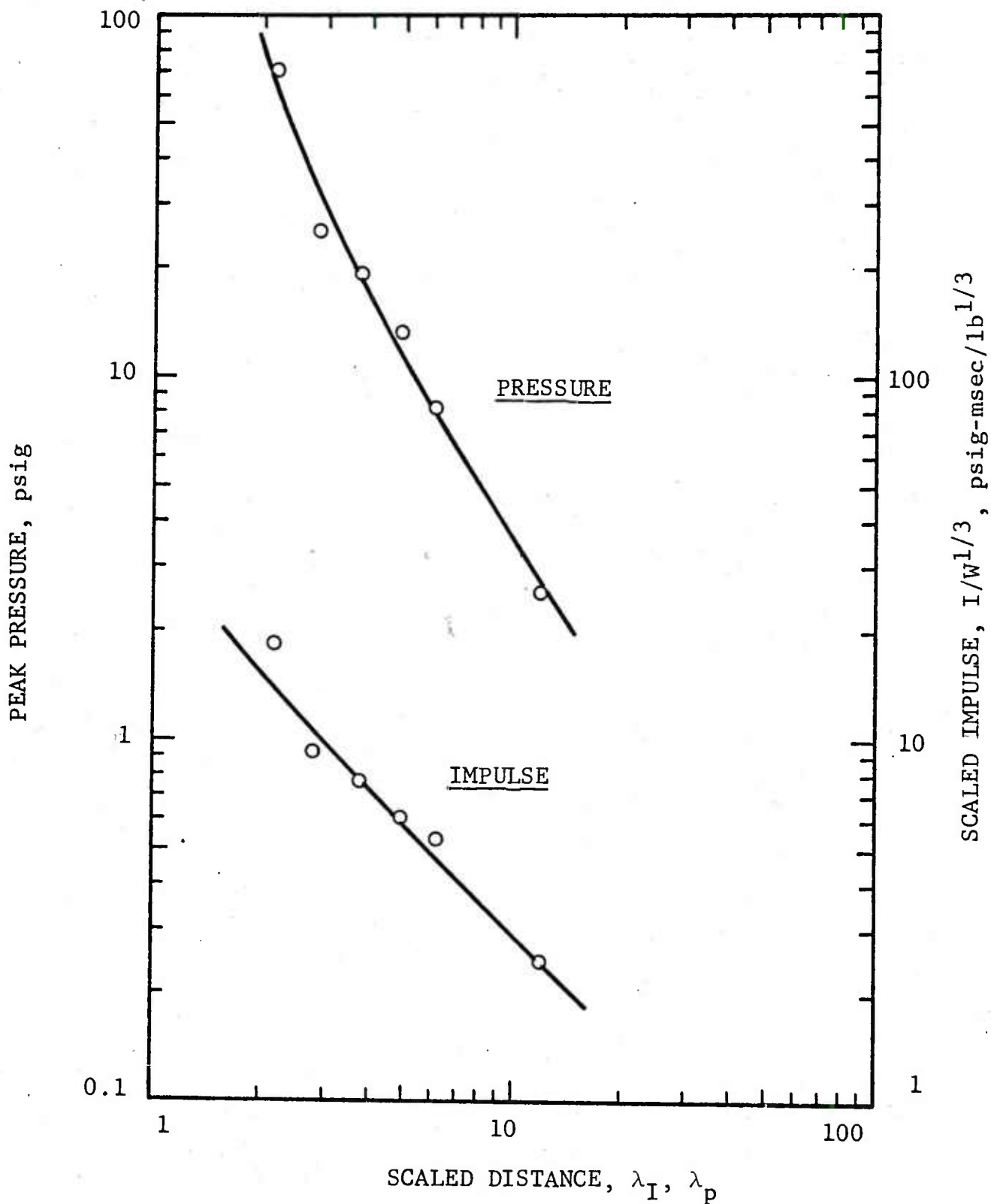

Figure A.15 PRESSURE AND IMPULSE; TEST BO-20
75 lb BLACK POWDER, 1.00 lb C4 BOOSTER

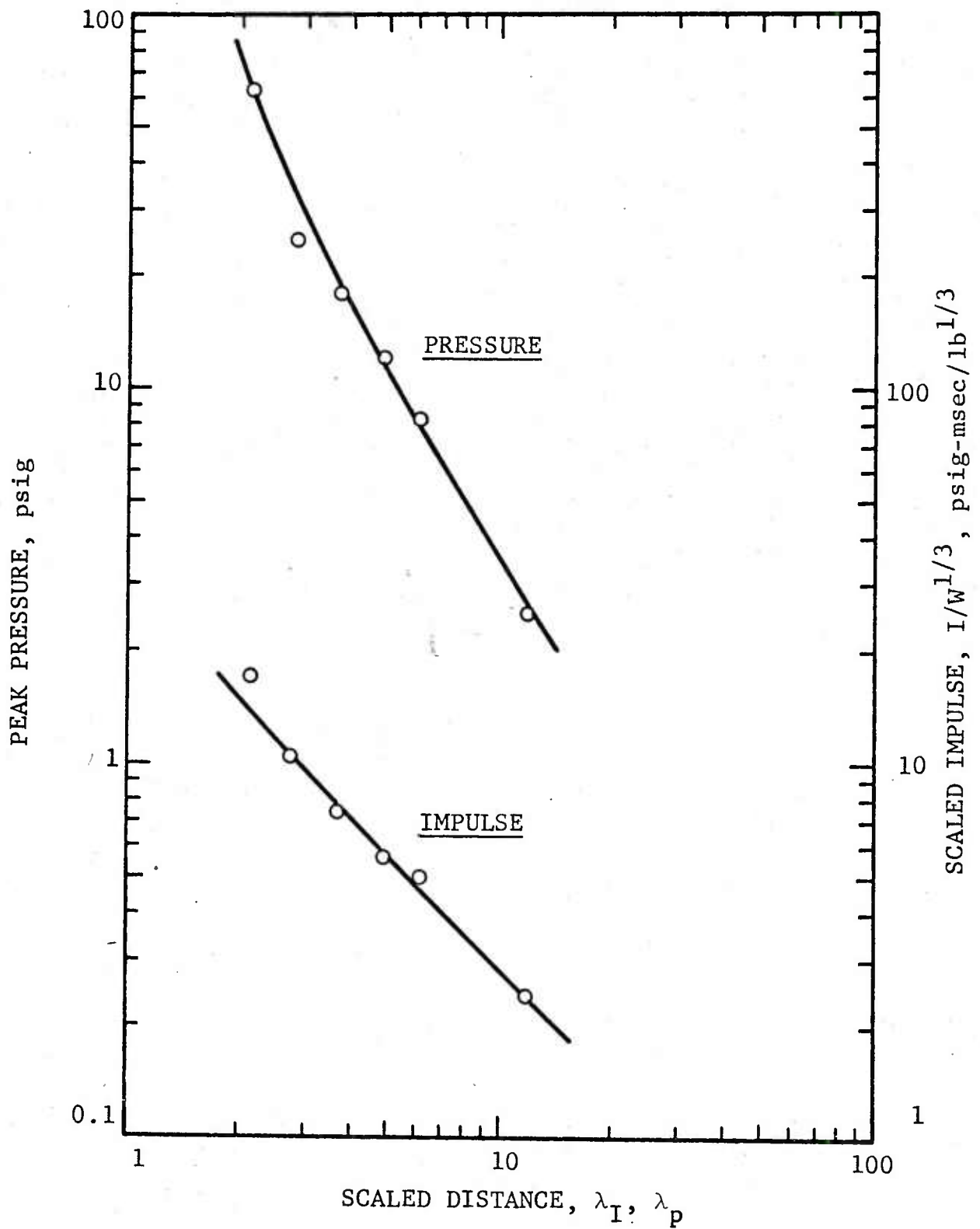

Figure A.16 PRESSURE AND IMPULSE; TEST BO-21
74 lb BLACK POWDER, 1.00 lb C4 BOOSTER

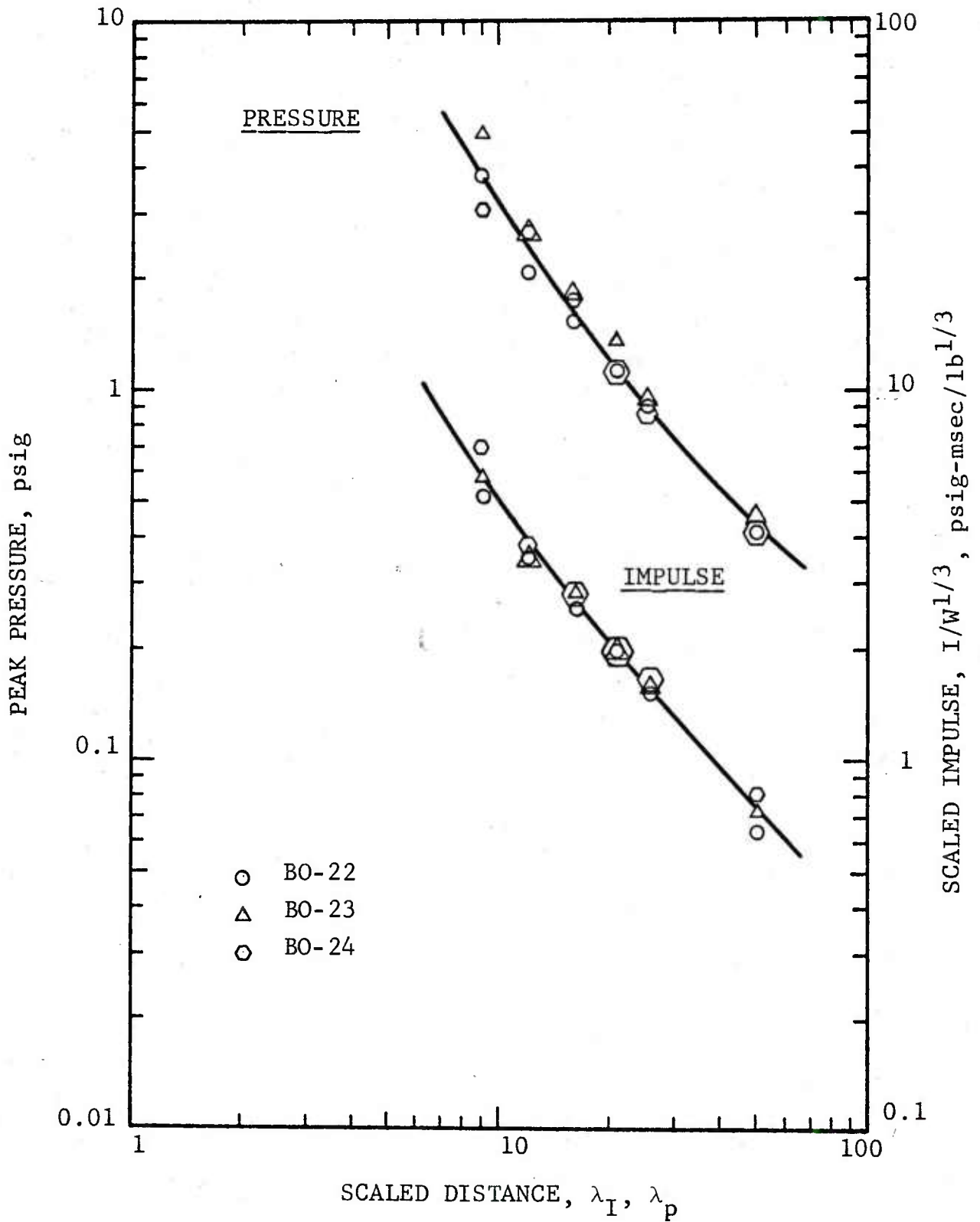

Figure A.17 PRESSURE AND IMPULSE; TESTS BO-22,23,24
INERT CHARGE

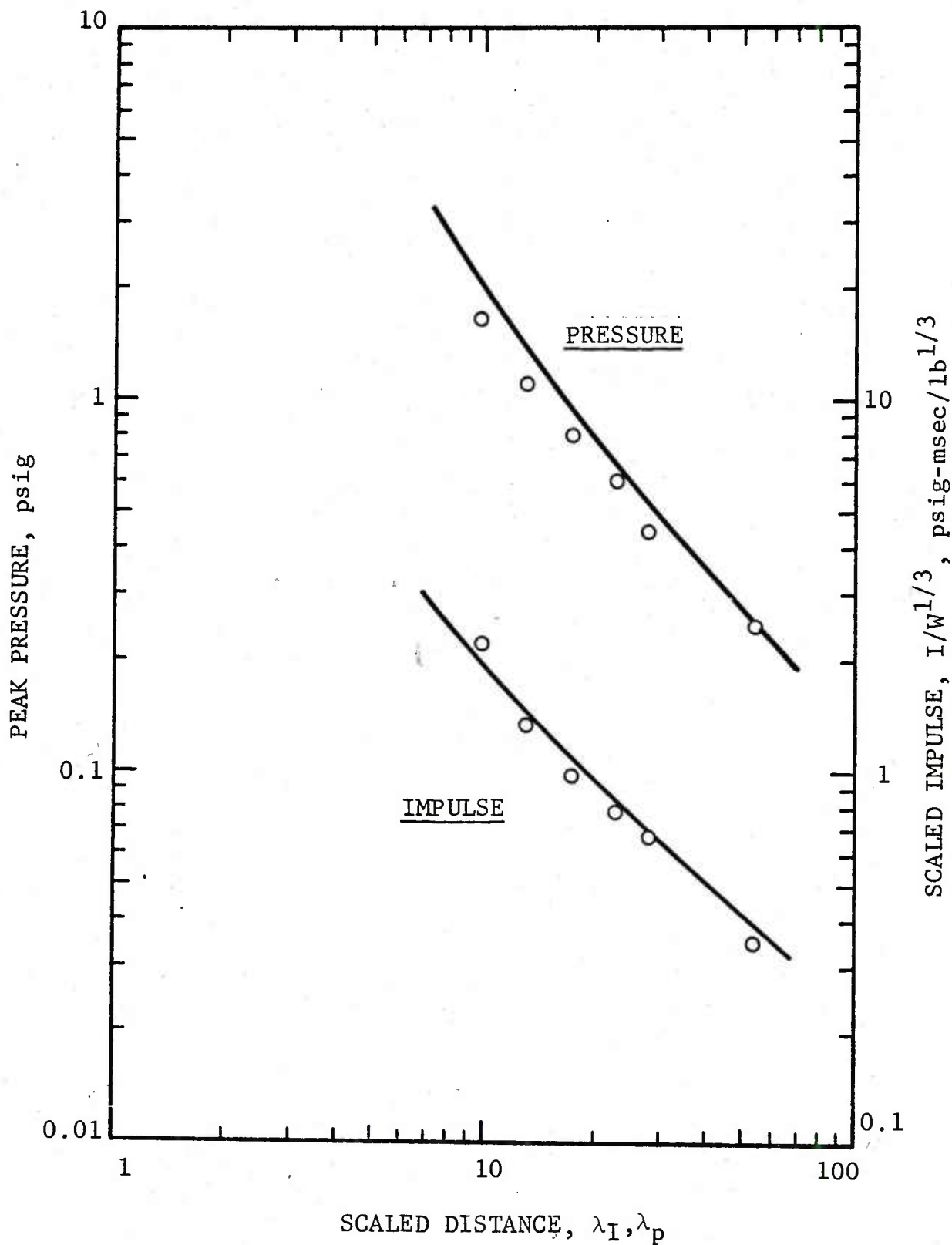

Figure A.18 PRESSURE AND IMPULSE; TEST BO-25
INERT CHARGE, 1.00 lb C4 BOOSTER

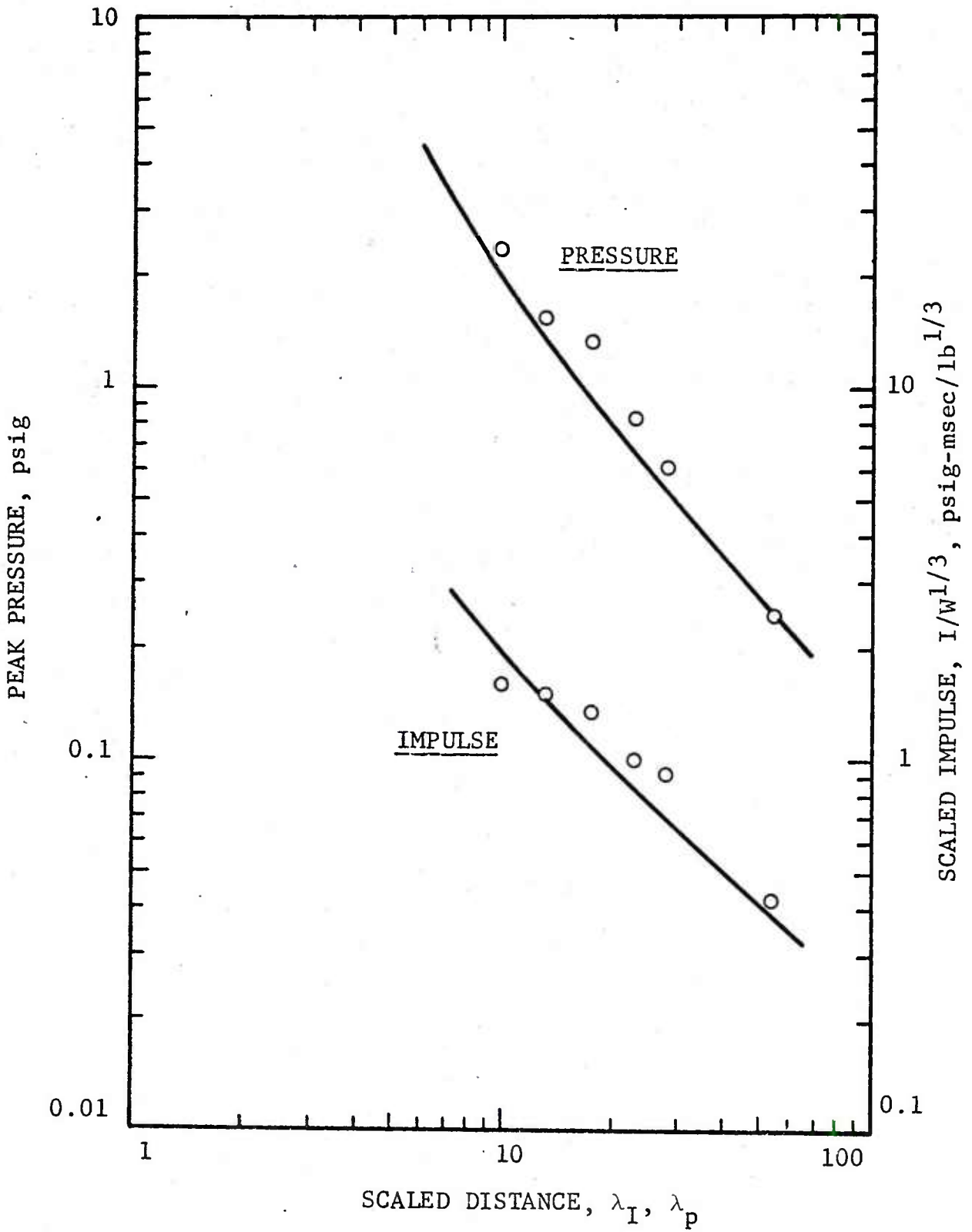

Figure A.19 PRESSURE AND IMPULSE; TEST BO-26
INERT CHARGE, 0.50 lb C4 BOOSTER

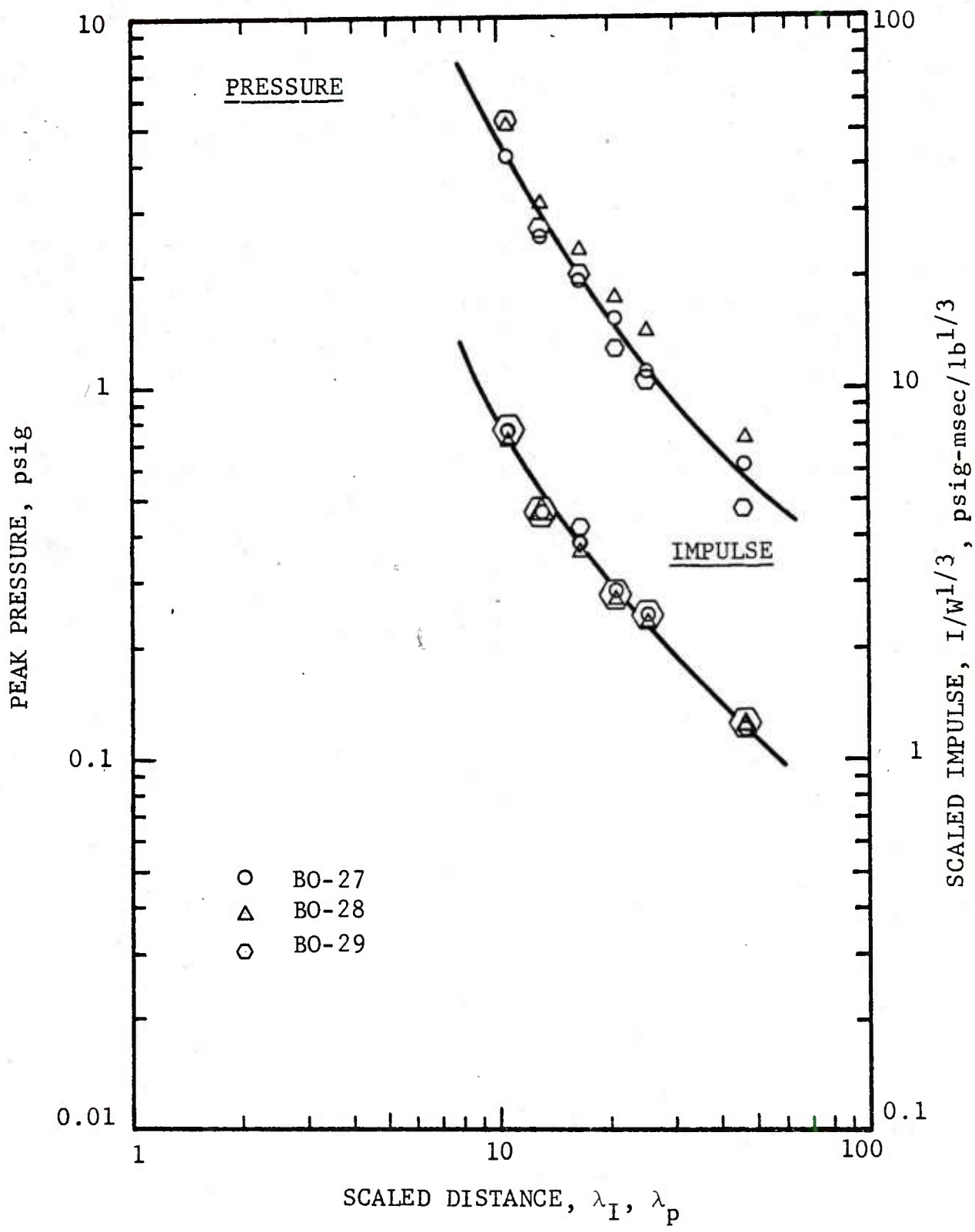

Figure A.20 PRESSURE AND IMPULSE; TESTS BO-27,28,29
INERT CHARGE

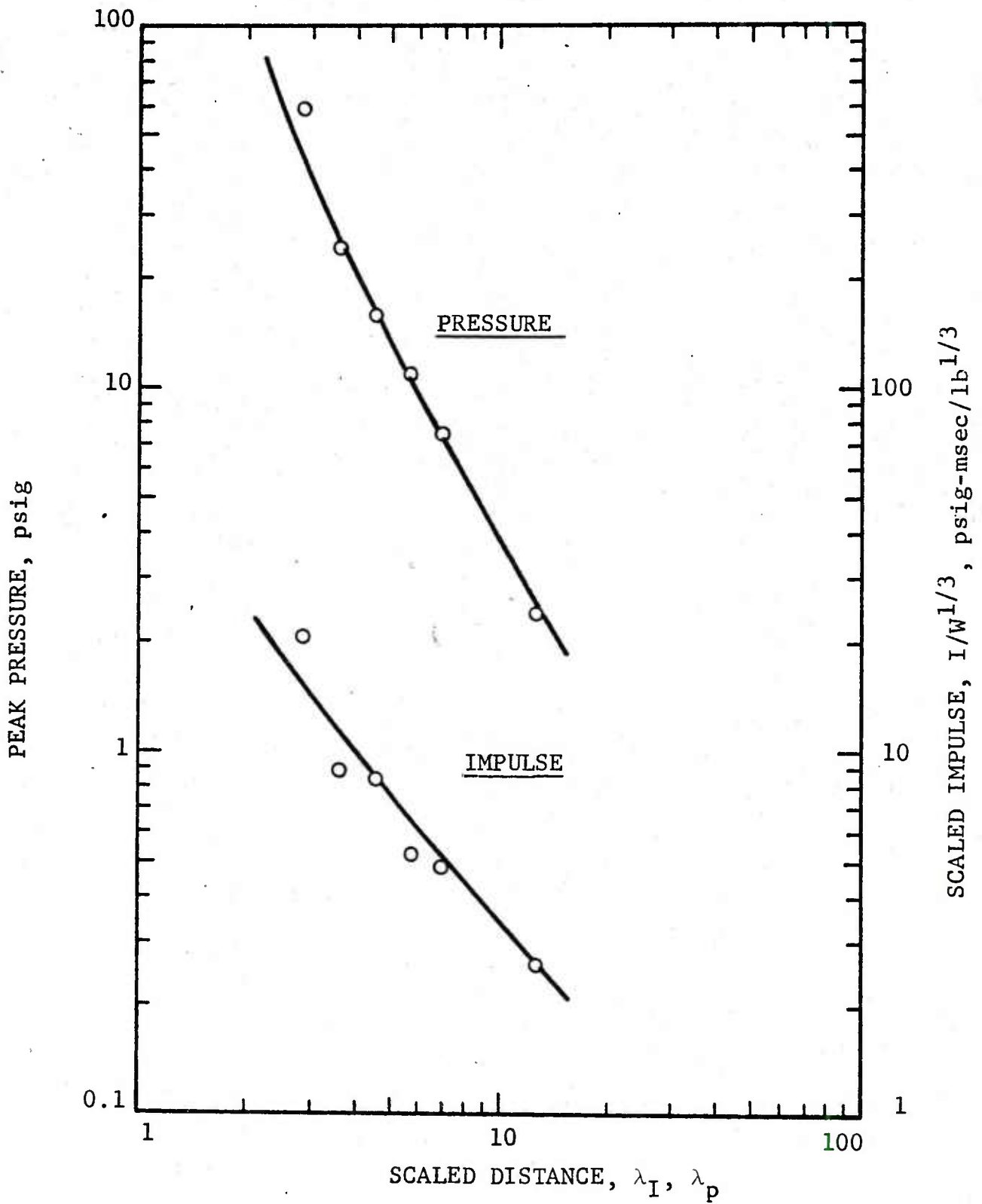

Figure A.21

PRESSURE AND IMPULSE; TEST BO-30
 75 lb BLACK POWDER, 1.50 lb C4 BOOSTER

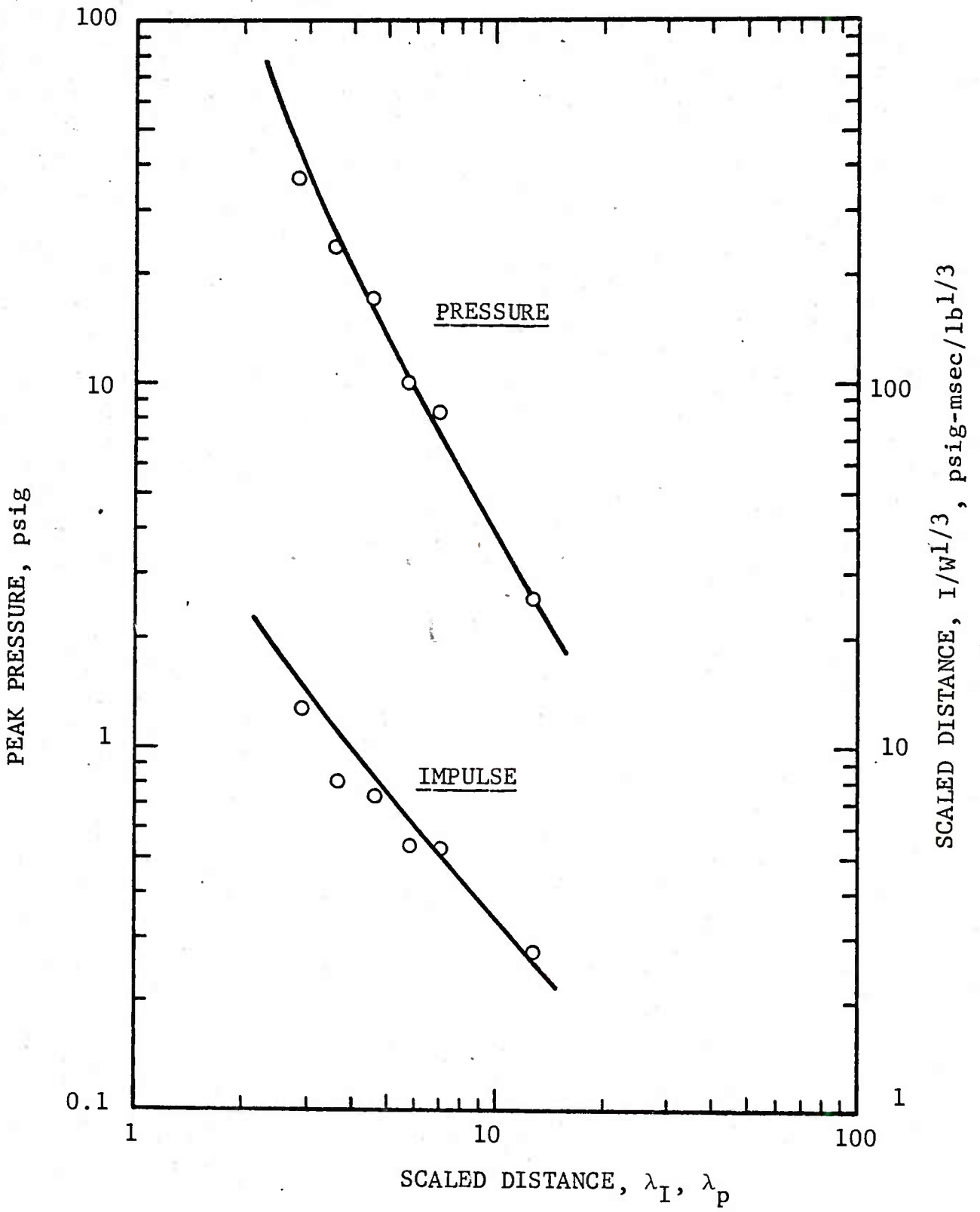

Figure A.22

PRESSURE AND IMPULSE; TEST B0-31
 75 lb BLACK POWDER, 1.50 lb C4 BOOSTER

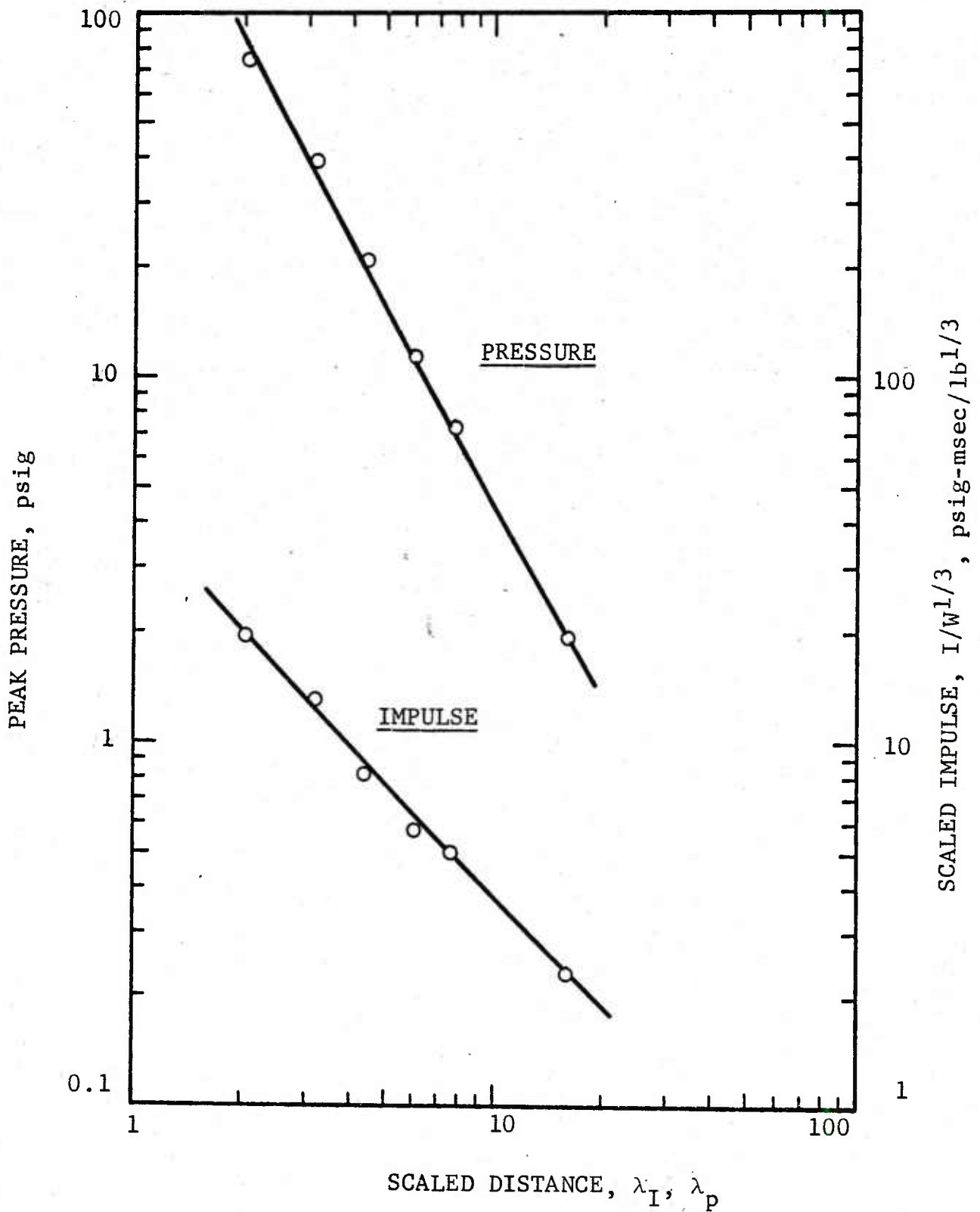

Figure A.23

PRESSURE AND IMPULSE; TEST BO-32
 25 lb BLACK POWDER, 1.00 lb C4 BOOSTER

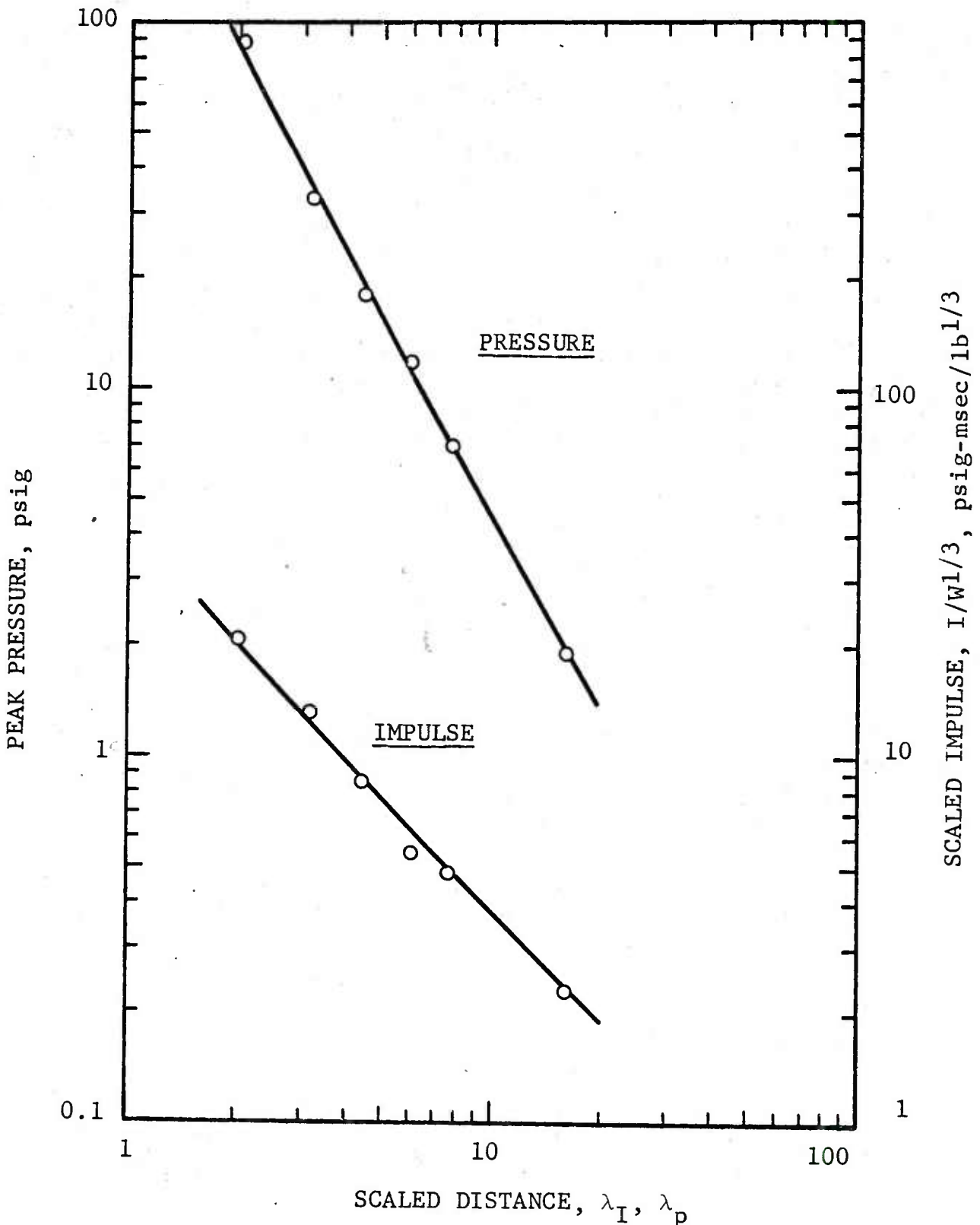

Figure A.24 PRESSURE AND IMPULSE; TEST BO-33
 25 lb BLACK POWDER, 1.00 lb C4 BOOSTER

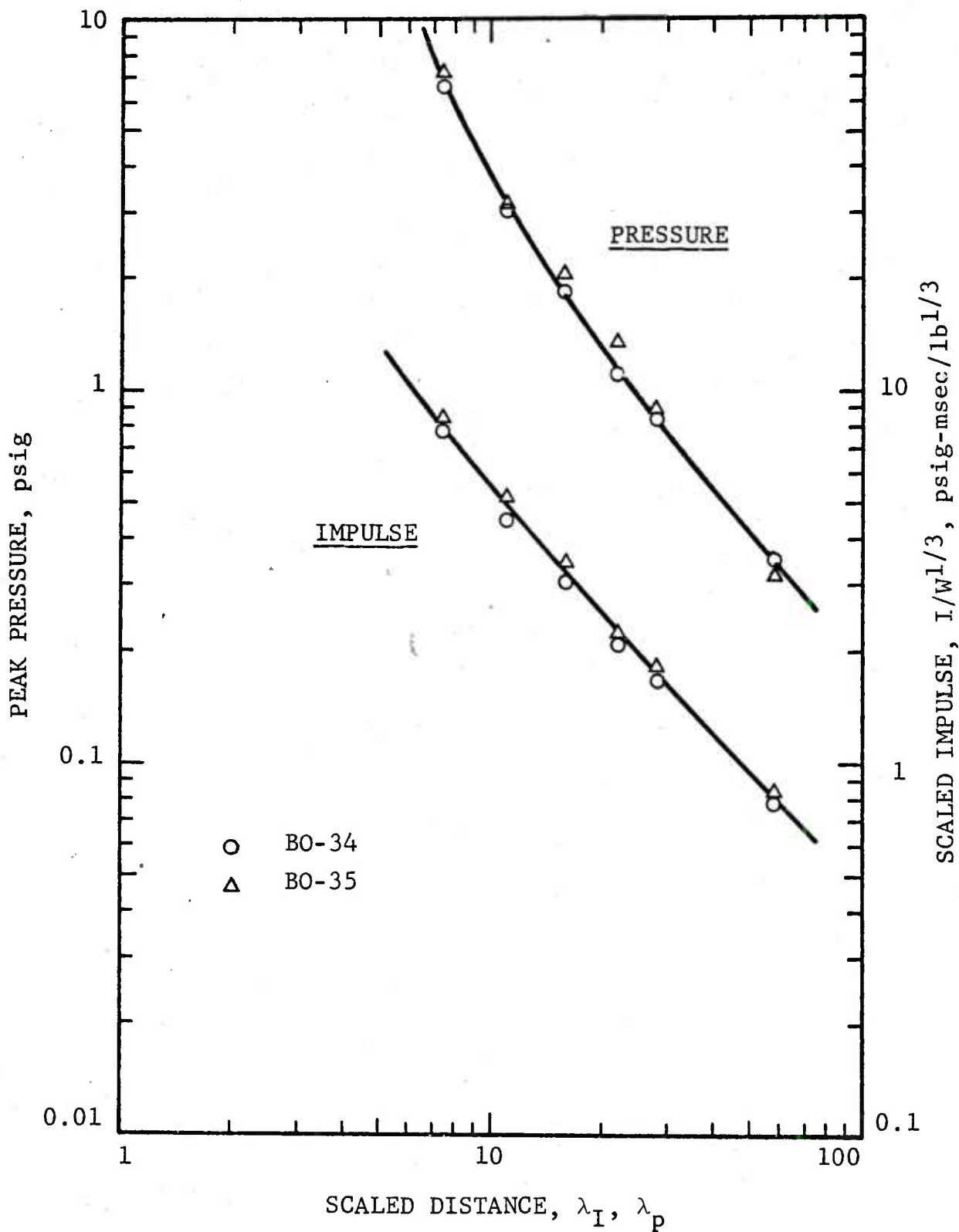

Figure A.25 PRESSURE AND IMPULSE; TESTS BO-34,35
INERT CHARGE, 0.54 lb PBX BOOSTER

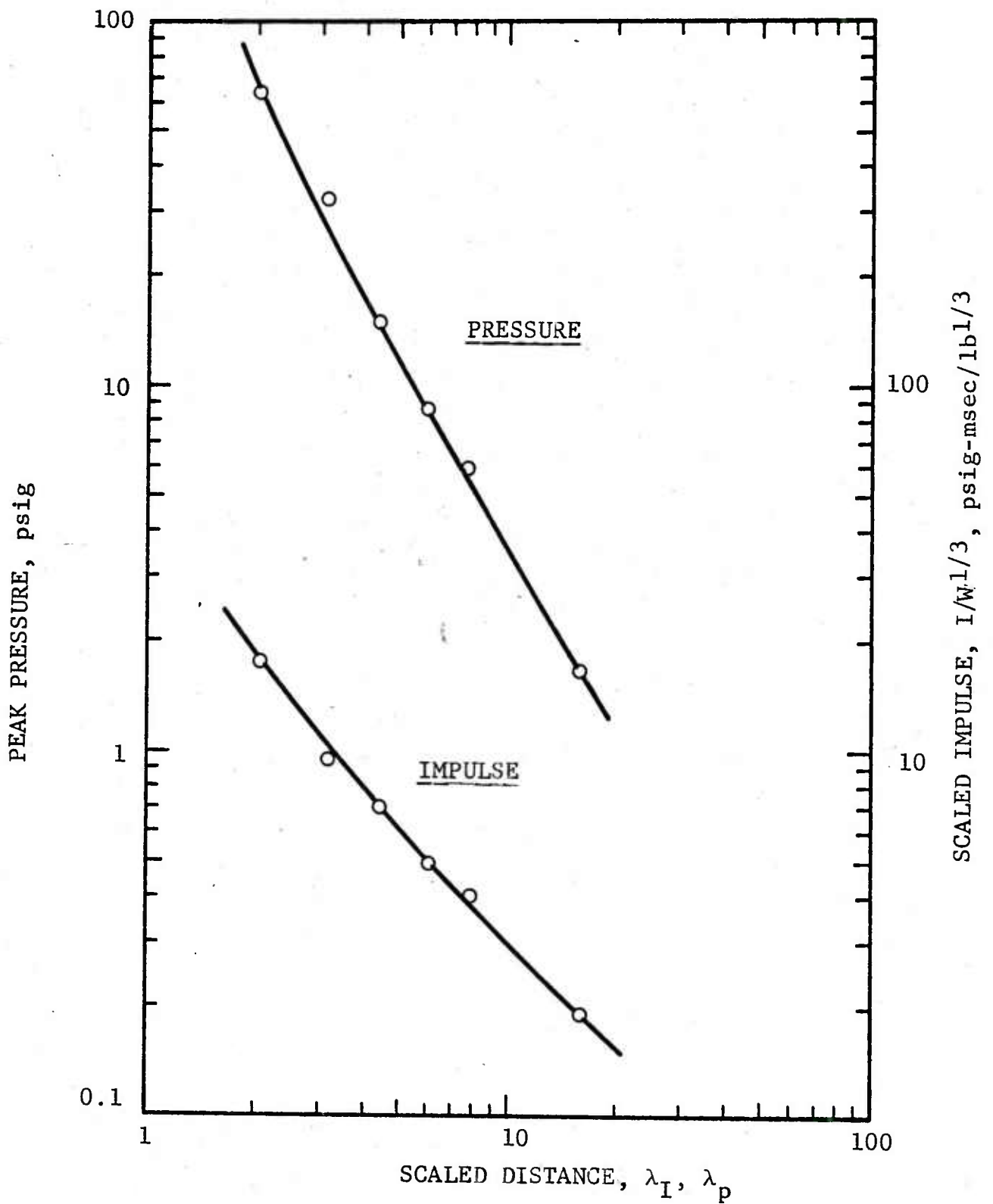

Figure A.26 PRESSURE AND IMPULSE; TEST BO-36
25 lb BLACK POWDER, 0.54 lb PBX BOOSTER

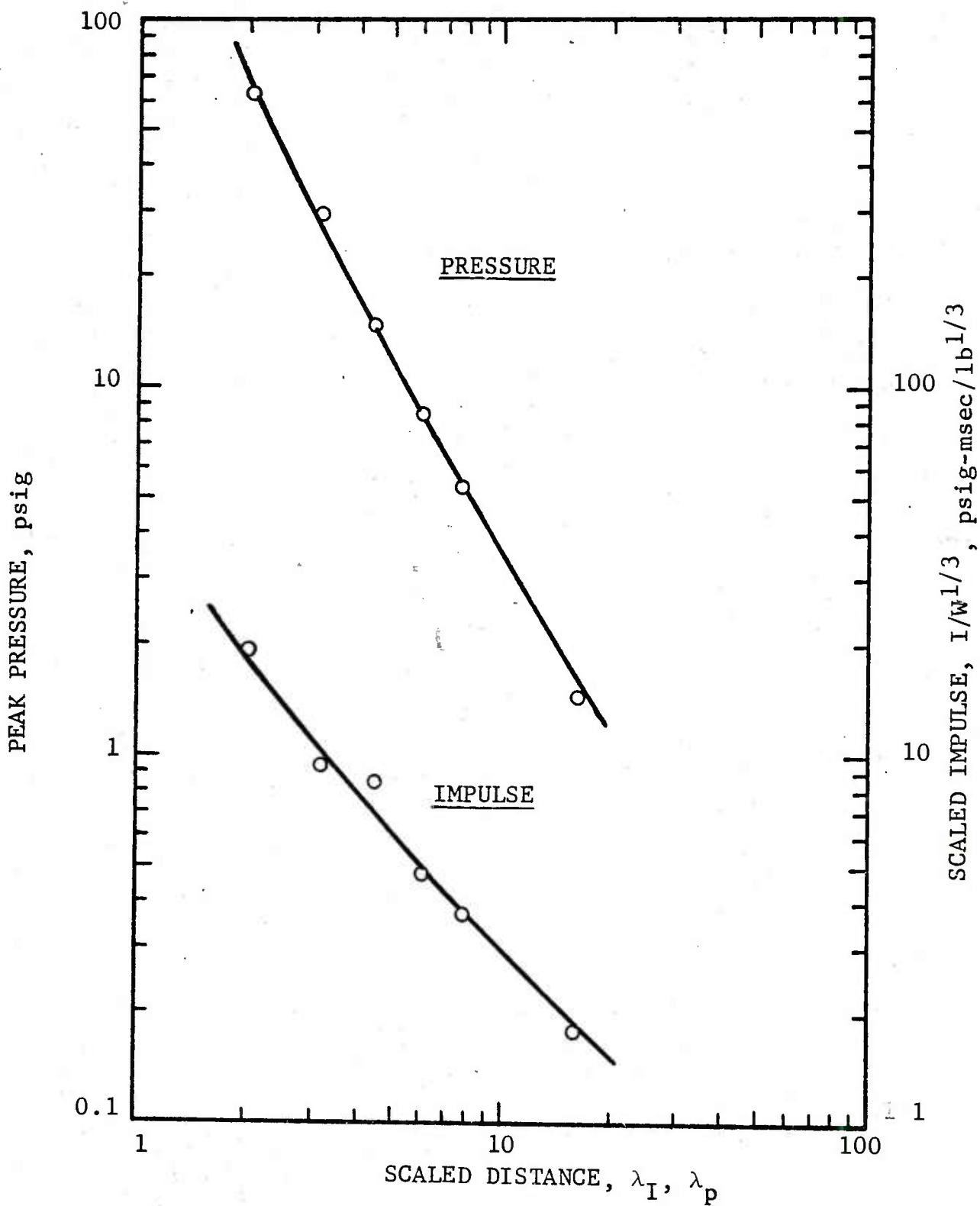

Figure A.27 PRESSURE AND IMPULSE; TEST BO-37
 25 lb BLACK POWDER, 0.54 lb PBX BOOSTER

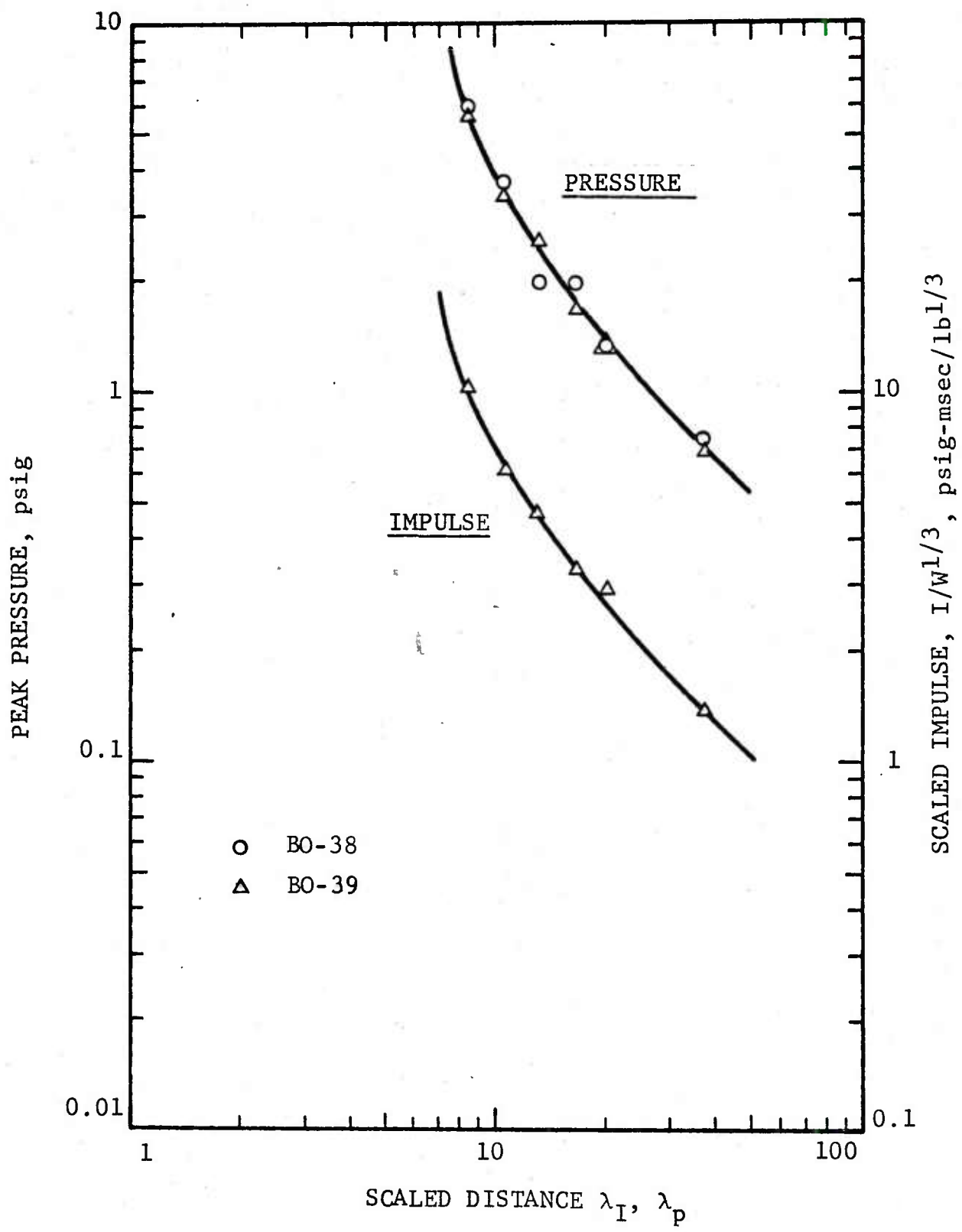

Figure A.28 PRESSURE AND IMPULSE; TESTS BO-38,39
INERT CHARGE, 3.00 lb C4 BOOSTER

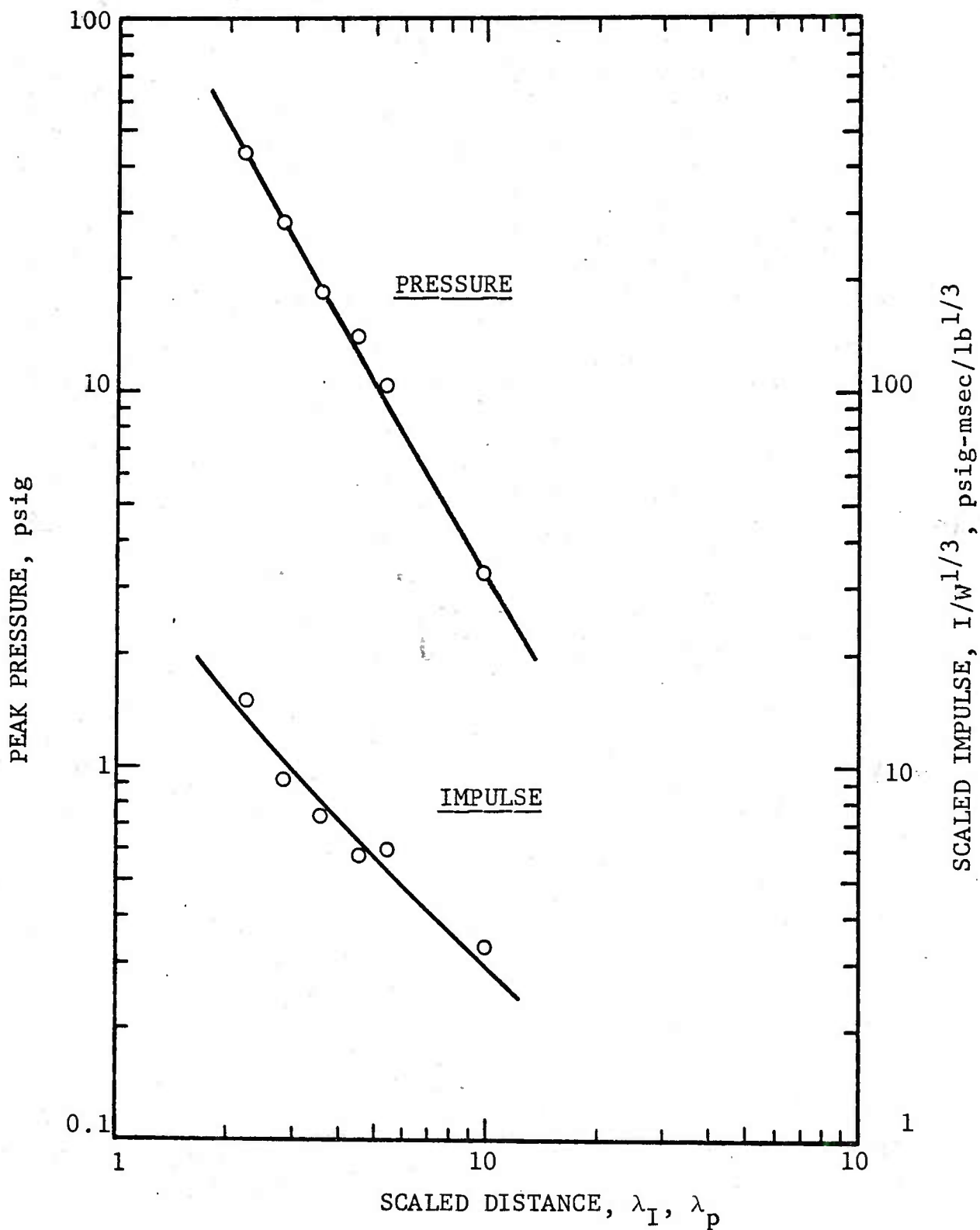

Figure A.29

PRESSURE AND IMPULSE; TEST BO-40
 150 lb BLACK POWDER, 1.50 lb C4 BOOSTER

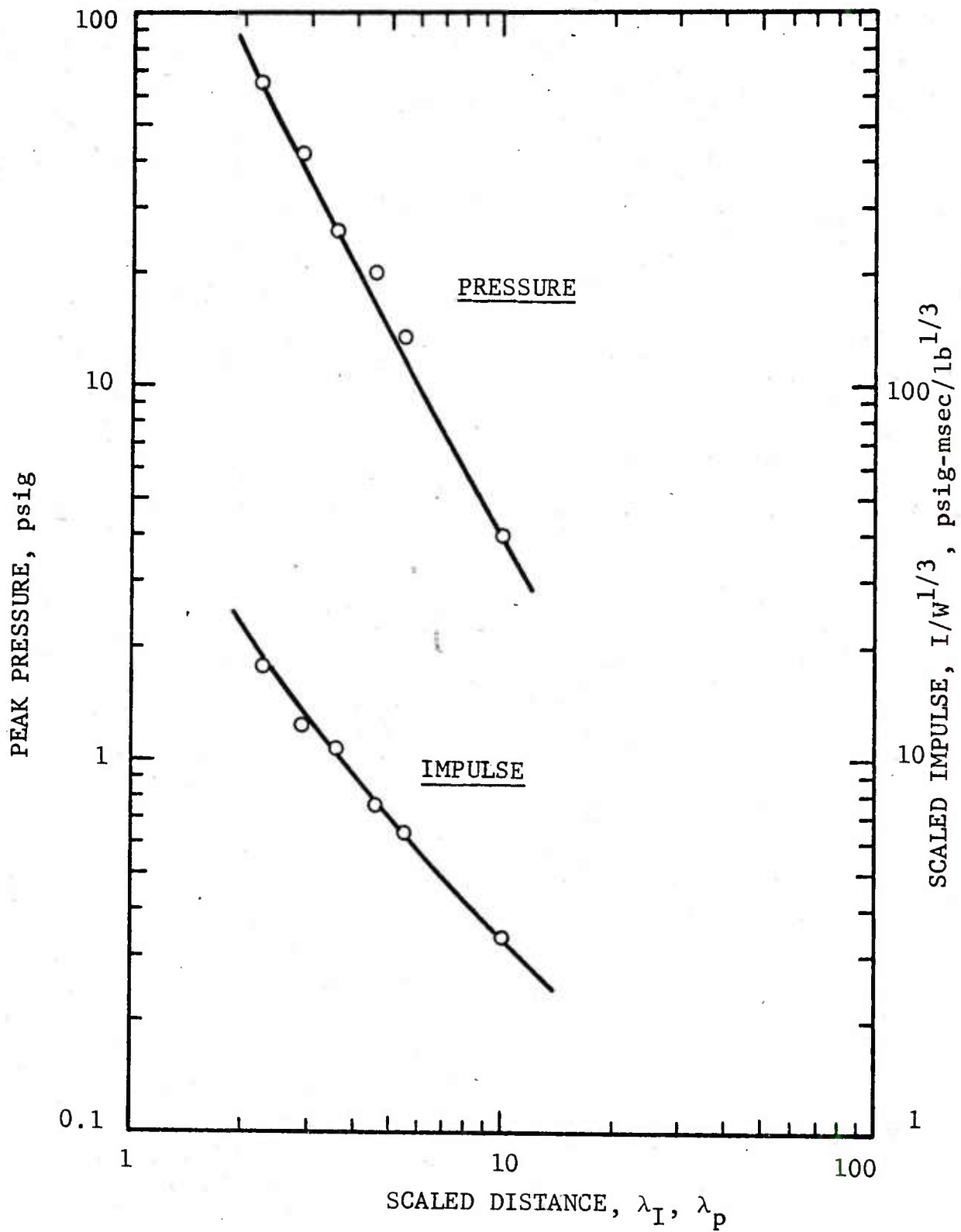

Figure A.30 PRESSURE AND IMPULSE; TEST BO-41
 150 lb BLACK POWDER, 3.00 lb C4 BOOSTER
 A-43

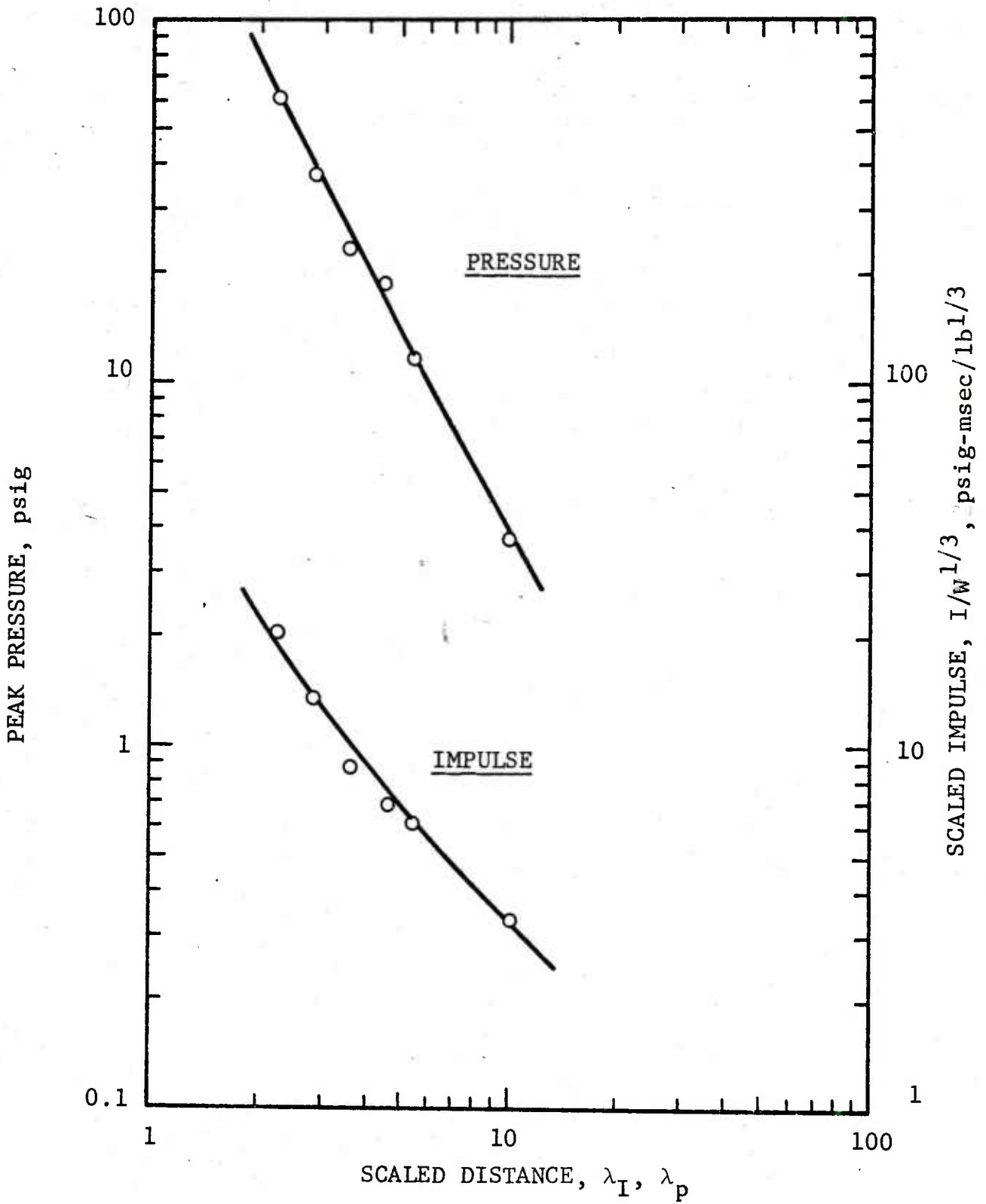

Figure A.31 PRESSURE AND IMPULSE; TEST BO-42
 150 lb BLACK POWDER, 3.00 lb C4 BOOSTER

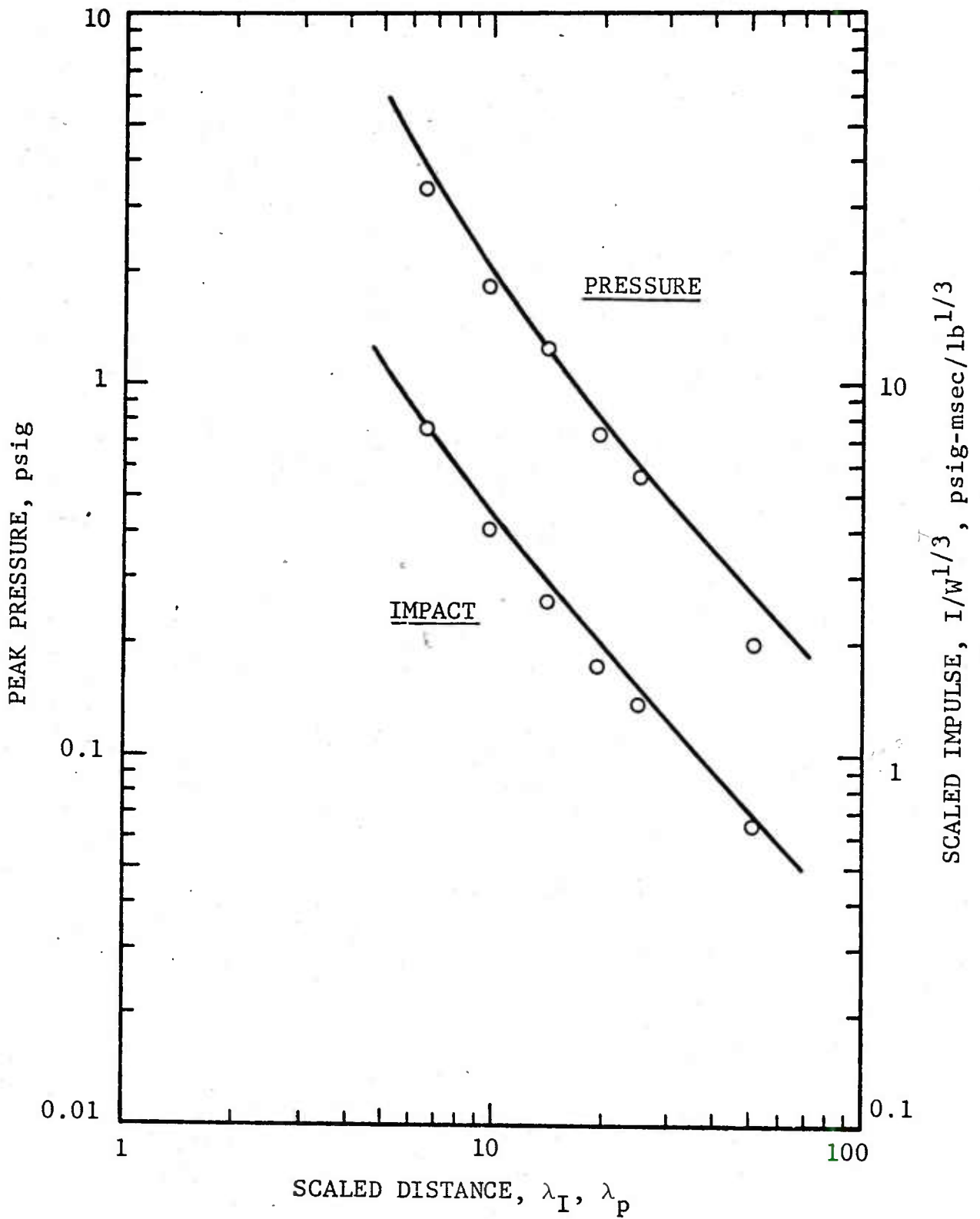

Figure A.32 PRESSURE AND IMPULSE; TEST BO-43
INERT CHARGE, 0.50 lb C4 BOOSTER

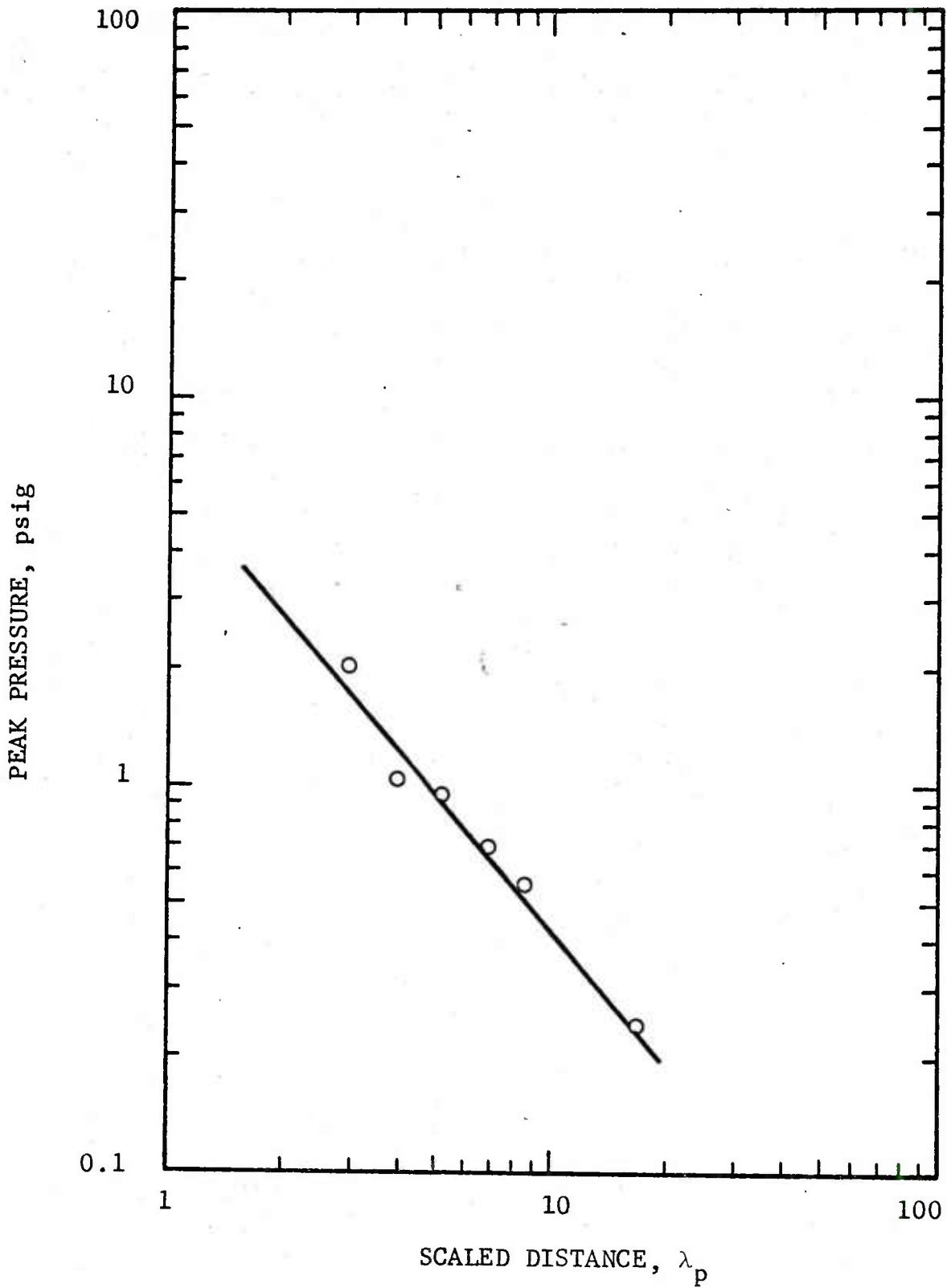

Figure A.33

PRESSURE; TEST UNC-1
 27 1b BLACK POWDER, 0.024 1b TETRYL BOOSTER

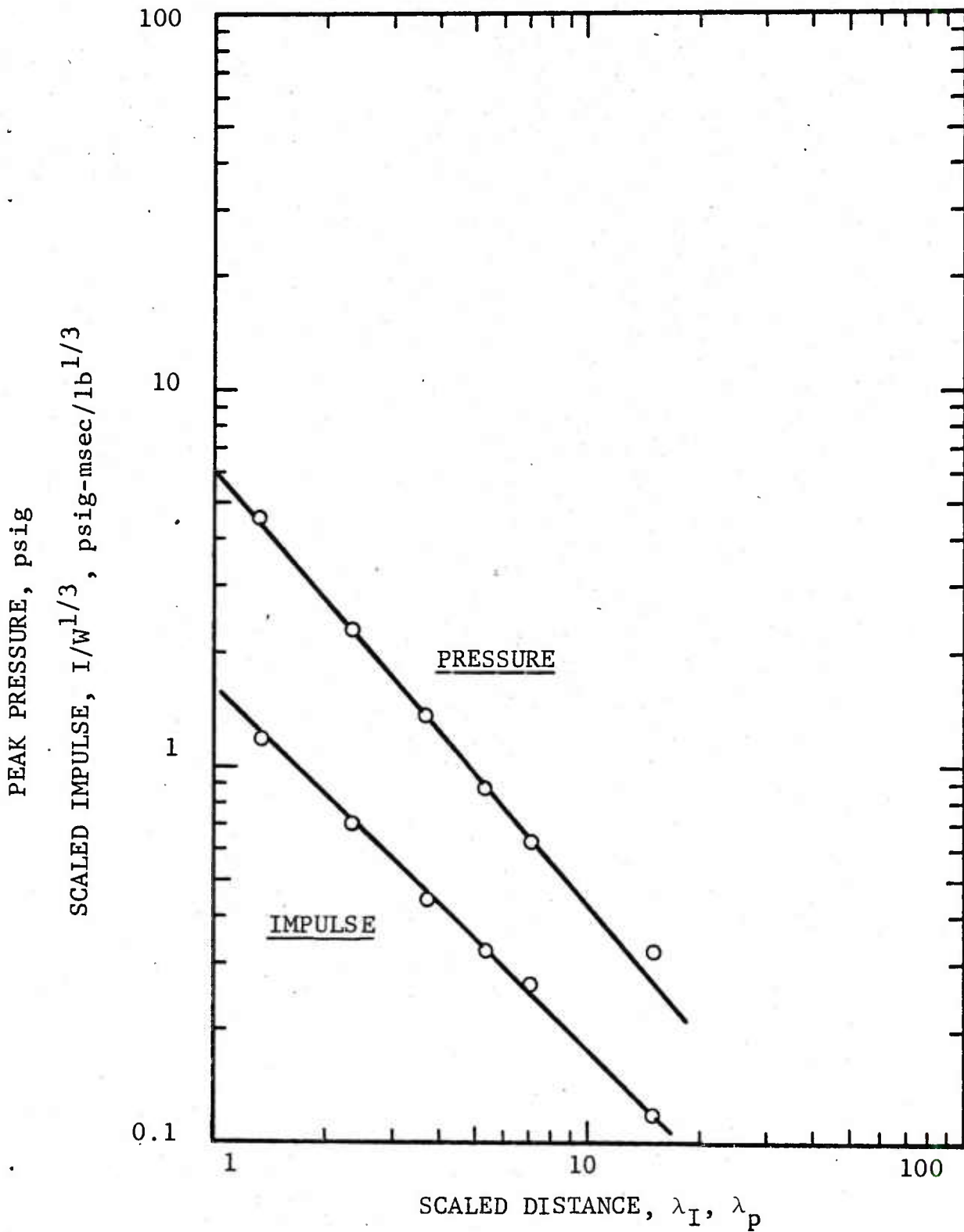

Figure A.34

PRESSURE AND IMPULSE; TEST UNC-2
 27 lb BLACK POWDER, 0.024 lb TETRYL BOOSTER

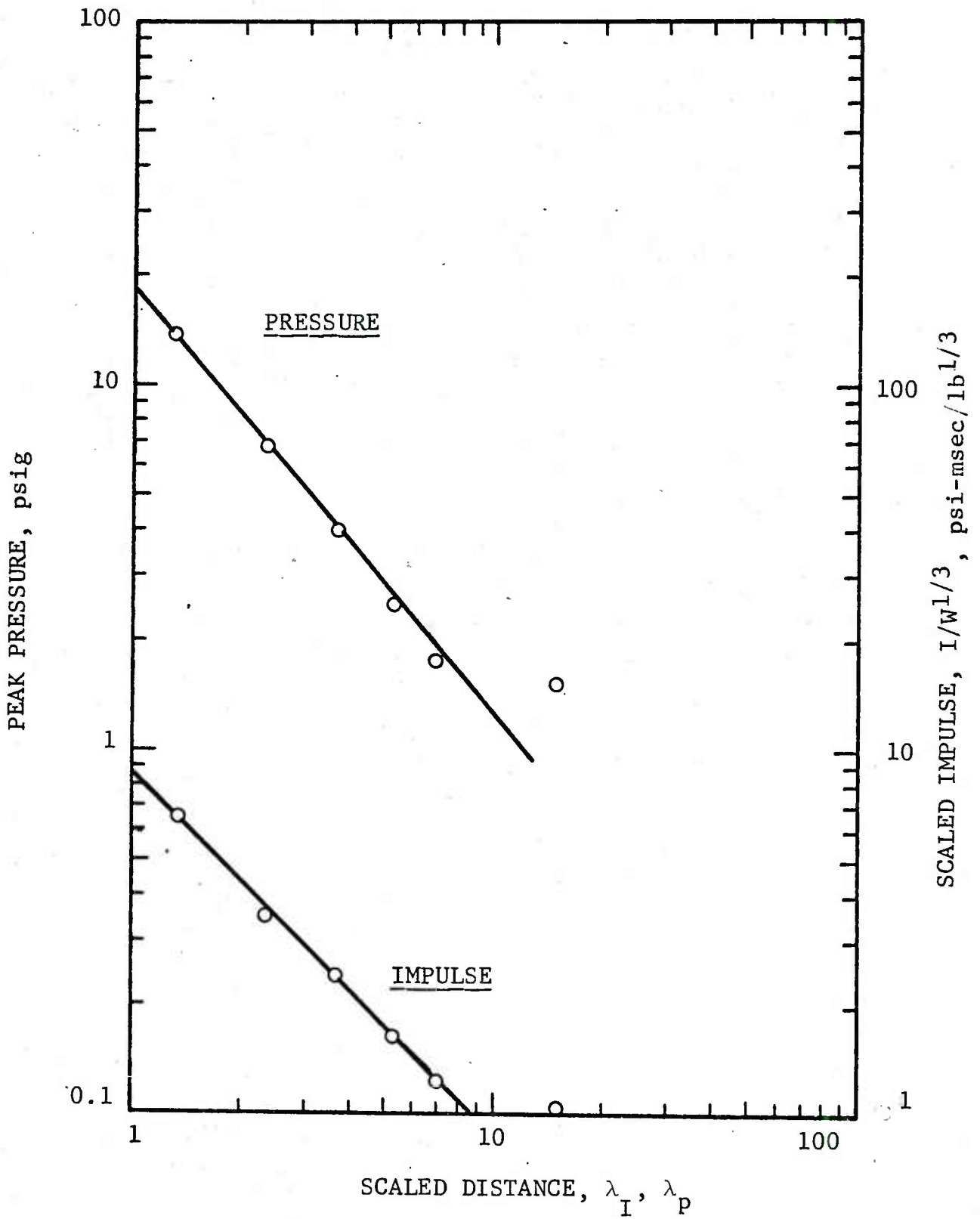

Figure A.35

PRESSURE AND IMPULSE; TEST UNC-5
 27 lb BLACK POWDER, 0.024 lb TETRYL BOOSTER

27² UNC 5

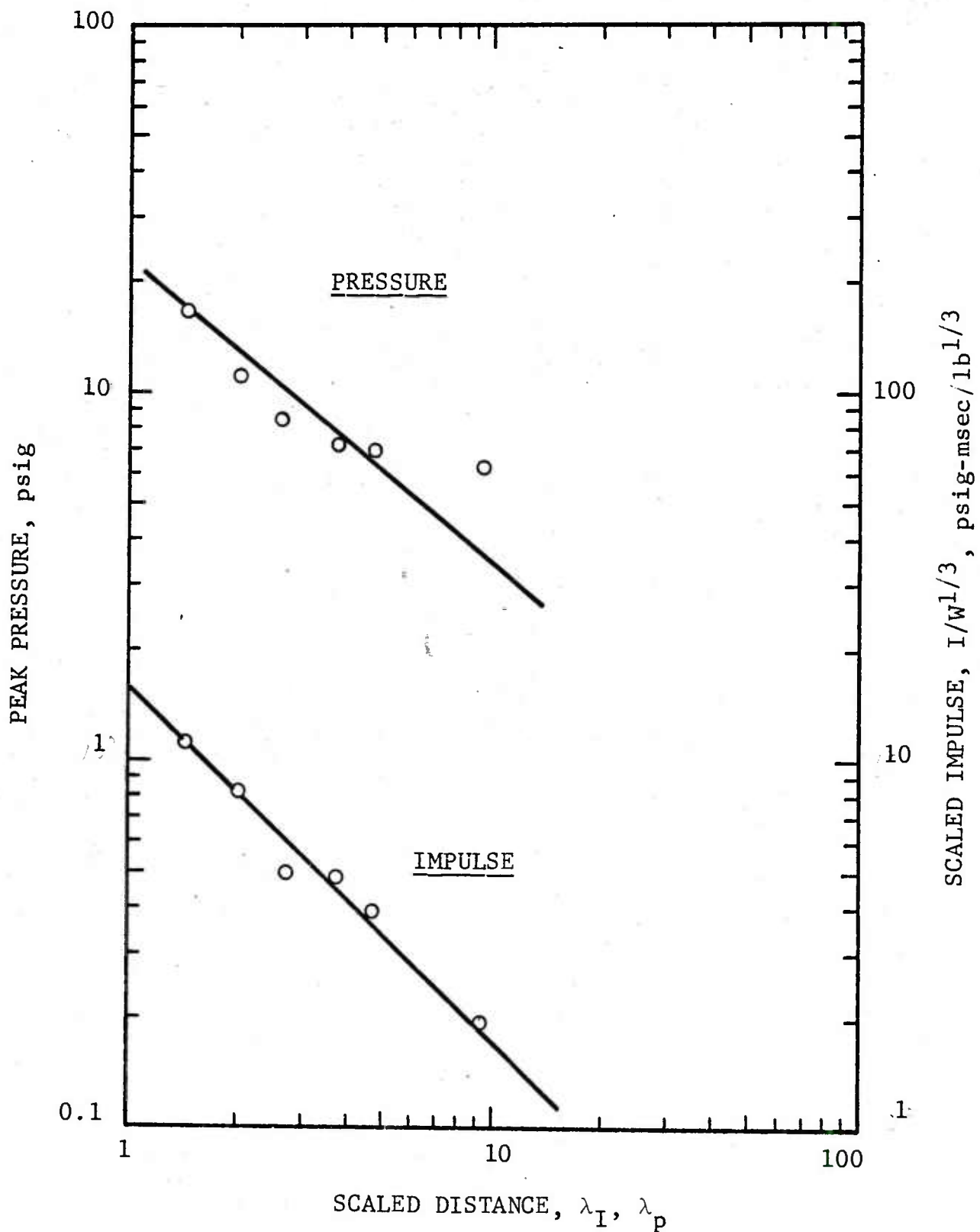

Figure A.36

PRESSURE AND IMPULSE; TEST UNC-6
 140 lb BLACK POWDER, 0 024 lb TETRYL BOOSTER

140 # 024

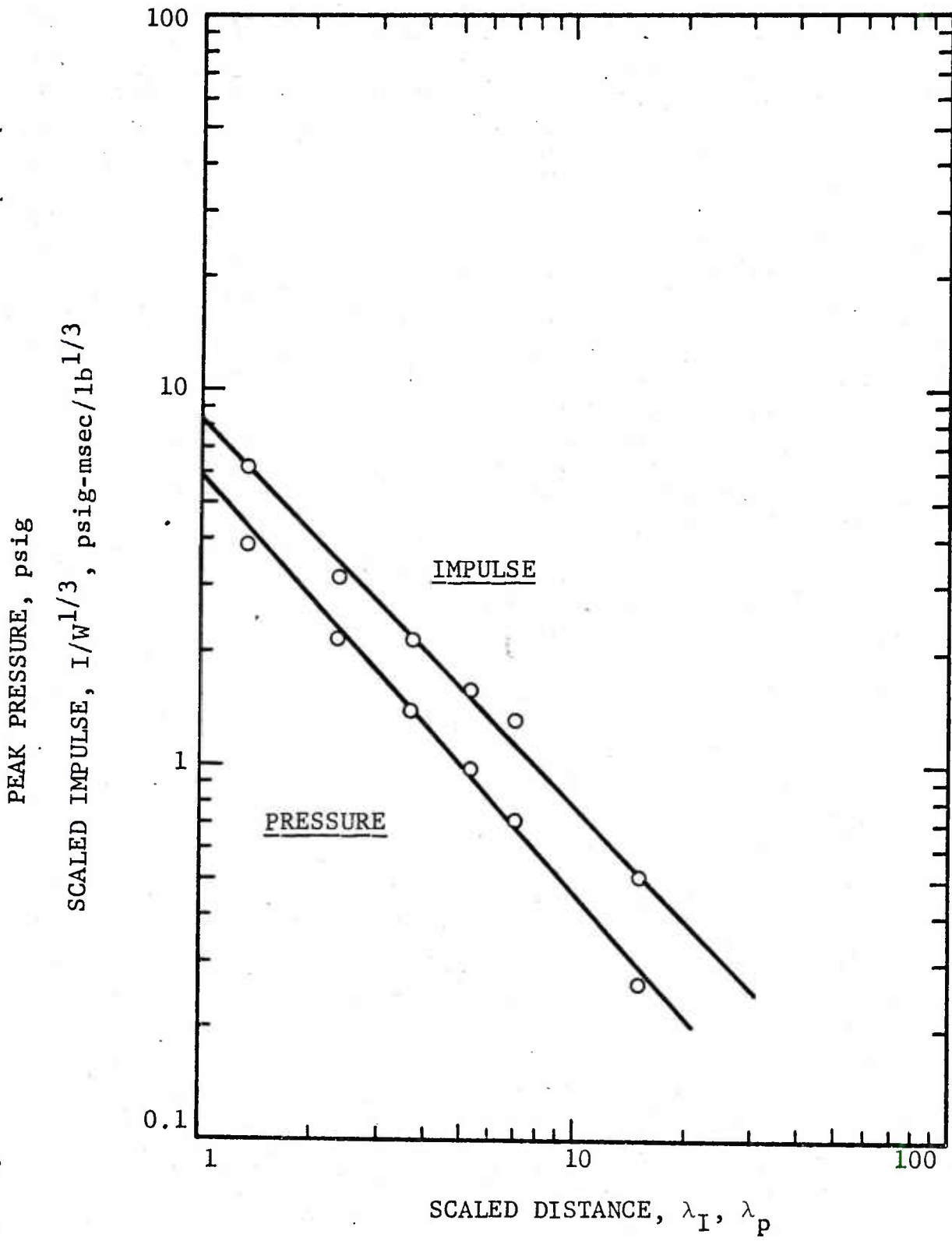

Figure A.37 PRESSURE AND IMPULSE; TEST UNC-9
 27 lb JET MILLED MATERIAL, 0.024 lb TETRYL BOOSTER

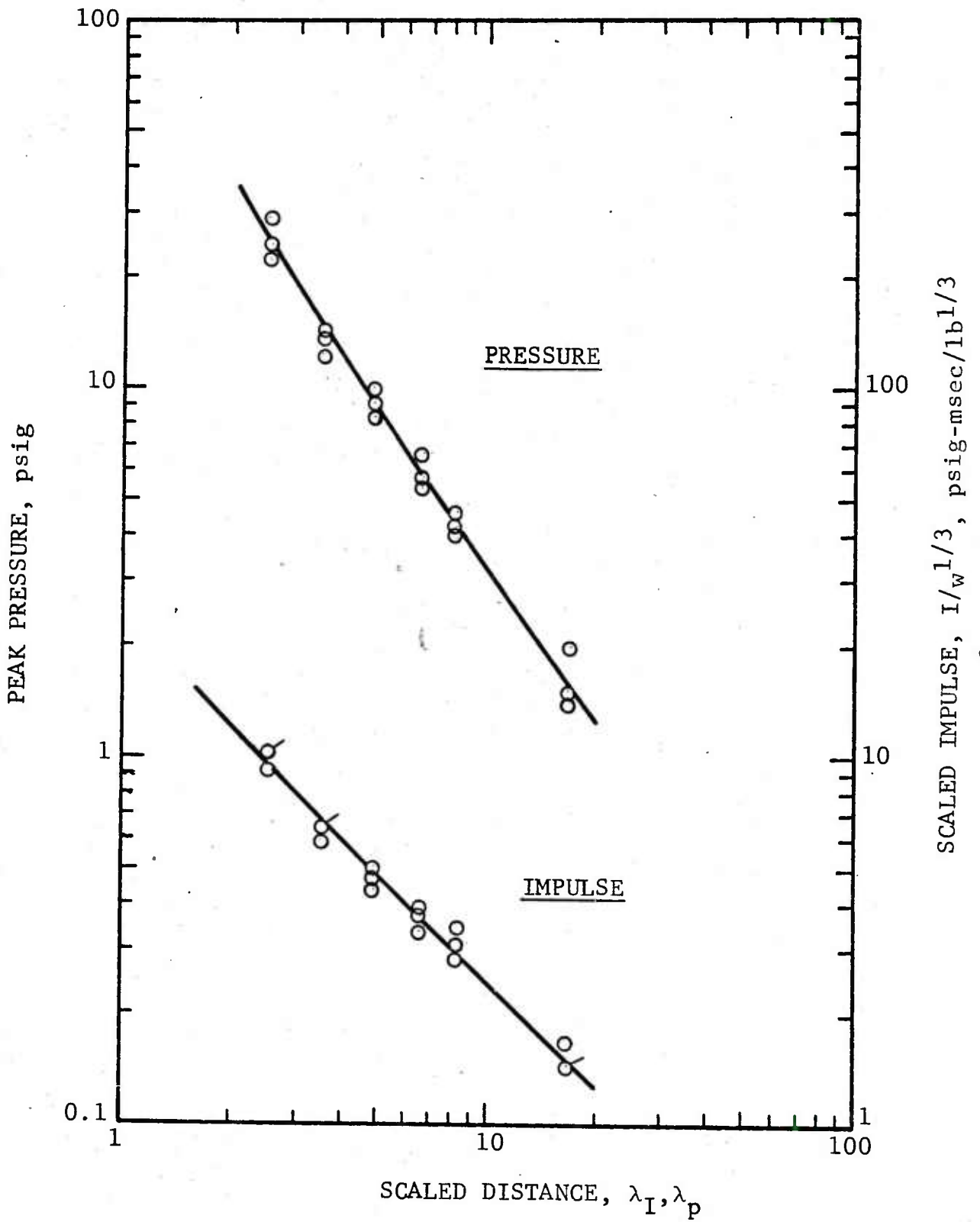

Figure A.38

PRESSURE AND IMPULSE; TESTS CON-3,4,5
 27 lb BLACK POWDER, 0.024 lb TETRYL BOOSTER

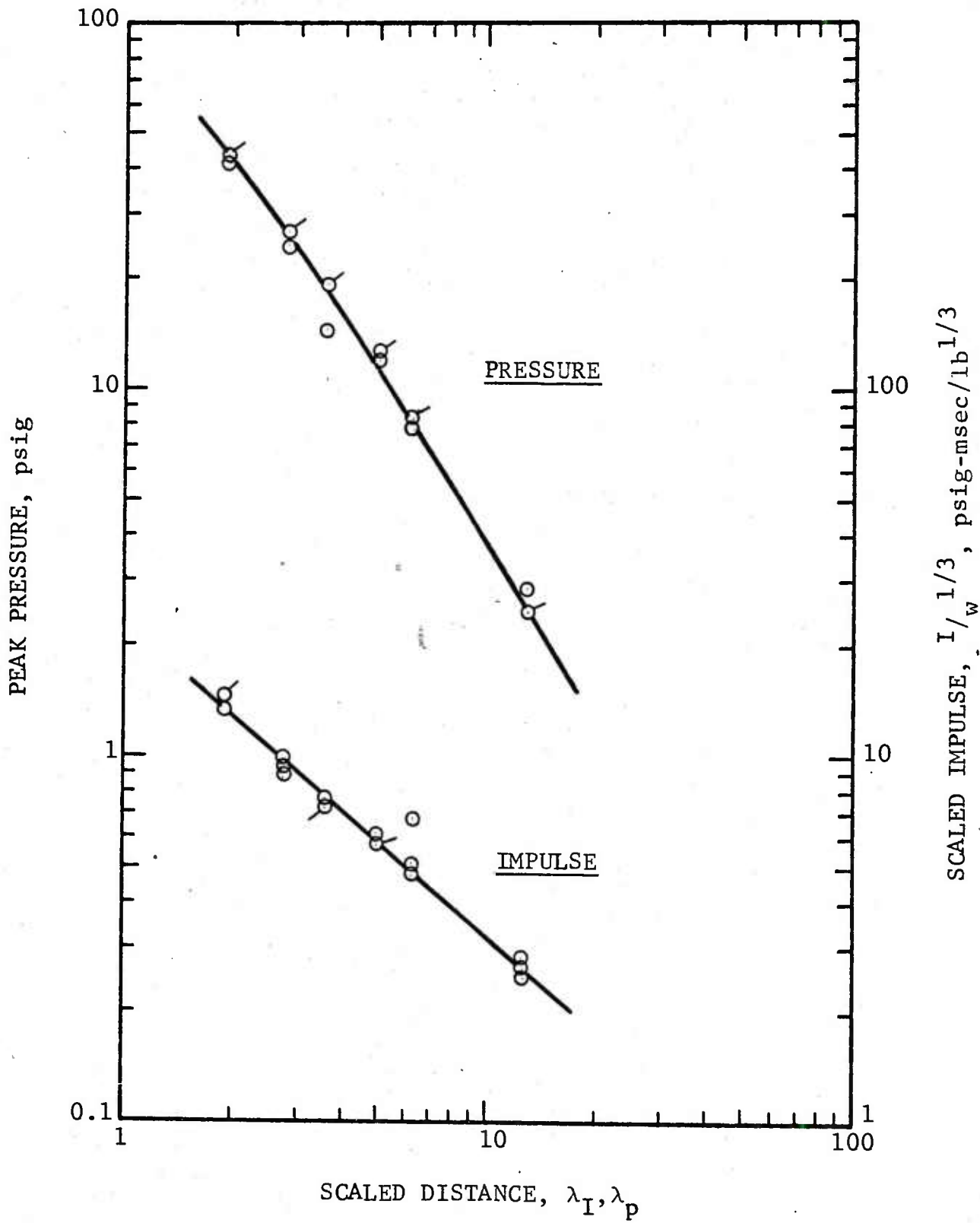

Figure A.39 PRESSURE AND IMPULSE; TESTS CON-6,7,8
64 lb BLACK POWDER, 0.024 lb TETRYL BOOSTER

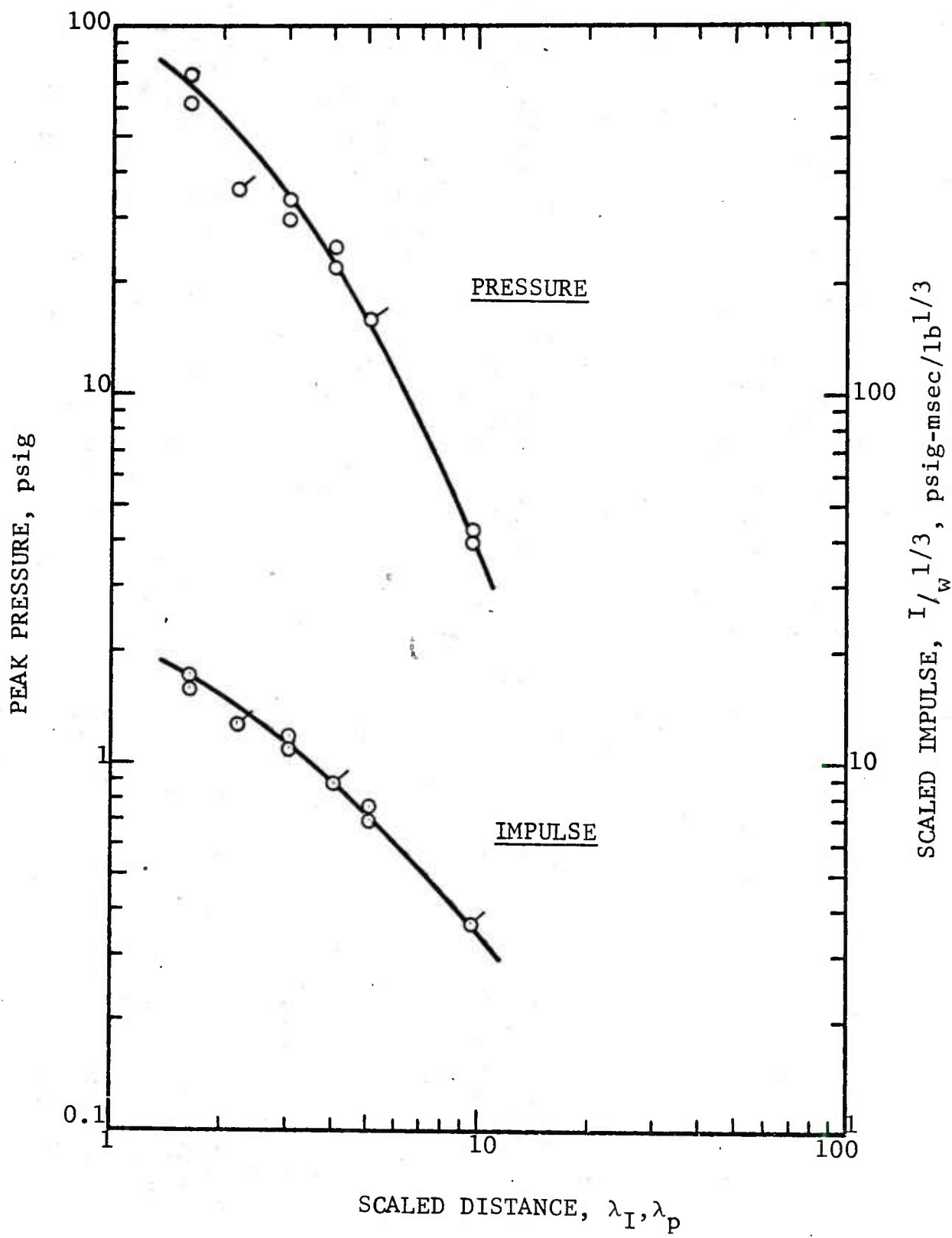

Figure A.40

PRESSURE AND IMPULSE; TESTS CON-9,10
 140 lb BLACK POWDER, 0.024 lb TETRYL BOOSTER

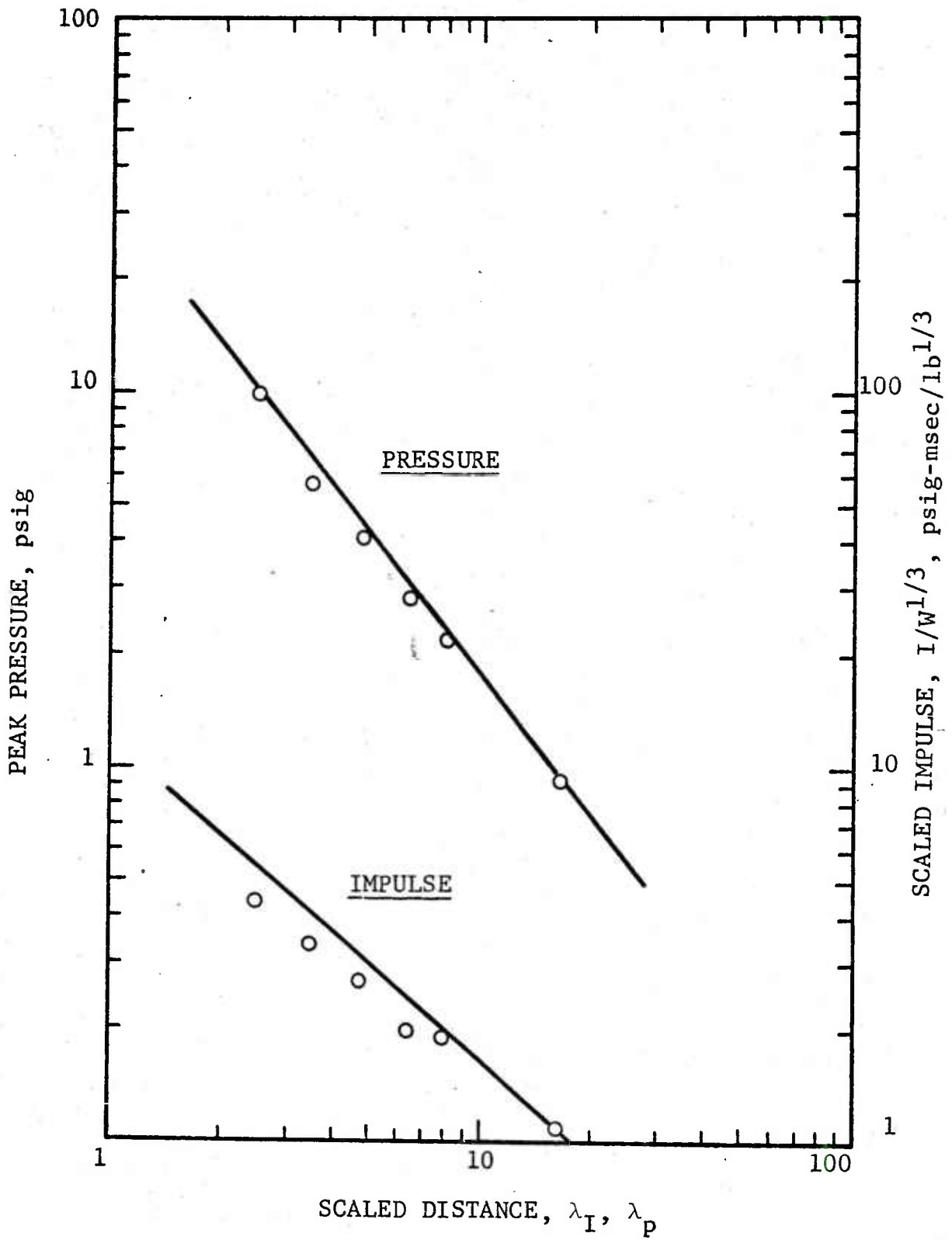

Figure A.41

PRESSURE AND IMPULSE; TEST CON-12
 27 lb JET MILLED MATERIAL, 0.024 lb TETRYL BOOSTER

27 " CON 11

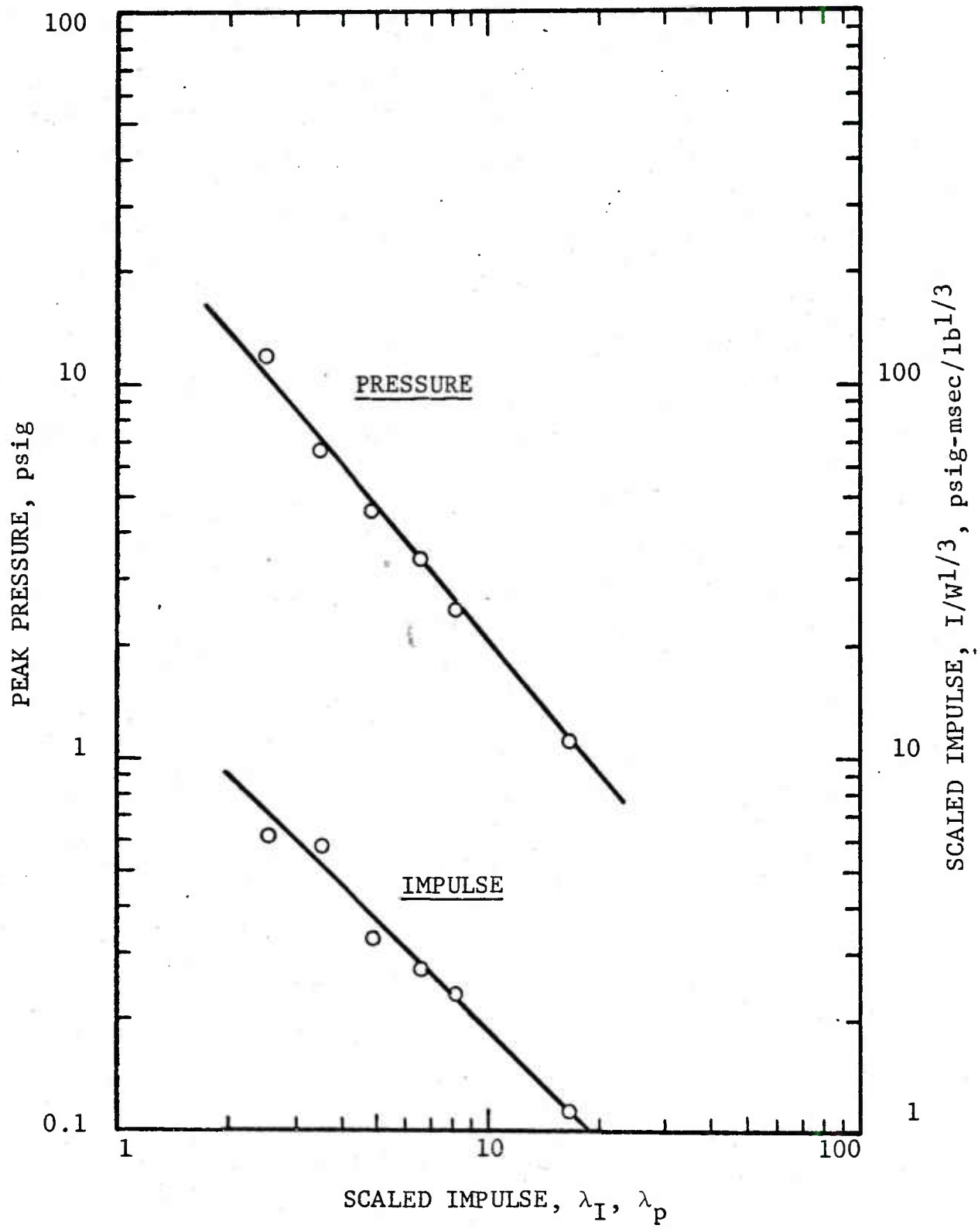

Figure A.42 PRESSURE AND IMPULSE; TEST CON-12
 27 lb JET MILLED MATERIAL, 0.024 lb TETRYL BOOSTER

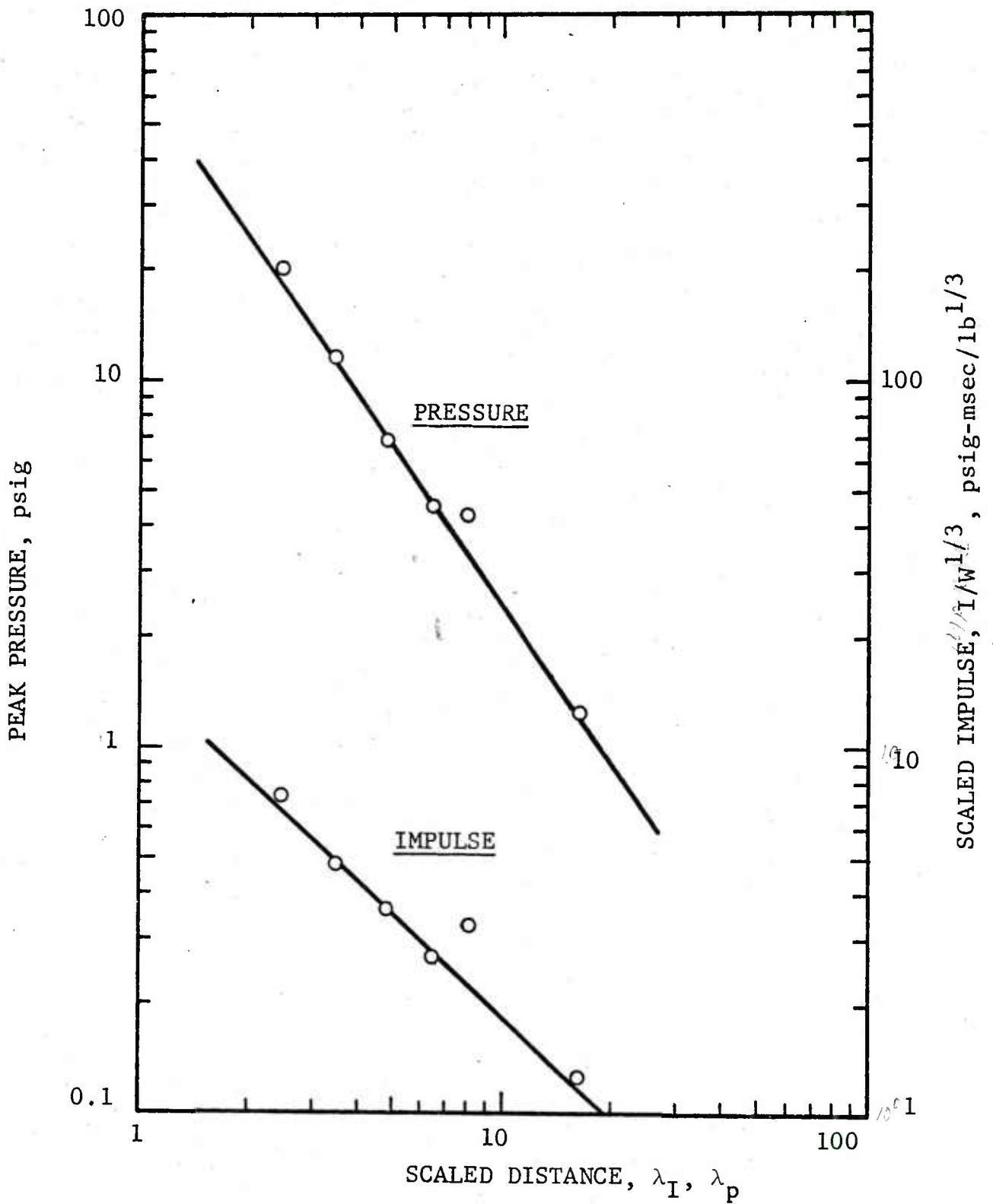

Figure A.43 PRESSURE AND IMPULSE; TEST SQ-1
 27 lb BLACK POWDER, SQUIB INITIATED

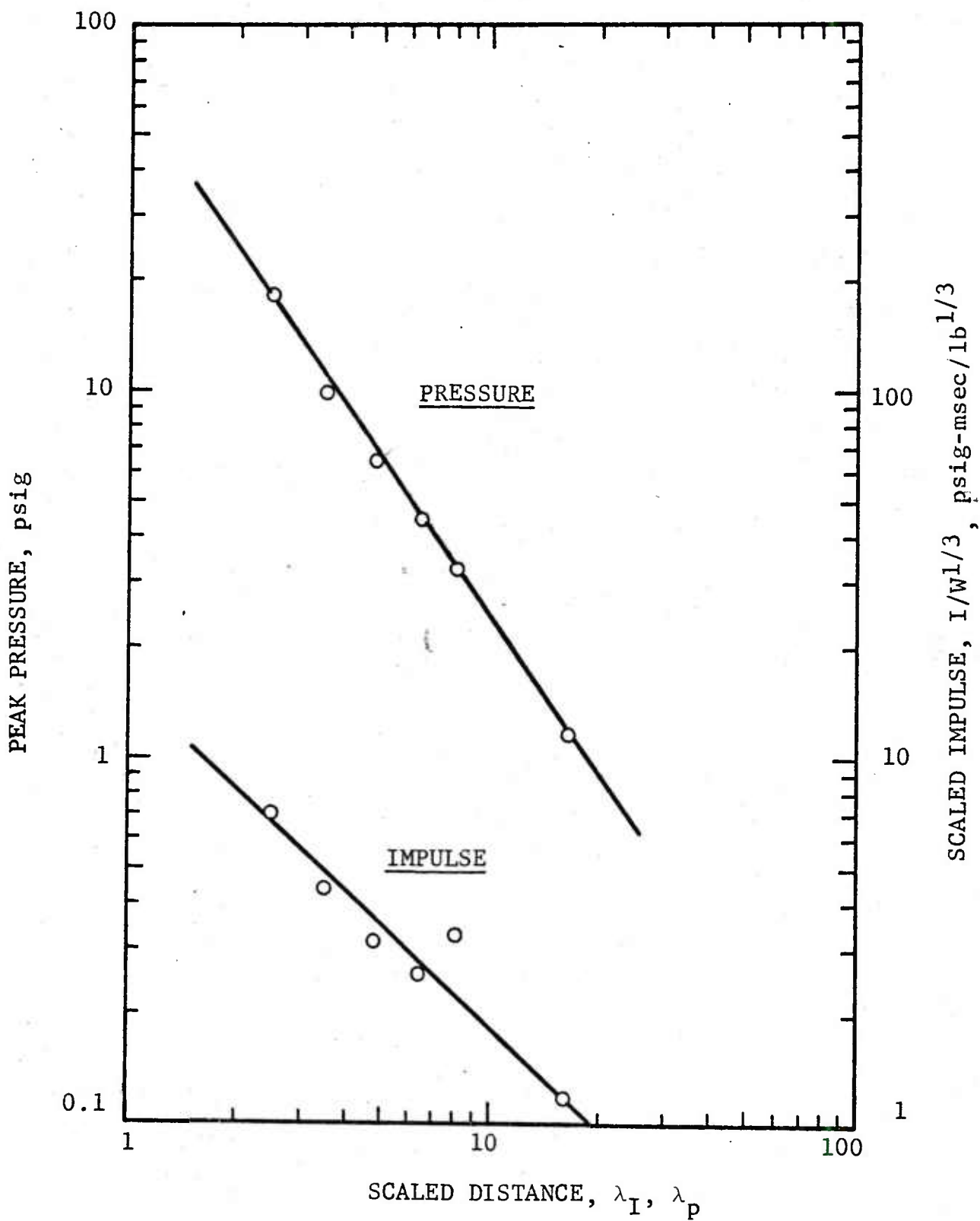

Figure A.44 PRESSURE AND IMPULSE; TEST SQ-2
27 lb BLACK POWDER, SQUIB INITIATED

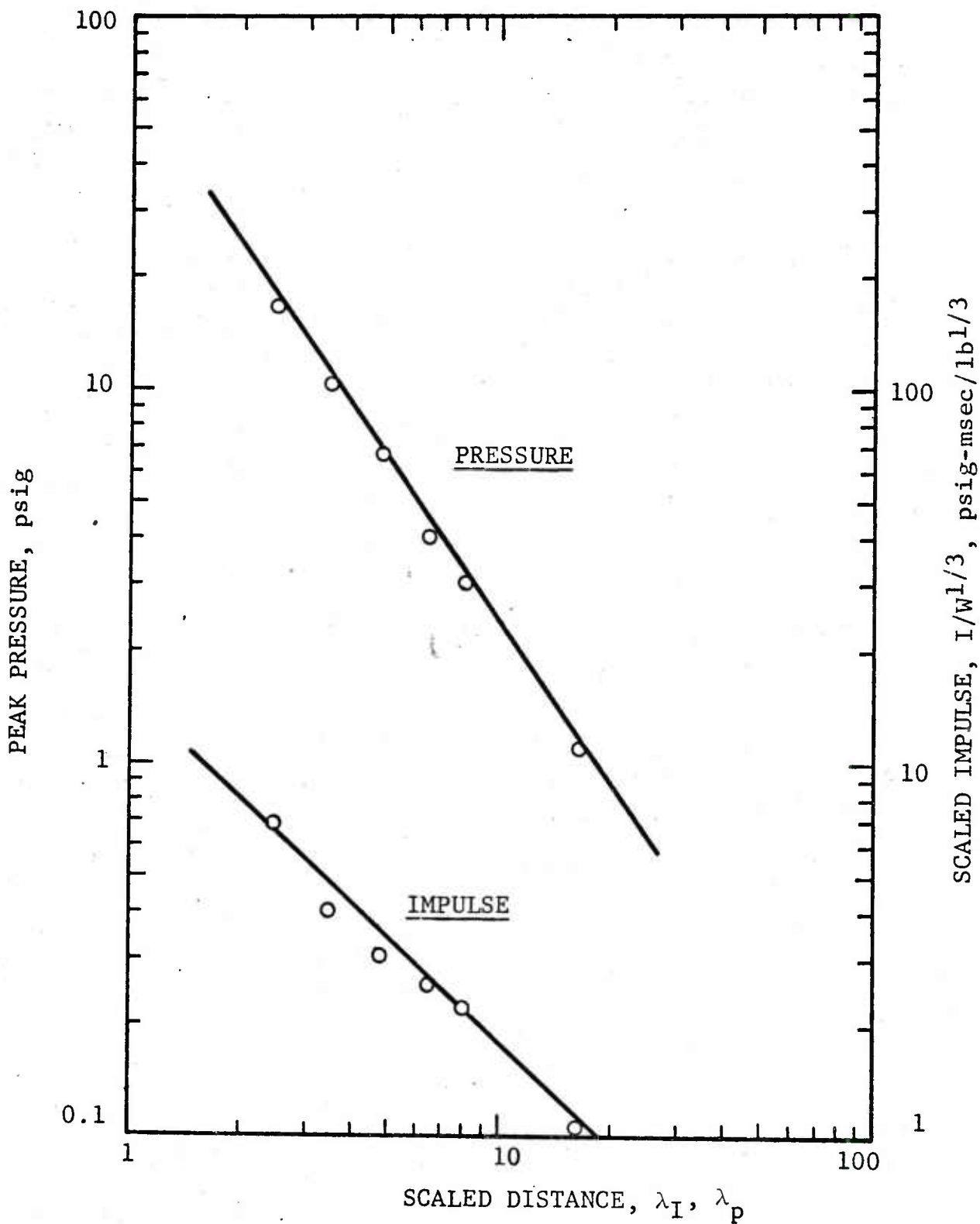

Figure A.45 PRESSURE AND IMPULSE; TEST SQ-3
27 lb BLACK POWDER, SQUIP INITIATED

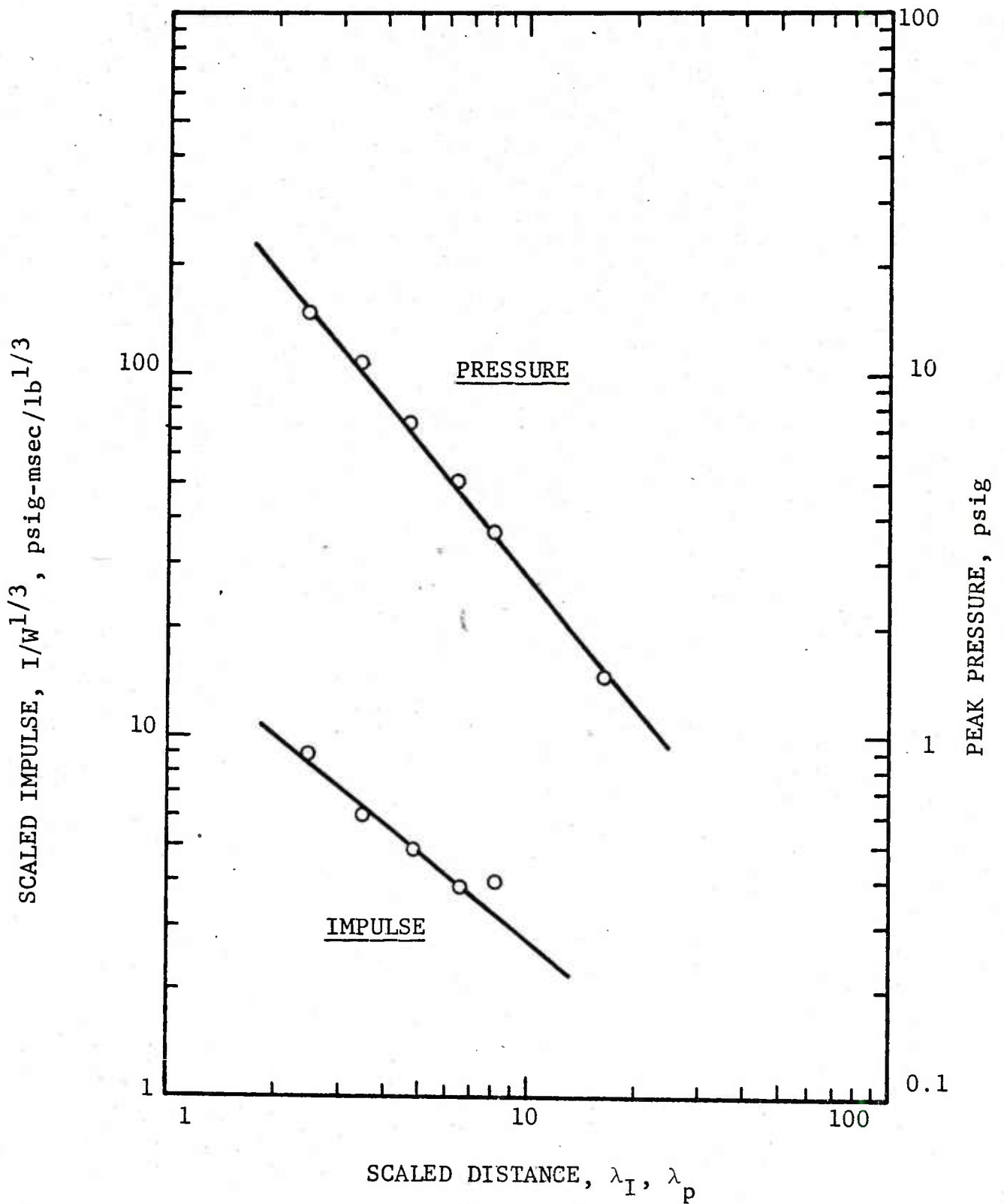

Figure A.46

PRESSURE AND IMPULSE; TEST SQ-4
 27 lb JET MILLED MATERIAL, SQUIB INITIATED

27 # SQ 4

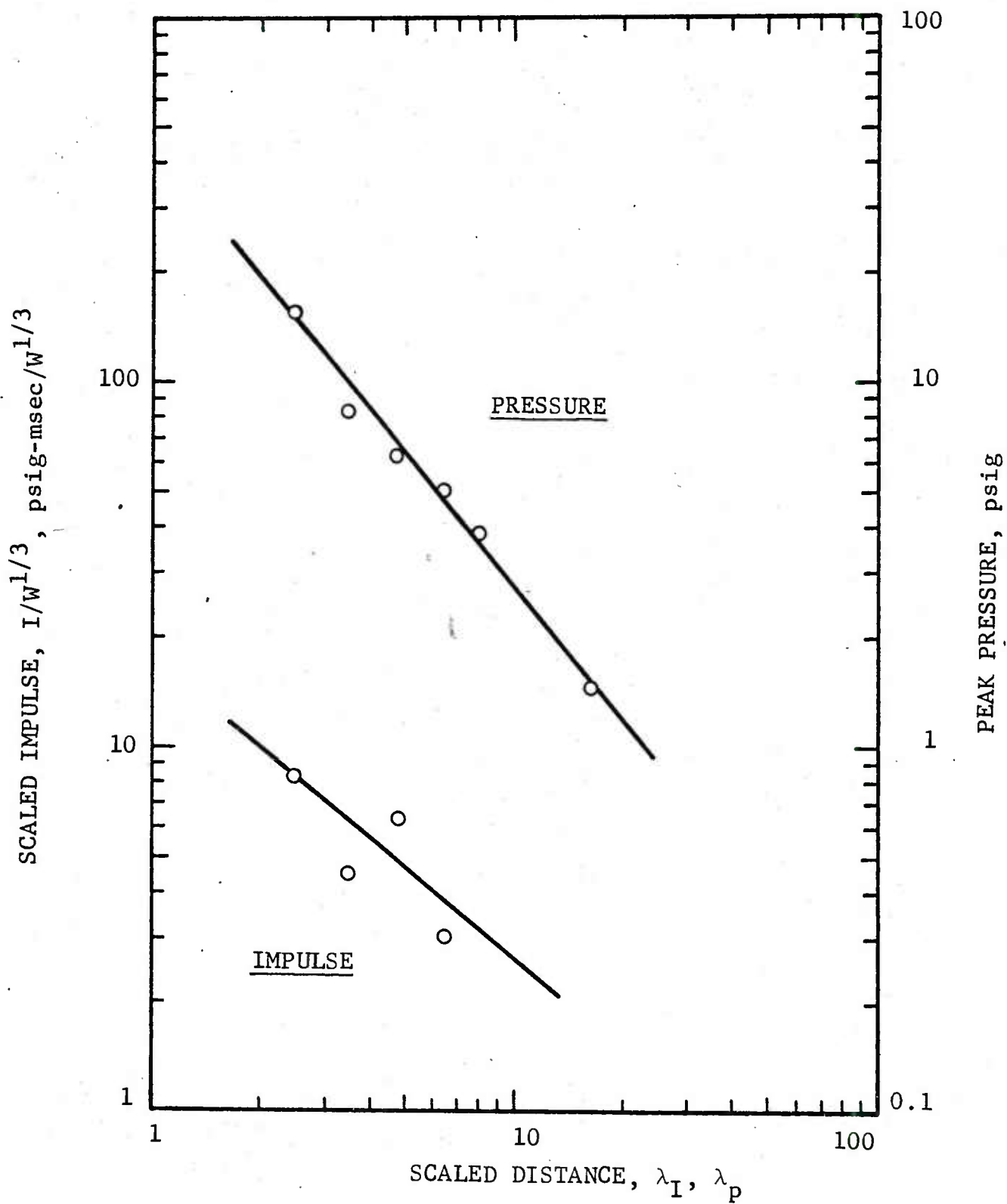

Figure A.47

PRESSURE AND IMPULSE; TEST SQ-5
 27 1b JET MILLED MATERIAL, SQUIB INITIATED

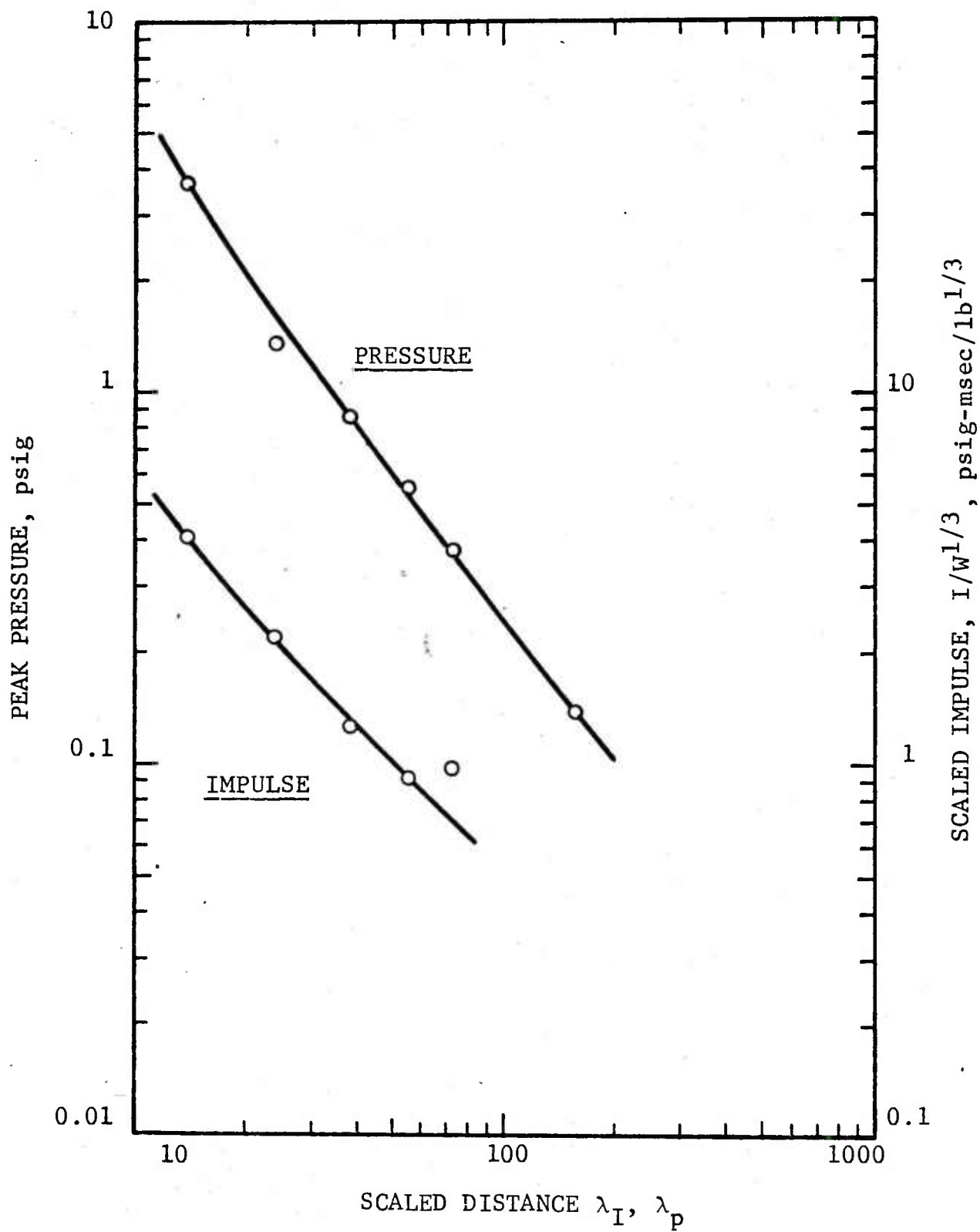

Figure A.48

PRESSURE AND IMPULSE; TEST CAL-3
INERT CHARGE, 0.024 lb TETRYL BOOSTER

APPENDIX B

TNT EQUIVALENCY CALCULATION PROCEDURE

APPENDIX B
TNT EQUIVALENCY CALCULATION PROCEDURE

CONTENTS

		<u>Page</u>
B.1	Computational Procedure	B-1
B.2	Computerized Calculations	B-6
B.3	Sample Problem	B-7

FIGURES

B.1	TNT Pressure and Impulse	B-3
-----	--------------------------	-----

B.1 COMPUTATIONAL PROCEDURE

The computational procedure used to obtain TNT equivalencies is illustrated in this appendix. TNT equivalency for pressure is defined as the ratio of charge weight (i.e., TNT weight/test explosive weight) that will give the same peak pressure at the same radial distance from each charge. Similarly, the TNT equivalency for impulse is defined as the ratio of charge weights that will give the same positive impulse at the same radial distances. Since the booster, used to detonate the test explosive, propellant, or pyrotechnic may be of the order of 10 percent of the test material weight it is necessary to account for its contribution to the explosive output (i.e., peak pressure and impulse).

The symbols used in this discussion are:

W	Weight, lbs
R	Radial distance from charge, ft
$\lambda = R/W^{1/3}$	Scaled distance, ft/lb ^{1/3}
P	Peak overpressure, psig
I	Positive impulse, psi-msec
E	TNT equivalency, percent

These subscripts and superscripts are self-explanatory when applied to the above symbols:

S	Test sample
B	Booster
TNT	TNT explosive
I	Impulse
P	Pressure
*	Quantity is not adjusted for booster weight
TOT	Total charge weight, booster plus sample

Pressure equivalency is determined by first measuring the quantities W_s , R, and P_{SB} . Where P_{SB} is the peak pressure measured when the sample, black powder or jet milled material, was detonated with a C4 booster, it includes an energy contribution from both C4 and sample.

One must first approximate an equivalent booster weight, in terms of the Black Powder charge sample weight, so that its weight can be included in the total charge weight. The approximation is found by obtaining λ_{TNT} , from Figure B1, for $P_{\text{SB}} = P_{\text{TNT}}$.

The first approximation for TNT pressure equivalency is then

$$E_p^* = (\lambda_s / \lambda_{\text{TNT}})^3 = W_{\text{TNT}} / W_s$$

where

$$\lambda_s = R / W_s^{1/3}$$

and

$$\lambda_{\text{TNT}} = R / W_{\text{TNT}}^{1/3}$$

Since the pressures are to be equal at the same radial distance, the R's cancel in the above equation. One applies this approximated equivalency, E_p^* , to the weight of the booster to obtain the total charge weight

$$W_{\text{TOT}} = W_s + (1/E_p^*) W_B \quad (1.25).$$

A factor of 1.25 is applied to the C4 booster weight to obtain its equivalent TNT weight.

A new λ is now computed from

$$\lambda_{\text{TOT}} = R / W_{\text{TOT}}^{1/3}$$

and a corrected pressure TNT equivalency is computed.

$$E_p = W_{\text{TNT}} / W_{\text{TOT}} = (\lambda_{\text{TOT}} / \lambda_{\text{TNT}})^3$$

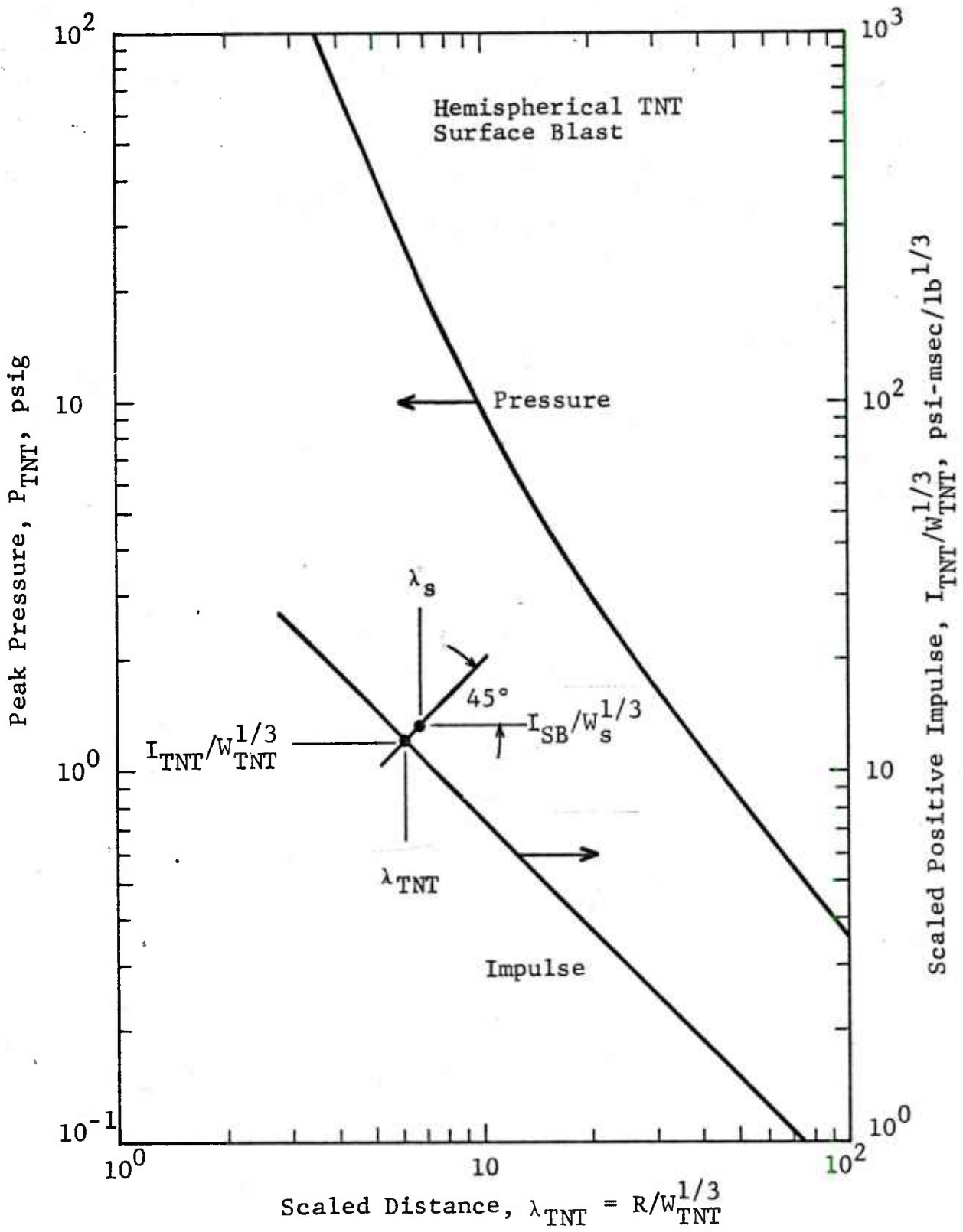

Figure B1 TNT PRESSURE AND IMPULSE

The P subscript indicates a scale distance for pressure and is computed from the revised sample weight. This iterative process can be repeated using the revised value of E_p to recompute the weight of the booster in terms of the sample weight, etc. However the second iteration has a small effect on equivalency.

Impulse equivalency is determined by first measuring W_s , R , and I_{SB} . Where I_{SB} is the impulse measured when the sample Black Powder charge, was detonated with a C4 booster. One must first approximate an equivalent booster weight, in terms of the Black Powder charge sample weight, so that its weight can be included in the total charge weight. The approximation is found by locating the data point $I_{SB}/W_s^{1/3}$: λ_s on Figure B1. A 45 deg line is drawn through this data point to intersect with the TNT impulse curve. Values of λ_{TNT} and $I_{TNT}/W_{TNT}^{1/3}$ are read at the intersection of the two straight lines. These values give the equivalent TNT weight for equal impulses and radial distances.

At the data point $I_{SB}/W_s^{1/3}$ and λ_s let

$$a_s = I_{SB}/W_s^{1/3} \text{ or } I_{SB} = a_s W_s^{1/3}$$

and

$$\lambda_s = R/W_s^{1/3} \text{ or } R = \lambda_s W_s^{1/3}.$$

For equal impulses

$$a_s W_s^{1/3} = a_{TNT} W_{TNT}^{1/3}$$

or

$$I_{SB} = I_{TNT}$$

and for equal radial distances

$$\lambda_s W_s^{1/3} = \lambda_{TNT} W_{TNT}^{1/3}.$$

Divide these two equations and get

$$\frac{a_s}{a_{TNT}} = \frac{\lambda_s}{\lambda_{TNT}}$$

Take the log of the above equation

$$\log a_s - \log a_{TNT} = \log \lambda_s - \log \lambda_{TNT}.$$

This equation shows that a 45 deg construction line on log-log paper will intersect the impulse curve and data point in such a way as to satisfy the conditions of equal positive impulses at the same radial distance.

The first approximation for TNT impulse equivalency is

$$E_I^* = W_{TNT}/W_s$$

$$E_I^* = (I_{SB}/W_s^{1/3})^3 / (I_{TNT}/W_{TNT}^{1/3})^3$$

Since $I_{SB} = I_{TNT}$ they cancel in the above equation.

One applies this approximated equivalency, E_I^* , to the weight of the booster to obtain the total charge weight

$$W_{TOT} = W_s + (1/E_I^*) W_B \quad (1.25).$$

A new scaled distance

$$\lambda_{TOT} = R/W_{TOT}^{1/3}$$

and scaled impulse is then computed

$$I_{SB}/W_{TOT}^{1/3}$$

This data point is now located on Figure C1 and new $I_{TNT}/W_{TNT}^{1/3}$ and λ_{TNT} values are determined from the 45 deg line intersection method described.

The corrected impulse equivalency then becomes

$$E_I = W_{TNT}/W_{TOT}$$

$$E_I = (I_{SB}/W_{TOT}^{1/3})^3 / (I_{TNT}/W_{TNT}^{1/3})^3.$$

B.2 Computerized Calculations

The procedures outlined in the preceding section have been programmed so that they may be performed by means of a digital computer. Since the experimental data usually exhibits some scatter, smoothing of the data is performed before TNT equivalencies are computed. The first step in the smoothing is accomplished by averaging the pressure-distance (or impulse-distance) test data obtained under identical conditions in multiple experiments. The averaged experimental data points are then curve fitted in the log-log plane, i.e. $\log P = F(\log \lambda)$ etc. Polynomial fits of first or second order are employed. The best curve fitted to the data points is selected. It is this fitted curve which is subsequently employed in the computer calculations to determine the TNT equivalency at distances from the charge that represent the six gage station locations.

The best curve fitted to the data points is based on that polynomial where the deviations of the data point from the curve is less than 10 percent. If a point has more than a 10 percent deviation, both the pressure and impulse values are rejected. After a point is rejected the curve fit calculations are repeated and a new curve to fit the remaining data points is derived.

B.3 SAMPLE PROBLEM

Test B0 - 16 was used for computing the TNT Pressure Equivalency.

$$W_S = 75 \text{ lb Black Powder}$$

$$W_{C4} = 0.50 \text{ lb}$$

$$R = 20.75 \text{ ft.}$$

$$P_{SB} = 8.16 \text{ psig}$$

Test B0-16 is selected to illustrate the method employed in obtaining the TNT equivalencies. This test gives the following measurements:

$$W_{B.P.} = 75 \text{ lbs.}$$

$$W_{C4} = 0.50 \text{ lb.}$$

$$R = 20.75 \text{ ft.}$$

$$I_{SB} = 18.5 \text{ psi-msec.}$$

$$P_{SB} = 8.16 \text{ psig}$$

Pressure Equivalency

For $P_{TNT} = P_{SB}$, a scaled distance (λ_{TNT}) of 10.9 ft/lb^{1/3} is obtained from Figure B1. The scaled distance at the datum point is found from

$$\lambda_{BP} = R/W_{BP}^{1/3} = 20.75/75^{1/3} = 4.920$$

The pressure equivalency, uncorrected for the booster weight is

$$E_P^* = (\lambda_{BP}/\lambda_{TNT})^3 = (4.920/10.9)^3 = .0920, \text{ or } 9.20\%$$

A correction is now made to include the weight of the booster

$$W_{TOT} = W_{B.P.} + (1/E_P^*) W_{C4} \quad (1.25)$$

$$= 75 + (1/.0920)(.5)(1.25) = 81.80$$

where the booster weight is multiplied by 1.25 to obtain the equivalent TNT weight of the C4 booster

The corrected scaled distance becomes

$$\lambda_{TOT} = R/W_{TOT}^{1/3} = 20.75/81.8^{1/3} = 4.780$$

The pressure equivalency corrected for inclusion of the booster weight is

$$E_P = (\lambda_{TOT}/\lambda_{TNT})^3 = (4.780/10.9)^3 = .0843 = 8.43\%$$

This procedure is repeated until no significant change occurs in the computed value of the equivalency. For this problem, the final pressure equivalency is 8.43%.

Impulse Equivalency

A scaled impulse is first computed based on the charge weight.

$$I_{SB}/W_{BP}^{1/3} = 18.5/75^{1/3} = 4.387$$

The corresponding scaled distance $\lambda_{BP} = 4.920$

The point representing these values is located on Figure B1. To obtain the TNT impulse at equal radial distance and equal impulse, a 45° line is constructed through this point to the TNT impulse curve. The TNT scaled impulse value at the point of intersection of the two lines is $I_{TNT}/W_{TNT}^{1/3} = 8.1$

The impulse equivalency is then

$$E_I^* = (I_{SB}/W_{BP}^{1/3}) / (I_{TNT}/W_{TNT}^{1/3})^3 \\ = (4.387/8.1)^3 = .1589 = 15.89\%$$

A correction is now made to account for the booster weight

$$W_{TOT} = W_{BP} + (1/E_I^*) W_{C4} (1.25) = 75 + \frac{1}{.1589} (.5)(1.25) = 78.93$$

The new scaled distance and scaled impulse, based on the corrected weight is

$$\lambda_{TOT} = R/W_{TOT}^{1/3} = 20.75/78.93^{1/3} = 4.837$$

$$I_{SB}/W_{TOT}^{1/3} = 18.5/78.93^{1/3} = 4.313$$

The intersection of the 45° line drawn from the corrected point to the impulse curve gives a TNT scaled impulse value of 8.1. The corrected impulse equivalency is

$$\begin{aligned} E_I &= (I_{SB}/W_{TOT}^{1/3}) / (I_{TNT}/W_{TNT}^{1/3})^3 \\ &= (4.313/8.1)^3 = .1509 = 15.09\% \end{aligned}$$

Iteration of this process brings a final TNT impulse equivalency of 14.97%.

APPENDIX C

COMPUTED VALUES OF PRESSURE AND IMPULSE EQUIVALENCIES

APPENDIX C

Computed Values of Pressure and Impulse Equivalencies

CONTENTS

C.1	General	C-1
C.2	Nomenclature	C-1

TABLES

C.1	Summary of Experimental Results	C-2
	Booster Series Tests (BO-)	C-2
	Unconfined Tests (UNC-)	C-5
	Confined Tests (CON-)	C-6
	Squib Tests (SQ-)	C-7

FIGURES

C.1 - C.22	Pressure and Impulse Equivalency	C-8
C.1 - C.12	Booster Series Tests (BO-)	C-8
C.13 - C.15	Unconfined Tests (UNC-)	C-20
C.16 - C.20	Confined Tests (CON-)	C-23
C.21 - C.22	Squib Tests (SQ-)	C-28

C. GENERAL

The computed pressure and impulse equivalencies for the tests described in Volume I are given in tabular and graphical form. The pressure and scaled impulse shown in the tables are based on the curve fitted to the data points given in Appendix A. The mathematical method for computing the equivalencies is described in Appendix B. The scaled quantities, i.e. impulse and distance, are based on the total charge weight which includes a correction for the booster weight.

C.2 NOMENCLATURE

In this appendix, the following table headings are defined as;

R	gauge distance, ft
P	peak overpressure based on curve fit, psig
$I/W^{1/3}$	scaled impulse, where I is the positive impulse based on curve fit, and W is the total weight of explosive corrected to include booster weight, psi-msec/lb ^{1/3}
ZP	scaled distance, λ_P , is used in pressure equivalency calculations, ft/lb ^{1/3}
ZI	scaled distance, λ_I , used in impulse equivalency calculations, ft/lb ^{1/3}
EP	TNT Pressure Equivalency, percent
EI	TNT Impulse Equivalency, percent

SUMMARY OF EXPERIMENTAL RESULTS BLACK POWDER

TEST TYPE	R	P	I/W	ZP	ZI	EP	EI
(FT)	(PSIG)	(PSI-MS/LB)	(FT/LB)	(FT/LB)	(FT/LB)	(%)	(%)
25 LB. BLACK POWDER, .25 LB. 120 DEG. CONE C4 BOOSTER BO 5,6							
6.00	30.32	8.51	1.85	1.98	3.28	11.22	
8.98	15.30	5.77	2.84	2.97	4.66	11.31	
12.79	8.62	4.10	4.11	4.23	5.90	11.40	
17.75	5.18	2.99	5.74	5.87	6.74	11.47	
22.63	3.61	2.37	7.34	7.48	7.09	11.53	
46.71	1.31	1.18	15.14	15.45	7.04	11.70	
25 LB. BLACK POWDER, .50 LB. 120 DEG. CONE C4 BOOSTER BO 8,9							
6.00	43.35	13.23	1.79	1.98	4.78	21.90	
8.98	21.29	8.28	2.77	2.95	6.93	19.43	
12.79	11.68	5.61	4.03	4.19	8.97	18.12	
17.75	6.82	3.99	5.65	5.81	10.42	17.49	
22.63	4.64	3.13	7.24	7.40	11.01	17.36	
46.71	1.55	1.61	14.81	15.33	9.74	18.64	
25 LB. BLACK POWDER, .50 LB. CYLINDRICAL BOOSTER BO 13,12							
6.00	52.73	14.34	1.85	1.99	6.83	24.90	
8.98	23.04	8.94	2.81	2.96	7.99	21.98	
12.79	11.77	6.00	4.04	4.21	9.10	20.16	
17.75	6.61	4.19	5.63	5.83	9.73	18.97	
22.63	4.43	3.24	7.18	7.42	9.86	18.35	
46.71	1.55	1.56	14.80	15.30	9.66	17.71	
27 LB. BLACK POWDER, .024 LB. TETRYL CYLINDRICAL BOOSTER, BO 14,15 S.P.							
4.00	17.49	7.70	1.24	1.32	.47	5.30	
6.98	9.19	4.45	2.25	2.31	1.08	5.27	
10.79	5.37	2.90	3.52	3.57	1.65	5.24	
15.75	3.28	2.00	5.16	5.21	2.04	5.21	
20.63	2.28	1.53	6.76	6.83	2.16	5.19	
44.71	.75	.71	14.60	14.80	1.72	5.14	

SUMMARY OF EXPERIMENTAL RESULTS BLACK POWDER

TEST TYPE	R	P	I/W	ZP	ZI	EP	EI
(FT)	(PSIG)	(PSI-MS/LB)	(FT/LB)	(FT/LB)	(FT/LB)	(%)	(%)
75 LB. BLACK POWDER, .50 LB. C4 CYLINDRICAL BOOSTER, BO 16,18							
9.00	35.10	10.47	2.03	2.10	5.34	16.75	
15.79	13.24	5.81	3.62	3.68	7.84	15.75	
20.75	8.41	4.44	4.78	4.84	8.91	15.66	
25.63	5.98	3.62	5.91	5.97	9.48	15.76	
49.71	2.16	2.00	11.46	11.60	9.33	17.06	
11.98	21.23	7.72	2.73	2.79	6.58	16.10	
75 LB. BLACK POWDER, .50 LB. C4 CYLINDRICAL BOOSTER, BO 17,19 S.P.							
9.00	44.46	12.15	2.06	2.11	7.55	21.11	
15.79	14.47	6.36	3.64	3.69	9.04	18.11	
20.75	8.84	4.74	4.79	4.84	9.72	17.37	
25.63	6.18	3.81	5.92	5.93	10.09	17.06	
49.71	2.30	2.03	11.50	11.61	10.84	17.51	
75 LB. BLACK POWDER, 1.0 LB. C4 CYLINDRICAL BOOSTER, BO 20,21							
9.00	64.45	17.09	2.04	2.10	11.93	35.31	
15.79	20.34	8.17	3.61	3.67	14.34	26.29	
20.75	12.01	5.92	4.76	4.81	15.35	24.08	
25.63	8.12	4.69	5.88	5.94	15.66	23.07	
49.71	2.59	2.47	11.34	11.52	13.33	23.33	
75 LB. BLACK POWDER, 1.5 LB. C4 CYLINDRICAL BOOSTER, BO 30,31 S.P.							
12.00	36.00	12.12	2.74	2.80	13.43	32.03	
14.98	24.22	9.18	3.44	3.49	15.68	29.09	
18.79	16.15	7.04	4.33	4.37	17.84	27.17	
23.75	10.63	5.47	5.48	5.52	19.48	26.16	
28.63	7.61	4.54	6.61	6.65	20.02	25.99	
52.71	2.56	2.71	12.09	12.27	15.74	29.45	

SUMMARY OF EXPERIMENTAL RESULTS BLACK POWDER

TEST TYPE	R	P	I/W	ZP	ZI	EP	EI
	(FT)	(PSIG)	(PSI-MS/LB) ^{1/3}	(FT/LB) ^{1/3}	(FT/LB) ^{1/3}	(%)	(%)
25 LB. BLACK POWDER, 1.0 LB. C4 CYLINDRICAL BOOSTER, BO 32.33 S.P.							
	6.00	78.69	19.86	1.81	1.97	10.77	40.42
	8.98	38.06	12.31	2.80	2.94	15.45	35.28
	12.79	20.13	8.25	4.06	4.17	20.16	32.29
	17.75	11.15	5.79	5.70	5.78	23.65	30.55
	22.63	7.20	4.50	7.28	7.36	24.41	29.82
	46.71	1.95	2.24	14.56	15.19	15.39	30.22
25 LB. BLACK POWDER, 0.54 LB. PBX CYLINDRICAL BOOSTER, BO 36.37 S.P.							
	6.00	63.25	17.38	1.88	2.00	9.10	33.64
	8.98	29.86	10.61	2.88	2.98	12.19	28.74
	12.79	15.61	7.03	4.14	4.23	14.91	25.88
	17.75	8.63	4.89	5.77	5.86	16.38	24.15
	22.63	5.59	3.78	7.36	7.46	16.22	23.36
	46.71	1.57	1.85	14.74	15.40	9.80	23.18
150 LB. BLACK POWDER, 1.5 LB. C4 CYLINDRICAL BOOSTER BO 40, S.P.							
	12.00	42.86	13.62	2.16	2.22	8.24	27.21
	14.98	29.38	10.13	2.71	2.77	9.99	24.04
	18.79	19.98	7.73	3.42	3.47	11.90	22.28
	23.75	13.41	6.06	4.34	4.39	13.78	21.74
	28.63	9.76	5.11	5.25	5.29	14.96	22.20
	52.71	3.45	3.44	9.66	9.79	14.83	30.28
150 LB. BLACK POWDER, 3.0 LB. C4 CYLINDRICAL BOOSTER BO 41,42 S.P.							
	12.00	59.93	18.47	2.13	2.22	12.20	42.97
	14.98	40.60	13.29	2.68	2.76	14.71	36.05
	18.79	27.07	9.73	3.38	3.45	17.40	31.26
	23.75	17.67	7.24	4.30	4.35	19.89	28.09
	28.63	12.51	5.82	5.19	5.23	21.24	26.57
	52.71	3.90	3.22	9.50	9.63	17.97	26.75

SUMMARY OF EXPERIMENTAL RESULTS BLACK POWDER

TEST TYPE	R (FT)	P (PSIG)	1/3		ZI (FT/LB)	EP (%)	EI (%)
			I/W (PSI-MS/LB)	ZP (FT/LB)			
27 LB. BLACK POWDER, .024 LB. CYLINDRICAL TETRYL BOOSTER, UNC 1,2 STAND OFF							
	4.00	4.61	1.04	.19	1.16	.00	.21
	6.98	2.30	.62	.67	2.03	.00	.22
	10.79	1.38	.41	1.48	3.15	.01	.22
	15.75	.91	.29	2.76	4.61	.02	.23
	20.63	.68	.22	4.24	6.06	.03	.24
	44.71	.32	.11	12.44	13.20	.15	.25
64 LB. BLACK POWDER, .024 LB. CYLINDRICAL TETRYL BOOSTER, UNC 4 STAND OFF							
	4.00	3.87	.50	.05	.76	.00	.04
	6.98	2.10	.30	.30	1.35	.00	.04
	10.79	1.30	.20	.85	2.10	.00	.04
	15.25	.87	.15	1.75	2.98	.00	.04
	20.63	.65	.11	2.76	4.04	.01	.04
	44.71	.29	.05	8.63	8.71	.04	.04
27 LB. BLACK POWDER, .024 LB. CYLINDRICAL TETRYL BOOSTER, UNC 5							
	4.00	14.23	6.64	1.21	1.32	.32	4.23
	6.98	6.47	3.51	2.19	2.30	.55	3.66
	10.79	3.92	2.32	3.46	3.56	.87	3.73
	15.75	2.75	1.73	5.12	5.21	1.39	4.18
	44.71	1.55	1.03	14.85	14.84	9.71	9.00
140 LB. BLACK POWDER, .024 LB. CYLINDRICAL TETRYL BOOSTER UNC 6							
	7.50	16.10	11.01	1.43	1.44	.64	10.37
	10.48	11.36	7.99	2.00	2.02	1.06	10.48
	14.29	8.81	5.98	2.74	2.75	1.81	10.69
	19.25	7.34	4.56	3.70	3.70	3.30	11.00
	24.13	6.66	3.72	4.64	4.64	5.53	11.31
	48.21	6.14	2.05	9.28	9.28	38.43	12.73

SUMMARY OF EXPERIMENTAL RESULTS BLACK POWDER

TEST TYPE	R	P	1/3			EI
			I/W	ZP	ZI	
	(FT)	(PSIG)	(PSI-MS/LB) ^{1/3}	(FT/LB) ^{1/3}	(FT/LB) ^{1/3}	(%)
27 LB. JET MILL PRODUCT. .024 LB. CYLINDRICAL TETRYL BOOSTER UNC 9						
	4.00	3.83	6.03	.07	1.32	.00
	6.98	2.28	3.48	.64	2.30	.00
	10.79	1.47	2.26	1.85	3.56	.02
	15.75	.97	1.55	3.32	5.20	.04
	20.63	.72	1.19	4.68	6.81	.05
	44.71	.28	.55	11.20	14.75	.08
8 LB. BLACK POWDER, .024 LB. CYLINDRICAL TETRYL BOOSTER CON 1,2						
	15.59	4.48	3.13	7.72	7.74	12.52
	20.55	3.17	2.44	10.19	10.21	14.70
	25.43	2.39	2.03	12.62	12.64	15.56
	49.51	.91	1.17	24.52	24.62	12.73
	4.00	17.76	11.84	1.87	1.99	1.65
	6.98	10.79	6.71	3.40	3.47	4.77
	10.79	6.86	4.40	5.32	5.36	8.76
	44.71	1.06	1.27	22.16	22.23	13.58
27 LB. BLACK POWDER, .024 LB. CYLINDRICAL TETRYL BOOSTER CON 3,4,5						
	7.50	24.42	9.85	2.48	2.50	6.00
	10.48	14.58	6.94	3.48	3.49	7.99
	14.29	9.17	5.06	4.75	4.75	10.03
	19.25	5.95	3.77	6.40	6.40	11.90
	24.13	4.32	3.03	8.02	8.03	13.09
	48.21	1.69	1.60	16.03	16.04	15.00
64 LB. BLACK POWDER, .024 LB. CYLINDRICAL TETRYL BOOSTER CON 6,7,8						
	7.50	41.09	13.28	1.87	1.87	5.08
	10.48	26.99	9.99	2.61	2.62	8.00
	14.29	17.76	7.67	3.57	3.57	11.45
	19.25	11.58	5.95	4.81	4.81	15.00
	24.13	8.23	4.91	6.03	6.03	17.27
	48.21	2.64	2.72	12.04	12.05	16.68
						20.29
						21.62
						22.93
						24.26
						25.32
						28.87

SUMMARY OF EXPERIMENTAL RESULTS BLACK POWDER

TEST TYPE	R	P	I/W	1/3	ZP	1/3	ZI	1/3	EP	EI
	(FT)	(PSIG)	(PSI-MS/LB)	(FT/LB)	(FT/LB)	(FT/LB)	(FT/LB)	(FT/LB)	(%)	(%)
140 LB. BLACK POWDER, .024 LB. CYLINDRICAL TETRYL BOOSTER CON 9.10										
	8.50	67.06	16.78	1.64		1.64		1.64	6.43	23.70
	15.29	34.15	11.17	2.94		2.94		2.94	15.57	30.50
	20.25	22.67	8.87	3.90		3.90		3.90	20.94	32.61
	25.13	15.92	7.32	4.84		4.84		4.84	24.45	33.52
	49.21	4.29	3.68	9.47		9.47		9.48	21.27	32.01
27 LB. JET MILL PRODUCT, .024LB. CYLINDRICAL TETRYL BOOSTER CON 11.12										
	7.50	10.39	5.61	2.45		2.49		2.49	1.67	8.36
	10.48	6.63	4.21	3.44		3.48		3.48	2.23	8.89
	14.29	4.44	3.23	4.70		4.74		4.74	2.78	9.41
	19.25	3.06	2.50	6.35		6.39		6.39	3.30	9.94
	24.13	2.32	2.06	7.97		8.01		8.01	3.68	10.36
	48.21	1.05	1.14	15.95		16.02		16.02	4.90	11.76
27 LB. BLACK POWDER SQUIB IGNITION SQ 1,2,3										
	7.50	17.75	6.80	2.50		2.50		2.50	3.94	11.26
	10.48	10.93	4.74	3.49		3.49		3.49	5.27	10.70
	14.29	6.98	3.46	4.76		4.76		4.76	6.47	10.52
	19.25	4.53	2.61	6.42		6.42		6.42	7.34	10.63
	24.13	3.27	2.13	8.04		8.04		8.04	7.67	10.90
	48.21	1.20	1.21	16.07		16.07		16.07	6.85	12.97
27 LB. JET MILL PRODUCT, SQUIB IGNITION SQ 4,5										
	7.50	14.57	8.17	2.50		2.50		2.50	2.97	14.89
	10.48	10.03	6.35	3.49		3.49		3.49	4.61	16.69
	14.29	6.99	4.98	4.76		4.76		4.76	6.49	18.25
	19.25	4.87	3.90	6.42		6.42		6.42	8.38	19.59
	24.13	3.67	3.22	8.04		8.04		8.04	9.64	20.48
	48.21	1.46	1.73	16.07		16.07		16.07	10.88	22.26

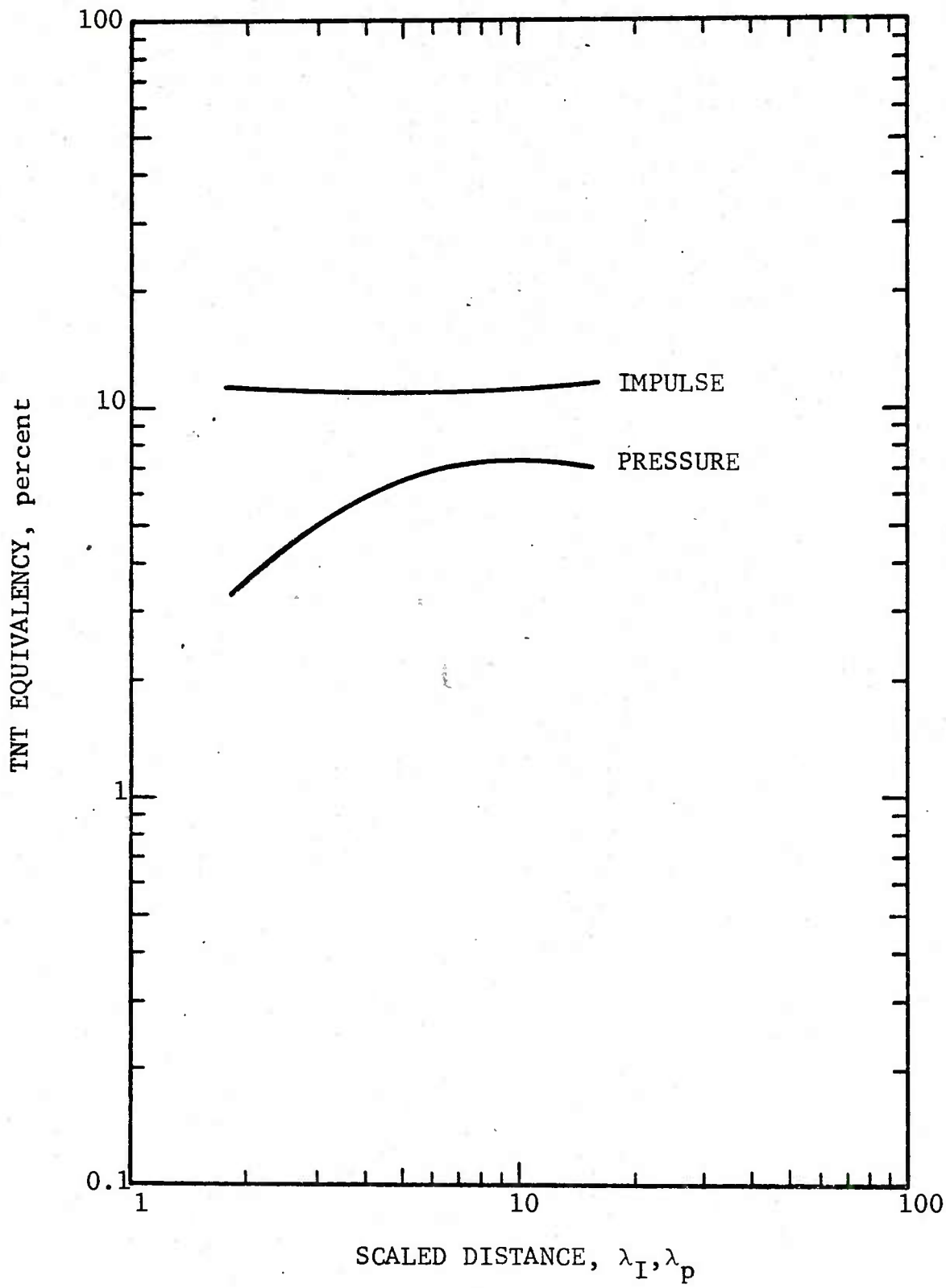

Figure C.1 PRESSURE AND IMPULSE EQUIVALENCY; TESTS BO-5,6
25 lb BLACK POWDER, 0.25 lb C4 BOOSTER

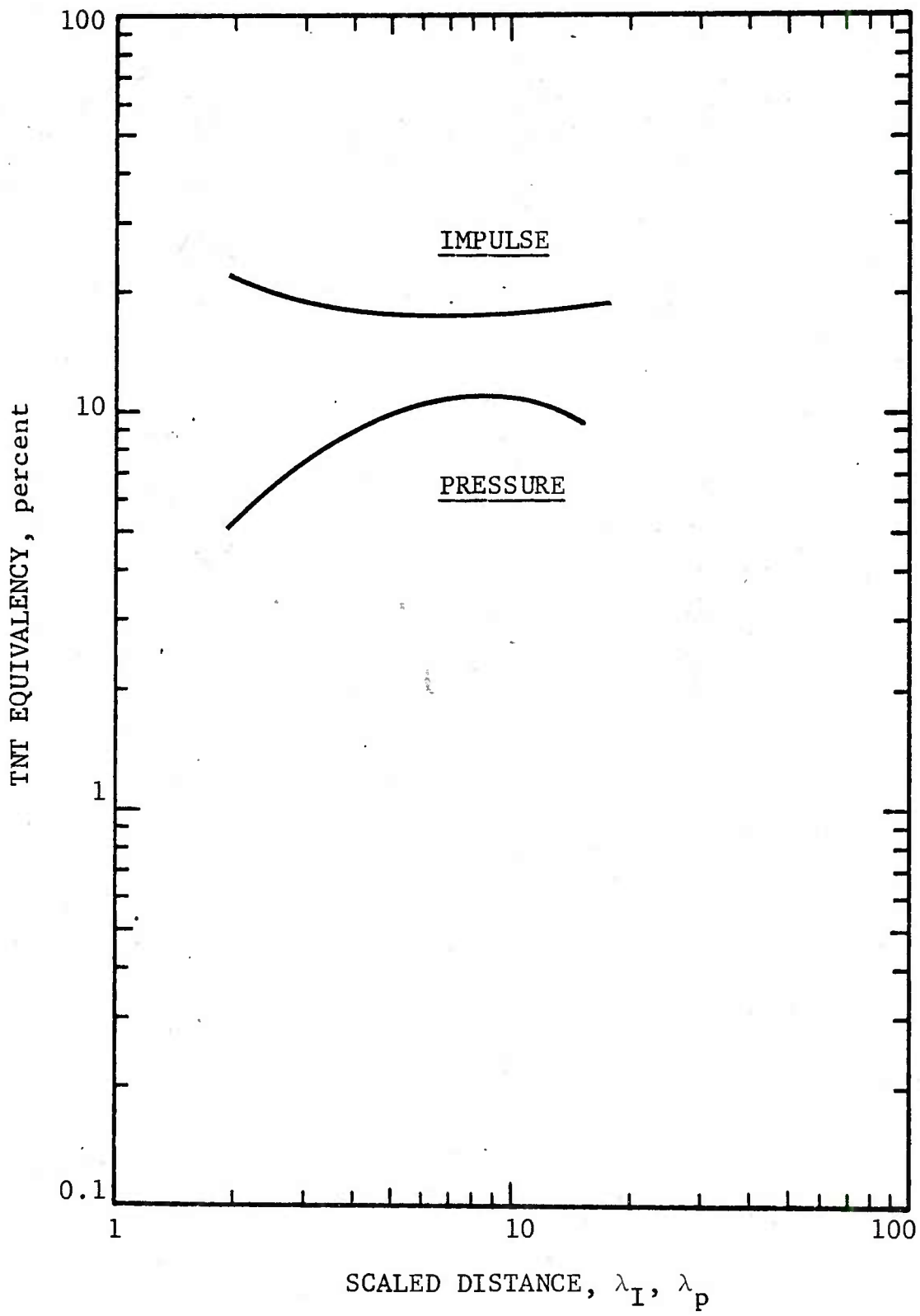

Figure C.2 PRESSURE AND IMPULSE EQUIVALENCY; TESTS BO-8,9
25 lb BLACK POWDER, 0.50 lb C4 BOOSTER

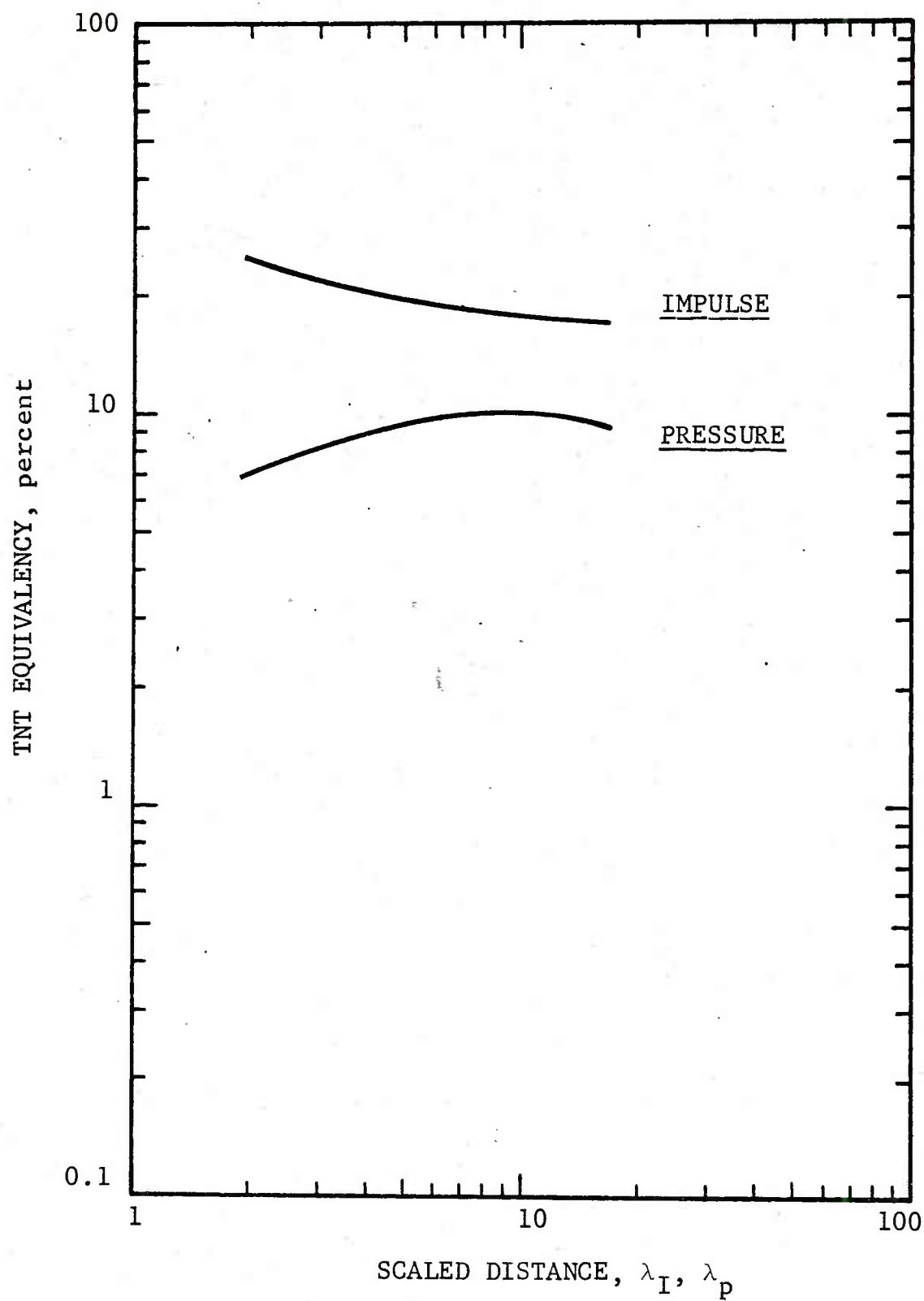

Figure C.3 PRESSURE AND IMPULSE EQUIVALENCY; TESTS BO-12,13
 25 lb BLACK POWDER, 0.50 lb C4 BOOSTER

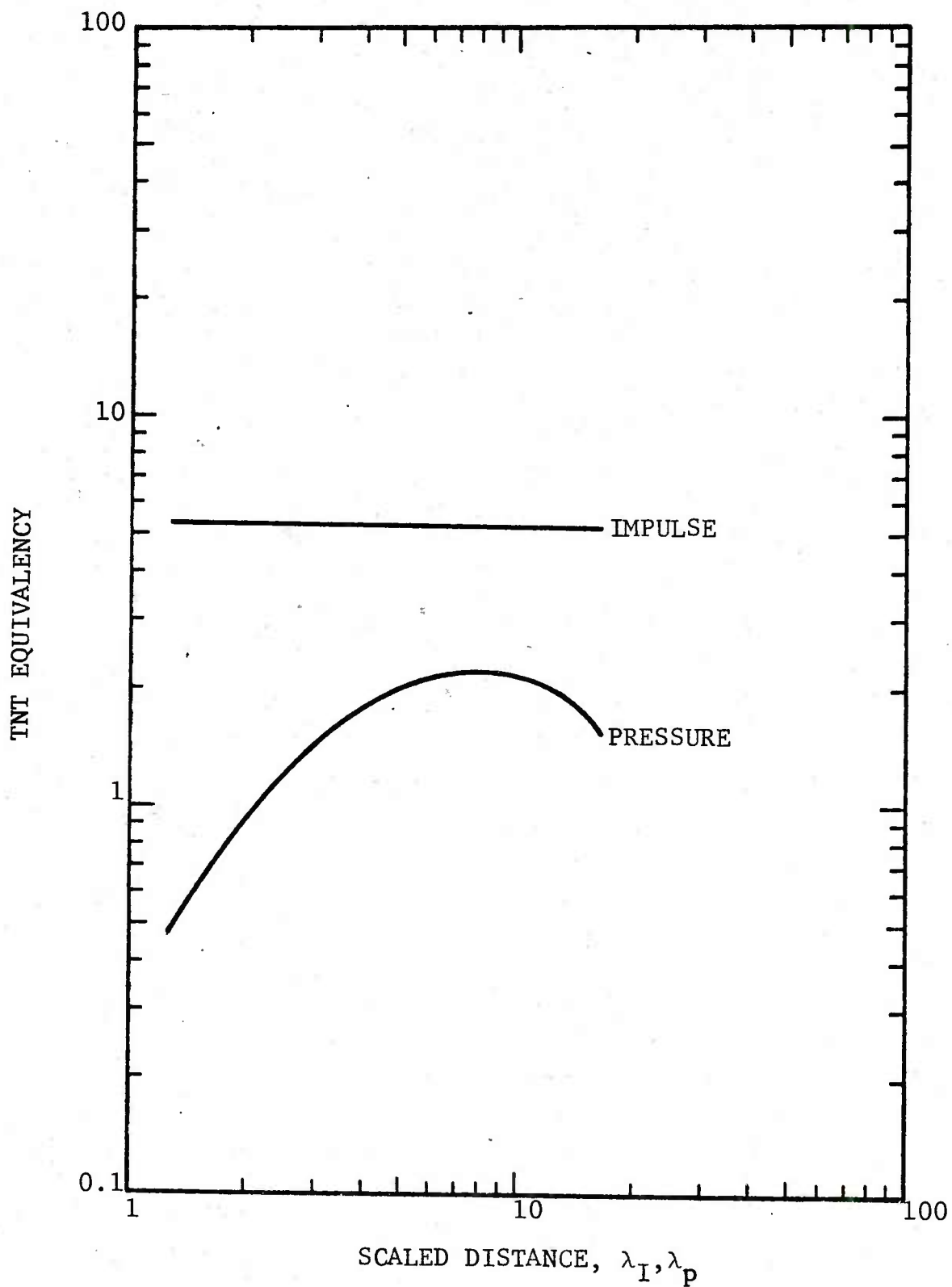

Figure C.4 PRESSURE AND IMPULSE EQUIVALENCY; TESTS BO-14,15
27 lb BLACK POWDER, 0.024 lb TETRYL BOOSTER

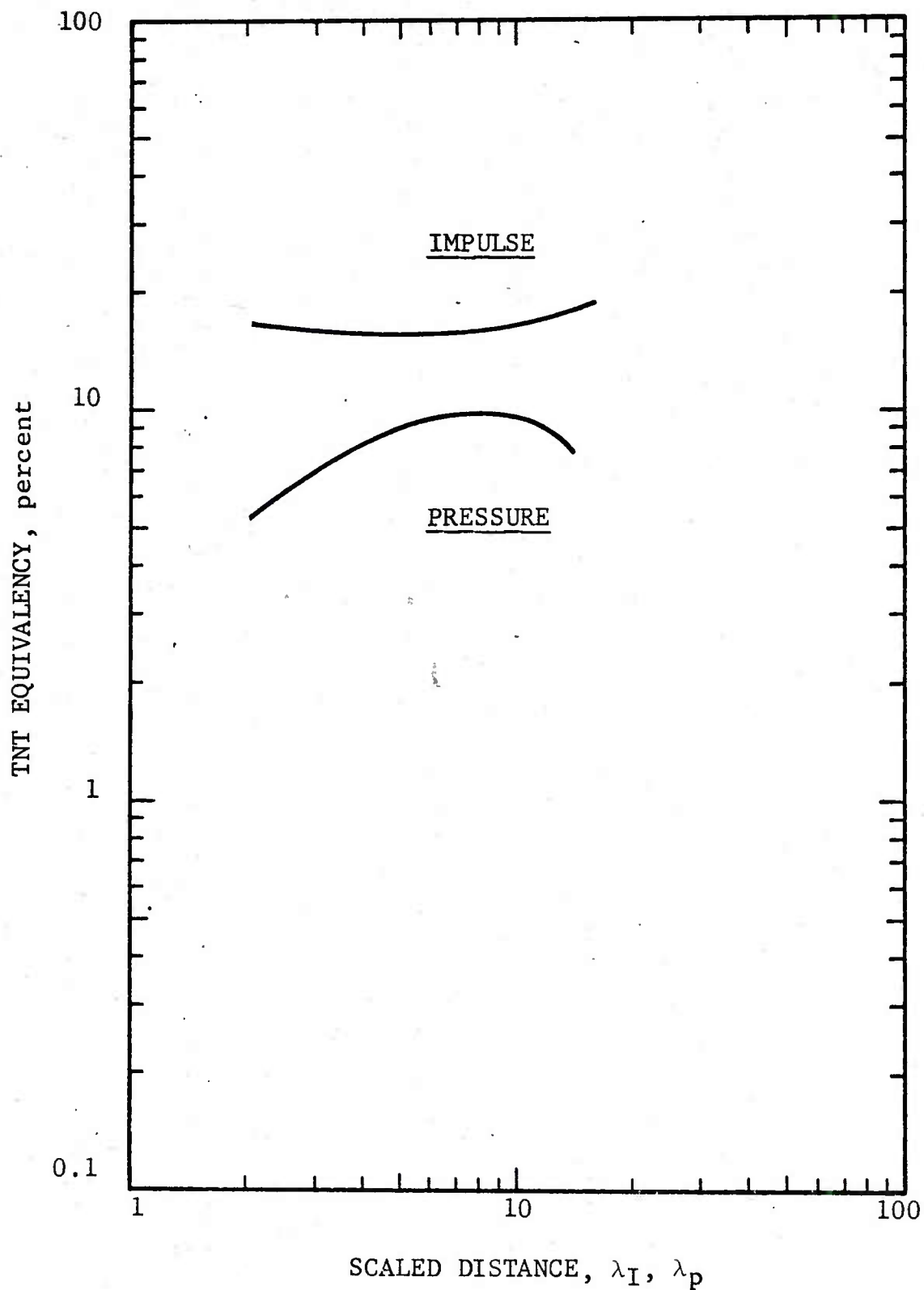

Figure C.5 PRESSURE AND IMPULSE EQUIVALENCY; TESTS BO-16,18
75 lb BLACK POWDER, 0.50 lb C4 BOOSTER

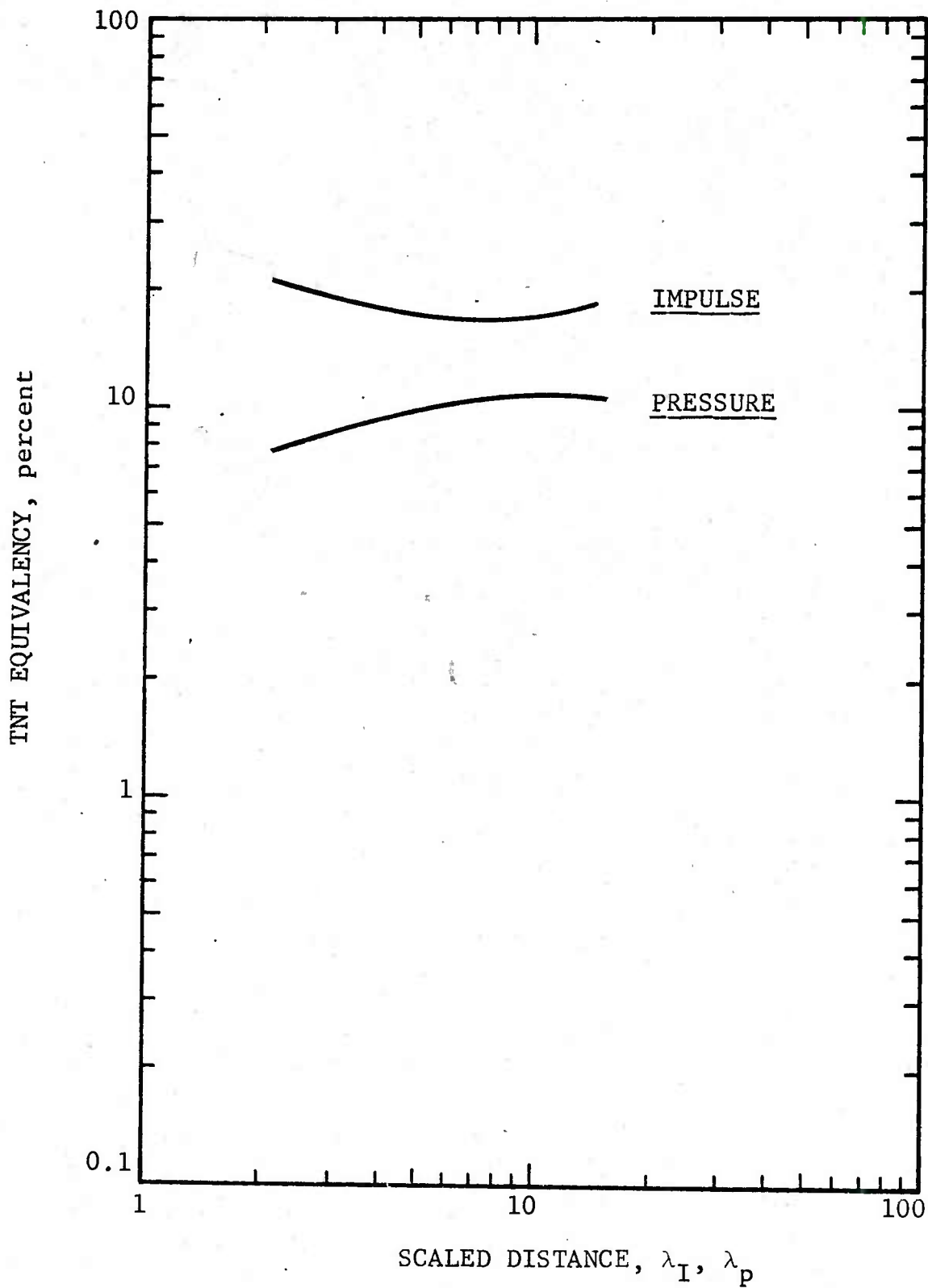

Figure C.6 PRESSURE AND IMPULSE EQUIVALENCY; TESTS BO-17,19
75 lb BLACK POWDER, 0.50 lb C4 BOOSTER

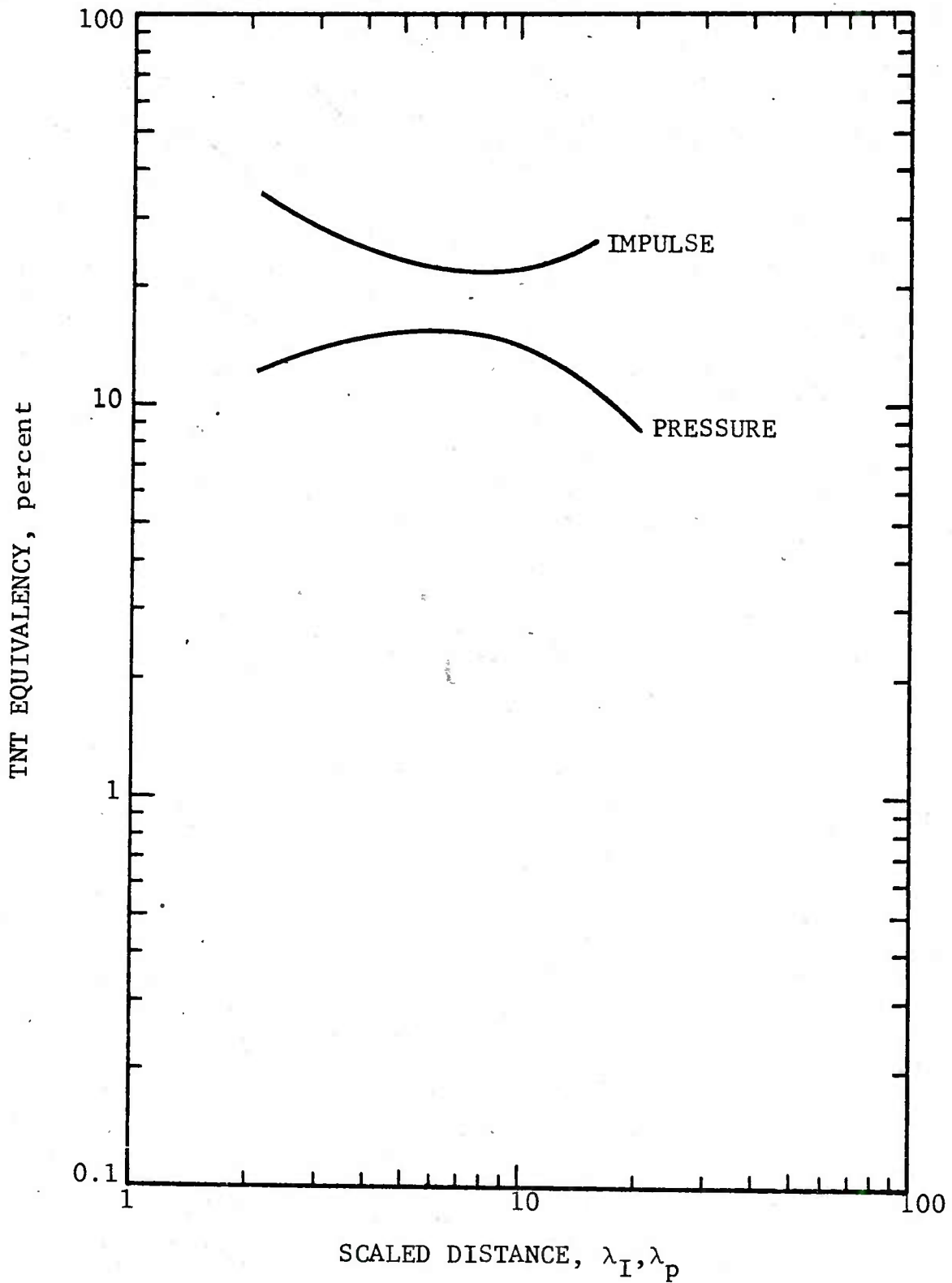

Figure C.7 PRESSURE AND IMPULSE EQUIVALENCY; TESTS BO-20,21
75 lb BLACK POWDER, 1.00 lb C4 BOOSTER

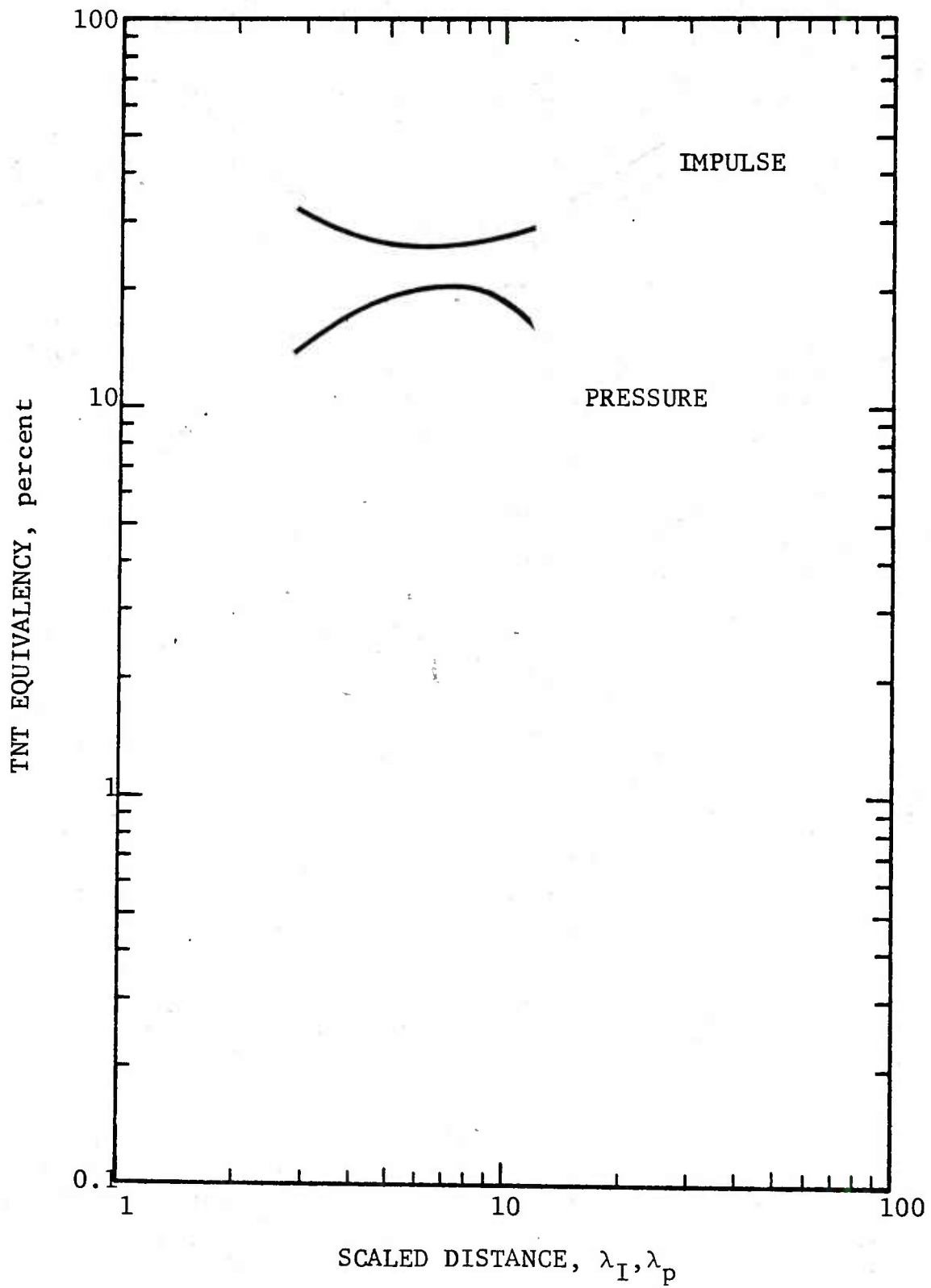

Figure C.8 PRESSURE AND IMPULSE EQUIVALENCY; TESTS BO-30,31
75 lb BLACK POWDER, 1.50 lb C4 BOOSTER

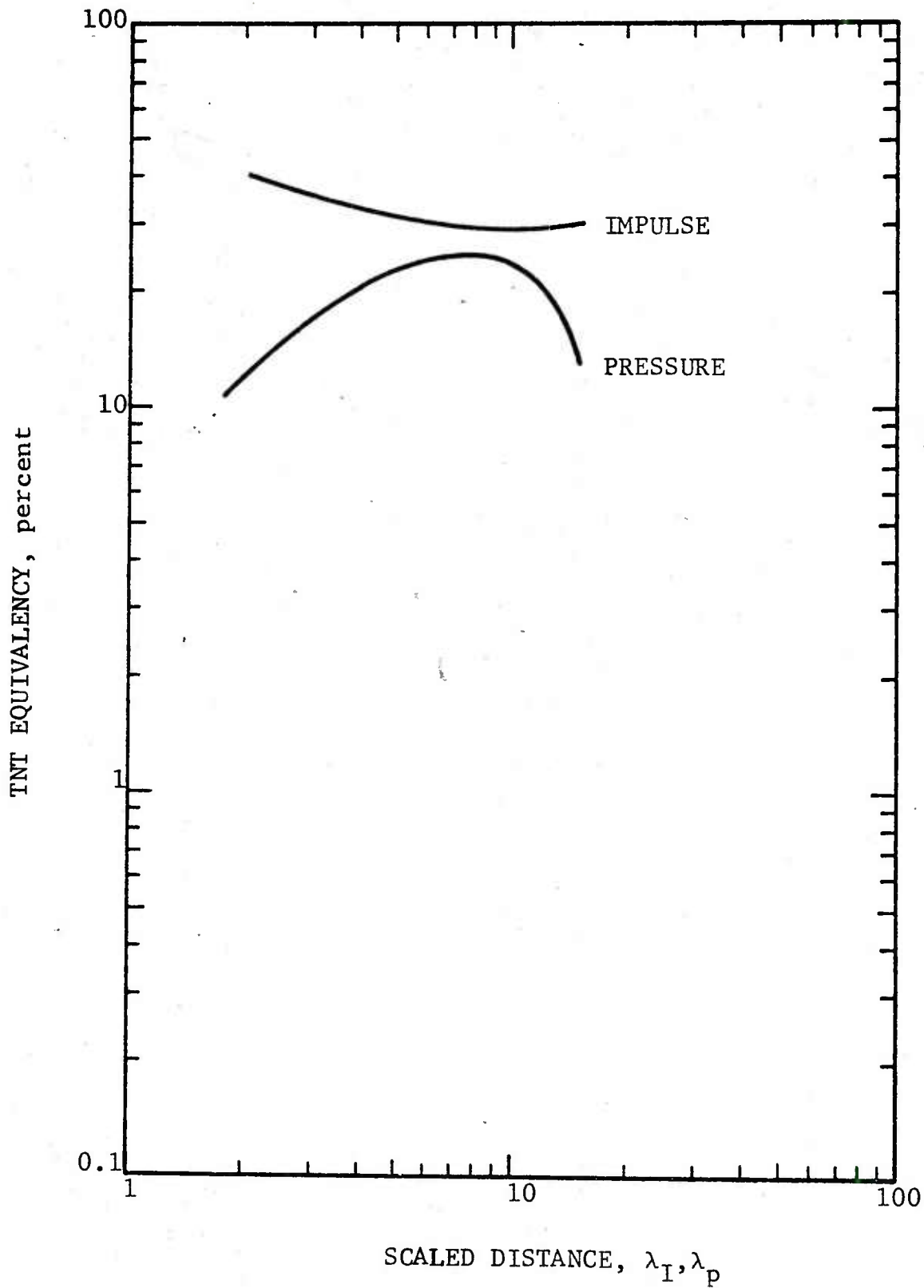

Figure C.9 PRESSURE AND IMPULSE EQUIVALENCY; TEST BO-32,33
25 lb BLACK POWDER, 1.00 lb C4 BOOSTER

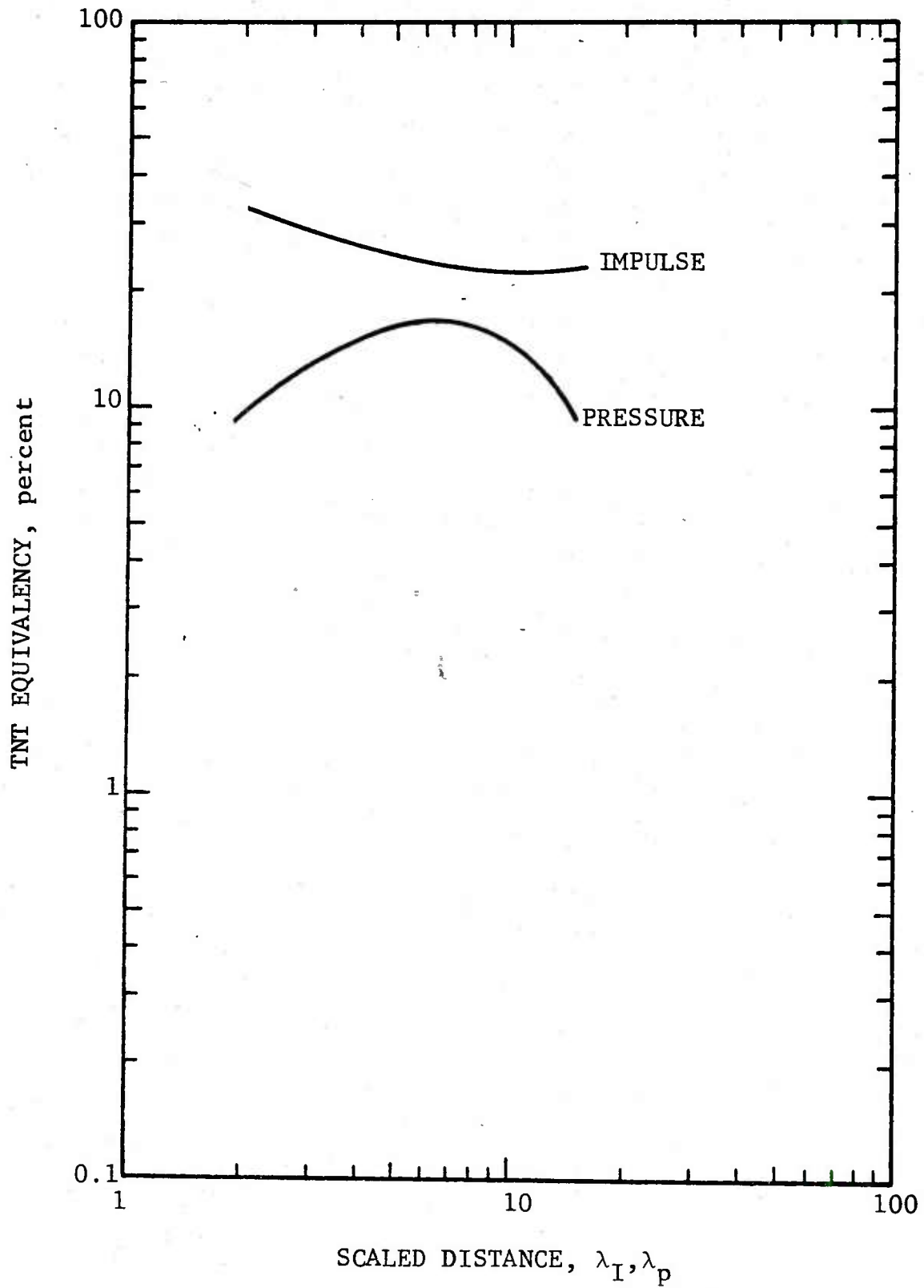

Figure C.10 PRESSURE AND IMPULSE EQUIVALENCY; TESTS BO-36,37
25 lb BLACK POWDER, 0.54 lb PBX BOOSTER

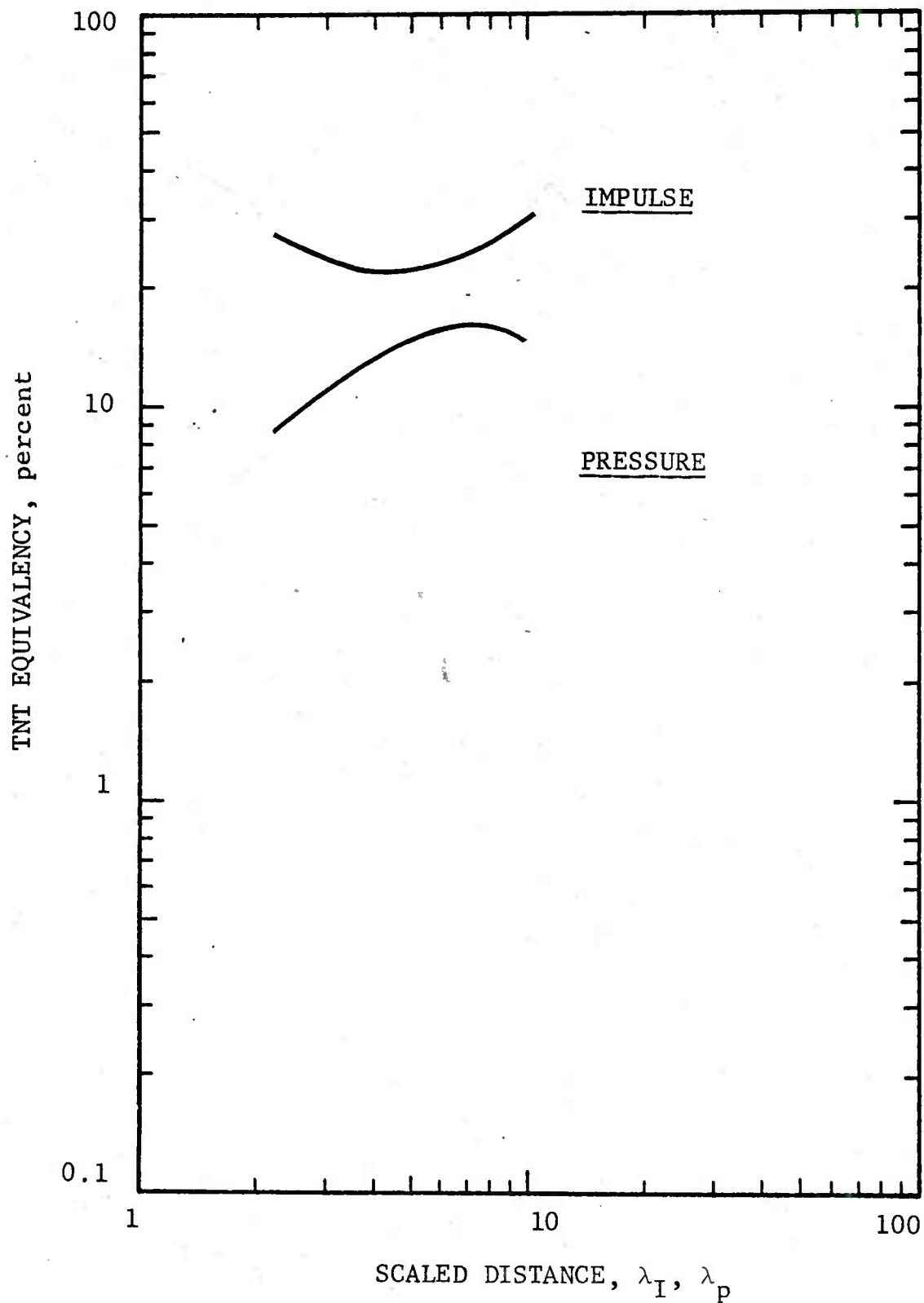

Figure C.11 PRESSURE AND IMPULSE EQUIVALENCY; TEST BO-40
 150 lb BLACK POWDER, 1.50 lb C4 BOOSTER

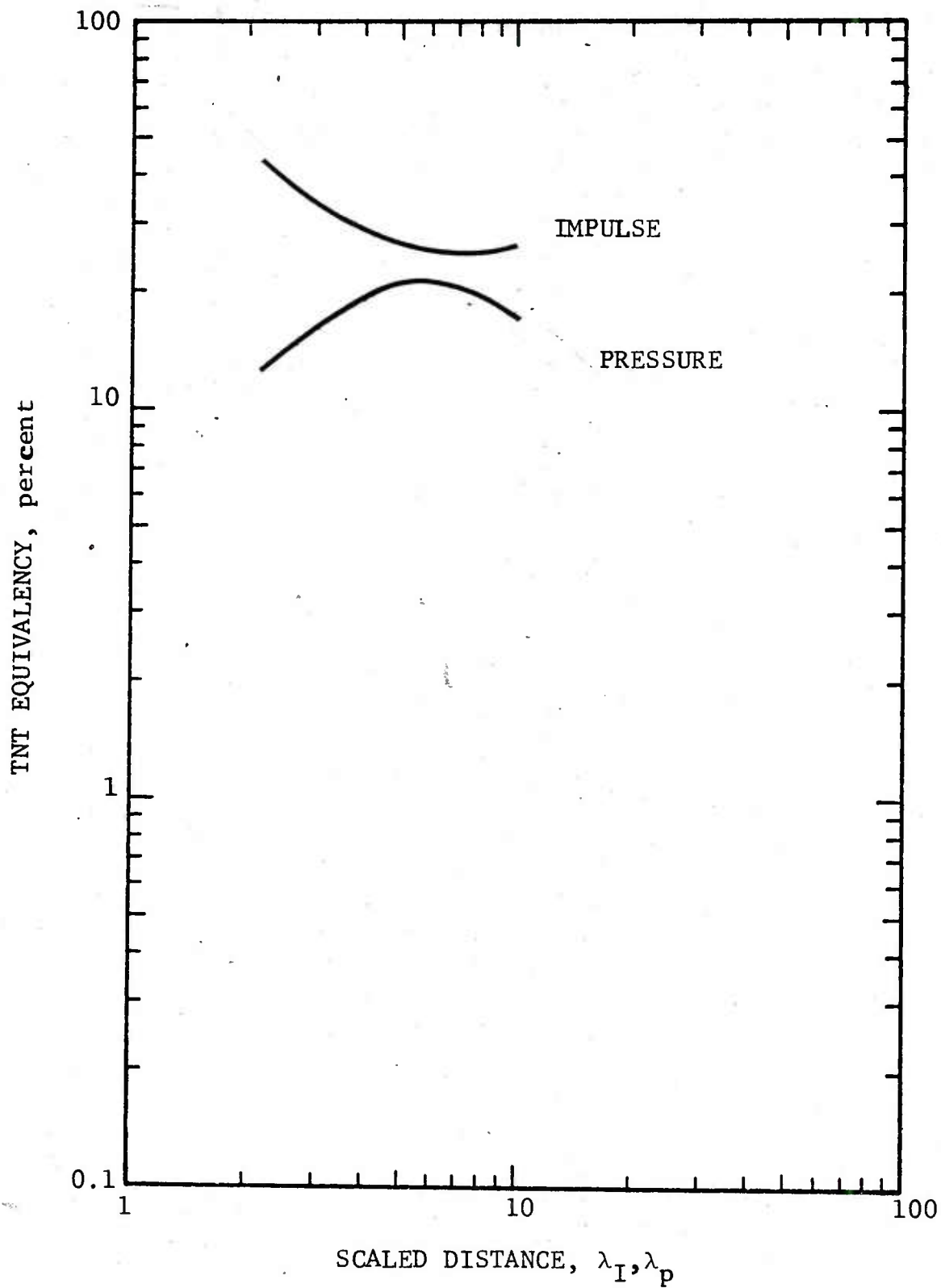

Figure C.12 PRESSURE AND IMPULSE EQUIVALENCY; TESTS BO-41,42
150 lb BLACK POWDER, 3.00 lb C4 BOOSTER

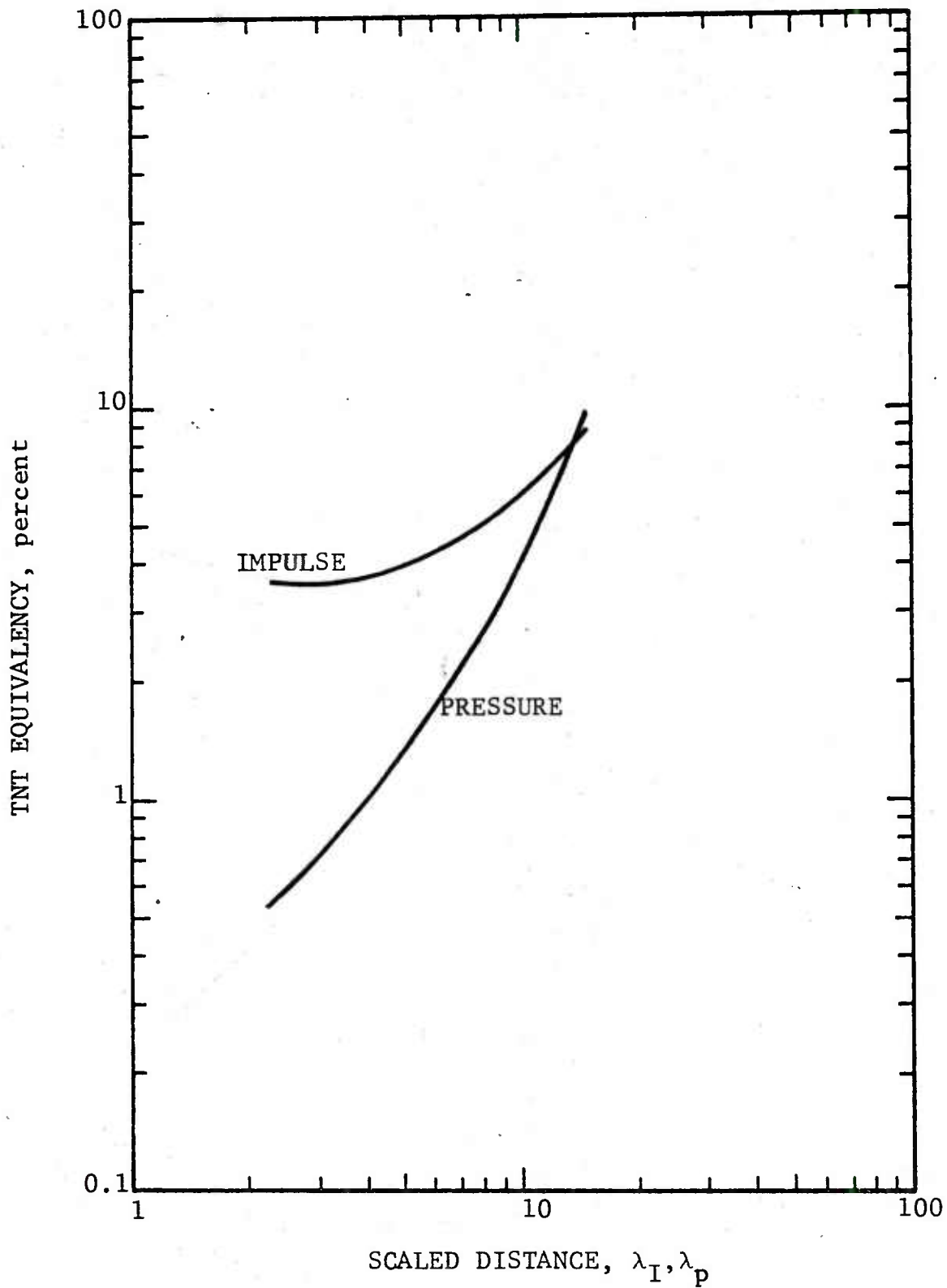

Figure C.13 PRESSURE AND IMPULSE EQUIVALENCY; TEST UNC-5
27 lb BLACK POWDER, 0.024 lb TETRYL BOOSTER

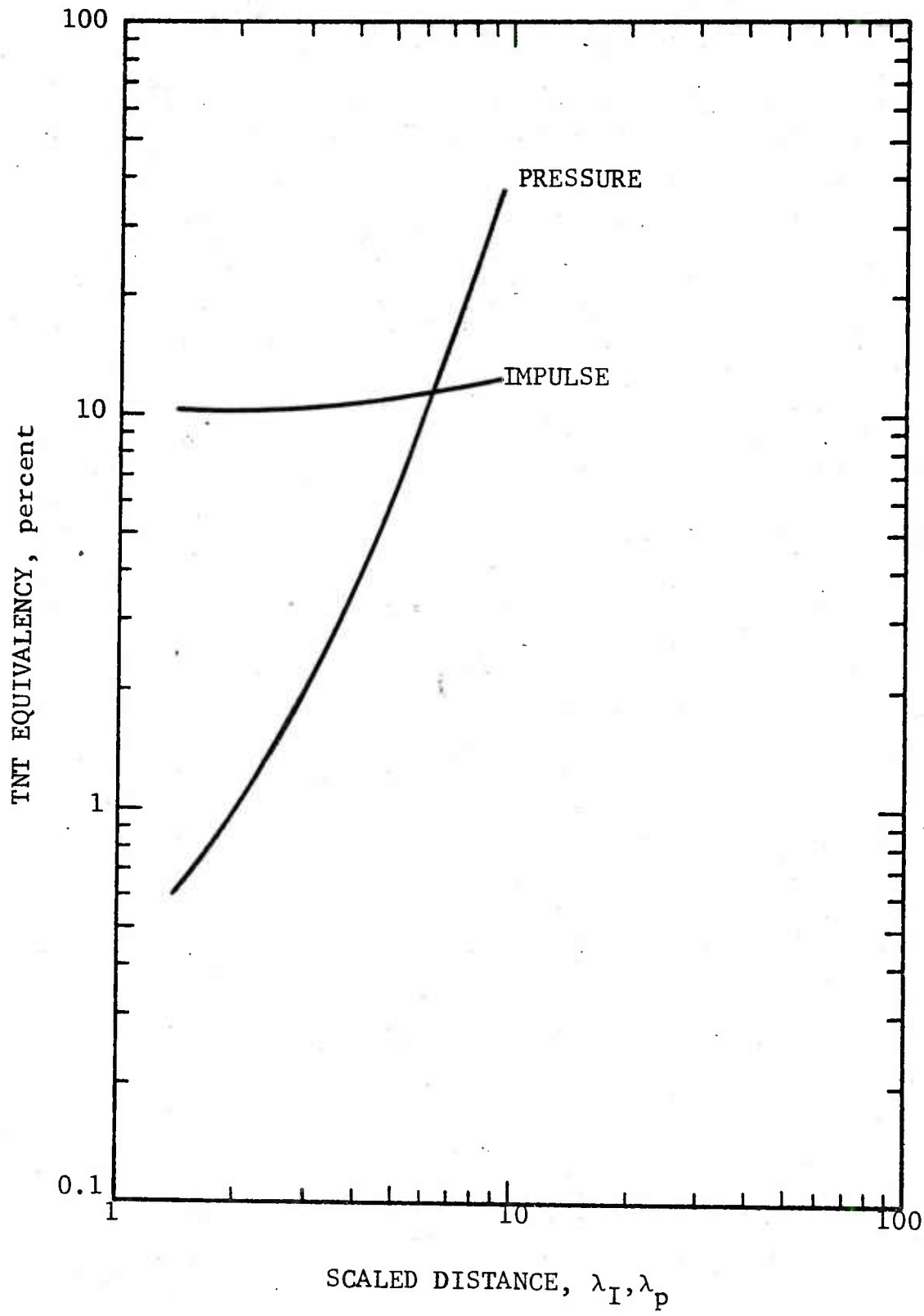

Figure C.14 PRESSURE AND IMPULSE EQUIVALENCY; TEST UNC-6
140 lb BLACK POWDER, 0.024 lb C4 BOOSTER

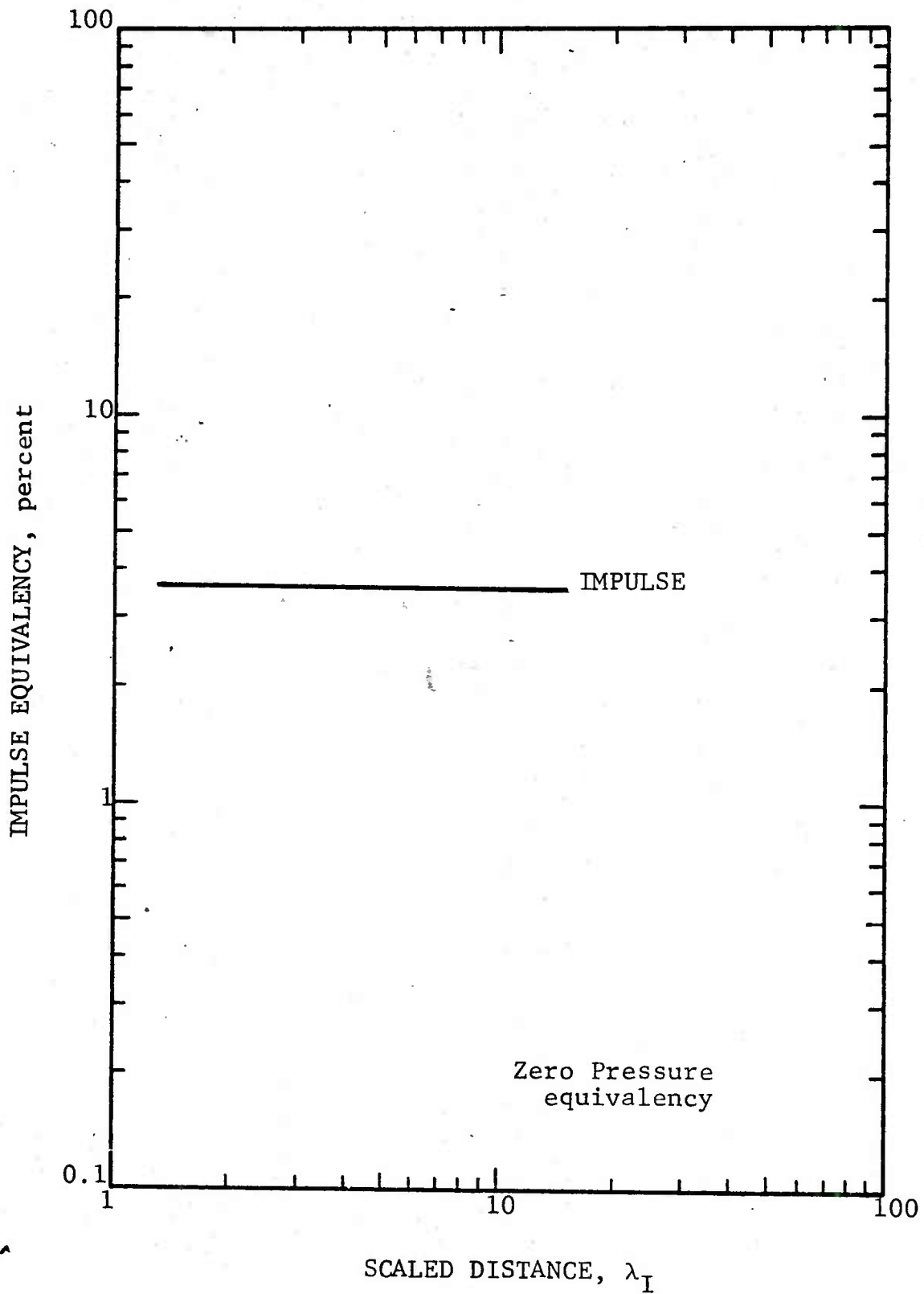

Figure C.15 IMPULSE EQUIVALENCY; TEST UNC-9
 27 lb JET MILLED MATERIAL, 0.024 lb TETRYL BOOSTER

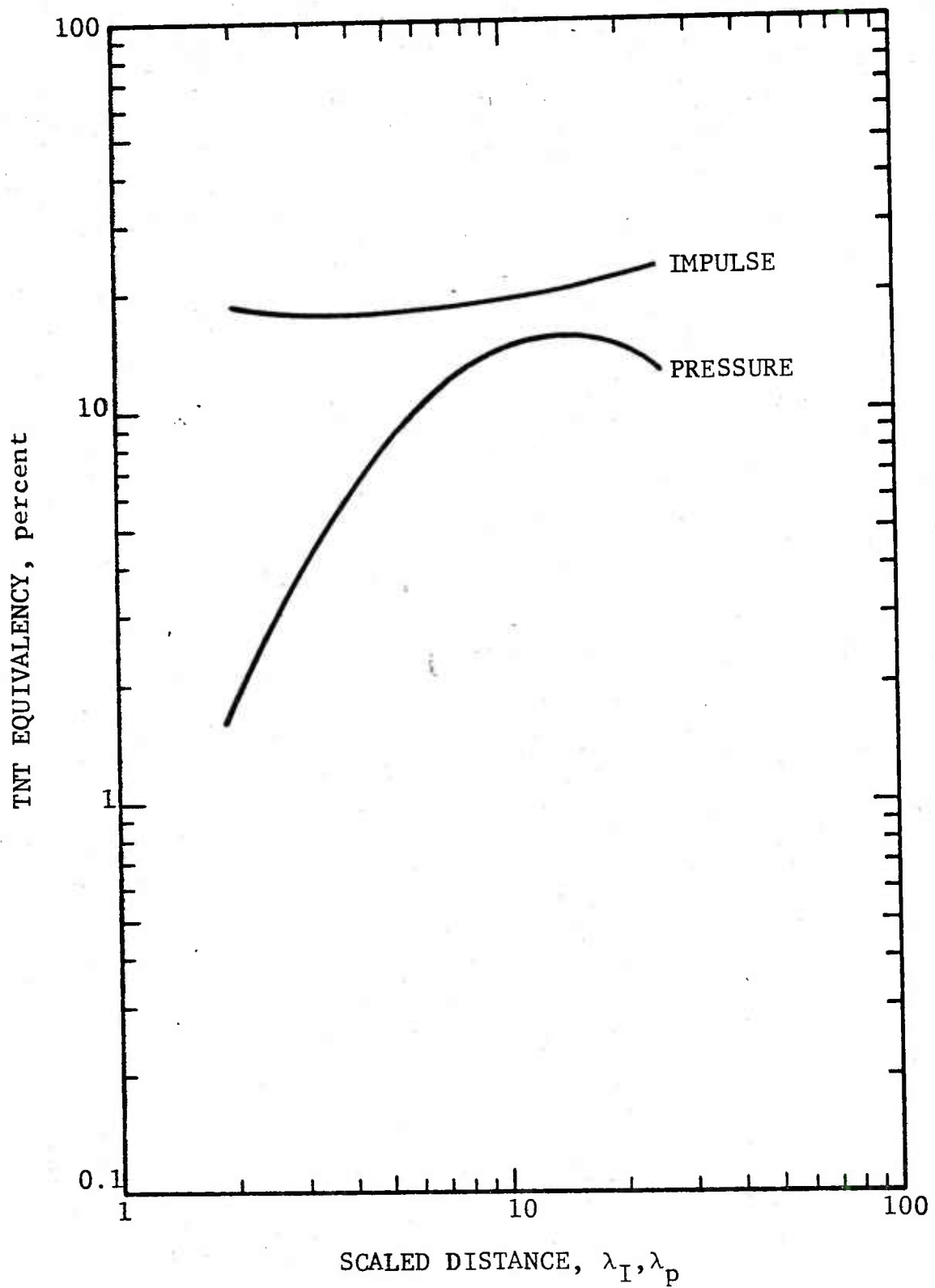

Figure C.16 PRESSURE AND IMPULSE EQUIVALENCY; TESTS CON-1,2
8 lb BLACK POWDER, 0.024 lb TETRYL BOOSTER

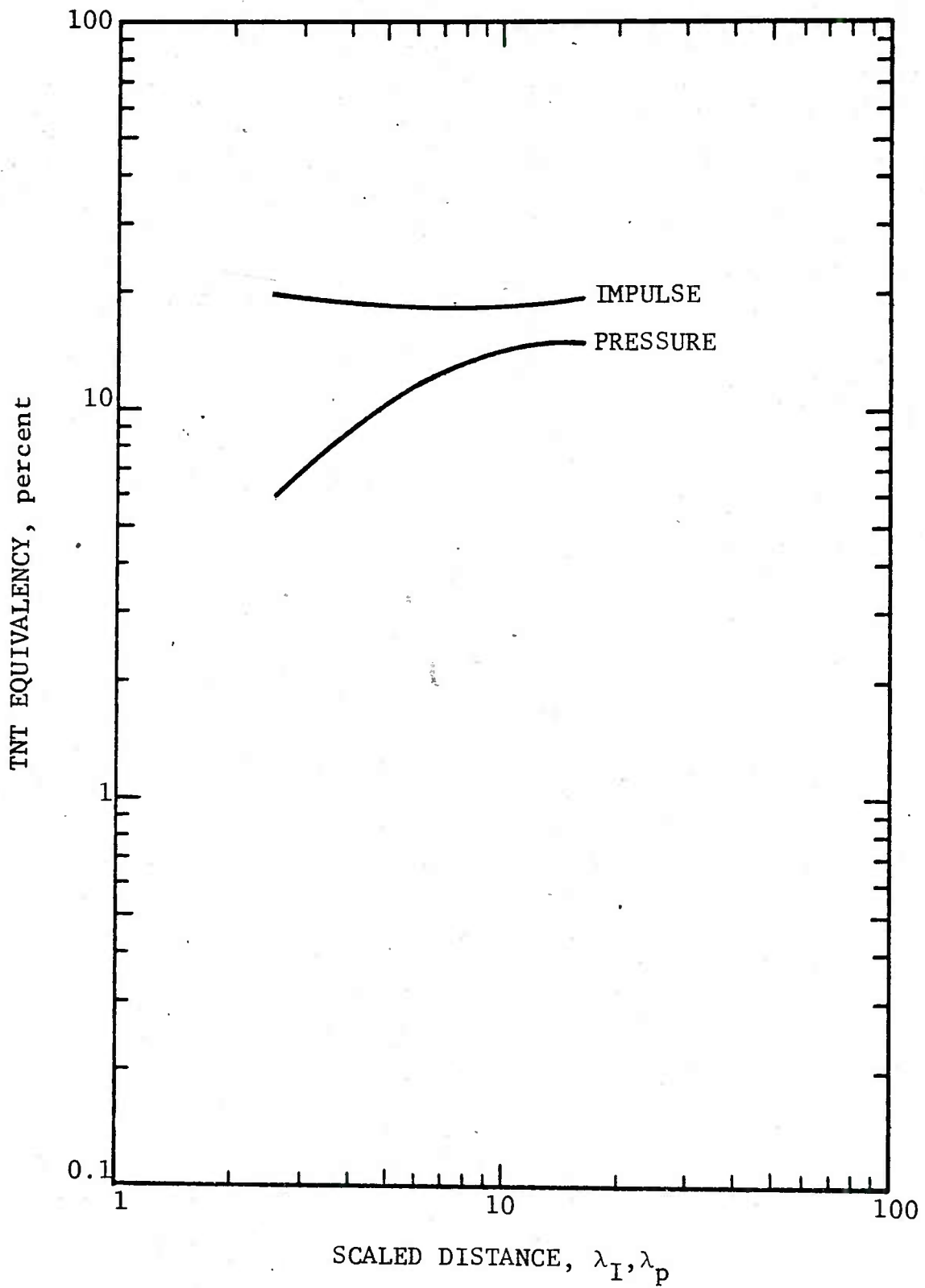

Figure C.17 PRESSURE AND IMPULSE EQUIVALENCY; TESTS CON-3,4,5
27 1b BLACK POWDER, 0 024 1b TETRYL BOOSTER

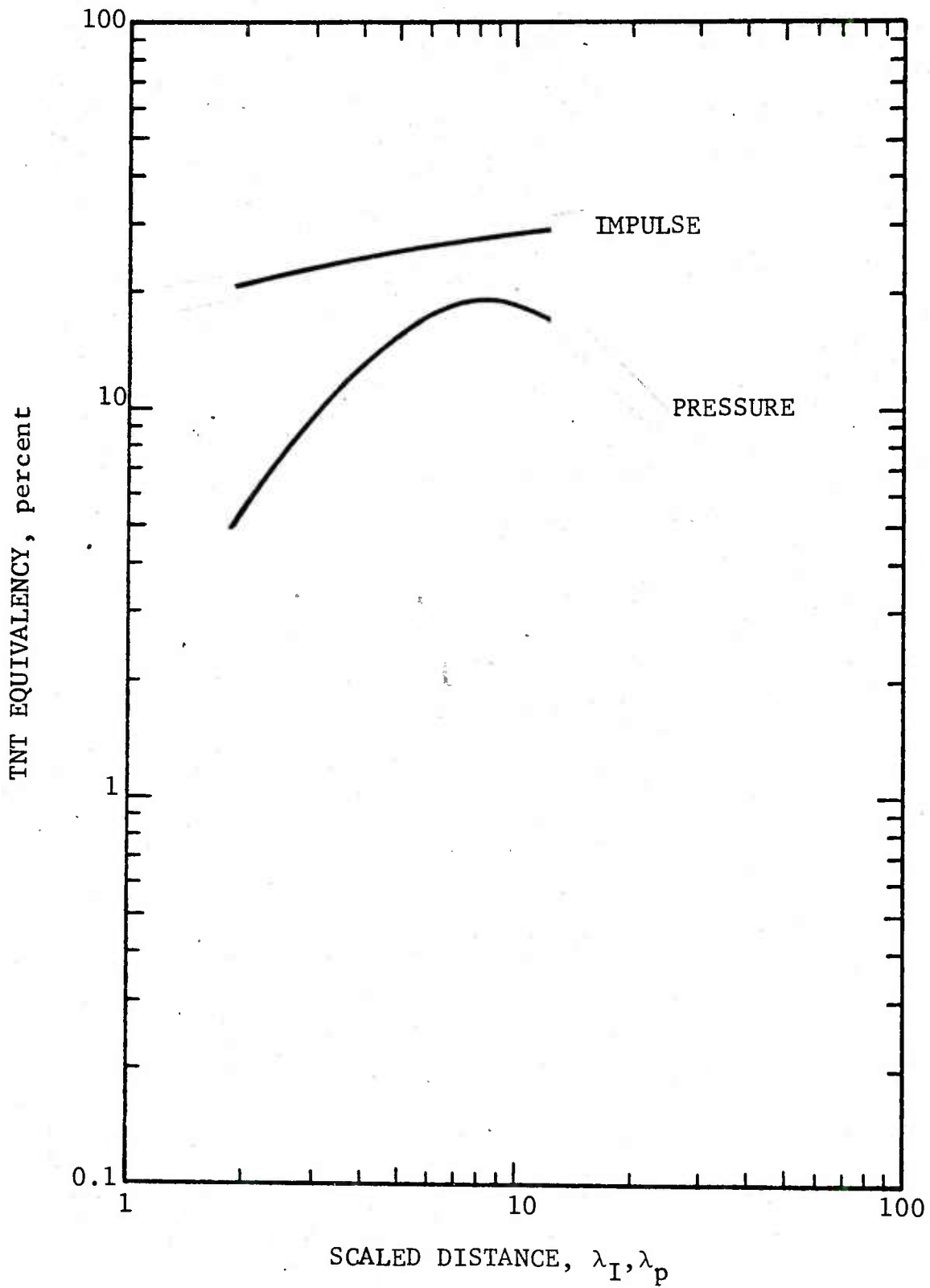

Figure C.18 PRESSURE AND IMPULSE EQUIVALENCY; TESTS CON-6,7,8
64 lb BLACK POWDER, 0.024 lb TETRYL BOOSTER

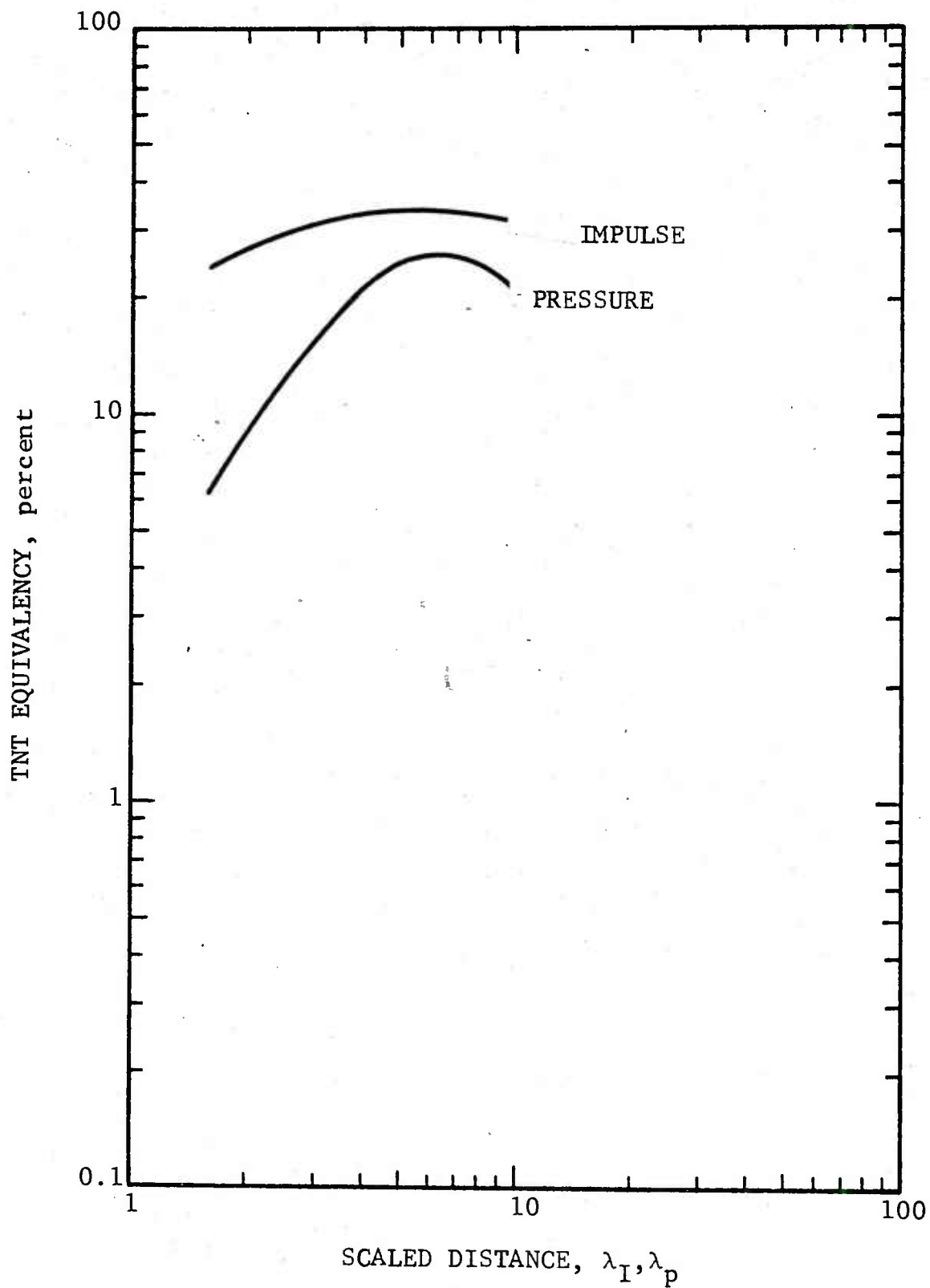

Figure C.19 PRESSURE AND IMPULSE EQUIVALENCY; TESTS CON-9,10
140 lb BLACK POWDER, 0.024 lb TETRYL BOOSTER

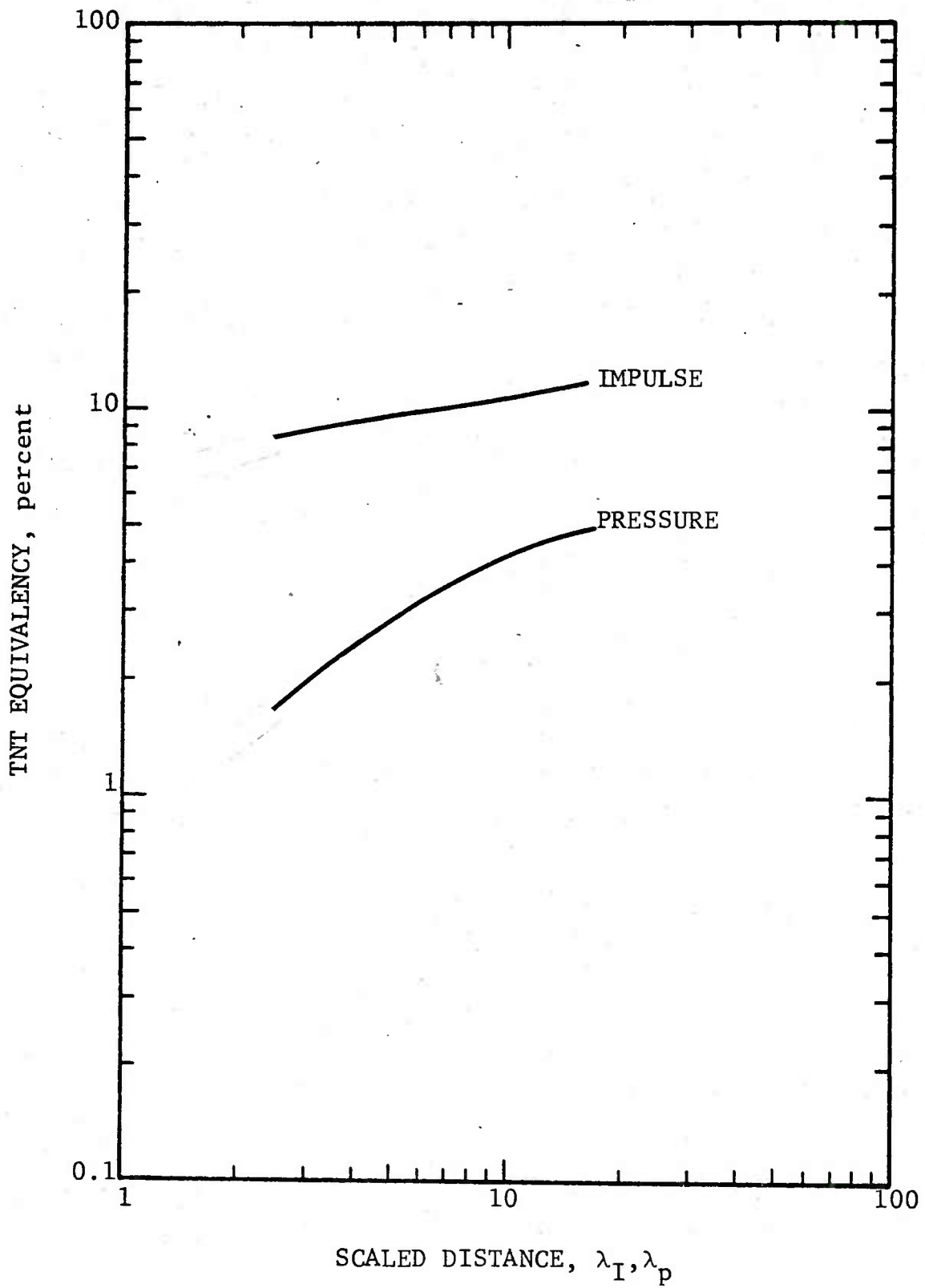

Figure C.20 PRESSURE AND IMPULSE EQUIVALENCY; TESTS CON-11,12
27 lb JET MILLED MATERIAL, 0.024 lb TETRYL BOOSTER

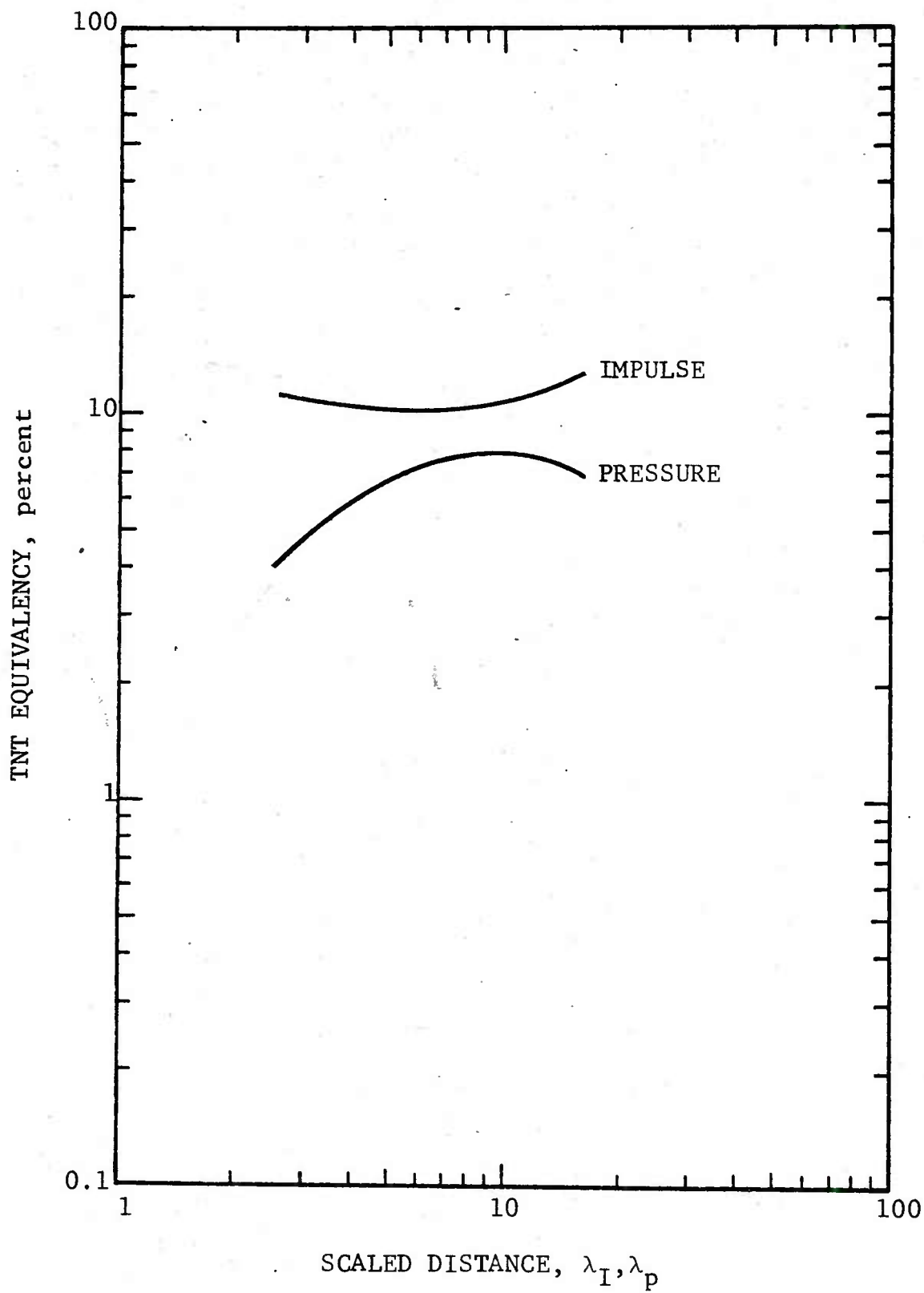

Figure C.21 PRESSURE AND IMPULSE EQUIVALENCY; TESTS SQ-1,2,3
27 1b BLACK POWDER, SQUIB INITIATED

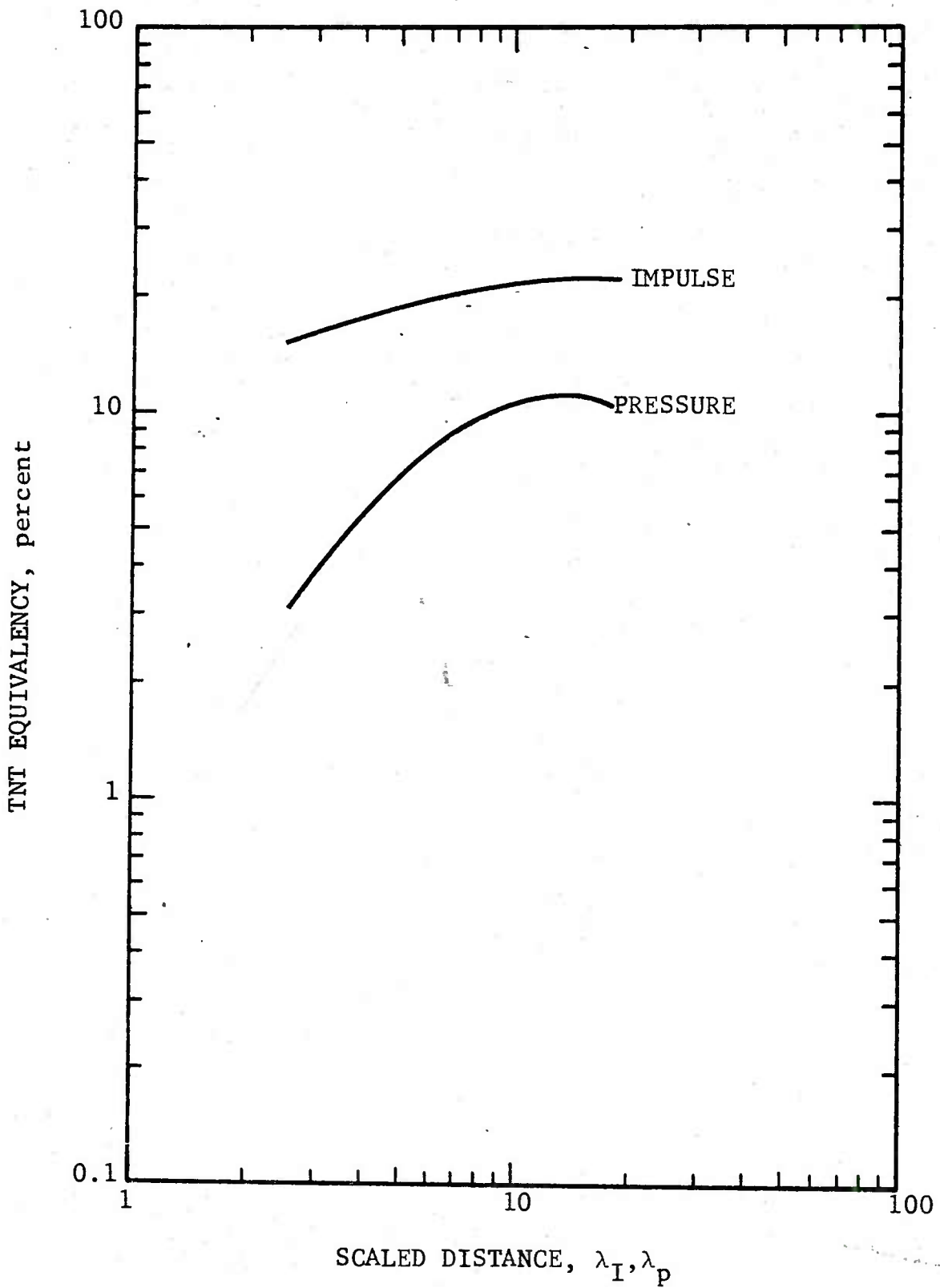

Figure C.22 PRESSURE AND IMPULSE EQUIVALENCY; TESTS SQ-4,5
27 1b JET MILLED MATERIAL, SQUIB INITIATED

APPENDIX D
INSTRUMENTATION
by
Richard P. Joyce

APPENDIX D
INSTRUMENTATION
by Richard P. Joyce

CONTENTS

		<u>Page</u>
D.1	General	D-1
D.2	Pressure Measuring Systems	D-1
D.3	Recording Instrument	D-2
D.4	Pressure Impulse Measurements	D-2
D.5	Data Reproduction	D-3
D.6	Block Diagram	D-3
D.7	Calibration Procedures	D-5

FIGURE

D.1	Block Diagram of Record/Reproduce Instrumentation	D-4
-----	---	-----

D.1 GENERAL

Pressure-time functions were monitored at locations as described in Volume I. The pressure-time signals were integrated to produce impulse-time functions. Data signals were recorded on magnetic tape and reproduced on an oscillograph recorder. The following subsections contain a description of the instrumentation equipment, calibration technique and computational procedure employed on the test program.

D.2 PRESSURE MEASURING SYSTEMS

The pressure measuring systems employed in the test program were manufactured by Photocon Research Products (PRP). These systems consist of three elements: the Dynagage (DG605D), a transmission line, and the pressure transducer (Type 752A).

The Photocon Type 752-50 psig transducer has a dynamic range of 0 to 50 psig and frequency response of 0 to 10 kHz. The diaphragm of the transducer, in conjunction with an insulated stationary electrode, forms an electrical capacitor. The pressure to be measured is applied to the diaphragm, causing a change in capacitance proportional to the applied pressure. The transducer capacitance and a built-in inductance form a tuned radio-frequency circuit. The tuned circuit is line-coupled, by means of a low impedance cable, to a Dynagage system consisting of an oscillator-detector circuit and a cathode-follower amplifier. The changes in capacitance produce changes in the diode detector impedance, and thereby produce a signal voltage proportional to the applied pressure.

The transducers were removed from their water-cooled flame shields and placed in a mounting adapter. The adapter was designed to provide flush mounting of the diaphragm. The electrical insulation material was used to break ground loops, thus reducing interference caused by stray pickup and intercarrier beats.

The transducers were installed flush with the ground surface in mechanically isolated steel mounting plates on the centerlines of a 75-ft-long by 10-ft-wide concrete slab. Pressure measurements

were made at six stations along the blast gage line. The transmission lines were run, in conduit in the near-field and above-ground in the farfield, to the instrumentation trailer.

D.3 RECORDING INSTRUMENT

Hewlett Packard (HP) Model 8875A differential amplifiers were used to condition the data signals for magnetic tape recording. These units were used to provide a voltage gain and impedance match between the pressure measuring system and magnetic tape recorder.

The data signals were dual recorded by using two magnetic tape recorders; an Ampex CP-100 and an Ampex AR-200. The CP-100 was considered the primary recorder. The recording levels on this machine were adjusted so that the anticipated signal levels would produce a full scale recording. The AR-200 was used as a "back-up" for the case where the actual signals were greater than anticipated. The recording levels on this machine were adjusted so that the anticipated data signals would produce a one-fifth of full scale recording. The instrumentation equipment proceeding the recorders had the required dynamic range to accommodate both recorders.

The recording format was the same for both recorders; thirteen (13) FM recording tracks were used for data recording, and a single channel of direct recording was used for time base signals. Data recorded on the AR-200 was reproduced on the CP-100, when required. Both tape recorders conform to specifications for the IRIG intermediate band.

D.4 PRESSURE IMPULSE MEASUREMENTS

The pressure impulse is defined as the area under the pressure time history

$$I(t) = \int_0^t P(t) dt$$

where P is the pressure and t is the time.

The signal voltage at the output of the Model 8875A amplifier is an electrical analog of the pressure-time history. This signal was used as input to a Tektronix Type O operational amplifier, where the electrical integration was performed. The integrated signal was amplified and in turn, recorded on the magnetic tape recorders.

D.5 DATA REPRODUCTION

Oscillograph reproductions of the magnetic tape recordings were made by employing Consolidated Electrodynamics Corp. (CEC) Type 1-172 Driver Amplifiers to drive a CEC Type 5-124 Recording Oscillograph. The oscillograph was equipped with CEC Type 7-363 galvanometers.

The pressure data were recorded at a tape speed of 60 ips and reproduced at a tape speed of 1-7/8 ips, resulting in a frequency division of 32. The oscillograph paper speed was 32 ips. For these conditions, the oscillograph has a horizontal resolution of 976 μ sec/in. and an effective frequency response from dc to 20 kHz, referred to real time.

D.6 BLOCK DIAGRAM

A simplified block diagram of the record/reproduce instrumentation system is shown in Figure D.1. Two data channels are shown; a pressure recording channel and an impulse recording channel. In the test program, six (6) pressure recording channels and six (6) impulse recording channels were employed.

In addition to the equipment described, the monitoring and signal control equipment is shown. The data channels were monitored and an electrical calibration signal was recorded on each data track immediately preceding each test run. The electrical calibration signal is a voltage simulation of a predetermined impulse or pressure level. This signal is used in data reduction and to verify the integrity of the record/reproduce system.

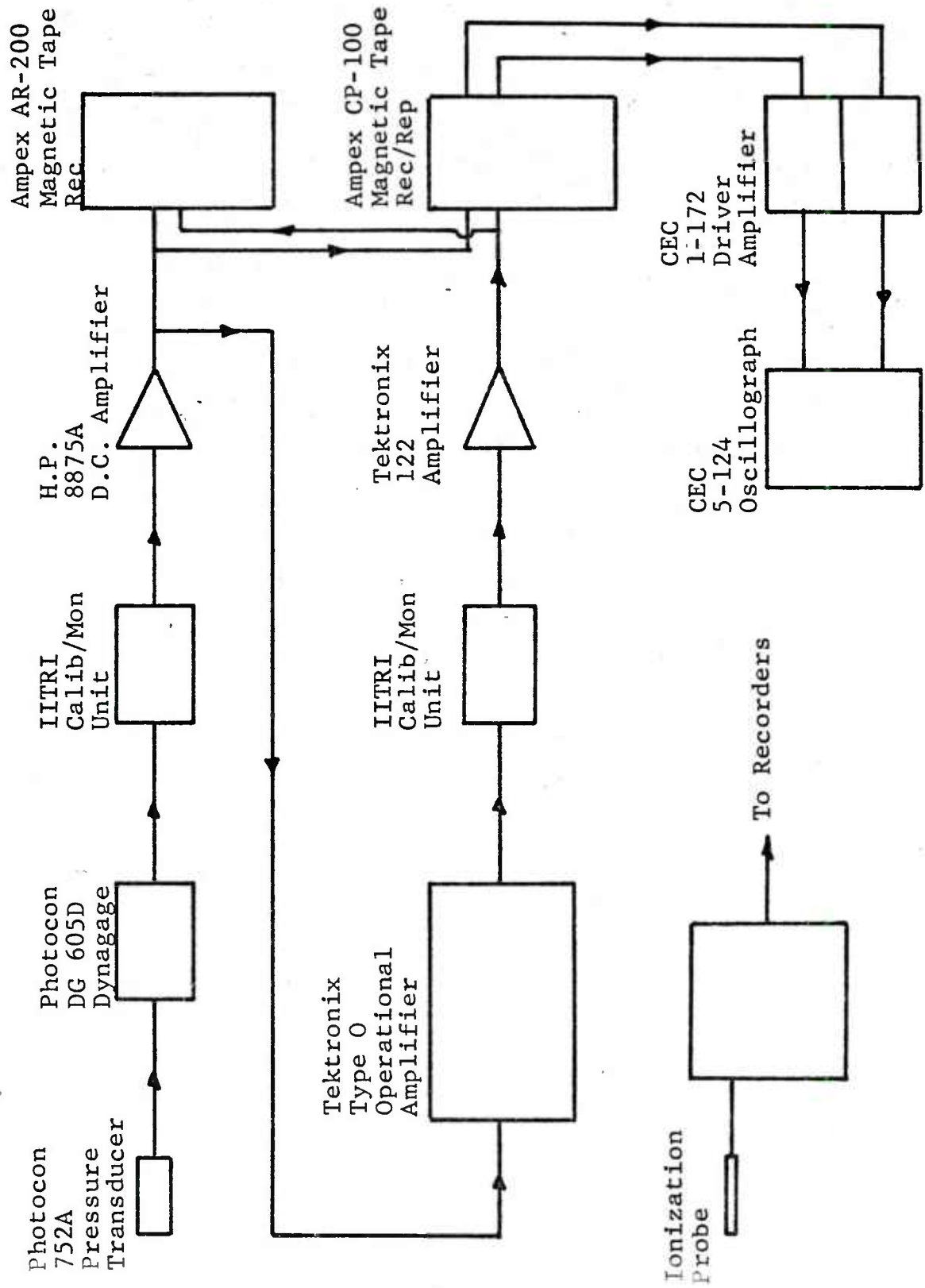

Figure D1 Block Diagram of Record/Reproduce Instrumentation

D.7 CALIBRATION PROCEDURES

The primary purpose of the calibration series is to establish sensitivity factors for each pressure measuring system. A precisely known pressure is applied to the transducer. The applied pressure causes a voltage rise at the output of the Dynagage Amplifier. The sensitivity factor (k) is the output voltage from the Dynagage (V) divided by the applied pressure P.

$$K = \frac{V}{P} \text{ (Volts/psi)}$$

The Photocon systems were calibrated at five points in the range 0 to 50 psi. The quantity K for the range is the arithmetic mean of the values of K determined at all the points.

APPENDIX E
DATA POINT EQUIVALENCES

APPENDIX E

DATA POINT EQUIVALENCIES

CONTENTS

	<u>Page</u>
E.1 General	E-1
E.2 Nomenclature	E-1

TABLES

E.1 Raw Data Equivalency	E-2
Booster Only Tests (BO-)	E-2
Unconfined Tests (UNC-)	E-8
Confined Tests (CON-)	E-9
Squib Tests (SQ-)	E-12

E.1 GENERAL

Pressure and impulse equivalency were computed for each of the measured data points given in Appendix A. Because of the scatter in the raw data, which is amplified when equivalencies are calculated, these results are not considered as useful as that based on the "fitted" data and presented in Appendix C. However, for the sake of completeness, these equivalencies are presented in this appendix.

E.2 NOMENCLATURE

The letter R used in table E.1 is the radial distance from the charge to the gauge.

Table E.1 RAW DATA EQUIVALENCY

	R (ft)	Pressure Equivalency (%)	Impulse Equivalency (%)
25 lb. Black Powder, 0.025 lb.	120 Deg.	<u>Cone C-4 Booster, BO - 5, 6</u>	
	6.00	3.67	12.59
	8.98	3.58	9.34
	12.79	6.00	10.45
	17.75	6.40	10.87
	22.63	8.26	12.17
	47.61	7.04	9.86
	6.00	3.67	12.07
	8.98	3.76	10.38
	12.79	6.44	11.52
	17.75	7.17	11.78
	22.63	7.84	14.02
	46.71	6.19	12.80
25 lb. Black Powder, 0.50 lb.	120 Deg.	<u>Cone C-4 Booster, BO - 8, 9</u>	
	6.00	4.72	23.31
	8.98	5.93	15.61
	12.79	10.04	16.27
	17.75	12.09	17.02
	22.63	13.62	19.68
	46.71	8.63	17.04
	6.00	5.41	25.22
	8.98	6.10	17.23
	12.79	10.19	18.25
	17.79	6.20	19.03
	22.63	11.62	20.01
	46.71	10.20	18.39

Table E.1 RAW DATA EQUIVALENCY

	R (ft)	Pressure Equivalency (%)	Impulse Equivalency (%)
25 lb. Black Powder, 0.50 lb. Cylindrical C-4 Booster, BO - 13, 12			
	6.00	7.08	27.17
	8.98	7.72	17.11
	12.79	10.27	18.25
	17.75	12.52	19.03
	22.63	12.44	21.49
	46.71	9.84	18.91
	8.98	6.28	23.22
	12.79	6.97	16.36
	17.75	8.92	20.05
	22.63	9.04	22.68
	46.71	8.46	14.45
25 lb. Black Powder, 0.50 lb C-4 Cone and Cylindrical Booster, BO - 8, 9, 13, 12			
	6.00	4.72	23.31
	8.98	5.93	15.61
	12.79	10.04	16.27
	17.75	12.09	17.02
	22.63	13.62	19.68
	46.71	8.63	17.04
	6.00	5.41	25.22
	8.98	6.10	17.23
	12.79	10.19	18.25
	17.75	6.20	19.03
	22.63	11.62	20.01
	46.71	10.20	18.39
	6.00	7.08	27.17
	8.98	7.72	17.11
	12.79	10.27	18.25
	17.75	12.52	19.03
	22.63	12.44	21.49
	46.71	9.84	18.91
	8.98	6.28	23.22
	12.79	6.97	16.36
	17.75	8.92	20.05
	22.63	9.04	22.68
	46.71	8.46	14.45

Table E.1 RAW DATA EQUIVALENCY

	R (ft)	Pressure Equivalency (%)	Impulse Equivalency (%)
27 lb. Black Powder, 11 Gram Tetryl Booster, BO - 14, 15			
	4.00	.45	5.22
	6.98	1.10	5.24
	10.79	1.77	5.05
	15.75	2.39	5.24
	20.63	2.23	5.43
	44.71	1.88	5.29
	4.00	.51	5.68
	6.98	1.01	4.94
	10.79	1.65	5.05
	15.75	1.88	5.51
	20.63	1.81	5.19
	44.71	1.62	4.89
75 lb. Black Powder, 0.50 lb. C-4 Cylindrical Booster, BO - 16, 18			
	9.00	5.77	17.73
	15.79	7.13	14.72
	20.75	8.43	14.97
	25.63	9.09	17.83
	49.71	9.16	17.51
	11.98	5.65	14.95
	15.79	8.97	15.81
	20.75	9.93	15.49
	25.63	10.83	17.08
	49.71	8.96	15.75

Table E.1 RAW DATA EQUIVALENCY

	R (ft)	Pressure Equivalency	Impulse Equivalency
75 lb. Black Powder, 0.50 lb. C-4 Cylindrical Booster, BO - 17, 19SP			
	9.00	7.81	23.12
	15.79	8.97	16.02
	20.75	10.51	17.29
	25.63	9.42	17.83
	49.71	10.51	15.16
	9.00	7.59	20.47
	15.79	7.80	16.63
	20.75	9.45	17.63
	25.63	11.91	19.54
	49.71	10.73	19.10
75 lb. Black Powder, 1.0 lb. C-4 Cylindrical Booster, BO - 20, 21			
	9.00	13.30	38.58
	15.79	12.90	22.79
	20.75	17.70	23.90
	25.63	16.47	28.01
	49.71	12.99	22.39
	9.00	11.26	35.23
	15.79	12.48	23.25
	20.75	15.75	22.69
	25.63	15.94	26.05
	49.71	12.99	22.56

Table E.1 RAW DATA EQUIVALENCY

	R (ft)	Pressure Equivalency	Impulse Equivalency
75 lb. Black Powder, 1.50 lb. Cylindrical C-4 Booster, BO - 31, 30			
	12.00	13.21	35.23
	14.98	15.37	23.78
	18.79	19.40	29.38
	23.75	17.94	24.31
	28.63	23.65	32.60
	52.71	16.23	29.29
	14.98	15.37	26.95
	18.79	17.32	25.04
	23.75	20.48	23.96
	28.63	19.04	28.08
	52.71	13.85	27.69
25 lb. Black Powder, 1.00 Cylindrical C-4 Booster, BO - 32, 33			
	6.00	9.71	38.11
	8.98	16.38	36.91
	12.79	21.96	30.75
	17.75	24.21	28.46
	22.63	25.56	33.67
	46.71	16.04	29.99
	6.00	13.38	41.17
	8.98	12.34	38.73
	12.79	16.72	31.41
	17.75	25.98	26.71
	22.63	23.39	32.31
	46.71	14.78	29.76

Table E.1 RAW DATA EQUIVALENCY

	R (ft)	Pressure Equivalency	Impulse Equivalency
25 lb. Black Powder, 0.540 lb. Cylindrical PBX Booster BO - 36, 37			
	6.00	8.94	33.08
	8.98	13.74	23.31
	12.79	13.62	24.56
	17.75	16.25	23.03
	22.63	17.88	25.61
	46.71	10.56	23.45
	6.00	9.04	39.80
	8.98	11.77	23.59
	12.79	14.66	35.20
	17.75	16.50	22.76
	22.63	15.46	23.86
	46.71	8.95	21.99
150 lb. Black Powder, 1.50 lb. Cylindrical C-4 Booster, BO - 40			
	12.00	8.48	31.40
	14.98	9.49	20.27
	18.79	10.44	20.49
	23.75	15.43	20.09
	28.63	16.93	28.27
	52.71	13.45	28.66
150 lb. Black Powder, 3.0 lb. Cylindrical C-4 Booster, BO - 41, 42			
	12.00	13.17	39.70
	14.98	15.15	31.51
	18.79	16.16	35.65
	23.75	24.01	29.10
	28.63	23.51	28.44
	52.71	18.84	26.66
	12.00	12.69	50.41
	14.98	13.03	36.76
	18.79	14.06	25.60
	23.75	22.27	25.95
	28.63	18.70	28.72
	52.71	16.34	25.91

Table E.1 RAW DATA EQUIVALENCY

	R (ft)	Pressure Equivalency	Impulse Equivalency
27 lb Black Powder, 0.024 lb. Tetryl Ignitor Unconfined on Stand-Off, UNC - 2			
	4.00	-	.210
	6.98	-	.219
	10.79	-	.202
	15.75	-	.233
	20.63	-	.267
	44.71	-	.236
64 lb. Black Powder, 0.024 lb. Tetryl Ignitor Unconfined on Stand-Off, UNC - 4			
	4.00	-	.039
	6.98	-	.040
	10.79	-	.032
	15.75	-	.039
	20.63	-	.060
	44.71	-	.038
27 lb. Black Powder, 0.024 lb. Tetryl Ignitor Unconfined, UNC -5			
	4.00	.305	4.17
	6.98	.620	3.69
	10.79	.934	3.99
	15.75	1.18	3.88
	44.71	10.04	9.11

Table E.1 RAW DATA EQUIVALENCY

	R (ft)	Pressure Equivalency	Impulse Equivalency
140 lb Black Powder, 0.024 lb. Tetryl Ignitor, Unconfined, UNC - 6			
	7.5	.669	10.62
	10.48	1.00	11.24
	14.29	1.69	8.28
	19.25	3.31	12.16
	24.13	6.11	12.44
	48.21	6.50	12.29
27 lb Jet Milled Material, 0.024 lb Tetryl Ignitor, Unconfined, UNC -9			
	4.00	-	3.75
	6.98	-	3.37
	10.79	-	3.29
	15.75	-	3.64
	20.63	-	4.27
	44.71	-	3.15
8 lb Black Powder, 0.024 lb Tetryl Ignitor, Confined, CON - 1, 2			
	15.59	13.60	16.29
	20.55	14.12	17.92
	25.43	14.55	24.79
	49.51	13.60	19.95
	4.00	1.58	19.29
	6.98	5.15	17.08
	10.79	8.27	18.67
	44.71	13.15	24.78

Table E.1 RAW DATA EQUIVALENCY

	R (ft)	Pressure Equivalency	Impulse Equivalency
27 lb. Black Powder, 0.024 lb. Teteryl Ignitor, Confined, CON - 3, 4, 5			
	7.50	7.54	22.42
	10.48	8.01	17.84
	14.29	11.71	19.38
	19.25	14.70	20.50
	24.13	15.36	23.79
	48.21	12.08	22.83
	7.50	5.52	19.01
	10.48	6.27	15.44
	14.29	8.78	16.07
	19.25	10.52	16.27
	24.13	11.69	18.64
	48.21	22.69	16.94
	7.50	5.76	22.42
	10.48	7.61	18.11
	14.29	10.28	18.25
	19.25	11.35	18.46
	24.13	13.39	20.38
	48.21	10.68	17.30

Table E.1 RAW DATA EQUIVALENCY

	R (ft)	Pressure Equivalency	Impulse Equivalency
64 lb Black Powder, 0.024 lb. Tetryl Ignitor, Confined, CON - 6, 7, 8			
	7.50	5.07	23.54
	10.48	7.06	20.58
	14.29	12.59	22.14
	19.25	15.83	24.86
	24.13	17.19	25.62
	48.21	20.37	25.71
	7.50	5.46	23.24
	10.48	7.52	18.52
	14.29	8.64	20.59
	19.25	16.64	23.01
	24.13	17.81	40.13
	48.21	14.97	29.27
	7.50	5.38	20.03
	10.48	7.56	19.07
	14.29	12.77	21.14
	19.25	16.43	22.70
	24.13	15.80	24.64
	48.21	14.34	28.07
140 lb. Black Powder, 0.024 lb Tetryl Ignitor, Confined, CON -9, 10			
	8.50	7.37	22.24
	15.29	15.36	33.08
	20.25	24.17	31.55
	25.13	24.84	35.26
	49.21	22.45	32.17
	8.50	5.78	24.80
	15.29	13.12	30.09
	20.25	20.86	32.19
	25.13	24.62	31.25
	49.21	19.46	32.17

Table E.1 RAW DATA EQUIVALENCY

	R (ft)	Pressure Equivalency	Impulse Equivalency
27 lb. Jet Milled Material, 0.024 lb. Tetryl Ignitor, Confined , CON - 11, 12			
	7.50	1.55	5.91
	10.48	1.73	6.54
	14.29	2.42	7.34
	19.25	2.90	7.27
	24.13	3.26	9.44
	48.21	3.76	11.53
	7.50	2.03	9.76
	10.48	2.24	15.06
	14.29	2.99	10.11
	19.25	4.13	11.43
	24.13	4.58	12.77
	48.21	5.86	11.79
27 lb. Black Powder, Squib Ignitor, Confined, SQ - 1, 2, 3			
	7.50	4.72	12.90
	10.48	5.77	10.90
	14.29	6.14	11.31
	19.25	7.49	11.10
	24.13	13.27	13.51
	48.21	7.55	14.29
	7.50	4.20	11.86
	10.48	4.59	9.55
	14.29	5.70	9.14
	19.25	7.30	10.64
	24.13	7.92	11.21
	48.21	6.60	12.22
	7.50	3.64	11.52
	10.48	4.73	9.01
	14.29	5.89	8.99
	19.25	5.93	10.34
	24.13	6.81	12.09
	48.21	5.72	11.07

Table E.1 RAW DATA EQUIVALENCY

	R (ft)	Pressure Equivalency	Impulse Equivalency
27 1b. Jet Milled Material, Squib Ignitor, Confined, SQ - 5, 4			
	7.50	3.22	
	10.48	3.48	Impulse EQ Not Given on Output
	14.29	5.46	
	19.25	8.83	
	24.13	10.28	
	48.21	10.62	
	7.50	2.98	
	10.48	5.17	
	14.29	7.05	
	19.25	8.90	
	24.13	9.61	