

AD-A044 526

ARMY COMMAND AND GENERAL STAFF COLL FORT LEAVENWORTH KANS F/G 20/5
THE MULTIPLE INTEGRATED LASER ENGAGEMENT SYSTEM (MILES) AND THE--ETC(U)
JUN 77 A MUNERA

UNCLASSIFIED

NL

1 of 2

ADA044526

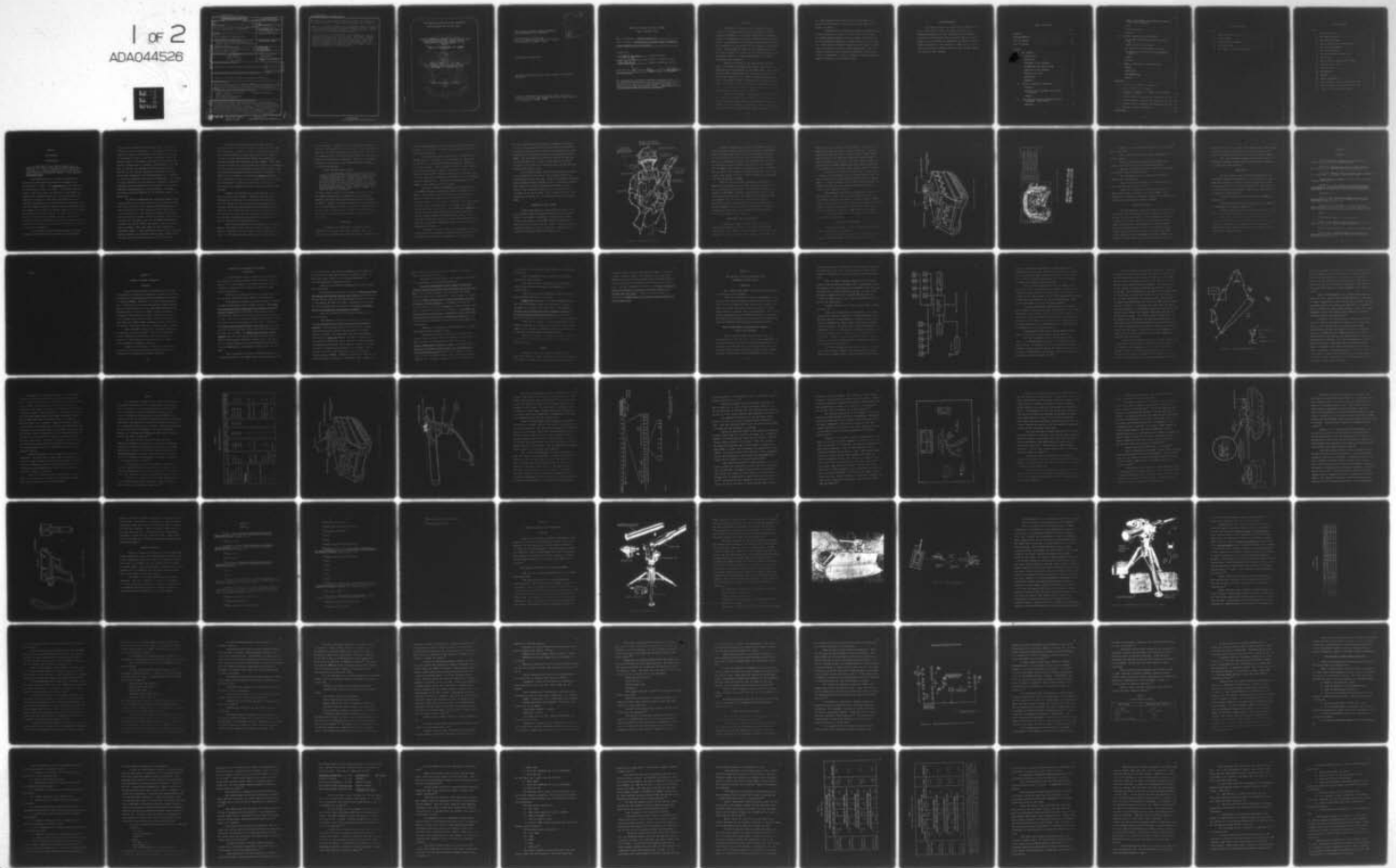

UNCLASSIFIED

SECURITY CLASSIFICATION OF THIS PAGE (When Data Entered)

AK E

| REPORT DOCUMENTATION PAGE | | READ INSTRUCTIONS BEFORE COMPLETING FORM |
|-----------------------------------------------------------------------------------------------------------------------------------------------------------------------------------------------------------------------------------------------------------------------------------------------------------------------------------------------------------------------------------------------------------------------------------------------------------------------------------------------------------------------------------------------------------|-----------------------|------------------------------------------------------------------------------------------------|
| 1. REPORT NUMBER 6 | 2. GOVT ACCESSION NO. | 3. RECIPIENT'S CATALOG NUMBER |
| 4. TITLE (and Subtitle) The Multiple Integrated Laser Engagement System (MILES) and the TOW ARTEP, | | 5. TYPE OF REPORT & PERIOD COVERED Final Report, 10 Jun 77 |
| 7. AUTHOR(s) 10 Antonio Munera, III MAJ, USA | | 6. PERFORMING ORG. REPORT NUMBER |
| 9. PERFORMING ORGANIZATION NAME AND ADDRESS Student at the U.S. Army Command and General Staff College, Fort Leavenworth, Kansas 66027 | | 8. CONTRACT OR GRANT NUMBER(s) |
| 11. CONTROLLING OFFICE NAME AND ADDRESS U.S. Army Command and General Staff College, ATTN: ATSW-SE 11 | | 10. PROGRAM ELEMENT, PROJECT, TASK AREA & WORK UNIT NUMBERS |
| 14. MONITORING AGENCY NAME & ADDRESS (If different from Controlling Office) 12 168p. | | 12. REPORT DATE 10 June 1977 |
| 16. DISTRIBUTION STATEMENT (of this Report) Approved for public release; distribution unlimited. | | 13. NUMBER OF PAGES |
| 17. DISTRIBUTION STATEMENT (of the abstract entered in Block 20, if different from Report) Approved for public release; distribution unlimited. | | 15. SECURITY CLASS. (of this report) UNCLASSIFIED |
| 18. SUPPLEMENTARY NOTES Master of Military Art and Science (MMAS) Thesis prepared at CGSC in partial fulfillment of the Masters Program requirements, U.S. Army Command and General Staff College, Fort Leavenworth, KS., 66027 | | 15a. DECLASSIFICATION/DOWNGRADING SCHEDULE D D C APPROVED SEP 26 1977 UNCLASSIFIED |
| 19. KEY WORDS (Continue on reverse side if necessary and identify by block number) LASER Engagement Simulators Training Simulations Training Devices TOW Guided Missile System TOW Training Standards | | |
| 20. ABSTRACT (Continue on reverse side if necessary and identify by block number) The Multiple Integrated Laser Engagement System (MILES) is a training device which will permit two sided casualty assessment in the 'mock' battlefield of training. MILES will revolutionize military training methods and techniques. Using MILES, the individual soldier receives immediate feedback as to the effects of his actions on the battlefield. By 'killing' his opponent with the eye safe laser if he performs correctly and being see reverse side | | |

AD A 044 526

DDC FILE COPY

DD FORM 1 JAN 73 1473

EDITION OF 1 NOV 65 IS OBSOLETE

UNCLASSIFIED

SECURITY CLASSIFICATION OF THIS PAGE (When Data Entered)

037260

JP

UNCLASSIFIED

SECURITY CLASSIFICATION OF THIS PAGE(When Data Entered)

"killed" if he errs, actions which will permit the soldier to perform effectively in the modern battlefield are reinforced.

What is the impact of MILES on the Mechanized Infantry Battalion Army Training and Evaluation Program (ARTEP) 7-45 as it relates to antiarmor training and evaluation of the TOW guided missile section in the mechanized infantry company?

A significantly revised TOW squad/section ARTEP training and evaluation outline is the end result of this study. Changes include use of MILES to: refine gunner tracking techniques, pinpoint defensive positions, check range cards, check fire control techniques, and establish a pass/fail criteria for two-sided engagements in terms of number of "enemy" killed vs. number of TOWs lost in the TOW section.

UNCLASSIFIED

SECURITY CLASSIFICATION OF THIS PAGE(When Data Entered)

THE MULTIPLE INTEGRATED LASER ENGAGEMENT
SYSTEM (MILES) AND THE TOW ARTEP

A thesis presented to the Faculty of the U.S. Army
Command and General Staff College in partial
fulfillment of the requirements for the
degree

MASTER OF MILITARY ART AND SCIENCE

by

ANTONIO MUNERA III, MAJ, USA
B.S., Virginia Military Institute, 1964
M.S., Michigan State University, 1972

Fort Leavenworth, Kansas
1977

AD BELLUM PACE PARATI

The Multiple Integrated Laser Engagement
System (MILES) and the TOW ARTEP

Antonio Munera III, MAJ, USA
U.S. Army Command and General Staff College
Fort Leavenworth, Kansas 66027

| | |
|---------------------------------|---------------------------------------------------|
| ACCESSION IN | |
| HTIS | White Section <input checked="" type="checkbox"/> |
| DDC | Sub Section <input type="checkbox"/> |
| UNANNOUNCED | <input type="checkbox"/> |
| JUSTIFICATION | |
| BY | |
| DISTRIBUTION AVAILABILITY CODES | |
| Dist. | AVAIL. RES. OR SPECIAL |
| A | |

Final Report 10 June 1977

(Unclassified) Approved for public release; distribution
unlimited.

A Master of Military Art and Science thesis presented to the
faculty of the U.S. Army Command and General Staff College,
Fort Leavenworth, Kansas 66027

MASTER OF MILITARY ART AND SCIENCE

THESIS APPROVAL PAGE

Name of candidate Antonio Munera III
Title of thesis The Multiple Integrated Laser Engagement
System (MILES) and the TOW ARTEP

Approved by:

[Signature], Research Advisor
[Signature], Member, Graduate Faculty
Don Martin, Member, Consulting Faculty

Accepted this 26th day of May 1977 by [Signature]
[Signature], Director, Master of Military
Art and Science.

The opinions and conclusions expressed herein are those of the individual student author and do not necessarily represent the views of either the U.S. Army Command and General Staff College or any other governmental agency. (Reference to this study should include the foregoing statement.)

ABSTRACT

The Multiple Integrated Laser Engagement System (MILES) is a training device which will permit two-sided casualty assessment in the "mock" battlefield of training. MILES will revolutionize military training methods and techniques. Using MILES, the individual soldier receives immediate feedback as to the effects of his actions on the battlefield. By "killing" his opponent if he performs correctly and being "killed" if he errs, actions which will permit the individual soldier to perform effectively in the modern battlefield are reinforced.

MILES is currently in the engineering development phase of the materiel acquisition process, and production quantities will be available in the early 1980s. The system uses low power eyesafe lasers to simulate the effects of direct fire weapons such as tanks and antitank missile systems. Each weapon system is equipped with a laser and laser energy detectors. When a "kill" occurs, the target vehicles laser is deactivated, a smoke grenade is ignited, and a continuous tone is sounded for one minute.

Assuming that MILES is operational within the U.S. Army, what is the impact of this system on the Mechanized Infantry Battalion Army Training and Evaluation Program (ARTEP) 7-45 as it relates to antiarmor training and evaluation of the TOW in the Mechanized Infantry Company? The TOW

is a Tube-launched, Optically-tracked, Wire-command link guided missile capable of defeating any known armor out to ranges of 3,000m.

A significantly revised TOW squad/section ARTEP training and evaluation outline is the end result of this study. It includes ARTEP changes in terms of tasks, conditions and training/evaluation standards. Changes include use of MILES to: refine gunner tracking techniques out to ranges of 3,000m, pinpoint defensive positions, check range cards, check fire control techniques, and establish a pass/fail criteria for two-sided engagements in terms of number of "enemy" killed vs. number of TOWs lost in the TOW section.

ACKNOWLEDGEMENTS

The author extends his appreciation to Colonel E. E. Perry, Major Boyd A. Jones, and Major Don Martin, Jr., Consulting Faculty, for their assistance as the Research Committee; to Major Larry Word, U.S. Army Training Support Center, for his patience in explaining the latest trends in MILES development; to Mrs. Marilyn V. Slack for her typing efforts; and to Mrs. Barbara Munera for her patience during the course of this endeavor.

TABLE OF CONTENTS

| | Page |
|------------------------------------------------------------------------------------|------|
| ABSTRACT | iii |
| ACKNOWLEDGEMENTS | v |
| LIST OF TABLES | viii |
| LIST OF FIGURES | ix |
| CHAPTER | |
| I. THE PROBLEM | 1 |
| INTRODUCTION | 1 |
| BACKGROUND | 4 |
| STATEMENT OF THE PROBLEM | 6 |
| ASSUMPTIONS AND DELIMITATIONS | 8 |
| QUESTIONS TO BE ANSWERED | 9 |
| VALUE OF THE STUDY | 12 |
| DEFINITIONS | 13 |
| ENDNOTES | 14 |
| II. REVIEW OF RELATED LITERATURE | 16 |
| OVERVIEW | 16 |
| QUESTIONS TO BE ANSWERED AND RELATED LITERATURE | 17 |
| SUMMARY | 20 |
| III. THE PROPOSED MULTIPLE INTEGRATED LASER ENGAGEMENT SYSTEM (MILES) | 22 |
| OVERVIEW | 22 |

| | Page |
|------------------------------------------------------------------------------------|------|
| COMBAT DEVELOPMENTS EXPERIMENTATION COMMAND'S DIRECT FIRE SIMULATOR | 22 |
| MILES | 30 |
| SYSTEM LIMITATIONS | 44 |
| ENDNOTES | 45 |
| IV. FINDINGS (ANALYSIS AND EVALUATION) | 48 |
| TOW SYSTEM DESCRIPTION AND TACTICAL EMPLOY- MENT | 48 |
| THREAT TACTICS AND EQUIPMENT | 64 |
| TOW MEASURES OF EFFECTIVENESS AND MILES | 70 |
| THE ARTEP AS IT RELATES TO TOW PERFORMANCE STANDARDS | 89 |
| SUMMARY | 92 |
| ENDNOTES | 95 |
| V. SUMMARY, CONCLUSIONS, RECOMMENDATIONS | 100 |
| SUMMARY | 100 |
| CONCLUSIONS | 105 |
| RECOMMENDATIONS | 112 |
| ENDNOTES | 115 |
| APPENDIXES | 116 |
| 1. Level 2 and 3 ARTEP 7-45 Standards | 117 |
| 2. Level 1 ARTEP 7-45 Standards | 118 |
| 3. Excerpts from ARTEP 71-2 (DRAFT) for TOW Squad- Levels 1, 2, and 3 | 121 |
| 4. Proposed Level 3 Training and Evaluation Outline. | 124 |
| 5. Proposed Level 2 Training and Evaluation Outline. | 134 |
| 6. Proposed Level 1 Training and Evaluation Outline. | 143 |
| 7. Thoughts on Other Simulations | 148 |
| BIBLIOGRAPHY | 152 |

LIST OF TABLES

| Table | Page |
|----------------------------------------------|------|
| 1. Weapon Characteristics | 31 |
| 2. Scoring Table | 56 |
| 3. Soviet Antitank Weapons | 68 |
| 4. 1976 Base Cases | 79 |
| 5. 1976 Cases with Four TOWs Added | 80 |

LIST OF FIGURES

| Figure | Page |
|-------------------------------------------------------|------|
| 1. M16A1 Rifle System | 7 |
| 2. M113 APC/TOW System | 10 |
| 3. TOW Ballistic Blanket | 11 |
| 4. Vehicle Mounted DFS Configuration | 24 |
| 5. Typical DFS Engagement | 27 |
| 6. M113 APC/TOW System | 32 |
| 7. TOW Missile Laser Transmitter | 33 |
| 8. Code Format | 35 |
| 9. Loader Control Assembly Front Panel | 38 |
| 10. M60A1/A3 Tank System | 41 |
| 11. Controller Gun | 43 |
| 12. TOW Assembly | 49 |
| 13. APC/TOW | 51 |
| 14. Target Engagement | 52 |
| 15. Guided Missile System Training Set XM70 | 54 |
| 16. Motorized Rifle Battalion in the Attack | 66 |
| 17. Indirect Fire Simulation System | 150 |

CHAPTER I

THE PROBLEM

INTRODUCTION

. . . in World War II less than 25 percent of an infantry line employed hand weapons effectively when under fire . . . due to awareness of the problem and training, active weapons participation in our infantry line in Korea rose beyond 55 percent. S.L.A. Marshall: Men Against Fire.

Since World War II our efforts in training the individual soldier have been directed at improving his effectiveness in combat. The Train Fire system, adopted in the early 60's, was such an effort. It replaced the known-distance (KD) rifle ranges of World War II and Korean War vintage where bullseye targets were set at prescribed distances for a soldier to fire upon. KD firing was not a realistic representation of the battlefield situation. Train Fire uses subdued silhouette targets that are presented without warning to the soldier at varying ranges out to 350 meters. The soldier is required to detect the target and then to engage it within a limited period of time. This system provides realism in marksmanship training and more effectively conditions the soldier for the type of situation he is likely to encounter in combat.¹

In the field of heavy antitank weapons, the 106mm recoilless rifle (RR) was the mainstay of the Mechanized

Infantry Rifle Company until the early 70's. RR training included firing the weapon with a .30 subcaliber device on a 1,000 inch range, burst-on-target adjustment of fire using the subcaliber device on stationary and moving targets at varying ranges to 640 meters, and service firing using the service cartridge out to a range of 1,100 meters.² For the sake of economy, the subcaliber device was used for the majority of the training instead of the service cartridge. RR tactical employment in training consisted of a series of non-live fire offensive and defensive operations. The outcome of these operations was determined in a subjective manner by evaluators and consequently did not provide the crew with a realistic representation of the battlefield. The 106mm recoilless rifle was replaced by the TOW heavy antitank weapon system.

The TOW is a Tube-launched, Optically tracked, Wire-command link guided missile system with a 3,000 meter range. Due to the high cost of the individual TOW missile (approximately \$3,000) most of the training with the TOW is done using the M70 training set. The M70 uses an infrared (IR) light source mounted on a target vehicle to provide a line-of-sight reference for the gunner, who uses an instructor console to determine how well he tracks the target. Live fire is conducted annually. Each crew fires one live missile at a stationary target.³ This provides the TOW crew with adequate gunnery training, but tactical training still suffers from the same lack of realism experienced by the RR crews.

At least once a year, Army units from squad to battalion level are tested to obtain a measure of their combat proficiency. In 1975, in order to provide more specific and uniform performance goals toward which a unit should be trained, the Army Training Tests (ATTs) were replaced by the Army Training and Evaluation Program (ARTEP). "The ARTEP defines the basic unit training mission in terms of performance objectives which are accomplished through decentralized training using the performance oriented training technique."⁴ The ARTEP is better because it establishes minimum performance objectives against which a unit or weapons crew can be tested. This eliminates the ambiguity experienced in the past of determining the standards to which a weapons crew was to be trained.

Weapons crew training is an important part of each unit's training requirements. Generally speaking, crew training and testing can be divided into two categories: (1) crew firing; and (2) crew tactical employment. As an example, TOW Antitank Squad ARTEP training/evaluation standards for crew firing are based on scores obtained using the M70 training set under various conditions.⁵ Evaluation of crew tactical training has generally been subjective in nature, performed by evaluators/umpires.

Crew firing capabilities are evaluated in an objective manner. The gunner either hits the target or misses. He attains a numerical score equivalent to the total number of hits. If the numerical score exceeds the minimum standard,

the crew passes. Evaluation of crew tactical employment and tactical effectiveness is more difficult. Subjective evaluations are too crude and imperfect to provide the crew and the evaluator with a good feel for how well the crew performed under the training/test conditions. There is no immediate feedback to the crew as to the effects of their actions on the "mock" battlefield.

S.L.A. Marshal suggests that,

. . . the individual soldier first goes into battle without the facts he most requires--the simple details of common human experience on the field of battle. As a result, he goes to the supremely testing experience of his lifetime almost as a total stranger . . . the price for failure is paid all up and down the line; men go into action the first time haltingly and gropingly, as if they were lost at night in the deep woods. Lives are wasted unnecessarily. Time is lost. Ground that might be taken is overlooked.⁶

Is there a way to create the interplay of friend vs. foe on the "mock" battlefield of training in order to increase weapons crew effectiveness and minimize initial casualties in combat? Equally important, assuming that the battlefield can be realistically created in training, to what standards do you train the weapons crew? Efforts in the U.S. Army in the past few years have been oriented to answering these two questions.

BACKGROUND

Development of techniques to simulate two-sided engagements in training have been conducted under the auspices of the Training and Doctrine Command (TRADOC) Office

of the Program Management for Tactical Engagement Simulation Systems, a part of the U.S. Army Training Support Center at Fort Eustis, Virginia.

The Squad Combat Operations Exercise (Simulation), or SCOPES, which is currently in use throughout the Army, was one of the first training techniques developed. SCOPES is an infantry system. Kills are assessed when a number painted on an opposing player's helmet is identified by the firer through a high powered telescope mounted on his weapon. The number is passed to a controller who relays it to a controller with the opposing unit. The player who corresponds to the number is then removed from the action.

Realistic Training (REALTRAIN) is an adaptation of the SCOPES technique to tanks and armored personnel carriers (APC). A controller with each vehicle verifies kills and misses by using telescopes that are boresighted to the vehicle's main gun. If a kill is assessed, the vehicle number is radioed to a controller with the opposing side, and the vehicle is taken out of action. Both SCOPES and REALTRAIN can only be used with small units, have no night capability, require a large number of controllers and radios, and suffer from lack of realism; however, even with these deficiencies, they are a significant improvement over the use of subjective evaluations by umpires.

In order to add more realism to training, the Army is in the process of developing a laser system that will permit the immediate assessment of casualties by opposing sides.

Low power eye-safe lasers are used to simulate the effects of direct fire weapons such as the M-16, TOW and M-60 tank. A prototype laser system for direct fire simulation was first introduced by the Combat Developments Experimentation Command (CDEC). The prototype was tested and improved by CDEC and was successfully used in 1972. Since that time improved versions of the direct fire simulation laser system have been developed and used by CDEC.

The Training Support Center at Fort Eustis, Virginia began looking into the possible use of laser systems in training about three years ago. Today, the Multiple Integrated Laser Engagement System (MILES) is in the engineering development phase of the materiel acquisition process. It is expected that production quantities of the system will be available in the early 1980's. This research focuses on the integration of MILES into the Mechanized Infantry Battalion ARTEP.

STATEMENT OF THE PROBLEM

MILES engagements are characterized by laser transmitter-target sensor "pairings" of varying time duration. Kills or near misses are determined by laser codes which provide a hierarchy of effects. A near miss activates an audio tone on the player for one second. A kill activates a continuous audio alarm and a pyrotechnic signal, and deactivates the laser transmitter (Figure 1).⁸



Figure 1. M16A1 Rifle System

Increased capabilities provided by MILES will revolutionize military training methods and techniques. MILES will permit the individual soldier to receive immediate feedback as to the effects of his actions on the battlefield and will permit more realistic training. The question might be asked: How will Army training programs be affected by the development of MILES? What changes, if any, must be made in ARTEP's, such as that of the Mechanized Infantry Battalion? This broad field is the subject of studies being conducted in conjunction with the development of MILES.

With the advent of laser engagement simulators, the ARTEP must be examined to determine the effect of such a system on training and evaluation. Of particular interest are changes in TOW ARTEP standards. Assuming that the U.S. Army has an operational Multiple Integrated Laser Engagement System (MILES), what is the impact of this system on the Mechanized Infantry Battalion Army Training and Evaluation Program (ARTEP) 7-45 as it relates to antiarmor training and evaluation of the TOW in the Mechanized Infantry Company? This is the subject of this study.

ASSUMPTIONS AND DELIMITATIONS

In subsequent chapters MILES will be described in detail with emphasis on how it is used with TOW and M-60 tank systems. The MILES used with the M-60 tank is described; because the tank is the most likely target for the TOW. The

M-60 will be used in lieu of threat armor. Descriptions of MILES characteristics will be a "best guess" as to what the final system will look like. Based on these assumed MILES characteristics, the Mechanized Infantry Battalion ARTEP will be studied as it relates to the TOW. Where changes are suggested due to MILES capabilities, data will be collected and analyzed, and recommended ARTEP changes will be proposed.

The TOW to be discussed in this study is that which is found in the Mechanized Infantry Company (TOE 7-47H). The TOW is mounted on a modified M-113 armored personnel carrier (APC). It will be assumed that the APC has been modified to provide the TOW crew with protection from the effects of indirect fire (Figures 2 and 3).

TOW employment tactics are categorized as offensive and defensive. Because the emphasis today is on the use of antitank weapons in the "active defense," proposed ARTEP changes will be limited to this tactical situation. The active defense combines both offensive and defensive tactics and is the best vehicle for examining MILES impact on the ARTEP.

A mid-intensity conflict in a European environment will be the scenario used.

QUESTIONS TO BE ANSWERED

Step-by-step answers to the following questions will lead to a solution to the problem

-What are the characteristics of the MILES as it is used with the M-113 APC mounted TOW and the M-60 tank?

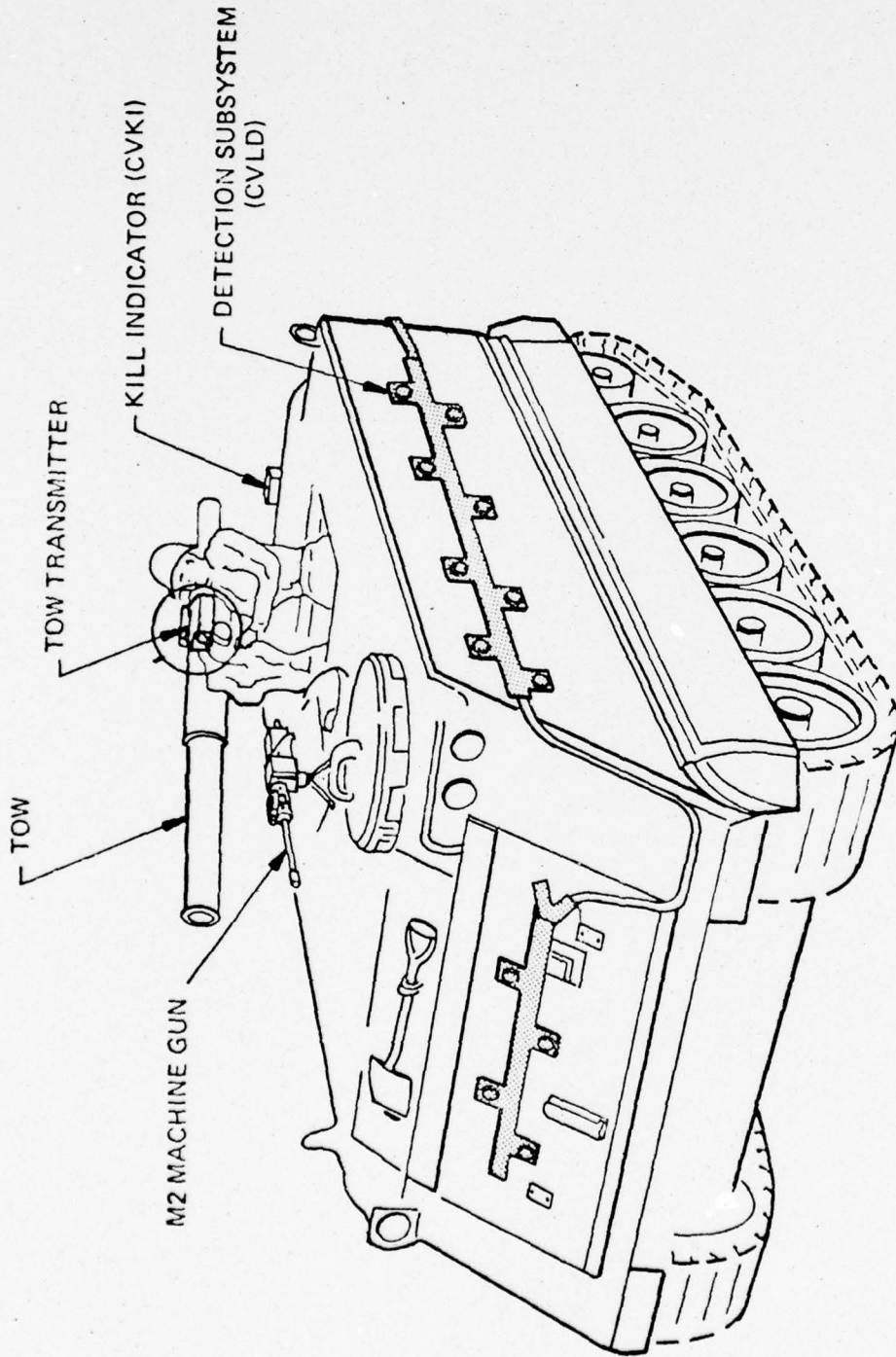
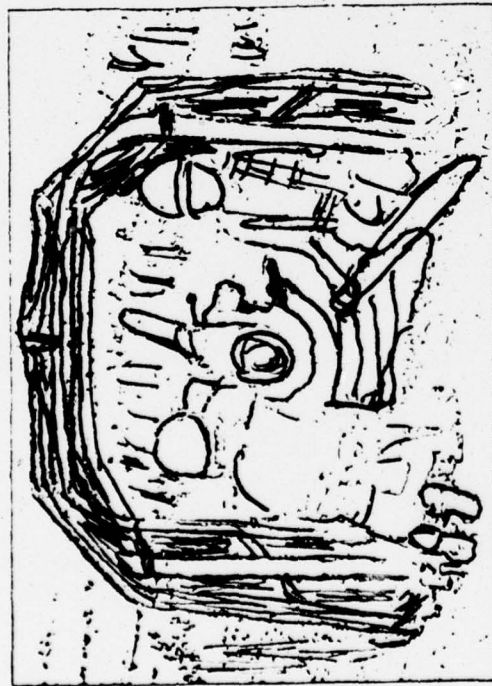

Figure 2. M113 APC/TOW System.



• TOW missile gunners will get added protective cover beginning January... TOW CAP (Cover, Artillery Protection) is designed to shield soldiers against heavy artillery fragments... Consists of tubular steel frame covered by ballistic nylon fabric... Can be mounted on M13A1 armored personnel carrier, or ground mounted, as shown left.

Figure 3. TOW Ballistic Blanket.

COPY AVAILABLE TO DDC DOES NOT PERMIT FULLY LEGIBLE PRODUCTION

-What are the technical characteristics of the M-113 APC mounted TOW?

-How is the TOW section tactically employed in the active defense?

-What are the threat tactics and equipment most likely to be encountered in a European environment?

-What are the measures of effectiveness of the M-113 APC mounted TOW in antitank battle?

-How can MILES be used to quantify the APC TOW measures of effectiveness?

-What are the current ARTEP 7-45 standards for the M-113 APC TOW, and what do they test?

-Based on the answers to these questions and with MILES operational in the Army, how should ARTEP 7-45 be changed as it relates to antiarmor training and evaluation of the TOW in the Mechanized Infantry Company?

VALUE OF THE STUDY

General William E. Depuy has stated, "In the next war we will not have the luxury of time to mobilize our forces. We must win the first battle." This challenge is made more difficult by the fact that we will be required to defeat a numerically superior enemy equipped with modern weapons. That "first battle" can be won if it is fought by highly trained officers and enlisted men. The use of the MILES system along with well thought-out and applied ARTEP standards in training will help provide the highly qualified

soldiers who will win on that future battlefield. Additionally, providing realistic training to the proper standards will insure minimum casualties during the initial days of combat.

This study parallels similar efforts now beginning at the TRADOC Training Support Center at Fort Eustis, Virginia. It supplements those efforts.

DEFINITIONS

The term "laser" stands for Light Amplification by Stimulated Emission of Radiation. In this context the eye-safe laser referred to emits "invisible light" in the near infrared portion of the frequency spectrum.¹¹ This "light" is very intense and can activate "laser light" detectors out to ranges of 3,000 meters.¹²

A laser is eye-safe if the beam will not damage the naked eye.

A laser pairing occurs when a laser energy "detector" is illuminated by a laser transmitter.¹³

A laser detector is an electronic device which senses laser energy. Sometimes these are referred to as sensors.¹⁴

The active defense is characterized by defense in depth and the use of numerous battle positions. In the active defense, enemy forces are canalized into preestablished ambush zones where maximum firepower can be brought to bear upon him by friendly forces.

CHAPTER I

ENDNOTES

¹S.L.A. Marshall, Men Against Fire (New York: William Morrow & Company, 1966), pp. 9-10.

²FM 23-82, 106mm Recoilless Rifle M40A1 w/C1-C3, Hq., Department of the Army, May 1964, pp. 122-31.

³TC 23-23, TOW Heavy Antitank Weapon System w/C1-C2, Hq., Department of the Army, July 1970, pp. 3&7.

⁴Understanding the ARTEP, Command and General Staff College, 1976, p. 7.

⁵ARTEP 7-45, Army Training and Evaluation Program for Mechanized Infantry Battalion and Combined Arms Task Force w/C1, Hq., Department of the Army, 9 September 1975.

⁶Marshall, p. 37.

⁷Larry J. Lam, Final Instrumentation Report for Experiment 23.1, (Fort Ord, CA.: BDM Scientific Support Laboratories, March 1973), p. 1.

⁸Design Review Conference. Multiple Integrated Laser Engagement System (MILES). Electro-Optical Systems, XEROX Corporation, Pasedina, California, 23 September 1976.

⁹Ibid.

¹⁰Periodical Clipping. Source Unknown.

¹¹Alan Lytel, ABC's of Lasers and Masers (New York: Howard W. Sams & Co., Inc., January 1963), p. 1.

¹²Design Review Conference. MILES, 23 September 1976.

¹³George Roper, Final Instrumentation Report for Experiment 43.6 (Fort Ord, CA.: BDM Scientific Support Laboratories, 1972), p. 2.

¹⁴Ibid.

CHAPTER II

REVIEW OF RELATED LITERATURE

OVERVIEW

A review of the related literature must start with the collection of sufficient documents to support a technical description of the proposed Multiple Integrated Laser Engagement System (MILES). The system is still being developed, and to some extent, the system description contained herein will be a "best guess" as to the final MILES configuration. Technical data describing the MILES is based on Combat Developments Experimentation Command (CDEC) experimentation with a similar laser system, design reviews of the MILES, interviews with MILES program management project officers and the author's experience with first generation CDEC systems.

After the MILES is described, literature relating to the TOW system will be examined. TOW related literature includes TOW system description, tactical employment, measures of effectiveness and Army Training and Evaluation Program (ARTEP) performance standards.

Finally, a review must be conducted of literature describing the threat tactics and equipment we expect to encounter in a European mid-intensity conflict.

QUESTIONS TO BE ANSWERED AND RELATED

LITERATURE

In reviewing the related literature, documentation was collected to support answers to the questions posed in Chapter I. In this chapter, the related literature will be discussed in terms of how it assists in answering each individual question.

-What are the characteristics of the MILES as it is used with the M-113 APC mounted TOW and the M-60 tank?

In answering this question, heavy reliance is placed on CDEC experimentation with a similar system. CDEC Final Instrumentation Report, Experiment 43.6 (Attack Helicopter Daylight Defense) describes CDEC's vehicle mounted Direct Fire Simulator (DFS) as it was first used in experimentation in 1972. The report contains a summary of DFS design, tests, and final system configuration as used in the experiment. CDEC Final Instrumentation Report, Experiment 23.1 describes the tests of the prototype infantry DFS conducted September-December 1972 at CDEC. The Final Instrumentation Report, HELLFIRE describes the system improvements incorporated into CDEC's vehicle mounted DFS June-December 1974. The author was the Project Engineer for instrumentation for Experiment 23.1 and HELLFIRE and is intimately familiar with the CDEC DFS.

Data concerning the status of MILES development was derived from notes of the MILES Design Review Conference held

23 September 1976. Additional information on the MILES was obtained from an interview conducted in November 1976 with Major Larry Word, Office of the Program Management for Tactical Engagement Simulation Systems.

-What are the technical characteristics of the M-113 APC mounted TOW?

TOW technical description is found in Training Circular (TC) 23-23, TOW Antitank Weapons System w/C1-C2 and engineering and service tests of the TOW conducted at the White Sands Missile Range, New Mexico in 1969. Probability of hit data and time of flight can be extracted from TC 7-24 Antiarmor Tactics and Techniques for Mechanized Infantry.

-How is the TOW section tactically employed in the active defense?

TOW employment doctrine is discussed in detail in TC 7-24, Antiarmor Tactics and Techniques for Mechanized Infantry. Additionally, numerous other military training publications discuss TOW tactical employment in varying degrees of detail. The March-April and September-October 1976 issues of Infantry magazine each have a special tactics section which relates the latest doctrine of TOW employment in conjunction with tanks and mechanized infantry. Detailed test data on TOW tactical employment is available from test results of the Tactical Effectiveness Test of Antitank Guided Missiles (TETAM). TETAM was conducted at CDEC and the Federal Republic of Germany in 1972-1973. Also results of a

TANK vs TOW test conducted by the 3d Infantry Division in Germany in 1972 will be used.

-What are the threat tactics and equipment most likely to be encountered in a European environment?

U.S. Army Intelligence Threat Analysis Detachment (USAITAD) Report No. 14-4-76, Military Operations of the Soviet Army is the primary document used to describe the Soviet tactics expected to be encountered. This document is supplemented by TRADOC Bulletin No. 1, Range and Lethality of U.S. and Soviet Antiarmor Weapons, 30 September 1975 and the "Special Tactics Section" of Infantry, September-October 1976. Soviet weapons and equipment are described in U.S. Army Command and General Staff College (USACGSC) Reference Book (RB) 30-2, Selected U.S. and Soviet Weapons and Equipment. Time to fire data for tanks are derived from U.S. Army manuals on tank gunnery.

-What are the measures of effectiveness of the M-113 APC mounted TOW in antitank battle?

Previously discussed literature on TOW and threat tactics will be used to derive TOW measures of effectiveness. Also, aspects of tank-antitank battles can be found in TR3-73, TETAM Model Verification Plan, 29 November 1973 and Analysis of Antiarmor Effectiveness with BLDM (Battalion Level Differential Model), April 1973. BLDM is a computer model used by the Combined Arms Combat Developments Agency (CACDA), Fort Leavenworth, Kansas to provide data on the

effectiveness of various M-113 APC TOW mixes in a European environment.

-How can MILES be used to quantify the APC TOW measures of effectiveness?

This question will be answered by an analysis of MILES characteristics as compared to TOW measures of effectiveness.

-What are the current ARTEP 7-45 standards for the M-113 APC TOW, and what do they test?

ARTEP 7-45 specifies the current standards for the M-113 APC TOW working as part of a mechanized infantry battalion or a combined arms task force. Additionally, FM 21-6, How to Prepare and Conduct Military Training and TC 21-5-2, Training Management Digest No. 2 discuss Army Training philosophy to include the use of training standards.

-Based on the answers to these questions and with MILES operational in the Army, how should the ARTEP 7-45 be changed as it relates to antiarmor training and evaluation of the TOW in the Mechanized Infantry Company?

Analysis of answers to previous questions will lead to the answer to this question, which is the solution to the stated problem.

SUMMARY

Literature exists in adequate quantities and sufficient variety to solve the problem. Field experimentation results, design review notes, interviews and personal

experience will be used to postulate the MILES. Field test reports, computer models, field manuals, and professional publications provide data describing TOW technical characteristics, techniques of employment, and measures of effectiveness. TOW test standards are listed in the Army Training and Evaluation Program for Mechanized Infantry Battalion and Combined Arms Task Force. Threat tactical doctrine is described in USAITAD Report No. 14-4-76, Military Operations of the Soviet Army.

CHAPTER III

THE PROPOSED MULTIPLE INTEGRATED LASER ENGAGEMENT SYSTEM (MILES)

OVERVIEW

This chapter will answer the first question leading to a solution to the problem.

-What are the characteristics of the MILES as it is used with the M-113 APC mounted TOW and the M-60 tank? The CDEC Direct Fire Simulator (DFS) will first be examined to obtain an insight into the principles involved in using laser systems to simulate two-sided engagements. The proposed system configuration for the MILES will then be discussed. The chapter will conclude with a discussion of MILES limitations in simulating tank and antitank weapons systems.

COMBAT DEVELOPMENTS EXPERIMENTATION COMMAND'S DIRECT FIRE SIMULATOR

CDEC's vehicle mounted DFS (hereafter DFS) was successfully used for the first time in CDEC Experiment 43.6, an attack helicopter vs. tracked vehicle experiment.¹ Subsequently, the DFS was used in the tank-antitank experiment Tactical Effectiveness of Antitank Guided Missiles (TETAM), September 1972-December 1973 and HELLFIRE, a helicopter

launched laser guided missile vs. tank experiment, conducted April-December 1974. This first generation vehicle mounted system was replaced by a second generation system in early 1977.

Tests of CDEC's infantry version of the DFS were conducted during October-December 1972. Recommended system improvements were identified and incorporated into the specifications for a second generation system. In early 1976, production quantities of the infantry DFS (60 ea) were received by CDEC, and the system was successfully used in a man vs. man experiment.

A block diagram of the vehicle mounted DFS is shown in Figure 4.²

-The laser transmitter is boresighted to the TOW or tank optical sight and consists of a Gallium Arsenide laser. The laser beam is 5 milliradians in diameter (5 meters at a range of 1,000 meters, 10m at 2,000m etc.) and is roughly circular in shape. The laser has a range of 5,000m with the probability of .2 to .9 depending on ambient temperature that one laser message will be detected by one laser detector (pairing). Decreasing the range, adding detectors and increasing the number of laser messages transmitted increase the probability of pairing.³

The laser message consists of five pulses. The five pulse coded message minimizes the possibility that random "noise" from sunlight will activate the system and provides

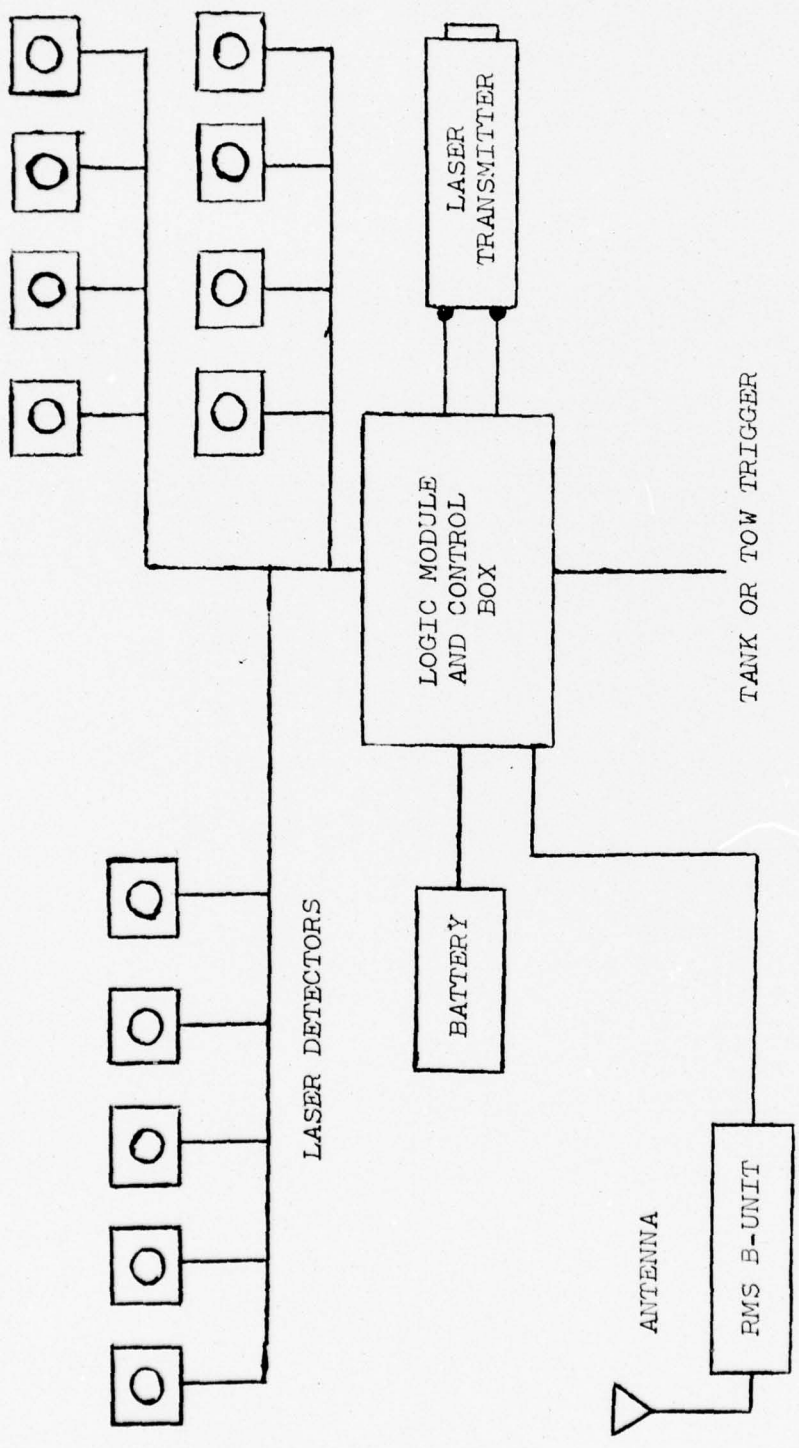

Figure 4. Vehicle Mounted DFS Configuration.

a means of discretely identifying the laser transmitter illuminating the detector. When fired, the laser is normally set to transmit 100 laser messages per second. This insures that at least one laser message will pair with one detector at a range of 5,000m during that second.⁴

-Three groups of laser detectors are placed on the vehicle to detect the incoming laser message. There are two 4 detector groups and one 5 detector group. Each detector responds to the laser energy received and produces an electrical message that corresponds to the laser coded message. This electrical message is sent to the logic module.⁵

-The logic module and control box are the "brains" of the system. They provide power distribution to the various components of the system, timing circuits that control the "laser on" time, and the logic circuits that convert ongoing activities in the DFS into a message that is transferred to the Range Measuring System (RMS) B-unit for transmittal via a telemetry link to a central computer.

-Rechargeable, heavy-duty, nickel-cadmium (NICAD) batteries are used to provide power to the system.

The DFS interfaces with the RMS through the RMS B-unit. The Range Measuring System is a ranging and telemetry system. In conjunction with a controlling computer, it provides position location data on all players equipped with a B-unit. Additionally, digital data can be sent to and from the central computer through the RMS.

Figure 5 depicts a typical DFS engagement. The TOW has engaged a tank with his laser transmitter. The fact that the TOW has fired is entered into the computer via the RMS telemetry link. The laser identification (ID) of the firing TOW has been preloaded into the computer. The detectors on the tank detect the laser energy and the laser ID of the firing TOW. This information is processed by the logic module of the DFS into a binary coded word that is transferred to the central computer via the telemetry link. The computer now knows that the TOW has illuminated the tank with his laser (paired the tank). It also knows the range from the TOW to the tank; because it is calculating position location for each vehicle once a second from ranging information provided by the telemetry system. The computer next calculates the time of flight of the TOW missile for that particular range. It then looks at the critical illumination period (CIP) which is a 3 second "window" around the time the missile should have impacted on the target. If the TOW is still illuminating the target with its laser during CIP, then a valid TOW-tank engagement has occurred.⁶

Based on the TOW-tank range, the computer goes through a probability of kill routine (rolls the dice) to determine the outcome of the engagement. If a kill is assessed, a message is sent to the tank informing him that he has been killed, and his laser is disabled by the computer. A controller on the tank throws a colored smoke grenade to inform

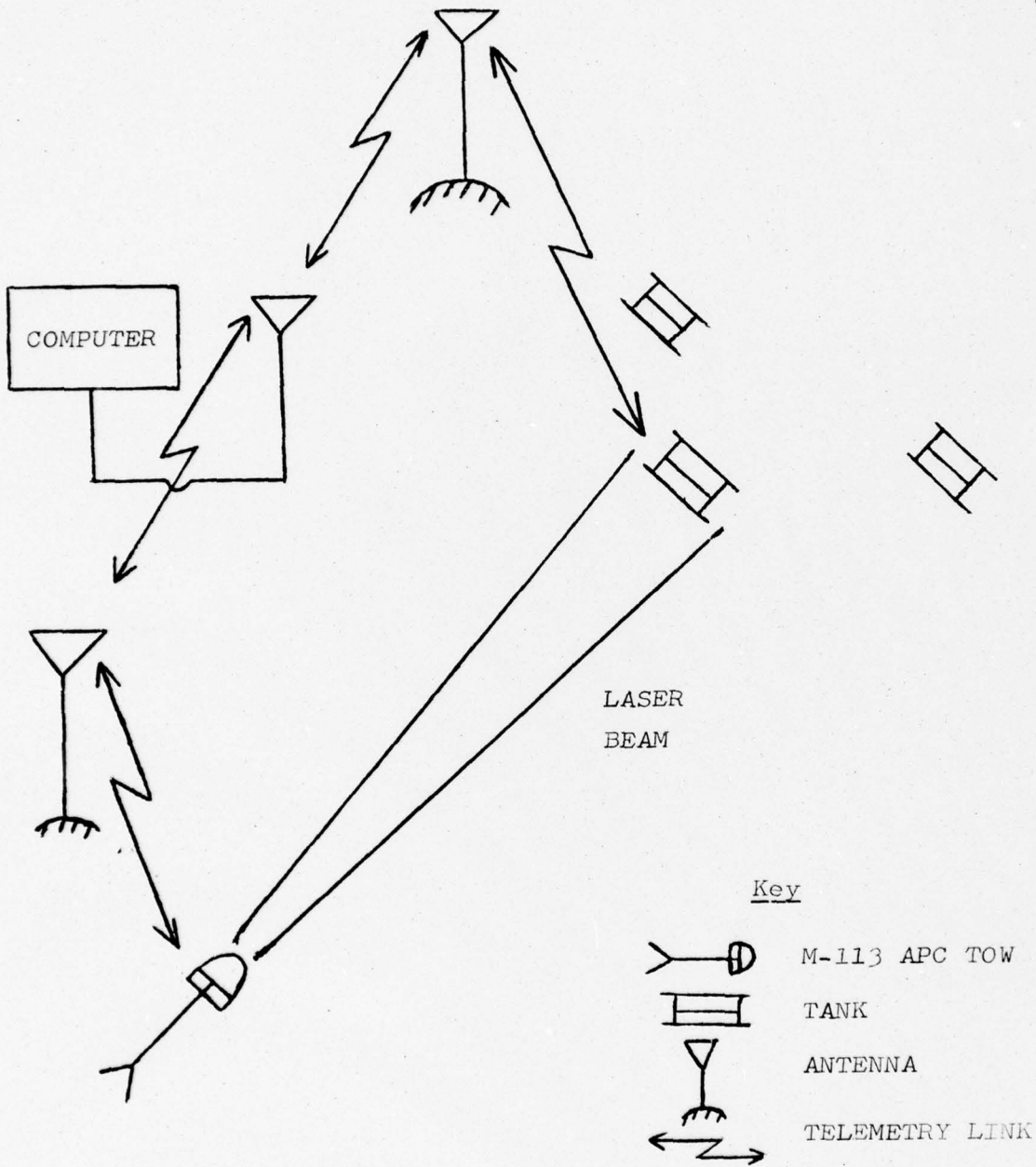

Figure 5. Typical DFS Engagement

the opposing player of the kill. At the time of missile impact, a message is sent to the TOW by the computer informing him that the missile has hit the target. If a "miss" is assessed by the computer, a message is sent to the tank informing him that he "survived" an engagement. The computer also reduces the number of rounds available to the TOW by one round.⁷

Tank to TOW engagements are similar except that the CIP is not used. When a tank simulates firing its main gun, the laser transmitter is turned on for three seconds. A valid engagement occurs if the target is "painted" by the laser at any time during that three second period of time. If a valid engagement occurs, the computer goes through the casualty assessment routine described above.⁸

Although it is rarely used by itself, the DFS can be used in a limited way without the RMS and the central computer. To use the DFS alone in two-wided play, kill probabilities for each type player are preset in the hardware, i.e., TOW-75 percent, TANK-50 percent, etc. When a pairing occurs, the kill or miss computations are done in the logic module of the DFS. If a kill is assessed, a 30 second intermittent tone is activated, and the target vehicle's laser is disabled. If a "miss" is assessed, a one second tone is activated. The major drawback in using the system in this fashion is that kill probabilities are constant with each type system, and variations in kill-probabilities as a function of range cannot be played.

Boresighting is accomplished prior to using the DFS to insure the laser transmitter is aligned to the gunsight and to provide the player with confidence in his DFS. To boresight, a small "pulse generator" is attached to the laser transmitter that places the laser in "continuous fire" (firing a nominal 10 laser message per second). The gunner then sights on a boresight panel equipped with laser detectors which is placed 750m-1,000m from the weapon system. The laser is adjusted until it is on target. Whenever the laser "pairs" with detectors on the boresight panel an intermittent tone is generated at the boresight panel for duration of pairing. The intermittent sound is transmitted to the individual adjusting the laser and to the gunner by means of standard military radios or telephones. The laser is adjusted until the gunner can traverse an equal distance left/right and up/down from the boresight panel before the intermittent sound goes off (pairing ceases).

Player confidence in the equipment he is using is important. For this reason a small light is placed at the end of the laser transmitter that goes on whenever the laser is fired. Similarly, prior to using the DFS each day, technicians using handheld laser guns check to insure that each laser detector is working.

This is the CDEC first generation vehicle mounted DFS. It is described to facilitate understanding of the less sophisticated and less expensive MILES.

MILES

As discussed in Chapter I, the development of laser engagement systems for use in training began in early 1973 under the auspices of the Training Support Center at Fort Eustis, Virginia. Advanced development models of the Multiple Integrated Laser Engagement System (MILES) were tested in 1975, and in April 1976 XEROX Corporation, Pasadena, California, was awarded the contract to design the engineering development version of the system.⁹ Production quantities of the system will be available in the early 1980's.¹⁰ Weapons to be simulated by MILES, and some system characteristics, are shown in Table 1.¹¹

The basis of issue for production quantities of MILES will probably be sufficient to outfit one Mechanized Battalion, one Armored Battalion, four companies of threat players, and a slice of the Armored Cavalry Squadron per Mechanized/Armored Division. This will permit the testing (as per the ARTEP) of one Mechanized and Armored Battalion per division at any one time.¹²

For purposes of this study, only the M-113 APC TOW and M-60 tank MILES will be considered. The MILES is still under development, and the system described in this chapter is a "best guess" as to what the final configuration will be.

Figure 6 is a schematic of the M-113 APC/TOW missile system equipped with MILES components. Figure 7 shows a closer look at the TOW laser transmitter.¹³

Table 1

Weapon Characteristics

| Weapons Simulated | Used by | Store Basic Load (rounds) | Firing Rate (RPM) | Burst (rounds) | Range of Simulator (Meters) | |
|----------------------------|-------------------------|---------------------------|-------------------|----------------|-----------------------------|-----------|
| | | | | | Kill | Near Miss |
| <u>Short Range</u> | | | | | | |
| M161A1 Rifle | Infantry | 210 | 650 | 30 | 5/25 to 460 | -- |
| M60 Machine Gun | Infantry | 600/1800 | 650 | 200 | 5/25 to 800 | 1100 |
| Coax Machine Gun | Tanks | 1800 | 650 | 200 | 5/25 to 800 | 1100 |
| M85 Machine Gun | Tanks | 1200 | 650 | 200 | 5/25 to 800 | 1600 |
| <u>Antiarmor</u> | | | | | | |
| Guns (Antitank): | | | | | | |
| 105 mm Gun | M60A1/A3 Tank | 63 | 12 | | 50/200 to 3000 | 3000 |
| 152 mm Gun | M60A2 and M551 AARV | 33 and 20 | 6 | | 50/200 to 2000 | 2000 |
| <u>Missiles (Antitank)</u> | | | | | | |
| Viper | Infantry | 4 | 6 | | 10 to 300 | 300 |
| Dragon | Infantry | 10 | 4 | | 50/200 to 1000 | 1000 |
| TOW | Infantry and Helicopter | 10 | 4 | | 50/200 to 3000 | 3000 |
| Shillelagh | M60A2 and M551 AARV | 13 and 9 | 6 | | 800 to 3000 | 3000 |

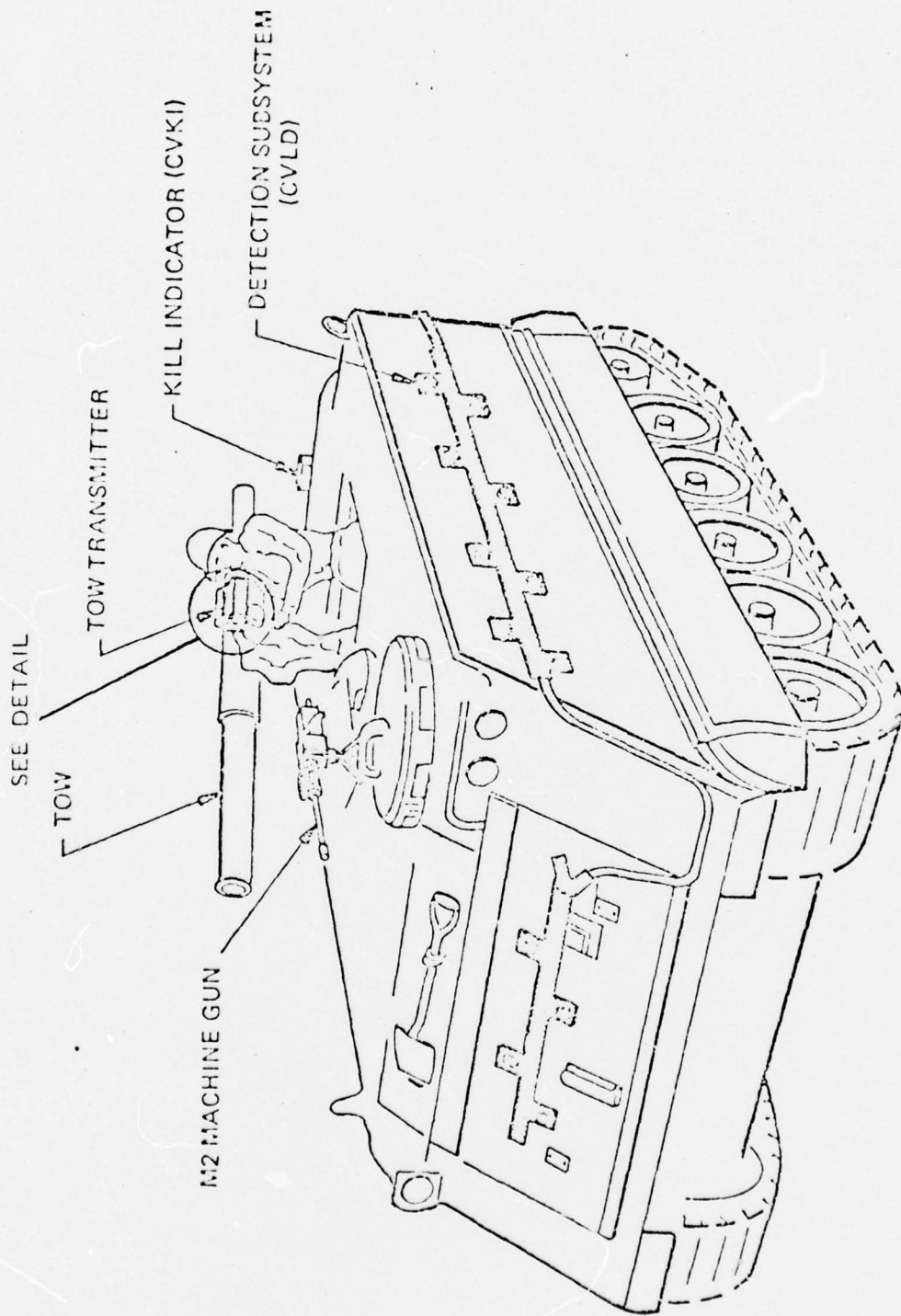

Figure 6. M113 APC/TOW System.

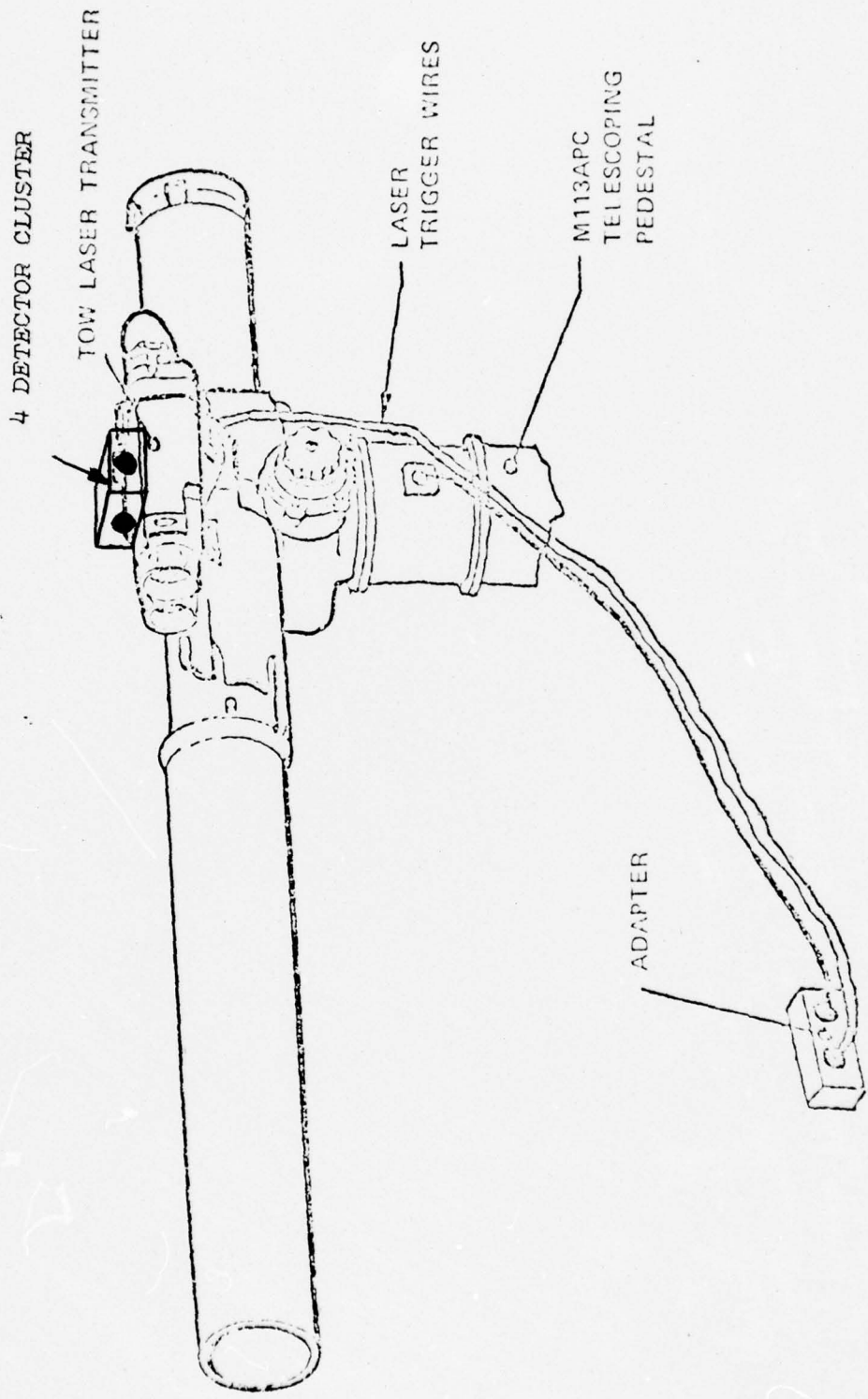
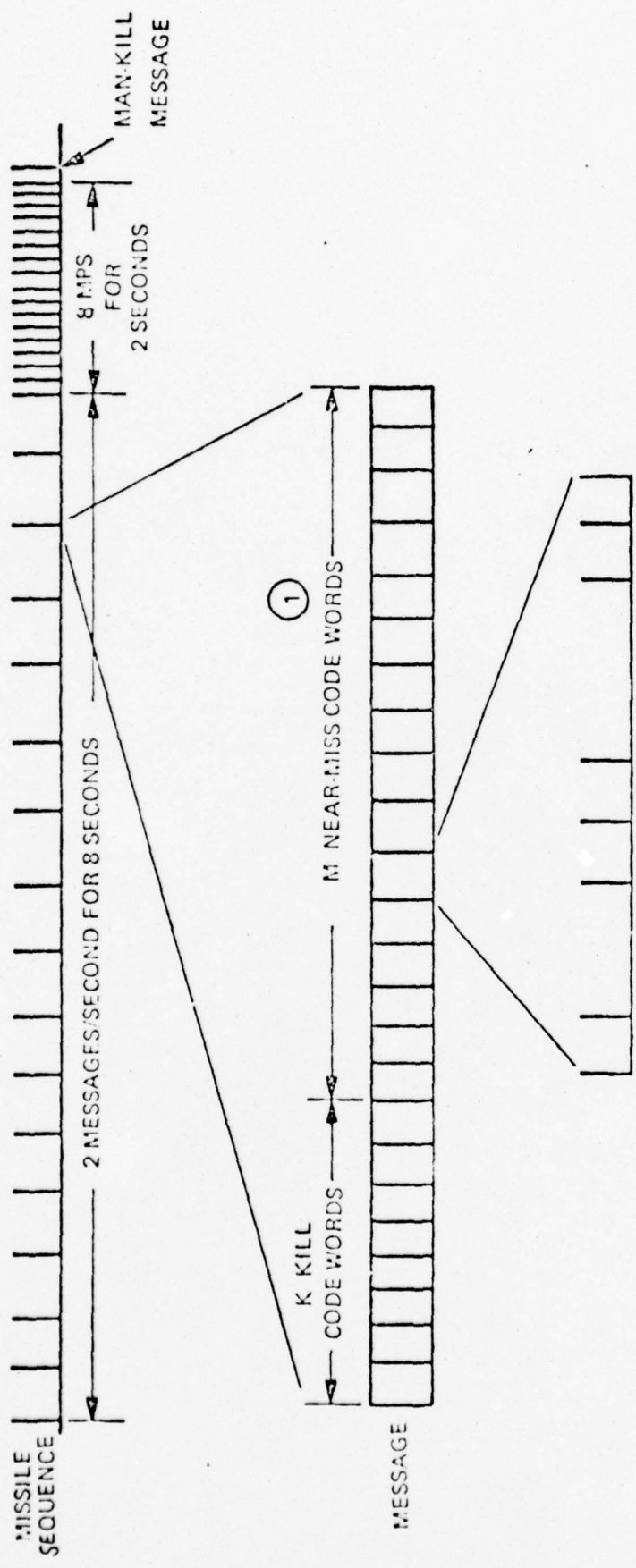

Figure 7. TOW Missile Laser Transmitter.

-The laser transmitter will be integrated into the TOW optical sight, with the laser factory boresighted to the TOW optical sight and the night sight rails.¹⁴ The laser operates in the near infrared portion of the frequency spectrum and has a range of 3,000 meters. The beam will be roughly 15 meters in diameter at that range. Unique laser codes identify the type weapon system the transmitter is simulating. The laser is automatically shut off when a kill occurs.

Figure 8 is the laser missile sequence as currently conceived for the TOW. The laser-on time is ten seconds for the missile sequence. Two messages per second are transmitted during the first eight seconds and eight messages per second for the last two seconds of the missile sequence. Each message contains eight words that cause the target vehicle to be "killed" and 16 words that cause the near miss tone on the target vehicle to be activated. For the TOW missile sequence, however, there is no near miss code (M=0).¹⁵

For a valid TOW engagement to occur, the laser must track the target for nine seconds. In those nine seconds 50 percent of the kill words must pair with the target for the first 7 seconds and 90 percent must pair for the last two seconds of simulated flight time. If the gunner tracks correctly for nine seconds a hit is assumed. The logic on the target vehicle then goes through a probability of kill routine to determine if a kill occurred. A .7 kill probability will be used assuming a successful nine second missile



WORD

① THERE IS NO NEAR-MISS CODE FOR MISSILES (m = 0)

Figure 8. Code Format.

tracking sequence. The probability that a successful tracking sequence will occur is .9.¹⁶

Because the gunner will have difficulty keeping the TOW on target for the first second of missile flight due to the initial blast of the TOW, the total tracking time required is nine of the 10 second laser-on time indicated in Figure 8.¹⁷

The capability will exist for the TOW laser transmitter to be set to fire with characteristics simulating a tank. This will allow APC TOWs to act the role of enemy tanks when tanks are not available for training.

Unlike the CDEC DFS, MILES is not capable of adjusting missile flight times as a function of range. As a compromise measure a 10 second missile flight time is assumed. The TOW missile travels 2,000m in 10 seconds. While this penalizes the gunner by requiring him to track longer at ranges less than 2,000m, it gives him an advantage at ranges greater than 2,000m. The required laser track time for a valid engagement will be adjusted based on data obtained during MILES Operational Tests II (OTII) to be conducted May 1978.¹⁸

-The detector subsystem is shown in Figure 6. It consists of sufficient detectors to insure all around coverage. Like the CDEC DFS, the MILES detectors sense the impacting laser energy and change the laser message to an electrical message that is transferred by cable to the decoder electronics.¹⁹ Detectors are also mounted on the TOW itself in a cluster on top of the sight to allow pairings when the M-113

APC TOW is in hull defilade. (The vehicle is hidden behind a mound of dirt and only the TOW on top of the APC is exposed.) If only the detectors mounted on the TOW are illuminated, the kill probability is reduced by a factor of 2 to compensate for the fact that the vehicle is in hull defilade.²⁰

-The decoder electronics is the "brain" of the system where all system logical functions are performed. Functions such as determining kills or misses, deactivating/activating the laser transmitter, activating the kill and near miss alarms, determining the reload time, laser timing, and power distribution are all functions performed by the decoder electronics.²¹

-Figure 9 is the loader control assembly panel. The panel is used with the M-60 A1/A2/A3 in addition to the TOW, hence the options for determining main gun and coaxial machine-gun "rounds remaining." For the TOW, only the missile "rounds remaining" option would be used. TOW "rounds remaining" can be read from the panel display by pressing the "rounds remaining" button. The "missile not ready to fire" light would stay on for duration of the laser "on" time plus the average time required to reload. Average TOW reload times used in CDEC experiments were 15 seconds, and that time will be assumed for MILES. The "missile not ready to fire" light, when lit, would not permit an additional simulated TOW round to be fired until the laser-on time plus the reload time has elapsed.²²

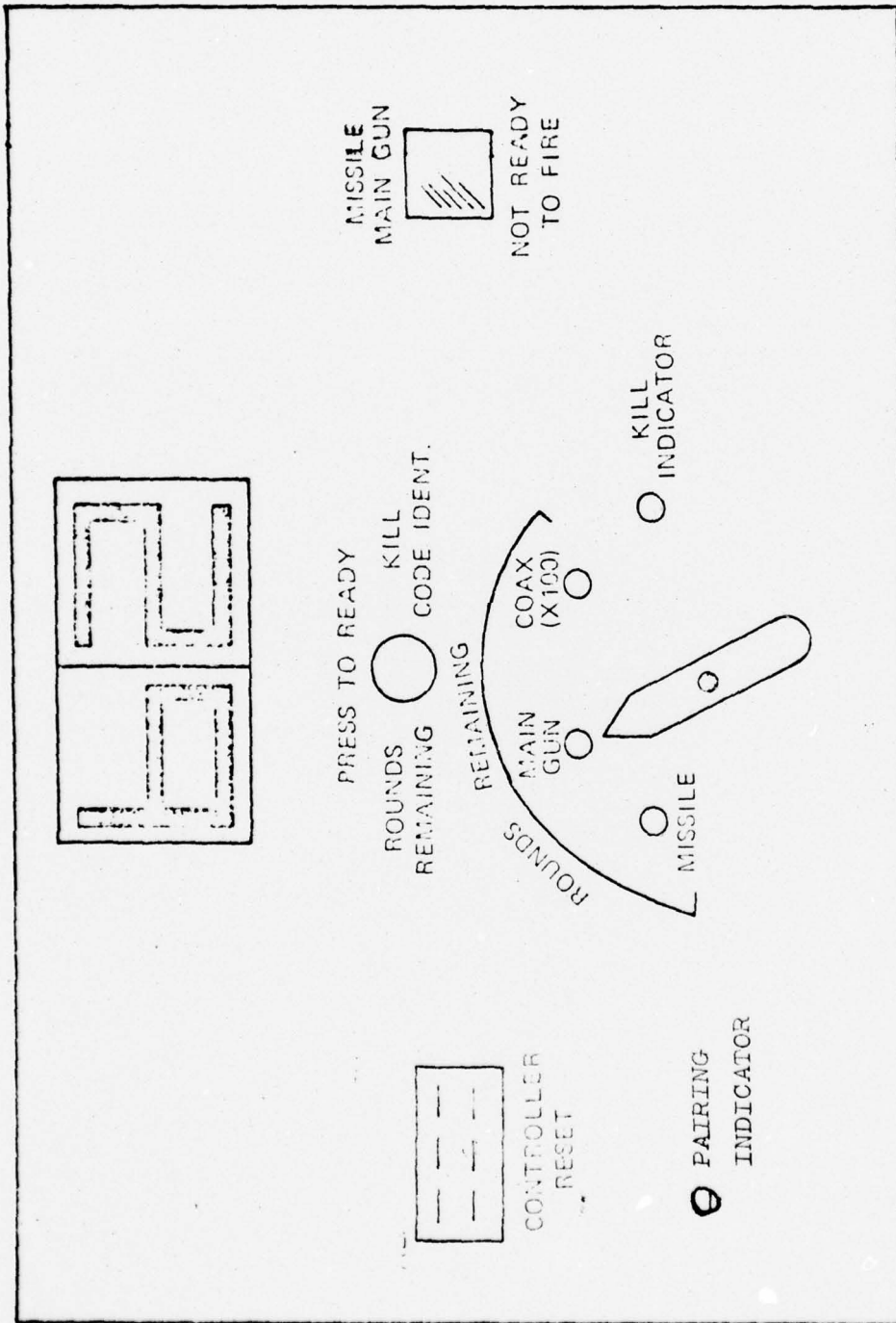

Figure 9. Loader Control Assembly Front Panel.

The kill indicator light goes on when the TOW system has been "killed" by another laser. System logic decodes the laser identification of the firing system to determine if the firing system is capable of killing the target vehicle, e . . , an M-16 cannot kill a tank, but it can kill the tank commander. Identification of the code of the laser transmitter that killed the TOW can be obtained by pressing the "kill code identification" button.²³ The "pairing indicator" light along with an intermittent alarm horn on the kill indicator assembly are activated when the system is paired by a laser in the "continuous fire" mode.

-The kill indicator assembly contains the hit alarm horn that produces a continuous tone for one minute when the system is killed, a one-second tone when a near miss occurs, and an intermittent tone when paired by a laser in the "continuous fire" mode. Additionally, a smoke grenade assembly is used to hold a smoke grenade that is activated when the system is killed.²⁴

-Controller keys are provided for controllers to activate the systems after they have been killed. Activation enables the laser to fire and gives the system its full load of ammunition (See Table 1).²⁵

-The M2 .50 caliber machinegun mounted on the M-113 APC with TOW has a laser transmitter mounted on it; however, it can only engage personnel equipped with the MILES infantry harness (See Figure 1).

The M-60 A1/A3 tank MILES is shown in Figure 10. The system is similar to the M-113 APC TOW.

-The laser transmitter is mounted in the gun chamber. A rifle scope factory aligned to the laser transmitter is used to assist in boresighting.²⁶ On firing, only one laser message is transmitted (See Figure 8) in approximately one second. This approximates the time required for a tank round to travel 1,500 meters for the Soviet T-62 tank and for the M-60 A1/A3 when improved ammunition is available.²⁷ The probability that a kill word will reach a target vehicle at a given range parallels the tank's probability of kill characteristics, e.g., an M-60 tank at a range of 1,500m will kill a target 50 percent of the time; similarly, at that range, a MILES kill word will reach a target 50 percent of the time and cause the target to be "killed."²⁸

-Reload time for the M-60 tank is 5 seconds.²⁹

-Laser transmitters are mounted on the 7.62mm coaxially mounted machineguns and the M-85 machinegun. These machineguns are only effective against personnel equipped with the infantry MILES. TOW and tank crew members would wear the infantry MILES.³⁰

-Boresighting of the M-60 main gun transmitter would be accomplished in a manner similar to that of the CDEC DFS. A special "continuous fire key" would place the laser in the continuous fire mode for boresighting. In this mode the laser stays on for duration of trigger pull.

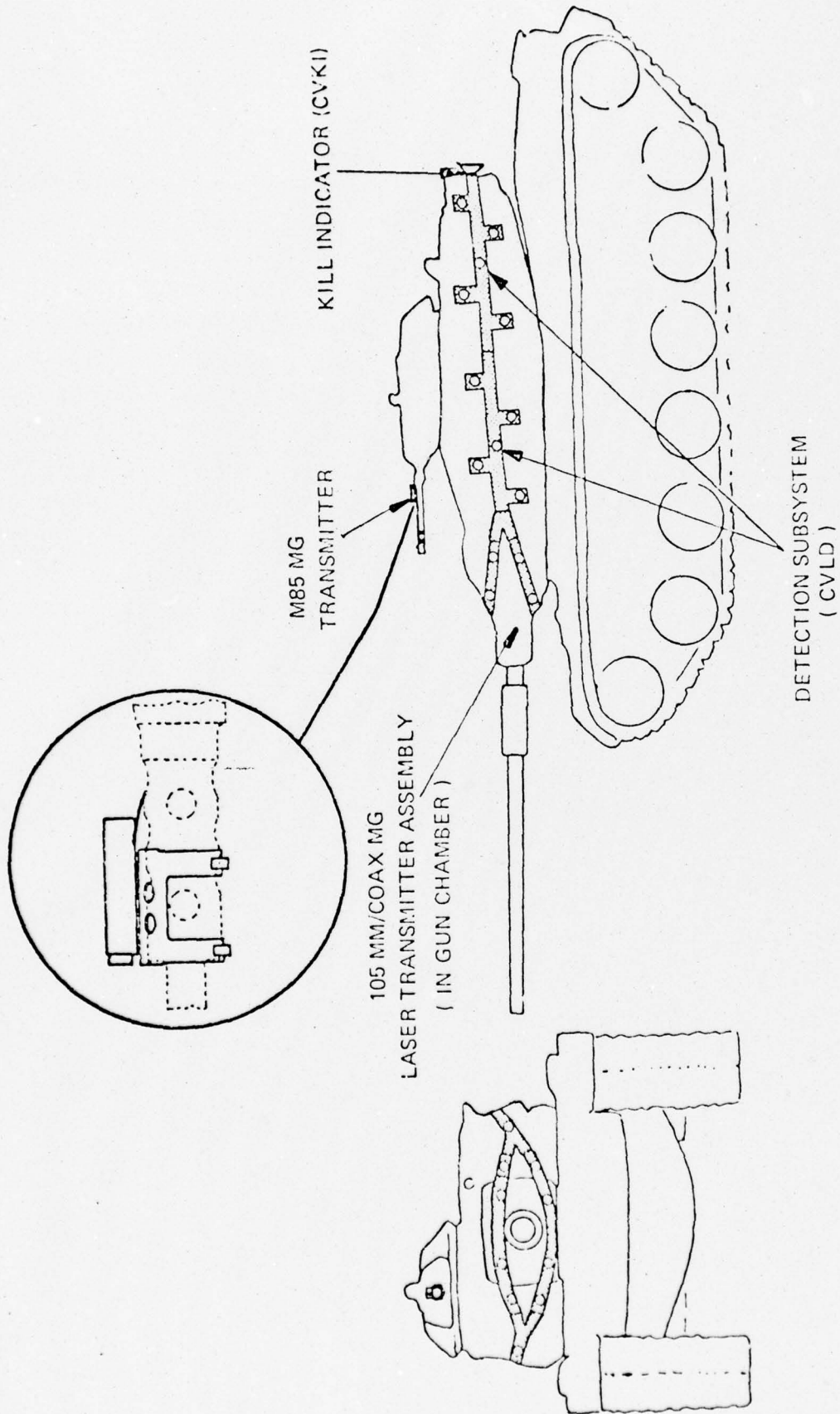

NOTE: THE TANK COMMANDER AND LOADER WEAR MWLDS.

Figure 10. M60A1/A3 Tank System.

-With the M-60 tank near misses are possible. The four kill words are transmitted before the 32 near miss words (See Figure 8), and it is assumed that the kill words will impact at the gunners point of aim. Jitter from the M-60 blast simulator (signature device) will cause "near miss" words to be distributed in a circular fashion around the point of aim. Therefore, if a kill word does not pair with a target a near miss word probably will, causing the near miss audio tone to activate. This provides a degree of suppression in the system.³¹

-Figure 11 is a drawing of the controller gun. It is used by controllers to kill players or "activate" dead players (bring back to life by allowing laser to fire and giving back the full basic load of ammunition). Special laser codes assigned for controller guns enable the remote kill and activation by controllers using the guns.³²

-Special signature devices will be available for the TOW and M-60 tank by the early 1980's to use on the weapons systems in conjunction with MILES. A signature device is one which simulates the blast effects produced when a weapon is fired. The Training Devices Agency at Fort Eustis, Virginia has issued a training device requirement (TDR) for a signature device for the TOW. The device will be called an antitank weapons effects simulator and will be available by the early 1980's. The signature device for the M-60 tank will be an adaptation of the German Hoffman Device. The Hoffman Device

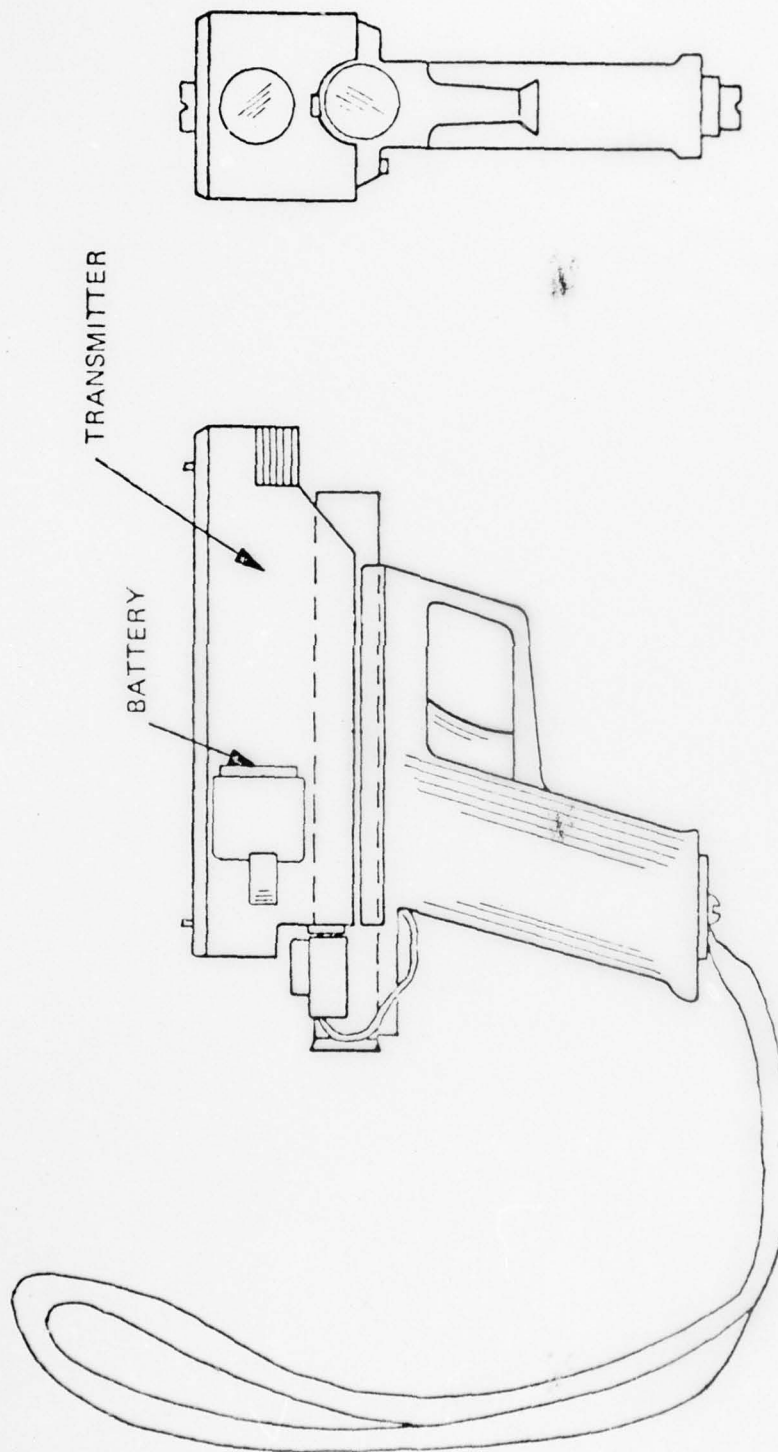

Figure 11. Controller Gun.

mounts in front of the tank searchlight at the turret end of the gun tube. The device is rectangular in shape with nine cylindrical tubes which hold the cartridges used to simulate the M-60 tank signature. When the gunner presses the trigger, one cartridge goes off. This device should be available throughout the Army by late 1977-early 1978. Blank rounds will be available for the various machineguns mounted on the TOW and M-60 tank.³³

SYSTEM LIMITATIONS

There is a degree of artificiality in the MILES TOW system simulation in that the illumination time required for a valid engagement cannot be varied as a function of range, but is set at 9 seconds, the time required for the missile to travel 2,000m. This artificiality is accepted as the best possible way of simulating the TOW system characteristics while still keeping system costs down.

The MILES is a tactical simulator, not a gunnery simulator. The laser transmitter is not used to simulate the round ballistics, instead it is used as a communicator to establish firer-target pairings. Kills are based on actual weapon kill probabilities at various ranges.

CHAPTER III

ENDNOTES

¹Larry J. Lam, Final Instrumentation Report for Experiment 23.1 (Fort Ord, CA.: BDM Scientific Support Laboratories, March 1973), p. D-2.

²Ibid., p. A-3.

³Richard U. Hunter, Final Instrumentation Report FC 021 HELLFIRE (Fort Ord, CA.: BDM Scientific Support Laboratories, May 1975), p. 21.

⁴Hunter, p. 21.

⁵Ibid., p. 22.

⁶George Roper, Final Instrumentation Report for Experiment 43.6 (Fort Ord, CA.: BDM Scientific Support Laboratories, 1972).

⁷Ibid.

⁸Ibid.

⁹Design Review Conference. Multiple Integrated Laser Engagement System. Electro-Optical Systems, XEROX Corporation, Pasadena, California, 23 September 1976.

¹⁰Statement by Major Larry Word on Multiple Integrated Laser Engagement System Characteristics, personal interview, Training and Doctrine Command, Training Support Center, Fort Eustis, Virginia, 16 November 1976.

¹¹MILES, Design Review Conference.

¹²Statement, Major Word.

¹³MILES, Design Review Conference.

¹⁴Statement, Major Word.

¹⁵MILES, Design Review Conference.

¹⁶Statement, Major Word.

¹⁷Ibid.

¹⁸Ibid.

¹⁹MILES, Design Review Conference.

²⁰TRADOC Bulletin #2, Soviet ATGMs: Capabilities and Countermeasures, U.S. Army Training and Doctrine Command, Fort Monroe, Virginia, April 1975, p. 12.

²¹MILES, Design Review Conference.

²²Ibid.

²³Ibid.

²⁴Ibid.

²⁵Ibid.

²⁶Ibid.

²⁷TRADOC Bulletin #1, Range and Lethality of U.S. and Soviet Antiarmor Weapons, U.S. Army Training and Doctrine Command, Fort Monroe, Virginia, 30 September 1975, p. 5.

²⁸Statement, Major Word.

²⁹TC 17-12-5, Tank Gunnery Training W/C1. Headquarters, Department of the Army, September 1975, p. 5.

³⁰MILES, Design Review Conference.

³¹Statement, Major Word.

³²MILES, Design Review Conference.

³³Statement, Major Word.

CHAPTER IV

FINDINGS (ANALYSIS AND EVALUATION)

OVERVIEW

Chapter III described the MILES as envisioned by the author as a first step in obtaining a solution to the stated problem. In this chapter facts which pertain to TOW crew training and tactical employment will be presented, analyzed and evaluated. Ways in which MILES can be used to quantify TOW measures of effectiveness will be discussed. Finally, current ARTEP standards as they apply to the TOW will be presented.

TOW SYSTEM DESCRIPTION AND TACTICAL EMPLOYMENT

-What are the technical characteristics of the M-113 APC mounted TOW?

"The TOW weapon system is a crew-portable and vehicle-mounted, heavy antitank weapon (HAW). It consists of a launcher, which has tracking and control capabilities, and the Tube-launched, Optically tracked, Wire-command link (TOW) guided missile which is encased in a launch container (See Figure 12).¹ The launcher is equipped with self-contained, replaceable units. The TOW weapon system can be employed in all weather conditions, as long as the gunner can see his

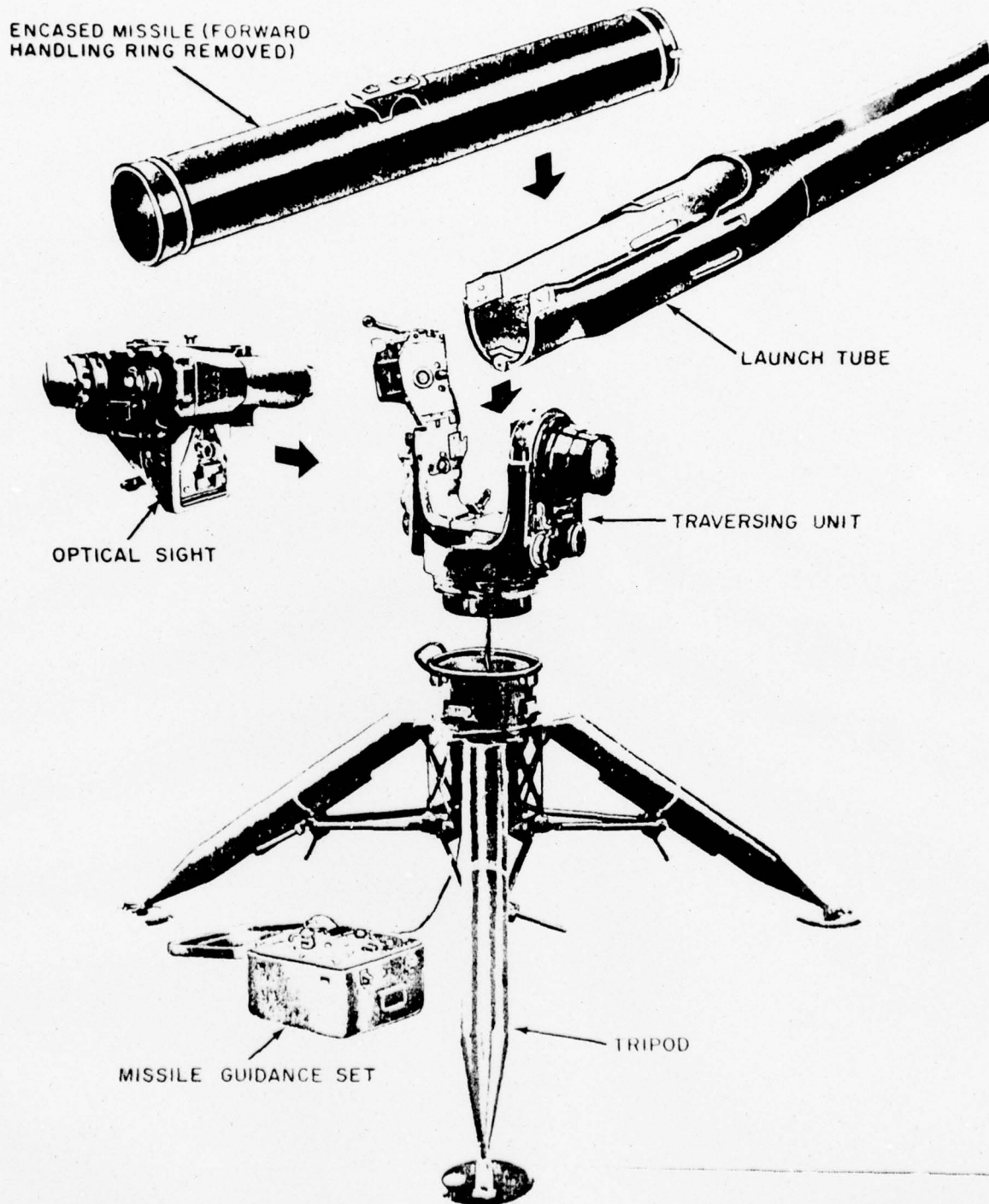

Figure 12. TOW Assembly.

target through the optical sight. The missile can be launched from a ground mount (tripod) or from a vehicle (See Figure 13).² The TOW is primarily an antitank weapon which provides long range engagement of all known armored targets. The TOW will also provide a long range assault capability against heavily fortified bunkers, pill boxes and gun emplacements.³

"To engage a target the TOW gunner acquires the target and tracks it by aligning the crosshairs of the optical sight with the target. When the target is within range, the TOW missile is launched. Deviations of the missile from the intended line of sight trajectory of the optical sight are sensed automatically by an infra-red (IR) sensor aligned with the optical sight (Figure 14).⁴ The IR sensor receives radiation from a coded IR source mounted in the aft end of the missile and produces error signals proportional to displacements of the missile from the intended trajectory. Flight correction commands are then transmitted over a wire command link to the missile. The missile maneuvers in response to these commands. Upon contact with the target, a shaped charge warhead is detonated."⁵

The following is general data pertaining to the TOW:

Minimum range - 65 meters

Maximum range - 3,000 meters

Ammunition - High explosive antitank (HEAT) missile

Crew - 4 man squad

Basic load - 10 missiles stored in racks of the APC TOW⁶

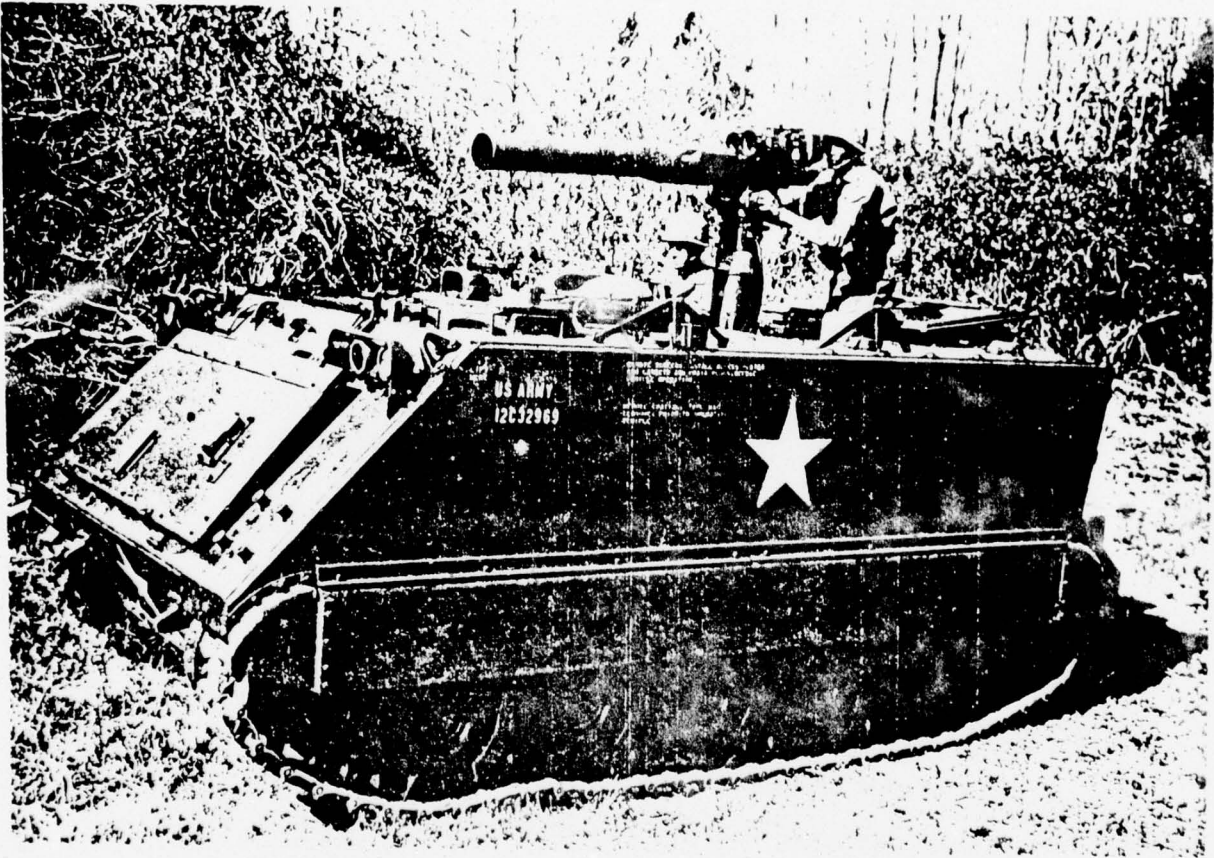

Figure 13. APC/TOW.

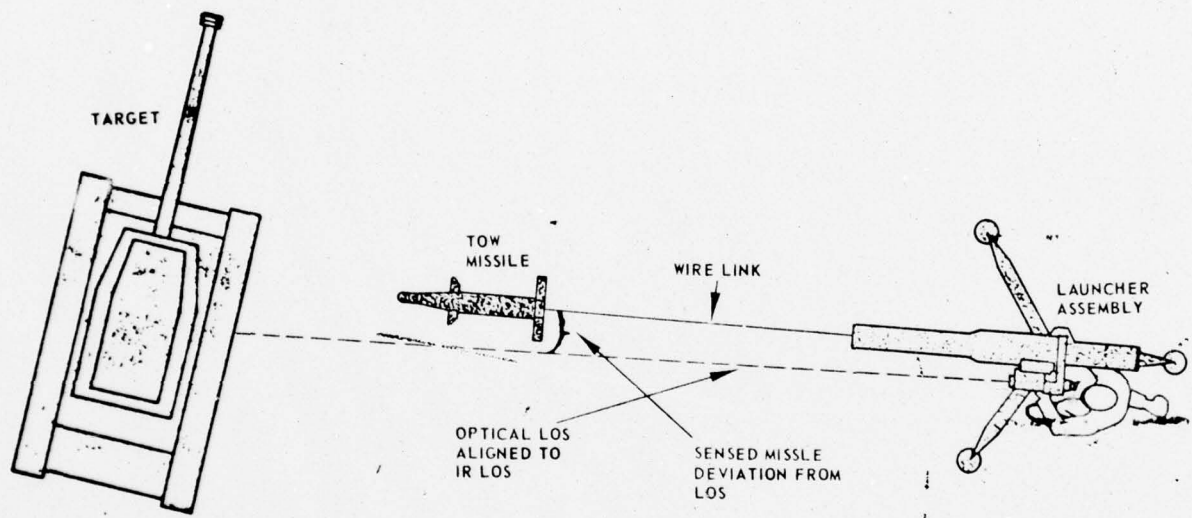

Figure 14. Target Engagement.

Hit probability - .9 at stationary targets (all ranges)⁷
Missile velocity - 200 meters per second (Average).⁸

Due to the high cost of the TOW missile, the M-70 training set was developed to train TOW gunners. "The training set consists of an instructor console, missile simulation round, and a target set (consisting of a power supply/modulator, target board, and an IR target source) (Figure 15)."⁹ The target board is mounted on an APC TOW which is used as a target vehicle. The IR source provides a line of sight reference between the launcher and the target.¹⁰ On a typical sequence, the gunner acquires the target and performs a simulated TOW firing. On firing, a blast simulator diaphragm in the missile simulation round ruptures and produces sound and blast effects similar to the TOW missile launch. Launcher/target tracking errors for the entire simulated missile flight are scored on the instructor's console. Maximum scores of 100 points are possible for each tracking run. However, a tracking run is invalid if an electromechanical flag appears on the instructor's console indicating ground impact or launch excursion. Ground impact indicates that the gunner tracked so low that the missile would have hit the ground. Launch excursion indicates that the gunner tracked so poorly during the first 2.6 seconds after launch that his chances of successfully guiding the missile to the target would be severely reduced. Launch excursion is caused by the gunner's failure to hold the TOW launcher steady during missile launch.¹¹

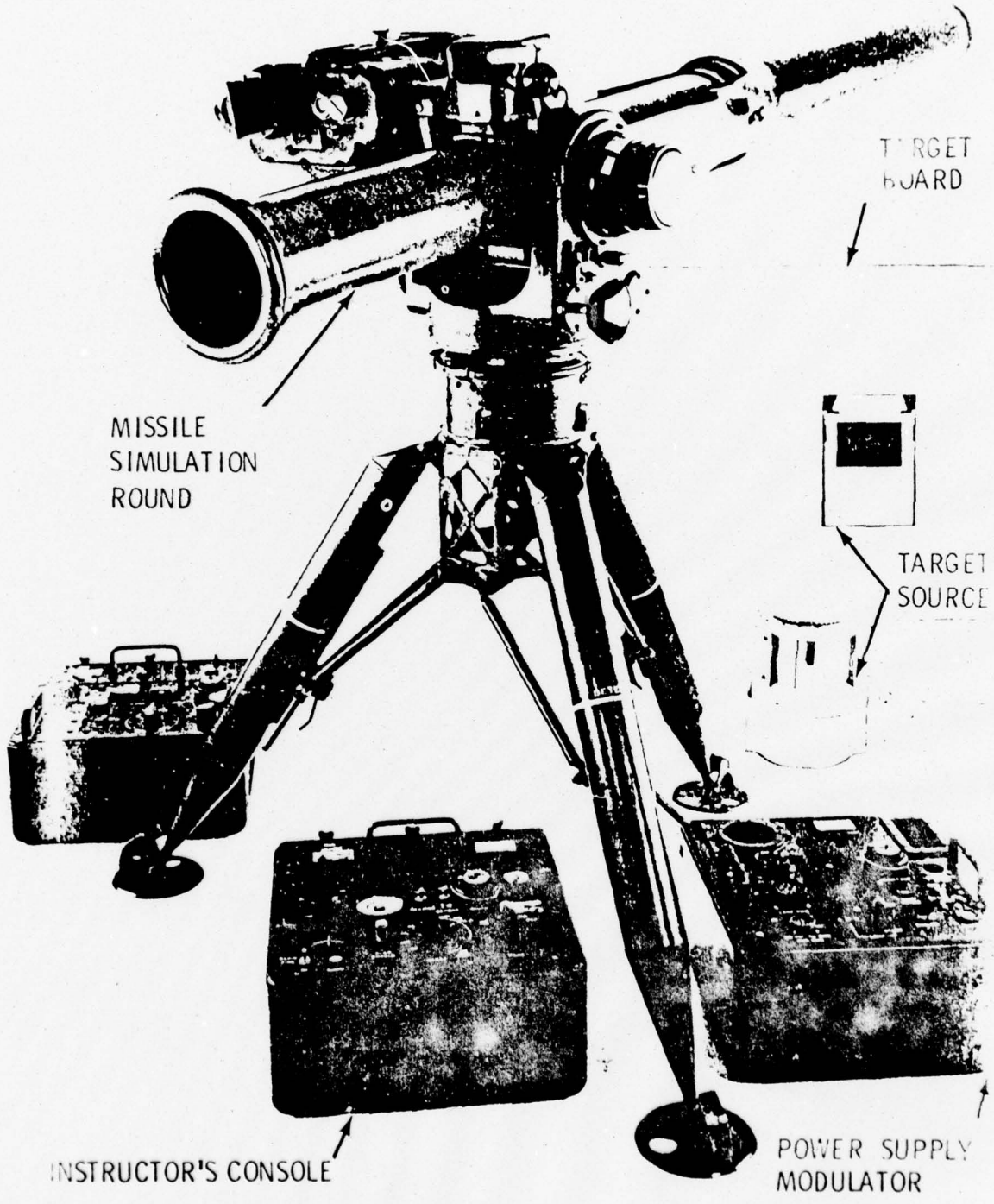

Figure 15. Guided Missile System Training Set XM70.

At the end of each simulated missile firing sequence an electric horn sounds a tone of 2 second duration.

"Qualification with the M-70 training set consists of evaluating gunner tracking performance for two qualification tracking time durations--medium seconds and long seconds. These times are measured from simulated missile launch motor ignition and are obtained by setting the instructor console RANGE switch to either the high rate qualify (medium seconds) or the low rate qualify (long seconds) position when operating in the qualify mode. Target engagements that involve intermediate tracking time duration of medium seconds are performed at target crossing rates of 15 and 25 milliradians/second (mr/sec). These conditions define qualification tasks B and C, respectively. Target engagements that involve the long tracking time duration of long seconds are performed at a target crossing rate of 5 mr/sec. This condition defines qualification task A."¹²

Table 2 shows the TOW qualification scoring table. Five qualification tracking runs are required for each task, and a ground impact or launch excursion flag invalidates a tracking run.¹³

Night tracking is not required for gunner qualification; although, familiarization night tracking of stationary and slow moving targets under illumination, is part of the TOW crew training. Additionally, after qualifying with the M-70 training set, familiarization live firing at stationary and

Table 2
Scoring Table

| CLASSIFICATION | TASK | TRACKING TIME DURATION | LINE-OF-SIGHT RATE, W (MILLIRADIANS SEC) | TOTAL SCORE BANDS | | | |
|----------------|------|------------------------|------------------------------------------|-------------------|------------------|-----------------|-------------|
| | | | | EXPERT | 1ST CLASS GUNNER | 2D CLASS GUNNER | UNQUALIFIED |
| LOW RATE | A | LONG | 5 | 375-449 | 325-374 | 275-324 | 0-274 |
| HIGH RATE | B | INTERMEDIATE | 15 | 450-500 | 413-449 | 375-412 | 0-374 |
| HIGH RATE | C | INTERMEDIATE | 25 | 375-449 | 325-374 | 275-324 | 0-274 |

moving targets are conducted when live missiles are available for training.¹⁴

There are three type of munitions used with the TOW. These are the conventional HEAT missile with a live warhead the practice guided missile with an inert warhead which is used for practice firing, and the blast simulator diaphragm used for training with the M-70 training set.¹⁵

When the TOW launcher firing trigger is pressed there is a 1.5 second delay before the missile is launched. The delay allows the missile gyro to build up speed and the thermal heating pads to heat and activate the missile batteries.¹⁶

The TOW backblast area consists of a conically shaped 90° danger zone and caution zone. The danger zone extends 50m back from the launcher. The caution zone extends an additional 25 meters back from the danger zone.¹⁷

If the missile fails to fire TOW misfire/hang fire procedures call for the gunner to continue tracking for one minute after attempting to fire. Several system checks are made and two more attempts to fire the missile are conducted. If the missile still does not fire, the crew waits for a 30 minute safety interval before removing the missile from the launch tube and calling explosive ordnance demolitions (EOD) personnel to dispose of the faulty missile.¹⁸

Although protective measures to be used in a chemical environment are not discussed in the TOW manual, the TOW crew must be able to preform effectively while wearing the M-18

protective mask and chemical warfare protective clothing. While wearing the protective mask, it is difficult to track with the TOW; because, the gunner has difficulty placing his eye on the TOW sight eyepiece.

If contaminated by chemical agents, the TOW is decontaminated using procedures specified in Chapter 11, TC 23-23.

-How is the TOW section tactically employed in the active defense?

The TOW section normally operates as part of the mechanized infantry company. It consists of two M-113 APCs with TOWs manned by 8 men. Personnel breakdown for the TOW section is as follows:¹⁹

Section Leader (SSG, E-6) - 1
 Squad Leader (SGT, E-5) - 1
 Gunner (SP/4, E-4) - 2
 Assistant Gunner (PFC, E-3) - 2
 APC Driver (SP/4, E-4) - 2

Note that the section leader is also the squad leader for one of the two TOWs in the section. The mechanized infantry company is often augmented by one or two additional TOW sections from the battalion's antitank platoon.

In addition to the TOWs, vehicles/weapons systems found in a mechanized infantry company include: 12 APC w/.50 cal machinegun and the M-47 Dragon antitank weapon, 3-81mm mortars mounted on APC's, light antitank weapons (LAW) issued to individuals as a round of ammunition as required by the situation, and 5-M-60 tanks (when augmented by a Tank platoon).²⁰

The TOW section/squad leader upon receipt of a defensive mission:

-Reconnoiters and selects the exact TOW firing positions (primary, alternate, supplementary) and routes into and out of the firing positions. Additionally, he supervises the preparation of the positions (primary and alternate positions allow firing into the most likely avenue of enemy tank approach into the defensive position; supplementary positions are oriented in directions other than those of the primary and alternate positions).

-Coordinates with adjacent antitank weapons to insure mutual support and integrates the security of the TOW crew with local units.

-Supervises the preparation of range cards and controls the fires of the section/squad.

-Controls the movement of the section/squad between primary, alternate, and supplementary positions.

-Requests and coordinates resupply of ammunition and other crew needs.²¹

-Insures that the M-113 and the TOW are properly maintained.

TOW squads should be employed in pairs (by section) to insure continuous coverage of a particular sector of fire. Additionally, the TOW squads should be separated by a minimum of 300m in width or in depth to insure that one artillery volley will not suppress both squads at the same time.

The most significant advantage of the TOW is that it is accurate at ranges beyond 1,500 out to 3,000m. This is an advantage in engaging enemy armor; since, the tank is accurate at ranges less than 1,500m. The major disadvantage of the TOW is that it is susceptible to enemy suppressive fires while the TOW crew is engaging a target.²² Therefore, in employing the TOW, it must be positioned in such a manner that it is able to engage targets at long ranges while protecting the crew from enemy fires.

TC 7-24, Antiarmor Tactics and Techniques for Mechanized Infantry lists the following general principles for positioning the TOW:

- "Always use terrain to your maximum advantage.
- Position TOW to exploit its accuracy out to 3,000 meters.
- Use natural cover and concealment.
- Avoid conspicuous terrain features.
- Employ TOWs so that they are mutually supporting.
- Integrate TOW with nearby infantry for security.
- Position TOWs to engage the enemy from the flank."²³

In preparing TOW positions, whenever possible, the APC TOW should be dug-in so that it is in hull defilade. The probability of the TOW being hit drops by at least one-half when in hull defilade.²⁴ The TOW can also be dismounted from the APC and employed in a fighting position with overhead cover. When natural concealment does not exist at the firing

location, the TOW is positioned at a nearby covered and concealed position called a "hide position." A squad member with binoculars remains at the firing location as an observer. When a target is detected by the observer, the TOW is called forward to engage the target.²⁵

In order to successfully engage a target, the TOW crew must acquire and identify the target, determine if it is within range, and engage the target. "When engaging targets, gunners should insure that they will be able to track the target until missile impact; otherwise, missiles will be wasted. Missile flight time must be considered (6 seconds 1,000m, 11 sec 2,000m, 17 sec, 3,000m). A good rule of thumb is to always assume 'worst case' conditions. Gunners should always consider that the threat vehicle is moving at top speed--approximately 10 m/s (22.5 mi/hr). Considering an average velocity of 200 m/s, at 2,500m it will take the missile $12\frac{1}{2}$ or 13 seconds (round up) to reach a target. A target must be exposed at least that long to be hit. It is particularly important that TOW squads in preparing range cards, include such data as distances between covered areas in their sector and the ranges to those areas."²⁶

Methods used to control TOW fire include designation of:

-Sectors of fire--that terrain which the TOW section/squad is to cover with their fire.

-Target reference point (TRP)--Easily identifiable terrain features within TOW range which can be used as a

reference to identify targets.

-Patterns of fire--established patterns which can be used to engage enemy targets, such as:

FRONTAL- each TOW engages from the flanks to center

CROSS-TOWs cross and engage from the far flank to the center.

DEPTH--one TOW starts with the nearest target and works its way out in range; the other TOW starts deep and works its way in.

-Firing sequence--TOWs can fire "at will" (whenever they are ready) or staggered (one after the other).

-Engagement priorities--priorities of engagement of enemy vehicles by type, such as: tanks, BRDM, ZSU -23, SAGGERS.

-Fire commands--are standardized to minimize radio transmission time and speed target engagements. It includes:

ALERT: "TIGER TWO, this is TIGER ONE, FIRE MISSION"

TARGET DESCRIPTION AND LOCATION: "Five tanks, 500 meters east of TRP ALPHA"

FIRE CONTROL METHOD: "CROSS"

EXECUTION: "FIRE"

If communication is lost, TOWs automatically fire their sectors of fire.

-Emergency signals--if radio communication is lost, units using their own SOP (standard operating procedures) can use emergency signals such as pyrotechnics to control fires.²⁷

"As soon as possible after occupation of a firing position, the TOW section leader prepares a firing list and forwards it to his commander. The list includes location of firing positions and the TRPs covered both during the day and at night."²⁸

Range cards are always prepared when time permits in the active defense for each firing position. The range cards are used by the gunner as a reference and facilitates using the weapon at night. The range card is a sketch of the sector of fire and as a minimum includes the following:

- Preparing unit and date.
- Sector of fire.
- Maximum range line.
- Deadspace.
- The weapons position - plotted with range and azimuth from a known point.
- TRPs both within range of weapon and beyond its range but within sight (includes ranges to TRPs and other prominent terrain features).
- Covered areas and distances between covered areas (intervisibility segments).²⁹

"The advent of long-range, highly effective night sights for the TOW permit it to be used during periods of reduced visibility in the same way as in daylight. However, due to the short life of the batteries and gas bottles associated with the night sight, it cannot be used as a

surveillance device. Targets must be acquired using other night observation means; once acquired, the gunner can look with the night sight and engage the target.

"Squad leaders should be proficient in procedure to adjust illumination fires at night, and also adjust HE fire into areas in which the TOWs cannot fire (deadspace, woods, etc.)

"It may be necessary to displace to new firing positions at night, in order to provide continuous coverage of the sector(s) of fire. When analyzing terrain for firing positions, section/squad leaders must consider and find locations that can cover the sector of fire at night, if the day position is not adequate (due to reduced visibility)."³⁰

TOWs can also be employed from buildings in build-up areas. Special care must be taken due to the backblast of the TOW.³¹

An additional skill which must be acquired by the TOW squad is the ability to recognize threat armor/antitank weapons systems.

THREAT TACTICS AND EQUIPMENT

-What are the threat tactics and equipment most likely to be encountered in a European environment?

The most serious threat to United States and NATO forces in Europe are the Soviet/Warsaw Pact nations. In considering how the APC TOW will be employed in the active defense in Europe, it is necessary to examine Soviet/Warsaw

Pact offensive tactics to determine the size and composition of the force expected to be encountered.

There are three Soviet offensive operations. These are the hasty attack, deliberate attack and pursuit. The hasty attack is conducted from the march and is designed to quickly overcome or to fix and bypass enemy positions. The pursuit normally follows the breakthrough and is characterized by rapid movement to destroy fleeing enemy forces. The breakthrough is the Soviet deliberate attack designed to penetrate enemy defenses in the main battle area.³² Of the three types of offensive operations the breakthrough is the most dangerous to defending forces and will be discussed in detail.

The Soviets will normally attempt to achieve their breakthrough using motorized divisions. These lead divisions will be followed by tank divisions which will exploit through the breakthrough area and penetrate deep into the defenders rear area.³³

A defending U.S. mechanized infantry company can initially expect to encounter one or two Soviet motorized battalions. This assumes a frontage of 1,500-2,500 meters for the U.S. mechanized company. Figure 16 shows a typical motorized battalion attack formation.³⁴ In effecting the breakthrough, the motorized battalion will mass from a 3 kilometer front to a 1.5 Km front.

It is expected that the motorized battalion will attack as part of a motorized regiment; therefore, two

MOTORIZED RIFLE BN IN THE ATTACK

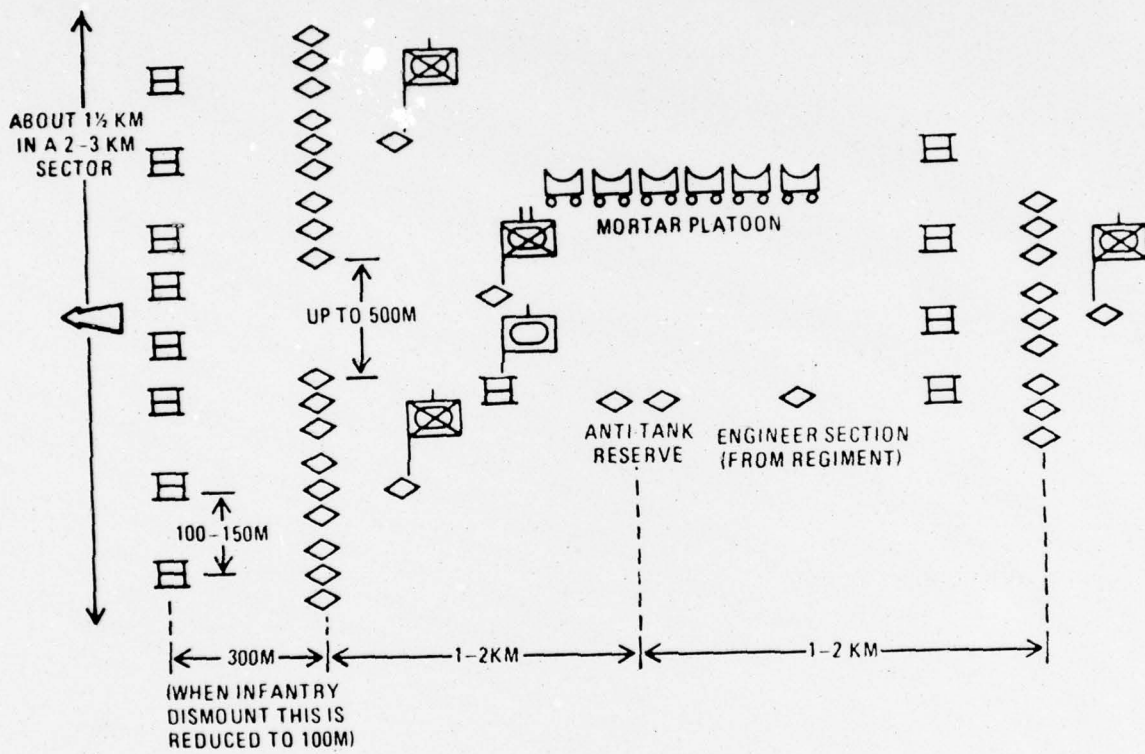

Figure 16. Motorized Rifle Battalion in the Attack.

adjacent motorized battalions can be expected to affect the breakthrough on a 3 Km front, (about 1.5 Km per Bn). A second echelon motorized battalion will follow the lead battalions at a distance of 3-6 Km to reinforce, bypass, mop-up or continue the momentum of the attack.³⁵

Antitank weapons (100mm guns, SAGGER and SWATTER MISSILES) will be in camouflaged positions to the flanks, behind, or in the gaps between the companies. It should be noted that all BMP's (Soviet APC) are equipped with launch rails for the SAGGER antitank missiles. Additionally, the BMP has a turret mounted 73mm gun capable attacking medium tanks to ranges of 1,000m.³⁶ Anti-aircraft weapons such as the ZSU-23 can be expected to be interspersed within the formation.³⁷

The breakthrough will be preceded by a 15-30 minute artillery preparation. For the breakthrough, Soviet artillery will be employed in densities of 70-100 tubes per kilometer.³⁸ Heavy use will be made of smoke, and the artillery fires will not be lifted until the Soviets cross their attack line which is roughly 200 meters from the defenders positions.³⁹ Soviet tanks will be employed in platoons of three tanks. "The Soviet tank platoon techniques of fire is for the tank platoon leader to direct the fire of his entire platoon on one target, then after the kill, the fire is shifted to another target."⁴⁰

The breakthrough will be preceded by a thorough reconnaissance with emphasis on locating the defenders tank

and antitank positions. Engineers will clear obstacles ahead of time, if possible.⁴¹

"The Soviets prefer night operations when terrain and obstacles eliminate the possibility of surprise and will cause excessive losses in daytime operations. Round-the-clock operations are habitual to maintain the uninterrupted momentum of the offense. Soviet units are well trained in night operations.

"Soviet units are also equipped with devices to aid in night fighting, including gunlaying telescopes, night viewers, night driving, and aiming equipment, and sniperscopes. Battlefield illumination is used frequently at night and during periods of reduced visibility."⁴²

Table 3 shows a listing of selected Soviet antitank weapons and their effective ranges.⁴³

Table 3

Soviet Antitank Weapons

| USSR WEAPON | EFFECTIVE RANGE (METERS) |
|----------------------|--------------------------|
| T-62 TANK | 1,500 |
| SWATTER MISSILE | 2,500 - 3,500 |
| SAGGER | 3,000 |
| RPG-7 | 300 |
| 100MM AT GUN (TOWED) | 1,000 |

The TOW section with the TOWs 300-500m apart is capable of engaging targets 3,000m in depth toward the enemy on a front of roughly 3,000-6,000m. Therefore, given inter-visibility, any vehicle on that front is a target for the TOW.

Typically two Soviet battalions attempting to breakthrough on a 3 Km front would consist of 26 tanks, 72 BMP (some with AT missiles) and 6-100mm AT guns or roughly 104 vehicles/weapons. A mechanized company team defending against the breakthrough would be composed of 5 tanks. Eight APC each carrying DRAGON (1,000m range), and 6 APC w/TOW or roughly 19 vehicles.⁴⁴

Assuming that the threat vehicles can be seen out to a range of 3,000m and are traveling at a speed of 5 m/s (11 mi/hr), then each friendly weapons system must service at least 5.5 enemy vehicles/weapons in 10 minutes for the defense to be successful. Additionally, the defending company must be prepared to engage the 2d echelon battalion of the first echelon regiments or an additional 31 BMP and 14 tanks or 45 vehicles. If the 2d echelon regiment is committed, then the mechanized company must service an additional 40 tanks, 93 BMP and 6-100mm AT guns or 139 vehicles/weapons system. This implies that the defending company within roughly a 24 hour period could be opposed by 288 vehicles/weapons systems, and that each defending weapon would have to service 15 enemy weapons systems, assuming no casualties on the defending side.

"Due to their heavy losses in gas casualties (475,000) during World War I, the Soviets consider the use of chemical weapons as an integral part of future tactical warfare."⁴⁵ It can reasonably be expected that the defending TOW section must be prepared to fight in a chemical warfare environment.

TOW MEASURES OF EFFECTIVENESS AND MILES

-What are the measures of effectiveness of the M-113 APC mounted TOW in antitank battle?

Based on the preceding discussion there are a number of things which a TOW squad/section must be able to accomplish in order to be successful in battle. On a very basic level the TOW crew must be able to accomplish the following tasks:

- a. Prepare the weapon for firing.
- b. Know the extent of the TOW backblast area.
- c. Know the TOW misfire procedures.
- d. Track both stationary and moving targets out to ranges of 3,000m with moving targets traveling from 10 mph to 35-56 mph.
- e. Track at night using the TOW night sight.
- f. In a chemical warfare environment with chemical protective equipment on, track effectively both day and night.
- g. Track successfully while being suppressed by artillery and smoke.
- h. Perform operator maintenance on the TOW and M-113 APC.

At an intermediate level the TOW squad/section must be able to accomplish the following tasks:

- a. Reconnoiter and select exact firing positions and routes to the firing positions.
- b. Prepare the firing positions.
- c. Insure mutual support within the section and with adjacent antitank weapons.
- d. Integrate the security of the TOW crew with the local units.
- e. Prepare range cards and target lists.
- f. Control fires to insure efficient engagement of targets.
- g. Move quickly between primary, alternate and supplementary positions as required by the tactical situation.
- h. Adjust mortar and artillery fires to include illumination.
- i. Using the TOW night sight, engage targets at night as effectively as during the day.
- j. If contaminated by a chemical agent, decontaminate the TOW and M-113 APC.
- k. Request and coordinate resupply of ammunition.
- l. Identify Soviet tanks and antitank weapon systems.

Once the TOW crew has mastered the basic and intermediate tasks, teamwork and battlefield know-how must be developed within the TOW section. In order to further define the TOW measures of effectiveness, data derived from field

tests and computer modeling must be examined.

In 1973 the Tactical Effectiveness of Antitank Guided Missiles experiment was conducted at the Army Combat Developments Experimentation Command (CDEC) in California. This experiment was conducted to gather data on the effectiveness and vulnerability of antitank missile systems to include the APC TOW. Sophisticated photographic, computer, and voice recording systems were used to collect data. A number of live firings were conducted at stationary and moving vehicles with overwatching tanks attempting to detect and pinpoint (with the tank main gun sight) the firing TOW. In addition for part of the experiment a two-sided real-time casualty assessment exercise was conducted using the laser Direct Fire Simulator (DFS) and the position location/telemetry system described in Chapter III. All data collected during the experiment was time-tagged to a common time base for correlation of data collected using the various instrumentation systems.

For the two-sided trials the force mix was as follows:⁴⁶

FRIENDLY:

APC TOW - 2
M-551 SHILLELAGH - 1-2
DRAGONS - 2

THREAT:

T62 TANK - 7-9
ATGM (SAGGER 2-3
BMP (TROOP CARRIER) 1-2 (could not fire)

The average speed for threat vehicles when the "rapid approach" tactics was used was 11 mph (5 m/s).⁴⁷ The rapid approach

emphasizes the use of speed by the threat to breakthrough the defending forces. During the rapid approach trials, the tanks were stationary 23 percent of the time--the ATGM's 33 percent of the time.⁴⁸ Threat armor elements first came into view of the antitank missile systems (ATM) at an average range of 2,831m with the first armored element engaged by TOW at an average range of 2,367m.⁴⁹

The following is a summary of pertinent TETAM data:

-The median delay time between initiation of line-of-sight (LOS) and detection of a threat vehicle was 20 seconds at ranges out to 4 km with little variation as a function of range.⁵⁰

-The median time from detection of a threat vehicle by the TOW to engagement was 8 seconds.⁵¹ If the maximum TOW missile flight time is considered (17 sec), then the median time for an engagement from initiation of LOS to missile impact is 45 seconds.

-The threat crews detected the ATMs about once for enemy three firings and were extremely accurate in pinpointing (laying-in the gun sight on the ATM) the detected weapons. The median times from detection of an ATM system to pinpoint varied from 10-15 seconds.⁵²

-During live missile firings, random sightings accounted for the largest percentage of the detection cues (77 percent) of the firing ATM position.⁵³

-When moving from a "hide" position to a firing position and back to the hide position, the exposure time for

the TOW was found to be 23 seconds exclusive of missile flight time. Movement and launch signatures were the predominant detection clues. This data is summarized below:⁵⁴

| <u>DEFILADE TO FIRING POS</u> - 5.5 SEC | <u>DETECTION CUE</u> | <u>PERCENTAGE</u> |
|------------------------------------------|---------------------------------------|-------------------|
| PREPARE TO LAUNCH - 8.5 SEC | MOVEMENT | 53* |
| FIRING POS TO DEFILADE - 9.0 SEC | LAUNCH SIGNATURE | 67* |
| MAX MISSILE FLIGHT TIME- <u>17.0 SEC</u> | RANDOM SIGHTING | 8 |
| MAX TOTAL EXPOSURE TIME-40.0 SEC | *MULTIPLE CUES WERE REPORTED AT TIMES | |

-In the two-sided trials the mean time between engagements for the TOW was 83 seconds. "An average of 5.7 targets were simultaneous intervisible with an ATM system at the time of engagement by an ATM."⁵⁵

-On the average the loss exchange ratio was 5-1 favoring the Blue forces (defending ATM) over the attacking Red forces. The TOWs normally attrited 32 percent of the Red force (3.4 T-62, .7 ATGM). Overall the Blue force attrited 50 percent of the Reds; while the Red force attrited 25 percent of the defenders.⁵⁶

At CDEC site A (the more open of the two sites used), 80 percent of the TOW engagements and kills occurred at ranges from 1,500m - 2,500m with T-62s scoring only .7 kills per battle. This occurred because most T-62s were killed early in the battle. At CDEC site B, 85 percent of the TOW engagements and kills occurred at ranges from 500m - 1,500m with T-62s scoring 1.5 kills per battle.⁵⁷

-On the average it took two TOW rounds to achieve a kill.⁵⁸

-When the Red forces used the rapid approach technique, there were 11 Red losses for each Blue loss. When they used the fire and movement technique, the loss exchange ratio decreased significantly.⁵⁹

-Limited night trials were conducted which generally showed the TOWs to be effective at night. Detailed data remains classified.⁶⁰

-Data from the two-sided trials was used in a post-play computer model to determine the effects of artillery on ATM performance. With the threat using the rapid approach technique, three times as many tanks reached the objective (35 percent vs. 13 percent) when the defenders were suppressed by artillery fires.⁶¹

In preparation for the Antiarmor Systems Program Review hosted by the Combined Arms Center, Fort Leavenworth, Kansas, in April 1976, the U.S. Army Combined Arms Combat Developments Activity conducted an analysis using their Battalion Level Differential Model (BLDM). BLDM was used to determine the optimum number of TOWs required in a mechanized infantry/tank company in order to succeed in a European scenario.

The specific BLDM scenario has a Blue mech/tank company team defending in the main battle area in the Fulda Gap, FRG. The 1976 base mechanized infantry company team consisted of:

- 5 - M60A1 Tanks
- 8 - M-113 APC w/DRAGONS and .50 cal machinegun
- 4 - M-113 APC TOW

The 1976 base tank company team consisted of:

- 12 - M60A1 Tanks
- 4 - M-113 APC w/DRAGONS and .50 cal machinegun
- 2 - M-113 APC TOW

Two different threat forces were used against each type of the defending companies. The two threats consisted of two reinforced tank battalions and two reinforced motorized rifle battalions.

The tank threat consisted of:

- 62 - T-62 tanks
- 20 - BMPs (each capable of firing 1 SAGGER)
- 9 - BRDMs (6-SAGGER each)
- 2 - SA9 (Air Defense only)
- 2 - ZSU-23-4 (Air defense primarily but can be used against ground vehicles)

The motorized threat consisted of:

- 20 - T-62 tanks
- 60 - BMPs
- 9 - BRDM
- 2 - SA9
- 2 - ZSU-23-4⁶²

The threat advanced on three axis until they were about 1,000m from the defenders. They then massed and

attacked on a 1,800m front. The defending company occupied a 2,000m front.⁶³

The defenders were in hull defilade positions in a static defensive posture. The SAGGER on the BMP was treated as a self-defense weapon, and while the BMP has a basic load of four SAGGERS, each BMP was allowed to fire only one SAGGER during the attack. The 73mm gun on the BMP was used when within range (1,000m). The BRDM with SAGGER is considered the prime antitank missile weapons system and was used in an overwatch mode behind the attacking companies.⁶⁴

The SA9 was employed solely for air defense; while the ZSU-23-4 was allowed to fire at ground targets when there was no air threat to the attacking forces.⁶⁵

Some findings of the study are as follows:

- "The anticipated threat cannot be defeated by the company team using a static defense with current organizations and weapons systems. This is true even assuming a battlefield that allows some detections out to 3,000 meters and one that is not obscured by threat tactical smoke.

- "Given the stated battlefield and a force ratio of 4:1, the defending company lost with two TOWs and obtained a decisive victory, i.e., destroyed the entire threat force, with 12 TOWs. It was found that marginal increases in effectiveness diminished as the number of TOWs approach ten. A marginal victory was obtained with six TOWs. It was determined that proliferation of TOW was desirable with the

optimum number falling in the range of 6 to 10.

- "The defenders can no longer fight a static defense due to the numerical superiority of the threat. When the defenders remain in position, the attacking force frequently closes to ranges that allow a large number of high-rate-of fire weapons to become very effective, thereby overwhelming the defenders.

- "The ZSU-23-4 is an effective anti-TOW weapon but can be removed from the threat due to ease in recognition, its small quantities, and its vulnerability."⁶⁶

Table 4 shows battle results extracted when the Blue forces were at 50 percent strength for the 1976 base cases. The table shows the fraction survivors of the Red and Blue forces and the number of kills by the TOWs and the number of TOWs killed by the threat.⁶⁷

Table 5 shows the results of the 1976 Cases with 4 M-113 TOW added to the defending teams for a total of 8 TOWs for the Mech Hvy Tm and 6 TOWs for the Tank Hvy Tm.⁶⁸

The 1976 cases with additional TOWs added (Table 5), show that it is possible to attain a force mix which will attrit a threat force sufficiently to break the momentum of the threat attack and allow the defenders to move to an alternate position from which they can engage the next assaulting echelon of the threat division. Additionally, the data shows that the TOWs are capable of inflicting a significant number of casualties on the attacking force. It is assumed

Table 5
1976 Cases with Four TOWs Added

| | <u>MECH HVY TM VS. TANK THREAT</u> | | | | | <u>TOTAL</u> | <u>KILLS/TOW</u> |
|-------------|------------------------------------|-------------|-----------------------------------------------|---------------|-----------------|--------------|------------------|
| | <u>RED TANK</u> | <u>BRDM</u> | <u>BMP</u> | <u>ZSU-22</u> | <u>RED ARTY</u> | | |
| TOW KILLS | 48.56 | | 6.85 | 1.68 | | 57.09 | 7.14 |
| KILLED TOWS | .81 | | .17 | | 1.27 | 2.25 | |
| | | | <u>TANK HVY TM VS. TANK THREAT</u> | | | | |
| | | | <u>FRACTION SURVIVORS - BLUE .5 RED .36</u> | | | | |
| TOW KILLS | 37.72 | | 7.36 | 1.04 | | 46.12 | 7.69 |
| KILLED TOWS | .19 | | .01 | | .87 | 1.07 | |
| | | | <u>MECH HVY TM VS. MOTORIZED THREAT</u> | | | | |
| | | | <u>FRACTION SURVIVORS - BLUE .51 RED .59*</u> | | | | |
| TOW KILLS | 15.23 | | 22.21 | .02 | | 37.49 | 4.69* |
| KILLED TOWS | .08 | .01 | .12 | 1.42 | 1.10 | 2.73 | |
| | | | <u>TANK HVY TM VS. MOTORIZED THREAT</u> | | | | |
| | | | <u>FRACTION SURVIVORS - BLUE .49 RED .66*</u> | | | | |
| TOW KILLS | 12.43 | | 16.86 | | | 29.29 | 4.88* |
| KILLED TOWS | .03 | .01 | .03 | 1.28 | .79 | 2.14 | |

*"The motorized threat had 60 BMP vs. 20 BMP for tank threat; therefore it could engage and destroy the defenders earlier in the battle at a longer range. BLDM plays firepower kills, not mobility kills, thus there is a smaller probability of a firepower kill given a hit against a BMP than against the T-62 tanks. It is apparently very difficult to incapacitate both weapon systems on the BMP (the SAGGER and the 7mm gun). If BLDM played mobility kills, many of the BMP's would not get close enough to the defender to use the 73mm gun, and the nature of the outcome would change considerably."

that 60 percent attrition on the attacker will disorganize him sufficiently to cause him to break off his attack.

By analyzing the TETAM and BLDM data, additional TOW section/squad measures of effectiveness can be deduced.

-Once line-of-sight occurs, the TOW squad in hull defilade should be able to initiate an engagement within 28 seconds.

-TOW squads must engage targets from hull defilade positions or using the "hide" position technique. As a corollary, positions must be well camouflaged to minimize random detections by the threat.

-Since the threat crews will detect the TOW squad about once out of every three firings, the TOW squad must move to an alternate firing position after each second firing. This applies when using a hull defilade position. When firing from a "hide" position, the TOW squad must move to an alternate firing position after every firing. This is because of the long exposure time (a maximum of 39 seconds) and the high probability of detection due to movement and launch signature cues.

-TOW squads must engage approaching armor at the greatest possible range. If terrain allows, maximum engagements should occur at ranges greater than 1,500m. This minimizes TOW squad vulnerability by engaging approaching armor before they can close to a range where their main gun is effective.

-TOW sections must "kill" a minimum of ten (10) threat weapons systems (tank, APC, etc.) for every TOW lost. Each M-113 APC TOW carries 10 TOW missiles. TETAM data indicates that on the average, it took two TOW rounds to achieve a kill. Therefore, based on the number of missiles carried per M-113 TOW, each TOW squad is limited to an average of five kills. This also assumes that the threat uses the fire and movement technique for half the time and the rapid approach technique the other half. If the threat uses the rapid approach technique each TOW should achieve 11 kills before it is lost. In order to allow the defenders to disengage, it is assumed that the defending company will attrit the attackers sufficiently to break up the momentum of the attack. The company would then move to an alternate position where additional ammunition would be available. BLDM data shows the average number of kills per TOW to be 6.45 under ideal conditions. It is assumed that the defending companies played in BLDM would move to an alternate position after suffering 50 percent casualties. This data supports establishing a minimum standard 10 kills per TOW section while at the company primary defensive position; however, in order to carry on the fight at the company alternate position, at least one TOW in the section must survive.

-TOW squads/sections must be as effective at night as they are during the day. The new TOW night sight will enhance TOW effectiveness at night.

-TOW crews must fire effectively when under artillery fire. Use of the TOW ballistic blanket, hull defilade positions, and good camouflage discipline will reduce the effects of artillery fire; however, the gunner must be trained to fire effectively when under fire.

It can be seen that TOW crew measures of effectiveness generate three general areas of required training for TOW squads. These are:

a. TOW tracking to include the ability to fire effectively during the day, at night, in a chemical environment, and while under artillery fire.

b. Basic TOW section tactical employment to include preparation of positions, fire control, and night employment techniques.

c. Battlefield effectiveness as measured by the ability of the TOW section to "kill" at least 10 threat weapon systems in a simulated battlefield for every TOW lost while at the company primary defensive position.

-How can MILES be used to quantify the APC TOW measures of effectiveness?

As indicated above, the three general areas of TOW employment in which the TOW section must be proficient are TOW tracking, basic TOW tactical employment, and battlefield effectiveness. MILES can be used to assist in training/evaluating the TOW crew in performing the various required tasks.

It will be recalled that the basic level/TOW tracking tasks were:

- a. Prepare the weapon for firing.
- b. Know the extent of the TOW backblast area.
- c. Know the TOW misfire procedures.
- d. Track both stationary and moving targets out to ranges of 3,000m with moving targets traveling from 10 mph to 35-56 mph.
- e. Track at night using the TOW night sight.
- f. In a chemical warfare environment with chemical protective equipment on, track effectively both day and night.
- g. Track successfully while being suppressed by artillery and smoke.
- h. Perform operator maintenance on the TOW and M-113 APC.

Testing and training in the ability to track with the TOWs is presently accomplished with the M-70 training set and on occasion by firing an actual TOW missile. MILES, however, can be used in the advanced stages of TOW gunnery training to develop the ability of the gunner to track moving targets at various ranges and while executing evasive maneuvers.

While the M-70 training set is an excellent device to use in training the gunner in the basics of TOW tracking, it is limited in that it cannot be used at ranges in excess of 1,000 meters (long ranges are simulated by using the LOW tracking rate of 5 milliradians per second).

AD-A044 526

ARMY COMMAND AND GENERAL STAFF COLL FORT LEAVENWORTH KANS F/G 20/5
THE MULTIPLE INTEGRATED LASER ENGAGEMENT SYSTEM (MILES) AND THE--ETC(U)
JUN 77 A MUNERA

UNCLASSIFIED

NL

2 OF 2
ADA044526

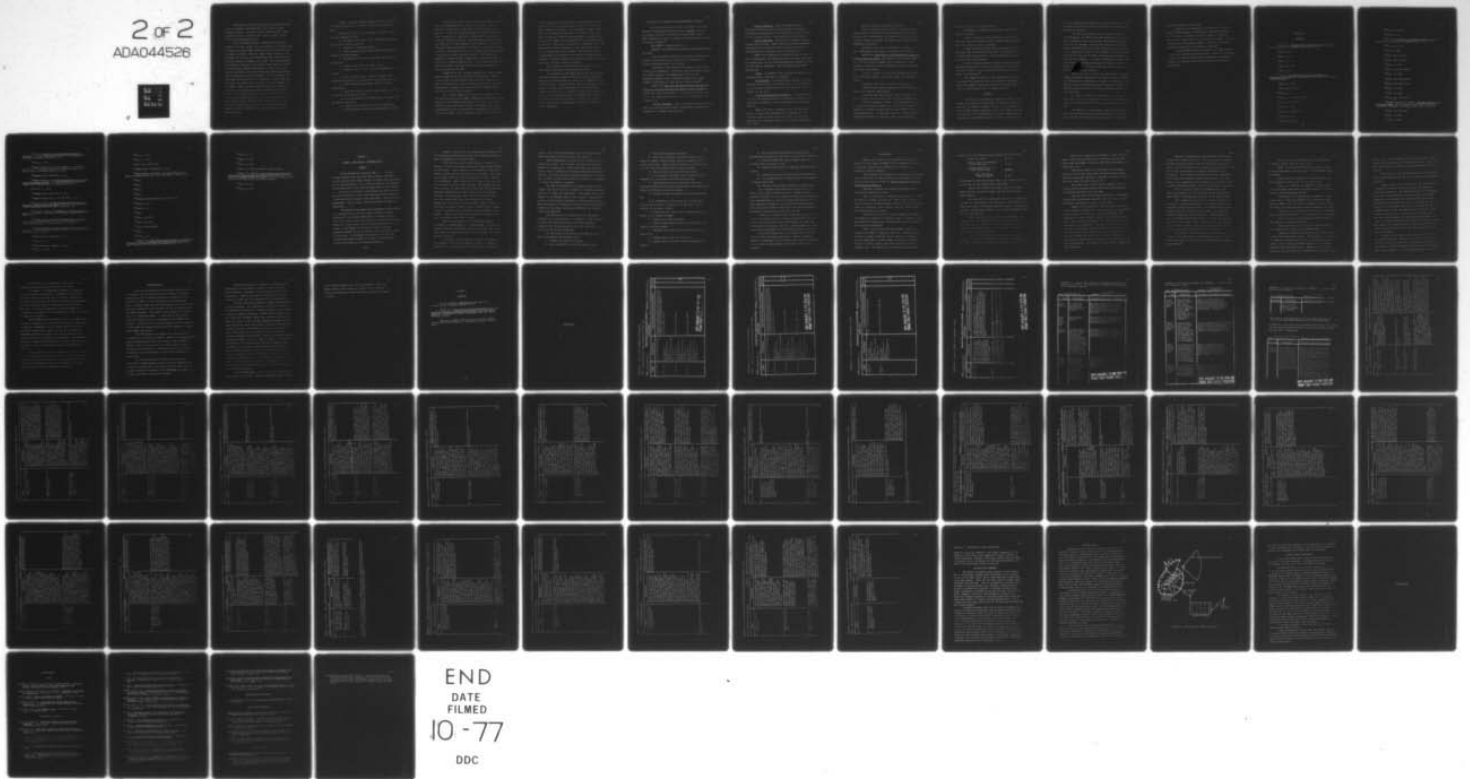

END
DATE
FILMED
10-77
DDC

Additionally the IR target mounted on an APC or jeep is not a realistic representation of an attacking tank/mechanized force. The target vehicle normally moves along a specified path at a constant rate without trying to evade the incoming simulated missile.

With the MILES TOW laser transmitter in the "continuous fire" mode (laser is on for duration of trigger pull), the gunner can track tanks equipped with laser detectors out to ranges of 3,000m. When the target tank is paired by the TOW laser in this mode, an intermittent tone is activated in the kill indicator assembly of the tank. The tone continues for duration of pairing. By taping a radio handset so that it continuously transmits and placing it next to the kill indicator assembly, the intermittent tone indicating pairing can be transmitted to the TOW gunner. In this fashion, the TOW gunner can tell when he is "on-target." Using MILES in this mode, the gunner can track tanks at various ranges out to 3,000m. Tanks can travel either at constant speeds, or they can try to evade the incoming simulated TOW missile. Using this technique allows the gunner to become proficient in estimating ranges, lengths of intervisibility segments, and vehicle speeds. Also, the gunner will learn how to keep the TOW on target when the tank is executing hard evasive maneuvers. This training can be done at night as well as during the day.

In basic tactical training MILES can be used to check the TOW crew's ability to perform a number of the required tasks.

The following were the intermediate level/basic TOW tactical employment tasks:

- a. Reconnoiter and select exact firing positions and routes to the firing positions.
- b. Prepare the firing positions.
- c. Insure mutual support within the section and with adjacent antitank weapons.
- d. Integrate the security of the TOW crew with the local units.
- e. Prepare range cards and target lists.
- f. Control fires to insure efficient engagement of targets.
- g. Move quickly between primary, alternate, and supplementary positions as required by the tactical situation.
- h. Adjust mortar and artillery fires to include illumination.
- i. Using the TOW night sight, engage targets at night as effectively as during the day.
- j. If contaminated by a chemical agent, decontaminate the TOW and M-113 APC.
- k. Request and coordinate resupply of ammunition.
- l. Identify Soviet tanks and antitank weapon systems.

MILES can be used to check how well the TOW crew prepared and camouflaged their defensive positions. Once a position is prepared by a TOW crew, the crew occupies the position. A tank (or a TOW simulating the BRDM) equipped with laser transmitter is positioned 1,500m from the position in a typical overwatch position. The tank gunner using the main gun sight and the tank commander using binoculars, attempt to locate the TOW position which is located in a defensive sector 500m wide. The tank crew is given 3 minutes and one opportunity to locate and pinpoint the TOW position. The pinpoint is checked by firing the laser transmitter in the continuous fire mode at the suspected TOW position. If the tank crew has pinpointed the TOW, a pairing will occur, and the intermittent tone will sound on the TOW.

MILES can be used to check range cards. With the TOW laser transmitter in the continuous fire mode and a target vehicle (tank or APC) equipped with detectors in the sector of fire, coverage around target reference points can be verified. Additionally, deadspace and intervisibility segments within the sector of fire can be checked.

In a similar manner TOW section fire control techniques can be checked using MILES. Engagement priorities, firing sequence, fire commands, patterns of fire, and use of target reference points can all be checked with MILES. This can be accomplished by first setting the TOW transmitter in the continuous fire mode. With a simulated threat of 4-6 tanks and

2-4 APC (equipped with MILES detectors) approaching in the sector of fire, the section under control of the section leader engages the targets. The tank/track commander (TC) hears the intermittent tone when he is paired. At a time after initiation of pairing corresponding to the TOW flight time for that range, the TC would raise a red flag and stop his vehicle. This would correspond to a simulated kill. The TOW section continues engaging in this fashion until all threat vehicles have been "killed." Watching the sequence of engagement and listening to the TOW section/squad fire commands, evaluators/trainers can monitor how well the section implemented the fire control techniques.

The techniques described above can also be used to check TOW section/squad night firing procedures.

On an advanced level MILES can be used in real-time two-sided casualty assessment battles to see how well the TOW section performs under the stress of a simulated battle-field situation. In this case the TOW section would be pitted against 10 tanks or APC TOW simulating tanks (TOW laser transmitter can be set to simulate tank main gun characteristics for use when tanks are not available) and 2 BRDM. The TOW section would be required to "kill" ten of the 12 threat vehicles while losing only one TOW in a simulated combat engagement.

THE ARTEP AS IT RELATES TO TOW PERFORMANCE STANDARDS

As has been previously stated, the ARTEP or the Army Training and Evaluation Program provides minimum standards of performance which must be achieved by Army combat units.

ARTEP standards are used to evaluate units and provide a basis for future training.⁷⁰

"The ARTEP is characterized by:

-Emphasis on fundamental, frequently performed missions and tasks.

-Unit proficiency judged on the basis of mission performance rather than on the extent to which elaborate or detailed procedures have been followed.

-Concurrent, multi-echelon (as opposed to sequential) training and evaluation is encouraged and facilitated; however, the modular design of the ARTEP permits the use of a sequential approach--from crew/squad through platoon and company to battalion--if that system is appropriate.⁷¹

ARTEP 7-45, Army Training and Evaluation Program for Mechanized Infantry Battalion and Combined Arms Task Force, categorizes tasks and standards into missions at Levels 1, 2, and 3. The following are Level 1, 2, and 3 definitions used in ARTEP 7-45:

-"Level 1 Missions. Those crew/squad through battalion/task force missions which compose the minimum acceptable performance for a combat ready battalion.

-Level 2 Missions. Those crew/squad through battalion/task force missions which compose the minimum acceptable performance for a battalion which is within three to four training weeks of attaining Level 1 proficiency.

-Level 3 Missions. All Level 2 crew/squad through company/team missions. These compose the minimum acceptable performance for a battalion which is within five to six training weeks of attaining Level 1 proficiency."⁷²

ARTEP 7-45 standards are written in terms of the task to be accomplished; the conditions under which the task will be accomplished; and the training/evaluation standard to which the task will be performed. The following are pertinent definitions:

-Task. A statement which specifies an action to be performed by an individual or team/unit.

-Condition(s). A statement which specifies the circumstances under which a particular task is to be performed, e.g., information/equipment provided or denied for the performance of the task.

-Training/Evaluation Standard(s). A statement which specifies the minimum acceptable proficiency required of an individual or team/unit in the performance of a particular task."⁷³

ARTEP 7-45 Level 3 standards tests the TOW squad's ability to place the APC/TOW and M-70 training set into operation, and the crew's ability to track with the M-70 training set at tracking rates of 5, 15, and 25 milliradian per second.

Level 2 tasks are identical to level 3.

Level 1 tasks include all level 3 tasks plus night familiarization tracking for the TOW squad using the M-70 training set. Additionally, the TOW section is required to prepare defensive positions and engage enemy vehicles using REALTRAIN techniques.⁷⁴

Appendix 1 and 2 lists the ARTEP 7-45 Level 1, 2, and 3 TOW squad/section tasks, conditions and standards.

ARTEP 71-2, Army Training and Evaluation Program for Combined Arms Task Force, when finished will replace ARTEP 7-45. A draft version of ARTEP 71-2, in addition to tasks similar to those described in Appendices 1 and 2, has these additional requirements:

-Identify armored vehicles both friendly and enemy. This requirement applies to both the gunner and assistant gunner.

-Simulated TOW firings under time constraints.

-Night tracking under illumination with standards the same as the daylight requirements.

-A firing line 20m long and a target vehicle road 300 to 1,000m from the firing line and 500 to 1,000m long.

-Fifteen simulated firings. The TOW squad must meet or exceed the stated standards for 10 of the 15 firings.⁷⁵

Appendix 3 contains excerpts from the draft ARTEP 71-2 for the TOW squad/section. It should be noted that in addition to emphasizing accuracy in tracking, speed in reloading and

firing a second time is also stressed.

The ARTEP 71-2 (DRAFT) also redefines the mission levels as follows:

-Level 1 Missions--Those minimum crew/squad through battalion task force missions that a combat ready battalion task force should be able to perform.

-Level 2 Missions--Those minimum crew/squad through battalion task force missions that must be performed by a battalion task force before it can be classified as having attained Level 2 proficiency.

-Level 3 Missions--Those minimum crew/squad through company/team missions that must be performed by a battalion task force before it can be classified as having attained Level 3 proficiency."⁷⁶

The changed missions in draft ARTEP 71-2 reflect a trend away from tying the levels of training proficiency with unit readiness conditions as specified in AR 220-1 (in terms of weeks before a unit is combat ready).⁷⁷

SUMMARY

The TOW is a tube-launched, optically tracked, wire-command link guided missile capable of defeating any known armor out to ranges of 3,000m. It has a .9 hit probability at stationary targets throughout most of its range. Due to the high cost of the TOW missile, the M-70 training set was developed to train TOW gunners how to track. An infra-red

emitting target source mounted on a tracked or wheeled vehicle provides line-of-sight reference data for use in determining tracking proficiency.

The TOW section consists of the section leader and two TOW squads. The TOW section when moving into a defensive area, reconnoiters and selects exact TOW firing positions. Positions are prepared, coordination affected with adjacent units, and range cards with target reference points are prepared. During the conduct of the defense, the section leader controls the fires of the TOW's using various techniques of fire and fire commands. To reduce vulnerability, squads move from primary to alternate positions as required. In the modern battlefield, the TOW section must fight at night as well as during the day.

Within its sector of fire, the TOW section can expect roughly 100 threat tanks/armored personnel carriers attacking to breakthrough the defensive positions. To effectively engage this force, the TOW section must engage the attacker at maximum ranges and attrit that force 10 weapons systems for every TOW lost.

The Soviet threat can be expected to use chemical munitions in the future battlefield; therefore, the TOW section must function effectively in a chemical warfare environment.

TOW measures of effectiveness fall into three major categories--TOW tracking, basic TOW section tactical employment, and TOW effectiveness in the battlefield. The TOW

section must master these areas.

MILES in the "continuous fire" mode can be used to assist the TOW gunner in refining his tracking techniques out to ranges of 3,000m, to pinpoint defensive positions, and to check range cards and fire control techniques. In its standard mode of employment MILES is useful in providing a realistic simulation of the modern battlefield.

Current ARTEP standards primarily test TOW tracking proficiency with the M-70 training set. Little or no emphasis is given to developing TOW tactical employment techniques to include the ability to work effectively in a battlefield environment.

CHAPTER IV

ENDNOTES

¹TC 23-23, TOW Heavy Antitank Weapon System w/C1-C2, HQ., Department of the Army, July 1970, p. 12.

²Ibid., p. 5.

³Ibid., p. 3.

⁴Ibid., p. 9.

⁵Ibid., pp. 7-9.

⁶Ibid., p. 4.

⁷TC 7-24, Antiarmor Tactics and Techniques for Mechanized Infantry, HQ., Department of the Army, 30 September 1975, pp. 2-12.

⁸Ibid., p. B-18.

⁹TC 23-23, pp. 7-8.

¹⁰Ibid., p. 7.

¹¹Ibid., pp. 27-28, 35, 137.

¹²Ibid., pp. 128-129.

¹³Ibid., p. 133.

¹⁴Ibid., pp. 138-139.

¹⁵Ibid., p. 35.

¹⁶Ibid., pp. 34-35.

- ¹⁷Ibid., pp. 40-41.
- ¹⁸Ibid., p. 45.
- ¹⁹TOE 7-47H, Mechanized Infantry Company, w/C13, HQ.,
Department of the Army, 1 September 1976, p. 4.
- ²⁰TC 7-24, p. 1-4.
- ²¹Ibid., p. B-2.
- ²²Ibid., pp. B-3, B-4.
- ²³Ibid., pp. B-4-B-9.
- ²⁴Ibid., p. 2-21.
- ²⁵Ibid., pp. B-10--B-16.
- ²⁶Ibid., p. B-18.
- ²⁷Ibid., pp. B-24--B-28.
- ²⁸Ibid., pp. B-29, B-30.
- ²⁹Ibid., p. B-31.
- ³⁰Ibid., p. B-33.
- ³¹Ibid., pp. B-33, B-34.
- ³²USAITAD Report No. 14-U-76, Military Operations of
the Soviet Army, U.S. Army Intelligence Threat Analysis
Detachment, Arlington, Virginia, 25 May 1976, pp. 13-14.
- ³³Ibid., pp. 109, 120.
- ³⁴Ibid., p. 157.
- ³⁵Ibid., p. 135.

³⁶RB 30-2, Selected U.S. and Soviet Weapons and Equipment, U.S. Army Command and General Staff College, Fort Leavenworth, Kansas, July 1976, p. 13.

³⁷Ibid., p. 156.

³⁸TRADOC Bulletin #8, Modern Weapons on the Modern Battlefield, U.S. Army Training and Doctrine Command, Fort Monroe, VA., 31 December 1975, pp. 13-14.

³⁹USAITAD Report #14-U-76, p. 162.

⁴⁰TRADOC Bulletin #1, Range and Lethality of U.S. and Soviet Anti-Armor Weapons, U.S. Army Training and Doctrine Command, Fort Monroe, VA., 30 September 1975, p. 8.

⁴¹TC 7-24, p. 4-10.

⁴²USAITAD Report #14-4-76, p. 215.

⁴³TRADOC Bulletin #1, p. 23; RB 30-2, p. 24.

⁴⁴Larry M. Pique, Technical Paper TP-76, Analysis of Antiarmor Effectiveness with BLDM, U.S. Army Combined Arms Combat Development Activity, April 1976, pp. 5-7.

⁴⁵"Chemical Warfare," DA Pamphlet 360-831, Commanders Call, Headquarters, Department of the Army, January-February 1977, p. 5.

⁴⁶Author's notes and TETAM Extended Analysis, Final Report Vol. I, BDM Scientific Support Laboratories, Fort Leavenworth, Kansas, 24 December 1974, p. VIII-1.

⁴⁷TETAM, Final Report Vol. I (Executive Summary Phases I & II), U.S. Army Combat Developments Experimentation Command, September 1973, p. 4-8.

⁴⁸TETAM Extended Analysis, p. 1-6.

⁴⁹Ibid., p. 1-4.

⁵⁰TETAM Executive Summary, p. 4-12.

⁵¹Ibid., p. 4-16.

⁵²Ibid., p. 5-6.

⁵³Ibid., p. 5-11.

⁵⁴Ibid., pp. 5-14, 5-15.

⁵⁵TETAM Extended Analysis, p. 1-6.

⁵⁶TETAM Summary Briefing, U.S. Army Combined Arms
Combat Development Activity, Fort Leavenworth, Kansas, 1974.

⁵⁷Ibid.

⁵⁸Ibid.

⁵⁹Ibid.

⁶⁰Ibid.

⁶¹TETAM Extended Analysis, pp. 1-18, X-5.

⁶²Pique, p. 6.

⁶³Ibid., p. 7.

⁶⁴Ibid.

⁶⁵Ibid., pp. 7-8.

⁶⁶Ibid., pp. 8-9.

⁶⁷Ibid., data package.

⁶⁸Ibid.

⁶⁹Ibid., p. 9.

⁷⁰ARTEP 7-45, Army Training and Evaluation Program for
Mechanized Infantry Battalion and Combined Arms Task Force,
HQ., Department of the Army, 9 September 1975, p. 3.

⁷¹Ibid., p. 4.

⁷²Ibid., p. B-1.

⁷³Ibid., p. B-2.

⁷⁴Ibid., p. D-15-2, F-29-2, F-29-3, F-30-2.

⁷⁵ARTEP 71-2 (DRAFT), Army Training and Evaluation Program for Combined Arms Task Force, HQ., Department of the Army, 15 September 1976, pp. 6-33-1 to 6-33-4, 6-33A, 7-36-1 to 7-36-4, 7-36-A, 8-47-1 to 8-47-4, 8-47-A.

⁷⁶Ibid., p. 3-1.

⁷⁷Ibid., p. 4-4.

CHAPTER V

SUMMARY, CONCLUSIONS, RECOMMENDATIONS

SUMMARY

S.L.A. Marshal has suggested that, . . . the individual soldier first goes into battle without the facts he most requires--the simple details of common human experience on the field of battle. As a result, he goes to the supremely testing experience of his lifetime almost as a total stranger . . . the price for failure is paid all up and down the line; men go into action the first time haltingly and gropingly, as if they were lost at night in the deep woods. Lives are wasted unnecessary. Time is lost. Ground that might be taken is overlooked. . . .¹

The Multiple Integrated Laser Engagement System (MILES) is a training device that will permit two-sided casualty assessment in the "mock" battlefield of training and will remedy the training shortfalls alluded to by General Marshall. MILES will revolutionize military training methods and techniques. Using MILES, the individual soldier receives immediate feedback as to the effects of his actions in training exercises. By "killing" his opponent if he performs correctly and being "killed" if he errs, he will learn to perform effectively on the modern battlefield.

MILES is currently in the engineering development phase of the materiel acquisition process, and production quantities will be available in the early 1980's.

MILES uses low power eyesafe lasers to simulate the effects of direct fire weapons such as the APC mounted TOW and the M-60 tank. Laser transmitters are mounted on individual weapons systems and are boresighted to the weapon. Each laser has a unique laser code which identifies the type of weapon being simulated. When simulating the firing of the main tank gun the laser is on for three seconds. For casualty assessment to occur, the laser must pair with laser energy detectors (sensors) mounted on the target vehicle for one of those seconds. The probability that a valid laser pairing will occur at a particular range is the same as the actual probability of hit for the tank main gun. When a "kill" is assessed, the target vehicle's laser is deactivated, a smoke grenade is ignited, and a continuous tone is sounded for one minute. Near misses can occur, in which case a one second tone is sounded at the target vehicle.

With the laser mounted on the APC/TOW, casualty assessment is accomplished in a similar manner. On the TOW, however, the total laser "on" time is 10 seconds. The gunner must track the target for 9 out of the 10 seconds for a valid pairing to occur.

In order to provide added flexibility in training, the capability will exist in MILES to adjust the TOW laser transmitter so it will fire with characteristics simulating

a tank. This will allow APC TOWs to act the role of enemy tanks when tanks are not available for training.

Laser transmitters can also be set to fire in a "continuous fire" mode. In this mode, the laser will fire for duration of trigger pull. When a pairing occurs, an intermittent tone is sounded at the target vehicle for duration of pairing. This mode provides additional flexibility in training, in that the laser can be used as a "pointer" to designate the target the gunner is engaging.

The TOW or tube-launched, optically tracked, wire-command link guided missile is capable of defeating any known armor out to ranges of 3,000 meters. The flight time for the missile to its maximum range is 16.5 seconds. Training TOW gunners on TOW tracking techniques is done primarily using the M-70 training set, an infra-red training device that provides feedback to the gunner indicating deviations from line-of-sight during tracking.

The TOW section is organized into two TOW squads commanded by a section leader. In addition to TOW tracking, the TOW section must master basic tactical employment techniques and the day-to-day details that will allow it to survive in the modern battlefield.

On a very basic level (Level 3) the TOW crew must be able to accomplish the following tasks:

1. Prepare the weapon for firing.
2. Know the extent of the TOW backblast area.

3. Know the TOW misfire procedures.
4. Track both stationary and moving targets out to ranges of 3,000m. Moving targets travel at speeds of 10 mph, 35 mph, and 55 mph. These speeds correspond to tracking rates of 5, 15, and 25 milliradians per second at 1,000m.
5. Track at night using the TOW night sight.
6. In a chemical environment with chemical protective equipment on, track effectively both day and night.
7. Track effectively while artillery rounds are exploding nearby and with smoke intermittently obscuring vision between the TOW position and the target.
8. Perform operator maintenance on the TOW and M-113 APC.

At an intermediate level (Level 2), the TOW squad/section must be able to accomplish the following tasks in addition to the Level 3 tasks:

1. Reconnoiter and select exact firing positions and routes to the firing positions.
2. Prepare the firing positions.
3. Insure mutual support within the section and with adjacent antitank weapons.
4. Integrate the security of the TOW crew with the local units.
5. Prepare range cards and target lists.
6. Control fires to insure efficient engagement of targets.

7. Move quickly between primary, alternate and supplementary positions as required by the tactical situation.

8. Using the TOW night sight, engage targets at night as effectively as during the day.

9. Identify Soviet and U.S. tank and antitank weapon systems.

10. Adjust mortar and artillery, HE and illumination.

11. If contaminated by a chemical agent, decontaminate the TOW and M-113 APC.

12. Request and coordinate resupply of ammunition.

On an advanced level (Level 1), in addition to the Level 2 and 3 tasks the TOW section at a company primary defensive position is pitted against a threat armored/mechanized force representative of two first echelon battalions using the rapid approach technique in a two-sided free play exercise. The section must "kill" at least 10 of the attacking armored/mechanized vehicles while losing only one TOW.

MILES in its standard mode of employment can be used to test the TOW section in a simulated battlefield situation. In the "continuous fire" mode, MILES assists the TOW gunner in refining his tracking techniques, checking range cards and fire control techniques, and pinpointing defensive positions.

The M-70 training set is the primary tool currently in use to test TOW squad proficiency. Current standards require the TOW squad to successfully track targets travelling at 5, 15, and 25 milliradians per second for 10 out of 15 attempts.

CONCLUSIONS

Based on the answers to the questions discussed in Chapter IV, how should the ARTEP 7-45 be changed as it relates to antiarmor training and evaluation of the TOW in the Mechanized Infantry Company?

This question can be answered by stating the previously listed tasks that the TOW squad/section must perform at each level of proficiency in terms of tasks, conditions and training/evaluation standards.

Appendix 4 contains the proposed TOW squad Level 3 training and evaluation outline.

Task 1, crew drill, is extracted from the current ARTEP and places the weapon into action. Tasks 2 and 3 require the crew to describe the TOW backblast area and misfire procedures. These are elementary safety related tasks the TOW crew must know before firing the weapon.

Tasks 4-6 are extracted from the ARTEP 71-2 (DRAFT) and require the gunner and assistant gunner to engage a target using the M-70 training set. Accuracy and speed in reloading and firing are emphasized.

Task 7 is the first task using MILES. This task requires the gunner to engage a tank moving across an inter-visibility segment (from one covered position to another). For the range band of 2,000-3,000m, the gunner is given 41 seconds to detect, acquire and track the target for the required time. The following is a breakdown of mean times

expected for the various actions required by the TOW crew:

| | |
|-------------------------------------------------|---------------|
| Detect the target | 20 sec |
| Time to start of engagement after detection | 8 sec |
| Average tracking time for 2,000-3,000m range | <u>13 sec</u> |
| Total Time Target Tank is Exposed | 41 sec |

The required 13 seconds tracking time is the average missile flight time for the 2,000-3,000m range bands.

Tasks 8 and 9 differ from task 7 only in the range bands used and the missile flight time (10 and 5 seconds respectively).

The range band of 2,000-3,000m requires the TOW gunner to track at the extremes of the TOW range. The 1,500-2,500m range band covers the typical engagement ranges in fairly open terrain. The 500-1,500m range is the typical engagement range for cluttered terrain.

Tasks 10-12 require the gunner to effectively track a tank that is executing hard evasive maneuvers. This exercise tests the gunner's reflexes and ability to stay on target when confronted with an evasive target. Range bands used are the same as tasks 7-9.

Tasks 13 and 14 require the gunner to track effectively at night using the TOW night sight and the M-70 training set. Otherwise, the tasks are identical to tasks 4 and 5.

Tasks 15-17 requires the TOW squad to detect and engage a target tank during hours of darkness using the TOW night sight and MILES. The three range bands previously discussed are used.

Tasks 18-21 require the TOW gunner and assistant gunner to effectively track while wearing chemical warfare protective masks and clothing. Tracking is performed both day and night using the M-70 training set.

Tasks 22-23 test the TOW squad's ability to detect targets and successfully engage them while being harrassed by simulated artillery fire and smoke.

Task 24 tests the TOW squads knowledge of elementary TOW and M-113 maintenance procedures and their use of these procedures throughout the course of the tests.

ARTEP 7-45 and ARTEP 71-2 (Draft) require 67 percent of the tracking sequences (or 10 out of 15) to be accomplished satisfactorily for a TOW squad to pass the ARTEP. This requirement is not stringent enough. On the modern battlefield, when fighting outnumbered, the ability to fire first with accuracy is important. TOW crews must be able to use the TOW to its maximum effectiveness under the various conditions expected to be encountered in the battlefield. The proposed standard for passing the tracking sequences is satisfactory completion of 80 percent of the tasks (or 48 of the 60 sequences). This allows for a 20 percent variance in test conditions.

Appendix 5 contains the proposed Level 2 TOW section training and evaluation outline. To be proficient at Level 2, the TOW section must also be tested on and pass the Level 3 tasks. The Level 2 tasks test in detail those actions the TOW section must accomplish in a tactical environment to be successful. Once a TOW section meets the Level 2 standards, it will have the detailed knowledge and expertise that will allow it to be imaginative and innovative in surviving in the simulated battlefield which is part of the Level 1 standards.

Task 1 of Level 2 places the TOW section in the tactical environment for the tests and allows the section/squad leader to reconnoiter routes and the defensive sector.

Task 2 requires the section to prepare the defensive positions. A mechanized company in the active defense will physically occupy a 1,500m sector. Each TOW section will be located within 1/3 of this sector of 500m. At a range of 1,500m the tank main gun is effective. Overwatching tanks of the attacking threat will attempt to locate the defenders position at this range. Three minutes is felt to be adequate time to allow the tank to locate the defending TOW. MILES is used to pinpoint the TOW position, if detected.

Task 3 and 4 tests the coverage of the primary sector of fire by the TOW section. Each TOW must be able to fire in the major part of the sector both from primary and alternate positions.

Task 5 and 6 tests the ability of the TOW section to prepare firing lists and range cards.

Tasks 7-9 test the TOW sections ability to work as a team and implement three patterns of fire (FRONTAL, CROSS, and DEPTH).

Tasks 10-12 are identical to 7-9 except that they are performed at night using the TOW night sight.

Task 13 is extracted from ARTEP 71-2 (Draft) and tests the gunners and assistant gunners ability to identify friendly and enemy armored vehicles.

Tasks 14 and 15 are adaptations of ARTEP 7-45 81mm mortar tasks. Times and standards are derived from data found in ARTEP 7-45.² At Level 2 to qualify in these tasks, one member per squad must satisfactorily accomplish the tasks.

Task 16 tests the TOW section's ability to decontaminate the TOW and M-113 APC in a chemical warfare environment.

Task 17 tests the section/squad leaders knowledge of TOW ammunition resupply procedures.

Eighty percent (or 14 of the 18) tracking sequences with MILES must be satisfactorily accomplished.

Appendix 6 contains the proposed Level 1 TOW section training and evaluation outline. To be proficient at Level 1, the TOW section must also be tested on and pass the Level 3 tasks. Level 1 tasks uses MILES capabilities to simulate two-sided tank-antitank battles. Emphasis is not on the details of how the TOW section performed the task, but on the

results, i.e., did the TOW section kill the required number of vehicles while sustaining the minimum casualties? Some Level 2 tasks which cannot be tested in a two-sided battle are also included.

Tasks 1 and 2 place the TOW section in the tactical scenario and allows the section time to prepare the defensive positions.

Tasks 3 and 4 test the ability of the TOW section to accomplish its mission both day and night in a simulated battlefield situation. The TOW section must kill a minimum of 10 threat tanks/APC while losing a maximum of one TOW. Reasons for this standard has been previously discussed. Restrictions on the number of vehicles overwatching and the location of the sequence termination line (STL) are based on TETAM data. Twelve tanks/BRDM makeup the threat. This allows a sufficient target density for the TOW section to meet the stated standard. To satisfactorily complete tasks 3 and 4, the TOW section must pass four of the six sequences. This allows for variations in test conditions and for the threat identifying some of the TOW firing positions after the first sequence.

Tasks 5-9 are Level 2 tasks not tested as part of the two-sided battle. The only difference is that for the section to pass the adjustment of 81mm mortar fires tests, two members of each TOW squad must satisfactorily accomplish each task as opposed to one per squad required at Level 2.

In addition to the conclusions stated above, the following conclusions are derived from this study:

-In Chapter I the REALTRAIN technique of simulating two-sided battles was discussed. REALTRAIN uses controllers with each vehicle to verify kills and misses. Numbers are painted on each vehicle, and kill verification is accomplished by using telescopes that are boresighted to the vehicle's main gun. If a kill is assessed, the vehicle number is radioed to a controller with the opposing side, and the vehicle is taken out of action.

Until MILES becomes available, some of the ARTEP tasks proposed in Appendices 4-6 which require the use of MILES can be adapted to REALTRAIN. As an example, tasks in Appendix 5 which test TOW section patterns of fire can be adapted to REALTRAIN by having the gunner call out the number on the target vehicle he is engaging to a controller. The controller knowing the target array disposition by target vehicle number, can check to see if the pattern of fire is being implemented properly.

-While MILES will greatly enhance battlefield simulations in training, additional work must be done in developing simulations for artillery/mortar fire, mine warfare, and for systems under development such as the HELLFIRE laser guided missile system for the new advanced helicopter.

RECOMMENDATIONS

-That the new TOW squad/section ARTEP standards proposed in Appendices 4-7 be adopted for field testing by the Army. Operational tests of limited quantities of MILES are to be conducted in 1978. At the conclusion of the operational tests, a limited number of the MILES hardware used in the test should be retained by the government for use in verifying the new ARTEP standards. This assumes that no major deficiencies exist in the MILES hardware. If deficiencies exist, they should be corrected prior to government use for ARTEP verification. Field testing of the new standards can be conducted at the Combat Developments Experimentation Command or at some other TRADOC test agency.

-The TOW squad/section ARTEP is not the only one to be affected by the advent of MILES. ARTEPS from tank/mechanized squad through battalion will also change. Also, ARTEPS of numerous other type units such as aviation and air defense artillery will be affected. Additional studies are required to identify and test new MILES related ARTEP standards for these units.

-In the interim period of time until production quantities of MILES hardware become available, REALTRAIN can be used to perform many of the tasks which are MILES related. Detailed research is required on how REALTRAIN techniques can be fully integrated into existing ARTEPS.

-Additional research is required to develop combat simulations for mine warfare, indirect fires, and laser guided missiles. Appendix 7 contains some thoughts on these simulations. Whenever possible in developing new simulation techniques, MILES must be integrated into the simulations.

-As was indicated in Chapter I, MILES will revolutionize army training. The capability to kill and be killed in the simulated battlefield of training provides a major breakthrough in training techniques. Recent tests at CDEC using the Direct Fire Simulator (DFS), have provided a preview of what is to come. In the Parrapet Foxhole experiment (a two-sided platoon vs. squad experiment), using the CDEC DFS, the soldiers involved significantly improved their ability to fight effectively, over a period of time. By receiving immediate feedback from the laser system, the soldiers learned the minute details of what it takes to survive in the modern battlefield. This might be the difference between success and failure in the "first battle" referred to by General Depuy, TRADOC Commander. However, in order to benefit from the use of MILES, it must be available to troop units in sufficient quantities to use in training on a day-to-day basis. In line with these thoughts, the basis of issue for MILES, should be reexamined to insure that the maximum number of systems are produced.

As a minimum MILES should be a basic issue item for each weapon system (tank, APC TOW, TOW Cobra, MICV, etc.) to

include MILES harnesses for exposed personnel. Also, the MILES infantry system should be issued to all personnel in infantry battalions who would normally be expected to engage in combat.

CHAPTER V

ENDNOTES

¹S.L.A. Marshall, Men Against Fire (New York: William Morrow & Company, 1966), p. 37.

²ARTEP 7-45, Army Training and Evaluation Program for Mechanized Infantry Battalion and Combined Arms Task Force w/C1, HQ., Department of Army, 9 September 1975, pp. F-27-2-F-27-A-2, F-27-3.

³Lecture by CDEC briefing group, U.S. Army Command and General Staff College, Ft. Leavenworth, Kansas, January 1977.

APPENDIXES

APPENDIX 1. Level 2 and 3 ARTEP 7-45 Standards.

NOTE: Assistant gunner fires one-third of the time.

UNIT: Antitank Squad (TOW) **TRAINING AND EVALUATION OUTLINE** MISSION: Provide Antitank Fire Support

| TASK | CONDITIONS | TRAINING/EVALUATION STANDARDS | RATING |
|---------------------|--------------------------------------------------------------------------------------------------------------------------------------------------------------------------------|--------------------------------------------------------------------------------------------------------------------------------------------------------------------------------------------------------------------------------------------------------------------------------|--------|
| Conduct crew drill. | Given an APC/TOW and M70 training set. | The squad places the APC/TOW into action in accordance with TC 23-23. A pre-operational check and launcher self test is conducted to insure the system is operational IAW TM 9-1425-470-12. The M70 training set is placed into operation in accordance with TM 9-6920-470-12. | |
| Conduct firings. | Number of firings: 10 Mode: qualify Range qualification position. Low rate Rapid fire: off Tracking rate: Low (5 milliradians/sec) Blast simulators: 10 | Score of 550 or higher is obtained. | |
| Conduct firings. | Number of firings: 10 Mode: qualify Range qualification position. High rate Rapid fire: off Tracking rate: Medium (15 milliradians/sec) Blast simulators: 10 | Score of 750 or higher is obtained. | |
| Conduct firings. | Number of firings: 10 Mode: qualify Range qualification position. High rate Rapid fire: off Tracking rate: High (25 milliradians/sec) Blast simulators: 10 | Score of 550 or higher is obtained. | |

COPY AVAILABLE TO DMC DOES NOT PERMIT FULLY LEGIBLE PHOTOCOPIES

APPENDIX 2. Level 1 ARTEP 7-45 Standards.

NOTE: Assistant gunner fires one-third of the time.

UNIT: Antitank Squad (TOW) MISSION: Provide Antitank Fire Support

TRAINING AND EVALUATION OUTLINE

| TASK | CONDITIONS | TRAINING/EVALUATION STANDARDS | RATING |
|---------------------|--------------------------------------------------------------------------------------------------------------------------------------------------------------------------------|--------------------------------------------------------------------------------------------------------------------------------------------------------------------------------------------------------------------------------------------------------------------------------|--------|
| Conduct crew drill. | Given an APC/TOW and M70 training set. | The squad places the APC/TOW into action in accordance with TC 23-20. A pre-operational check and launcher self test is conducted to insure the system is operational IAW TM 9-1425-470-12. The M70 training set is placed into operation in accordance with TM 9-6920-470-12. | |
| Conduct firings. | Number of firings: 10 Mode: qualify Range qualification position. Low rate Rapid fire: off Tracking rate: Low (5 milliradians/sec) Blast simulators: 10 | Score of 550 or higher is obtained. | |
| Conduct firings. | Number of firings: 10 Mode: qualify Range qualification position. High rate Rapid fire: off Tracking rate: Medium (15 milliradians/sec) Blast simulators: 10 | Score of 750 or higher is obtained. | |
| Conduct firings. | Number of firings: 10 Mode: qualify Range qualification position. High rate Rapid fire: off Tracking rate: High (25 milliradians/sec) Blast simulators: 10 | Score of 550 or higher is obtained. | |

COPY AVAILABLE TO DDC DOES NOT PERMIT FULLY LEGIBLE PRODUCTION

APPENDIX 2. Level 1 ARTEP 7-45 Standards. (Cont)

UNIT: Antitank Squad (TOW) MISSION: Provide Antitank Fire Support

TRAINING AND EVALUATION OUTLINE

| TASK | CONDITIONS | TRAINING/EVALUATION STANDARDS | RATING |
|-------------------------------|--------------------------------------------------------------------------------------------------------------------------------------------------------------------------------------------------------------------------------------------------------------------------------------------------------------------|----------------------------------------------------------------|----------|
| <p>Conduct night firings.</p> | <p>Number of firings: 2 Mode: practice Range qualification position Low rate Rapid fire: off Tracking rate: Low (5 milliradians/sec) Blast simulators: 2</p> | <p>Gunner and assistant gunner successfully engage target.</p> | <p>5</p> |
| <p>Conduct night firings.</p> | <p>Number of firings: 3 Mode: practice Range qualification position Low rate Rapid fire: off Tracking rate: stationary target Blast simulators: none</p> | <p>Gunner and assistant gunner successfully sight target.</p> | <p>5</p> |

COPY AVAILABLE TO DDC DOES NOT PERMIT FULLY LEGIBLE PRODUCTION

APPENDIX 2. Level 1 ARTEP 7-45 Standards. (Cont)

UNIT: Antitank Section/Platoon (406-mm RCVR and TOW) **MISSION:** Provide Antitank Fire Support (REALTRAIN)

TRAINING AND EVALUATION OUTLINE

| TASK | CONDITIONS | TRAINING/EVALUATION STANDARDS | RATING |
|--------------------------------|-----------------------------------------------------------------------------------------------------------------------------------------------------------------------------------------------------------------------------------------------------------------------------------------------------------------------------------------------------------------------------------------------------------------------------------|-----------------------------------------------------------------------------------------------------------------------------------------------------------------------------------------------------------------------------------------------------------------------------------------------------------------------------------------------------------------------------------------------------------------------------------------------------------------------------------------------------------------------------------------------------------------------------------------------------------------------------------------------------------------|--------|
| <p>Engage enemy positions.</p> | <p>During daylight, the section/platoon is located in an assembly area in the vicinity of the defensive position. The evaluator takes the leader forward and shows him the limits of the defensive sector, and issues him an oral defense order which includes the time the section/platoon must be prepared to defend and enemy and friendly situation. No tanks are available to the company or battalion for this mission.</p> | <p>a. Selection of enemy armor avenues of approach. Armor avenues of approach are properly identified. b. Primary, alternate, and supplementary positions. Sufficient positions are designated to adequately cover the armor avenue(s) of approach. Covered and concealed routes between positions are selected. c. Camouflage and concealment. From the last covered and concealed position along the most likely armor avenue of approach, one evaluator without binoculars or special equipment and within a short period cannot identify any of the section/platoon firing positions and/or vehicles.</p> | |
| <p>Engage enemy vehicles.</p> | <p>During daylight, an enemy armor force with a vehicle ratio of 5:1 over the defending section/platoon attacks along avenues of approach assigned by the enemy force leader. Both the enemy and friendly forces use standard techniques of attack. Enemy continues to advance until losses are too great to sustain or until his objective is reached.</p> | <p>Section/platoon engages enemy force and obtains an acceptable hit ratio over that of the enemy. Enemy vehicles are engaged along all avenues of approach from primary, alternate, or supplementary positions. Intelligence and status reports are submitted (to evaluator acting as next higher commander).</p> | |

COPY AVAILABLE TO DDC DOES NOT PERMIT FULLY LEGIBLE PRODUCTION

APPENDIX 3. Excerpts from ARTEP 71-2 (DRAFT) for TOW Squad-Levels 1, 2, and 3. The following are level 2 and 3 training and evaluation outlines.

UNIT: ANTITANK SQUAD (TOW)

MISSION: PROVIDE ANTTANK
FIRE SUPPORT

| TASK | CONDITIONS | TRAINING/EVALUATION STANDARDS |
|----------------------------------------------|--------------------------------------------------------------------------------------------------------------------------------------------------------------------------------------------------------------------------------------------------------------------------------------------------------------------------------------------------------------------------|-------------------------------------------------------------------------------------------------------------------------------------------------------------------------------------------------------------------------------------------------------------------------------------|
| Occupy primary position. | During daylight. The position has been previously reconnoitered by the squad/section leader. | The section is prepared to fire within 30 seconds after arrival at the designated position (time starts when first carrier halts in position and stops when all squads are ready to fire). Squad/section improves the position (e.g., camouflage, security, individual protection). |
| Prepare squad range cards/section fire plan. | During daylight, after arrival at position. | The range card/fire plan must include the location of the TOW, primary sector of fire, all target reference points within the primary sector of fire, dead-space and maximum range line. |
| Identify armored vehicles. | Gunners and assistant gunners will use TOW sight. During test, 1/35 scale model armored vehicles (both friendly and enemy) will be placed hull down, 86 meters to the front of the firing position. During the test, 10 models should be placed out. The evaluator should expose each tank for 10 seconds to allow the gunner to identify the tank and write the answer. | The gunners and assistant gunners will visually identify the vehicles and write the designation or name of the vehicle on the answer sheet. The gunners and assistant gunners must correctly identify 9 out of the 10 vehicles presented. |
| Engage targets with the training equipment. | During daylight. Number of firings: gunner, 2; assistant gunner, 1. Mode: quality. Fired from primary carrier. Low rate. Tracking range: 5 milliradians/second. Blast simulators: 1. Rapid fire: on. New missile simulation sounds loaded for each engagement. | Target is engaged to the 10th second minute (time starts when gunner pulls trigger for first engagement and ends when horn sounds at end of second minute). Missile launch height is higher than 100 meters. Launch excursion is less than 100 meters of zero. |

**COPY AVAILABLE TO DDC DOES NOT
PERMIT FULLY LEGIBLE PRODUCTION**

APPENDIX 3. Excerpts from ARTEP 71-2 (DRAFT) . . . and evaluation outlines. (Cont)

| UNIT: <u>ANTITANK SQUAD (TOW)</u> | | MISSION: <u>PROVIDE ANTITANK FIRE SUPPORT</u> |
|---------------------------------------------|----------------------------------------------------------------------------------------------------------------------------------------------------------------------------------------------------------------------------------------------------------------|---------------------------------------------------------------------------------------------------------------------------------------------------------------------------------------------------------------------------------------------------------------------------------------|
| TASK | CONDITIONS | TRAINING/EVALUATION STANDARDS |
| Engage targets with the training equipment. | During daylight. Number of firings: gunner, 2; assistant gunner, 1. Mode: qualify. Fired from primary carrier. High rate. 15 milliradians/second. Blast simulators: 3. Rapid fire: on. New missile simulation round loaded for each engagement. | Target is engaged twice within 45 seconds (time starts when gunner presses trigger for first engagement and ends when horn sounds at end of second simulated missile impact). Score of 75 or higher is obtained on each engagement. Launch excursions are considered a score of zero. |
| Engage targets with the training equipment. | During daylight. Number of firings: gunner, 2; assistant gunner, 1. Mode: qualify. Fired from primary carrier. High rate. Tracking rate: 25 milliradians/second. Blast simulators: 3. Rapid fire: on. New missile simulation round loaded for each engagement. | Target is engaged twice within 45 seconds (time starts when gunner presses trigger for first engagement and ends when horn sounds at end of second simulated missile impact). Score of 55 or higher is obtained on each engagement. Launch excursions are considered a score of zero. |
| Engage targets with the training equipment. | During hours of darkness. Number of firings: gunner, 2; assistant gunner, 1. Fired from primary carrier. Low rate. Tracking rate: 5 milliradians/second. Blast simulators: 3. Rapid fire: on. New missile simulation round loaded for each engagement. | Target is engaged twice within 60 seconds (time starts when gunner presses trigger for first engagement and ends when horn sounds at end of second simulated missile impact). Score of 55 or higher is obtained on each engagement. Launch excursions are considered a score of zero. |
| Engage targets with the training equipment. | During hours of darkness. Number of firings: gunner, 2; assistant gunner, 1. Fired from primary carrier. High rate. Tracking rate: 15 milliradians/second. | Target is engaged twice within 45 seconds (time starts when gunner presses trigger for first engagement and ends when horn sounds at end of second simulated missile impact). Score of 75 or higher is obtained on each engagement. Launch excursions are considered a score of zero. |

**COPY AVAILABLE TO DGC DOES NOT
PERMIT FULLY LEGIBLE PRODUCTION**

APPENDIX 3. Excerpts from ARTEP 71-2 (DRAFT) . . . and evaluation outlines. (Cont)

UNIT: ANTITANK SQUAD (TOW)

MISSION: PROVIDE ANTI-TANK FIRE SUPPORT

| ID#/TASK | CONDITIONS | TRAINING/EVALUATION STANDARD |
|----------|-----------------------------------------------------------------------------------------------------|------------------------------|
| | Blast simulators, Rapid fire: on. 3. New missile simulation round loaded for each engagement. | |

*To receive a satisfactory rating, the squad must meet or exceed the training/standards on 10 of the 15 firings.

In addition to the tasks and standards listed above, the following task and associated standard is added for the TOW squad/section level 1 evaluation:

ANTITANK SQUAD/SECTION/PLATOON

UNIT: (TOW)

MISSION: PROVIDE ANTI-TANK FIRE S.

| ID#/TASK | CONDITIONS | TRAINING/EVALUATION STANDARD |
|-----------------------------------------|--------------------------------------------------------------------------------------------------------------------------------------------------------------------------------------------------------------------------------------------------------------------------------------------------------------------------------------------------|-------------------------------------------------------------------------------------------------------------------------------------------------------------------------------------------------------------------------------------------------------------------------------------------------------------------------------------------------------------------------------------------------------------------------------------------------------------------------------------------------------------------------------------------------------------------------------------------------------------------------------------------------------------------------------------------------------------------------------------------------------------------------------------------------|
| Prepare and occupy defensive positions. | During daylight. The squad/platoon is located in an assembly area in vicinity of the defensive position. The evaluator takes the leader forward and shows him the limits of the defensive sector and issues him an oral defense order which includes the time the squad/platoon must be prepared to defend and the enemy and friendly situation. | Selection of enemy armor avenues of approach. Armor avenues of approach are properly identified. Primary, alternate and supplementary positions. Sufficient positions are designated to adequately cover the armor avenue(s) of approach. Covered and concealed routes between positions are selected. Camouflage and concealment. From the last covered and concealed position along the most likely armor avenue of approach, one evaluator without binoculars or special equipment and within a short period of time cannot identify any of the squad/platoon firing positions and/or vehicles. Each section is prepared to fire within 30 seconds after arrival at the designated position (time starts when first carrier halts in position and stops when both squads are ready to fire). |

COPY AVAILABLE TO DDC DOES NOT PERMIT FULLY LEGIBLE PRODUCTION

Appendix 4. Proposed Level 3 Training and Evaluation Outline.

Unit: Antitank Squad (TOW)

Mission: Provide Antitank Fire Support

| TASK | CONDITIONS | TRAINING/EVALUATION STANDARDS |
|----------------------------------------------|------------------------------------------------------------------------------------------------------------------------------------------------------------------------------------------------------------------------------------------------------------------|---------------------------------------------------------------------------------------------------------------------------------------------------------------------------------------------------------------------------------------------------------------------------------------|
| 1. Conduct crew drill. | During daylight. Given an APC/TOW and M70 training set at a suitable location to conduct tracking. | The squad places the APC/TOW into action in accordance with TC23-23. A preoperational check and launcher self-test is conducted to insure the system is operational IAW TM9-1425-470-12. The M70 training set is placed into operation in accordance with TM9-6920-470-12. |
| 2. Describe the TOW backblast area. | With the TOW prepared for firing. | Each crew member verbally describes and points out on the ground the danger zone and the caution zone. |
| 3. Describe the TOW misfire procedures. | With the TOW prepared for firing and a missile simulation round loaded in the launch tube. | The squad leader, gunner, and assistant gunner each demonstrate the misfire procedures as specified in para 3-7, TC 23-23 dtd July 1970. |
| 4. Engage targets with the M70 training set. | During daylight. Number of sequences: gunner, 2; assistant gunner, 1. Mode: qualify. Fired from primary carrier. Low rate. Tracking range: 5 milliradians/second. Blast simulators: 6. Rapid fire: on. New missile simulations round loaded for each engagement. | Target is engaged twice within one minute (time starts when gunner presses trigger for first engagement and ends when horn sounds at end of second simulated missile impact). Score of 55 or higher is obtained on each engagement. Launch excursions are considered a score of zero. |

Appendix 4. Proposed Level 3 Training and Evaluation Outline. (Cont)

| TASK | CONDITIONS | TRAINING/EVALUATION STANDARDS |
|-----------------------------------------------------------------------------------|------------------------------------------------------------------------------------------------------------------------------------------------------------------------------------------------------------------------------------------------------------------------------|----------------------------------------------------------------------------------------------------------------------------------------------------------------------------------------------------------------------------------------------------------------------------------------------|
| <p>5. Engage targets with M70 training set.</p> | <p>During daylight. Number of sequences: gunner, 2; assistant gunner, 1. Mode: qualify. Fired from primary carrier. High rate. 15 milliradians/second. Blast simulators: 6. Rapid fire: on. New missile simulation round loaded for each engagement.</p> | <p>Target is engaged twice within 45 seconds (time starts when gunner presses trigger for first engagement and ends when horn sounds at end of second simulated missile impact). Score of 75 or higher is obtained on each engagement. Launch excursions are considered a score of zero.</p> |
| <p>6. Engage targets with the M70 training set.</p> | <p>During daylight. Number of sequences: gunner, 2; assistant gunner, 1. Mode: qualify. Fired from primary carrier. High rate. Tracking rate: 25 milliradians/second. Blast simulators: 6. Rapid fire: on. New missile simulation round loaded for each engagement.</p> | <p>Target is engaged twice within 45 seconds (time starts when gunner presses trigger for first engagement and ends when horn sounds at end of second simulated missile impact). Score of 55 or higher is obtained on each engagement. Launch excursions are considered a score of zero.</p> |
| <p>7. Engage targets moving from one covered position to another using MILES.</p> | <p>During daylight. Number of sequences: gunner, 2; assistant gunner, 1. Target tank in range band 2000-3000m from TOW moves from one covered position to another in 41 seconds. (Target tank first appears at different locations each time.) TOW and tank are equipped</p> | <p>TOW pairs the target continuously for 13 seconds.</p> |

Appendix 4. Proposed Level 3 Training and Evaluation Outline. (Cont)

| TASK | CONDITIONS | TRAINING/EVALUATION STANDARDS |
|-----------------------------------------------------------------------------------|--------------------------------------------------------------------------------------------------------------------------------------------------------------------------------------------------------------------------------------------------------------------------------------------------------------------------------------------------------------------------------------------------------------------------------------------------------------------------------------------------------------------------------------------------------------------------------------------------------------------------------------------------------------------------------------------------------------------------------------------------------------------------------------------------|----------------------------------------------------------|
| <p>8. Engage targets moving from one covered position to another using MILES.</p> | <p>with MILES. TOW laser is in "continuous fire" mode. Radio transmitter is taped to continuously transmit and placed next to kill indicator assembly on tank. Radio at TOW position on same frequency as target and picks up intermittent tone when pairing occurs. Interval between target appearances is 80 seconds. During daylight. Number of sequences: gunner 2; assistant gunner, 1. Target tank in range band 1500-2500m from TOW moves from one covered position to another in 38 seconds. (Target tank first appears at different location each time). TOW and tank are equipped with MILES. TOW laser is in "continuous fire" mode. Radio on target tank is set to transmit intermittent tone to the TOW when pairing occurs. Interval between target appearances is 80 seconds.</p> | <p>TOW pairs the target continuously for 10 seconds.</p> |
| <p>9. Engage targets moving from one covered position to another using MILES.</p> | <p>TOW moves from one covered position to another in 33 seconds (target tank first appears at different</p> | <p>TOW pairs the target continuously for 5 seconds.</p> |

Appendix 4. Proposed Level 3 Training and Evaluation Outline. (Cont)

| TASK | CONDITIONS | TRAINING/EVALUATION STANDARDS |
|--------------------------------------------------------------------------|----------------------------------------------------------------------------------------------------------------------------------------------------------------------------------------------------------------------------------------------------------------------------------------------------------------------------------------------------------------------------------------------------------------------------------------------------------------------------------------------------------------------------------------------------------------------------------------------------------|----------------------------------------------------------|
| <p>10. Engage targets performing hard evasive maneuvers using MILES.</p> | <p>location each time.) TOW and tank are equipped with MILES. TOW laser is in "continuous fire" mode. Radio on target tank is set to transmit intermittent tone to the TOW when pairing occurs. Interval between target appearances is 80 seconds.</p> <p>During daylight. Number of sequences: Gunner 2, assistant gunner, 1. Target tank in range band 2000-3000m from TOW performs hard evasive maneuvers for 30 seconds. TOW and tank are equipped with MILES. TOW laser is in "continuous fire" mode. Radio on target tank is set to transmit intermittent tone to the TOW when pairing occurs.</p> | <p>TOW pairs the target continuously for 13 seconds.</p> |
| <p>11. Engage targets performing hard evasive maneuvers using MILES.</p> | <p>During daylight. Number of firings: gunner 2, assistant gunner, 1. Target tank in range band 1500-2500m from TOW performs hard evasive maneuvers for 30 seconds. TOW and tank are equipped with MILES. TOW laser is in "continuous fire" mode. Radio on target tank is set to transmit intermittent tone to the TOW when pairing occurs.</p> | <p>TOW pairs the target continuously for 10 seconds.</p> |

Appendix 4. Proposed Level 3 Training and Evaluation Outline. (Cont)

| TASK | CONDITIONS | TRAINING/EVALUATION STANDARDS |
|--------------------------------------------------------------------------|------------------------------------------------------------------------------------------------------------------------------------------------------------------------------------------------------------------------------------------------------------------------------------------------------------------------------------------------|----------------------------------------------------------------------------------------------------------------------------------------------------------------------------------------------------------------------------------------------------------------------------------------------|
| <p>12. Engage targets performing hard evasive maneuvers using MILES.</p> | <p>During daylight. Number of firings: gunner 2, assistant gunner, 1. Target tank in range band 500-1500m from TOW performs hard evasive maneuvers for 15 seconds. TOW and tank are equipped with MILES. TOW laser is in "continuous fire" mode. Radio on target tank is set to transmit intermittent tone to the TOW when pairing occurs.</p> | <p>TOW pairs the target continuously for 5 seconds.</p> |
| <p>13. Engage targets with the M70 training set.</p> | <p>During hours of darkness using the TOW night sight. Number of sequences: gunner, 2; assistant gunner, 1. Fired from primary carrier. Low rate. Tracking rate: 5 milliradians/second. Blast simulators: 6. Rapid fire: on. New missile simulation round loaded for each engagement.</p> | <p>Target is engaged twice within 60 seconds (time starts when gunner presses trigger for first engagement and ends when horn sounds at end of second simulated missile impact). Score of 55 or higher is obtained on each engagement. Launch excursions are considered a score of zero.</p> |
| <p>14. Engage targets with the M70 training set.</p> | <p>During hours of darkness using the TOW night sight. Number of sequences: gunner, 2; assistant gunner, 1. Fired from primary carrier. High rate. Tracking range: 15 milliradians/second. Blast simulators, 6. Rapid fire: on. New missile simulation round loaded for each engagement.</p> | <p>Target is engaged twice within 45 seconds (time starts when gunner presses trigger for first engagement and ends when horn sounds at end of second simulated missile impact). Score of 75 or higher is obtained on each engagement. Launch excursions are considered a score of zero.</p> |

Appendix 4. Proposed Level 3 Training and Evaluation Outline. (Cont)

| TASK | CONDITIONS | TRAINING/EVALUATION STANDARDS |
|-----------------------------------------------|----------------------------------------------------------------------------------------------------------------------------------------------------------------------------------------------------------------------------------------------------------------------------------------------------------------------------------------------------------------------------------------------------------------------------------------------------------|----------------------------------------------------------|
| <p>15. Engage moving targets using MILES.</p> | <p>During hours of darkness using the TOW night sight. Number of sequences: gunner 2, assistant gunner, 1. Target tank in range band 2000-3000m from TOW; moving diagonally with respect to the TOW and at a speed of 15 mi/hr (6.7 m/s). TOW and tank are equipped with MILES. TOW laser is in "continuous fire" mode. Radio on target tank is set to transmit intermittent tone to the TOW when pairing occurs. Each sequence is 41 seconds long.</p> | <p>TOW pairs the target continuously for 13 seconds.</p> |
| <p>16. Engage moving targets using MILES.</p> | <p>During hours of darkness using the TOW night sight. Number of sequences: gunner, 2, assistant gunner, 1. Target tank in range band 1500-2500m from TOW; moving diagonally with respect to the TOW and at a speed of 15 mi/hr (6.7 m/s). TOW and tank are equipped with MILES. TOW laser is in "continuous fire" mode. Radio on target tank is set to transmit intermittent tone to the TOW when pairing occurs. Each sequence is 38 seconds long.</p> | <p>TOW pairs the target continuously for 10 seconds.</p> |

Appendix 4. Proposed Level 3 Training and Evaluation Outline. (Cont)

| TASK | CONDITIONS | TRAINING/EVALUATION STANDARDS |
|-----------------------------------------------------------------------------------------|-------------------------------------------------------------------------------------------------------------------------------------------------------------------------------------------------------------------------------------------------------------------------------------------------------------------------------------------------------------------------------------------------------------------------------------------------------|----------------------------------------------------------------------------------------------------------------------------------------------------------------------------------------------------------------------------------------------------------------------------------------------|
| <p>17. Engage moving targets using MILES.</p> | <p>During hours of darkness using the TOW night sight. Number of sequences: Gunner 2, assistant gunner, 1. Target tank in range band 500-1500m from TOW; moving diagonally with respect to the TOW and at a speed of 15 mi/hr (6.7 m/s). TOW and tank are equipped with MILES TOW laser is in "continuous fire" mode. Radio on target tank is set to transmit intermittent tone to the TOW when pairing occurs. Each sequence is 33 seconds long.</p> | <p>TOW pairs the target continuously for 5 seconds.</p> |
| <p>18. In a chemical warfare environment, engage targets with the M70 training set.</p> | <p>During daylight while wearing the chemical protective mask and protective clothing. Number of sequences: Gunner, 2; assistant gunner, 1. Mode: qualify. Fired from primary carrier. Low rate. Tracking range: 5 milliradians/second. Blast simulators: 6. Rapid fire: on. New missile simulation round loaded for each engagement.</p> | <p>Target is engaged twice within one minute (time starts when gunner presses trigger for first engagement and ends when horn sounds at end of second simulated missile impact). Score of 55 or higher is obtained on each engagement. Launch excursions are considered a score of zero.</p> |

Appendix 4. Proposed Level 3 Training and Evaluation Outline. (Cont)

| TASK | CONDITIONS | TRAINING/EVALUATION STANDARDS |
|----------------------------------------------------------------------------------|-------------------------------------------------------------------------------------------------------------------------------------------------------------------------------------------------------------------------------------------------------------------------------------------------------------------------------------------------------------------|---------------------------------------------------------------------------------------------------------------------------------------------------------------------------------------------------------------------------------------------------------------------------------------|
| 19. In a chemical warfare environment, engage targets with the M70 training set. | During daylight while wearing the chemical protective mask and protective clothing. Number of sequences: Gunner, 2; assistant gunner, 1. Mode: qualify. Fired from primary carrier. High rate. Tracking range: 15 milliradians/second. Blast simulators: 6. Rapid fire: on. New missile simulation round loaded for each engagement. | Target is engaged twice within 45 seconds (time starts when gunner presses trigger for first engagement and ends when horn sounds at end of second simulated missile impact). Score of 75 or higher is obtained on each engagement. Launch excursions are considered a score of zero. |
| 20. In a chemical warfare environment, engage targets with the M70 training set. | During the hours of darkness while wearing the chemical protective mask and protective clothing, and using the TOW night sight. Number of sequences: Gunner, 2; assistant gunner, 1. Fired from primary carrier. Low rate. Tracking rate: 5 milliradians/second. Blast simulators: 6. Rapid fire: on. New missile simulation round loaded for each engagement. | Target is engaged twice within 60 seconds (time starts when gunner presses trigger for first engagement and ends when horn sounds at end of second simulated missile impact). Score of 55 or higher is obtained on each engagement. Launch excursions are considered a score of zero. |
| 21. In a chemical warfare environment, engage targets with the M70 training set. | During the hours of darkness while wearing the chemical protective mask and protective clothing, and using the TOW night sight. Number of sequences: Gunner, 2; assistant gunner, 1. Fired from primary carrier. High rate. Tracking range: 15 milliradians/second. Blast simulators: 6. Rapid fire: on. New missile simulation round loaded for each engagement. | Target is engaged twice within 45 seconds (time starts when gunner presses trigger for first engagement and ends when horn sounds at end of second simulated missile impact). Score of 75 or higher is obtained on each engagement. Launch excursions are considered a score of zero. |

Appendix 4. Proposed Level 3 Training and Evaluation Outline. (Cont)

| TASK | CONDITIONS | TRAINING/EVALUATION STANDARDS |
|-------------------------------------------------------------------------------------------------------------------------------------------|-----------------------------------------------------------------------------------------------------------------------------------------------------------------------------------------------------------------------------------------------------------------------------------------------------------------------------------------------------------------------------------------------------------------------------------------------------------------------------------------------------------------------------------------------------------------------------------------------------------------------------------------------------------------------------------------------------------------------------------------------------------------------------------------------------------------------|----------------------------------------------------------|
| <p>22. When suppressed by simulated artillery fire and smoke, engage targets moving from one covered position to another using MILES.</p> | <p>simulators, 6. Rapid fire: on. New simulation round loaded for each engagement.</p> <p>During daylight. Number of sequences: gunner, 2; assistant gunner, 1. Target tank in range band 1500-2500m from TOW moves from one covered position to another in 38 seconds (target tank first appears at different location each time). TOW and tank are equipped with MILES. TOW laser is in "continuous fire" mode. Radio on target is set to transmit intermittent tone to the TOW when pairing occurs. Interval between target appearances is 80 seconds. Artillery blast simulators are exploded 15-30m on a 45° arc in front of the TOW. One artillery simulator is exploded every 6 seconds per 38 second sequence. Two white smoke grenades per sequence are ignited 100m apart and 100m in front of the TOW.</p> | <p>TOW pairs the target continuously for 10 seconds.</p> |
| <p>23. When suppressed by simulated artillery fire and smoke, engage moving targets using MILES.</p> | <p>During hours of darkness using the TOW night sight. Number of sequences: gunner, 2; assistant gunner, 1. Target tank in range band 500-1500m from TOW; moving diagonally with respect to the TOW and at a speed of 15 mi/hr (6.7 m/s).</p> | <p>TOW pairs the target continuously for 5 seconds.</p> |

Appendix 4. Proposed Level 3 Training and Evaluation Outline. (Cont)

| TASK | CONDITIONS | TRAINING/EVALUATION STANDARDS |
|-----------------------------------------------------------------------------------|------------------------------------------------------------------------------------------------------------------------------------------------------------------------------------------------------------------------------------------------------------------------------------------------------------------------------------------------------------------------------------------------------------------------------------------------------------------------------------------------------------------------------------|------------------------------------------------------------------------------------------------------------------------------------------------------------------------------------------------------------------------------------------------------------------------------------------------------------------------------|
| <p>24. Describe and perform operator maintenance on the TOW and the M113 APC.</p> | <p>TOW and tank are equipped with MILES. TOW laser is in "continuous fire" mode. Radio on target tank is set to transmit intermittent tone to the TOW when pairing occurs. Each sequence is 33 seconds long. Artillery blast simulators are exploded 15-30m on a 45° arc in front of the TOW. One artillery simulator is exploded every 5 seconds per 33 second sequence. Two white smoke grenades per sequence are ignited 100m apart and 100m in front of the TOW.</p> <p>With the TOW and M113 APC at the testing location.</p> | <p>The squad leader, Gunner and assistant Gunner describe and demonstrate TOW crew maintenance checks. The squad leader and APC driver describe and demonstrate M113 APC before, during, and after operation checks. Squad performs appropriate TOW and M113 APC maintenance throughout the duration of the ARTEP tests.</p> |

For M70 training set and MILES TOW tracking sequences 48 of the 60 sequences must be satisfactorily accomplished.

Appendix 5. Proposed Level 2 Training and Evaluation Outline. (To be proficient at Level 2, the TOW section must be proficient in the Level 3 tasks in addition to the Level 2 tasks listed below.)

| UNIT: ANTITANK SECTION (TOW) | MISSION: PROVIDE ANTITANK FIRE SUPPORT | TRAINING/EVALUATION STANDARDS |
|---------------------------------------------------------------------------------------------|--------------------------------------------------------------------------------------------------------------------------------------------------------------------------------------------------------------------------------------------------------------------------------------------------------------------------------------------------------------------------------------------------------------------------------------------------------------------------------------------------------------------------------|--------------------------------------------------------------------------------------------------------------------------------------------------------------------------------------------------------------------------------------------------------------------------------------------------------------------------------------------------------------------------------------------------|
| TASK | CONDITIONS | TRAINING/EVALUATION STANDARDS |
| <p>1. Reconnoiter and select exact firing positions and routes to the firing positions.</p> | <p>During daylight. The section is located in an assembly area in vicinity of the defensive position. The evaluator takes the section leader and the TOW squad leader to a vantage point overlooking the battle area. The evaluator issues an oral defensive order to include the enemy and friendly situation, TOW section primary sector of fire, secondary sector of fire, target reference points, general location of firing positions, and time the section is to be ready to defend. Defensive sector is 500m wide.</p> | <p>Section leader and TOW squad leader select enemy avenue(s) of armor approach; primary, alternate, and supplementary positions; routes to positions, and routes between positions. All routes are reconnoitered. At least 3 positions are selected to adequately cover the sector of fire and if required nightfiring positions are selected.</p> |
| <p>2. Prepare the firing positions.</p> | <p>During daylight. In a company primary defensive position each squad prepares at least 3 positions, one of which is in hull defilade or the gun is dismounted and dug-in. Positions are all within a 500m defensive sector.</p> | <p>With each TOW squad occupying the hull defilade positions, the position is checked using MILES. A tank (or APC TOW) is positioned 1500m from the position. The gunner using the main gun sight and the tank commander with binoculars attempt to locate the TOW position. The tank crew has 3 minutes and one opportunity to locate and pinpoint the TOW position. Pinpoint is checked by</p> |

Appendix 5. Proposed Level 2 Training and Evaluation Outline. (Cont)

UNIT: ANTITANK SECTION (TOW) MISSION: PROVIDE ANTITANK FIRE SUPPORT

| TASK | CONDITIONS | TRAINING/EVALUATION STANDARDS |
|-------------------------------------------------------------------------|-------------------------------------------------------------------------------------------------------------------------------------------------------------------------------------------------------------------------------------------------------------------------------------------------------------|-------------------------------------------------------------------------------------------------------------------------------------------------------------------------------------------------------------------------------------------------------------------------------------------------------------------------------------------------------------------------------------------------------------|
| <p>3. Provide for mutual support and security at primary positions.</p> | <p>During daylight. Each TOW squad is in its primary position. Three stationary tanks with MILES (or APC with MILES) are located at least 700m apart within the primary sector of fire. Each TOW engages the target tanks with their laser transmitter in the "continuous fire" mode.</p> | <p>firing the tank laser transmitter in the "continuous fire" mode at the suspected defensive position. If a laser pairing occurs, the TOW squad fails the task.</p> <p>Each TOW squad pairs each tank for 5 seconds. Squad leaders verbally describe how they would achieve mutual support with adjacent anti-tank weapons and how they would integrate the security of the TOW crew with local units.</p> |
| <p>4. Provide for mutual support at alternate positions.</p> | <p>During daylight. Evaluator positions each TOW squad in an alternate position selected by him; 3 stationary tanks with MILES (or APC with MILES) are located at least 700m apart within the primary sector of fire. Each TOW engages the target tanks with their laser in the "continuous fire" mode.</p> | <p>Each TOW squad pairs each tank for 5 seconds.</p> |
| <p>5. Prepare firing list.</p> | <p>During daylight. As soon as possible after occupation of firing positions, the section leader submits to the evaluator a firing list.</p> | <p>Firing list includes: Unit designation; location of firing positions to include primary, alternate (day and night), and supplementary positions; target reference points covered from primary and alternate positions; and target reference</p> |

Appendix 5. Proposed Level 2 Training and Evaluation Outline. (Cont)

UNIT: ANTITANK SECTION (TOW) MISSION: PROVIDE ANTITANK FIRE SUPPORT

| TASK | CONDITIONS | TRAINING/EVALUATION STANDARDS |
|-------------------------------------------------------------------------------------|---------------------------------------------------------------------------------------------------------------------------------------------------------------------------------------------------------------------------------------------------------------------------------------------------------------------------------------------------------------------------------------------------------------------------------------------------------------------------------------------------------------------------------------------------------------------|--------------------------------------------------------------------------------------------------------------------------------------------------------------------------------------------------------------------------------------------------------------------------------------------------------------------------------------------------------------------------------------------------------------------|
| 6. Prepare range cards. | During daylight after arrival at position. A squad range card is given to the evaluator for each firing position. | points covered from supplementary positions. Each squad range card includes pre-pairing unit and date, sector of fire, maximum range line, deadspace weapons position, target reference points, and intervisibility segments. MILES with TOW laser in "continuous fire" mode and a target vehicle down range is used to check deadspace, coverage around target reference points, and intervisibility segments. |
| 7. From primary positions, control fires to insure efficient engagement of targets. | During daylight. Number of sequences: gunner, 2; assistant gunner, 1. With each TOW squad equipped with MILES and in their primary firing position. A simulated threat of 4-6 tanks and 2-4 APC (equipped with MILES) approach in a line formation and 50m apart. With the TOWs in the "continuous fire" mode. Evaluator directs the section leader to use the FRONTAL pattern of fire. Target tank/APC commanders (TC) time pairing duration. After pairing time corresponding to TOW flight time for that range, TC raises a red flag and stops the tank. The TOW | TOW section leader and squad leader issue the proper fire commands, targets are engaged from flanks to center in proper priorities (Tanks first then APC). |

Appendix 5. Proposed Level 2 Training and Evaluation Outline. (Cont)
 UNIT: ANTTANK SECTION (TOW) MISSION: PROVIDE ANTTANK FIRE SUPPORT

| TASK | CONDITIONS | TRAINING/EVALUATION STANDARDS |
|---------------------------------------------------------------------------------------------------------------|--------------------------------------------------------------------------------------------------------------------------------------------------------------------------------------------------------------------------------------------------------------------------------------------------------------------------------------------------------------------------------------------------------------------------------------------------------------------------------------------------------------------------------------------------------------------------------------------------------------------------------------------------------------------------------------------------------------------------------------------------|--------------------------------------------------------------------------------------------------------------------------------------------------------------------------------------------------------------------------------------------------------------------------------------------------------------------------------------------------------------|
| <p>8. TOW squads move to alternate positions and control fires to insure efficient engagement of targets.</p> | <p>squad then engages another target vehicle.</p> <p>During daylight. Number of sequences: gunner, 2; assistant gunner, 1. On order from the section leader each TOW squad moves from primary firing position to alternate firing position. While at the alternate firing position, a simulated threat of 4-6 tanks and 2-4 APC (equipped with MILES) approach in a line formation and 50m apart. With the TOWs in the "continuous fire" mode. Evaluator directs the section leader to use the CROSS pattern of fire, target tank/APC commanders (TC) time pairing duration. After pairing time corresponding to TOW flight time for that range, TC raises a red flag and stops the tank. The TOW squad then engages another target vehicle.</p> | <p>TOW section moves to alternate positions in a responsive manner over covered and concealed routes. TOW squads are prepared to fire within 30 seconds after arrival in position. TOW section leader and squad leader issue the proper fire commands, targets are engaged from far flank toward the center in proper priorities (Tanks first then APC).</p> |

Appendix 5. Proposed Level 2 Training and Evaluation Outline. (Cont)

| UNIT: ANTI-TANK SECTION (TOW) | MISSION: PROVIDE ANTI-TANK FIRE SUPPORT | TRAINING/EVALUATION STANDARDS |
|---------------------------------------------------------------------------------------------------------------|--------------------------------------------------------------------------------------------------------------------------------------------------------------------------------------------------------------------------------------------------------------------------------------------------------------------------------------------------------------------------------------------------------------------------------------------------------------------------------------------------------------------------------------------------------------------------------------------------------------------------------------------------------------------------------------------------------------|----------------------------------------------------------------------------------------------------------------------------------------------------------------------------------------------------------------------------------------------------------------------------------------------------------------------------------------------------------------------------|
| TASK | CONDITIONS | |
| <p>9. TOW squads move to alternate positions and control fires to insure efficient engagement of targets.</p> | <p>During daylight. Number of sequences: gunner, 2; assistant gunner, 1. On order from the section leader each TOW squad moves from the previously occupied position to an alternate firing position. While at the alternate firing position, a simulated threat of 4-6 tanks and 2-4 APC (equipped with MILES) approach in a column formation and 50m apart. With the TOWs in the "continuous fire" mode. Evaluator directs the section leader to use the DEPTH pattern of fire. Target tank/APC commanders (TC) time pairing duration. After pairing time corresponding to TOW flight time for that range, IC raises a red flag and stops the tank. The TOW squad then engages another target vehicle.</p> | <p>TOW section moves to alternate positions in a responsive manner over covered and concealed routes. TOW squads are prepared to fire within 30 seconds after arrival in position. TOW section leader and squad leader issue the proper fire commands, targets are engaged from head and tail of column toward the center in proper priorities (tanks first then APC).</p> |
| <p>10. From primary positions, control fires to insure efficient engagement of targets.</p> | <p>During hours of darkness using the TOW night sight. Number of sequences: gunner, 2; assistant gunner, 1. With each TOW squad equipped with MILES and in their primary firing position. A simulated threat of 4-6 tanks and 2-4 APC</p> | <p>TOW section leader and squad leader issue the proper fire commands, targets are engaged from flanks to center in proper priorities (tanks first then APC).</p> |

Appendix 5. Proposed Level 2 Training and Evaluation Outline. (Cont)

UNIT: ANTTANK SECTION (TOW) MISSION: PROVIDE ANTTANK FIRE SUPPORT TRAINING/EVALUATION STANDARDS

| TASK | CONDITIONS | |
|----------------------------------------------------------------------------------------------------------------|------------------------------------------------------------------------------------------------------------------------------------------------------------------------------------------------------------------------------------------------------------------------------------------------------------------------------------------------------------------------------------------------------------------------------------------------------------------------------------------------------------------------------------------------------|-------------------------------------------------------------------------------------------------------------------------------------------------------------------------------------------------------------------------------------------------------------------------------------------------------------------------------------------------------------|
| <p>11. TOW squads move to alternate positions and control fires to insure efficient engagement of targets.</p> | <p>(equipped with MILES) approach in a line formation and 50m apart. With the TOWs in the "continuous fire" mode. Evaluator directs the section leader to use the FRONTAL pattern of fire. Target tank/APC commanders (TC) time pairing duration. After pairing time corresponding to TOW flight time for that range, TC turns on headlights and stops the tank. The TOW squad then engages another target vehicle. TOW squads may perform task at alternate night position, if the sector cannot be covered at night from the primary position.</p> | |
| | <p>During hours of darkness using the TOW night sight. Number of sequences: gunner, 2; assistant gunner, 1. On order from the section leader each TOW squad moves from primary firing position to alternate firing position. While at the alternate firing position, a simulated threat of 4-6 tanks and 2-4 APC (Equipped with MILES) approach in a line formation and 50m apart. With the TOWs in the "continuous fire"</p> | <p>TOW section moves to alternate positions in a responsive manner over covered and concealed routes. TOW squads are prepared to fire within 30 seconds after arrival in position. TOW section leader and squad leader issue the proper fire commands, targets are engaged from far flank toward the center in proper priorities (Tanks first then APC)</p> |

Appendix 5. Proposed Level 2 Training and Evaluation Outline. (Cont)

| UNIT: ANTITANK SECTION (TOW) | MISSION: PROVIDE ANTITANK FIRE SUPPORT | TRAINING/EVALUATION STANDARDS |
|----------------------------------------------------------------------------------------------------------------|----------------------------------------------------------------------------------------------------------------------------------------------------------------------------------------------------------------------------------------------------------------------------------------------------------------|----------------------------------------------------------------------------------------------------------------------------------------------------------------------------------------------------------------------------------------------------------------------------------------------------------------------------------------------------------------------------|
| TASK | CONDITIONS | |
| <p>12. TOW squads move to alternate positions and control fires to insure efficient engagement of targets.</p> | <p>mode. Evaluator directs the section leader to use the CROSS pattern of fire. Target tank/APC commanders (TC) time pairing duration. After a pairing time corresponding to TOW flight time for that range, TC turns on headlights and stops the tank. The TOW squad then engages another target vehicle.</p> | <p>TOW section moves to alternate positions in a responsive manner over covered and concealed routes. TOW squads are prepared to fire within 30 seconds after arrival in position. TOW section leader and squad leader issue the proper fire commands, targets are engaged from head and tail of column toward the center in proper priorities (tanks first then APC).</p> |

Appendix 5. Proposed Level 2 Training and Evaluation Outline. (Cont)

UNIT: ANTITANK SECTION (TOW) MISSION: PROVIDE ANTITANK FIRE SUPPORT

TRAINING/EVALUATION STANDARDS

CONDITIONS

TASK

squad then engages another target vehicle.

13. Identify armored vehicles.

Gunners and assistant gunners will use TOW sight. During test 1/35 scale model armored vehicles (both friendly and enemy) will be placed hull down, 86 meters to the front of the firing position. During the test, 10 models should be placed out. The evaluator should expose each tank for 10 seconds to allow the gunner to identify the tank and write the answer.

The gunners and assistant gunners will visually identify the vehicles and write the designation or name of the vehicle on the answer sheet. The gunners and assistant gunners must correctly identify 9 out of the 10 vehicles presented.

14. Engage an area target with 81mm mortars.

During daylight. Section leader, squad leader, and gunner engage an area target representing a squad size enemy reconnaissance patrol within 3000m of the observer.

Initial fire request is transmitted to the FDC within 2 minutes of target identification and subsequent adjustments within 30 seconds of impact of adjusting round. Accuracy of observers initial data: 400m or less from target. Effects: at least one round impacts within 50m of the target. Fire for effect within 12 min. of target identification.

15. Adjust 81mm mortar illumination.

During hours of darkness. Section leader, squad leader and gunners call for and adjust illumination over suspected movement.

Initial fire request is transmitted to the FDC within 2 minutes and subsequent adjustments within 30 seconds of illumination round blast. Within 12 minutes of original request, last adjusting round illuminates the target area and burns out just above the ground.

Appendix 5. Proposed Level 2 Training and Evaluation Outline. (Cont)

| UNIT: ANTITANK SECTION (TOW) | MISSION: PROVIDE ANTITANK FIRE SUPPORT | TRAINING/EVALUATION STANDARDS |
|-----------------------------------------------------------------------------|----------------------------------------------------------------------------------------|-----------------------------------------------------------------------------------------------|
| TASK | CONDITIONS | |
| 16. In a chemical warfare environment, decontaminate the TOW and M-113 APC. | Each TOW squad is contaminated (simulated) by a nerve agent and a blister agent. | The TOW and M-113 APC are decontaminated in accordance with procedures described in FM 21-40. |
| 17. Request and coordinate resupply of ammunition. | The evaluator verbally questions the section leader on ammunition resupply procedures. | Section leader and squad leader verbally describe the ammunition resupply procedure. |

For the TOW tracking sequences with MILES, 14 of the 18 sequences must be satisfactorily accomplished. For the adjustment of 81mm mortar high explosive and illumination, one person per TOW squad must satisfactorily accomplish the tasks.

Appendix 6. Proposed Level 1 Training and Evaluation Outline. (To be proficient at Level 1, the TOW section must be proficient in the Level 3 tasks in addition to the Level 1 tasks listed below.)

UNIT: ANTITANK SECTION (TOW) MISSION: PROVIDE ANTITANK FIRE SUPPORT

| TASK | CONDITIONS | TRAINING/EVALUATION STANDARDS |
|--------------------------------------------------------------------------------------|--------------------------------------------------------------------------------------------------------------------------------------------------------------------------------------------------------------------------------------------------------------------------------------------------------------------------------------------------------------------------------------------------------------------------------------------------------------------------------------------------------------------------------------------------------------------------------------------|-----------------------------------------------------------------------------------------------------------------------------------------------------------------------------------------------------------------------------------------------------------|
| 1. Reconnoiter and select exact firing positions and routes to the firing positions. | During daylight. The section is located in an assembly area in vicinity of the defensive position. The evaluator takes the section leader and the TOW squad leader to a vantage point overlooking the battle area. The evaluator issues an oral defensive order to include the enemy and friendly situation, TOW section primary sector of fire, secondary sector of fire, target reference points, general location of firing positions, and time the section is to be ready to defend (section is given 8 daylight hours to prepare defensive positions.) Defensive sector is 500m wide. | Section leader and squad leader select enemy avenues of armor approach; primary, alternate, and supplementary positions; and routes to positions and routes between positions. All routes are reconnoitered. Day and night firing positions are selected. |
| 2. Prepare the firing positions. | During daylight. In a company primary defensive position, TOW squads prepare firing positions. Eight | When possible, hull defilade positions are prepared. TOW is dismounted from APC if necessary. All positions are well camouflaged. |

Appendix 6. Proposed Level 1 Training and Evaluation Outline. (Cont)

UNIT: ANTITANK SECTION (TOW)

MISSION: PROVIDE ANTITANK FIRE SUPPORT

| TASK | CONDITIONS | TRAINING/EVALUATION STANDARDS |
|------------------------------------------------------------|------------------------------------------------------------------------------------------------------------------------------------------------------------------------------------------------------------------------------------------------------------------------------------------------------------------------------------------------------------------------------------------------------------------------------------------------------------------------------------------------------------------------------------------------------------------------------------------------------------------------------------------------------------------------------------------------------------------------------------------------------------------------------------------------------------------------------------------------------|----------------------------------------------------------------------------------------------|
| <p>3. *Defend at a company primary defensive position.</p> | <p>daylight hours are allowed for reconnaissance and preparation of positions. All positions are within a 500m defensive sector. During daylight. Number of sequences: gunner, 2; assist gunner, 1. TOW section and threat are equipped with MILES. A threat force composed of 10 tanks (or TOWs simulating tanks) and 2 BRDM (simulated by TOWs) attacks the defending TOW section using the rapid approach technique. Threat starts 3500m from defenders. No more than two threat tanks and one BRDM will be stationary at any one time. Sequence ends when all threat vehicles are within 200m of the defenders positions (sequence termination line or STL). Threat is required to get as many vehicles as possible to the STL. Each TOW squad is allocated 10 missiles. Threat tanks are allocated 40 rounds each, and 6 missiles per BRDM.</p> | <p>TOW section kills a minimum of 10 threat tanks/APC while losing a maximum of one TOW.</p> |

Appendix 6. Proposed Level 1 Training and Evaluation Outline. (Cont)

UNIT: ANTI-TANK SECTION (TOW)

MISSION: PROVIDE ANTI-TANK FIRE SUPPORT

| TASKS | CONDITIONS | TRAINING/EVALUATION STANDARDS |
|----------------------------------------------------|----------------------------------------------------------------------------------------------------------------------------------------------------------------------------------------------------------------------------------------------------------------------------------------------------------------------------------------------------------------------------|-------------------------------------------------------------------------------------------------------------------------------------------------------------------------------------------------------------------------------------------------------------------------------------------------------------------------------------------------------------------------------------------------------------------------------------------------|
| <p>5. Identify armored vehicles.</p> | <p>Gunners and assistant gunners will use TOW sight. During tests, 1/35 scale model armored vehicles (both friendly and enemy) will be placed hull down, 86m to the front of the firing position. During the test, 10 models should be placed out. The evaluator should expose each tank for 10 seconds to allow the gunner to identify the tank and write the answer.</p> | <p>The gunners and assistant gunners will visually identify and write the designation or name of the vehicle on the answer sheet. The gunners and assistant gunners must correctly identify 9 out of the 10 vehicles presented.</p> |
| <p>6. Engage an area target with 81mm mortars.</p> | <p>During daylight. Section leader, squad leader and gunners, engage an area target representing a squad-size enemy reconnaissance patrol within 3000m of the observer.</p> | <p>Initial fire request is transmitted to the FDC within 2 minutes of target identification and subsequent adjustments within 30 seconds of impact of adjusting round. Accuracy of observer's initial data: 400 m or less from the target. Effects: at least one round impacts within 50m of the target. Fire for effect within 12 minutes of target identification. Two members of each TOW squad must satisfactorily accomplish the task.</p> |
| <p>7. Adjust 81mm mortar illumination.</p> | <p>During hours of darkness. Section leader, squad leader, and gunners call for and adjust illumination over suspected movement.</p> | <p>Initial fire request is transmitted to the FDC within 2 minutes and subsequent adjustments within 30 seconds of illumination round burst. Within 12 minutes of original request, last adjusting round</p> |

Appendix 6. Proposed Level 1 Training and Evaluation Outline. (Cont)

UNIT: ANTITANK SECTION (TOW)

MISSION: PROVIDE ANTITANK FIRE SUPPORT

| TASKS | CONDITIONS | TRAINING/EVALUATION STANDARDS |
|-----------------------------------------------------------------------------------|-----------------------------------------------------------------------------------------|-----------------------------------------------------------------------------------------------------------------------------------------------------------------------------------------------------------------------------------------------------|
| <p>8. In a chemical warfare environment, decontaminate the TOW and M-113 APC.</p> | <p>Each TOW squad is contaminated (simulated) by a nerve agent and a blister agent.</p> | <p>illuminates the target area and burns out just above the ground. Two members of each TOW squad must satisfactorily accomplish the task.</p> <p>The TOW and M-113 APC are decontaminated in accordance with procedures described in FM 21-40.</p> |

Appendix 7: Thoughts on Other Simulations

MILES as a tactical simulator will enable simulation of the majority of the direct fire weapons and missile systems in combat divisions. However, additional research and development is required in the simulations of tactical mine warfare, indirect fire, and laser guided projectiles.

TACTICAL MINE WARFARE

The ability to emplace mines rapidly in the defense and to clear lanes through enemy minefields in the offense, is one of the basic skills which infantrymen and combat engineers must master. There are two basic types of mines--anti-personnel and antitank. Five to ten pounds of pressure will detonate the antipersonnel mine; whereas, several hundred pounds of pressure are required to detonate antitank mines. Other techniques of detonation can also be used, such as trip wires, magnetic detection, electromagnetic devices, etc. Mines are usually employed in clusters consisting of one antitank mine ringed by a number of antipersonnel mines. Minefields can be as long and as wide as the situation dictates and are usually marked.

A simple technique which can be used to simulate the effects of tactical minefields involves the use of dummy mines designed to provide visual cues when a detonation occurs, and a controller equipped with a MILES controller gun to "kill" the personnel/tank in the minefield when the visual cue is seen. Antitank mines can be designed in such a way that pressure on the mine from a tank will cause colored smoke to be emitted from the mine. On seeing the smoke the controller using a controller gun would "kill" the MILES equipped tank. Similarly, antipersonnel mines can be designed to emit a white powder or colored smoke when tripped by personnel. Again the controller on seeing the powder/smoke would "kill" the MILES equipped soldiers with his controller gun.

INDIRECT FIRE

Simulation of the effects of indirect fires on the battlefield would require preparation of the area before the tactical exercise. Preparations would include seeding the area with blast simulators and short range laser transmitters. Blast simulators similar to the Hoffman device (cylindrical holes in a rectangular box which can fire artillery blast effect cartridges or smoke cartridges) can be placed one per 50m square (Figure 17). Blast simulators are placed in holes three feet deep and are surrounded by barbed wire to prevent vehicles or troops from getting too near the hole and risk injury on detonation. The blast simulator is tied to a control console via a telemetry link. Also tied to the blast simulator and protruding above the ground is a short-range wide-angle laser which would "kill" MILES equipped vehicles/personnel within lethal range of the simulated artillery/mortar blast.

A typical indirect fire mission would be called to controllers at the control console by radio. Controllers at the control console would play the role of the FIRE DIRECTION CENTER, acknowledge the call for fire, determine the blast simulator closest to the coordinates requested by the forward observer (FO), and detonate the blast simulator via the telemetry link at the appropriate time. The wide angle laser tied to the blast simulator would emit MILES "kill" words at the time of the blast. With blast simulators seeded throughout the area, simulated indirect fires can be adjusted by the FO, and "fire for effect" can be simulated in the area desired. A crude version of this system was developed by CDEC for the PARFOX experiment in 1976.

This system can be further sophisticated by adding a small computer at the control console to assist in controlling the blast simulators. Similarly, a telemetry link can be added to a firing battery; where, using electromechanical devices firing data on the artillery pieces can be picked off

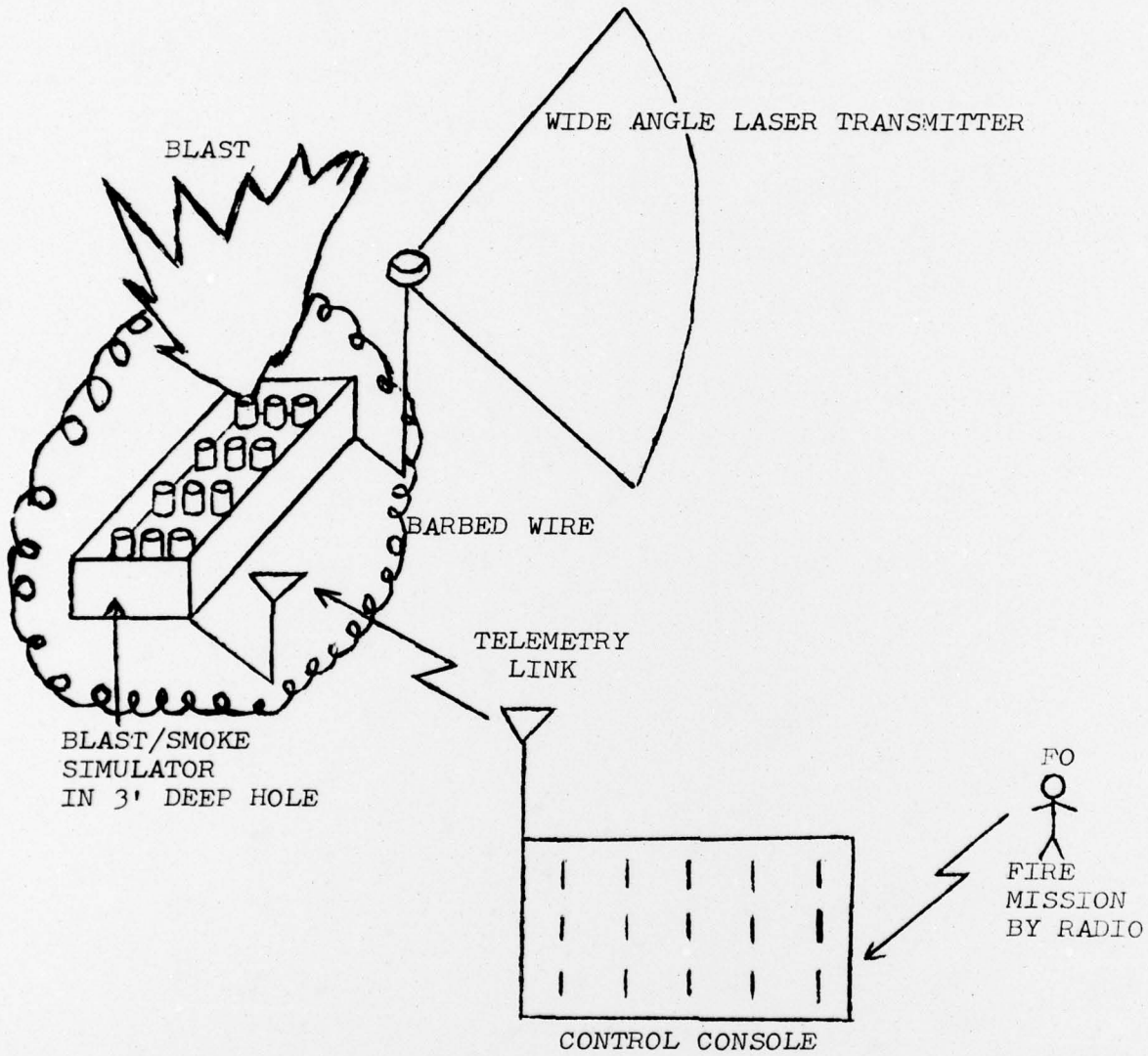

Figure 17. Indirect Fire Simulation System

and transmitted to the computer. This data would be converted to UTM coordinates by the computer, and the blast simulator(s) nearest the designated coordinates would be detonated.

LASER GUIDED PROJECTILES

By the early 1980s laser guided missiles/projectiles will be in the Army inventory. Techniques must be developed to simulate the effects of these systems in training.

The HELLFIRE laser guided missile system which is to be the main antitank weapons system on the advanced attack helicopter is a typical laser designation/homing system. In HELLFIRE targets are "illuminated" by high energy lasers either from the ground with the Ground Locator Laser Designator (GLLD) or from the air by the Airborne Locator Laser Designator (ALLD). Laser energy reflected from the target vehicle is sensed by "seekers" on the HELLFIRE missile head which "lock-on" to the reflected laser energy. The missile then follows the reflected laser energy to the target.

The simplest way to simulate the effects of this system is to use the actual GLLD and ALLD, but for casualty assessment add special laser detectors (laser alarms) on the target vehicles which detect only GLLD and ALLD laser energy (MILES laser detectors are looking for MILES laser transmitter codes and will not sense GLLD or ALLD energy). The laser alarms would be tied in to the MILES control electronics. Once the GLLD or the ALLD tracked the target vehicle for the prescribed time, casualty assessment would be performed by the MILES electronics logic, and "kill" indications would be accomplished using the MILES kill indicator.

A technique similar to this was used in the CDEC HELLFIRE experiment in 1974.

GLLDs and ALLDs are not eye-safe and require the use of special laser protective goggles by all players. However, this should not pose a major problem; because, laser protective goggles should become an item of standard issue for use in the "laser battlefield."

BIBLIOGRAPHY

BIBLIOGRAPHY

BOOKS

- Campbell, William G., and Stephen Vaughan Ballou. Form and Style: Theses, Reports, Term Papers/4th Edition. Boston: Houghton Mifflin Company, 1974.
- Issac, Stephen, and William B. Michael. Handbook in Research and Evaluation. San Diego: Edits Publishers, 1971.
- Lytel, Allan. ABC's of LASERS and MASERS. New York: Howard W. Sams and Co., Inc., January 1963.
- Marshall, Albert H. Laser Man versus Man Weapons Fire Simulation. Orlando, Florida: Naval Training Equipment Center, November 1973.
- Marshall, S.L.A. Men Against Fire. New York: William Morrow & Company, 1966.

GOVERNMENT DOCUMENTS

- Hunter, Richard U. Final Instrumentation Report FCO21 HELLFIRE. Fort Ord, CA.: BDM Scientific Support Laboratories, May 1975.
- Lam, Larry J. Final Instrumentation Report for Experiment 23.1. Fort Ord, CA.: BDM Scientific Support Laboratories, March 1973.
- Pope, Brent D. "An Analysis of the Process of Management by Objectives Adapted to an Army Battalion." Master's Thesis, U.S. Army Command and General Staff College, Fort Leavenworth, Kansas, 1975.
- Roper, George. Final Instrumentation Report for Experiment 43.0. Fort Ord, CA.: BDM Scientific Support Laboratories, 1972.
- ARTEP 7-45. Army Training and Evaluation Program for Mechanized Infantry Battalion and Combined Arms Task Force w/C1. Headquarters, Department of the Army, 9 September 1975.

- FM 21-6. How to Prepare and Conduct Military Training. Headquarters, Department of the Army, November 1975.
- FM 23-3. Tactics, Techniques and Concepts of Antiarmor Warfare. Headquarters, Department of the Army, August 1972.
- FM 23-82. 106-MM Recoilless Rifle M40A1 w/C1-C3. Headquarters, Department of the Army, May 1964.
- TRADOC Bulletin #1. Range and Lethality of U.S. and Soviet Anti-Armor Weapons. Fort Monroe, VA.: U.S. Army Training and Doctrine Command, 30 September 1975.
- TRADOC Bulletin #2. Soviet ATGMS: Capabilities and Countermeasures. Fort Monroe, VA.: U.S. Army Training and Doctrine Command, April 1975.
- TRADOC Bulletin #8. Modern Weapons on the Modern Battlefield. Fort Monroe, VA.: U.S. Army Training and Doctrine Command, 31 December 1975.
- TC 7-24. Antiarmor Tactics and Techniques for Mechanized Infantry. Headquarters, Department of the Army, 30 September 1975.
- TC 17-12-5. Tank Gunnery Training w/C1. Headquarters, Department of the Army, September 1975.
- TC 21-5-2. Training Management Digest No. 2. Headquarters, Department of the Army, June 1974.
- TC 23-23. TOW Heavy Antitank Weapon System w/C1-C2. Headquarters, Department of the Army, July 1970.
- TOE 7-47H. Mechanized Infantry Company w/C13. Headquarters, Department of the Army, 1 September 1976.
- Technical Paper TP-76. Analysis of Antiarmor Effectiveness with BLDM. Fort Leavenworth, KS.: U.S. Army Combined Arms Combat Development Activity, April 1976.
- Technical Report TR3-72. TETAM Model Verification Plan. Fort Leavenworth, KS.: U.S. Army Combined Arms Combat Development Activity, 29 November 1973.
- Technical Report TR3-74. Simultaneous Line-of-Sight Terrain Effects on Remoted Weapon Systems. Fort Leavenworth, KS.: U.S. Army Combined Arms Combat Development Activity, 10 June 1974.

Antiarmor Operations of Combined Arms (Volume I & Volume II).
Fort Leavenworth, KS.: U.S. Army Command and General
Staff College, 6 June 1975.

Antiarmor Systems Program Review (ASPR)-1976 (Senior Attendee
Fact Book). Fort Leavenworth, KS.: U.S. Army Combined
Arms Center, 27-28 April 1976.

TETAM, Final Report Vol. I. (Executive Summary Phases I & II).
Fort Ord, CA.: U.S. Army Combat Developments Experimenta-
tion Command, September, 1973.

PERIODICALS AND ARTICLES

"Special Tactics Section," Infantry, September-October 1976,
pp. 15-51.

UNPUBLISHED MATERIAL

Understanding the ARTEP, Fort Leavenworth, KS.: U.S. Army
Command and General Staff College, 1976.

Design Review Conference. Multiple Integrated Laser Engage-
ment System (MILES). Electro-Optical Systems, XEROX
Corporation, Pasadena, CA.: 23 September 1976.

Tank vs. TOW Test, USA 3d Infantry Division, Federal Republic
of Germany, June 1972.

Specification for Direct Fire Simulator System (DFS). USA
Combat Developments Experimentation Command, Fort Ord,
CA.: August 1973.

Summary of Soviet Tactics, Weapons, and Equipment, handout,
Command and General Staff College, Fort Leavenworth,
KS., August 1976.

OTHER SOURCES

Laser Engagement System. Electro-Optical Systems, Pasadena,
CA.: XEROX Corporation.

Statement by Major Larry Word on Multiple Integrated Laser
Engagement System (MILES) Characteristics, personal
interview, TRADOC Training Support Center, Fort Eustis,
VA., 16 November 1976.

Study Advisory Group (SAG) Meeting: Cost and Operational Effectiveness Analysis (OEA) of Crew Protection for TOW and Gunner Protection for DRAGON, Headquarters, U.S. Army Training and Doctrine Command, Fort Monroe, VA., 30 April 1975.