

AD-A044 599

ILLINOIS UNIV AT URBANA-CHAMPAIGN DEPT OF COMPUTER SCIENCE F/G 9/2  
OPTOBUNDLE - A UNIQUE FIBER OPTIC MULTIPLIER, (U)  
JUN 77 D A PITT, W J POPPELBAUM, C J XYDES N00014-75-C-0982

UNCLASSIFIED

UIUCDCS-R-77-882

NL

1 OF 1  
ADA  
044599

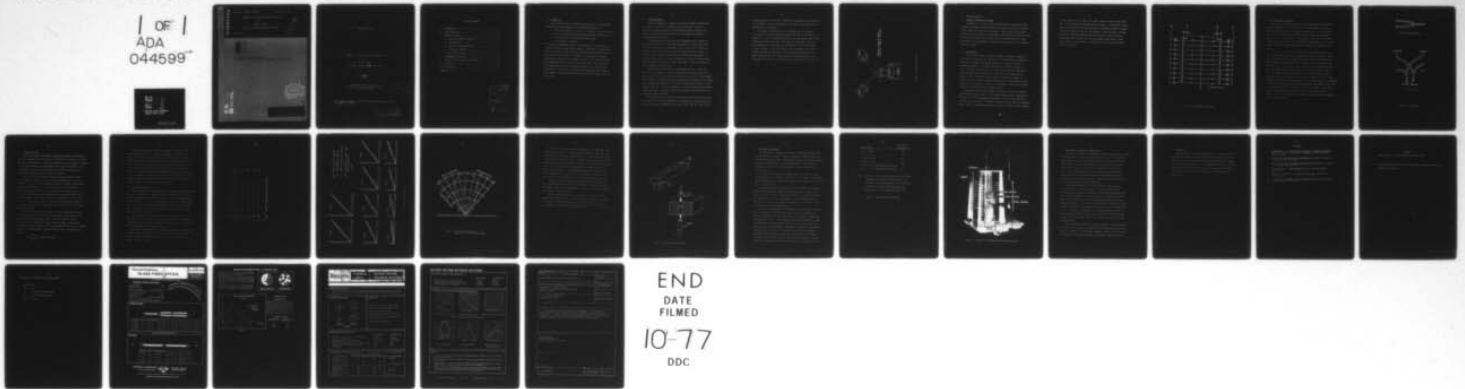

AD A 044 599

Report No. UIUCDCS-R-77-882

UIIU-ENG 77 1741

OPTOBUNDLE - A Unique Fiber Optic Multiplier

by

Daniel A. Pitt

Wolfgang J. Poppelbaum and Christ J. Xydes

June 1977

Handwritten circled numbers: 12 and 14



DEPARTMENT OF COMPUTER SCIENCE  
UNIVERSITY OF ILLINOIS AT URBANA-CHAMPAIGN · URBANA, ILLINOIS

AD No. \_\_\_\_\_  
DDC FILE COPY

DDC  
RECEIVED  
SEP 26 1977  
A

DISTRIBUTION STATEMENT A  
Approved for public release;  
Distribution Unlimited

19  
UIUCDCS-R-77-882

6  
OPTOBUNDLE - A Unique Fiber Optic Multiplier,

by

10  
Daniel A. Pitt,  
Wolfgang J. Poppelbaum and Christ J. Xydes

11  
June 1977

12  
32p.

Department of Computer Science  
University of Illinois at Urbana-Champaign  
Urbana, Illinois 61801

DDC  
RECEIVED  
SEP 26 1977  
A

This work was supported by the Office of Naval Research under contract number N00014-75-C-0982.

15

176 011

DISTRIBUTION STATEMENT A  
Approved for public release;  
Distribution Unlimited

108

TABLE OF CONTENTS

1. INTRODUCTION.....1

2. BUNDLE PROCESSING.....2

3. OPTOBUNDLE MACHINE.....5

    3.1 DESIGN OF OPTOBUNDLE PROTOTYPE.....5

    3.2 INPUT ENCODER.....5

    3.3 OPTICAL FIBER ARRANGEMENT.....8

    3.4 COUPLING OF FIBERS.....10

    3.5 LED-FIBER INTERFACE.....11

4. PERFORMANCE OBSERVATIONS.....17

5. EXPLANATION OF EMI-INDUCED LIGHT OUTPUT.....20

6. CONCLUSION.....21

LIST OF REFERNCES.....22

APPENDIX.....23

ACCESSION FOR	
WTE	White Section <input checked="" type="checkbox"/>
DOC	Swift Section <input type="checkbox"/>
UNANNOUNCED	<input type="checkbox"/>
JUSTIFICATION	
BY	
DISTRIBUTION AVAILABILITY CODES	
Dist.	AVAIL. and/or SPECIAL
A	

1. Introduction

This paper describes the design and construction of a unique hybrid single digit decimal multiplier with the following properties:

1. Almost total immunity to severe electromagnetic interference (EMI)
2. Failsoft behaviour with degradation proportional to destruction
3. No system clock or resultant speed restrictions
4. Trivial amount of hardware

To obtain these properties, numbers are represented in a unary system as vectors with ten unordered binary components. Arithmetic processing with this form of number representation is called bundle processing and will be detailed in the next section. In addition to using bundle processing, Optobundle also employs optical fibers not only to carry the information of the components but also to perform the multiplication. While even under ideal conditions this form of multiplication gives only a single digit approximation to the product, this product is stable amidst very adverse electromagnetic conditions which would cause conventional systems to err a great deal.

## 2. Bundle Processing

Bundle processing is a probabilistic system of number representation utilizing a finite number of binary data lines grouped in a bundle to carry the information signals.<sup>1</sup> By detecting the spatial average of the number of lines which are active out of a given bundle, the numerical information can be extracted.

Being probabilistic implies that all information must be mapped onto the closed interval  $[0,1]$ . Given any such number  $X$ , it can be represented by the ratio  $n/N$  where  $n$  is the number of active lines out of a bundle of  $N$  lines. This ratio  $n/N$  does not, unlike conventional binary, depend on which  $n$  lines are active. Each line in a bundle has the same weight:  $1/N$ . The maximum error will be  $\pm 1/2N$ . Obviously, the accuracy of representation increases with  $N$ , the number of lines in the bundle. As in any system, one must compromise accuracy for cost.

Bundle processing exhibits some interesting properties. Since any given line has a weight of  $1/N$ , its failure would not severely degrade the entire system.<sup>3</sup> The result would be incorrect by at most  $1/N$  for each damaged line. Another interesting property is the inherent parallelism which is present. As is becoming more apparent, if one wants to increase system speed, one must introduce some form of parallel operation. In bundle processing, all arithmetic operations are done in parallel, exhibiting virtually no delay between input changes and output responses.

With this in mind, one may note the simplicity of bundle multiplication.<sup>2</sup> If one input to a two-input AND gate has a probability  $X_1$  of being active and the other input has a probability  $X_2$  of being active, then the output has the

probability  $X_1 X_2$  of being active, provided of course that the two inputs are not correlated. Thus the probability of the output is the product of the probabilities of the inputs.

If two equal sized bundles are to be multiplied, one chooses at random one line from each bundle and connects the pair to the inputs of an AND gate.<sup>6</sup> If this is repeatedly done until each line is used exactly once,  $N$  AND gates will have been used. The outputs of these gates from a new bundle whose value is the product of the values of the two input bundles as shown in Figure 1. The total delay to form the product is the delay through the  $N$  parallel AND gates! There are many more facets of such a number representation which obviously have not been presented here. For an in-depth discussion of bundle processing one should consult (2) and (3).

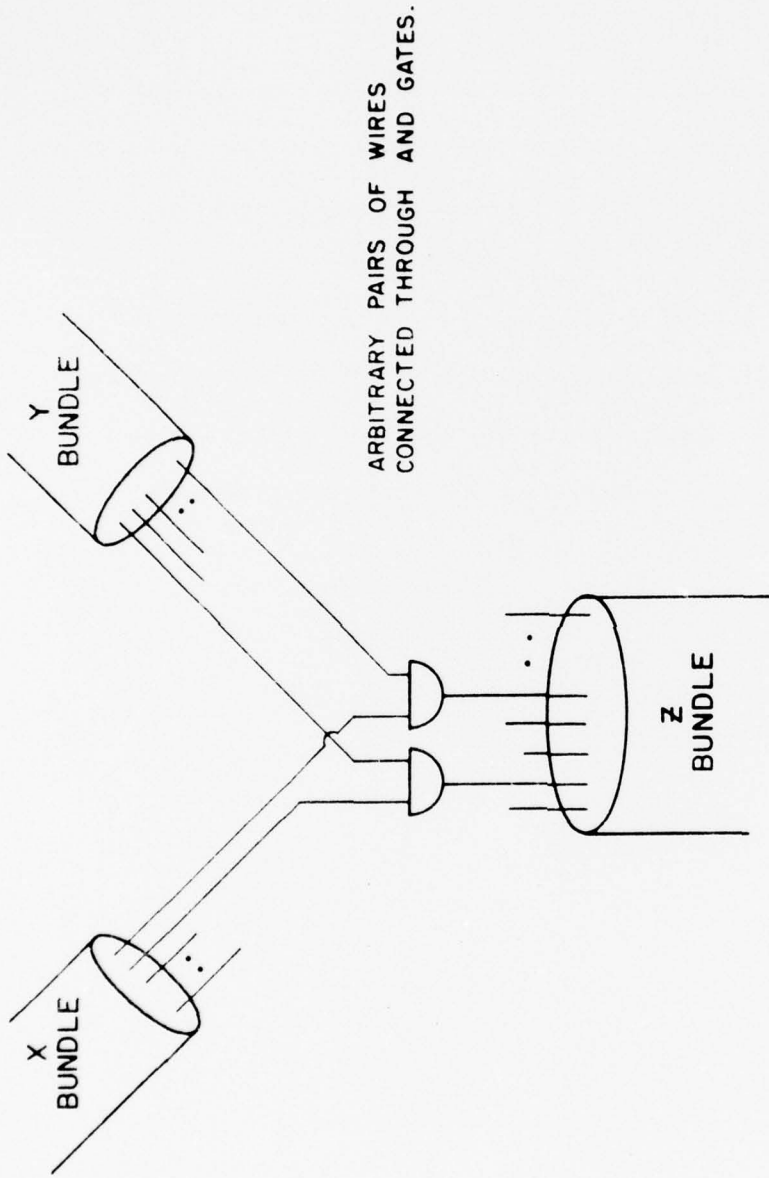

Figure 1. Bundle Multiplication

### 3. Optobundle Machine

#### 3.1 Design of Optobundle Prototype

Considered as a black box, this prototype version of Optobundle takes as inputs two analog voltages and gives as an output a bundle of ten optical fibers, some of which may be lit, some dark. Within the box are two major sections--the input encoder, and the fibers. The decision to use fibers rather than wires was prompted by the desire to have a machine survive in a noisy environment and be lightweight. The input encoder, then, had to be designed with this in mind.

#### 3.2 Input Encoder

For each input signal, the encoder converts a voltage to a number of lit fibers in a bundle of ten. The choice of this bundle size is simply for convenience in mapping onto decimal quantities. The input voltage is essentially applied to a string of ten LEDs each of which is coupled to a fiber. With the input voltage at its lowest point, all of the LEDs are ON; as the voltage increases they go OFF. The choice of counting either the number of lit or the number of unlit fibers to represent the number is arbitrary, but the nature of bundle processing and the fibers yields certain advantages if one chooses a darkness → "one" mapping. This will be explained further in the subsection dealing with the fibers.

Application of each input voltage is done with a 50 ohm potentiometer connected between ground and 10V. This yields a swing from 5V, representing the number 0, to 10V, representing the number 1 (or 10 if scale factors are considered in the product). Progressive turning off of the LEDs is accomplished using a ladder of 1N995 germanium diodes. In order to obtain a linear response

in the turning off of the LEDs as the input voltage is raised, these diodes had to be hand picked for matching turn-on voltages. It was decided, however, that this method was easier than generating ten different reference voltages. Current is limited by identical 1.5K resistors to keep the LEDs at the same brightness. Monsanto MV10B LEDs were used because of their availability and because their relatively narrow viewing angle allowed them to couple easily with the optical fibers. A circuit diagram of the encoding scheme is given in Figure 2.

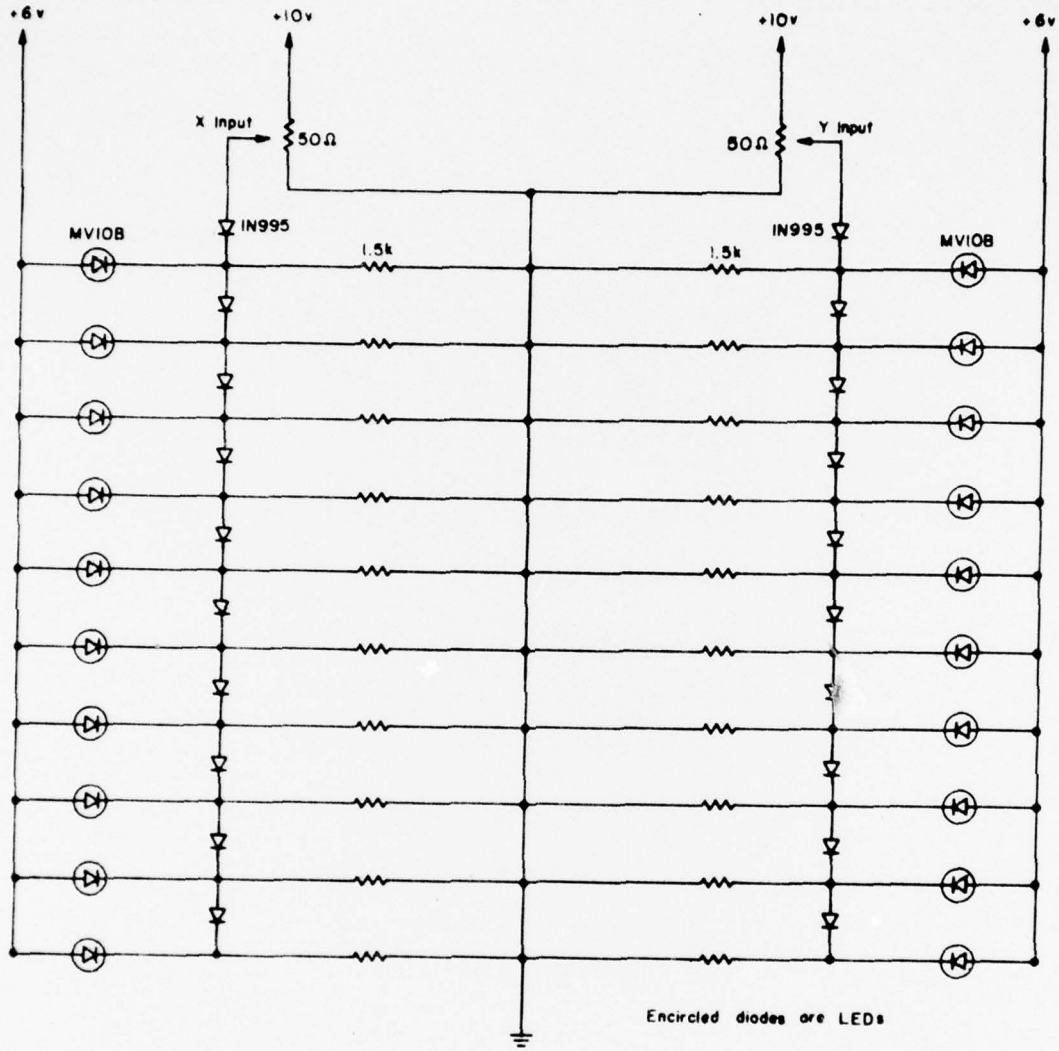

Figure 2. OPTOBUNDLE Input Encoder

### 3.3 Optical Fiber Arrangement

Recall that in bundle processing the multiplication of two quantities is done by ANDing ordered pairs of lines, one from each bundle, in some kind of random fashion. If the lines are light paths, as is the case here, then what is the easiest way to AND two paths? We found that if negative logic is used, i.e., darkness on a fiber means 1, light mean 0, then simply connecting two light paths into one produces the AND function. This way only darkness on one fiber and darkness on the other will give darkness at the output.

In order to connect two light paths into one, Optobundle uses 610 mm model EEK bifurcated glass fiber light guides 1/16 inch in diameter. These fibers, available from Dolan-Jenner Industries, allow half of the individual fiber strands in a given light guide to randomly go to one bifurcated end, the other half of the other end. One bifurcated end then couples to an LED from the X ladder, the other to one from the Y ladder as shown in Figure 3.

What appears at the non-bifurcated end of each fiber then is either darkness, half of the strands lit, or all of the strands lit. Since in this prototype we merely observed the ends visually, we found it easier to distinguish between complete darkness and some light than between some light and more light. For automated response it is obviously a matter of thresholds, and given the proper thresholds, positive as well as negative logic could be used. In either case, however, the operation of ANDing is done with no other components than the fibers themselves.



a. Bifurcated Fiber Bundle

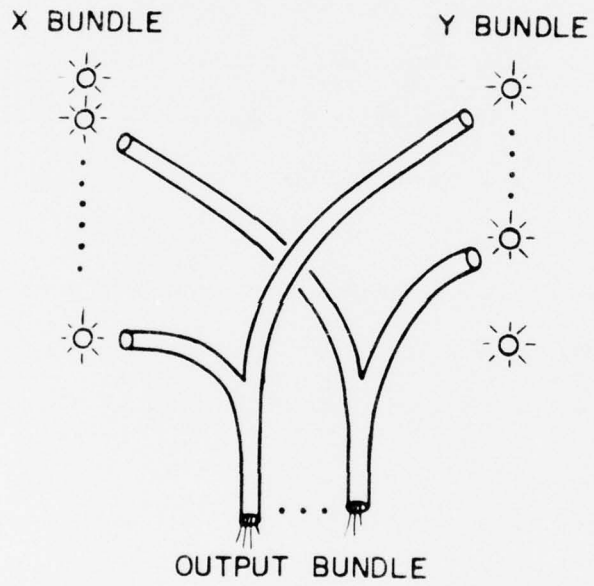

b. Fiber connections

Figure 3. Fiber Logic

### 3.4 Coupling of Fibers

Recall from Figure 1 that bundle multiplication assumes two conditions. The first condition is that the choice of which wires are connected to a given AND gate is a random choice. The second condition is that each wire in a bundle has the same probability of being ON whatever the value of the bundle. That is tantamount to saying that as the value of the bundle increases, one cannot predict which wire will be the next to turn ON.

Given the fact that in this prototype the fibers turn ON in a step-wise deterministic fashion, and not in a random fashion at all, it became necessary to choose a coupling scheme which was not random but rather which gave the best performance. This entailed simulating the multiplication method and determining criteria for choosing a "good" coupling scheme. Let us consider single digit integer multiplication, dividing the result by 10, and then rounding to the nearest integer. For example,  $6 \times 6 = 4$ ,  $2 \times 3 = 1$ ,  $9 \times 7 = 6$ . Using natural rounding, in which any fraction greater than  $1/2$  is rounded to the next higher integer, let us consider this to be the ideal single digit scheme.

The figure of merit we have chosen is the total squared error, which is the sum of the squares of each deviation between a given scheme and the ideal scheme at the 100 product points. Note that X times Y may not necessarily equal Y times X for a given coupling scheme. Let  $C_i(X,Y)$  be the product of X and Y using the  $i^{\text{th}}$  coupling scheme and let  $I(X, Y) = [X \cdot Y / 10]_r$  be the ideal product, where  $[ ]_r$  denotes rounded value. Then the error is given by

$$E_i = \sum_{X=1}^{10} \sum_{Y=1}^{10} (C_i(X,Y) - I(X,Y))^2.$$

Several coupling schemes were investigated, some being chosen by pulling numbers out of a hat, others by intuition. The schemes and their error values are given in Table 1. We decided to use the scheme with the lowest error value from the initial set of five without attempting to find schemes with lower error values. While we do not know of, nor did we search analytically for, any lower bound on  $E_i$ , the clustering around the value of 30 should perhaps indicate we have at least come close to a local minimum. In any case, a series of graphs depicting the resulting products along with the ideal products and the true analog products is given in Figure 4 for the chosen coupling scheme  $C_1$ .

### 3.5 LED - Fiber Interface

When considering the performance limits of an actual fiber transmission system, it is necessary to consider the input coupling efficiency. One of the many factors which affects such efficiency is the relative positioning of the fiber to the light source. As shown in Figure 5, the relative light output is at a maximum when the light source is directly in line with the axis of the fiber. This output diminishes to zero as one approaches the limit of the acceptance angle.

When observing the emission characteristics of the LEDs, one immediately notices a similarity. As can be seen in the specifications for the MV10Bs, the light output is greatest at the on-axis point of the LED, and diminishes with distance away from the axis.

Taking both distributions into account, it is paramount to have proper alignment between LEDs and fibers. To have the light source displaced from the axis by a small amount could prove fatal for a transmission system of nontrivial length.

		X										F <sub>i</sub>	
		1	2	3	4	5	6	7	8	9	10		
Y	C <sub>1</sub>	5	3	10	4	8	6	7	7	1	2	9	26
	C <sub>2</sub>	1	10	6	4	9	3	7	7	8	5	2	29
	C <sub>3</sub>	4	7	3	2	9	5	6	6	10	8	1	37
	C <sub>4</sub>	2	4	6	8	10	1	3	5	5	7	9	33
	C <sub>5</sub>	10	9	8	7	6	5	4	3	2	1		111

Table 1 Coupling Schemes and Their Error Values

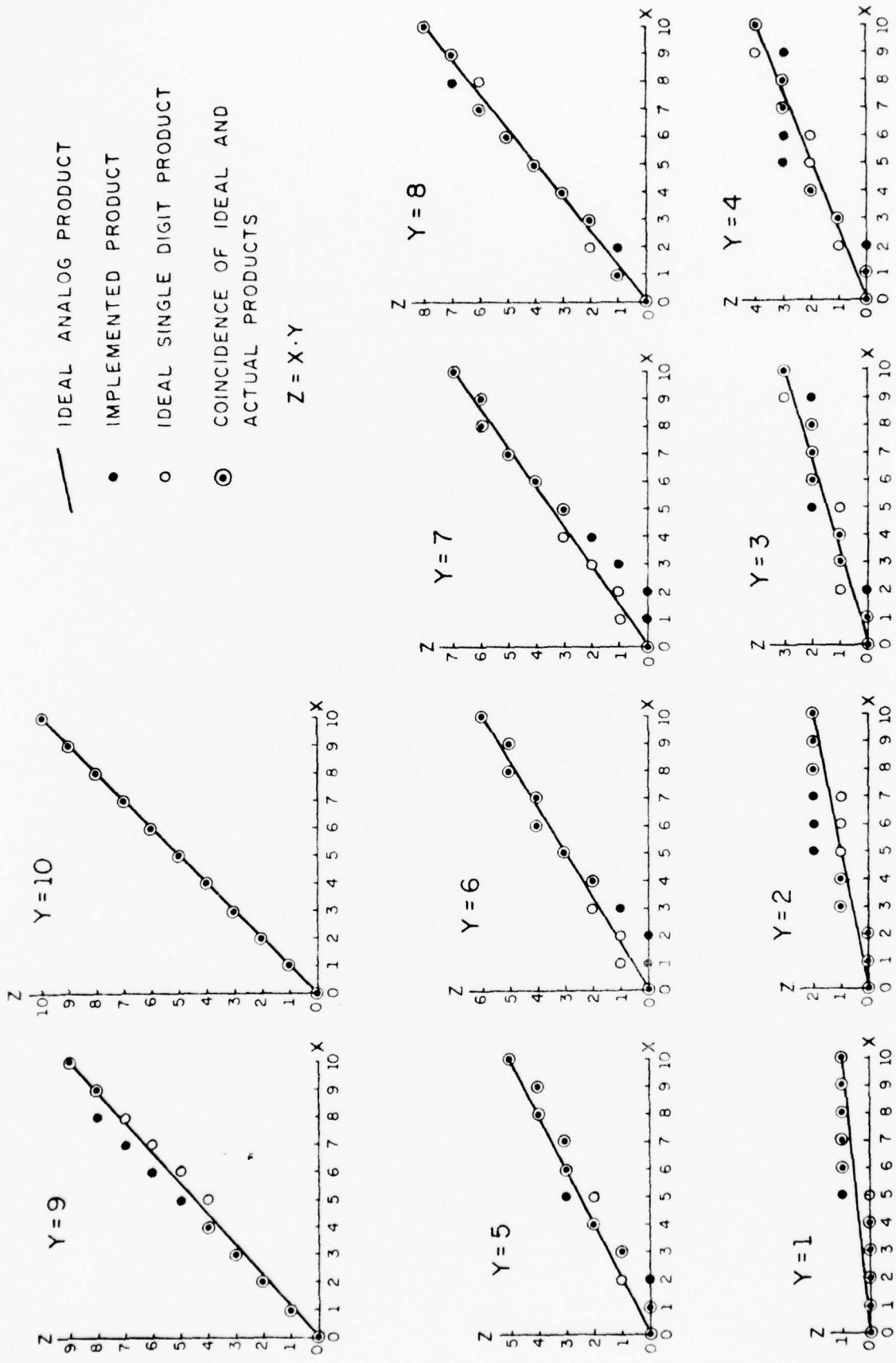

Figure 4 Product Accuracy

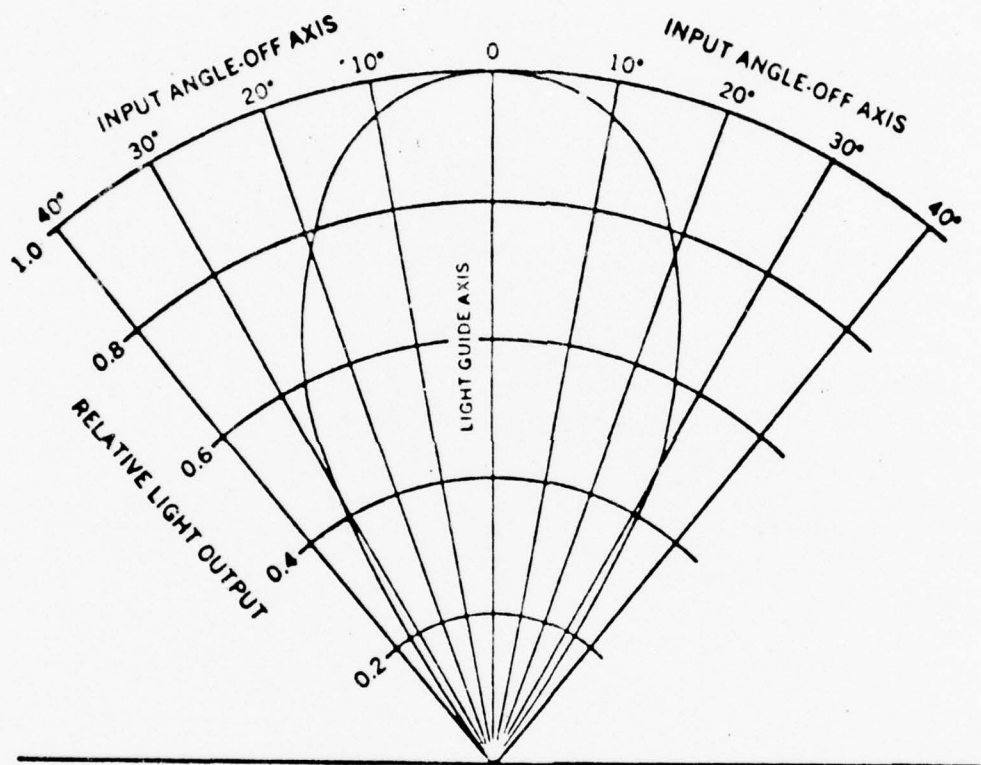

Figure 5 Relative Light Output vs.  
Input Direction of Collimated Light

The LED - fiber interface used in Optobundle was designed with axial characteristics in mind. A channel having the diameter of the fiber tip was drilled into one side of a plexiglass block. This provided the support and stability required by the fiber. Directly in line with this, and from the opposite side, another channel was drilled. This was the same diameter as that of the LED and provided the support and alignment required to effect a proper interface. The channel end closer to the fiber was then tapered toward the axis to guide the off-axis light from the LED to the fiber side of the interconnection. Figure 6 illustrates this connection.

As with any optical connection, crosstalk must be minimized. This was accomplished by using silver reflective paint on the inside of each LED channel. This effectively isolated each light source as well as aided in guiding the light to the fiber.

Thus the designed connector solved three major problems commonly present when dealing with optical links. No gluing, polishing, or grinding was required. Crosstalk was reduced to an acceptable level. Finally, the alignment of fiber to light source, which is so crucial, was resolved.

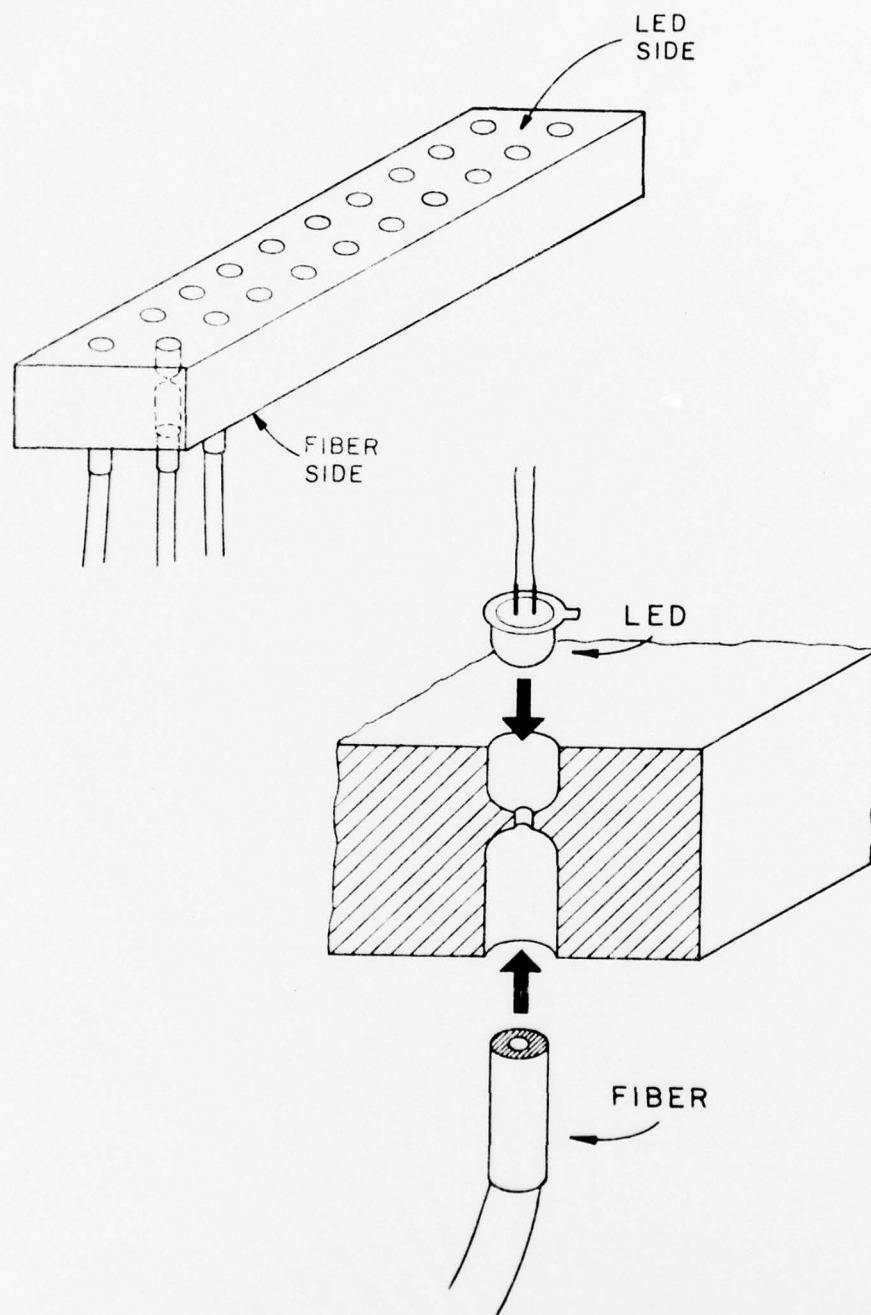

Figure 6 LED-Fiber Connection Block

#### 4. Performance Observations

The performance of Optobundle proved to be consistent with the design. Upon encoding the two inputs, a product consisting of darkened fibers was observed from the fiber bundle. As previously mentioned, automated decoding of the output would involve a thresholding mechanism. This motivated a quantitative analysis of the optical output to prove the feasibility of such an approach.

By placing a light meter at the bundle output, the light flux under various conditions was obtained. The flux of all ten fibers lit was measured, and then divided by ten to obtain the average flux per fiber. The accumulated data are shown in Table 2.

In examining the data, several points need to be made. The difference between the value of the X ladder and the value for the Y ladder is the result of several factors. The physical properties of the individual LEDs and the fibers can vary to a small degree. Also the LED-fiber interface may vary in efficiency from connection to connection. This is due to the fact that this is a hand made prototype.

In order to test optobundle for immunity to EMI, we mounted it in the worst environment locally available, namely in the region between the primary and secondary of a Tesla transformer. A photograph of the arrangement can be seen in Figure 7. The available transformer produce 200kV AC. When the transformer is turned on, its effect is to add  $.05 \text{ nW/cm}^2$  light flux output from each 10-fiber bundle. Compared to the normally bright bundles, this represents an increase of 0.6% which for all practical purposes is negligible, since even when a given fiber has only half of its strands lit there is still a SNR of 19dB, and only two-level decoding is required. However, an explanation of this increased output is in order and follows.

<u>Test Condition</u>	<u>Flux x10<sup>-9</sup> watts/sq. cm.</u>
(X = Y = 1.0)	0.0
X = 0.0 Y = 1.0	7.4
X = 0.0 Y = 0.0	8.2
X = 0.0 Y = 0.0	15.3
X = 0.0 Y = 0.0 (With Tesla Coil Active)	.1
X = 1.0 Y = 1.0 (With Tesla Coil Active.)	15.4

Note: An input at the 1.0 position will have all the LEDs connected to that side of the input encoder off.  
An input at the 0.0 position will have all the LEDs connected to that side of the input encoder on.  
Thus when X = Y = 0.0, twenty LEDs will be on.

Table 2 Average Light Flux Per Fiber

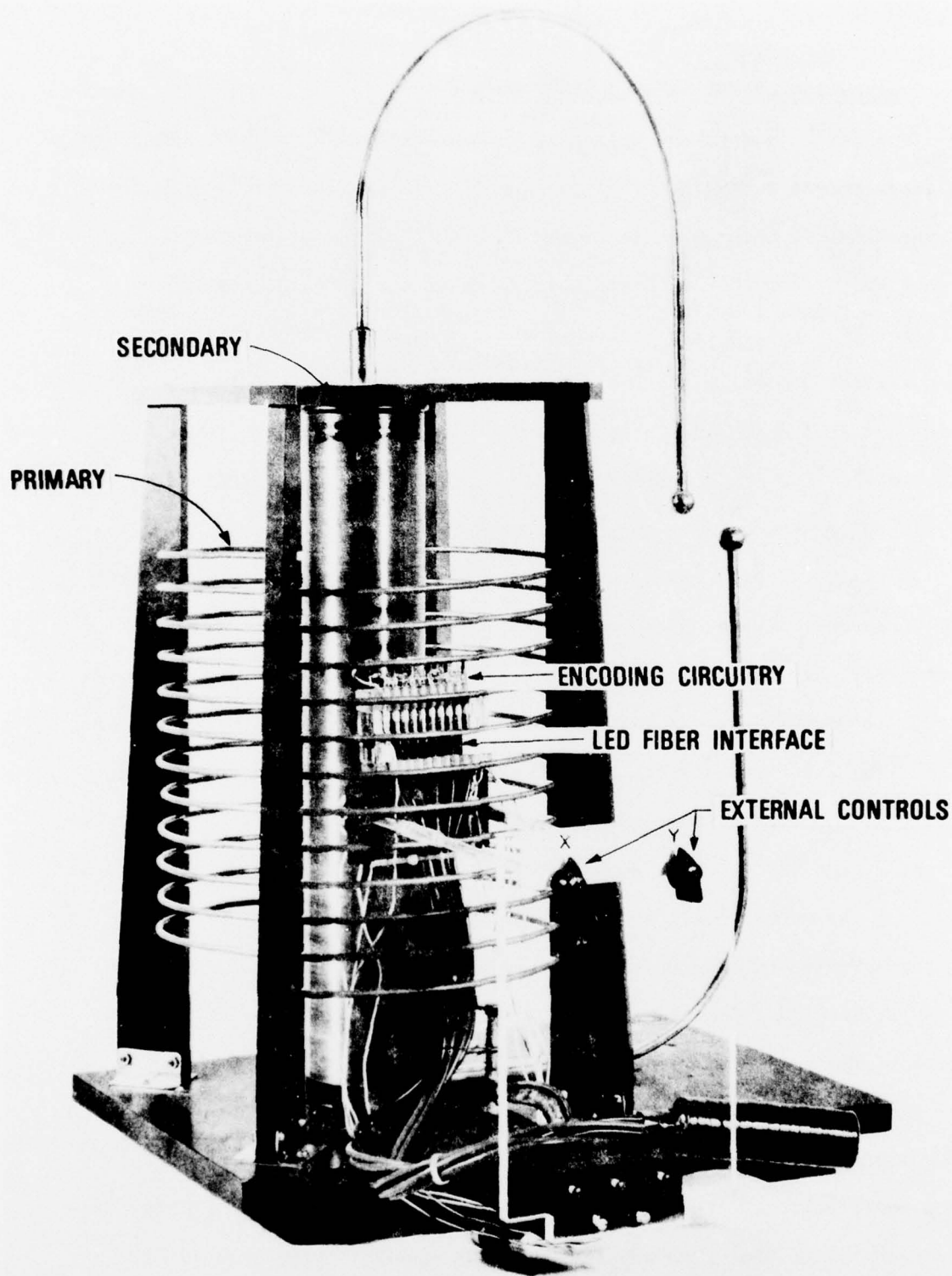

Figure 7. Mounting of OPTOBUNDLE Inside Tesla Transformer

5. Explanation of EMI-induced light output

In order to understand this performance aberration consider the potential variation across a reverse biased p-n junction in an LED. It is such that the potential of the n side is higher than that of the p side, and hence current would flow only if there were holes in the n region that could drift to the p region or electrons in the p region that could drift to the n region. Normally there are very few minority carriers in each region and in fact the depletion region on either side of the junction contains very few free carriers at all. Those that are present are hole-electron pairs which are generated thermally.

In the MV10B data sheet it is stated that the reverse current rarely exceeds .3  $\mu$ A at 3V reverse bias. In the field of the Tesla transformer, however, energy is imparted to the Gallium Arsenide Phosphide crystal as electromagnetic radiation and serves to generate hole-electron pairs. The minority carriers in each region are accelerated toward and across the junction by the junction potential and thus constitute a reverse current of somewhat greater magnitude than normal. It is the recombination of all of these hole-electron pairs that causes the added brightness, as the energy released when an electron falls back from the conduction band to the valence band appears in the form of light in GaAsP and other light emitting crystals.

Under forward bias conditions, the newly generated carriers constitute a forward current as majority carrier and their recombination again causes light to be emitted. Under both bias conditions, though, none of the turn-on thresholds is disturbed and therefore the products remain as before.

6. Conclusion

The feasibility of an optical implementation of a bundle multiplier has been shown by the actual construction and testing of such a device at the Information Engineering Laboratory of the Department of Computer Science, University of Illinois. It is expected that the price of optical fibers will decrease over the next few years as their use proliferates and such a machine may be entirely practical for hazardous and noisy applications.

References

1. Poppelbaum, W. J., A Practicability Program in Stochastic Processing, Office of Naval Research Proposal, Department of Computer Science Urbana, IL, 1973.
2. Ring, David, BUM - Bundle Processing Machine, Department of Computer Science Report No. 353, 1969.
3. Tse, Bernard, BURP - A Bundle Repeater Restorer, Department of Computer Science, Report No. 689, 1974.
4. Poppelbaum, W. J., Computer Hardware Theory, MacMillan Company, New York, 1972.
5. Millman, J. and Halkias, C. Integrated Electronics, McGraw-Hill, New York, 1972.
6. Coombes, Daniel, SABUMA - Safe Bundle Machine, Department of Computer Science, Report No. 412, 1970.

Appendix

Performance data on switching diodes, LEDs, and fibers.

The following data sheets are used by permission of Dolan-Jenner Industries and Monsanto Corporation.

Performance of the 1N995 Fast Switching Diode

Material Ge

PIV 15

$I_f$  10 ma at 1.0V forward bias

$I_r$  10  $\mu$ a 6.0V reverse bias

$t_{RR}$  6 ns max

# GLASS FIBER OPTICS

BK, EK, EEK  
FiberOptics

ALL DIMENSIONS IN METRIC SYSTEM

## GENERAL SPECIFICATIONS

Acceptance cone	67°
Numerical aperture	0.55
Spectral transmission	0.4- 2.1 microns
(Refer to Figure 1 below for complete specifications)	
Individual fiber diameter	076
Temperature rating	100 C
Standard lengths	304.8, 609.6, 914.4MM
(Available from stock)	



Other lengths up to 6100 MM available on special order.

## TYPES EK, EEK

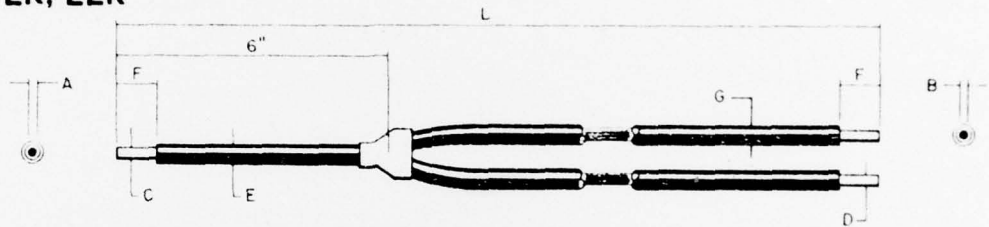

DJI TYPE NO.	"L" (STOCK LENGTHS)	"A"	"B"	"C"	"D"	"E"	"F"	"G"
EEK07 — EK07 —	305, 610, 914	.686	.495	1.080 ± .013	.813 ± .013	2.210 Max.	12.7	1.956 Max.
EEK15 — EK15 —	305, 610, 914	1.600	1.194	2.108 ± .025	1.651 ± .013	3.226 Max.	12.7	2.794 Max.
EK30 —	305, 610, 914	2.997	2.159	3.759 ± .025	2.769 ± .025	5.182 Max.	12.7	3.810 Max.

ALL DIMENSIONS ARE MILLIMETERS

## TYPE BK

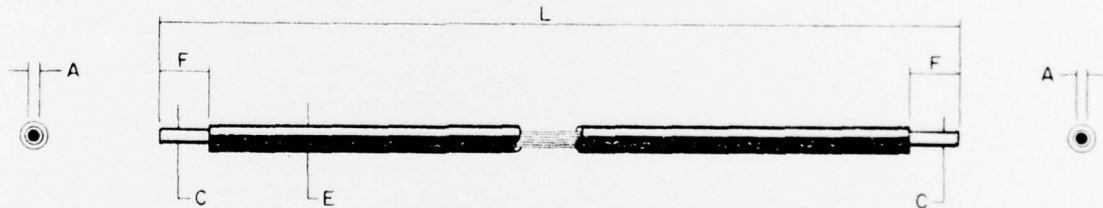

DJI TYPE NO.	"L" (STOCK LENGTHS)	"A"	"C"	"E"	"F"
BK15 —	305, 610, 914	1.600	2.108 ± .025	3.226 Max.	12.7
BK30 —	305, 610, 914	2.997	3.759 ± .025	5.182 Max.	12.7
BK45 —	305, 610, 914	4.394	5.156 ± .025	6.858 Max.	12.7

Dolan-Jenner  
Industries, Inc.



Electronic Controls  
And Fiber Optics

200 Ingalls Court, Melrose, Massachusetts Telephone 617-662-8200 Cable: DOJEN

Manufacturers Of Glass and Plastic Fiber Optics

## BIFURCATED FIBER OPTICS — TYPES EK, EEK

Types EK and EEK are identical in exterior appearance and dimension — they differ only in the orientation of fibers in the common (major diameter) bundle.

With the Type EK, the fibers are intermixed (randomized) from each leg to produce a uniform dispersion within the entire cross sectional bundle area of the common (major diameter) leg. Typical uses of randomized types include photoelectric sensing probes, color integration, and similar applications.

With Type EEK the common (major diameter) leg is simply divided into two branches of equal bundle diameter. Typical usage of Type EEK is a dual light pipe in conjunction with a single illuminator or as a simple "Beam splitter".

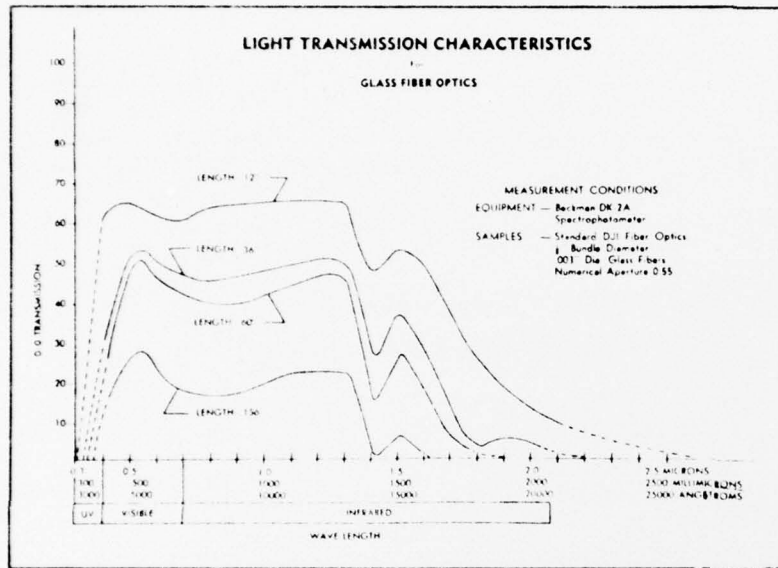
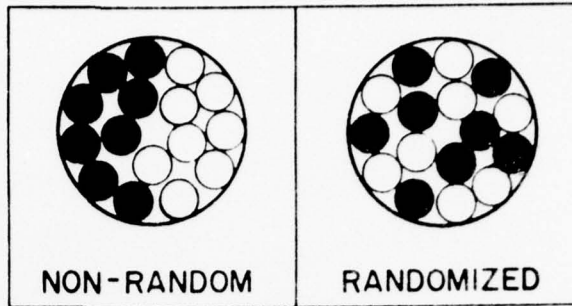

Figure 1

### CONSTRUCTION

#### TYPES BK, EK, EEK

Non coherent bundles consisting of .076 dia optical glass fibers with PVC sheathing, close tolerance stainless steel terminations. Types BK, EK and EEK are designed for minimal handling, since PVC sheathing does not contain internal flexible metal protective sheathing. Where usage will involve moderate to heavy handling, shock or vibration, DJI Micro-Optic industrial and heavy duty fiber optic scanners are recommended.

### BENDING RADIUS

Bundle Dia. - MM (".A" Dimension)	Minimum Bending Radius - MM
.686	4.763
1.600	6.350
2.997	12.700
4.394	19.050

# Monsanto

## VISIBLE LED's

## MV10A MV10B MV10A3 MV10B3

### PRODUCT DESCRIPTION

The MV10A and MV10B series of visible light emitting diodes are made of Diffused GaAsP. The A series is mounted on .110" coaxial headers with a protective epoxy lens. The B series is mounted in a TO18 header with a protective epoxy lens.

### PACKAGE DIMENSIONS

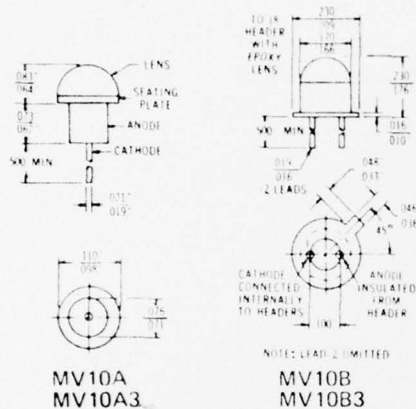

MV10A  
MV10A3

MV10B  
MV10B3

See note 3

### FEATURES

- High Efficiency--5mA max. to produce 50 ft-L.
- Ultra High Brightness--Typ. 1000 ft-L @50mA.
- Long Life--Solid State Reliability.
- Low Power Requirements--Typ. 10mW for 50 ft-L.
- Compatible with Integrated Circuits--DTL, RTL, TTL.
- Compact, Rugged, Lightweight.

### ABSOLUTE MAXIMUM RATINGS

	MV10A-MV10A3	MV10B-MV10B3
Maximum Power Dissipation @25°C Ambient Temperature Derate Linearly from 25°C	150mW 2.0mW/°C	175mW 2.33mW/°C
Maximum Storage & Operating Temperature	-55°C to +100°C	-55°C to +100°C
Maximum Lead Solder Time @260°C (see note 4)	7.0 s	7.0 s
Maximum Currents and Voltages Continuous Forward Current	70mA	70mA
Peak Forward Current (1µsec. pulse, 300 pps)	3.0A	3.0A
Reverse Voltage	3.0V	3.0V

### ELECTRO-OPTICAL CHARACTERISTICS

(25°C Free Air Temperature Unless Otherwise Specified)

CHARACTERISTICS	MV10A		MV10B	MV10A3		MV10B3	UNITS	TEST CONDITIONS
	MIN.	TYP.	MAX.	MIN.	TYP.	MAX.		
Brightness (see note 1)		500			1000		ft-L	I <sub>F</sub> =50mA
Current to produce 50 ft-L (see note 1)			10			5.0	mA	
Total external radiated power (see note 2)		50			100		µA	I <sub>F</sub> =50 mA, λ=6750 Å
Peak emission wave length	6300		7000	6300		7000	Å	
Spectral line half width		400			400		Å	
Forward voltage		1.65	2.0		1.65	2.0	V	I <sub>F</sub> =50 mA
Forward dynamic resistance		2.0			2.0		Ω	I <sub>F</sub> =50 mA
Capacitance		135			135		pF	V=0
Light turn on and turn off		1.0			1.0		ns	
Reverse current		0.3			0.3		µA	V <sub>R</sub> =3.0 V

# MV10A MV10B MV10A3 MV10B3

## TYPICAL THERMAL CHARACTERISTICS

Thermal Resistance Junction to Free Air ( $\Theta_{JA}$ )  
 Thermal Resistance Junction to Case ( $\Theta_{JC}$ )  
 Wavelength Temperature Coefficient (case temperature)  
 Forward Voltage Temperature Coefficient

### MV10A-MV10A3

350° C/W  
 170° C/W  
 3.0 Å/°C  
 -2.0 mV/°C

### MV10B-MV10B3

320° C/W  
 155° C/W  
 3.0 Å/°C  
 -2.0 mV/°C

## TYPICAL ELECTRO-OPTICAL CHARACTERISTICS CURVES

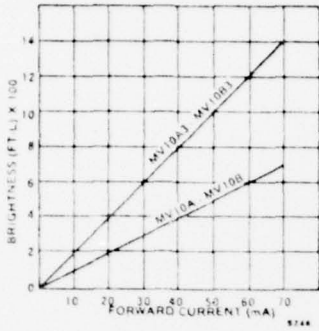

Figure 1 Brightness vs. Forward Current

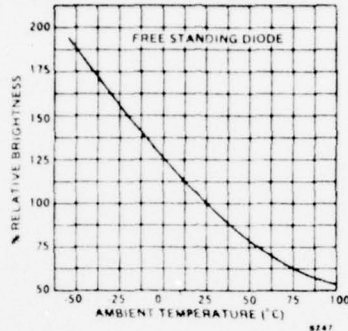

Figure 2 Brightness vs. Temperature

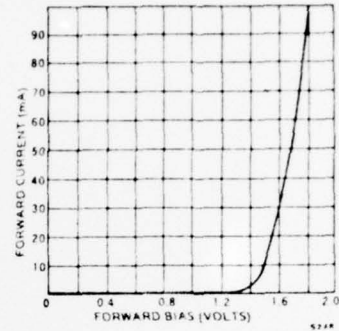

Figure 3 Forward Current vs. Forward Voltage

(25°C Free Air Temperature Unless Otherwise Specified)

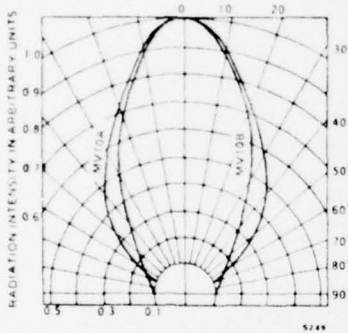

Figure 4 Spatial Distribution

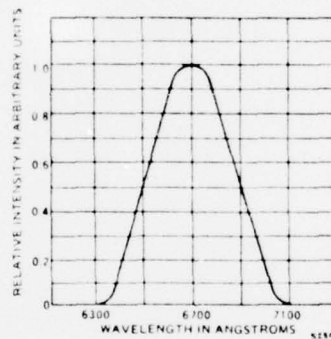

Figure 5 Spectral Distribution

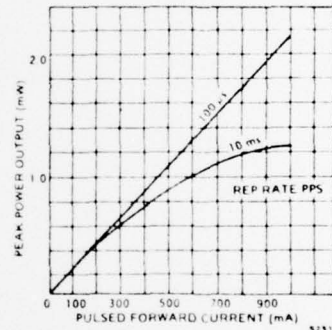

Figure 6 Peak Power Output vs. Pulsed Forward Current

## NOTES

1. As measured with a Photo Research Spectra Spot Brightness Meter with "Spectar" L-175 lens in the brightest region of the emitting surface.
2. The total external power output measurements are made with a Centralab 100C solar cell terminated into a 100 ohm impedance.
3. The apparent spot size diameter for the MV10A, MV10A3, and MV10B, MV10B3 are 0.025-inch minimum to 0.048-inch maximum and 0.025-inch minimum to 0.066-inch maximum respectively.
4. The leads of the MV10B and MV10B3 were immersed in molten solder, heated to 260°C, to a point 1/16-inch from the body of the device per MIL-S-750. Suggested mounting procedures for MV10A and MV10A3: (a) Use wet sponge to heat sink lens when soldering (b) Use conductive epoxy (c) Press fit.

BIBLIOGRAPHIC DATA SHEET	1. Report No. UIUCDCS-R-77-882	2.	3. Recipient's Accession No.
	4. Title and Subtitle OPTOBUNDLE-A Unique Fiber Optic Multiplier		5. Report Date June 1977
7. Author(s) Daniel A. Pitt, Wolfgang J. Poppelbaum, and Christ J. Xydes		8. Performing Organization Rept. No. UIUCDCS-R-882	
9. Performing Organization Name and Address Department of Computer Science University of Illinois at Urbana-Champaign Urbana, IL 61801		10. Project/Task/Work Unit No.	
12. Sponsoring Organization Name and Address Office of Naval Research Arlington, VA 22217		11. Contract/Grant No. N000-14-75-C-0982	
		13. Type of Report & Period Covered Departmental Report	
15. Supplementary Notes		14.	
16. Abstracts This paper describes the design and construction of failsoft single digit decimal multiplier that exhibits almost total immunity to electromagnetic interference. Bundles of glass fiber light guides not only carry the numerical information but actually perform the multiplication as well. Nearly trivial hardware requirements make the device both reliable and inexpensive.			
17. Key Words and Document Analysis. 17a. Descriptors  Optical Fibers Bundle Processing Electro-Optical Multiplication			
17b. Identifiers/Open-Ended Terms			
17c. COSATI Field/Group			
18. Availability Statement Release Unlimited		19. Security Class (This Report) UNCLASSIFIED	21. No. of Pages 28
		20. Security Class (This Page) UNCLASSIFIED	22. Price