

AD-A044 635

HUGHES HELICOPTERS CULVER CITY CALIF
OH-6A TAIL ROTOR TRANSMISSION GREASE EVALUATION AND FAIL DETECT--ETC(U)
JUN 77 B R SMITH, G GRIGORIAN
HH-76-219

F/G 11/8
DAAJ01-70-A-0324
NL

UNCLASSIFIED

TSARCOM-77-2

1 OF 1
ADA044635



END
DATE
FILMED
10-77
DDC

Handwritten circled number: 12

ADA 044635

TSARCOM
REPORT TR 77-2

**OH-6A TAIL ROTOR TRANSMISSION
GREASE EVALUATION AND
FAIL DETECTION SYSTEM TEST**

**B.R. Smith & G. Grigorian
Hughes Helicopter Company
Centinela Ave. at Teale St.
Culver City, CA 90230**

~~██████████~~ JUN 1977
Final Report

APPROVED FOR PUBLIC RELEASE;
DISTRIBUTION UNLIMITED

DDC
RECEIVED
SEP 23 1977
B

Prepared for
**U.S. ARMY TROOP SUPPORT AND
AVIATION MATERIEL READINESS COMMAND**

**Maintenance Engineering Division
4300 Goodfellow Blvd.
St. Louis, MO 63120**



AD No. _____
DDC FILE COPY
410399

UNCLASSIFIED

SECURITY CLASSIFICATION OF THIS PAGE (When Data Entered)

19 REPORT DOCUMENTATION PAGE		READ INSTRUCTIONS BEFORE COMPLETING FORM
1. REPORT NUMBER 18 TSARCOM 77-2	2. GOVT ACCESSION NO.	3. RECIPIENT'S CATALOG NUMBER Sep 72 - Feb 78
6 4. TITLE (and Subtitle) OH-6A Tail Rotor Transmission Grease Evaluation and Fail Detection System Test.	5. TYPE OF REPORT & PERIOD COVERED 9 Final rept. ✓	
	6. PERFORMING ORG. REPORT NUMBER 14 HH-76-219	
10 7. AUTHOR(s) B. R. SMITH G. GRIGORIAN	8. CONTRACT OR GRANT NUMBER(s) 15 DAAJ01-70-A-0324(P20)	
	10. PROGRAM ELEMENT, PROJECT, TASK AREA & WORK UNIT NUMBERS DA Form 3149R Data Item 05-00.5	
11. CONTROLLING OFFICE NAME AND ADDRESS U.S. Army Troop Support and Aviation Materiel Readiness Command, Dir for Maint, ATTN: DRSTS-MEL (2), 4300 Goodfellow Blvd., St. Louis, MO 63120	12. REPORT DATE 11 June 1977	
	13. NUMBER OF PAGES 56	
14. MONITORING AGENCY NAME & ADDRESS (if different from Controlling Office) Commander, US Army Hughes Plant Activity Hughes Helicopter Co., Centinela Ave. at Teale St. Culver City, CA 90230	15. SECURITY CLASS. (of this report) Unclassified	
	15a. DECLASSIFICATION/DOWNGRADING SCHEDULE	
16. DISTRIBUTION STATEMENT (of this Report) Approved for public release; distribution unlimited 12 59p.		
17. DISTRIBUTION STATEMENT (of the abstract entered in Block 20, if different from Report)		
18. SUPPLEMENTARY NOTES		
19. KEY WORDS (Continue on reverse side if necessary and identify by block number) MCG-68-63 Lubricant Test, Heavy Load Lubricant, Anti-wear Lubricant, Lubricant Failure Detector Test.		
20. ABSTRACT (Continue on reverse side if necessary and identify by block number) MCG 68-63 Grease was lab tested in the operation of two OH-6A and two OH-58A tail rotor transmissions. This may be an acceptable lubricant for this application where the transmission is filled to capacity and an increase in temperature (vs. MIL-L-23699) is not objectionable.		

DDC
 RECEIVED
 SEP 23 1977
 RELEVANT
 B

DD FORM 1 JAN 73 1473

EDITION OF 1 NOV 65 IS OBSOLETE

UNCLASSIFIED

SECURITY CLASSIFICATION OF THIS PAGE (When Data Entered)

409164

1B

HH 76-219

FINAL REPORT
ENGINEERING SERVICES CONTRACT
DELIVERY ORDER NO. 0019
TAIL ROTOR TRANSMISSION GREASE
EVALUATION AND FAIL DETECTION SYSTEM TEST

JUNE 1977

CONTRACT DAAJ01-70-A-0324(P20)

HUGHES HELICOPTERS
Culver City, California

SUMMARY

Hughes Helicopters has conducted tests to evaluate the effectiveness of MCG-68-63 heavy load, anti-wear grease in the OH-6A and OH-58 tail rotor transmissions and to test a fail detection system installed on the OH-6A tail rotor transmission.

Two OH-6A tail rotor transmissions were spectrum load tested for 200 hours each. Temperature measurements of the bearings, case, and gear teeth for the grease-filled transmission were higher than those obtained with oil as a lubricant. A no-load dynamic torque test for the transmission which was filled to 98 percent of grease capacity revealed the torque to be approximately four times the value demonstrated when the transmission was filled with oil.

The OH-58 transmission was spectrum load tested for 50 hours. The test results were similar to those obtained with the OH-6A transmission, except that the temperature changes were less. Excessive wear and scoring of the OH-58 transmission gear teeth was noted as a result of the test.

The fail detection system was tested using MCG-68-63 grease in the OH-6A transmission. The system, as tested, did not reliably display the induced failure modes simulated in the test.

The MCG-68-63 grease may be an acceptable lubricant for the tail rotor transmission. An advantage realized for war-time operation is the slow rate of grease loss through a hole approximately 3/4 inch in diameter enabling at least a one hour "get-home" capability.

DDC	A Section <input checked="" type="checkbox"/>
UNANNOUNCED	B. II Section <input type="checkbox"/>
JUSTIFICATION	<input type="checkbox"/>
BY _____	
DISTRIBUTION/AVAILABILITY CODES	
Dist.	AVAIL. and/or SPECIAL
A	

PREFACE

The work documented in this report was performed by Hughes Helicopters, Division of Summa Corporation, Culver City, California for the U.S. Army Aviation Systems Command, St. Louis, Missouri under Delivery Order No. 0019 of OH-6A Engineering Services Contract DAAJ01-70-A-9324(P20).

The tests were accomplished at the Hughes Helicopters Structures Test Laboratory, from September 1972 through February 1976.

TABLE OF CONTENTS

	<u>Page</u>
SUMMARY	1
PREFACE	2
INTRODUCTION	4
DISCUSSION	5
CONCLUSION	14
APPENDIX A HH REPORT NO. 369-BT-1434	16
APPENDIX B MODIFICATION DESIGN DETAILS	48

INTRODUCTIONOBJECTIVE

Hughes Helicopters has conducted tests to evaluate the effectiveness of MCG-68-63 heavy load, anti-wear grease in the OH-6A and OH-58 tail rotor transmissions and to test a fail detection system installed on the OH-6A transmission.

TEST SPECIMEN

Testing was conducted on two serviceable OH-6A tail rotor transmissions (S/N 1271472 and S/N 883071) and one OH-58 transmission, P/N 206-040-400-9 (S/N ALO 55249).

MODIFICATION

The transmissions were modified as follows:

1. Thin sheet metal shields were installed at each bearing for the grease tests.
2. Gear teeth of the OH-6A transmissions were vibro-honed to restore the wear surfaces of the teeth.
3. Thermocouples were installed on all test transmissions.

GREASE

The 6 quarts of MCG-68-63 heavy load anti-wear grease used in the tests were produced by Wright-Patterson AFB USAF Materials Laboratory and provided by the U.S. Army Aviation Systems Command.

FAIL DETECTION SYSTEM

The fail-detection system was procured from Technical Development Company, Glenholden, Pennsylvania. The fail detection system consisted of a sensor that was attached to the test transmission and a remotely located readout panel.

DISCUSSION

TEST SETUP

The test fixture held the transmission in operating position and was capable of applying torque, spectrum loading, additional cooling and constant input speed. See Appendix A for test setup details.

TEST PROCEDURE

The tests were first run with MIL-L-23699 oil in the transmission in order to establish a baseline for comparison (see Table 1). Then the transmissions were cleaned, modified, and packed with grease. Details of the test procedure used to evaluate MCG-68-63 grease in the OH-6A and OH-58 transmission are as described in Appendix A.

Spectrum Load Tests

The first OH-6A transmission was filled approximately 30 percent of capacity (0.32 pound) with grease and the loads in Table 1 were applied. Test grease was added periodically in an attempt to reduce temperatures.

A 200-hour spectrum load endurance test was commenced with the transmission grease at 53 percent of capacity (0.57 pound). Loads of Table 1 were applied. Seven times during test operation the temperature cutoff switch was activated. Each time, after cooling to ambient, the test was resumed.

At the conclusion of the 200 hour test, the transmission was tested another 20 hours with grease being added to maintain a 33°F temperature band within the range of 61° to 109°F above ambient. The transmission contained 98 percent capacity of grease (1.050 pounds).

The second OH-6A transmission was filled with grease to 98 percent of capacity (1.050 pounds) and a 200 hour spectrum load test was conducted. Three times the temperature cutoff switch was activated. Grease which

Table 1. Test Parameters

Lubrication/ Tail Rotor Transmission Type	Load	Input RPM	Output			Time per Cycle	
			RPM	Torque (lb-in.)	HP	Minutes (approx)	Percent (approx)
Oil							
OH-6A	Low	2046	3020	264	13	28.6	53
	Inter	2046	3020	436	21	21.6	40
	High	2046	3020	648	31	3.8	7
						<u>54.0</u>	<u>100%</u>
OH-58	Low	6019	2560	394	16	28.6	53
	Inter	6019	2560	640	26	21.6	40
	High	6019	2560	1538	62.5	3.8	7
						<u>54.0</u>	<u>100%</u>
Grease							
OH-6A	Low	2046	3020	264	13	28.6	53
	Inter	2046	3020	436	21	21.6	40
	High	2046	3020	648	31	3.8	7
						<u>54.0</u>	<u>100%</u>
OH-58	Low	6019	2560	394	16	28.6	53
	Inter	6019	2560	640	26	21.6	40
	High	6019	2560	1538	62.5	3.8	7
						<u>54.0</u>	<u>100%</u>

had exuded from seals was replaced and the test continued to completion.

A pressure transducer was attached to the transmission and a 20 hour period of testing revealed a continuous 3 to 5 psig internal pressure. The grease which had exuded was 0.037 pound. This grease was replaced, the drain plug removed, and testing resumed. In one hour the grease loss was 0.044 pound.

The OH-58 transmission spectrum load test was begun with grease at approximately 50 percent of capacity. Test grease was added periodically to maintain temperatures at no more than 190°F above ambient. Test details are described in Appendix A.

Dynamic Torque Test

The second OH-6A transmission, with 1.050 pounds of grease, was placed in a test setup and no-load dynamic torque was measured at the input shaft. The transmission was voided of grease, 0.40 pint of oil was added, and the test procedure was repeated.

Fail Detection System Test

A fail detection system was installed on the second OH-6A transmission, which was filled with grease to 98 percent of capacity (1.050 pounds). The transmission was subjected to induced failures such as installing scored and spalled gears and damaged gear teeth, and introducing coarse saw chips. Temperatures were increased by turning off the cooling blower.

TEST FINDINGS

Spectrum Load Tests

During spectrum load testing of the OH-6A, temperature measurements of the bearings, case, and gear teeth for the grease filled transmission were higher than those obtained with oil as a lubricant. Gear teeth temperatures were significantly higher in the transmission filled to 53 percent of grease capacity than in the one filled to 98 percent of grease capacity. A one hour spectrum load test conducted on the OH-6A transmission, filled to 98 percent of grease capacity with the drain plug removed, resulted in a 0.044 pound (4 percent) grease loss and a slight decrease of temperature.

The OH-58 spectrum load test results were similar to those obtained with the OH-6A transmission, except that the temperature changes were less than those experienced in the OH-6A spectrum load tests. Excessive wear and scoring of the OH-58 transmission gear teeth was noted as a result of the test.

Temperature comparisons of the OH-6A and OH-58 are shown in Figures 1 and 2, respectively. Test results are described in more detail in Appendix A.

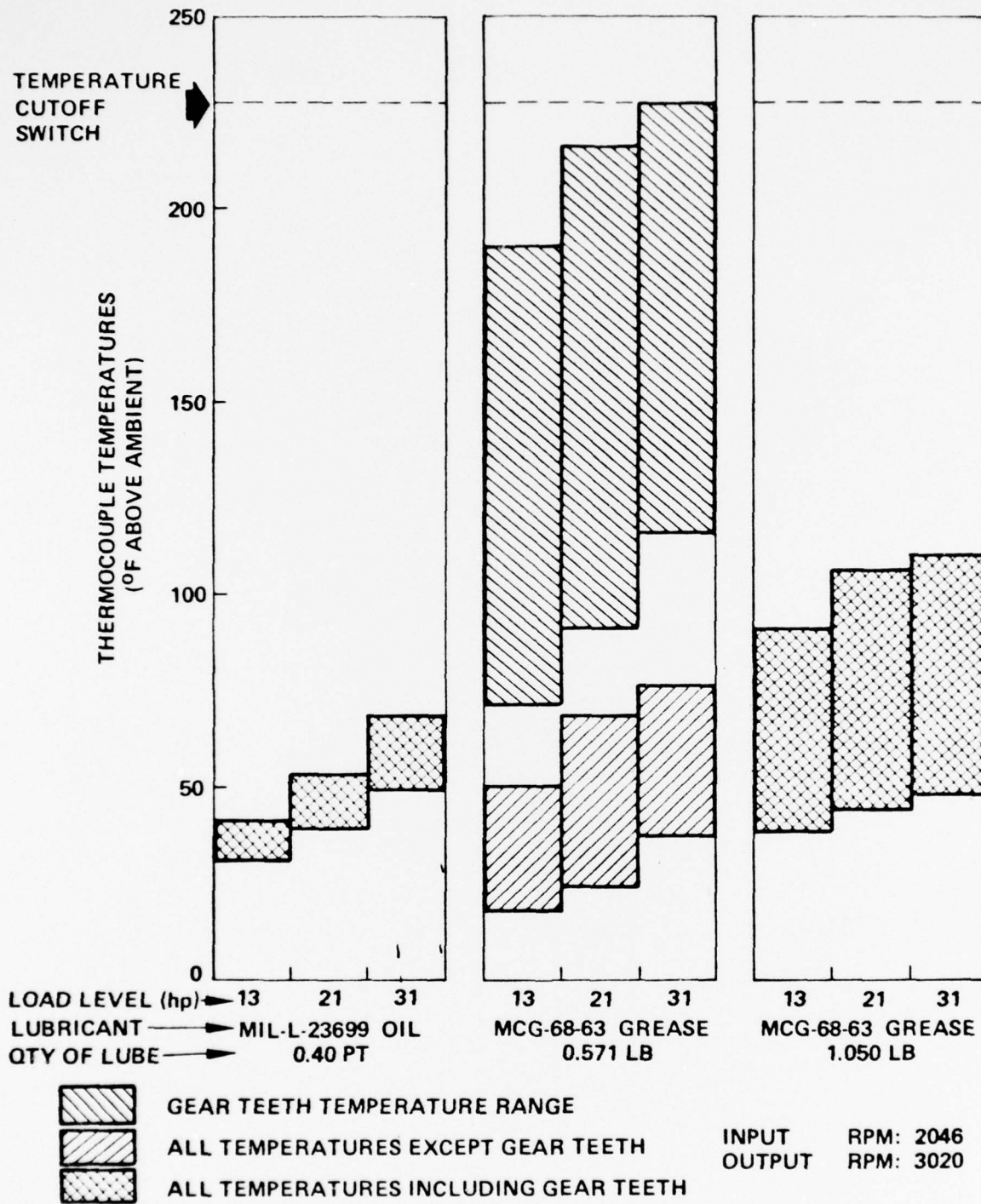

Figure 1. OH-6A Transmission Temperature Comparisons - Grease versus Oil

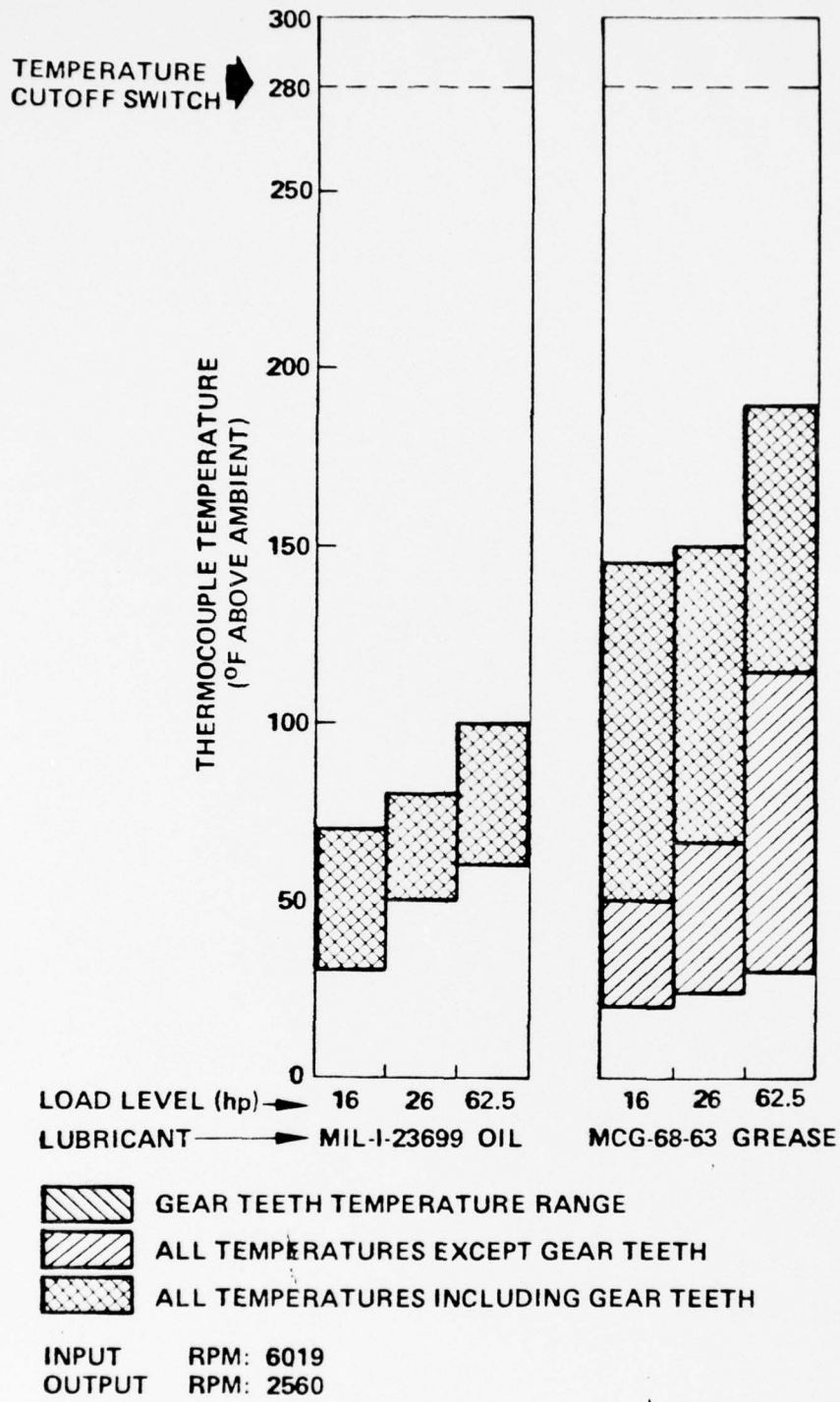
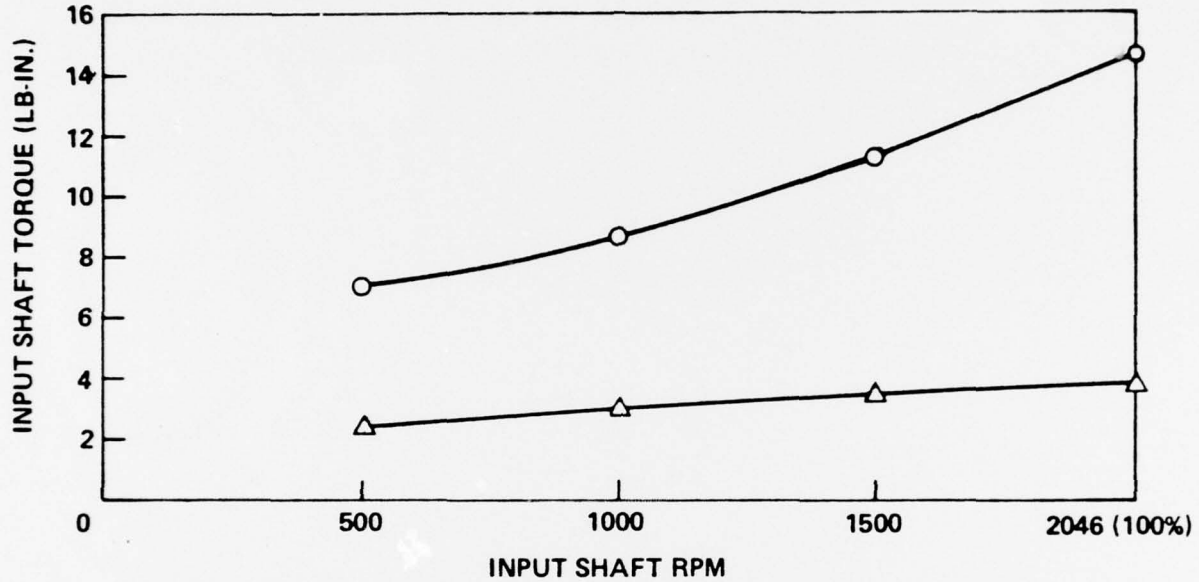

Figure 2. OH-58 Transmission Temperature Comparisons - Grease versus Oil

Dynamic Torque Test

A no-load dynamic torque test for the OH-6A transmission, filled with grease to 98 percent of capacity, revealed the torque to be approximately four times the value demonstrated when the transmission was filled with oil (Figure 3). Test results are described in detail in Appendix A.



○ WITH 1.050 LB MCG-68-63 GREASE △ WITH 0.40 PT MIL-L-23699 OIL

Figure 3. OH-6A Transmission No-Load Dynamic Torque - Grease versus Oil

Fail Detection System Test

The fail detection system, as tested, did not reliably display the induced failure modes simulated in the test, except that the temperature warning light was satisfactory. Test results are detailed in Appendix A.

Stability Time and Temperature

Ten to 15 minutes were required for temperature stabilization of both the oil and the grease.

Gearbox Inspection

The OH-6A gear teeth appeared to be well coated with grease as was the roller bearing on the inboard end of the output gearshaft. The seals on both shafts appeared to have significant wear. The OH-58 gear teeth surfaces showed considerable wear and scoring indicating that the grease was pushed out at contact points. Grease discoloration was very evident. Higher temperatures apparently caused no thermal damage. See photographs in Appendix A.

MODIFICATION DESIGNS

Shields

Thin sheet metal shields required at each bearing are shown in Figures 4 and 5 for the OH-6A and OH-58, respectively. Detail sketches of the shields are in Appendix B. Assembly and disassembly of the OH-58 shields required shop aid tools. Detail drawings are found in Appendix B.

Thermocouples

Thermocouples were installed for testing as follows:

1. On the inboard end of two teeth of the output gear
2. As near to the outer race of each bearing as practical
3. On the outside of the housing in the vicinity of each bearing
4. In the lubricant near the input gear by the drain plug.

Locations of thermocouples are shown in Figures 4 and 5 for the OH-6A and OH-58, respectively.

Cover

The OH-58 required a cover in order to retain the grease during test. Location of this cover is shown in Figure 5 and the detail drawing is in Appendix B.

Fail Detection System

Installation of the fail detection system requires modification to the OH-6A transmission housing as shown in detail drawings in Appendix B.

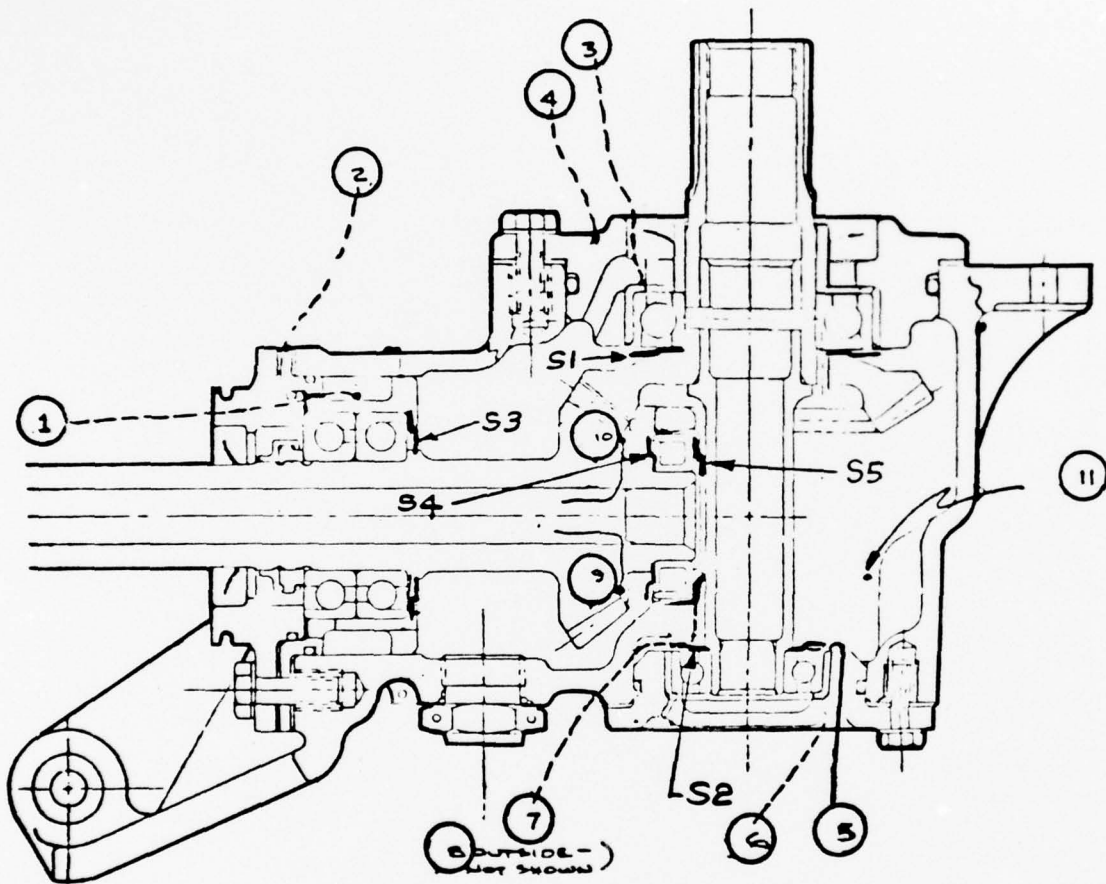

$S_1, S_2, \text{etc.} = \text{SHIELDS}$

$(1), (2), \text{etc.} = \text{THERMOCOUPLE}$

Figure 4. Thermocouple and Shield Locations - OH-6A Transmission

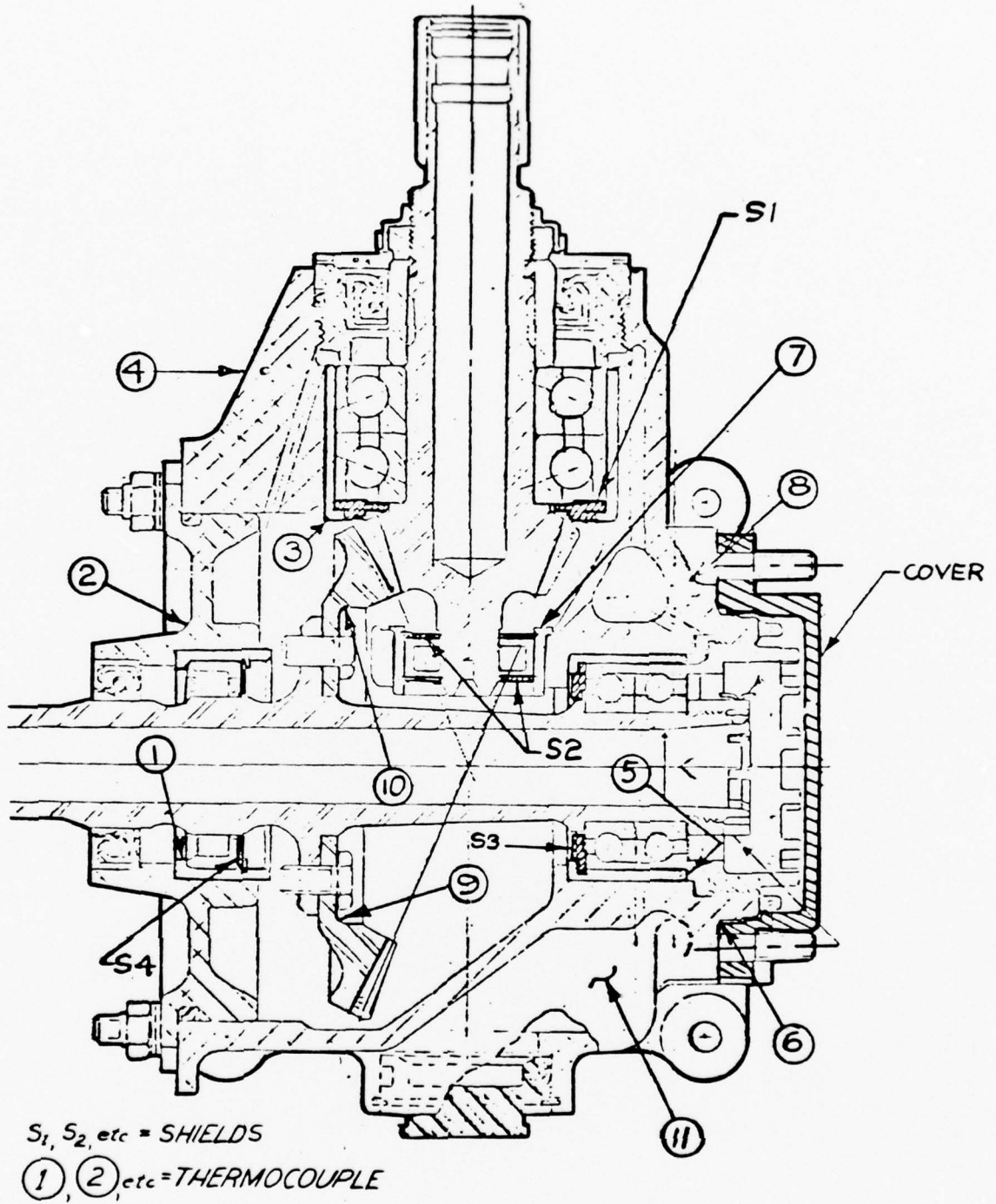

Figure 5. Thermocouple, Shield, and Cover Locations - OH-58 Transmission

CONCLUSIONS

The substitution of MCG-68-63 heavy load, anti-wear grease for the MIL-L-23699 oil now used is acceptable as a lubricant in both the OH-6A and the OH-58 tail rotor transmissions. However, both transmissions would have to be modified to a greater extent than they were for the test.

The shaft seals on both the OH-6A and the OH-58 leaked throughout the test at a rate of about 0.037 pound per 20 hours. The grease loss is not significant but deposits of grease around the shaft seals, drive couplings, and swashplates would be undesirable in that there would be an additional attraction of abrasive particles, thus accelerating the wear of drive components adjacent to the transmissions. Also, the breather on the OH-6A transmission would have to be redesigned as there is a constant undesirable internal pressure of 3 to 5 psig.

When packed to 98 percent of the housing capacity, the OH-6A transmission internal temperatures stabilized in the normal operating temperature range of 38° to 110°F above ambient. However, the grease that had leaked through the seals had to be replaced three times during the 200 hour test in order to keep the temperature within safe parameters below 110°F above ambient temperature. From past experience, it has been learned that temperatures exceeding the 110°F above ambient may cause accelerated wear to the gear teeth, and if the temperature is allowed to exceed 228°F above ambient immediate thermal damage will result.

The average increase in temperature of the OH-6A transmission when using MCG-68-63 grease over the MIL-L-23699 oil is 83 percent when the transmission is packed within 98 percent of its capacity. When the transmission is packed to 53 percent of its capacity, there is a 15 percent rise in temperature on all parts of the transmission except the gear teeth. This temperature becomes divergent as the 31 horsepower level is approached.

The average increase in temperature of the OH-58 transmission, including gear teeth temperature, increased 76 percent when the transmission was packed with MCG-68-63 grease instead of MIL-L-23699 oil.

The OH-6A no-load torque values increased from 2.2 to 7.0 pound-inches at an input shaft rpm of 500 and from 3.75 to 14.8 pound-inches at 2046 rpm when replacing the MIL-L-23699 oil with MCG-68-63 grease.

The fail detection system, when used with grease, proved to be unable to detect metal chips from gears that were purposely damaged and was unreliable even when 0.5 gram of gear chips was introduced into the transmission.

The use of MCG-68-63 grease would allow a one hour "get-home" capability should the bottom of the case be punctured with a hole approximately 3/4 inch in diameter, as there was a loss of only 0.044 pound of grease in this time and the internal temperatures dropped 15° to 20°F as the internal pressure was released.

APPENDIX A
REPORT NO. 369-BT-1434
TAIL ROTOR TRANSMISSION GREASE EVALUATION
AND FAIL DETECTION SYSTEM TEST

Hughes Helicopters

REPORT NO. 369-BT-1434

TAIL ROTOR TRANSMISSION GREASE EVALUATION
AND FAIL DETECTION SYSTEM TEST

September 1974

Revised April 1976

PREP. BY

B. R. Smith
B. R. Smith

G. Grigorian
G. Grigorian

APPROVED BY

K. B. Amer
K. B. Amer

M. I. Leib
M. I. Leib

J. C. Dandy
J. C. Dandy

R. E. Moore
R. E. Moore

Hughes Helicopters

1

REPORT TITLE <u>Grease Evaluation and Fail Detection System Test</u>	REPORT NO <u>369-BT-1434</u>
PREPARED BY <u>G. Grigorian</u>	SUBJECT <u>TAIL ROTOR TRANSMISSION</u>
CHECKED BY <u>G. D. Deveaux</u>	MODEL NO <u>OH-6A and OH-58</u>

TABLE OF CONTENTS

<u>SECTION</u>	<u>PAGE</u>
Summary	11
List of Illustrations and Tables	111
1.0 INTRODUCTION	1
2.0 TEST OBJECTIVE	2
3.0 DISCUSSION	2
3.1 TEST SPECIMEN	2
3.2 TEST SETUP	3
3.3 TEST PROCEDURE	3
3.4 TEST RESULTS	8
3.5 CONCLUSIONS	10
3.6 TEST WITNESSES	11
Appendix	28
Distribution	Last

REVISED

Hughes Helicopters

11

REPORT TITLE	Grease Evaluation and Fail Detection System Test	REPORT NO	369-BT-1434
PREPARED BY	G. Grigorian	SUBJECT	MODEL NO OH-6A and OH-58
CHECKED BY	G. D. Deveaux	TAIL ROTOR TRANSMISSION	

SUMMARY

Tests were conducted to evaluate the effectiveness of MCG-68-63, heavy load, anti-wear grease in the OH-6A and OH-58 tail rotor transmissions and to test a fail detection system installed on the OH-6A transmission.

Two OH-6A tail rotor transmissions, with vibro honed gears (53 percent and 98 percent full of grease) were spectrum load tested for 200 hours each. All bearing, case and gear teeth temperatures were higher than those obtained with oil as a lubricant and the gear teeth temperature in the transmission that was 53 percent full of grease was significantly higher.

A one hour spectrum load test with the drain plug removed from the OH-6A transmission resulted in a 0.044 pound (4 percent) grease loss and a slight decrease of temperatures.

No-load dynamic torque tests revealed the torque, with grease in the transmission, to be approximately four times that with oil.

A fail detection system was tested using MCG-68-63 grease in the OH-6A transmission. The system, as tested, did not reliably display the induced failure modes simulated in the test.

The OH-58 transmission was spectrum load tested with 2.20 lbs. of MCG-68-63 grease for 50 hours. The test results were similar to those obtained with the OH-6A transmission, except that the temperature changes were less than those experienced in the OH-6A spectrum load tests. Excessive wear and scoring of the gear teeth was noted as a result of the tests.

REVISED

Hughes Helicopters

iii

REPORT TITLE	Grease Evaluation and Fail Detection System Test	REPORT NO.	369-BT-1434
PREPARED BY	G. Grigorian	SUBJECT	MODEL NO. OH-6A and OH-58
CHECKED BY	G. D. Deveaux	TAIL ROTOR TRANSMISSION	

LIST OF ILLUSTRATIONS AND TABLES

<u>Figure</u>		<u>Page</u>
1	Temperature Comparisons - Grease Versus Oil, OH-6A Transmission	12
2	No-Load Dynamic Torque - Grease Versus Oil, OH-6A Transmission	13
3	Temperature Comparison - Grease Versus Oil, OH-58 Transmission	14
4	Thermocouple and Shield Locations, OH-6A Transmission	15
5	Thermocouple and Shield Locations, OH-58 Transmission	16
6	Test Setup and Instrumentation, OH-6A Transmission	17
7	Test Setup, Oh-58 Transmission	18
8	First Transmission Output Gearshaft and Housing (OH-6A)	19
9	Grease Leakage at, Seals of Second Transmission (OH-6A)	20
10	Output Gearshaft of Second Transmission (OH-6A)	21
11	Output Gearshaft Cavity and Seal Cover of Second Transmission(OH-6A)	22
12	Input Gearshaft and Cavity of Second Transmission(OH-6A)	23
13	Aft End of Input Gearshaft Cavity and Cover of Second Transmission (OH-6A)	24
14	Fail Detection System Instrumentation and Sensor	25
15	Input Gearshaft, OH-58 Transmission	26
16	Grease Discoloration, Output Gearshaft and Cavity, OH-58 Transmission	27

REVISED

Hughes Helicopters

1

REPORT TITLE	Grease Evaluation and Fail Detection System Test	REPORT NO	369-BT-1434
PREPARED BY	G. Grigorian	SUBJECT	MODEL NO. OH-6A and OH-58
CHECKED BY	G. D. Deveaux	TAIL ROTOR TRANSMISSION	

1.0 INTRODUCTION

This report concerns a grease evaluation and fail detection system test on the OH-6A and OH-58 tail rotor transmissions. These tests were conducted from September 1972 to February 1976 in the Hughes Helicopters' Structures Test Laboratory, Culver City, California.

Hughes Helicopters

2

REPORT TITLE <u>Grease Evaluation and Fail Detection System Test</u>	REPORT NO <u>369-BT-1434</u>
PREPARED BY <u>G. Grigorian</u>	SUBJECT <u>TAIL ROTOR TRANSMISSION</u>
CHECKED BY <u>G. D. Deveaux</u>	MODEL NO <u>OH-6A and OH-58</u>

2.0 TEST OBJECTIVE

The objective of these tests, performed on two OH-6A and one OH-58 tail rotor transmissions, was to (a) evaluate MCG-68-63 heavy load anti-wear grease as a lubricant; (b) determine grease flow rate from a hole in the transmission housing; (c) compare the no-load dynamic torque of grease versus oil; and, (d) test a fail detection system installed thereon.

3.0 DISCUSSION

3.1 Test Specimen - Testing was conducted on two serviceable 369A5400-601 tail rotor transmissions (S/N 1271472 and S/N 883071) and one OH-58 transmission, P/N 206-040-400-9 (S/N ALO 55249). They are modified as follows:

1. Thin sheet metal shields were installed at each bearing for the grease tests as shown in Figures 4 and 5.
2. Both gears of the 369A5400-601 transmissions were vibro-honed to restore the wear surfaces of the teeth.
3. On all test transmissions thermocouples were installed:
 - (a) on the inboard end of two teeth of the output gear,
 - (b) as near to the outer race of each bearing as practical,
 - (c) on the outside of the housing in the vicinity of each bearing and (d) in the lubricant near the input gear by the drain plug. The thermocouple locations are shown in Figures 4 and 5.

The MCG-68-63 heavy load anti-wear grease used in the tests was produced by Wright Patterson AFB's USAF Materials Laboratory and provided by the U. S. Army Aviation Systems Command.

REVISED

Hughes Helicopters

3

REPORT TITLE <u>Grease Evaluation and Fail Detection System Test</u>	REPORT NO <u>369-BT-1434</u>
PREPARED BY <u>G. Grigorian</u>	SUBJECT <u>TAIL ROTOR TRANSMISSION</u>
CHECKED BY <u>G. D. Deveaux</u>	MODEL NO <u>OH-6A and OH-58</u>

The fail detection system procured from Technical Development Company, Glenholden, Pennsylvania, consisted of a sensor that attached to the test transmission and a remote located readout panel.

3.2 Test Setup - The test setup consisted of the following:

1. A fixture that held the test transmission in its normal operating position.
2. A hydraulic motor, attached to the input shaft of the test transmission by means of a mechanical speed reducer, that maintained a constant input shaft speed.
3. A belt-driven hydraulic pump, connected to the transmission output shaft, that allowed the required torque to be applied.
4. A programmed relief valve, downstream of the hydraulic pump, that provided the required spectrum loading to be applied to the transmission.
5. A large air blower, directed at the test transmission, to maintain the stabilized temperatures, with oil, less than 120^oF above ambient.
6. Instrumentation to monitor the input shaft speed, applied torque, and thermocouple temperatures.

3.3 Test Procedure

- #### 3.3.1 OH-6A Transmission - The OH-6A transmissions each containing 0.40 pint of MIL-L-23699 oil, were installed one at a time in the test setup and were run at load levels shown in Figure 1, to obtain the stabilized temperatures for comparison with those of the grease. Air cooling, provided by a large blower, was added to maintain all temperatures lower than 120^oF above ambient. Blower speed remained constant (26.5 ft/sec air velocity) for all subsequent testing.

Hughes Helicopters

4

REPORT TITLE	Grease Evaluation and Fail Detection System Test	REPORT NO	369-BT-1434
PREPARED BY	G. Grigorian	SUBJECT	MODEL NO OH-6A and OH-58
CHECKED BY	G. D. Deveaux	TAIL ROTOR TRANSMISSION	

After obtaining the stabilized temperatures with oil the transmissions were removed from the test setup, disassembled, and cleaned. Shields were added to the bearings. The bearings were packed with MCG-68-63 grease and the transmissions were reassembled.

The first transmission (S/N 1271472) to undergo testing was filled approximately 30 percent full with the test grease and installed in the test setup. Spectrum loading was commenced. Test grease was added periodically, during the first few hours of testing, in an attempt to reduce the output gear teeth temperatures which were erratic and well above the other temperatures.

A 200-hour spectrum load endurance test was commenced with 0.571 pounds of test grease in the transmission (53 percent full). All recorded temperatures, except the gear teeth, remained in a 36° F band that varied between 18° and 76° F above ambient. Temperature of the output gear teeth varied between 71° and 228° F ambient. Seven times during the test a temperature cutoff switch, set at the upper limit, was activated by the gear teeth temperature and the test was restarted each time after cooling to ambient temperature.

At the conclusion of the 200-hour test, additional grease was added until all temperatures remained in a 33° F band that varied from 61° to 109° F above ambient, and testing was resumed for another 20 hours. The transmission contained 1.050 pounds of the test grease (98 percent full).

REVISED

Hughes Helicopters

5

REPORT TITLE	Grease Evaluation and Fail Detection System Test	REPORT NO	369-BT-1434
PREPARED BY	G. Grigorian	SUBJECT	MODEL NO OH-6A and OH-58
CHECKED BY	G. D. Deveaux	TAIL ROTOR TRANSMISSION	

A 200-hour spectrum load test was then conducted on the second OH-6A tail rotor transmission (S/N 883071) containing 1.050 pound (98 percent full) of the test grease. All recorded temperatures remained in a 50°F band that varied between 38° and 110°F above ambient. Three times during the 200-hour test the output gear teeth temperatures exceeded their normal running temperature (107°F, 147°F and 147°F above ambient). The test was stopped each time and grease was observed to have exuded from the shaft seals. The first time this occurred, the output shaft seal was replaced with a new seal but the grease continued to exude from the seal. The amount of grease lost each time (0.042, 0.025 and 0.095 pound) was added to the transmission and testing resumed with the output gear teeth returning to their normal operating temperature.

A pressure transducer attached to this transmission for a 20-hour period of testing revealed a continuous 3 to 5 psig internal pressure.

The 0.037 pounds of grease that had exuded from the shaft seals at the end of the 20-hour test was added to the transmission, and it was subjected to an additional two hours of testing. The drain plug was removed for the second hour of this test resulting in a loss of 0.044 pound of grease. Approximately 80 percent of this quantity was ejected, under pressure, upon removal of the drain plug. All temperatures were observed to drop 15° to 20°F with the drain plug removed, remaining between 42° and 72°F above ambient throughout this hour.

Both transmissions were disassembled and inspected following the above tests. Findings are reported in the Test Results section of this report.

Hughes Helicopters

6

REPORT TITLE <u>Grease Evaluation and Fail Detection System Test</u>	REPORT NO. <u>369-BT-1434</u>
PREPARED BY <u>G. Grigorian</u>	SUBJECT <u>TAIL ROTOR TRANSMISSION</u>
CHECKED BY <u>G. D. Deveaux</u>	MODEL NO. <u>OH-6A and OH-58</u>

The second transmission (S/N 883071) was reassembled with 1.050 pounds of the test grease installed and placed in a setup to measure the no-load dynamic torque at the input shaft. Following this, the transmission was cleaned and 0.40 pint of MIL-L-23699 oil was installed and the same procedure repeated. The no-load dynamic torque with grease was approximately four times that obtained with the oil (see Figure 2).

A fail detection system, supplied by Technical Development Company of Glenholden, Pennsylvania, was installed and tested on the second transmission with 1.050 pounds of MIL-G-83363 grease installed therein.

After 20 hours of spectrum load testing the transmission gears were replaced with a set that was scored and spalled. After testing an additional eight hours, with no indication of failure, the output gearshaft was removed and several gear teeth were purposely damaged.

After testing an additional eight hours, with no indication of gear teeth failure, 0.5 gram of coarse saw chips (from another OH-6A output gearshaft) were introduced directly above the input gear. Within 30 seconds after approximately 50 percent of the chips were introduced, the chip warning light began to flicker. The remainder of the chips were introduced resulting in sporadic and intermittent lighting of the chip warning light on the first four threshold levels during two hours of spectrum load testing.

The temperature warning light feature of the proposed fail detection system was satisfactorily demonstrated on the first three threshold levels by temporarily shutting off the air cooling blower.

REVISED

Hughes Helicopters

7

REPORT TITLE	Grease Evaluation and Fail Detection System Test	REPORT NO.	369-BT-1434
PREPARED BY	G. Grigorian	SUBJECT	MODEL NO. OH-6A and OH-58
CHECKED BY	G. D. Deveaux	TAIL ROTOR TRANSMISSION	

On one occasion during testing of the scored and spalled gears, an 80°F temperature rise was recorded from the thermocouples on the output gear teeth, however, the fail detection system sensor indicated a decrease in temperature. After replacing the 0.037 pound of grease that had exuded from the output shaft seal, the thermocouple and sensor temperatures returned to their normal operating values.

Each time the required electrical power was applied to the fail detection unit, the chip warning light was observed to remain on at all threshold levels. This light would go off after 3 to 15 minutes.

Modification of the electrical circuitry corrected the latter problem, however, testing with a larger sensor (0.65 diameter) revealed no significant improvements.

3.3.2 OH-58 Transmission - The test procedure outlined in the preceding paragraph was repeated on the OH-58 transmission. The specimen containing its normal capacity of MIL-L-23699 oil was installed in the test setup as shown in Figure 7, and was run at the load levels shown in Figure 3, to obtain the stabilized temperatures for comparison with those of the grease. The specimen was then removed from the test setup, disassembled, and cleaned. The shields shown in Figure 5 were added to the bearings. The bearings were packed with MCG-68-63 grease and the specimen was reassembled.

The transmission was filled approximately 50 percent full with test grease and was installed in the test setup and was subjected to spectrum loading, as follows:

Hughes Helicopters

REPORT TITLE <u>Grease Evaluation and Fail Detection System Test</u>	REPORT NO <u>369-BT-1434</u>
PREPARED BY <u>G. Grigorian</u>	SUBJECT <u>MODEL NO OH-6A and OH-58</u>
CHECKED BY <u>G. D. Deveaux</u>	TAIL ROTOR TRANSMISSION

<u>Input RPM</u>	<u>Output RPM</u>	<u>Load Spectrum</u>	<u>Output Torque Lb.-In</u>	<u>Output H.P.</u>	<u>Time Mins. Appx.</u>	<u>Time Percent Appx.</u>
6019	2560	Low	394	16	28.6	53%
6019	2560	Inter.	640	26	21.6	40%
6019	2560	High	1538	62.5	3.8	7%
					54.0	100%

Test grease was added periodically during the first few hours of testing to reduce the output gear teeth temperatures to no more than 190° above ambient.

A 50-hour spectrum load endurance test was commenced with 2.20 pounds of test grease in the transmission. During the endurance test all recorded temperatures, except the gear teeth, varied between 20°F to 160°F above ambient. The gear temperatures varied between 50°F to 190°F above ambient (see Figure 3).

3.4 Test Results

3.4.1 OH-6A Transmission - Removal of the gears from the OH-6A transmissions, at the conclusion of the endurance tests, resulted in the following visual observations:

1. The gear teeth appeared to be well coated with grease (see Figures 8, 10 and 12)
2. The roller bearing on the inboard end of the output gearshaft appeared to be adequately coated with grease (see Figures 8 and 10).
3. The seals on both shafts appeared to have significant wear.

REVISED

Hughes Helicopters

9

REPORT TITLE	Grease Evaluation and Fail Detection System Test	REPORT NO	369-BT-1434
PREPARED BY	G. Grigorian	SUBJECT	MODEL NO OH-6A and OH-58
CHECKED BY	G. D. Deveaux	TAIL ROTOR TRANSMISSION	

4. Grease discoloration was very evident, changing from ivory at the beginning, to black (in the transmission 53 percent full) and to grayish olive drab (in the transmission 98 percent full) at the conclusion of testing (see Figure 10)
5. No signs of distress or other discrepant observations were apparent.

Use of the MCG-68-63 grease as a lubricant resulted in higher temperatures than when tested with MIL-L-23699 oil (see Figure 1).

A marked increase in gear teeth temperatures resulted when the transmission was less than approximately 98 percent full of the grease (see Figure 1).

Removal of the 3/4-16 threaded drain plug, for one hour of spectrum load testing, resulted in a loss of 0.044 pound of grease and a slight decrease in temperatures.

Testing performed with the transmission approximately 98 percent full of grease resulted in an internal housing pressure of 3 to 5 psig.

Ten to fifteen minutes were required for temperature stabilization for both the oil and the grease.

No-load dynamic torque tests with the grease (98 percent full) resulted in values approximately four times those with the oil (see Figure 2).

Introduction of 0.5 gram of gear chips with 1.050 pounds of grease in the transmission, resulted in sporadic and intermittent flashing of the "chip warning" light on the fail detection system.

REVISED

Hughes Helicopters

10

REPORT TITLE Grease Evaluation And Fail Detection System Test REPORT NO 369-BT-1434
PREPARED BY G. Grigorian SUBJECT TAIL ROTOR TRANSMISSION MODEL NO OH-6A and OH-58
CHECKED BY G. D. Deveaux

Loss of 0.037 pound of grease from the transmission resulted in an increase in temperature of the output gear teeth but a decrease in temperature was indicated by the fail detection system.

3.4.2 OH-58 Transmission - Disassembly of the specimen at the conclusion of the 50-hour spectrum test resulted in the following observation.

1. The gear teeth and bearing surfaces and housing cavities appeared to be adequately coated with grease (see Figures 15 and 16).
2. Grease discoloration from ivory to gray and black is shown in Figure 16.
3. Considerable amount of wear and scoring was noted on the gear teeth surfaces indicating that the grease was pushed out at the contact points due to excessively high test loads.

3.5 Conclusions - From the foregoing tests it may be concluded that:

1. The MCG-68-63 heavy load anti-wear grease may be an acceptable lubricant for the tail rotor transmission.
2. When the transmission is less than approximately 98 percent full of grease, the gear teeth temperatures will increase significantly.
3. Only a small amount of grease would be lost in one hour if a fingersize hole developed in the transmission housing.
4. The loss of a small amount of grease has little, if any, effect on the transmission temperatures within an hour after the loss occurs.
5. The current shaft seals permit the loss of grease.
6. The fail detection system, as tested, does not reliably display the simulated failure modes of the transmission.

REVISED

Hughes Helicopters

11

REPORT TITLE	Grease Evaluation and Fail Detection System Test	REPORT NO	369-BT-1434
PREPARED BY	G. Grigorian	SUBJECT	OH-6A and OH-58
CHECKED BY	G. D. Deveaux	TAIL ROTOR TRANSMISSION	

3.6 Test Witnesses

H. E. Sawicki	Supervisor, Drive System Design Group - AAH
F. L. Aikens	AAH Component Test Program Senior Engineer
H. P. Swanson	Engineering Technician, USAHPA/SAVHUE
G. K. Dingle	Project Engineer, OH-6A

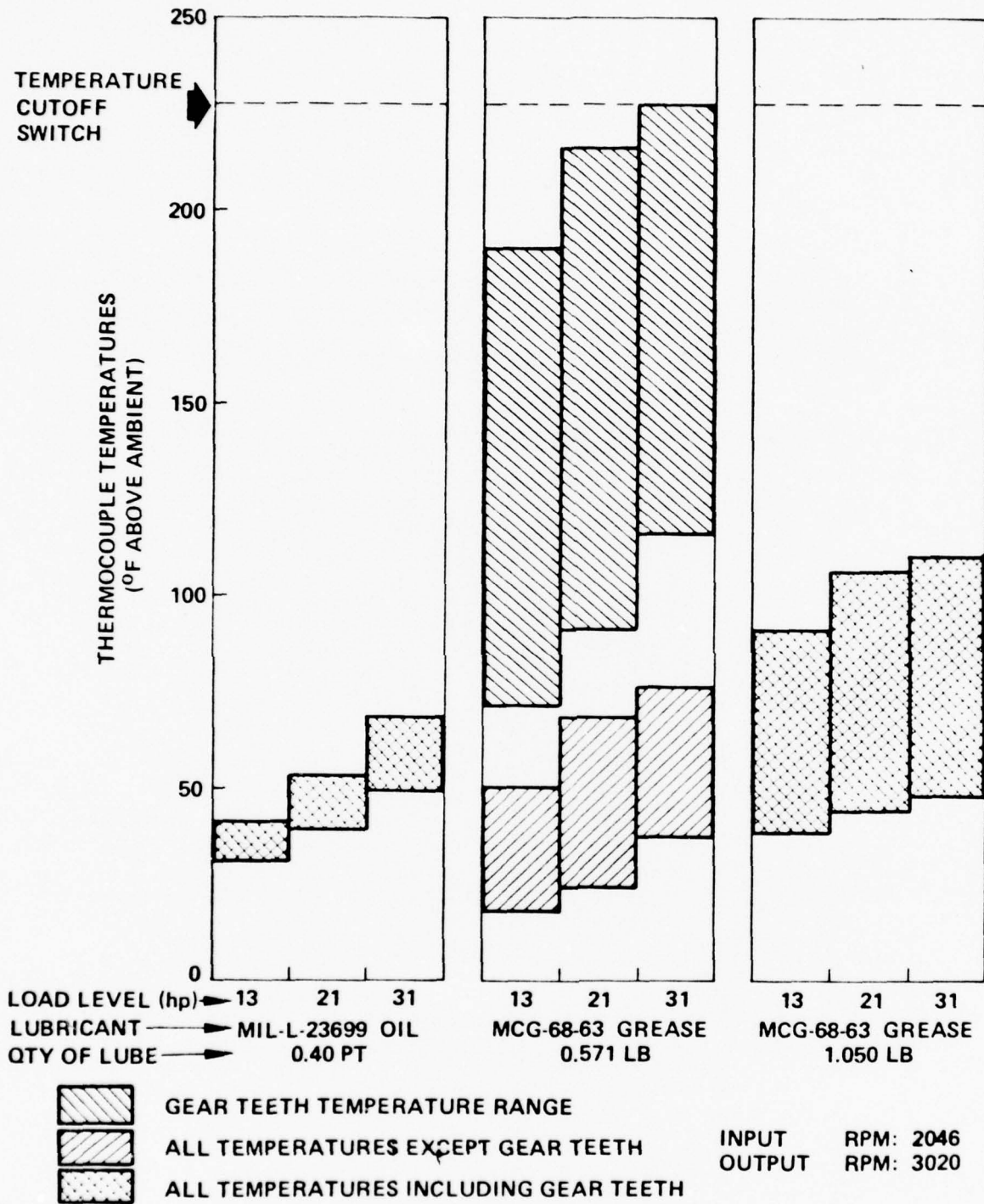

Figure 1. OH-6A Transmission Temperature Comparisons - Grease versus Oil

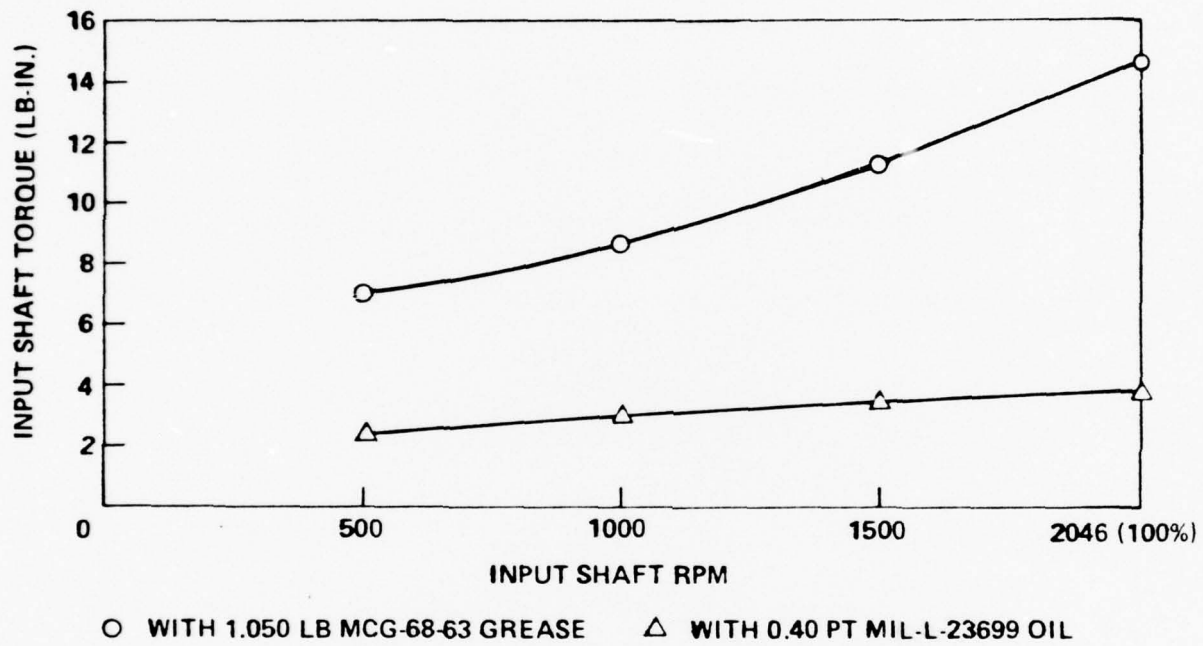
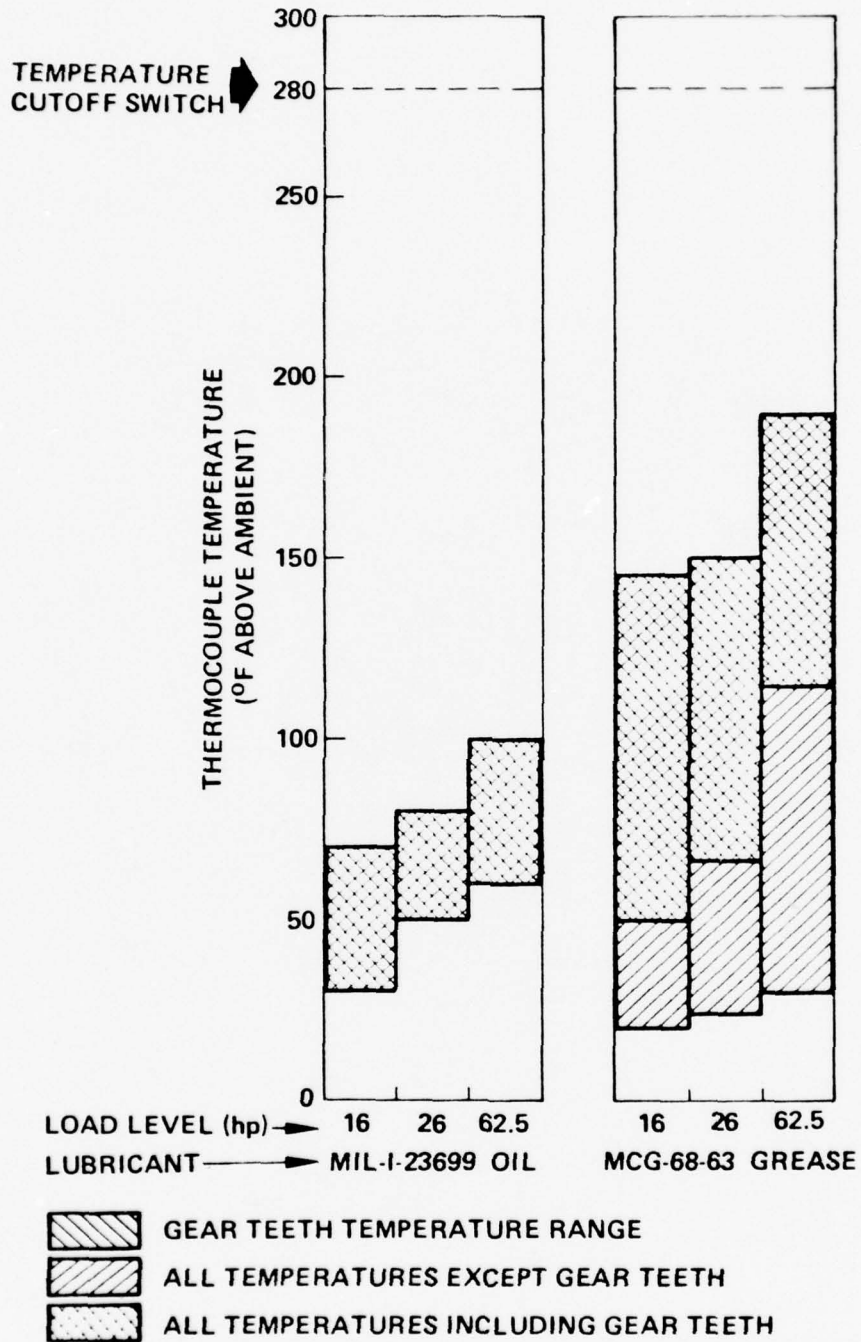

Figure 2. OH-6A Transmission No-Load Dynamic Torque - Grease versus Oil



INPUT RPM: 6019
OUTPUT RPM: 2560

Figure 3. OH-58 Transmission Temperature Comparisons - Grease versus Oil

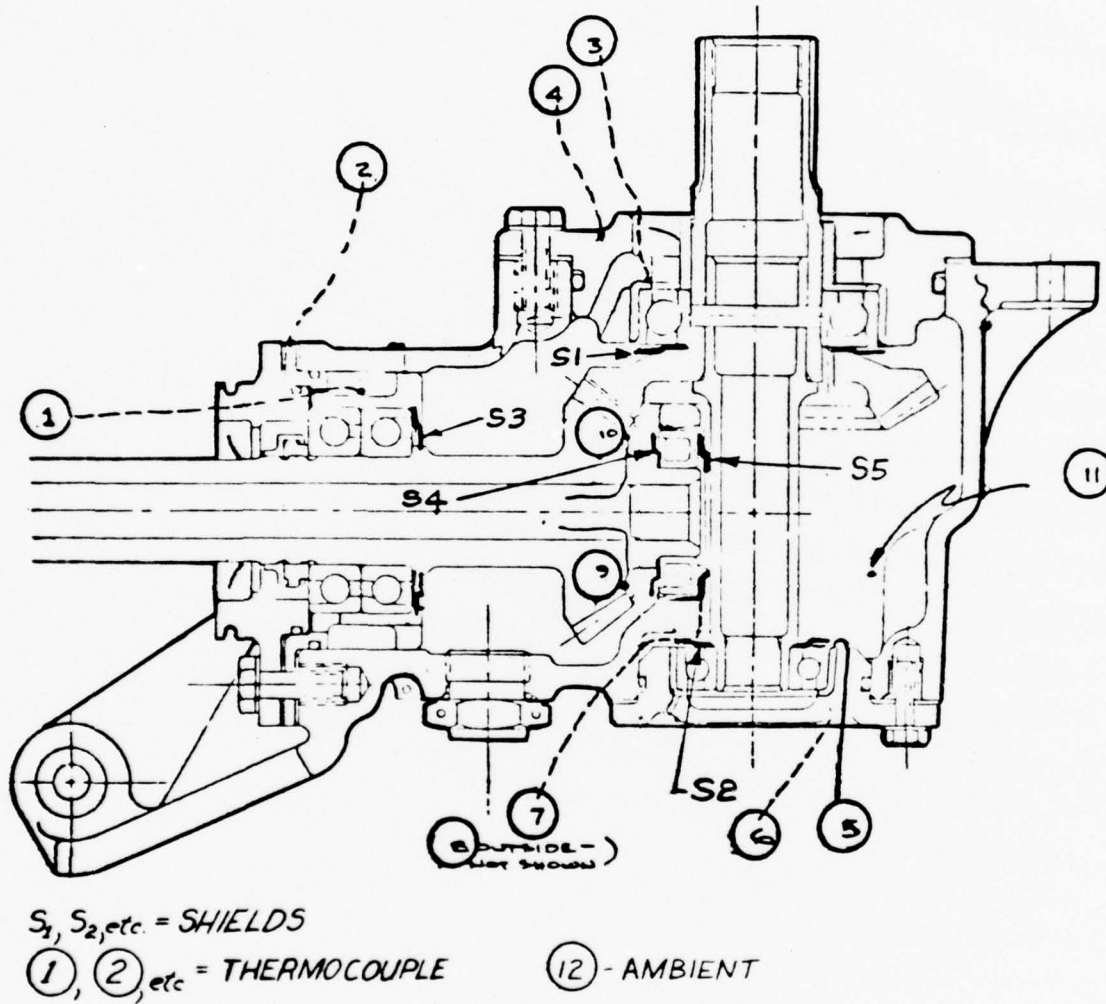

Figure 4. Thermocouple and Shield Locations -
OH-6A Transmission

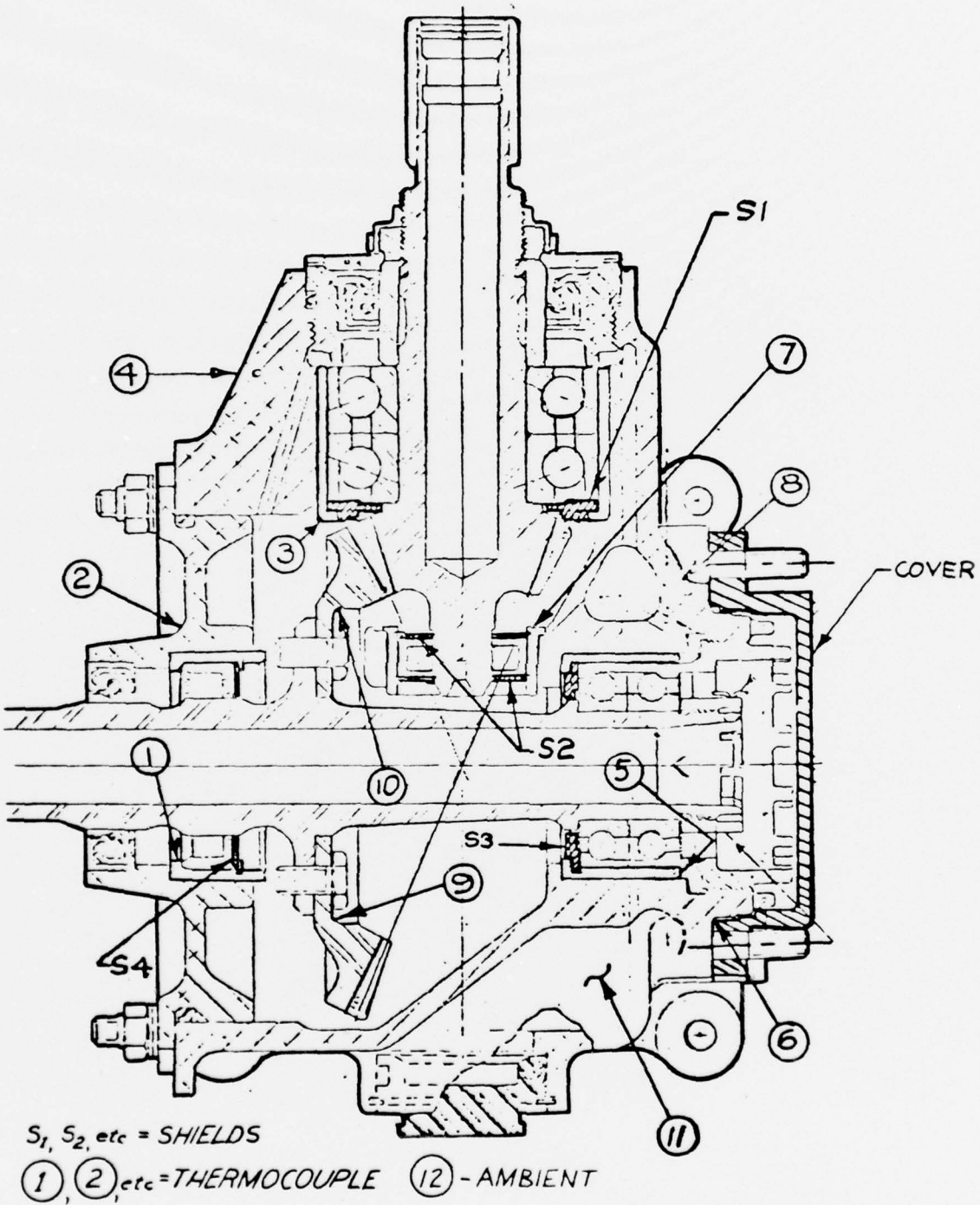

Figure 5. Thermocouple, Shield, and Cover Locations - OH-58 Transmission

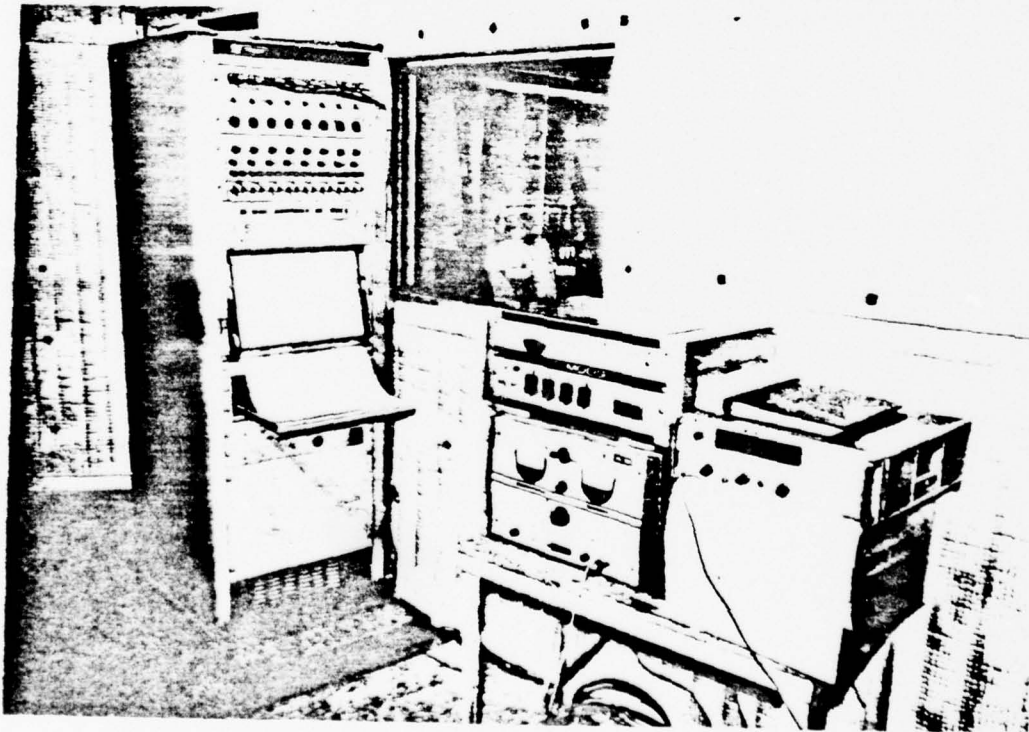
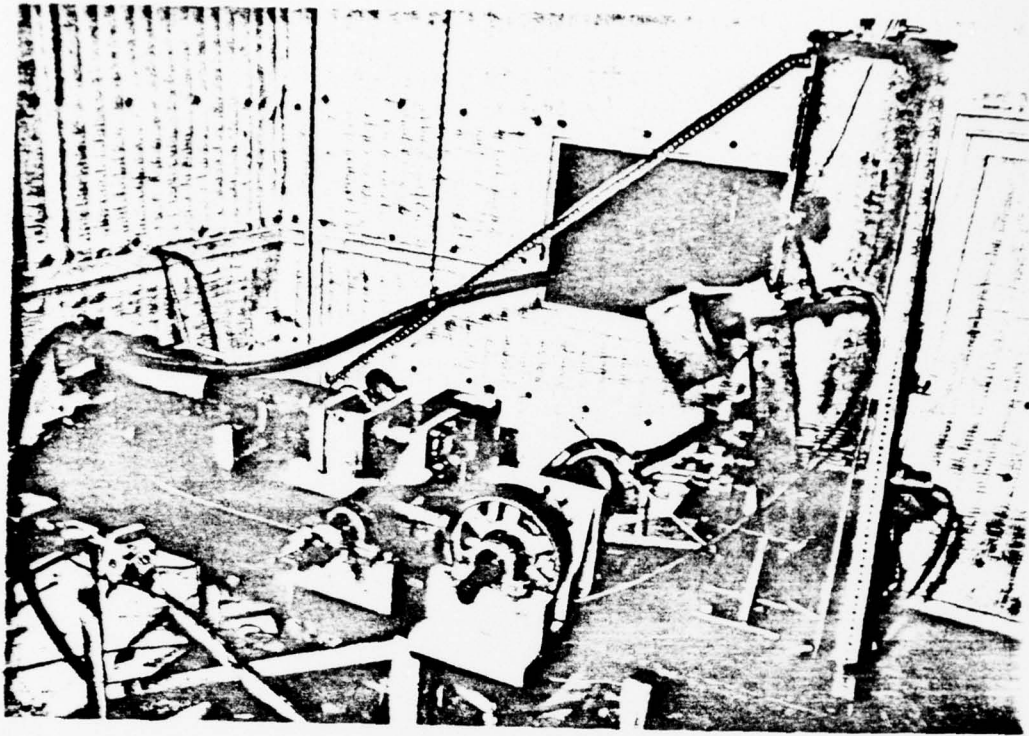

Figure 6. Test Setup and Instrumentation

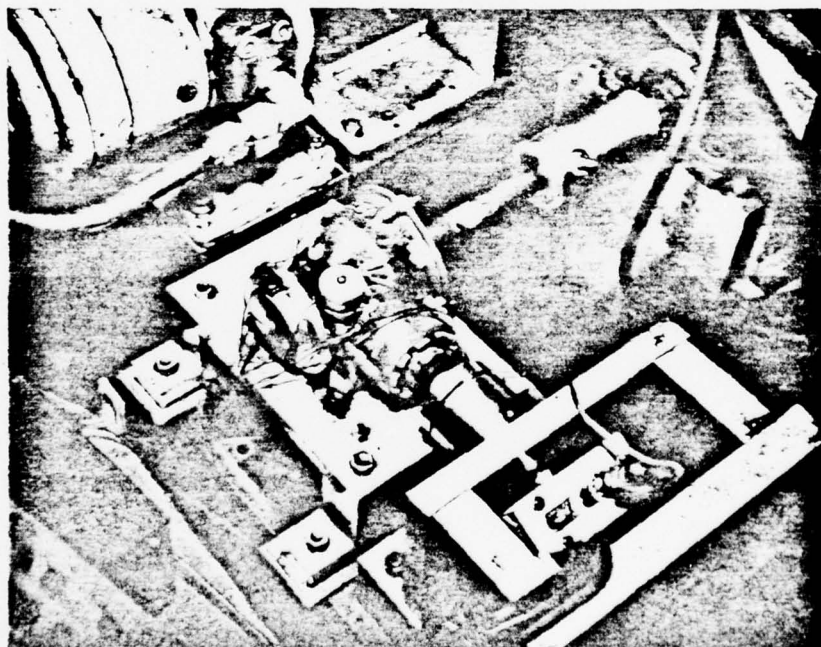
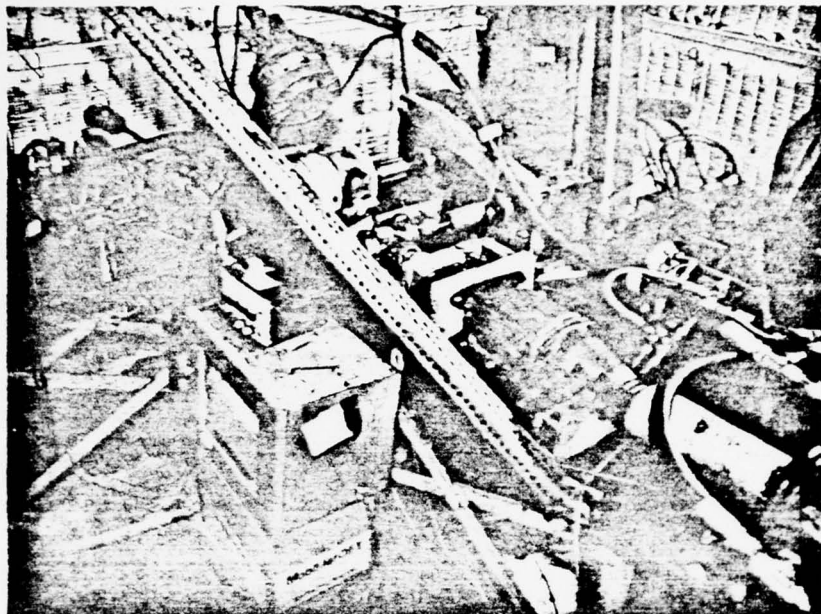

Figure 7. Test Setup, OH-58 Transmission

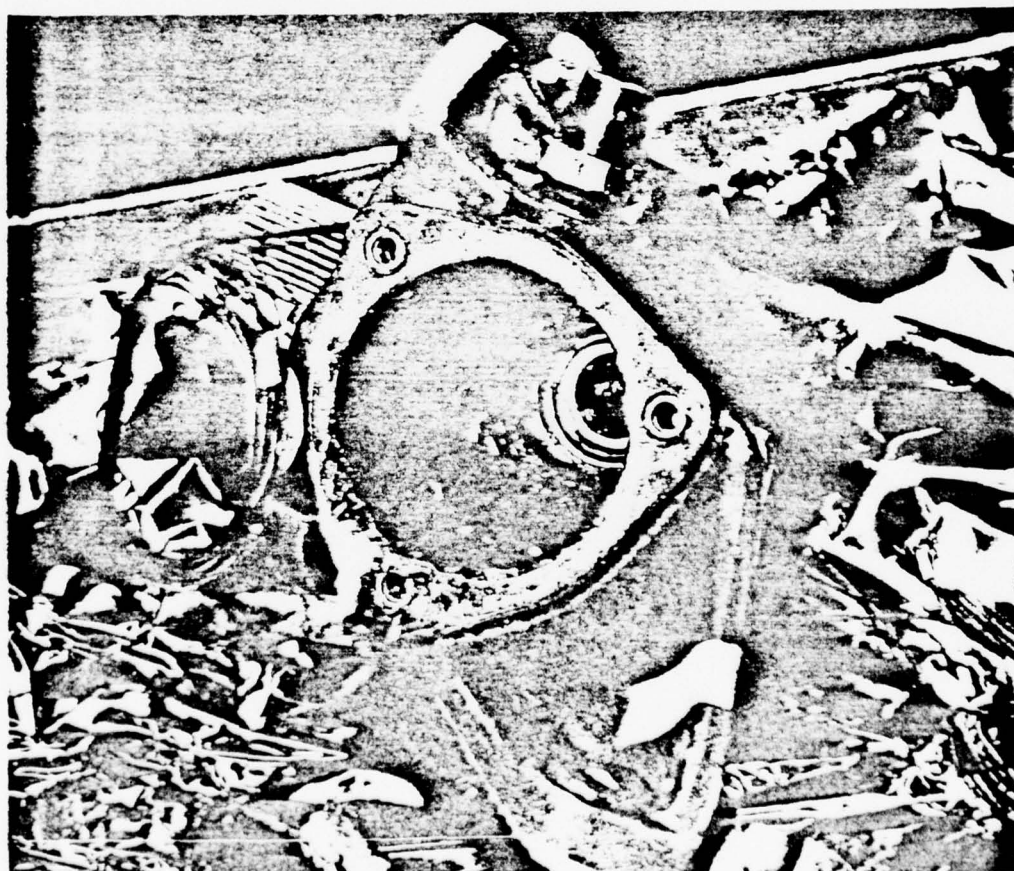

Figure 8. First Transmission Output Gearshaft and Housing
(OH-6A)

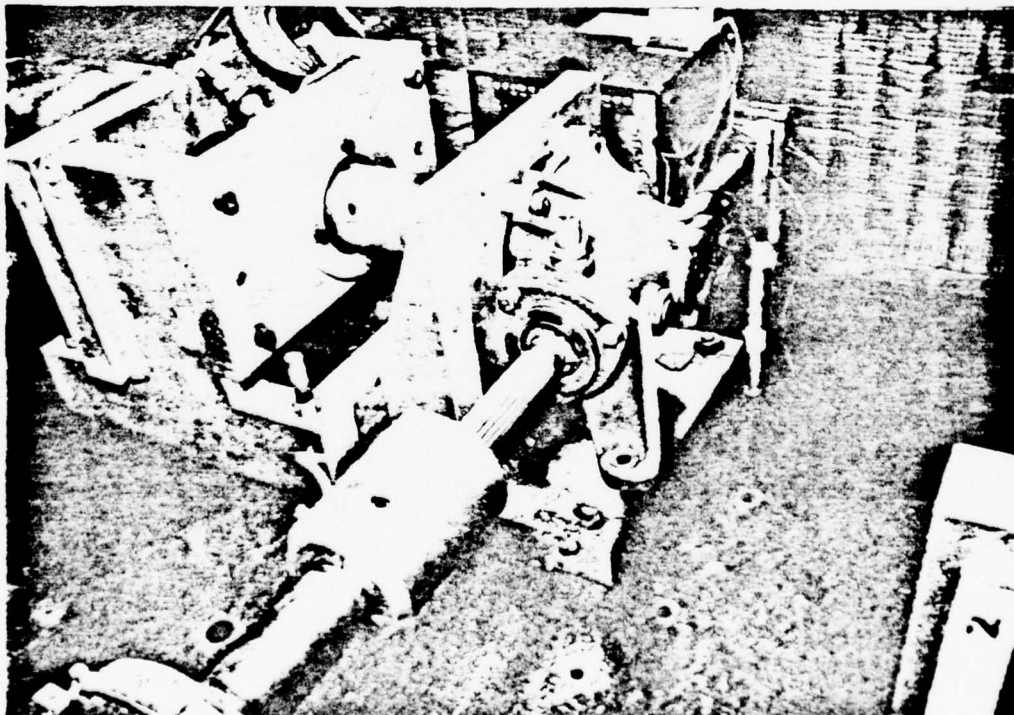
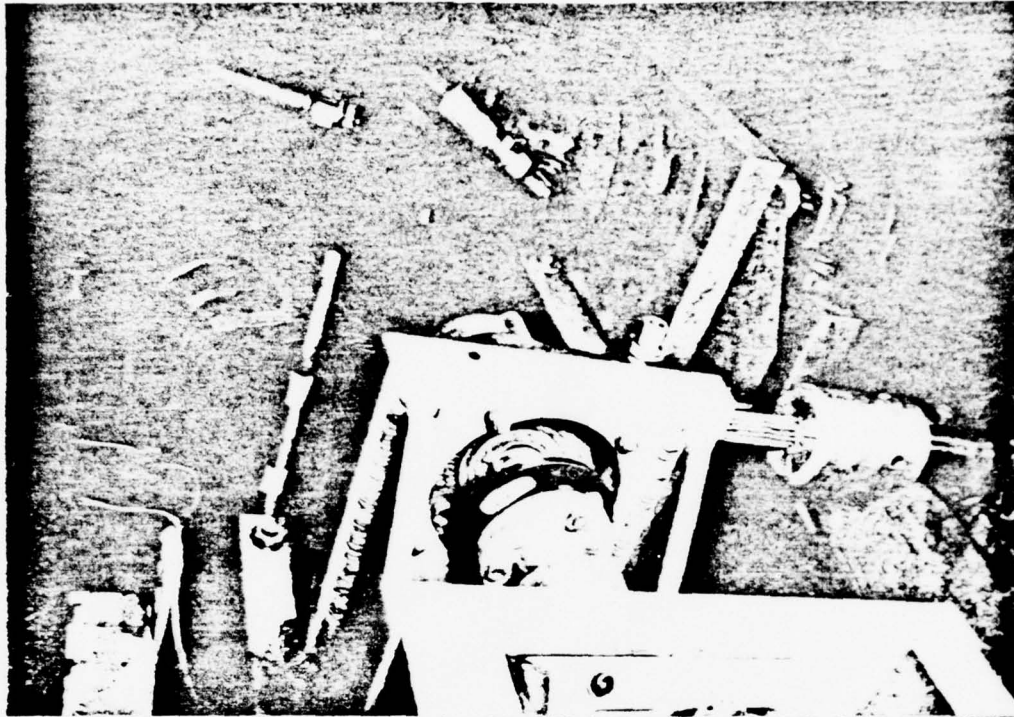

Figure 9. Grease Leakage at Seals of Second Transmission

(OH-6A)

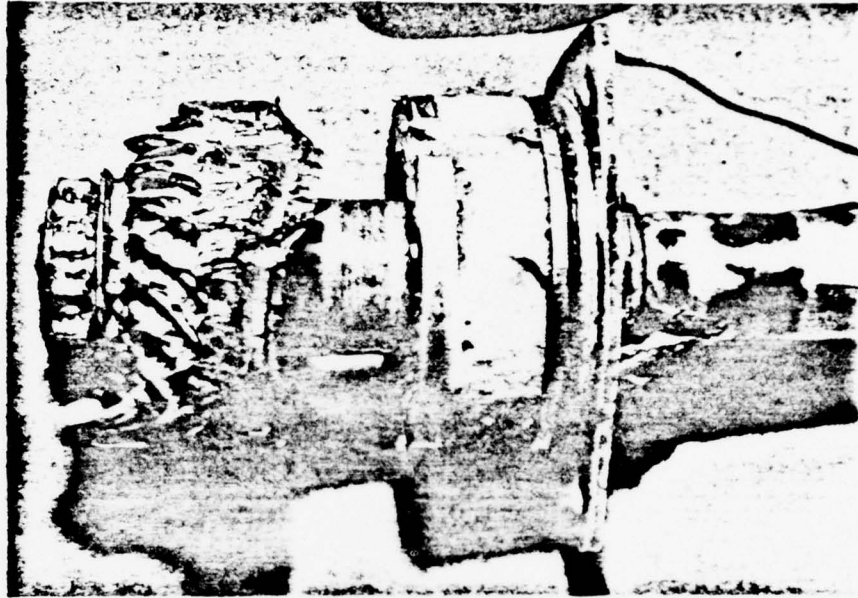

Figure 10. Output Gearshaft of Second Transmission
(OH-6A)

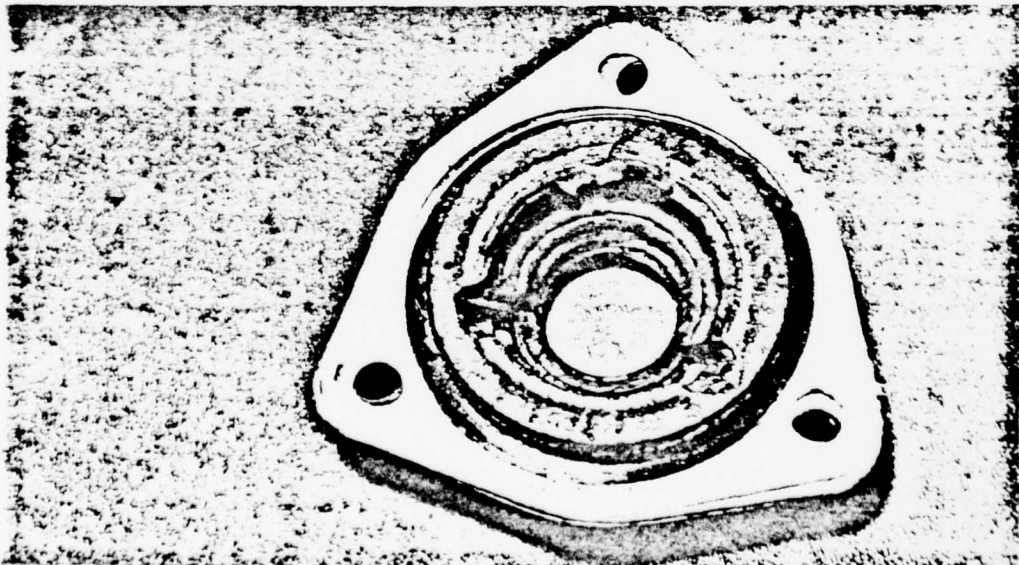
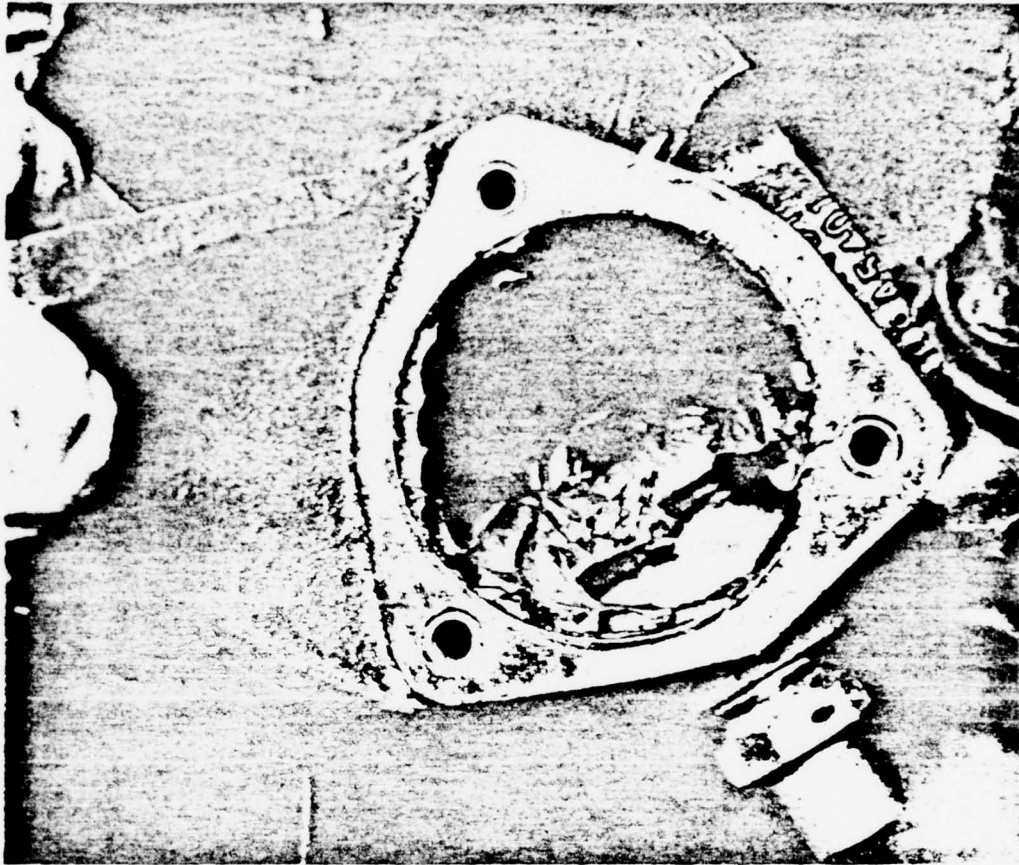

Figure 11. Output Gearshaft Cavity and Seal Cover
of Second Transmission

(OH-6A)

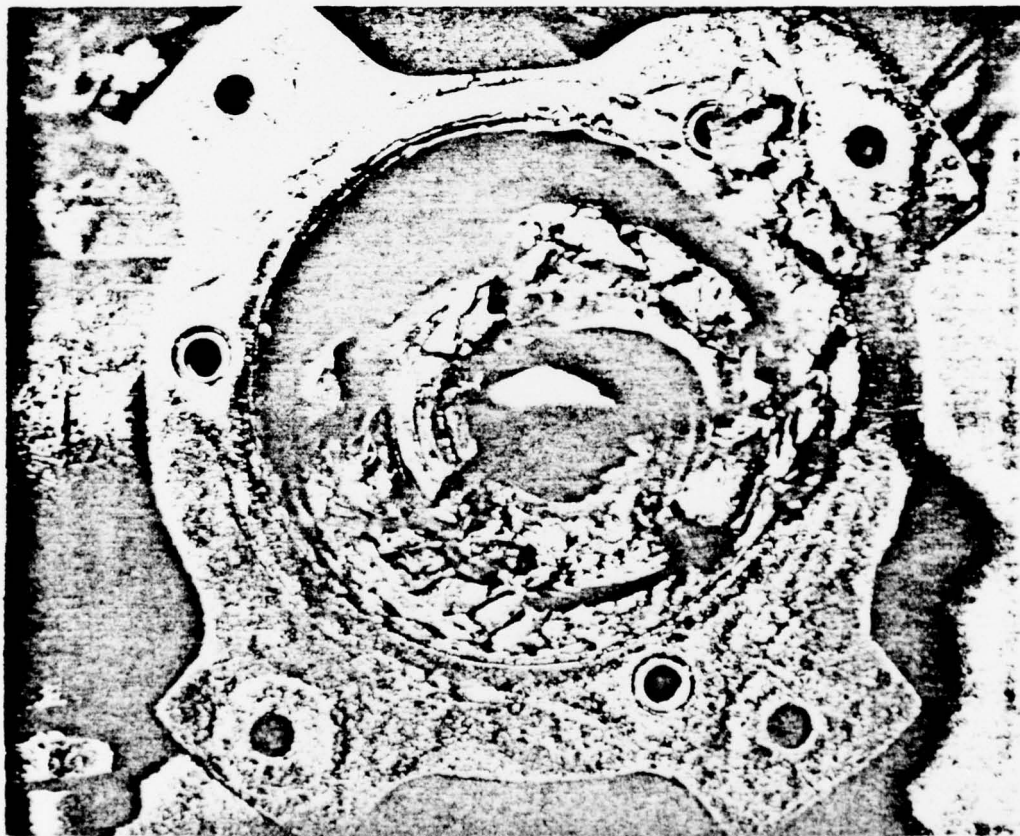

Figure 12. Input Gearshaft and Cavity of Second Transmission
(OH-6A)

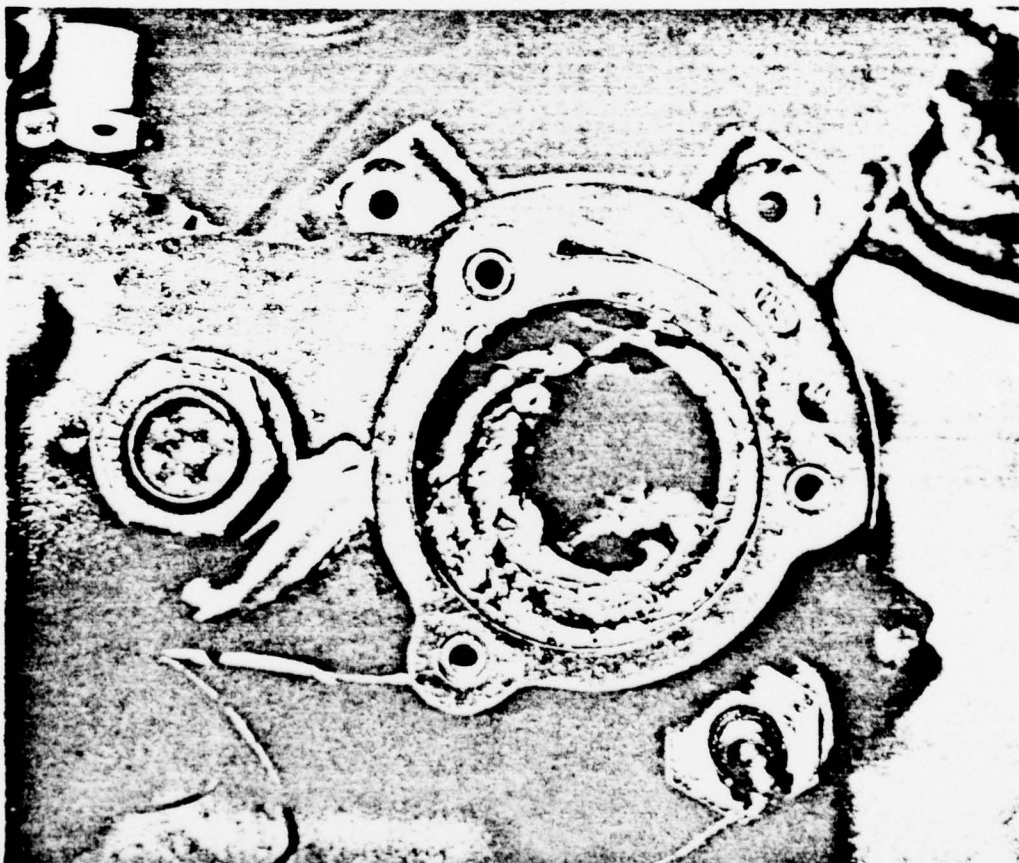
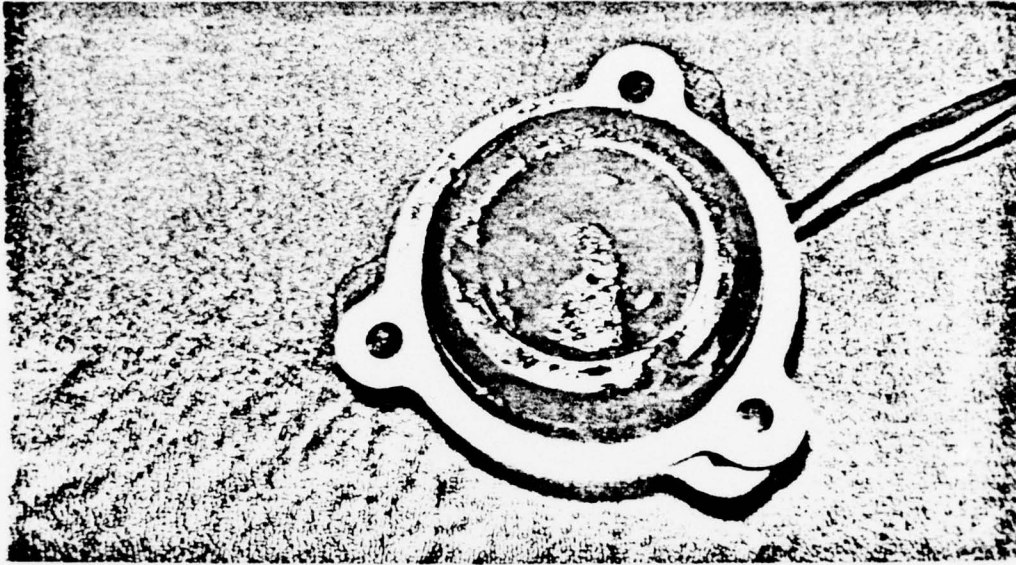

Figure 13. Aft End of Input Gearshaft Cavity and
Cover of Second Transmission
(OH-6A)

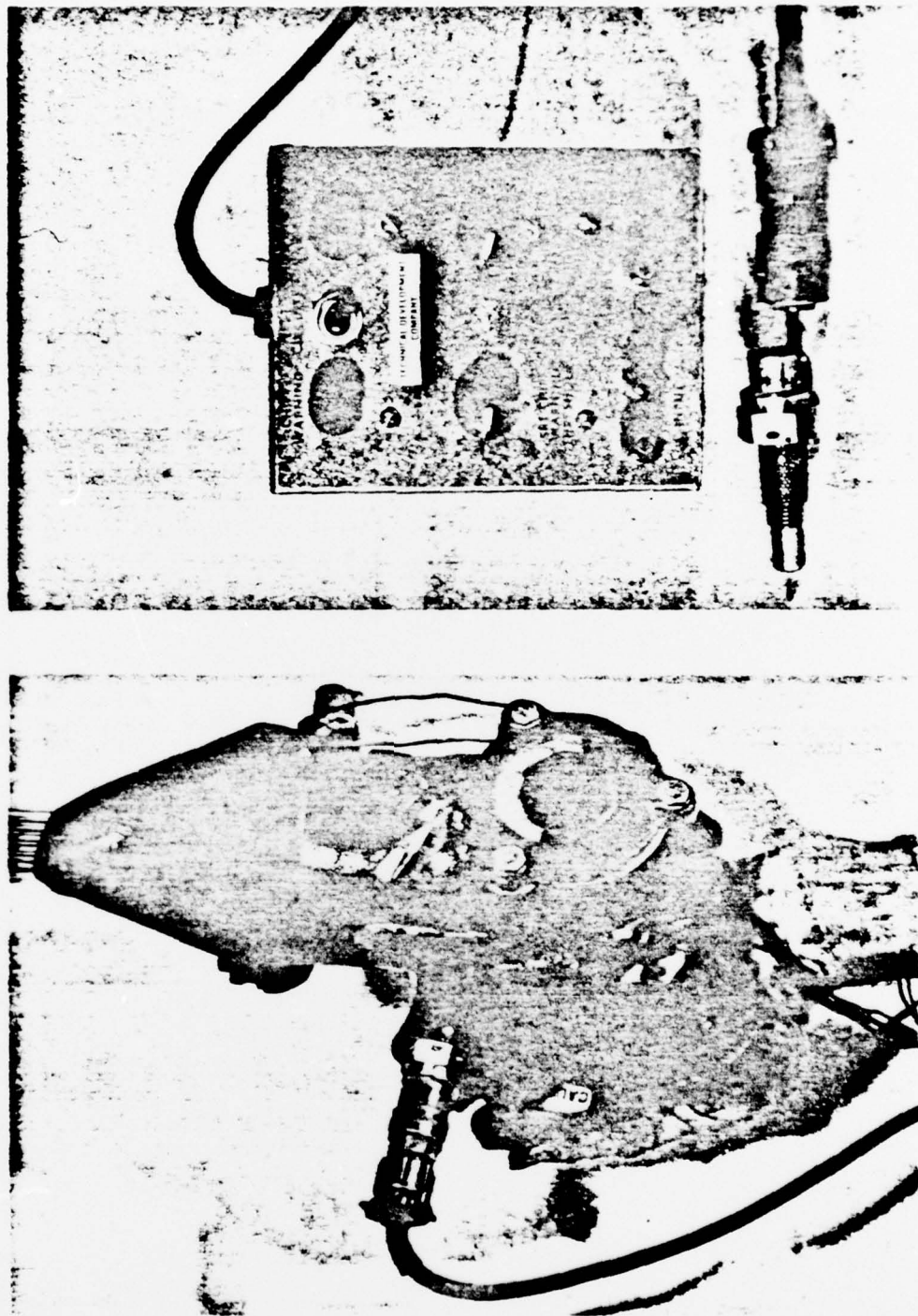

Figure 14. Fail Detection System Instrumentation and Sensor



Figure 15. Input Gear Shaft, OH-58 Transmission



Figure 16. Grease Discoloration, Output Gear Shaft and Cavity,
OH-58 Transmission

APPENDIX B
MODIFICATION DESIGN DETAILS

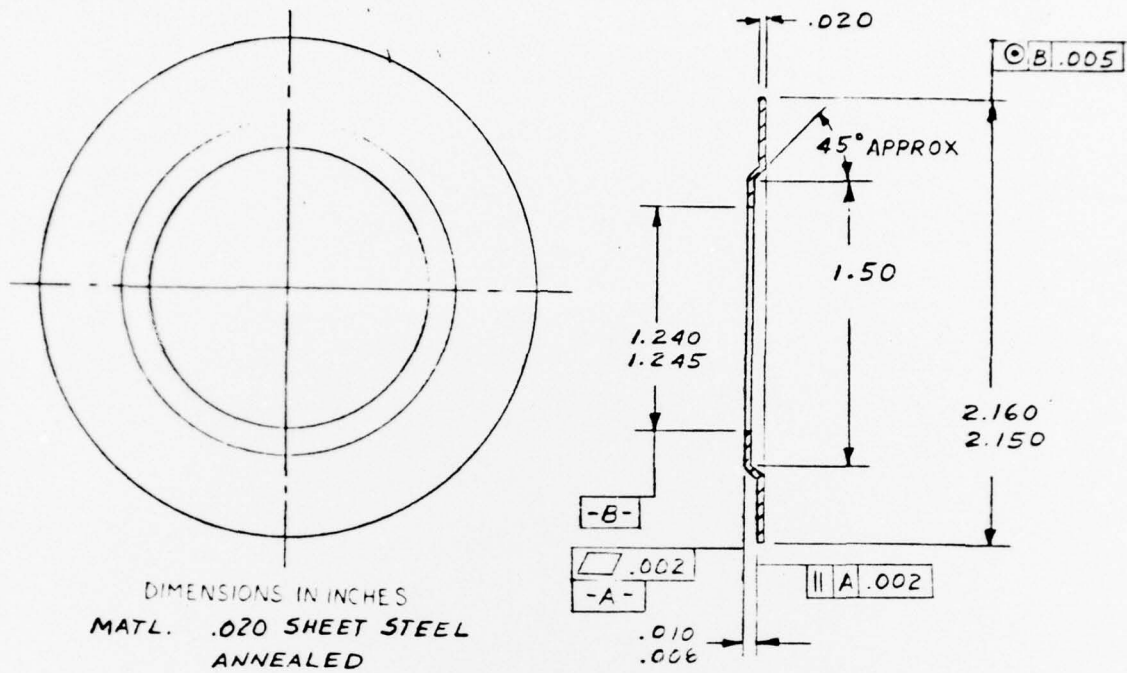

Figure B-1. OH-6A Shield Number S1

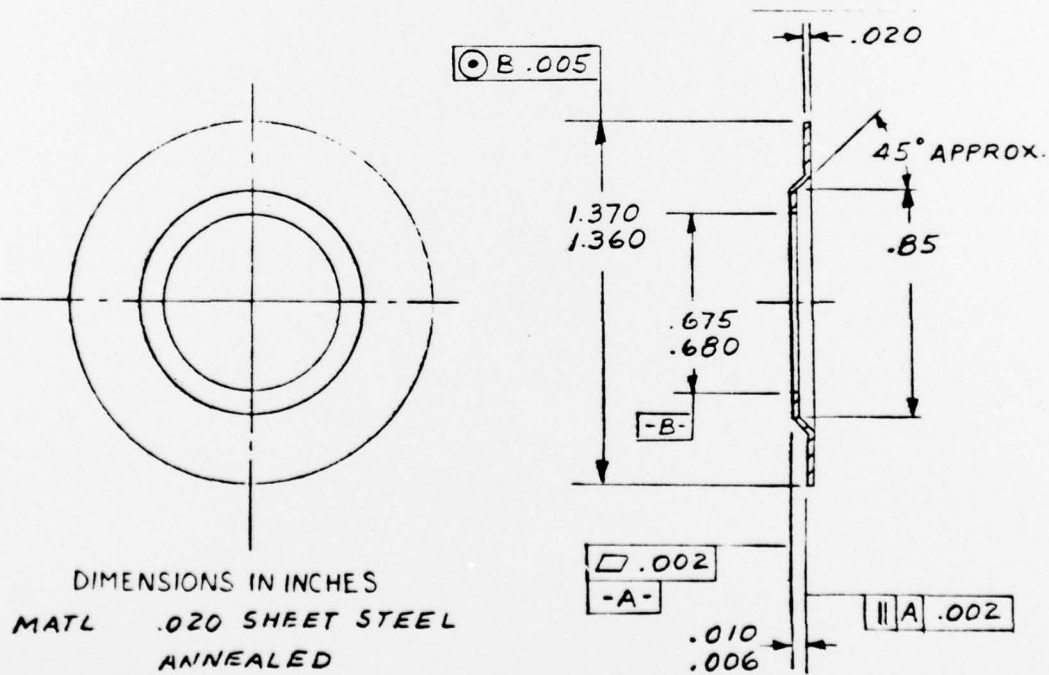

Figure B-2. OH-6A Shield Number S2

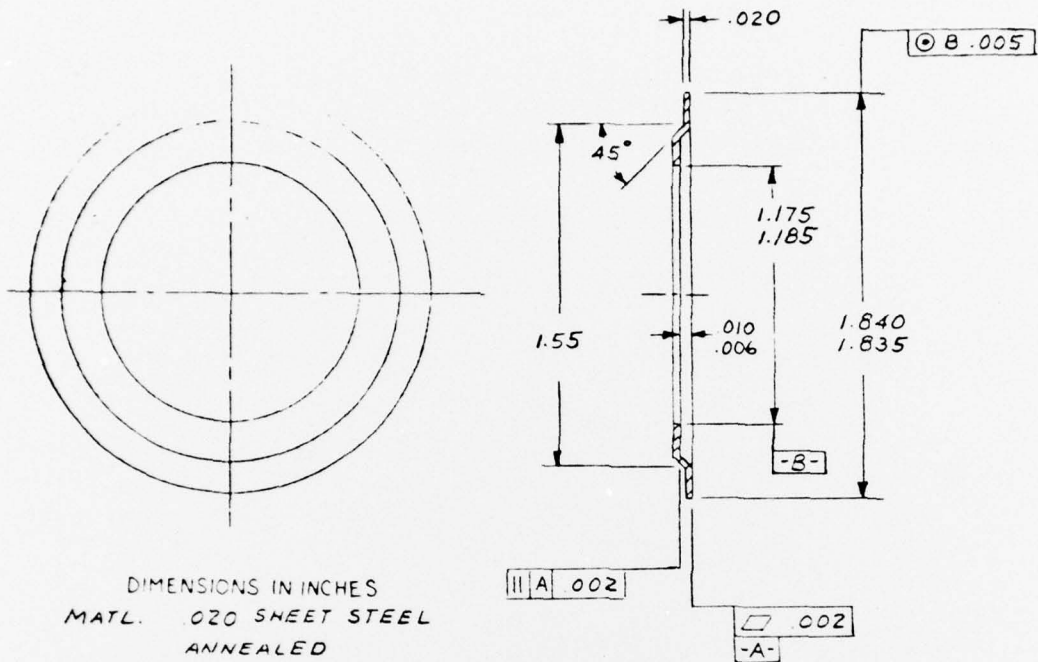

Figure B-3. OH-6A Shield Number S3

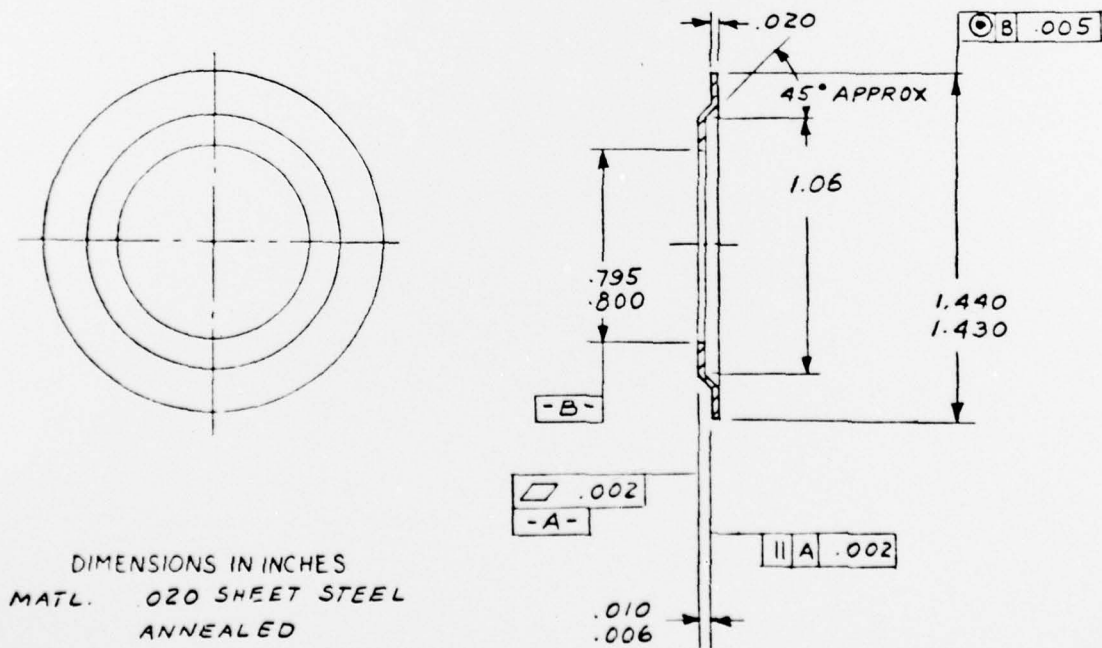

Figure B-4. OH-6A Shield Number S4

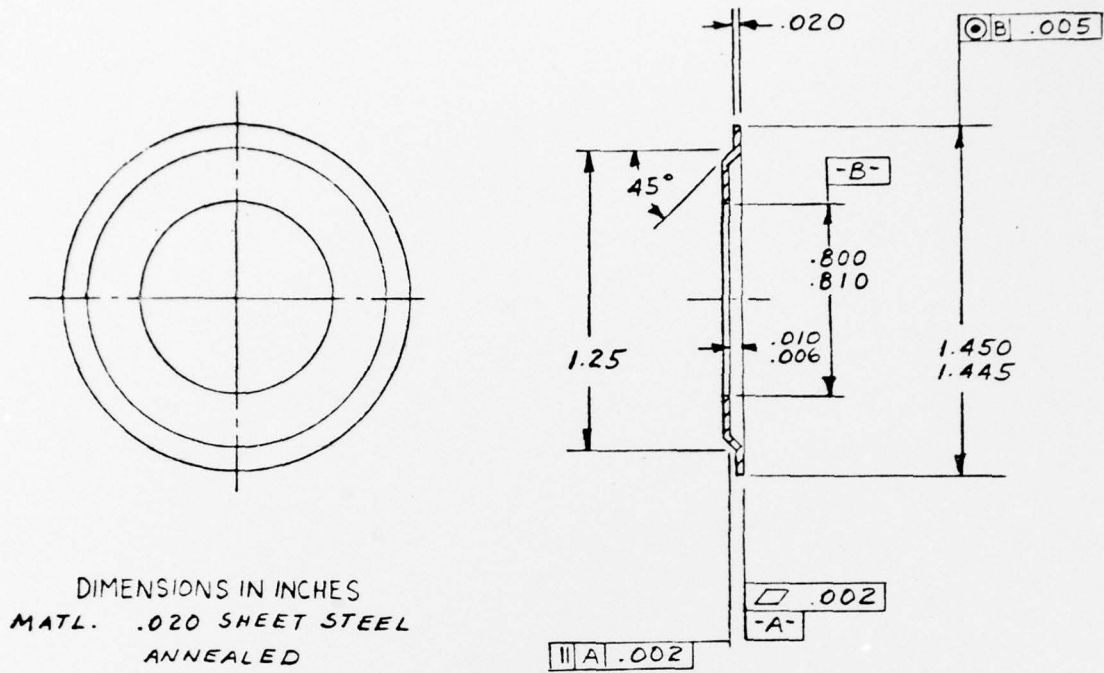

Figure B-5. OH-6A Shield Number S5

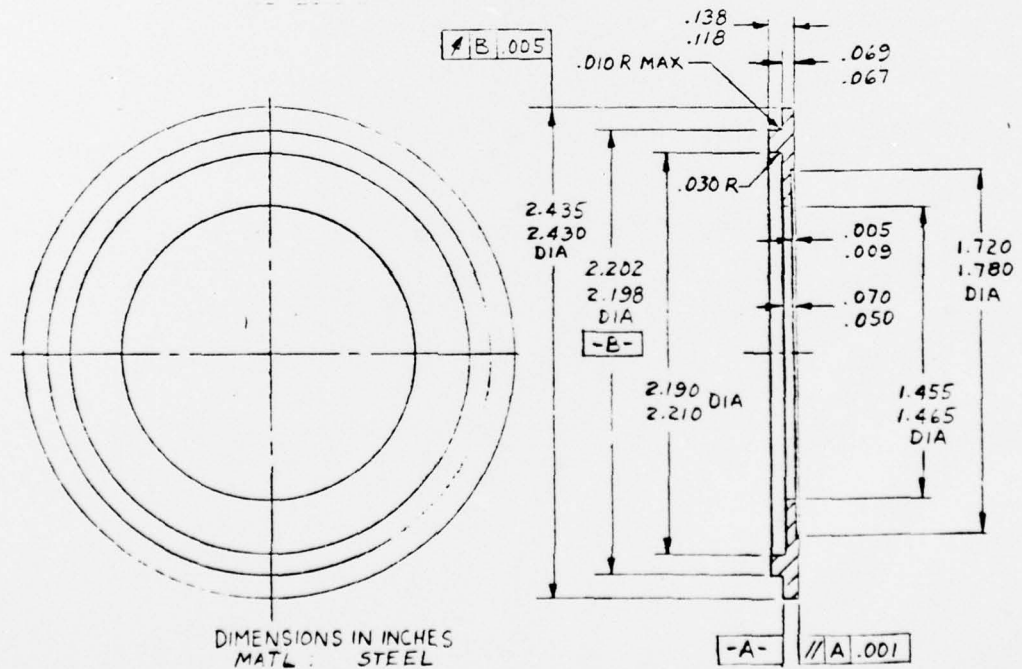

Figure B-6. OH-58 Shield Number S1

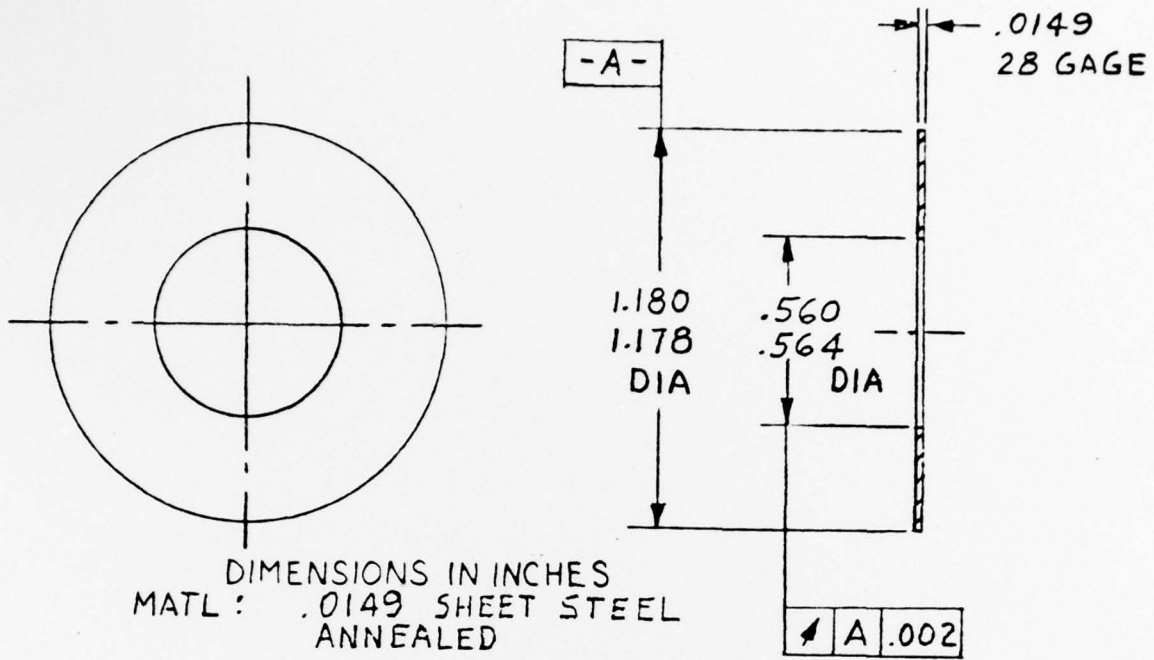

Figure B-7. OH-58 Shield Number S2

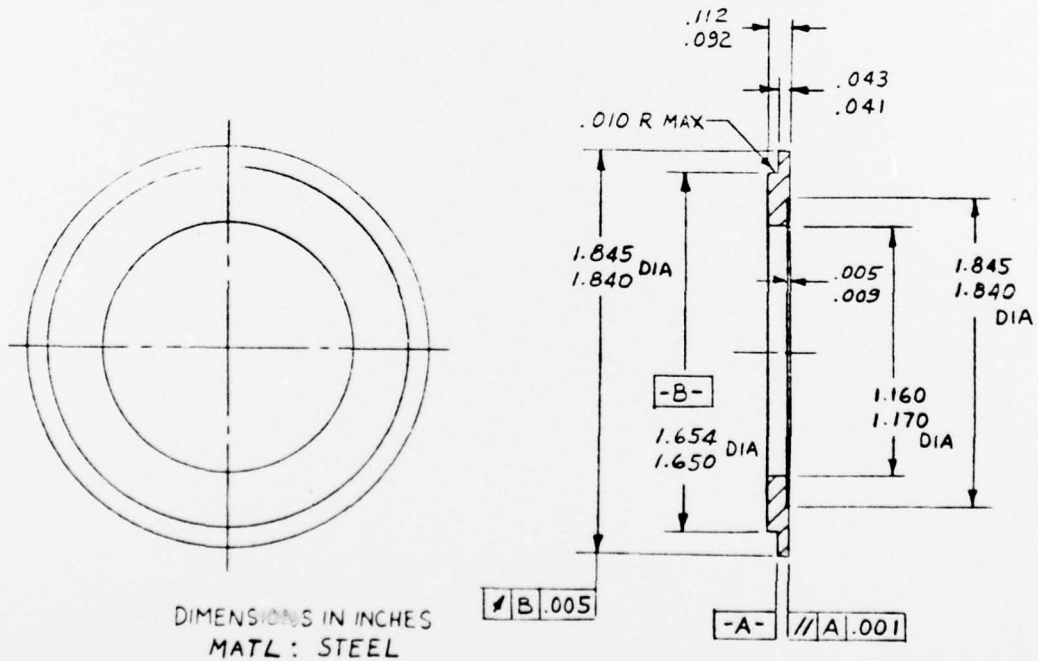
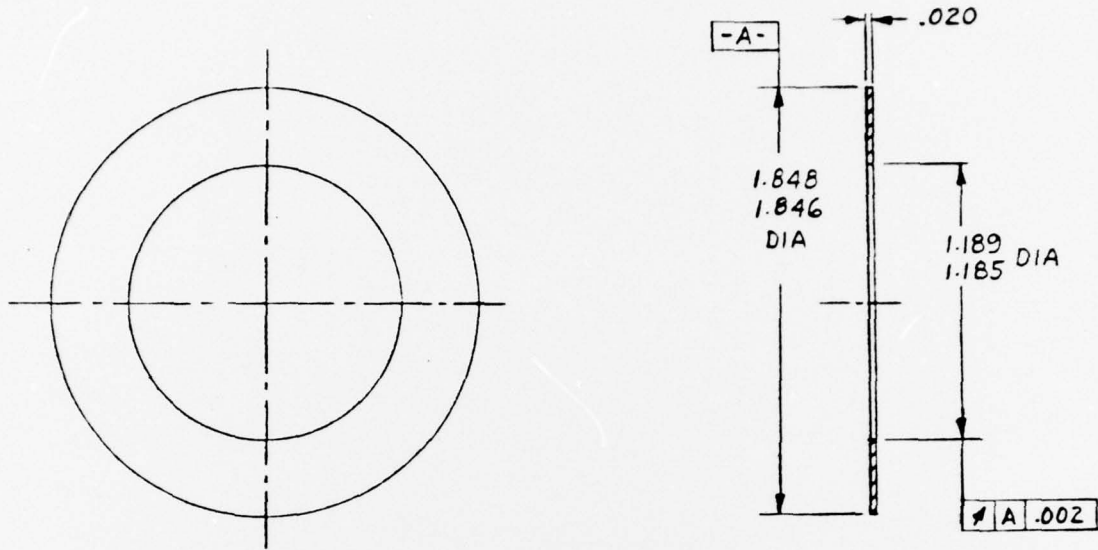
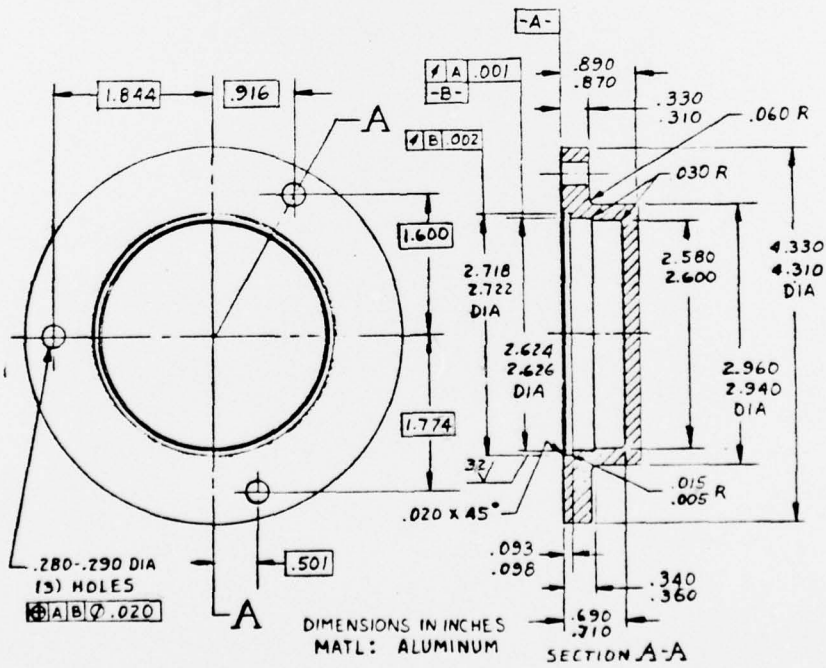

Figure B-8. OH-58 Shield Number S3



DIMENSIONS IN INCHES
 MATL : .020 SHEET STEEL
 ANNEALED

Figure B-9. OH-58 Shield Number S4



DIMENSIONS IN INCHES
 MATL: ALUMINUM
 SECTION A-A

Figure B-10. OH-58 Cover Number C1

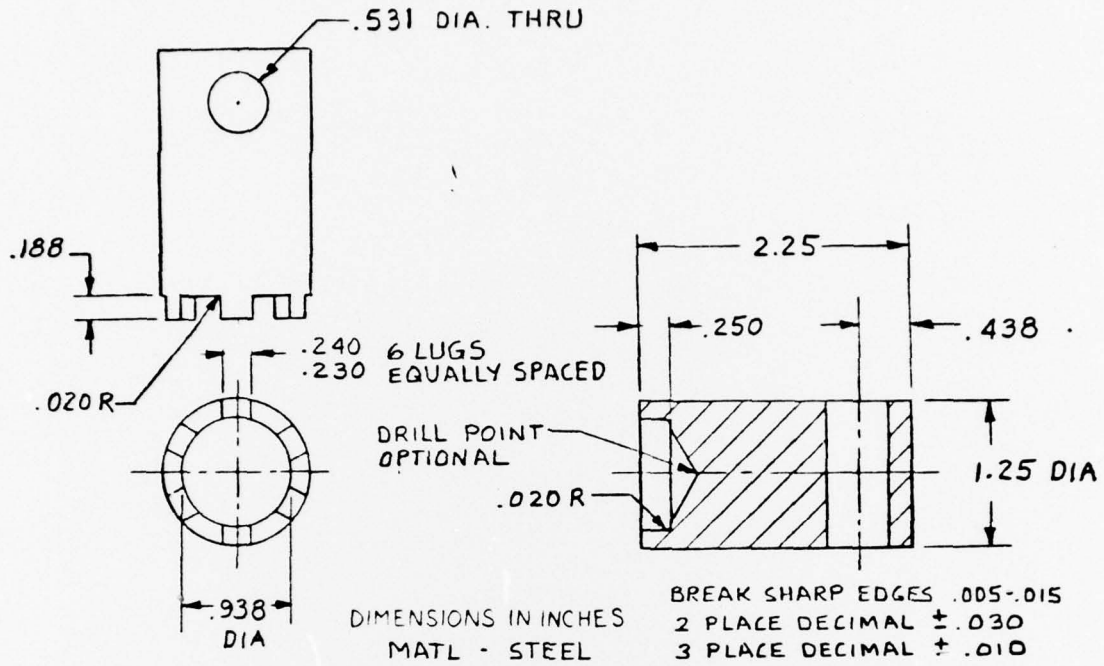

Figure B-11. OH-58 Shop Aid, Barrel Wrench Number W1

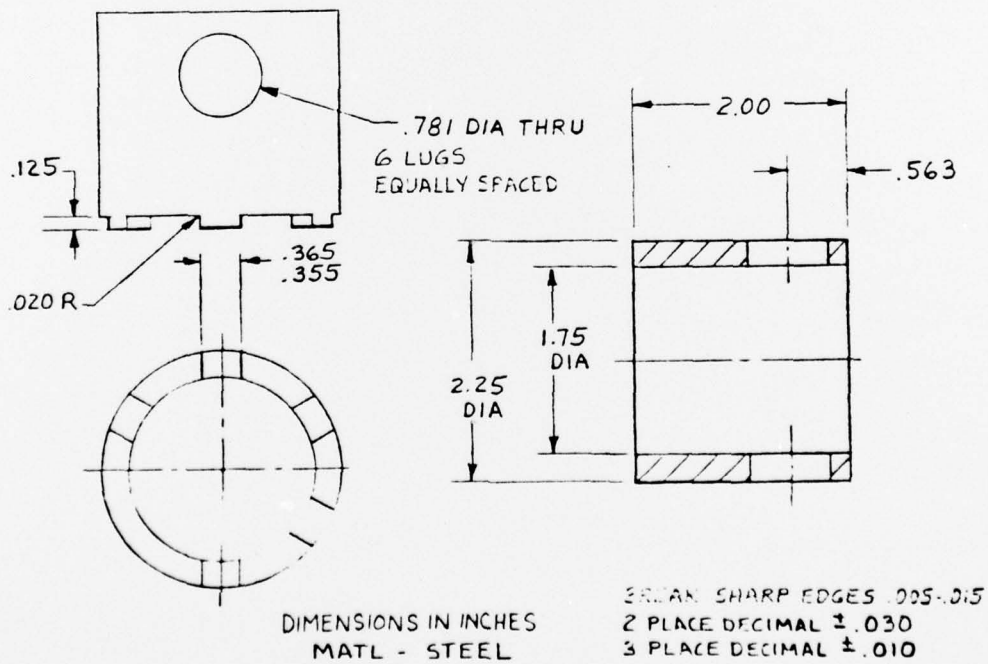

Figure B-12. OH-58 Shop Aid, Barrel Wrench Number W2

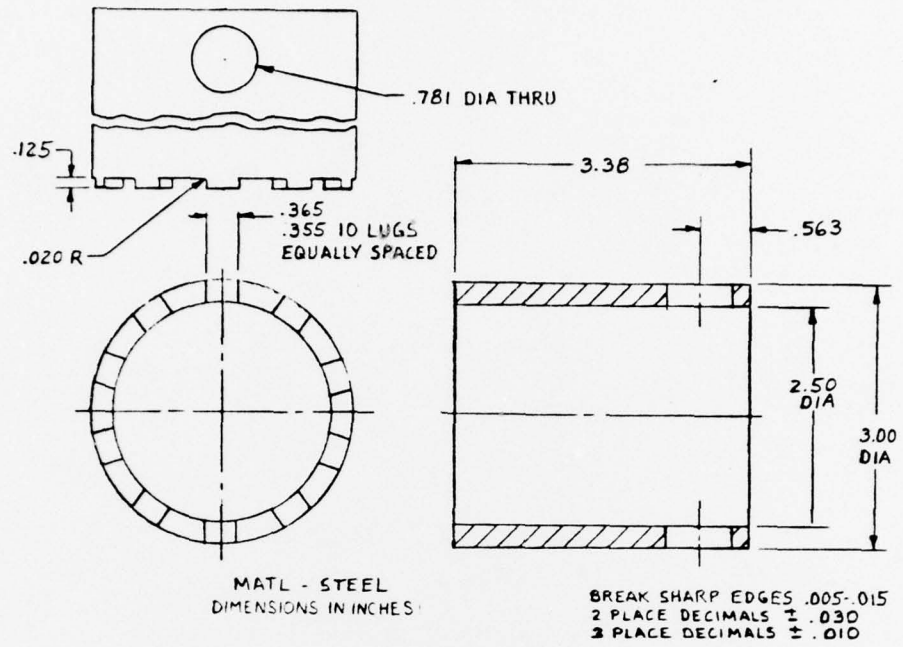

Figure B-13. OH-58 Shop Aid, Barrel Wrench Number W3

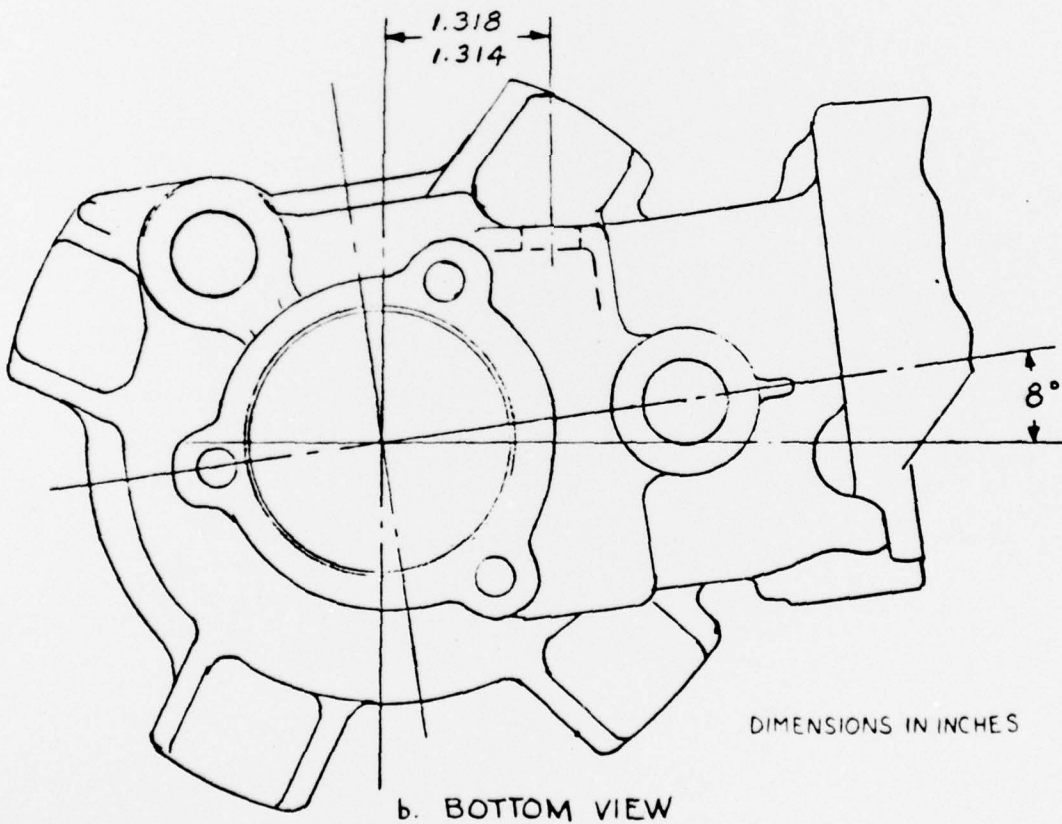
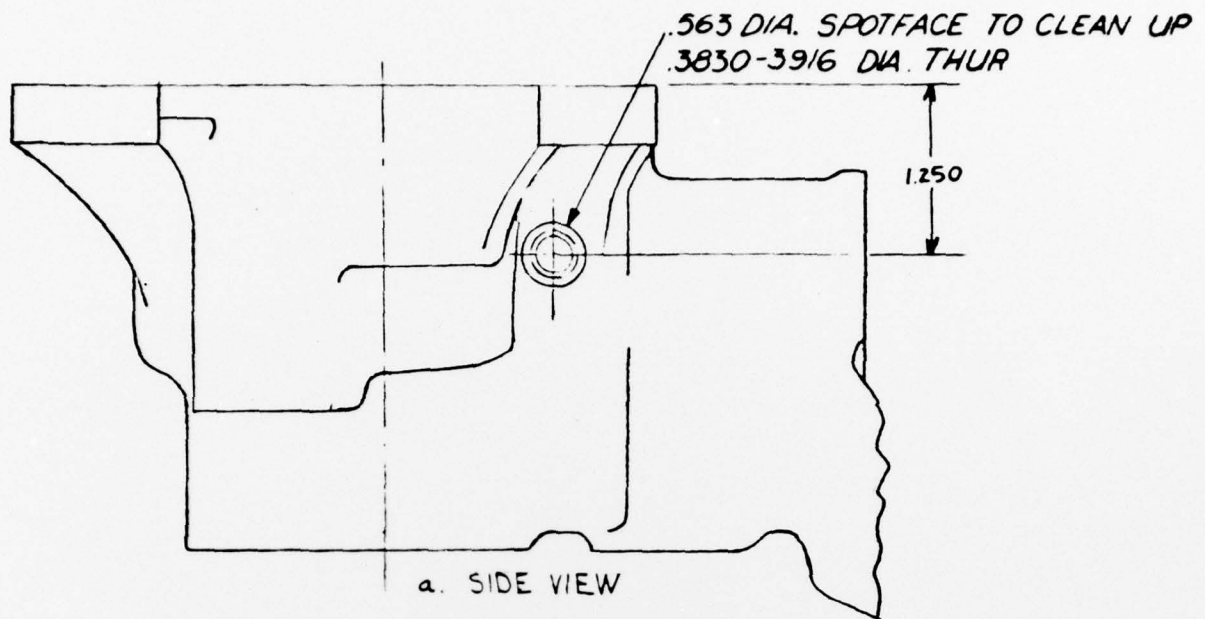

Figure B-14. OH-6A Transmission Housing Modification
Detail for Fail Detection System