

AD A 044679

12 *[Handwritten signature]*

Office of Naval Research  
Contract N00014-69-A-0200-~~1000~~ 1061 ✓  
Project No. NR 053-546

Final Report

NQR and MO Studies of Carboranes

by

Chester T. O'Konski

Department of Chemistry ✓  
University of California  
Berkeley, California 94720

DDDC  
SEP 30 1977  
C  
*[Handwritten initials]*

August, 1977

AD NO. \_\_\_\_\_  
DDC FILE COPY

Reproduction in whole or in part is permitted  
for any purpose of the United States Government

DISTRIBUTION STATEMENT A  
Approved for public release;  
Distribution Unlimited

Unclassified

SECURITY CLASSIFICATION OF THIS PAGE (When Data Entered)

REPORT DOCUMENTATION PAGE		READ INSTRUCTIONS BEFORE COMPLETING FORM
1. REPORT NUMBER	2. GOVT ACCESSION NO.	3. RECIPIENT'S CATALOG NUMBER
4. TITLE (and Subtitle) NQR and MO Studies of Carboranes.	9	5. TYPE OF REPORT & PERIOD COVERED Final rept.
7. AUTHOR(s) Chester T. O'Konski	15	5. PERFORMING ORG. REPORT NUMBER
9. PERFORMING ORGANIZATION NAME AND ADDRESS Department of Chemistry University of California / Berkeley Berkeley, CA 94720		8. CONTRACT OR GRANT NUMBER(s) 1061 N00014-69-A-0200- <del>1061</del>
11. CONTROLLING OFFICE NAME AND ADDRESS Office of Naval Research Chemistry Program (Code 472) Arlington, VA 22217	11	10. PROGRAM ELEMENT, PROJECT, TASK AREA & WORK UNIT NUMBERS NR 053-546
14. MONITORING AGENCY NAME & ADDRESS (if different from Controlling Office) 12 25p.		12. REPORT DATE August 1977
		13. NUMBER OF PAGES 22
		15. SECURITY CLASS. (of this report) Unclassified
		15a. DECLASSIFICATION/DOWNGRADING SCHEDULE
16. DISTRIBUTION STATEMENT (of this Report) Approved for public release; distribution unlimited.		
17. DISTRIBUTION STATEMENT (of the abstract entered in Block 20, if different from Report)		
18. SUPPLEMENTARY NOTES		
19. KEY WORDS (Continue on reverse side if necessary and identify by block number) Nuclear quadrupole resonance (NQR) spectroscopy Pulsed NQR spectrometer Continuous-wave (CW) NQR spectrometer Molecular orbital calculations Electric field gradients		
20. ABSTRACT (Continue on reverse side if necessary and identify by block number) N14 This research consisted of four coordinated types of activity: (1) the design and construction of a pulsed NQR spectrometer; (2) testing it with known <sup>11</sup> B resonances and experimental searches for boron NQR spectra, including some carboranes; (3) searches for carborane <sup>11</sup> B - NQR resonances using a CW - NQR spectrometer; and (4) molecular orbital computations of wave functions and electric field gradients in some small carboranes. 211 Highlights of the four technical reports issued previously are presented.		

Unclassified

SECURITY CLASSIFICATION OF THIS PAGE(When Data Entered)

# 19: Molecular electronic wave functions  
Boron-11 NMR studies  
Small carboranes ( $B_3$  to  $B_5$ )

APPROVED	
DATE	10/10/80
DDG	6/11/80
UNANNOUNCED	<input type="checkbox"/>
JUSTIFICATION	
BY	
DISTRIBUTION/AVAILABILITY NOTES	
TO	
A	

Unclassified

SECURITY CLASSIFICATION OF THIS PAGE(When Data Entered)

# DISCLAIMER NOTICE

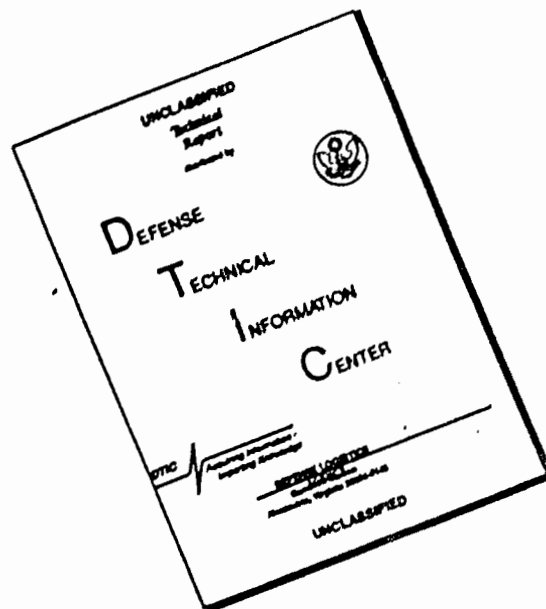

THIS DOCUMENT IS BEST QUALITY AVAILABLE. THE COPY FURNISHED TO DTIC CONTAINED A SIGNIFICANT NUMBER OF PAGES WHICH DO NOT REPRODUCE LEGIBLY.

## ABSTRACT

A summary of the work on the above project is presented. This includes a description of the pulsed NQR instrumentation assembled for this work, as well as highlights from the four Technical Reports issued, and from internal laboratory reports. One technical report is in press and the other three are to be submitted for publication after minor up-dates.

## INTRODUCTION

The work under this project consisted in the main of four coordinated types of activity: (1) the design and construction of a pulsed NQR spectrometer; (2) testing it with known  $^{14}\text{N}$  resonances and experimental searches for boron NQR spectra, including some carboranes; (3) searches for carborane  $^{11}\text{B}$  NQR resonances using over cw NQR spectrometer, and (4) molecular orbital computations of wave functions and electric field gradients in some small carboranes.

The long-range objectives of the work included bringing NQR spectroscopic methods to bear upon the problems of bonding, intermolecular forces and molecular motions in polymers. We also hoped to apply and to evaluate molecular orbital computational methods for the elucidation of the electronic structure of the carboranes. The feasibility of NQR studies of carborane polymers and copolymers was also to be examined.

## PULSED NQR SPECTROMETER

The pulsed NQR spectrometer assembled for these studies is illustrated in Fig. 1. The radio frequency source is a General Radio oscillator operating in the low megahertz region. Its output is gated under the control of an analog pulse programmer and put through to a high power RF amplifier system which drives a conventional impedance matching network  $C_1 - L_1$ . The analog pulse programmer and the RF gate were designed and constructed here by Dr. J. W. Jost.

A conventional back-to-back diode coupling system sends the signals to the tank circuit,  $C_2-L_2$ . The pulsed signals were detected in a Matec receiver equipped with a two-stage diode clamping circuit to limit input power. The output of the receiver was sampled 2800 times per pulse and digitized amplitudes were stored in the ICE-9200 transient recorder. The analog signal is presented on the oscilloscope for visual observations during the experiments, and can be inked on an X-Y plotter for a permanent record.

The digital output for the transient recorder went to an interface we designed and constructed, and then to a PDP 11/10 minicomputer for data processing and storing. The minicomputer was under the control of either a Tektronix cathode ray terminal or a Teletype at the option of the user. Advanced Electronics Design Model 2500 dual drive floppy disc unit was made an integral part of our operating system. Permanent records of numerical data are hard copied on the teletype. In the extended stages of this study, CRT plots were inked on an X-Y recorder by the computer system, using an interface designed, constructed and documented by Mr. George Wiley, a recent senior research student.

This on-line NQR spectrometer system has been used to observe free induction decay (FID) signals and spin-echo signals. The pulse programmer permitted single or double pulse sequences of variable length and spacing. Various computer programs were written for storing and for displaying the transient signals on a cathode ray terminal employed with the PDP 11/10. These include a program which permits the accumulation of many transients and their co-addition to do signal averaging experiments so as to improve the

signal-noise ratio with weak signals. Examples of two FID single pulses observed by Jost are shown in Figs. 2 (hexamethylenetetramine and 3 (urea). Urea and pyrazine echo experiments are shown in Figures 4 and 5. A single pulse FID experiment on pyrazine is shown in Fig. 6. An X-Y plot of a single pulse FID experiment on HMT is shown in Fig. 7, and its Fourier transform is given in Fig. 8. Figures 9, 10, and 11 are composites of FID coadded signals and their Fourier transforms for a sequence of experiments on hexamethylenetetramine with gradually increasing number of pulses: 10, 100, 1000, and they show the marked improvement of S/N ratio achieved with signal averaging, as expected.

#### NQR SPECTRA OF CARBORANES

Observations on several  $^{14}\text{N}$  compounds were made successfully with the pulsed spectrometer, and excellent enhancement of S/N ratio was obtained when we employed signal averaging. The results, already mentioned above, are presented in Figs. 2 to 11.

Numerous attempts were made to find  $^{11}\text{B}$  NQR resonances with the pulsed spectrometer in compounds for which the frequencies had been previously reported from CW observations. We used both FID and spin-echo modes of operation, and employed signal averaging techniques in the latest stages of the work, but these efforts were never successful. This may be due to short spin-spin relaxation times. The NQR signals observed in boron compounds with CW spectrometers are typically around 20 KHz wide, and this indicates a short  $T_2^*$ . There is also the possibility that the electric field gradients in the crystalline compounds are broadly distributed about the

average value because of lattice imperfections. This could reduce sensitivity although it would not necessarily affect the relaxation times. There is a possibility that acoustic modes could be very important in relaxing the nuclear spins; this may be responsible for the broad lines. However, the precise reason for failure to find the boron resonances by pulse techniques is still not clear. Several groups of investigators in various laboratories have also tried unsuccessfully.

Aware of the possibility that we might not be able to find boron NQR spectra with our pulsed instrument, we decided to use our old Pound-Knight-Watkins CW NQR spectrometer and to make searches on available carboranes. Molecular wave functions were computed and field gradients were calculated (see section on Quantum Computations... below). Of the carboranes for which the field gradients were computed, we had available a sample of pentadecaborane. Using the CW spectrometer we promptly succeeded in finding a single-line NQR spectrum at liquid  $N_2$  temperature. It was found at 1.55 MHz which was within 6 percent of the predicted frequency for the gaseous molecule (1.65 MHz). This result will be reported in a brief note to be prepared for publication at some future date.

## QUANTUM COMPUTATIONS OF ELECTRIC FIELD GRADIENTS

A number of ab initio molecular orbital computational methods were considered and examined critically in order to arrive at a feasible approach to the computation of molecular electronic wave functions and of electric field gradients which are needed to interpret NQR data or to predict the frequency range in which one should search for new NQR spectra. In view of our very limited access to computer time on the big computers required for these calculations, we decided to work with the STO-NG program which permits minimal basis set LCAO calculations in which each Slater type orbital is represented as a variable number (N) of Gaussian type basis orbitals (G). This program was tested thoroughly by a series of computations of the molecular wave functions and the electric field gradients of  $\text{NH}_3$  for which the field gradient in the gaseous molecule is known accurately from microwave spectroscopic data. Two approaches to the calculation of the field gradient were used. One of these involved the use of the Slater type orbitals themselves, and the other involved the use of the approximating Gaussians. The results have been presented in ONR Technical Report No. 3 issued in September, 1974. In that study we also used the program GAUSSIAN 70 to generate ab initio wave functions of a higher order of accuracy, and we computed electric field gradients as well. Two different sized basis sets were utilized in these computations: the "4-31" and the more extended "6-31" levels. We learned that the less expensive "4-31" computations with GAUSSIAN 70 were accurate enough to be quite useful for our intended purposes. Then, as a further test of this approach, we calculated

wave functions and field gradients for another nitro-containing molecule of considerable theoretical interest, imidazole. That study has been described in ONR Technical Report No. 2, issued in August, 1974.

Finally, we chose three carboranes of a size small enough so that the computations could be made with GAUSSIAN 70 on our campus computer center CDC 6400 computer. These computations led to predicted values for the electric field gradients and the quadrupole coupling constants of the gaseous molecules. Details are reported in ONR Technical Report No. 4.

## CONCLUSIONS

(1) We constructed a pulsed NQR Spectrometer for the low MHz region and successfully tested it with a number of nitrogen compounds. FID and spin-echo signals were recorded at high S/N in a number of compounds.

(2) However, numerous similar attempts to see known  $^{11}\text{B}$  resonances in a number of compounds were unsuccessful, probably because of short relaxation times ( $T_1$  or  $T_2^*$  or both).

(3) We have used MO theory successfully to predict the quadrupole coupling constant of  $^{11}\text{B}$  in pentadecaborane to within a few percent of the actual frequency.

(4) With a CW Pound-Knight-Watkins type spectrometer we found the NQR resonance in pentadecaborane at liquid  $\text{N}_2$  temperature.

(5) The pulsed NQR apparatus requires a faster response receiver than we had available to pick up FID and spin-echo signals before they decay away. Probably a recovery time about ten times better than the Matec receiver will be needed. Since  $^{11}\text{B}$  NQR line widths are about 20 kHz, the response time should be around 10  $\mu\text{sec}$ . No fast detector was available commercially.

(6) We have designed an automated sweeping pulsed NQR search spectrometer which can be operated by our minicomputer system. This design is presented here, and when implemented, it should permit automatic searches of NQR signals by pulsed methods.

(7) Continuous wave techniques should be pursued to locate more NQR lines in carboranes.

(8) Broad-line  $^{11}\text{B}$  NMR techniques, such as have been used in

the earlier literature, should also be strongly considered for future studies of the quadrupole couplings of carborane monomers and polymers, to obtain data needed for design of pulsed NQR experiments.

(9) The sensitive new double resonance methods should also be considered for  $^{11}\text{B}$  NQR studies.

#### ACKNOWLEDGMENTS

I wish to emphasize Dr. John W. Jost's key contributions to the design and construction of the pulsed NQR spectrometer, including the computer hardware and software developed for this and a companion NIH project on electro-optic studies. Mr. Robert Purtell assisted in the wiring of the computer interface and in tests of the pulsed instrument, as well as running the CW Spectrometer after improving the Zeeman drive unit. Mr. E. Haberkern wrote some of the PDP 11/10 programs. Mr. Bradley Takasuka and Paul Pau participated in later tests of the spectrometer, and attempts to see  $^{11}\text{B}$  resonances. Mr. George Wiley designed and implemented the X-Y plotter interface. Dr. Phil Miller provided a constant source of interest throughout the project and encouragement during the sometimes frustrating phases.

APPENDIX A

ONR TECHNICAL REPORTS SUBMITTED UNDER

CONTRACT NO. N00014-69-A-0200-1061

PROJECT NO. NR-053-546

- No. 1. "Electro-Optic Data Acquisition and Processing", Chapter 15 by J. W. Jost and C. T. O'Konksi, in Part 2 of the Monograph Molecular Electro-optics, Marcel Dekker, Inc. New York, in press.
- No. 2. "Interpretation of Quadrupole Coupling Constants in Imidazole Using Electric Field Gradients from ab initio Wave Functions" by C. T. O'Konksi and J. W. Jost, August, 1974.
- No. 3. "The Calculation of Electric Field Gradients in Ammonia from ab initio Wave Functions", by C. T. O'Konksi and J. W. Jost, September, 1974.
- No. 4. "The Calculation of Electric Field Gradients from ab initio Wave Functions: 1,5-C<sub>2</sub>B<sub>3</sub>H<sub>5</sub>, 1,6-C<sub>2</sub>B<sub>4</sub>H<sub>6</sub> and 1,2-C<sub>2</sub>B<sub>4</sub>H<sub>6</sub>". J. W. Jost and C. T. O'Konksi, October, 1974.

APPENDIX B

INTERNAL LABORATORY REPORTS

"Operation of PDP-11/10, ICE-9200 Interface", John Jost, February 12, 1974.

"On-Line Pulsed NQR Spectrometer", Revised Edition, Robert Purtell, February 12, 1974.

"Description of On-Line System", John Jost and Michael Kwan, December 13, 1974.

"Procedure for Running On-Line NQR Experiments", Robert Purtell, December 14, 1974.

"Procedure for Fortran Programming on our Laboratory Minicomputer", Dennis Reese, March, 1975.

"NQR Studies of Carboranes with a Continuous Wave Spectrometer", Robert Purtell, Revised Edition, March 18, 1975.

"An On-Line Pulsed Nuclear Quadrupole Spectrometer", Bradley Takasuka, June 3, 1975.

"Instruction Manual for PDP 11/10 to X-Y Plotter Interface", George Wiley, June 25, 1976.

"Pulsed NQR Studies with  $N^{14}$ ", Paul Pau, July, 1976.

"Description of the NQR Programming System", Ernest Haberkern, July 1, 1976.

"Fourier Transform of NQR Data on the PDP 11/10", Ernest Haberkern, July 26, 1976.

Figure 1.

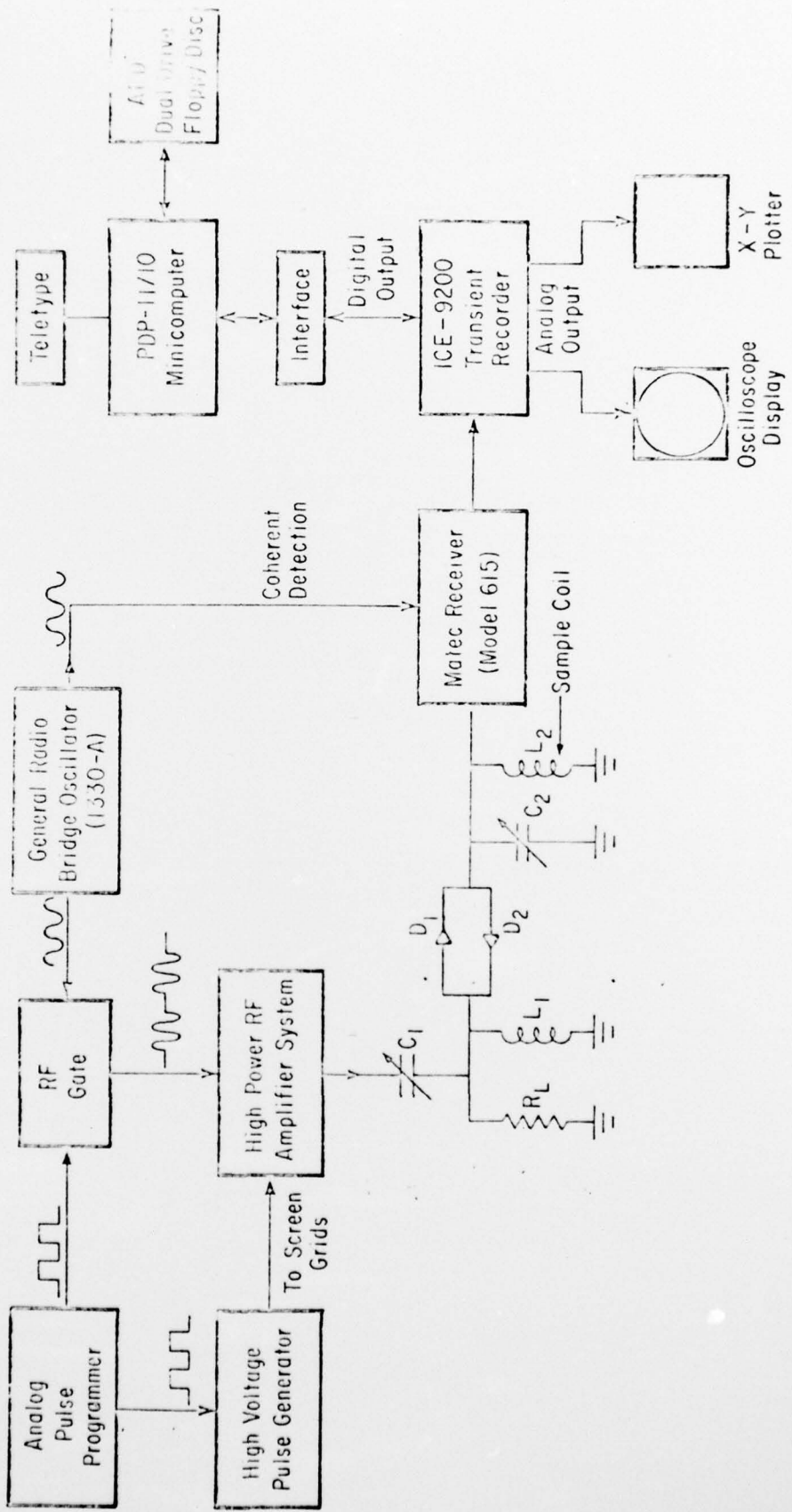

Pulsed NQR Spectrometer (Current System)

FIG. 2 FID OF HMT AT  
77°K, 3404.4 KHZ.

SWEEP: 50  $\mu$ SEC/CM.

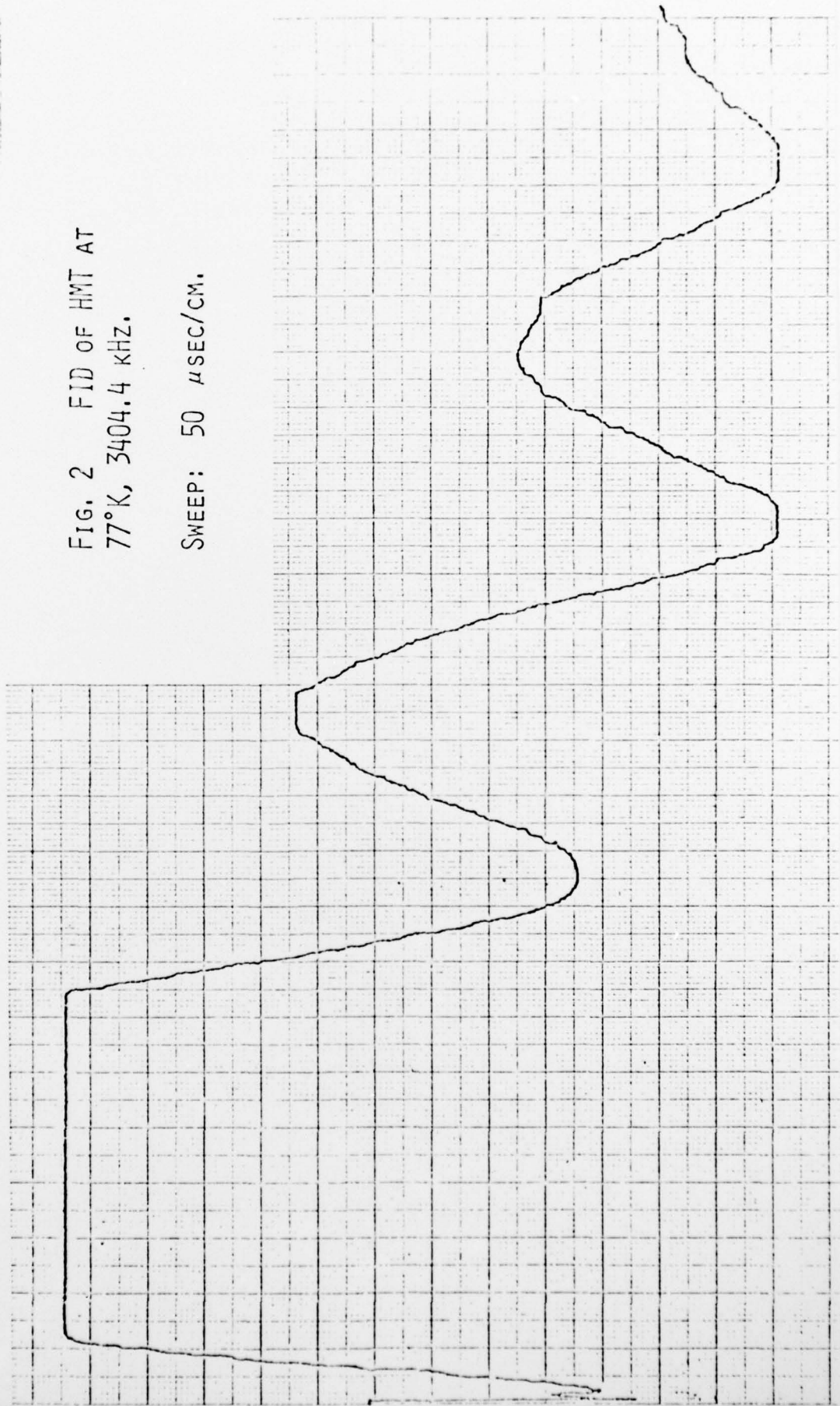

FIG. 3 FID OF UREA AT  
77°K, 2915.2 KHZ.

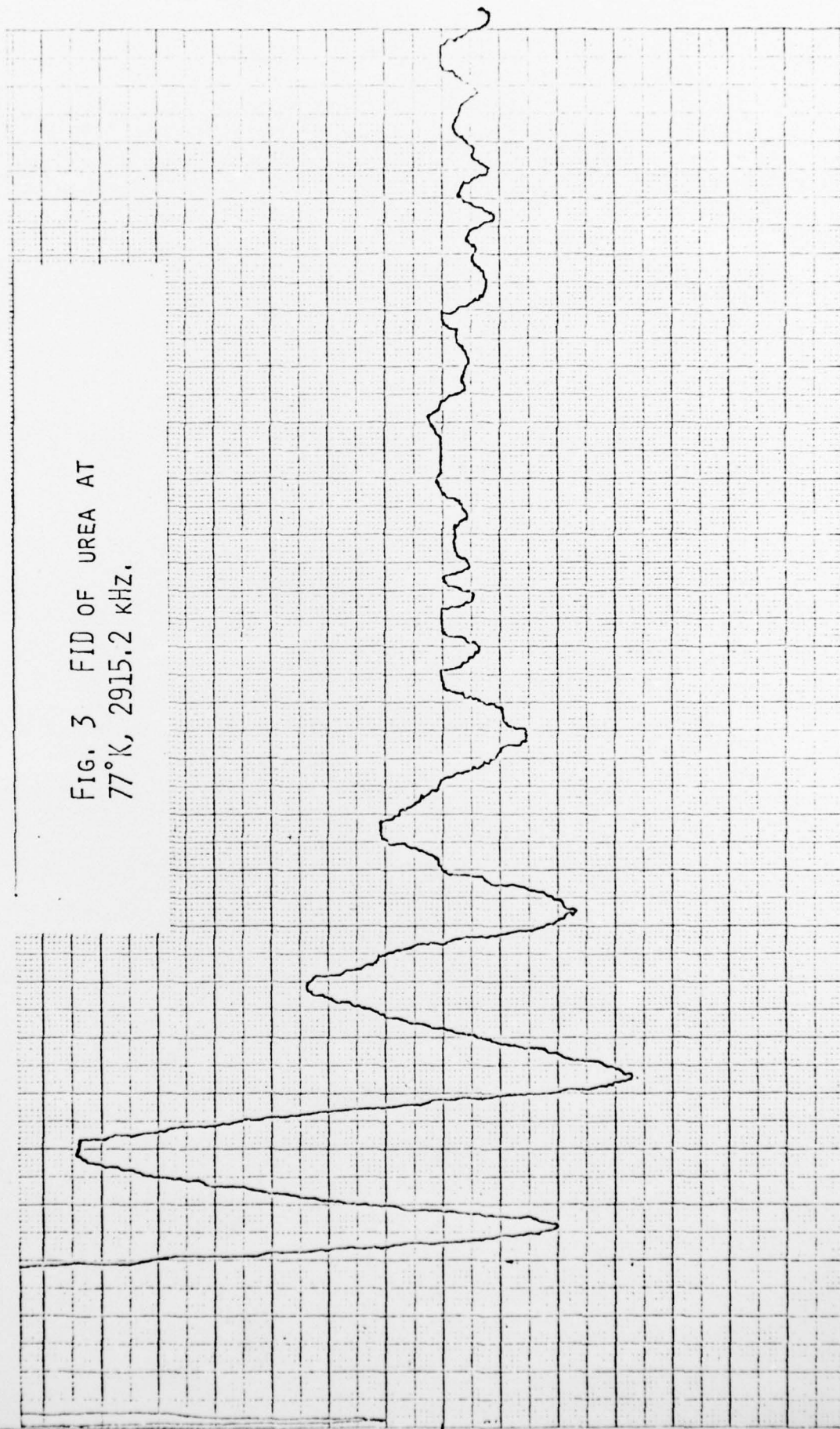

FIG 4. SPIN-ECHO SIGNAL  
OF UREA 77° K.

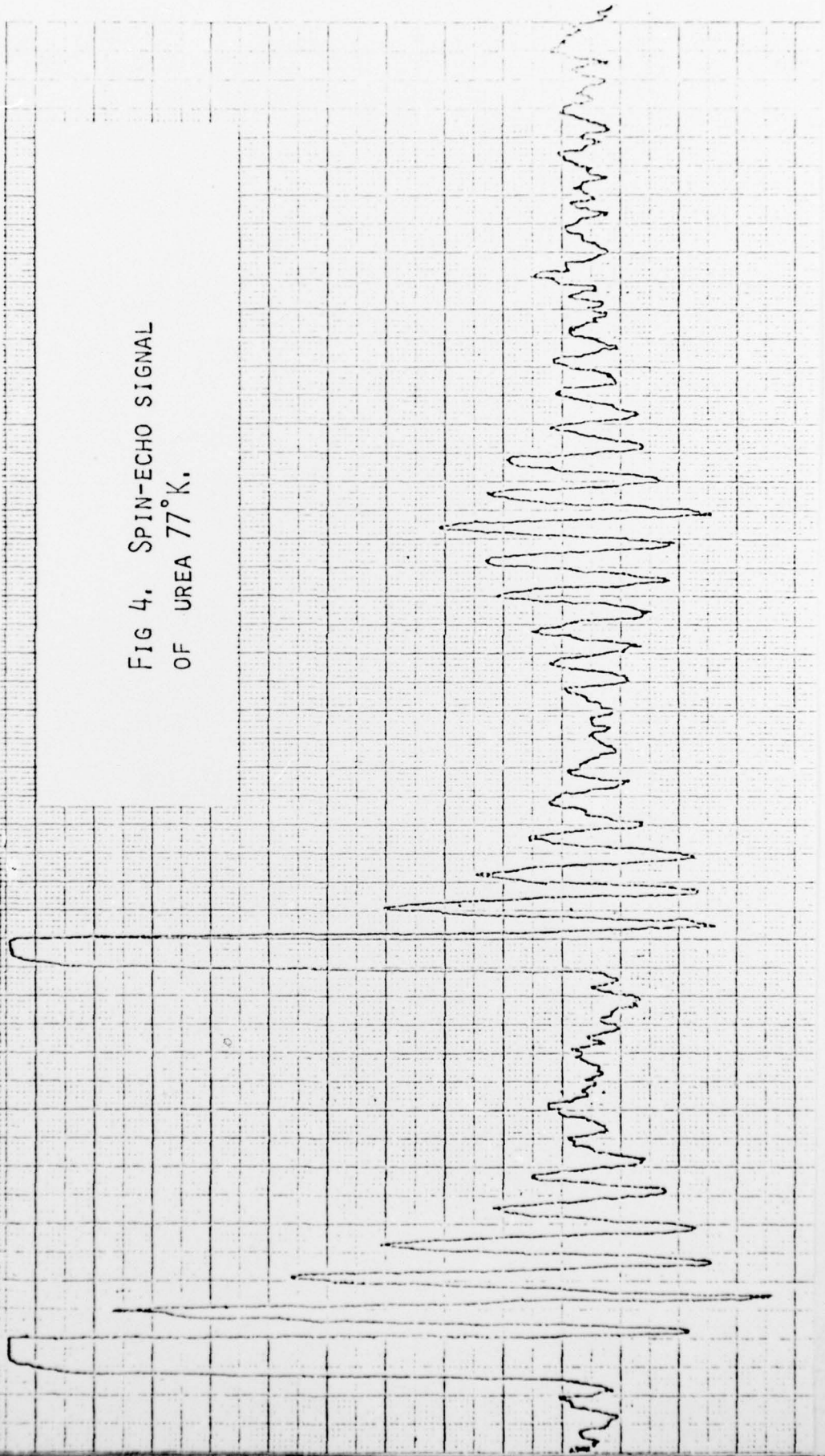

FIG. 5 SPIN-ECHO SIGNAL  
OF PYRAZINE, 77° K. (JWJ AND RP)

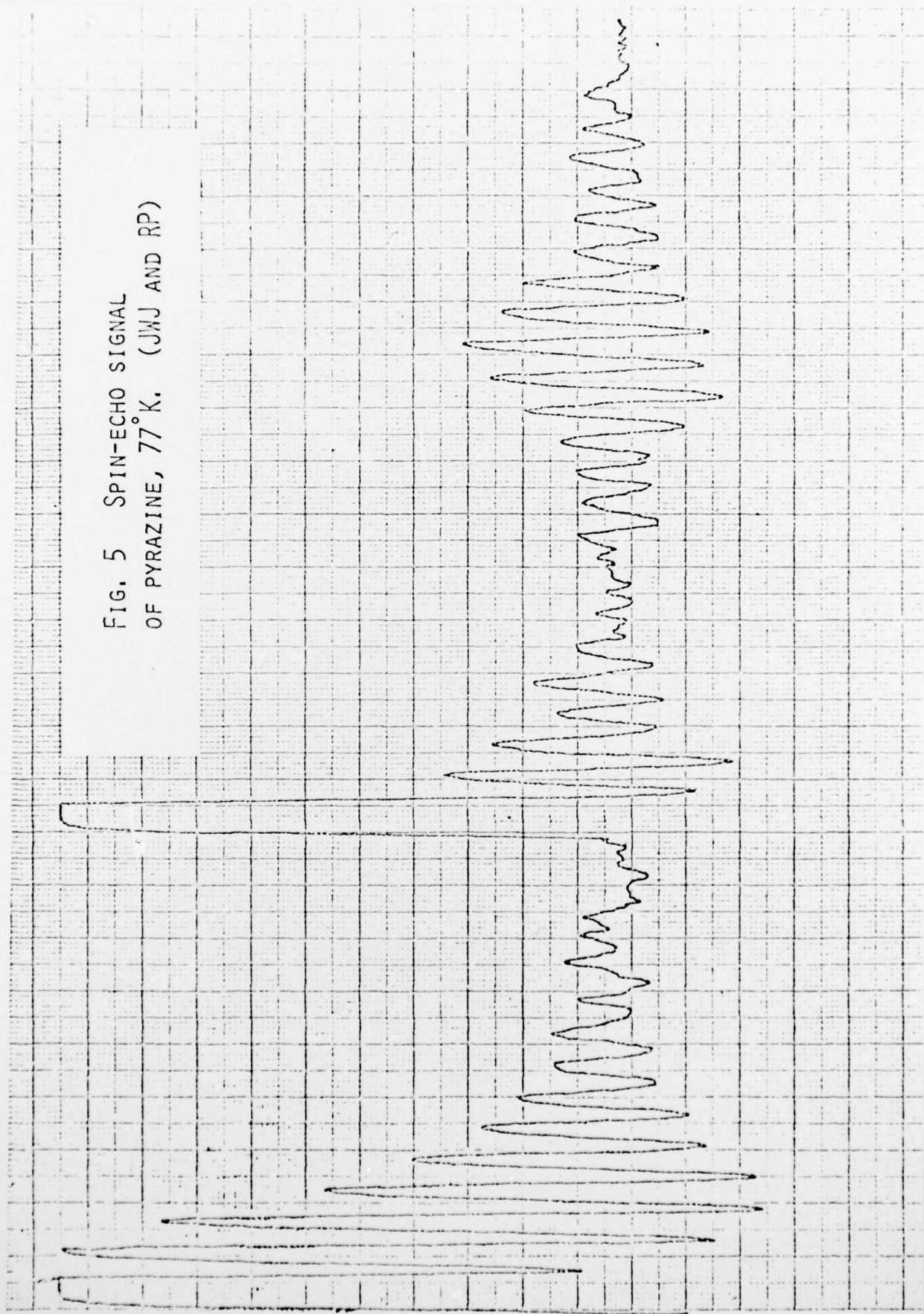

FIG. 6 PYRAZINE  
FID SIGNAL

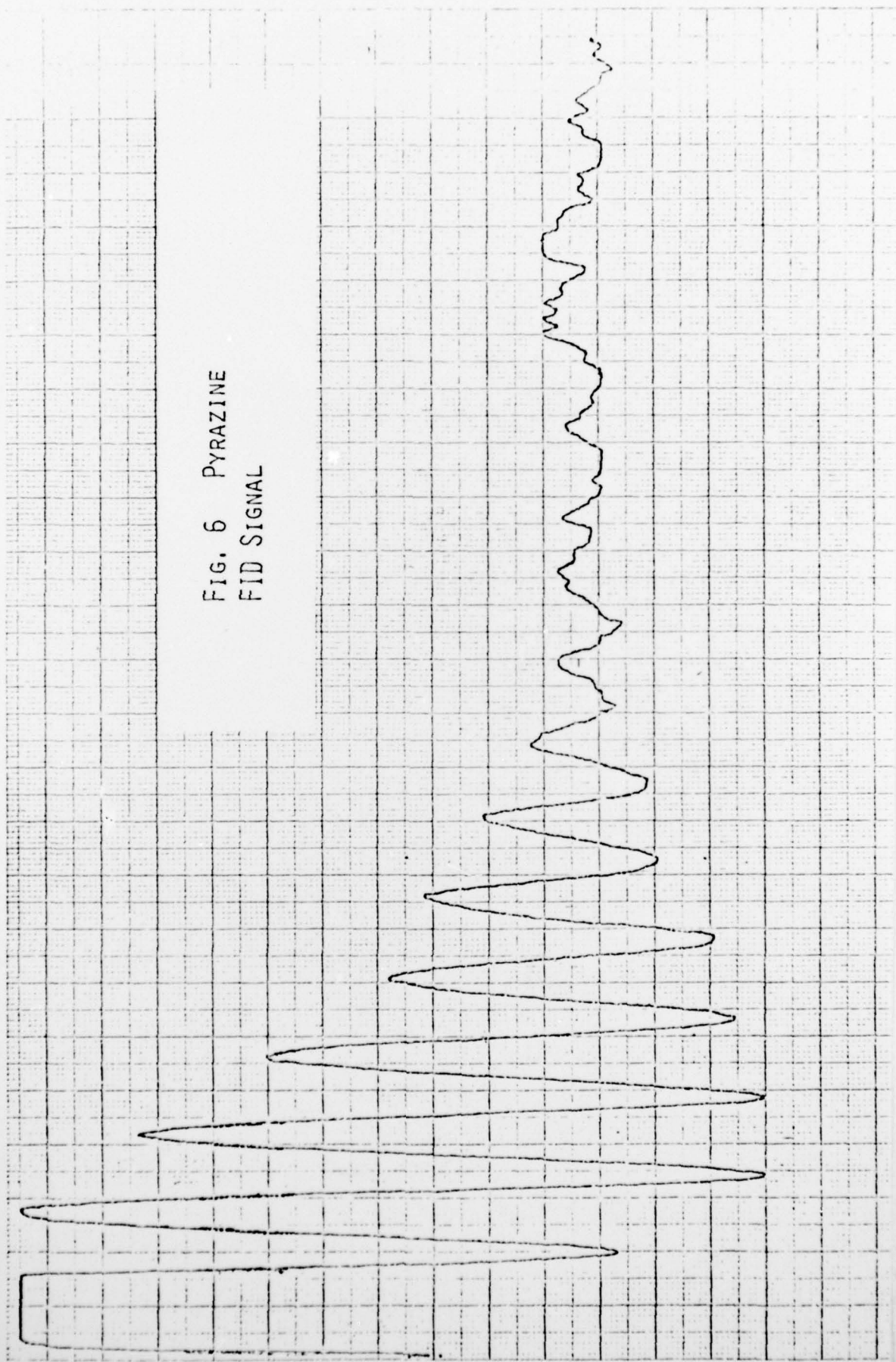

Figure 7. Single Pulse Free Induction  
Decay Signal from Hexamethylene-tetramine  
at 3.302 MHz. Applied RF pulse is off-  
scale to the left. Horizontal sweep is  
4 msec.

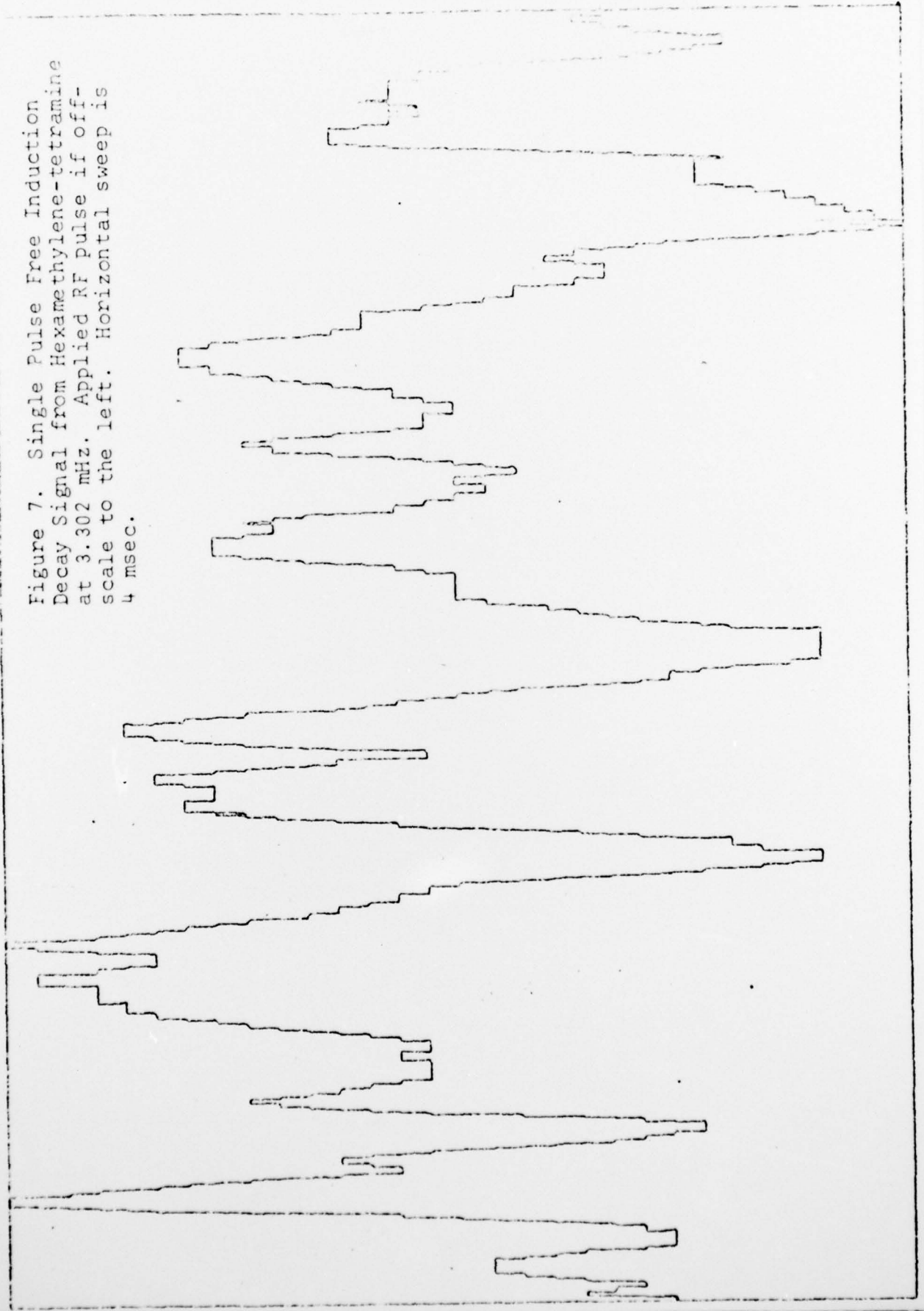
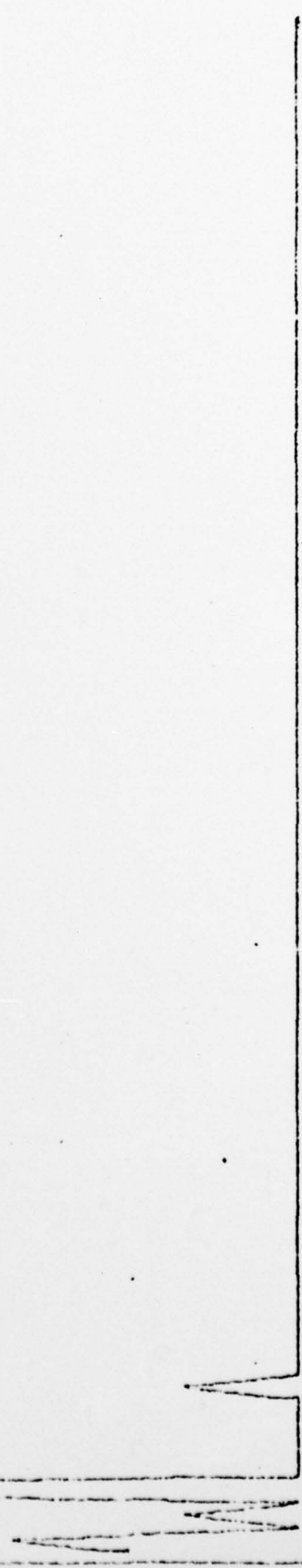

Figure 8. Fourier Transform of FID in  
Fig. 7. The three peaks at the left  
represent random noise. The rightmost  
peak is at 7 kHz. Horizontal range is  
30 kHz.



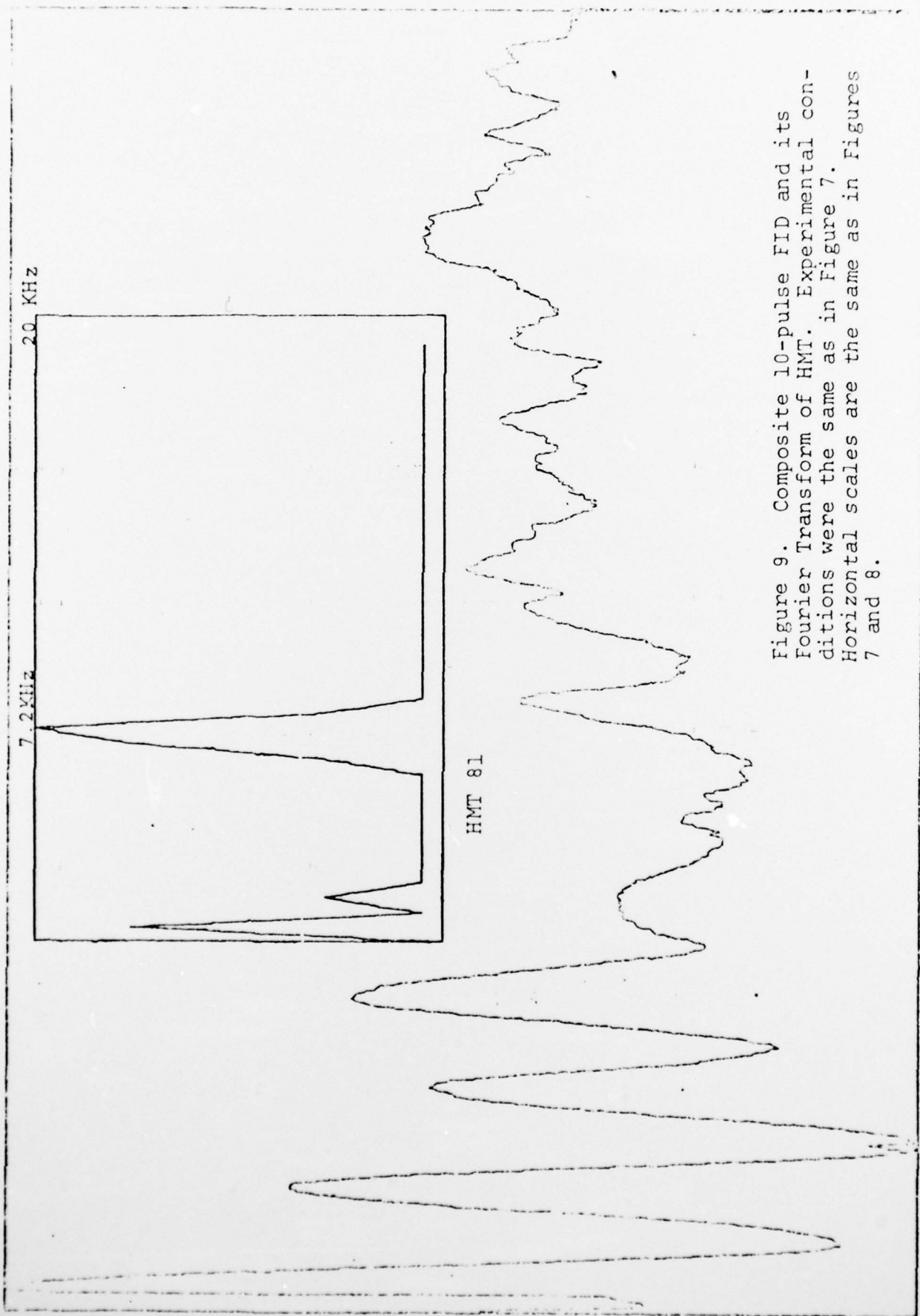

Figure 9. Composite 10-pulse FID and its Fourier Transform of HMT. Experimental conditions were the same as in Figure 7. Horizontal scales are the same as in Figures 7 and 8.

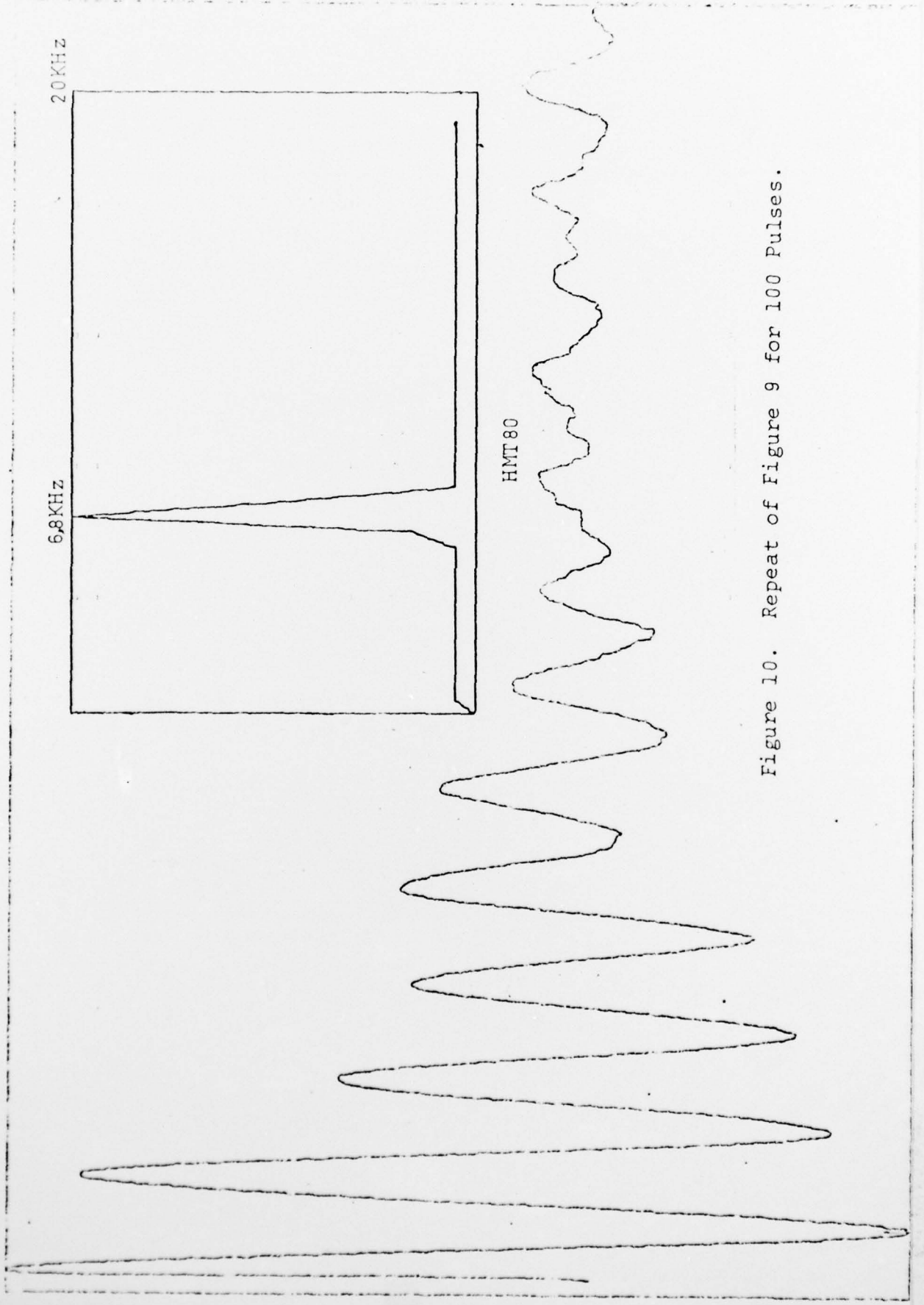

Figure 10. Repeat of Figure 9 for 100 Pulses.

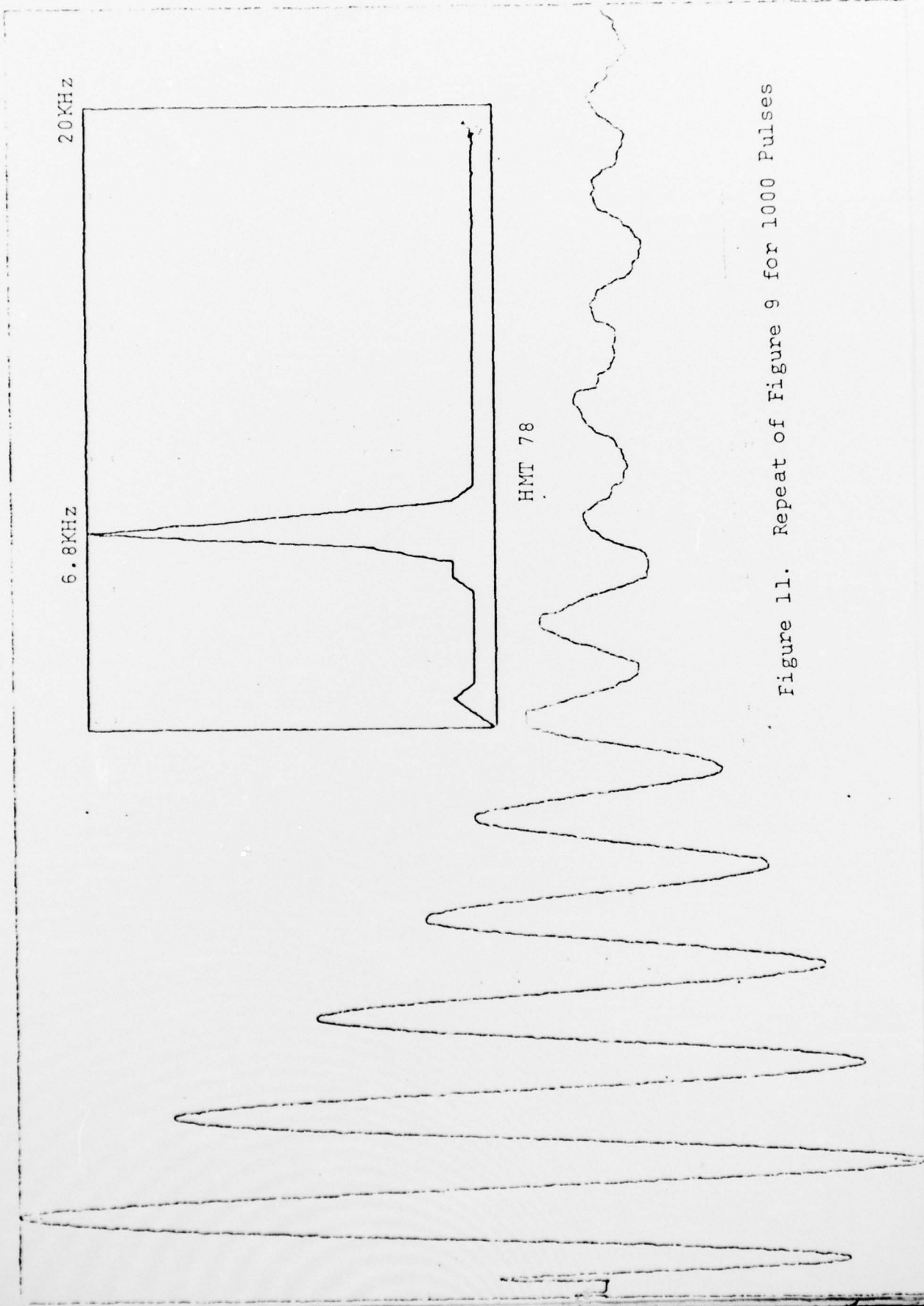

Figure 11. Repeat of Figure 9 for 1000 Pulses