

AD-A044 721

LUNDY TECHNICAL CENTER POMPANO BEACH FL
OPERATION, INSTALLATION AND MAINTENANCE REPORT ON THE MODIFIED --ETC(U)
MAR 75 W WOLNY

N62269-74-C-0659

F/G 17/4

NL

UNCLASSIFIED

D12705(3/75)

1 of 1
ADA044721



END
DATE
FILMED
10-77
DDC

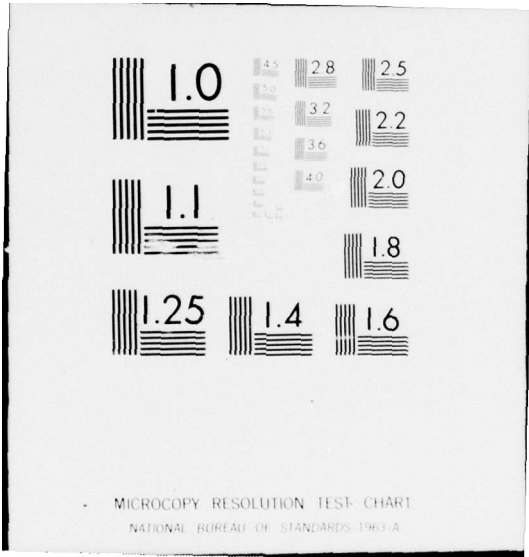

MICROCOPY RESOLUTION TEST CHART
NATIONAL BUREAU OF STANDARDS-1963-A

AD A 044721

OPERATION, INSTALLATION
and
MAINTENANCE REPORT
on the
MODIFIED COUNTERMEASURES
DISPENSER SYSTEM
for the
BQM-34 DRONE AIRCRAFT

2
①

DDC
SEP 23 1977



LUNDY TECHNICAL CENTER

POMPANO BEACH, FLORIDA 33064

LUNDY ELECTRONICS & SYSTEMS, INC.

AD No. _____
DDC FILE COPY

Approved for Public Release;
Distribution Unlimited

UNCLASSIFIED

SECURITY CLASSIFICATION OF THIS PAGE (When Data Entered)

REPORT DOCUMENTATION PAGE		READ INSTRUCTIONS BEFORE COMPLETING FORM
1. REPORT NUMBER 14 D12705 (3/75)	2. GOVT ACCESSION NO.	3. RECIPIENT'S CATALOG NUMBER 7
4. TITLE (and Subtitle) 6 Operation, Installation and Maintenance Report on the Modified Countermeasures Dispenser System for the BQM-34 Drone Aircraft,	5. TYPE OF REPORT & PERIOD COVERED Final <i>rept.</i> 11 Mar 1975	
	6. PERFORMING ORG. REPORT NUMBER	
7. AUTHOR(s) 10 William Wolny	8. CONTRACT OR GRANT NUMBER(s) 15 N62269-74-C-0659 <i>new</i>	
9. PERFORMING ORGANIZATION NAME AND ADDRESS Lundy Technical Center Pompano Beach, Florida 33064 12 18 R.	10. PROGRAM ELEMENT, PROJECT, TASK AREA & WORK UNIT NUMBERS AIRTASK A5355351/2024/ 2535000001	
11. CONTROLLING OFFICE NAME AND ADDRESS Naval Air Development Center Warminster, PA 18974 11 11	12. REPORT DATE March 1975	
	13. NUMBER OF PAGES 16	
14. MONITORING AGENCY NAME & ADDRESS (if different from Controlling Office)	15. SECURITY CLASS. (of this report) Unclassified	
	15a. DECLASSIFICATION/DOWNGRADING SCHEDULE	
16. DISTRIBUTION STATEMENT (of this Report) Approved for Public Release: Distribution Unlimited		
17. DISTRIBUTION STATEMENT (of the abstract entered in Block 20, if different from Report) This technical report is part of the AN/ALE-44 Chaff/Flare Countermeasures Dispensing System Program		
18. SUPPLEMENTARY NOTES		
19. KEY WORDS (Continue on reverse side if necessary and identify by block number) Supersonic Dispense Cycle Payload Capacity Nose Cone Sequencer Dispensing Pod Tail Cone Wing Mount Controller Weight		
20. ABSTRACT (Continue on reverse side if necessary and identify by block number) The objective of this report is to document all pertinent data, methods and procedures to install, operate and maintain the AN/ALE-44 countermeasure dispensing system. The report includes system characteristics, loading and check-out procedures.		

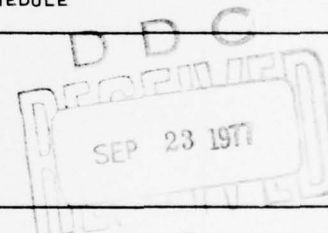

DD FORM 1 JAN 73 1473

EDITION OF 1 NOV 65 IS OBSOLETE
S/N 0102-014-6601

UNCLASSIFIED 406 943
SECURITY CLASSIFICATION OF THIS PAGE (When Data Entered)



Section I INTRODUCTION

1.1 This report contains operations, installation, and maintenance instructions for the Modified Countermeasures Dispensing Pod manufactured by Lundy Technical Center, Pompano Beach, FL 33064 under Part Number 39-0300-001.

1.2 The Modified Countermeasures Dispensing Pod is wing mounted on the BQM-34E/A target drone which dispenses MK47 MOD 0 flares and RR-129 chaff rounds to create false radar targets. The complete dispensing system consists of two wing mounted pods and a single control unit mounted in the drone fuselage.

1.3 The modified pods are distinguishable by the single center mounted sequencer unit which replaces two sequencer units, one mounted outboard of each module in the original configuration. Each pod contains two modules which are held in the pod with four screws and can be easily removed from the pod for loading countermeasures rounds while the pod remains on the drone. No special tools are required for installing or operating the pod set.

1.4 Each dispenser module holds 16 countermeasures rounds (32 rounds in each pod). Countermeasure rounds are dispensed by a remotely commanded dispense signal, in pre-programmed quantities of either 1, 2, 4, 8, or continuous rounds per burst, at the rate of one burst every 1/2, 1, 2 or 4 per second, depending on controller switch settings. The countermeasures payload is dispensed pyrotechnically by an impulse cartridge (squibs) contained within each countermeasures round.

ACCESSION NO.	
NTIS	1/17/75 Section <input checked="" type="checkbox"/>
DDC	2/1/75 Section <input type="checkbox"/>
UNANNOUNCED	<input type="checkbox"/>
INTELLIGENCE	
BY	DISTRIBUTION/AVAILABILITY CODES
TO	SPECIAL
A	



Section II DESCRIPTION

2.1 The Countermeasure Dispensing system has two major components, the controller and the pod assembly. The pod assembly (Figure 1) is further broken down into identical nose and tail cones, two payload modules, a sequencer unit and an inseparable pod assembly.

2.1.1 Controller Assembly. The controller assembly (see Figure 2) is a sealed unit, measuring approximately 7-1/2 in. wide x 2 in. high x 5-3/4 in. deep. It is located in the equipment bay section of the drone fuselage. The controller receives command signals on a single multiplexed channel, generates pre-programmed firing pulses, and provides preflight switch selection for various dispensing combinations between dispenser modules within a single pod and between pods in a dual pod installation.

2.1.2 Payload Module Assembly. The payload module assembly (see Figure 1) consists of a module, which accommodates 16 countermeasures rounds, and a reusable firing plate.

2.1.3 Sequencer Unit. The sequencer unit (see Figure 1) is located within the center section of each pod. It provides the control interface between the internally located controller and the countermeasures squib firing circuits. The sequencer receives dispense pulse signals from the controller and distributes the signals to the squibs causing dispensing of preselected chaff and/or flare rounds in alternate fore and aft sequence.

2.1.4 Inseparable Pod Assembly. The inseparable pod assembly is a rigid aluminum housing which forms the center section of the pod assembly. All other dispenser components are mounted on the inseparable pod assembly.

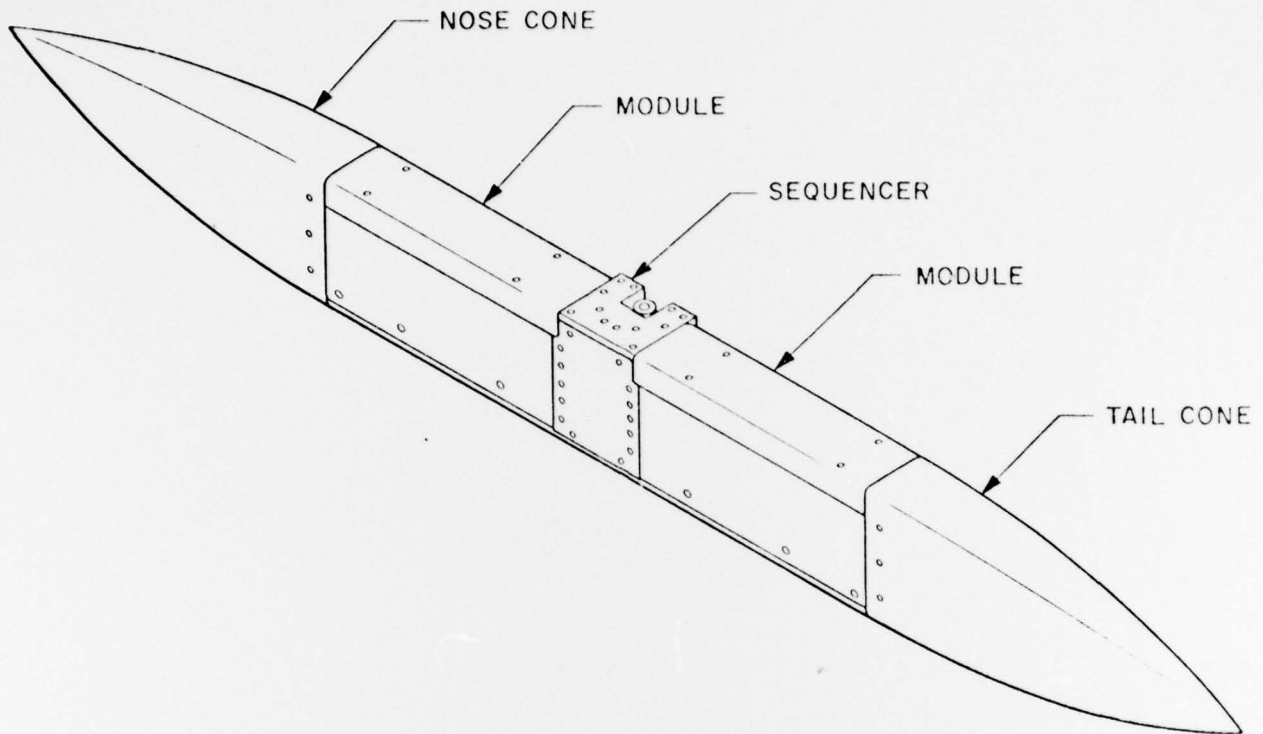

Figure 1 - COUNTERMEASURES DISPENSING POD ASSEMBLY

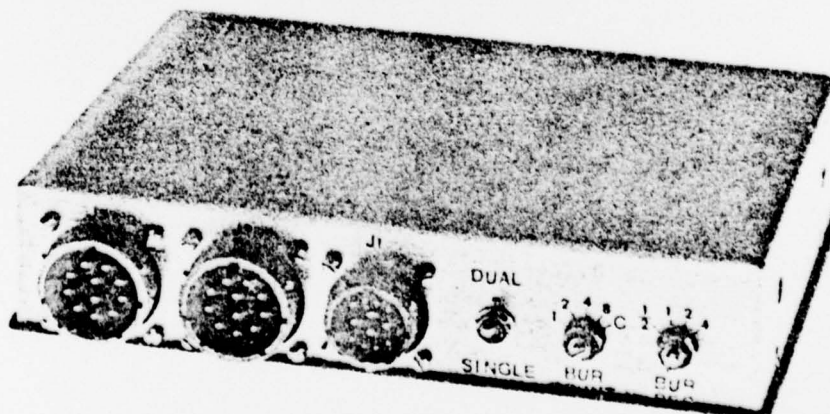

Figure 2 - CONTROLLER ASSEMBLY



2.1.5 Nose and Tail Cones. The nose and tail cones are identical components. They are fabricated using glass reinforced epoxy resin and are suitably shaped, aerodynamically, for supersonic flight.

2.2 Leading Particulars

2.2.1 The major physical and functional characteristics of the Countermeasures Dispensing Pod are summarized in Table 2-1.

TABLE 2-1 System Characteristics

Voltage	28VDC
Environmental Limits: Altitude Speed	60,000 Ft. MACH 1.6 (Maximum)
Life	10 to 12 flights (flight duration 1 Hr. Avg.)
Payload Capacity (each dispensing pod)	32 rounds of chaff and/or flares (physically conforming to RR-129 and/or MK47 MOD 0, respectively)
Dispense Cycle: Dispense Capability (Units/Burst) Dispense Rate (Units/Sec)	1, 2, 4, 8 units or continuous per pulse, as preprogrammed. 1/2, 1, 2 or 4 bursts per second, as preprogrammed
Dimensions: Length Width Height	81.25 in. (maximum) 4.25 in. 7.12 in.
Weight: Dispensing Pod (unloaded) One unit type RR-129 with squib One unit type MK47, MOD 0 with squib	37.00 lbs. (maximum) 0.404 lbs. (nominal) 0.463 lbs. (nominal)

2.3 Support Equipment. A Phillips screwdriver is used to secure the payload modules in the pod and a 1/4 inch Hex wrench is necessary to remove the breech plate from the payload module.



Section III SYSTEM OPERATION

3.1 Controller. The operating controls, located on the controller, are accessible when the equipment bay cover is open. These controls are:

MODE SELECT	-	SINGLE, DUAL
BURST COUNT	-	1, 2, 4, 8, C*
BURST/SECOND	-	1/2, 1, 2, 4

*C - Continuous Dispense

The mode select establishes the number of rounds simultaneously dispensed during a burst (i.e., 1 or 2 units). When in the SINGLE mode, a dispense pulse is routed to one pod. The next dispense pulse is routed to the other pod. This alternating sequence continues with each dispense command until all stores are expended. When in the DUAL mode, the dispense pulse is routed to both pods simultaneously. In either mode the sequence of dispense pulses continues at the burst per second setting until the burst count is satisfied. When the count is satisfied the program sequence stops and must be re-initiated by dispense command. This firing sequence results in a constant pod center of gravity regardless of the number of expendables deployed.

The system power is provided by the drone through controller receptacle J1 pins J, K, L and M with ground return via Pin C. The aircraft command and control signals interface the controller through J1. To ready the system for operation, the arm relay is energized through Pins A & B.

A dispense start command through Pin D starts the dispensing sequence. The system responds and provides a sequence of dispense pulses and squib firing signals at the pod according to the pre-set program.



The dispensing sequence can be stopped at any time by a dispense stop command signal which is routed through Pin F. If the burst count is in the "C" (continuous) position, the sequence can only be terminated by the stop command.

To reset the system, a drone source reset command is provided through Pin G. After the pod safety pins are in place on the command from the drone, the controller provides a 4 pps train of drive pulses to the left pod until it reaches the reset position, then transfers to the right pod to complete its reset function. When each pod is reset a green lamp located in the center section of each pod will flash on and off until the reset command is removed. A reset signal is also provided through J1 pin H to the aircraft/test console for a third reset indication capability.

3.2 Module Loading. A payload module should normally be laid on its side to avoid damage to the safety shorting handle (Figure 3). The breech plate is removed by removing the four 1/4-28 breech plate bolts. Then, using a center hand grip (placing hands on top and bottom of module) and a slight side-to-side wiggle remove the module top. The top can also be removed using an end grip with hands placed on sides of module and pushing upward on breech plates with thumbs until it is free (Figure 4). (Care should be taken not to damage the wire harness when separating the breech plate from the module.) Next, countermeasure rounds are inserted into the module tubes and squibs are inserted into the wire harness connectors. The breech plate is then re-attached (by placing breech plate on module and bolting them together). Care should be taken to assure that the wire harness is positioned properly in the guide, shown in Figure 5, otherwise the harness may interfere with proper seating of the module in the pod. During loading and downloading of chaff and flare countermeasures, rounds will be handled in accordance with local ordinance procedures (References NAVWEPS 16-1-5.29).



3.3 Module Installation. During ground handling the safety pin must be inserted in the pod center section and the safety shorting connectors must be inserted in the modules (see Figure 6). Insert the modules by positioning them in the pod and then pushing on the screw fastener to engage at least one thread. The screw is then fully engaged using the Phillips screwdriver. The nose and tail cones do not have to be removed for module installation or removal.

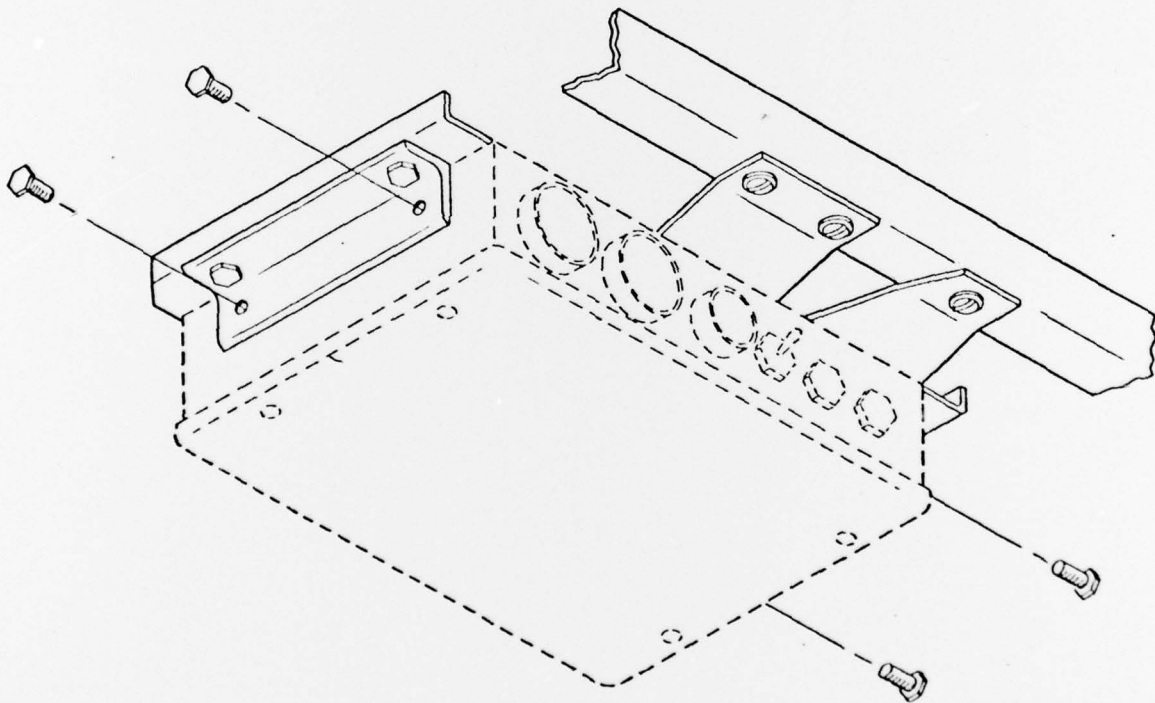

Figure 7 - CONTROLLER MOUNTING BRACKET ASSEMBLY

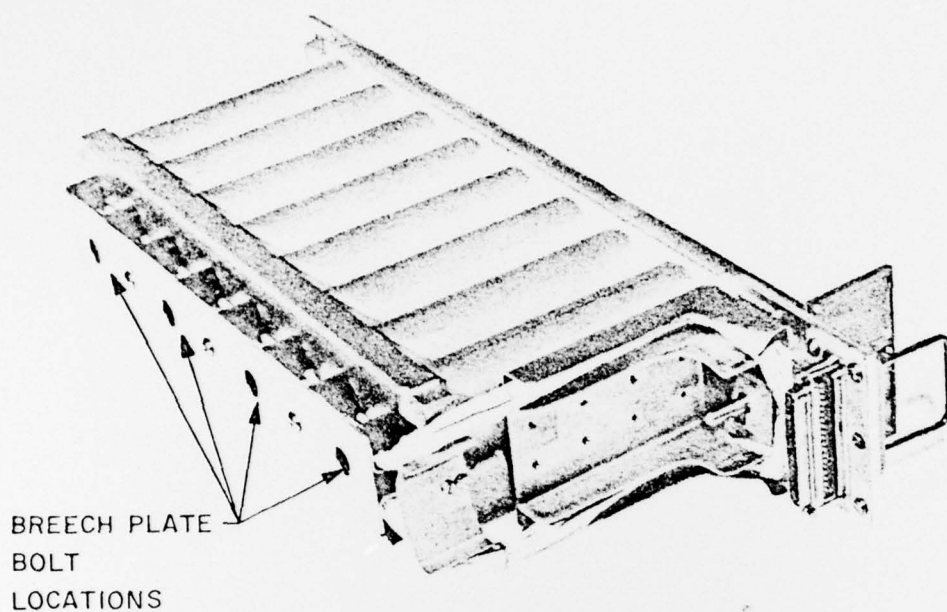

Figure 3 - MODULE (REMOVED FROM POD)

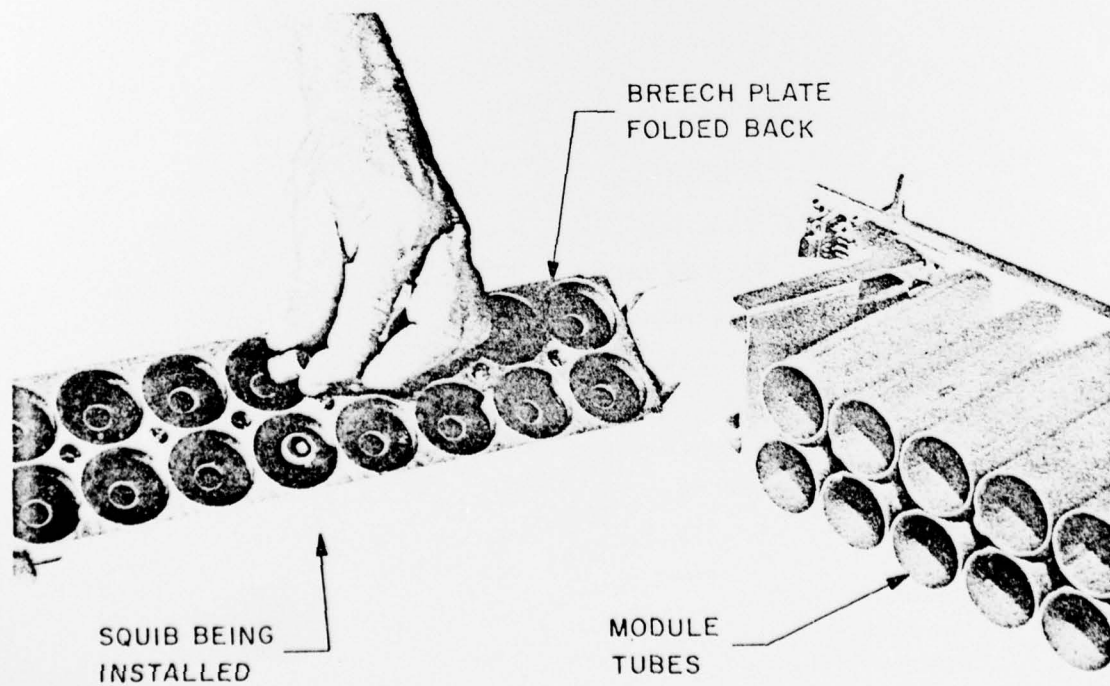

Figure 4 - MODULE (BREECH PLATE REMOVED)

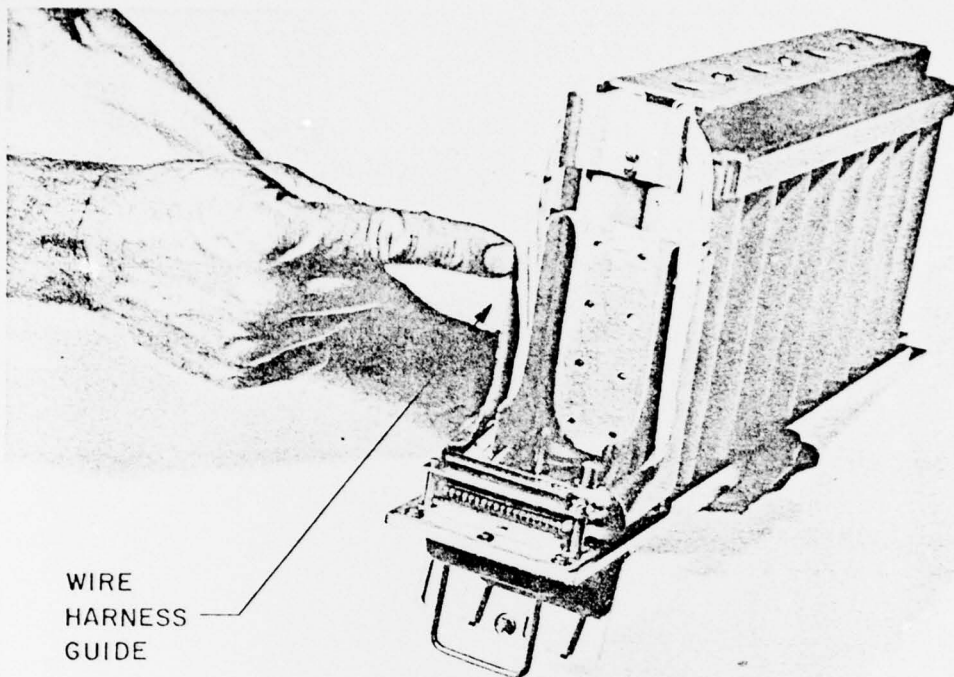

Figure 5 - WIRE HARNESS

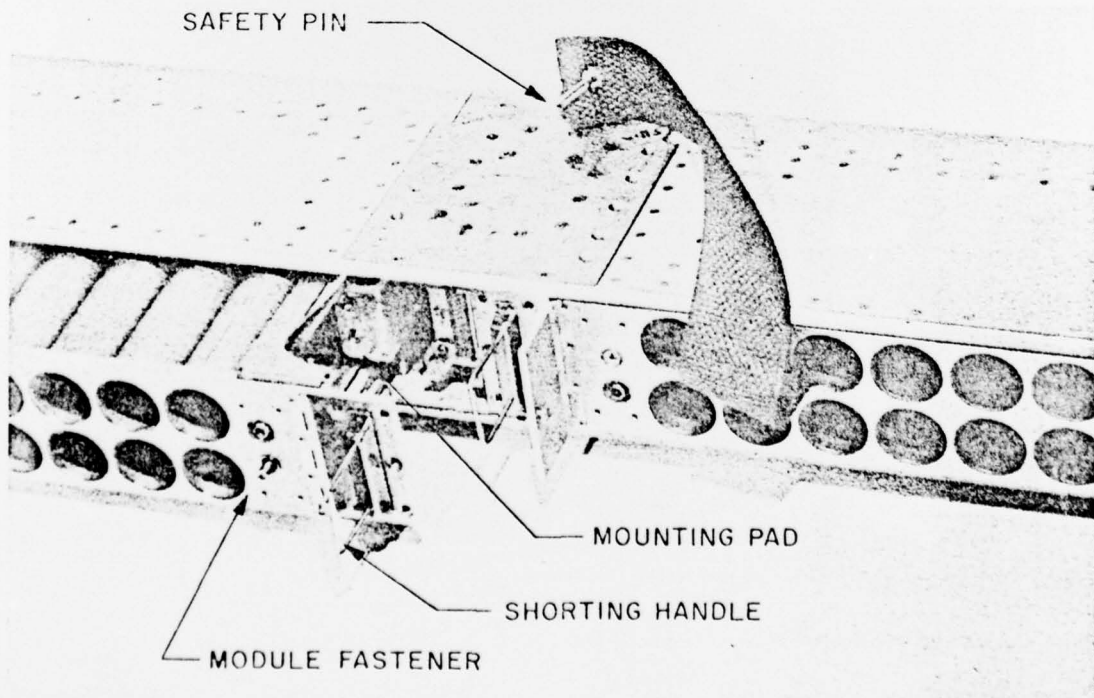



Figure 6 - MODULE (IN POD)



Section IV
INSTALLATION

4.1 Controller. The controller is installed within the aircraft equipment bay by a mounting bracket assembly as shown in Figure 7 and NAOC drawing No. ME19871. The orientation is upside down (i.e., cover is at bottom) with the side containing the receptacles J1, J2 and J3, and the control switches facing aft in the compartment (bay). Four 10-32 screws/bolts are used to attach the controller to the mounting bracket.

CAUTION

The inward protrusion of the mounting screws should not be greater than 3/8 inches from the outside skin surface of the assembly box.

The aircraft cabling is attached to receptacles J1, J2 and J3. Receptacle J1 interconnects the system to the aircraft control signal and power sources. The controller unit is interconnected through the aircraft cabling by receptacle J2 to the right pod and J3 to the left pod.

4.2 Pod Pre-Installation Check. Prior to installing the dispensing pod on the drone, the pod pre-installation test procedure described in VT-TM- must be completed.

4.3 Dispenser Pod Installation (Reference VT-TM-). Install the pods with bolts and safety wire in accordance with drawing number ME18242.

WARNING

All RF transmission in the immediate area should be turned off and personnel should remain clear of the underside of the pods during installation.

Section V
MAINTENANCE

5.1 Pod Recovery Instruction. When the target is returned to base the following pod unloading procedure should be followed prior to performing any decontamination maintenance.

WARNING

Personnel should remain clear of the underside of the PODS during the following steps.

- 1) Insert lanyard pin in top and bottom lanyard switch.
- 2) Disconnect battery according to standard procedure.
- 3) Insert safety pin in pod's center section.
- 4) Insert safety shorting connector with handle in module.
- 5) Remove two (2) Phillips screws located at each end of the module.
- 6) Remove module from the pod.

5.2 Controller. The controller unit is a highly reliable unit and requires no preventative or scheduled maintenance. If malfunction does occur, the entire unit should be removed and returned to the manufacturer for repairs.

5.3 Dispensing Pod Assembly. Damaged or malfunctioning components should be replaced and returned to the manufacturer for repair.

Preventative maintenance procedures include disassembly, cleaning, drying and reassembly of the pod components subsequent to drone recovery. With the payload modules removed, the following procedures are used to disassemble the pod assembly.



- 1) Unscrew and remove the 12 Phillips head screws which hold the nose and tail cones on the pod.
- 2) Pull off the nose and tail cones.
- 3) Remove the 14 Phillips head screws which hold the sequencer unit-cover plate assembly in the pod center section. (See Figure 8.)
- 4) Disconnect the center connector from the sequencer unit and let it hang free.
- 5) Remove the sequencer unit-cover assembly from the pod by tilting the assembly and by gradually extracting it from the pod opening.

5.3.1 Modules. The modules are built to require no scheduled maintenance other than cleaning and drying subsequent to drone recovery. The wire harness assembly (see Figure 9) should be replaced if there is a loss of continuity in one of the wires or if the ground shield around one of the wires becomes broken.

If the firing squibs become loose in their connectors the brass squib sockets in each connector should be replaced. (See Figure 9.)

By pushing the socket out from the back side of the connector with a 1/32" diameter rod, a new socket may then be pushed into place.

The module must be disassembled for decontamination after drone recovery using the following procedure: (See Figure 10.)

- 1) Unscrew and remove three screws which hold the cable harness retainer atop the breech plate.
- 2) Remove the cable harness retainer.
- 3) Remove 4 screws which hold the cable harness floating connector plate to the module face-plate.
- 4) Remove the harness assembly.
- 5) Remove the 4 screws which hold the breech plate from the module.
- 6) Remove the breech plate from the module.

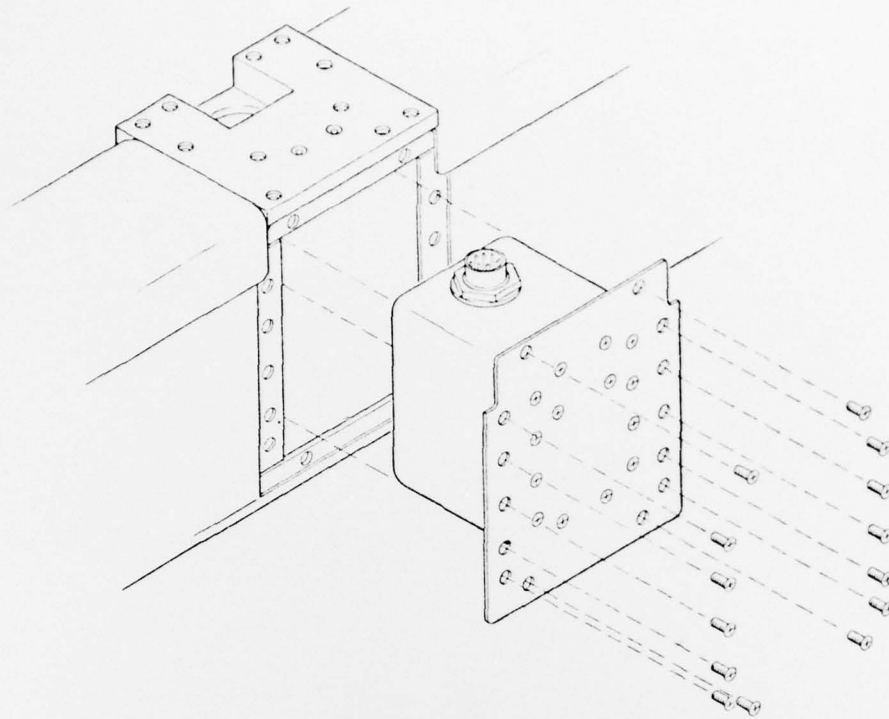

Figure 8 - SEQUENCER DISASSEMBLY

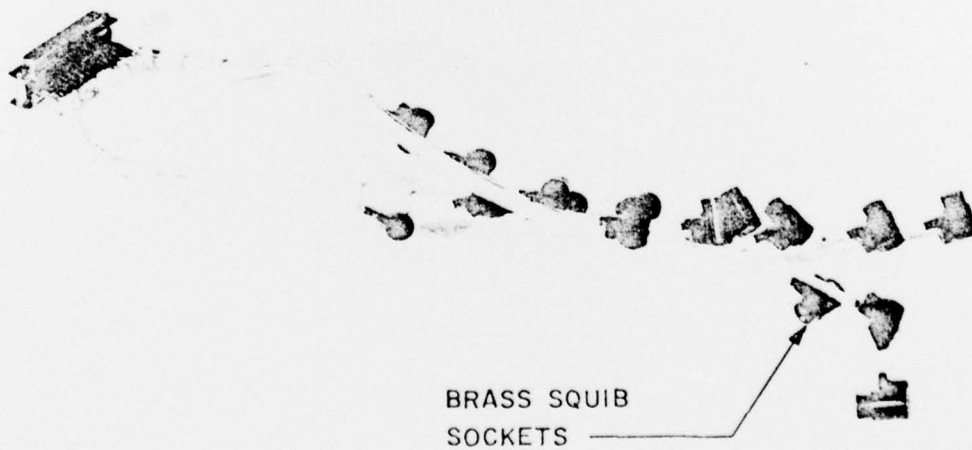

Figure 9 - CABLE HARNESS ASSEMBLY



D12705 (3/75)

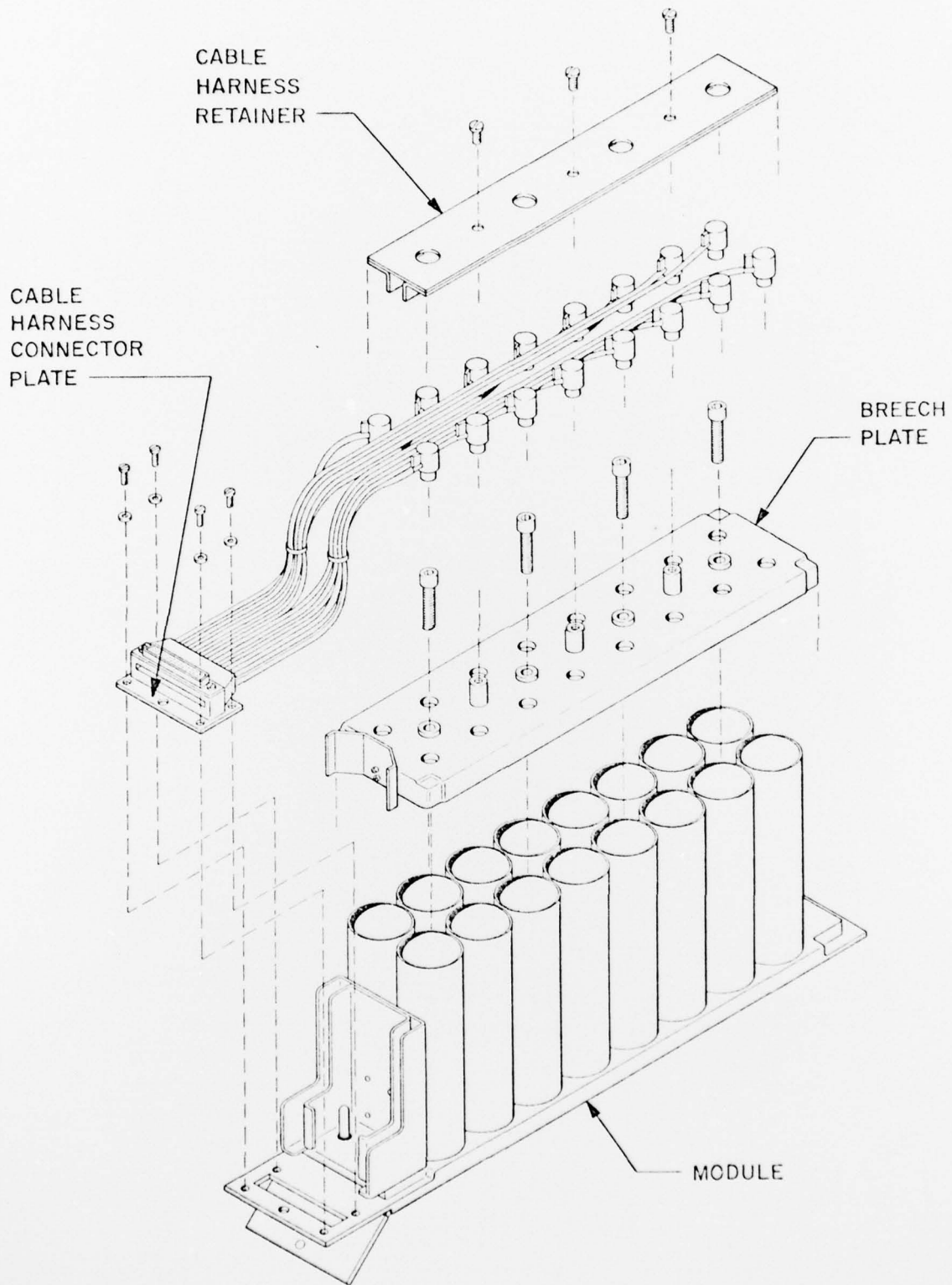

Figure 10 - MODULE ASSEMBLY



5.3.2 Sequencers. The sequencer unit is an environmentally sealed device designed for more than 1 million squib firing sequences. It is considered repairable only at the manufacturer level. It can be removed from the pod center section by removing the 14 attaching screws which hold it in place.

5.4 Decontamination After Salt Water Immersion.

- 1) Total immersion or a thorough hosing with fresh water is required for all components except the cable harnesses and sequencer units which should not be immersed.
- 2) Cable harnesses should be hosed with water directed into the squib pin sockets. The connectors should be shaken, and the sockets blown out with an air hose to completely dry them. They should then be inspected for corrosion.
- 3) After washing, all components should be dried with a cloth and/or oven dried at 125 degrees Fahrenheit. The cable harnesses and sequencer units in particular should be oven or sun dried.

5.5 When the Countermeasures Dispensing Pod, Part No. 39-0300-001 is recovered with the BQM-34 drone, follow basic cleaning procedures as per NAVORD OD 3000 third revision - lubrication of Ordnance Equipment, Chapter 5 - "Cleaners and Preservatives".



Section VI
SAFETY AND HANDLING

6.1 Static and Electrical

6.1.1 Protect operations from electrostatic charges by effectively grounding all machinery, equipment, and fixtures; and, where necessary, employ suitable grounded conductive coverings for floors, work benches and tables, and workers' conductive shoes. Workers' clothing of a type to minimize the accumulation of static charges shall be employed.

6.1.2 The squibs shall be packed in relatively small groups wrapped in bare non-insulated aluminum foil. During assembly and processing operations, such sensitive electric items should be short circuited by clips or other devices until installed in the dispenser assembly. Additional precautions for the squibs should include mechanical shielding to contain or deflect fragments and blast; also electrical shielding from induced electric currents originated by sources such as lightning, static, electromagnetic radiations, etc. Where necessary for safety, humidity of workrooms should be appropriately increased, as required to lessen electrostatic effects, but without inducing excessive moisture absorption by any of the components of the item being processed.

6.1.3 Protect all explosive operations from effects of electric current originating in equipment (such as soldering irons or guns, heaters, switches, wiring, motors, lights, test instruments, etc.) by suitable insulation, grounding, separation or shielding.

6.2 Hazards of Electromagnetic Radiation to Ordnance. Whenever ordnance items containing Electro Explosive Devices (EED) are present, handled, loaded and/or unloaded in Electromagnetic fields, personnel involved should be aware of the hazards of electromagnetic radiation to ordnance (HERO).