

AD-A044 739

SEMCOR INC MOORESTOWN N J

F/G 9/3

THE EXTENSION OF GPMS ARCHITECTURE FOR THE DISTRIBUTION OF AUDI--ETC(U)

MAY 75

N62269-75-C-0326

UNCLASSIFIED

SEMCOR-SK-JJK-75-125-1

NL

| OF |  
AD  
A044739



END  
DATE  
FILMED  
10 -77  
DDC

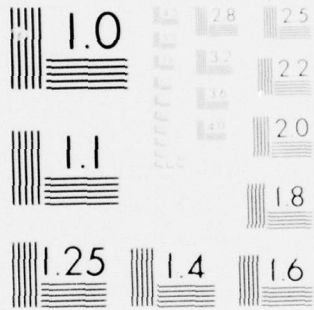

MICROCOPY RESOLUTION TEST CHART  
NATIONAL BUREAU OF STANDARDS-1963-A



**SEMCOR**

Strawbridge Lake Office Building, Moorestown, New Jersey 08057 (609)234-6600

AD A 044739

SEMCOR Report SK-JJK-75-125-1

1  
B/S

THE EXTENSION OF GPMS ARCHITECTURE  
FOR THE DISTRIBUTION OF AUDIO  
SIGNALS WITHIN NAVY AIRCRAFT

(GPMS AUDIO DISTRIBUTION REPORT)

(CDRL ITEM A001)

5 MAY 1975

Prepared Under Contract N62269-75-C-0326

AD No. \_\_\_\_\_  
DDC FILE COPY

for

NAVAL AIR DEVELOPMENT CENTER  
Warminster, Pennsylvania 18974

DDC  
RECEIVED  
SEP 26 1977  
A

**DISTRIBUTION STATEMENT A**

Approved for public release;  
Distribution Unlimited

Regional Offices:

6811 Kenilworth Avenue, Riverdale, Maryland 20840  
Security Pacific Bank Building, San Diego, CA 92108

Telephone (301)277-4400  
Telephone (714)299-5860



**SEMCOR**

Strawbridge Lake Office Building, Moorestown, New Jersey 08057 (609)234-6600

14

SEMCOR Report SK-JJK-75-125-1

11

6

THE EXTENSION OF GPMS ARCHITECTURE  
FOR THE DISTRIBUTION OF AUDIO  
SIGNALS WITHIN NAVY AIRCRAFT .

(GPMS AUDIO DISTRIBUTION REPORT)

(CDRL ITEM A001)

11

5 MAY 1975

12 25 p.

15

Prepared Under Contract N62269-75-C-0326

DDC  
RECEIVED  
SEP 26 1977  
RECEIVED

A

for

NAVAL AIR DEVELOPMENT CENTER  
Warminster, Pennsylvania 18974

DISTRIBUTION STATEMENT A

Approved for public release;  
Distribution Unlimited

Regional Offices:

6811 Kenilworth Avenue, Riverdale, Maryland 20840  
Security Pacific Bank Building, San Diego, CA 92108

Telephone (301)277-4400  
Telephone (714)299-5860

389133

7B

## TABLE OF CONTENTS

<u>Section</u>		<u>Page</u>
1.0	INTRODUCTION .....	1-1
2.0	CHARACTERISTICS OF AUDIO SIGNALS .....	2-1
	2.1 Audio Signals in Navy Aircraft .....	2-2
	2.1.1 Voice Signals .....	2-2
	2.1.2 Non-Voice Signals .....	2-2
3.0	OPERATIONAL CHARACTERISTICS OF AUDIO DISTRIBUTION IN NAVY AIRCRAFT .....	3-1
4.0	DISTRIBUTION OF AIRCRAFT AUDIO SIGNALS BY MULTIPLEXING .....	4-1
5.0	BASELINE SYSTEM ARCHITECTURE .....	5-1
	5.1 System Description .....	5-1
	5.1.1 AT and ACU Functions .....	5-1
	5.1.2 Modulation Technique .....	5-3
	5.1.3 Channel Allocation .....	5-5
6.0	AN ALTERNATE APPROACH TO THE BASELINE SYSTEM .....	6-1
7.0	CONCLUSIONS .....	7-1

ACCESSION for	
NTIS	Write Section <input checked="" type="checkbox"/>
DDC	Buff Section <input type="checkbox"/>
UNANNOUNCED	<input type="checkbox"/>
JUSTIFICATION	
<i>Letter on file</i>	
BY	
DISTRIBUTION AVAILABILITY CODES	
Dist.	AVAIL. and/or SPECIAL
A	

## 1.0 INTRODUCTION

This report presents the results of an engineering study performed to investigate possible ways of extending the basic General Purpose Multiplex System (GPMS) architecture to handle the distribution of audio signals within Navy aircraft. The study is a systems engineering look at the problems of multiplexing the aircraft audio signals and at methods by which this multiplexing can be accomplished.

The subjects covered are presented essentially in sequence according to the chronological order in which the study proceeded. The first discussion on the general characteristics of audio signals is followed by a description of the types of audio information found in Navy aircraft. The operational characteristics and requirements of audio distribution systems in typical Navy aircraft are then presented. The aircraft selected for this purpose are the A-7E (Corsair II) and the P-3A (Orion), which represent opposite ends of the spectrum with respect to aircraft size and audio requirements. The A-7E is a single-seat attack aircraft, while the P-3A is a four-engine ASW patrol aircraft with 14 flight crew stations.

After the general audio distribution requirements are established, the subject of multiplexing is addressed. The major considerations involved in the design of an audio multiplex system are discussed, and a baseline architecture is described together with an alternative and somewhat more sophisticated approach. For both approaches, the rationale leading to the choice of modulation technique, transmission medium, and other multiplex parameters is stated.

This report neither recommends nor rejects the implementation of audio multiplexing in Navy aircraft. A decision to multiplex or not to multiplex audio signals must ultimately be supported by analyses of cost-effectiveness, system space and weight considerations, and impact on mission effectiveness. Such analyses were not undertaken in this study.

## 2.0 CHARACTERISTICS OF AUDIO SIGNALS

The degree to which the basic GPMS architecture must be extended to accommodate the transfer of audio information is fundamentally dependent upon the characteristics of the audio signals and their compatibility with existing GPMS information transfer mechanization. The important characteristics of audio signals relevant to Navy aircraft are:

1. Audio signals occupy a baseband frequency range of from 300 to 3000 Hz. Exceptions to this rule exist but they comprise only a small portion of aircraft audio information; e.g., audio signals received from passive sonobuoys such as submarine engine and propeller sounds or underwater explosions contain frequency components below 300 Hz.
2. Audio signals as transferred in most communications systems are highly redundant with regard to information content (that is, compared with the information that could be transmitted within the same bandwidth). For example, the use of vocoders permits speech information to be digitized and transmitted at rates as low as 1200 bits/second. The redundancy present in the audio signals, however, makes them more tolerant of noise and other interference. For example, audio information that has been digitally coded using Pulse Code Modulation (PCM) or Delta Modulation (DM) techniques can tolerate bit error rates that are orders of magnitude greater than BER's tolerated by digital data messages.
3. Audio messages are sporadic and of long duration compared to data messages of the type employed in GPMS. The latter occupy communication channels for microseconds or milliseconds, whereas audio messages can occupy channels for seconds or minutes. Even in voice multiplex systems employing TASI\* techniques<sup>(1)</sup>, the minimum average "speech burst" is as long as 500 to 600 milliseconds. Speech burst is the length of time in which a talker is actually speaking before a pause.

---

\*TASI (Time Assignment Speech Interpolation) is a technique predicated upon the fact that in a voice communications system, subscribers do not talk constantly but pause between words and phrases and therefore need not occupy a channel for the full duration of a conversation (as in the case of normal commercial telephony). Hence, in a TASI system, a subscriber occupies a channel only while he is actually speaking. When a pause is detected, the channel is withdrawn and reassigned to a different party. When the subscriber resumes talking, he is immediately assigned the first idle channel that is available. TASI is somewhat akin to a GPMS without polling.

As will be seen later in the report, the long duration characteristic of audio messages is an extremely important factor in determining the eventual architecture for audio multiplexing within a GPMS framework.

4. The design of audio communications systems is strongly influenced by human factors considerations, especially in the case of voice communications. In the transmission and reception of voice signals, for example, intelligibility alone of the information transferred is often not a sufficient criterion for evaluating performance. Other factors such as voice recognition and speaker mood recognition are also required. Thus, in the selection of a voice processing technique, the ultimate choice is heavily weighted by subjective as well as objective values.

## 2.1 AUDIO SIGNALS IN NAVY AIRCRAFT

The type of audio signals found in present Navy aircraft can be divided into two broad categories: voice and non-voice.

### 2.1.1 Voice Signals

Of the two classes, voice signals make up the dominant audio information distributed throughout the aircraft. Voice signals are used for two purposes:

1. Interior communications between crew members via the Intercommunication System (ICS).
2. Exterior communications via radio.

Voice signals are characterized by a complex spectrum composed of frequency components in the 300-3000 Hz range.

### 2.1.2 Non-Voice Signals

Non-voice audio signals are typically characterized by tones, which are either continuous, interrupted, or a combination of the two. They are used for identification purposes to apprise the pilot or other aircrew members of the status of some equipment or aircraft function, and as alarms and warnings of critical conditions requiring prompt action.

Some examples of non-voice audio are TACAN station identification, audio signals from a beacon receiver, missile audio indicating seeker lock-on, Mode IV IFF audio, audio output from communications receivers operating in a CW mode, warning signals from an ECM receiver, and low altitude warnings from the radio altimeter. Non-voice audio signals can also have a complex frequency spectrum as is the case of submarine sounds from sonobuoy receivers.

As can be seen from the examples given, non-voice signals are essentially of a receive-only nature.

### 3.0 OPERATIONAL CHARACTERISTICS OF AUDIO DISTRIBUTION IN NAVY AIRCRAFT

Modern Naval aviation is composed of a large variety of aircraft with a wide diversity of missions and equipment. The operational characteristics that govern the conduct of audio communications for a given aircraft are greatly influenced by the missions and equipment associated with that aircraft.

In order to determine the operational characteristics (which define the operational requirements for an audio multiplex system) and still keep the study effort within reasonable bounds, the following approach was taken. The audio distribution systems of two different Navy aircraft were examined, the A-7E (Corsair II) and the P-3A (Orion). Besides being representative of opposite aircraft types with regard to size and audio distribution requirements, the A-7E and P-3A were chosen because information concerning their audio systems was readily available.

The A-7E is a single-place, carrier-based attack aircraft. All audio signal transfers, except one, are between the pilot and avionics equipment in which audio frequency inputs and outputs are required. The one exception is an intercom function that permits the pilot to communicate with personnel outside the aircraft during deck operations. The intercom function is supplied by the AN/AIC-25 Intercommunications Set, which also provides the mixing and amplification of all audio inputs to the pilot's headset. References (2), (3), and (4) indicate that six to eight audio signals are distributed in the aircraft.

The P-3A is a four-engine, shore-based ASW patrol aircraft. Audio distribution is effected by the AN/AIC-22 system,<sup>(5)</sup> which provides intercommunications among 14 flight crew stations and four ground crew stations. The AIC-22 also provides radio monitoring, and where applicable, transmitter control to the flight crew stations. Approximately 20 to 25 different audio signals are distributed throughout the P-3A aircraft (see reference 5).

Based upon an examination of the AN/AIC-25 and AN/AIC-22 and their use in the A-7E and P-3A aircraft, the following observations are presented with regard to the operational nature of aircraft audio communications:

1. In a large aircraft such as the P-3A, voice communications among crew members inside the aircraft (as well as ground crew personnel outside the aircraft) are on a line-group or net basis. Table 1, derived from reference (5), shows the nine line groups in the P-3A.
2. No requirement for selective private calling such as is found in dial telephone systems appears to exist. The CONF #1 and CONF #2 lines provide the capability for selective calls, but call privacy is obviated by the fact that any crew member can monitor these lines at any time.
3. In large aircraft with multiple crew stations, a requirement exists for incoming audio in certain nets to be connected to designated stations at all times, regardless of the position of that station's net selective control. Note in Table 1 that seven of the line groupings in the P-3A have this feature.
4. In large aircraft intercommunication systems, certain crew stations are equipped with one or more of the following features:
  - a. Disconnect - With this feature, the station can disconnect all incoming ICS audio for the purpose of devoting full attention to conducting radio communications.
  - b. Override - Stations with this feature are capable of overriding the disconnect feature in a. above.
  - c. PA (Public Address) Control - Stations with this feature can actuate loudspeakers located at certain other crew stations. Table 1 shows the Public Address line group for the P-3A. Note that only six crew stations are equipped with speakers, and PA control is vested with the pilot and copilot.
5. Signaling of crew stations to switch to a given net is accomplished by the call originator verbally contacting net members over the ALL net and simply directing them to switch control to the desired net.
6. In both small and large aircraft, each crew station with the capability of monitoring radio receivers must be capable of monitoring each receiver individually on a selective basis or more than one receiver simultaneously if so desired. One example of the latter case is that of a pilot performing a landing approach. In this instance the pilot desires to monitor audio signals from the ground beacon and at the same time maintain radio contact with the control tower via his communication transceiver.

TABLE 1. INTERCOMMUNICATION LINE GROUPING FOR P-3A

	ICS LINE	ALL	PILOT-COORD. LINE	FLIGHT CREW GROUP	NAV LINE	ASW GROUP	OBSER GROUP	CONF #1	CONF #2	OVERRIDE CONTROL	ICS DISCONNECT*	PUBLIC ADDRESS (HDSTS & SPKRS)
NOSE WHEELWELL		X										
PILOT		X	X	X	X	O	O	O	O	E	D	CXS
COPILOT		X		X	X	O	O	O	O	E	D	CXS
FLIGHT ENGINEER		X		X				O	O			X
RADIO OBSERVER		X		O	X	O	O	O	O		D	XS
FWD R.H. OBSERVER		X		O		O	X	O	O			X
RADAR-MAD		X		O		X		O	O			X
JULIE-ECM		X				X		O	O		D	X
NAVIGATOR		X		O	X	X	O	O	O		D	X
TACTICAL COORDINATOR		X	X	O	X	X	O	O	O	E	D	XS (2)
JEZEBEL OPERATOR		X				X		O	O		D	X
ARMAMENT LOADER		X				X		O	O			XS (3)
AFT R.H. OBSERVER		X		O		O	X	O	O			X
AFT L.H. OBSERVER		X		O		O	X	O	O			X
GALLEY		X		O		O	X	O	O			XS
TAIL BOOM		X										
L.H. INBD NACELLE		X										
R.H. INBD NACELLE		X										

LEGEND

- X Incoming call connected at all times regardless of selection at that station.
- O Incoming call connected when selected at that station.
- C Control of PA                      D Ability to disconnect ICS.
- S Loudspeaker Installed.          E Override Control of Disconnected Stations.

#### 4.0 DISTRIBUTION OF AIRCRAFT AUDIO SIGNALS BY MULTIPLEXING

As stated in Section 1.0, the objective of the engineering study was to investigate approaches to the audio distribution problem by extension of the basic GPMS architecture. DOD standardization efforts, which will culminate shortly in a military standard for aircraft data multiplex systems, plus the emphasis on GPMS were major forcing functions in developing the conceptual design approaches for audio distribution within an aircraft. Thus, at the outset of this phase of the study, the following decisions were made:

1. All control functions of a discrete or digital nature should be transferred via GPMS data buses. Such control functions include:
  - a. Communication transmitter and receiver activation, channel selection, and volume control. In short, all devices with audio inputs and outputs can be turned on and off, tuned, and otherwise controlled via GPMS. This concept is not a new one and was basic to the GPMS operational philosophy already used in an A-7E simulation study<sup>(6)</sup>.
  - b. Signaling between audio terminals. An Audio Terminal (AT) is defined as the interface between a user generating baseband audio frequency information and the multiplex bus over which the information is to be transferred. It is analogous to the Data Terminal (DT) in GPMS.
  - c. Loudspeaker control, including connection and muting.
  - d. ICS disconnect functions and disconnect overrides.
2. Insofar as it is possible, the audio multiplex hardware should use standard GPMS components. To this end, the audio multiplex system should employ:
  - a. Twisted-Shielded-Pair (TSP) cables as the transmission medium.
  - b. GPMS line drivers, receivers and cable taps.

3. Time Division Multiplex (TDM) is the recommended multiplexing technique for the following reasons:
  - a. TDM is inherently compatible with digital signal transmission. Since audio signals can be sampled and digitized, the use of TDM is consistent with the objectives of item 2, namely, the use of standard GPMS hardware.
  - b. TDM provides flexibility in bandwidth and signal-to-noise tradeoffs and can be made insensitive to circuit non-linearities. The latter feature eliminates intermodulation distortion problems such as those that occur in Frequency Division Multiplex (FDM) systems. Interchannel interference (crosstalk) is more easily controlled in TDM than in FDM systems.
  - c. The present availability of digital circuit components in the form of integrated circuits and their trend toward smaller size and lower cost make TDM an attractive choice for handling aircraft audio signals.
  - d. A TDM system is easily adaptable to fiber optic cables when these devices gain wider acceptance in communications systems.
  - e. Long-range DoD planning (e.g., TRI-TAC) calls for the eventual encryption of voice and data information to achieve secure communications for all military air-to-air and air-to-ground links. As a consequence, the implementation of all digital communications is being emphasized by the military services. The inherent compatibility of TDM with digital signal transmission (noted in a) would offer definite advantages in effecting the interface between interior and exterior aircraft voice communications.
4. The digitized audio signals to be transferred by the TDM system should be Manchester II encoded and transmitted at a 1.0 M bit/second rate in a half-duplex manner. The transmission rate and Manchester II encoding are recommended for the same reasons that they are presently employed in GPMS. The half-duplex operation is dictated by the net or "conference call" nature of aircraft audio operations.

Following the decision to employ TSP cables as the audio transmission medium, a brief investigation was conducted into the feasibility of transferring the digital audio signals and the GPMS data signals on a common set of buses. The approach taken was to attempt the transfer of audio in the same asynchronous

manner as the data messages are transferred in GPMS. Each burst of audio would be treated as a block message. The baseband audio signal would be sampled at an 8 kHz rate, converted into PCM, and assembled into GPMS message format. The received messages would then be buffered and the PCM samples clocked out at precisely 8 kHz and reconverted to baseband audio.

The data bus would be held for the duration of the burst of audio and then relinquished to the next user requesting service for either an audio or data transfer. In effect, the concept is that of a TASI system with the addition of a stricter bus access control through the use of polling.

Aside from the technical problem of buffering and retiming the audio information to account for transport delay effects, the prime objection to the concept of asynchronous audio transfer stems from the disproportionality between the bus holding time of audio messages compared to data messages. The longest data message (512 words, 20 bits per word) in GPMS at a data rate of 1.0 M bit per second occupies a data bus for 10.2 milliseconds. The average shortest speech burst (and speech is the predominant form of audio information to be transferred) would occupy a bus for 500 to 600 milliseconds. In any reasonable sized GPMS architecture, the audio information would almost certainly overload the capacity of the system. For this reason, the use of asynchronous audio transfer over common buses carrying data information is rejected. The design approach should employ:

1. Separate TSP cables for the audio information.
2. Synchronous fixed-frame TDM channelization on each audio cable.

## 5.0 BASELINE SYSTEM ARCHITECTURE

Figure 1 depicts the system architecture for the first approach to the extension of GPMS to handle the distribution of audio signals. The upper portion of the figure shows the conventional GPMS architecture for data message transfer. The lower half shows the conceptual architecture for audio signal transfer. The audio segment utilizes the same type of TSP cable, cable taps, stubs and terminations as does GPMS. The two major elements in the audio portion of the system are the Audio Terminal (AT) and the Audio Control Unit (ACU).

### 5.1 SYSTEM DESCRIPTION

#### 5.1.1 AT and ACU Functions

The AT is the point of entry to the system for baseband audio information just as the Data Terminal (DT) is the point of entry for baseband data signals in GPMS. The major functions of the AT are:

1. A/D and D/A conversion of the audio information.
2. Channel control. That is, the AT contains the control logic that switches the audio users to the appropriate time slots necessary for communications. Channel selection commands from audio users are transmitted and received via GPMS Data Terminals. Note in Figure 1 that each AT is connected to a DT for this purpose.

The function of the ACU is to provide synchronization information to the AT's that are connected to those cables under the ACU's control. The ACU performs this function by transmitting a coded signal (e.g., a 3-bit invalid Manchester signal) at the beginning of each TDM frame.

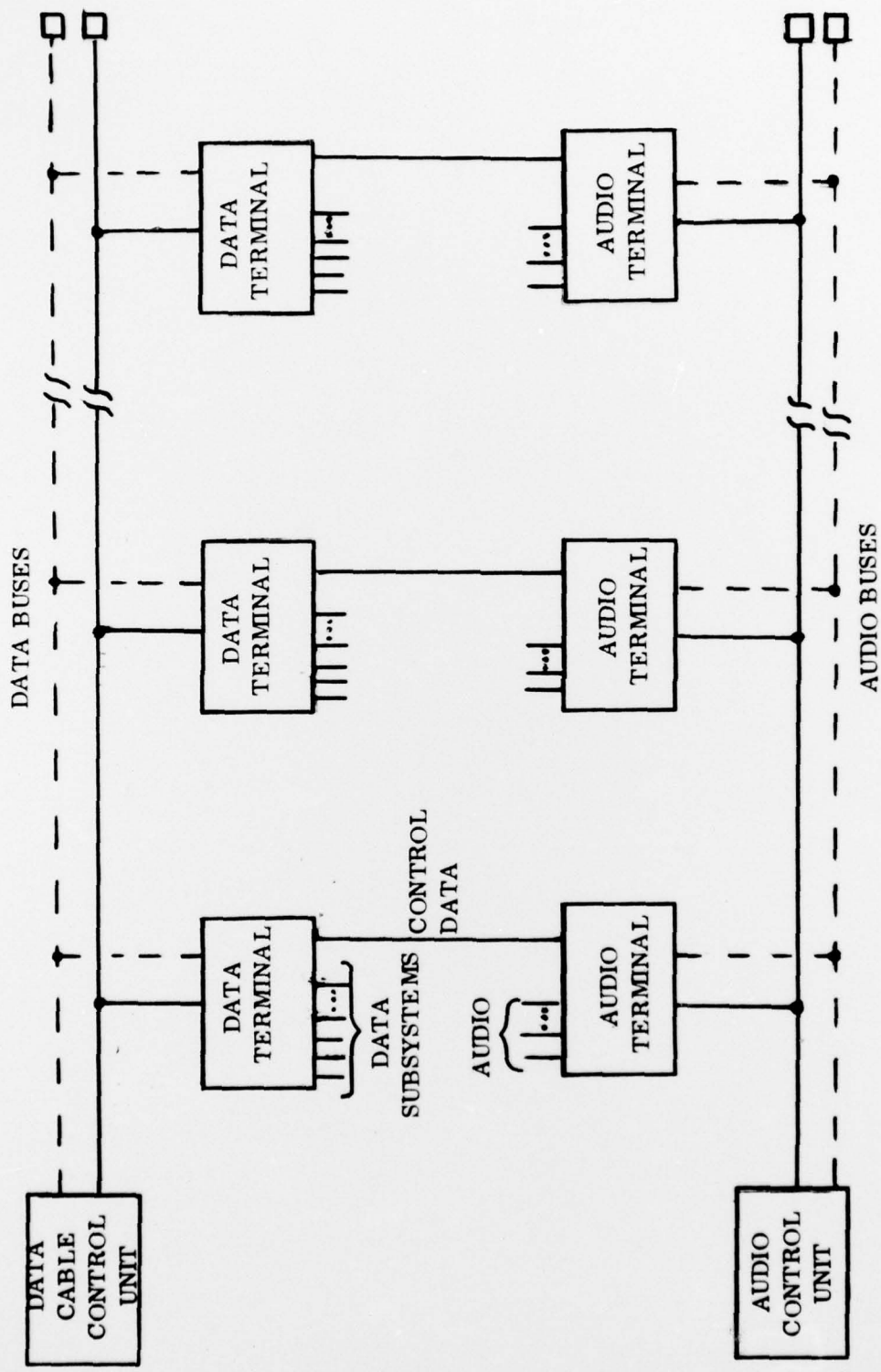

Figure 1. Baseline System Architecture

### 5.1.2 Modulation Technique

The modulation technique employed in the baseline system has been narrowed down to two candidates:

1. Pulse Code Modulation (PCM) with a 5- or 6-bit quantization level and an 8 kHz sampling rate. Six-bit PCM provides very good speech reproduction and is currently employed by the U.S. Army telephone communication system. Five-bit PCM would not produce as good a quality of voice reproduction and has a signal-to-quantization noise ratio 6.0 dB poorer than the 6-bit PCM. However, it might be adequate for aircraft audio requirements. An experimental aircraft ICS system using 5-bit PCM has been built and tested with good results for the U.S. Navy (Navy Contract N62269-2817).
2. Delta Modulation (DM). DM is an outgrowth of PCM (specifically Differential PCM). In the early stages of development, DM performance was poor both from the viewpoint of voice quality and that of quantization noise. Improved performance was obtained at the expense of higher audio sampling rates with a resultant bandwidth penalty. Recent developments in adaptive DM techniques have resulted in lower bit rate DM systems that are competitive in performance with PCM. Therefore, an alternate possibility for digitizing aircraft audio signals is 19.2 kbit/sec Continuously Variable Slope Delta Modulation (CVSDM).

The ultimate selection of a digital modulation techniques is governed, aside from audio quality and signal-to-noise considerations, by:

1. Bandwidth Utilization. The transmission rate recommended for the digitized audio signals is 1.0 M bit/second. Allowing for a 3-bit framing signal and a 1-bit guard interval\* between each channel time-slot, the number of channels available with 5-bit PCM at the 8-kHz sampling rate is about 20. Under the same conditions, 19.2 kbit CVSDM yields 24 channels. Figure 2 illustrates the time structure of typical TDM frames for the PCM and DM cases.

---

\*The distributed nature of the users of the audio multiplex system within the aircraft necessitates a guard-interval between channels to prevent intersymbol interference. This guard interval should be at least as long as the round-trip transmission delay of the full cable length. A 1-bit (i.e., 1  $\mu$ sec) guard interval was chosen as a conservative design parameter and corresponds to a cable length of 250 feet (assuming a 2 nsec per foot delay for TSP cable).

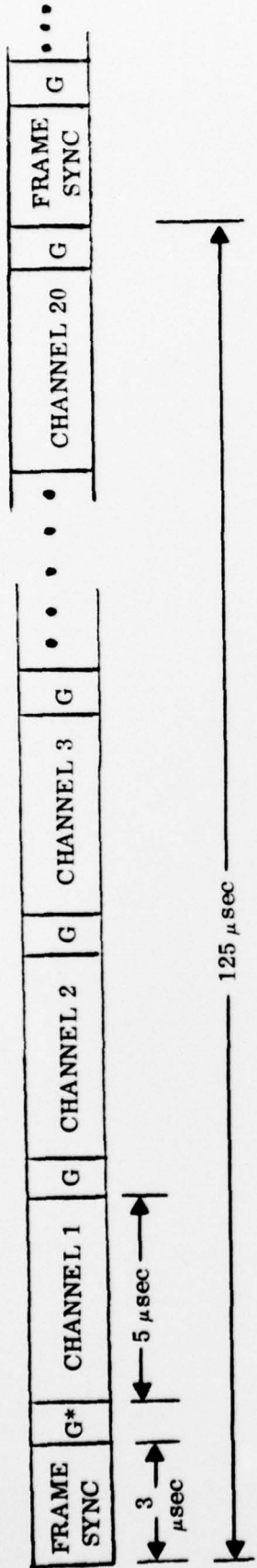

(a) Channelization for 5-bit Pulse Code Modulation

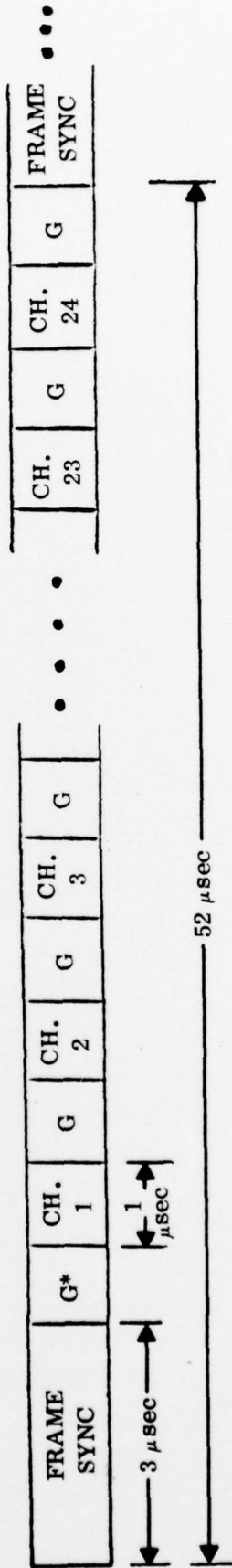

(b) Channelization for 19.2 Kbps Delta Modulation

\*G - Guard Interval = 1  $\mu\text{sec}$

Figure 2. Channel Structures for TDM Audio Buses

2. Cost. Since Delta Modulation does not require A/D and D/A converters and has less stringent audio filtering requirements than Pulse Code Modulation, it is generally believed to be cheaper to implement. However, with the present state of IC technology, the difference in cost between DM and PCM may not be significant. A cost analysis should be undertaken to compare the two modulation schemes in this regard.

### 5.1.3 Channel Allocation

As pointed out in Section 3.0, ICS communications in aircraft operate on a line group or net basis. Also operating mostly on a net basis is the monitoring of communication receivers by air crew personnel. Since virtually all audio communications aboard the airplane are conference calls on line groups or nets, a dedicated channel approach was adopted in the baseline system. In this approach, each function such as a particular ICS line group, a transmitter-receiver, or other audio device is assigned a unique channel (i.e., time slot). This approach minimizes the control problems associated with signaling and supervision and provides for system simplicity.

Each audio cable provides 20 or 24 audio channels depending upon the digital modulation technique chosen. Since channel requirements range between six for small aircraft and 25 for large aircraft, the audio distribution needs of a majority of Naval aircraft can probably be served with a single cable (discounting redundancy requirements) using the dedicated channel approach. For the P-3A, however, the number of channels provided by a single audio cable is presently marginal as well as inadequate from a standpoint of system growth potential. To achieve additional channel capacity in this case, an additional audio cable could be added to provide at least 20 more channels. The two-cable system would permit a total of at least 40 audio functions to be multiplexed on a dedicated channel basis. However, doubling the number of cables would also necessitate doubling the hardware (A/D and D/A converters, line drivers and receivers, etc.) in the AT's.

An alternate approach to achieve more TDM channels on a single cable is to increase the transmission rate of the audio information from the presently recommended 1.0 M bit/second rate.

## 6.0 AN ALTERNATE APPROACH TO THE BASELINE SYSTEM

The alternate approach discussed in this section differs from the baseline system in one area only -- channel allocation. The baseline system is predicated upon dedicated channels, one for each audio function. In the alternate approach, channel assignment is on a non-dedicated basis. Channels are assigned according to user service requests in a manner similar to that of GPMS. Two advantages gained from this approach are:

1. Dynamic active redundancy such as that inherent in GPMS could be achieved. In the dedicated channel philosophy of the baseline system, redundancy is of a standby nature requiring switchover in the event of primary cable outage. A non-dedicated channel allocation system would be adaptive, with no switchover required.
2. Better survivability is achieved in the case of very large systems, i. e., in systems where the number of audio functions exceeds the channel capacity of a single cable. If a dedicated channel system (redundant or otherwise) is left with one surviving cable, some audio functions will be completely lost. However, in a non-dedicated channel system, although the grade of service (GOS)\* will be poorer when only one cable is available, all audio functions can still be served by the surviving cable.

The benefits to be gained from a non-dedicated channel allocation approach, however, are not without penalty, and the penalty to be paid manifests itself primarily in the amount and complexity of the supervision required. For example, in the baseline system no account is kept of channel status since each channel is dedicated to a particular audio function. Consequently no communication is necessary between Audio Control Units and Audio Terminals (other

---

\*Grade-of-service is a system design parameter that originated in commercial telephony. It is defined as the probability that, during a specified period of peak traffic, a call originated by a party will be lost or delayed on the first attempt due to the unavailability of an idle channel. GOS is sometimes called probability of loss or blocking probability. A typical GOS requirement for military communication systems is 0.001, i. e., one call out of every thousand will be blocked.

than the synchronization information on the audio buses). In the alternate system, however, each ACU must keep track of the status of the audio channels under its control and the status of every AT in the system. To this end, communications must be maintained between ACU's and AT's. Reasons for this requirement are presented in the following discussion.

Consider first the problem of channel allocation. In order to assign a channel upon receipt of a service request from an AT, an ACU must know which of the channels under its control are busy and which channels are idle.

The determination of the busy/idle status of a channel by the ACU is a more complex operation in the audio multiplex system than it is in GPMS. In the latter, a simple energy detector in the Cable Control Unit can perform this task. However, the absence of energy in an audio channel does not necessarily signal the end of channel usage. For example, in a voice conference on an ICS net, there can be long pauses or lulls in conversation under normal operating conditions. These lulls preclude the use of energy detection as a criterion for determining that the net users want to relinquish the channel. Therefore, the intentions of the audio users must be communicated to the ACU.

A further complication in the problem of channel assignment is related to the efficient use of the channels available in the system. For example, suppose one crew station desired to monitor a particular receiver. The service request is made, a channel is assigned, and monitoring begins. Suppose a second crew station then wishes to monitor the same receiver. Assigning a different idle channel for this function would be wasteful. If the second request for service had gone to the same ACU that assigned the channel at the first service request, no great problem would result. Since the ACU knows that the receiver audio is already on a given multiplex channel, the ACU need only direct the second listener to that same channel. However, in a system with redundant ACU's, the second service request may have been made to a different

ACU. Since the ACU's are independent and unaware of each other's actions, the second ACU would assign a new channel to the second listener. To prevent this dual assignment of channels for the same audio function, communication between AT's and ACU's is again necessary.

To provide the communication necessary for supervision of the audio multiplex system, a form of polling will be employed. Each ACU will periodically request data from each AT to determine present AT status. This function will be accomplished via the GPMS DT's and data buses according to normal GPMS protocol for sink-originated periodic messages.

The data message from an AT to an ACU will contain information denoting the operational state of the AT, i. e., whether the AT is presently engaged in audio communications, and if so, which audio function is involved. The data message will also contain requests from the AT to initiate audio service as well as requests to discontinue service and relinquish the channel in use. Each ACU will process the received data messages and store the appropriate information to keep track of the system status at all times. When a request for service is received, the ACU will examine its listing of available channels and assign an idle channel to all participants involved in the communications. Thus, if an AT requests a net call, the ACU will assign the channel to all members of that net. If the request is for receiver monitoring, the ACU will assign the channel to the receiver output and to all stations authorized to monitor the receiver. A channel will remain assigned to an audio function as long as the AT data messages to the ACU indicate that someone is using that function. In this way, duplicate channel assignments are avoided.

The assignment of channels from ACU's to AT's can be effected by multiple sink data messages via GPMS or directly over the audio cables by allocating a control channel for that purpose. The latter method has the dual advantages of

faster message delivery and reduction of the GPMS data message load. However, it reduces the number of available audio channels per cable since one or more time slots would have to be dedicated to the control function.

## 7.0 CONCLUSIONS

1. The audio distribution requirements of Naval aircraft have been analyzed, and two conceptual multiplex architectures extending GPMS have been presented to serve those requirements.
2. Time Division Multiplex is the recommended technique for audio multiplexing.
3. The modulation technique, either PCM or DM, requires further study (particularly with regard to cost) before one or the other is chosen.
4. Of the two architectures presented -- the baseline system and the alternate system -- the former is simpler but less flexible or efficient than the latter. The alternate system is more complex from a signaling and supervision standpoint and requires a more sophisticated ACU.
5. The ACU in the alternate system will require some form of small computer. The suitability of using a microprocessor should be investigated.
6. Finally, the decision as to whether to multiplex aircraft audio at all will depend upon a tradeoff analysis between the cost and complexity of such a system and the benefits to be gained by its employment. These benefits are very dramatic in the case of data multiplex systems such as GPMS, but have, as yet, not been clearly established for audio multiplex.

## REFERENCES

1. Presto, A. F., Optimal Digital Voice Transmission, Report No. RADC-TR-72-277, ITT Defense Communications Division, Nutley, New Jersey, November 1972.
2. Introduction to the A-7E, Corsair II, Training Technology Document 2-56223/1P1-EP-100, Vought Aeronautics Company, LTV Aerospace Corporation, Dallas, Texas.
3. NATOPS Flight Manual, Navy Model A-7E Aircraft, Document No. NAVAIR 01-45AAE-1, NAVAIRSYSCOMHQ, Washington, D.C., 1 March 1973.
4. Avionics Interface Data Summary, AIDS No. 1, A-7D Communications Subsystem, Document No. SCI-74-TR159, Systems Consultants, Inc., Ridgecrest, California, November, 1974.
5. NATOPS Flight Manual, Navy Model P-3A and P-3B Aircraft, Document No. NAVAIR 01-75PAA-1, NAVAIRSYSCOMHQ, Washington, D.C. 1 July 1970 (Revised 1 April 1972).
6. A Computer Simulation Study of the General Purpose Multiplex System (GPMS) Applied to the Information Transfer Requirements of the A-7E Aircraft, Volume I Methodology and Results, SEMCOR Report SR-JJK-74-289-1, SEMCOR, Inc., Moorestown, New Jersey, 16 October 1974.