

AD-A044 826

FRANK J SEILER RESEARCH LAB UNITED STATES AIR FORCE --ETC F/G 17/7  
A VIBRATIONAL ANALYSIS OF THE FECKER INERTIAL TEST TABLE, (U)  
AUG 77 G D EVANS

UNCLASSIFIED

FJ-SRL-TR-77-0014

NL

1 OF 1  
ADA  
044826

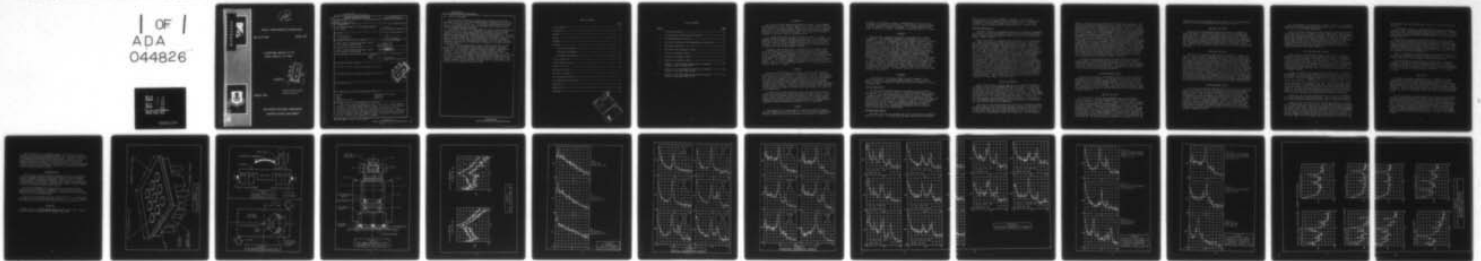

END  
DATE  
FILMED

10-77  
DDC

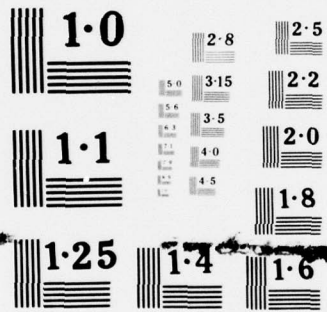

NATIONAL BUREAU OF STANDARDS  
MICROCOPY RESOLUTION TEST CHART

ADA 044826



*P2  
NW*

FRANK J. SEILER RESEARCH LABORATORY

SRL-TR-77-0014

AUGUST 1977

A VIBRATIONAL ANALYSIS OF THE  
FECKER INERTIAL TEST TABLE

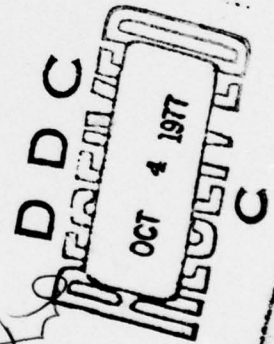

SCIENTIFIC

APPROVED FOR PUBLIC RELEASE;  
DISTRIBUTION UNLIMITED.

PROJECT 2304

DDC  
FILE COPY



AIR FORCE SYSTEMS COMMAND  
UNITED STATES AIR FORCE

UNCLASSIFIED

SECURITY CLASSIFICATION OF THIS PAGE (When Data Entered)

REPORT DOCUMENTATION PAGE		READ INSTRUCTIONS BEFORE COMPLETING FORM
1. REPORT NUMBER FJ SRL-TR-77-0014 AD A-	2. GOVT ACCESSION NO.	3. RECIPIENT'S CATALOG NUMBER
4. TITLE (and Subtitle) A VIBRATIONAL ANALYSIS OF THE FECKER INERTIAL TEST TABLE	5. TYPE OF REPORT & PERIOD COVERED Scientific	
7. AUTHOR(s) G. Douglas Evans	8. CONTRACT OR GRANT NUMBER(s) 17 F21	
9. PERFORMING ORGANIZATION NAME AND ADDRESS Frank J. Seiler Research Laboratory (AFSC) ✓ USAF Academy, Colorado 80840	10. PROGRAM ELEMENT, PROJECT, TASK AREA & WORK UNIT NUMBERS 16 DRS 61102F 2304-F2-63	
11. CONTROLLING OFFICE NAME AND ADDRESS Frank J. Seiler Research Laboratory (AFSC) 11 USAF Academy, Colorado 80840	12. REPORT DATE August 1977	
14. MONITORING AGENCY NAME & ADDRESS (if different from Controlling Office) 12 26p.	13. NUMBER OF PAGES 21	
16. DISTRIBUTION STATEMENT (of this Report) Approved for public release; distribution unlimited.	15. SECURITY CLASS. (of this report) UNCLASSIFIED	
17. DISTRIBUTION STATEMENT (of the abstract entered in Block 20, if different from Report)	15a. DECLASSIFICATION/DOWNGRADING SCHEDULE	
18. SUPPLEMENTARY NOTES	DDDC RECEIVED OCT 4 1977 ALC/STW/BU	
19. KEY WORDS (Continue on reverse side if necessary and identify by block number) Iso-pad Pier Shaker Inertial Test Table	Portable Seismic Monitor Seismometer Resonance	
20. ABSTRACT (Continue on reverse side if necessary and identify by block number) The Inertial Guidance Research Division of the Frank J. Seiler Research Laboratory at the USAF Academy employs a Fecker Inertial Test Table for use in inertial instrument testing. The test table is mounted on a seismic isolation pad (iso-pad) to provide a motionless test environment. Sensors on the iso-pad detect seismic activity of the pad and provide motion correction signals to actuators through a feedback system. The actuators keep the iso-pad free of motion due to external disturbances. → over		

319 920

mt

UNCLASSIFIED

SECURITY CLASSIFICATION OF THIS PAGE(When Data Entered)

20. Abstract (continued)

The iso-pad motion correction system rolls off above 20 Hz to avoid actuating the pad at or near its natural resonant frequencies of 59, 65, and 67 Hz, thus avoiding instabilities. A DC-20 Hz motion-correction frequency band is also adequate for the inertial instrument tests conducted by the Inertial Guidance Research Laboratory.

The Inertial Test Table is investigated for natural resonant frequencies within the 20-50 Hz range. Such resonances are known to exist and cause instabilities in the system because the system frequency response is not completely attenuated at the frequencies where these resonances lie. The test table is excited through the iso-pad with vertical, horizontal, and rotational motion, and the resonant peaks are plotted across the DC-50 Hz frequency spectrum for each of the three modes of vibration. The test table resonant frequencies are detected by placing EV22C seismometers at various locations on the test table.

A strong resonant peak occurs at 22 Hz in both the vertical and horizontal modes. The rotational resonant peak occurs at 34 Hz. Extensive alterations to the test table structure caused no changes in amplitude or frequency of the resonances. However, the resonant peaks shifted in frequency as the test table mounting bolt lengths were varied. This indicates that the test table resting on the three mounting bolts acts as a spring mass system. Changing the length of the mounting bolts changes the spring constant, which affects the natural resonant frequency of the system. The resonant frequency of the test table is a function of its mounting structure and not due to a component within the system.

UNCLASSIFIED

SECURITY CLASSIFICATION OF THIS PAGE(When Data Entered)

## TABLE OF CONTENTS

	<u>Page</u>
List of Figures -----	2
Introduction -----	3
Problem -----	3
Purpose -----	3
Apparatus -----	4
Procedure -----	4
Vertical Measurements -----	4
Horizontal Measurements -----	4
Rotational Measurements -----	5
Initial Calibration -----	5
Iso-Pad Reference Signal -----	6
Vertical Test Data -----	6
Horizontal Test Data -----	7
Rotational Test Data -----	7
Possible Resonant Sources -----	7
Test Table Mounting Structure -----	8
Conclusions -----	9
Recommendations -----	10
References -----	10

ACCESSION for  White Section

B.I. Section

---

DATE: \_\_\_\_\_

BY: \_\_\_\_\_

---

DISTRIBUTION:  GENERAL  SPECIAL

A

LIST OF FIGURES

<u>Figure</u>		<u>Page</u>
1	Iso-Pad Construction -----	11
2	Iso-Pad Vertical and Horizontal Excitation -----	12
3	Iso-Pad Rotational Excitation -----	12
4	Test Table Construction and Seismometer Test Locations -----	13
5	PSM Channel Matching -----	14
6	Pad (Reference) Seismometer Signals -----	15
7	Vertical Seismometer Signals -----	16
8	Horizontal Seismometer Signals -----	17
9	Rotational Seismometer Signals -----	18
10	Effects of Test Table Mounting Structure on Resonant Frequency (Vertical Mode at TP5) -----	19
11	Effects of Test Table Mounting Structure on Resonant Frequency (Horizontal Mode at TP5) -----	20
12	Effects of Test Table Mounting Structure on Resonant Frequency (Rotational Mode at TP5) -----	21

## INTRODUCTION

The Inertial Guidance Research Division of the Frank J. Seiler Research Laboratory at the U. S. Air Force Academy employs a Seismic Isolation Pad for use in inertial instrument testing. Ideally, the isolation pad, or "iso-pad", should be free of any motion caused by external influences such as building vibrations or seismic activity of the earth. This motionless environment is required for successful inertial instrument testing.

The iso-pad construction is shown in Figure 1 on page 11. Twenty pneumatic actuators support a 450,000 lb concrete block. Nine concrete piers, connected to the main block, protrude through the laboratory's false floor. These piers serve as the test locations for experiments requiring seismic isolation. The false floor is rigidly connected to the building, while the iso-pad floats freely on the pneumatic actuators.

Attached to the concrete block is a seismometer and tiltmeter sensor array which detects any motion of the iso-pad due to external disturbances. The sensors will generate a signal which is proportional to the mechanical motion in both amplitude and frequency. This signal is amplified and directed to the appropriate actuators which provide a correction to the original disturbance. The pneumatic actuators provide low frequency motion correction below 0.1 Hz. This cutoff frequency is determined by an electronic filter network. Above 0.1 Hz, iso-pad motion correction is provided by eight electromagnetic actuators, or shakers.

## PROBLEM

The upper cutoff frequency of the motion correction system has been selected at 20 Hz by the designers as a performance trade-off. The iso-pad block resonates at 59, 65 and 67 Hz. If the motion correction system operates at or near these frequencies, the seismometers will detect, and the shakers will amplify the resonance and introduce instabilities into the system. Therefore, the low-pass cutoff frequency must be sufficiently below these iso-pad resonant frequencies, while at the same time be high enough to provide adequate seismic isolation. The motion-controlled frequency band of DC-20 Hz is also adequate for presently foreseen iso-pad applications, e.g., gyro and accelerometer tests.

An Owens-Illinois Fecker Systems Division 2-axis Inertial Test Table is located on the north-center pier of the iso-pad as shown in Figure 1. The table is known to resonate at various frequencies slightly above the 20 Hz system cutoff frequency. Because of the close proximity of these resonant frequencies to the system's active frequency spectrum, these resonances are detected and amplified somewhat by the system, causing instability.

## PURPOSE

The purpose of this investigation is to determine where the natural resonant frequencies of the test table lie within the DC-50 Hz region, where they occur within the structure, and whether the resonances are vertical,

horizontal, or rotational in nature. A determination will also be made as to whether the resonances are caused by a single component within the table or by the composite structure of the table. If a single component of the table is causing the resonance, an attempt to locate the source will be made.

## APPARATUS

The test table vibrations are measured with matched pairs of EV22C seismometers. (All subsequent references to seismometers will be to the EV22C's.) Two vertical seismometers and two horizontal seismometers are used in this investigation. A Random Noise Generator (RNG) is used to produce white noise from DC-50 Hz. This signal is amplified and used to drive the shakers which in turn cause the entire iso-pad to vibrate with random noise. This noise is transmitted to the Inertial Test Table through the test pier. The seismometers, mounted to the test table with cellulose-nitrate cement, produce signals that are proportional to the amplitude and frequency of the test table vibrations. The seismometer signals are then amplified and equalized by a four-channel Portable Seismic Monitor (PSM). The EV22C electrical characteristics and PSM operation are explained fully in Reference 1. The PSM output signals are fed through a 50 Hz low pass filter and input to a Fourier analyzer. The analyzer processes one pair of seismometer signals at a time. The analyzer averages ten signal samples for each channel and provides a decibel relationship for channel A, channel B, and (A-B) across the frequency spectrum from DC-50 Hz. Results of the Fourier analysis are recorded on an X-Y plotter. The resonant frequencies of the test table appear as peaks on the dB plots.

## PROCEDURE

Investigations of the table's natural resonant frequencies in the vertical, horizontal, and rotational modes were made. Figures 2 and 3 on page 12 illustrate the methods of table excitation used to examine the various vibrational modes.

### Vertical Measurements

The north and south shaker arrays are actuated in phase to provide vertical excitation as shown in Figure 2. Two vertical seismometers, labeled "1V" and "2V", are used to measure the test table vibrations. Seismometer 1V is cemented directly to the iso-pad pier and provides a pad-only vibration reference signal. Seismometer 2V is located at six predetermined test points, TP1 through TP6, on the table as shown in Figure 4 on page 13. These seismometer test locations trace the changes in frequency and amplitude of vibration throughout the structure. The signal from the pad-mounted seismometer is subtracted from that of the table-mounted seismometer, and the resultant signal provides table-only vibration data.

### Horizontal Measurements

Horizontal vibrations are measured with a pair of horizontal seismometers labeled "3H" and "4H". The north and south shaker arrays are actuated out of

phase to provide a horizontal component of motion as shown in Figure 2. Seismometer 3H is a pad-mounted reference seismometer, while seismometer 4H is mounted at locations TP1 through TP6 on the test table. As with the vertical analysis, the 4H-3H signal provides table-only vibrational data.

### Rotational Measurements

Rotational vibrations are detected with a pair of horizontal seismometers. The iso-pad is excited rotationally by a pair of horizontally-mounted electromagnetic shakers located at opposite corners of the iso-pad and actuated in-phase as shown in Figure 3.

Because the shakers are mounted at opposite corners of the iso-pad, the pad's center of rotation will occur at the center test pier. Ideally, the test table should be mounted on the center pier for rotational analysis. However, the table is located on the north-center test pier, ten feet from the iso-pad center of rotation. Therefore, the test table will travel in an arc of ten foot radius about the center of the pad. Figure 3 shows the arc about the center of the pad and the resultant rotational component vectors of motion. For each shaker half-cycle, the iso-pad rotates through angle  $\theta$ , and the rotational component vectors will be of equal magnitude and opposite direction. The seismometers are mounted in the same direction with their axes colinear with the rotational component vectors so that a half-cycle excitation of the iso-pad will cause out of phase signals to be generated by the seismometers. These out of phase signals, when subtracted by the Fourier analyzer, will produce a sum signal showing rotational resonant peaks. The seismometers should be insensitive to the horizontal motion component because their sensitive axes are nearly perpendicular to the rotational arc as shown in Figure 4. Also, any horizontal component which moves the two seismometers equidistant in the same direction should cause the seismometers to produce in-phase signals which are canceled by the Fourier analyzer during the signal-subtracting process. Ideally, therefore, only resonant peaks due to rotational motion should appear in the final plots.

### INITIAL CALIBRATION

Because the rotational analysis makes use of very small differences in seismometer signals, each seismometer/PSM amplifier channel of a vertical or horizontal pair must be closely matched to its complement. The proper PSM-to-seismometer matching procedure is explained in Reference 1. However, the PSM amplifier gains should be matched for each channel pair by the experimenter because previous channel matching does not have a long shelf life. The EV22C's are labeled 1V, 2V, 3H, and 4H, as are the PSM channels. 1V and 2V are vertical channels, while 3H and 4H are horizontal channels. The EV22C's are not interchangeable among PSM channels after a seismometer has been matched to a particular PSM amplifier per Reference 1.

Both vertical and horizontal amplifier matching are accomplished through the same process, and only the vertical matching procedure is described. The paired seismometers to be used in the experiment are mounted side by side on a glass plate. The glass pivots about two steel balls at one end and is activated by an electromagnetic shaker at the other end. The electromagnetic

shaker is excited by an audio oscillator at 8 Hz and 32 Hz separately. The signals from the two PSM channels are fed to a differential amplifier, and the subtracted signal is displayed on an oscilloscope. The EV22C's naturally resonate at 8 Hz. This resonant peak is attenuated by placing a resistor of proper value across the seismometer terminals, providing an RL damping network with the seismometer coil. The seismometers used in this investigation had been previously damped and matched at 8 Hz. The 8 Hz test revealed that the seismometers were still adequately matched with respect to damping after a shelf life of approximately one year. The amplifier gain matching was accomplished at 32 Hz. The gain potentiometer of one PSM channel in each pair is adjusted to its center of rotation. The gain potentiometer of the complementary channel is rotated until the signal from the differential amplifier displayed on the oscilloscope shows a minimum amplitude. At this point, the amplifier gains should be as closely matched as practicable. As a final check for proper channel matching across the entire frequency spectrum, the RNG is used to excite the shaker with white noise from DC-50 Hz. The plot of the 2V-1V signal across the frequency spectrum is then compared to the plot of the 1V signal alone to determine the degree of channel matching. The PSM channel matching results are shown in Figure 5 on page 14.

The vertical channel matching error is under 8% while the horizontal error is under 1.1% with respect to voltage level in the 20-50 Hz band. Although the mismatch error is higher at lower frequencies, the vibrational analysis only focuses on the 20-50 Hz band. The horizontal channel matching is the more critical of the two because the rotational vibrational analysis relies on closely-matched horizontal seismometers.

#### ISO-PAD REFERENCE SIGNALS

The vertical, horizontal, and rotational pad-only reference signals are presented in Figure 6 on page 15. The vertical and horizontal signals are each generated by a single seismometer cemented to the pad, while the rotational signal is the difference between the two signals generated by seismometers arranged as shown in Figure 3. The three plots in Figure 6 show no significant peaks in the iso-pad itself across the frequency spectrum. Therefore, any peaks which appear in the test table plots will indicate test table resonant frequencies.

#### VERTICAL TEST DATA

The plots of the vertical test seismometer signals are presented in Figure 7 on page 16. The plots presented are of the reference signal subtracted from the test signal, or the "corrected" signal. Refer to Figure 4 to trace the progression of the test procedure. TP1 through TP3 indicate a consistent resonant frequency at 22 Hz throughout the main test table supporting structure. TP4 through TP6 also indicate a strong and consistent resonant peak at 22 Hz, as well as minor peaks at 31 Hz and 34 Hz. Because the 22 Hz peak is consistent throughout the entire test table structure, it is suspected that this resonant frequency is a function of the composite test table structure. However, because the 31 Hz and 34 Hz peaks appear only at TP4 through TP6, the resonant source is suspected to be somewhere within the

center section of the test table, and a possible source is the bearings which allow the structure to rotate about axis C-C shown in Figure 4.

#### HORIZONTAL TEST DATA

The plots of the corrected horizontal test signals are presented in Figure 8 on page 17. As with the vertical signals, a large resonant peak occurs near 22 Hz. However, unlike the vertical signals, minor resonant peaks occur at 31 Hz and 34 Hz throughout the entire test table. Once again, the consistent 22 Hz peak throughout the structure indicates the possibility that this resonant frequency is a function of the composite test table structure. However, the 31 Hz and 34 Hz peaks appear to be strongest at TP4, which indicates that these peaks could possibly be caused by the counterweight structure.

#### ROTATIONAL TEST DATA

The plots of the rotational test signals are presented in Figure 9 on page 18. A pair of plots is presented for each test point. The plot on the left is of the 3H signal only, which is very similar to the 4H signal plot. The plot on the right is the 4H-3H signal. The resonant peaks due to rotation are determined by comparing the 4H-3H plot to the 3H-only plot. The peaks which appear significantly larger in the 4H-3H plot than in the 3H plot are peaks due to rotation. Peaks which appear unchanged or smaller in the 4H-3H plot are due to horizontal motion. This signal evaluation method is described under "Rotational Measurements" on page 5. A rotational peak appears consistently at 34 Hz from TP1 through TP5. A minor peak also appears at 32 Hz at the same table locations. Vibrational analysis in the rotational mode is very difficult due to the horizontal components introduced into the testing which are of much greater magnitude than the rotational components. An ideal method of performing a rotational analysis on the test table would involve mounting the test table on the center pier, so only rotational motion would be present.

#### POSSIBLE RESONANT SOURCES

The vertical and horizontal resonant peaks at 31 Hz and 34 Hz, which only appear in the center of the test table structure, indicate that the counterweight structure or the A-A and C-C rotational axis bearings may be the resonant sources. Refer to Figure 4 for the following investigation. The counterweight structure appeared to be a probable source of resonance. The nuts were tightened on the counterweight bolts and an increase in frequency of the 31 Hz and 34 Hz peaks was expected. However, the resultant plots revealed no change in resonant frequency. Half of the counterweights and finally all of the counterweights were removed. Again, the 31 Hz and 34 Hz peaks remained unchanged. A removal of the counterweight bolts from the structure also caused no changes in the plots. The 22 Hz peak also remained constant throughout the test.

As a second measure, the air pressure, normally at 90 PSI, was completely removed from the air bearing along the A-A rotational axis. Again, the 22 Hz, 31 Hz, and 34 Hz peaks remained unchanged.

Finally, the center section of the test table was rotated through 90° to a horizontal position in an attempt to isolate the mechanical bearings along the C-C axis as a resonant source. Once again, the resultant plots showed no changes when compared to the plots of Figures 7, 8, and 9. The resonant peaks, then, because of their constant frequencies throughout the test table and throughout alterations to the structure, must be a function of the composite test table structure. The test table mounting structure was suspected to be a resonant source because of the constant frequency of the resonant peaks despite structural alterations.

#### TEST TABLE MOUNTING STRUCTURE

Refer to Figure 4 for the following description of the test table mounting structure. The test table, weighting 1500 pounds, is supported by three 5/8 inch leveling bolts. The normal exposed length of the threaded portion, or shaft of the bolt is typically one inch. The test table is secured to the pier with three 14-1/2 inch hold-down bolts which are fastened at the top with nuts and are threaded into the mounting ring. The mounting ring is rigidly fixed to the test pier. The hold-down bolts were both tightened and loosened completely, but the resultant plots showed no changes in resonant frequency.

Finally, the effect of the leveling bolts on the resonant frequency was investigated. The test table, resting on the three bolts, forms a spring-mass system, with the table being the mass, and the leveling bolts serving as the spring. The natural resonant frequency of a spring-mass system,  $\omega_n$ , is given by the equation  $\omega_n = \sqrt{\frac{k}{m}}$ , where  $k$  is the spring constant and  $m$  is the mass of the system. By lowering the test table, the effective shaft length of the leveling bolts is shortened to 3/4 inch. This procedure would raise the spring constant, causing  $\omega_n$  to increase. Therefore, by lowering the test table, the resultant plots should show an increase in the natural resonant frequency. The test table was lowered and the effects were recorded at TP5, which provides a representation of the effects on the entire test table.

Figures 10a and 10b on page 19 show that the 22 Hz peak has shifted to 25 Hz upon shortening of the leveling bolts. The 31 Hz and 34 Hz peaks have not shifted but have decreased in amplitude to nearly insignificant levels.

Figures 11a and 11b on page 20 also show the same increase in frequency of the resonant peak from 22 Hz to 25 Hz. A minor peak also appears at 20 Hz as a result of the change. This minor peak appears inconsistently throughout the testing process and is suspected to have been possibly transmitted through the iso-pad from a separate source on another test pier within the laboratory. Finally, Figures 12a through d on page 21 show an increase in rotational resonant frequency from 34 Hz to 38 Hz upon lowering of the test table. The plots also reveal that the rotational peaks are more easily discernable from

the horizontal peaks during rotational testing when the mounting bolts are shortened.

A preliminary conclusion is drawn that the mounting structure plays a significant role in introducing test table resonant frequencies. To further verify this claim, the test table was mounted on three 4 in. x 4 in. x 2 in. wooden blocks, allowing no contact to be made between the leveling bolts and the mounting ring.

Because the wood blocks are a much softer material than the leveling bolts, the spring constant should be lower, resulting in a decrease in  $\omega_n$ . Figure 10c shows that the vertical peak has shifted from 22 Hz to 14 Hz when a wooden mounting structure is used. The 38 Hz peak has shifted down into the DC-50 Hz range from a previous frequency above 50 Hz. Very minor peaks at 30 Hz and 34 Hz are still present, indicating that they most likely are not functions of the mounting structure.

Figure 11c indicates that the horizontal resonant peak at 22 Hz has shifted to 14 Hz when the test table is mounted on wood blocks. Again, this resonant peak appears to be a function of the mounting structure.

Figures 12e and 12f indicate that the rotational peak at 34 Hz has shifted to 25 Hz when the table is mounted on wooden blocks. The data presented in Figures 10, 11, and 12 indicate that the 22 Hz resonant peak is a function of the test table mounting structure, while Figure 10 indicates that the 31 Hz and 34 Hz peaks are possibly independent of the mounting structure.

#### CONCLUSIONS

The test table naturally resonates at 22 Hz throughout the entire structure both in vertical and horizontal modes when the length of the leveling bolt shafts is one inch. Under the same conditions, a 34 Hz rotational resonant frequency occurs consistently throughout the table. Minor resonant frequencies occur at 31 Hz and 34 Hz in the vertical modes from TP4 through TP6. However, these minor resonant peaks appear consistently throughout the test table in the horizontal vibrational mode, but appear strongest at TP4.

Various alterations to the test table structure produced no perceptible changes in resonant frequency in any of the three vibrational modes. However, when the leveling bolts were effectively shortened to 3/4 inch by lowering the test table, the vertical and horizontal resonant peaks shifted from 22 Hz to 25 Hz, while the rotational resonant peak at 34 Hz shifted to 38 Hz. Mounting the test table on wooden blocks lowered the vertical and horizontal resonant frequencies from 22 Hz to 14 Hz, while the rotational resonant frequency shifted from 34 Hz to 25 Hz. The 31 Hz and 34 Hz peaks, however, were not significantly affected by the alterations to the mounting structure.

The test table forms a spring-mass system with its natural resonant frequency a function of the mounting structure. The minor peaks at 31 Hz and 34 Hz possibly originate from within the test table. They most likely are not transmitted to the table via the iso-pad from a remote structure on another pier because no peaks at 31 Hz nor 34 Hz appear in the pad-only reference signal plots in Figure 6. The transmission of these two frequencies through the pad is possible, however, because the iso-pad motion correction system is only effective up to 20 Hz.

#### RECOMMENDATIONS

Various types of mounting structure materials should be substituted in place of the wooden blocks and the various effects on the table's natural resonant frequencies should be investigated. Materials such as aluminum or steel would not be subjected to changes in density due to compression over a length of time, as is the wood. Therefore, the frequency-damping characteristics of these materials would remain constant.

All of the seismometer test points used in this investigation are external test table locations. Seismometers should be placed inside the center portion of the test table structure in an attempt to locate the source of the 31 Hz and 34 Hz resonant peaks.

Finally, an investigation into the iso-pad itself should be conducted to determine if the 31 Hz and 34 Hz resonant frequencies are transmitted through the iso-pad to the test table from a remote location on the iso-pad.

#### REFERENCES

1. Simmons, Bill J. Portable Seismic Monitor User's Guide, Frank J. Seiler Research Laboratory Report No. SRL-TR-74-0006, March 1974.

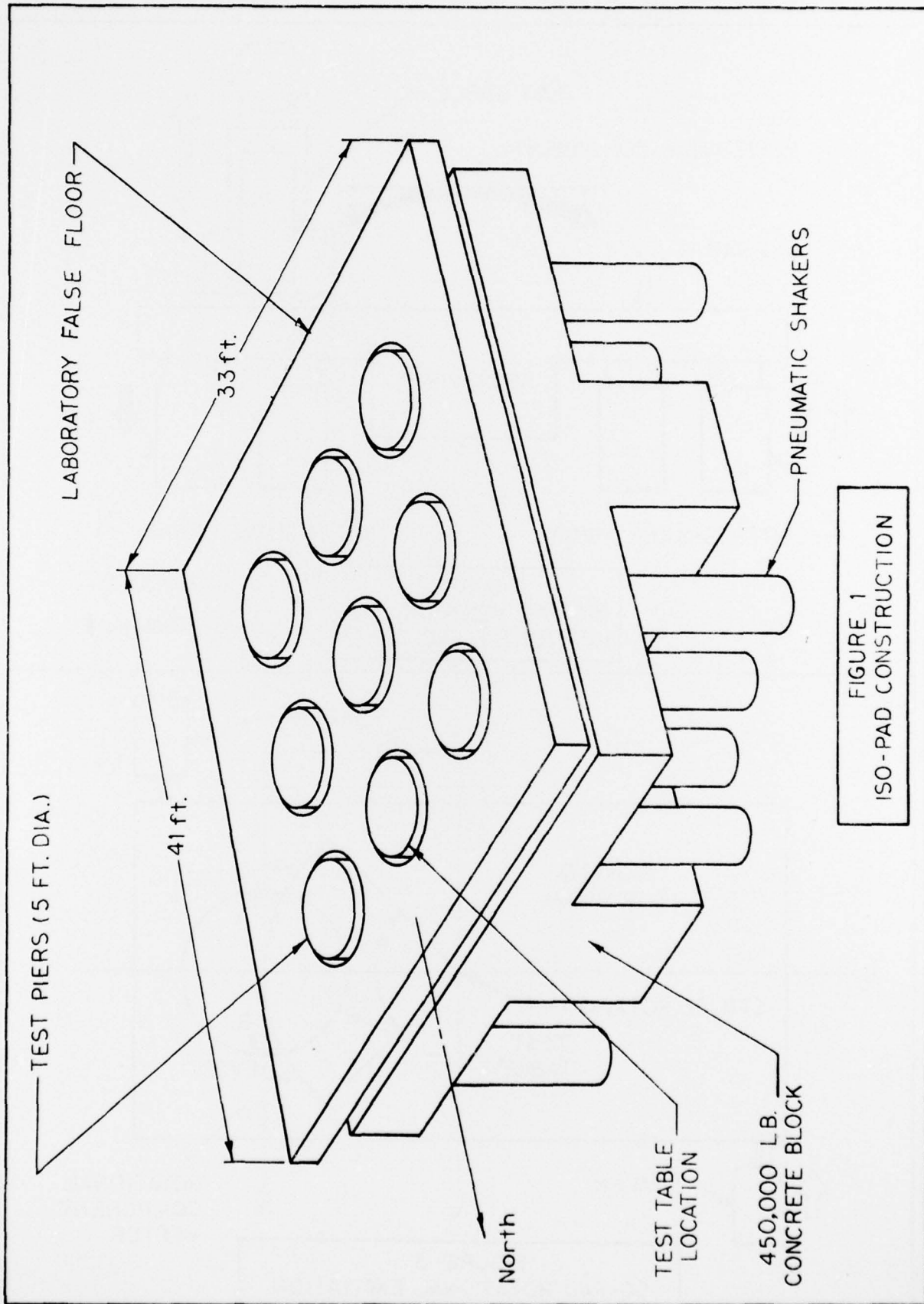
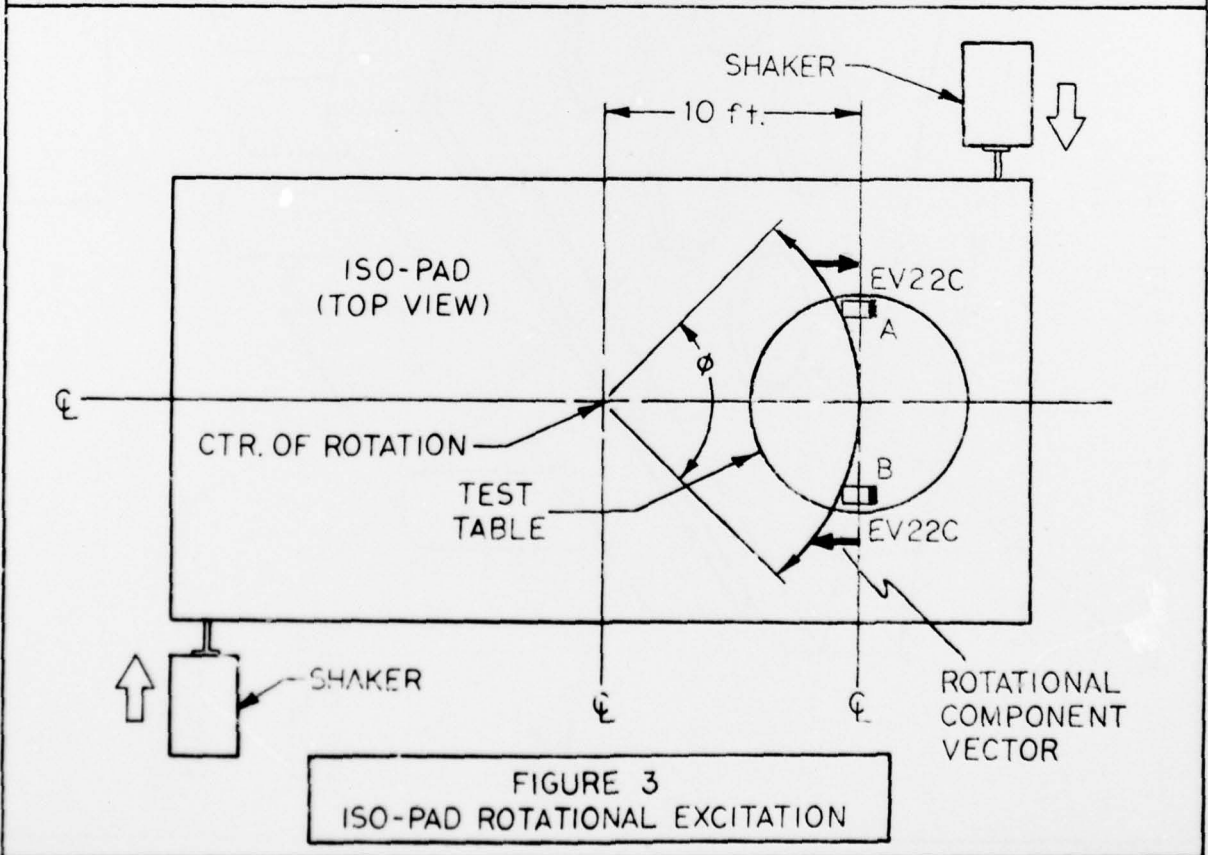
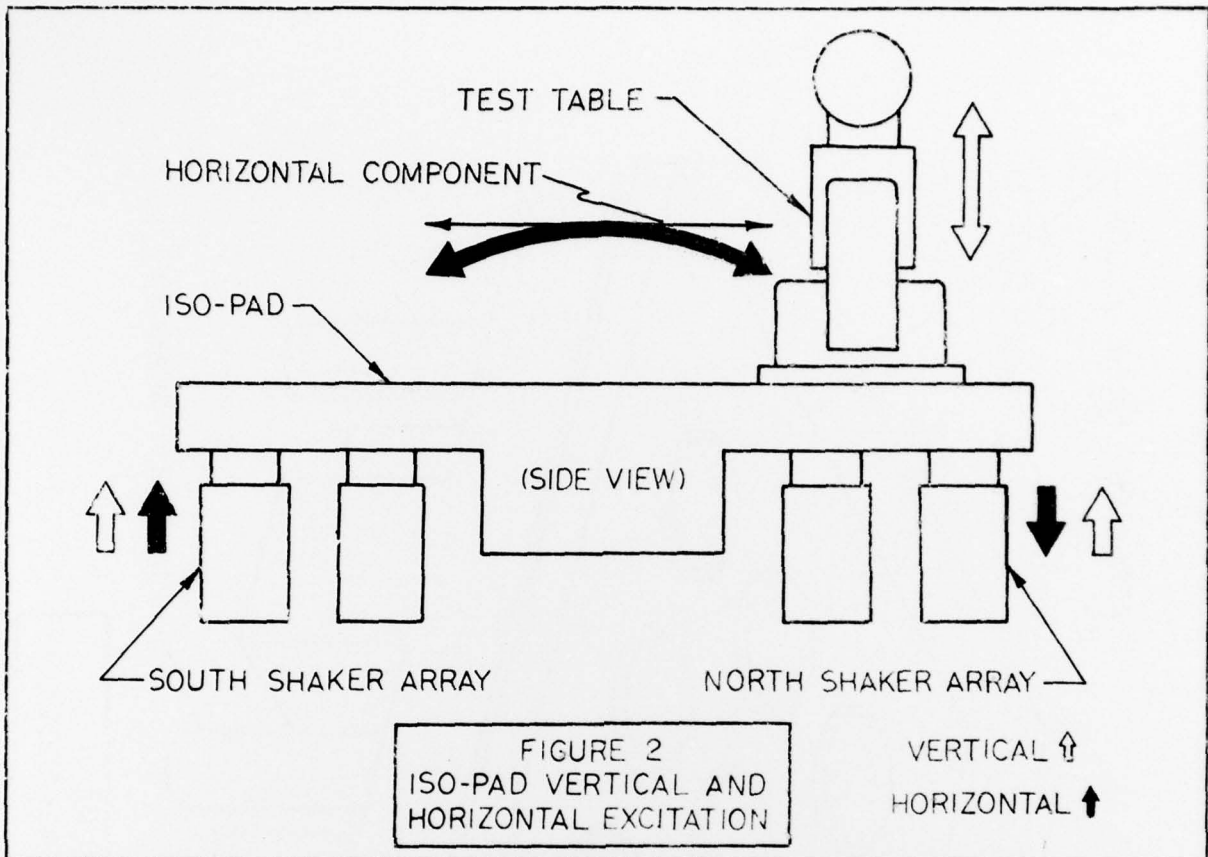

FIGURE 1  
ISO-PAD CONSTRUCTION



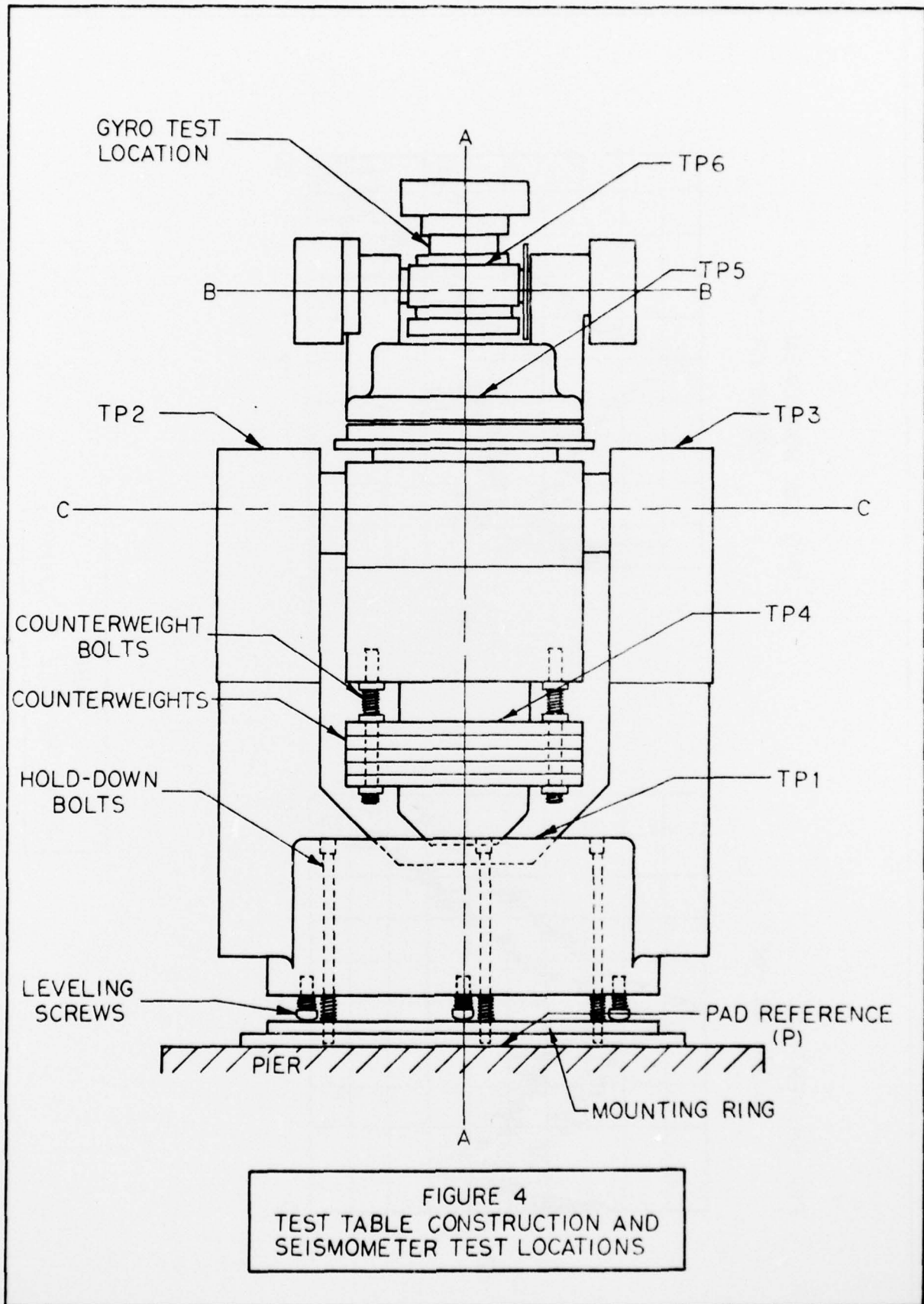

FIGURE 4  
 TEST TABLE CONSTRUCTION AND  
 SEISMOMETER TEST LOCATIONS

FIG. 5a: VERTICAL  
0.001 dB ref.

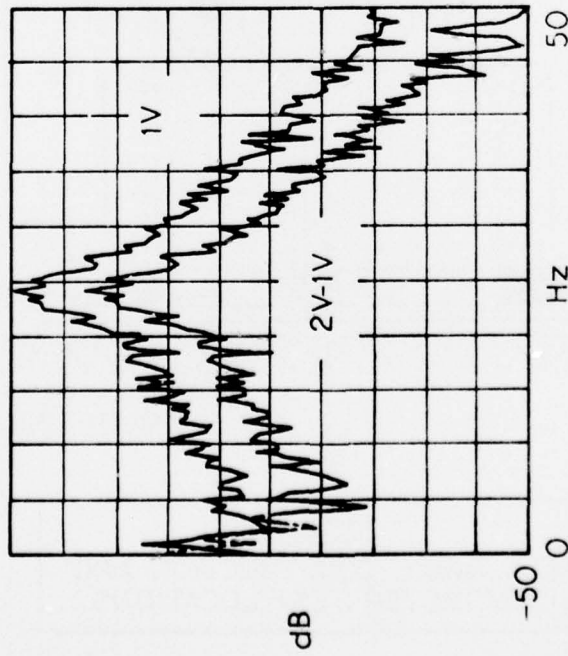

FIG. 5b: HORIZONTAL  
0.0002 dB ref.

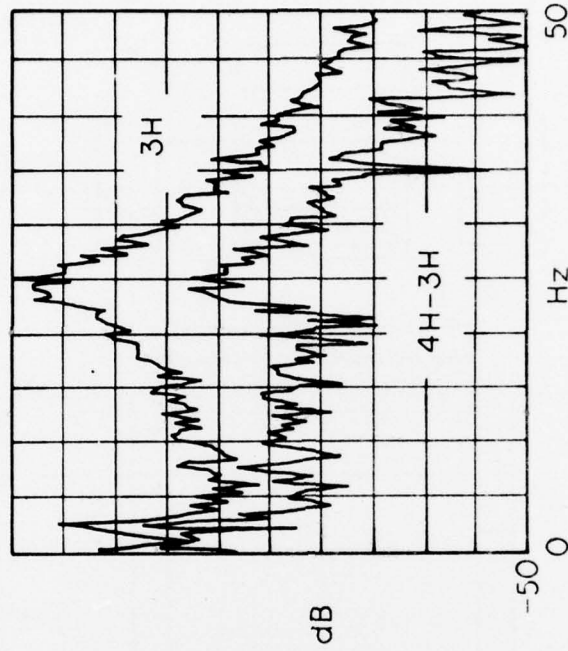
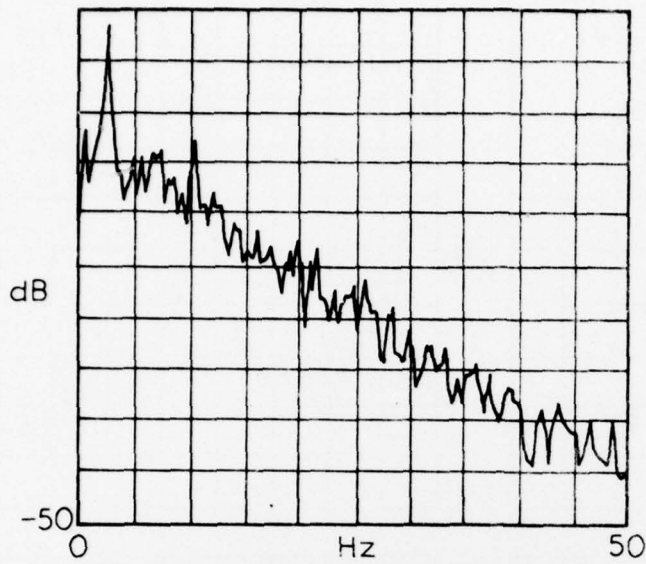
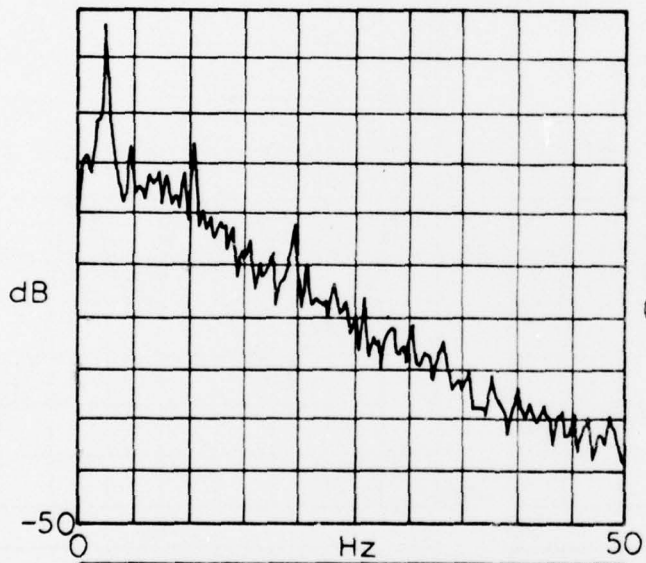

FIGURE 5  
PSM CHANNEL MATCHING



6a.  
VERTICAL  
(0.001 dB ref.)



6b.  
HORIZONTAL  
(0.001 dB ref.)

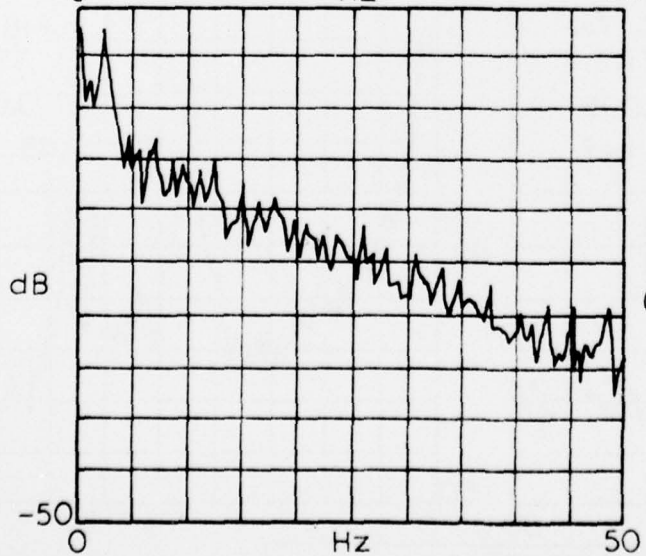

6c.  
ROTATIONAL  
(0.0005 dB ref.)

FIGURE 6  
PAD (REFERENCE)  
SEISMOMETER SIGNALS



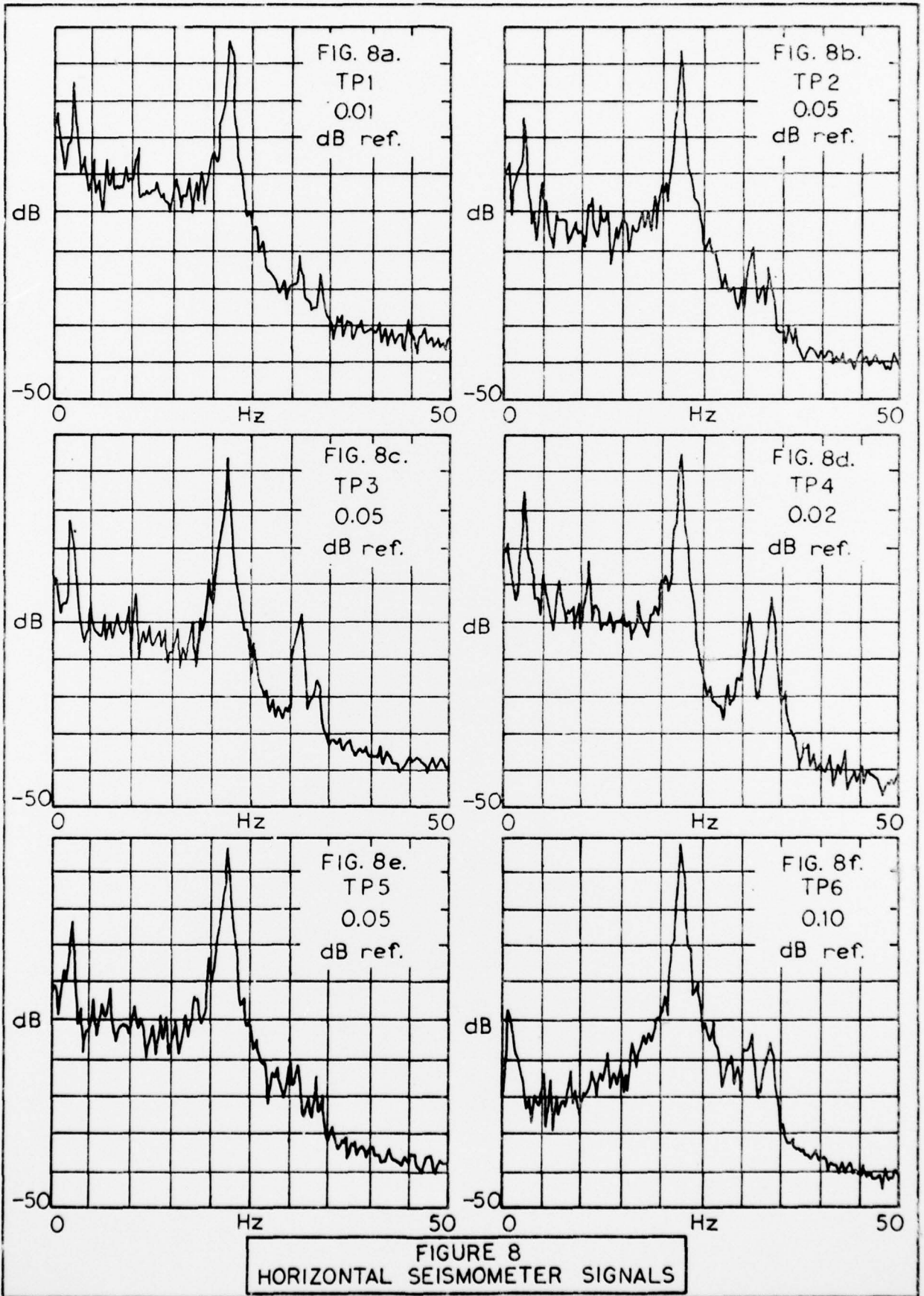

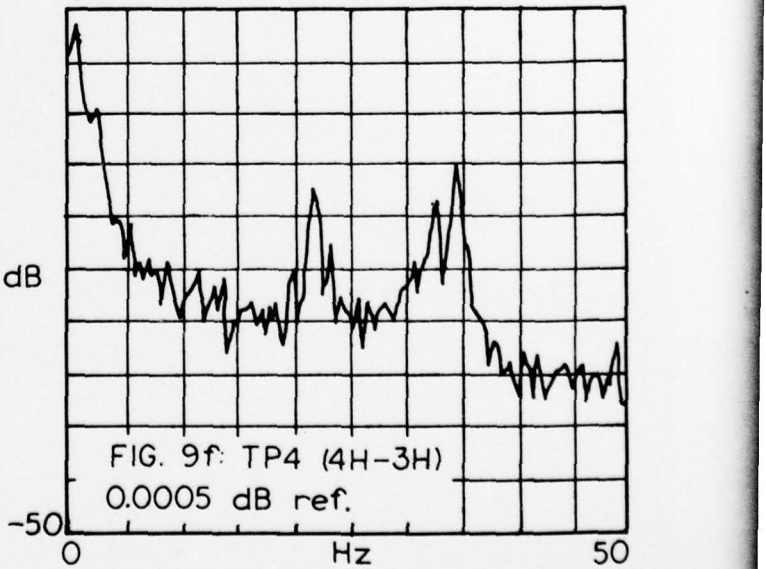
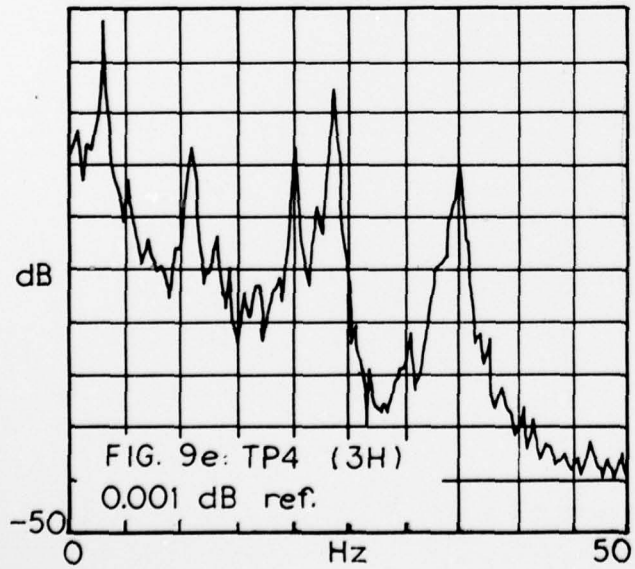
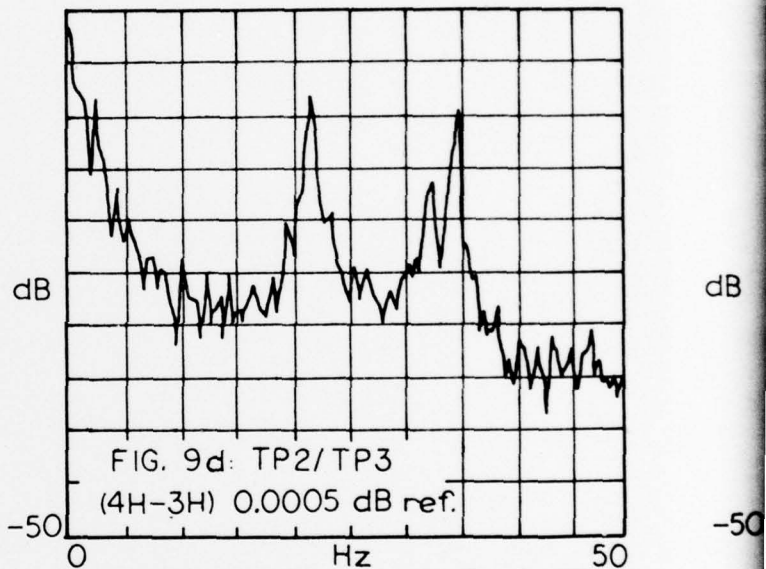
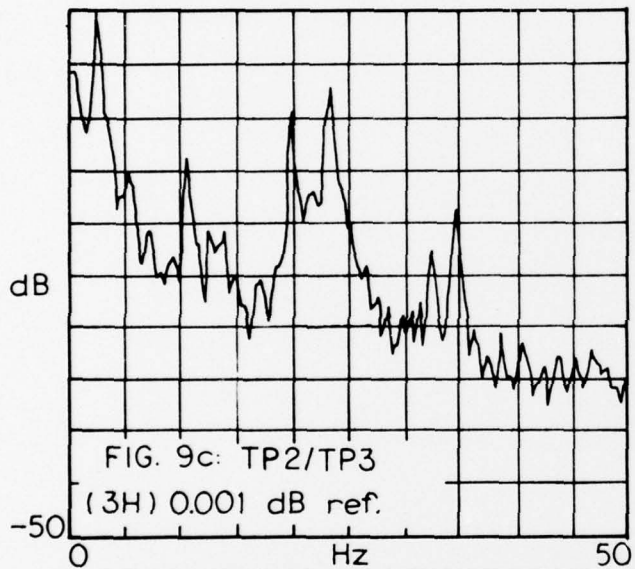
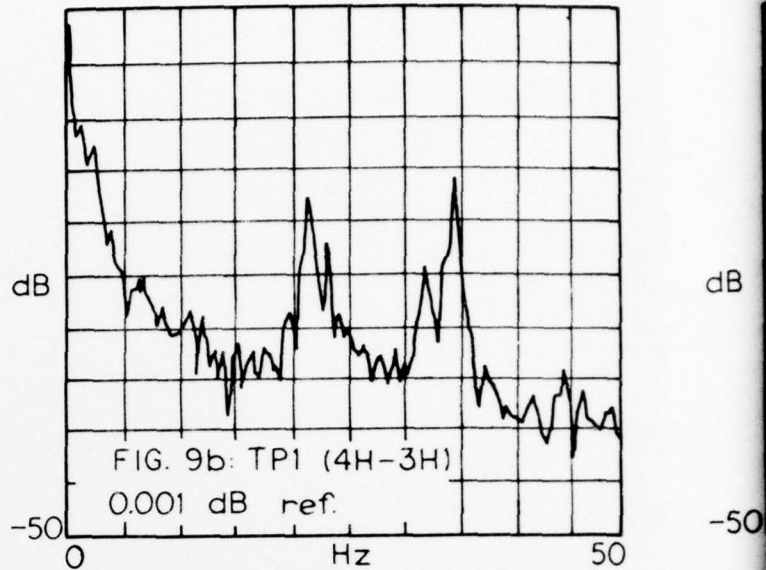
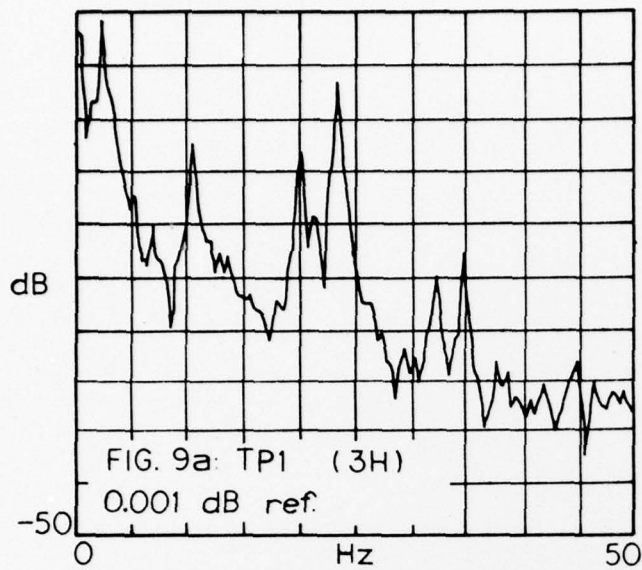

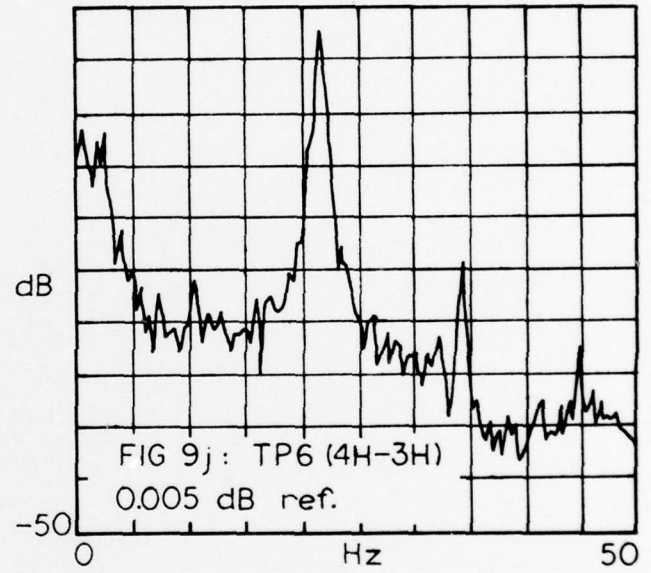
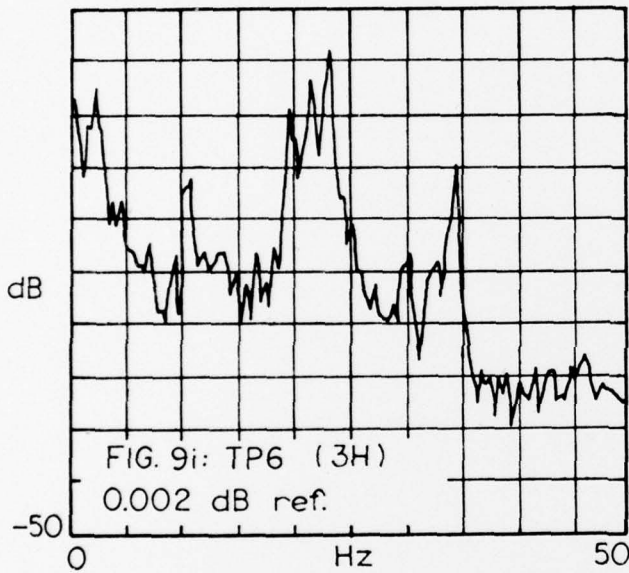
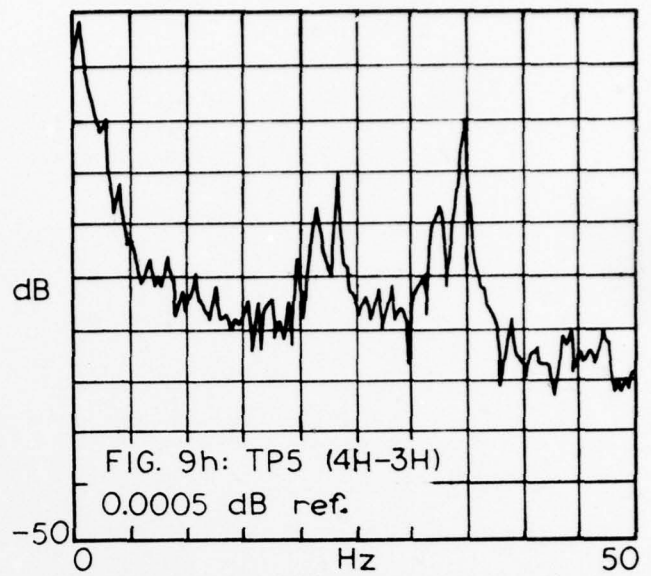
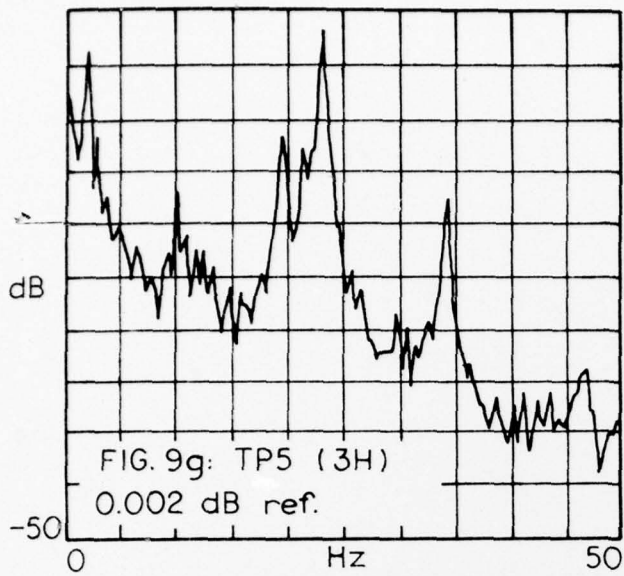

FIGURE 9  
ROTATIONAL SEISMOMETER SIGNALS

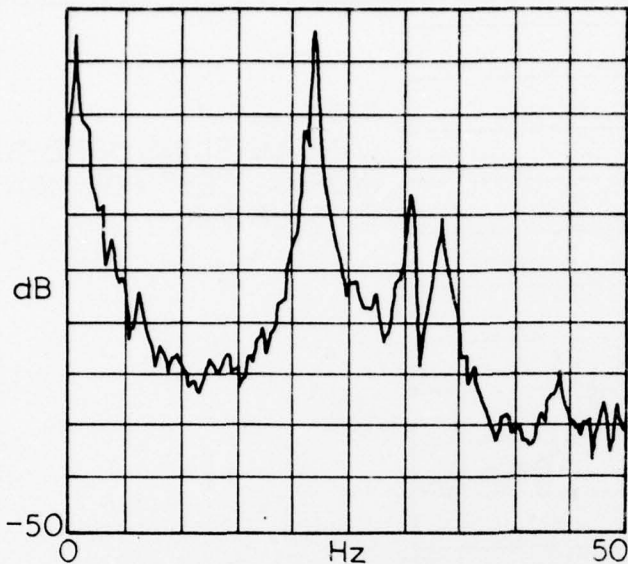

FIG. 10a.  
LONG LEVELING SCREWS  
(NORMAL TEST POSITION)  
0.005 dB ref.

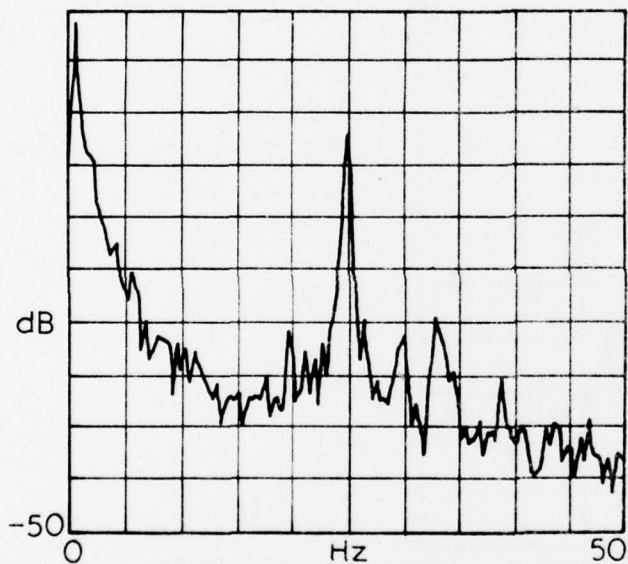

FIG. 10b.  
SHORT LEVELING SCREWS  
0.005 dB ref.

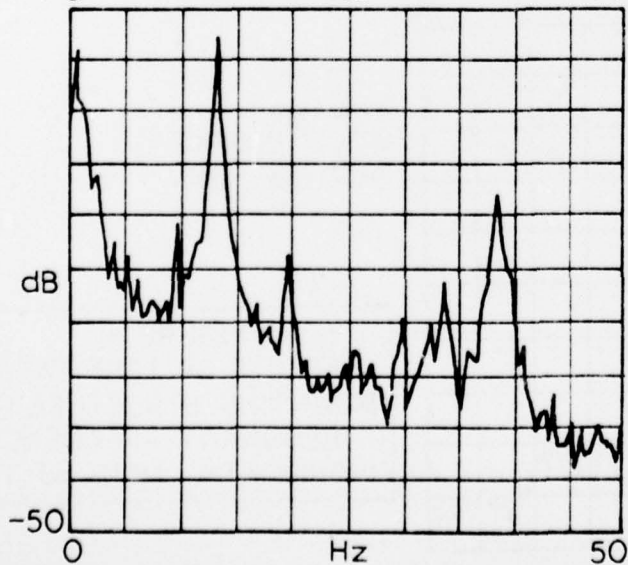

FIG. 10c.  
WOOD BLOCKS  
0.005 dB ref.

FIGURE 10  
EFFECTS OF TEST TABLE  
MOUNTING STRUCTURE ON  
RESONANT FREQUENCY  
(VERTICAL MODE AT TP5)

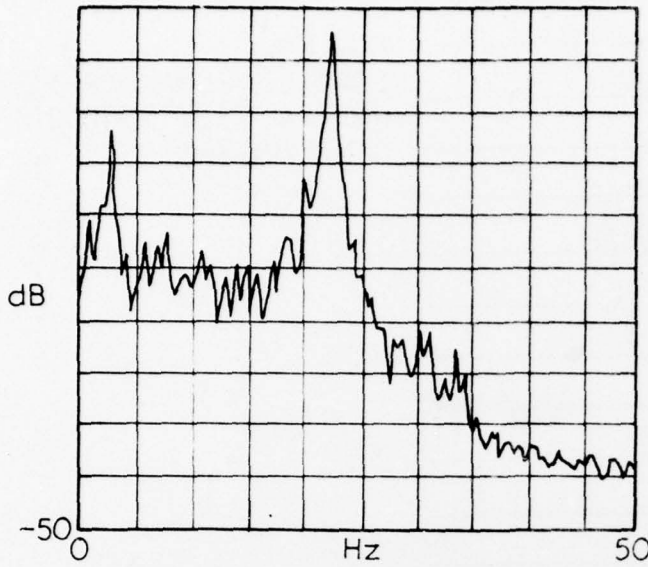

FIG. 11a.  
LONG LEVELING SCREWS  
(NORMAL TEST POSITION)  
0.05 dB ref.

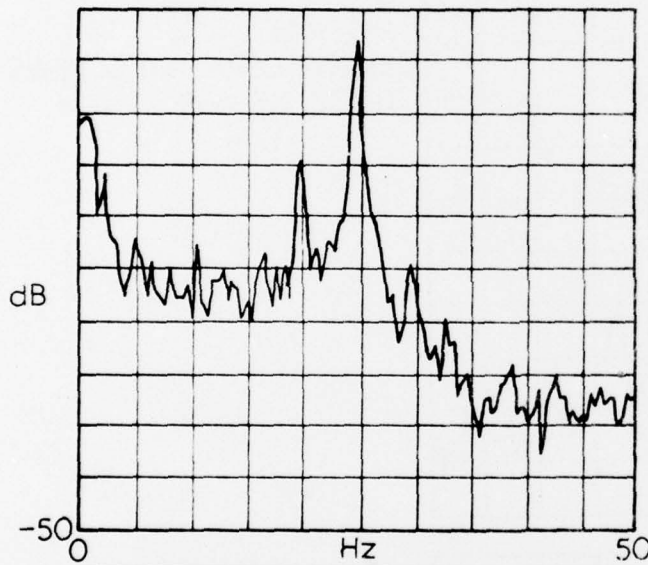

FIG. 11b.  
SHORT LEVELING SCREWS  
0.002 dB ref.

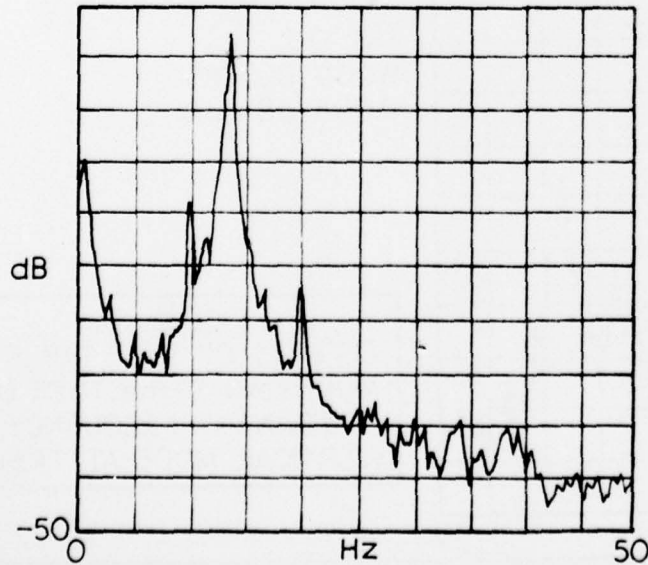
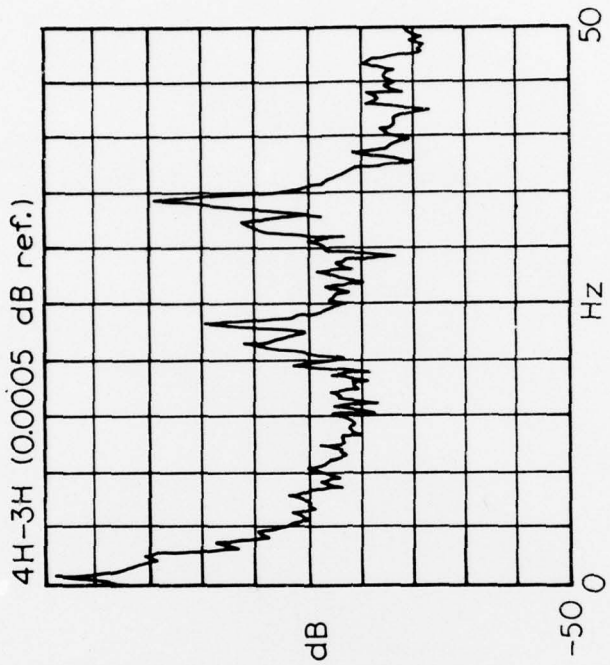
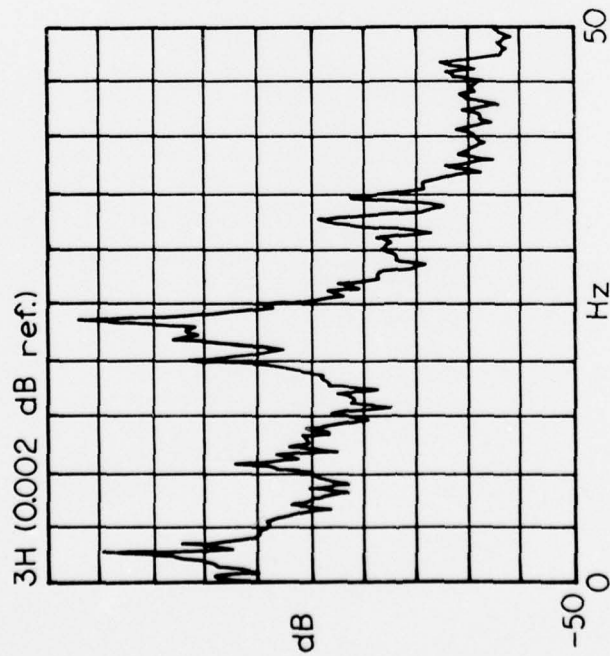

FIG. 11c.  
WOOD BLOCKS  
0.02 dB ref.

FIGURE 11  
EFFECTS OF TEST TABLE  
MOUNTING STRUCTURE ON  
RESONANT FREQUENCY  
(HORIZONTAL MODE AT TP5)

FIGS. 12a,b: LONG LEVELING SCREWS (NORMAL TEST POSITION)



FIGS. 12c,d: SHORT LEVELING SCREWS

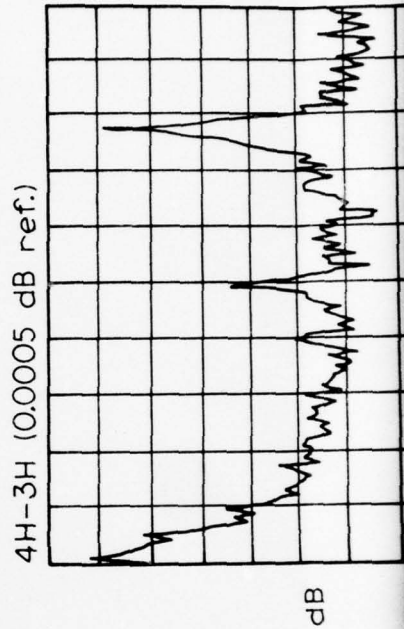
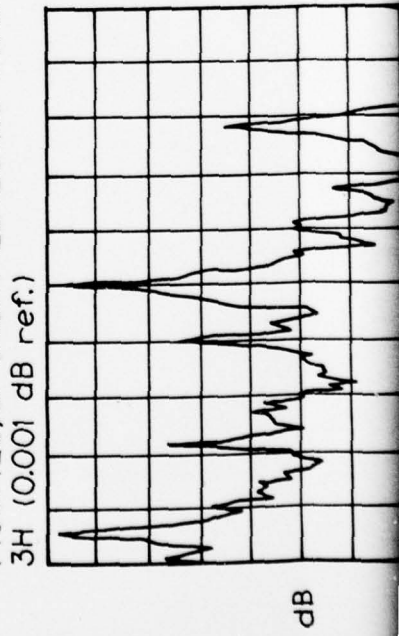

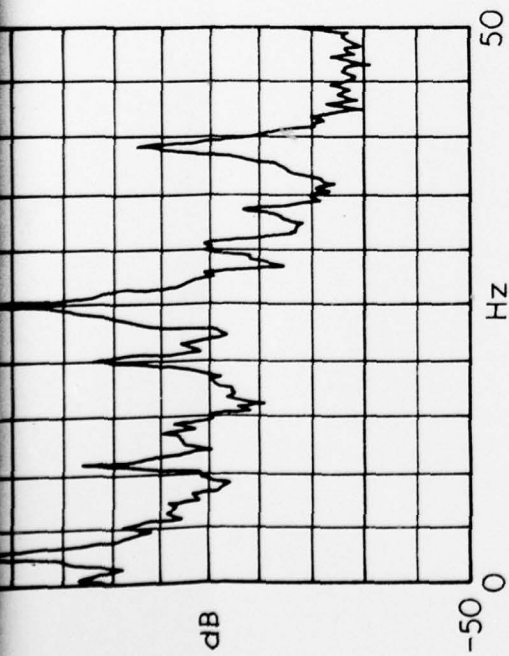

FIGS. 12e,f: WOOD BLOCKS  
3H (0.01 dB ref.)

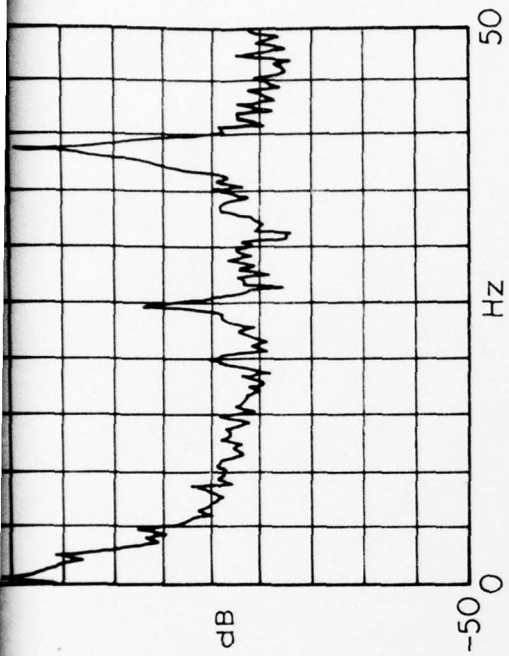
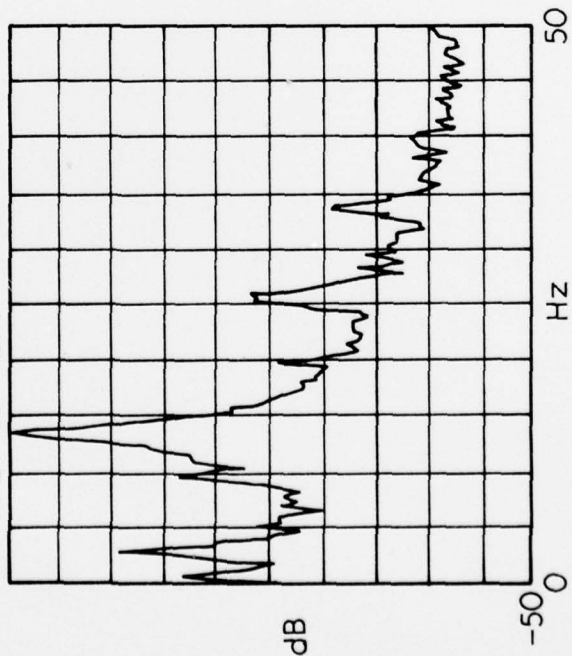

4H-3H (0.0005 dB ref.)

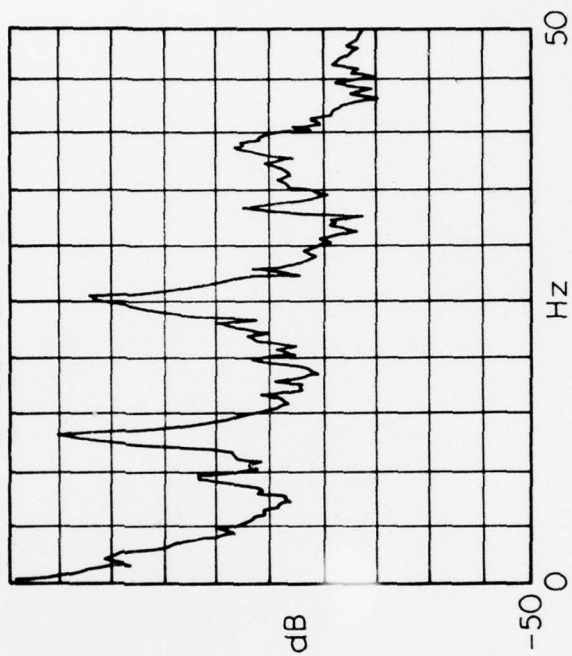

FIGURE 12  
EFFECTS OF TEST TABLE MOUNTING STRUCTURE  
ON RESONANT FREQUENCY  
(ROTATIONAL MODE AT TP5)