

AD-A044 943

COLD REGIONS RESEARCH AND ENGINEERING LAB HANOVER N H  
LOCK WALL DEICING STUDIES.(U)

F/G 13/13

UNCLASSIFIED

AUG 77 B HANAMOTO  
CRREL-SR-77-22

NL

| OF |  
AD  
A044943



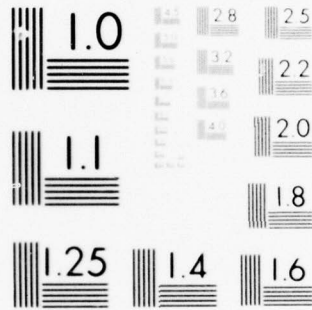

MICROCOPY RESOLUTION TEST CHART  
NATIONAL BUREAU OF STANDARDS-1963-A

14 CRREL-  
SR-77-22



AD A 044943

6

LOCK WALL DEICING STUDIES.

10

Ben/Hanamoto Editor

9

Special Report, 77-22

12

11

August 1977

12 74p.

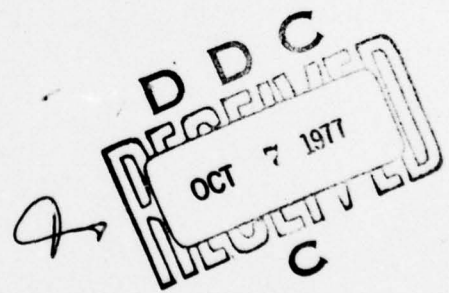

AD NO. —  
DDC FILE COPY

Prepared for  
DIRECTORATE OF CIVIL WORKS  
OFFICE, CHIEF OF ENGINEERS  
By  
CORPS OF ENGINEERS, U.S. ARMY  
COLD REGIONS RESEARCH AND ENGINEERING LABORATORY  
HANOVER, NEW HAMPSHIRE

1473  
037100

Approved for public release; distribution unlimited.

LB



## PREFACE

This report contains articles by several authors and was compiled and edited by Ben Hanamoto, Research General Engineer, Applied Research Branch, Experimental Engineering Division, U.S. Army Cold Regions Research and Engineering Laboratory (CRREL).

This study was performed under Civil Works Research and Investigation Program Ice Engineering, subprogram Ice Formation, CWIS 31334 - Preventing and Removing Ice from Adhering to Lock Walls and Gates.

The works contained in this report and their authors are:

Ice Removal from the Walls of Navigation Locks, by G. Frankenstein, Research Civil Engineer, CRREL; J.L. Wuebben, Research Hydraulics Engineer, CRREL; H.H.G. Jellinek, Professor, Department of Chemistry, Clarkson College, Potsdam, N.Y.; and R. Yokota, Research Associate, Department of Chemistry, Clarkson College, Potsdam, N.Y.

Development of Large Ice Saws, by D.E. Garfield, Research Mechanical Engineer, CRREL; B. Hanamoto (see above); and Dr. M. Mellor, Physical Scientist, CRREL.

Lock Wall De-Icing with High Velocity Water Jet at Soo Locks, Michigan, by D.J. Calkins, Research Hydraulics Engineer, CRREL; Dr. M. Mellor (see above); and H.T. Ueda, Mechanical Engineer, CRREL.

Laboratory Experiments on Lockwall Deicing using Pneumatic Devices, by K. Itagaki, Research Physicist, CRREL; M. Frank, Physical Science Technician, CRREL; and S.F. Ackley, Research Physicist, CRREL.

**The contents of this report are not to be used for advertising or promotional purposes. Citation of brand names does not constitute an official endorsement or approval of the use of such commercial products.**

CONTENTS

	Page
Preface. . . . .	ii
Summary. . . . .	iv
Introduction . . . . .	1
Lock wall deicing (B. Hanamoto). . . . .	7
Ice removal from the walls of navigation locks (G. Frankenstein, J. Wuebben, H.H.G. Jellinek and R. Yakota) . . . . .	15
Lock wall de-icing with high velocity water jet at Soo Locks, MI. (D. Calkins, M. Mellor and H. Ueda). . . . .	23
Development of large ice saws (D.E. Garfield, B. Hanamoto and M. Mellor) . . . . .	37
Laboratory experiments on lock wall deicing using pneumatic devices (K. Itagaki, M. Frank and S.F. Ackley) . . . . .	53

APPROVED for	
	<input checked="" type="checkbox"/> A Section <input type="checkbox"/> B Section <input type="checkbox"/> C Section
DISTRIBUTION/AVAILABILITY CODES OF CIAL	
A	

## SUMMARY

Proposed methods for the removal of ice buildup on lock walls included: embedded electrical heater lines, hot fluids, mechanical deicing boots, tractor-mounted chainsaws, backhoes, tractor-mounted trenchers, high-pressure water jets, and chemical surface coatings. Five of the methods considered promising have been studied: electrically heated panels, pneumatic boots, high-pressure water jets, mechanical chainsaws and chemical coatings. Heated panels and an inflatable boot were able to remove the ice from the walls, but because of high initial costs and problems that would be encountered during installation on lock-walls, studies on these systems have not been pursued. The high-pressure water jet system requires a high initial equipment cost. Improvements in nozzle design of the system tested could make it a usable deicing system. Further laboratory studies on nozzle design will be conducted.

On the two systems that have proven most promising, the mechanical chainsaw and the chemical coating, further field studies are being conducted. The mechanical cutting system, a coal-cutting chain-type saw, satisfactorily removed the ice collar formed on the lock walls. With modifications to the prototype, this system will be an operational unit. The chemical coating of the walls to facilitate the removal of ice has also proven quite promising. Coating of cleaned concrete walls, as well as epoxy undercoated sections of the wall, with a copolymer compound reduced the time and effort required for steam removal of the ice more than threefold. An underwater curable epoxy with a top coating

of the copolymer has so far proven very effective, even preventing the formation of ice on the wall, at least during the early winter season when ice problems are just beginning to occur. Further field tests are planned for a more thorough evaluation.

LOCKWALL DEICING STUDIES  
Edited by B. Hanamoto

INTRODUCTION

Navigation on the Great Lakes - St. Lawrence Seaway System has been traditionally suspended each winter between mid December and early April. The three- to four-month interruption is weather dependent and adverse winter conditions and the effects of ice are the primary reasons for the shutdown. Investigations for an extension of the navigation season have been authorized and studies have been conducted on the potential benefits of an extension and on the problems which must be overcome to make such an extension possible\*.

The Great Lakes - St. Lawrence Seaway extends from the western end of Lake Superior in Minnesota and Wisconsin to the Gulf of St. Lawrence on the Atlantic Ocean. Ships traveling the inland seaway route are lifted 183 m (600 ft) between the Atlantic Ocean and Lake Superior through a system of canals and locks. Seven seaway locks in the St. Lawrence River between the ocean and Lake Ontario, eight Welland Canal Locks between Lake Ontario and Lake Erie, and the Soo Locks at the St. Marys Falls Canal between Lake Huron and Lake Superior make up the canal and lock system on the seaway. Presently there are 59 commercial harbors on the Great Lakes with 15 additional private deep draft harbors in the Great Lakes Seaway System.

---

\*Great Lakes - St. Lawrence Seaway Navigation Season Extension, Feasibility Study (Draft), U.S. Army Engineer District Detroit, Corps of Engineers, Detroit, Michigan, July 1976.

Some of the benefits of an extended navigation season utilizing the Canal and Lock System and the available harbors include reduction in unit transportation costs, reduction in stockpiling costs, savings in energy consumption, development of new traffic and benefits of increased labor employment and earnings. The extension of the shipping season will eliminate service discontinuity for shippers using the seaway, thus avoiding the need to find alternate routes for the winter months. Savings will be realized with the less expensive water transportation which will be available to them for a longer period. The extension will also provide for more efficient use of shore terminals, harbors and ships.

Savings will also be realized with the reduction in annual freight rates by the more efficient utilization of the carrier fleet for a greater return on capital investment in ships. Stockpiling savings can be gained by reduction in capital invested in the stockpile inventory, by stockpiling real estate being eliminated or putting it to more productive use, and by reduction in managing and handling incurred in stockpiling. Savings in energy consumption will also result by making maximum use of fuel in transporting the vast volume of bulk commodities and cargoes.

The savings can be visualized with the following comparative figures. The average bulk carrier on the Great Lakes operates at about 500 ton-miles per gallon of fuel. Other carriers operate at about 200 ton-miles per gallon for rail, 58 ton-miles per gallon for trucks and less than 4 ton-miles per gallon for air transport. Finally, the season extension

will result in increased labor employment with more jobs and greater earnings for the labor force. It will also aid in developing new regional traffic and business which will directly contribute to area development.

Negative effects of an extended navigation season on the inland waterway include the diversion of future expected traffic away from the rail and trucking industries. It would also divert traffic away from the Eastern and Gulf ports toward the Great Lakes - St. Lawrence Seaway System. Two other areas of concern are: possible negative benefits on power production along the Great Lakes waterway and effects on winter recreational use of the waterways.

The implementing of the extension of the inland seaway shipping season will create problems in water navigation as well as in associated areas. Water navigation in winter will primarily be concerned with ice in four water areas: channels, harbors, locks and open lakes. The ice-related problems fall into four main categories: ice information, ice navigation, ice control, and a general category including all associated problems arising from an extended shipping season. Problem areas in ice information include: winter weather reporting and forecasting, forecasting techniques for ice information and growth and freezeup and breakup on the waterways, reconnaissance with specially equipped aircraft for ice cover and extent information and the monitoring of ice conditions by physical measurements.

The ice navigation problem area includes: means of keeping shipping lanes open, requirements for vessel modification for winter operation,

additional navigational aids (buoys), precise navigation systems, and requirements for channel modifications. In the ice control problem area, investigations may be required on: ice booms, air bubbler systems to reduce or retard ice formation and growth, other means to prevent ice formation, means to facilitate icebreaking and controlling of ice at the canal lock facilities at such places as the gates, along the walls and in the entrance and exit channels.

In the associated problem areas affected by winter navigation, the concern will focus on: shore erosion and shore structure damage, ice jams and flooding, effects on personnel operating the vessels and manning the harbor facilities, safety and survival, effects on hydro-electric power generation, effects on water levels and flows, effects on winter recreation, legal and international aspects of winter navigation, public safety, welfare and health and the environmental effects of oil spills and waste disposal. It becomes evident that an extension of the navigation season on the Great Lakes - St. Lawrence Seaway System will involve problem solutions in many disciplines, including economics and engineering, and will have environmental and social impacts on the entire 19-state Great Lakes Region, the region along, as well as bordering on the Waterway System.

The study to investigate the feasibility of extending the navigation season is being conducted under the Demonstration Program portion of the winter navigation study authorized by Congress in 1970. The

studies being conducted by the U.S. Army Cold Regions Research and Engineering Laboratory are in the ice control areas. The investigation of means to keep the lockwalls free of ice build-up is one of the study tasks and the following papers present the results of the studies conducted to date.

## LOCK WALL DEICING

Ben Hanamoto

The U.S. Army Cold Regions Research and Engineering Laboratory (USACRREL) has been studying various methods to optimize the removal of ice adhering to lock walls. The effort has been concentrated on the Poe Lock, Sault Ste. Marie, Michigan, which is the widest of the Soo Locks, but only 1.5 m (5 ft) wider than the maximum beam of some of the ore ships which make use of it.



Figure 1. The Roger Blough with its 32 m (105 ft) beam entering the 33.5 m (110 ft) Poe Lock.

The build-up of ice on the lock walls is formed by a combination of two major processes. Ships down-bound through the locks push ice from the lake into the locks and crush it outward against the wall. Then,

PRECEDING PAGE BLANK-NOT FILMED



Figure 2. Presque Isle, 32 m (105 ft) beam.

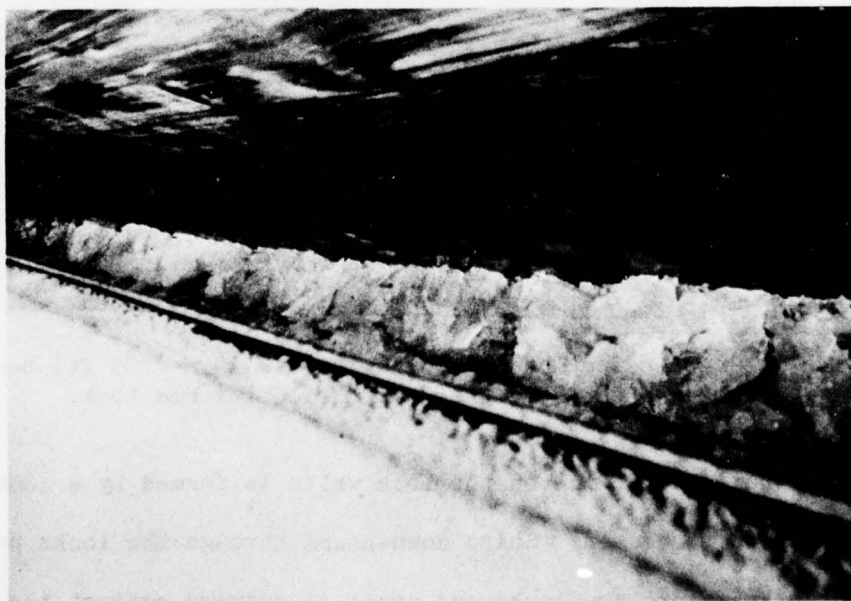

Figure 3. Ice crushed against lock wall by side of the ship.

when water in the lock lowers, this crushed ice forms a solid mass (often termed an ice collar) which becomes firmly frozen to the wall. The exposed wall temperature is approximately the same as the ambient temperature, which greatly assists the freezing process. This ice must either

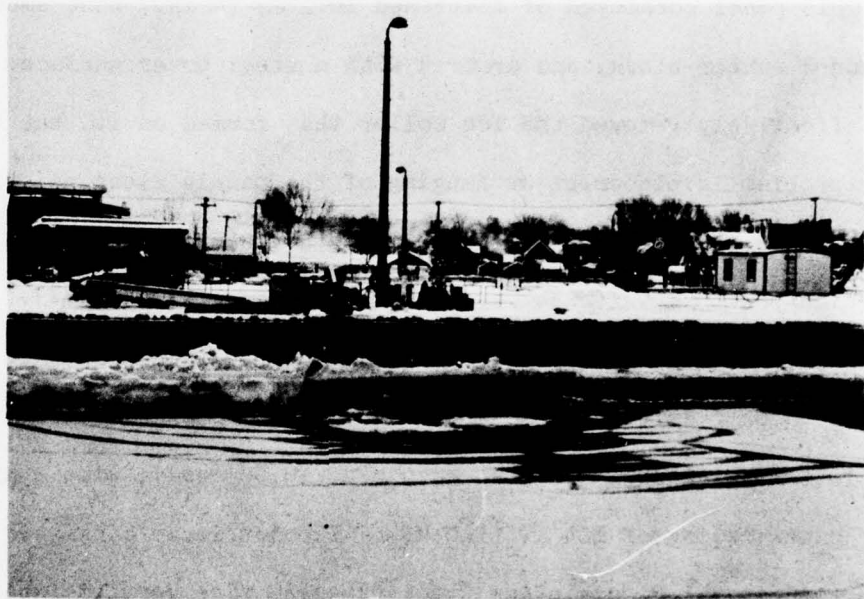

Figure 4. South Wall, Poe Lock, ice collar depth about 1.8 m (6 ft).

be prevented from freezing on the wall, or removed after freezing. If no action is taken, ice will accumulate and eventually prevent the passage of ships through the locks.

The work in FY75 was concentrated on two deicing systems, an inflatable boot and a high-pressure water jet. Inflatable devices had been successful on radomes for removing ice; thus this method was examined. Preliminary laboratory tests with models were conducted to evaluate several pneumatic inflatable devices. A promising design consisted of

a section of fire hose as the inflatable portion, which was protected by an outer armored surface. Air forced into the hose caused expansion, which in turn moved the outer surface causing ice fracture. A large test panel was placed along a short section of the Poe Lock for evaluation. This panel consisted of flattened 10.1 cm (4 in.) hose embedded in a poured rubber block, and armored with a steel outer surface. The system effectively removed the ice collar that formed on it, but the primary problem is placement or hanging of the panels along existing walls. A more detailed report on pneumatic devices is presented later.

A high-pressure water jet system was also examined in FY75. The high-pressure source was a truck-mounted industrial cleaning unit, consisting of a pump driven by a diesel engine. The pump was rated to give  $1.51 \times 10^{-3} \text{ m}^3/\text{s}$  (24 gpm U.S.) at 68.9 MPa (10,000 psi), with a hydraulic power rating of 104 KW (140 HP). The jet lance consisted of a 1.27 cm (1/2 in.) I.D. stainless steel pressure pipe carried inside a 5.08 cm (2 in.) steel pipe. At the lower end was a nozzle block to which a range of nozzles could be attached. The exit diameters of the nozzles varied from 0.22 to 0.39 cm (0.086 to 0.152 in.). The jet lance was carried on a rubber-tired tractor which had hydraulic drive for low crawl speeds, and a hydraulic lift for manipulating the lance mount. The tests demonstrated that a water-jet operating in the region of 68.9 MPa (10,000 psi) is capable of cleaning ice from a lock wall without damaging the wall itself. The power level of this unit was not enough for positive cutting of deep ice collars 2.44 m (8 ft) at

operationally acceptable traverse speeds of 1.83 m/min (6 ft/min). At useful traverse speeds, 1.22 m (4 ft) of solid ice was penetrated, and ice depths of 0.61 m (2 ft) were penetrated at quite attractive speeds of nearly 2.44 m/min (8 ft/min).

Three methods of ice removal were tested during FY76. These included a chemical coating of the concrete walls to reduce the adhesion forces between the wall and the growing ice collar, a high-pressure water jet, and a mechanical cutting system to remove the ice collar.

The high-pressure water-jet equipment included a self-propelled, heated trailer, which housed the high-pressure pump and associated mechanical and electrical equipment (Fig. 5). A separate 200 KW generator

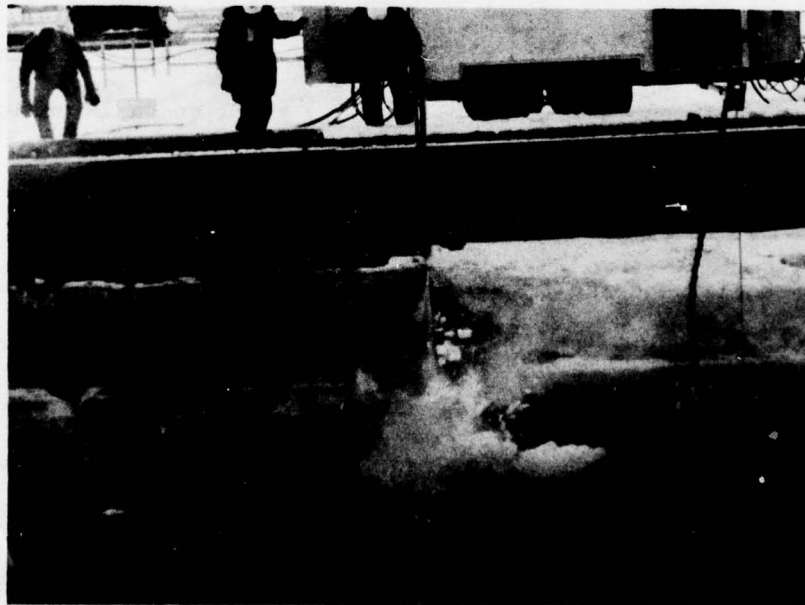

Figure 5. High pressure water jet.

provided electrical power for all the equipment. Jet cutting could be accomplished by either suspending the jet from the side of the moving trailer, or by leaving the trailer stationary and manually moving the jet. This flexibility was to allow ice-cutting operations around gates and other areas not accessible to mechanical cutting equipment. Approximately  $1.2 \times 10^{-3} \text{ m}^3/\text{s}$  (20 gpm) of water was pumped from the lock, filtered, and pressurized to between 68.9 and 96.5 MPa (10,000 and 14,000 psi). Several sizes and types of jet nozzles were tested. Penetrations of up to 0.91 (3 ft) were obtained at slow traverse rates of under 0.61 m/min (2 ft/min). A detailed report on water jets is presented in this report.

The concept for mechanical cutting was to use a bar and chainsaw moving parallel to the lock wall, cutting the ice to within a few inches of the ice/wall interface. Two types of saws were selected: a thin-kerf coal saw which cut a 8.76 cm (3-1/4 in.) kerf, and a large lumber-cutting chain saw which cut a 1.43 cm (9/16 in.) kerf. Both bars were about 4.57 m (15 ft) long and were cantilevered from the sides of small rubber-tired soil-trenching tractors (Figs. 6 and 7). The coal saw had replaceable hardened-steel teeth, provided generous capacity for removing cuttings, and had a relatively stiff bar. The lighter lumber saw required less power to operate; however, lack of adequate clearance for cutting removal and the bar flexibility created problems with the smaller machine. When cutting in ice 2.13 to 2.44 m (7 to 7 ft) thick, traverse rates of 1.98 m/min (6-1/2 ft/min) were attained with the coal

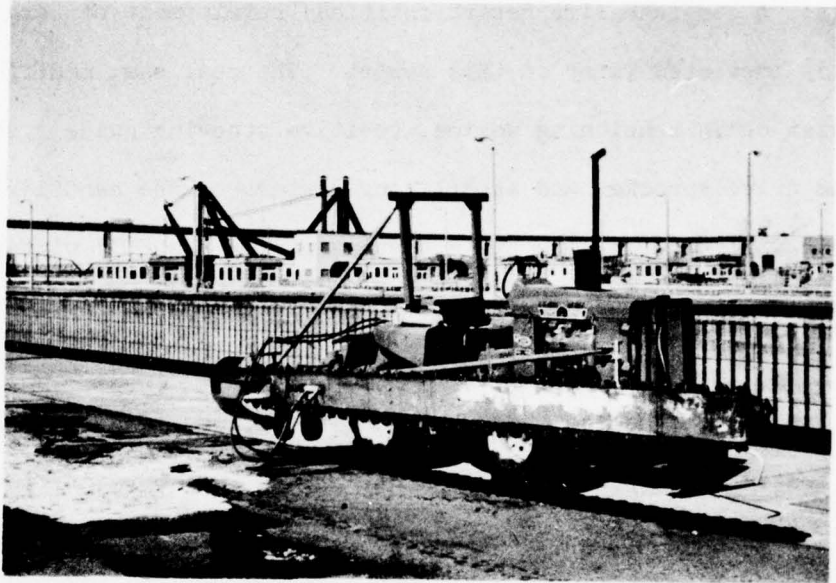

Figure 6. Coal saw cutting unit.



Figure 7. Lumber saw cutting unit.

saw unit. A comprehensive report entitled "Development of Large Ice Saws", is presented later in this report. The coal saw, modified with a sturdier chain tensioning device, positive steering guide system, improved drive sprocket and stabilizing casters on the cantilevered drive hub will undergo more field testing during the FY77 winter season.

The purpose of the chemical coating of the lock walls was to reduce the interfacial bonding force between the ice collar and the coated wall. Removal of the ice would be facilitated, or, ideally, ice formation on the coated walls would be prevented. Based on laboratory investigations, a promising compound consisting of co-polymers of polycarbonate and polysiloxane substantially reduced the ice adhesion forces. To evaluate various chemical coating compounds, short sections of the Poe Lock walls were coated. The walls were cleaned by sandblasting, by steam cleaning or by airblasting. Three coats of the co-polymer were sprayed on the wall where ice formation caused problems. An epoxy-resin compound was also tried, primarily to test its suitability as an undercoating. A paper describing the work on chemical coatings follows and is one of the four papers included in this report on deicing devices. Further work is being conducted with coatings, primarily with undercoatings which will provide a better surface than porous concrete for adhesion of the co-polymer coating. Portions of the lock walls at Sault Ste. Marie, Michigan, have been coated for FY77 winter season evaluation.

## ICE REMOVAL FROM THE WALLS OF NAVIGATION LOCKS\*

by G. Frankenstein, M.ASCE; J. Wuebben, A.M.ASCE;

H. H. G. Jellinek; R. Yokota

### DEVELOPMENT OF AN ICE-RELEASING COATING

The problems of ice adhesion encountered in practice are of quite a different nature than the fundamental problems studied in the laboratory. It is quite feasible to choose satisfactory substrates of sufficiently hydrophobic nature to diminish ice adhesion to an acceptable extent, but the main problem is that such substrates become contaminated after a few adhesions and become useless. Therefore, the problem was to find a suitable hydrophobic surface which renews itself during use and remains efficient for long periods of time. It was therefore decided to conduct a laboratory experiment with development of the best possible coating for ice release as its objective.

The coatings to be tested were those containing additives which accumulate in the coating/ice interface to sufficiently decrease adhesion or weaken the strength of the ice at the interface. The coating should also be self-mending: it should be replenished spontaneously by diffusion from the bulk of the coating as soon as the releasing materials at or near the interface is removed by ice adhesion.

Polymer coatings were selected for testing because their properties are somewhat hydrophobic, allowing additives to diffuse to the surface. A polymer may also have some polarity so that it can retain a sufficient reservoir for an appreciable number of ice adhesions.

---

\*Presented at ASCE Conference, "Rivers 76," Fort Collins, Colorado, June 1976

The polymer coatings with additives were applied to aluminum plates (7.5 cm x 7.5 cm). The plates were first cleaned with Alconox detergent, rinsed in tap water and distilled water, and then oven-dried at 85°C. Before coating, the cleaned plates were immersed in methylene chloride for 30 min. Two coats of the solution were then applied to the given plate.

Adhering the ice to the coated plate was accomplished in the following manner. An aluminum cylinder (diameter 4.3 cm) was placed upright on the prepared plate and cooled to -10°C. Boiling distilled water was then poured into the cylinder and again cooled to -10°C. The sample was stored at this temperature for 20 hours before testing.

The plate and cylinder were then placed in the test apparatus to measure the force required to separate the two. This was accomplished by clamping the cylinder and then pulling the coated plate smoothly in a horizontal direction. This pull was measured by a strain gauge calibrated in terms of force. Knowing the area, one could then calculate the so-called adhesive strength. The testing was accomplished at the stored sample temperature by constructing a cold chamber in which to place the test apparatus.

#### LABORATORY TEST RESULTS

The first test was conducted on eight plates that were cleaned as described above but not coated. The mean adhesive strength for these plates was 3.58 kg/cm<sup>2</sup> with a standard deviation of 0.668 kg/cm<sup>2</sup>. This was the value that the coated plates would be compared to.

Approximately 100 tests were made with various coatings. Coatings which gave low adhesion values were subjected to repeated adhesion tests. Tests were repeated by using one plate for each coating, drying it after each test without cleaning, and then refreezing the ice cylinder to it. Table I lists the results of these repeated tests.

TABLE I  
Repeated Adhesion Tests

<u>Sample</u>	<u>Force, kg/cm<sup>2</sup></u>						
	1	2	3	4	5	6	7
1	0.52	0.42	0.38	0.78	0.39	0.68	0.33
2	0.42	0.41	0.76	0.50	0.40	0.50	0.50
3	0.22	0.54	0.64	0.60	0.40	0.33	0.43
4	0.53	0.63	0.41	0.51	0.62		
5	0.45	0.43	0.36	0.50	0.37		
6	0.43	0.58	0.45	0.53	0.45		
7	0.64	0.52	0.30	0.36	0.51		

All seven samples were polycarbonate (Lexan) based coatings. Sample 1 had no additives, samples 2 through 7 contained block co-polymers and samples 5 through 7 also contained silicone oil.

Further testing indicated that the block co-polymer LR5630 (manufactured by General Electric, Inc.) plus 10% silicone oil, is the most effective coating for reducing the adhesive strength of ice. This combination corresponds to Sample 3 in Table I. All further testing was conducted with this compound.

Four aluminum plates coated with the above solution was placed at the bottom of a river for three days. When retrieved from the river bottom, they were covered with sand. Two of the plates were rinsed before testing and two were untouched. The results were about the same in both cases and did not differ significantly from those of corresponding tests which did not include exposure in the river.

In the next series of tests, similar-sized plates of concrete were coated with the solution. Although this phase of testing is not yet complete, preliminary results indicated that the coating was suitable for field tests.

#### FIELD TESTING PROGRAM

In order to examine the practicability of the laboratory findings, the most promising coating developed in the laboratory was employed in a large-scale field test. This coating consisted of the block co-polymer of polycarbonate and dimethylsiloxane LR5630 (General Electric, Inc., designation), with 10% silicone oil added by weight. The solvent used for application consisted of 90% toluene and 10% methylisobutylketone on a volumetric basis. This mixture had been found to reduce ice adhesion to metal and concrete by over 97% under laboratory test conditions. It also had the desirable characteristic of being a clear, easily-applied material with sufficient pot life for preparation several days before use.

The south wall of the Poe Lock at Sault Ste. Marie, Michigan, was chosen as the test site. The Poe Lock is the largest of the four St. Marys River locks and is the only one normally used during the winter navigation

season. The north wall of the lock is exposed to the sun and remains relatively ice-free, but the unexposed south wall has been known to accumulate ice up to 4 ft thick.

The coating was applied to 176 x 9-ft section of the wall. Depending on lock operating procedures, an ice collar would normally form within this 9-ft range. Within this test section, the polymer coating was applied under three distinct conditions. The first 22 ft of wall had been treated two years previously with epoxy paint (530A Coroline Primer and 709A Coroline Topcoat) manufactured by the Cielcote Company of Berea, Ohio. This area and the next 66 ft of untreated concrete were first steam-cleaned and then dried with high-pressure air. Figure 1 shows the condition of the lock wall before cleaning. The epoxy-coated section is on the left and the natural concrete is on the right. It can also be seen that, unlike the laboratory test surfaces, the surface encountered in the field was rough, porous and covered with both organic and inorganic deposits. Figure 2 shows the contrast between wall conditions before and after steam-cleaning. The remainder of the test section was cleaned only by the high-pressure air which removed little more than loose scale and organic growths.

Three coats of the polymer were then applied at a rate of  $5.8 \text{ l/m}^2$  ( $238 \text{ gal/ft}^2$ ) for each layer by using an airless spray gun. As shown in Figure 3, it was not possible to keep the concrete surface completely dry since the porous concrete retained some moisture, and cracks within or between the concrete monoliths allowed water to seep onto the working surface. In addition, there were intermittent periods of light rain during application, and the test section was submerged when the lock needed to be operated only 6 hours after completion of the coating application.

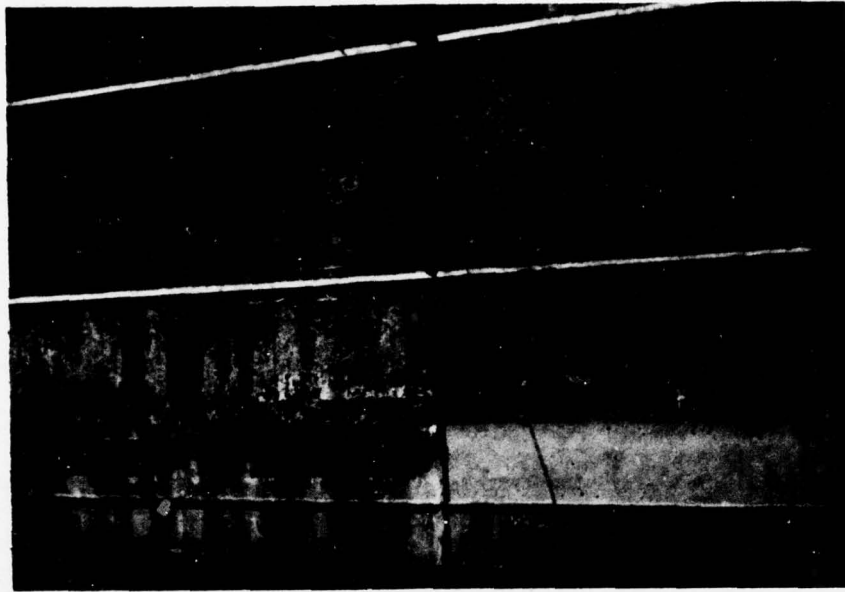

Fig. 1. Lock wall before cleaning

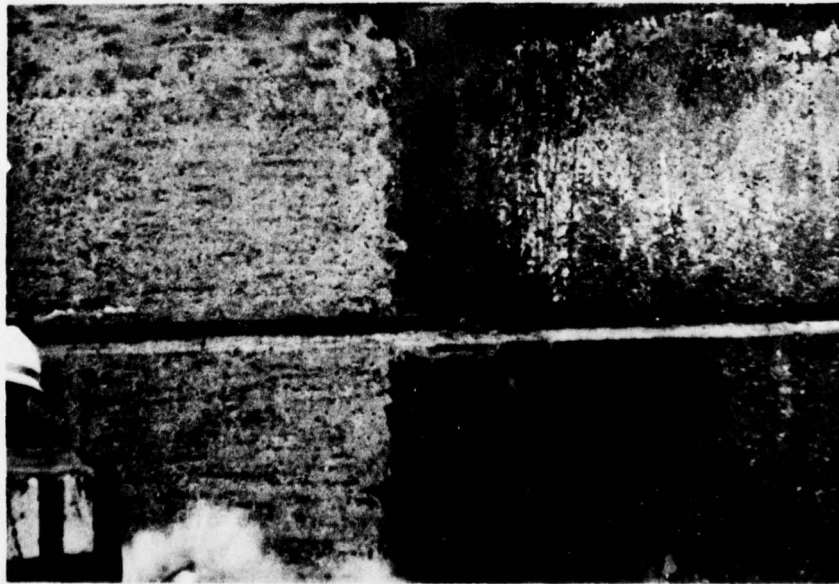

Fig. 2. Lock wall after cleaning



Fig. 3. Applying coating to the lock wall

#### FIELD TEST RESULTS

The effectiveness of the wall coating was demonstrated by the ease with which the ice collar could be removed. Ice formation was not prevented but removal by heat application was significantly facilitated. Steam spreader bars placed on the ice collar required from 4 to 6 hours to remove ice equal in length to the bar on an uncoated section. On the coated wall, a section equal to the steam spreader bar length plus an additional 20 ft of ice collar was removed in less than 1/2 hour. Mechanical action of the coal saw, when working in the coated section, caused 24 ft of the ice collar to fall off. No ice fell in the area that was not steam-cleaned. The ice that fell off using the steam spreader was in the area that

was steam-cleaned but contained no epoxy undercoating. The area where the saw operated contained the epoxy plus our coating.

Based on these tests, a coating of the lock walls with the co-polymer compound used in conjunction with either a heat or mechanical system should reduce considerably the effort required for lock wall ice removal.

#### ACKNOWLEDGEMENTS

The authors would like to thank the personnel at the Soo Locks, especially R. Izzard and R. Wiinamaki, for their assistance in conducting the coating tests. The authors also appreciate the cooperation received from B. Hanamoto and H. Ueda of CRREL.

## LOCK WALL DE-ICING WITH HIGH VELOCITY WATER JET AT SOO LOCKS, MI.\*

by D. Calkins, M. Mellor, H. Ueda

### Introduction

The lock wall de-icing project conducted in 1976 by the USACRREL Ice Engineering Program included further investigations into the use of a high velocity water jet to remove the ice collar which forms on the lock wall. Previous investigations concerning the feasibility of the method had been made by Mellor (1974) and by CRREL-NRC\*\* during the 1974-75 season at St. Lambert Lock in Montreal and the Soo Locks at Sault Ste. Marie, MI (Brierley, 1975). A high pressure water pump and the necessary auxiliary equipment were purchased during the latter part of 1975. The system was housed in a mobile trailer and placed on the south wall of the Poe Lock at Sault Ste. Marie on 15 December 1975. Final assembly and testing were carried out from 21 January to 6 February 1976 and from 16-20 February 1976. This note describes the equipment and summarizes the testing.

### High Pressure Pumping System

The major component in the system is a Kobe, Size 4, triplex pump purchased from Kobe, Inc. of Huntington Park, CA. It is rated at 13,600 psi (93.8 MPa) at 18.9 gal/min ( $1.19 \times 10^{-3} \text{ m}^3/\text{sec}$ ) driven by a 150 HP (112 kW) electric motor. This unit can be converted to 30,000 psi (206.8 MPa) at 7.38 gal/min ( $.47 \times 10^{-3} \text{ m}^3/\text{sec}$ ) by changing the plungers and liners. Delivery time and potential future use within the laboratory predicated the selection of the electric motor drive. Approximate weight of the unit is 6700 lb. (29.8 kN).

\* USACRREL Technical Note, June 1976.

\*\* National Research Council, Ottawa, Canada

Plumbing hardware consists mainly of Autoclave Engineers "AE Slim Line", coned and threaded fittings with ratings up to 20,000 psi (137.9 MPa). These are used in combination with conventional NPTF pipe fittings. The coned and threaded fittings provide the convenience of a union coupling and are better suited for repeated joint assembly and disassembly.

High pressure hose from Anchor Coupling Co. is used for conveying the fluid. They are flexible, 1/2 inch (50.8 mm) i.d. hose reinforced with six spiral wraps of steel wire and rated at 7500 psi (5.17 MPa) working pressure. It was necessary to use this size of hose, despite its lower than desired working pressure rating, in order to keep the flow pressure losses to a tolerable level. The hydraulic industry does not have available, as yet, the larger hose sizes with suitable pressure ratings.

The inlet water to the high pressure pump is supplied by a Reda submergible pump. This is a conventional deep well unit rated at 20 gal/min ( $1.26 \times 10^{-3} \text{ m}^3/\text{sec}$ ) at a 150 ft (45.7 m) head and driven by a 1 HP (746 W) electric motor. The pump is lowered into the lock from a boom extending beyond the lock wall. Water is transported through a 1-1/4 inch (32 mm) i.d. flexible hose and through a 25 micron Cuno filter before entering the high pressure pump. A minimum inlet pressure of 40 psi (276 kPa) is maintained at the inlet to the high pressure pump.

The difficulty encountered in lowering and raising the 80 lb (355 N) submergible pump into the lock water prompted a change during the later trial period. A Homelite, gasoline engine driven pump was tried. This unit had a rating of 72 gal/min ( $4.54 \times 10^{-3} \text{ m}^3/\text{sec}$ ) at 145 ft (44.2 m)

head and a high suction capability. This would have necessitated lowering only the inlet hose into the water. The unit performed satisfactorily at the higher water levels but the low water level proved to be slightly more than the pump could draw.

A third pump is employed to circulate an anti-freeze solution through the entire system immediately after shutdown to prevent freeze-up.

The entire system, less generator, is mounted on a steel framed, tandem wheeled, five ton trailer, 7 ft (2.13 m) wide by 11 ft (3.35 m) long fabricated at CRREL. An insulated aluminum enclosure was fabricated by E. Labrie of Nashua, NH. The enclosure is removeable to facilitate the installation of components (Fig. 1). A hydraulically powered drive wheel is mounted on the front tongue of the trailer to provide mobility. An articulated boom is mounted on the rear corner of the trailer to hold and position the high pressure jet assembly (Fig. 2). A hydraulic control permits vertical positioning of the jet while a mechanical linkage and a spring keep the jet tight against the lock wall.

A 200 kW electric, diesel driven generator to operate the 150 HP (112 kW) pump was rented from Malette Construction Equipment Company of Sault Ste. Marie, MI. This was a mobile unit and could be towed along the lock wall. Electrical power was transmitted through 150 ft (45.7 m) of 3 conductor 2/0 AWG (10.62 mm) cable with an o.d. of 1.75 in. (44.5 mm).

The project schedule did not allow adequate time or effort to be placed on the design and fabrication of nozzles. This is undoubtedly one of the most critical components in the system. Instead, several nozzles

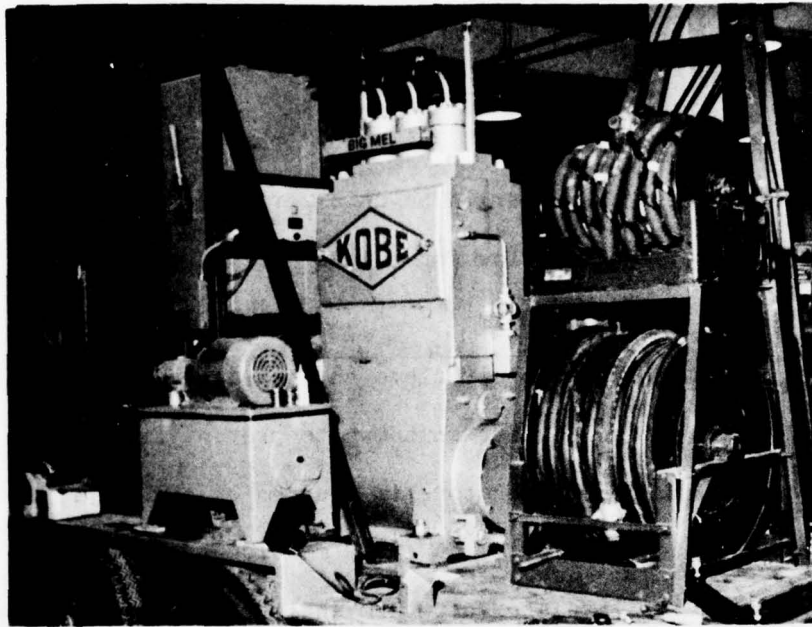

Fig. 1 Water Jet Components Mounted on Trailer (Enclosure Removed)

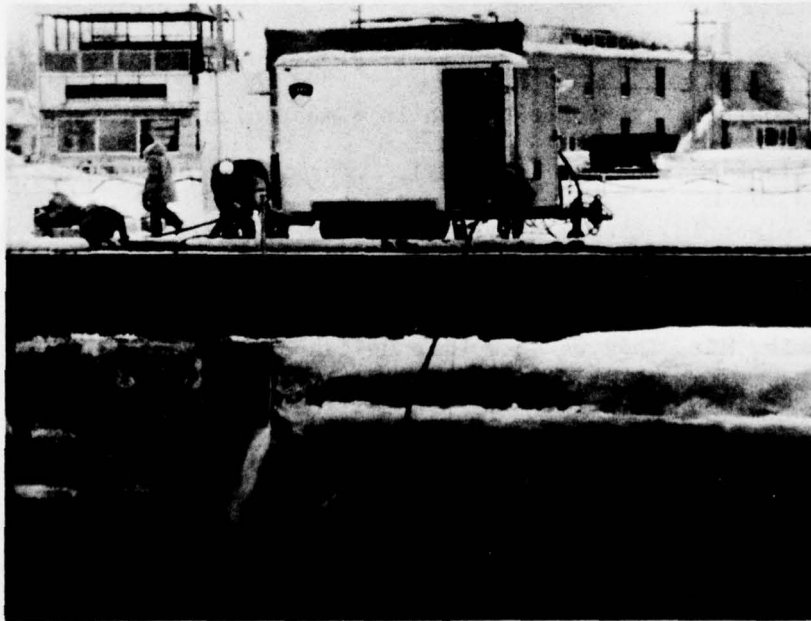

Fig. 2 Articulated Boom Mounted on Rear Corner of Trailer, Jet Assembly Holder

were purchased from three manufacturers: Tritan Crop. Arthur Products and Industrial High Pressure Systems. The nozzles sizes ranged from .059 inches (1.50 mm) to .125 inches (3.18 mm). Two nozzles were borrowed from NRC which had been used the previous season. Typical nozzle dimensions are shown in Figure 3.

#### Field Trials

Final assembly of the system was completed at the lock wall site and took about 9 days. The system was operational on 29 January 1976. Some glaring inadequacies were immediately evident.

The drive wheel could not provide the desired mobility over the snow covered surface. Movement was too erratic and maneuverability poor. The articulated boom supporting the jet assembly did not have adequate range and it was necessary to augment the jet positioning manually. The inlet water supply pump hanging from the boom mounted on the front of the trailer was vulnerable to large sections of falling ice cut-off from the ice collar. At times the circulation of anti-freeze solution could not be applied rapidly enough to prevent freeze-up in the lines.

The ice collar along the wall was about 12-24 inches (.3-.6m) in thickness and the bulk of the ice about 5 feet (1.5 m) deep most of which was well bonded to the wall. Ambient temperatures were generally -20°F to 0°F (-28.9°C to -17.8°C) with variable winds. Wind direction became an important consideration since any northerly breeze blew the spray from the jet back onto the lock wall surface where it froze.

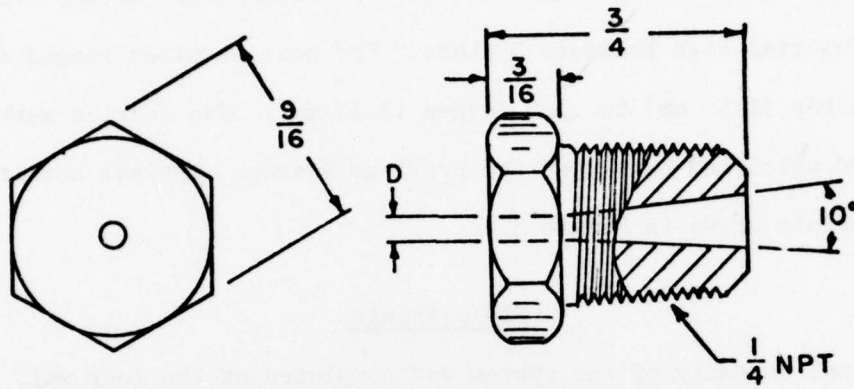

Commercial Cleaning Nozzle

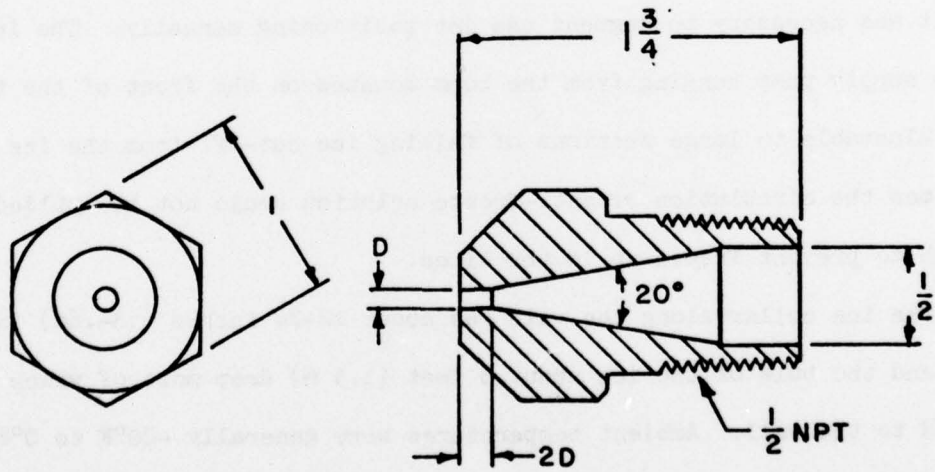

NRC Nozzle

Figure 3

### Cutting Tests

Most of the trials were conducted with a .086 inch (2.18 mm) diameter nozzle. The one from NRC which was probably eroded from previous usage reached a maximum pressure of 8700 psi (60 MPa) for a theoretical 96 HHP (hydraulic horsepower) (71.6 kW). Penetration was about 24 inches (.61 m) and the traverse rate was 2.5 ft/min, (.76 m/min) with a standoff distance of a few inches. After spalling of the ice between 2 ft (.6 m) and 3 ft (.9 m) the jet deflected off the remaining ice surface. Constant application by stopping the traverse resulted in complete penetration of the 5 ft (1.5 m) thick collar which indicated considerable penetrating ability even at the longer 2-3 ft (.61 - .92 m) standoff distance.

With an .086 inch (2.18 mm) diameter nozzle from Industrial High Pressure, pressures up to 9500 psi (MPa could be realized for a theoretical 105 HHP (78.3 kW). Maximum penetrations of 30 inches (.76 m) and maximum traverse rates of 2.7 ft/min. (.82 m/min) were obtained. Reversed passes were attempted over the remaining ice without lowering the jet and were successful but at slower rates.

The results were somewhat worse than those experienced the previous season at St. Lambert Locks and the Soo Locks (Brierley, 1975). It is felt that part of the poorer showing can be attributed to the lower ambient temperatures and stronger ice adhesion to the walls experienced this season.

Tests at high water level were also attempted. Rapid energy dissipation of the jet was quite obvious and the cutting action reduced considerably.

Several non-cutting tests were conducted with various nozzles to determine actual reaction forces, jet patterns, nozzle size-pump pressure characteristics and power efficiencies. These are summarized here:

#### Reaction Forces

Reaction forces are of interest in design of nozzle holders and were considerably less than first assumed. Theoretical reaction forces can be calculated from:

$$F = Q\rho (V_2 - V_1)$$

F = Reaction force (lbs or Newtons)

$\rho$  = Mass density (Slugs/ft<sup>3</sup> or Kg/m<sup>3</sup>)

Q = Volume flow (ft<sup>3</sup>/sec or m<sup>3</sup>/sec)

$V_1, V_2$  = Velocities before and after the section of interest. (ft/sec or m/sec)

Assuming the rated mass flow for the pump and the nozzle diameter are correct, actual measured values were about 82% of the calculated values for a pump delivery of 18.9 gal/min ( $1.19 \times 10^{-3}$  m<sup>3</sup>/sec) and nozzle diameter of .076 - .093 in (1.93 - 2.35 mm). For an .086 nozzle, the measured reaction was 73 lb (325 N).

#### Jet Patterns

Jet patterns are of interest since the more coherent jets retain more of the energy of cutting. Jet coherence is determined mainly by the nozzle entrance angle and entrance length. Figure 4 shows the difference between jets of an NRC nozzle and a commercial cleaning nozzle whose geometries

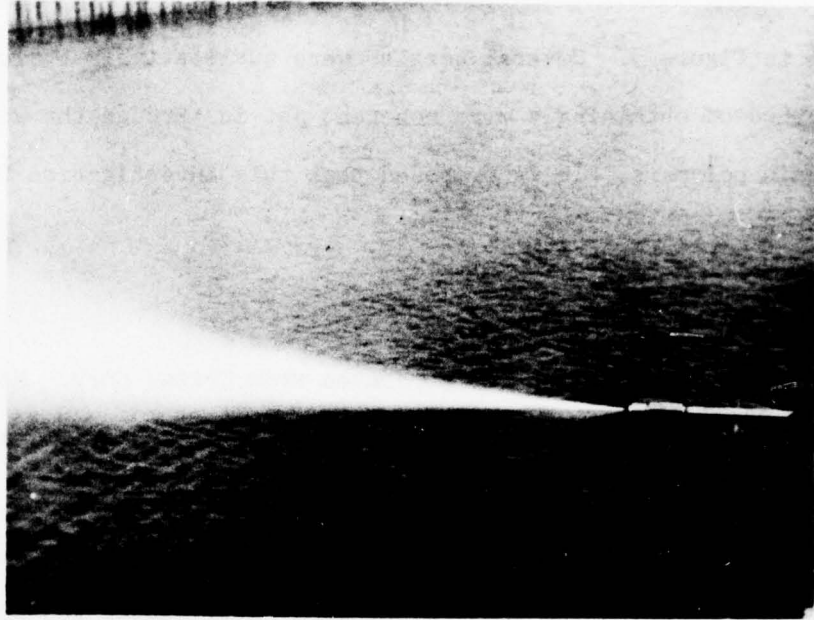

Commercial Cleaning Nozzle

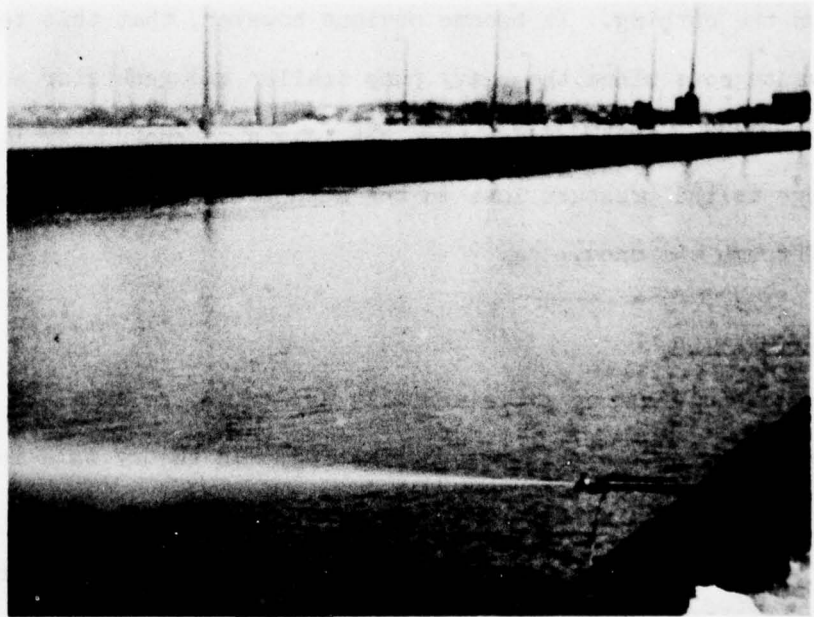

NRC Nozzle

Figure 4

were shown in Figure 3. Several nozzles were qualitatively evaluated. Another method of obtaining a more coherent jet is through the addition of long chain polymers. It is proposed that this investigation be made in the near future.

#### Hand Held Gun

A hand held cleaning gun was purchased from Tritan Corp. Normally these guns are operated at lower flows - 10 gal/min ( $.63 \times 10^{-3} \text{ m}^3/\text{sec}$ ) max.- so they can be physically managed by the holder. For this operation the gun was mounted on a roller assembly which would be pushed on the steel curbing which runs along the edge of the lock wall. Water was supplied to the gun by a long length of high pressure hydraulic hose previously described.

The apparatus withstood the reaction force but was too crude to run reliably on the curbing. It became obvious however, that this technique was highly advantageous since the heavy pump trailer and generator would require a minimum of movement, depending upon the length of the supply line. The disadvantage is the pressure loss in the supply line and the need to drag the line through the snow.

#### Pressure Generation

It was of interest to experimentally determine the smallest nozzle size compatible with the pump pressure rating. In theory this is about .073 in. (1.85 mm) dia. An .073 in. nozzle raised pump pressure to 14,000 psi (96.5 MPa) before the relief valve opened. It appears that rated pressure and flow for this pump can be achieved with a nozzle slightly larger than .073 in. (1.85 mm).

### Power Efficiency

Power measurements were made mainly to determine an overall efficiency factor and motor starting currents. Typical efficiency assuming a 0.9 power factor for the electric motor was about 81%.

### Conclusion and Recommendations

Although the results from this season's trials with the high velocity water jet were somewhat disappointing as a demonstration project, substantial data have been obtained, particularly in the operation of such a system. It remains a viable technique for lock wall de-icing. Some of the conclusions and recommendations drawn from this season's results are:

1. The system in its present design will cut up to 2.5 ft (.76 m) of ice at 2.7 fpm (.82 m/min). Optimum nozzle design to produce a more coherent jet should significantly increase the performance. Commercial cleaning nozzles do not produce the best cutting jets.
2. Moving the entire pump trailer is not recommended. The unit is simply too heavy and the snow surface too difficult to negotiate. A more practical approach would be to use a portable gun guided along the existing curbing and a long supply line.
3. Water jet cutting removes the ice cleaner than a mechanical cutter, at least down to the depth of penetration. It should perform considerably better, even in its present design, over sections of wall which have been polymer coated.
4. The use of a generator to operate the electric pump motor is expensive and inconvenient. With the reduced voltage motor starter employed

on the unit, it should be possible to start and operate the motor from local power sources with the addition of a transformer and distribution lines.

5. Wind direction and intensity are important factors in preventing the water spray from blowing back onto and freezing on the working surface and the operator.

6. A rapidly employable flushing system is important to prevent freeze-up within the system after shutdown.

7. Reaction forces from the jet, at least in this range of flow and pressure, are reasonable and about 82% of theoretical values.

8. Rapid deterioration of the cutting effectiveness of the jet at high water levels probably precludes the use of the jet on the high water end of the locks where some of the problems exist. Further investigations of the capabilities would have to be made.

References

- Brierley, W.H., Calkins, D.J., Den Hartog, S.L., Mellor, M., Ueda, H.T.,  
(1975) Lock Wall Deicing With Water Jets: Field Tests at Ship Locks  
in Montreal, Canada and Sault Ste. Marie, Michigan. USACRREL SR-239,  
Dec. 1975.
- Mellor, M. (1974) De-Icing Lock Walls With Water Jets - Preliminary Feasi-  
bility Study. USACRREL Technical Note, Feb. 1974.

## DEVELOPMENT OF LARGE ICE SAWS\*

Donald E. Garfield, Ben Hanamoto  
and Malcolm Mellor

### INTRODUCTION

In order to maintain year-round navigation in the Great Lakes system, the locks at Sault Ste. Marie, Michigan, have to be operated throughout the winter. One of the problems that arises during winter operation of the locks is that ice collars form on the lock walls near high pool elevation, reducing the effective width of the locks. The widest lock, Poe Lock, is 110 ft wide, only 5 ft wider than the widest ships on the lakes, the *Roger Blough* and the *Presque Isle* (Fig. 1). Without remedial action, the total width or thickness of the ice collars can easily exceed 5 ft, thus making navigation of the lock impossible.

Two processes form ice collars: the direct freezing of water on cold walls, and the crushing of floating ice against the walls by ship hulls. In both cases, adhesion to the lock wall depends on the temperature of the wall being below 0°C. Where water level is constant immediately above and below the mitre gates, the ice collars that form at the splash line are small (Fig. 2). However, at Soo Locks the water level in the active lock is always held well below (5 to 17 ft below) high pool elevation; consequently, the ice collars that form on the air-cooled wall are very deep (Fig. 3), commonly 8 ft deep or so.

As part of the Great Lakes Winter Navigation Program, CRREL has been developing methods for clearing ice collars from lock walls. The methods considered for keeping walls clear of ice have included heating, coating with chemicals, covering with inflatable deicing boots, cleaning with high-pressure water jets, and mechanical cutting. This report deals with the development of large chain saws for cutting off ice collars.

\*USACRREL Report 76-47 December 1976

### PERFORMANCE SPECIFICATIONS

Performance specifications of chain saws were developed at CRREL through consultations with people familiar with the overall problem. The chief difficulty was in deciding the depth of ice collar that had to be tackled. Direct observations at the site gave the impression that the thickness of ice collars could perhaps be reduced to about 2 ft by maintaining water level near high-pool elevation during the very long periods between ship passages. However, such a procedure was not in operation at the time of the study; therefore, the saws were designed to cut an average thickness of 6 ft of ice, with provision for cutting through 8 ft or so at reduced travel speed.

The specification adopted for the saw's rate of working was highly arbitrary. It was assumed that a single machine ought to be capable of clearing ice from both walls of the lock each day. This was taken to mean that the saw had to cut at least 2000 linear feet in 8 hours. (The complication of how to transfer a machine from one side of the lock to the other was ignored at this stage.) However, from preliminary design calculations, this requirement seemed too lax in that it could probably be met without much effort. It was therefore changed to one for cutting 1000 linear feet of 6-ft-deep ice in 1½ hours, which seemed to be a realistic goal for efficient design.

### DESIGN CONCEPT

The general idea was to use a chain saw moving parallel to the lock wall to slice through the ice within a few inches of the ice/wall interface. The working section of the chain saw bar had to be at least

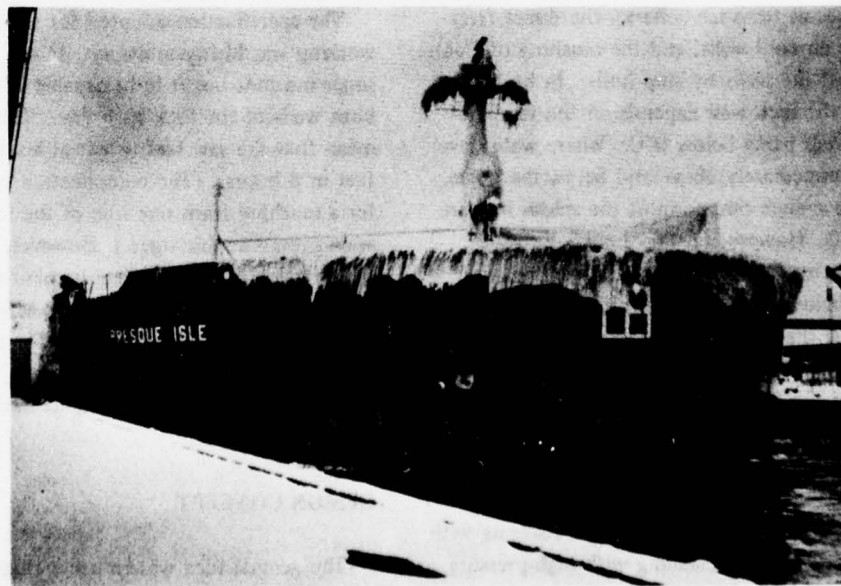
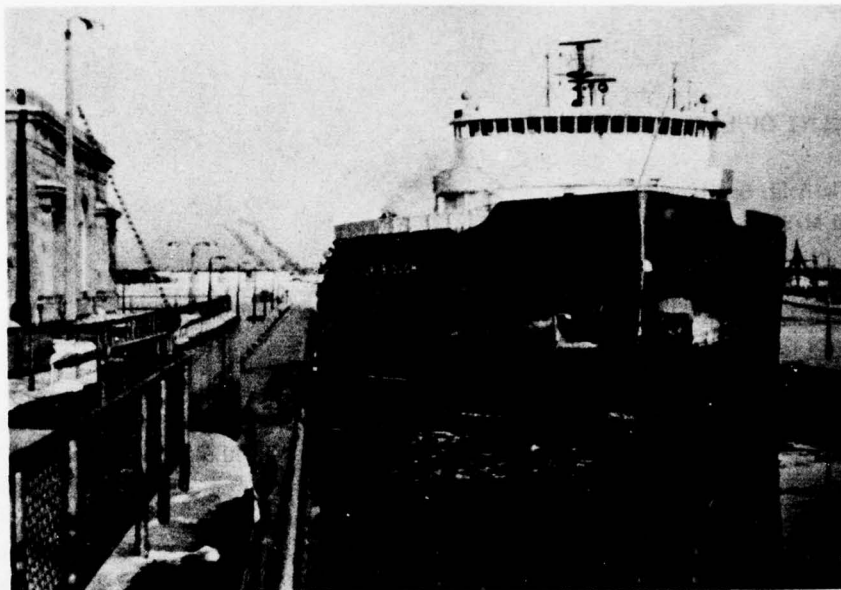

*Figure 1. Ore-carriers Roger Blough and Presque Isle at Soo Locks.*

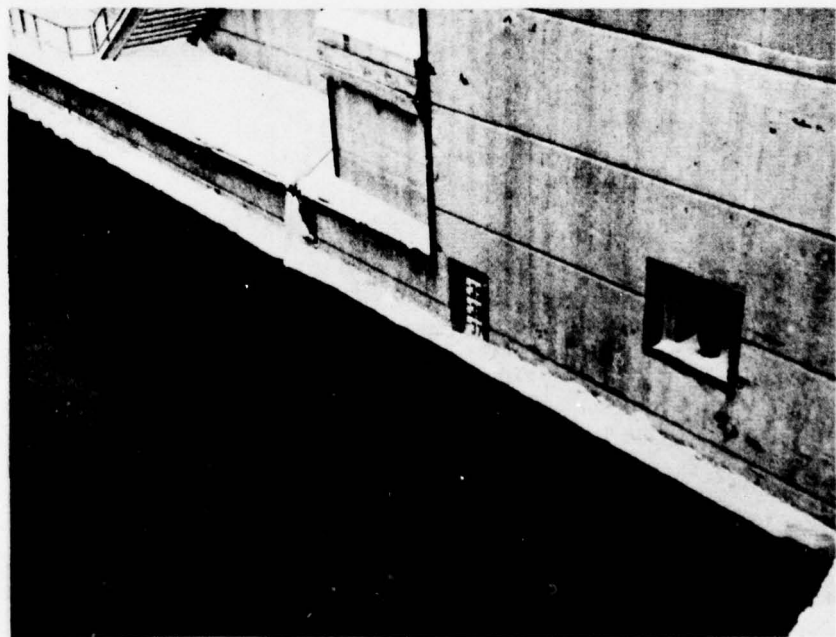
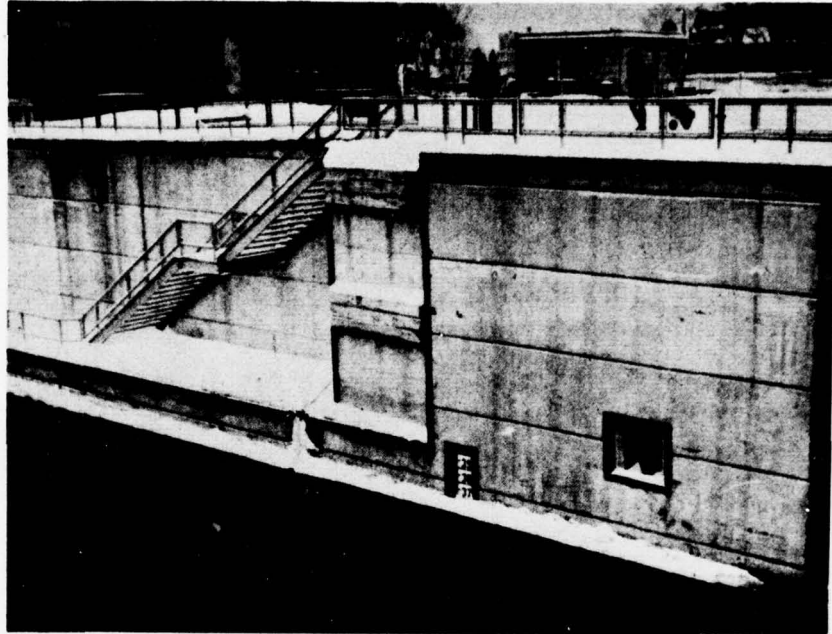

*Figure 2. Thin ice collars formed downstream of lower mitre gate, where water level does not fluctuate much.*

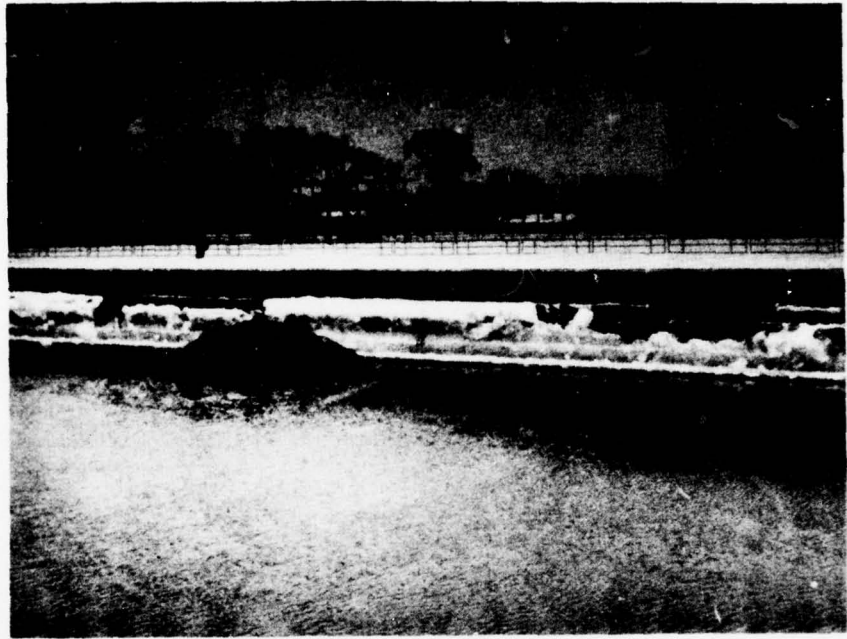

*Figure 3. Deep ice collars at Poe Lock.*

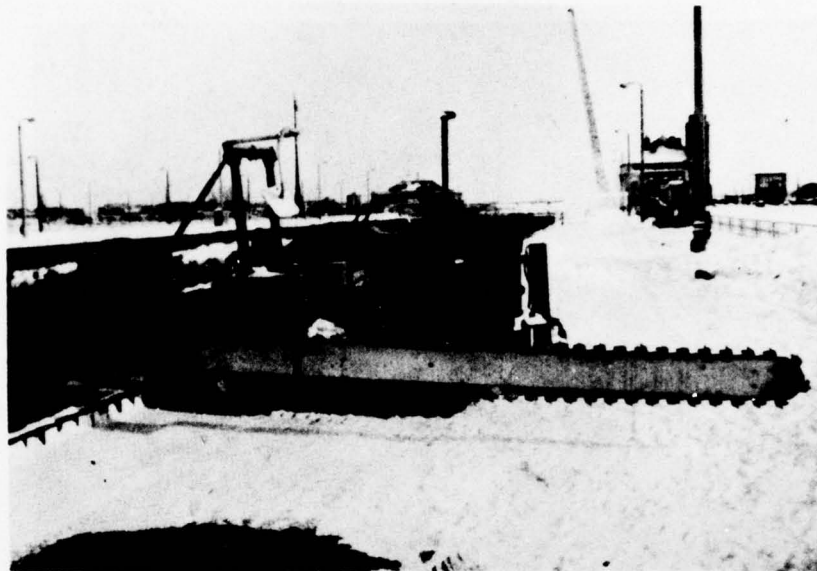

Figure 4. Thin-kerf coal saw mounted on offset-drive soil trencher.

8 ft long to slice through 8 ft of ice at a single pass, and additional length was needed to accommodate the drive mechanism. There were two possible arrangements: 1) to have the shortest possible bar held into the work by a boom, with electric or hydraulic power supply; or 2) to have a long bar reaching down from the carrier vehicle, with direct drive from that vehicle. The latter seemed the more practical arrangement, even though it required a very long bar (at least 8 ft of cutting length, about 5 ft of reach from the top of the ice collar to the level of the esplanade pavement next to the wall, and additional reach from the pavement level to the chain saw drive shaft on the carrier).

Ideally, the chain saw should cut a very narrow kerf in order to minimize force levels and power requirements. On the other hand, the bar should be reasonably stiff, and the cutting chain should be capable of withstanding occasional abuse. The type of saw selected for the main development effort was a "thin kerf" coal saw that is used in small underground mines. This was mated with a small rubber-tired soil trencher that had an offset drive (Fig. 4). For a secondary effort, a large lumber-cutting chain saw (deck or pond saw) was mounted on a very small soil trencher (Fig. 5). Both machines were intended to travel along the lock

esplanade with their saw bars hanging down with a forward inclination of about  $20^\circ$  to the vertical (Fig. 6).

#### Details of the coal saw machine

The coal saw, the heavier of the two machines, had as its cutting unit a coal saw manufactured by the Bowditch Company. The overall length of the bar was 16 ft, the bar width to the chain guides was  $9\frac{1}{2}$  in., and the actual thickness of the bar was  $1\frac{5}{8}$  in. The width of kerf cut by the gage cutters of the chain was  $3\frac{1}{4}$  in., and the bar width measured to the tips of the cutting teeth was 15 in. The pitch diameter of the chain's drive sprocket was 8.09 in. The reversible and replaceable cutting teeth had rake angles of  $+10^\circ$  and relief angles of  $50^\circ$ , with the included angle  $30^\circ$ . The maximum gage (maximum chipping depth) was 0.9 in. for an unworn tool. A link of the chain fitted with a cutting tooth is shown in Figure 7. The pitch of the chain was  $2\frac{1}{2}$  in., and there was a cutting tooth every 5 in. The cutting teeth were angled out of the plane of the kerf to give 7 cutting tracks across the width of the kerf.

The large chain saw was mounted on the tractor of a soil trencher, the Ditch Witch R65. Preliminary design calculations indicated that power requirements for cutting a  $3\frac{1}{4}$ -in. kerf in 6 ft of ice at a traverse

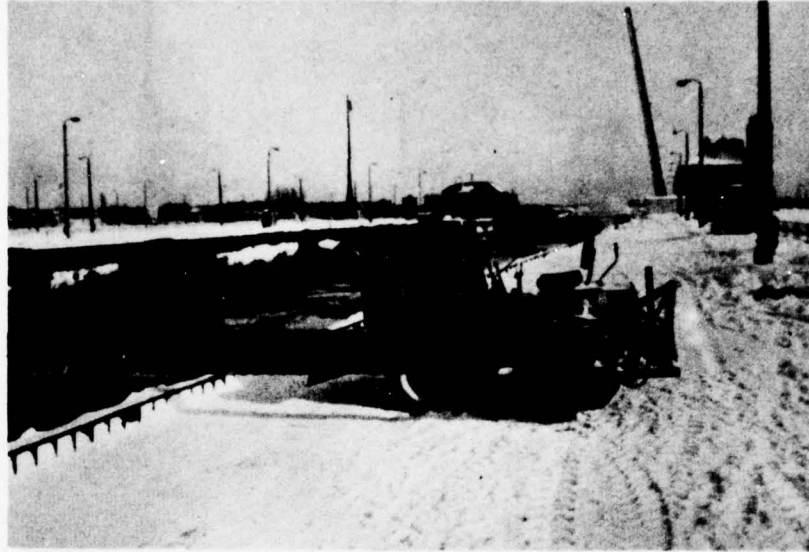

*Figure 5. Large lumber-cutting chain saw mounted on small soil trencher.*

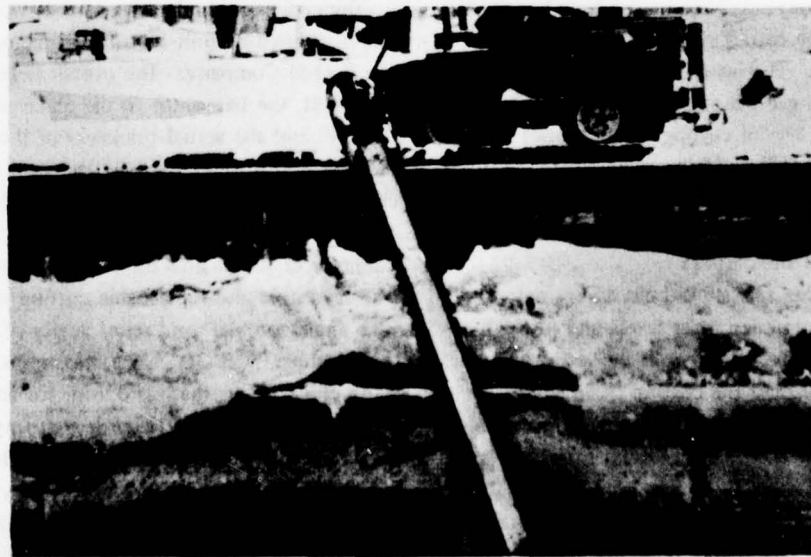

*Figure 6. Cutting mode, bar with forward inclination of about 20°.*

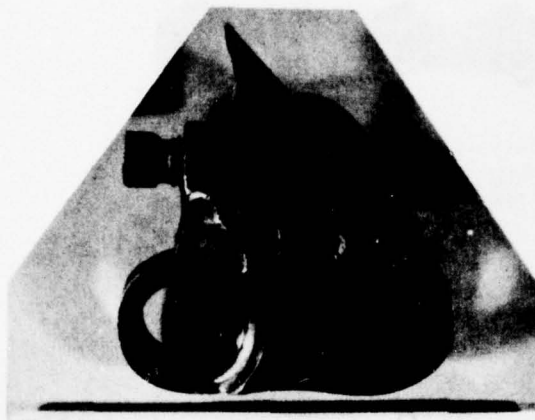

Figure 7. Chain link and replaceable hardfaced cutting tooth for coal saw.

rate of 12 ft/min would call for a minimum of 50 hp, assuming a specific energy of 500 lbf/in.<sup>2</sup> for cutting ice. Action was initiated to purchase a tractor unit, with factory modifications to adapt the Bowdil coal saw. When it became obvious that this could not be accomplished in time to meet the test schedule, it was decided to purchase a tractor without attachments and adapt the saw at CRREL.

A Ditch Witch Model R65 and offset trenching attachment, manufactured by Charles Machine Works, Inc., Perry, Oklahoma, were purchased. This tractor, without attachments, weighs 4100 lb and has a wheelbase of 59 in., an overall length of 138 in., an overall width of 72 in., an overall height of 95 in., and a width of 64 in. at the outside of standard 32x9:00x16 tires. The tractor has a 65-hp Wisconsin air-cooled engine that delivers 63 hp at 2600 rev/min. The trencher is driven through a 4-speed transmission, which rotates the output shaft at no-load speeds of 35 rev/min in first, 77 rev/min in second, 137 rev/min in third, and 241 rev/min in fourth gear. Tractor groundspeed in the trenching mode is continuously variable from 0 to 37.5 ft/min. The tractor is equipped with full-time 4-wheel drive and power steering.

With the 8.090-in. pitch diameter sprocket furnished by Bowdil Company, the maximum chain speed attainable was about 510 ft/min. Bowdil Company had advised that the maximum chain speed should be limited to 200 ft/min, so the 510 ft/min

was a compromise between the original 600 ft/min requirement and Bowdil's recommendation.\*

The factory-made offset trenching attachment was designed for a bar offset of about 27½ in. from the tractor centerline. For operation on the locks, an additional offset of approximately 28 in. was required. This was accomplished by welding a flange to the existing trencher pivot assembly and cantilevering a torque tube from this flange. This torque tube could be rotated to provide vertical bar movement by using the original boom hydraulics. An outer sleeve bearing was braced to the front of the tractor and to the top of the rollover protective frame to provide additional support near the outer end of the torque tube. A drive shaft extension ran through the center of the torque tube and was supported by a ball bearing at the end of the torque tube. A bell crank was bolted to the end of the torque tube. The chain saw bar was bolted through slots in the bell crank arm, which provided chain tension adjustment.

Preliminary calculations indicated that the tractor hydraulics might not raise the chain saw bar to the horizontal position. When the unit was assembled the evening before it was to be shipped, it was discovered that the bar could not be raised to the horizontal position. Therefore, an extension to the cylinder crank arm on the pivot assembly was fabricated to correct this problem. This modification limited bar travel, but was still within design requirements. Drawings of the fabricated components are available at CRREL.

The stability of the tractor during cutting operations was of some concern, since the weight of the bar and chain (approximately 1200 lb), and the weight of the vertical component of the cutting force, would have a tendency to overturn the tractor into the lock. However, calculations showed that, with the outboard tires loaded with calcium chloride solution and additional wheel weights, overturning would not be a problem. Even if the tractor did begin to tip, the end of the bar would contact the lock wall and prevent further tipping.

\* Coal cutter chains are routinely designed to run at speeds up to 850 ft/min.

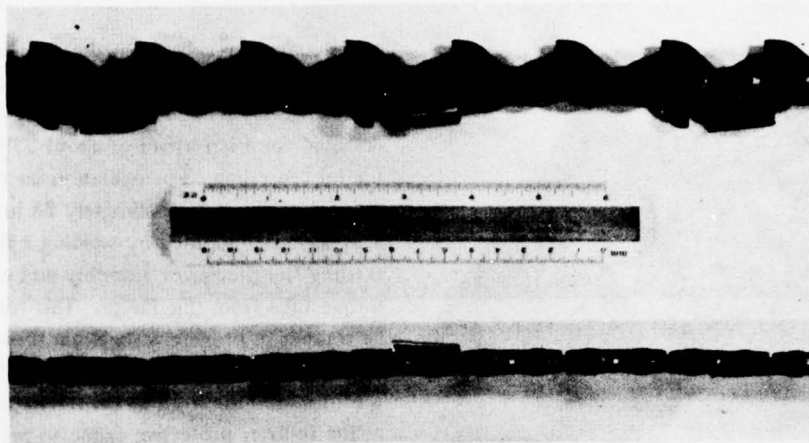

Figure 8. "Skip tooth" modified lumber chain.

#### Details of the lumber-cutting saw machine

The cutting unit on the small machine was basically a logging industry deck saw. It was supplied by the L-M Equipment Company, Inc., Portland, Oregon, and had a chain made by the Oregon Chain Saw Division of Omark Industries, Portland, Oregon. The chain was a "skip-tooth" modification of an Oregon 11BC chipper chain, which had a 0.78-in. pitch and a tooth every 4.7 in. along the chain (alternately left and right teeth). Most of the teeth had the top parts ground away (Fig. 8) so that they only cut at the gage limits. A pair of original teeth were left intact after each set of 2 reground teeth. The effective rake angle was approximately  $+25^\circ$  and the relief angle was  $5^\circ$ . The overall length of the cutter bar was 14 ft 4 in., its width was  $11\frac{3}{4}$  in., and its thickness was approximately  $\frac{9}{16}$  in. The kerf cut by the chain was 0.56 in. wide, and the maximum chipping depth, determined by the projection of the cutting edge beyond the raker, was 0.06 in.

Preliminary design calculations indicated that approximately 6.5 hp would be required to cut a  $\frac{9}{16}$ -in. kerf in 6-ft-thick ice while the saw was travelling at the rate of 12 ft/min. Allowing for inefficiencies in the system, the minimum horsepower required was 10 to 12 hp. CRREL had a Ditch Witch Model V30 trencher, which seemed ideal for mounting the pond or deck saw.

The V30 trencher weighs approximately 2800 lb and is powered by a Wisconsin VH4D 30-hp air-cooled engine. The overall tractor width is 64 in. and the overall length is 118 in. without the saw or

digging attachments. The wheelbase is  $46\frac{3}{8}$  in., and the width to the outside of the  $27 \times 8.50 \times 15$  tires is 56 in.

The saw mandrel and V-belt drive were mounted on a frame which was hinged to the side of the tractor. An adjustable top link assembly allowed for fixing the saw bar in a position parallel to the lock wall. This arrangement also would provide a method for automatically keeping the bar parallel to the lock wall by using a servo-controlled hydraulic cylinder in place of the top link assembly. Such an arrangement is desirable if the esplanade pavement next to the wall is not kept completely free of ice and snow. Otherwise, any vertical movement of one vehicle tire with respect to the other results in a greatly amplified horizontal movement of the tip of the saw bar, and may cause the chain to gouge the lock wall, either damaging the chain or the wall. Tractor hydraulics were utilized to raise and lower the bar. A four-bar linkage arrangement was designed to rotate the bar through  $110^\circ$  from approximately  $5^\circ$  above horizontal to  $15^\circ$  beyond vertical. In its original configuration, the trencher drive rotated at a maximum speed of 230 rev/min. To operate the chain at the desired 1200 ft/min, the trencher drive pulleys were interchanged and an additional speed increase was provided with a second V-belt drive.

## FIELD TESTS

Tests were made on the Poe Lock at Sault Ste. Marie, Michigan, during early February 1976. Both saws were hoisted onto the esplanade of the south wall (i.e., north-facing, or shaded, wall) from a barge operated by the Sault Area Office. Test runs were made when there was a heavy ice collar extending from about 5 ft below the esplanade pavement to about 13 ft below the esplanade pavement. The ice was the dense, impermeable kind, as distinct from the weaker, and more permeable, material crushed onto the wall after recent ship passage. Air temperatures during the test period were in the range  $-9^{\circ}$  to  $-22^{\circ}\text{C}$ .

To start a fresh cut, the saw bar was lowered slowly from its horizontal stowed position, so that the nose and rear side of the bar were cutting into the ice collar. During this starting cut, the untensioned side of the chain was working, and there was a potential for throwing the chain out of its guides. Therefore, it seemed beneficial to inch the tractor forward occasionally during the course of a starting cut. When the bar reached its normal operating position, the tractor began its forward travel, and the side of the chain tensioned by the drive sprocket did the cutting.

Testing was simply a matter of determining the maximum sustainable travel speed of the tractor when the saw was cutting. The limit of speed in these tests was set by available engine power; the saw drive began to lug down as travel speed became too high. Under other circumstances the limit might be set by available traction, by high force levels, or by inadequate clearing of cuttings.

An unsuccessful attempt was made to determine the normal component of force on the large cutter bar. The plan was to tow the carrier vehicle through a dynamometer, both with the saw operating in a vertical position and with the saw withdrawn from the work. However, the small tractor, which was the only tow vehicle available, was unable to pull the larger tractor when its saw was operating (the hydraulic drive motor ports are blocked off, preventing rotation of the drive train).

The heavier saw (coal saw) was able to travel at 9 to 10 ft/min while cutting through ice 4 to 6 ft thick, and at 6.5 to 6.7 ft/min while cutting through ice 7 to 8 ft thick. These rates were achieved with the drive shaft running at its maximum speed of about 235 rev/min in fourth gear.

The small (lumber-cutting) saw could cut through 5 to 6 ft of ice at speeds of 2 to 3 ft/min with the tractor in third gear and the output shaft turning at 610 rev/min. However, the flexible bar of the small saw was easily deflected, and it tended to ride out of the work at transitions from a thin section of ice to thicker ice.

## DESIGN CALCULATIONS AND PERFORMANCE ANALYSIS OF COAL SAW

### Chipping depth

During the initial design of the heavier saw, a capability for forward travel at 12 ft/min was proposed to permit clearing of a 1000-ft-long wall in 1½ hours, allowing 7 minutes for stoppages. It was expected that a chain speed of 600 ft/min would be available, and it was expected that the cutting teeth of the large saw would be set to give 5 cutting tracks across the width of the kerf, instead of the 7 tracks as furnished. The planned operating position for the saw was at an inclination of  $70^{\circ}$  to the horizontal.

The theoretical chipping depth  $\ell$  of the teeth is given by

$$\ell = \frac{U}{u_t} S \sin \phi \quad (1)$$

where  $U$  is the traverse speed,  $u_t$  is the tool speed (chain speed),  $S$  is the distance between tracking cutters, and  $\phi$  is the inclination to the horizontal [see Mellor (1976)]. The Bowditch Company chain has cutters spaced every 5 in.; so with 5 cutting tracks,  $S$  is 25 in. Thus, the theoretical chipping depth under the expected conditions is:

$$\ell = \frac{12}{600} \times 25 \times 0.9397 = 0.47 \text{ in.} \quad (2)$$

The actual chipping depth was expected to be less than this value as a result of overbreak and interaction between adjacent parallel kerfs (see Mellor, in prep.). With an overbreak angle greater than about  $41^{\circ}$ , adjacent kerfs would have some overlap.

The test machine was prepared hurriedly to meet project schedules, and not until it was finally assembled and run at the test site were its actual characteristics determined. In reality, the cutters on the chain were set to give 7 cutting tracks, and the maximum chain speed reached during working was 492 ft/min. Thus, the theoretical chipping depth was:

$$\varrho = \frac{U}{492} \times 35 \times 0.9397 = 0.0668U. \quad (3)$$

At 12 ft/min this would give a theoretical chipping depth of 0.80 in., and at 10 ft/min a theoretical chipping depth of 0.67 in. For interaction between adjacent kerfs, the overbreak angle would have to exceed 19° and 12 ft/min and 22° at 10 ft/min. Although the overbreak angle for the Bowdil Company tool in ice has not been measured, it is expected that it would be at least 50°. With 7 cutting tracks across a 3 1/4-in. overall kerf, and with an overbreak angle of 50°, the actual chipping depth would not be more than about 0.46 in. With an overbreak angle of 70°, actual chipping depth would not be much over 0.2 in.

#### Clearance of cuttings

Another consideration is the ability of the chain to convey cuttings out of the kerf without clogging the cutting teeth. Around each tooth there must be enough space to accommodate the cuttings accumulated during a complete sweep through the work. A simple criterion for adequacy of cutting conveyance is given by:

$$(1 - s_t/S)(h_t/d) > K_b U/u_t \quad (4)$$

where  $s_t$  is the equivalent length of the tool,  $h_t$  is the equivalent tool height (such that  $s_t h_t$  is the volume per unit width of the tool),  $S$  is the distance between tracking cutters,  $d$  is the depth of cut measured normal to the traverse direction, and  $K_b$  is a bulking factor that can be taken as 1.85 [see Mellor (1975) for details].

For the Bowdil Company tool,  $s_t$  and  $h_t$  are taken as 2.25 and 2.5 in., respectively, and for a 7-track tool layout  $S = 35$  in. With these values the condition for adequate conveyance is:

$$(U/u_t)d < 1.26 \quad (5)$$

where  $d$  is in inches. With a 6-ft-deep ice collar and a chain speed of 492 ft/min, the maximum travel speed, according to this criterion, is 8.6 ft/min. With an 8-ft-deep ice collar, the maximum travel speed for adequate cutting clearance is 6.5 ft/min. According to these calculations, the heavy chain saw has cutting clearance arrangements that are barely adequate at the maximum available chain speed, and there is some dependence on spillage and compaction. With

the planned chain speed of 600 ft/min and the planned 5-track tool arrangement, cutting clearance would have been just adequate at a traverse speed of 12 ft/min in 6 ft of ice.

#### Specific energy

During the initial design it had been hoped that the specific energy for the cutting processes could be brought down to approximately 100 to 200 lbf/in.<sup>2</sup> The test program made no provision for measuring power consumption for the cutting process, but from rough estimates, it appears that energetic efficiency was appreciably worse than had been hoped.

The rated power output of the tractor engine was 63 hp. From this, 5 hp might be subtracted for running the hydraulic system (including the wheel drives), for driving the alternator, etc. Assuming 80% efficiency for the complex mechanical transmission of the power takeoff, this leaves 46 hp for delivery to the drive sprocket of the chain saw. The manufacturer of the coal saw advised that approximately 15 hp would be needed to run the chain without cutting, so that if this is deducted the power available for cutting ice would be 31 hp.

The specific energy  $E_s$  is the energy per unit volume of material cut [see Mellor (1975)], which is the same thing as the power  $P$  divided by the volumetric cutting rate  $V$ :

$$E_s = \frac{P}{V} = \frac{31 \times 3.3 \times 10^4}{(3.5/12) \times d \times U} = \frac{3.51 \times 10^6}{dU} \text{ lbf/ft}^2 \quad (6)$$

where actual width of the finished kerf is taken as 3.5 in. and the cutting depth  $d$  and the traverse speed  $U$  are in feet and feet per minute, respectively. The test results for the thin-kerf coal saw gave values of  $(dU)$  from 47 to 60 ft<sup>2</sup>/min; the corresponding range for  $E_s$  is 7.46 × 10<sup>4</sup> to 5.85 × 10<sup>4</sup> lbf/ft<sup>2</sup>. In the more familiar units of lbf/in.<sup>2</sup> (i.e., in-lbf/in.<sup>3</sup>), the range for  $E_s$  is 518 to 406 lbf/in.<sup>2</sup> These values are higher than had been hoped for, but they are much lower than the specific energy estimated from the performance of a Joy 10RU coal saw cutting glacier ice in Greenland (1740 lbf/in.<sup>2</sup>, without making allowance for losses of energy due to chain friction).

#### Tooth forces and bar forces

With the sharp, new cutting teeth used during the tests, it is probably realistic to assume that the

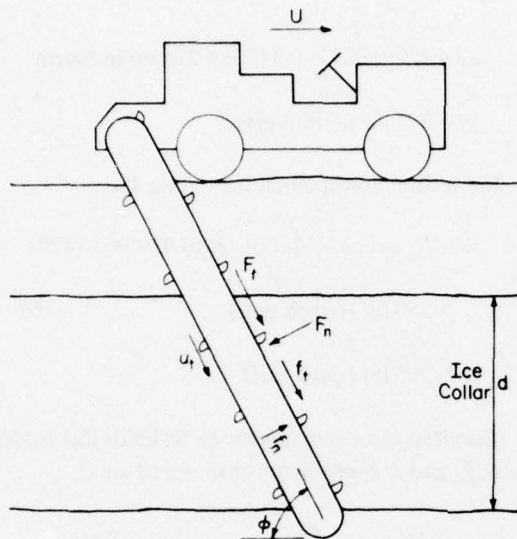

Figure 9. Force diagram.

tangential component of tooth force  $f_t$  and the normal component of tooth force  $f_n$  are approximately equal [see Mellor (in prep.) for details]. This assumption also implies that the total tangential force on the cutting bar  $F_t$  is approximately equal to the total normal force on the bar  $F_n$ .

The power needed for cutting is given by the tractive thrust of the tractor multiplied by the tractor speed, plus the tangential force on the cutter bar multiplied by the chain speed (see Fig. 9):

$$P = (F_n \sin \phi - F_t \cos \phi)U + F_t u_t \quad (7)$$

where  $\phi$  is the angle of the cutter bar from the horizontal ( $\approx 70^\circ$ ). Since  $u_t$  is about 50 times greater than  $U$ , the power consumed in thrusting the cutter bar horizontally  $[(F_n \sin \phi - F_t \cos \phi)U]$  can be neglected. If 31 hp is used in the cutting process when operating at maximum speed, and if the chain speed  $u_t$  is 492 ft/min, the tangential bar force is:

$$F_t = P/u_t = (31 \times 3.3 \times 10^4)/492 = 2079 \text{ lbf.} \quad (8)$$

As indicated earlier, it is assumed that  $F_n$  is equal in magnitude to  $F_t$ . Thus, the net tractive thrust  $H$  that the tractor has to provide is:

$$\begin{aligned} H &= F_n \sin \phi - F_t \cos \phi = 2079(0.9397 - 0.3420) \\ &= 1243 \text{ lbf.} \end{aligned} \quad (9)$$

The vertical downpull on the tractor  $V$ , excluding bar weight, is:

$$\begin{aligned} V &= F_n \cos \phi + F_t \sin \phi = 2079 (0.3420 + 0.9397) \\ &= 2665 \text{ lbf.} \end{aligned} \quad (10)$$

The mean tangential force on an individual cutting tooth when the saw is being operated at maximum performance is  $F_t$  divided by the number of teeth in the work:

$$f_t = f_n = \frac{F_t}{(d/\sin \phi)/(5/12)} = 866 \sin \phi / d \text{ lbf} \quad (11)$$

where  $d$  is the depth of the ice collar in feet. With  $\phi = 70^\circ$ , tooth force  $f_t$  or  $f_n$  is 203 lbf when  $d = 4$  ft and 102 lbf when  $d = 8$  ft.

## DESIGN CALCULATIONS AND PERFORMANCE ANALYSES - LUMBER-CUTTING SAW

### Chipping depth

With its output shaft turning at 880 rev/min, the chain speed on the lumber-cutting saw was 1152 ft/min. Regarding the cutting teeth as simply left or right, without taking account of tooth width after grinding, the space between tracking cutters  $S$  is 18.75 in. At a bar angle of  $70^\circ$ , the theoretical chipping depth is therefore 0.031 in. at a traverse speed of 2 ft/min and 0.046 in. at a traverse speed of 3 ft/min.

### Clearance of cuttings

As previously defined, with an equivalent length of tool,  $s_t = 1.0$  in., equivalent tool height  $h_t = 0.5$  in., distance between tracking cutters  $S = 18.75$ , bulking factor  $K_b = 1.85$ , the condition for adequate conveyance is:

$$(U/u_t)d < 0.256. \quad (12)$$

When the tractor is operated in third gear with a drive-shaft spread of 610 rev/min, the chain speed  $u_t$  is 798 ft/min. With the saw cutting an ice collar with a depth  $d$  of 6 ft, the maximum travel speed  $U$  is 2.84 ft/min. In fourth gear with a drive-shaft spread of 880 rev/min, the chain speed increases to 1152 ft/min and  $U$  is 4.09 ft/min for adequate cutting clearance. The small lumber saw therefore has cutting clearance

arrangements which are not adequate to meet the proposed 12-ft/min maximum traverse speed. The maximum recommended chain speed is 1200 ft/min.

#### Specific energy

The tractor used to power the lumber-cutting chain saw was rated at 30 hp. While the saw is in the cutting mode, other power requirements include the power required for running the hydraulic drive system and that required for running the accessories. Assuming 5 hp is required for the above, an 80% efficient power train to the power takeoff, a 90% efficient saw mandrel and drive pulley system, the available power to the sprockets is about 18 hp. If 3 hp is needed to spin the chain, 15 hp is available for cutting. The volumetric cutting rate  $\dot{V}$  is  $kdU$ , with the cutting kerf  $k = 9/16$  in. Then the specific energy  $E_s$  is:

$$E_s = \frac{P}{\dot{V}} = \frac{15 \times 3.3 \times 10^4}{(0.5625/12)(dU)} = \frac{1.06 \times 10^7}{dU} \text{ lbf/ft}^2. \quad (13)$$

At the speed where adequate cutting conveyance occurs, 4 ft/min and through 6-ft ice,  $E_s = 4.40 \times 10^5$  lbf/ft<sup>2</sup> = 3056 lbf/in.<sup>2</sup> At a traverse speed of 10 ft/min,  $E_s$  becomes 1220 lbf/in.<sup>2</sup>, a figure much higher than that for the coal saw, and nowhere near the hoped for values of 100 to 200 lbf/in.<sup>2</sup>

#### Tooth forces and bar forces

Assuming that the tangential and normal components of the tooth force are equal and total tangential forces  $F_t$  = total normal force  $F_n$ , and neglecting the power consumed in thrusting the bar horizontally, then

$$F_t = F_n = \frac{P}{u_t} = \frac{(15)(3.3 \times 10^4)}{1152} = 429 \text{ lbf in fourth gear} \quad (14)$$

$$F_t = F_n = 620 \text{ lbf in third gear.}$$

The net tractive thrust  $H$  required from the tractor is:

$$H = F_n \cos\phi - F_t \sin\phi \text{ with } \phi = \text{bar angle from horizontal} = 70^\circ$$

$$H = 429(0.9397 - 0.3420) = 256 \text{ lbf in fourth gear}$$

$$H = 371 \text{ lbf in third gear.}$$

The vertical downpull on the tractor  $V$  is:

$$V = F_n \cos\phi + F_t \sin\phi = 429(0.9397 + 0.3420) = 550 \text{ lbf (fourth gear)} \quad (16)$$

$$V = 795 \text{ lbf (third gear).}$$

The mean force components on an individual cutting tooth  $f_n$  and  $f_t$  at maximum chain speed are:

$$f_t = f_n = \frac{F_t}{(d/\sin\phi)(4.7/12)} = 26.3 \text{ lbf for a collar depth of 6 ft.} \quad (17)$$

#### CONCLUSIONS AND RECOMMENDATIONS

The use of large chain saws for cutting ice is far from being a new idea. During tunneling operations at the edge of the Greenland Ice Cap in 1957, a Joy 10RU coal cutter with a 9-ft-long bar was used (Abel 1961). The average cutting rate was 2 ft/min, with 7.5 to 9 ft of bar engaged in the work (kerf width was 6.5 in.). More recently, the University of Alaska, and later, the U.S. Naval Civil Engineering Laboratory (USNCEL), adapted two small soil trenchers (both crawler track types) for cutting ice. These machines were a Davis TF-700 and a Davis TF-1000 (J.I. Case Co.), both fitted with 8-in.-wide "frost chains" and re-equipped with sharp 30° conical steel teeth to replace the carbide-tipped teeth normally used in frozen soils. The TF-700 machine, with a 30-hp engine, achieved a cutting rate of 13.9 ft/min in 31-in.-deep artificial sea ice, while the TF-1000 machine (Fig. 10), with a 60-hp engine, reached 10 ft/min in 72-in.-thick sea ice (Vaudrey 1975, Brier and Vaudrey 1975). Small ladder trenchers were also used during the 1975/76 winter at Prudhoe Bay to cut 6-ft-thick sea ice.

There is no longer any doubt that large chain saws can be very effective tools for cutting ice. However, efficiency can vary within wide limits depending on the design and layout of teeth, and on the mode of operation of the saw (chain speed, traverse speed, thrust force, etc.). The coal saw used for tunneling in

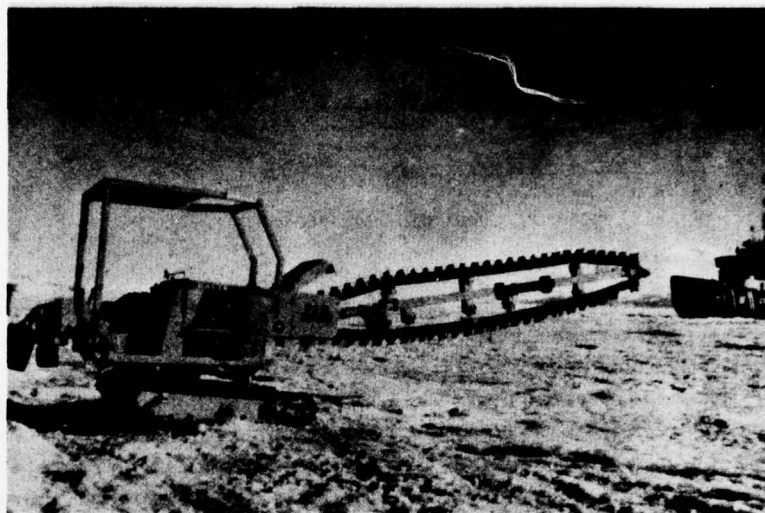

Figure 10. USN CEL ice saw (developed from soil trencher).

Greenland was obviously very inefficient, even when the most favorable assumptions about power consumption are made. At the other extreme, the ladder trenchers adapted by USN CEL were very efficient ice cutters according to the reasonable power assumptions that were made — both machines achieved process specific energy values of approximately 200 lbf/in.<sup>2</sup> (compared with 400 to 500 lbf/in.<sup>2</sup> for the lock wall coal saw working in cold freshwater ice). Note that the USN CEL saws were symmetrically mounted on relatively heavy crawler tractors that were capable of providing substantial force reactions; low chain speeds were used (90 ft/min on the TF-700), so that the tangential cutting forces must have been comparatively high. On the lock wall saws, it was necessary to run the offset bars at high chain speeds to minimize overturning moments and to avoid control problems with the light rubber-tire tractors.

The modified lumber-cutting chain saw unit is unacceptable for removing ice from the lock walls because of two major deficiencies: 1) The bar is too flexible, and we believe that additional stiffeners would not help substantially, since they could only extend approximately 6 ft from the driven end of the bar; 2) The chain design allows too little clearance for cuttings to meet the desired 12-ft/min traverse speed.

The Bowdil Company coal saw unit was judged conditionally acceptable for further consideration as a lock wall deicing machine. The major problem was the very short life of the main chain drive sprocket. This

would have to be corrected before the improvements suggested in the following paragraphs are considered.

The chain tightening mechanism used was taken from a suggested design by Bowdil Company. The long bolt intended to tighten the chain stripped in the field during the first attempt to tighten the chain. The chain was tightened with the bar in the horizontal position, which created a high tensile force in the chain due to the catenary effect (Fig. 11). If the bar is 15 ft long,  $x = 90$  in., the maximum desired sag  $y = 1$  in., and chain weight  $w$  is assumed to be 1 lbf/in., then the tension  $T$  can be calculated as:

$$T = wa \cosh z \quad (18)$$

where  $a = x/z =$  distance from lowest point of catenary to the directrix

$z =$  auxiliary variable

$$y/x = (\cosh z - 1)/z.$$

For this case,  $z = 0.02$ , so  $a = 4500$  and  $T = 4500$  lbf. The force on the bar required to achieve this tension is double the chain tension, or 9000 lbf. The tightening mechanism must overcome this force plus any additional friction forces between the bar and the crank arm. These frictional forces are unknown, but may be quite large due to large reaction forces between the keys on the bar and the crank arm, which are necessary to hold the bar horizontal. Some friction force can be eliminated by propping up the end of the bar when tightening the chain.

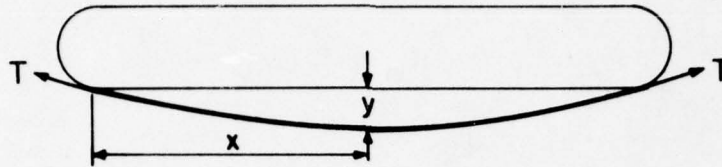

Figure 11. Chain tightening mechanism.

Chain forces of the magnitude required for 1-in. chain sag may also present problems in other areas. The outboard bearing has a radial load rating of 3370 lbf at 500 rev/min. Under static loading conditions, this loading can be increased to about 10,000 lbf without indenting the bearing raceway. The saw should not be operated for extended periods of time with the bar in the horizontal position or bearing damage may occur and life of the wearing shoe on the end of the bar would be limited.

When the bar is in the normal operating position of  $20^\circ$  off vertical the catenary effects are greatly diminished. The tension in the chain due to its own weight is then only slightly over 500 lbf, and this presents no problem.

One method of tightening the chain is to hang the bar vertically over the edge of the lock wall and tighten the bolts before raising the bar. This would require a modification to the lifting mechanism, to allow the bar to be moved into a vertical position. However, there is a possibility of getting the chain too tight and destroying the outboard shaft bearing.

Another method of tightening the chain, which appears to have more merit, is to hydraulically tension the chain with the bar hanging over the edge of the lock wall  $20^\circ$  off vertical. The tensioning mechanism would allow chain tension to be decreased when the bar is horizontal.

A dolly wheel to guide on the lock wall curbing, thus increasing vehicle stability, could possibly be incorporated into the jack mechanism for tensioning the chain. The adjustable feature of the dolly wheel would be quite attractive. However, the mounting position for the two purposes may be incompatible.

The desirability of higher chain speed is obvious. Cutting forces decrease for the same power input, and traverse rates increase accordingly. There may be overriding requirements with regard to chain, bar or sprocket design that would preclude further increasing chain speeds, and chain speeds may have to be decreased.

This should be coordinated with Bowdil Company. Changing chain speed is a simple matter of changing one of the drive sprockets.

A guide system for steering the tractor is desirable, since it is difficult for the operator to maintain the tractor at a given distance from the lock wall. This may not be as simple as it seems at first, since a positive guide would have to withstand high tire scuffing forces to maintain proper tractor attitude. Possibly a simple hydromechanical servo system could be incorporated to automatically steer the tractor through its power steering system. It may also be possible that strategically located pointers would provide adequate guidance for the operator to steer the tractor.

#### LITERATURE CITED

- Abel, J.F. (1961) Under-ice mining techniques. U.S. Army Snow, Ice and Permafrost Research Establishment (USA SIPRE) Technical Report 72. AD 652711.
- Brier, F.W. and K.D. Vaudrey (1975) Sea ice removal techniques for Winter Quarters Bay, Antarctica. U.S. Naval Civil Engineering Laboratory, Port Hueneme, Technical Note N-1416.
- Mellor, M. (1975) Mechanics of cutting and boring. Part I: Kinematics of transverse rotation machines. U.S. Army Cold Regions Research and Engineering Laboratory (USA CRREL) Special Report 226. AD A010634.
- Mellor, M. (1976) Mechanics of cutting and boring. Part III: Kinematics of continuous belt machines. CRREL Report 76-17.
- Mellor, M. (In prep.) Mechanics of cutting and boring. Part IV: Dynamics and energetics of parallel motion tools. CRREL Report.
- Vaudrey, K.D. (1975) Development of an ice excavation machine. U.S. Naval Civil Engineering Laboratory, Port Hueneme, Technical Note N-1415.

## TERMINOLOGY

*Esplanade* – The level, unobstructed area next to the lock walls suitable for driving vehicles and equipment along the locks. A fabricated steel curbing approximately 8 in. high borders the lock side of the esplanade.

*Included angle* – The angle between the leading face and the relief face of the cutter.

*High pool elevation* – The water level within the lock walls when it is the same level as the water in the canals upstream of the lock.

*Overbreak* – A cutting tool working in brittle material excavates a groove that extends beyond the limits of the area swept by the cross section of the tool. The difference between the total groove volume and the volume swept out by the tool itself is called overbreak.

*Rake angle of cutter* – The angle between the leading face of the cutter and a normal to the cut surface at the cutting edge.

*Relief angle or clearance angle* – The angle between the flank or relief face of the cutter and the tangent to the cut surface at the cutting edge.

## CONVERSION FACTORS: U.S. CUSTOMARY TO METRIC (SI) UNITS OF MEASUREMENT

These conversion factors include all the significant digits given in the conversion tables in the ASTM *Metric Practice Guide* (E 380), which has been approved for use by the Department of Defense. Converted values should be rounded to have the same precision as the original (see E 380).

<i>Multiply</i>	<i>By</i>	<i>To obtain</i>
inch	25.4*	millimeter
foot	0.3048*	meter
inch/minute	0.4233333	millimeter/second
foot/minute	0.00508*	meter/second
foot/hour	0.3048*	meter/hour
degree	0.01745329	radian
revolution/minute	0.1047	radian/second
pound force	4.448222	newton
pound force/inch <sup>2</sup>	6894.757	pascal
pound force/foot <sup>2</sup>	47.88026	pascal
horsepower	745.6999	watt

\* Exact.

LABORATORY EXPERIMENTS ON LOCK WALL DEICING USING  
PNEUMATIC DEVICES\*

by

K. Itagaki, M. Frank, S.F. Ackley

Introduction

Winter navigation of the rivers and lakes of northern America suffers from multiple problem areas. One major problem encountered is ice build-up in the lock areas. Ice accumulation on the lock walls reduces the effective size of the locks, thus reducing the size of ships allowed through.

This build-up occurs because of two major factors. First, the ice from upstream is brought in with ships during the locking process. This ice is crushed against the walls and gates by the moving vessel. In subfreezing air temperatures the ice will freeze on the walls and remain. This build-up is very rapid; for example, one foot of ice can accumulate during a single ship passage.

The second factor is due to the rise and fall of water levels during lock operations in subfreezing air temperatures. Each time the level is changed, some water remains and freezes to the wall. The accumulation is a function of the number of lock operations as well as the air and water temperature and is relatively slow compared to that of the crushing of ice on the wall, but over a period of time this accumulation may also become a serious problem.

---

\*USACRREL Technical Note, October 1975

This note describes some of the laboratory experiments which were conducted to examine the feasibility of using pneumatic devices for removal of ice build-up of lock walls and gates.

### Deicers

Since inflatable deicers were successful on radomes (Ackley, et al. 1973), this method was again utilized. Inflatable devices offer several advantages to other methods, some of which are: a readily available driving media (compressed air), which is already installed at most sites, standard fabrication processes, high strength and durability, and relatively low overall system cost. The energy required to crack ice is so much lower than to melt even a very thin layer (Ackley et al. 1973) that expected operational costs could also be expected to be lower than a heating system. In the application of this concept to lock walls and gates, two problems which had to be considered were the ability of the deicer to remove thick accumulated ice and the durability of the deicer to withstand the forces ships could place on it either directly or indirectly through the crushing ice.

Although more complex conditions may control the effectiveness under real conditions, calculations on the forces required for ice separation or fracture based on the following assumptions and criteria for the transition give us some insight of the process of ice removal on this system.

Let us assume that the deicer is a pair of rigid plates hinged at both ends and can be opened slightly by some means such as the pneumatic method. Dependent upon the thickness of the ice built up on the plate,

three modes of ice removal can be identified as shown schematically in Figure 1a, b and c, where the force required for ice removal and the transition points can be calculated using the equations shown in the figure. Assuming the various strengths of ice and the adhesive strength of the ice-steel system:

- a. Ice is thin so that it is fractured at the hinges, but little ice is removed.
- b. Ice will be fractured in the intermediate thickness range, then separated by shear action.
- c. Ice cannot be broken when it is thick, but simply separated from the plate by tensile force aided by peeling action.

The transition from mode a to mode b would occur at the ice thickness  $.1375 \times \ell$  (where  $\ell \approx 30$  cm in the present case) so that ice would begin to be sheared off when its thickness exceeds 4.125 cm = 1.6 inches. The transition from mode b to mode c would occur at  $1.18 \ell = 35.4$  cm = 14 inches. Our experiences indicate that this estimation reasonably predicted these transitions. The force required for separation in case b, however, is several times smaller than the calculated value. Probably uneven stresses applied on the ice panel interface due to uneven thickness of ice caused initiation of a crack at the edge of the ice, and then the crack spread with a very small supply of energy.

#### Laboratory Deicers

Several test models were constructed using three basic designs. The first design (Model I) was a variation of a previously developed deicer used

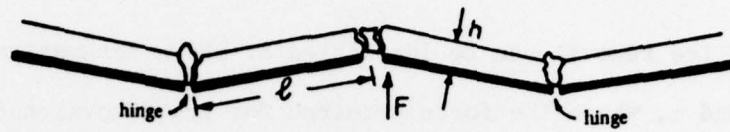

$$F = \frac{h^2}{l} dT$$

where  $h$  = ice thickness

$T$  = tensile strength of ice  
(25 kg/cm<sup>2</sup>)

$C$  = compressive strength of ice  
(40 kg/cm<sup>2</sup>)

$d$  = width of ice accumulation  
(not shown in this view)

$S_s$  = shear adhesive strength  
(5.5 kg/cm<sup>2</sup>)

Transition

$$a \rightarrow b = h > l \frac{S_s}{C} = 0.1375l$$

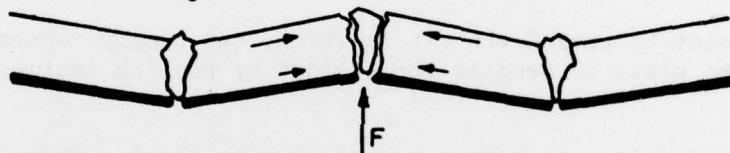

$$F = 2hdS_s$$

Transition

$b \rightarrow c$

$$\text{either } h > l \frac{T_{ad}}{S_s} = 6.36l$$

$$\text{or } h > l \sqrt{\frac{T_{ad}}{T}} = 1.18l$$

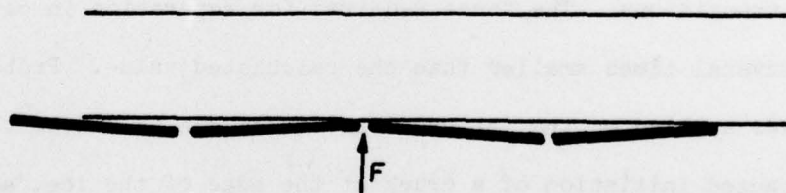

$$F = 2ldT_{ad}$$

$T_{ad}$  = tensile adhesive strength  
(35 kg/cm<sup>2</sup>)

Figure 1. Model of ice removal from an inflatable pneumatic device as a function of thickness (a) thin ice (b) intermediate thickness (c) thick ice.

on radomes. It consisted of a flattened polyurethane tube imbedded in a poured rubber block, which in turn was enclosed between two .030 in. sheets of polyurethane film. Figure 2 shows the deicer under construction and fully assembled. As air was forced into the deicer, the tubing expanded, moving the outer surface, causing the fracturing of ice.

The second design allowed for greater expansion of the deicing surface and provided some resistance to the heavy abrasion likely from vessels in the locks. Three models of this design were constructed and tested. These differed only in the outside surface material, one being aluminum (Model II), one steel (Model III), and one fiberglass epoxy (Model IV). Figure 3 shows one of these models before pouring the rubber. The hose is of the type used as fire hose. A layer of 20 gauge galvanized steel with a pleat in the center of the sheet metal to give the needed expansion (Figure 4) was attached to steel pipe supports at both sides. The armor surfaces of aluminum or steel were then attached to the sheet metal by rivets. The fiberglass-epoxy armor surface of 1/4 in. was built on a thinner sheet to permit required flexibility. The rubber was then cast to a thickness of 1-1/2 in. to 2 in.

The third deicer model (Model V) consisted of sections of the flat hose attached along the wall. It was hoped that fracturing would produce cracks that would propagate along the ice-wall interface and cause removal. This deicer is shown in Figure 5.

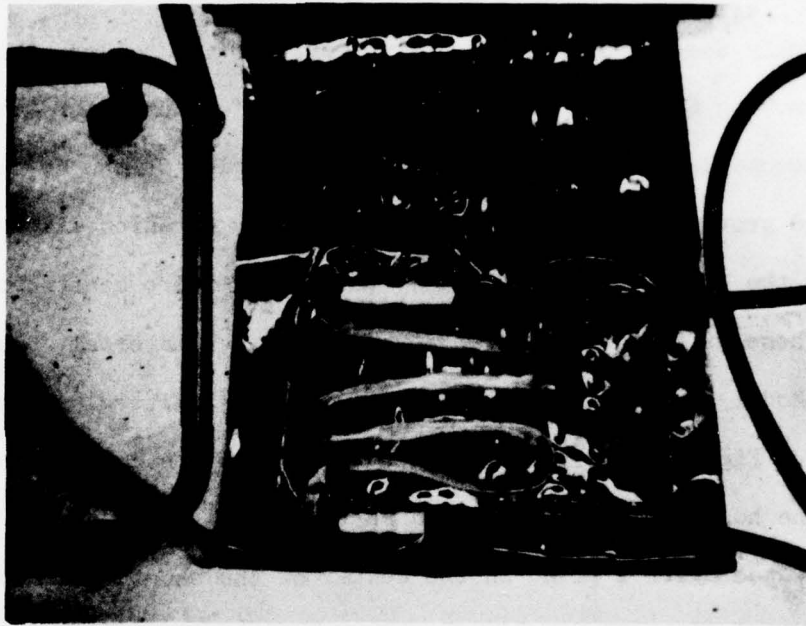

Figure 2. Model I deicer under construction. This deicer consisted of the flattened polyurethane tube shown imbedded in poured rubber and sandwiched between two sheets of polyurethane film.

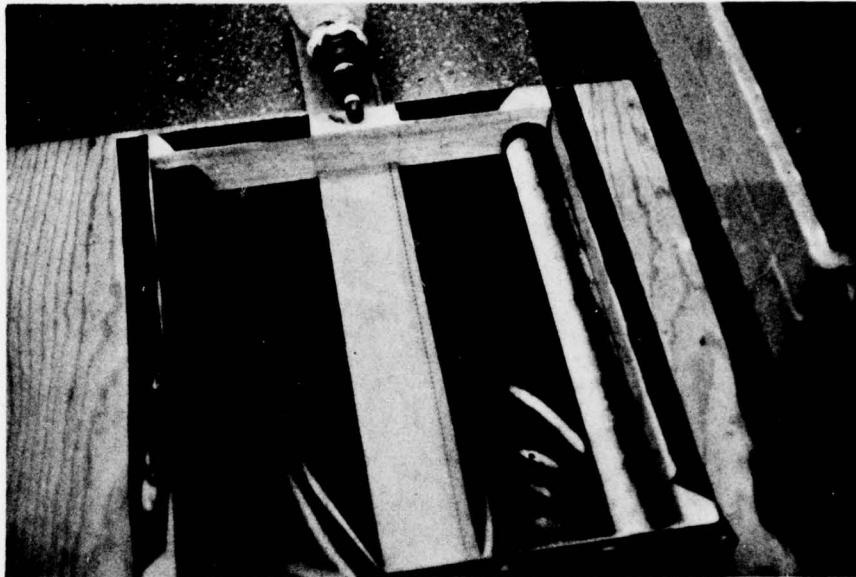

Figure 3. Model II, III, or IV deicer under construction. This deicer used a section of fire hose as the inflation portion of the deicer and was protected by an outer surface of aluminum, steel, or epoxy-fiberglass.

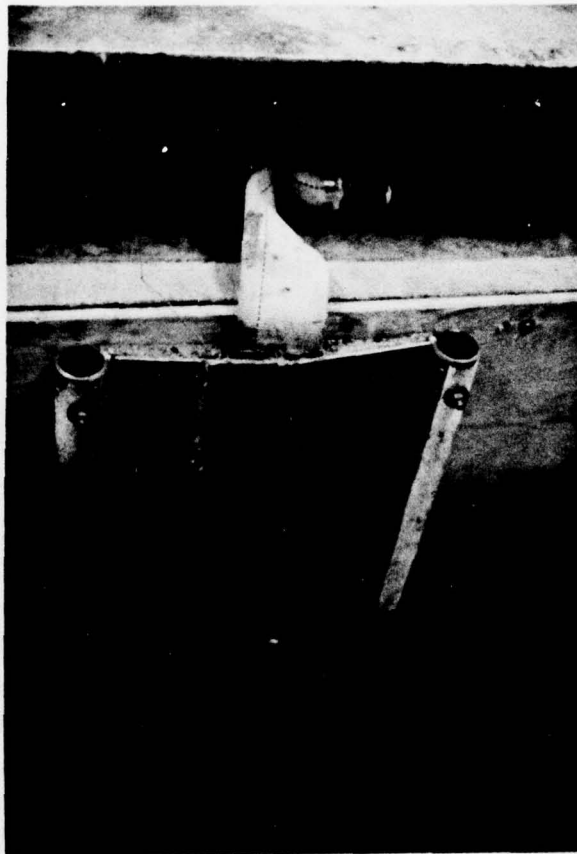

Figure 4. Model II deicer installed in the cold pit area by attaching to steel pipes mounted on the lockwall simulator.



Figure 5. Model V deicer, a fire hose section, mounted in the lockwall simulator. The broken ice is indicated in the center foreground.

### Simulations of Lock Operation

A small scale simulator was constructed for the initial testing period. The device raised and lowered the test deicer from a water bath in a cold room environment kept at  $-10^{\circ}\text{C}$ . The water was kept above freezing by a heater. Approximately 5 minutes was required to raise and lower the deicer. Several days were required to accumulate two or three inches of ice. This device was used only for the initial phase of the experiment, since large ice accumulations formed bridges to the supporting structures and prevented the operation of the simulator so that an accurate appraisal of the deicer was not possible.

A larger simulator was constructed in the flooded cold pit area of USACRREL to allow more room for testing and to give a more accurate picture of the conditions encountered in real situations. A schematic and photograph of this simulator are shown in Figure 6 and 7. The tank was made of reinforced concrete and had the following dimensions: depth, 4 ft, width, 4 ft, length, 8 ft. A timer operated pump-valve system controlled the water flow to and from the tank changing the water level cyclically. The water level was changed by about 18 in. in 20 minutes. This cyclic raising and lowering simulated lock action. The filling rate could be varied to give the effects of more lockages. Air, water and deicer surface temperatures were recorded on a 1-pen L&N Speedomax recorder using a cam-driven switching device.

Ice was allowed to form on the surfaces of the deicers, which were mounted on one side of the simulator, such that their halfway points were approximately at the high water mark. Ice up to 9 inches thick was obtained after a few days. The air temperature in the pit was kept at  $-10^{\circ}\text{C}$ .

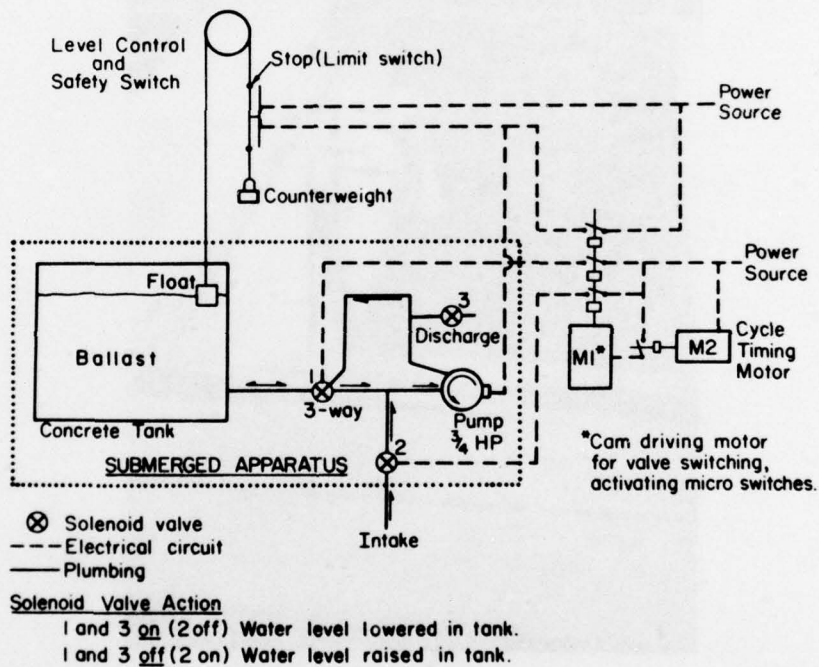

Figure 6. Schematic of the lockwall simulator used in the lockwall laboratory experiments.

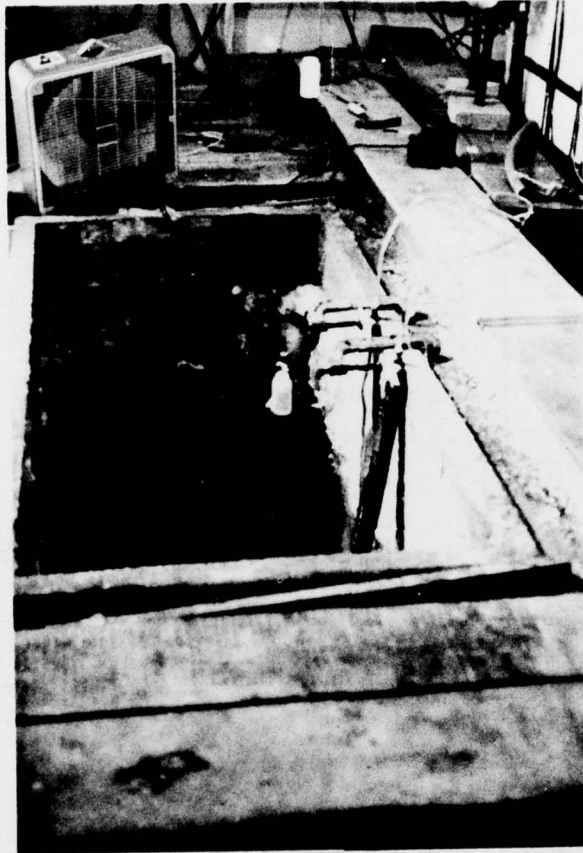

Figure 7. Photograph of the lockwall simulator installed in the cold pit.

## Results

Model I was tested in the first simulator, and although test conditions were not ideal, a rough evaluation of required expansion was possible. Ice was effectively removed when thickness was below three inches. Above three inches, bridging to the support structure prevented ice removal due to the limited expansion of the outer surface. This was also tested in the second simulator with about the same results.

Tests on the second design (Models II-IV), Figure 3 were conducted entirely in the second simulator. This design proved to be the most successful series. During inflation of the deicer, the ice developed multiple cracks, the primary one causing the parting at or near the ice-deicer interface. Once the cracks were spread, the ice shed in a single piece. Tests indicated that the development of this fracture was a function of the distance of the center portion of the deicer panel moved outward by the inflating air hose. With the four inch diameter air hose used here, buildups of over 9 in. were easily removed.

Some difficulties were encountered during prolonged operation when the simulator essentially froze completely over and thick ice (8 to 10 inches deep) bridged to the other side of the wall. This caused approximately 9 to 12 in. thick ice on the surface of the deicer which also bridged to the other sides of the tank. Under these conditions, the movement of the deicer was restricted and, although fractures developed, ice could not be removed. When the restriction was removed at the corners of the tank, as in a real lock structure, ice of up to a foot thick could be removed in less than five inflation cycles.

The third design (Fig. 5) indicated some capability for ice removal in the immediate areas, but could not develop fractures throughout the space between the hoses. Ice of more than 4 inches thick was not successfully removed.

#### Conclusion

It was found that the second design consisting of the flattened 4 in. hose in a poured rubber block and armored with a hard outer surface, was very effective in removing ice accumulations up to a foot in thickness. This ice thickness was considered to be a reasonably accurate representation of that found to occur in the locks due to raising and lowering of the water level during operations in sub-freezing air temperatures. The tests also showed that efforts to protect the surface of the deicer using various types of armor and the use of heavy duty hose to expand the apparatus did not reduce the capability of the deicer to operate. In fact, most ice accumulations were removed after a single inflation.

Based on these preliminary results, a large scale test model was fabricated and installed in the St. Marys River Canal System, Sault Ste. Marie, MI. A schematic and a photograph of this system are shown in Figure 8. The photograph in Figure 8 graphically illustrates the ability of the deicer to remove ice when installed. A full description of the field-tests will be the subject of another report. Questions still to be resolved in field tests are the ability of the deicer to cope with ice pressed against the walls by ships, and the abrasive effects of ship and ice action on the deicer during prolonged operation. The boots systems described here can successfully remove ice both in laboratory and field situations.

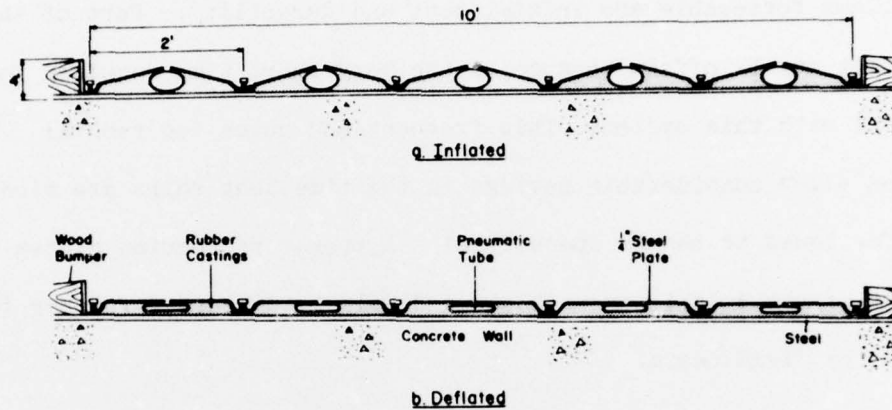
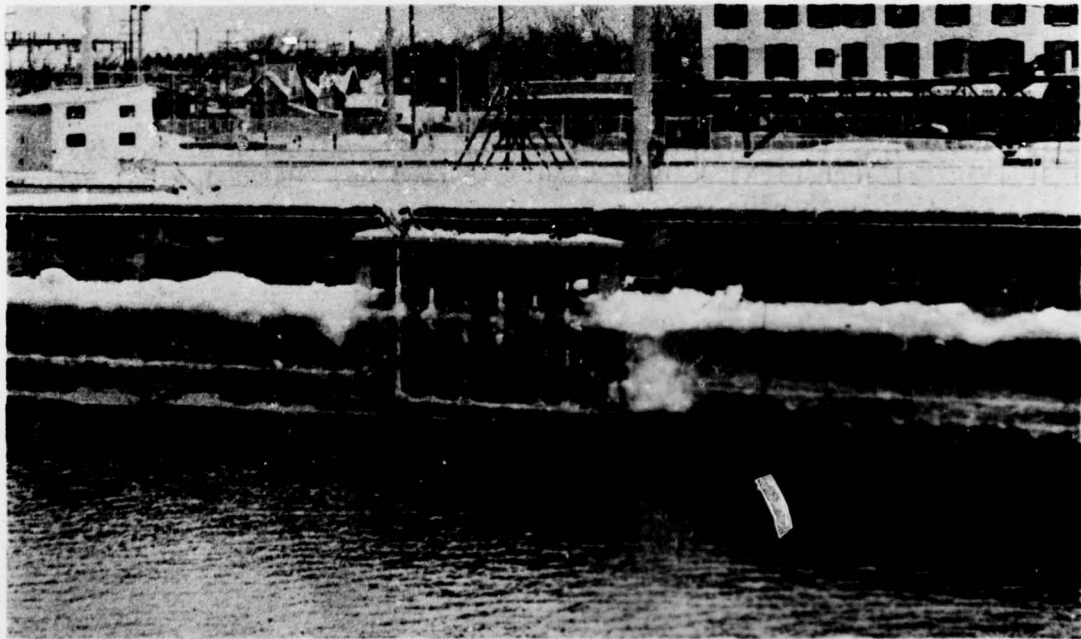

Figure 8. (a) Schematic of the lockwall deicer installed for field testing at Sault Ste. Marie, Mich.



(b) Photograph of the lockwall deicer installed at Sault Ste. Marie. The ice removed in the region of the deicer is already shown. This ice usually was removed within, at most, three or four inflations of the system.

Problems foreseeable are initial cost and durability. Part of the initial cost may be offset because of the very short time required for ice removal with this system. This frequent and quick ice removal would then allow considerable savings in the time that ships are tied up waiting for locks to become operational. A proper protection system would solve part of the durability problems and will be discussed further in the report on the field tests.

#### Acknowledgement

This work was supported by Civil Works, Corps of Engineers. Thanks to Mr. G. Frankenstein and L. Zabilansky of USACRREL for their assistance during the laboratory phase of this program.

#### Reference

Ackley, S.F., K. Itagaki, M. Frank, (1973). An evaluation of Passive Deicing, Mechanical Deicing and Ice Detection, USACRREL Final Report to the FAA, FAA-RD-74-50.