

AD-A044 989

CATHOLIC UNIV OF AMERICA WASHINGTON D C INST OF OCEA--ETC F/6 17/1
A SYSTEM DESIGN FOR ACCURATE MEASUREMENT OF THE TIME OF AN ACOU--ETC(U)
OCT 69 J D SHERMAN
NONR-2249(14)

UNCLASSIFIED

69-7

NL

| OF |
AD
A044989

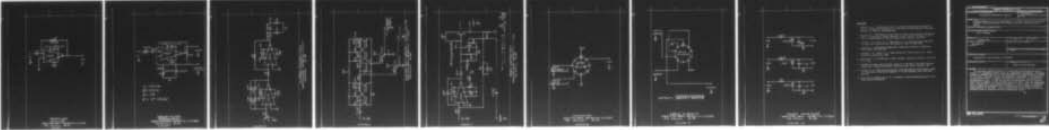

END
DATE
FILMED
11 -77
DDC

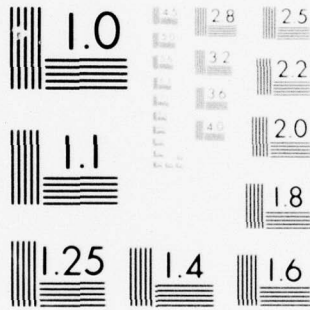

MICROCOPY RESOLUTION TEST CHART
 NATIONAL BUREAU OF STANDARDS-1963-A

ADA 044989

000358

DDC FILE COPY

to find

OOV LIBRARY COPY

→ E 4 R **THE MOST Project -3**

A SYSTEM DESIGN FOR ACCURATE MEASUREMENT OF THE TIME OF AN ACOUSTIC PULSE FOR A SHIP POSITIONING AND TRACKING SYSTEM--OVER--THE--PEAK DETECTION SYSTEM

(1)

B.S.

by

JOHN D. SHERMAN

*OOVIB
1M5385
CPS
OOVIB
1M5388
Library*

DEPARTMENT OF ELECTRICAL ENGINEERING

Report *69-7*

COOPERATIVE PROGRAM IN OCEAN ENGINEERING

ONR 2249(14)

OCTOBER 1969

DDC
RECEIVED
OCT 12 1977
RECEIVED
A

Institute of Ocean Science and Engineering
The Catholic University of America
Washington, D. C. 20017



DISTRIBUTION STATEMENT A

Approved for public release;
Distribution Unlimited

25-14

per project
mkt

②

A SYSTEM DESIGN FOR ACCURATE MEASUREMENT
OF THE TIME OF ARRIVAL OF AN ACOUSTIC
PULSE FOR A SHIP POSITIONING AND TRACKING
SYSTEM--OVER--THE--PEAK DETECTION SYSTEM,

by

⑩ John D. Sherman

Office of Naval Research Code 466

⑮ Non-
Contract 2249(14)

⑭ 69-7

⑫ 22p.

⑪ October 1969

⑨ Final Report,

D D C
RECEIVED
OCT 12 1977
A

Institute of Ocean Engineering
The Catholic University of America
Washington, D. C. 20017

Distribution of this document is unlimited

404 847

JB

ABSTRACT

An electronic design disclosure of a system which establishes the time of arrival of a rectangular acoustic pulse at a hydrophone is presented. The system attempts to minimize the error in the measurement of the time of arrival, as well as to provide a technique to make this measurement independent of the amplitude of the received pulse. To improve the signal-to-noise ratio, a matched filter approximation is used. To make the arrival time measurement when the signal-to-noise ratio is maximum, an over-the-peak detector is used. Since the measurement uses a characteristic of the signal equivalent to a slope change, the amplitude does not affect the measurement as it currently does on the present threshold system employed on the Mizar. A major consideration in the design was that the proposed system be compatible with the present Mizar system.

ACCESSION for	
KTIC	White Section <input checked="" type="checkbox"/>
DOC	Dist. Section <input type="checkbox"/>
UNANNOUNCED	<input type="checkbox"/>
JUSTIFICATION.....	
BY.....	
DISTRIBUTION/AVAILABILITY CODES	
Dist.	AVAIL. and/or SPECIAL
A	

INTRODUCTION

The need for accurate measurement of the time delay between the arrival of an acoustic signal for a short base navigation system has been established by F. Andrews (1). Several techniques for performing this measurement were discussed by E. Magrab (2). The system presently employed on the U.S.N.S. Mizar is described by H. Van Ness, R. Mills and K. Stewart (3), although some minor changes have taken place since their report.

In an attempt to use all the energy contained in a rectangular acoustic pulse, a matched filter can be used to optimize the peak signal to RMS noise ratio. After the signal emerges from the matched filter a specific point on the waveform must be used to establish the time of arrival of the pulse. The logical point on the output waveform to use for this purpose is the peak.

There follows a description of an electronic system which accomplishes this function using two approximations. One approximation is the use of an active filter (equivalent to a resonant "tank" circuit) which is used in place of a true matched filter. When the Q of this circuit is properly matched to the width, this approximation produces an output signal-to-noise ratio only one db worse than the true matched filter (4,5). The second approximation involves the choice of the point on the waveform out of the matched filter that will be used to establish the time of arrival of the pulse-ideally the peak. However, only after a delay can one say that the peak has occurred. In this system the delay is one cycle of the carrier frequency which introduces insignificant error since it occurs so close to the peak. The time of arrival is thus defined by determining when the output of the matched filter goes over-the-peak, and hence, this system is called an "Over-the-Peak Detection System".

SYSTEM DESCRIPTION

Fig. 1 is the block diagram of the system and Fig. 2 is a representation of the voltage waveforms at the points indicated on the block diagram. The timing of these waveforms is to scale, the amplitude is not. Point A is the input of a rectangular pulse of sine wave of frequency $f_0 = \omega_0/2\pi$ Hz, and of duration T seconds. The input signal is given by

$$e_A = E_M \sin \omega_0 t [u(t) - u(t-T)]$$

Taking the Laplace transform of the above gives

$$E_A(S) = \frac{E_M \omega_0}{S^2 + \omega_0^2} [1 - e^{-ST}]$$

provided $T = n2\pi/\omega_0$, where n is an integer (this is not a necessity but the expression is less cumbersome if it holds).

This signal passes through an inverting preamplifier and then through an active filter with a transfer function

$$H(S) = \frac{-H \omega_0 S}{S^2 + \alpha \omega_0 S + \omega_0^2}$$

where ω_0 is made the ω_0 of the signal, $H = \alpha A_0$ (A_0 is the gain at ω_0) and $\alpha = \frac{1}{Q} = \frac{\Delta\omega}{\omega_0}$ where $\Delta\omega$ is the -3db bandwidth). In order for this filter to closely approximate a matched filter (to get the largest signal to noise ratio) it is necessary that (4)

$$T = \frac{0.4 Q}{f_0}$$

Eight cycles of the carrier are used in Fig. 2. If this is the case, and if $f_0 = 10$ kHz,

$$Q = \frac{T f_0}{0.4} = \frac{(8/f_0) f_0}{0.4} = 20$$

This is a pulse of duration $T = 8/f_0 = 0.8$ ms. Although this pulse is very short, the fact that a low Q circuit may be used makes the matching of three active filters for the three channels relatively easy (since the measurement is essentially that of a phase angle, high Q circuits would have to be matched very closely). Also roll and pitch errors will be smaller. In addition, it can be shown (4) for matched filter detection, with high input signal-to-noise ratios, the standard deviation in the time of occurrence of the peak is given by

$$\sigma_T = \frac{1}{2\pi \Delta f \sqrt{2E/N_0}}$$

the quantity Δf is the effective bandwidth of the signal (not the 3db bandwidth (6)) and in the case of a rectangular pulsed carrier is equal to $2/T$. The quantity $2E/N_0$ is the peak signal to RMS noise power ratio out of the matched filter (E is signal energy and $N_0/2$ is the noise power spectral density), in this case:

$$(S/N)_{MF_{PR}} = \frac{2E}{N_0} = \frac{E_m^2 T}{N_0}$$

Thus,

$$\sigma_T = \frac{T}{4\pi \sqrt{\frac{E_m^2 T}{N_0}}} = \frac{\sqrt{T N_0}}{4\pi E_m}$$

Hence, the standard deviation of the arrival time varies directly as \sqrt{T} and inversely with the voltage amplitude of the sine wave. If the energy were able to be held constant, the standard deviation would vary directly with T . It is difficult to hold the energy of the pulse constant as the pulse length is decreased. But even if the the energy cannot be held constant, one is still better off with a shorter pulse (provided the input signal-to-noise ratio is high).

The expression for the standard deviation may also be written in terms of the input signal-to-noise ratio:

$$\sigma_{\gamma} = \frac{T}{B \pi \sqrt{(S/N)_{IN}}}$$

In the case demonstrated, if a 20 db input signal-to-noise ratio is assumed (this may be difficult with such a narrow pulse, but it is possible), then:

$$\sigma_{\gamma} = \frac{0.8 \times 10^{-3}}{8 \pi \cdot 10} = 3.184 \mu s$$

It should be noted that the active filter built as a prototype at The Catholic University of America, has a Q of 50, thus requiring $T = 2$ ms or 20 cycles of a 10 kHz signal. Then, if $(S/N)_{IN}$ is 20 db, $\sigma_{\gamma} = 8 \mu s$.

Referring again to Figs. 1 and 2, the output of the filter, point B, is the input to three circuits. One of these circuits clips the signal and differentiates it forming an output signal consisting of negative spikes, point C, provided the input exceeds a threshold. These spikes trigger a one shot multivibrator producing output pulses at point D. The negative going transition of these pulses triggers a second one shot whose output appears at point E.

The output of the filter also goes to two inverting peak detectors. One peak detector holds the peak value of each of the positive half cycles of its input, being "updated" every time a new peak is greater than the preceeding peak. When the "peak-peak" is reached (the last positive peak prior to time T), this peak detector holds this value since succeeding peaks are lower in amplitude. This output is point F.

The other peak-detector also holds the peak value of each of the positive half cycles except that its output is reset to zero by the pulses at E. This output is

is point G.

The signals at F and G are compared in a comparator circuit whose output appears at H. Note that when the voltage at F is greater than the voltage at G, the comparator output is a logical "one".

The comparator output, H, is "ANDed" with the pulses at D producing the final output at I. Note that this output consists of positive pulses which begin exactly $1 \frac{1}{4}$ cycles after the occurrence of the largest positive half cycle out of the matched filter.

DESCRIPTION OF SYSTEM BLOCKS

Preamplifier

The preamplifier circuit, shown in Fig. 3, consists of a standard inverting amplifier using the National LM201 monolithic operational amplifier. The gain is adjustable from zero to 20. The input impedance is 10 kohms and the output impedance is 150 ohms. The current drain is about 1.5ma from the power supply.

Matched Filter Approximation

The filter, shown in Fig. 4, is the ideal current-inversion negative-immittance converter (INIC) type of active band pass filter described by Burr-Brown (7). The filter must be driven from a low impedance source if it is not to be affected by the source impedance. The center frequency and bandwidth are established by setting the pots shown in the figure. The Q of the circuit was adjusted to 50 giving a gain at 10 kHz of 1000. The use of potentiometers in the positions shown will allow three filters to be precisely matched. The current drain is about 1.5ma. The transfer function has been given previously. It should be noted that the output was taken from pin b on the LM201 (marked "output #1") rather than at the point called for by Burr-Brown (7). This provided higher gain and a lower output impedance.

Clipper-Differentiator

This circuit, shown in Fig. 5, amplifies and clips the input and then differentiates the resulting square wave. The negative pulses are present at the output. These negative pulses will occur whenever the input waveform crosses from plus to minus. Note that following the clipper is a unit gain amplifier. This is necessary to invert the phase of the signal out of the clipper stage so that the resulting signal is in phase with the input. The total current drain is about 3ma. The pot at the input adjusts the minimum threshold level.

Timing Circuit

The two one-shot multivibrators, which comprise the timing circuit shown in Fig. 6, each produce an output pulse that is about 5 microseconds long. The output of the first one-shot goes from 0 to 5 volts and occurs upon the arrival of the negative spike from the clipper-differentiator. This pulse is buffered in an emitter follower whose output goes to the logic input. The negative transition of the pulse from the first one-shot is used to trigger the second one-shot. The output from the second one-shot is taken from the side which goes from 12 to 0 volts. This pulse is used to reset one of the peak detectors. This circuit draws about 20ma from the supply.

Peak Detector

The two peak detectors are identical except for a different feedback capacitor and resistance as noted on Fig. 7. The circuit uses the operational amplifier to make the diode (IN251) look like an ideal diode and uses the FET to allow very long storage times (8). This long storage time was not needed for this application so that a resistor was added in parallel to the holding capacitor to allow it to discharge faster. The 2N964 is used to completely discharge the capacitor when a reset pulse comes in. The circuit draws about 2ma from the supplies.

Comparator

The Fairchild 1710 is used to compare the outputs of the two peak detectors. This integrated comparator is shown in Fig. 8. It draws about 8ma from each supply.

Logic Circuit

The logic, Fig. 9, is a Signetics SE113K dual NAND gate. The outputs of the first one-shot and the comparator are first "NANDed" and this output is inverted for an overall effect of an AND gate. The circuit draws about 12ma from the supply.

Power Conditioner

A well regulated ± 15 Vdc power supply (Hewlet Packard Model 60155c) provides power for the system. Several other voltages are required with very low current requirements. Fig. 10 shows how these voltages are derived from the ± 15 V supply using simple zener regulators.

CONCLUSION

The system as described was tested with white noise added to the signal. The results seem to indicate that the system gives the correct answer at least 90% of the time with a signal-to-noise ratio of 20db. Two identical systems will be built by the Naval Research Laboratory in November of 1969 and more extensive measurements will be made.

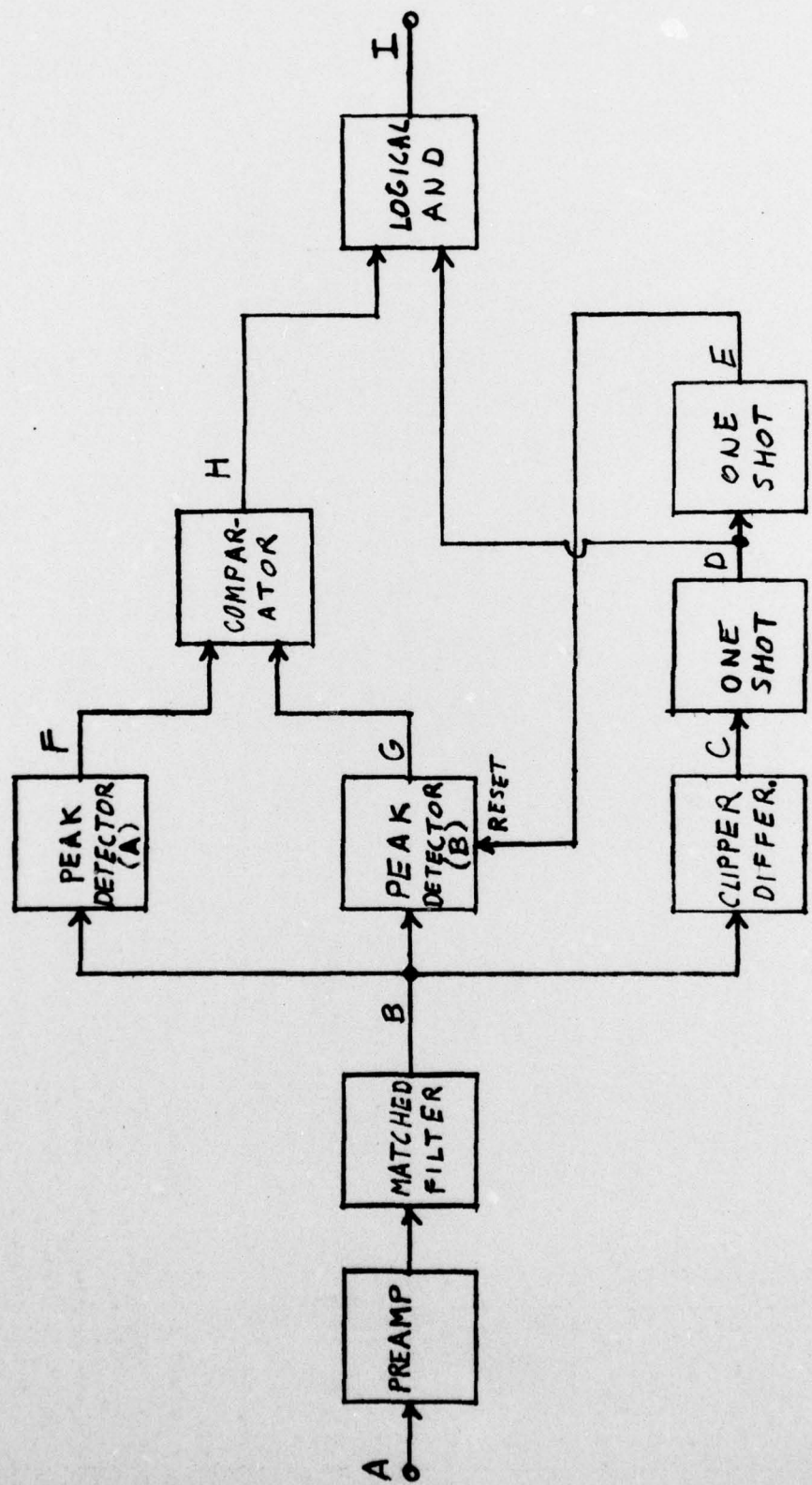

BLOCK DIAGRAM III
 OVER-THE-PEAK DETECTION SYSTEM
 T. D. Sherman 8-69

FIGURE 1

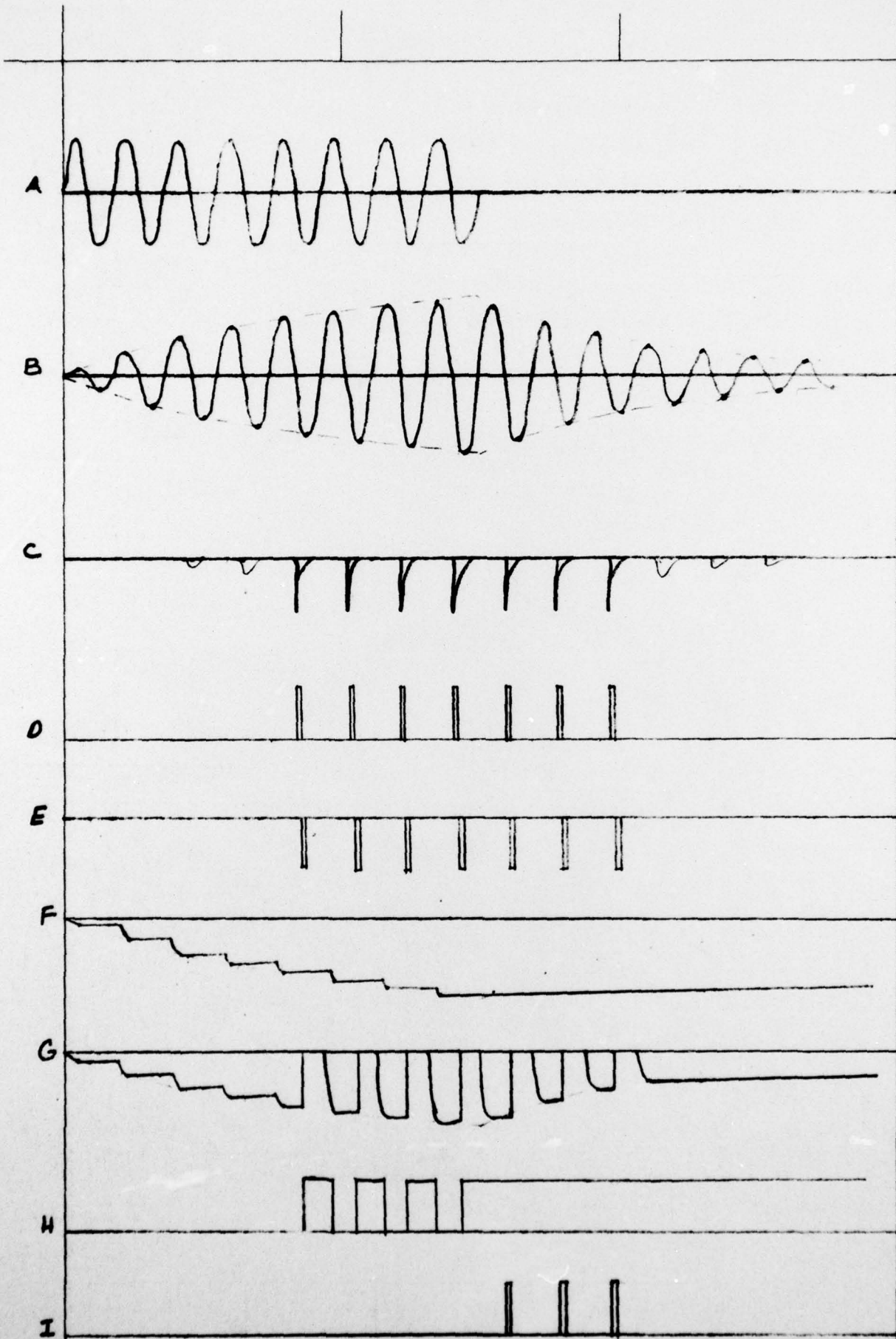

WAVE FORMS
 OVER-THE-PEAK DETECTION SYSTEM
 J. D. Sherman B-67

FIGURE 2

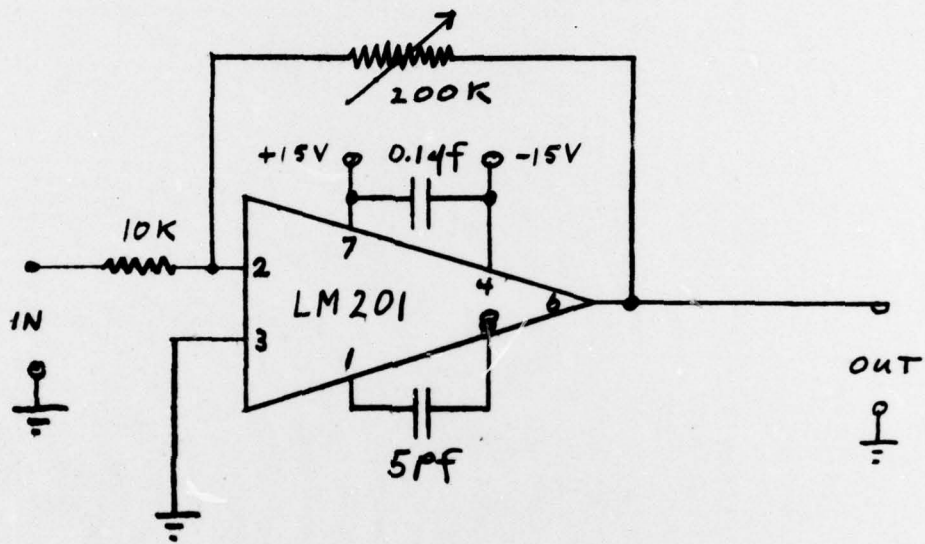

PREAMPLIFIER
 (OCLA 20)
 OVER-THE-PEAK DETECTION SYSTEM
 F.O. Sherman 8-69
 FIGURE 3

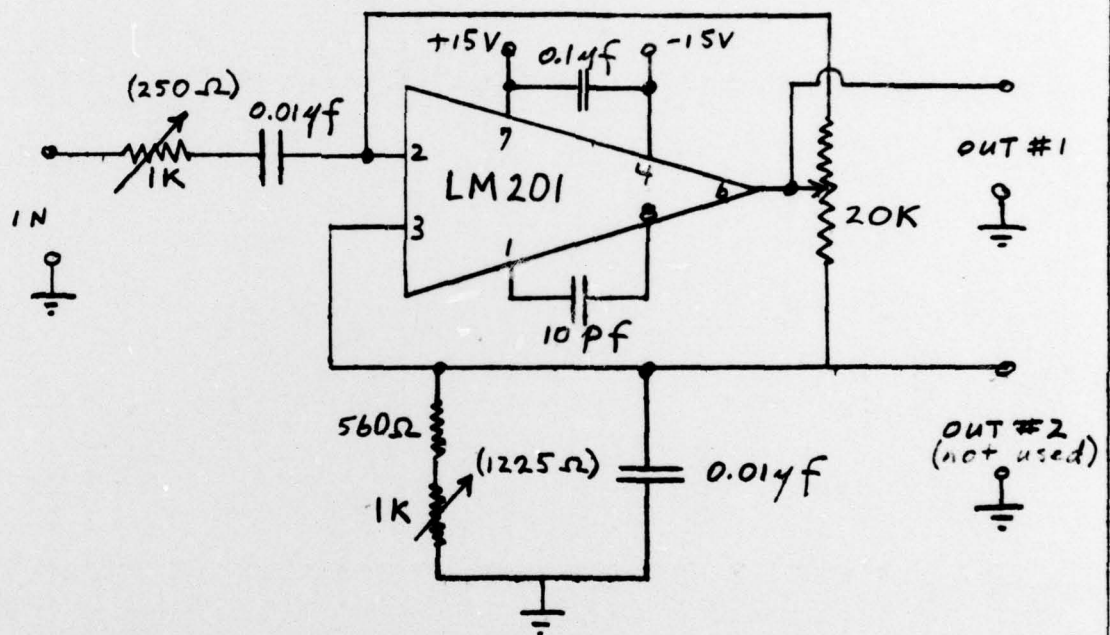

$f_0 = 10.00\text{ kHz}$
 $\Delta f = 200\text{ Hz}$
 $Q = 50$
 $A = 10^3\text{ (60 dB)}$

**MATCHED FILTER
 (APPROXIMATION)
 OVER-THE-PEAK DETECTION SYSTEM**
 J.D Sherman 8-69
 FIGURE 4

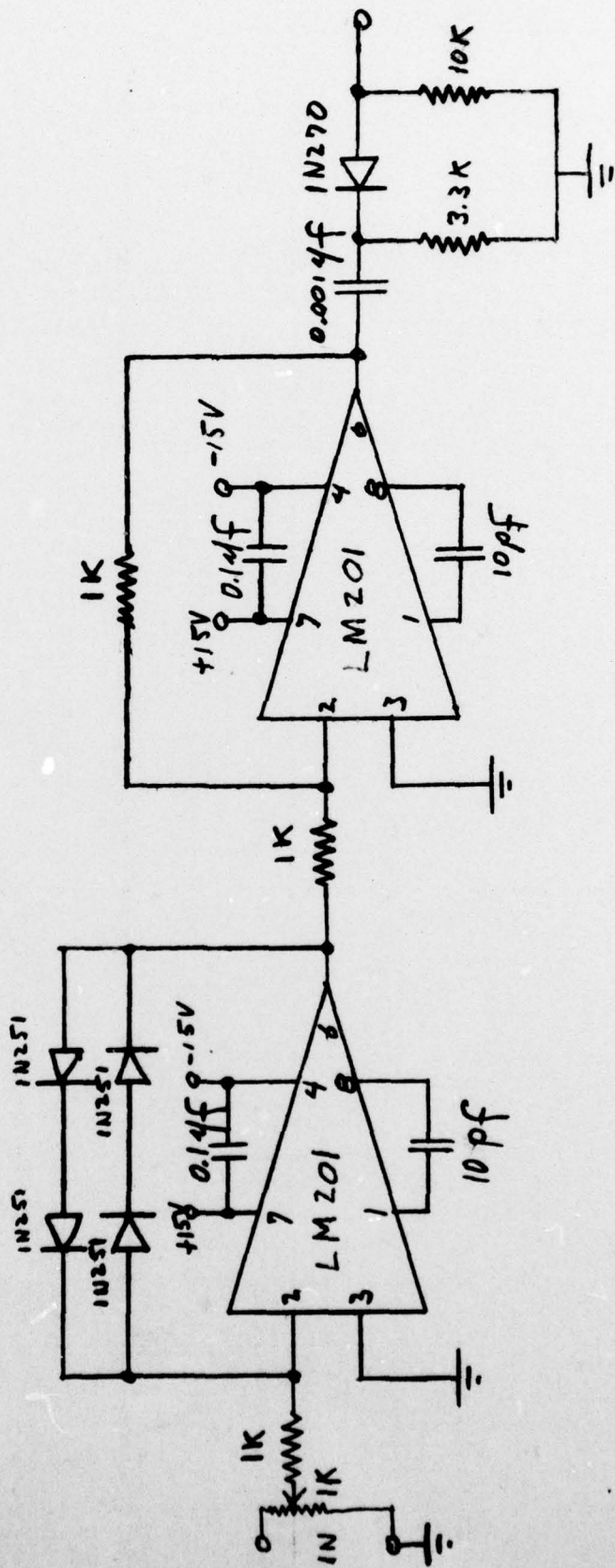

FIGURE 5

CLIPPER-DIFFERENTIATOR
 OVER-THE-PEAK DETECTION SYSTEM
 T.D. SHORNER 8-69

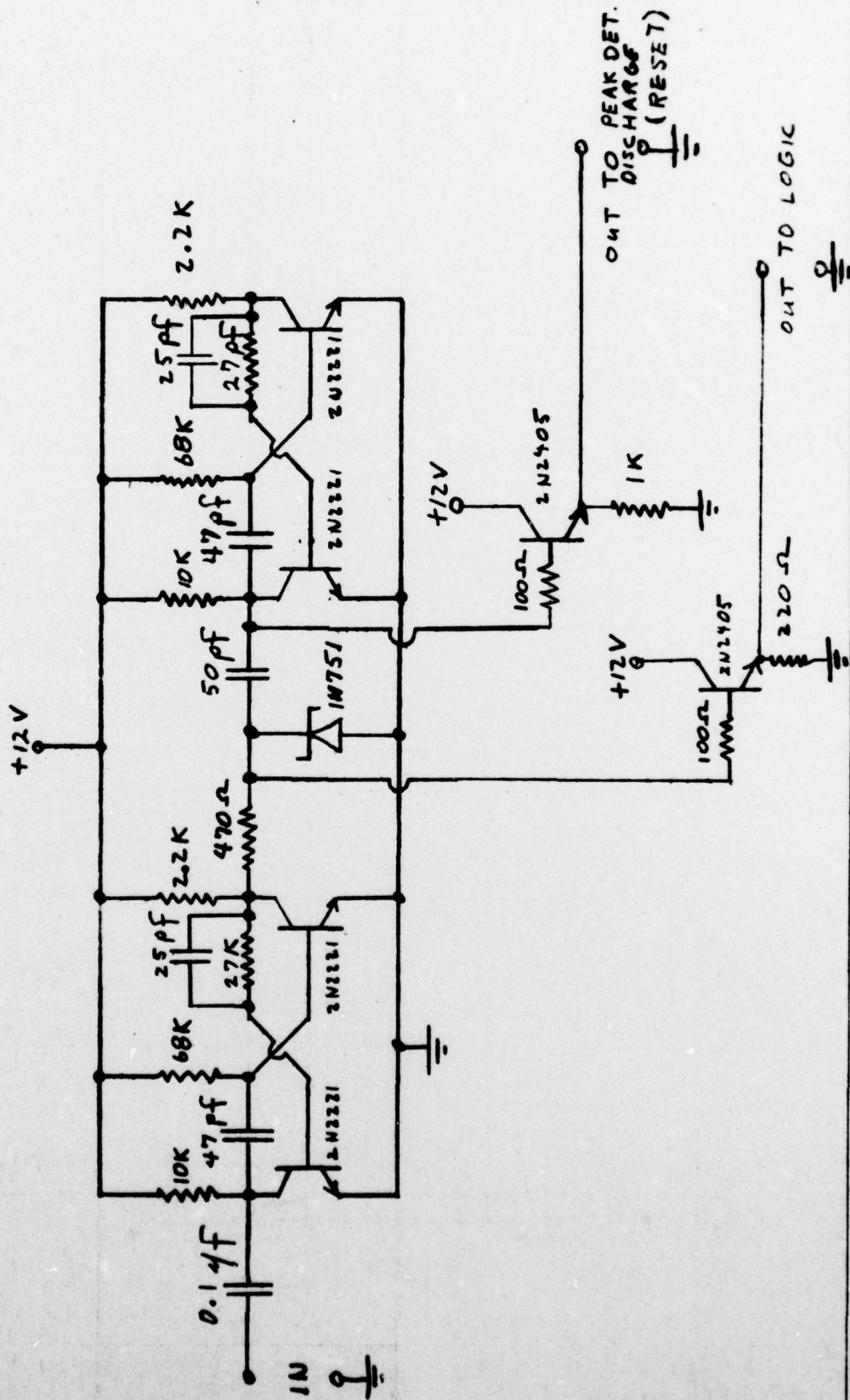

FIGURE 6

ONE-SHOT MULTI-VIBRATORS (TIMING CIRCUIT)
 OVER-THE-PEAK DETECTION SYSTEM
 J.O. Sherman 8-69

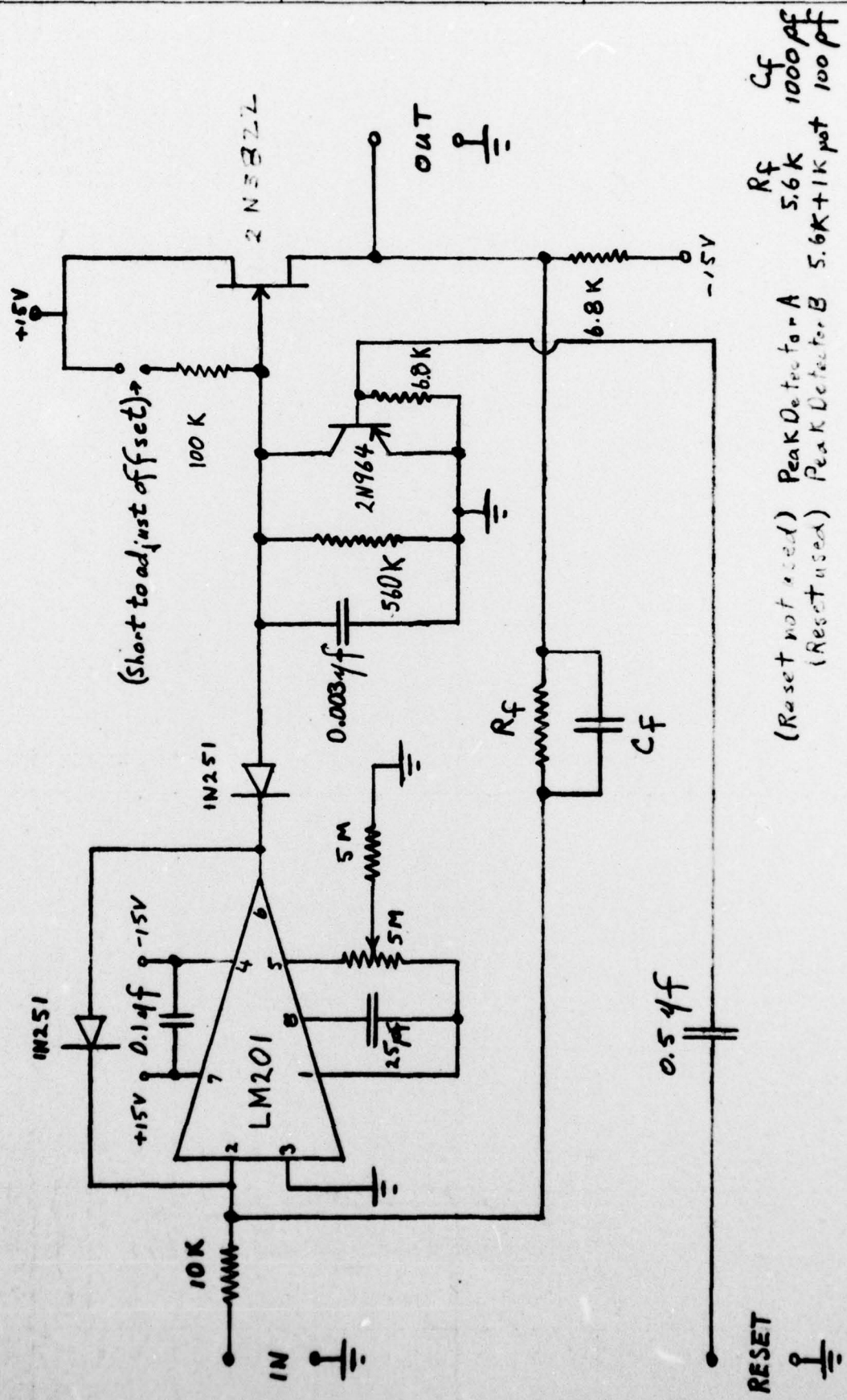
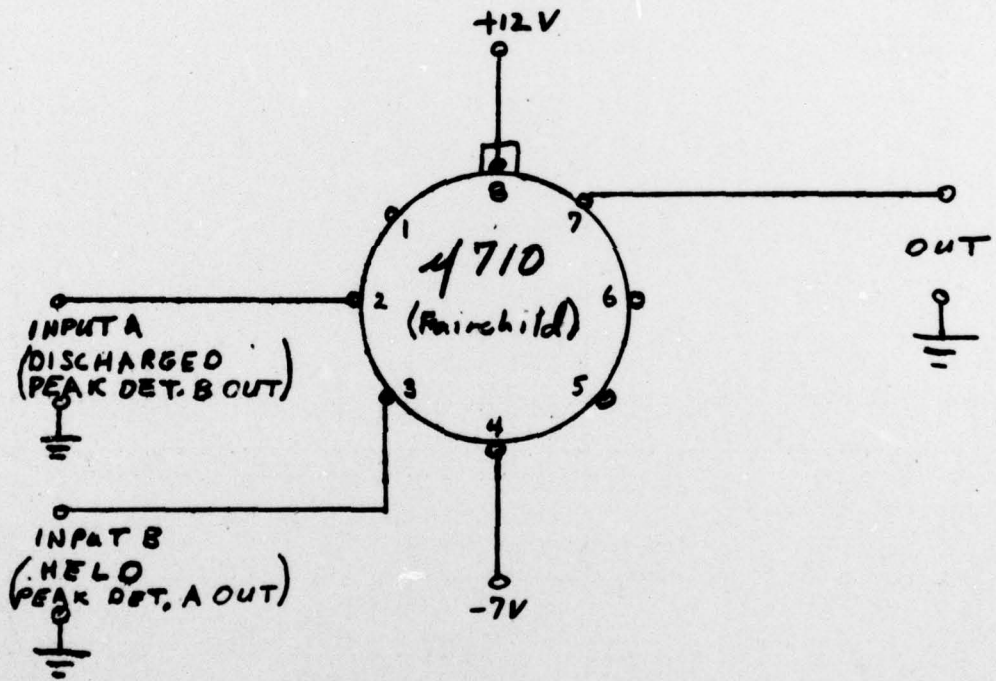

FIGURE 7

PEAK DETECTOR
OVER-THE-PEAK DETECTION SYSTEM
 J. D. Sherman 8-69



COMPARATOR
 OVER-THE-PEAK DETECTION SYSTEM
 F.D. Sherman 8-69

FIGURE 8

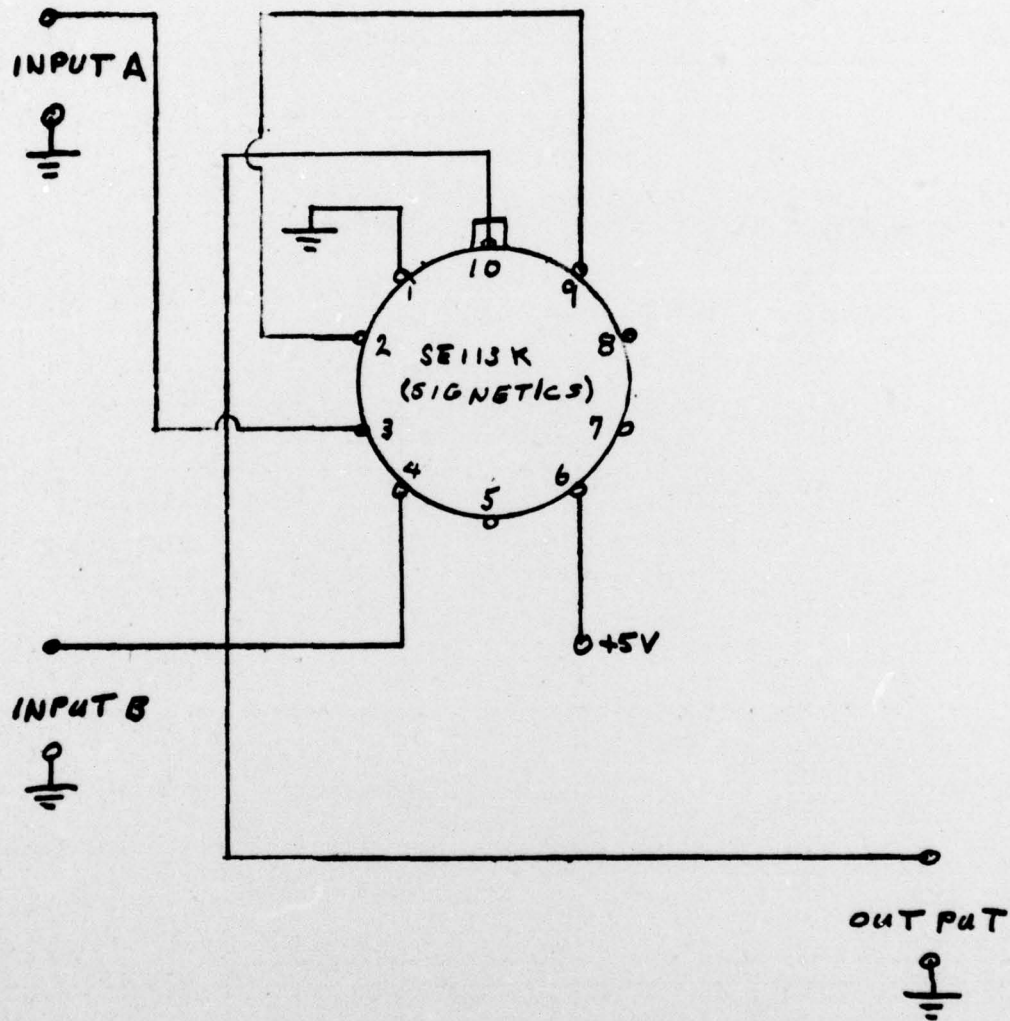

$$\text{OUTPUT} = \overline{\overline{\text{INPUT A} \cdot \text{INPUT B}}}$$

LOGIC CIRCUIT
OVER-THE-PEAK DETECTION SYSTEM
F. D. SHERMAN 8-69

FIGURE 9

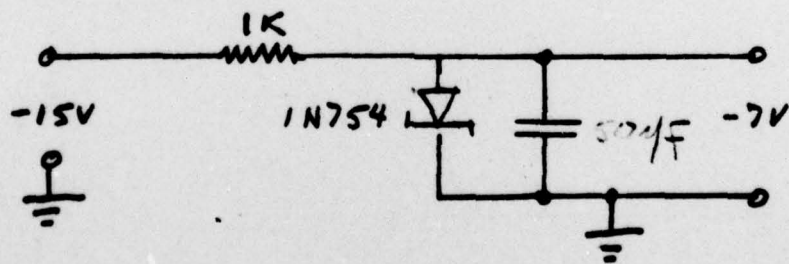
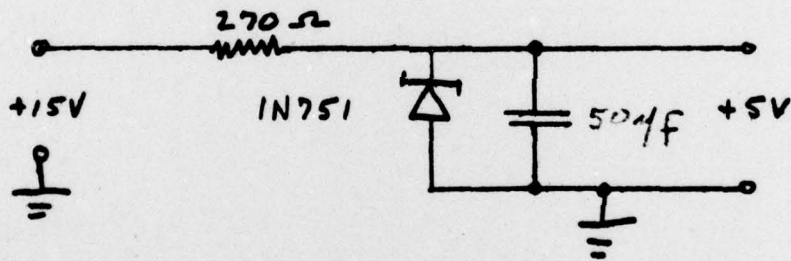
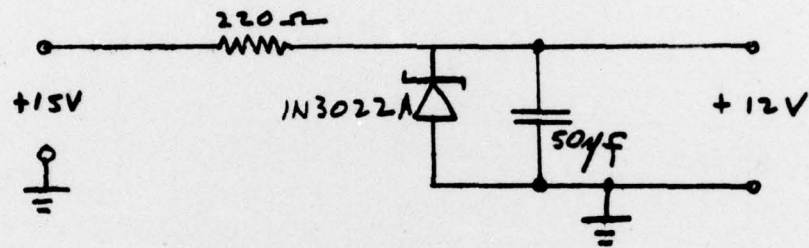

POWER CONDITIONER
 OVER-THE-PEAK DETECTION SYSTEM
 F.D. Sherman 8-69

FIGURE 10

REFERENCES

1. Andrews, F. A., "The Meaning of Error in a Short Base Underwater Navigation System", Catholic University Report of The Office of Naval Research, Code 466, Contract No. 2249(14), September 1966.
2. Magrab, E. B., "Measurement of Time Delay in a Short Base Underwater Navigation System: An Analysis of Several Methods", Catholic University Report to The Office of Naval Research, Code 466, Contract No. 2249(14), July 1968.
3. Van Ness, H. N., Mills, R. L., and Stewart, K. R., "An Acoustic Ray Ship Positioning and Tracking System", NRL Report No. 6326, October 1965.
4. Schwartz, M., "Information Transmission, Modulation and Noise", McGraw-Hill Book Company, New York 1959.
5. DiFranco, J. V., Rubin, W. L., "Radar Detection", Prentice-Hall, Inc., Englewood Cliffs, New Jersey, 1968.
6. Skolnik, M. I., "Introduction to Radar Systems", McGraw-Hill Book Co., New York, N. Y. 1962.
7. "Handbook of Operational Amplifier Active R. C. Networks", Burr-Brown Research Corporation, International Airport Industrial Park, Tucson, Arizona, 1966.
8. Vintzer, A. E., "High Accuracy Obtained from Peak Detector using Op Amp", March 17, 1969 issue of Electronics Magazine, p. 94, Mc-Graw-Hill, Inc., New York, New York.
9. Work will be conducted by Mr. C. L. Buchanan, Ocean Engineering Division of The Naval Research Laboratory.

Security Classification

DOCUMENT CONTROL DATA - R & D

(Security classification of title, body of abstract and indexing annotation must be entered when the overall report is classified)

1. ORIGINATING ACTIVITY (Corporate author) <p>The Catholic University of America</p>		2a. REPORT SECURITY CLASSIFICATION <p>Unclassified</p>	
		2b. GROUP	
3. REPORT TITLE <p>A System Design for Accurate Measurement of the Time of Arrival of an Acoustic Pulse for a Ship Positioning and Tracking System-Over-The-Peak Detection System</p>			
4. DESCRIPTIVE NOTES (Type of report and inclusive dates)			
5. AUTHOR(S) (First name, middle initial, last name) <p>John D. Sherman</p>			
6. REPORT DATE <p>October 1969</p>		7a. TOTAL NO. OF PAGES <p>18</p>	7b. NO. OF REFS <p>9</p>
8a. CONTRACT OR GRANT NO. <p>Nonr-2249(14)</p>		9a. ORIGINATOR'S REPORT NUMBER(S)	
b. PROJECT NO.		9b. OTHER REPORT NO(S) (Any other numbers that may be assigned this report)	
c.			
d.			
10. DISTRIBUTION STATEMENT <p>Distribution of this document is unlimited</p>			
11. SUPPLEMENTARY NOTES		12. SPONSORING MILITARY ACTIVITY <p>Office of Naval Research</p>	
13. ABSTRACT <p>An electronic design disclosure of a system which establishes the time of arrival of a rectangular acoustic pulse at a hydrophone is presented. The system attempts to minimize the error in the measurement of the time of arrival, as well as to provide a technique to make this measurement independent of the amplitude of the received pulse. To improve the signal-to-noise ratio, a matched filter approximation is used. To make the arrival time measurement when the signal-to-noise ratio is maximum, an over-the-peak detector is used. Since the measurement uses a characteristic of the signal equivalent to a slope change, the amplitude does not affect the measurement as it currently does on the present threshold system employed on the Mizar. A major consideration in the design was that the proposed system be compatible with the present Mizar system.</p>			

DD FORM 1473
1 NOV 65

Security Classification