

AD-A044 992

CONSTRUCTION ENGINEERING RESEARCH LAB (ARMY) CHAMPAI--ETC F/G 13/13
DOME SHELTER CONSTRUCTION WITH POLYURETHANE FOAM. (U)
AUG 77 A SMITH

UNCLASSIFIED

CERL-TR-M-225

NL

| OF |
AD
A044 992

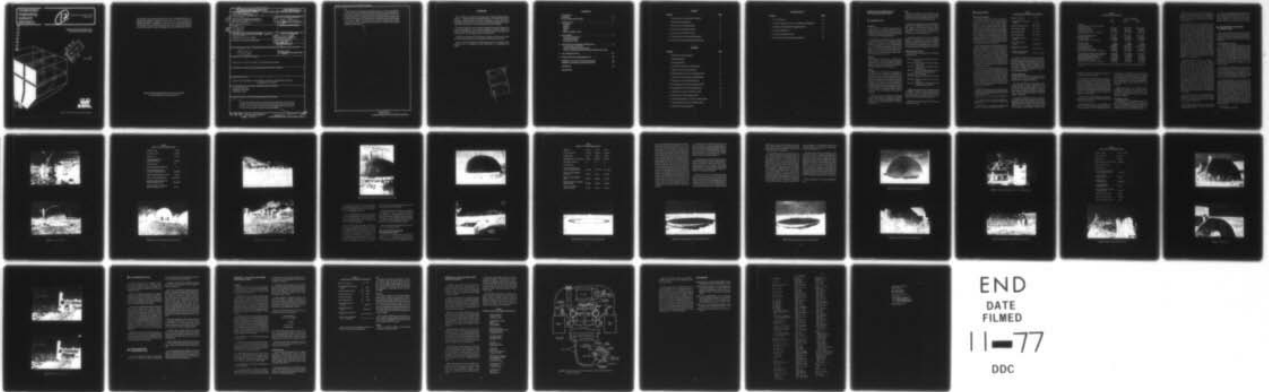

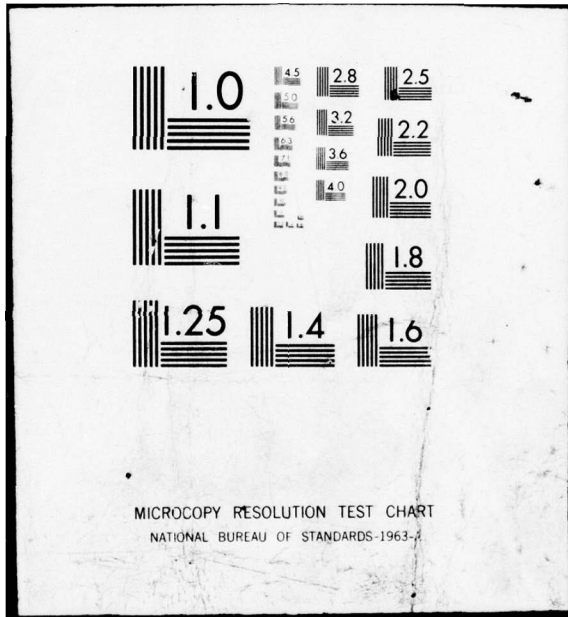

MICROCOPY RESOLUTION TEST CHART
NATIONAL BUREAU OF STANDARDS-1963-A

construction
engineering
research
laboratory

12
b.s.

TECHNICAL REPORT M-225
August 1977

ADA 044992

DOME SHELTER CONSTRUCTION
WITH POLYURETHANE FOAM

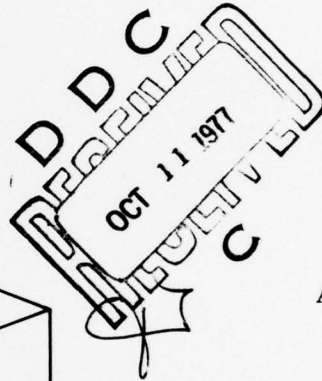
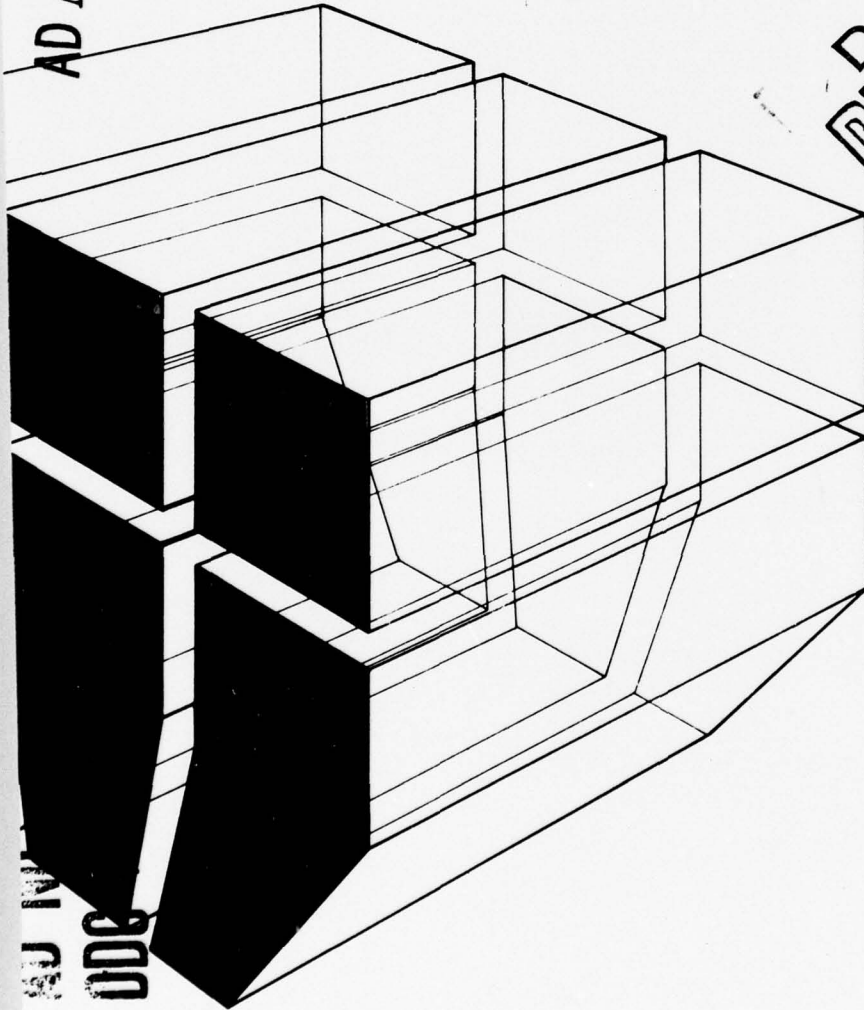

by
Alvin Smith



Approved for public release; distribution unlimited.

The contents of this report are not to be used for advertising, publication, or promotional purposes. Citation of trade names does not constitute an official indorsement or approval of the use of such commercial products. The findings of this report are not to be construed as an official Department of the Army position, unless so designated by other authorized documents.

***DESTROY THIS REPORT WHEN IT IS NO LONGER NEEDED
DO NOT RETURN IT TO THE ORIGINATOR***

REPORT DOCUMENTATION PAGE		READ INSTRUCTIONS BEFORE COMPLETING FORM	
1. REPORT NUMBER CERL-TR- TECHNICAL REPORT M-225	2. GOVT ACCESSION NO.	3. RECIPIENT'S CATALOG NUMBER	
4. TITLE (and Subtitle) DOMESHELTER CONSTRUCTION WITH POLYURETHANE FOAM	5. TYPE OF REPORT & PERIOD COVERED FINAL report	6. PERFORMING ORG. REPORT NUMBER	
7. AUTHOR(s) Alvin Smith	8. CONTRACT OR GRANT NUMBER(s)		
9. PERFORMING ORGANIZATION NAME AND ADDRESS CONSTRUCTION ENGINEERING RESEARCH LABORATORY P.O. Box 4005 Champaign, Illinois 61820	10. PROGRAM ELEMENT, PROJECT, TASK AREA & WORK UNIT NUMBERS 4A762619AT41-08-002	11. REPORT DATE August 1977	
11. CONTROLLING OFFICE NAME AND ADDRESS	12. NUMBER OF PAGES 33		
14. MONITORING AGENCY NAME & ADDRESS (if different from Controlling Office) 12/35p.	15. SECURITY CLASS. (of this report) UNCLASSIFIED		
15a. DECLASSIFICATION/DOWNGRADING SCHEDULE			
16. DISTRIBUTION STATEMENT (of this Report) Approved for public release; distribution unlimited.			
17. DISTRIBUTION STATEMENT (of the abstract entered in Block 20, if different from Report)			
18. SUPPLEMENTARY NOTES Copies are obtainable from National Technical Information Service Springfield, VA 22151			
19. KEY WORDS (Continue on reverse side if necessary and identify by block number) polyurethane foam expedient shelters inflated forms			
20. ABSTRACT (Continue on reverse side if necessary and identify by block number) This report presents the results of a study of the use of polyurethane foam in erecting expedient shelters (domes) in the Theater of Operations (TO). The evaluation indicated that these foams can effect savings in labor, time, shipping weight and volume, and material costs when compared to conventional material buildings.			

405279

Three methods of fabricating dome-shaped structures up to 28 ft (8.5 m) in diameter were evaluated. Each of the methods, which use inflated forms and spray-applied foam, can be used to advantage in TO base development. A field demonstration of one of the techniques, which uses a turntable device and an inflated balloon form, was conducted at Fort Belvoir, VA. Engineer troops participating in the field demonstration adapted quickly to the concepts, assembly, and operation of the equipment, indicating that a minimal training period would be required for personnel in units to which the foam-spraying equipment would be organic.

2

UNCLASSIFIED

FOREWORD

This investigation was conducted for the Directorate of Facilities Engineering, Office of the Chief Engineers (OCE), under RDT&E Program 6.27.02, Project 4A762619AT41, "Research for Base Development in the Theater of Operations"; Task 08, "Base Development Design and Construction"; Work Unit 002, "Foam Material Applications in Theater of Operations Construction." The OCE Technical Monitor is Mr. E. McWhite.

The work was performed by the Construction Materials Branch (MSC), Materials and Science Division (MS), U.S. Army Construction Engineering Laboratory (CERL). Laboratory and developmental work was done at CERL, and the field demonstration was conducted at the U.S. Army Engineer School at Fort Belvoir, VA.

Appreciation is expressed to Mr. Harvey Barrett, formerly of CERL, for his contribution of many innovative methods of accomplishing the tasks involved in the study.

COL J. E. Hays is Commander and Director of CERL, and Dr. L. R. Shaffer is Technical Director. Dr. G. R. Williamson is Chief of MS and Mr. P. A. Howdyshehl is Chief of MSC.

ACCESSION for	
NTIS	White Section <input checked="" type="checkbox"/>
DDC	Blue Section <input type="checkbox"/>
UNANNOUNCED	<input type="checkbox"/>
JUSTIFICATION	
BY	
DISTRIBUTION/AVAILABILITY NOTES	
SPECIAL	
D.	
[Signature]	

CONTENTS

DD FORM 1473	1
FOREWORD	3
LIST OF TABLES AND FIGURES	5
1 INTRODUCTION	7
Background	
Objective	
Approach	
Scope	
Mode of Technology Transfer	
2 DEVELOPMENT	8
Theoretical Considerations	
Practical Considerations	
Flammability of Foams	
3 EVALUATION OF FOAM DOME CONSTRUCTION.	10
Turntable/Inflated-Form Domes	
Stationary Platform/Inflated-Form Domes	
28-Ft (8.5-m) Diameter Nonstretchable Inflated-Membrane-Form Dome	
4 FIELD DEMONSTRATION	28
5 CONCLUSIONS AND RECOMMENDATIONS	28
APPENDIX A: Polyurethane Foams and Foam Systems	29
APPENDIX B: Polyurethane Foam Mixing Equipment	31
REFERENCES	33
DISTRIBUTION	

TABLES

Number	Page
1 Typical Properties of Commercial Foam Systems	8
2 Dome Design Loads and Stresses	9
3 Data on 18-ft (5.5-m) Diameter Domes	14
4 Data on 15-ft (4.6-m) Diameter Domes	18
5 Data on 28-ft (8.5-m) Diameter Dome	23
A1 Typical Properties of Commercial Foam Systems	30
B1 Partial List of Foam Spray Equipment Manufacturers	31

FIGURES

Number	Page
1 Schematic of Turntable Equipment	11
2 Turntable Membrane	11
3 Turntable Equipment	13
4 Short Distance Transport of Completed Dome	14
5 Village of 18-ft (5.5-m) Diameter Domes	15
6 Ring and Membrane for 15-ft (4.6-m) Diameter Dome	16
7 Foam on 15-ft (4.6-m) Diameter Inflated Membrane	17
8 Ring Beam for 28-ft (8.5-m) Diameter Dome	18
9 Bottom Membrane for 28-ft (8.5-m) Diameter Dome	19
10 Top Membrane for 28-ft (8.5-m) Diameter Dome	20
11 Inflated Form for 28-ft (8.5-m) Diameter Dome	21
12 Doorway for 28-ft (8.5-m) Diameter Dome	21
13 Foam Spray Equipment for 28-ft (8.5-m) Diameter Dome	22
14 Foam Application on 28-ft (8.5-m) Diameter Dome	22
15 Ladder Used in Foaming Operation	23

FIGURES (Cont'd.)

Number	Page
16 Foam Application	24
17 Operator Supported by Foam 10 to 15 Minutes After Application	25
18 Removal of Wedge-Shaped Key Ring Beam Section	25
19 Removal of Membranes	26
20 Removal of Ring Beam Sections	27
B1 Basic Component Schematic (Spray Equipment)	32

DOME SHELTER CONSTRUCTION WITH POLYURETHANE FOAM

1 INTRODUCTION

Background

The requirement for rapidly erectable shelters in building a Theater of Operations (TO) base has been recognized for many years. A fast buildup of personnel to support and conduct military activity creates a need for a rapid means of housing the personnel.

Foamed plastic materials can be used to augment the present methods of TO base development. Foam material can be shipped in a dense (approximately 70 lb/cu ft [1100 kg/m^3], sp gr 1.12) form and foamed to a very low-density (approximately 2 lb/cu ft [32 kg/m^3], sp gr 0.03) material having usable structural properties. The conversion time is short—about 2 minutes—and the time from foam formation until it can be used is only about 2 hours.

Objective

The objective of this study was to evaluate use of foamed plastic as a construction material in expedient shelters (domes) to provide improvements in logistics (weight and volume) and reductions in labor skills and man-hours required for TO base development.

Approach

Possible uses of foamed plastics were identified and investigated to verify acceptability for building structures in the TO. Use of foam as a primary structural material, a secondary structural material, and an insulating and sealing material was evaluated. The designs of structures were selected such that the best physical properties of the foams were used. Techniques for fabricating the structure were also studied. As a result of these considerations, which are discussed in Chapter 2, three methods of building dome-shaped structures up to 28 ft (8.5 m) in diameter were selected for evaluation.

Tests were conducted to demonstrate the adequacy of the design, fabrication techniques, and materials (Chapter 3). Part of the testing involved a demonstration at the U.S. Army Engineer School, Fort Belvoir, VA (Chapter 4).

Scope

This study was limited to the evaluation of polyurethane foam, which is the type of foam that provides the greatest potential (low shipping volume, easy conversion to foam, and low skill level requirements).

Foams such as polystyrene foam and polyethylene foam were not considered because they are formed under "factory" conditions and would have a significant negative effect on logistics. Because they are produced at 2 to 4 lb/cu ft (32 to 64 kg/m^3), they would occupy very large shipping volumes.

Foams which may arrive in the TO as shipping containers for munitions were initially considered. While they could be used in various ways in buildings, the special provisions which would have to be made for their use would detract significantly from their potential. They were therefore also eliminated from the study.

Mode of Technology Transfer

The results of this study will impact on the following technical manuals:

- TM 5-301—Army Facilities Component System—Planning
- TM 5-302a.—Army Facilities Component System—Designs, Vol I
- TM 5-302b.—Army Facilities Component System—Designs, Vol II
- TM 5-303—Army Facilities Component System Logistics Data and Bills of Materials
- TM 5-349—Arctic Construction
- TM 5-808-9—Structure Design: Thin Shell Construction
- TM 5-852-9—Arctic and Sub-Arctic Construction—Building
- TM 5-882-2—Engineering and Design-Structure Design—Emergency Construction

Training may be implemented by appropriate entries in ARTEP 115 Engineer Combat Battalion (Heavy). Construction method and materials described herein offer an alternative to temporary shelters described in FM 20-15, "Tents, Pole and Frame Supported."

Procedures for various methods of construction are described in this report.

2 DEVELOPMENT

Theoretical Considerations

If low-density polyurethane foam is to be useful in a structural role, the design of the structure must reflect proper use of the foam. Its low strength (Table 1) prohibits its use in a conventional structural application, but its high strength-to-weight ratio (approximately equal to concrete) does allow it to be used in certain structural applications where externally applied forces are low and well distributed. For example, structural shapes such as domes and arches are better than conventional box building shapes, because they reduce bending movements to axial in-plane stresses. Bending movements in a curved plate tend to distribute stresses over a wider area, while junctions between vertical walls and roofs concentrate them.

Several building shapes and configurations have been studied previously. Domes, arches, folded plates, and others were designed and tested at the University of Michigan in their research on housing for underdeveloped countries.¹ The Dow Chemical Company has developed a "spiral generation" technique for forming a dome by bending their Styrofoam sheets and bonding them together.² Palfey's study of size limitations of foam dome structures has shown that design loads and stresses on foam domes up to 100 ft (30.5m) in diameter (Table 2) are well within the strength limits for low-density plastic foams.³

Curved plates, while offering advantages, are not the only use for foams. Vertical wall/pitched-roof structures can make substantial use of foams between high-strength skins in composite panels. The skins resist the large extreme fiber tension and compressive stresses, and the foam cores resist the smaller tensile, compressive, and mid-depth shear forces. The stresses in the skin can be altered easily by varying the thickness of the foam core. Becker⁴ provides details of panel design and expected resulting strengths.

¹Stephen C. A. Paraskevopoulos, *Architectural Research on Structural Potential of Foamed Plastics for Housing in Underdeveloped Areas* (Architectural Research Laboratory, The University of Michigan, 1965).

²*Spiral Generation of Domes* (The Dow Chemical Co., 1959).

³A. J. Palfey, *Research on Foam-in-Place Equipment to Produce Shell Structures*, Dow Report No. FPS-435-14 (January 1973), p 6.

⁴Walter E. Becker, *U. S. Sandwich Panel Manufacturing/Marketing Guide* (Technomic Publishing Co., 1968).

Table 1
Typical Properties of Commercial Foam Systems

Density, lb/cu ft (kg/m ³)	2.0 (32)
Compressive Strength (10% strain), psi (kPa)	35 (241)
Compressive Modules, psi (kPa)	1000 (6895)
Tensile Strength, psi (kPa)	38 (262)
Shear Strength, psi (kPa)	25 (172)
Shear Modulus, psi (kPa)	400 (2758)
K Factor, Btu/hr/sq ft/F/in. (W/m K)	0.12 (0.02)
Water Absorption, lb/sq ft (kg/m ²)	0.033 (0.161)
Maximum Service Temperature, °F (°C)	200 - 250 (93 - 121)
Coefficient of Linear Expansion, in./in./°F (mm/mm/°C)	6 × 10 ⁻⁵ (1.1 × 10 ⁻⁴)

In addition to the structural roles of foamed polyurethane in construction, it has two other important functional capabilities. Properly applied, it can provide outstanding thermal and acoustical insulation. It provides sound insulation mainly by rigidizing panel components in buildings, thus decreasing their ability to retransmit vibrations. Appendix A describes its thermal insulation properties.

Practical Considerations

Simple, quickly made shelters are needed in TO base development. The use of spray-applied foam polyurethane offers both simplicity and speed.

The foam components are commercially available in large quantities, are stable, and are dense in the shipping and storage condition (liquids). Upon arrival at a TO site, the liquid components are easily and rapidly expanded using simple equipment. Appendices A and B discuss the foam materials and the spray equipment, respectively.

Formwork for erecting the foam can be as simple as an air-inflated form which occupies little volume in shipping and storage. The reusable form can be of lightweight film which can be placed at the desired site with minimum effort. A low-volume, low-pressure blower unit is sufficient to provide inflation air. More elaborate

Table 2*
Dome Design Loads and Stresses

	Dome Ground Diameter		
	30 Ft (9.1 m)	50 Ft (15.2 m)	100 Ft (30.5 m)
Wind Loads:			
100 mph wind velocity = 25.88 psf (129313 kPa)			
Total uplift load, lb (kg)	9317 (4235)	25,880 (11764)	103,500 (47045)
Base uplift load, lb/lin ft (Pa)	98.9 (1443)	165 (2408)	330 (4816)
Base wall tension, psi (kPa)	1.37 (9445)	2.29 (15789)	4.58 (31578)
Base wall tension, psi, (kPa) @ 1.33 Safety factor	1.82 (12548)	1.79 (12341)	2.99 (20615)
Total horizontal wind load, lb (kg)	9147 (4158)	25,443 (11565)	103,500 (47045)
Base shear, lb/linear ft (Pa)	97 (1416)	162 (2364)	324 (4728)
Base shear, psi (kPa)	1.35 (9308)	2.25 (15513)	4.49 (30957)
Base shear, psi (kPa) @ 1.33 Safety factor	1.79 (12341)	3.04 (20960)	5.96 (41093)
Dead Load, psf (kPa)	1 (4788)	1 (4788)	1 (4788)
Live Load, psf (kPa)	30 (143640)	30 (143640)	30 (143640)
Total load on dome, lb (kg)	21,913 (9960)	60,868 (27667)	243,474 (110670)
Base load, lb/lin ft (Pa)	232 (3386)	387 (5648)	775 (11310)
Base compressive stress, psi (kPa)	3.22 (22201)	5.37 (37025)	10.76 (74188)
Base compressive stress, psi (kPa) @ 2 Safety factor	6.44 (44402)	10.74 (74050)	21.52 (148375)
Critical buckling load, psf (kPa) (without reinforcing)	188 (900144)	66.6 (318881)	16.6 (79481)
Critical buckling load, psf (kPa) @ 2 Safety factor	94 (450072)	33.3 (159440)	8.3 (39740)
Maximum meridional stress, psi (kPa)	3.24 (22339)	5.4 (37232)	10.8 (74463)
Meridional stress, psi (kPa) @ 2 Safety factor	6.48 (44678)	10.8 (74463)	21.6 (148927)
Maximum hoop stress, psi (kPa)	3.24 (22339)	5.4 (37232)	10.8 (74463)
Maximum hoop stress, psi (kPa) @ 2 Safety factor	6.48 (44678)	10.8 (74463)	21.6 (148927)

*From A. J. Palfey, *Research on Foam-in-Place Equipment to Produce Shell Structures*, Dow Report No. FPS-435-14 (January 1973), p 6.

air-inflated formwork can be used if many shelters of the same size and type are required.

Site preparation is minimal for foam construction. Since the building is lightweight, extensive foundation work can be eliminated. A concrete floor slab can be installed and the building erected over it, or the building can be built first and then the slab poured. Since the building is lightweight, anchoring must be provided to prevent it from being lifted by wind. Ground anchors and ropes or earth backfill around the structure are sufficient to assure stability.

Labor intensity for foam building erection is low. A four-man team is required to operate the equipment and coordinate construction.

Labor skill levels can also be low. The skills associated with paint spraying are easily augmented to allow foam spraying. A brief training period of about

40 man-hours can provide the necessary knowledge and skills for an average individual to be reasonably proficient. Maintenance of the spray foam equipment is very important, as are trouble-shooting techniques. The noncommissioned officer in charge (NCOIC) or team leader could be easily trained to direct these functions.

Finishing the foam work to provide durability, fire/flame spread resistance, and camouflage can be accomplished by painting for durability and camouflage, and by applying a cementitious coating for fire/flame spread resistance.

Flammability of Foams

The flammability of foamed plastics has been the object of much discussion and research in the past few years. The extremely rapid burning and highly toxic combustion products have caused a great deal of concern about the use of foams in habitable structures.

Organic foams will burn. The rates of burning and the flame spread depend on many factors, whose interdependency makes it impossible to cite examples and results of foams in fires, or to predict exact performance of any particular foam.

Generally, foams burn more easily than their solid polymer counterparts because of the greatly increased surface area presented for thermal decomposition of the material. A coating which impedes the thermal attack on the foam will usually greatly reduce flame spread. Cementitious materials (cement, lime, sand, and water) brushed or troweled directly on the surface of the foam have been found effective in limiting the foam's fire involvement.⁵ Recent tests have indicated that 1 in. hexagonal wire mesh stapled to the foam surface should be applied prior to trowling the cementitious materials. The wire mesh assists in bonding the cementitious material to the foam, and is particularly important when significant temperature cycling is anticipated. Since the foam will burn in an established fire, it is extremely important that protective coatings be applied to exposed foam very soon after the foam application is completed, preferably before other finishing operations commence.

Combustion products, whether from complete or incomplete oxidation or the molecular fragments pyrolyzed from the polymer, may be toxic. As in any fire, the most serious component is usually carbon monoxide. Other toxic species such as hydrogen cyanide may be present, but the amount is typically about the same or less than would be formed from wood, nylon, or wool burning under the same conditions. Compounding the possible toxic products problem is the smoke generated by burning or partially burning foams. Dense, black, sooty smoke capable of obscuring light and visibility can be reduced by limiting the foam's involvement in a fire; this can be done by applying an effective flame-resistive coating such as the previously described cementitious coating, by using plaster or by using some other refractory coating. Steel mesh and glass or steel fibers improve coating adherence and durability.

The relatively small sizes of TO housing structures facilitate quick exit in the event of a fire. Personnel would thus be afforded additional protection because of short potential exposure time.

⁵Alvin Smith, *Fire/Flammability Test of Polyurethane Foams and Protective Coatings*, Technical Report M-129/ADA028386 (CERL, 1976).

In summary, although foamed plastics generally will burn, effective fire/flame-resistant coatings can be made and applied in the TO from materials that are normally available there. These coatings will afford adequate protection to personnel in the event of a fire.

3 EVALUATION OF FOAM DOME CONSTRUCTION

Three sizes of foam domes were made using three different techniques. All the techniques involved spraying foam material onto an air-inflated membrane. Each technique was evaluated relative to field use in TO base development.

Turntable/Inflated-Form Domes

A turntable device and related equipment for making 18-ft (5.5-m) diameter domes were leased from the West German company Fabenfabriken Bayer through a subsidiary, the Mobay Chemical Company. The equipment, which was developed for spray-in-place foam shelters, has been successfully used in erecting shelters as disaster relief housing following major earthquakes in Turkey, Peru, and Nicaragua. The several hundred igloo-shaped structures built in those three areas afforded strong, weatherproof housing on a mass-production basis.

The technique involved assembling a ring (aluminum) by bolting together sectors. The ring, which was supported by and traveled on rubber pneumatic tires mounted on platforms beneath it, was aligned by spokes to a center hub through which an air inlet port passed. Figure 1 is a schematic drawing of the equipment.

A balloon form made of 1/8-in. (3.2-mm) thick polyvinyl chloride sheet (Figure 2) was attached to the ring and spokes and sealed around the air inlet port. When inflated, the balloon was essentially hemispherical. An air compressor some distance from the turntable supplied air through a 4-in. (102-mm) diameter hose connected to the inlet port in the hub. Air pressure was regulated by a sliding plate valve located in the delivery hose. Excess air was diverted out of the system. Since the balloon was made of a stretchable material, maintaining internal pressures of about 1 psi (6.9 kPa*) maximum was important. Variation in air pressure could have resulted in a corresponding variation in form size.

*kPa = kilopascals = 1000 pascals.

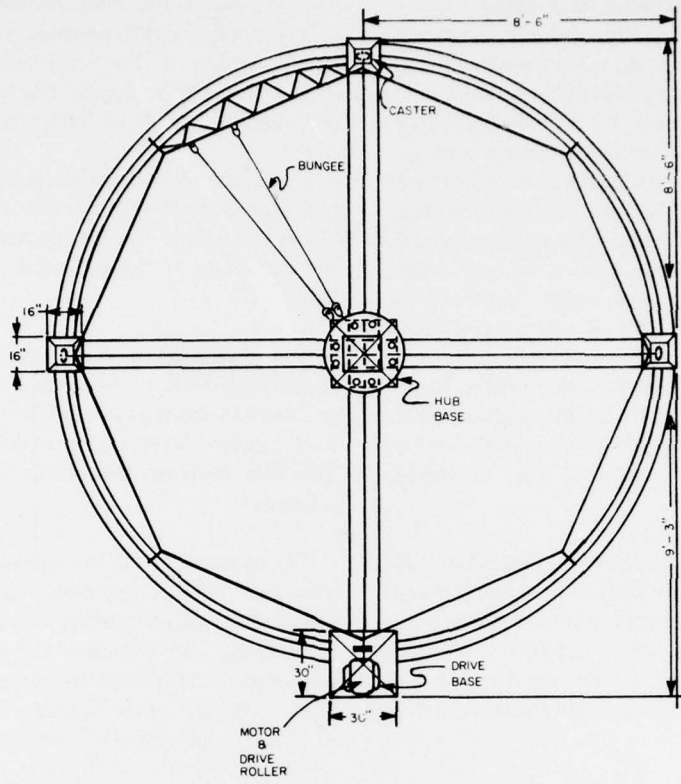

Figure 1. Schematic of turntable equipment.

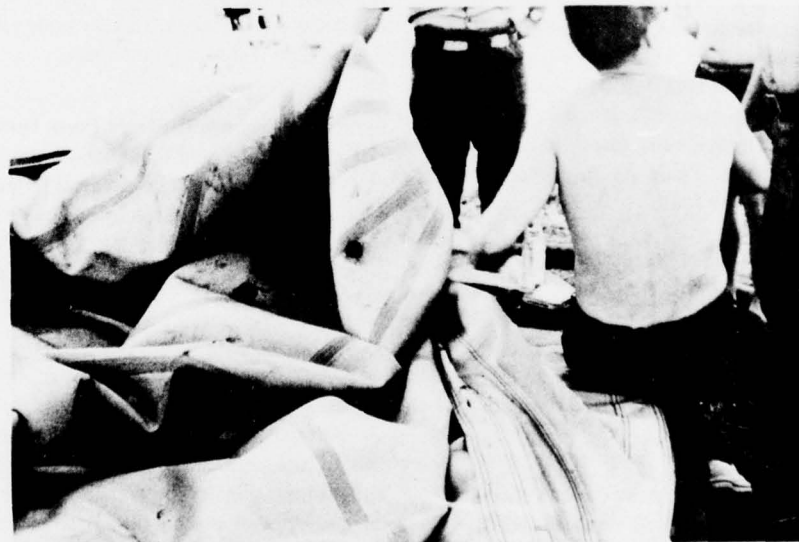

Figure 2. Turntable membrane.

The form work was completed by installing a three-legged tubular aluminum gantry over the turntable. This gantry was designed so that when the balloon was inflated, the distance from the legs of the gantry to the balloon surface was a constant 3 ft (0.9 m). One leg of the gantry supported a sprocket chain and gear arrangement to which the spray gun could be attached and held in a stable position. The sprocket chain and gear were controlled by a hand wheel. The spray gun could thus be kept a constant distance from the form while being moved from bottom to top. Figure 1 shows a plan view of the ring and hub portions of the equipment.

Before the foam was sprayed on the inflated form, the membrane was coated with a light, uniform layer of oil to prevent adhesion of the foam material to the form and to allow easy removal of the foam shape from the form.

In addition, a wind-driven vane ventilator was attached to the top of the inflated balloon and covered with plastic film. Bubble-shaped windows of thermoformed acrylic sheet were also attached at desired locations and covered with film. The foam locked the ventilator and windows securely within the structure of the dome.

The spray equipment used with the turntable was part of the package leased. It sprayed about 12 lb/minute (54.4 kg/minute) of liquid foam mixture onto the balloon form. Figure 3 shows the complete equipment in operation.

A typical commercial low-density (2 lb/cu ft [32 kg/m³]) foam system was used. It foamed within about 5 seconds after mixing and spraying. Mixing occurred immediately prior to the material's leaving the spray gun, and foaming occurred almost instantly after the mixture reached the form. Table A1 in Appendix A lists typical properties of the foam.

The foam spray was applied to the balloon form in uniform layers by moving the spray gun along the gantry leg so that the spray pattern overlapped the previous area covered. The turntable speed (about 20 rpm) was held constant and was powered by an electric motor which drove one of the tires upon which the turntable was supported (Figure 1).

Material was applied in successive layers until the desired thickness of about 4 in. (102 mm) was reached. The rotation of the form caused the annular appearance of the finished dome. An extra ring of foam was built

up at the base of the dome to strengthen it and to serve as a key to hold the dome in place when earth was banked against it. For long-term location, the dome should be set in a circular trench about 1 ft (0.3 m) deep, and dirt should be filled in around the dome.

Upon completion of the foam spraying, the turntable was stopped and the inflation compressor turned off. A small hole was cut through the foam to allow the membrane to be collapsed by pushing against it with a stick.

Ten people lifted the completed dome (Figure 4) and transferred it to the desired location, where it was anchored by passing two ropes over the apex. The ropes were attached to metal stakes driven into the ground. The film covering the ventilator and windows was removed.

Doorways were cut in some of the domes to allow personnel entry. Long radius curves should be used rather than square corners to reduce the stress concentrations. The minimum radius of curvature of an unframed corner should not be less than one-eighth the least dimension of the opening. The height and width of framed and unframed openings should not exceed one-sixth and one-twelfth the circumference of the dome, respectively. Doors can be seen in Figure 5, which shows part of a village of foam domes made by the turntable method.

The tests indicated that the turntable-formed domes represent a mass-producible type of shelter which can be transported short distances after fabrication. Table 3 gives data regarding the domes.

Stationary Platform/Inflated-Form Domes

Fifteen-ft (4.6-m) diameter domes were formed by spraying foam material onto air-inflated film affixed to a ring form which was solidly constructed of poured concrete and had a wooden floor (Figure 6). An air duct led from the side of the base to about the center of the floor.

A 40-mil-thick polyurethane rubber film was used as the inflatable form. Maintaining a nearly constant air pressure within the film was necessary, since the size of the form was subject to considerable variation with fluctuations of air pressure. A mold release material was applied to the film first to prevent the foam from adhering to the form. Figure 6 also shows the inflated form.

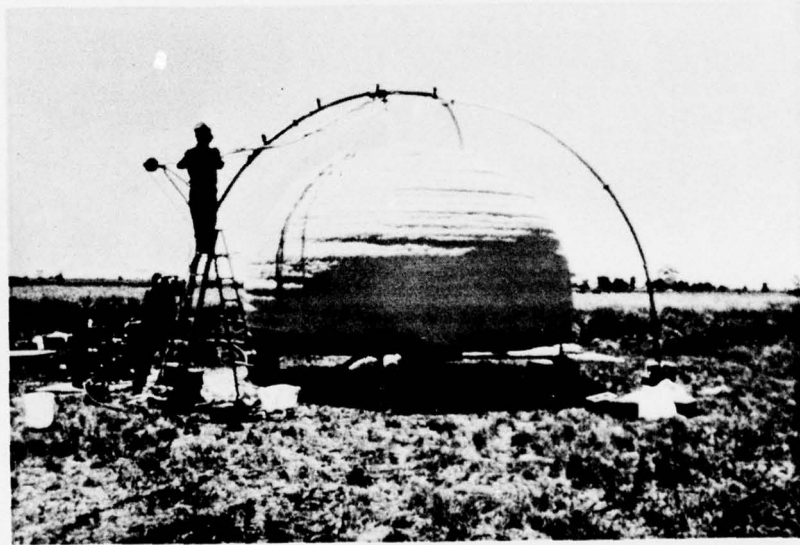
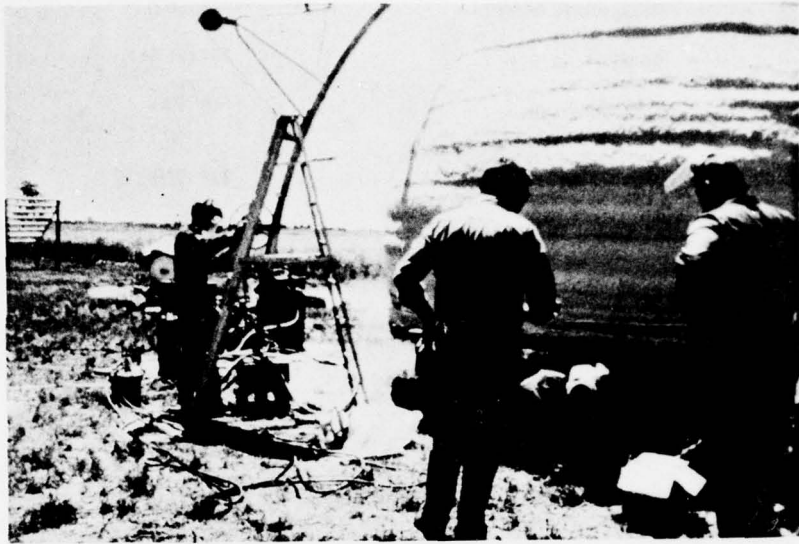

Figure 3. Turntable equipment.

Table 3
Data on 18-ft (5.5-m) Diameter Domes

Thickness, in. (mm)	4 (102)
Floor area, sq ft (m ²)	254 (23.6)
Diameter, ft (m)	18 (5.5)
Approximate weight @ 4 in. (102 mm) thick, lb (kg)	750 (340)
Time to form, hours	1.5
Personnel required (excluding moving)	3
Cost of foam material per sq ft of floor space (1976 prices), \$ (\$/m ²)	1.90 (20.45)
Volume of materials (shipping), cu ft (m ³)	20 (0.6)
Weight of materials (shipping), lb (kg)	<1000 (450)
Approximate weight of equipment for fabrication (shipping), lb (kg)	4500 (2040)
Approximate volume of equipment for fabrication (shipping), cu ft (m ³)	500 (14)



Figure 4. Short distance transport of completed dome.



Figure 5. Village of 18-ft (5.5-m) diameter domes.



Figure 6. Ring and membrane for 15-ft (4.6-m) diameter dome.

A commercial 2 lb/cu ft (32 kg/m^3) polyurethane foam formulation essentially the same as that used in making turntable-inflated domes was used. Figures 7 and 8 show foam applied to the form.

A foam spray machine like the one depicted in Figure B1 in Appendix B was used. The operator walked around the form and used a hoisted platform for spraying the top. The output of the foam machine was about 8 lb/minute (3.6 kg/minute).

Domes of three foam thicknesses were made to determine the minimum practical thickness that would allow handling associated with relocating the dome. One dome was about 1.5 in. (38 mm) thick over the top and about 2.5 in. (64 mm) thick around the bottom 2 ft (0.6 m). A second dome was uniformly 3.5 in. (89 mm) thick, and a third dome was about 5 in. (127 mm) thick. Thickness was determined by inserting a thin, stiff wire through the foam until it touched the

form membrane, and then measuring the length of wire required to penetrate the foam layer.

During transportation, the domes were supported on a triangle of 2×12 in. (51×305 mm) boards which were supported by a cable sling above the dome. All three domes survived transportation without incident. The thinnest was quite flexible and deformed readily, but resumed its shape when placed on level ground. All three domes were easy to handle and transport.

Table 4 gives pertinent information about each of the 15-ft (4.6-m) diameter domes.

28-Ft (8.5-m) Diameter Nonstretchable Inflated-Membrane-Form Dome

A 28-ft (8.5-m) diameter dome was formed by spraying 2 lb/cu ft (32 kg/m^3) foam material on an inflated form of a nonstretchable membrane attached to a portable ring beam form. The ring beam was made

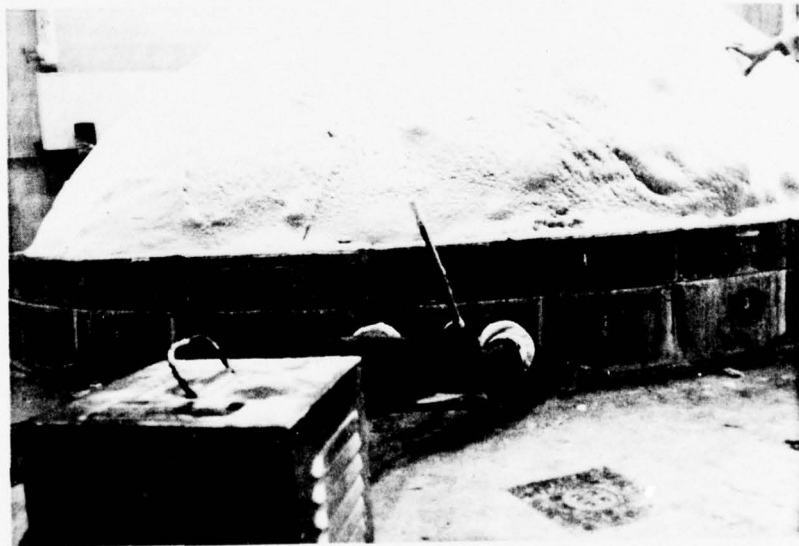
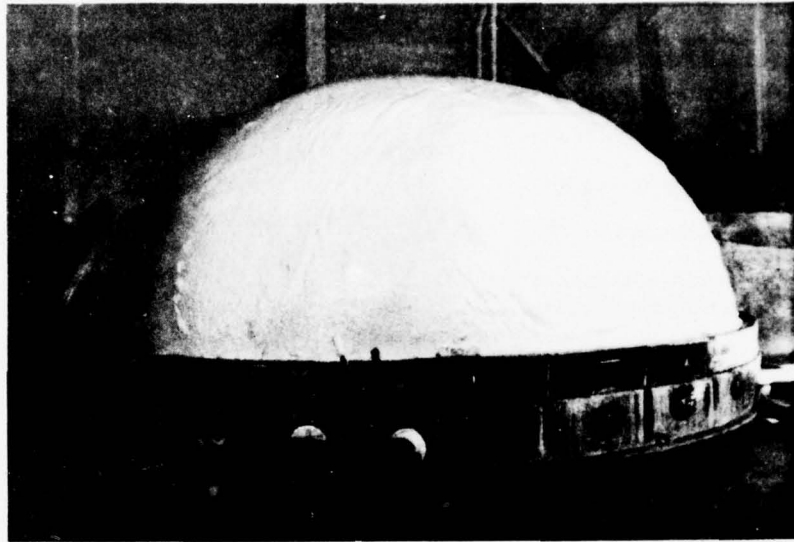

Figure 7. Foam on 15-ft (4.6-m) diameter inflated membrane.

Table 4
Data on 15-Ft (4.6-m) Diameter Domes

Thickness, in.	1.5 (38)	3.5 (89)	5 (127)
Floor Area, sq ft (m ²)	176 (16.2)	176 (16.2)	176 (16.2)
Diameter, ft (m)	15 (4.6)	15 (4.6)	15 (4.6)
Approximate weight of dome, lb (kg)	130 (60)	260 (120)	370 (170)
Time required to foam, hrs	0.6	0.9	1.3
Personnel required	2	2	2
Cost of foam material per sq ft of floor (1976 prices), \$ (\$/m ²)	.52 (5.60)	1.04 (11.19)	1.47 (15.82)
Volume of materials (shipping), cu ft (m ³)	2 (0.06)	4 (0.11)	5.5 (0.16)
Weight of materials (shipping), lb (kg)	130 (60)	260 (120)	370 (170)
Weight of equipment for fabrication (shipping), lb (kg)	300 (140)	300 (140)	300 (140)
Volume of equipment for fabrication, cu ft (m ³)	10 (0.28)	10 (0.28)	10 (0.28)



Figure 8. Ring beam for 28-ft (8.5-m) diameter dome.

by arranging fiberglass-reinforced polyester (FRP) arc sections in a circle. Each section had a 12 by 12 in. (305 by 305 mm) cross section and was one-tenth of the circumference of the 28-ft (8.5-m) diameter circle, or about 9 ft (2.7 m) long. Each section weighed about 75 lb (34 kg) and could thus be carried by one person. The two sides and top of each section were made of 1/8-in. (3.2-mm) thick FRP, and the interior of each section was filled with 2 lb/cu ft (32 kg/m³) foam to provide rigidity. One section was divided into thirds so that the center third could act as a key that could be removed toward the outward side of the ring. Each section was provided with a 3/4-in. (19-mm) thick by 2-in. (51-mm) wide lip along the top edge of the outward side to allow fastening the sections of the beam together; steel banding was passed around the ring beam and tensioned at the bottom edge of the lip. In addition, a semicylindrical slot was molded in the end of each section to act as a key-way for a 2-in. (51-mm) diameter pipe. The purpose of the pipe key was to prevent the sections from shifting with respect to one another. Figure 8 shows the assembled ring beam. As the figure shows, a minimum amount of site work was required.

The membrane form consisted of two parts. A flat sheet was stretched over the ring beam and held in place by a steel band tensioned immediately below the lip of the beam—like a drum head (Figure 9). The top (crown) membrane was prefabricated to the necessary shape and attached to the ring beam in a manner similar to the bottom membrane (Figure 10).

A low-pressure blower unit was used to blow air between the membranes to inflate the form (Figure 11). The blower, which had a capacity of 40 cfm (1.1 m³/minute), operated on 110 V power. Low pressure (approximately 0.5 psi [3.4 kPa]) was used, and an exhaust tube with a gate valve was used to regulate the pressure to a relatively constant value.

A preformed 3 ft 0 in. by 6 ft 8 in. (0.9 m by 2.0 m) doorway unit was erected so that the bottom of the door was even with the bottom of the form and the opening coincided with the wedge-shaped key in the ring beam. The door was braced in a plumb position. A corrugated paper form was used to connect the doorway unit and the inflated form. This paper form was



Figure 9. Bottom membrane for 28-ft (8.5-m) diameter dome.

stapled to the doorway unit and stapled to the membrane. Figure 12 shows the doorway after part of the foaming operation was completed. The arched top was used to reduce stress concentrations.

Foam material was sprayed on the inflated form at a rate of about 8 lb/minute (3.6 kg/minute). Figure 13 shows the equipment used for spraying the foam. The first course was about 6 in. (152 mm) thick and reached about 7 ft (2.1 m) up the form (Figure 14). The spray gun operator walked along the ground to apply the first course. The second course was applied from a stepladder leaned against the foamed first course (Figure 15). Additional courses were applied around the form from ladders until the top of the form was completed (Figure 16). As the angle of spray application decreased from perpendicular, the texture of the foam surface became rougher and there was a tendency to apply a greater thickness of foam than was actually needed. A 20 to 25 mph (32 to 40 km/hr) wind somewhat hampered spraying operations. The

foam was capable of supporting the weight of the operator within 10 to 15 minutes after foam application was completed (Figure 17).

Less than an hour after foam spraying was completed, the membrane was deflated and pushed down to the floor of the foam dome. Ring sections were loosened by cutting the steel strapping that secured them to the bottom and crown membranes. The wedge-shaped key section was removed (Figure 18), and the remainder of the beam sections moved toward the center of the dome to release the membranes. The crown membrane was folded and stowed, followed by the bottom membrane (Figure 19). The ring sections were then removed for storage (Figure 20). The ease of handling indicated that the membranes and ring sections can be easily transferred to other erection sites.

Table 5 presents data on the 28-ft (8.5-m) diameter dome.



Figure 10. Top membrane for 28-ft (8.5-m) diameter dome.

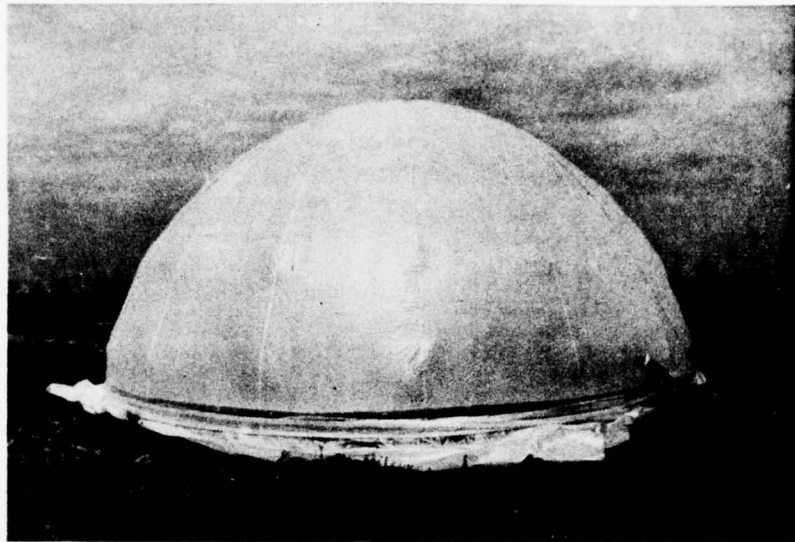

Figure 11. Inflated form for 28-ft (8.5-m) diameter dome.

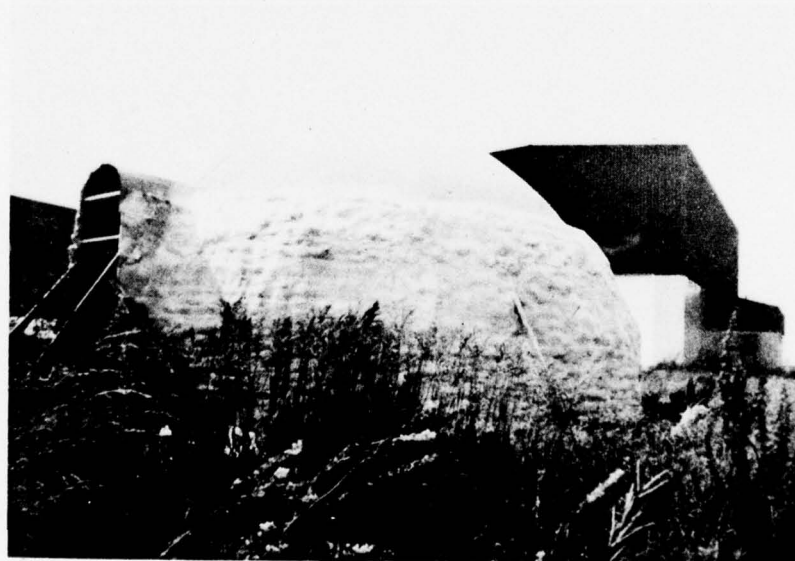

Figure 12. Doorway for 28-ft (8.5-m) diameter dome.

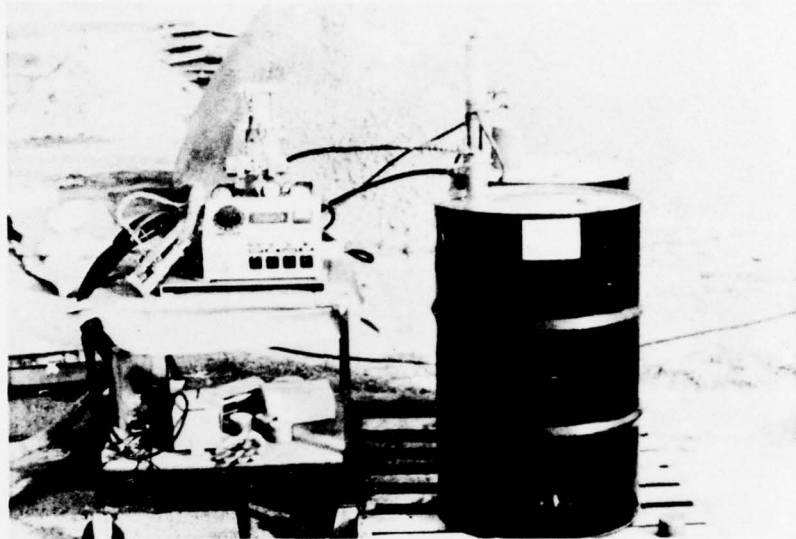

Figure 13. Foam spray equipment for 28-ft (8.5-m) diameter dome.



Figure 14. Foam application on 28-ft (8.5-m) diameter dome.

Table 5
Data on 28-Ft (8.5-m) Diameter Dome

Thickness, in. (mm)	6 to 8 (152 to 203)
Floor area, sq ft (m ²)	615 (57.1)
Diameter, ft (m)	28 (8.5)
Approximate weight of dome, lb (kg)	1500 (680)
Time required to foam, hrs	10
Personnel required	3
Cost of foam materials per sq ft of floor (1976 prices), \$ (\$/m ²)	1.54 (16.58)
Volume of materials (shipping), cu ft (m ³)	30 (0.8)
Weight of materials (shipping), lb (kg)	1500 (680)
Volume of equipment (shipping), cu ft (m ³)	10 (0.3)
Weight of equipment for fabrication (shipping), lb (kg)	300 (140)
Weight of membranes, lb (kg)	60 (30)
Weight of ring sections, lb (kg)	750 (340)
Volume of ring sections, cu ft (m ³)	90 (2.5)



Figure 15. Ladder used in foaming operation.



Figure 16. Foam application.



Figure 17. Operator supported by foam 10 to 15 minutes after application.



Figure 18. Removal of wedge-shaped key ring beam section.



Figure 19. Removal of membranes.



Figure 20. Removal of ring beam sections.

4 FIELD DEMONSTRATION

A field demonstration was conducted at Fort Belvoir, VA to demonstrate the techniques involved in using the turntable equipment for making 18-ft (5.5-m) diameter domes to personnel of the U.S. Army Engineering School.

Officers and enlisted personnel from an engineer company at Fort Belvoir participated in the exercise. All adapted quickly to the concepts, assembly, and operation of the equipment required for dome generation. Technical assistance was provided by CERL personnel and Mobay Chemical Company.

Three domes were fabricated during the demonstration. Two were formed from 2 lb/cu ft (32 kg/m^3) foam. When the domes were completed, a lowboy transport moved them along a short section of roadway to prepared sites, where they were anchored to the ground. A coat of oil-based paint was applied to increase the foam's weatherability. Fabrication of a third dome using a much higher density (approximately 15 lb/cu ft [240 kg/m^3]) polyisocyanurate foam was attempted. Forming of the dome progressed without incident, but removal of the dome from the form proved difficult. It was damaged and subsequently destroyed.

Participants in the field demonstration reacted very favorably to the dome work. Their quick adaptation to the work indicated that a minimal training period would be required for personnel in units to which the foam-spraying equipment would be organic.

5 CONCLUSIONS AND RECOMMENDATIONS

This study indicated that foamed polyurethane materials can be used to erect shelters in a TO environ-

ment. A limited number of low-skill-level personnel can erect such shelters quickly and efficiently.

Training for units which are equipped with foam spray shelter erection capabilities can be accomplished in about 40 man-hours.

Each of the three fabrication techniques evaluated appears to be suitable for use in base development in theaters of operation, if Army doctrine and TOEs/TDAs are modified to provide the necessary equipment, skills, and material for operation and maintenance of required material. The turntable-supported inflated membrane form offers a means of mass producing small- to intermediate-sized domes which can be relocated for multiple usage. The stationary ring form with an inflated membrane can be used to form small domes for relocation to use sites. The sectionalized ring beam and inflated membrane can be used to make large domes that will remain at a site. The ring sections and membranes can be easily transported to other erection sites.

The cost of materials for shelter construction using foam materials is low—about \$1 to \$1.90/sq ft ($\$10.76$ to $\$20.45/\text{m}^2$) of floor space. Heating and cooling energy requirements of such shelters should also be very low because of the foam's insulating qualities.

Logistics savings for shelter materials can be significant. A 28-ft (8.5-m) diameter dome can be erected from liquid foam materials that weigh about 1500 lb (680 kg) and occupy only about 30 cu ft (0.8 m^3) of shipping volume.

Adequate fire protection can be afforded by application of a mortar coating composed of cement, sand, lime, and water, all of which are readily available in the TO.

It is recommended that the techniques described be added to the appropriate technical manuals and training doctrine, and that necessary forms, equipment, and materials be added to the inventory to allow implementation of these methods of construction.

APPENDIX A: POLYURETHANE FOAMS AND FOAM SYSTEMS

Formation

Polyurethane foams result from a set of carefully controlled chemical reactions and physical phenomena. This section describes the materials and reactions used in forming polyurethane foams.

"Polyurethane" refers to a family of polymers based on the reaction of an isocyanate group with some other reactive group, particularly the hydroxyl group. The resulting polymer is not a foam; it may be in any form from a soft, flexible rubber to a hard, glassy material. Polyurethane foams are formed by generating a gas within the polymer as polymerization reactions occur. The gas forms bubbles which are entrapped until the polymer is completely formed, resulting in a cellular structure.

The gases generated in a foam polyurethane mixture arise from (1) reaction of a calculated amount of water with an equivalent excess of isocyanate (above that required for the polymer) proceeding through several steps and ultimately producing carbon dioxide gas or, (2) including in the mixture a predetermined amount of a low boiling point liquid such as a halocarbon (Freon), which is volatilized by the heat from the exothermic polymerization reactions, thus creating a gas which is trapped in the polymer mass.

The constituents of a typical polyurethane foam mixture include:

1. Isocyanate. The isocyanate group consists of $R - N = C = O$, in which the single bond from the N is attached to a larger molecule R. In order for polymer chain growth to occur, two or more isocyanate groups must be attached to each larger molecule.
2. Polyol. Often referred to as the "resin," it consists of $R' - OH$ groups attached to a larger molecule R' . As with the isocyanate, it is necessary for two or more OH groups to be attached to the same molecule for the polymer molecule to grow to great length.
3. A foaming agent—either water or halocarbon as previously described.
4. A cell control agent or surfactant is usually required to modify the viscosity and/or surface tension of the mixture to insure that gases formed are trapped

and retained and that the bubbles will generally be of the same size. Certain detergents and silicone oils are used widely as surfactants.

5. Catalysts are used to regulate the start and the rates of reactions leading to the polyurethane polymer. Often two or more catalysts are required to achieve the desired results. When water is included in the formulation to cause foaming, a catalyst favoring a water-isocyanate reaction is required.

6. Flame retardants of phosphate character, antimony oxide, chlorine, or bromine are frequently used to reduce the foam's ease of ignition or rate of burning. They will not, however, prevent burning of the foam in a sustained fire. The high surface-to-volume ratios of foams tend to increase flammability problems.

When the materials listed above are mixed in the proper proportions, reactions typified by

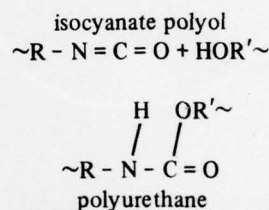

occur. The resulting group is called a urethane. Formation of many such groups results in a polymer network. The average chain-to-chain connection (crosslink density) and the average distance between urethane groups gives the final polymer its rigidity properties.

The amount of gas formed determines the density of the foam; density may be varied from about 1.5 to 50 lb/cu ft (24 to 980 kg/m³).

Physical Properties

The foam's physical properties depend on rigidity and density. Commercial foam systems are normally preblended into two materials— isocyanate and resin blend (polyol, surfactant, blowing agent and catalyst) designed to give 2 lb/cu ft (32 kg/m³) density foams. This combination yields foams that have the typical properties listed in Table A1.

These values in Table A1 can be used for estimating purposes. Since these properties are considered typical, however, a particular foam system should be specifically evaluated for a particular application.

Table A1
Typical Properties of Commercial Foam Systems

Density, lb/cu ft (kg/m ³)	2.0	(32)
Compressive Strength (10% strain), psi (kPa)	35	(241)
Compressive Modules, psi (kPa)	1000	(6895)
Tensile Strength, psi (kPa)	38	(262)
Shear Strength, psi (kPa)	25	(172)
Shear Modulus, psi (kPa)	400	(2758)
K Factor, Btu/hr/sq ft/F/in. (W/m·K)	.12 Btu	(0.02)
Water Absorption, lb/sq ft (kg/m ²)	0.033	(0.161)
Maximum Service Temperature, °F (°C)	200 - 250	(93 - 121)
Coefficient of Linear Expansion, in./in./°F (mm/mm/°C)	6×10^{-5}	(1.1×10^{-4})

Higher density foams are generally stronger structurally but have poorer insulating qualities.

Cost

In general, commercial foam systems for 2 lb/cu ft (32 kg/m³) foam cost between \$.60 and \$.70/lb (\$1.32 and \$1.54/kg). Special formulations may cost more, and a premium is usually added for small quantity orders. Since the isocyanate and resin are derived from petroleum or natural gas, the price may vary accordingly.

Shelf Life

The effective shelf life of a foam system depends largely upon two things—storage conditions and catalyst deterioration. Storage conditions will shorten the shelf life if the materials are stored at either extreme of the optimum storage temperature range—50° to 90°F (11° to 32°C). More critical is the deterioration of the catalyst in the resin blend. If long storage is anticipated, the catalyst should not be blended in until ready for use, and the entire resin blend should be agitated and stirred thoroughly.

Most commercial formulations are guaranteed for at least 6 months in original unopened containers. Many foam systems are dependable for much longer than that—in some cases up to 3 or 4 years.

Sources

There are numerous producers of polyurethane foam systems in the United States.

APPENDIX B: POLYURETHANE FOAM MIXING EQUIPMENT

Generating a good quality foam requires that the foam system components be properly mixed in the proper proportions. Improperly mixed foams may appear to be good but not be stable over a long period of time, or they may not possess the desired strength or insulative qualities.

Numerous manufacturers of paint-spraying equipment have made and sold foam-spraying equipment. Foam-spraying equipment, however, is considerably more complex and requires better maintenance than does paint-spraying equipment. Since isocyanates react with moisture in the air, the equipment must be cleaned after each spray period.

Basically, a foam-spraying machine must do several things: (1) it must accurately and dependably deliver the foam material components in the proper proportions; (2) it must provide adequate mixing to assure near homogeneity of the blend, and (3) it must be manageable by an operator; i.e., the operator must be able to spray the mixed material without excessive difficulty.

Both portable and "stationary" units are commercially available. Most models can accommodate up to 150 ft (45 m) of spray hose. Additional features may be incorporated into the machine design. Heaters may be provided to raise the material temperature. Hoses may also be heated and/or insulated. Some circumstances (spraying foam in cold weather) may make such features necessities rather than optional items.

Figure B1 shows a typical foam sprayer in schematic form (also see Figure 13). Table B1 provides a partial list of companies which market equipment and can provide information concerning operation, cost, and maintenance. Most sprayers require compressed air at the rate of about 15 cfm (0.42 m³/minute) at 100 psi (689 kPa) pressure and 220 V, single-phase electrical power.

While foam spraying is relatively straightforward, operators should be trained in the proper use and maintenance of the equipment. Normally, a 1-week course can provide all necessary training in setup, operation, troubleshooting, and maintenance procedures.

Maintaining a ready supply of repair and/or replacement parts is advisable to avoid downtime in case of a malfunction. Experienced manufacturers are aware of the more common high-mortality parts and can suggest a basic stockage list. They also usually offer quick response to orders for repair parts. Proper training will provide the operator with enough knowledge to replace parts as needed.

The industrial/commercial users of spray foam equipment recommend purchasing and maintaining the simplest piece of equipment capable of doing the desired job. Options on the machine can often cause problems in handling, operation, and maintenance. In addition, these options may represent a substantial increase in the original cost of the equipment.

Table B1
Partial List of Foam Spray Equipment Manufacturers

Accuratio Systems, Inc.
1472 South Floyd St
Louisville, KY 40208

Admiral Equipment Division
Upjohn Co.
305 West North St
Akron, OH 44303

Binks Manufacturing Co.
Plastic & Resin Equipment Division
9201 West Belmont Ave
Franklin Park, IL 60131

Glas-Craft of California
9145 Glenoaks Blvd
Sun Valley, CA 91352

Graco, Inc.
60 Eleventh Ave, NE
Minneapolis, MN 55441

Gusmer Corp.
P.O. Box 164
414 Rt. 18 Spring Valley Rd
Old Bridge, NJ 08857

North American Urethanes, Inc.
Keytum Engineering Division
1717 Boettler Rd
Uniontown, OH 44685

The Martin Sweets Co., Inc.
3131 W. Market St
Louisville, KY 40212

Venus Products, Inc.
1862 Ives Ave
Kent, WA 98501

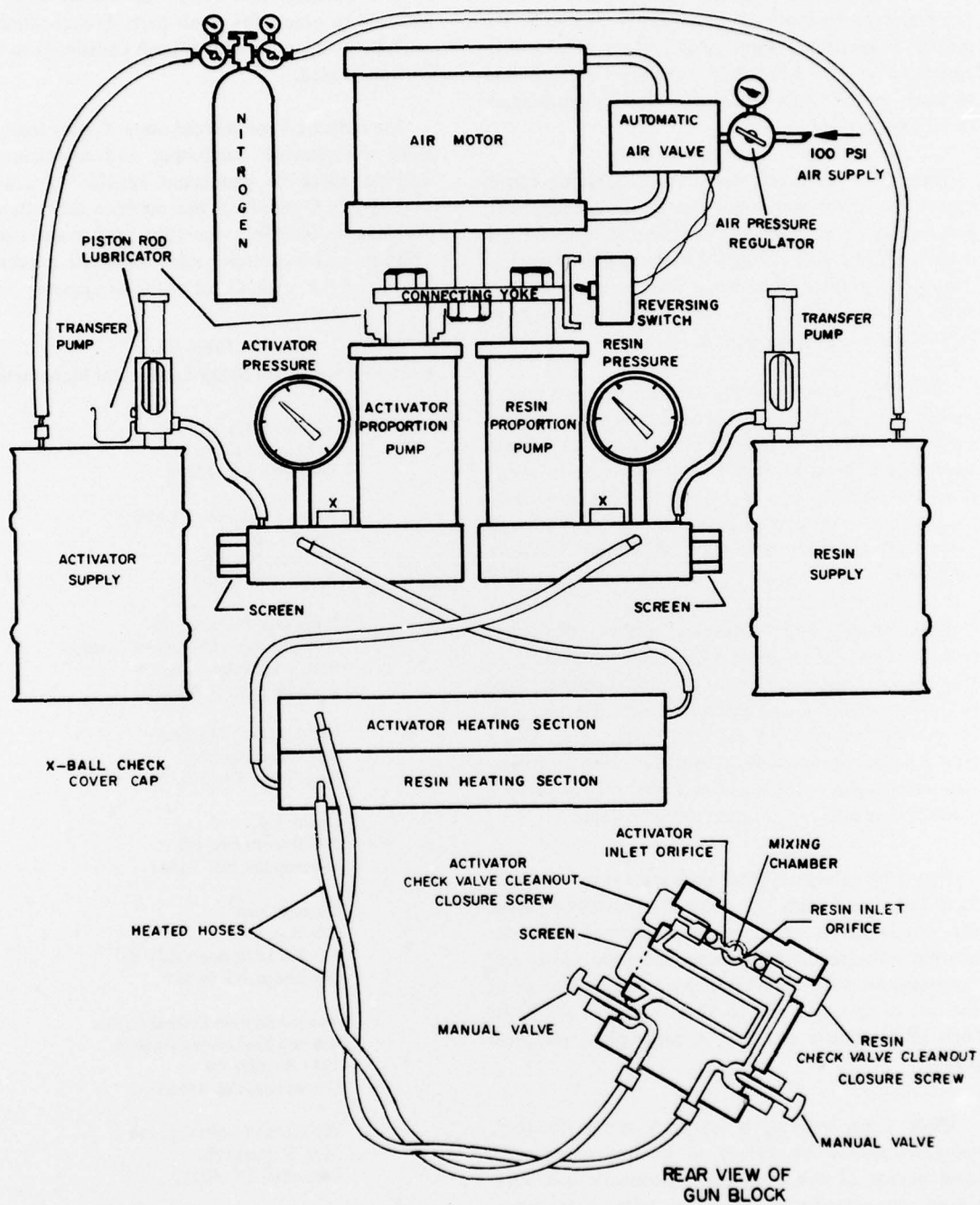

Figure B1. Basic component schematic (spray equipment). This model is manufactured by Gusmer Corporation.

Spray foam equipment usually costs from \$3000 to \$10,000, depending on the volume capability and the extra items included.

Foam production capability ranges from about 2 to about 20 lb/minute (0.9 to 9.1 kg/minute). Larger outputs are possible, but may cause problems, in that the operator may not be able to move about fast enough to make full use of the output. For example, a 20 lb/minute (9.1 kg/minute) machine can produce 10 cu ft (0.28 m³) of 2 lb/cu ft (32 kg/m³) foam per minute. If a 1-in. (25 mm) layer is being applied, the 10 cu ft (0.28 m³) would cover an area of about 60 sq ft/minute (5.6 m³/minute) of operation. Area coverage at this rate would obviously require frequent movement. A good, practical output is about 8 to 10 lb/minute (3.6 to 4.5 kg/minute), representing 25 to 30 sq ft/minute (2.3 to 2.8 m²) of coverage.

REFERENCES

- Becker, Walter E., *U. S. Sandwich Panel Manufacturing/Marketing Guide* (Technomic Publishing Co., 1968).
- Paraskevopoulos, Stephen C. A., *Architectural Research on Structural Potential of Foamed Plastics for Housing in Underdeveloped Areas* (Architectural Research Laboratory, The University of Michigan, 1965).
- Smith, Alvin, *Fire/Flammability Test of Polyurethane Foams and Protective Coatings*, Technical Report M-129/ADA028386 (U. S. Army Construction Engineering Research Laboratory [CERL], 1976).
- Smith, Alvin, *Size and Shape Limitations of Foam Structures*, Draft Technical Report (CERL, 1977).
- Spiral Generation of Domes* (The Dow Chemical Co., 1959).

CERL DISTRIBUTION

Picatinny Arsenal
ATTN: SMUPA-VP3

US Army, Europe
ATTN: AEAE

Director of Facilities Engineering
APO New York, NY 09827
APO Seattle, WA 98749

DARCOM STIT-EUR
APO New York 09710

USA Liaison Detachment
ATTN: Library
New York, NY 10007

US Military Academy
ATTN: Dept of Mechanics
ATTN: Library

Chief of Engineers
ATTN: Tech Monitor
ATTN: DAEN-ASL-L (2)
ATTN: DAEN-FEE-A
ATTN: DAEN-FEB
ATTN: DAEN-FEZ-A
ATTN: DAEN-MCZ-S (2)
ATTN: DAEN-RDL
ATTN: DAEN-ZCP
ATTN: DAEN-PMS (12)
for forwarding to
National Defense Headquarters
Director General of Construction
Ottawa, Ontario K1A0K2
Canada

Canadian Forces Liaison Officer (4)
U.S. Army Mobility Equipment
Research and Development Command
Ft Belvoir, VA 22060

Div of Bldg Research
National Research Council
Montreal Road
Ottawa, Ontario, K1A0R6

Airports and Const. Services Dir.
Technical Information Reference
Centre
KAOL, Transport Canada Building
Place de Ville, Ottawa, Ontario
Canada, K1A 0N8

British Liaison Officer (5)
U.S. Army Mobility Equipment
Research and Development Center
Ft Belvoir, VA 22060

Ft Belvoir, VA 22060
ATTN: ATSE-TD-TL (2)
ATTN: Learning Resources Center
ATTN: Kingman Bldg, Library
ATTN: FESA

US Army Foreign Science &
Tech Center
ATTN: Charlottesville, VA 22901
ATTN: Far East Office

Ft Monroe, VA 23651
ATTN: ATEN
ATTN: ATEN-FE-BG (2)

Ft McPherson, GA 30330
ATTN: AFEN-FEB

Ft Lee, VA 23801
ATTN: DRXMC-D (2)

USA-CRREL

USA-WES
ATTN: Concrete Lab
ATTN: Soils & Pavements Lab
ATTN: Library

6th US Army
ATTN: AFKC-LG-E

I Corps (ROK/US) Group
ATTN: EACI-EN
APO San Francisco 96358

US Army Engineer District
New York
ATTN: Chief, Design Br
Buffalo
ATTN: Library
Saudi Arabia
ATTN: Library

US Army Engineer District
Pittsburgh
ATTN: Library
ATTN: ORPCD
ATTN: Chief, Engr Div
Philadelphia
ATTN: Library
ATTN: Chief, NAPEN-D
Baltimore
ATTN: Library
ATTN: Chief, Engr Div
Norfolk
ATTN: Library
ATTN: NAOEN-D
Huntington
ATTN: Library
ATTN: Chief, ORHED-F
Wilmington
ATTN: Chief, SAWCO-C
Charleston
ATTN: Chief, Engr Div
Savannah
ATTN: Library
ATTN: Chief, SASAS-L
Jacksonville
ATTN: Library
ATTN: Const. Div
Mobile
ATTN: Library
ATTN: Chief, SAMEN-D
ATTN: Chief, SAMEH-F
Nashville
ATTN: Chief, ORNED-F
Memphis
ATTN: Chief, Const. Div
ATTN: Chief, LMED-D
Vicksburg
ATTN: Chief, Engr Div
Louisville
ATTN: Chief, Engr Div
Detroit
ATTN: Library
ATTN: Chief, NCEED-T
St. Paul
ATTN: Chief, ED-D
ATTN: Chief, ED-F
Chicago
ATTN: Chief, NCCCO-C
ATTN: Chief, NCCED-F
Rock Island
ATTN: Library
ATTN: Chief, Engr Div
ATTN: Chief, NCREG-F
St. Louis
ATTN: Library
ATTN: Chief, ED-D
Kansas City
ATTN: Library (2)
ATTN: Chief, Engr Div
Omaha
ATTN: Chief, Engr Div
New Orleans
ATTN: Library (2)
ATTN: Chief, LMED-DG
Little Rock
ATTN: Chief, Engr Div
Tulsa
ATTN: Library
Fort Worth
ATTN: Library
ATTN: SWFED-D
ATTN: SWFED-F
Galveston
ATTN: Chief, SWGAS-L
ATTN: Chief, SWGCO-C
ATTN: Chief, SWGED-DC
Albuquerque
ATTN: Library
ATTN: Chief, Engr Div
Los Angeles
ATTN: Library
ATTN: Chief, SPLED-F
San Francisco
ATTN: Chief, Engr Div
Sacramento
ATTN: Chief, SPKED-D
ATTN: Chief, SPKCO-C
Far East
ATTN: Chief, Engr Div
Japan
ATTN: Library
Portland
ATTN: Library
ATTN: Chief, DB-6
ATTN: Chief, FM-1
ATTN: Chief, FM-2
Seattle
ATTN: Chief, NPSCO
ATTN: Chief, NPSEN-FM
ATTN: Chief, EN-VR-ST

US Army Engineer District
Walla Walla
ATTN: Library
ATTN: Chief, Engr Div
Alaska
ATTN: Library
ATTN: NPADE-R

US Army Engineer Division
Europe
ATTN: Technical Library
New England
ATTN: Library
ATTN: Laboratory
ATTN: Chief, NEDCD
North Atlantic
ATTN: Library
ATTN: Chief, NADEN
South Atlantic
ATTN: Library
ATTN: Laboratory
ATTN: Chief, SADEN-TC
Huntsville
ATTN: Library (2)
ATTN: Chief, HNDED-CS
ATTN: Chief, HNDED-SR
Lower Mississippi
ATTN: Library
ATTN: Chief, LMVED-G
Ohio River
ATTN: Laboratory
ATTN: Chief, Engr Div
ATTN: Library
North Central
ATTN: Library
Missouri River
ATTN: Library (2)
ATTN: Chief, MRDED-G
ATTN: Laboratory
Southwestern
ATTN: Library
ATTN: Laboratory
ATTN: Chief, SWDED-TG
South Pacific
ATTN: Laboratory
Pacific Ocean
ATTN: Chief, Engr Div
ATTN: FM&S Branch
ATTN: Chief, PODED-D
North Pacific
ATTN: Laboratory
ATTN: Chief, Engr Div

Facilities Engineer
FORSCOM
Ft Devens, MA 01433
Ft McPherson, GA 30330
Ft Sam Houston, TX 78234
Ft Carson, CO 80913
Ft Campbell, KY 42223
Ft Hood, TX 76544
Ft Lewis, WA 98433
TRADOC
Ft Dix, NJ 08640
Ft Monroe, VA 23651
Ft Lee, VA 23801
Ft Gordon, GA 30905
Ft McClellan, AL 36201
Ft Knox, KY 40121
Ft Benjamin Harrison, IN 46216
Ft Leonard Wood, MO 65473
Ft Sill, OK 73503
Ft Bliss, TX 79916
HQ, 24th Inf, Ft Stewart, GA 31313
HQ, 1st Inf, Ft Riley, KS 66442
HQ, 5th Inf, Ft Polk, LA 71459
HQ, 7th Inf, Ft Ord, CA 93941
West Point, NY 10996
ATTN: MAEN-E
Ft Benning, GA 31905
ATTN: ATZB-FE-EP
ATTN: ATZB-FE-BG
CAC&FL
ATTN: DFAE (3)
Ft Leavenworth, KS 66027
AMC
Dugway, UT 84022
USACC
Ft Huachuca, AZ 85613

AF/PREEU
Bolling AFB, DC 20332

AF Civil Engr Center/XRL
Tyndall AFB, FL 32401

Little Rock AFB
ATTN: 314/DEEE/Mr. Gillham

MSC

Naval Facilities Engr Command
ATTN: Code 04
Alexandria, VA 22332

Port Hueneme, CA 93043
ATTN: Library (Code LO8A)
ATTN: Morrell Library

Defense Documentation Center (12)

Washington, DC
ATTN: Bldg Research Advisory Board
ATTN: Library of Congress (2)
ATTN: Federal Aviation Administration
ATTN: Dept of Transportation Library
ATTN: Transportation Research Board

Engineering Societies Library
New York, NY 10017