

AD-A044 999

MARINCO LTD FALLS CHURCH VA

F/G 13/3

FABRICATION AND TESTS OF THE PROTOTYPE SURFACE/SHALLOW-SUBSURFA--ETC(U)

AUG 77 R C MOORE

N00174-76-C-0099

UNCLASSIFIED

103F

NAVEODFAC-TR-184

NL

| OF |
AD
A044 999



END
DATE
FILMED
11-77
DDC

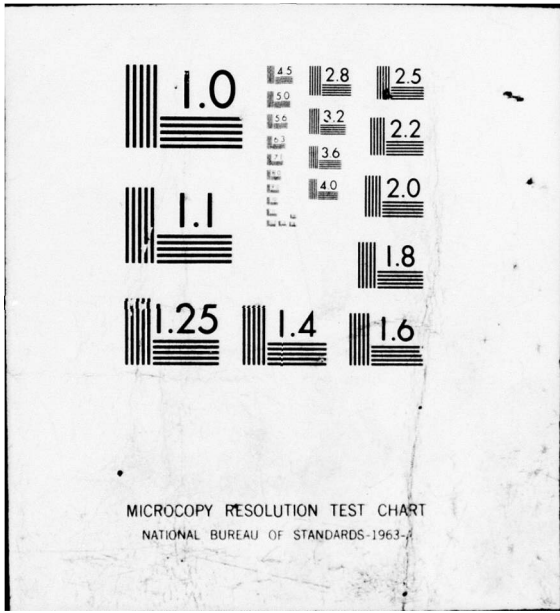

AD A 044999

NAVEODFAC TECHNICAL REPORT TR-184

**FABRICATION AND TESTS OF THE PROTOTYPE
SURFACE/SHALLOW-SUBSURFACE
CLEARANCE VEHICLE (SSCV)**

by

Robert C. Moore

Marinco, Ltd.

Falls Church, VA 22044

AUGUST 1977

FINAL REPORT

Approved for public release; distribution unlimited.

Prepared for
NAVAL EXPLOSIVE ORDNANCE DISPOSAL FACILITY
Indian Head, Maryland 20640

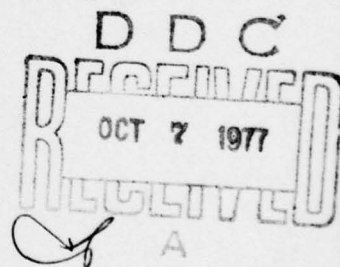

AD No. _____
DDC FILE COPY

Released by
LIONEL A. DICKINSON
Technical Director

Under Authority of
W. S. CADOW, JR., CDR, USN
Commanding Officer

Unclassified

SECURITY CLASSIFICATION OF THIS PAGE (When Data Entered)

REPORT DOCUMENTATION PAGE		READ INSTRUCTIONS BEFORE COMPLETING FORM	
1. REPORT NUMBER 19 TR-184	2. GOVT ACCESSION NO. 18 NAVFODFAC	3. RECIPIENT'S CATALOG NUMBER 9	
4. TITLE (and Subtitle) 6 FABRICATION AND TESTS OF THE PROTOTYPE SURFACE/SHALLOW-SUBSURFACE CLEARANCE VEHICLE (SSCV)		5. TYPE OF REPORT & PERIOD COVERED FINAL REPORT, 1 Dec 75 through 10 Feb 77	
7. AUTHOR(s) 10 Robert C. Moore		6. PERFORMING ORG. REPORT NUMBER 14 103F	8. CONTRACT OR GRANT NUMBER(s) 15 N00174-76-C-0099
9. PERFORMING ORGANIZATION NAME AND ADDRESS Marinco, Ltd. <i>new</i> Falls Church, VA 22044		10. PROGRAM ELEMENT, PROJECT, TASK AREA & WORK UNIT NUMBERS 62734N-SF-34-373-302	
11. CONTROLLING OFFICE NAME AND ADDRESS Naval Explosive Ordnance Disposal Facility Code 504 Indian Head, MD 20640		12. REPORT DATE 11 August 1977	13. NUMBER OF PAGES 61
14. MONITORING AGENCY NAME & ADDRESS (if different from Controlling Office) 12 61p.		15. SECURITY CLASS. (of this report) UNCLASSIFIED	
16. DISTRIBUTION STATEMENT (of this Report) Approved for public release; distribution unlimited.		15a. DECLASSIFICATION/DOWNGRADING SCHEDULE N/A	
17. DISTRIBUTION STATEMENT (of the abstract entered in Block 20, if different from Report)		16 F34373 17 SF34373302	
18. SUPPLEMENTARY NOTES			
19. KEY WORDS (Continue on reverse side if necessary and identify by block number) decontamination pneumatic explosive ordnance disposal range clearance explosives remote control hydraulic			
20. ABSTRACT (Continue on reverse side if necessary and identify by block number) The prototype Surface/Shallow-subsurface Clearance Vehicle (SSCV) was built and tested to demonstrate a practical, mechanized technique for clearing ordnance impact ranges. The clearance vehicle and its prime mover, a TD-20 Bulldozer, were successfully operated by remote control. This report describes the design, construction and tests of the SSCV. Modifications that were made to improve the operation of the vehicle are described as well as the subsequent testing of the vehicle after each modification phase.			

DD FORM 1473

EDITION OF 1 NOV 65 IS OBSOLETE
S. N. 0302-104-6601

Unclassified

SECURITY CLASSIFICATION OF THIS PAGE (When Data Entered)

410 417

LB

SECURITY CLASSIFICATION OF THIS PAGE(When Data Entered)

A large, empty rectangular box with a black border, occupying most of the page. It is intended for the user to enter the security classification of the page when data is entered.

SECURITY CLASSIFICATION OF THIS PAGE(When Data Entered)

PREFACE

The Explosive Ordnance Disposal (EOD) Detachment, Cecil Field, assisted with the vehicle modification and test phases of this program at the Pinecastle Electronic Warfare Range, Florida. The valuable support rendered by the EOD Detachment was an important factor in the accomplishment of project objectives. The skilled effort and advice received from the detachment are greatly appreciated by the NAVEODFAC engineers E. Faccini, J. Petrousky, and L. Vipond and by the Marineco project personnel.

In addition, recognition is given to the officers and personnel at the Pinecastle Electronic Warfare Range for the outstanding cooperation extended to this project during the vehicle tests on the impact range.

ACCESSION No.	
RTIC	INFO Section <input checked="" type="checkbox"/>
DCC	DOC Section <input type="checkbox"/>
UNANNOUNCED	<input type="checkbox"/>
JUSTIFICATION	
BY	
DISTRIBUTION/AVAILABILITY CODES	
DMR	AVAIL and/or SPECIAL
A	

TABLE OF CONTENTS

	<u>Page</u>
SUMMARY	1
INTRODUCTION	2
Purpose	2
Background	2
Description of Tasks	3
DESIGN AND FABRICATION	4
Design	4
Fabrication	12
TESTS AND MODIFICATIONS	12
Preliminary Tests	12
Initial Field Test	14
Phase I Modifications and Follow-on Tests	27
Phase II Modifications and Final Tests	34
CONSIDERATIONS FOR SECOND GENERATION DESIGN	47
CONCLUSIONS	48
Feasibility of Mechanizing Impact Range Clearance	48
Reliability	50
APPENDIX - DESIGN OF A SECOND GENERATION SURFACE/ SHALLOW-SUBSURFACE CLEARANCE VEHICLE - SSCV MOD 1	A-1

LIST OF ILLUSTRATIONS

<u>Figure No.</u>		<u>Page</u>
1	Representation of SSCV design.	5
2	Relationship of SSCV conveyors; left half is shown.	7
3	Master Control Box mounted on prime mover.	9
4	Interior of Master Control Box.	9
5	Cam-actuated switches controlling prime mover turns.	10
6	Air compressor and air tank on the SSCV.	11
7	Breakaway connection in umbilical air hose.	11
8	Hydraulic pump, reservoir, and manifold mounted on the SSCV.	13
9	Pinecastle target complex.	16
10	Repaired support for hydraulic cylinder.	17
11	Threaded rod used as shearpin on SSCV hitch.	17
12	Rope harness used to facilitate quick-release of control cable.	18
13	Microswitches mounted on cams in the Master Control Box.	18
14	Ground cover along the run-in line between the Main Bull and Live Ordnance Impact Area.	21
15	Debris and ordnance dumped from the SSCV hopper.	21
16	Prybar used to release jam in the Draper chain.	22
17	Clearance of the run-in line road between the Main Bull and the Live Ordnance Impact Area.	22
18	Draper chain sections bent by severe jam in the main conveyor.	24
19	Bent Draper sections removed from the main conveyor.	24
20	Slip clutch on main conveyor drive.	29
21	Practice bomb jammed in front of main conveyor.	29
22	Fractured drive roller from SSCV soil conveyor.	31
23	MK 82 (500-lb.) bomb dug up and loaded into SSCV hopper.	31
24	Modification made to SSCV digging platform to eliminate jams caused by practice bombs.	32
25	Self-level sensor box mounted on the front of the SSCV frame.	36

LIST OF ILLUSTRATIONS - Continued

<u>Figure No.</u>		<u>Page</u>
26	Axle tilting mechanism mounted on SSCV axle; self-level cylinder is fastened to the right side of the axle.	37
27	Hydraulic cylinder mounted on the left side of the SSCV hopper.	38
28	Towbar assembly, with spring-loaded hitch, attached to the front of the SSCV.	40
29	Hydraulic manifold, with three solenoid-actuated valves, mounted on the SSCV.	41
30	Minimum altitude release target; area for final test of modified SSCV.	43
31	Spring-loaded hitch after failure of retaining pin.	44
32	Fractured retaining pin from spring-loaded hitch.	44
A-1	SSCV, Mod 1.	A-2

SUMMARY

The Prototype Surface/Shallow-subsurface Clearance Vehicle (SSCV) was designed and constructed to test and demonstrate the practicality of applying mechanized techniques to the task of clearing ordnance impact ranges. The vehicle was built to perform a number of the labor-intensive, and sometimes hazardous, tasks that are currently performed with hand tools and light vehicles.

A remote-control capability was provided through use of RF remote control equipment. This equipment is used with model airplanes but has the configuration and versatility for application to the SSCV concept. The operational functions of the SSCV and maneuvering of the prime mover, which towed the SSCV, were remotely controlled.

After conduction of the first field test on the Pinecastle Electronic Warfare Range, Astor, Florida, modifications were made to the SSCV to improve its operation and to test additional concepts that may be incorporated in extended development of clearance vehicles. The subsequent tests of these modifications are described in this report and the results are evaluated. The field tests indicated that the SSCV met the design goals of handling ordnance and debris from 40-mm to 1.22-meter lengths, effectively separating soil and sand from the ordnance and debris. The remote control of the SSCV and prime mover was successfully demonstrated; it was shown that additional fail-safe features should be incorporated in the system operation. The effective digging depth of the SSCV was approximately 9 inches per sweep. Some tests were conducted at 10 to 12 inches but the sorting efficiency was somewhat reduced. Efficiency of the SSCV was also shown to be significantly affected by the amount of moisture in the soil. When digging in wet sand or soil, the depth of cut had to be reduced.

Appended to this report is the recommended design for a second-generation SSCV. This design is based on the lessons learned in the test and evaluation of the SSCV Prototype. The second-generation design is approximately 50 percent larger in all dimensions than the prototype model. The new design would move on free-wheeling tracks, in place of the wheels used on the prototype. The gasoline-engine driven conveyor system on the prototype is replaced by hydrostatic drive on the second generation vehicle. Because of the increased physical size, the new design allows the handling of larger items of debris and ordnance and a significant increase in hopper capacity.

INTRODUCTION

PURPOSE

The Prototype Surface/Shallow-subsurface Clearance Vehicle (SSCV) was built and tested to demonstrate the feasibility of mechanizing some aspects of clearing ordnance impact ranges. Present range clearance procedures require a prohibitive amount of manpower to locate, remove, and dispose of ordnance and debris. In many cases, clearance operations require the exposure of personnel to unexploded ordnance (UXO). The objectives of the SSCV Prototype design were to provide a technique whereby a variety of weights, sizes, shapes, and composition of ordnance could be safely and efficiently collected and removed from the impact areas.

BACKGROUND

For several years, Maringo, Ltd., has been involved in the investigation and survey of conditions on ordnance impact ranges. These extensive assessments of contaminated areas lead to the conclusion that a properly designed vehicle could perform many clearance tasks that are now personnel-intensive.¹ Many impact range areas are on reasonably flat land, with sparse vegetation and dry, friable soil or sand. It is also apparent that the large percentage of ordnance contamination consists of the surface items and those shallowly buried. In the event a total decontamination of a range would be required, ordnance detectors/locators would have to be used to find the more deeply buried items. The surface and shallow-subsurface contamination on many ranges precludes the use of detector/locators because of the extensive background "clutter" that the devices would encounter. The SSCV design evolved on the basis that, since a significant amount of the contamination can be removed by digging 12 to 18 inches below the surface, a major portion of the clearance effort can be realized while the more difficult task of deep recovery can be aided.

In a study conducted by Maringo, a system concept was described that employed mechanized means for mass decontamination of ordnance impact ranges.² This concept, called FIRE-CO (Family

¹ NAVEODFAC Technical Report TR-161; *Study on the Feasibility of Mass Area Ordnance Decontamination*; W. E. Webber and R. C. Moore; 15 August 1974.

² NAVEODFAC Technical Report TR-171; *Design Parameters of a Prototype System for Impact Ordnance Range Clearance*; W. E. Webber and R. C. Moore; June 1975.

of Impact Range Equipment for Clearing Ordnance), presented a configuration that would alleviate many of the problems facing operators who must conduct mass decontamination. The SSCV design is an extension of the FIRE-CO concept.

DESCRIPTION OF TASKS

The program tasks are covered in depth in subsequent sections of this report. Briefly, the seven tasks are described below.

Task I - Design. The SSCV design is based on the design parameters previously set forth for FIRE-CO.³ The vehicle frame resembles that of a rock-picker/potato-harvester. Major innovations are in the conveyor system and the operational control. The design is comprised of four subsystems. The Electrical Subsystem includes the control switching circuits for activation of the prime mover and SSCV functions. The Pneumatic Subsystem responds to the remote operator commands for travel and turn control movements on the prime mover. The Hydraulic Subsystem provides the means for performing all the SSCV functions that can be controlled remotely or locally. The Remote Control Subsystem permits operation of the SSCV System from a safe, standoff distance by means of an RF link. The remote control capability was designed to use an off-the-shelf model airplane remote control system and a mechanical interface that perform the necessary functions on the prime mover and the SSCV. Pneumatic cylinders were selected to move the prime mover operator control levers. Hydraulic cylinders were chosen for the SSCV functions.

Task II - Fabrication. The construction of the SSCV took place at Haines Manufacturing in Avoca, New York. Haines Manufacturing was chosen by Marinco as the fabricator because that company is a national producer of customized agricultural machinery and manufactures a rock-picker that conforms to the design of the SSCV. The vehicle was built by Haines Manufacturing according to guidelines provided by Marinco.

Task III - Preliminary Tests. A shakedown test was conducted at the Haines facility in New York. This led to some minor changes in the vehicle structure. The more extensive preliminary tests were carried out at Pinecastle Electronic Warfare Range (PEWR), Astor, Florida, after the SSCV had been transported by Marinco from Avoca, New York. These tests precipitated two phases of modification to the SSCV System.

³ Ibid

Task IV - Phase I Modifications and Tests. The results of the preliminary tests on the Pinecastle range in July 1976 identified changes that should be made in the SSCV System to enhance its capability. The Phase I Modifications were those that could be done with a minimum of change in the SSCV structure and could be simply tested. The modifications and tests were conducted at PEWR.

Task V - Phase II Modifications and Tests. The Phase II modifications involved significant changes in the SSCV hopper door design, the addition of a self-leveling axle mechanism, a longer towbar with a hydraulic jack, a new Master Control Box, addition of an on-board TV monitor, and a number of minor changes. These modifications required a week for completion at PEWR. The modified SSCV System was tested on the Pinecastle Target.

Task VI - Design of a Second Generation SSCV. A larger, improved SSCV will meet the requirement of a demonstration vehicle that can be used on a variety of impact ranges. This advanced design incorporates the modifications to the existing prototype vehicle that were tested successfully at PEWR.

Task VII - Documentation. This task was active through the entire program because it included the bimonthly status reports submitted to NAVEODFAC, the after-action reports on the three field tests conducted at PEWR, and the drawings of the SSCV Prototype System. The operations manual and maintenance manual for the system were written under this task.

DESIGN AND FABRICATION

DESIGN

The design task commenced with a review of the preliminary sketches of vehicle configuration that had evolved from previous studies. Project personnel met with the NAVEODFAC Project Officer and discussed the design goals and operational requirements of the system. From these discussions, a representation of the SSCV was sketched (Figure 1) and attention was turned to the details of component function.

Towbar. It was determined that channel steel would be used for towbar construction. It was to be configured for straight towing by the prime mover. The feasibility of offset (off-center) towing was considered; the decision was made to postpone this as an option for later consideration. A spring-release hitch was selected for use on the towbar. This type of hitch is manufactured by John Deere Company. The spring-release feature allows separation of

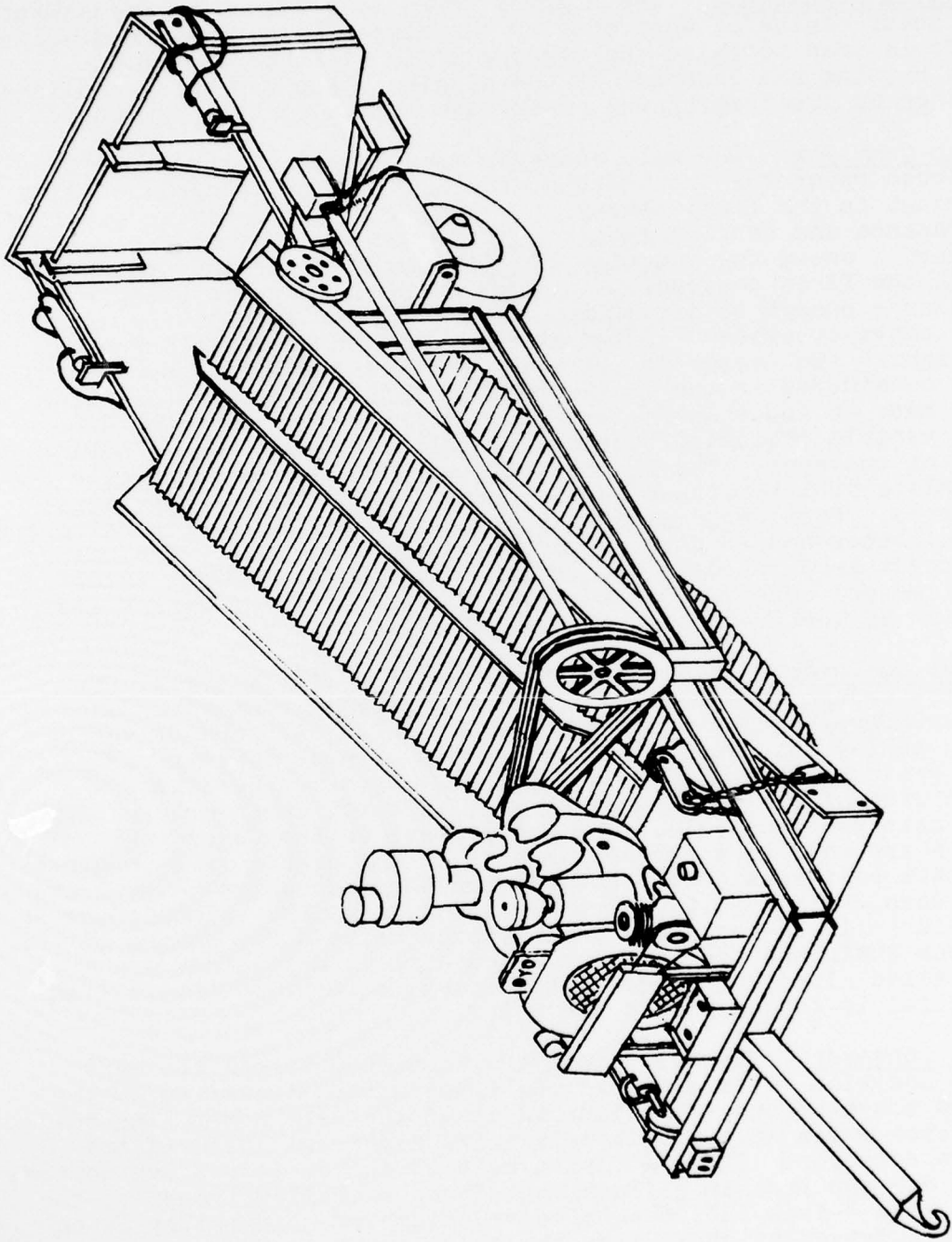

Figure 1. Representation of SSCV Design.

the prime mover from the SSCV when an obstacle is encountered that is beyond the handling capability of the SSCV.

Digging Adjustment. The digging depth is selected by adjustment of heavy chains on each side of the digging platform. Hydraulic lift is used to raise the digging blade clear of the ground. The raising and lowering of the digging blade can be accomplished either by local switching or through remote control commands.

Main Conveyor. The main conveyor must carry all the material scooped up at the front end of the SSCV, allow the soil to sift through to the fines conveyor, and deposit the unsifted material (ordnance and debris) into the hopper on the rear of the vehicle. Figure 2 shows the function of the main conveyor in conjunction with the fines conveyor. The throat at the digging blade must be large enough to accommodate the passage of large items onto the conveyor system. Although the addition of angle iron "flights" (to assist in conveying material up the Draper chain) was considered in the initial design discussions, the decision was made to add this feature only if the preliminary tests of the vehicle indicated that some material had difficulty moving up the conveyor. The Draper chain used on the main conveyor consists of interlinked bars, spaced 1-1/8 inches (2.86 centimeters). Each bar, called a section, is 1/2 inch (1.27 centimeters) in diameter and 28 inches (71.12 centimeters) long. The main conveyor assembly uses two Draper chains with a 2-inch (5.08-centimeter) center ridge separating them. The two chains are driven by sprockets on the same axle.

Fines Conveyor. This conveyor catches the fine material that sifts through the Draper sections of the main conveyor. The fines conveyor consists of two Pylon belts that are driven by head pulleys mounted on separate axles. These separate axles are driven at the same speed, however, by drive sprockets on each side of the vehicle which are, in turn, chain driven from the main conveyor axle. The end pulleys on the fines conveyor belts are self-cleaning and mounted in adjustable take-up blocks so that belt tension can be adjusted when necessary. The belts are each 24 inches (60.96 centimeters) in width. Since there is a 4-inch (10.16-centimeter) difference between the widths of the Draper chain and the fines belt beneath it, deflectors are installed along each side of the fines conveyor so that sifted material is funneled onto the belts.

Soil Conveyor. The soil conveyor is mounted across the SSCV in a position to receive all the fines material carried by the fines conveyor and then windrows it on the left side. The soil conveyor moves at approximately 1-1/2 times the speed of the fines conveyor. It is a Pylon belt 24 inches (60.96 centimeters) in width and runs in a frame that forms a shallow trough on the top. The 4-inch (10.16-centimeter) diameter head pulley is on an axle driven by chain from the drive shaft in the conveyor drive assembly. The self-cleaning end pulley is mounted in take-up blocks.

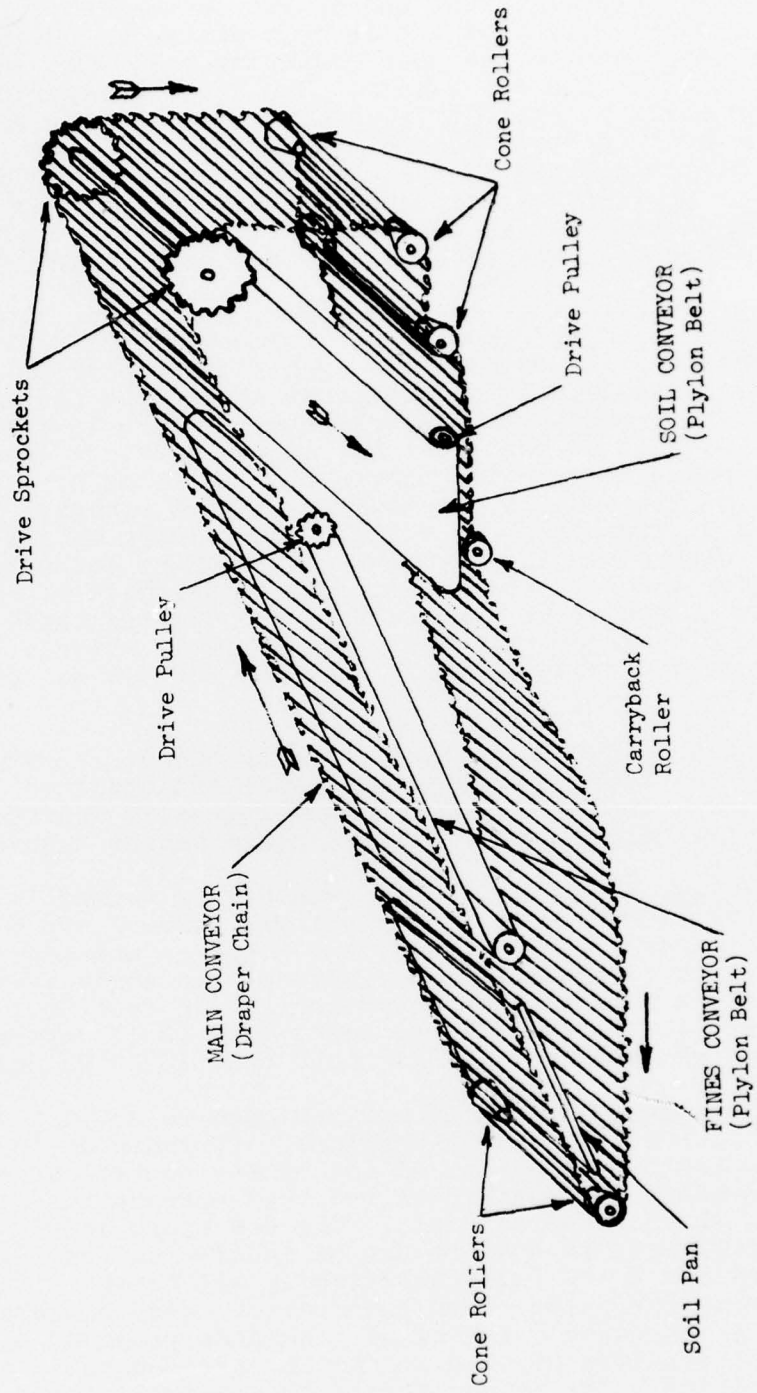

Figure 2. Relationship of SSCV conveyors; left half is shown.

Conveyor Drive Assembly. The driveshaft is connected at one end to the main drive pulley, which is belt-driven by the SSCV engine, and at the other end to the gear reduction box. Two universal joints are used in the driveshaft. The soil conveyor sprocket gear is connected by chain to a sprocket gear on the driveshaft running the soil conveyor at the rpm of the driveshaft. The gear reduction box on the end of the shaft is connected by chain to the sprocket gear on the main conveyor axle. Included in this part of the assembly is an adjustable slip clutch to protect the drive mechanism from damage should a jam occur in the conveyors.

SSCV Engine. A gasoline, 65-horsepower, V4 engine, manufactured by Teledyne Wisconsin, was selected for use on the SSCV Prototype System. This engine provides the mechanical power for the conveyor drive assembly, the hydraulic pump, and the pneumatic pump. The engine incorporates an electric starter; the 12-volt storage battery is mounted on the front end of the SSCV. A 10-gallon (38-liter) gasoline tank was fabricated and is mounted on the left-front of the vehicle. A Rockford clutch assembly is mounted on the rear of the Wisconsin engine. The clutch is operated in two ways: with a manual operating lever and by mechanical linkage to the digger bed lift mechanism. The latter mode of operation permits the clutch to be engaged when the digging blade has been lowered and disengaged when the blade is fully raised, thus stopping the conveyor drive assembly when the SSCV is not digging soil.

Hopper. A 6-ton (5400-kilogram) capacity hopper is mounted on the rear of the SSCV to handle the debris and ordnance on the main conveyor. The hopper door is hydraulically operated and dumping of the hopper contents takes place behind the vehicle.

SSCV Main Frame. The frame of the vehicle is primarily of welded steel construction. The basic structural members are 6-inch (15.24-centimeter) channel beams; the supports and bracing are cut from 3-inch (7.62-centimeter) channel and angle steel. The design resulted in a vehicle approximately 20 feet (6.1 meters) long, 6 feet (1.83 meters) wide, and 7 feet (2.13 meters) high. The total weight was estimated to be 6 tons (5400 kilograms).

Master Control Box. This unit was designed to accomplish all the remote control switching functions. It contains the receiver and servomechanism components of the remote-control subsystem and the solenoid-operated air valves that operate the air cylinders on the prime mover controls. The box shown in Figures 3 and 4 is configured so that it can be mounted on the seat frame of the prime mover and interconnected by air hoses to the cylinders that move the prime mover turn levers, gear range selector, and deceleration pedal. The signal commands received by the remote-control receiver mounted in the box are channeled to the servo mechanisms. The servos rotate in a direction and through

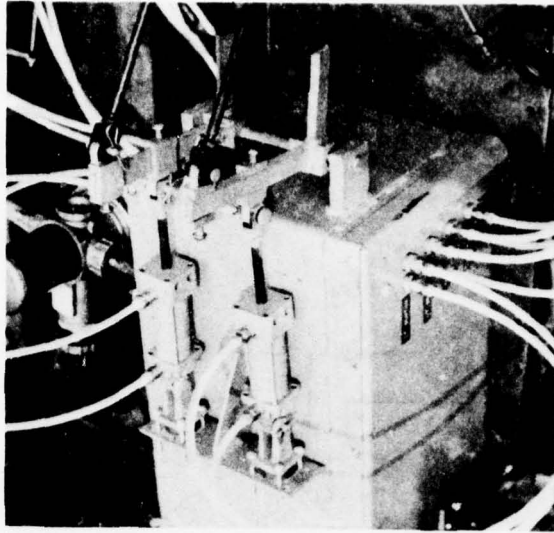

Figure 3. Master Control Box mounted on prime mover.

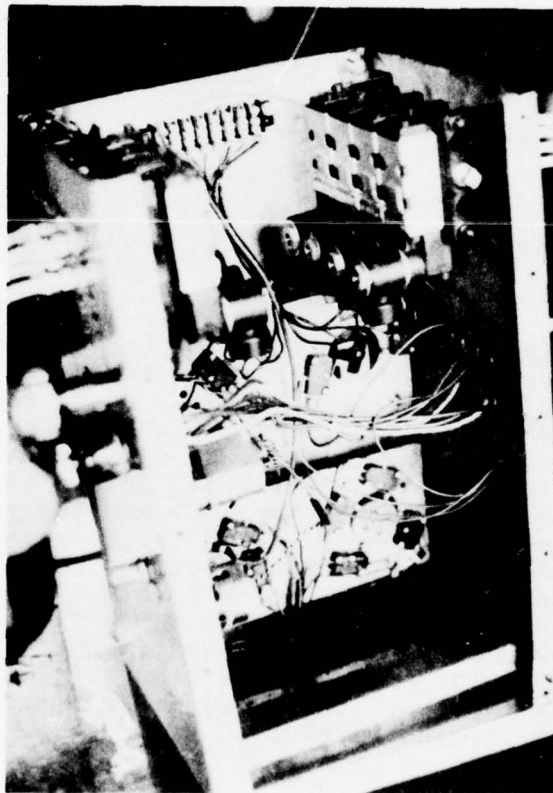

Figure 4. Interior of Master Control Box.

an angle proportional to the transmitter control lever movement, thus rotating the cams mounted on each servo. Figure 5 shows the manner in which the cams actuate the precision switches mounted on their peripheries. The drawing in Figure 5 illustrates the operation of the turn controls on the prime mover but is also representative of all the cam-actuated switch functions in the control box.

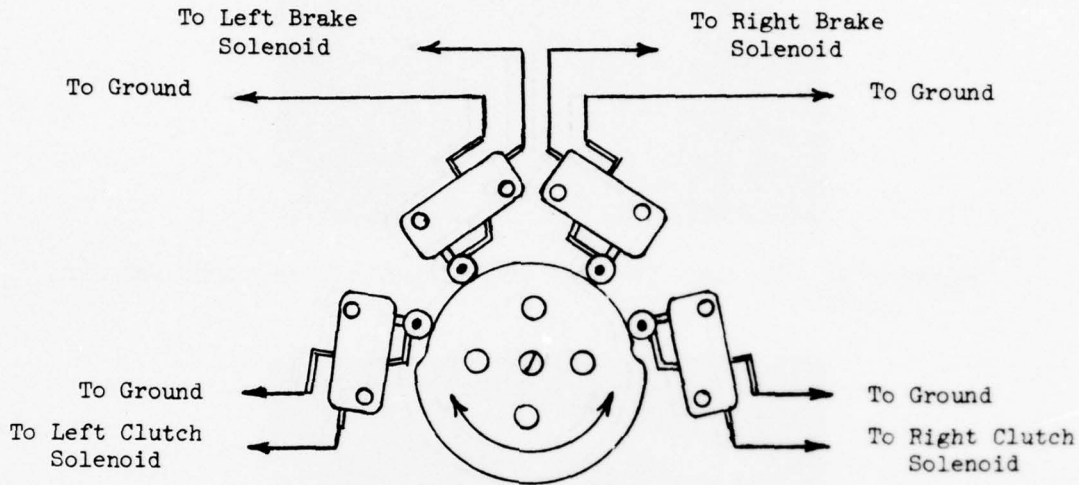

Figure 5. Cam-actuated switches controlling prime mover turns.

Pneumatic Subsystem. Pneumatic (air) control was selected for movement of the operator levers on the prime mover because rapid, positive action to specific lever positions was required. The air compressor was mounted on the SSCV, where it was belt-driven from the SSCV engine. The air tank was also mounted on the SSCV. These components are shown in Figure 6. An air hose was run as an umbilical connection between the SSCV and the prime mover to deliver air pressure to the air valves in the Master Control Box. As a safety measure, a breakaway connection (Figure 7) was provided in the midpoint of the air hose to allow separation in case the towbar should come loose from the prime mover pintle hitch. The solenoid-actuated air valves (mounted in the Master Control Box) control the air pressure to the cylinders on the prime mover control levers. The prime mover functions that are operated by the air cylinders are:

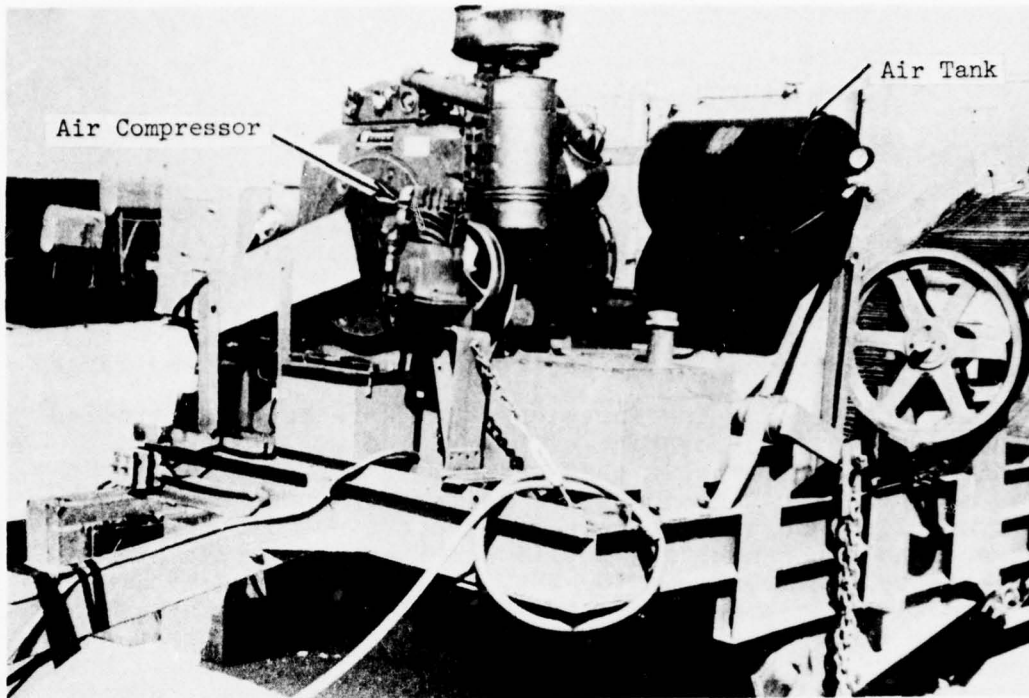

Figure 6. Air compressor and air tank on the SSCV.

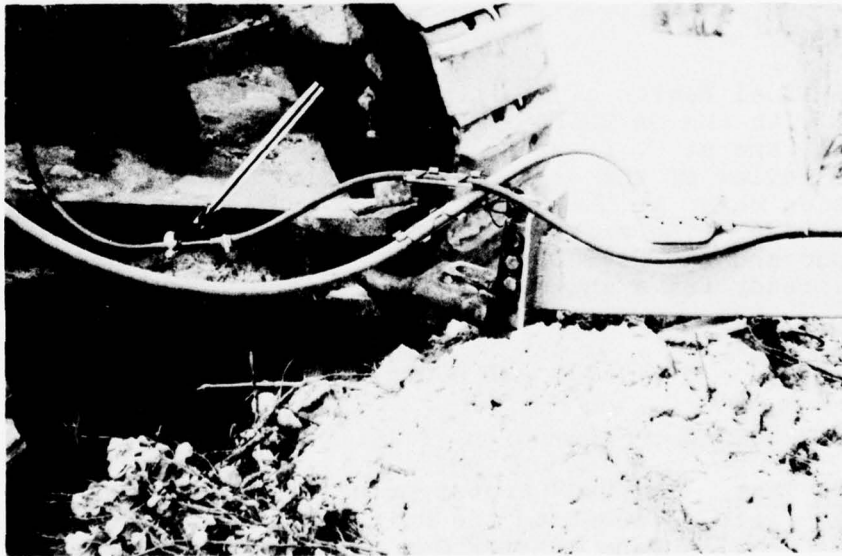

Figure 7. Breakaway connection in umbilical air hose.

- Right clutch (feathered turn)
- Right brake (pivot turn)
- Left clutch (feathered turn)
- Left brake (pivot turn)
- Deceleration/acceleration pedal
- Gear range selection (neutral, 1st range, 2nd range)

Hydraulic Subsystem. The functions that were to be controlled on the SSCV required movement of heavy mechanical assemblies, but not the rapid response that was needed for control of the prime mover. Hydraulic power was suited for these operations. The hydraulic subsystem is completely contained on the SSCV. Figure 8 shows the mounting positions of the hydraulic pump (which is belt-driven from the SSCV engine), the reservoir, and the manifold with the valves that control the digger assembly and hopper door. Local control of the valve solenoids is obtained by use of the toggle switches on the Local Control Box, mounted on the right-front of the vehicle (Figure 8). Remote control of the solenoids occurs through switching in the Master Control Box on the prime mover. The control wiring from the Master Control Box is carried to the SSCV through an umbilical control cable.

FABRICATION

The final design of the prototype system was reviewed in meetings with the NAVEODFAC Project Officer, Marinco project personnel, and at C. L. Haines Manufacturing Company. After a complete review of the design and construction requirements, the fabrication began at the Haines facility in Avoca, New York, on 19 March 1976. The progress of vehicle construction was inspected by Marinco and the NAVEODFAC Project Officer on 29 March 1976. The SSCV was ready for a shakedown test at Avoca, New York, on 25 May 1976.

TESTS AND MODIFICATIONS

PRELIMINARY TESTS

Shakedown Test. The SSCV Prototype was operated for the first time in a field adjacent to the Haines Manufacturing plant facilities. A wheeled farm tractor was used as the prime mover. The remote control subsystem was not installed for this test; the hydraulic functions on the SSCV were controllable by movement of switches on the valve solenoids. An assortment of inert ordnance

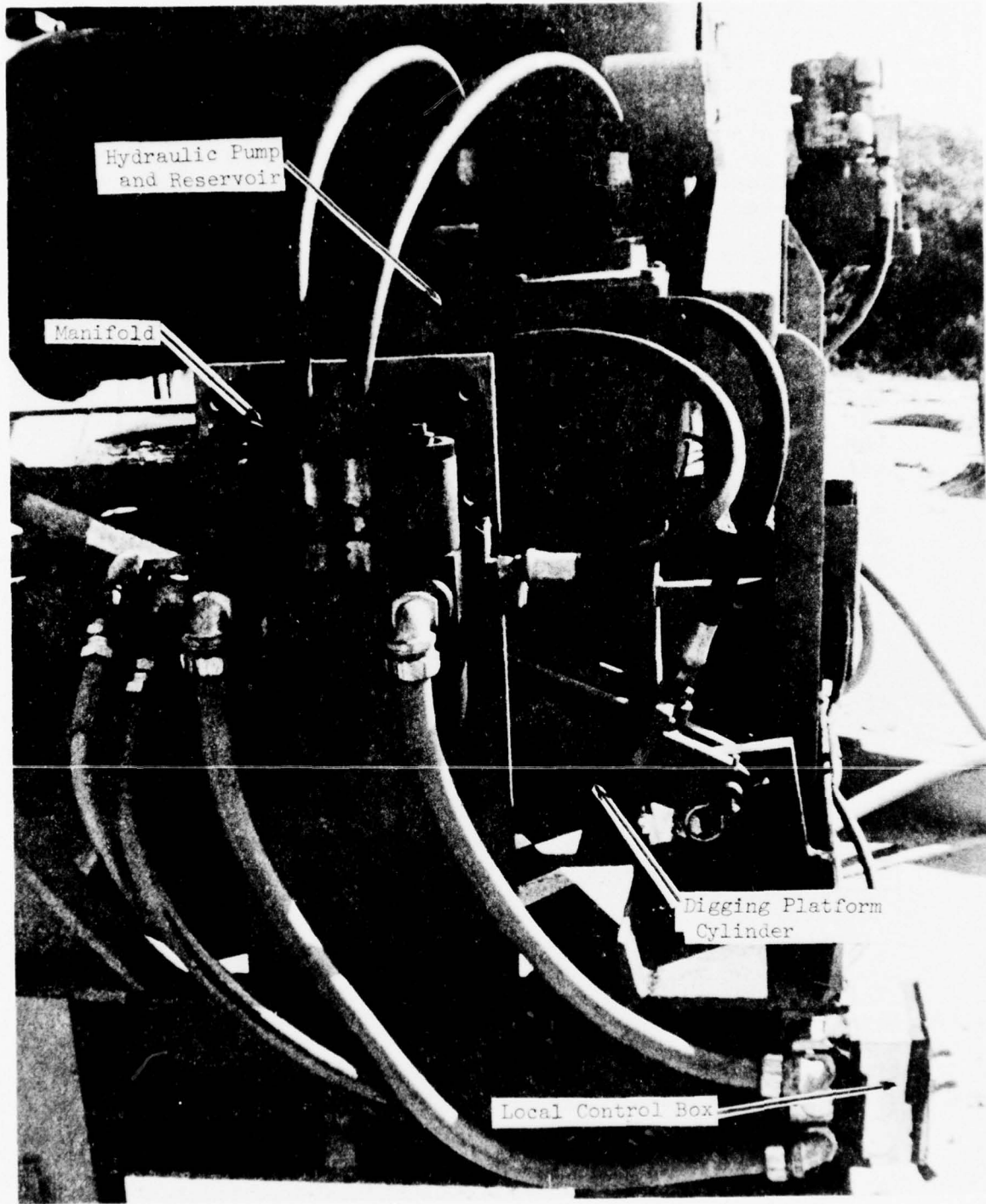

Figure 8. Hydraulic pump, reservoir, and manifold mounted on the SSCV.

was placed on the surface and buried to a depth of 6 inches. The SSCV had no difficulty digging and collecting the ordnance. The sifting of soil from the main conveyor to the fines conveyor belts was hindered by the fact that rain had fallen for at least a week prior to the shakedown and the clayey earth formed into clods that adhered to the Draper chain. The following minor deficiencies were noted in the operation of the vehicle:

1. The SSCV tended to dig more deeply on one side and, therefore, the conveyed material was then loaded into one side of the hopper. The resulting unbalance aggravated the tilt of the digging blade. Experimentation with the digging platform support chains showed that this condition could be compensated for by shortening the chain on the side that was cutting too deeply into the soil. Observation of this difficulty precipitated the discussion for a need to incorporate a self-leveling capability in subsequent SSCV design.
2. It was noted that the fines conveyor belts would throw soil in a trajectory over the soil conveyor belt so that a considerable amount of soil missed the soil belt. This was corrected by adding a steel plate across the rear edge of the soil conveyor which acted as a vertical baffle, deflecting soil onto the conveyor belt.
3. The spring-loaded hitch that was to be mounted on the SSCV towbar had not yet been received from the manufacturer and would have to be evaluated in a later test.
4. The SSCV engine, gasoline tank, hydraulic pump, and other components integral to control of the vehicle appeared particularly vulnerable to even a small detonation that may occur at the digging blade. It was decided that armor plate should be mounted below and behind the engine to protect it and other vulnerable components on the front of the SSCV.

The vehicle was prepared for shipment to Florida, where the first field tests were scheduled for conduction on the ordnance impact range. The pneumatic pump and reservoir were mounted on the SSCV and the local control box was fastened to the front of the frame, allowing local control of the SSCV hydraulic functions.

INITIAL FIELD TEST

Final Preparation for the Test. The SSCV was transported by truck from Avoca, New York, to NAS Cecil Field, Florida, arriving there on 9 July 1976. Maringo personnel arrived at Cecil Field on 10 July and worked with the EOD Detachment in mounting the remote

control (Master Control) box on the prime mover (TD-20, International Harvester, Bulldozer). The control wiring on the SSCV was completed at Cecil Field and the actuation of the steering and travel mechanisms on the TD-20 was tested before departure for PEWR the evening of 11 July. On Monday, 12 July, the vehicles were off-loaded at Pinecastle Target. Several additional adjustments and modifications to the SSCV towbar were made. The vehicles were placed in tandem and a trial run, by remote control, was made on a road which encircled the assembly area. The clearance tests began on Tuesday and continued through Thursday, 13 through 15 July.

Description of the Test. The Pinecastle Target complex is shown in Figure 9. The SSCV was tested on the access road between Tower No. 2 and the Main Bull and between the Main Bull and the Live Ordnance Impact Area.

Monday, 12 July

The TD-20 and SSCV were off-loaded at the "clay pit" area southwest of Tower No. 2 on the Pinecastle Range (see Figure 9). When the engine on the SSCV was started and the digger blade was raised, it was noticed that the weld was broken on the main frame support for the digger blade hydraulic cylinder. This was re-welded and additional support braces were added. (See Figure 10.) Because the spring-loaded hitch (quick-release) was not delivered in time for the Pinecastle tests, a shearpin drawbar was improvised by using a locally purchased 5/8-inch threaded rod, as shown in Figure 11. The hitch on the SSCV towbar had to be further modified by cutting off part of the vertical member after it was seen that more freedom was needed for pitch and roll.

The pin could shear during operation and the vehicles would separate, so it was necessary to devise breakaway connections on the pneumatic hose and power cable between the vehicles. This was done by cutting the hose and inserting a piece of copper tubing as a pull-away splice. The power cable was suspended in a rope harness on the TD-20 so that a direct pull from the SSCV would result in a right-angled pull at the Master Control Box, thus pulling the power plug from the box and freeing the cable (Figure 12).

The SSCV was hitched to the TD-20 and a trial run was made on the road encircling the clay pit area. On this first run, and on all subsequent operations where the SSCV was towed by the TD-20, remote control was used exclusively. The movement on the road around the clay pit showed that some small adjustments were needed on the microswitch positions in the Master Control Box (Figure 13) and that the "clutch" turns to the right and left were more jerky than desired.

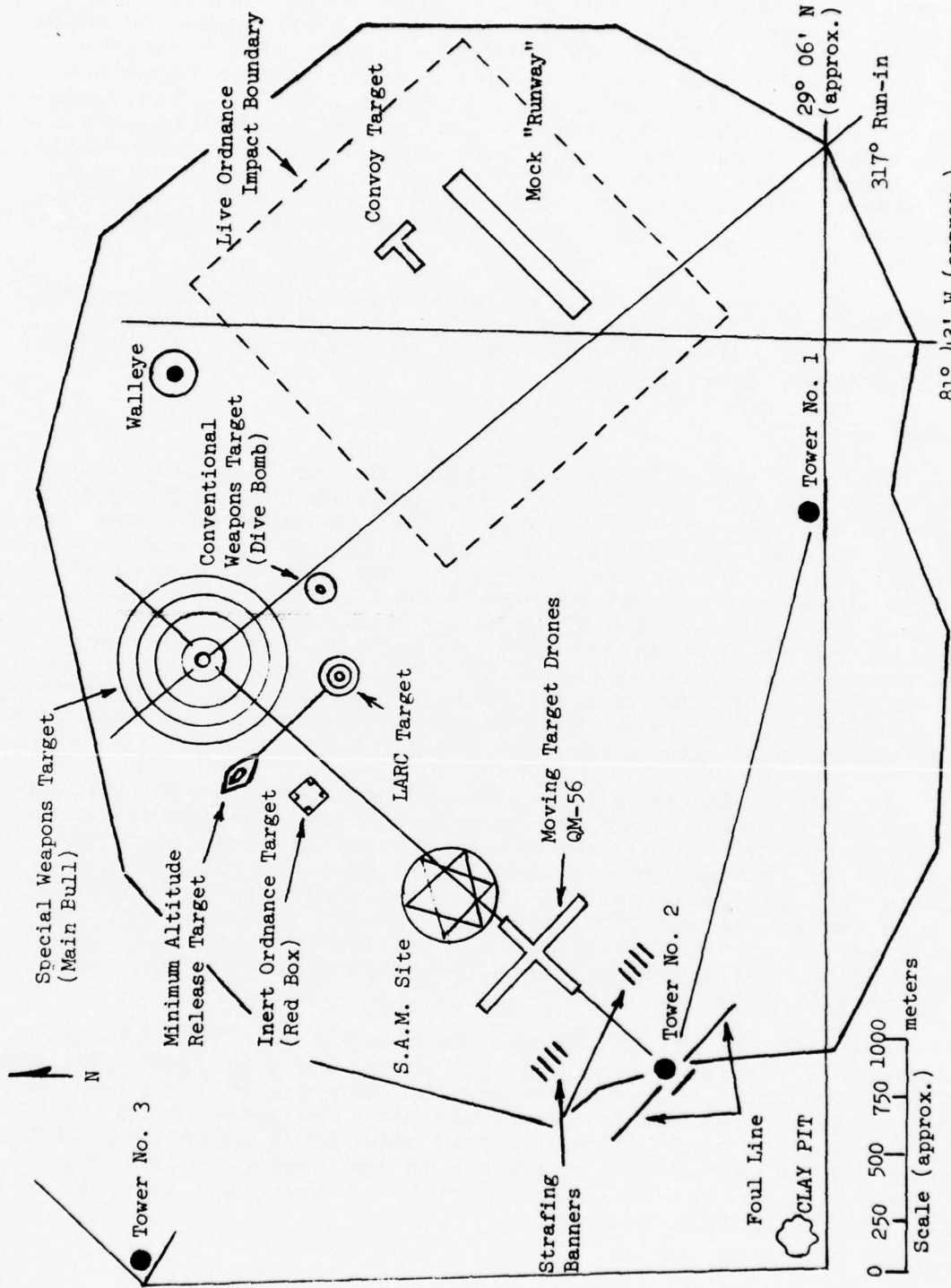

Figure 9. Finecastle target complex.

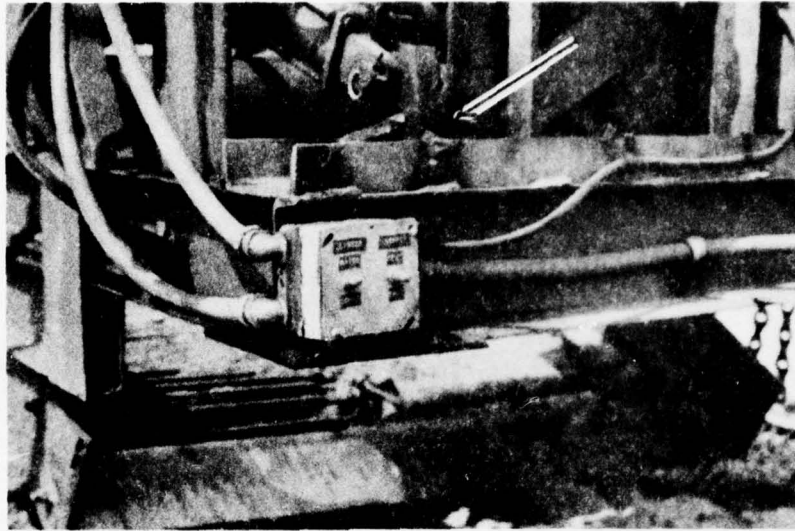

Figure 10. Repaired support for hydraulic cylinder.

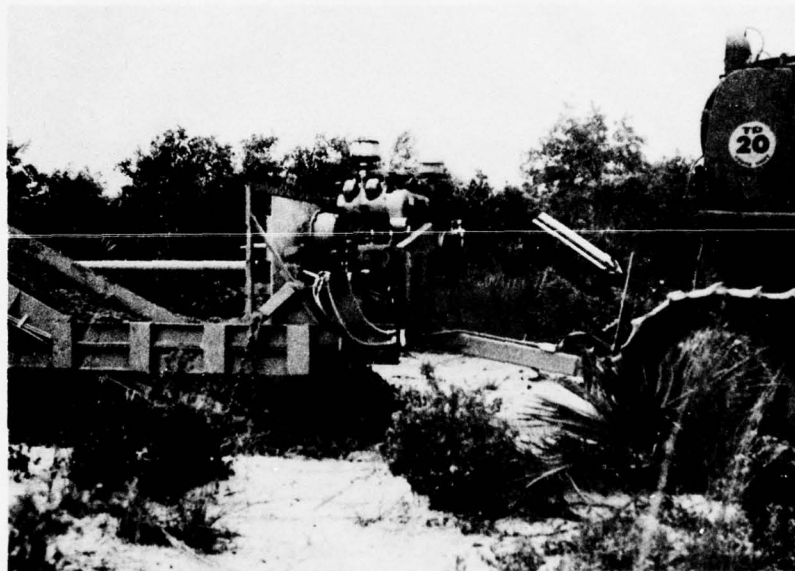

Figure 11. Threaded rod used as shear pin on SSCV hitch.

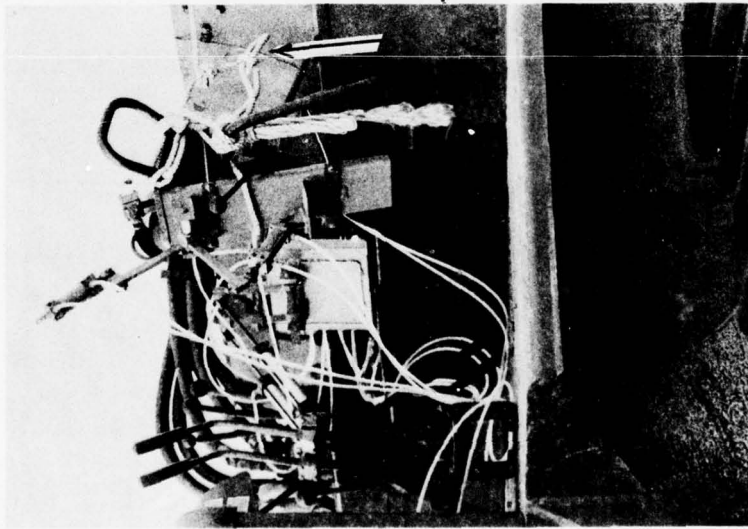

Figure 12. Rope Harness used to facilitate quick-release of control cable.

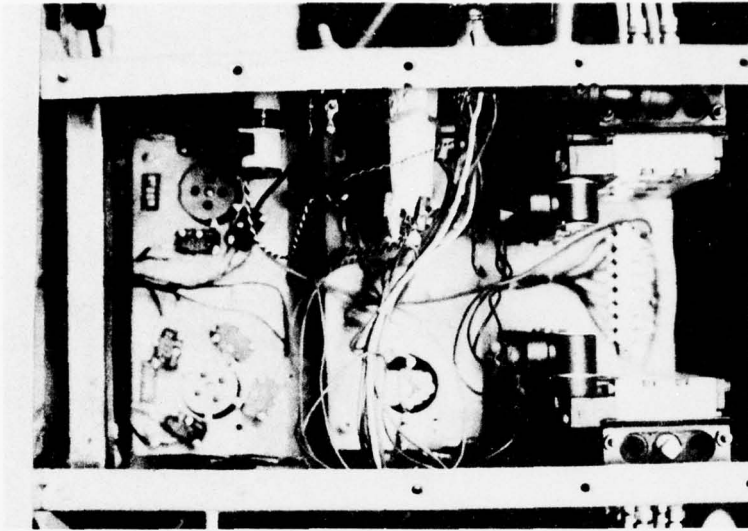

Figure 13. Microswitches mounted on cams in the Master Control Box.

The microswitches controlling the decelerate pedal and the 2nd gear shift lever had to be moved closer together on the periphery of the "travel" cam. The jerky action in the steering control was eliminated by interchanging the clutch and brake pneumatic cylinder actions for each tread. This change was simply accomplished by switching the control wires on the respective microswitches in the control box.

Tuesday, 13 July

The first clearance run was to be made from Tower No 2, along the left side of the road, toward the Main Bull. It rained very hard for about 30 minutes and the digging began in wet sand. It was learned quickly that the digging blade on the SSCV was set too low when the vehicle nosedived to a depth of over 2 feet. The TD-20 was backed up, pushing the SSCV out of the hole, and the sand was shoveled clear.

The digger blade chains were reset for a shallower cut and movement was continued down the road toward the Main Bull. The depth of cut was 8 to 10 inches and the SSCV was operating quite well. Since the vehicle was still close to the tower, very little debris was being deposited in the hopper. Soon afterward, metal fragments and 50 cal. rounds were moving up the main conveyor and into the hopper. As the SAM site, which straddles the road, was approached, MK 106 and MK 76/BDU-33 practice bombs began to go into the hopper. Some of these were from the surface and some were 6 to 8 inches below the surface.

The TD-20 was steered to the middle of the road after moving about 1000 meters from Tower No. 2. It was here that the SSCV digging blade hit a folded snakeeye fin assembly, buried vertically below the surface. The blade rode up over the fins and, as the underslung portion of the Draper chain was drawn over the fins, about 10 sections (bars) in the Draper chain were bent. The system was shut down and two "come-alongs" were rigged to loosen the Draper chain. The bent sections were removed and straightened with light sledge hammers and by using points of leverage on the SSCV drawbar. The chain was reassembled quickly.

The system was moved over to the right side of the road and digging was continued. About 1800 meters from the starting point (Tower No. 2) the digging blade on the SSCV began to raise and lower in an uncontrollable cycle and, at the same time, the TD-20 turned to the right with the lever held in the clutch position. A brief attempt was made to bring the bulldozer under control remotely before the operator climbed aboard and manually shut down the system. The remote-control receiver battery was checked and found to be very low. The battery was removed for overnight recharging.

Wednesday, 14 July

Operation was continued along the right side of the road and onto the Main Bull (Figure 9), which has extensive surface contamination.

The system was moved around the southeast quadrant of the Main Bull, turned left through 360° and onto the road that marks the run-in line. This road contains a large number of MK 76 and MK 106 practice bombs and a variety of scrap metal. As seen in Figure 14, the ground cover on each side of the road is palmetto, grass and brush, and pine trees.

Moving from the Main Bull to the Live Impact Area, the center of the run-in line was cleared to a depth of 6 to 8 inches. The rough contour made it difficult to determine actual digging depths. At the boundary of the Live Impact Area, the system was turned 180° by moving off the right side of the road and then steering to the left as tightly as possible. The improvised hitch on the SSCV restricted the turn radius during this maneuver.

After completing the turn, the system resumed clearance operations off the right side of the road and in the brush area. The long roots became a nuisance in this region. They never stalled the operation of the SSCV, but clumps of soil and sand were carried into the hopper with the brush and roots. A MK 81 (250-lb.) bomb was picked up by the SSCV along this route and loaded into the hopper (Figure 15) without difficulty.

The cratered condition of the bank along the road caused too much pitch for the improvised hitch and the threaded rod sheared for the first time. The method devised for protecting the umbilicals worked properly and the TD-20 was stopped before any damage was done. The threaded rod was long enough that it could be used again and operation was continued. After moving another 50 meters, the rod broke again and it was decided to use a different hitch configuration. A pintle ring was removed from a scrapped (target) vehicle on the range and the ring was welded to the SSCV towbar. Two of the four bolts were removed from the hitch mount to provide a safety breakaway on the drawbar. This new arrangement not only withstood the rigors of the rest of the tests, but also gave better pitch and roll and allowed for a smaller turning radius.

As operation continued toward the Main Bull, the conveyor drive on the SSCV suddenly stopped, stalling the Wisconsin engine. Examination of the Draper chain revealed that one of the rods had slipped under the leading edge of the soil pan. As shown in Figure 16, a prybar was used to free the bar and the rolled edge of the soil pan was bent back to its proper position.



Figure 14. Ground cover along the run-in line between the Main Bull and Live Ordnance Impact Area.

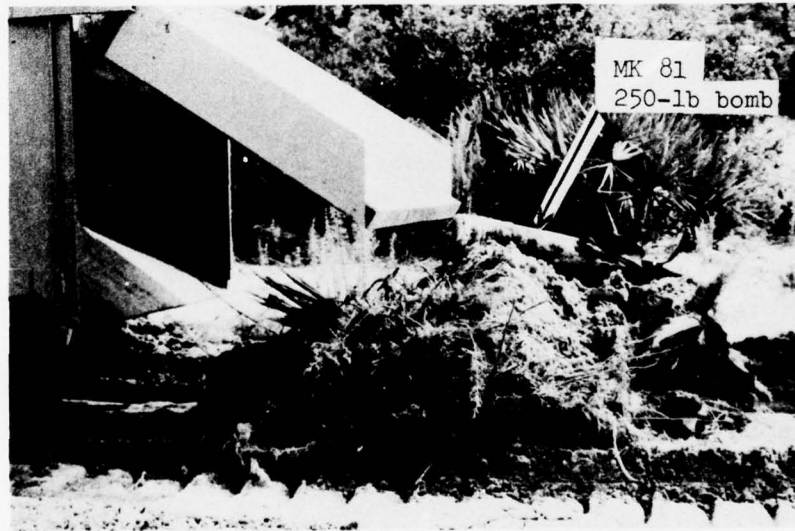

Figure 15. Debris and ordnance dumped from the SSCV hopper.



Figure 16. Prybar used to release jam in the Draper chain.



Figure 17. Clearance of the run-in line road between the Main Bull and the Live Ordnance Impact Area.

Thursday, 15 July

Before resuming clearance of the run-in line road, the area was back-bladed with the TD-20 to give a fresh, level test-bed for the day's operations. SSCV clearance of this area is shown in Figure 17.

The system was again operated over the approximately 600 meters between the Main Bull and the Live Impact Area. After turning to go back to the Main Bull, the system was moved along the left bank of the road, through moderate ground cover and over a cratered surface. Several times, when the TD-20 moved into a crater, the SSCV would dig too deeply and the sand and debris would fill the throat of the vehicle. When this happened, the TD-20 was stopped and the conveyors were allowed to run so as to clear the load from the SSCV. It was while this was being done that the fines conveyor belt on the right-hand side separated at the stapled seam and became entangled in the Draper chain rods. The system was shut down, the Draper chain removed, and the fines belt was extracted from the vehicle. It was observed that the staples had all opened at the seam but had not torn through the belt edge; no damage to the fines belt was incurred. It was decided to continue the digging operation without a fines belt on the right side.

About 100 meters from the Main Bull, the conveyors again stalled and 10 to 12 sections of Draper chain on the left-hand side were pulled into horseshoes (Figures 18 and 19). After clearing sand from the digging platform, two MK 106 practice bombs were found to be jammed between the Draper chain and the soil pan; one of these practice bombs was caught at the front axle of the Draper chain. These bombs had apparently fallen onto the slack portion of the chain under the vehicle, perhaps after rolling from the edge of the cleared swath, and the chain had tried to move them over the front axle, trapping them between the chain and the digging bed. The system was shut down for the day.

The SSCV was towed to Tower No. 2. The bent Draper sections were removed, the chain and pulley guards were dismantled, and the rear armor was unbolted. The clutch mechanism had failed to operate properly during the last part of the tests so the clutch assembly cover was removed from the engine. It was discovered that the clutch plate had shattered inside its housing. The slip clutch on the main conveyor drive had also failed to prevent the damage incurred in the latter phase of the tests. It was found that this clutch plate would not adjust properly.

No further tests were made, pending the arrival of spare parts. It was estimated that, with the parts on hand, the system could be operational within 2 or 3 hours.

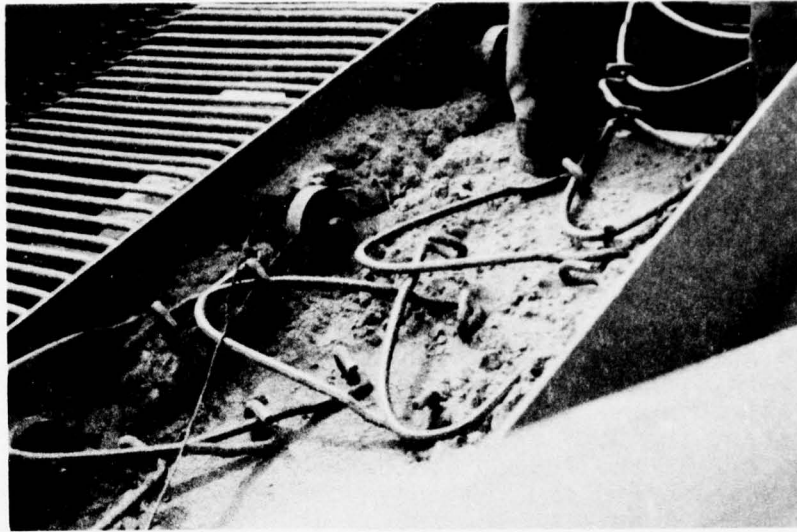

Figure 18. Draper Chain sections bent by severe jam in the main conveyor.

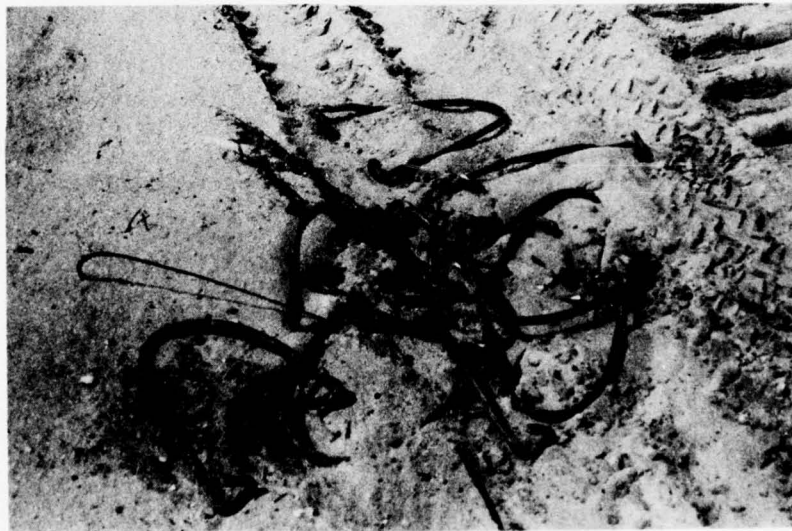

Figure 19. Bent Draper sections removed from the main conveyor.

Summary of Test Results. It was adequately demonstrated that the maneuvering of the TD-20 and the essential functions of the SSCV can be controlled by radio remote control on an ordnance impact range. It was learned that more latitude of movement on the remote operator's control levers would be desirable; the TD-20 travel and steering commands were sensitive to the slightest change in joystick position. Additional fail-safe features would be necessary to prevent loss of control; such as: a low-pressure switch that would stop forward movement of the prime mover should air pressure to the controls be lost; a low-voltage switch which would stop the vehicle when a problem develops in the electrical power source. Smoother control of the prime mover could be achieved by installing pressure release valves on each pneumatic cylinder. The reliability of the remote-control receiver power supply could be improved if the receiver were powered directly from the on-board 12-volt storage battery rather than the small, rechargeable power pack.

The maximum single-pass cut made during these tests was 10 inches. More often, the depth was between 6 and 8 inches. There was nothing to indicate that iterative passes through the previously-cleared areas would have presented any difficulty. A minor deficiency was noted in clearing the small practice bombs that were on or near the surface: when these bombs were near the outboard edges of the digging blade, they tended to be swept aside rather than onto the conveyor mechanism--much like a bow wake. A problem in SSCV design that could be more serious is that the slack portion of the Draper chain that is very close to the ground is vulnerable to damage from buried objects; also, ordnance and other debris can roll onto this open section of the Draper chain and become entrapped at the front axle of the chain or on the soil pan. The smallest ordnance types observed in the hopper were 50-caliber rounds; the largest was a 250-lb. LDGP bomb body.

The separation and windrow capabilities were adequate in most of the tests. The only time that difficulty was encountered was in the areas where brush was growing and the long roots would drag clumps of earth into the hopper. There were times, usually in rough terrain, when the SSCV would take on sand or soil at a greater rate than it could be processed by the Draper chain and fines conveyors. It was found that the forward travel had to be stopped and the conveyors given time to dispense of the material piled at the throat of the SSCV.

The main conveyor (Draper chain) is of sufficient strength and is driven with adequate power to transport excavated material, including 250-lb. bombs. The weaknesses are in the exposure of the chain to heavy, buried objects not picked up by the digging blade and in the susceptibility to jamming at the front axle or digging pan. The inability to adjust the slip clutch on the main conveyor drive contributed to the damage to Draper chain sections during the tests.

The solid belt conveyors are sturdy enough to handle the sifted material; the seam stitching must be stronger to withstand occasional heavy soil/sand loads.

No maneuverability or stability problems were encountered. The turning radius was significantly improved when a pintle ring was mounted on the SSCV. Even in the soft sand and with a full hopper load, the SSCV shows good roll stability. No provision was made for remote-control reverse operation of the TD-20; when the system had to be backed up, this was done by manual override on the prime mover. In the pitch mode, the SSCV is forced into making a deeper cut than is desired.

Several modifications to the existing prototype system will enhance its capability and increase its adaptability to variable working conditions. These modifications and improvements are discussed below.

1. Remote Control
 - o Provide vertical whip antenna with cable disconnect at receiver.
 - o Operate receiver from on-board 12-volt battery.
 - o Add reverse travel to prime mover control.
 - o Provide quick-disconnect umbilical connectors for pneumatic and power cables between vehicles.
 - o Remount microswitches and cams to provide less-critical operator control.
 - o Provide fail-safe switches to stop prime mover when there is failure in the hydraulic, pneumatic, electrical, or mechanical systems.
2. SSCV Conveyors
 - o Reduce amount of slack in the Draper chain that is under the SSCV by mounting additional carry-back rollers.
 - o Simplify disassembly of Draper chain.
 - o Provide Draper chain rod-straightener on board the SSCV.
 - o Restitch solid belt conveyors with heavy-duty fasteners.
 - o Spring-load front axle of Draper chain to alleviate jamming.
3. Additions to the SSCV Main Frame
 - o Mount spring-loaded hitch (this was called for in the initial design but was not received from the supplier before the tests).
 - o Mount shock absorber arms on the digger bed to prevent Draper rod damage on rock outcroppings, rigidly buried objects, etc.

- o Provide root-cutter capability in front of digging blade which can also serve to deflect debris toward the digging blade.
- o Mount spare wheel on the rear of the hopper door.
- o Mount flexible skirts on right and left sides of the main frame to prevent items from rolling onto the slack portion of the Draper chain.

PHASE I MODIFICATIONS AND FOLLOW-ON TESTS

Preparation for Tests. Project personnel arrived at PEWR on 16 August 1976 to resume the test program. The SSCV was parked at the shop facilities at PEWR so that welding, cutting, and machine work could be done before deployment to the impact range. The spare parts and material necessary for accomplishment of repair and Phase I modifications on the SSCV Prototype System were shipped to PEWR by Marinco. The Marinco project personnel and the EOD Detachment worked 3 days to prepare the system for operation on the range.

Monday, 16 August

The first modification made to the SSCV was on the leading edge of the soil pan. To eliminate rod jams, the rolled edges were cut from the right and left halves of the soil pan and a three-inch, heavy-walled steel pipe was fitted into the space athwart the digging bed assembly. The soil pan was welded to the pipe to give a smooth leading edge surface. Since the Draper chain had to be removed to work on the soil pan, sections (rods) that had been bent during the July tests were straightened or, where necessary, replaced with new sections. The new throwout bearing was installed in the Wisconsin engine clutch housing and the engine was run to test the declutching operation.

Tuesday, 17 August

Using heavy-duty staples, the Pylon belt on the right fines conveyor was restitched. This resulted in the belt being several inches shorter than it was originally, partly because of the restitching and partly because the belt could not be stretched to the extent that it had been when previously installed. The fines belt on the left side was also removed and restitched with heavy-duty staples. To reinstall both these belts, the bottom rollers had to be moved several inches and then adjusted for proper belt tension after installation.

The slip clutch on the Draper chain drive (Figure 20) required considerable persuasive effort before it would function properly. The outer clutch plate was "frozen" in place because of rust. A special bracket was fabricated to pull the clutch plate loose.

A plywood baseplate was used to mount the Master Control Box on the seat of the TD-20. Because this was not the same bulldozer

used in July, slightly different lever-travel distances were required for clutch and brake operations and adjustments had to be made in the stroke distances of the air cylinders on the Master Control Box. Generally, the installation of the control box and linkages to the bulldozer operating levers was accomplished without difficulty.

Before the Draper chain was reassembled, 10 sections were removed from each chain. This reduced the sag beneath the vehicle. The Draper chain, in this shortened length, hung just clear of the fines belt adjustment brackets when the digging blade was in the maximum raised position.

All the lube points on the SSCV (and engine) were greased and the belt operations were checked in a final preparation for the test run on the range.

Wednesday, 18 August

The Pinecastle target authorities opened the range for SSCV tests from 1100 hours to sundown. After deployment to the range, the digging operation began on the road between Tower No. 2 and the Main Bull (see Figure 9). The tests were frequently interrupted by heavy rainfall and air-to-ground rocket firings on the live impact range.

Representatives from NAVEODFAC were conducting tests with a Varian magnetometer on the moving target area and the SSCV was moved onto this area to assist in the tests by clearing surface contamination.

As the allotted time on the range was running out, the SSCV system was moved back to Tower No. 2 to await the next day's tests.

Thursday, 19 August

The SSCV was towed from Tower No. 2 to the Main Bull, where extensive surface and subsurface contamination exists. Most of the contamination in this target area is from MK 76 and MK 106 practice bombs. The NAVEODFAC personnel who were testing the Varian magnetometer preceded the SSCV at the Main Bull and spray-painted grids where they wanted the vehicle to remove contamination to a 15- to 20-centimeter depth. After accomplishing this, the SSCV was operated in a counterclockwise circle, just outside the ring of the target.

During this operation, frequent jams occurred between the digging blade and the Draper chain as it moved over the cone rollers. In some instances, the MK 106 practice bomb fins would become lodged between the Draper sections as the vehicle passed over the bombs; sometimes the bombs would become jammed, as shown in Figure 21, just as the digging blade passed over them and they

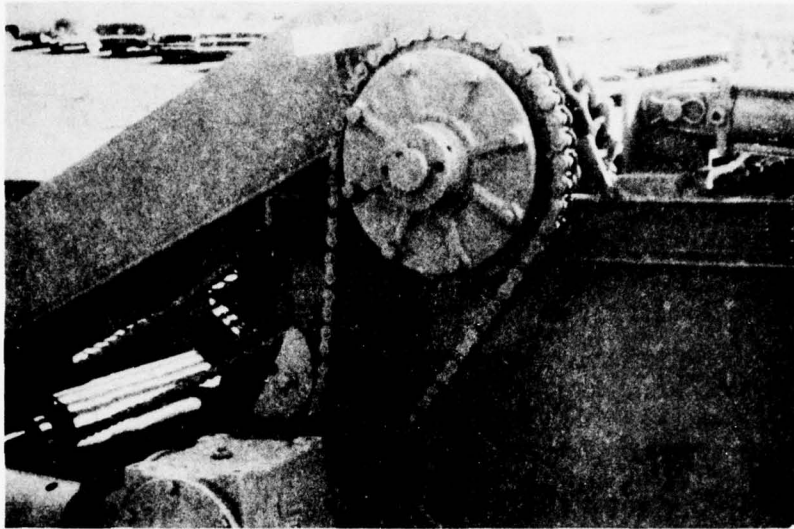

Figure 20. Slip Clutch on main conveyor drive.

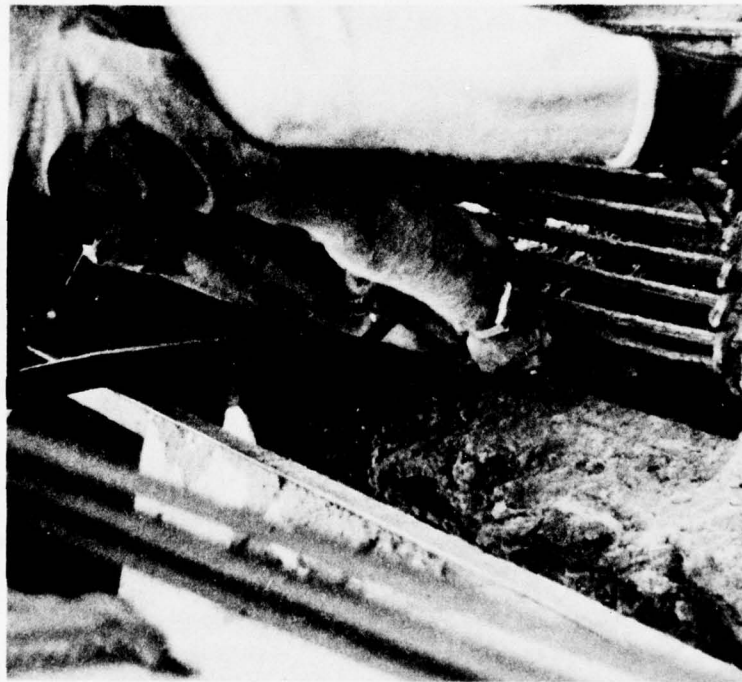

Figure 21. Practice bomb jammed in front of main conveyor.

would be pushed into the leading edge of the Draper chain at the cone rollers. These jams had to be removed with a pry bar.

Two failures occurred in the belt conveyors in the late afternoon. First, the staples parted on the right fines conveyor; this was the belt that had been restitched at the beginning of the week. Second, the soil conveyor belt began to drift to one side of the drive roller and rode up onto the frame of the conveyor assembly. The extremely difficult access to the roller tension adjustments on the soil conveyor made the task of correcting the belt eccentricity an extremely frustrating one. When the soil belt was removed, it was discovered that the drive roller had fractured longitudinally and the spot-welded end cap had separated from the drive roller. (See Figure 22.)

With only a half-hour of daylight remaining, one more turn was made along the periphery of the Main Bull. It was in this twilight that the SSCV unexpectedly dug up a MK 82 (500-lb.) bomb and deposited it on the Draper chain. The bomb rode up and slid back down the main conveyor incline three times before it was dumped into the hopper, as shown in Figure 23. As darkness approached, the SSCV was towed to the Pinecastle shop facility for repair and further modification.

Friday, 20 August

This day was spent performing modifications on the SSCV. The Pylon belts and broken conveyor belt roller were taken to Jacksonville for repair.

To prevent the jams caused by practice bombs, the front end of the digger platform was rebuilt. After removing the Draper chains and the front cone rollers, the soil pan was cut back 4 inches and the pipe sections were remounted and welded to the leading edges of the pan. The cone rollers were also remounted 4 inches further back from the digging blade. This modification is shown in Figure 24.

To end the frustration of adjusting tension on the soil conveyor roller, the bracket was modified so that the adjustment was reversed, extending the bolts and nuts outboard of the vehicle main frame. Cheek plates were cut from flat stock and welded onto the front of the digging bed.

Saturday, 21 August

The fines conveyor belts were remounted with less tension than they had been when the SSCV was delivered from Haines Manufacturing. The Draper chain was reassembled with considerable ease, using Draper tools (load-binders) made specifically for use on the SSCV.

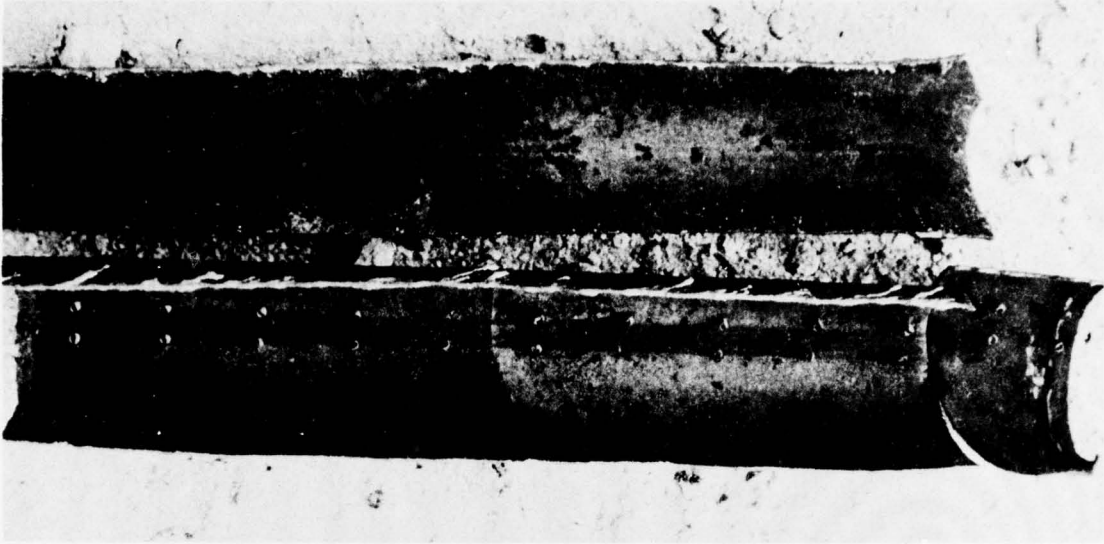

Figure 22. Fractured drive roller from SSCV soil conveyor.

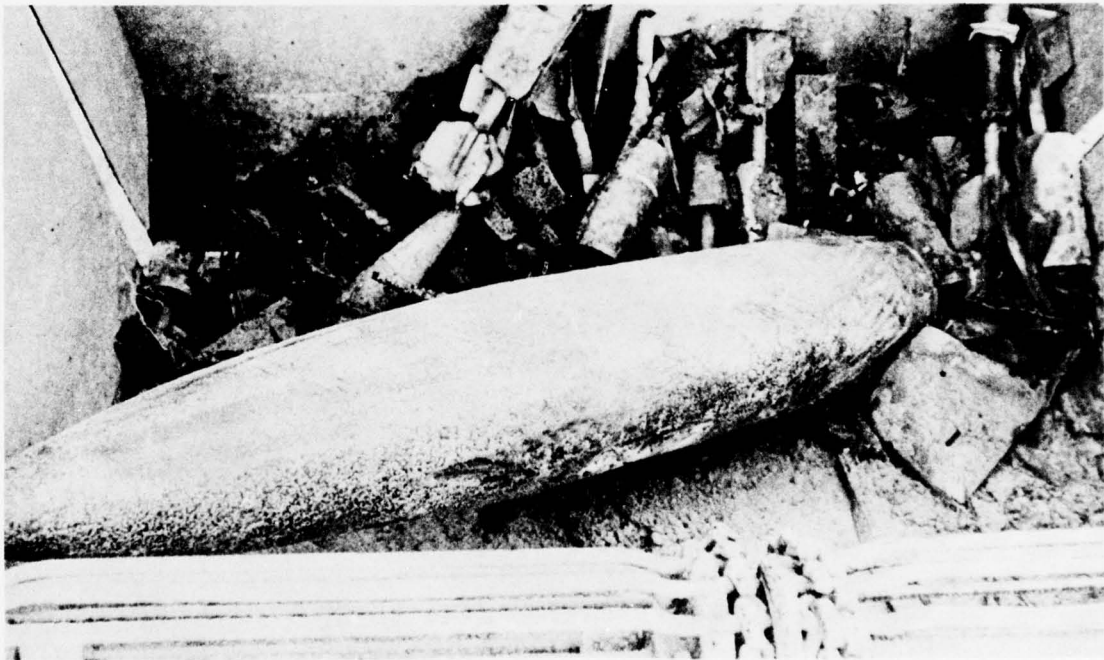

Figure 23. MK 82 (500-lb) bomb dug up and loaded into SSCV hopper.

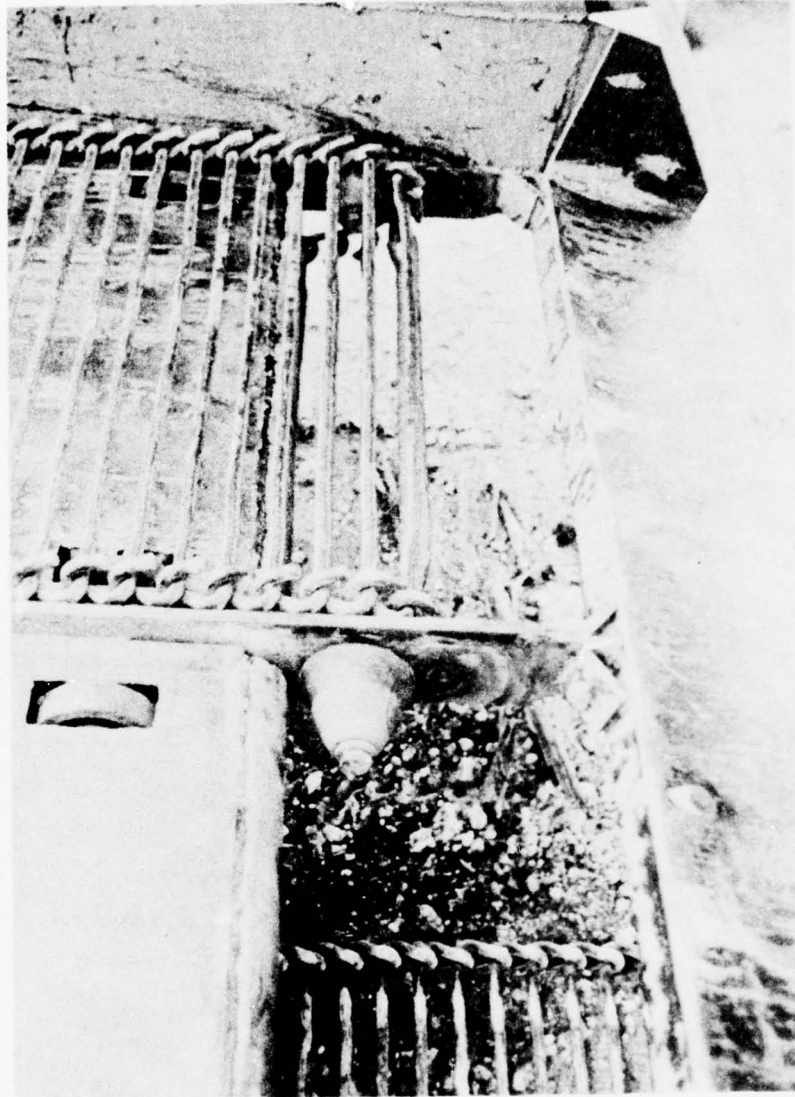

Figure 24. Modification made to SSCV digging platform to eliminate jams caused by practice bombs.

The toolbox was welded onto brackets on the right side of the hopper and the spare wheel was mounted on the back of the hopper.

The SSCV system was towed to the Main Bull and excavation commenced on the run-in line between the target and the live impact area. The front-end modifications were successful in that no jams occurred between the Draper chain and the digging blade. The cheek plates diverted the material onto the blade, as was anticipated. These plates increased the volume of material passed through the throat of the SSCV at a particular digging depth but the vehicle had no difficulty handling and processing the load.

The gap between the Draper chain at the front cone rollers and the digging blade did allow sand and small objects (including some practice bombs) to fall back onto the ground rather than being pushed onto the soil pan and conveyor. This was corrected with the installation of Pylon flaps that allow jammed objects up through the gap, but prevent material from falling back through to the ground.

Summary of Phase I Modifications and Test Results. The modifications resulted in improvement of the overall system operation. Many of the recurrent problems encountered during the earlier tests in July were solved and the follow-on tests confirmed the necessity to complete the Phase II modifications on the vehicle.

The slip clutch on the conveyor drive, once it was adjusted properly, performed as it should and no severe damage to the Draper chain sections occurred after that. After it was realized that the Pylon belts on the fines and soil conveyors had been installed with too much tension when the SSCV was originally assembled, the conveyor takeup blocks were adjusted and no more problems occurred with the belts.

Installation of cheek plates on the sides of the digging blade accomplished two major improvements. First, the lighter items that were being pushed in front of the digging blade were directed into the throat and onto the main conveyor instead of drifting off to the side of the vehicle. Second, the items that were on the outer corners of the digging swath were diverted far enough to either side of the vehicle line-of-travel that they did not tend to fall back under the vehicle and cause jams in the Draper chain.

The modification performed on the gap between the digger blade and the front cone rollers on the Draper chain was probably the most significant improvement in system reliability. The occurrence of jams in the front of the Draper chain was the most frequent cause of problems in the July tests and in the beginning of the follow-on tests in August. The action taken to widen the gap in back of the digging blade, by moving the cone rollers back 4 inches, eliminated these jams for the rest of the test period.

A number of minor modifications and adjustments were made that also added to the success of the follow-on tests. For example:

- The mounting of the Master Control Box on the prime mover was simplified.
- Heavier staples were used to restitch the seams of the Pylon belts.
- Slack was taken out of the main conveyor by removing sections of the Draper chain.
- An access port was cut in the chain guard that covers the slip clutch plate so that the clutch can be easily adjusted in the field.
- The adjustment assemblies on the end rollers of the fines and soil conveyor belts were remounted so they were accessible for adjustment in the field.

Because the SSCV was originally designed to collect and store ordnance items up to the size of a 250-lb. bomb (MK 81), the incident regarding the 500-lb. bomb is of notable interest. If this bomb would have been on the surface and visible, the operator controlling the movement of the SSCV system by remote control may have made the decision to steer around the bomb. However, the bomb was buried at least 6 inches below the surface and there was no indication of its presence until it had been dug up and loaded on the main conveyor of the SSCV. Not being sure at first what had been collected, but knowing it was significant, the vehicle was halted and the test personnel walked to the vehicle to examine the ordnance. The decision was made that, since the bomb was already part way up the main conveyor, the test should be made as to how it would load into the hopper. This was done without any noticeable strain to the SSCV.

PHASE II MODIFICATIONS AND FINAL TESTS

Preparation for Tests. Project personnel arrived on 6 December at PEWR for this final phase of the contract test program. Limited workshop facilities and almost continuous rain required that all modification work be done in the hobby shop garage at the PEWR base facility. The modifications to the SSCV were extensive and required a week for completion.

Tuesday, 7 December

Since the hopper door and the self-leveling mechanisms would require the most extensive work, these tasks were started first. The hopper door was tack-welded in the closed position so that the hydraulic cylinders and opening levers could be removed. Holes were burned through the channel iron to allow hydraulic hoses to be run to the new cylinder positions.

Calculations for the mounting of the self-leveling axle hardware were checked and the axle mountings were cut loose with a torch. The leveling system control box (see Figure 25.) was mounted on the front of the SSCV main frame and electrical connections were made to the level control solenoid on the hydraulic manifold.

The TV system mounting bracket was assembled and placed on the frame of the SSCV. The cameras, transmitter, junction box, and camera-switching relay box were fastened in place. The TV system control wires were run from the mounting brace and down the right side of the vehicle.

Work began on the control wiring within the master control box. A receiver antenna mount was fabricated and mounted on the rear of the master control box.

As the hydraulic hoses were being disconnected from the SSCV to make way for the mounting of a new 4-valve manifold system, several fittings were frozen so tightly that they fractured when turned with a wrench. It was decided to replace the majority of the hydraulic hoses and fittings.

Wednesday, 8 December

The wiring was completed in the master control box and the response of the cams and microswitches was checked through use of the remote control transmitter. After affirming that all functions were correct, the microswitches and air hose connections on the master control box and the operator controls on the transmitter were labeled. It was decided to use one of the spare channels on the remote control to allow the operator a selection of "accelerate" or "decelerate" regardless of the travel mode selection on another channel. A whip antenna for the remote receiver was mounted on the rear of the master control box. The TV system wiring was completed. This system could not be checked because of the welding and metal-cutting work being done on the frame of the SSCV.

The axle tilt assembly was welded into place and the self-leveling cylinder was mounted on the SSCV undercarriage as shown in Figure 26. The hopper door cylinders were moved to the new positions required by the change in hopper door design. Figure 27 shows the remounted cylinder on the left side of the hopper.

Thursday, 9 December

The new master control box was positioned on the TD-20 prime mover and the control actuation cylinders were connected to the bulldozer operator levers. A reserve air tank was used to supply pneumatic pressure to the air system so that the movement of the controls could be adjusted and completely checked. The Seabees had to take the prime mover to the range in the afternoon because the TD-18 had been sent to Rodman Target and a dozer was needed on the range. Live firing was taking place

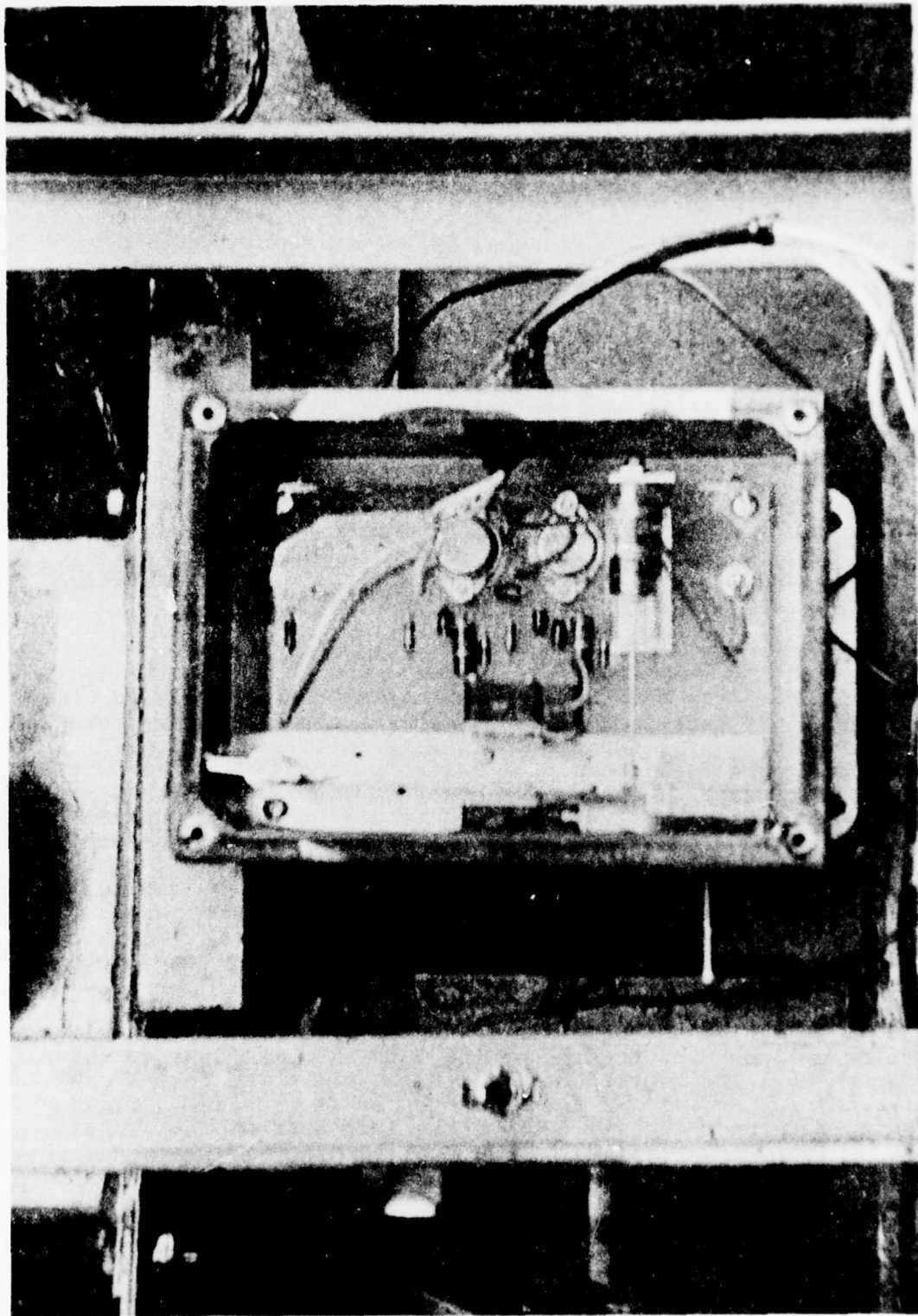

Figure 25. Self-level sensor box mounted on the front of the SSCV frame.

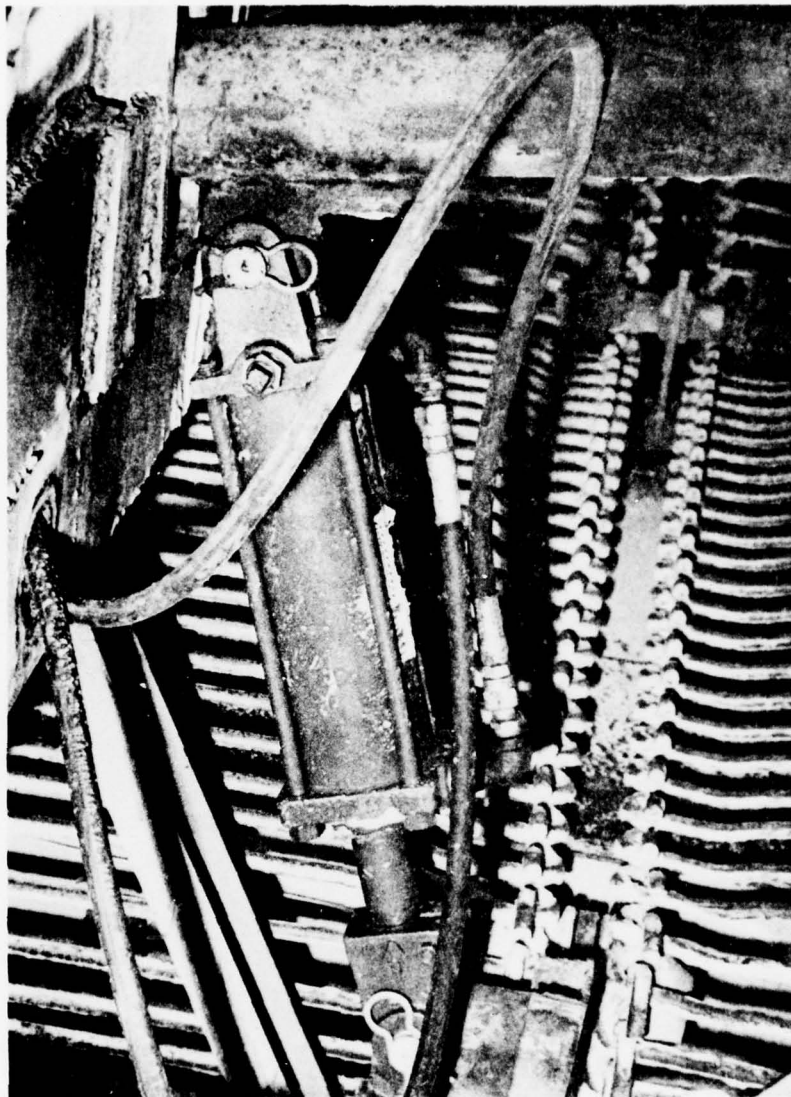

Figure 26. Axle tilting mechanism mounted on SSCV axle; self-level cylinder is fastened to the right side of the axle.

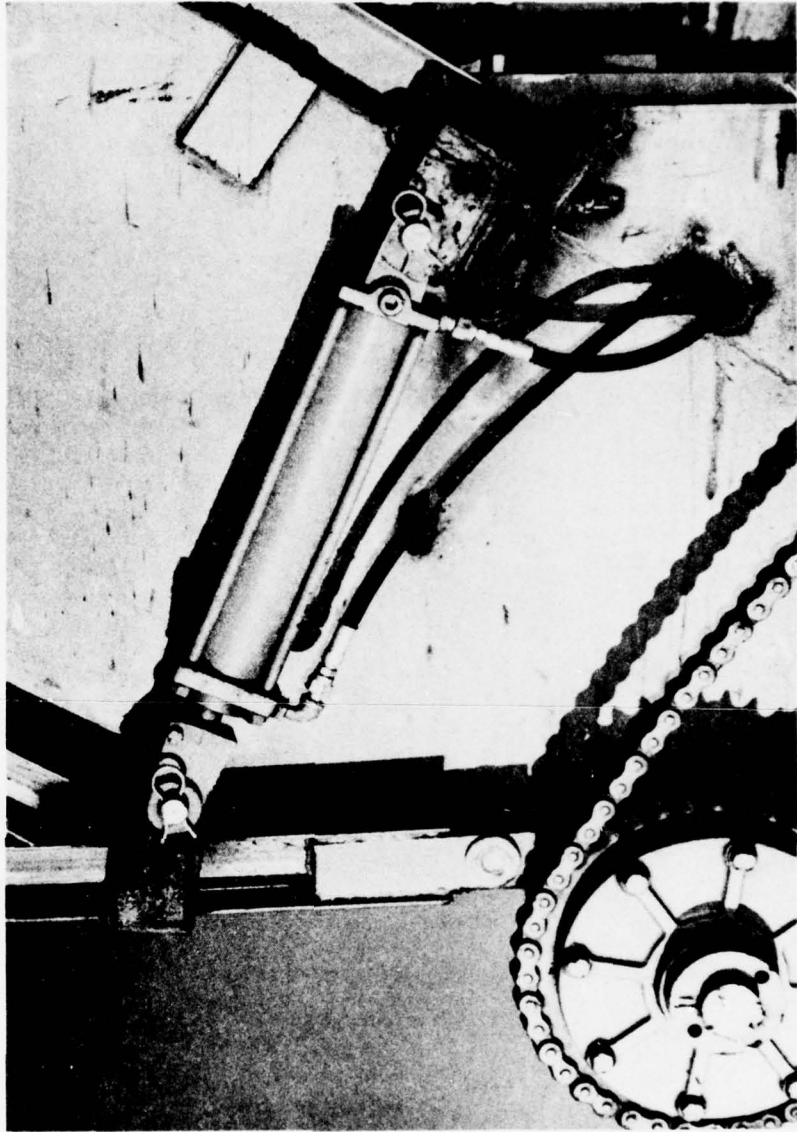

Figure 27. Hydraulic cylinder mounted on the left side of the SSCV hopper.

on the range and the Seabees were required to stand by in the event firebreaks were needed.

The new towbar assembly, shown in Figure 28, was welded onto the SSCV. It was necessary to cut about 2 feet off the rear end of the new towbar so that it could be slipped over the old towbar.

Friday, 10 December

The hydraulic pump was disassembled, inspected, and cleaned and it appeared that it was operating properly. The SSCV engine was started and leaks in the hydraulic system were detected and stopped by tightening several fittings.

The hydraulic manifold was carefully examined and smoke was blown through it as operating ports were alternately covered. This experiment led to the conclusion that the manifold was not the proper one for the system. The manufacturer had shipped a parallel manifold, whereas a series type had been ordered. Using spare fittings and other parts available, a properly configured manifold was assembled.

Saturday, 11 December

The new manifold system, shown in Figure 29, was installed on the SSCV. The system was activated and performed properly. Because there were not enough manifold parts to assemble a four-solenoid system, the hydraulic jack had to be left out of the control capability. The other three hydraulic functions (Hopper Door, Digging Bed, and Self-level Device) functioned as designed.

The TV system was energized and tested. The Honda generator being used to supply 117 VAC to the cameras was fastened to a plate which was welded to the armor support frame. Since the TV system was being tested within the shelter of the hobby shop garage, it was difficult to obtain a good picture on the TV monitor; further testing was postponed until the vehicle could be moved outside.

Measurements were made on the SSCV and it was determined that the increased height of the vehicle because of the axle modification and, more significantly, the elongated towbar assembly increased the angle of attack that would be assumed by the digging bed. Taking into account the fact that the test runs would probably be limited to 6-inch digging depths because of the saturated sand on the range and that the digging and loading capability of the vehicle had been fully demonstrated in previous tests, this was not viewed as a serious impediment to the planned test runs.

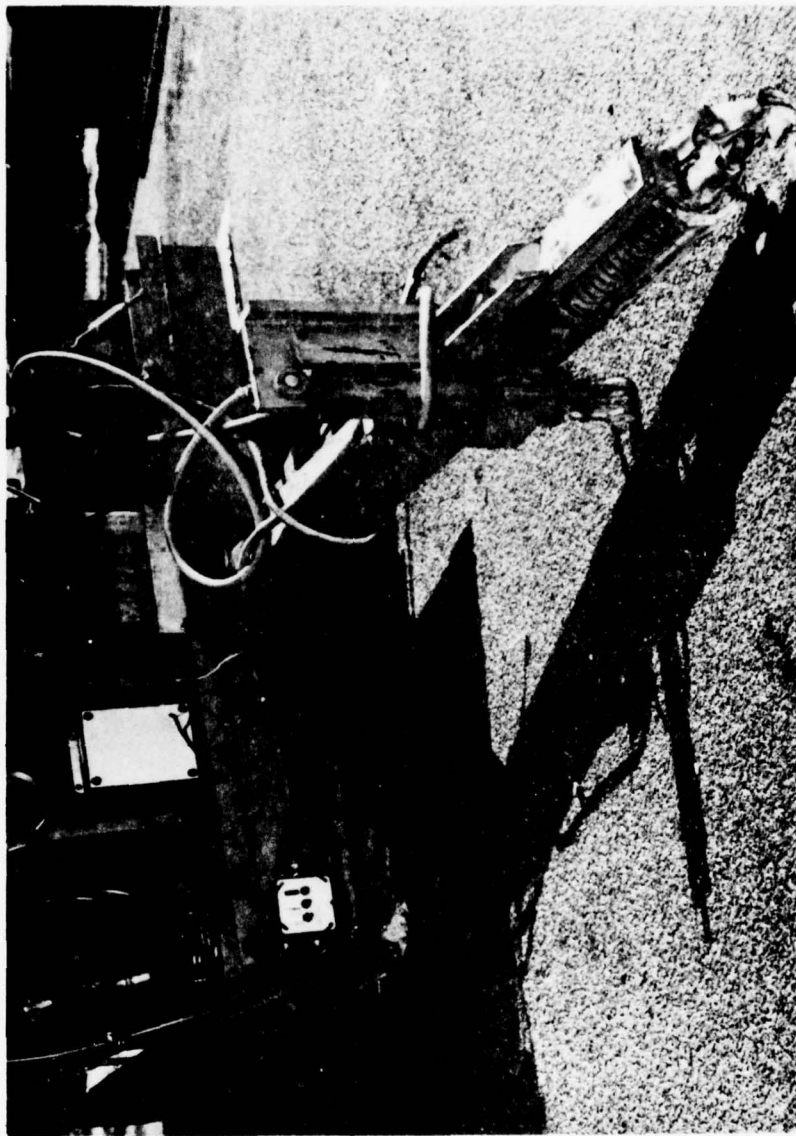

Figure 28. Towbar assembly, with spring-loaded hitch, attached to the front of the SSCV.

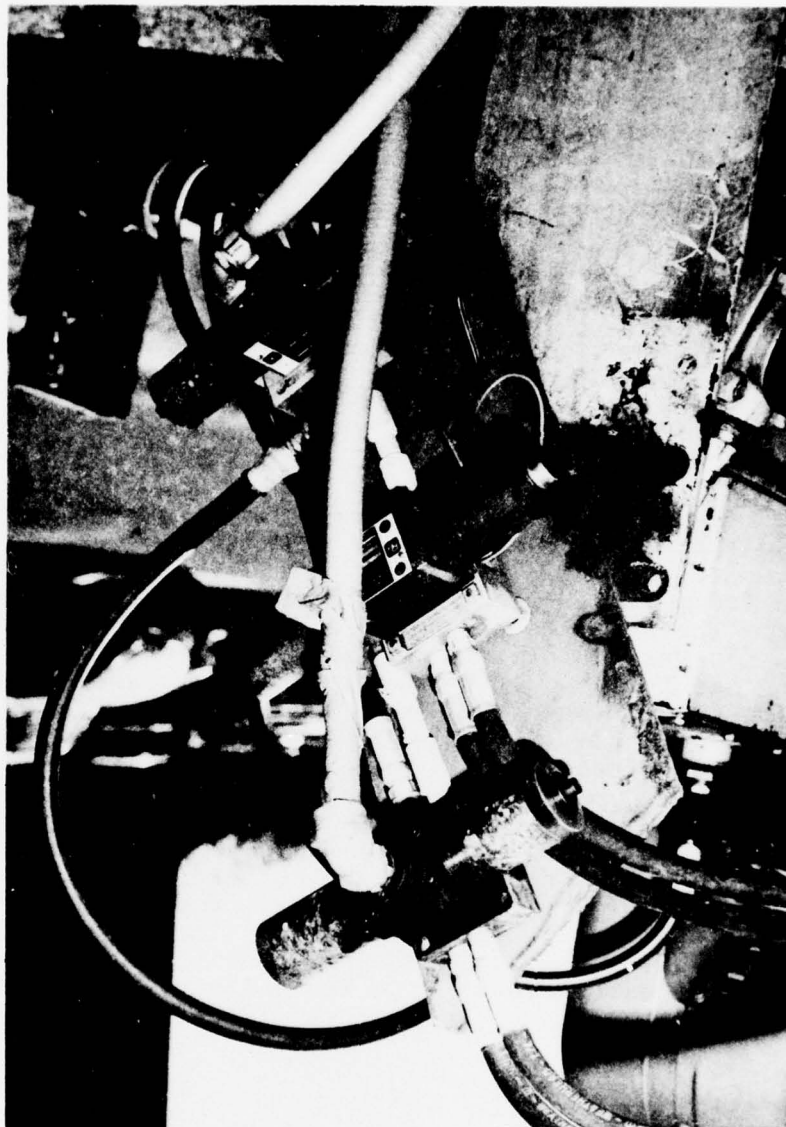

Figure 29. Hydraulic manifold, with three solenoid-actuated valves, mounted on the SSCV.

Tuesday, 14 December

The range was open for tests all morning because of the steady downpour. It was decided to deploy the vehicle to the minimum altitude release target (see Figure 30) where there was extensive surface contamination. The overshoot area contained practice bombs, snakey fins, tires, and other debris.

After digging along an arc around the target for approximately 180 degrees, the SSCV throat became overloaded with a 4-foot bush, tires, and wet sand. When it was noticed that the spring-loaded hitch was about to release, the TD-20 was stopped and an attempt was made to pull the bush from the digging bed of the SSCV; the bush was too deeply rooted. The TD-20 was rocked from forward to reverse gear, using the remote control, and a retaining pin on the spring-release hitch was broken off by the reverse movement of the pintle ring (Figures 31 and 32). The towbar was chained to the TD-20 hitch so that digging could continue.

Digging resumed successfully around the target. When the TD-20 was turned almost 90 degrees left to begin a second circuit around the target, the right wheel of the SSCV sunk deeply into the sand and the frame tilted about 45 degrees, overloading the leveling cylinder. The vehicles were halted so that the situation could be examined. It was discovered that the solenoid valve controlling self-leveling had failed. It was removed and a spare solenoid was mounted in its place. When the TD-20 was moved forward, pulling the SSCV out of the hole, the self-leveler responded correctly and the vehicle righted itself.

A radio message was received that the Seabees were required to take the TD-20 to Rodman at 1300 hours. This allowed only enough time for the test crew to return to Tower No. 2, remove the master control box from the prime mover, and tow the SSCV back to the Pinecastle maintenance area with the Hiap truck.* The Wisconsin engine was allowed to continue running during the trip back to the maintenance area so that the self-leveling action could be observed. There was no further difficulty with the leveling device.

Wednesday, 15 December

An inventory was made of the SSCV parts stored in the conex box at the PEWR maintenance area. Measurements were made of the SSCV belts and drive system and still photographs were taken of the modifications that had been performed on the vehicle during the previous week.

* The Hiap truck, with articulated hoist crane, is used by EOD personnel for bomb disposal.

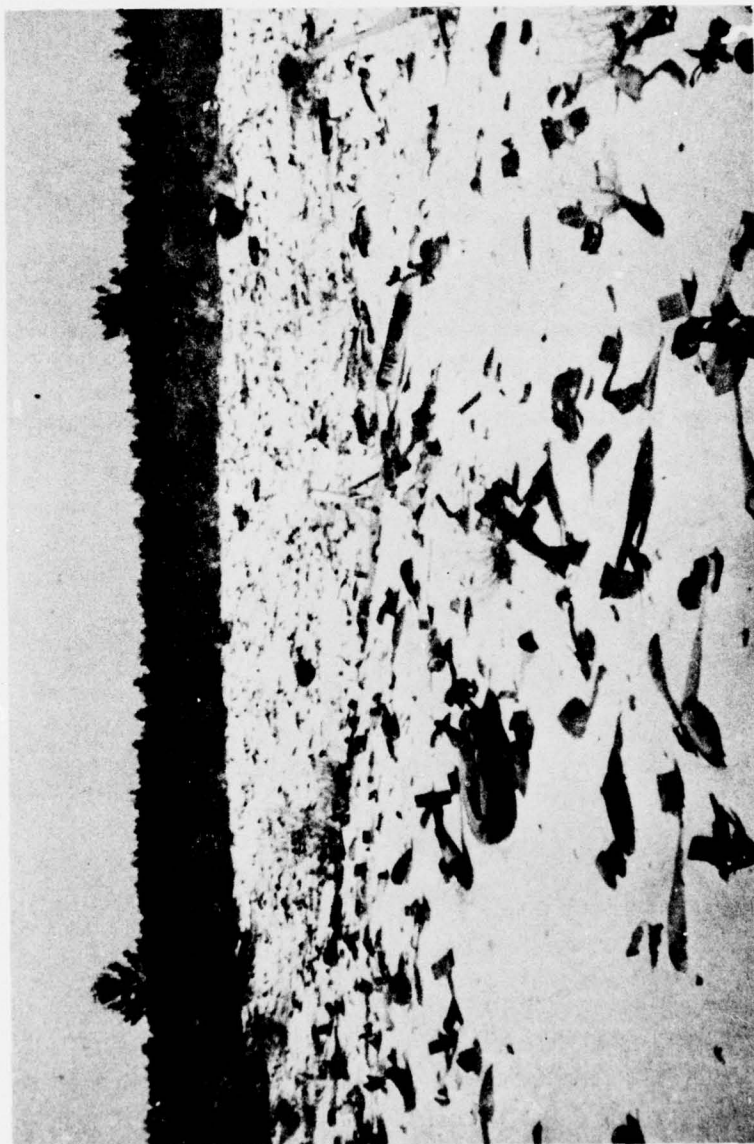

Figure 30. Minimum altitude release target; area for final test of modified SSCV.

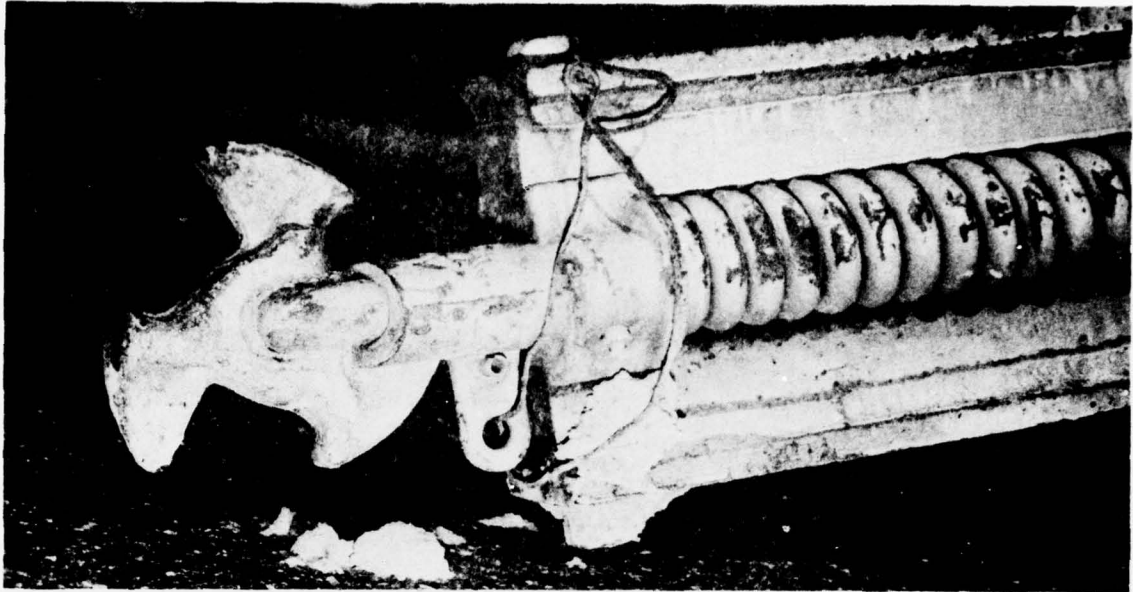

Figure 31. Spring-loaded hitch after failure of retaining pin.

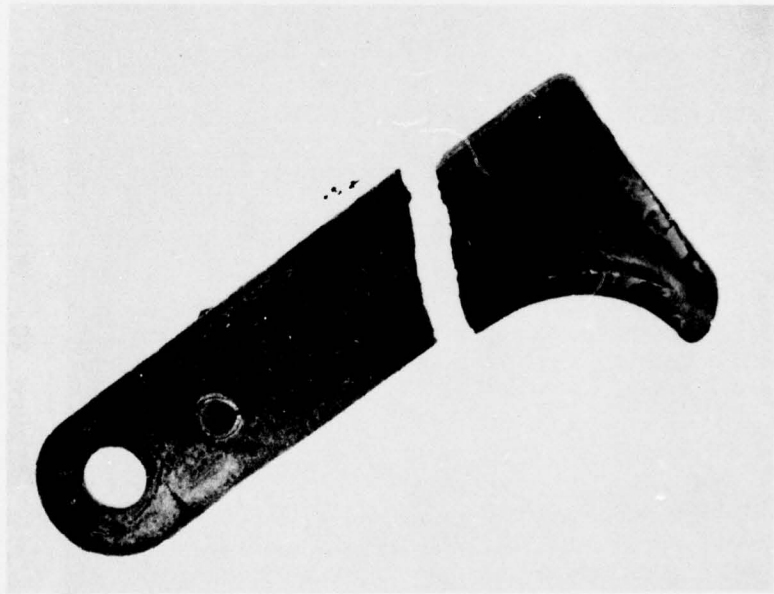

Figure 32. Fractured retaining pin from spring-loaded hitch.

Summary of Test Results. It was the purpose of these tests to determine the effectiveness of the Phase II modifications on the SSCV. The extent of evaluation was curtailed by continual bad weather and sporadic availability of the range because of a two-week fleet exercise. Each objective of the tests is restated below with pertinent remarks.

Determine effectiveness of self-leveling action on the SSCV.

The use of self-leveling proved to be a valuable asset and should be considered essential in future clearance vehicle developments. The configuration of the leveling cylinder used for these tests was not the most efficient that could be used. The manner in which the cylinder was mounted was the simplest that could be employed on the prototype vehicle; however, it suffered from a loss of mechanical advantage when severe tilting occurred. The one instance on the range where the self-leveler failed to respond was a result of a sudden roll of the SSCV frame to the right, moving the center of gravity so far outside the thrust axis of the cylinder that it could not respond. In every other instance, the vehicle stayed reasonably level. In a future design, consideration should be given to the use of two cylinders (one on each side) with the axle on a roll axis in the center. This would allow two shorter hydraulic cylinders to work in conjunction--one pulling down and the other pushing up--and the center of gravity of the SSCV would remain within the thrust axis of each cylinder.

Evaluate improved hopper door configuration.

This modification was undertaken to assure positive closing of the hopper door, prevent heavy loads in the hopper from pushing the door open, and to position the hydraulic cylinders so that the cylinder arms are protected from the weather in the normal (door closed) position. All the expected advantages were demonstrated successfully in the new configuration. A resulting disadvantage was that the sides of the hopper tended to spring outward when the hopper door was open. Wiper plates were attached to the upper corners of the hopper body to prevent binding of the door during the closing sequence. The entire problem can be eliminated in a future design by attaching a horizontal strut across the upper corners at the rear of the hopper. Although no interference was noted in the hopper door operation, future design should allow more freedom of swing at the bottom end of the hydraulic cylinders on the sides of the hopper.

Test operational advantages of longer towbar and spring-release hitch.

The longer towbar was used to improve the turning radius of the SSCV when in tandem with the prime mover. Several very tight turns were made and no difficulty was experienced in effecting a turn with the TD-20 at 90 degrees to the SSCV. The two vehicles could be turned through 180 degrees on a 20-foot wide road. The hydraulic jack mounted on the towbar could not be

tested in the field because of the necessity to eliminate its hydraulic function from the manifold, as described in the earlier discussion of the modifications. The spring-loaded hitch performed adequately in the normal forward-tow operations; the hitch mechanism fractured when the TD-20 was in reverse and the pintle ring pushed against the retaining pin. The future design for the SSCV towbar should incorporate a different concept which allows telescoped extension of the towbar when the drawbar pull exceeds a preselected load.

Test advantages of an on-board TV monitoring system.

The continuing bad weather conditions prevented the TV system from being adequately tested. The remote control switching between cameras was demonstrated and the transmitter was used over a range of approximately 100 meters.

Evaluate the redesigned master control box.

The new control box offered considerably more flexibility in the selection of control functions and the air hose/cylinder arrangement was more efficiently arranged. No serious problems developed in the use of the control box or in adapting it to the operator controls on the prime mover.

As an additional fail-safe feature, one of the spare cam-microswitch positions was used as an accelerate-decelerate control. This had a demonstrated advantage during the field test because it prevented inadvertent acceleration during the shifting of gears, particularly in the reverse mode.

It would be advantageous in future designs of the control box to reduce the sensitivity of the travel control functions. The operator of the remote control transmitter need only move the travel joystick a slight amount to shift gears or to command right and left turns. The control need not be this sensitive and, in fact, requires cautious movement of the joystick to prevent accidental command of unwanted travel responses.

Determine advantages of shock-mounted digger platform.

When the modification was made to the lifting arm on the axle that controls the height of the digging bed, the distance to be spanned from the bellcrank to the digging bed was greater than could be accommodated by the shock mounts. This prevented the test of the shock-mount feature at this time. A depth-limiter was installed on the digger bed lift cylinder.

CONSIDERATIONS FOR SECOND GENERATION DESIGN

The following checklist highlights the design improvements that should be considered for the SSCV, Mod 1:

- *Self-leveling.* This mechanism was a definite asset; the hydraulic lifting action should be applied to the outermost dimensions of the SSCV frame, preferable with two cylinders working in conjunction, to maintain a mechanical advantage in extreme roll actions.
- *Hopper door.* The improved open-close operation and overall design is superior to that originally used. A cross brace is required to maintain hopper body rigidity while the hopper door is open.
- *Longer towbar.* The 6-foot length gave the short turn radius that was sought in the tests. The towbar must be mounted closer to the horizontal than the one used in the tests so that the angle of attack of the digging blade and the main conveyor incline are not too steep for efficient operation.
- *Hydraulic jack (on towbar).* This jack is an important feature but could not be used during the final tests because of the necessity to limit hydraulic functions.
- *Spring-release hitch.* The idea of using a breakaway hitch has merit. The existing hitch failed because it was not adapted to a rigid back-up movement by the prime mover. A retractable (telescoping) hitch, as mentioned in the SSCV Mod 1 design, is a more suitable configuration.
- *TV monitoring system.* The use of TV on board the SSCV needs to be reappraised. There are times when it would be an operational asset; there are also many times when it would not be needed. A search should be made for a tested, ruggedized system that may be available as an off-the-shelf item.
- *Master control box.* The new design was a decided improvement in the control capability of the SSCV and the prime mover. Several additional improvements are needed.
 - a. The receiver should be accessible when the cover is opened so that servo-channel plugs can be interchanged and the plug-in crystal can be reached for selected frequency changes.
 - b. Edges and corners on the bellcrank and lever arms should be rounded to prevent injury to personnel working in the cockpit of the prime mover.

c. The bell crank arms should be notched or ratcheted at intervals that give appropriate adjustment capability to the vee blocks. On two occasions during the recent tests, the vee blocks worked loose, slid down the lever arms, and caused loss of full thrust control on right and left brake positions.

CONCLUSIONS

FEASIBILITY OF MECHANIZING IMPACT RANGE CLEARANCE

Surface Clearance. The preponderance of labor expended on the surface clearance of actively used impact ranges is involved with target maintenance and keeping access roads clear. This labor is almost entirely manual and requires periodic shutdown of the range for two or three days a month for work on just a few target areas. The target maintenance crew may consist of 15 to 20 personnel performing hand-clearance, at least one truck driver, and a supervisor. In addition, when there is a requirement to move large ordnance (e.g., 250-lb. bombs) a truck with a hoist capability is required. The field tests conducted with the SSCV prototype showed that:

1. Surface debris, including 4-foot bomb bodies, can be cleared from the surface effectively by the SSCV, loaded into the hopper and hauled from the impact area.
2. The SSCV can be maneuvered around obstacles and along slopes with grades up to 20 percent.
3. Access roads can be cleared by the SSCV to remove surface material that could cause damage to wheeled vehicles used by the range maintenance crews.
4. The area to be cleared must be surveyed before the SSCV is employed to avoid operational problems with guy wire anchors, wire cable, parachute canopies and shroud lines, and large objects too large for the throat of the vehicle.
5. The SSCV will not operate well in areas with thick vegetation.

Subsurface Clearance. On most impact ranges, no clearance effort is expended on subsurface contamination. In fact, it was ob-

served during the subsurface clearance tests with the SSCV that target maintenance crews will sometimes bury quantities of practice bombs in the target area. If and when an extensive clearance program is undertaken on an impact range (e.g., when the land is to be taken over for another use), the shallow subsurface contamination may be even greater than anticipated because of surface ordnance that had been intentionally buried during target rehabilitation. With regard to subsurface clearance capability, it is concluded that:

1. The SSCV Prototype design is a logical approach to the mechanization of range clearance, not only because of the replacement of personnel-intensive handling of ordnance but also because of the systematic soil-processing technique employed on the vehicle.
2. The SSCV Prototype can process an average of 700 cubic yards of friable soil/sand an hour, separate and load approximately six tons of ordnance and debris before the hopper must be dumped.
3. The SSCV would perform a valuable task in a mass decontamination program where metal detectors would be used by removing the metal scrap that is on the surface and shallowly buried.
4. Wet soil/sand decreases the efficiency of the SSCV performance; the load on the conveyors is significantly increased and the sifting process is degraded.

Remote Control. Radio frequency remote control was incorporated into the SSCV design so that the operator could remain at a safe, standoff distance from the vehicle when operating in areas where live ordnance may be present. The prototype vehicle also has manual controls that permit attended operation of SSCV functions when remote control is not required. The tests of the remote control subsystem showed that:

1. Heavy equipment can be effectively operated by remote control on an ordnance impact range.
2. All the functions required to conduct clearance operations can be achieved through a simple, remote control configuration.
3. Fail-safe devices are required on the clearance vehicle to prevent loss of operator control; absolute requirements are fail-safe measures for loss of transmitted command signals, loss of electrical power on board, and loss of pneumatic control of travel and steering on the prime mover.

RELIABILITY

SSCV Main Frame. The construction of the SSCV was undertaken to provide a means for testing the feasibility of this approach to range clearance. The main frame was built to withstand the estimated rigors of the tests that were conducted and, at the same time, adhere to the cost requirements of the contract. The field tests indicate that:

1. The SSCV main frame was of sufficient strength to perform without structural failure through the test series.
2. Additional structural tests should be conducted, such as the effect that minor detonations would have at various points on the vehicle.
3. A design for a larger SSCV would require commensurate increase in the strength of the main frame; replacing the 5-foot cutting swath with an 8-foot swath would, for example, increase the average soil handling requirement from 700 to 1200 cubic yards per hour.

SSCV Components. The vehicle components subject to failure during the tests were: the tires, the Draper sections on the main conveyor, the stapled seams on the Pylon conveyor belts, and the towbar hitch. With regard to these failures, it is concluded that:

1. The SSCV should move on free-wheeling tracks, rather than rubber tires; flat tires on an impact range cannot be avoided and, when they occur, it is difficult to change the tires in the field.
2. The Draper sections (rods), although easily replaced in the field, develop bends that introduce vibration in the main conveyor operation; consideration should be given to additional reinforcing links in the sections.
3. The seams on the Pylon belts on the fines conveyor parted several times under extreme loads of sand; the seams should employ heavy-duty stitching rather than the staples installed when the vehicle was fabricated.
4. The breakaway hitch on the towbar is considered necessary to protect the SSCV from damage when a large object is hit by the digging blade; the spring-loaded hitch employed during the field tests was not of sufficient strength.

APPENDIX

DESIGN OF A SECOND GENERATION
SURFACE/SHALLOW-SUBSURFACE
CLEARANCE VEHICLE- SSCV MOD 1

INTRODUCTION

The prototype version of the Surface/Shallow-subsurface Clearance Vehicle (SSCV) was built to test the practicality of mechanizing some aspects of clearing ordnance impact ranges. In the prototype test program, the feasibility of collecting a variety of ordnance that is on the surface and shallowly buried was demonstrated. A number of modifications were made to improve the operation of the SSCV and these were evaluated with regard to incorporation in subsequent vehicle design.

DESIGN

GENERAL DESCRIPTION

The SSCV Mod 1 design is for a vehicle larger in size and more versatile than the prototype feasibility model. The vehicle, shown in Figure A-1, would be approximately 30 feet (9.14 meters) long, 8 feet (2.44 meters) high, and 8 feet (2.44 meters) wide. The towbar would add an additional 5-1/2 feet (1.68 meters) to the length and the cross conveyor (soil conveyor) an additional 3 feet (0.91 meters) to the overall width. Referring to the numbered call-outs in Figure A-1, the following features reflect the major advances in the second-generation design:

- ① Extendable towbar. If the SSCV encounters an obstacle beyond its digging capability, the prime mover will continue forward another 3 feet (0.91 meters), extending the telescoped towbar assembly. As the towbar is extended, a fail-safe switch is activated and the prime mover is stopped within the extended length of the towbar. The prime mover can be backed up to retract the towbar and reactivate the forward travel, when desired.
- ② Adjustable-stroke hydraulic cylinder. This cylinder can be set to give the desired maximum stroke, adjusting the depth of the digging blade.
- ③ Shock absorber. The shock absorber is built into the cylinder that controls the depth of the digging blade platform. If the blade strikes a large object, the shock absorber reacts so as to immediately raise the digging blade assembly, then lower it slowly. This will prevent damage to the blade and to the main conveyor bars that are moving under the vehicle.
- ④ Digging depth arms. The digging blade assembly is connected to the depth adjustment mechanism on each side by rigid bars. This configuration causes the shock absorber to function and eliminates the need for manual adjustment of the digging depth.

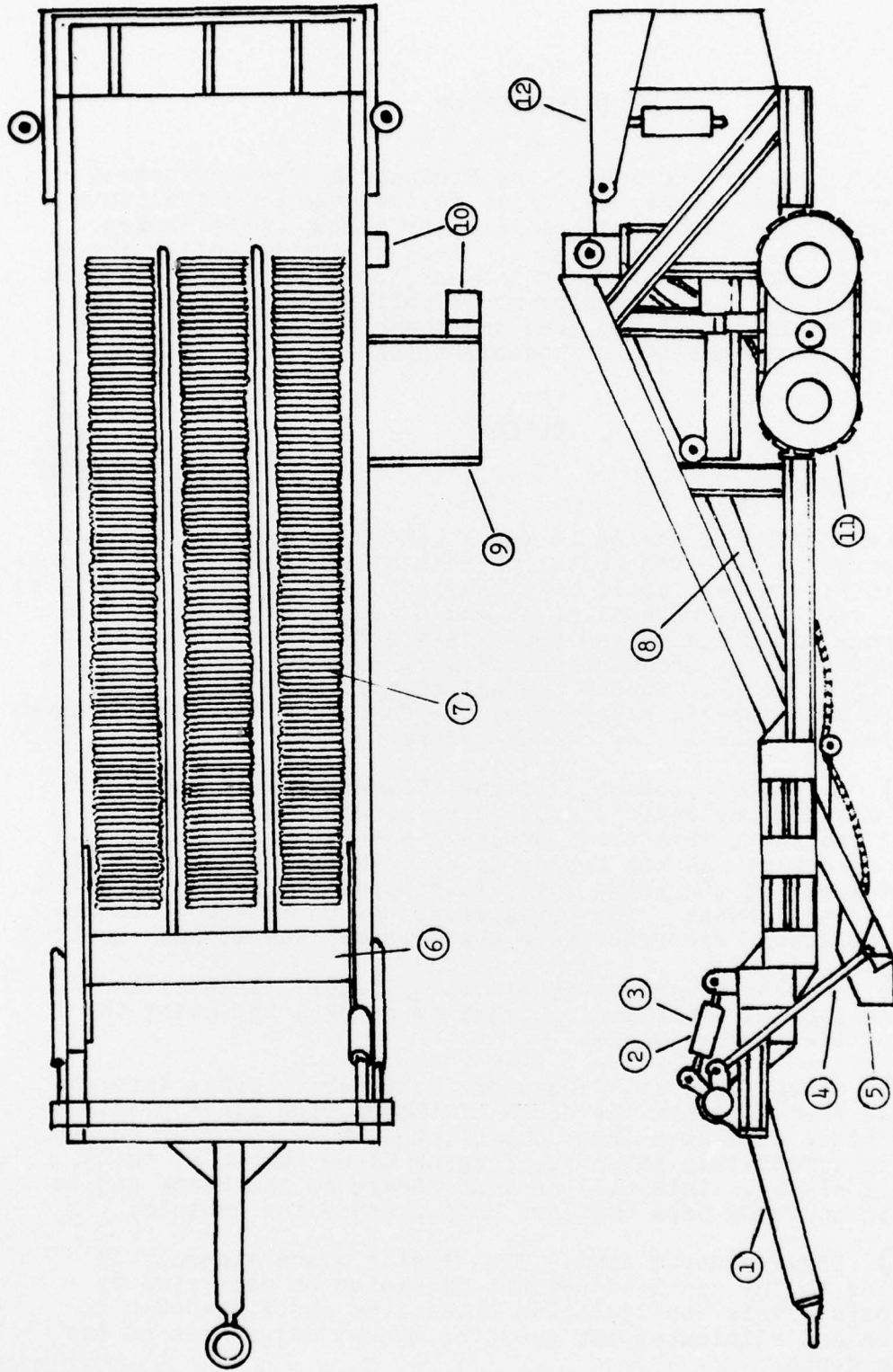

Scale: 1/4" = 1'-0"

Figure A-1. SSCV, Mod. 1.

⑤ Cheek plates. These plates extend forward on each side of the digging blade. They serve to divert the material that is accumulating in front of the blade onto the digging bed and prevent light-weight items from being swept aside in a "bow-wake" action.

⑥ Digging blade gap control. The area between the back of the digging blade and the front edge of the main conveyor is open approximately 8 inches (20.32 centimeters) to allow debris and small ordnance items to be rolled up onto the main conveyor from beneath the vehicle. Pylon flaps prevent material from falling through the gap from the top of the digging blade.

⑦ Main conveyor. The main conveyor consists of three draper chain assemblies. Each draper chain is comprised of interlinked 28-inch (71-centimeter) rod sections.

⑧ Fines conveyor. The fines conveyor consists of three Pylon belts running directly beneath and at the same speed as the main conveyor. Each Pylon belt is 24 inches (61 centimeters) wide.

⑨ Soil conveyor. The soil conveyor is a Pylon belt, 36 inches (91.4 centimeters) wide and runs at approximately twice the speed of the main and fines conveyors. This belt is formed into a "U-channeled" conveyor and is swept upward at its discharge end to provide the proper soil windrow trajectory. The soil conveyor can be hinged near the main frame of the SSCV to allow folded storage during transport.

⑩ Hydrostatic drive. The conveyor system is powered by hydraulic motors. The main and fines conveyors are moved at the same speed and can be driven by a single hydraulic motor; a sprocket chain drive would be used between the main and fines conveyor drive pulleys.

⑪ Tracks. The SSCV Mod 1 will move on freewheeled tracks. The track assembly would be a Caterpillar 931 unit, or equivalent, mounted on the SSCV frame on a self-leveling axle.

⑫ Hopper. The hopper will have a 6 cubic-yard (4.6 cubic-meter) capacity and store approximately 8 tons (7.26 metric tons) of debris. The hopper door will incorporate a positive closing action and overhead swing to facilitate dumping. The hopper door will be operated hydraulically.

DESIGN GOALS

The following design goals have been established for the SSCV Mod 1 System:

- Pick up and load ordnance and debris up to 6-foot (1.83-meter) body length.
- Collect ordnance and debris on the surface and at selectable depths to a maximum of 18 inches (45.72 centimeters) in friable soil, over a cutting swath of approximately 8 feet (2.44 meters).
- Primary separation from the soil of objects larger than 37 mm.
- Determination of feasibility of secondary separation techniques for ferrous objects smaller than 37 mm.
- Provide selectable cutting depths to accommodate soil conditions and contamination densities.
- Provide for subsequent TV monitoring capability, with a link to the remote operator, that will present views of the hopper, main conveyor, digging blade, and the surface conditions in front of the prime mover.
- Provide for optional use of remote control operation on both the prime mover and the SSCV.
- Incorporate fail-safe provisions to prevent loss of prime mover control in the event of failure of electronic, electrical, hydraulic, or pneumatic subsystems.

DISTRIBUTION

<p>Defense Documentation Center (TRS) Cameron Station, Building 5 Alexandria, VA 22314</p>	<p>2</p>	<p>Chief, U.S. Army Technical Detachment Naval Explosive Ordnance Disposal Facility Indian Head, MD 20640</p>	<p>2</p>
<p>Chief of Naval Operations (OP-9821F1) Department of the Navy Washington, DC 20350</p>	<p>1</p>	<p>Commander Detachment 63, HQ Ogden Air Logistics Center (AFLC) Naval Explosive Ordnance Disposal Facility Indian Head, MD 20640</p>	<p>2</p>
<p>Chief of Naval Operations (OP- 323G) Department of the Navy Washington, DC 20350</p>	<p>3</p>	<p>Officer-in-Charge Marine Corps Detachment Naval Explosive Ordnance Disposal Facility Indian Head, MD 20640</p>	<p>2</p>
<p>Commander, Naval Sea Systems Command (SEA-033) Washington, DC 20362</p>	<p>2</p>	<p>Headquarters, Marine Corps Deputy Chief of Staff (RD&S) (Attn: Code RD) Washington, DC 20380</p>	<p>1</p>
<p>Commander, Naval Sea Systems Command (SEA-663C) Washington, DC 20362</p>	<p>2</p>	<p>Marinco Ltd. Suite 101 6269 Leesburg Pike Falls Church, VA 22044</p>	<p>3</p>
<p>Commander Explosive Ordnance Disposal Group ONE APO, San Francisco, CA 96611</p>	<p>2</p>	<p>Chairman Department of Defense Explosives Safety Board Washington, DC 20315</p>	<p>1</p>
<p>Commander Explosive Ordnance Disposal Group TWO Ft. Story, VA 23459</p>	<p>2</p>		
<p>Commanding Officer, Naval School Explosive Ordnance Disposal (SD) Naval Ordnance Station Indian Head, MD 20640</p>	<p>2</p>		