

AD-A045 069

FOREIGN TECHNOLOGY DIV WRIGHT-PATTERSON AFB OHIO
MERKEL THEORY OF EVAPORATIVE COOLING, (U)
MAY 77 W HAUSSLER, K STADT

F/G 20/13

UNCLASSIFIED

FTD-ID(RS)I-0331-77

NL

| OF |

AD
A045 069



END

DATE

FILMED

11-77

DDC

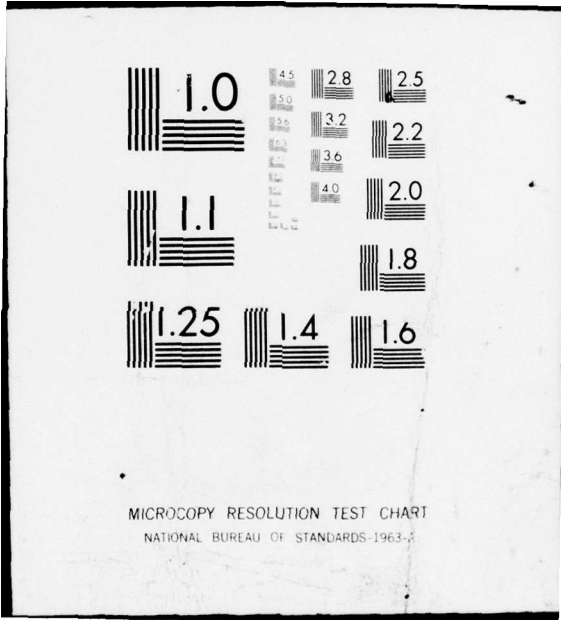

MICROCOPY RESOLUTION TEST CHART
NATIONAL BUREAU OF STANDARDS-1963-A

AD-A045069

FTD-ID(RS)I-0331-77

1

FOREIGN TECHNOLOGY DIVISION



MERKER THEORY OF EVAPORATIVE COOLING

by

W. Haussler, Karl-Marx-Stadt

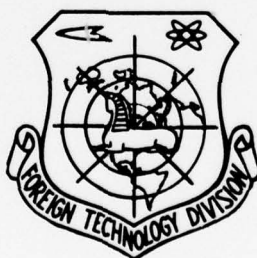

DDC
RECEIVED
OCT 11 1977
RECEIVED
D

Approved for public release;
distribution unlimited.

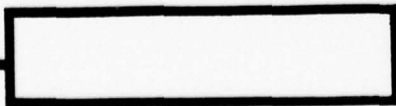

| | |
|---------------------------------|---|
| ACCESSION for | |
| NTIS | White Section <input checked="" type="checkbox"/> |
| DGC | Buff Section <input type="checkbox"/> |
| UNANNOUNCED | <input type="checkbox"/> |
| JUSTIFICATION | |
| BY | |
| DISTRIBUTION/AVAILABILITY CODES | |
| Dist. | AVAIL. and/or SPECIAL |

FTD- ID(RS)I-0331-77

EDITED TRANSLATION

A | 23
EC

FTD-ID(RS)I-0331-77 9 May 1977
 CSL74086720 *FTD-77-C-000520*
 MERKER THEORY OF EVAPORATIVE COOLING
 By: W. Haussler, Karl-Marx-Stadt
 English pages: 23
 Source: Energietechnik, Berlin, Vol 21, Nr 5,
 May 1976, PP. 200-205
 Country of origin: East Germany
 Translated by: Gale M. Weisenbarger
 Requester: AEDC/DYF
 Approved for public release; distribution unlimited.

| | |
|---|---|
| <p>THIS TRANSLATION IS A RENDITION OF THE ORIGINAL FOREIGN TEXT WITHOUT ANY ANALYTICAL OR EDITORIAL COMMENT. STATEMENTS OR THEORIES ADVOCATED OR IMPLIED ARE THOSE OF THE SOURCE AND DO NOT NECESSARILY REFLECT THE POSITION OR OPINION OF THE FOREIGN TECHNOLOGY DIVISION.</p> | <p>PREPARED BY: TRANSLATION DIVISION FOREIGN TECHNOLOGY DIVISION WP-AFB, OHIO.</p> |
|---|---|

FTD- ID(RS)I-0331-77

Date 9 May 19 77

MERKEL THEORY OF EVAPORATIVE COOLING

Prof. Dr. Engineer Habilitatus Werner Haussler, College of Science and Technology Karl-Marx-Stadt, Heat Engineering

1. THE PROBLEM OF EVAPORATIVE COOLING

The increasing water shortage in all industrial countries precludes the use of fresh water for cooling, with its subsequent discharge into the environment following heating in the heat exchanger, in all but exceptional cases. The need for fresh water can be reduced to a few percent if a conversion is made to recirculating operation with cooling by evaporation in accordance with Fig. 1. The design of the apparatus which is necessary for this is complicated considerably by the fact that no clear exchange surfaces in the sense of the theory can be defined for coupled heat and mass transfer

between the circulating water and the ambient air. For this reason experimental research is prominent.

In power-generating technology up until now the "cold" end of the process has received less attention than the processes in the steam generator and in the turbine, although the energy conversion can be improved just as effectively by colder cooling water as by optimizations of heat input and expansion of the working medium. A summary is given below of the most recent state of research in the area of evaporative cooling.

2. THE INTERACTION OF HEAT AND MASS TRANSFER DURING THE EVAPORATIVE PROCESS

During flow through a cooling apparatus as in Fig. 1, the colder external air picks up heat and moisture from the sprayed or sprinkled circulating water and thereby alters its state from t_1, x_1, φ_1 to t_2, x_2, φ_2 . The superposition of the heat and mass transfer also effects an additional cooling of the water if its temperature has dropped below the temperature of the air, which to the observer may seem surprising. The interaction of both transfer processes can best be seen in the h, x -diagram in which the enthalpy h and the moisture content x are assigned to the coordinate axes of the oblique representation. Thereby a direct view results for heat and mass

transfers.

Following the international adoption of the h, x -diagram [1] there should also be more vigorous use in the cooling tower sector in order to facilitate the exchange of research results with other branches of science and technology in which this basis for calculation is already employed (air conditioning, drying and refrigeration technology). The tabular representations which are still preferred in the "cooling tower regulations" [2] cannot achieve the overview and graphicness of the h, x -diagram, the readability of which can be easily matched to the limits of error of cooling tower research. A diagram with internationally recognized format and material values remains a worthwhile goal for future development [3].

A boundary layer temperature θ , determining for heat and mass transfer, is accepted for the processes in the water trickling down during re-cooling in accordance with Fig. 1. An equilibrium state is created on the surface of the water and the air particles assume the temperature θ . Their water vapor partial pressure becomes equal to the saturation pressure p_s at θ . Therefore in the h, x -diagram the equilibrium state is found on the saturation line $\psi = 1.0$ in accordance with Fig. 2.

For convective heat transfer \dot{q}_k between the water and the air

the familiar relationship is valid:

$$(1) \quad \dot{q}_K = \alpha(\theta - t)$$

with α for the heat transfer number.

The quantity of water evaporated is expressed by:

$$(2) \quad \dot{m}_V = \sigma(x_s - x)$$

x_s in this case is the saturation content at θ and x the moisture content of the core flow, σ is the evaporation number.

The "air number"

$$(3) \quad \lambda = \frac{\dot{m}_L}{\dot{m}_W}$$

as the ratio of the volume of air passing through t_{w2} to the volume of water \dot{m}_L , has a determining effect on the final water temperature \dot{m}_w attainable during re-cooling. In the case of large quantities of air the air state L (t, x) in Fig. 2 remains practically unchanged and there occurs a clear cooling of the water, the entry state of which $A(\theta_A, x_{SA})$ lies above the air temperature so that the quantity of heat \dot{q}_K is transferred to the air convectively. In F the

temperatures are balanced ($\theta_B = t$, $\dot{q}_K = 0$) while in C and D the heat flow reverses its direction and now heat is transferred increasingly from the warmer air to the cooler water.

For the mass transfer, according to Eq. (2) the driving force is the difference in the moisture content between the saturation state x_s on the boundary layer and x in the core flow of the air. It is greatest in state A and reduces through B, C to D. The mass flow remains unidirectional from the boundary layer to the air as is shown on the right in Fig. 2. The necessary heat requirement for evaporation

$$(4) \quad \dot{q}_v = \dot{m}_v r$$

results from the product of \dot{m}_v according to Eq. (2) and the heat of evaporation r at a surface temperature θ which can be taken from vapor tables.

In the interaction of heat and mass transfer the water in state A has the quantity of heat $\dot{q} = \dot{q}_K + \dot{q}_v$ to deliver if there is no external heat input, thus the process proceeds adiabatically. The water will subsequently cool and even after reaching state B ($\dot{q}_K = 0$) its heat release is not yet finished since it still has to completely supply the heat requirement for evaporation \dot{q}_v . Only following cooling below B does the now warmer air begin to contribute to the

heat of evaporation, respectively, can the heat supply of the water $\dot{q} = (\dot{q}_v - \dot{q}_k)$ decline, state C. The moisture content difference $(x_s - x)$ has simultaneously become smaller and heat and mass flow are now oppositely directed. Finally a boundary state is reached in which the heat supply from the air just suffices to compensate for the heat of evaporation: $\dot{q}_k = \dot{q}_v$. This state is called an adiabatic steady state, it corresponds to point D in Fig. 2 and means that the water is not giving off any more heat: $\dot{q} = 0$. In D is the lowest temperature to which one can cool water with air of a preassigned state. State D is therefore also designated as the "cooling limit."

Also valid for the state of adiabatic stability are

$$(5) \quad \begin{aligned} \dot{q}_k &= \dot{q}_v = \dot{m}_v r \\ \alpha(\theta - t) &= \sigma(x_s - x)r \\ \frac{\alpha}{\sigma} &= \frac{(x_s - x)r}{(\theta - t)} \end{aligned}$$

Experimental proof for the relationships according to Fig. 2 was obtained by the author using an evaporation test stand and measurement of temperature profiles [4]. The investigations of Lienelt were continued using better equipment [5]. In addition, at the present time in the mechanics laboratory of the College of Science and Technology Karl-Marx-Stadt partial pressure profiles are being recorded [6]. In Fig. 2 the temperature and partial pressure

profiles are schematically represented.

The adiabatic stability state D is attained in the cooling tower for $\lambda = \infty$. In the case of quantities of water which are large in relation to the amount of air passing through the system, i.e., $\lambda \approx C$, the boundary layer state (θ, x_s) of the incoming water remains unchanged and the air state I is drawn to it rectilinearly. In practical operation one strives for the lowest possible cold water temperature t_{w2} but hardly gets below E since the air throughput and the exchange passages are limited. For an evaluation of the total process and its laboratory simulation it is apparently necessary to determine not only the inlet states of the air and water but also their outlet states.

3. MERKEL THEORY OF EVAPORATIVE COOLING

The classic work in the area of evaporative cooling was done by Merkel [7] as a dissertation for habilitation at the College of Science and Technology Dresden. In it he used the relationship

$$(6) \quad \frac{\alpha}{\sigma} = c_{pf}$$

which Lewis [8] derived theoretically under the assumption that there is no temperature gradient present in the water, i.e., there is an

adiabatic stability D in accordance with Fig. 2. c_{pr} in this case is the specific heat of the moist air.

Through elementary heat and mass balances and using Eq. (6) and certain simplifications Merkel arrived at his fundamental equation

$$(7) \quad \dot{m}_w dt_w c_w = (h_w - h_L) dA$$

Here h_w is the enthalpy of saturated air at the water temperature t_w and h_L is the enthalpy of the air in the core flow. The relationship states that the heat loss of the water depends only on the enthalpy of the air, but not, however, on the temperature t and the moisture content x .

Merkel's fundamental equation has entered the international literature and is generally used today for the heat-engineering designing of cooling towers. For evaluating measurements one converts

$$(8) \quad K_V = \frac{\sigma A}{\dot{m}_w} = \int_{t_{w1}}^{t_{w2}} \frac{c_w dt_w}{(h_w - h_L)}$$

The integral is solved using an approximation method, e.g., after Spangewacher [9]. The dimensionless expression K_V is designated as the evaporation number and it characterizes the cooling capacity of a

given design.

Merkel attempted to confirm his fundamental equation experimentally, whereby he was primarily concerned with checking Lewis' law, Eq. (6). His test results are scattered in a wide range. If they are plotted so that

$$(6a) \quad Z = \frac{\alpha}{\sigma \cdot c_{p_f}}$$

represents the relationship of the driving potential $\Delta x = (x_s - x)$ to $\Delta t = (\theta - t)$ then there results a median curve with a surprisingly small spread which permits one to presume a correlation of the Z-values to the position of the charge of state in the h, x-diagram. The tests are to be arranged between A and B according to Fig. 2 and display Z-values > 1.0 with an increasing difference in comparison with Eq. (6) during the approach to E. During tests on air washers below D, Z also resulted less than 1.0, while in the state of adiabatic stability Eq. (6) could be generally confirmed.

In spite of the unsatisfactory experimental results according to Fig. 3 Merkel made the bold statement that Eq. (5) and (6) are completely valid in the working range of cooling towers. This provoked the opposition of other researchers.

In deriving the fundamental equation (7) the following simplifications were also made:

- a) the temperature drop in the water is disregarded ($t_w = \theta$),
- b) the evaporating quantity of water \dot{m}_v is disregarded,
- c) the heat of evaporation r and the specific heat c_{pf} are introduced as mean values independent of temperature.

In later works the effect of these approximations was examined and uncertainties in the determination of the state of the exhaust air were pointed out. A final clarification of the relationships according to Fig. 3 was attained with new tests.

4. RECENT STUDIES OF MERKEL'S THEORY OF EVAPORATIVE COOLING

The publication by Merkel [7] aroused a greater number of further investigations of the evaporation process which were first carried out in Germany and then increasingly in other countries and which have not yielded uniform results. In particular the course of the curve in Fig. 3 has not been satisfactorily clarified.

An analysis of the international state of development has been made in recent years in two dissertations; one work by Klenke in Braunschweig (FRG) and a work by Mehlig in Dresden (GDR). The strongly contradictory theoretical statements of both authors are not founded on their own measurements.

Klenke [10], in the total process of evaporative cooling according to Fig. 2, differentiates "synonymous transfer" ($t > 0$, air and water cool off, roughly state C) and "opposite transfer" ($t < 0$, air heats up and water cools off, region A approaching B). While for synonymous transfer, in agreement with the considerations of Fig. 2, the heat loss of the water is the difference between the necessary heat of evaporation \dot{q}_v and the heat which is transferred convectively from the air \dot{q}_k , according to Klenke, in the case of opposite transfer only the heat of evaporation is supplied by the water, and the convective heat loss to the air takes place due to the partial condensation of the formed vapor. The measurements of Dienelt [5] contradict this view and confirm the assumptions of Merkel's theory that for $t < 0$, the flow of water has to supply both the heat of evaporation and the heat lost to the air convectively. With a constant change of the air temperature and nearly constant mass transfer conditions the heat loss of the water changed in the case of

opposite transfer. Klenke rejects Merkel's theory and the K_V -methods derived from it but considers Merkel's measurements to be valid and attempts to clarify the contradictions in Fig. 3 using a new theory.

In contrast to this Menlig [11], in agreement with international experience, considers Eq. (7) to be suitable for predetermining changed operational and design conditions of cooling towers from test data and has come to grips with the error possibilities which arise from the simplifications pointed out at the end of Section 3 as compared with an "expanded fundamental equation" (derived taking full account of the outlet conditions for heat and mass transfer). He estimates that with Eq. (7) the K_V -values, on an average, are calculated 12 o/o too low, but in practical application the errors are compensated for to a great extent by the double introduction of the fundamental equation.

According to Menlig the discrepancies between theory and experiment according to Fig. 3 can be traced back to inaccuracies in the measurements and evaluations by Merkel and ^{he} points out in particular the uncertainties which come into play as a result of determining the exhaust state using a heat balance.

For final clarification of the relationships, in the mechanics laboratory of the College of Science and Technology Karl-Marx-Stadt,

after sufficient experience had been acquired with measurements on cooling installations through contract research, a test installation was constructed whose measuring section was modeled to a great extent on the apparatus used by Merkel but which contained significant improvements for the regulation of stability states and the acquisition of test data. Special care was used in determining the exhaust state.

Fig. 4 shows the schematic of the installation. In order for the test series to be independent of the ambient air states (temperature and moisture content) and air washer III with preheater IV and afterheater V was installed in front of the measuring section I. The final inlet temperature was controlled by thermostat 3 and kept constant. The quantity of air \dot{m}_L was determined with the standard aperture 16 following a calming section and was blown into the cylindrical transfer vessel through an annular channel. The measurement of the supply air temperature t_1 was accomplished with the resistance thermometer 1 the reading of which was checked with a mercury thermometer 2. The moisture content of the air x_1 was determined with the psychrometer 5 and additionally with the hygrometer 6.

Prior to determination of the exhaust state t_2, x_2 of the air the entrained water droplets were collected in two drop separators.

The exhaust air temperature t_2 was measured with the resistance thermometer 7 and checked with the mercury thermometer 8. Psychrometer 9 and hygrometer 10 were installed for determining moisture content x_2 . For exhaust states near saturation adjustable heating permitted an improved determination of the moisture content x_2 .

The warm water sprayed through the nozzle 13 was passed through a heating unit by a gear pump and having cooled, collected in the sump of the exchange vessel, where, after quantitative measurement in the strainer 17, it was discharged. A sieve installed in front of the nozzle prevented clogging of the outlets. The warm water temperature t_{w1} was measured with the resistance thermometer 13 and checked with the mercury thermometer 15; the cold water temperature t_{w2} was measured with the resistance thermometer 12 and checked with the mercury thermometer 14.

The test installation, as a graduate project attended to by Doctor Dr. of Engineering H. J. Reinicke, was designed and constructed in his own workshop. Following break-in of the installation [13] the investigations were continued in the framework of a project for candidacy in science [14], for which Reinicke was an advisor, by M. S. J. Abdel-Hamid (UAI) for the purpose of clarifying the contradictions between theory and experiment according

to Fig. 3 and between the theoretical statements of Klenke and Mehlig. A significant result is shown in Fig. 5.

In this representation Abdel-Hamid has plotted the mean values Z_m measured by him according to Eq. (6a), with transposition of the coordinates in Fig. 3. In the range of Merkel's tests the new measured values are concentrated between $Z_m = 0.8$ to 1.0. This also serves as proof that Klenke's procedure [10] of considering Merkel's tests to be completely valid, but rejecting his fundamental equation of evaporative cooling and opposing it with a new theory, cannot be successful.

The marked deviations of Merkel's test values from Lewis' law can be traced to imperfections in the employed measuring methods, particularly in the determination of the exhaust state by means of a heat balance, and in the evaluation procedure. In the operating range of cooling towers Merkel's theory remains an appropriate method for re-evaluating acceptance tests to other conditions and for making new designs, and as such it has proved itself internationally. Therefore one must agree with Mehlig [11] that the assumptions and simplifications made by Merkel in developing his fundamental equation have ingeniously made the intricate heat and material exchange processes accessible to calculation.

Fig. 5 also shows tests which were made in the range $t > 6$ and which therefore yield negative values for the ratio $\Delta x/\Delta t$. This range is important for the processes in the air washer of an air conditioning installation and in the USSR particular attention has been paid to the question of why, in the state of adiabatic stability D according to Fig. 2, Lewis' law is generally confirmed and satisfactory agreement between theory and experiment can also be established in region A, but in intermediate states, however, differences occur which cannot be overlooked. Most recently Kokorin [15] summarized the existing experimental material.

Since research is also being conducted on the air conditioning process in the department of heat engineering at the College of Science and Technology Karl-Marx-Stadt, tests with the air temperature above the temperature of the sprayed water were also included in the program by Abdel-Hamid, after Schreiber [16] had determined the Z_m -values shown in Fig. 5 using an air washer. The course of the curve is qualitatively confirmed and points out that under these conditions the analogy is no longer satisfactorily satisfied. The ratio $\Delta x/\Delta t \approx -0.4$ corresponds to adiabatic stability; an increasingly negative value of the ratio indicates a change of the transfer conditions through C toward B.

In the framework of his investigations Abdel-Hamid [14]

developed an additional improved method for determining the appropriate mean values Δx_m and Δt_m if only the initial and final states of the air and water are present as test data; no statements can be made, however, about the intermediate course of the change of state of the air, which would permit a graphic determination of the mean value. Fig. 6 is a schematic representation of the course of changes of state of the air (1 to 2) and water (t_{w1} to t_{w2}) in the t, x -diagram.

In addition he investigated the effect of the simplification $t_w = \theta$, and for laboratory studies of cooling installations, concludes that the water distribution in the model and in the actual structure must lead to similar drop sizes, the water temperature at the inlet should correspond to operating conditions and the inlet states of the air should maximally approach the operating conditions.

LITERATURE

- [1] Häußler, W.: Lufttechnische Berechnungen im Mollier- t, x -Diagramm. Dresden Th. Steinkopff 1969
- [2] Leistungsversuche an Kühltürmen (VDI-Kühlturmregeln) DIN 1947, Ausgabe 1959
- [3] Häußler, W.: Vorschläge zur Vereinheitlichung der Klimadiagramme. Heiz. Lüftg. Haustechn. 14 (1963), S. 114-18
- [4] Häußler, W.: Über die Temperaturprofile beiderseits einer verdunstenden Wasseroberfläche. Die Technik 12 (1957), S. 3-6 u. 66-74
- [5] Dienelt, H.: Verdunstungsversuche an ruhenden Wasseroberflächen. Dissertation TH Karl-Marx-Stadt 1967

- [6] *Plichta, J.*: Untersuchung des Wärme- und Stoffaustausches an Wasserrieselkfilmen auf ebenen senkrechten Platten mit Luft im Gegenstrom. Forschungsbericht des Lehrbereiches Wärmetechnik der TH Karl-Marx-Stadt 1970, unveröffentlicht.
- [7] *Merkel, F.*: Verdunstungskühlung. VDI Forschungsheft 275, 1925.
- [8] *Lewis, W. K.*: The evaporation of a liquid into a gas. *Mechan. Engin.* 44, (1922), S. 325—240.
- [9] *Spangemacher, K.*: Berechnung von Kühltürmen und Einspritzkühlern mit Hilfe einer Verdunstungskennzahl. *BWK 10 (1058) 5*, S. 209—215.
- [10] *Klenke, W.*: Die Wärme- und Stoffübertragung bei der Verdunstungskühlung und die Beurteilung von Kühltürmen. Dissertation TH Braunschweig 1964.
- [11] *Mehlig, J. G.*: Zur Anwendung der *Merkelschen* Hauptgleichung in der Kühlturmtechnik. Dissertation TU Dresden 1966.
- : Die Wärme- und Stoffübertragung bei der Verdunstungskühlung. *BWK 20 (1968) 2*, S. 49—56.
- [12] *Georgi, K.*: Laborverdunstungskühler. Diplomarbeit TH Karl-Marx-Stadt, Bereich Wärmetechnik 1966, unveröffentlicht
- [13] *Fritzsche, B.*: Verdunstungskühlung. Diplomarbeit TH Karl-Marx-Stadt, Bereich Wärmetechnik 1967, unveröffentlicht
- [14] *Abdel-Hamid, M. S. J.*: Untersuchungen zur Theorie der Verdunstungskühlung. Dissertation TH Karl-Marx-Stadt 1970
- [15] *Kokorin, O. Ja.*: Potentiale des Wärme- und Stoffüberganges in Klimaapparaten. *Sbornik 1969, Nr. 27 „Kondizionirovanije vosducha“*, S. 28—38
- [16] *Schreiber, R.*: Ein Beitrag zur experimentellen Untersuchung des gemeinsamen Wärme- und Stoffaustausches in einer Sprühdüsenkammer. Dissertation TH Karl-Marx-Stadt

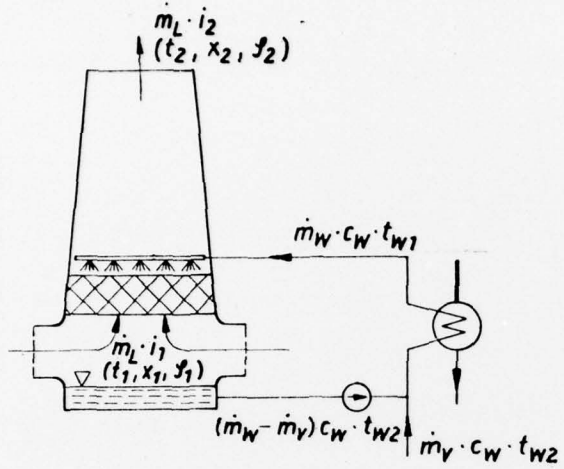

Fig. 1. Schematic of a re-cooling installation. \dot{m}_L air throughput, \dot{m}_w quantity of sprinkled water, \dot{m}_v quantity of vapor as well as the addition of fresh water, 1 inlet state of air and water, 2 outlet state of air and water.

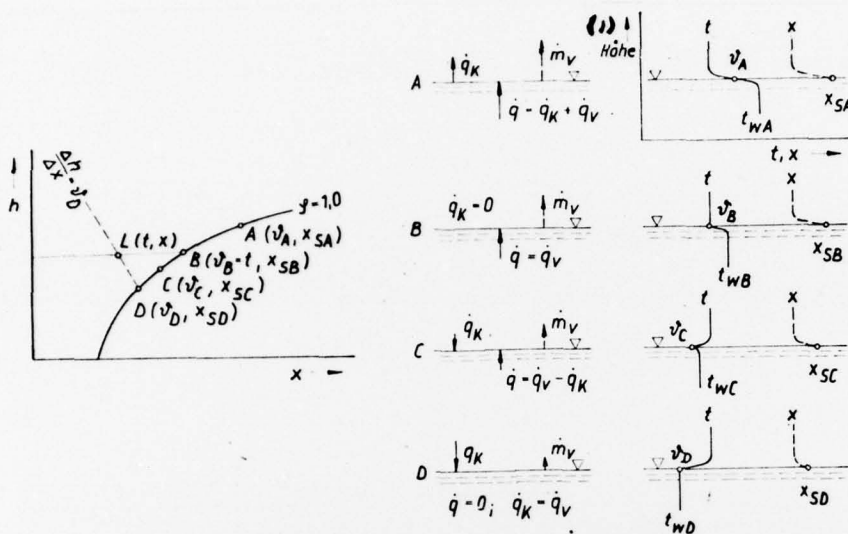

Fig. 2. The interaction of heat and mass transfer during the adiabatic evaporation process, schematically

I (t, x) state of the air

A, B, C and D (t, x) boundary state

\bar{q}_K convective heat flow

\dot{m}_V vapor quantity

\dot{q}_V heat requirement for evaporation

\dot{q} heat loss of the water

((KEY: 1) height.))

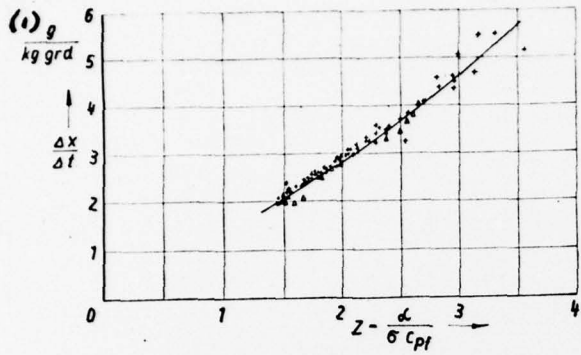

Fig. 3. Merkel's tests for confirmation of Lewis' law: $\frac{\alpha}{\sigma \cdot c_{pf}} = 1.0$

$\Delta x = (x_2 - x_1)$ and $\Delta t = (t_2 - t_1)$ according to Fig. 2. (KEY: 1) g/kg·deg.)

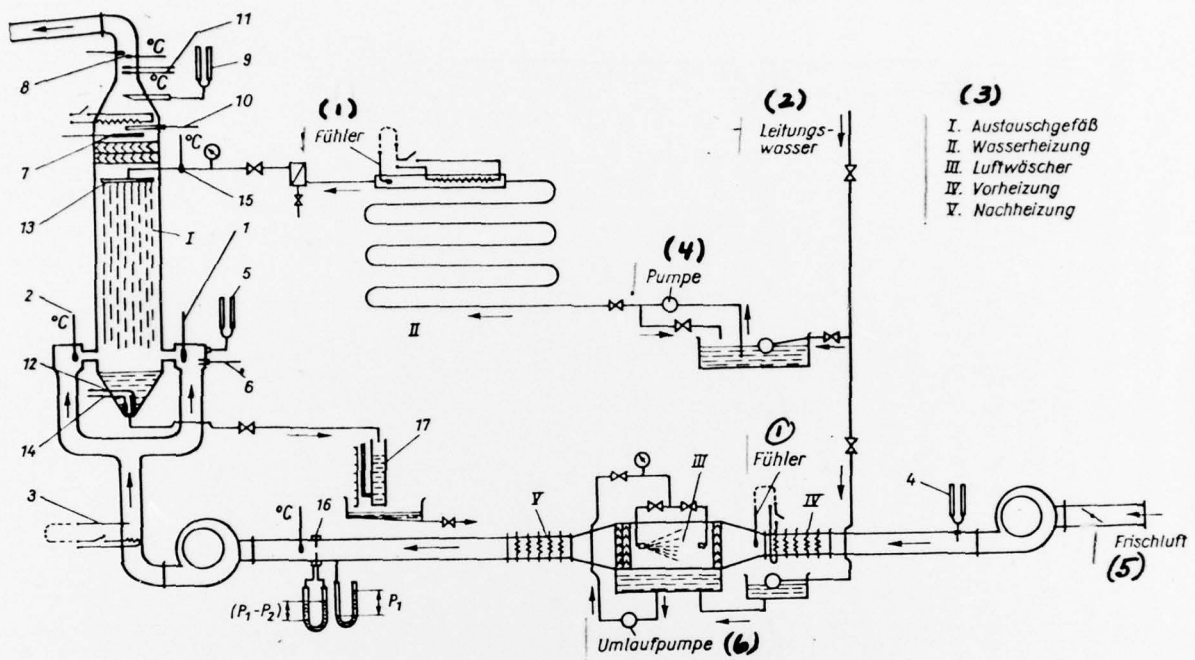

Fig. 4. Schematic of the test installation in the mechanics laboratory of the College of Science and Technology Karl-Marx-Stadt; see text for designations. ((KEY: 1) Sensor; 2) Line water; 3) I. Exchange vessel, II. Water heating, III. Air washer, IV. Pre-heating, V. After-heating; 4) Pump; 5) Fresh air; 6) Circulation pump.

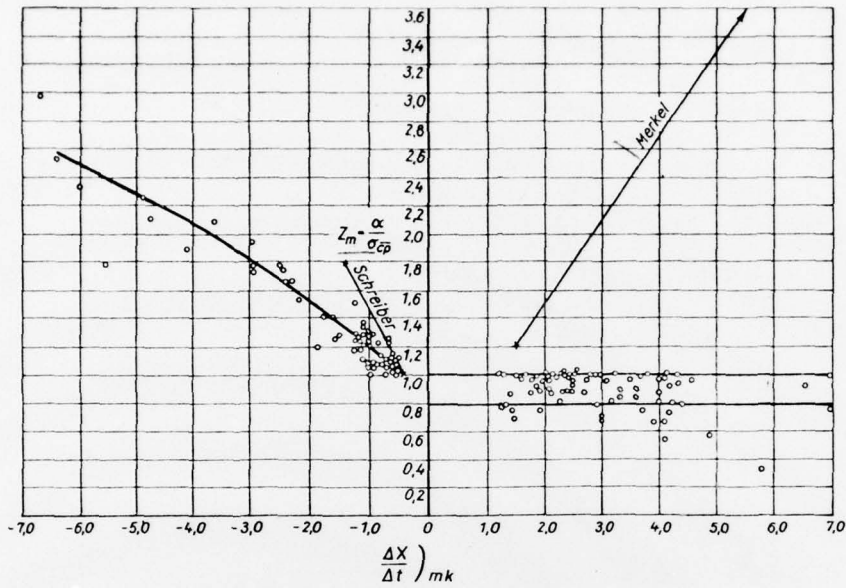

Fig. 5. Vapor measurements on the test installation (Fig. 4) for checking Merkel's theory of evaporative cooling [14].

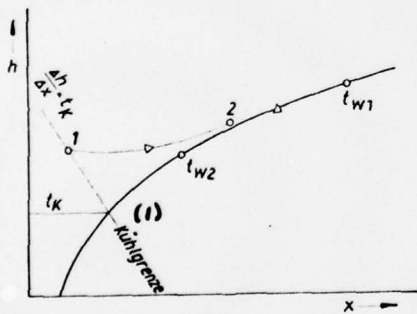

Fig. 6. Change of state of the air (1 to 2) and water (t_{w1} to t_{w2}) in the cooling tower, schematically. ((KEY: 1) Cooling limit.)

UNCLASSIFIED

SECURITY CLASSIFICATION OF THIS PAGE (When Data Entered)

| REPORT DOCUMENTATION PAGE | | READ INSTRUCTIONS BEFORE COMPLETING FORM |
|--|-----------------------|--|
| 1. REPORT NUMBER FTD-ID(RS)I-0331-77 | 2. GOVT ACCESSION NO. | 3. RECIPIENT'S CATALOG NUMBER |
| 4. TITLE (and Subtitle) MERKER THEORY OF EVAPORATIVE COOLING | | 5. TYPE OF REPORT & PERIOD COVERED Translation |
| | | 6. PERFORMING ORG. REPORT NUMBER |
| 7. AUTHOR(s) W. Haussler, Karl-Marx-Stadt | | 8. CONTRACT OR GRANT NUMBER(s) |
| 9. PERFORMING ORGANIZATION NAME AND ADDRESS Foreign Technology Division Air Force Systems Command U. S. Air Force | | 10. PROGRAM ELEMENT, PROJECT, TASK AREA & WORK UNIT NUMBERS |
| 11. CONTROLLING OFFICE NAME AND ADDRESS | | 12. REPORT DATE 5 May 1976 |
| | | 13. NUMBER OF PAGES 23 |
| 14. MONITORING AGENCY NAME & ADDRESS (if different from Controlling Office) | | 15. SECURITY CLASS. (of this report) UNCLASSIFIED |
| | | 15a. DECLASSIFICATION/DOWNGRADING SCHEDULE |
| 16. DISTRIBUTION STATEMENT (of this Report) Approved for public release; distribution unlimited. | | |
| 17. DISTRIBUTION STATEMENT (of the abstract entered in Block 20, if different from Report) | | |
| 18. SUPPLEMENTARY NOTES | | |
| 19. KEY WORDS (Continue on reverse side if necessary and identify by block number) | | |
| 20. ABSTRACT (Continue on reverse side if necessary and identify by block number) 12;13 | | |

DISTRIBUTION LIST

DISTRIBUTION DIRECT TO RECIPIENT

| ORGANIZATION | MICROFICHE | ORGANIZATION | MICROFICHE |
|---|------------|-----------------|------------|
| A205 DMATC | 1 | E053 AF/INAKA | 1 |
| A210 DMAAC | 2 | E017 AF/RDXTR-W | 1 |
| B344 DIA/RDS-3C | 8 | E404 AEDC | 1 |
| C043 USAMIA | 1 | E408 AFWL | 1 |
| C509 BALLISTIC RES LABS | 1 | E410 ADTC | 1 |
| C510 AIR MOBILITY R&D LAB/FIO | 1 | E413 ESD | 2 |
| C513 PICATINNY ARSENAL | 1 | FTD | |
| C535 AVIATION SYS COMD | 1 | CCN | 1 |
| C557 USAIIC | 1 | ETID | 3 |
| C591 FSTC | 5 | NIA/PHS | 1 |
| C619 MIA REDSTONE | 1 | NICD | 5 |
| D008 NISC | 1 | | |
| H300 USAICE (USAREUR) | 1 | | |
| P005 ERDA | 1 | | |
| P055 CIA/CRS/ADD/SD | 1 | | |
| NAVORDSTA (50L) | 1 | | |
| NAVWPNSCEN (Code 121) | 1 | | |
| NASA/KSI | 1 | | |
|  | 1 | | |
| AFIT/LD | 1 | | |

NO
Preceding Page BLANK - FILM