

AD-A045 439

FOREIGN TECHNOLOGY DIV WRIGHT-PATTERSON AFB OHIO  
RADAR STATION P-35.(U)  
MAY 77

F/6 17/9

UNCLASSIFIED

FTD-ID(RS)T-0695-77

NL

| OF |  
AD  
A045439  
SIZE  
11



END  
DATE  
FILMED  
11 -77  
DDC

FTD-ID(RS)T-0695-77

①

AD-A045439

FOREIGN TECHNOLOGY DIVISION



RADAR STATION P-35

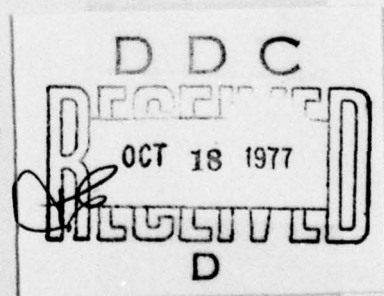

Approved for public release;  
distribution unlimited.



ACCESSION for	
NTIS	White Section <input checked="" type="checkbox"/>
DDC	Buff Section <input type="checkbox"/>
UNANNOUNCED	<input type="checkbox"/>
JUSTIFICATION	
BY	
DISTRIBUTION/AVAILABILITY CODES	
Dist.	AVAIL. and/or SPECIAL
<b>A</b>	

**FTD-** (RS)T-0695-77

## EDITED TRANSLATION

FTD-ID(RS)T-0695-77 26 May 1977

MICROFICHE NR: *FTD-77-C-000619*

RADAR STATION P-35

English pages: 13

Source: Voyenna Tekhnika, Number 8, August 1976,  
pp. 20-22

Country of origin: Bulgaria

Translated by: LINGUISTICS  
F33657-76-D-0389  
Michael J. Olivieri

Requester: FTD/ETWR  
Approved for public release;  
distribution unlimited.

THIS TRANSLATION IS A RENDITION OF THE ORIGINAL FOREIGN TEXT WITHOUT ANY ANALYTICAL OR EDITORIAL COMMENT. STATEMENTS OR THEORIES ADVOCATED OR IMPLIED ARE THOSE OF THE SOURCE AND DO NOT NECESSARILY REFLECT THE POSITION OR OPINION OF THE FOREIGN TECHNOLOGY DIVISION.

PREPARED BY:

TRANSLATION DIVISION  
FOREIGN TECHNOLOGY DIVISION  
WP-AFB, OHIO.

**FTD-** ID(RS)T-0695-77

Date 26 May 1977

RADAR STATION P-35

Radar Station or Radio-location Station (RLS) P-35 has a large tactical radius. It insures a circular scanning of the air space, detects the planes which are located in its operational zone and calculates their coordinates.

The station P-35 has the following basic tactical and technical characteristics: maximum range, depending on the type of plane and height of the flight-from 150 to 350 km. For example, the plane TU-104 which flies at an altitude of from 8,000 to 10,000 meters is detected at a distance of 350km; the scanning zone: in altitude-up to 25,000m, in angle of location-up to 30 degrees; errors while determining the coordinates: in distance plus or minus 500m, in azimuth plus or minus 0.5 degrees; partitioning ability: in distance-500m, in azimuth-1.5 degrees; time for one circular scanning of the space is 20 or ten seconds, in accordance with a speed of rotation of the antenna-3 or 6 turns per minute.

RLS P-35 has 6 channels. The 6 channels have frequencies in the centimeter range. Each channel has a separate sharply-directed antenna (seperate radiator). The antenna system is a type consisting of two parabolic reflectors measuring 9.7 x 3m, each set at a different height. Four radiators (for the 1st to 4th channels) are

attached to the lower reflector with the 5th and 6th attached to the upper reflector. The pattern of the antenna system is, on purpose, tight (about 1 degree) in the horizontal plane in order to achieve the necessary accuracy and partitioning ability by azimuth. The resulting pattern in the vertical plane is formed from the patterns of the 6 channels. It has a general width of 30 degrees (fig. 1.), which ensures the necessary scanning by angle of location. So that there are no gaps in the scanning zone, the neighboring patterns of the separate patterns are partially over-lapped. In the over-lapping sectors the signals of the several transmitters are radiated. In order to avoid the interference of these signals which can also lead to gaps in the zone of visibility, the six channels have different frequencies in the indicated range.

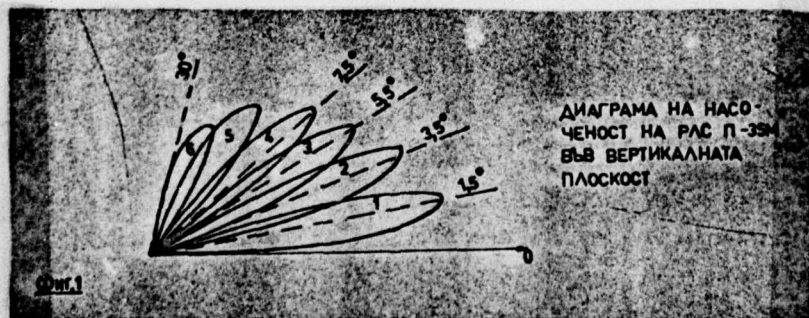

Fig. 1. Vertical Plane Beam Pattern of RLS P-35M

In essence the P-35 consists of a six one channel RLS constructively united in one unit. The high-frequency apparatus is inserted in the revolving, receiving-transmitting cabin (fig. 2.), to which are fastened the two reflectors. During the rotation of the cabin (and consequently also of the antennas) there occurs a circular scanning of space by azimuth. An electric motor, used to turn the cabin, consists of an electric engine and reduction gear with two rotation speeds of 3 and 6 turns per minute. There is a small tilt of the reflectors in vertical plane for altering the activity zone in known limits. This is accomplished in exceptional occasions and only for time, necessary for determining operational tasks for detecting and tracking individual planes. The antenna normally has to be found in a position which corresponds to the optimum angles of the maximums of the patterns in relation to the horizon.

The simplified structural diagram of RLS P-35 is shown in figure 3.

Figure 2.



ФИГ. 2.1 — индикаторна машина: 2 — шкаф за дистанционно управление на РЛС; 3 — шкаф на задаващите напрежения; 4 — индикатор азимут — разстояние (ИАР); 5 — индикатор за кръгов обзор (ИКО); 6 — кабелна кутия; 7 — блокове за захранване на ИКО; 8 — екран на електронно-лъчевата тръба; 9 — блок за развивка по разстояние; 10 — блок за задържане началото на развивката; 11 — входно табло с нуфи; 12 — блок на видео-сигналите; 13 — блок на сервоусилвателя; 14 — блок за управление на захранването; 15 — приемно-предавателна кабина; 16 — горен отражател; 17 — облъчвател на горната антена; 18 — долен отражател; 19 — облъчвател на долната антена.

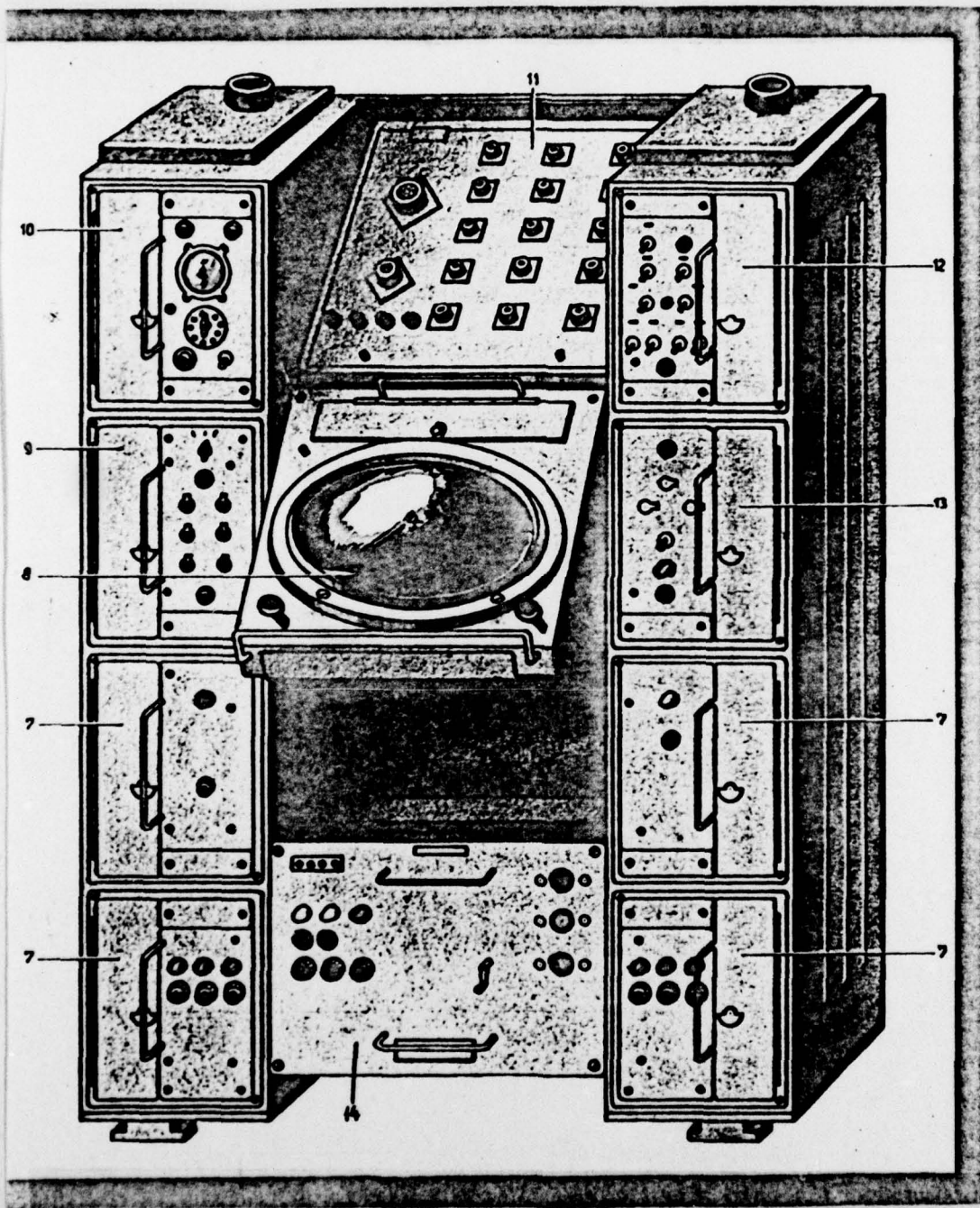

Figure 2.

- Fig. 2.
1. Indicator apparatus.
  2. Apparatus for distance control (RLS).
  3. Apparatus for instruction giving
  4. Azimuth indicator-distance (EAD).
  5. Indicator for circular scanning (EKO).
  6. Cabel box.
  7. Blocks for EKO feeding.
  8. Screen for the electronic radiation tube.
  9. Block for distance development.
  10. Block for arresting the start of development.
  11. Inlet board with sockets.
  12. Block for the video signals.
  13. Block for the amplification.
  14. Block for feeding control.
  15. Receiving-broadcasting cabin.
  16. Upper reflector.
  17. Upper reflector radiator.
  18. Lower reflector.
  19. Lower reflector radiator.

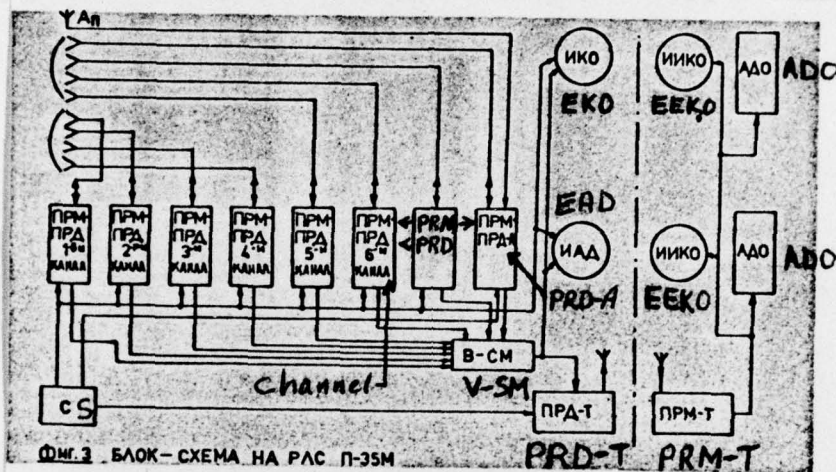

Fig. 3 Block diagram of RLS P-35M.

Material for the three figures taken from the publication "Transport", 1975 and from the magazine, "Military knowledge", Issue no. 4, 1976

Receiving and transmission abilities of the six channels in the centimeter range are equal. They are carried out by type ME-29 Magnetrons. All of these generate super-high frequency pulses with an output of 1MW, a duration of 2.7  $\mu$ s and a frequency of repetition of 37 $\frac{1}{2}$  Hz. All transmitters are activated simultaneously the moment releasing impulses enter from the synchronizer S in the station. The probing pulses which are generated in each channel enter the antenna, by means of the corresponding antenna switch on the wave leading track, from where they are radiated into space.

The reflected pulses from the target and other objects are received by the same antenna and again by means of the antenna switch (receiving regime) enter the receiver. So that every receiver works in its own frequency, it receives the reflected signals only on its own channel and is un-receptive to the signals of the other channels.

The receivers are filled with a super heterodyne system with UVCh oscillator . They have the system APCh for regulating the frequency of the super heterodyne and instantaneous and automatic regulating of the amplification for wrestling with the continuous and sustained pulse disturbances. After the amplification, transformation and detection, the reflected signals exit the

receiver and enter the video-mixer, by whose help they are united in one circuit connected with the station's indicators.

The indicator apparatus of RLS P-35 (fig. 2 and 3) includes two basic types of indicators: an indicator for circular scanning (EKO), an indicator for azimuth and distance (EAD), but also (EEKO) indicators for circular scanning which are situated in the command-control post.

EKO are filled with an electronic radiation tube, type 31LM32, set up with a turning, deflecting system. This type of indicator has 3 scales for distance: 100, 200 and 400km. The scaled grid consists of 10, 50 and 100 kilometer divisions according to distance and of 5 and 30 degree divisions according to azimuth. EKO works in three orders-circular, sector and annular scanning. In the sector scanning the beginning of the development may be removed from the center at every spot of the screen and even outside its boundaries. During an annular sweep the start of the development is detained with respect to the sounding probe for time which conforms to distance in space from 40 to 350<sub>4</sub> km (unsteady at 10 km.).

EAD serves for a more exact fixing of the coordinates

of the targets and for an enhancement of the partitive ability in a randomly chosen sector. The coordinates are fixed in a rectangular co-ordinated system (the azimuth by horizontal axis, but the distance by vertical axis). The sector of observation has a width from 20 to 60 degrees, but the beginning of the development can be regulated from 40 to 350 km by 10~~0~~ km. The scales according to distance are 30, 50 and 150~~0~~ km. 2, 10, 50 and 100 kilometric divisions are used for distance of 1, 5 and 30 degrees in azimuth.

The radar information is delivered to EEKO with the help of a rebroadcasting line, which includes a transmitting (PRD-T) and receiving system (PRM-T). The transmitting system is placed along with the RLS. This assures transmission of the reflected radar video signals, switching signals, signals for rotation (azimuth position) of the antenna, impulses for scaled division according to distance and azimuth. All these signals enter PRD-T from RLS, where they are coded, transformed into high frequencies and radiated into space with the help of an antenna.

The receiving system PRM-T is deployed together with EEKO. It receives the signals which are passed on by the rebroadcasting line, strengthens them, transforms them into video impulses and brings about the decoding and separating of the signals. The switching signals, signals

for rotation (angular position) of the antenna and radar signals together with the impulses for the scaled division for distance and azimuth are dismantled separately after exiting the receiving system.

The switching signals enter the generator for spreading out to EEKO, signals for annular position enter the reduction system of the electronic radiation tube, but the radar signals and scaled divisions for azimuth and distance enter the governing electrode of the tube.

The rebroadcasting system enables information distances from 20 to 28~~0~~km, during direct visibility, to be passed on. For small distances (to 50~~0~~km) between RLS and EEKO, the rebroadcasting system can use cables over which the indicated signals of radio frequency are passed on.

EEKO, like EKO, has distance scales of 100, 200 and 400km. The coordinates of the planes are fixed on an electrical~~al~~ scaled screen with the help of 10 and 50 kilometric divisions and 5 and 30 degree divisions for azimuth.

Besides the above examined system, P-35 has the apparatus of a secondary radar system with operational response. This apparatus works jointly with the plane's

answering system SOM-64 and assures the interrogation of the plane's system, the receiving of the responding signals and their processing and portraying.

The ground apparatus of the system with operational answer consists of a receiver-transmitter (PRM-PRD-A), an apparatus for decoding and processing (ADO), a main antenna for interrogating, an antenna for passing the collateral pages to the main antenna, and an apparatus for portraying which includes two numerical boards and system for control.

The receiving-transmitting apparatus is mounted in the rotating cabin of the RLS, but the apparatus for decoding, processing and portraying is located in close proximity to the indicator apparatus of the station. The antenna for interrogation is shaped like a radiator and works jointly with the upper reflector of the P-35M radar antenna. The antenna for feeding is comprised of a vertical series undirected in a horizontal plane, vibrates and also is assembled at the end of the reflector.

Signals are received from the responding system of one's own planes with the help of the apparatus for operational answer, by which can be determined their coordinates and also to receive additional information-the number of the plane, height of the flight and fuel supply. The

signals from the responding system are depicted on the indicators of the circular scan. The additional information for number, height of flight and fuel supply are indicated on the numerical board.

The apparatus for radar beacon system serves as a means of identifying the planes and determining their location by EKO, for portraying of additional information for a given plane on the numerical board, for automatic and continuous renewal of the information and automatic tracking of the selected plane. The considerable possibilities of the RLS P-35M for detecting and tracking one's own planes are increased with the use of this system.

UNCLASSIFIED

SECURITY CLASSIFICATION OF THIS PAGE (When Data Entered)

REPORT DOCUMENTATION PAGE		READ INSTRUCTIONS BEFORE COMPLETING FORM
1. REPORT NUMBER FTD-ID(RS)T-0695-77	2. GOVT ACCESSION NO.	3. RECIPIENT'S CATALOG NUMBER
4. TITLE (and Subtitle) RADAR STATION P-35	5. TYPE OF REPORT & PERIOD COVERED Translation	
	6. PERFORMING ORG. REPORT NUMBER	
7. AUTHOR(s)	8. CONTRACT OR GRANT NUMBER(s)	
9. PERFORMING ORGANIZATION NAME AND ADDRESS Foreign Technology Division Air Force Systems Command United States Air Force	10. PROGRAM ELEMENT, PROJECT, TASK AREA & WORK UNIT NUMBERS	
11. CONTROLLING OFFICE NAME AND ADDRESS	12. REPORT DATE August 1976	
	13. NUMBER OF PAGES 13	
14. MONITORING AGENCY NAME & ADDRESS (if different from Controlling Office)	15. SECURITY CLASS. (of this report) UNCLASSIFIED	
	15a. DECLASSIFICATION/DOWNGRADING SCHEDULE	
16. DISTRIBUTION STATEMENT (of this Report) Approved for public release; distribution unlimited.		
17. DISTRIBUTION STATEMENT (of the abstract entered in Block 20, if different from Report)		
18. SUPPLEMENTARY NOTES		
19. KEY WORDS (Continue on reverse side if necessary and identify by block number)		
20. ABSTRACT (Continue on reverse side if necessary and identify by block number) 17		

DISTRIBUTION LIST

DISTRIBUTION DIRECT TO RECIPIENT

ORGANIZATION	MICROFICHE	ORGANIZATION	MICROFICHE
A205 DMATC	1	E053 AF/INAKA	1
A210 DMAAC	2	E017 AF/RDXTR-W	1
B344 DIA/RDS-3C	8	E404 AEDC	1
C043 USAMIA	1	E408 AFWL	1
C509 BALLISTIC RES LABS	1	E410 ADTC	1
C510 AIR MOBILITY R&D LAB/FIO	1	E413 ESD	2
C513 PICATINNY ARSENAL	1	FTD	
C535 AVIATION SYS COMD	1	CCN	1
C557 USAIC	1	ETID	3
C591 FSTC	5	NIA/PHS	1
C619 MIA REDSTONE	1	NICD	5
D008 NISC	1		
H300 USAICE (USAREUR)	1		
P005 ERDA	1		
P055 CIA/CRS/ADD/SD	1		
NAVORDSTA (50L)	1		
NAVWPNSCEN (Code 121)	1		
NASA/KSI	1		
AFIT/LD	1		