

AD-A045 701

AIR FORCE FLIGHT DYNAMICS LAB WRIGHT-PATTERSON AFB OHIO F/G 1/3
STRUCTURAL ANALYSIS OF A VANE FOR AN ADVANCED ENVIRONMENTAL CON--ETC(U)
JUN 77 K P SCHWARTZ
AFFDL-TR-77-49

UNCLASSIFIED

NL

1 OF 2
ADA
045701



AD A 045701

AFFDL-TR-77-49

Handwritten signature and a circled number '2'.

**STRUCTURAL ANALYSIS OF A VANE FOR AN
ADVANCED ENVIRONMENTAL CONTROL SYSTEM
ROTARY VANED COMPRESSOR**

*KENNETH P. SCHWARTZ
MECHANICAL BRANCH
VEHICLE EQUIPMENT DIVISION*

JUNE 1977

TECHNICAL REPORT AFFDL-TR-77-49
Final Report for Period February 1976 to February 1977

AD NO. _____
DDC FILE COPY

Approved for public release; distribution unlimited.

AIR FORCE FLIGHT DYNAMICS LABORATORY
AIR FORCE WRIGHT AERONAUTICAL LABORATORIES
AIR FORCE SYSTEMS COMMAND
WRIGHT-PATTERSON AIR FORCE BASE, OHIO 45433

DDC
RECEIVED
OCT 21 1977
B

NOTICE

When Government drawings, specifications, or other data are used for any purpose other than in connection with a definitely related Government procurement operation, the United States Government thereby incurs no responsibility nor any obligation whatsoever; and the fact that the government may have formulated, furnished, or in any way supplied the said drawings, specifications, or other data, is not to be regarded by implication or otherwise as in any manner licensing the holder or any other person or corporation, or conveying any rights or permission to manufacture, use, or sell any patented invention that may in any way be related thereto.

This report has been reviewed by the Information Office (OI) and is releasable to the National Technical Information Service (NTIS). At NTIS, it will be available to the general public, including foreign nations.

This technical report has been reviewed and is approved for publication.

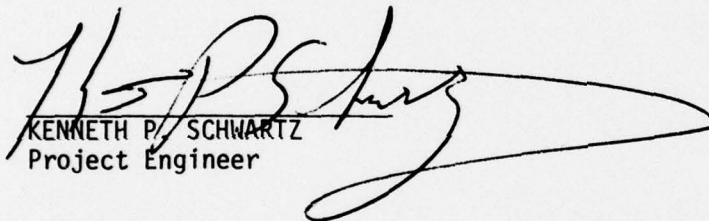
KENNETH P. SCHWARTZ
Project Engineer

FOR THE COMMANDER:

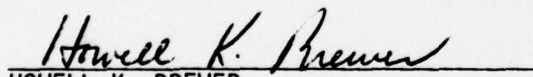
HOWELL K. BREWER
Chief, Mechanical Branch
Vehicle Equipment Division
Air Force Flight Dynamics Laboratory

"If your address has changed, if you wish to be removed from our mailing list, or if the addressee is no longer employed by your organization please notify _____, W-PAFB, OH 45433 to help us maintain a current mailing list".

Copies of this report should not be returned unless return is required by security considerations, contractual obligations, or notice on a specific document.

UNCLASSIFIED

SECURITY CLASSIFICATION OF THIS PAGE (When Data Entered)

REPORT DOCUMENTATION PAGE		READ INSTRUCTIONS BEFORE COMPLETING FORM
1. REPORT NUMBER AFFDL-TR-77-49	2. GOVT ACCESSION NO.	3. RECIPIENT'S CATALOG NUMBER
4. TITLE (and Subtitle) STRUCTURAL ANALYSIS OF A VANE FOR AN ADVANCED ENVIRONMENTAL CONTROL SYSTEM ROTARY VANED COMPRESSOR.	5. TYPE OF REPORT & PERIOD COVERED Final Report for Period February 1976 - February 1977	6. PERFORMING ORG. REPORT NUMBER
7. AUTHOR(s) Kenneth P. Schwartz	8. CONTRACT OR GRANT NUMBER(s) O2201F	
9. PERFORMING ORGANIZATION NAME AND ADDRESS Air Force Flight Dynamics Laboratory (AFFDL/FEM) Air Force Systems Command Wright-Patterson Air Force Base, Ohio 45433	10. PROGRAM ELEMENT, PROJECT, TASK AREA & WORK UNIT NUMBERS 6146 17 92 25	
11. CONTROLLING OFFICE NAME AND ADDRESS	12. REPORT DATE June 1977	
14. MONITORING AGENCY NAME & ADDRESS (if different from Controlling Office) 12 174p.	13. NUMBER OF PAGES 176	15. SECURITY CLASS. (of this report) Unclassified
16. DISTRIBUTION STATEMENT (of this Report) Approved for public release; distribution unlimited		15a. DECLASSIFICATION/DOWNGRADING SCHEDULE
17. DISTRIBUTION STATEMENT (of the abstract entered in Block 20, if different)		<div style="border: 2px solid black; padding: 5px; text-align: center;"> <p>DDC</p> <p>RECEIVED</p> <p>OCT 21 1977</p> <p>RECEIVED</p> <p>B</p> </div>
18. SUPPLEMENTARY NOTES		
19. KEY WORDS (Continue on reverse side if necessary and identify by block number)		
Advanced composites	NASTRAN	Coolers
Graphite	Computer-aided design	Air conditioning
Compressors	Bearings	Materials
Vanes	Lubrication	
Structural analysis	Environmental control	
20. ABSTRACT (Continue on reverse side if necessary and identify by block number)		
<p>The primary intent of this effort was to determine if the existing ROVAC vane could be improved from a total weight, operational bearing loads, and vane tip deflection point of view. To attain these improvements the use of advanced filamentary composite materials was suggested and was then analyzed in detail. <i>Studied</i></p>		

012070 ✓

LB

UNCLASSIFIED

SECURITY CLASSIFICATION OF THIS PAGE(When Data Entered)

The analysis conducted consisted of the generating of an automated vane modeling (AVM) computer program from which a NASTRAN finite element model of the ROVAC vane could be modeled. Through the use of the AVM program, then, 22 design variations and materials substitutions were set up and analyzed by means of NASTRAN. Specifically the analysis involved 10 runs in which 9 advanced composite layups were compared against the baseline ROVAC vane. Following this survey the ROVAC vane axles (FDL-1 design) and vane axles and boots (FDL-2 design) were removed for further design improvements. Overall, the results of the study were very positive. Bearing loads were reduced from 975 lbs to 801 and 676 lbs for the FDL-1 and FDL-2 designs, respectively. They were then further reduced to 328 lbs by thinning the vane down to 40% of its original thickness. For these same design changes, vane-tip deflections were reduced from 2.91 mils to 1.11 and 1.06 mils for the FDL-1 and FDL-2 carbon graphite designs, respectively. They were further reduced to .9 mils for the 40% thick design. In regard to actual vane weight the following improvements were noted: Basic ROVAC Vane = .942 lbs, FDL-1 = .772 lbs, FDL-2 = .608 lbs, and the FDL-2 (40% thick) = .323 lbs. In addition to the above, overall vane stresses were also reduced by 40% to 60% and vane-edge deflections were reduced by 70%.

ACCESSION for	
NTIS	Write Section <input checked="" type="checkbox"/>
DDC	Diff Section <input type="checkbox"/>
UNANNOUNCED	<input type="checkbox"/>
JUSTIFIED	<input type="checkbox"/>
BY	
DISTRIBUTION/AVAILABILITY	
Dist. APR 81 201 31	
A	23

O.S.

UNCLASSIFIED

SECURITY CLASSIFICATION OF

(Data Entered)

FOREWORD

The analysis conducted in this report was performed in-house by the Mechanical Branch, Vehicle Equipment Division, of the Air Force Flight Dynamics Laboratory. The effort is part of an FEM Support program (to FEE) to obtain increased capacities, and performance improvements in the area of aircraft environmental control systems. This effort was performed under Project 61460225, currently under the FEE thermal control group. The analysis was conducted from February 1976 to February 1977 by Kenneth P. Schwartz of the Air Force Flight Dynamics Laboratory (AFFDL/FEM).

Special acknowledgment goes to Mrs. S. Foley (4950/ADDP) for her timely programming assistance in this effort.

This report was submitted by the author in March 1977.

TABLE OF CONTENTS

SECTION	PAGE
I INTRODUCTION	1
II NASTRAN MODELING PROGRAM	9
1. Basic Model	10
2. "GRID" Data Set	10
3. "CQUAD2" Data Set	13
4. Property Identification Determination (PID)	13
5. Theta Determination (TH)	14
6. "CBAR" Data Set (Edge Option)	16
7. Double, Single, or Partial Axle Option (PID Determination)	18
8. "CBAR" Data Set (Non-Edge Option)	19
9. "SPC" Data Set (Mathematical Constraints)	21
a. Symmetry Condition	21
b. Unidirectional Bearing Constraint	23
c. Reaction Points	23
d. Z Axis Moment Constraint (M_z)	23
e. Combined Constraints	23
10. Property and Materials Data Sets	24
a. "PQUAD2" Data	24
b. "PBAR" Data	25
c. "MAT1" Data	26
11. ROVAC Vane Loading	26
a. Rotational Force ("RFORCE")	26
b. Inertia Loading ("GRAV")	27
c. Gravity Vector (Item No. 4)	28
d. Combined Loads	29
e. Parameter Usage ("WTMASS" "GRDPNT")	30
f. Rotational Axis Definition	30
g. Program Termination	31

TABLE OF CONTENTS (CONT'D)

SECTION	PAGE	
III	AVM PROGRAM INPUT AND OPERATION	32
	a. Input Subscripts	32
	b. Computed Variables	33
	c. Program Input	35
	d. Data Summary	39
	e. Test Cases	39
	f. Program Input/Output	39
IV	VANE ANALYSIS SETUP	43
	1. Part I (ROVAC and Advanced Composites)	43
	a. Basepoint Analysis (ROVAC, Case No. 10)	44
	b. Advanced Composites Analysis	45
	(1) "MAT2" NASTRAN Input	47
	(a) Analysis Case (MAT2 Input)	48
	(b) Orthogonal Case (Case No. 2)	50
	(2) "MAT2" Input Summary (Cases No. 1 & No. 2)	51
	(3) "MAT2" Input Summary (Cases 1 through 10)	52
	(a) Analysis Cases No. 9 and No. 10	56
	(b) Analysis MAT2 Input Summary for Cases 1 through 10	56
	2. Part II (Elimination of Axles and Boots)	56
	a. Axle Removal	58
	b. Boot Removal	58
	3. Part III (Vane Thickness Variations) FDL-2-.xt	58
	4. Part I, II, III Summary	58
V	VANE ANALYSIS	62
	1. Part I, Analysis and Discussion	64
	2. Part II, Analysis and Discussion	70
	3. Part III, Analysis	74

TABLE OF CONTENTS (CONCLUDED)

SECTION		PAGE
VI	CONCLUSIONS AND RECOMMENDATIONS	78
	1. Conclusions	78
	2. Recommendations	79
	a. Materials Considerations	79
	b. Analysis Verification	80
	c. Design Variations	81
	d. Refined Analysis	81
	e. Margin of Safety (MOS) Study Recommendation	81
APPENDIX		
A	Program Vane Listing in AVM Fortran Code	83
B	Test Case Plots and Abbreviated Listings for Test Cases 1 through 4	93
C	NASTRAN Program Listings From a Sorted Input	117
D	Vane Deflected Shapes For 22 Analysis Cases	143
REFERENCES		166

LIST OF ILLUSTRATIONS

FIGURE		PAGE
1	Schematic of ROVAC Machine	2
2	Assembly Schematic of ROVAC Machine	3
3	ROVAC Vane Loading and Deflections	5
4	ROVAC Test Vane (Design and Assembly)	6
5	ROVAC Vane Photo	7
6	Basic AVM Nodal Arrangement	11
7	AVM Model Element Idealization	12
8	AVM Model Property Identification	15
9	AVM Model Theta Relationship	15
10	Segregated AVM Bar Elements For Double Axle	17
11	AVM Bar Elements Within Total Model	17
12	Non-Edge, Single Axle Model	20
13	AVM Symmetrical SPC Set Definition	22
14	Vane and Axle Area Definition	34
15	Tabulated Deflections, Positions A Through E	65

LIST OF TABLES

TABLE		PAGE
1	"CBAR" Output for Figures 10 and 11	19
2	AVM Generated Constraint Set	25
3	AVM Input Data Summary	40
4	Input Data for AVM Test Cases 1, 2, and 3	41
5	Baseline Comparison Summary	45
6	Associated Filament Laminate Properties	46
7	"MAT2" Summary Cases No. 1 and No. 2	51
8	SQ5 Properties for 40/60 Steel Composite Boot Area, Using 5 Different Composite Inserts	52
9	"MAT2" Input G Value and Associated Equations ($\times 10^6$)	53
10	Summarized MAT2 Values for Vane Area No. 2	54
11	Vane Areas No. 3 and No. 4 "MAT2" Data Input	55
12	NASTRAN Input Summary For Analysis Cases No. 1 through No. 10	57
13	Actual NASTRAN Input Changes for Cases 1 through 10	59
14	Summary of All Cases and Design Variations Analyzed	63
15	Load/Deflection Summary (Analysis Cases No. 1 Through 10)	66
16	Maximum Principal Stress Summary Reflecting the Top Ten Stress Values	67
17	Composite Region Stress Summary for Analysis Cases 1 through 10	68
18	Load/Deflection Changes Due to Vane Redesign	71
19	Element Numbers Denoting the Ten Highest Maximum Principal Stress Values for Each Analysis Case	72
20	Maximum Principal Stress Summary For Vane Redesign	73
21	Load/Deflection Changes Due to Vane Resizing (Material = 0 Deg. = 3, +45, -45, 90 Deg.)	75
22	Load/Deflection Changes Due to Vane Resizing (Material = Chopped Graphite)	75
23	Maximum Principal Stress Summary For Changes Due to Vane Resizing (Ten Highest Values) Material = 0 Deg. = 3, +45, -45, 90 Deg.)	76
24	Maximum Principal Stress Summary For Changes Due to Resizing (Material = Chopped Graphite)	76

SECTION I
INTRODUCTION

For some time now, the AFFDL has been investigating the use of rotary-vaned positive-displacement air-cycle machines for aircraft environmental control systems. The selection of a rotary-vaned unit is based on the assumption that a positive displacement unit of this type is capable of operating more efficiently than conventional turbo-machinery at the low flow rates required to cool distributed small heat loads.

Preliminary rotary cooler studies were undertaken with two major objectives in mind: (1) to identify the most promising combination of rotary machine and equipment arrangement for meeting the cooler requirements, and (2) to identify any significant problem areas and possible solution approaches.

Two types of rotary positive-displacement machinery were considered during previous investigations; they were the single-rotor sliding-vane type of machine, and the two-rotor fixed-vane machine. Although there are a number of different machinery designs which use the basic sliding-vane principle, only one design configuration (herein referred to as the ROVAC machine) was considered for the rotary cooler application. Likewise, only one configuration of the two-rotor fixed-vane machine was considered. These two machines had considerably different mechanical features and thus provided a reasonable basis for initial assessment of machinery viability for the rotary cooler application.

Ultimately, a sliding-vane or ROVAC machine was selected. Schematic drawings of the ROVAC sliding-vane machine are shown in Figures 1 and 2. The machine consists of a circular slotted rotor, concentrically positioned in the elliptical bore of a stationary housing. Sliding vanes in the rotor slots divide the space between rotor OD and housing bore into a number of small spaces (cylinders) whose volumes vary as the rotor turns. On one side of the bore's minor axis these variable volumes are used to accomplish positive displacement compression; on

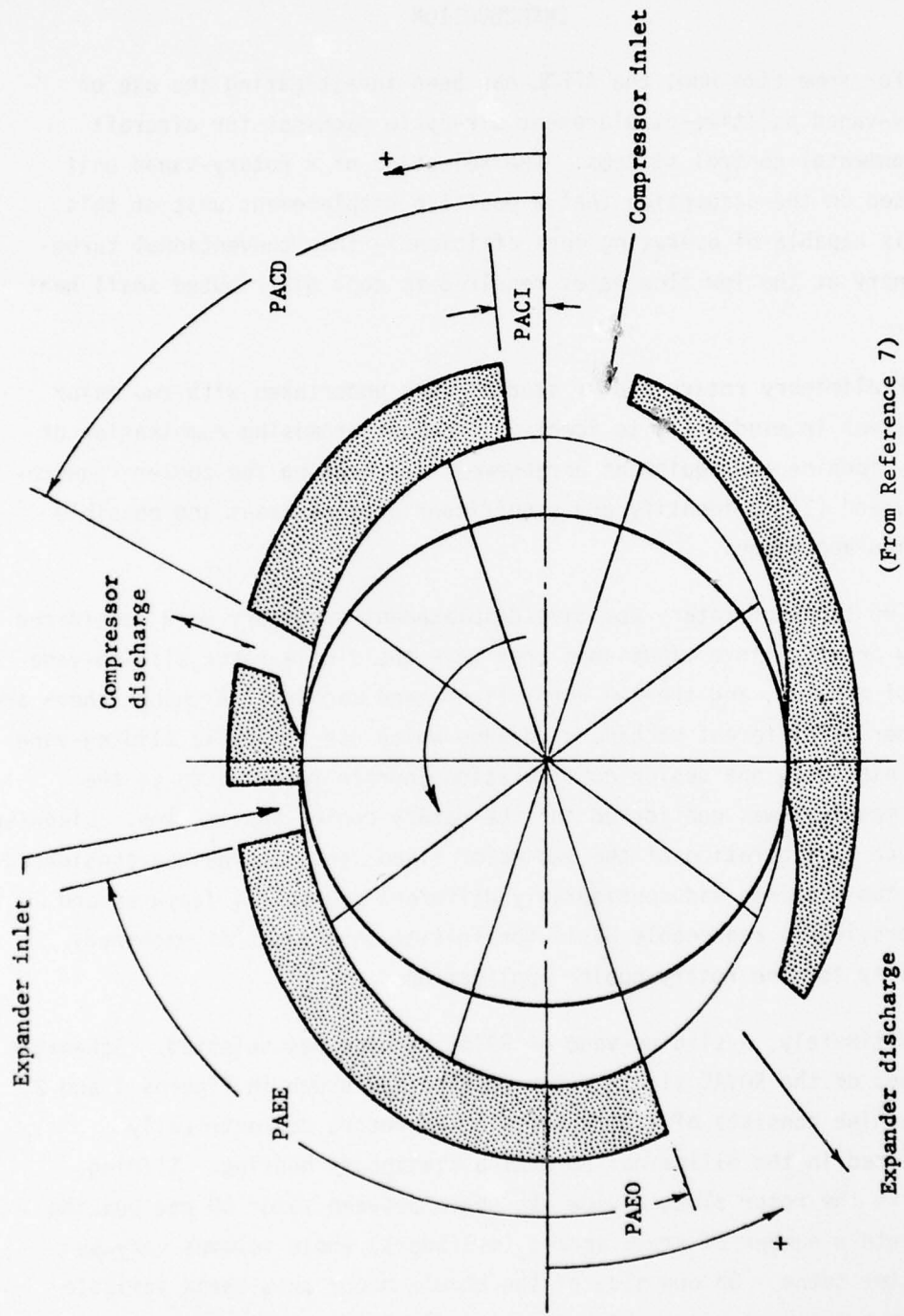

(From Reference 7)

Figure 1. Schematic of ROVAC Machine

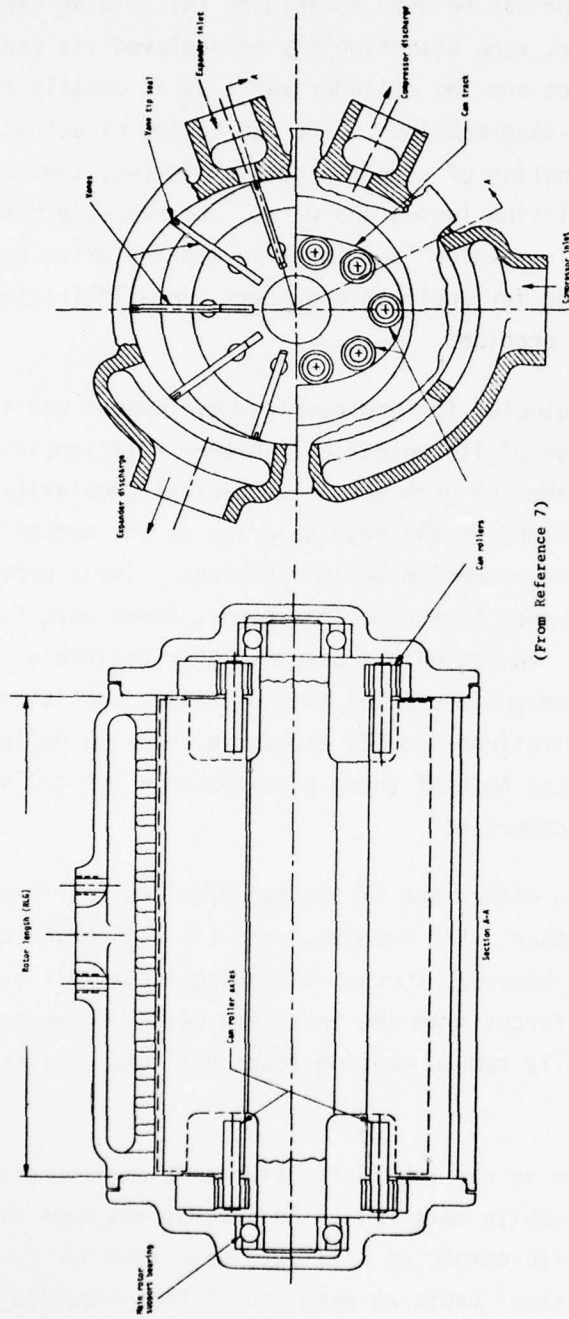

(From Reference 7)

Figure 2. Assembly Schematic of ROVAC Machine

the other side of the minor axis the variable volumes perform positive displacement expansion. As depicted in Figure 2, cams and cam rollers at the two ends of the rotor can be used to actuate the sliding vanes within the rotor slots. Or, vane actuation may be achieved via contact forces between the vane tips and the cylinder wall, as is usually the case in commercial sliding-vane machines. The cam method of actuation permits reduction or elimination of vane-tip contact forces, thus reducing or eliminating vane-tip friction losses and wear. The vane-tip method of actuation is mechanically simpler (and lower in manufacturing cost) and will usually be selected for applications where vane-tip friction and wear do not present severe problems.

The ultimate method selected for engineering development was the cam actuation method because of its potentially higher efficiencies. However, this method has inherent problems in mechanical complexity. Within the engineering development the true severity of the mechanical problems associated with cam actuation became apparent. These problems are especially true at the even higher design speeds, where payoffs in increased efficiencies and reduced weight become highly desirable. Basically, two distinct problems presented themselves and consisted of: (1) bearing load/speed limitations and (2) excessive vane-tip deflection values. Figure 3 illustrates both of these problems on a typical vane for use in a cam-actuated compressor.

The normal solution to either one of the two problems inherently leads to compounding the other. For example, vane-tip deflection can be reduced via heavier vanes; however, increased bearing loads will occur due to higher centrifugal forces from the increased mass. Conversely, reduced vane masses generally reduce bearing loads but lead to increased tip deflections.

One potential solution to the load/deflection problem is the use of advanced low-density graphite materials. An attempt was made at this through the use of a graphite-compacted material, held together by means of two axles and a set of steel boots at each end of the composite structure. Figures 4 and 5 illustrate this concept, which was eventually fabricated and tested.

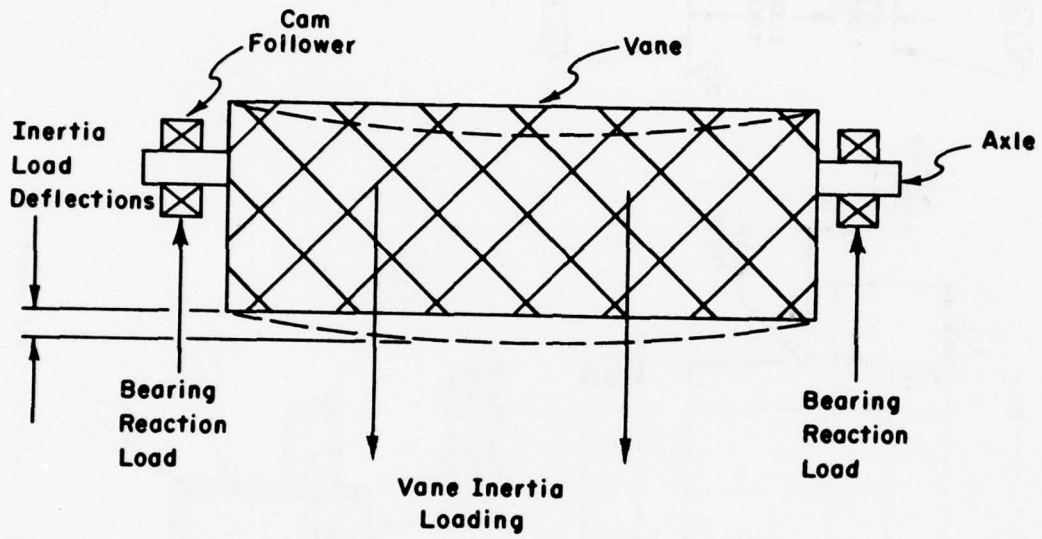

Figure 3. ROVAC Vane Loading and Deflections

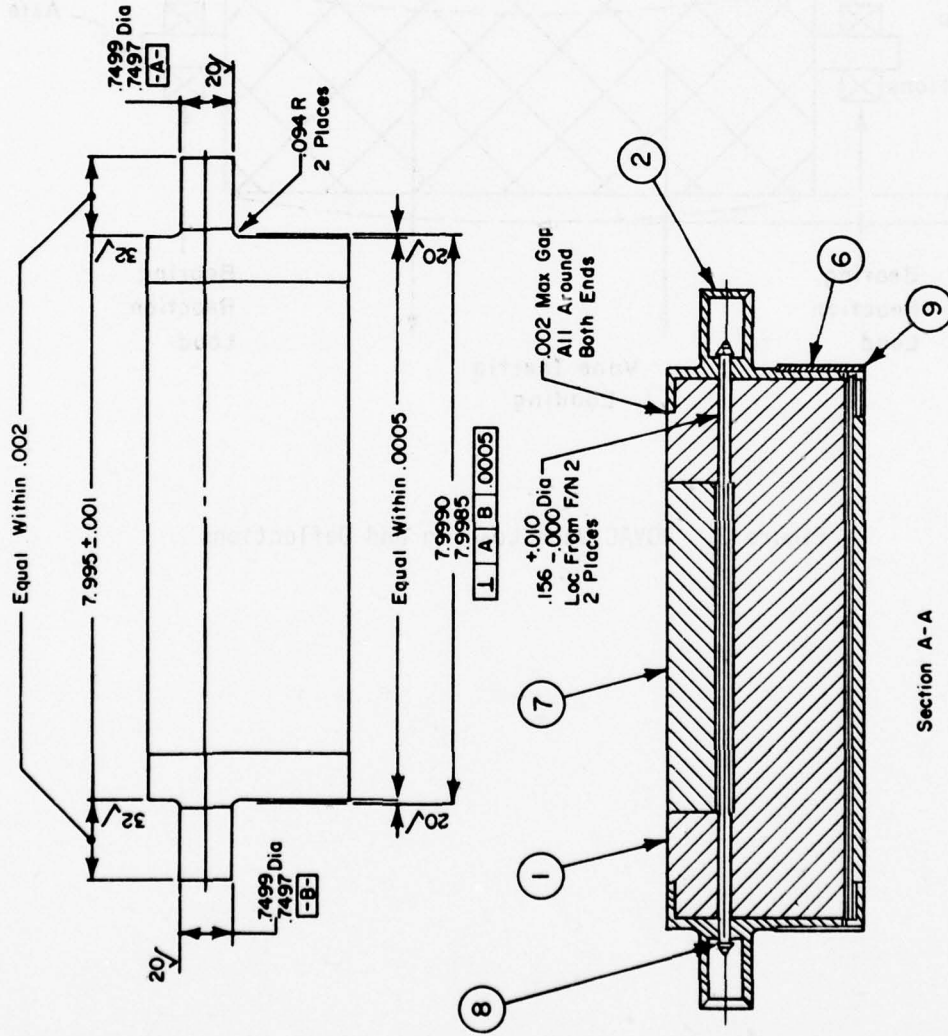
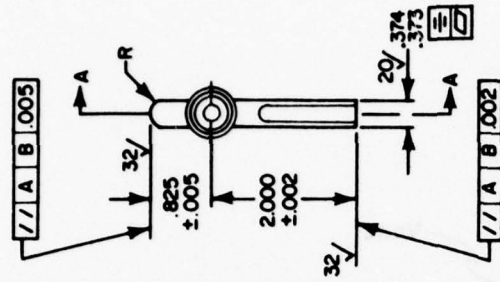

Figure 4. ROVAC Test Vane (Design and Assembly)

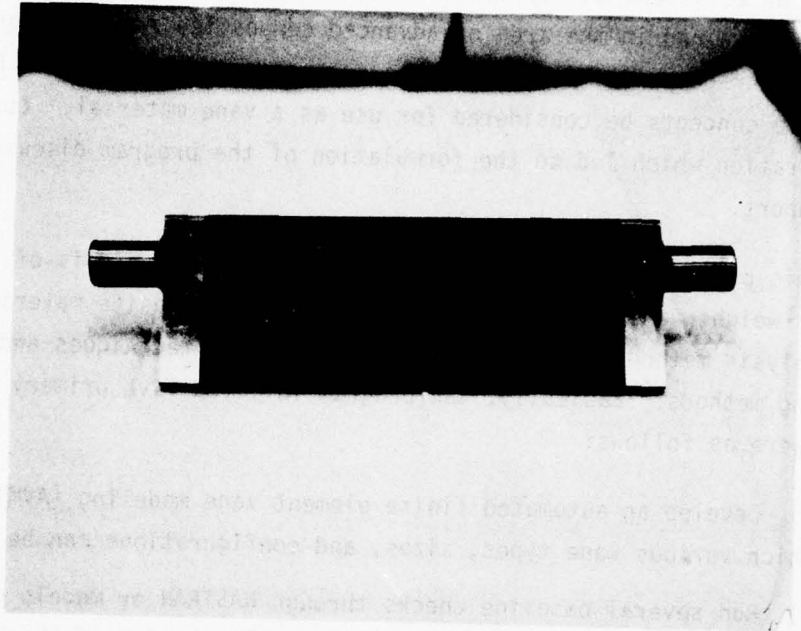

Figure 5. ROVAC Vane Photo

Although the above concept did offer some improvement, load/deflection problems were still prevalent and were severely inhibiting the development of an efficient air-cycle machine. Based on similar problems and experience gained in the area of advanced composites for bearings and landing-gear-component design, it was suggested that advanced filamentary composite concepts be considered for use as a vane material. It is this consideration which led to the formulation of the program discussed within this report.

This program is directed toward the design and analysis of various lighter weight vane concepts employing advanced composite materials. The analysis methods used employed finite element techniques and refined modeling methods. Basically, the program involved five primary objectives which were as follows:

- A) Develop an automated finite element vane modeling (AVM) program from which various vane types, sizes, and configurations can be modeled.
- B) Run several baseline checks through NASTRAN or models generated by means of the AVM program. These models will consist of the base graphite-compact vane (Figures 4 and 5) to which analysis results can be compared to available analytical and experimental results on the vane itself.
- C) Run eight direct composite-substitution analysis surveys to determine the effects of using advanced composites within the vane in its current design state.
- D) Run several additional composite runs beyond the current design state whereby the negative effects of incorporating steel boots and axles might be eliminated.
- E) Based on the results of C and D above, conduct a series of runs incorporating vane thickness variations on the two most promising designs.

SECTION II

NASTRAN MODELING PROGRAM

Based on previous efforts in the area, the requirement for some form of automated data generator became quite obvious. Two primary reasons existed which determined this requirement and the approach to be selected for the automated data-generation system. The first was the fact that the sizing of the air-cycle machine itself involves developmental changes along with changes in vane dimensions and sizes. As a result, by the time one vane could be set up manually, the data itself became obsolete. The second and most important reason was the fact that, through a manual mode of data generation, little other than design verification studies could be made within the time frames involved. Studies of this type were very beneficial but what was really required were parametric analysis surveys where design changes could be studied and actually implemented.

The actual parametric data-generation system, herein referred to as the AVM (Automated Vane Modeling) program, employed in this effort involves a total of eight parameters which can be varied in the automated mode. These are as follows:

1. The ability to responsively change the basic dimensions of the vane itself.
2. The ability to vary the level of detail of the analysis effort (course versus refined finite-element models).
3. The ability to incorporate materials changes for the basic vane itself.
4. The ability to introduce materials variations (multi-materials) within the design of a single vane.
5. The ability to include the use of advanced composites for reductions in vane weight.
6. The ability to vary the method of bearing attachment to the vane.

7. The ability to vary the method of load transmission through the vane by either double axles, a single axle, or only a partial axle.
8. The ability to automatically include and vary all of the symmetric boundary constraints, rotational force vectors, panel inertia variables, and vane loading and reaction boundary conditions.

1. BASIC MODEL

The AVM program developed for this effort consists of generating the required NASTRAN input for seven basic data sets. Specifically, these include the "GRID" set, "CQUAD2" set, "SPC1" and "SPCADD" set involving both "RFORCE" (rotational forces), "GRAV" (Inertia forces) and miscellaneous external forces to the vane.

The basic model itself consists of a rectangular area (Figure 6) divided into a set of NPX (x projection) and NPY (y projection) lines. Typically, this results in a model involving a total of (NPX) (NPY) nodes in the structural analysis model.

To meet the eight requirements of the study, the uniform distribution noted in Figure 6 was further developed to a point where the actual x and y values for each x or y projection are individually input. A typical resulting model based on this setup is further illustrated in Figure 7 along with the element idealization.

2. "GRID" DATA SET

In accordance with the required NASTRAN input format, the following data is included for each grid point within the model.

ITEM NO.	1	2	3	4	5	6	7	8
COC. LOC.	1-8	9-16	17-24	25-32	33-40	41-48	49-56	57-64
VARIABLE	GRID	ID	CP	x	y	z	CD	PS

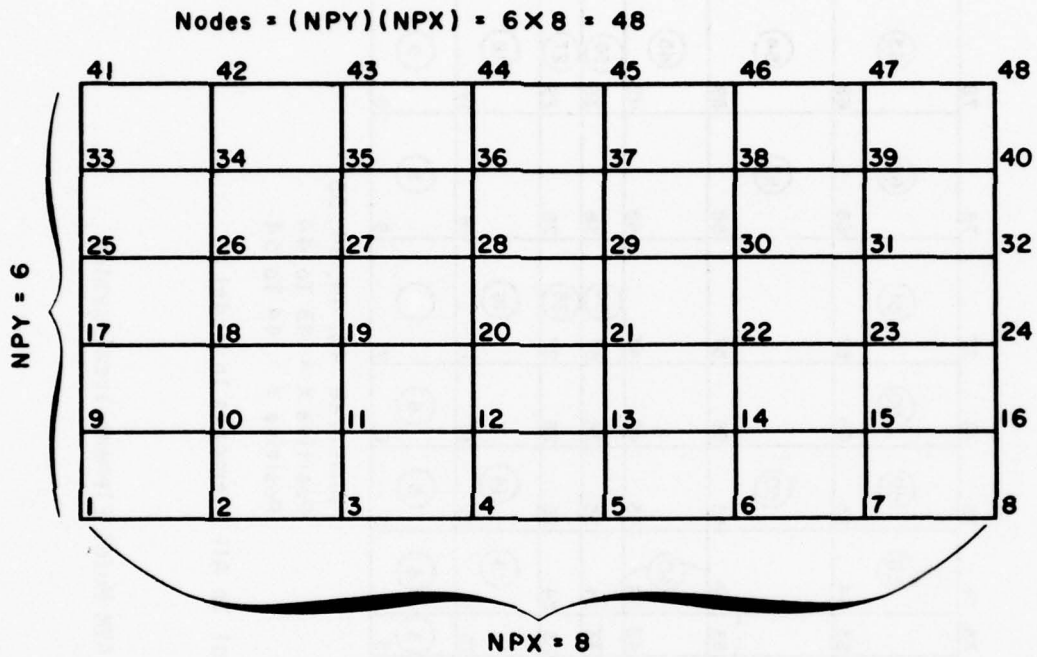

Figure 6. Basic AVM Nodal Arrangement

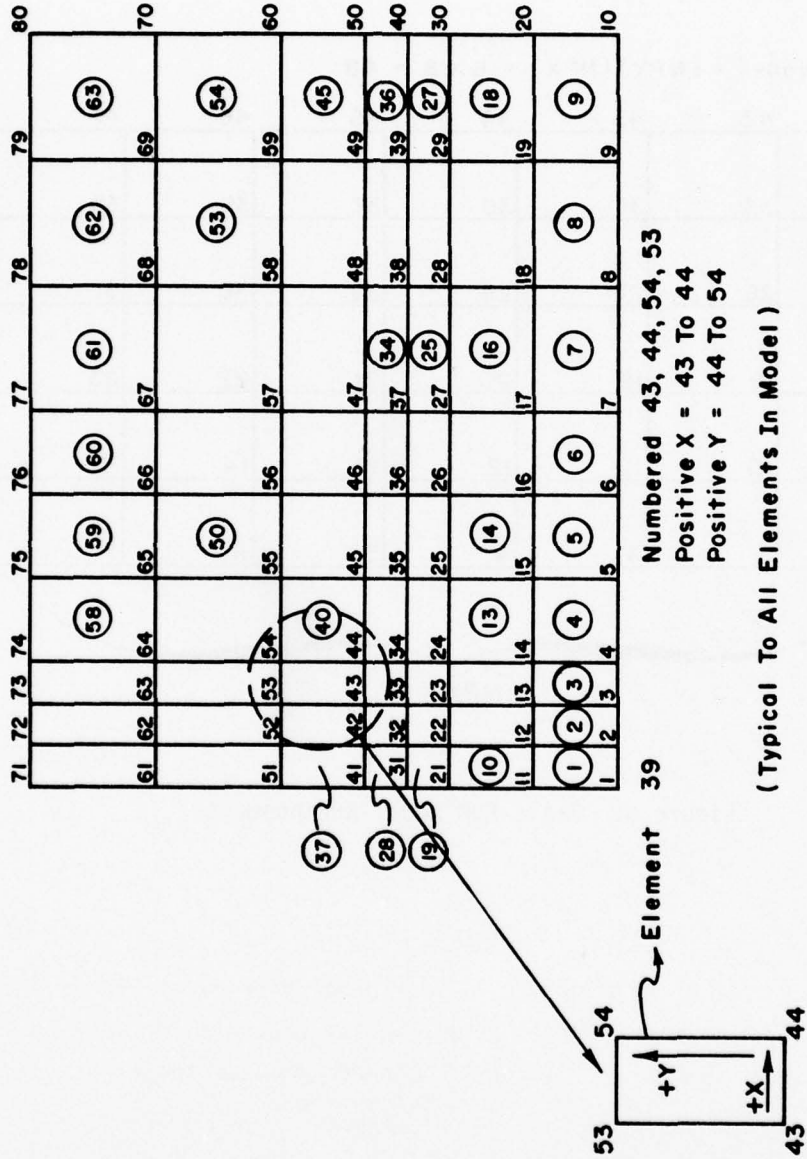

Figure 7. AVM Model Element Idealization

- Item 1 - Alpha Name Grid
- Item 2 - Grid Point Number (integer)
- Item 3 - Blank (for ROVAC case)
- Item 4 } x, y, z values for Node Point
- Item 5 } (Floating Point)
- Item 6 }
- Item 7 } Blank Fields (for ROVAC case)
- Item 8 }

3. "CQUAD2" DATA SET

It is within the "CQUAD2" set where the material properties, property variations (multi-materials per vane), and the use of advanced composites are introduced into the vane model. Specifically, these parameters are noted as variables PID and TH on the following NASTRAN data set.

ITEM NO.	1	2	3	4	5	6	7	8
COL. LOC.	1-8	9-16	17-24	25-32	33-40	41-48	49-56	57-64
VARIABLE	CQUAD2	EID	PID	G1	G2	G3	G4	TH

- Item 1 - Alphanumeric name "CQUAD2"
- Item 2 - Element identification no. (EID) (integer)
- Item 3 - Property identification no. (PID) (integer)
(See following PID discussion)
- Item 4 } Nodal or grid point connection data for element no. EID
- Item 5 } Numbering starts at lower left and proceeds counterclockwise
- Item 6 } around element (integers)
- Item 7 }
- Item 8 - Material property orientation angle for advanced composite type materials (see following TH discussion)

4. PROPERTY IDENTIFICATION DETERMINATION (PID)

Within a typical ROVAC vane, various properties exist across the vane surface in the form of end plates, boots, adaptors, or varying materials within the structure itself. To accommodate these changes,

the AVM program was set up to include four primary property areas. Typically, these property areas are noted in Figure 8 as PID values 1 through 4,

where:

X_{AP} , X_{BP} , X_{CP} , X_{DP} , and X_{EP} = input values (floating point)
(FORTRAN input = XP1 through XP5)

All CQUADS lying between X_{AP} and X_{BP} will have PID = 1

All CQUADS lying between X_{BP} and X_{CP} will have PID = 2

All CQUADS lying between X_{CP} and X_{DP} will have PID = 3

All CQUADS lying between X_{DP} and X_{EP} will have PID = 4

5. THETA DETERMINATION (TH)

One very promising method of significantly reducing the vane weight within an air-cycle system is through the use of advanced composite materials. To include the possibility for considering materials of this type, a total of four theta regions is included for automated setup on the ROVAC vane model. Typically, these regions are shown in Figure 9 as TH (or theta) values TH1 ... TH4,

where:

X_{ATH} , X_{BTH} , X_{CTH} , X_{DTH} , X_{ETH} = input values (floating point)

TH1, TH2, TH3, TH4 = input values (floating point)
(FORTRAN input = XTH1 through XTH5)
(and TH1 through TH4)

All CQUADS lying between X_{ATH} and X_{BTH} will have TH = TH1

X_{BTH} and X_{CTH} will have TH = TH2

X_{CTH} and X_{DTH} will have TH = TH3

X_{DTH} and X_{ETH} will have TH = TH4

where TH1 ... TH4 = θ_1 ... θ_4
= material property orientation angles defining at which angle the anisotropic or orthotropic properties are related.

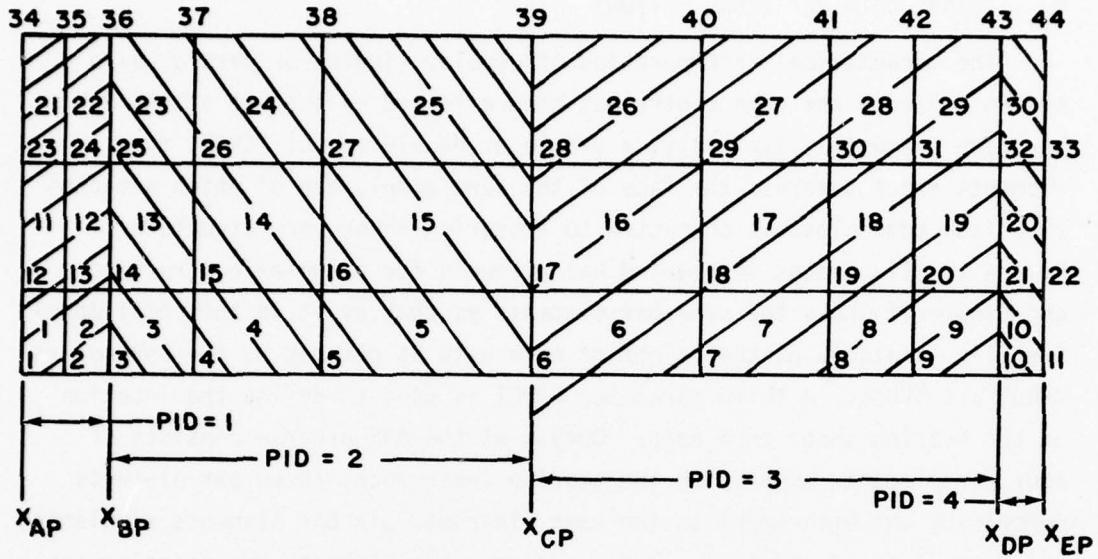

Figure 8. AVM Model Property Identification

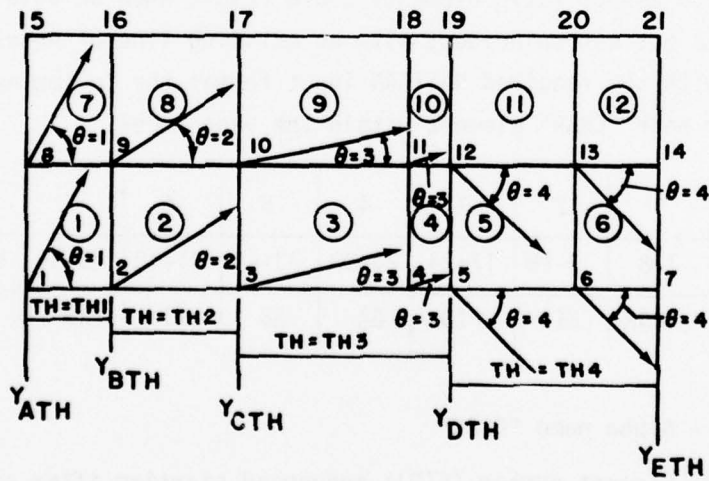

Figure 9. AVM Model Theta Relationship

6. "CBAR" DATA SET (EDGE OPTION)

The mathematical incorporation of double, single, or partial axle systems through the vane center has been effected by the use of NASTRAN bar type elements. Typically, a single or double row of "CBAR" type elements extends across the face of the vane model, one of which attaches to a vane edge closeout connected to a bearing inner race structure. Figure 10 illustrates segregated bar elements for a two-axle structure and Figure 11 shows the same bar elements as they exist in the total model. Specific locations of the height of each axle is defined by the parameters YROD1 and YROD2. A third parameter XROD1 is used to define the location of the bearing inner race edge. Output of the AVM program consists of four bar elements comprising the bearing inner race, three bar elements comprising the attachment to the vane closeout, six bar elements simulating the vane closeout stiffness, and a set of n-bar elements representing the upper and lower axles. In the event that either of the axle y positions do not fall coincident to an existing line of nodes (i.e., nodes 6, 7, 8, 9, 10, Figure 11) the AVM program will automatically generate a set of nodal points to which bar elements may be connected. It should be noted, however, that very high aspect ratio elements could result when an axle position is very close to but not coincident with an existing line of nodes. In accordance with the required NASTRAN input format the following data is included for each "CBAR" element within the vane model.

ITEM NO.	1	2	3	4	5	6	7	8	9
COL. LOC.	1-8	9-16	17-24	25-32	33-40	41-48	49-56	57-64	65-72
VARIABLE	CBAR	EID	PID	GA	GB	X1	X2	X3	F

Item 1 - Alpha name "CBAR"

Item 2 - Element number (EID); sequenced starting after all "CQUAD" elements have been numbered

Item 3 - Property identification number
(see following PID discussion)

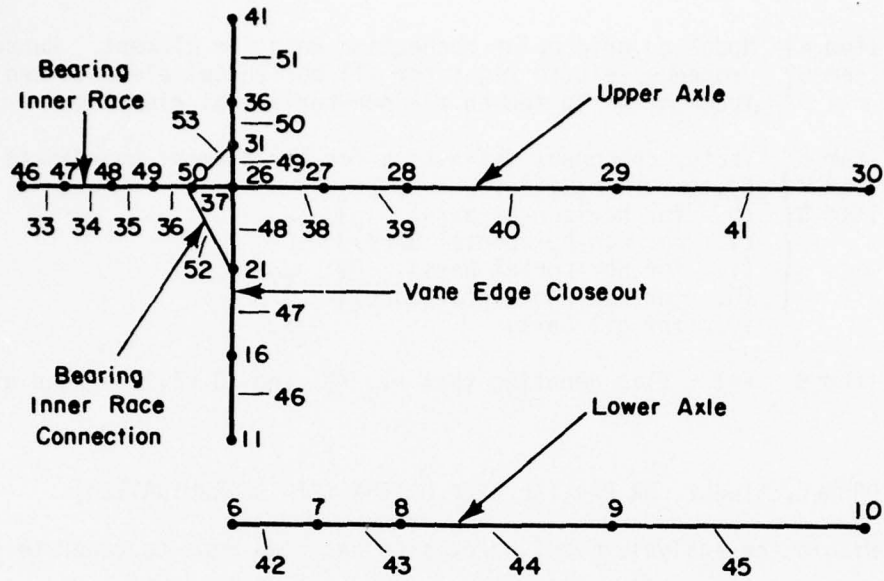

Figure 10. Segregated AVM Bar Elements For Double Axle

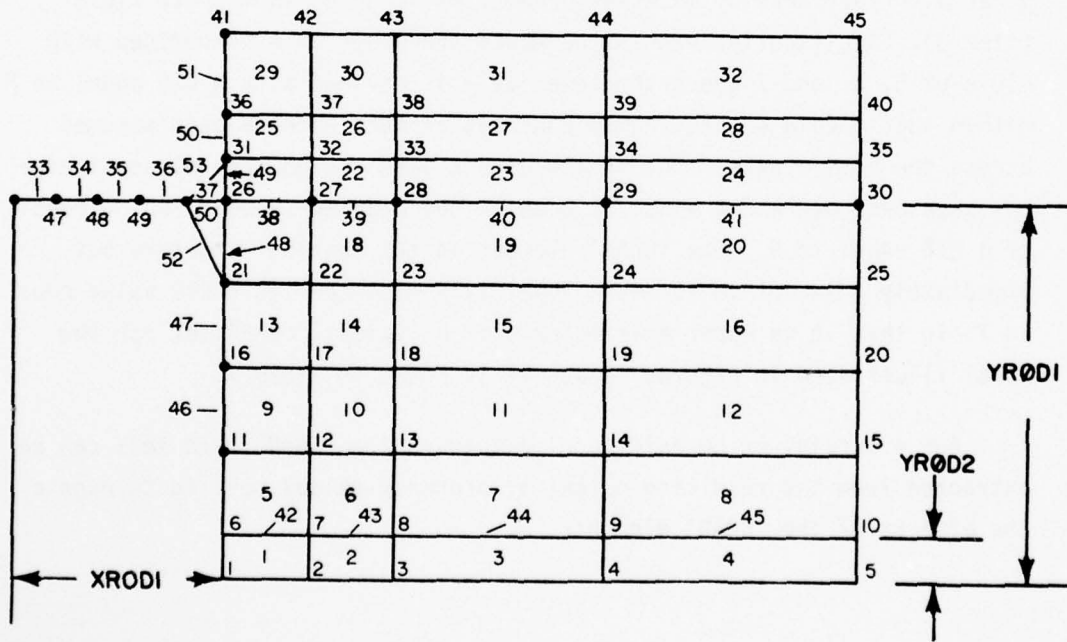

Figure 11. AVM Bar Elements Within Total Model

Item 4 } Nodal or grid point connection data for element. Numbering
 Item 5 } proceeds left to right for all horizontal elements and
 } from bottom to top on all non-horizontal elements.

Item 6 } Vector component definition for bar element coordinate
 Item 7 } system orientation.

Item 8 } (0. for horizontal bars) } = X1
 } (1. for non-horizontal bars) }
 } (1. for horizontal bars) } = X2
 } (0. for non-horizontal bars) }
 } (0. for all bars) } = X3

Item 9 F=1 = flag denoting that X1, X2, and X3 will be read as
 above

7. DOUBLE, SINGLE, OR PARTIAL AXLE OPTION (PID DETERMINATION)

Within the analysis model, provision has been made to generate either a single or double axle model. For the single axle, the upper bearing attachment axle will always be generated without the lower axle. Each of the two axles in the two-axle case have been set up independently of each other with four sets of material properties as noted in the PID field (Item 3). Specifically, within the model the upper axle is defined with PID's of 5, 6, and 7 where the lower axle is defined with a PID equal to 8. Within the immediate vane region constant properties have been assumed across the entire axle. Out of the direct vane region, the closeout edge has been assigned a PID equal to 6 while the bearing support region consists of a PID equal to 5. One "CBAR" element in the bearing structure but immediately adjacent to the vane upper axle also carries a PID value equal to 7, in that it is upper axle material. A typical "CBAR" set for the model illustrated in Figures 10 and 11 is noted in Table 1.

For a partial or no axle model either entire "CBAR" card sets can be extracted from the resulting output or property values revised to negate the effects of the "CBAR" elements.

TABLE 1
"CBAR" OUTPUT FOR FIGURES 10 AND 11

CBAR	33	5	46	47	0.00	1.00	0.00	1
CBAR	34	5	47	48	0.00	1.00	0.00	1
CBAR	35	5	48	49	0.00	1.00	0.00	1
CBAR	36	5	49	50	0.00	1.00	0.00	1
CBAR	37	7	50	26	0.00	1.00	0.00	1
CBAR	38	7	26	27	0.00	1.00	0.00	1
CBAR	39	7	27	28	0.00	1.00	0.00	1
CBAR	40	7	28	29	0.00	1.00	0.00	1
CBAR	41	7	29	30	0.00	1.00	0.00	1
CBAR	42	8	6	7	0.00	1.00	0.00	1
CBAR	43	8	7	8	0.00	1.00	0.00	1
CBAR	44	8	8	9	0.00	1.00	0.00	1
CBAR	45	8	9	10	0.00	1.00	0.00	1
CBAR	46	6	11	16	1.00	0.00	0.00	1
CBAR	47	6	16	21	1.00	0.00	0.00	1
CBAR	48	6	21	26	1.00	0.00	0.00	1
CBAR	49	6	26	31	1.00	0.00	0.00	1
CBAR	50	6	31	36	1.00	0.00	0.00	1
CBAR	51	6	36	41	1.00	0.00	0.00	1
CBAR	52	5	21	50	1.00	0.00	0.00	1
CBAR	53	5	50	31	1.00	0.00	0.00	1

8. "CBAR" SET (OPTION NON-EDGE)

In the previous axle model, an existing set of nodes along an existing y edge was used to define the axle bar elements or one was automatically generated. For some cases, however, it may be required that the axle be modeled across the centroid or some portion of the element other than the element edge. For the latter case, an entirely new set of nodal values is generated. Within the AVM program nodes may be suppressed and the generation of a line of non-edge nodes can be interchanged. Figure 12a illustrates this suppressed mode for a single axle non-edge generation scheme. Node points 51 through 55 have been added to the base model and from which the axle noted in Figure 12b was modeled. All of these nodes are totally independent of any element edge and truly lie across one of the existing elements in the structural model. It becomes obvious, however, that the axles modeled in this case are not inherent to the basic structural model. Some additional modeling will therefore be required to

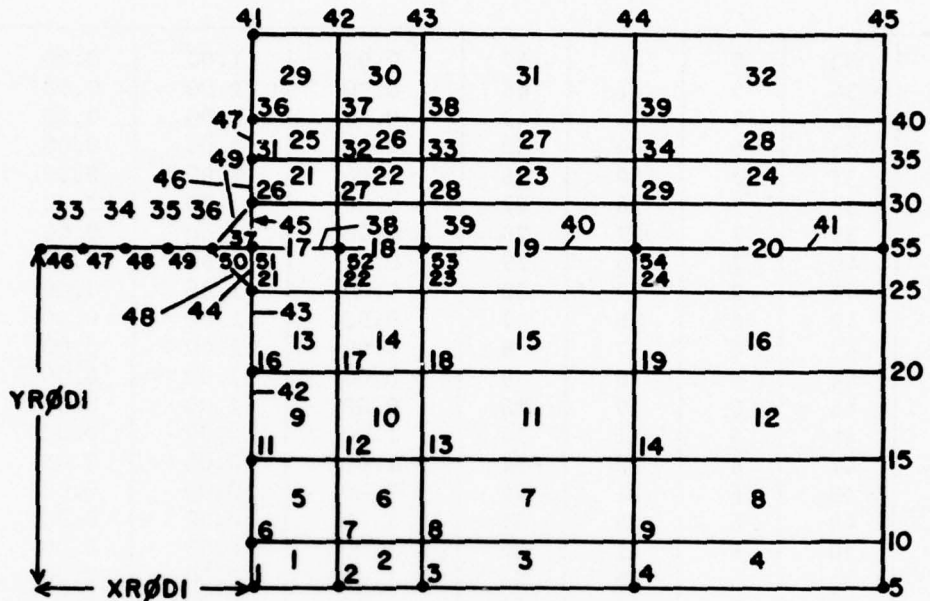

Figure 12a

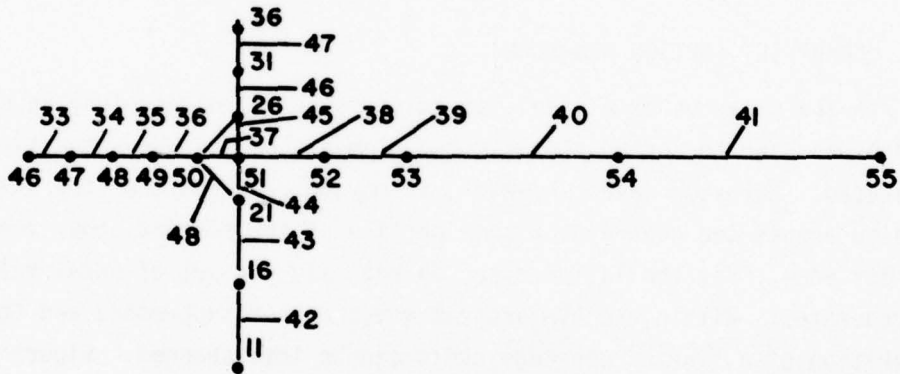

Figure 12b

Figure 12. Non-Edge, Single Axle Model

relate the axes to the model. This additional modeling has been left up to the user and has not been automated into the AVM program.

For the non-edge case, the vane closeout edge is modeled such that two bars are modeled across the left edge of the element divided by the axle. Two additional bars are generated above and below the inner race attachment points as is done in the edge case. All other modeling parameters are identical to the edge case.

9. "SPC" DATA SET (MATHEMATICAL CONSTRAINTS)

Within the AVM program various SPC (Single Point Constraint) sets are also generated. These sets include reaction points, unidirectional bearing constraints, M_z constraints, and symmetry constraints for symmetrical modeling. Each of these SPC sets is discussed in the following four sections.

a. Symmetry Condition

Due to the fact that the vane is symmetrically loaded and dimensionally identical about its centerline, only one half of the vane need be modeled. To effect this symmetry the AVM program selects the appropriate edge nodes along the centerline (Figure 13) and generates an appropriate NASTRAN "SPC1" card for each node point along this centerline edge. The actual constraints used resist both motion in the x direction and rotation about the y axis. The specific SPC1 format output is as follows:

ITEM No.	1	2	3	4	5
COL. LOC.	1-8	9-16	17-24	25-32	33 40
VARIABLE	SPC1	SID	C	G	D

- Item 1 - Alphanumeric name "SPC1"
- Item 2 - Constraint ID number, initialized at SID = 100 (integer) followed by consecutive +1 incrementing
- Item 3 - Constraint factor no. 15 denoting a constraint in the 1 and 5 or X and M_y directions, respectively (integer)
- Item 4 - Nodal point to be constrained (integer)
- Item 5 - N/A (blank)

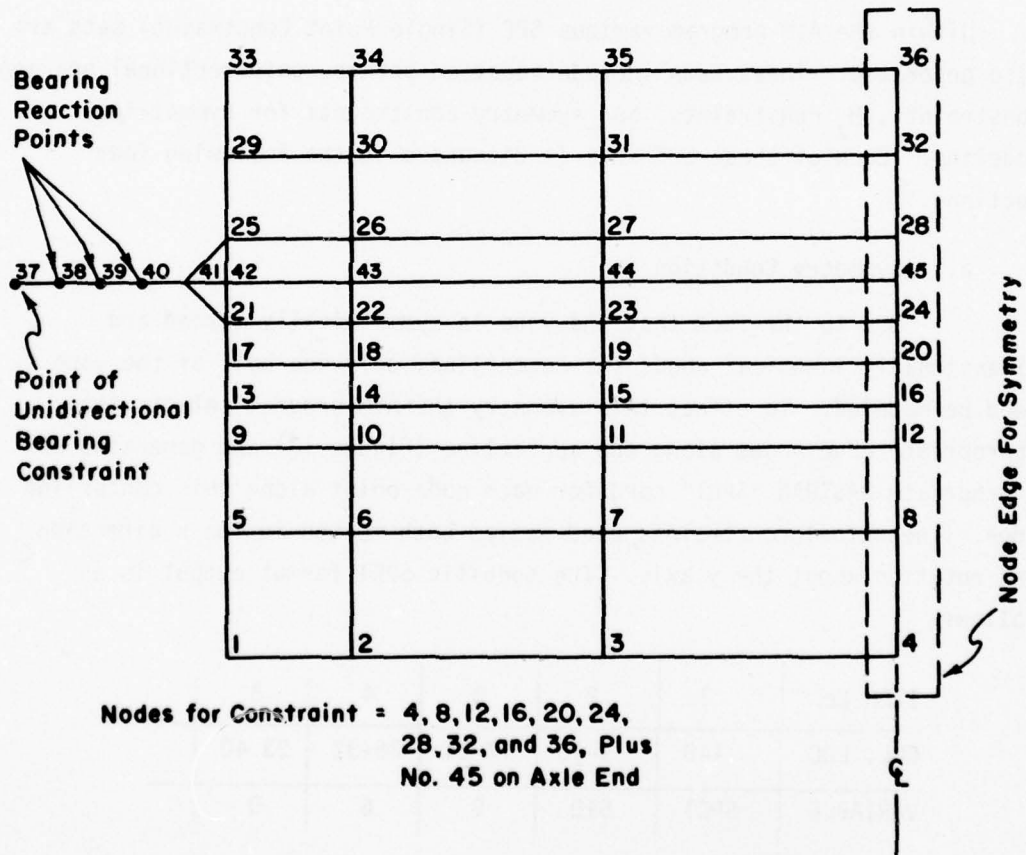

Figure 13. AVM Symmetrical SPC Set Definition

b. Unidirectional Bearing Constraint

Within the analysis model a "SPC1" constraint is generated representing the total restraint existing (in the y plane) at the bearing. At this point y motion is reacted by the ROVAC track, x motion is reacted by the machine end plates, M_x , and M_y are reacted through the rotor and z is fixed because of the y plane constraint. Typically, this bearing constraint is always applied to the left most nodal point (No. 37, Figure 13) on the inner race axle model. For this case, one "SPC1" card is generated with C = 123456. The assigned SPC set number for this card is 500.

c. Reaction Points

Primary loads within the ROVAC vane structure are generated from both rotational and linear inertia effects. Typically, these loads are reacted in the $\pm y$ direction at the bearing inner race mount. This mount in the automated generator consists of the four left most nodal points (i.e., 37 through 40, Figure 13). To satisfy the $\pm y$ reaction, three of these four points must be additionally constrained. This is accomplished through the use of a "SPC1" card containing all three points where C is set equal to 2. The SPC set number for this card is 502.

d. Z Axis Moment Constraint (M_z)

The standard "CQUAD2" NASTRAN M_z constraint set has been represented in the vane model by the SPC set number 501. Within this set all nodal points within the model are constrained in the R3 direction. A point of caution or possible error is presented at this point, in that those "CBAR" elements requiring M_z freedom could adversely be affected through this M_z SPC1 imposition. If this is the case, a separate hand-generated SPC1 set would have to be developed for M_z which would not include nodal points associated with any "CBAR" type elements.

e. Combined Constraints

All of the SPC sets generated for the vane model are combined into a single constraint set. This constraint set is assembled by means of the "SPCADD" card and continuation cards. The final resulting SPC set

for NASTRAN case control is SID = 99. Table 2 is a tabulation of all the SPC sets and SPC combination for the model noted in Figure 13.

TABLE 2
AVM GENERATED CONSTRAINT SET

SPC1	100	15	4						
SPC1	101	15	8						
SPC1	102	15	12						
SPC1	103	15	16						
SPC1	104	15	20						
SPC1	105	15	24						
SPC1	106	15	28						
SPC1	107	15	32						
SPC1	108	15	36						
SPC1	109	15	45						
SPC1	500	123456	37						
SPC1	501	6	1	THRU	45				
SPC1	502	2	38	39	40				
SPCADD	99	100	101	102	103	104	105	106	ABC10
+BC10	107	108	109	500	501	502			

(Reference Figure 13)

10. PROPERTY AND MATERIALS DATA

Quadrilateral properties within the ROVAC model are defined by means of "PQUAD2" cards representing each of the four vane areas previously discussed.

a. "PQUAD2" Data

The specific "PQUAD2" data output for the ROVAC vane model is as follows:

ITEM NO.	1	2	3	4
COL. LOC.	1-8	9-16	17-24	25-32
VARIABLE	PQUAD2	PID	MID	T

Item 1 - Alphanumeric name "PQUAD2"

Item 2 - Property identification no. (PID) (INTEGER)

Item 3 - Material identification no. (references a specific material card where the specific material properties are defined for the property identification (PID) (INTEGER)

Item 4 - Thickness of all elements relating to this property (Real Number)

b. "PBAR" Data

Bar element properties within the ROVAC model are defined by means of four "PBAR" cards representing each of the four axle or bearing-support regions previously discussed. Due to the fact that some of the properties are small and are self-computed by the automated data-generator program, a large field card was required. The specific large field "PBAR" data output for the ROVAC vane model is on two cards as follows:

ITEM NO.	1	2	3	4	5	6
COL. LOC.	1-8	9-24	25-40	41-56	57-72	73-80
VARIABLE	PBAR*	PID	MID	A	I1	QABCDEF1

ITEM NO.	7	8	9
COL. LOC.	1-8	9-24	25-40
VARIABLE	*ABCDEF1	I2	J

Item 1 - Alphanumeric name "PBAR*" where the * flags a large field card and the following four fields of data on the card will be read in fields of 16 rather than 8.

Item 2 - Bar property identification number (PID) (Integer)

Item 3 - Material ID No. (Ref. PQUAD2 card)

Item 4 - Bar cross-sectional area (Real)

Item 5 - Area moment of inertia (Direction 1) (Real)

Item 6 - Coded continuation card flag

Item 7 - Continuation cards related to coded item number 6

(* = large field flag for items 8 and 9)

Item 8 - Area moment of inertia (Direction 2) (Real)

Item 9 - Torsional constant (Real)

c. "MAT1" Data

Each of the "PQUAD2" and "PBAR" cards noted previously contains a material identification number as Item 3. For the ROVAC vane each of these ID numbers is unique for each of the eight property cards. As a result, eight unique materials cards are required for the ROVAC model. Typically, each of these eight materials references are output as follows:

ITEM NO.	1	2	3	4	5	6	7
COL. LOC.	1-8	9-16	17-24	25-32	33-40	41-48	49-56
VARIABLE	MAT1	MID	E	G	MU	RHO	

Item 1 - Alphanumeric name "MAT1"

Item 2 - Materials property identification number per property card reference (Integer)

Item 3 - Young's modulus (Real)

Item 4 - Blank for ROVAC Case (computed within NASTRAN)

Item 5 - Poisson's ratio (Real)

Item 6 - Mass density (Real)

Item 7 - Blank for ROVAC model

11. ROVAC VANE LOADING

As stated previously, vane loads are generated from two primary sources, consisting of rotational and inertia forces generated during air-cycle machine operation. Specifically, the rotational forces result from pure rotor rotation, whereas the inertial force is added due to the effects of in and out movement of the vane through the rotation angle. To simulate these loading values in the ROVAC model, two distinct input sets are generated by the AVM program.

a. Rotational Force ("RFORCE")

The first load condition consists of a rotation force ("RFORCE") data set defining a static loading condition due to a centrifugal force field. Based on the mass properties of the model, a corresponding

centrifugal loading for each element in the model will be generated. The specific ROVAC AVM output for the "RFORCE" data is as follows:

ITEM NO.	1	2	3	4	5	6
COL. LOC.	1-8	9-24	25-40	41-56	57-72	73-80
VARIABLE	RFORCE*	SID	G	CID	A	QRFORCE1

ITEM NO.	7	8	9	10
COL. LOC.	1-8	9-16	17-24	25-32
VARIABLE	+RFORCE1	N1	N2	N3

Item 1 - Alpha name "RFORCE*" where the * flags a large field set and the following 4 fields of data will be read in fields of 16 rather than 8.

Item 2 - Unique load set identification number (Integer) (for ROVAC SID = 20).

Item 3 - Grid point identification number indicating a center of rotation for the ROVAC vane model (Integer).

Item 4 - Blank for ROVAC case indicating that the basic co-ordinate system defines the rotation direction.

Item 5 - Scale factor for rotational velocity in revolutions per unit time (ROVAC = rps).

Item 6 - Coded continuation card flag.

Item 7 - Continuation card related to coded Item No. 6.

Item 8

Item 9 } Rectangular components of rotation direction vector (Real).

Item 10 }

b. Inertia Loading ("GRAV")

The second load condition consists of a gravity vector "GRAV" data set defining a gravity vector simulating an inertia type loading for the ROVAC vane model. Based on the mass properties, then, a corresponding

inertia loading for each element in the model will be generated. The specific ROVAC AVM output for this "GRAV" data is as follows:

ITEM NO.	1	2	3	4	5	6
COL. LOC.	1-8	9-24	25-40	41-56	57-72	73-80
VARIABLE	GRAV*	SID	CID	G	N1	QGRAV1

ITEM NO.	7	8	9
COL. LOC.	1-8	9-16	17-24
VARIABLE	+GRAV1	N2	N3

- Item 1 - Alpha name "GRAV*" where the * flags the large field set noted previously.
- Item 2 - Unique load set identification number (Integer)
(for ROVAC Case SID = 21).
- Item 3 - Coordinate system identification number set to blank (0) for the ROVAC case. (References the basic coordinate system.)
- Item 4 - Actual gravity vector value (Reference the following gravity vector discussion).
- Item 5 }
Item 8 } - Gravity vector components (Real).
Item 9 }
- Item 6 - Coded continuation card flag.
- Item 7 - Continuation card related to coded item No. 6.

c. Gravity Vector (Item 4)

Within the air-cycle machine, it was noted that the vane is traveling about an elliptical path, which results in an in-and-out translation of the vane itself throughout each rotational cycle. The magnitude and direction of this travel is of course controlled by the elliptical cam track and the slots within the rotor are as noted in Section I, Figures 1 and 2. As a result of this in-and-out vane motion at high rotor speeds,

a very significant inertia load is generated on the vane. In addition to this load, a friction load is further imposed as a result of the vane sliding in-and-out of the rotor slot. Both of these forces are represented within the AVM NASTRAN model by means of an acceleration or gravity vector value on a GRAV input card. The actual value of this vector can be derived from several sources or it could be computed from the machine geometrical parameters. The provision for computing the value is provided by means of eight input parameters ALDATA(1) through ALDATA(8). For this provision, the specific geometric equation would have to be added to the program. For the analysis conducted in this report, a representative input value was derived from an additional computer program which specifically analyzes the geometric relationship. The actual AVM input value is an acceleration value noted in inches per second.

d. Combined Loads

Both the "RFORCE" load and "GRAV" load sets are combined into a common load set through the use of a simple load card. For the ROVAC case, the rotational and gravity force sets have been identified as 20 and 21, respectively. The resulting combined load set has been identified as number 30 for NASTRAN case control. The specific ROVAC AVM output for the "LOAD" set is as follows:

ITEM NO..	1	2	3	4	5	6	7
COL. LOC.	1-8	9-16	17-24	25-32	33-40	41-48	49-56
VARIABLE	LOAD	SID	S	S1	L1	S2	L2

Item 1 - Alpha name "LOAD"

Item 2 - Load set ID number (SID - 30 for ROVAC AVM)

Item 3 - Scale factor for Item No. 2 load set (S = 1.000 for ROVAC AVM)

Item 5 }- Load set identification numbers to be combined into the SID
 Item 7 }- set. For the ROVAC case, L1 = 20 and L2 = 21.

Item 4 }- Respective scale factors (S1, S2) for load sets (L1, L2).

Item 6 }- for ROVAC AVM S1 = S2 = 1.000.

e. Parameter Usage ("WTMASS" and "GRDPNT")

In accordance with NASTRAN requirements and desired ROVAC output two "PARAM" cards are generated by the AVM program. These include a grid point "GRDPNT" and a weight mass "WTMASS" parameter in accordance with the following:

	ITEM NO.	1	2	3
	COL. LOC.	1-8	9-16	17-24
CARD 1	VARIABLE	PARAM	WTMASS	.002588
CARD 2	VARIABLE	PARAM	GRDPNT	0

The weight mass parameter ("WTMASS") will result in all structural mass matrix terms being multiplied by the value contained in Item 3. For the ROVAC case, the mass parameter is $1/g$, resulting in:

$$F = r \omega^2 m = \frac{r \omega w}{g}$$

where

$$1/g = 1/(32.2)(12) = .002588 \text{ weight mass parameter}$$

F = force

ω = angular velocity

r = radius

The grid point ("GRDPNT") parameter will result in the execution of the weight generator package where principal vane masses, centers of gravity, and inertias about the center of gravity will be generated. The value contained as Item 3 indicates the grid point to be used as a reference point for this information. For the AVM program, this value has been set at zero, and as a result the reference point is taken as the origin of the basic coordinate system.

f. Rotational Axis Definition

The generation of rotational forces for ROVAC studies require the definition of a rotational axis about which the vane shall rotate.

AFFDL-TR-77-49

As noted previously in the RFORCE output, Item 3, (G) is required to define this axis specifically. The value G is a designated grid point lying on the axis of rotation from which the centrifugal force is derived. For the ROVAC AVM case, this grid point is an entirely independent point where:

$$x = z = 0.0$$

$$y = y_0 = \text{AXIS}$$

AXIS = distance from vane edge to the center of rotation

g. Program Termination

For program termination, the required "ENDDATA" card is self-generated within the ROVAC AVM program.

SECTION III

AVM PROGRAM INPUT AND OPERATION

As noted in the program listing contained in Appendix A, the AVM program consists of a main program called VANE and seven associated subroutines. These subroutines and their respective functions are as follows:

- READIN - Program to simply read in and store all of the required program input data.
- GRID - Program to generate all of the X-Y co-ordinate values associated with each nodal point within the structural model. (output to TAPE 7)
- CQUAD2 - Program to calculate and set up all of the quadrilateral elements within the finite element model. (output to TAPE 7)
- LISTIN - Program to write out all input data and associated internally computed input values. (output to TAPE 6)
- CBAR - Program to calculate and set up all of the bar elements within the finite element model. (output to TAPE 7)
- CALCIN - Program to calculate and set up all of the PQUAD2, PBAR, MATI, SPC1 (500), SPC1 (501), SPC1 (502), RFORCE, GRAV, PARAM (WTMASS), PARAM (GRDPNT), GRID (Rotational), and ENDDATA cards required for the finite element analysis. (output to TAPE 7)
- SPC - Program to calculate and set up all of the constraint cards required to model the symmetry conditions associated with the vane model. (output to TAPE 7)

a. Input Subscripts

AVM program input variables are generally related to eight sections or materials property areas contained within the model. Four of these areas are contained within the vane itself while the remaining four

are restricted to the vane axles. These eight areas are related to property variables within the program by means of subscripts or arrays numerically equivalent to the area number. Each of these eight areas is noted in Figure 14 and defined as follows:

- A1 through A4 - Four areas across vane face (left to right where thickness, ρ , μ , E , and other properties may be varied).
- A5 - Upper axle bearing-support area extending to the left of the axle transition area.
- A6 - Axle transition and vane closeout areas located to the immediate left of the vane itself.
- A7 - Upper axle extending through the vane and into the upper axle bearing-support area.
- A8 - Lower axle area extending through the vane.

b. Computed Variables

Within the AVM program axle areas and axle area moments of inertia (I_{xx} and I_{yy}) are self computed and automatically programmed into the NASTRAN output deck. The computations are based entirely on AVM input and are individually related to axle areas 5 through 8.

Within NASTRAN vane accelerations and inertia, forces are computed based on a vane speed in revolutions per second. The resulting NASTRAN output from the AVM program automatically accounts for these units. Gravity acceleration values can also be computed within the AVM program if desired. These values are based upon air-cycle machine design criteria as defined by AVM program input variables. The actual computation is based on input data noted as ALDATA (1) through ALDATA (8).

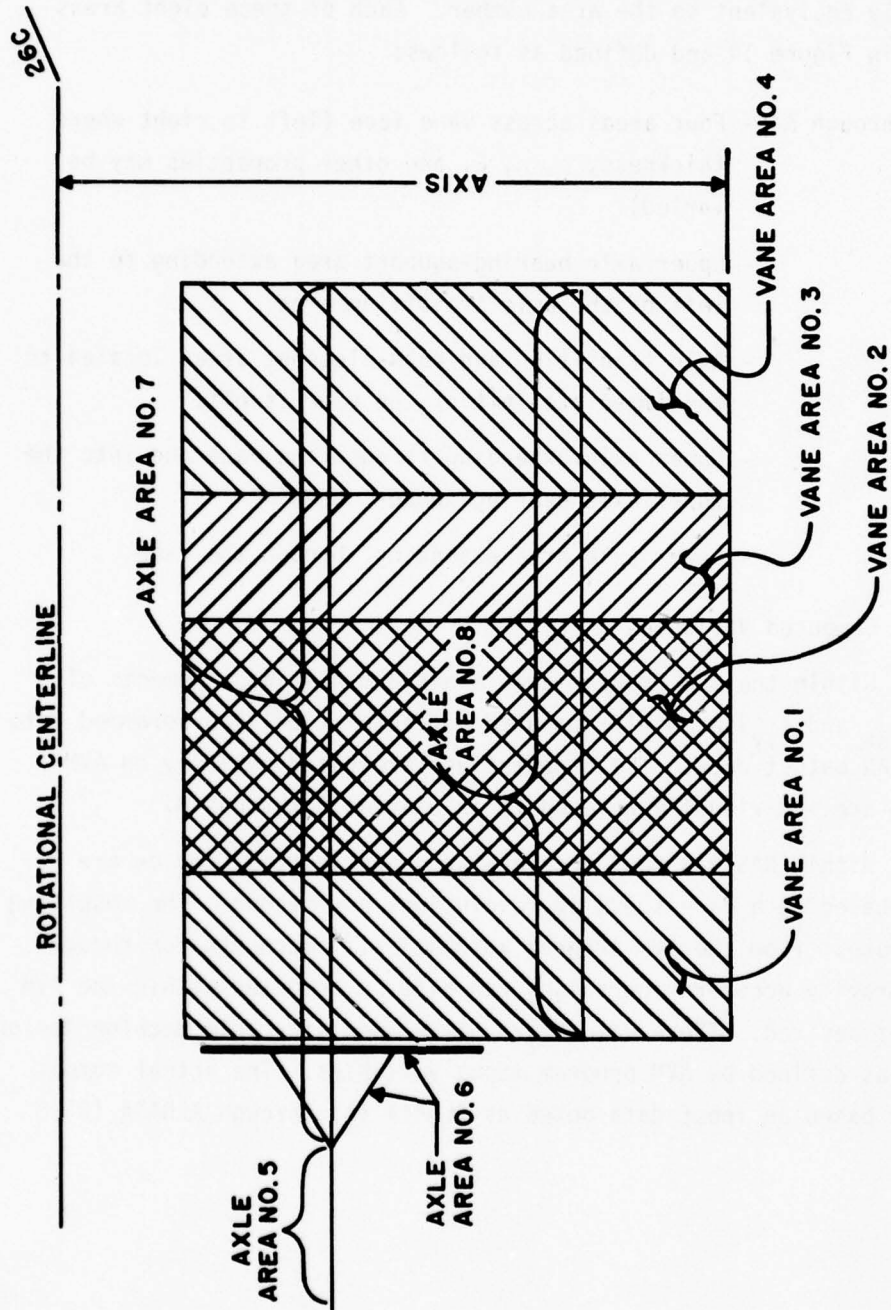

Figure 14. Vane and Axle Area Definition

c. Program Input

Input to the AVM program is accomplished by means of card or card sets containing all of the variables required for AVM program operation. Each of the individual cards or card sets is described as follows:

CARD 1 - INPUT VARIABLES = NPX, NPY, PRINT

FORMAT = 215, L1

NPX = number of points to be input along the X axis of the vane from which specific X values will be calculated for each nodal point.

NPY = same as NPX only for Y axis and Y values

PRINT = T or F value indicating whether or not an output listing of the program input is desired.

CARD 2 - INPUT VARIABLES = XIN(I) where I = 1 to NPX
(SET)

FORMAT = 8F10.0

XIN = actual X values to be input for the X sectioning of the vane structure (values in inches).

CARD 3 - INPUT VARIABLES = YIN(I) where I = 1 to NPY
(SET)

FORMAT = 8F10.0

YIN = actual Y values to be input for the Y sectioning of the vane structure (values in inches).

CARD 4 - INPUT VARIABLES = XP1, XP2, XP3, XP4, XP5

FORMAT = 8F10.0

XP1 through XP5 = 5 X values which divide the vane into four distinct areas for the future assignment of varying material properties across the vane face (values in inches).

CARD 5 - INPUT VARIABLES = XTH1, XTH2, XTH3, XTH4, XTH5

FORMAT = 8F10.0

XTH1 through XTH5 = 5 X values which divide the vane into four distinct areas for the future assignment of varying theta values defining material property orientation angles across the vane face (values in inches).

CARD 6 - INPUT VARIABLE = TH1, TH2, TH3, TH4

FORMAT = 8F10.0

TH1 through TH4 = actual property orientation angle (α) in each of the four areas defined by card number 4 (value in degrees as measured from an axis along the bottom of the vane from a leftwise origin where up is a positive value).

CARD 7 - INPUT VARIABLES - NROD, XROD1, YROD1, YROD2, NEOPTIN

FORMAT = I10, 3F10.0, I10

NROD = number of axles to be modeled within the vane structure (restricted to 1 or 2).

XROD1 = left most origin of the upper axle which defines the length of axle extending between the bearing and vane edge (value in inches).

YROD1 = distance of upper axle from the lower edge of the vane structure (value in inches).

YROD2 = distance of the lower axle from the lower edge of the vane structure (value in inches).

NEOPTIN = defines if the non-edge option is to be selected (any number greater than or equal to 1 will result in a non-edge model).

CARD 8 - INPUT VARIABLES - IFMT

FORMAT = I5

IFMT = flag indicating in what format the remaining data is to be read in. If IFMT is not equal to 1 the program will skip card sets 9 through 13. This option is for the input of more detailed properties in the format required for composite materials. The option currently is not in use and IFMT must be set equal to one (Value = 1).

CARD 9 - INPUT VARIABLE = XJ5, XJ6, XJ7, XJ8

FORMAT = 40X, 4F10.0

XJ5 through XJ8 = axle torsional constant in respective areas 5 through 8 as noted in Figure 9 (axle properties restricted to circular section).

CARD 10 - INPUT VARIABLES = THICK1, THICK2, THICK3, THICK4,
RADIUS5, RADIUS6, RADIUS7, RADIUS8

FORMAT = 8F10.0

THICK1 through THICK4 = vane thickness values in respective vane areas 1 through 4 (values in inches)

RADIUS5 through RADIUS8 = Radius values of axle components as defined by the axle areas noted in Figure 9 (values in inches).

CARD 11 - INPUT VARIABLES - E1, E2, E3, E4, E5, E6, E7, E8

FORMAT = 8 (2X, A8)

E1 through E8 = modulus (E) values for vane areas 1 through 4 and axle areas 5 through 8. Input is in E format (i.e., 3.0E7 for steel)

CARD 12 - INPUT VARIABLES = XMU1, XMU2, XMU3, XMU4, XMU5, XMU6,
XMU7, XMU8

FORMAT = 8F10.0

XMU1 through XMU8 = Poisson's Ratio values for vane areas
1 through 4 and axle areas 5 through 8.

CARD 13 - INPUT VARIABLES = RHO1, RHO2, RHO3, RHO4, RHO5, RHO6,
RHO7, RHO8

FORMAT = 8F10.0

RHO1 through RHO8 = density values for vane areas 1 through
4 and axle areas 5 through 8 (values in
 lb/in^3).

CARD 14 - INPUT VARIABLES - VEL, AXIS, GRAV

FORMAT = EF10.0

VEL = compressor vane rotational velocity (value in
revolutions per minute).

AXIS = distance from vane edge to center of rotation for
compressor vane (value is in inches; ref. AXIS
Figure 9).

GRAV = gravity acceleration value input at the option of
the user. If GRAV is equal to zero, a gravity
acceleration value based on the data supplied on
Card No. 15 will be computed (value = in/sec^2).

CARD 15 - INPUT VARIABLES = ALDATA(1), ALDATA(2), ALDATA(3), ALDATA(4),
ALDATA(5), ALDATA(6), ALDATA(7), ALDATA(8) (*)

FORMAT = 8F10.0

ALDATA(1) through ALDATA(8) = algorithm data variables 1
through 8 for computing the
gravity acceleration value to
simulate the vane forces due to
the inertia effects resulting
from the elliptical path or rota-
tion within the air cycle ma-
chine. (*)

*Currently not set up within the AVM program (blank card required).

d. Data Summary

A complete summary of all associated input variables and input locations is presented in Table 3.

e. Test Cases

Four test cases were set up to check out the capabilities of the AVM program. Each of these cases is included in the section as sample I/O examples of the AVM program. AVM capabilities in addition to those noted in these four cases should be individually checked out by the user prior to running within NASTRAN.

- CASE 1 Edge Model - Two-axle model where both the upper and lower axles fall on existing lines of nodes. (Bearing-support axle at bottom).
- CASE 2 Self-Generating Edge - Two-axle model where the upper axle falls on an existing nodal line and the lower axle requires a self-generated edge. This model is also representative of an existing vane in an air cycle machine.
- CASE 3 Non-Edge Option - Two-axle model where the lower axle is designed to fall between two nodal lines. For this case, a separate axle independent of the vane structure is generated resulting in 15 rows of elements rather than the 16 noted in Case No. 2.
- CASE 4 Non-Edge Option with Cutout - Example application of a non-edge case where a model has been modified to include 3 cutout holes in the vane face.

f. Program Input/Output

Specific input data for each of the test cases 1 through 3 is noted in Table 4. Test case 4 is not included because this case simply extracted "CQUAD" and "GRID" cards from test case 3 output to simulate

TABLE 3
AVM INPUT DATA SUMMARY

CARD SET	COLUMN LOCATION									
	1-5	6-10	11-20	21-30	31-40	41-50	51-60	61-70	71-80	
1	NPX	NPY	(PRINT)							
2	XIN1 XIN9	XIN2 XIN10	XIN3 XIN11	XIN4 XIN12	XIN5 XIN13	XIN6 XIN14	XIN7	XIN8 XIN(NPX)		
3	YIN1 YIN9	YIN2 YIN10	YIN3 YIN11	YIN4 YIN12	YIN5 YIN13	YIN6 YIN14	YIN7	YIN8 YIN(NPY)		
4	XP1	XP2	XP3	XP4	XP5					
5	XTH1	XTH2	XTH3	XTH4	XTH5					
6	TH1	TH2	TH3	TH4						
7	NR0D	XR0D1	YR0D1	YR0D2	NEOPTIN					
8	IFMT									
9										
10	THICK1	THICK2	THICK3	THICK4	J5	RADIUS5	RADIUS6	RADIUS7	RADIUS8	J8
11	E1	E2	E3	E4	E5	E6	E7	E8		
12	MU1	MU2	MU3	MU4	MU5	MU6	MU7	MU8		
13	RHO1	RHO2	RHO3	RHO4	RHO5	RHO6	RHO7	RHO8		
14	VEL	AXIS	GRAV							
15	ALDATA1	ALDATA2	ALDATA3	ALDATA4	ALDATA5	ALDATA6	ALDATA7	ALDATA8		

TABLE 4
INPUT DATA FOR AVM TEST (CASES 1, 2, AND 3)

1234567890	1234567890	1234567890	1234567890	1234567890	1234567890	1234567890	1234567890	Col. Loc.
14	10T							TEST CASE NO. 1
0.0	0.25	0.50	0.75	1.0	1.1	1.2	1.3	
1.4	1.5	1.75	2.0	2.25	2.5			
0.0	0.4	0.0	0.8	1.0	1.1	1.2	1.4	
1.6	1.8							
0.0	0.5	1.0	1.2	2.5				
0.0	0.5	1.0	1.2	2.5				
0.0	0.0	0.0	0.0	0.0				
0.0	2-1.0	0.4	1.2					
1								
0.75	0.75	0.75	0.75	.75	.35	.35	.35	
3.0E7	3.0E7	3.0E7	3.0E7	2.8E7	2.3E7	2.8E7	2.3E7	
0.25	0.25	0.25	0.25	0.30	0.30	0.30	0.30	
0.28	0.23	0.29	0.28	0.25	0.25	0.28	0.28	
2000.	4.0	380000.						
0.0								
1234567890	1234567890	1234567890	1234567890	1234567890	1234567890	1234567890	1234567890	Col. Loc.
28	10T							TEST CASE NO. 2
0.0	.07	.147	.2	.3	.4	.45	.5	
.55	.6	.652	.752	.852	.952	1.052	1.152	
1.3	1.5	1.75	2.	2.25	2.5	2.75	3.	
3.25	3.5	3.75	4.0					
0.	.2	.4	.6	.3	1.	1.2	1.4	
1.6	1.8	2.	2.2	2.4	2.0	2.7	2.825	
0.	.147	.652	2.	4.				
0.	.147	.652	2.	4.				
0.	0.	0.	0.	0.				
1	2	-.9	2.0	.17				
.374	.374	.374	.374	.4	.2	.125	.035	
3.0E7	1.0E7	3.5E6	3.5E6	3.0E7	3.0E7	3.0E7	3.0E7	
.32	.3	.28	.28	.32	.32	.32	.32	
.28	.15	.066	.066	.28	.23	.28	.23	
3100	5.5	380000.						
1.1	2.	3.	4.	5.	6.	7.	8.	
1234567890	1234567890	1234567890	1234567890	1234567890	1234567890	1234567890	1234567890	Col. Loc.
28	10T							TEST CASE NO. 3
0.0	.07	.147	.2	.3	.4	.45	.5	
.55	.6	.652	.752	.852	.952	1.052	1.152	
1.3	1.5	1.75	2.	2.25	2.5	2.75	3.	
3.25	3.5	3.75	4.0					
0.	.2	.4	.6	.3	1.	1.2	1.4	
1.6	1.8	2.	2.2	2.4	2.6	2.7	2.825	
0.	.147	.652	2.	4.				
0.	.147	.652	2.	4.				
0.	0.	0.	0.	0.				
1	2	-.9	2.0	.17	2			
.374	.374	.374	.374	.4	.2	.125	.035	
3.0E7	1.0E7	3.5E6	3.5E6	3.0E7	3.0E7	3.0E7	3.0E7	
.32	.3	.28	.28	.32	.32	.32	.32	
.28	.15	.066	.066	.28	.25	.28	.28	
3100	5.5	380000.						
1.1	2.	3.	4.	5.	6.	7.	8.	

AFFDL-TR-77-49

the lightning holes in an early ROVAC vane design. A final version of this No. 4 model with triangular elements added to the hole area is included in Appendix B.

Details as to element and nodal numbering for each of the test cases are noted in the twelve calcomp plots included in Appendix B. Also noted in this appendix are the abbreviated output listings for each of the test cases.

SECTION IV
VANE ANALYSIS SETUP

Twenty-two vanes (total) were setup within the program and analyzed by means of both NASTRAN and the AVM program. The overall analysis was conducted in three parts, which ranged from a very minimal design change to a total redesign of the vane itself. The first part consisted of a direct substitution analysis, whereby the ROVAC vane structure, with the associated bearing, bearing axle supports, and vane boot, was retained in its entirety. The second and third parts of the study involved the elimination of axles, boots, and vane thickness restrictions associated with the ROVAC vane design.

1. PART I (ROVAC AND ADVANCED COMPOSITES)

The Part I analysis consisted of ten NASTRAN models representing ten graphite fiber materials variations within the ROVAC vane design. For this design the concept of using a boot and axle system (Figures 4 and 5) was retained and varied orthotropic materials properties were introduced which effectively replaced the existing Graphite Compact vane. The ten materials considered within the analysis survey were as follows:

- CASE 1 - A high strength (HS) layup consisting of 90% 0-degree fibers and 10% 90-degree fibers within the vane structure. The layup is totally symmetric with the 0-degree fiber being defined as a fiber lying across the length (8 inch section) of the vane. A 60% fill ratio was assumed.
- CASE 2 - A high strength (HS) layup consisting of 10% 0-degree fibers and 90% 90-degree fibers within the vane structure. (90-degree rotation of test case 1 layup)
- CASE 3 - A high strength (HS) layup consisting of +45-fibers throughout the entire vane thickness. The layup is totally symmetric and assumes a 60% fill ratio.

CASE 4 }- Each of these two cases is parallel to case No.'s 1 and 2
CASE 5 } respectively. The only exception is that the high
strength (HS) fiber (Cases 1 and 2) is replaced by a high
modulus (HM) fiber for cases 4 and 5.

CASE 6 - Special higher yield version of Case 3.

CASE 7 - A 21 KSI fiber layup consisting of a unit symmetric layup
involving three 0-degree layers, a +45-degree, a -45-degree
layer, and one final 90-degree layer. Property data was
derived by means based on fiber properties noted in
Reference 6.

CASE 8 - A 90-degree rotation of the test case 7 layup.

CASE 9 - A compression-molded vane of chopped filaments; 21 KSI
fibers were assumed and orientation is random, resulting
in an isotropic block of vane material.

CASE 10 - Baseline case on which materials substitution was effected.
Specifically, this consists of a sintered metal matrix
carbon graphite compact material. The material is
essentially isotropic in nature and can be modeled
several ways within NASTRAN.

a. Basepoint Analysis (ROVAC, Case 10)

Prior to conducting a detailed materials substitution survey, a
basepoint or baseline comparison analysis was conducted. The basepoint
analysis consisted of the ROVAC graphite compact vane modeled through the
use of isotropic NASTRAN MATI input cards. Several analysis checks and
debug runs were required for each of the associated load subcases. A
comparison of all analysis runs yielded good correlation and resulted in a
final baseline run of a high confidence level. The basepoint analysis
model consisted of an AVM two-axle system involving 482 gridpoints, 432
quadralateral elements, and 67 bar-type elements. The resulting basepoint
model is illustrated in Appendix B Figures B-4 through B-6. A listing of
the NASTRAN input with the exception of materials variation input is
contained in Appendix C.

The overall results of the analysis compared quite favorably with both test results and computations from air-cycle machine analysis programs. Typically, bearing reactions, deflections, and vane shapes were very plausible values resulting in highly reliable stress/strain output for the analysis case. A summary of the results of the MAT1 final run are noted in the first row of Table 5.

A second basepoint run was also made for which a MAT2 input mode was used. This was done to validate the MAT2 input methods discussed in a later section of this report. The MAT2 results correlated very well, as can be noted in Table 5.

TABLE 5
BASELINE COMPARISON SUMMARY

	Lower Left Vane Deflect	Vane Center Deflection	Bearing Atatch Deflection	Top Center Deflection	Bearing Load
MAT1 BASEPOINT	.000255	.00291	.0000707	.00298	971
MAT2 BASEPOINT	.000256	.00291	.0000707	.00298	975

(Deflections = inches, Load = lbs)

b. Advanced Composites Analysis

Basically this analysis consisted of nine NASTRAN runs, each involving a different set of MAT2 data which represented the varied orthotropic parameters for analysis cases 1 through 9. The first step of the analysis was to devise and tabulate the basic fiber, lamina, and laminate properties associated with the various analysis cases. This was accomplished by extracting basic filament or specimen data (References 1, 2, and 4) and applying this data to the SQ5 program (Reference 3) to obtain basic laminate properties. A summary of the extracted data and resulting SQ5 properties is contained in Table 6. From this data the basic bulk data G values required by NASTRAN can be derived for MAT2 input. A complete description of how the MAT2 values G_{11} , G_{12} , G_{13} , G_{22} , G_{23} , and G_{33} , were derived and run is included in the following discussion.

TABLE 6
ASSOCIATED FILAMENT AND LAMINATE PROPERTIES

	(ISOTROPIC) CARBON COMPACT	B .60 FILL HS-FIBER [0 _g /90]s	C .60 FILL HS-FIBER [0]	D .60 FILL HS - FIBER [+45]	E .60 FILL HM-FIBER [0 _g /90]s	F .60 FILL HM-FIBER [0]	G .60 FILL HM-FIBER [+45]	H .60 FILL AS-FIBER [0 ₃ /+45/90]s 21 KSI	I (ISOTROPIC) MOLDED CHOPPED GRAPHITE
E _y (Msi)	3.5	19.0	21.0	2.34	22.6	25.0	2.38	12.39	13.5
E _y (Msi)	3.5	3.6	1.7	2.34	4.1	1.7	2.38	6.23	13.5
G _{xy} (Msi)		.65	.65	5.52	.65	.65	6.46	2.27	5.2
M _{xy}	.28	.20	.21	.801	.26	.30	.83	.3028	.298
M _{yx}	.28	.0378	.017	.801	.0471	.020	.83	.152	.298
ρ (lbs/in ³)	.066	.056	.056	.056	.056	.056	.058	.056	
F _x ^{TU} (Ksi)	8.0	163.0	180.0	23.2	99.0	110.0	16.9	75 **	34.0
F _y ^{TU} (Ksi)	8.0	26.0	8.0	23.2	15.0	4.0	16.9	38 **	34.0
F _{yy} ^{SU} (Ksi)	11.5	15.0	12.0	65.5	12.0	9.0	43.2	30 **	8.0
F _x ^{CU}	39.0	163.0	180.0	23.9	92.0	100.0	18.0		52.0
F _y ^{CU}	39.0	45.0	30.0	23.9	28.0	20.0	18.0		52.0

(X = XX = 11 = Longitudinal, Y = yy = 22 = Transverse)
**Extrapolated from [0₃, +45, 90]s (Reference 6)

(1) MAT2 (NASTRAN Input)

The NASTRAN bulk data input for the anisotropic case consists of:

$$\begin{pmatrix} \sigma_1 \\ \sigma_2 \\ \tau_{12} \end{pmatrix} = \begin{bmatrix} G_{11} & G_{12} & G_{13} \\ G_{12} & G_{22} & G_{23} \\ G_{13} & G_{23} & G_{33} \end{bmatrix} \begin{pmatrix} \epsilon_1 \\ \epsilon_2 \\ \gamma_{12} \end{pmatrix} \quad (1)$$

The values associated with the above matrix are related through the Reference 2 equation:

$$\begin{pmatrix} \sigma_x \\ \sigma_y \\ \sigma_z \\ \tau_{xy} \\ \tau_{yz} \\ \tau_{xz} \end{pmatrix} = \begin{bmatrix} Q_{11} & Q_{12} & Q_{13} & 0 & 0 & 0 \\ Q_{12} & Q_{22} & Q_{23} & 0 & 0 & 0 \\ Q_{13} & Q_{23} & Q_{33} & 0 & 0 & 0 \\ 0 & 0 & 0 & Q_{44} & 0 & 0 \\ 0 & 0 & 0 & 0 & Q_{55} & 0 \\ 0 & 0 & 0 & 0 & 0 & Q_{66} \end{bmatrix} \begin{pmatrix} \epsilon_x \\ \epsilon_y \\ \epsilon_z \\ \gamma_{xy} \\ \gamma_{yz} \\ \gamma_{xz} \end{pmatrix} \quad (2)$$

where:

$$Q_{11} = \frac{E(1-\mu)}{(1+\mu)(1-2\mu)} \quad (2a)$$

$$Q_{12} = Q_{13} = Q_{23} = \frac{\mu E}{(1+\mu)(1-2\mu)} \quad (2b)$$

$$Q_{44} = G_{xy} \quad (2c)$$

$$Q_{55} = G_{yz} \quad (2d)$$

$$Q_{66} = G_{xz} \quad (2e)$$

and

$$\mu_{12} E_{22} = \mu_{21} E_{11} \quad (3)$$

The actual bulk data NASTRAN conversion consists of Equation 2 Q values and $G_{33} = G_{xy}$. Further restricting the vane to an in-plane $G_{13} = G_{23} = 0$,

from which Equation 1 becomes:

$$\begin{pmatrix} \sigma_1 \\ \sigma_2 \\ \tau_{12} \end{pmatrix} = \begin{bmatrix} \frac{E_{11}}{1-\mu_{12}\mu_{21}} & \frac{\mu_{21}E_{11}}{1-\mu_{12}\mu_{21}} & 0 \\ \frac{\mu_{21}E_{11}}{1-\mu_{12}\mu_{21}} & \frac{E_{22}}{1-\mu_{12}\mu_{21}} & 0 \\ 0 & 0 & G_{xy} \end{bmatrix} \begin{pmatrix} \epsilon_x \\ \epsilon_y \\ \gamma_{xy} \end{pmatrix} \quad (4)$$

(a) Analysis Case 1 (MAT2 Input)

For the case of $[0_9, 90]_5$ and from Table 6, which was prepared via composites program SQ5 (Reference 3), the following values are extracted: $E_{11} = 19.0(10^6)$, $E_{22} = 3.6(10^6)$, $G_{xy} = .65(10^6)$, and $\mu_{12} = .20$, $\mu_{21} = .0378$.

From Equations 1 and 4:

$$\begin{aligned} G_{11} &= (10^6)19.0/[1-(.20)(.0378)] = 19.44(10^6) \\ G_{12} &= (10^6)(.0378)(19.0)/.99244 = .724(10^6) \\ G_{22} &= 3.6(10^6)/.99244 = 3.63(10^6) \\ G_{13} &= G_{23} = 0 \\ G_{33} &= .65(10^6) \end{aligned}$$

For the ROVAC AVM input the appropriate MAT2 input for Areas 3 and 4 is as follows:

ITEM NO.	1	2	3	4	5	6	7	8	9
COL. LOC.	1-8	9-16	17-24	25-32	33-40	41-48	49-56	57-64	65-72
VARIABLE	MAT2	MID	G11	G12	G13	G22	G23	G33	RHØ
Area 3 Input	MAT2	3	19.14+6	.724+6	-	3.63+6	-	.65+6	.056
Area 4 Input	MAT2	4	19.14+6	.724+6	-	3.63+6	-	.65+6	.056
Area 2 Input	MAT2	2	24.84+6	4.47+6	-	15.54+6	-	4.93+6	.146

Additional extrapolations or computations were utilized within the analysis for material Areas 1 and 2 (Figure 14). Area 1, being a steel edge of the vane boot, could be simulated by means of a MAT1 bulk data card. Since this was the case, no MAT2 computations were required, because the original MAT1 property card was retained. For Area 2, some form of anisotropic property has to be modeled to represent the boot which houses the composite vane. Typically, this was accomplished by assuming a 60/40 ratio of composite-to-steel structure from which modulus values were computed and checked by means of the SQ5 composites laminate program. Actual differences in modulus values between a direct proportioning method and SQ5 were very minimal. The resultant output is as follows:

$$E_{11} = 23.55(10^6), E_{22} = 14.74(10^6), G_{xy} = 4.93(10^6)$$

$$\mu_{12} = .288, \text{ and } \mu_{21} = .180 \text{ (reference Equation 3),}$$

from which (using Equations 1 and 4) we obtain:

$$G_{11} = \frac{E_{11}}{1 - \mu_{12}\mu_{21}} = \frac{23.55}{.948} = 24.84(10^6)$$

$$G_{22} = \frac{E_{22}}{1 - \mu_{12}\mu_{21}} = \frac{14.74}{.948} = 15.54(10^6)$$

$$G_{13} = G_{23} = 0$$

$$Q_{12} = \mu_{21}E_{11}$$

$$\text{or } = \mu_{12}E_{22} = (.29)(14.178)(10^6) = 4.11(10^6)$$

$$G_{12} = Q_{12}/1 - \mu_{12}\mu_{21} = 4.47(10^6)$$

$$G_{33} = G_{xy} = 4.93(10^6)$$

(b) Orthogonal Case (Case 2)

Areas 3 and 4 (MAT2 (3)(4)) analyses were as follows:

Analysis Case 2 consists of a 90-degree rotation of Case 1 layup and was run to permit the extrapolation of findings between the two orthogonal extremes. For this case the Table 6 (Col. A) directional properties were reversed to obtain the following: $E_{11} = 3.6(10^6)$, $E_{22} = 19.0(10^6)$, $G_{yy} = .65(10^6)$, $\mu_{12} = .0378$, and $\mu_{21} = .20$.

from which:

$$G_{11} = 3.63(10^6)$$

$$G_{22} = 19.144(10^6)$$

$$G_{12} = (.20)(3.6)(10^6)/.99244 = .725$$

$$G_{13} = G_{23} = 0$$

$$G_{33} = .65(10^6)$$

Area 2 (MAT2 (2)) analyses proceeded as follows:

By simply reversing the Case 1 modulus values, we have:

$$E_{11} = 14.74(10^6), E_{22} = 23.55(10^6)$$

$$G_{xy} = 4.92(10^6)$$

$$\mu_{21} = 0.2881 \text{ (from SQ5 reverse)}$$

From this then:

$$G_{11} = 15.54(10^6) \text{ and } G_{22} = 24.84(10^6)$$

$$Q_{12} = (0.288)(14.74) = 4.245(10^6)$$

$$G_{12} = Q_{12}/1-\mu_{12}\mu_{21} = 4.47(10^6)$$

$$G_{13} = G_{23} = 0$$

$$G_{33} = G_{xy} = 4.93(10^6)$$

(2) MAT2 Input Summary (Cases 1 and 2)

All of the G values generated for Cases 1 and 2 as input into the NASTRAN bulk data set is summarized in Table 7.

TABLE 7

"MAT2" SUMMARY CASES 1 AND 2

VARIABLE & COLUMN	MAT2 1-8	MID 9-16	G ₁₁ 17-24	G ₁₂ 25-32	G ₁₃ 33-40	G ₂₂ 41-48	G ₂₃ 49-56	G ₃₃ 57-64	RHØ 65-72
ANALYSIS CASE NO.1	MAT2	2	24.84+6	4.47+6	-	15.54+6	-	4.93+6	.146
	MAT2	3	19.14+6	.72+6	-	3.63+6	-	.65+6	.056
	MAT2	4	19.14+6	.72+6	-	3.63+6	-	.65+6	.056
ANALYSIS CASE NO.2	MAT2	2	15.54+6	4 +6	-	24.84+6	-	4.93+6	.146
	MAT2	3	3.63+6	.72+6	-	19.14+6	-	.65+6	.056
	MAT2	4	3.63+6	.72+6	-	19.14+6	-	.65+6	.056

(3) MAT2 Input Summary (Cases 1 through 10)

Following the above procedure a complete derivation of all MAT2 input requirements was then made. The first step of this summary was to run all of the SQ5 runs required to derive the laminate properties for the 40/60 steel-to-composite section of the vane. Table 8 summarizes all of the values extracted from each of the SQ5 runs.

The next step was to directionally correct the Table 8 values by means of Equations 5a through 5g into a set of G values for each laminate noted in Table 8. The results of this conversion are noted in Table 9. The resulting Table 9 values were expanded to the orthogonal sets and all of the required Area 2 input values were derived for Cases 1 through 8, as noted in Table 10. Also contained within Tables 9 and 10 are the associated values for analysis Cases 9 and 10. Input for these cases will be discussed in the next section.

TABLE 8
SQ5 PROPERTIES FOR 40/60 STEEL COMPOSITE BOOT AREA, USING 5 DIFFERENT
COMPOSITE INSERTS

LAYUP PROP.	HS-FIBER [0 _g , 90] _s	HM-FIBER (0 _g , 90) _s	HS-FIBER (+45) _s	SPEC.FIBER (+45) _s	21 KSI AS-FIBER (0 ₃ , +45, 90) _s
E _x	23.55	25.73	14.10	14.31	19.44
E _y	14.74	15.03	14.10	14.31	15.88
G _{xy}	4.93	4.93	7.85	8.42	5.90
M _x	.288	.289	.429	.450	.316
* M _y	.180	.169	.429	.450	.258
1-M _x M _y	.948	.951	.816	.798	.918

(*Derived via Equation 3)

The next step in the MAT2 summarization is the definition of the G matrix for vane areas 3 and 4. This was done through the use of the base Equations 1 and 4. From these equations and data established in Table 6 the summarized results noted in Table 11 for areas 3 and 4 were obtained.

TABLE 9

"MAT2" INPUT G VALUE AND ASSOCIATED EQUATIONS ($\times 10^6$)

LAYUP PROP	HS-FIBER [0 _g ,90]s	HM-FIBER [0 _g ,90]s	HS-FIBER [+45]s	SPEC-FIBER [+45]s	21 KSI AS-FIBER [0 ₃ , +45, 90]s
G ₁₁	24.84	27.05	17.28	17.93	21.18
G ₂₂	15.54	15.80	17.28	17.93	17.30
G ₁₂	4.47	4.57	7.41	8.07	5.46
G ₁₃	0	0	0	0	0
G ₂₃	0	0	0	0	0
G ₃₃	4.93	4.93	7.85	8.42	5.90

$$G_{11} = \frac{E_y}{1 - \mu_{12}\mu_{21}} \quad (\text{From Equation 4}) \quad (5a)$$

$$\mu_x E_y = \mu_y E_x \text{ or } \mu_{12} E_{22} = \mu_{21} E_{11} \quad (5b)$$

$$M_{21} = \frac{\mu_{12} E_{22}}{E_{11}} = \frac{\mu_x E_y}{E_x} \quad (\text{From Equation 3}) \quad (5c)$$

$$G_{22} = \frac{E_y}{1 - \mu_x \mu_y} \quad (5d)$$

$$G_{12} = \frac{21 E_{11}}{1 - \mu_x \mu_y} = \frac{\mu_y E_x}{1 - \mu_x \mu_y} \quad (5e)$$

$$G_{13} = G_{23} = 0 \quad (5f)$$

$$G_{33} = G_{xy} \quad (5g)$$

TABLE 10
SUMMARIZED MAT2 VALUES FOR VANE AREA NO. 2

COL. CASE	1-8	9-16	G ₁₁ 17-24	G ₁₂ 25-32	G ₁₃ 33-40	G ₂ 41-48	G ₂₃ 49-56	G ₃₃ 57-64	RHØ 65-72
1	MAT2	2	24.84+6	4.47+6	-	15.54+6	-	4.93+6	.146
2	MAT2	2	15.54+6	4.47+6	-	24.84+6	-	4.93+6	.146
3	MAT2	2	17.28+6	7.41+6	-	17.28+6	-	7.85+6	.146
4	MAT2	2	27.05+6	4.57+6	-	15.80+6	-	4.93+6	.146
5	MAT2	2	15.80+6	4.57+6	-	27.05+6	-	4.93+6	.146
6	MAT2	2	17.93+6	8.07+6	-	17.93+6	-	8.42+6	.146
7	MAT2	2	21.18+6	5.46+6	-	17.30+6	-	5.90+6	.146
8	MAT2	2	17.30+6	5.46+6	-	21.18+6	-	5.90+6	.146
CHOP	MAT2	2	20.05+6	5.99+6	-	20.05+6	-	7.74+6	.146
EASE	MAT2	2	15.12+6	3.67+6	-	15.12+6	-	5.60+6	.152

TABLE 11
 VANE AREAS NO. 3 AND NO. 4 "MAT2" DATA INPUT

COL. CASE	1-8	9-16	G ₁₁ 17-24	G ₁₂ 25-32	G ₁₃ 33-40	G ₂₂ 41-48	G ₂₃ 49-56	G ₃₃ 57-64	RHØ 65-72
1	MAT2	↑	19.14	.724	-	3.63	-	.65	.056
2	MAT2	↑	3.63	.726	-	19.14	-	.65	.056
3	MAT2	(-)	6.53	5.23	-	6.53	-	5.52	.056
4	MAT2	↑	22.88	1.077	-	4.15	-	.65	.056
5	MAT2	≈	4.15	1.079	-	22.88	-	.65	.056
6	MAT2	0	3.45	2.86	-	3.45	-	6.46	.056
7	MAT2	≈	12.98	1.970	-	6.53	-	2.27	.056
8	MAT2	↑	6.53	1.980	-	12.98	-	2.27	.056
CHOP	MAT2	↑	14.815	4.415	-	14.815	-	5.20	.056
BASE	MAT2	↓	3.797	1.063	-	3.797	-	1.367	.066

(1) - 3 or 4, depending on area

(a) Analysis Cases 9 and 10

As noted in Tables 10 and 11, values for two additional cases were tabulated. These involved the chopped-graphite case (Case 9) and MAT2 basepoint run (Case 10). Each of these cases could have been simplified to MAT1 NASTRAN input, but were MAT2 input. Case 9 was input this way for program input/output consistency. Case 10, however, was included for correlation to a NASTRAN run, using MAT1 data cards. For this correlation the MAT2 values (G_{11} , G_{12} , G_{13} , G_{22} , G_{23} , and G_{33}) were generated through the equations which effectively degenerated the MAT2 data to MAT1 data within NASTRAN. Correlation was excellent (less than 1% error) between the two runs, indicating a high level of confidence in the MAT2 input. The comparative results for the Case 10 correlation were noted back in Table 5. New-data Cases 9 and 10 input values for Tables 10 and 11 were derived through Equations 1 and 4 and the data contained in Table 6, whereby orthotropic properties were degenerated by setting $E_{11} = E_{22}$. The shear was computed simply by: $G_{xy} = E/2(1+\mu)$ with $\mu = \mu_{12} = \mu_{21}$.

(b) Analysis MAT2 Input Summary For Cases 1 Through 10

The final step in the MAT2 summarization was to combine all of the data from previous tables into a summary table for each of the 10 analysis cases. This combination is noted in Table 12 where all of the data is ordered and set up as to the actual input format required by NASTRAN.

2. PART II (AXLE AND BOOT ELIMINATION)

The second part of the analysis consisted of eliminating both vane axles and the end boots (Figure 4). These design changes (denoted as FDL-1 and FDL-2) were effected quite simply through property changes to those elements representing the axle or boot portions of the model.

TABLE 12
 NASTRAN INPUT SUMMARY FOR ANALYSIS CASES NO. 1 THROUGH 10

VARIABLE & COLUMN	MAT2 1-8	MID 9-16	G11 17-24	G12 25-32	G13 33-40	G22 41-48	G23 49-56	G33 57-64	RHO 65-72
ANALYSIS CASE No. 1	MAT2 MAT2 MAT2	2 3 4	24.84+6 19.14+6 19.14+6	4.47+6 .72+6 .72+6	- - -	15.54+6 3.63+6 3.63+6	- - -	4.93+6 .65+6 .65+6	.146 .056 .056
ANALYSIS CASE No. 2	MAT2 MAT2 MAT2	2 3 4	15.54+6 3.63+6 3.63+6	4.47+6 .73+6 .73+6	- - -	24.84+6 19.14+6 19.14+6	- - -	4.93+6 .65+6 .65+6	.146 .056 .056
ANALYSIS CASE No. 3	MAT2 MAT2 MAT2	2 3 4	17.28+6 6.53+6 6.53+6	7.41+6 5.23+6 5.23+6	- - -	6.53+6 6.53+6 6.53+6	- - -	7.85+6 5.52+6 5.52+6	.146 .056 .056
ANALYSIS CASE No. 4	MAT2 MAT2 MAT2	2 3 4	27.05+6 22.88+6 22.88+6	4.57+6 1.08+6 1.08+6	- - -	15.80+6 4.15+6 4.15+6	- - -	4.93+6 .65+6 .65+6	.146 .056 .056
ANALYSIS CASE No. 5	MAT2 MAT2 MAT2	2 3 4	15.80+6 4.15+6 4.15+6	4.57+6 1.08+6 1.08+6	- - -	27.05+6 22.88+6 22.88+6	- - -	4.93+6 .65+6 .65+6	.146 .056 .056
ANALYSIS CASE No. 6	MAT2 MAT2 MAT2	2 3 4	17.93+6 3.45+6 3.45+6	8.07+6 2.86+6 2.86+6	- - -	17.93+6 3.45+6 3.45+6	- - -	8.42+6 6.46+6 6.46+6	.146 .056 .056
ANALYSIS CASE No. 7	MAT2 MAT2 MAT2	2 3 4	21.18+6 12.98+6 12.98+6	5.46+6 1.97+6 1.97+6	- - -	17.30+6 6.53+6 6.53+6	- - -	5.90+6 2.27+6 2.27+6	.146 .056 .056
ANALYSIS CASE No. 8	MAT2 MAT2 MAT2	2 3 4	17.30+6 6.53+6 6.53+6	5.46+6 1.98+6 1.98+6	- - -	21.18+6 12.98+6 12.98+6	- - -	5.90+6 2.27+6 2.27+6	.146 .056 .056
CHOPPED GRAPHITE CASE	MAT2 MAT2 MAT2	2 3 4	20.05+6 14.82+6 14.82+6	5.99+6 4.42+6 4.42+6	- - -	20.05+6 14.82+6 14.82+6	- - -	7.74+6 5.20+6 5.20+6	.146 .056 .056
BASELINE CASE	MAT2 MAT2 MAT2	2 3 4	15.12+6 3.80+6 3.80+6	3.67+6 1.06+6 1.06+6	- - -	15.12+6 3.80+6 3.80+6	- - -	5.60+6 1.37+6 1.37+6	.152 .066 .066

(For Boot Area PID = 2) 60% = composite 40% = steel)

a. Axle Removal (FDL-1)

Within the advanced composite (Part I) model the axles are represented by 7th and 8th (Areas 7 and 8, Figure 14) MAT items in the MAT data set. For these items, the modulus and density properties were assigned insignificant values of 3.0 and .0001, respectively. This, in effect, yields a set of axles with no weight nor stiffness, thus eliminating them from the model.

b. Boot Removal (FDL-2)

Within the Part I model, the boots are represented by the 1st and 2nd (Areas 1 and 2, Figure 14) MAT items in the MAT data set. For boot removal, the properties for these areas were simply equated to those in areas 3 and 4, which resulted in a uniform vane of one material and no boots.

3. PART III (VANE THICKNESS VARIATIONS) FDL-2-.xt

The third portion of this study consisted of changing the thickness of the two most promising designs resulting from the parts II and III studies. Here again, the model change was quite simple because the "PQUAD2" data sets controlling the thickness values in Areas 1 through 4 (Figure 14) were all that needed revision. The specific analysis consisted of reducing the thickness to 70%, 60%, 50%, and 40% of the basepoint thickness values carried in Parts I and II.

4. PARTS I, II, AND III SUMMARY

A complete summary of all revisions to the NASTRAN program required for the analysis is noted in Table 13. The data contained in this table was generated from the actual NASTRAN changes for each of the 22 computer runs comprising the analysis conducted in this report. Typically, the data supplied in Table 13 were the only changes made to the NASTRAN program noted in Appendix C.

TABLE 13

ACTUAL NASTRAN INPUT CHANGES

a. Analysis Cases 1 Through 10

TITLE=K.P.SCHWARTZ, ANALYSIS #1 (0 DEG. LAYERS=9, 90 DEG. LAYERS=1) HS						
MAT2	2	24.84+6	4.47+6	15.54+6	4.93+6	.146
MAT2	3	19.14+6	.72+6	3.63+6	.65+6	.056
MAT2	4	19.14+6	.72+6	3.63+6	.65+6	.055
TITLE=K.P.SCHWARTZ, ANALYSIS #2 (0 DEG. LAYERS=1, 90 DEG. LAYERS=9) HS						
MAT2	2	15.54+6	4.47+6	24.84+6	4.93+6	.146
MAT2	3	3.63+6	.73+6	19.14+6	.65+6	.056
MAT2	4	3.63+6	.73+6	19.14+6	.65+6	.056
TITLE=K.P.SCHWARTZ, ANALYSIS #3 (ALTERNATING +45,-45 DEG. LAYERS) HS						
MAT2	2	17.28+6	7.41+6	17.28+6	7.85+6	.146
MAT2	3	6.53+6	5.23+6	6.53+6	5.52+6	.055
MAT2	4	6.53+6	5.23+6	6.53+6	5.52+6	.055
TITLE=K.P.SCHWARTZ, ANALYSIS #4 (0 DEG. LAYERS=9, 90 DEG. LAYERS=1) HM						
MAT2	2	27.05+6	4.57+6	15.80+6	4.93+6	.146
MAT2	3	22.88+6	1.08+6	4.15+6	.65+6	.056
MAT2	4	22.88+6	1.08+6	4.15+6	.65+6	.055
TITLE=K.P.SCHWARTZ, ANALYSIS #5 (0 DEG. LAYERS=1, 90 DEG. LAYERS=9) HM						
MAT2	2	15.80+6	4.57+6	27.05+6	4.93+6	.146
MAT2	3	4.15+6	1.08+6	22.88+6	.65+6	.056
MAT2	4	4.15+6	1.08+6	22.88+6	.65+6	.056
TITLE=K.P.SCHWARTZ, ANALYSIS #6 (ALTERNATING +45,-45 DEG. LAYERS) HM						
MAT2	2	17.93+6	8.07+6	17.93+6	8.42+6	.146
MAT2	3	3.45+6	2.86+6	3.45+6	6.46+6	.056
MAT2	4	3.45+6	2.86+6	3.45+6	6.46+6	.056
TITLE=K.P.SCHWARTZ, ANALYSIS #7 (0 DEG.=3,+45,-45,90 DEG. LAYERS) AS						
MAT2	2	21.18+6	5.46+6	17.30+6	5.90+6	.146
MAT2	3	12.98+6	1.97+6	6.53+6	2.27+6	.056
MAT2	4	12.98+6	1.97+6	6.53+6	2.27+6	.056
TITLE=K.P.SCHWARTZ, ANALYSIS #8 (90 DEG.=3,+45,-45, 0 DEG. LAYERS) AS						
MAT2	2	17.30+6	5.46+6	21.18+6	5.90+6	.146
MAT2	3	6.53+6	1.98+6	12.98+6	2.27+6	.056
MAT2	4	6.53+6	1.98+6	12.98+6	2.27+6	.056
TITLE=K.P.SCHWARTZ, ANALYSIS #9 (CHOPPED GRAPHITE MATERIAL)						
MAT2	2	20.05+6	5.99+6	20.05+6	7.74+6	.146
MAT2	3	14.82+6	4.42+6	14.82+6	5.20+6	.055
MAT2	4	14.82+6	4.42+6	14.82+6	5.20+6	.056
TITLE=K.P.SCHWARTZ, ANALYSIS #10 (GRAPHITE COMPACT MATERIAL)						
MAT2	2	15.12+6	3.67+6	15.12+6	5.60+6	.152
MAT2	3	3.80+6	1.06+6	3.80+6	1.37+6	.056
MAT2	4	3.80+6	1.06+6	3.80+6	1.37+6	.066

TABLE 13 (CONT'D)
 ACTUAL NASTRAN INPUT CHANGES
 b. Analysis Cases 7A Through 7D

TITLE=K.P.SCHWARTZ, NO AXLES #7 (0 DEG.=3,+45,-45,90 DEG. LAYERS) AS							
MAT2	2	21.18+6	5.46+6	17.30+6	5.90+6	.146	
MAT2	3	12.98+6	1.97+6	6.53+6	2.27+6	.056	
MAT2	4	12.98+6	1.97+6	6.53+6	2.27+6	.056	
MAT1	7	3.0E0		.3200	.0001		
MAT1	8	3.0E0		.3200	.0001		
TITLE=K.P.SCHWARTZ, NO BOOTS #7B (0 DEG.=3,+45,-45,90 DEG. LAYERS) AS							
MAT2	1	12.98+6	1.97+6	6.53+6	2.27+6	.056	
MAT2	2	12.98+6	1.97+6	6.53+6	2.27+6	.056	
MAT2	3	12.98+6	1.97+6	6.53+6	2.27+6	.056	
MAT2	4	12.98+6	1.97+6	6.53+6	2.27+6	.056	
MAT1	7	3.0E0		.3200	.0001		
MAT1	8	3.0E0		.3200	.0001		
TITLE=K.P.SCHWARTZ, 70% SIZE #7C (0 DEG.=3,+45,-45,90 DEG. LAYERS) AS							
PQUAD2	1	1	.2620				
PQUAD2	2	2	.2620				
PQUAD2	3	3	.2620				
PQUAD2	4	4	.2620				
MAT2	1	12.98+6	1.97+6	6.53+6	2.27+6	.056	
MAT2	2	12.98+6	1.97+6	6.53+6	2.27+6	.056	
MAT2	3	12.98+6	1.97+6	6.53+6	2.27+6	.056	
MAT2	4	12.98+6	1.97+6	6.53+6	2.27+6	.056	
MAT1	7	3.0E0		.3200	.0001		
MAT1	8	3.0E0		.3200	.0001		
TITLE=K.P.SCHWARTZ, 60% SIZE #7D (0 DEG.=3,+45,-45,90 DEG. LAYERS) AS							
PQUAD2	1	1	.2240				
PQUAD2	2	2	.2240				
PQUAD2	3	3	.2240				
PQUAD2	4	4	.2240				
MAT2	1	12.98+6	1.97+6	6.53+6	2.27+6	.056	
MAT2	2	12.98+6	1.97+6	6.53+6	2.27+6	.056	
MAT2	3	12.98+6	1.97+6	6.53+6	2.27+6	.056	
MAT2	4	12.98+6	1.97+6	6.53+6	2.27+6	.056	
MAT1	7	3.0E0		.3200	.0001		
MAT1	8	3.0E0		.3200	.0001		

c. Analysis Cases 7E and 7F

TITLE=K.P.SCHWARTZ, 50% SIZE #7E (0 DEG.=3,+45,-45,90 DEG. LAYERS) AS							
PQUAD2	1	1	.1870				
PQUAD2	2	2	.1870				
PQUAD2	3	3	.1870				
PQUAD2	4	4	.1870				
MAT2	1	12.98+6	1.97+6	6.53+6	2.27+6	.056	
MAT2	2	12.98+6	1.97+6	6.53+6	2.27+6	.056	
MAT2	3	12.98+6	1.97+6	6.53+6	2.27+6	.056	
MAT2	4	12.98+6	1.97+6	6.53+6	2.27+6	.056	
MAT1	7	3.0E0		.3200	.0001		
MAT1	8	3.0E0		.3200	.0001		
TITLE=K.P.SCHWARTZ, 40% SIZE #7F (0 DEG.=3,+45,-45,90 DEG. LAYERS) AS							
PQUAD2	1	1	.1500				
PQUAD2	2	2	.1500				
PQUAD2	3	3	.1500				
PQUAD2	4	4	.1500				
MAT2	1	12.98+6	1.97+6	6.53+6	2.27+6	.056	
MAT2	2	12.98+6	1.97+6	6.53+6	2.27+6	.056	
MAT2	3	12.98+6	1.97+6	6.53+6	2.27+6	.056	
MAT2	4	12.98+6	1.97+6	6.53+6	2.27+6	.056	
MAT1	7	3.0E0		.3200	.0001		
MAT1	8	3.0E0		.3200	.0001		

TABLE 13 (CONT'D)
 ACTUAL NASTRAN INPUT CHANGES
 d. Analysis Cases 9A Through 9D

TITLE=K.P.SCHWARTZ, NO AXLES #9 (CHOPPED GRAPHITE MATERIAL)						
MAT2	2	20.05+6	5.99+6	20.05+6	7.74+6	.146
MAT2	3	14.82+6	4.42+6	14.82+6	5.20+6	.056
MAT2	4	14.82+6	4.42+6	14.82+6	5.20+6	.056
MAT1	7	3.0E0		.3200	.0001	
MAT1	8	3.0E0		.3200	.0001	
TITLE=K.P.SCHWARTZ, NO ROOTS #9A (CHOPPED GRAPHITE MATERIAL)						
MAT2	1	14.82+6	4.42+6	14.82+6	5.20+6	.056
MAT2	2	14.82+6	4.42+6	14.82+6	5.20+6	.056
MAT2	3	14.82+6	4.42+6	14.82+6	5.20+6	.056
MAT2	4	14.82+6	4.42+6	14.82+6	5.20+6	.056
MAT1	7	3.0E0		.3200	.0001	
MAT1	8	3.0E0		.3200	.0001	
TITLE=K.P.SCHWARTZ, 70% SIZE #9C (CHOPPED GRAPHITE MATERIAL)						
PQUAD2	1	1	.2620			
PQUAD2	2	2	.2620			
PQUAD2	3	3	.2620			
PQUAD2	4	4	.2620			
MAT2	1	14.82+6	4.42+6	14.82+6	5.20+6	.056
MAT2	2	14.82+6	4.42+6	14.82+6	5.20+6	.056
MAT2	3	14.82+6	4.42+6	14.82+6	5.20+6	.056
MAT2	4	14.82+6	4.42+6	14.82+6	5.20+6	.056
MAT1	7	3.0E0		.3200	.0001	
MAT1	8	3.0E0		.3200	.0001	
TITLE=K.P.SCHWARTZ, 50% SIZE #9D (CHOPPED GRAPHITE MATERIAL)						
PQUAD2	1	1	.2240			
PQUAD2	2	2	.2240			
PQUAD2	3	3	.2240			
PQUAD2	4	4	.2240			
MAT2	1	14.82+6	4.42+6	14.82+6	5.20+6	.056
MAT2	2	14.82+6	4.42+6	14.82+6	5.20+6	.056
MAT2	3	14.82+6	4.42+6	14.82+6	5.20+6	.056
MAT2	4	14.82+6	4.42+6	14.82+6	5.20+6	.056
MAT1	7	3.0E0		.3200	.0001	
MAT1	8	3.0E0		.3200	.0001	

e. Analysis Cases 9E and 9F

TITLE=K.P.SCHWARTZ, 50% SIZE #9E (CHOPPED GRAPHITE MATERIAL)						
PQUAD2	1	1	.1870			
PQUAD2	2	2	.1870			
PQUAD2	3	3	.1870			
PQUAD2	4	4	.1870			
MAT2	1	14.82+6	4.42+6	14.82+6	5.20+6	.056
MAT2	2	14.82+6	4.42+6	14.82+6	5.20+6	.056
MAT2	3	14.82+6	4.42+6	14.82+6	5.20+6	.056
MAT2	4	14.82+6	4.42+6	14.82+6	5.20+6	.056
MAT1	7	3.0E0		.3200	.0001	
MAT1	8	3.0E0		.3200	.0001	
TITLE=K.P.SCHWARTZ, 40% SIZE #9F (CHOPPED GRAPHITE MATERIAL)						
PQUAD2	1	1	.1500			
PQUAD2	2	2	.1500			
PQUAD2	3	3	.1500			
PQUAD2	4	4	.1500			
MAT2	1	14.82+6	4.42+6	14.82+6	5.20+6	.056
MAT2	2	14.82+6	4.42+6	14.82+6	5.20+6	.056
MAT2	3	14.82+6	4.42+6	14.82+6	5.20+6	.056
MAT2	4	14.82+6	4.42+6	14.82+6	5.20+6	.056
MAT1	7	3.0E0		.3200	.0001	
MAT1	8	3.0E0		.3200	.0001	

SECTION V
VANE ANALYSIS

The overall analysis consists of a total of 22 NASTRAN runs summarized in Table 14. The first of these runs consists of a single baseline run (Case 10, Table 14) representing the current ROVAC vane. The next series of runs consists of nine surveys (Cases 1 through 9, Table 14) investigating several different layups and fiber types with which a ROVAC vane could be constructed. Two of the nine cases were selected as the most promising for further analysis.

The specific cases selected for further study were Cases 7 and 9, primarily due to the minimal tip deflections experienced with these two designs. The additional analysis consisted of first removing the axles from the vane (subcase A) and secondly removing both the axles and boots from the vane (subcase B). These cases are referred to as design types FDL-1 and FDL-2, respectively, and are noted as test cases 7A, 7B, 9A, and 9B in Table 14.

Following the axle and boot removal, subcases C, D, E, and F were run on FDL-2 design and consisted of thinning the FDL-2 design to .7, .6, .5, and .4, of the original thickness. These cases are referred to by their thickness value (t) added to the design type designation. The actual analysis cases are noted as test cases 7C through 7F and 9E through 9F. An additional designation (CG) has also been added to the design type to distinguish the chopped-graphite material from the layup type structures of Case 7.

Within the analysis, the NASTRAN case control program (Appendix C, Pg 120) was written to yield node point displacements, load vectors, single point constraint forces, quadrilateral and bar element forces, and quadrilateral and bar element stresses. In addition to this tabular output, two plots consisting of single and superimposed deflected shapes were also programmed.

TABLE 14
SUMMARY OF ALL CASES AND DESIGN VARIATIONS ANALYZED

TEST CASE	CDC RUN DESIGNATION	LAYUP STRUCTURE	FIBER TYPE	DESIGN TYPE	TEST CASE	CDC RUN DESIG.	LAYUP STRUCTURE	FIBER TYPE	DESIGN TYPE
1	W71/00QA	9(0°), 1(90°)	HS	ROVAC	7B	W7C/008L	Ref. Case 7	AS	FDL-2
2	W72/00GN	1(0°), 9(90°)	HS	ROVAC	7C	W7E/004P	Ref. Case 7	AS	FDL-2-.7t
3	W73/0087	+45°, -45°	HS	ROVAC	7D	W7G/008S	Ref. Case 7	AS	FLD-2-.6t
4	W74/000B	9(0°), 1(90°)	HM	ROVAC	7E	W7I/AEK3	Ref. Case 7	AS	FDL-2-.5t
5	W75/0007	1(0°), 9(90°)	HM	ROVAC	7F	W7K/AEKV	Ref. Case 7	AS	FDL-2-.4t
6	W76/00HI	+45°, -45°	Special	ROVAC	9A	W7B/006S	Ref. Case 9	-	FDL-1 (CG)
7	W77/00HB	3(0°), +45°, -45°, 1(90°)	AS	ROVAC	9B	W7D/0009	Ref. Case 9	-	FDL-2 (CG)
8	W78/00DE	3(90°), +45°, -45°, 1(0°)	AS	ROVAC	9C	W7F/0040	Ref. Case 9	-	FDL-2-7t (CG)
9	W79/00DX	CHOPPED GRAPHITE	-	ROVAC	9D	W7H/008R	Ref. Case 9	-	FDL-2-.6t (CG)
10	W70/00GL	COMPACT GRAPHITE	-	ROVAC	9E	W7J/AEK1	Ref. Case 9	-	FDL-2-.5t (CG)
7A	W7A/0078	Ref. Case 7	AS	FDL-1	9F	W7L/AELD	Ref. Case 9	-	FDL-2-.4t (CG)

FDL-1 = axles removed from basic ROVAC design.
 FDL-2 = axles and boots removed from basic ROVAC design.
 t = basic ROVAC vane thickness.

1. PART I ANALYSIS AND DISCUSSION

Actual data extracted from the NASTRAN output was limited to six primary deflections, the ten highest stresses in the vane itself, and the resulting bearing loads and the vane weight. The six primary deflections of interest are noted in Figure 15. Actual quantitative deflection values (Figure 15) for Cases 1 through 10 are included in Table 15, along with vane weight and resulting bearing loads. For this analysis and the following Part II and III studies, deflection, load, and weight data were extracted as follows:

Deflection: A = T1 or X deflection @ Node point 1
B = T2 or Y deflection @ Node point 1
C = T2 or Y deflection @ Node point 28
D = T2 or Y deflection @ Node point 309
E = T2 or Y deflection @ Node point 476

Bearing Load: Summation of T2 SPC forces at node points 477, 478, 479, and 480.

Vane Weight: 2X mass noted in grid point weight generator.

Element and

Nodal Locations: Refer to pages 101, 102, 103, Appendix B.

The resultant stress data is noted in Tables 16a and 16b. This tabulation notes the ten highest stresses occurring in the vane. All of the stresses noted in Table 16 occur in either the vane boot region or the vane closeout structure. In view of this fact, Tables 17a and 17b are also included, in which is related detailed stress data as restricted to the composite portion of the vane only.

For the most part, the data presented in Tables 15, 16, and 17 is self-explanatory. Tip deflection for cases 1 through 9 ranged from .93 mils to 3.74 mils, as compared to the basepoint ROVAC value of 2.91 mils. It may be well to note that this 2.91 basepoint value compares favorably with an estimated 3.0 value assessed in an AFFDL

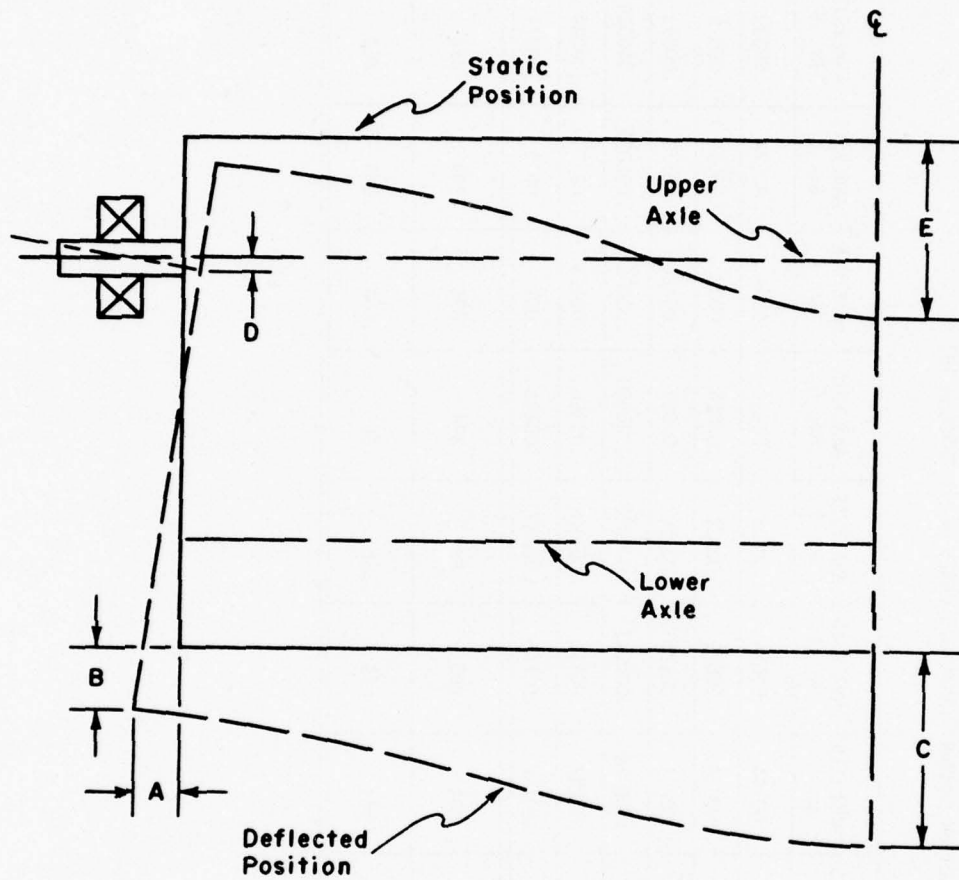

(Reference Tables 15, 18, 21, and 22)

Figure 15. Tabulated Deflections, Positions A Through E

TABLE 15
LOAD/DEFLECTION SUMMARY (ANALYSIS CASES NO. 1 THROUGH 10)

FIG. DEFLECTION VALUE	BASELINE No. 10	ANALYSIS No. 1	ANALYSIS No. 2	ANALYSIS No. 3	ANALYSIS No. 4	ANALYSIS No. 5	ANALYSIS No. 6	ANALYSIS No. 7	ANALYSIS No. 8	ANALYSIS No. 9
A	.00134	.00029	.00116	.00144	.00024	.00105	.00224	.0004	.00074	.00037
B	.000256	.00019	.00022	.00024	.00019	.00021	.00026	.0002	.0002	.00019
C	.00291	.00193	.00324	.00221	.00185	.00310	.00309	.00120	.00170	.00093
D	.0000707	.000048	.000063	.000068	.000047	.000062	.000080	.000050	.000056	.000029
E	.00298	.00193	.00326	.00247	.00185	.00310	.00356	.00123	.0017	.00094
C-B	.00157	.00174	.00302	.00197	.00166	.00289	.00283	.001	.0015	.00074
(LBS.) BEARING LOAD	975	895	894	894	895	894	894	894	894	894
VANE WEIGHT (LBS)	.942	.864	.864	.864	.864	.864	.864	.864	.864	.864

TABLE 16

MAXIMUM PRINCIPAL STRESS SUMMARY REFLECTING THE TOP TEN STRESS VALUES

a. Analysis Cases 1 Through 4 and Baseline

BASELINE		ANALYSIS No. 1		ANALYSIS No. 2		ANALYSIS No. 3		ANALYSIS No. 4	
ELEMENT	STRESS	ELEMENT	STRESS	ELEMENT	STRESS	ELEMENT	STRESS	ELEMENT	STRESS
163	3035	163	2465	246	3031	163	2861	163	2426
190	4679	190	4158	190	3921	190	4023	190	4093
191	3908	191	3553	191	3254	191	3223	191	3501
217	3887	215	3773	217	3397	217	3115	217	3728
218	3906	218	3670	218	3351	218	3118	218	3626
244	4931	244	5111	244	4402	244	3805	244	5070
245	4838	245	4275	245	4206	245	3937	245	4219
271	8608	271	6241	271	7697	271	7649	271	6086
272	7004	272	4468	272	6212	272	6405	272	4334
273	3160	164	2594	273	3110	273	3240	164	2554

Stress in PSI

b. Cases 5 Through 9

ANALYSIS No. 5		ANALYSIS No. 6		ANALYSIS No. 7		ANALYSIS No. 8		ANALYSIS No. 9	
ELEMENT	STRESS	ELEMENT	STRESS	ELEMENT	STRESS	ELEMENT	STRESS	ELEMENT	STRESS
246	3152	163	2975	163	2462	163	2395	244	4572
190	3863	190	3969	190	3917	190	3800	190	3571
191	3208	191	3101	191	3346	191	3208	191	3038
217	3399	217	2821	217	3504	217	3348	217	3240
218	3336	218	2870	218	3492	218	3349	218	3249
244	4458	244	3209	245	4204	245	4147	245	4027
245	4182	245	3772	246	2515	246	2749	246	2668
271	7564	271	8269	271	6436	271	6985	271	6259
272	6039	272	7356	272	4780	272	5435	272	4688
273	3122	273	3670	164	2480	273	2927	273	2617

Stress in PSI

TABLE 17
COMPOSITE REGION STRESS SUMMARY
a. Analysis Cases 1 Through 10

	ELEMENT	NORMAL X	NORMAL Y	SHEAR XY	MAJOR PRINCIPAL	ANGLE α	MAX. SHEAR
BASELINE (No. 10)	*						
	27	1875	13.1	-4.5	1875	-.14	931
	81	1586	44.8	-15.4	1586	-.57	770
	**						
	227	450	97.0	745	1039	-38.34	765
	254	414	22.7	704	949	-37.22	730
281	321	-74.2	-569	726	-35.43	602	
308	240	-111.7	-411	511	-33.42	447	
ANALYSIS No. 1	*						
	27	2313	8.95	5.28	2313	-.13	1152
	81	1558	35.4	14.2	1558	-.54	761
	**						
	227	435	0	-556	815	-34.34	597
	254	363	-67.5	-507	700	-33.49	552
281	178	-131	-398	451	-34.36	427	
308	-115	-113	-325	211	-45.09	325	
ANALYSIS No. 2	*						
	27	1684	10.63	3.8	1684	-.13	837
	81	1366	39.32	-13.70	1366	-.59	663
	**						
	227	367	-137	-559	728	-32.84	613
	254	306	-352	-511	585	-28.60	608
281	203	-642	-415	373	-22.23	592	
308	124	-486	-306	251	-22.54	432	
ANALYSIS No. 3	*						
	27	1386	18.88	-4.9	1386	-.21	683
	81	1225	43.81	-14.63	1226	-.71	591
	**						
	227	439	299	-730	1103	-42.25	734
	254	443	282	-726	1093	-41.84	730
281	386	211	-631	936	-41.04	637	
308	322	152	-494	738	-40.12	502	
ANALYSIS No. 4	*						
	27	2373	8.82	-5.52	2373	-.14	1182
	81	1548	34.78	-14.45	1549	-.55	756
	**						
	227	439	9.07	-553	817	-34.35	593
	254	369	-63.8	-505	702	-33.38	549
281	170	-134	-397	443	-34.55	425	
308	-147	-108	-330	203	-46.67	331	

*The two highest stress values.
**Bearing support region stress.

TABLE 17 (Cont'd)
 COMPOSITE REGION STRESS SUMMARY
 b. Analysis Cases 5 Through 9

	ELEMENT	NORMAL X	NORMAL Y	SHEAR XY	MAJOR PRINCIPAL	ANGLE α	MAX. SHEAR	
ANALYSIS No. 5	*	27	1741	10.84	-3.86	1741	-.13	865
		81	1402	39.48	-13.56	1402	-.57	681
	**	227	376	-175	-556	721	-31.81	621
		254	312	-412	-507	572	-27.22	623
		281	199	-722	-411	356	-20.87	617
	308	110	-524	-304	231	-21.89	438	
ANALYSIS No. 6	*	27	1008	21.54	6.95	1008	-.404	493
		81	902	40.74	19.8	903	1.31	431
	**	227	294	230	-680	944	-43.63	681
		254	325	246	-705	992	-43.40	706
		281	315	217	-639	908	-42.81	641
	308	315	195	-579	837	-42.06	582	
ANALYSIS No. 7	*	27	2007	10.36	-3.82	2007	-.11	998
		81	1637	39.14	-12.14	1637	-.44	799
	**	227	512	87.4	-674	1007	-36.25	706
		254	478	9.04	-611	899	-34.5	655
		281	349	-66.4	-474	659	-33.18	518
	308	133	-63.5	-324	374	-36.6	339	
ANALYSIS No. 8	*	27	1818	11.1	-3.52	1818	-.11	903
		81	1529	40.5	-11.93	1529	-.46	744
	**	227	480	102	-683	1001	-37.28	709
		254	449	-17	-621	880	-34.71	664
		281	347	-146	-485	645	-31.54	545
	308	213	-150	-315	396	-30.03	364	
ANALYSIS No. 9	*	27	1980	11.23	-3.54	1980	-.10	984
		81	1665	40.50	-11.36	1665	-.40	812
	**	227	579	239	-730	1160	-38.44	750
		254	549	139	-653	1029	-36.30	685
		281	415	40	-501	762	-34.73	534
	308	182	20	-316	427	-37.77	326	

*The two highest stress values.
 **Bearing support region stress.

ROVAC test effort. In general, stress for all of the design cases 1 through 9 were below that of the basepoint case. Since the composite designs of interest are far superior to the basepoint design, from a structural point of view, no further study was made relative to the resultant stresses. As noted in Table 15, vane weight was reduced from .942 lbs to .864 lbs. Due to this reduced mass, not only were the stresses reduced but the bearing load at the axle support was reduced from 975 lbs to 895 lbs.

Based primarily on the maximum tip deflection (value C, Table 15), designs from Cases 7 and 9 were selected for further study. Specifically for these cases, tip deflections were reduced from 2.91 mils to 1.20 and .93 mils. One secondary point to note is that the movement toward the compressor end plate (A, Figure 15) was also reduced by over 60%. This could very well contribute to a quieter and cooler running system due to reduced end plate forces.

Deflected shapes for all of the analysis cases (Parts I, II, and III) are included in Appendix D. These plots include the deflected shape superimposed on the original static shape. It should be noted that Appendix D figures cannot be compared to each other because NASTRAN plotting equates the maximum deflection to a specific value.

2. PART II ANALYSIS AND DISCUSSION

For the second analysis, the primary items of interest are the same as for the previous case. The overall bearing load, vane weight, and deflection summary data are noted in Table 18. Changing regions of maximum stress can be noted in Table 19 and quantitative stress data is included in Table 20. Again, element and nodal locations can be obtained by referring to Appendix B (Pages 101, 102, 103). All deflection, loads, and weight parameters are the same as in Part I.

The data has again been tabulated in a very self-explanatory manner. Tip deflections tended to increase about 14% for the FDL-1 (no axle) design. For the FDL-2 (no axle, no boot) design, additional tip deflection

TABLE 18
LOAD/DEFLECTION CHANGES DUE TO VANE REDESIGN

FIG. DEFLECTION VALUE	ANALYSIS No. 7	ANALYSIS No. 7A AXLES REMOVED	ANALYSIS No. 7B AXLES & BOOTS REMOVED	ANALYSIS No. 9	ANALYSIS No. 9A AXLES REMOVED	ANALYSIS No. 9B AXLES & BOOTS REMOVED
A	.00041	.00043	.0004	.00037	.00039	.00037
B	.0002	.00035	.00043	.00019	.00034	.00031
C	.00120	.00140	.00145	.00093	.00111	.00106
D	.00005	.0002	.00018	.000029	.00022	.00017
E	.00123	.0014	.0015	.00094	.00112	.00106
C-B	.001	.00105	.00102	.00074	.00077	.00075
BEARING LOAD (lbs)	894	801	626	894	801	626
VANE WEIGHT (lbs)	.864	.772	.608	.864	.772	.608

TABLE 19
 ELEMENT NUMBERS DENOTING THE TEN HIGHEST MAXIMUM PRINCIPAL STRESS VALUES
 FOR EACH ANALYSIS CASE

No. 7	No. 7A	No. 7B	No.7C, 7D 7E, 7F	No. 9	No. 9A	No. 9B	No.9C, 9D	No.9E, 9F
		24	24					
		25	25					25
		26	26			26	26	26
		27	27			27	27	27
163	163				163			
164	164				164			
190	190	190	190	190	190	190	190	190
191	191	191	191	191	191	191	191	191
217	217	217	217	217	217	217	217	217
218	218	218	218	218	218	218	218	218
	219				219	219	219	219
	244	244	244	244	244	244	244	244
245	245	245	245	245	245	245	245	245
246	245			246	246	246	246	
271				271				
272				272				
				273				

TABLE 20

MAXIMUM PRINCIPAL STRESS SUMMARY FOR VANE REDESIGN
(INCLUDES ALL TABLE ELEMENTS)

ANALYSIS ELEMENT	ANALYSIS			No. 9	No. 9A	No. 9B
	No. 7	No. 7A	No. 7B			
24	1900	2000	1866	1879	1973	1851
25	1954	2054	1921	1930	2023	1899
26	1989	2088	1957	1963	2055	1931
27	2007	2106	1975	1980	2071	1947
163	2462	2540	1372	2568	2331	1307
164	2480	2580	1320	2237	2326	1307
190	3917	4165	2659	3571	3793	3034
191	3346	3566	1946	3038	3250	3962
217	3504	4182	1978	3240	3904	2262
218	3492	3886	1893	3249	3677	2198
219	2183	2464	1753	2244	2564	2022
244	4810	6175	2425	4572	5965	3277
245	4204	4081	1994	4027	4010	2462
246	2515	2441	2048	2668	2597	2048
271	6436	2122	1455	6259	2085	1582
272	4780	1739	1360	4688	1784	1460
273	2404	1424	1260	2617	1493	1327

Stress Values in PSI

changes were insignificant. No appreciable change was noted over the already improved lateral movement toward the compressor end plates. In general, no appreciable changes occurred to overall deflections in either the FDL-1 and FDL-2 cases.

In removing the vane axles and boots, vane weights were reduced further to .772 and .608 lbs, thereby substantially improving the bearing load properties. In addition to the bearing load improvements, maximum principal stresses were also reduced for the most part by almost 50% for the FDL-2 case. For the FDL-1 case, a 5 to 10% increase in stress values was noted.

In summary, it can be said that removing the axles, or axles and boots, does little to degrade the basic advanced composite approach. Improvements, however, are substantial in the area of load and stress reduction, particularly for the FDL-2 case. Based on these factors, the FDL-2 design was selected for further analysis in the Part III section of this study.

3. PART III ANALYSIS

The Part III analysis consisted of defining the effects of varying thickness on the FDL-2 design selected in the previous section. Overall deflection results for this analysis are included in Table 21 (FDL-2) and Table 22 (FDL-2(CG)). Stress data is tabulated in Tables 23 and 24 for the same respective designs. The primary item to note from this analysis is that although the amount of structure is reduced substantially, the effects upon vane stresses are only minor. In addition, with the decreased structure, the resultant deflections of interest were actually improved upon slightly. The prime improvement, however, was in the area of vane-bearing loads, where values ranged from 626 lbs down to 328 lbs for a vane of 40% of the original thickness.

TABLE 21

LOAD/DEFLECTION CHANGES DUE TO VANE RESIZING (MATERIAL = 0 Deg. = 3, +45, -45, 90 Deg.) AS Type

FIG. DEFLECTION VALUE	ANAL/7B t=100%	ANAL/7C t=70%	ANAL/7D t=60%	ANAL/7E t=50%	ANAL/7F t=40%
A	.00040	.00040	.00040	.00040	.00040
B	.00043	.00038	.00036	.00035	.00033
C	.00145	.00139	.00137	.00134	.00132
D	.00018	.000145	.000131	.000117	.000103
E	.0015	.0014	.00138	.00136	.00133
C-B	.00102	.00102	.00101	.00099	.00099
BEARING LOAD (lbs)	626	477	428	379	328
VANE WEIGHT (lbs)	.608	.465	.417	.370	.323

TABLE 22

LOAD/DEFLECTION CHANGES DUE TO VANE RESIZING (MATERIAL = CHOPPED GRAPHITE)

DEFLECTION VALUE	ANAL/9B t=100%	ANAL/9C t=70%	ANAL/9D t=60%	ANAL/9E t=50%	ANAL/9F t=40%
A	.00037	.00037	.00036	.00036	.00036
B	.00031	.00026	.00024	.00023	.00021
C	.00106	.00100	.00097	.00095	.00093
D	.00017	.00017	.00012	.00011	.00010
E	.00106	.00100	.00099	.00096	.00094
C-B	.00075	.00074	.00073	.00072	.00072
BEARING LOAD (lbs)	626	477	428	379	328
VANE WEIGHT (lbs)	.608	.465	.417	.370	.323

TABLE 23

MAXIMUM PRINCIPAL STRESS SUMMARY FOR CHANGES DUE TO VANE RESIZING
(TEN HIGHEST VALUES) (MATERIAL = 0 DEG. = 3, +45, -45, 90 DEG.)

ANALYSIS ELEMENT	No. 7B	No. 7C	No. 7D	No. 7E	No. 7F
24	1866	1856	1850	1844	1835
25	1921	1910	1905	1898	1890
26	1957	1946	1940	1933	1924
27	1975	1963	1957	1951	1942
190	2659	2780	2826	2874	2922
191	1946	1991	2007	2025	2042
217	1978	1940	1923	1901	1876
218	1893	1846	1825	1800	1768
244	2425	2213	2130	2040	1938
245	1994	1870	1819	1762	1697

TABLE 24

MAXIMUM PRINCIPAL STRESS SUMMARY FOR CHANGES DUE TO VANE RESIZING
(TEN HIGHEST VALUES) (MATERIAL = CHOPPED GRAPHITE)

ANALYSIS ELEMENT	No. 9B	No. 9C	No. 9D	No. 9E	No. 9F
25	—	—	—	1874	1865
26	1931	1919	1913	1906	1896
27	1947	1935	1929	1921	1912
190	3034	2588	2651	2720	2797
191	3962	2009	2030	2053	2078
217	2262	2199	2171	2140	2100
218	2198	2129	2097	2060	2012
219	2022	1962	1934	1900	1858
244	3277	2954	2820	2671	2501
245	2462	2296	2224	2142	2047
246	2048	1949	1905	1854	1792

The primary factor to be derived from this analysis is that for this particular design an optimum design would be the thinnest vane possible. Obviously other factors come into play such as manufacturing limitations and out-of-plane considerations. Typically, these considerations would include vane bending along with the complex aspects of modeling the structure with 3-dimensional isoparametric elements.

SECTION VI
CONCLUSIONS AND RECOMMENDATIONS

1. CONCLUSIONS

The results of the programs and analysis conducted within this program has led to the following observations or conclusions:

1. For the specific design considered within the analysis (Figure 4), the existing carbon compact type material can be improved upon substantially through the use of advanced composites. These improvements can further lead to more permissive design variation for the assembly and retention of materials into a ROVAC vane structure.

2. Through the use of the advanced vane materials and structural design changes analyzed in this program, total weights and operational bearing loads were reduced by 35%. In addition, the use of advanced composites allows for a design optimization toward the thinnest structure possible from either a manufacturing or operational point of view. Specifically the analysis considered vane sizes down to 40% of original size. For the reduced thickness cases, the vane was structurally sound (in the analysis plane) and total weights and operational bearing loads were reduced by 66%. Both the 35% and 66% reductions can also be accomplished while concurrently reducing the peak vane stresses by 30% to 60%.

3. The primary objectives of the study were to reduce the amount of tip and edge deflections occurring within the vane structure. Based on the results of this study it was concluded that deflections can be significantly improved through materials and/or design variations. Within the analysis, the most significant changes occurred from the composite materials substitution. Out of the nine materials variations considered within the analysis, the two best showed tip-deflection reductions of 68% and 59%, and concurrent edge-deflection reductions of 72% and 70%, respectively. The removal of vane axles and retention boots increased

the improved deflections by approximately 20%. These increases are only minor, however, since the original materials changes would still result in 62% and 50% improvements. The effects of reducing the vane thickness were generally positive, in that due to the decrease in inertia effects, deflections actually decreased even though the structure was thinned down substantially. Actual values were only minor, however, with a maximum 9% improvement being noted in the 0.4t case.

2. RECOMMENDATIONS

Based on the results of this program, it becomes evident that further study, analysis, and testing is required to fully optimize an advanced vane configuration. In this regard, the following considerations or recommendations are offered:

a. Materials Consideration

Based on initial ground rules, the analysis discussed in this report was restricted to advanced graphite composites. These types of materials have several basic disadvantages, consisting of high friction, abrasiveness, cost, and potential corrosion inducements. In addition, from the analysis, it was noted that the primary advantages of strength were not being fully exploited. By sacrificing strength and perhaps some stiffness, the associated materials disadvantages might be offset through alternate materials choices. Alternate materials choices offering improvements in these areas include Nomex and Kevlar, both of which could readily be incorporated into a ROVAC vane structure as either a compression-molded or laid-up structure. Both materials would eliminate corrosion and cost problems at the price of reduced but, most probably, adequate strength. In addition, these materials offer further improvements in the area of weight and friction. By further reducing the strength requirement, substantial improvements could be obtained (relative to cost and friction) through the use of fiberglass and/or powdered additives to the base resin system of the vane structure. This friction improvement may contribute to the reduction of internal heat generation within the ROVAC machine.

Based upon the previous discussion, four very important recommendations can be offered.

1. A preliminary structural analysis should be conducted defining the penalties and payoff for various alternate materials. Materials to be considered should include Nomex, Kevlar, fiberglass, and woven Teflon fabrics. In addition, resin system additives and supplements should also be considered within the analysis.

2. It is recommended that the analysis discussed above be conducted by simply varying the MAT2 properties of the NASTRAN program contained in Appendix C of this report.

3. For the recommended analysis, physical properties of some recommended materials may have to be generated. It is recommended that a materials test and evaluation program be initiated to define friction, wear, strength, and deflection properties for potential ROVAC vane materials for which no current data exists.

4. Many similar or even identical materials may be considered in a current FEM advanced composite bearing effort. It is recommended that coordination be maintained, with these efforts as they may prove invaluable in the selection of an advanced composite ROVAC vane material.

b. Analysis Verification

Although the reported analysis agrees with ROVAC deflection and loads data, it is recommended that a correlation test program be accomplished which would demonstrate the complete validity of the AVM and NASTRAN models generated in this report. The correlation program would not have to be elaborate and could simply consist of a representative static loading on a baseline ROVAC vane noting overall deflections and several selected strain values.

c. Design Variations

All of the designs considered within this study were restricted to the existing ROVAC design (Figure 4). For this design, geometric variables were constrained to values which may not necessarily be an optimum from a materials/structural relationship point of view. It is therefore recommended that geometric variations from Figure 4 be analyzed for more optimized materials selection. These optimums could then be compared to optimums from an air-cycle machine point of view and trade studies initiated for a fully optimum approach. These design runs could be very easily accomplished through the use of the AVM program developed in this report. In addition to the geometric changes, the AVM program also can rotate the materials axis to any value in four distinct areas. Applications of this capability may lead to still further design improvements.

d. Refined Analysis

All of the design changes studied in Section V assumed that some form of bearing support pin could be structurally integrated into the advanced composite region. Currently, several approaches exist for accomplishing this but all would require modification in areas of maximum stress. In view of this fact, it is recommended that these areas be refined, and the actual attachment method be modeled to determine the best method for bearing-load transition into the vane structure. Here again, the AVM program could be applied so that it possesses the capability to readily refine any area within the vane structure.

e. Margin of Safety (MOS) Study (Recommendation)

Although the stress levels noted in this report appear low, an MOS analysis should be conducted to pinpoint relative vane strength. This analysis would then enable realistic projections to be made relative to the degree of strength reductions permissible for the advanced materials previously recommended.

AFFDL-TR-77-49

APPENDIX A

PROGRAM VANE LISTING IN AVM FORTRAN CODE

AFFDL-TR-77-49

APPENDIX A

PROGRAM VANE LISTING IN AVM FORTRAN CODE

```

W7XKS, STANY, TIC.   D760133, SCHWARTZ, 53011
FTN.
LGO.
REWIND, TAPE7.
COPYSBF, TAPE7, OUTPUT.
REWIND, TAPE7.
COPYBF, TAPE7, PUNCH.
EXIT, S.
      PROGRAM VANE (INPUT, TAPES=INPUT, OUTPUT, TAPES=OUTPUT, TAPE7)
C
C   THIS PROGRAM READS X AND Y DATA FROM CARDS AND CONSTRUCTS
C   A GRID FOR OUTPUT IN NASTRAN FORMAT
C
      COMMON /VANX/X(700), Y(700), XP(5), XTH(5), NP, TH(4)
      COMMON/DUMBAR/XROD1, YROD1, YROD2, NROD, NG1, NG2, ITOT, NR1, NR2
C
C   READ CARD INPUT
      CALL READIN
C
C   CALCULATE X-Y GRID AND PRINT GRID CARDS
      CALL GRID
C
C   CALCULATE AND PRINT VALUES FOR QUAD2 CARDS
      CALL QUAD2
C
C   CALCULATE CBAR VALUES
      IF (NROD.NE.0) CALL CBAR
C
C   CALCULATE SINGLE POINT CONSTRAINTS
      CALL SPC
C
C   CALCULATE MATERIAL AND PROPERTY DATA
      CALL CALCIN
C
      ENDFILE 7
      STOP
      END
      SUBROUTINE READIN
C
C   READIN READS THE FOLLOWING VALUES--
C
C   CARD 1, COL 1-5 - NPX - NO. OF X VALUES
C   CARD 1, COL 6-10 - NPY - NO. OF Y VALUES
C   E, IFMT, AND XJ ARE READ IN SPECIAL FORMAT
C   ALL OTHER VALUES READ WITH 8F10.0 FORMAT
C
      COMMON /VANX/X(700), Y(700), XP(5), XTH(5), NP, TH(4)
      COMMON/DUMBAR/XROD1, YROD1, YROD2, NROD, NG1, NG2, ITOT, NR1, NR2
      COMMON/AGAIN/XIN(75), YIN(75), NPX, NPY, NEL
      COMMON/EXTRA/RADIUS(4), THICK(4), XJ(4), E(8), XMU(8), RHO(8),
1      ALDATA(8), XI(2,4), VEL, AXIS, GRAV
      DIMENSION YR(2)
      LOGICAL PRINT
C
      READ (5, 500) NPX, NPY, PRINT
500 FORMAT (2I5, L1)
C

```

```

      READ (5,510) (XIN(I),I=1,NPX)
      READ (5,510) (YIN(I),I=1,NPY)
510  FORMAT(8F10.0)
      READ (5,510) XP
      READ (5,510) XTH
      READ (5,510) TH
      READ (5,520) NR0D,XR0D1,YR0D1,YR0D2,NEOPTIN
520  FORMAT(I10,3F10.0,I10)
      YR(1)=YR0D1
      YR(2)=YR0D2
      NPYM1=NPY-1
      IF (NEOPTIN.GE.1) GO TO 30
      IF (NR0D.EQ.0) GO TO 30
      DO 15 I=1,NR0D
      DO 10 J=1,NPYM1
      IF (YIN(J).LT.YR(I).AND.YIN(J+1).GT.YR(I)) GO TO 5
      GO TO 10
      5  NPY=NPY+1
      JN=NPY
      7  YIN(JN)=YIN(JN-1)
      JN=JN-1
      IF (JN.GT.J+1) GO TO 7
      YIN(J+1)=YR(I)
      10 CONTINUE
      15 CONTINUE
C
C
C  READS IN ALL OF THE MATERIALS AND PROPERTIES TYPE DATA
30  CONTINUE
      READ (5,500) IFMT
      IF (IFMT.NE.1) GO TO 100
      READ (5,540) XJ
540  FORMAT(4CX,4F10.0)
      READ (5,510) THICK,RADIUS
      READ (5,530) E
530  FORMAT(8(2X,A8))
      READ (5,510) XMU,RHO,VEL,AXIS,GRAV
      READ (5,510) ALDATA
      IF (PRINT) CALL LISTIN
      RETURN
100  PRINT 600
600  FORMAT(* THIS AREA NOT IMPLEMENTED.*)
      STOP
      FND
      SUBROUTINE GRID
C
C  THIS ROUTINE CALCULATES THE X-Y GRID POINTS FROM THE INPUT VALUES
C
      COMMON /VANX/X(700),Y(700),XP(5),XTH(5),NP,TH(4)
      COMMON /AGAIN/XIN(75),YIN(75),NPX,NPY,NEL
      COMMON /DUMBAR/XR0D1,YR0D1,YR0D2,NR0D,NG1,NG2,ITJT,NR1,NR2
      NP=0
      DO 15 J=1,NPY
      DO 15 K=1,NPX
      NP=NP+1
      X(NP)=XIN(K)
      Y(NP)=YIN(J)
15  CONTINUE

```

```

C
      IF (NR0D.EQ.0) GO TO 500
C
C      CALCULATE GRID VALUES FOR FIRST BAR
C
      XINC=ABS(XIN(1)-XROD1)/5.
      NG1=NP
      DO 100 J=1,5
      NG1=NG1+1
      X(NG1)=XFOD1+(J-1)*XINC
      Y(NG1)=YROD1
100 CONTINUE
C
C      DO I HAVE TO CALCULATE NEW POINTS THROUGH STRUCTURE?
      NR1=0
      DO 110 J=1,NPY
      IF (YROD1.EQ.YIN(J)) GO TO 130
110 CONTINUE
C      NO MATCH
C      MAKE NEW GRID POINTS
      DO 120 J=1,NPX
      NG1=NG1+1
      X(NG1)=XIN(J)
      Y(NG1)=YFOD1
120 CONTINUE
      GO TO 150
130 NR1=J
C
C      ROD 2
      NR2=0
150 IF (NR0D.LT.2) GO TO 500
      DO 170 J=1,NPY
      IF (YROD2.EQ.YIN(J)) GO TO 250
170 CONTINUE
C      NO MATCH - NEW GRID POINTS
C
      NG2=NG1
      DO 200 J=1,NPX
      NG2=NG2+1
      X(NG2)=XIN(J)
      Y(NG2)=YROD2
200 CONTINUE
      GO TO 500
250 NR2=J
C      WRITE GRID CARDS
500 ITOT=MAX0(NP,NG1,NG2)
      WRITE (7,700) (J,X(J),Y(J),J=1,ITOT)
700 FORMAT(4HGRID,4X,I8,8X,2F8.2,8H      C.00)
      RETURN
      END
      SUBROUTINE CQUAD2
C
C      CALCULATE AND PRINT CQUAD2 CARDS
      COMMON /VANX/X(700),Y(700),XP(5),XTH(5),NP,TH(4)
      COMMON /AGAIN/XIN(75),YIN(75),NPX,NPY,NEL
      DIMENSION IGP(4)
      NEL=0
      NXL=NPX-1

```

AD-A045 701

AIR FORCE FLIGHT DYNAMICS LAB WRIGHT-PATTERSON AFB OHIO F/G 1/3
STRUCTURAL ANALYSIS OF A VANE FOR AN ADVANCED ENVIRONMENTAL CON--ETC(U)
JUN 77 K P SCHWARTZ
AFFDL-TR-77-49

UNCLASSIFIED

NL

2 OF 2
ADA
045701

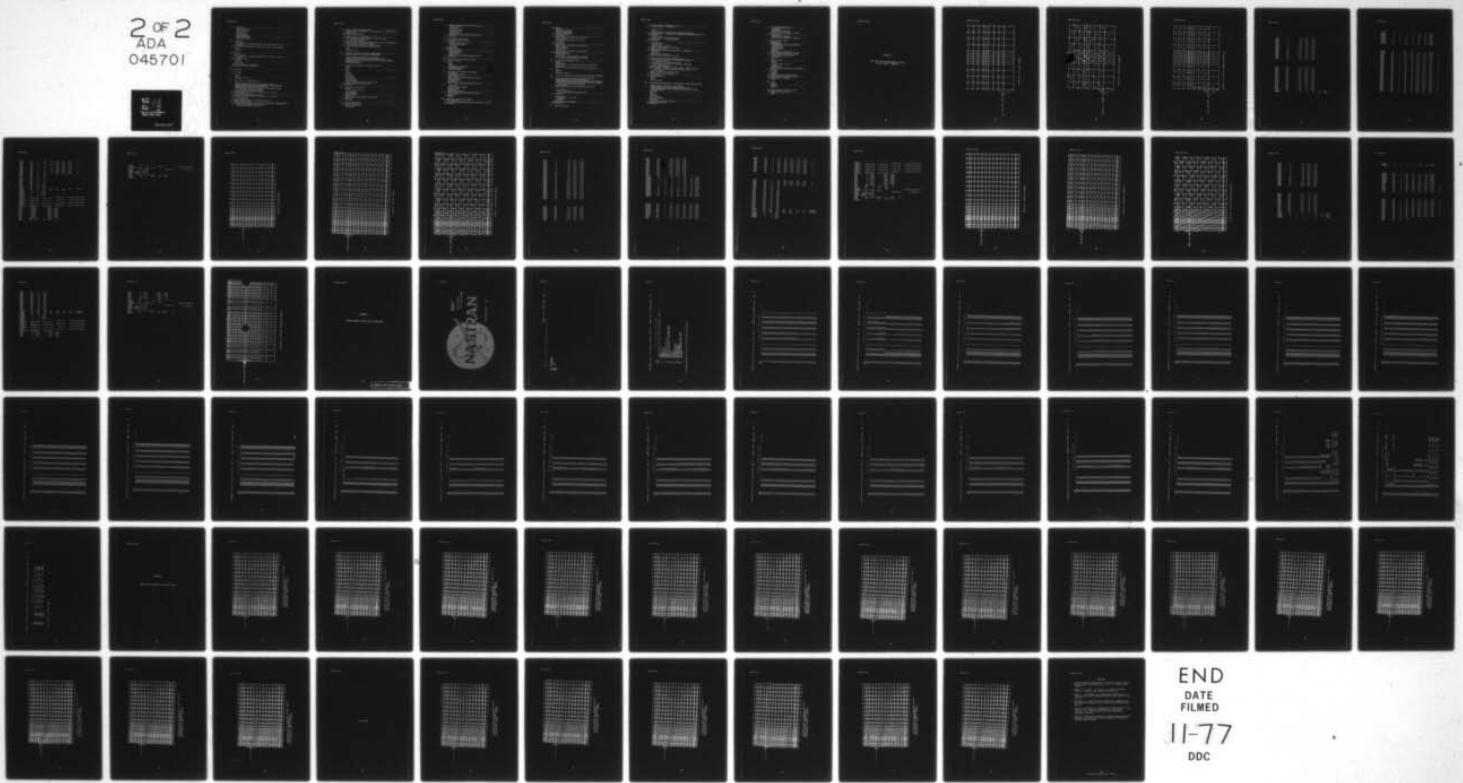

END
DATE
FILMED
11-77
DDC

```

NYL=NPY-1
DO 50 J=1,NYL
IGP(1)=(J-1)*NPX
DO 30 K=1,NXL
NEL=NEL+1
IGP(1)=IGP(1)+1
IGP(2)=IGP(1)+1
IGP(3)=IGP(2)+NPX
IGP(6)=IGP(1)+NPX
C
C   FIND PID
DO 5 M=1,4
IF (X(IGP(2)).GT.XP(M).AND.X(IGP(2)).LE.XP(M+1)) GO TO 7
5 CONTINUE
C ** SET IP=0 SO ERROR CAN BE CHECKED (THIS SHOULD NEVER HAPPEN)
IP=0
GO TO 10
7 IP=M
C
C   FIND TH
DO 15 M=1,4
IF (X(IGP(2)).GT.XTH(M).AND.X(IGP(2)).LE.XTH(M+1)) GO TO 20
15 CONTINUE
C ** DO SAME AS ABOVE
THX=0.
GO TO 25
20 THX=TH(M)
25 WRITE (7,700) NEL,IP,IGP,THX
700 FORMAT(6HQUAD2,2X,6I8,F8.3)
C
C
30 CONTINUE
C
50 CONTINUE
C
RETURN
END
SUBROUTINE LISTIN
C
C   LIST WRITES ALL INPUT PARAMETERS
C
COMMON /VANX/X(700),Y(700),XP(5),XTH(5),NP,TH(4)
COMMON/DUMBAR/XROD1,YROD1,YROD2,NROD,NG1,NG2,IIJT,NR1,NR2
COMMON/AGAIN/XIN(75),YIN(75),NPX,NPY,NEL
COMMON/EXTPA/RADIUS(4),THICK(4),XJ(4),E(8),XMU(8),RHO(8),
1 ALDATA(8),XI(2,4),VEL,AXIS,GRAV
WRITE (6,600) NPX,(XIN(I),I=1,NPX)
600 FORMAT(*1PROGRAM READ *,I3,* X-VALUES AS FOLLOWS--*/
1 (10X,10F10.2))
WRITE (6,610) NPY,(YIN(I),I=1,NPY)
610 FORMAT(///5X,*AND READ *,I3,* Y-VALUES AS FOLLOWS--*/
1 (10X,10F10.2))
WRITE (6,620) XP
620 FORMAT(///5X,*PROPERTY ID DIVISIONS--*,5F10.2)
WRITE (6,630) XTH,TH
630 FORMAT(///5X,*MATERIAL PROPERTY ORIENTATION ANGLE INFORMATION--*/
1 10X,*DATA DIVISIONS--*,5F10.2/,10X,
2 *ORIENTATION ANGLES--*,4F10.2)

```

```

C
WRITE (6,640) XROD1,YROD1,YROD2
640 FORMAT (///5X,*XROD1=*,F8.2,*, YROD1=*,F8.2,*, YROD2=*,F8.2)
WRITE (6,699)
699 FORMAT (///5X,*PROPERTY      1      2      3      4
X 5      6      7      8 * )
WRITE (6,700) XJ,THICK,RADIUS
700 FORMAT (///5X,*J=*,42X,4F10.3//5X,*THICK=*,4F10.3//
1 5X,*RADIUS=*,37X,4F10.3)
WRITE (6,710) F,XMU,RHO
710 FORMAT (//5X,*E=*,4X,8A10//5X,*XMU=*,8F10.3//5X,*RHO=*,8F10.3)
WRITE (6,720) VEL,AXIS,GRAV,ALDATA
720 FORMAT (//5X,*VEL=*,F10.3,*, AXIS=*,F10.3,
1 *, GRAV=*,F10.3//5X,*ALDATA=*,8F10.3)
RETURN
END
SUBROUTINE CBAR
C
C CALCULATES AND PRINTS VALUES FOR CBAR CARDS
C SINCE APOLOGIES TO STRUCTURED PROGRAMMING
C
COMMON/AGAIN/XIN(75),YIN(75),NPX,NPY,NEL
COMMON /VANX/X(700),Y(700),XP(5),XTH(5),NP,TH(4)
COMMON/DUMBAR/XROD1,YROD1,YROD2,NROD,NG1,NG2,ITOT,NR1,NR2
DIMENSION IGP(2)
NFX(NN)=(NN-1)*NPX+1
C
C CALCULATE ALL HORIZONTAL CBAR VALUES FOR ROD 1
IPID=5
X1=0.
X2=1.
X3=0.
IF=1
NELB=NEL
IGP(1)=NP
DO 50 J=1,4
NELB=NELB+1
IGP(1)=IGP(1)+1
IGP(2)=IGP(1)+1
WRITE (7,700) NELB,IPID,IGP,X1,X2,X3,IF
700 FORMAT (4HCBAR,4X,4I8,3F8.2,I8)
50 CONTINUE
C
C WHERE DO I GO FROM HERE?
IPID=7
IF (NR1.NE.0) GO TO 100
DO 70 J=1,NPX
IGP(1)=IGP(1)+1
IGP(2)=IGP(1)+1
NELB=NELB+1
WRITE (7,700) NELB,IPID,IGP,X1,X2,X3,IF
70 CONTINUE
GO TO 120
C
C FIND OLD GRID POINTS
100 IGP(1)=IGP(1)+1
IGP(2)=(NR1-1)*NPX+1
NELB=NELB+1

```

```

WRITE (7,700) NELB, IPI0, IGP, X1, X2, X3, IF
IGP(1)=IGP(2)-1
NPXM1=NPX-1
DO 110 J=1, NPXM1
IGP(1)=IGP(1)+1
IGP(2)=IGP(1)+1
NELB=NELB+1
WRITE (7,700) NELB, IPI0, IGP, X1, X2, X3, IF
110 CONTINUE
C
C DO I HAVE A SECOND ROD?
120 IF (NR00.LT.2) GO TO 200
IPI0=8
IF (NR2.EQ.0) GO TO 130
IGP(1)=(NR2-1)*NPX
GO TO 140
130 IGP(1)=NG1
140 NPXM1=NPX-1
DO 150 J=1, NPXM1
IGP(1)=IGP(1)+1
IGP(2)=IGP(1)+1
NELB=NELB+1
WRITE (7,700) NELB, IPI0, IGP, X1, X2, X3, IF
150 CONTINUE
C
C NOW FOR THE VERTICAL BARS ON ROD 1
C FIND TIE POINT
200 X1=1.
X2=0.
IPI0=6
IF (NR1.EQ.0) GO TO 250
NUP=MIND(3, NPY-NR1)
NDN=MIND(3, NR1)
C
C BAR CARDS FOR EXISTING GRID POINTS
NELB=NELB+1
IGP(1)=(NR1-2)*NPX+1
IGP(2)=NP+5
WRITE (7,700) NELB, IPI0, IGP, X1, X2, X3, IF
IGP(1)=IGP(2)
IGP(2)=NR1*NPX+1
NELB=NELB+1
WRITE (7,700) NELB, IPI0, IGP, X1, X2, X3, IF
C
NTO=NUP+NDN
IGP(1)=(NR1-NDN-1)*NPX+1
DO 210 J=1, NTO
NELB=NELB+1
IGP(2)=IGP(1)+NPX
WRITE (7,700) NELB, IPI0, IGP, X1, X2, X3, IF
IGP(1)=IGP(2)
210 CONTINUE
RETURN
C
C BAR CARDS FOR NEW GRID POINTS
250 DO 260 J=2, NPY
IF (YIN(J).GT.YROD1.AND.YIN(J-1).LT.YROD1) GO TO 265
260 CONTINUE

```

```

265 NTOP=J
      NROT=J-1
      NUP=MIN0(2,NPY-NTOP)
      NDN=MIN0(2,(NROT-1))
      IGP(1)=NFX(NBOT-NDN)
270 IGP(2)=IGP(1)+NPX
      NELB=NELP+1
      WRITE (7,700) NFLB,IPID,IGP,X1,X2,X3,IF
      IGP(1)=IGP(2)
      IF (IGP(1).EQ.NFX(NBOT)) GO TO 280
      GO TO 270
280 IGP(2)=NP+6
      NELB=NELP+1
      WRITE (7,700) NFLB,IPID,IGP,X1,X2,X3,IF
      IGP(1)=IGP(2)
      IGP(2)=NFX(NTOP)
      NELB=NELP+1
      WRITE (7,700) NELB,IPID,IGP,X1,X2,X3,IF
290 IGP(1)=IGP(2)
      IGP(2)=IGP(1)+NPX
      NELB=NELP+1
      WRITE (7,700) NELB,IPID,IGP,X1,X2,X3,IF
      IF (IGP(2).LT.NFX(NUP+NTOP)) GO TO 290
C
C DO TWO STRANGE DIAGONAL BARS
      IPID=5
      NELB=NELB+1
      WRITE (7,700) NELB,IPID,NFX(NBOT),NP+5,X1,X2,X3,IF
      NELB=NELB+1
      WRITE (7,700) NELB,IPID,NP+5,NFX(NTOP),X1,X2,X3,IF
C
      RETURN
      END
      SUBROUTINE CALCIN
C
C THIS ROUTINE CALCULATES MATERIALS AND PROPERTIES TYPE DATA
C
      COMMON /VANX/X(700),Y(700),XP(5),XTH(5),NP,TH(4)
      COMMON/AGAIN/XIN(75),YIN(75),NPX,NPY,NEL
      COMMON/DUMBAR/XROD1,YROD1,YROD2,NROD,NG1,NG2,ITOT,NR1,NR2
      COMMON/EXTRA/RADIUS(4),THICK(4),XJ(4),E(8),X4U(8),RHO(8),
1 ALDATA(8),XI(2,4),VEL,AXIS,GRAV
      DIMENSION A(4)
      DATA PI/3.14159265/,ZERO,ONE,ONENEG/0.,1.,-1./
C
      DO 10 J=1,4
      A(J)=PI*RADIUS(J)**2
      XI(1,J)=XI(2,J)=PI*RADIUS(J)**4/4.
10 CONTINUE
C
      VELC=VEL/60.
      IF (GRAV.EQ.0) GO TO 699
      GACEL=GRAV
      GO TO 701
699 GACEL=ALDATA(1)*ALDATA(2)
701 CONTINUE
C
C WRITE EXTRA CARDS

```

```

WRITE (7,700) (J,J,THICK(J),J=1,4)
700 FORMAT(*PQUAD2 *,2I8,F8.4)
C
DO 115 J=1,4
JS=J+4
WRITE (7,705) JS,JS,A(J),XI(1,J),J,J,XI(2,J),XJ(J)
705 FORMAT(8HPBAR*,2I16,2E16.7,*QABCDEF*,I1/7H*ABCDEF,I1,2E16.7)
115 CONTINUE
DO 120 J=1,3
WRITE (7,710) J,E(J),XMU(J),RHO(J)
710 FORMAT(*MAT1 *,I8,A8,8X,2F8.4)
120 CONTINUE
C
IRS=NPX*NPY+1
ITOTP1=ITOT+1
WRITE (7,715) IRS,ITOTP1
715 FORMAT(*SPC1*,9X,*500 123456*,2I8)
WRITE (7,717) ITOT
717 FORMAT(*SPC1*,9X,*501*,7X,*6*,7X,*1 THRU*,I8)
IRS1=IRS+1
IBS2=IBS+2
WRITE (7,720) IBS1,IBS2
720 FORMAT(*SPC1*,9X,*502*,7X,*2*,2I8)
C
WRITE (7,725) ITOTP1,VELC,ONE,ZERO,ZERO
725 FORMAT(7HRFORCE*,15X,*20*,I16,16X,E16.7,*2RFORCE1*/
1 8H+RFORCE1, 3F8.4)
WRITE (7,730) GAGEL,ZERO,ONENEG,ZERO
730 FORMAT(5HGRAV*,17X,*21*,16X,E16.7,F16.4,*2GRAV1*/
1 6H+GRAV1,2X,2F8.4)
WRITE (7,735) ONE,ONE,ONE
735 FORMAT(*PARAM WTMASS .002588*/*PARAM GRDPNT*,9X,*0*/
1 *LOAD*,10X,*30*,2F8.4,6X,*20*,F8.4,6X,*21*)
YAX=YIN(1)+AXIS
WRITE (7,740) ITOTP1,ZERO,YAX,ZERO
740 FORMAT(*GRID*,4X,I8,8X,3F8.3)
WRITE(7,741)
741 FORMAT(*ENDDATA*)
RETURN
END
SUBROUTINE SPC
C
C SPC CALCULATES CONSTRAINTS FOR EACH NODE AT RIGHT EDGE OF VANE
C
COMMON/AGAIN/XIN(75),YIN(75),NPX,NPY,NEL
COMMON /VANX/X(700),Y(700),X(5),XTH(5),N,TH(4)
COMMON/DUMBAR/XROD1,YROD1,YROD2,NROD,NG1,NG2,ITOT,NR1,NR2
DIMENSION ISP(80)
ISP(1)=99
NL=0
ICON=15
NSPC=NPY
DO 10 J=1,NPY
ISP(J+1)=ISP(J)+1
NL=NL+NPY
WRITE (7,700) ISP(J+1),ICON,NL
700 FORMAT(4HSPC1,4X,3I8)
10 CONTINUE

```

```

IF (NR0D.EQ.0) GO TO 20
IF (NR1.NE.0) GO TO 15
NSPC=NSPC+1
ISP(NSPC+1)=ISP(NSPC)+1
WRITE (7,700) ISP (NSPC+1),ICON,NG1
15 IF (NR2.NE.0) GO TO 20
NSPC=NSPC+1
ISP(NSPC+1)=ISP(NSPC)+1
WRITE (7,700) ISP(NSPC+1),ICON,NG2
C
C WRITE SPC TOTAL CARD
20 NSPC=NSPC+4
NCARD=NSPC/8
IF (MOD(NSPC,8).NE.0) NCARD=NCARD+1
ISP(NSPC-2)=500
ISP(NSPC-1)=501
ISP(NSPC)=502
NCONT=10
IF (NCARD.EQ.1) GO TO 201
WRITE (7,710) (ISP(I),I=1,8),NCONT
710 FORMAT (6HSPCADD,2X,8I8,3HABC,I2)
IF (NCARD.LE.2) GO TO 100
NCR=NCARD-1
I1=1
DO 50 J=1,NCR
I1=I1+8
IS=I1+7
IF (IS.GE.NSPC) GO TO 70
IO=NCONT
NCONT=NCONT+1
WRITE (7,720) IO,(ISP(I),I=I1,IS),NCONT
50 CONTINUE
I1=I1+8
70 IS=NSPC
IO=NCONT
720 FORMAT (3H+BC,I2,3X,8I8,3HABC,I2)
75 WRITE (7,730) IO,(ISP(I),I=I1,IS)
730 FORMAT (3H+BC,I2,3X,8I8)
RETURN
C
100 I1=9
IS=NSPC
IO=10
NCONT=11
GO TO 75
C
200 WRITE (7,740) (ISP(I),I=1,NSPC)
740 FORMAT (6HSPCADD,2X,8I8)
RETURN
END

```

AFFDL-TR-77-49

APPENDIX B

TEST CASE PLOTS AND ABBREVIATED LISTINGS
FOR TEST CASES 1 THROUGH 4

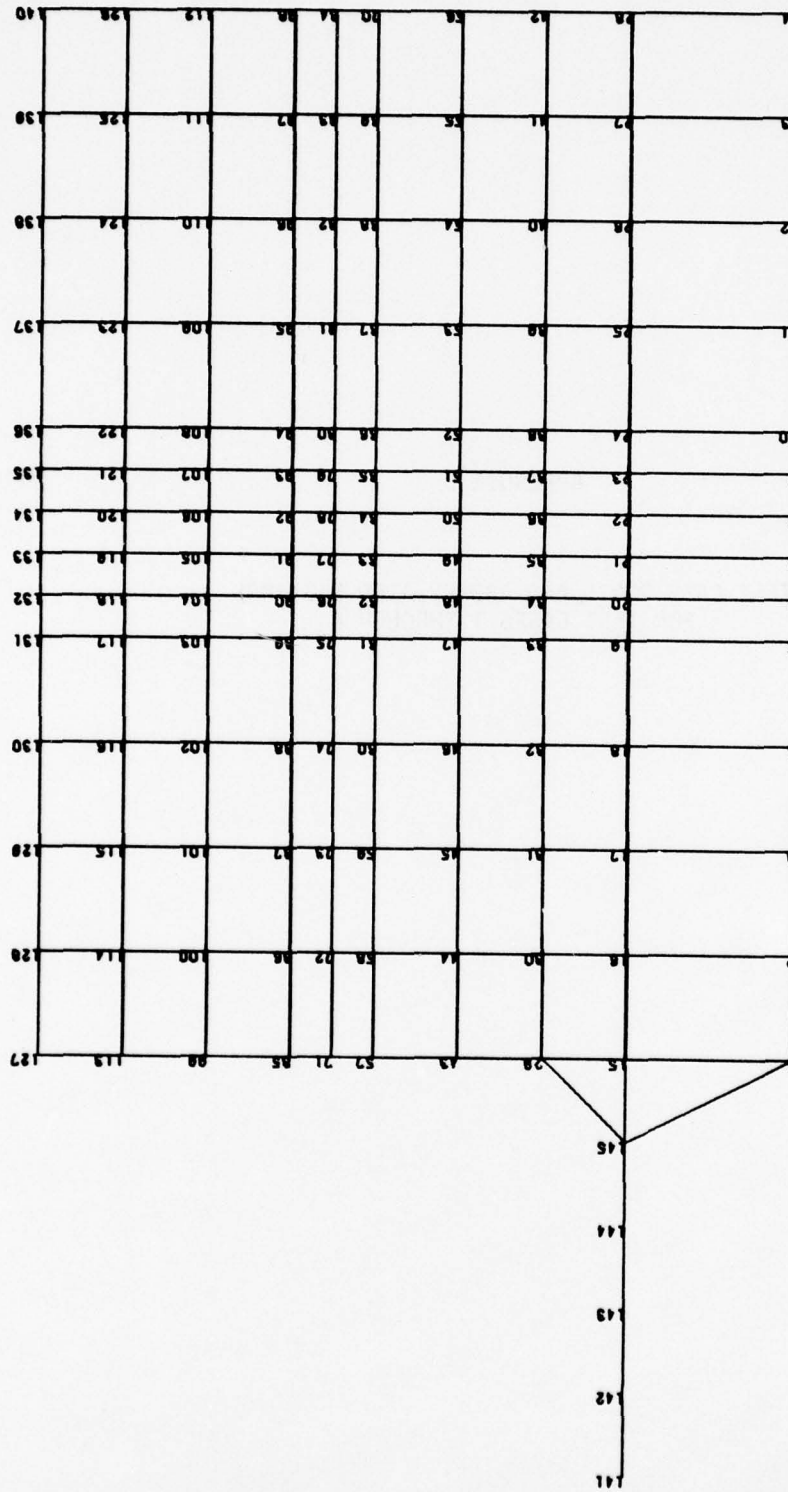

Figure B-1. Test Case 1 (Nodes)

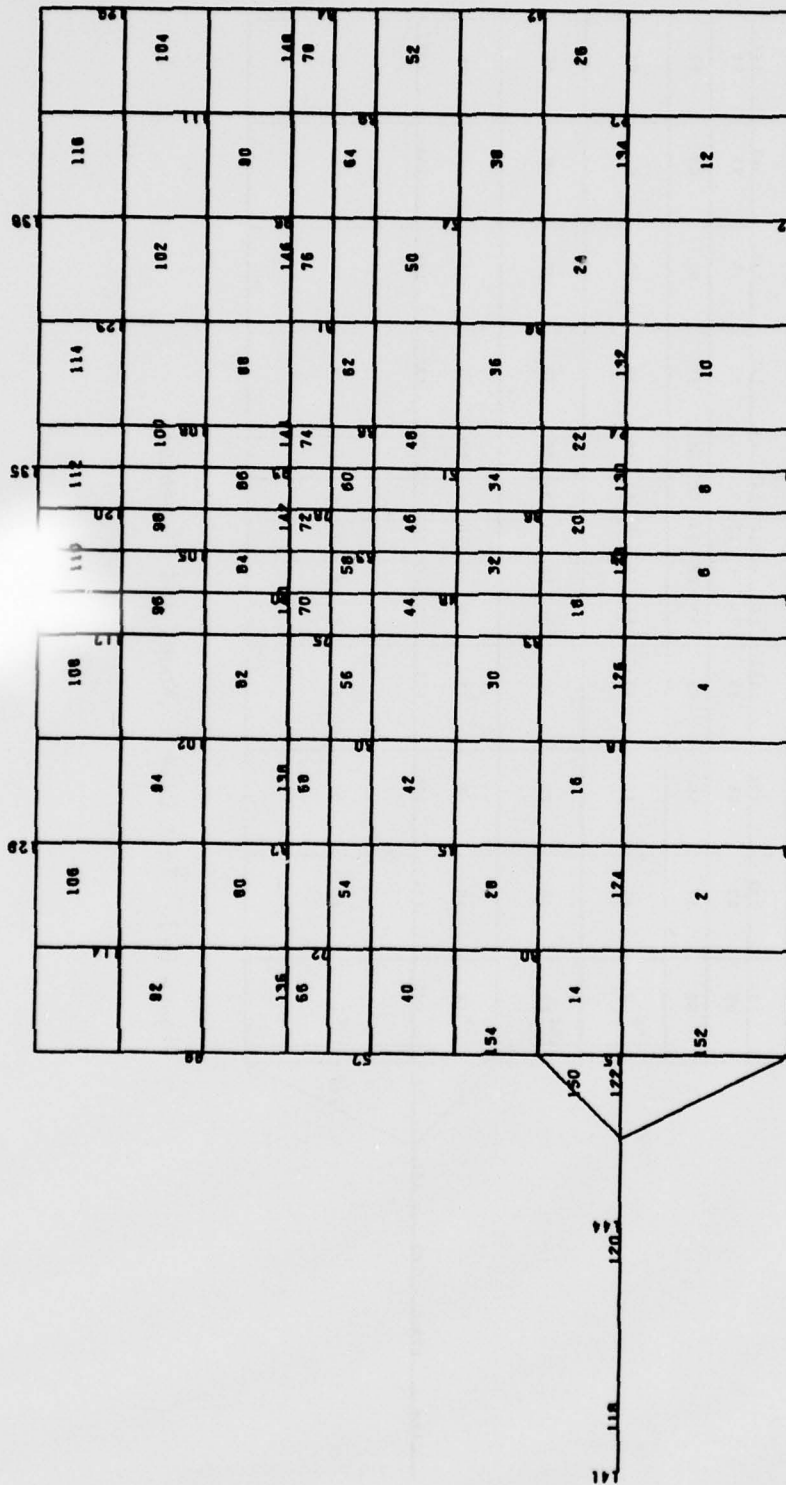

Figure B-2. Test Case 1 (Elements)

105	106	107	108	109	110	111	112	113	114	115	116	117
92	93	94	95	96	97	98	99	100	101	102	109	104
79	80	81	82	83	84	85	86	87	88	89	90	91
136	137	138	139	140	141	142	143	144	145	146	147	148
66	67	68	69	70	71	72	73	74	75	76	77	78
53	54	55	56	57	58	59	60	61	62	63	64	65
155 40	41	42	43	44	45	46	47	48	48	50	51	52
154 27	28	29	30	31	32	33	34	35	36	37	38	38
153 14	15	16	17	18	19	20	21	22	23	24	25	26
123	124	125	126	127	128	129	130	131	132	133	134	135
152 1	2	3	4	5	6	7	8	9	10	11	12	13

Figure B-3. Test Case 1 (Nodes and Elements)

GRID	1	0.00	0.00	0.00
GRID	2	.25	0.00	0.00
GRID	3	.50	0.00	0.00
GRID	4	.75	0.00	0.00
GRID	5	1.00	0.00	0.00
GRID	6	1.10	0.00	0.00
GRID	7	1.20	0.00	0.00
GRID	8	1.30	0.00	0.00
GRID	9	1.40	0.00	0.00
GRID	10	1.50	0.00	0.00
GRID	11	1.75	0.00	0.00
GRID	12	2.00	0.00	0.00
GRID	13	2.25	0.00	0.00
GRID	14	2.50	0.00	0.00
GRID	15	0.00	.40	0.00
GRID	16	.25	.40	0.00

GRID	129	.50	1.80	0.00
GRID	130	.75	1.80	0.00
GRID	131	1.00	1.80	0.00
GRID	132	1.10	1.80	0.00
GRID	133	1.20	1.80	0.00
GRID	134	1.30	1.80	0.00
GRID	135	1.40	1.80	0.00
GRID	136	1.50	1.80	0.00
GRID	137	1.75	1.80	0.00
GRID	138	2.00	1.80	0.00
GRID	139	2.25	1.80	0.00
GRID	140	2.50	1.80	0.00
GRID	141	-1.00	.40	0.00
GRID	142	-.60	.40	0.00
GRID	143	-.60	.40	0.00
GRID	144	-.40	.40	0.00
GRID	145	-.20	.40	0.00

CQUAD2	1	1	2	16	15	0.000
CQUAD2	2	1	2	3	17	0.000

CQUAD2	3	2	3	4	18	17	0.000
CQUAD2	4	2	4	5	19	18	0.000
CQUAD2	5	3	5	6	20	19	0.000
CQUAD2	6	3	6	7	21	20	0.000
CQUAD2	7	4	7	8	22	21	0.000
CQUAD2	8	4	8	9	23	22	0.000
CQUAD2	9	4	9	10	24	23	0.000
CQUAD2	10	4	10	11	25	24	0.000
CQUAD2	11	4	11	12	26	25	0.000

CQUAD2	116	4	124	125	139	138	0.000	
CQUAD2	117	4	125	126	140	139	0.000	
CBAR	118	5	141	142	0.00	1.00	0.00	1
CBAR	119	5	142	143	0.00	1.00	0.00	1
CBAR	120	5	143	144	0.00	1.00	0.00	1
CBAR	121	5	144	145	0.00	1.00	0.00	1
CBAR	122	7	145	15	0.00	1.00	0.00	1
CBAR	123	7	15	16	0.00	1.00	0.00	1
CBAR	124	7	16	17	0.00	1.00	0.00	1
CBAR	125	7	17	18	0.00	1.00	0.00	1
CBAR	126	7	18	19	0.00	1.00	0.00	1
CBAR	127	7	19	20	0.00	1.00	0.00	1
CBAR	128	7	20	21	0.00	1.00	0.00	1
CBAR	129	7	21	22	0.00	1.00	0.00	1
CBAR	130	7	22	23	0.00	1.00	0.00	1
CBAR	131	7	23	24	0.00	1.00	0.00	1
CBAR	132	7	24	25	0.00	1.00	0.00	1
CBAR	133	7	25	26	0.00	1.00	0.00	1
CBAR	134	7	26	27	0.00	1.00	0.00	1
CBAR	135	7	27	28	0.00	1.00	0.00	1
CBAR	136	8	85	86	0.00	1.00	0.00	1
CBAR	137	8	86	87	0.00	1.00	0.00	1
CBAR	138	8	87	88	0.00	1.00	0.00	1
CBAR	139	8	88	89	0.00	1.00	0.00	1
CBAR	140	8	89	90	0.00	1.00	0.00	1
CBAR	141	8	90	91	0.00	1.00	0.00	1
CBAR	142	8	91	92	0.00	1.00	0.00	1
CBAR	143	8	92	93	0.00	1.00	0.00	1
CBAR	144	8	93	94	0.00	1.00	0.00	1
CBAR	145	8	94	95	0.00	1.00	0.00	1

CBAR	146	8	95	96	0.00	1.00	0.00	1
CBAR	147	8	96	97	0.00	1.00	0.00	1
CBAR	148	8	97	98	0.00	1.00	0.00	1
CBAR	149	8	1	149	1.00	0.00	0.00	1
CBAR	150	8	145	29	1.00	0.00	0.00	1
CBAR	151	8	-13	1	1.00	0.00	0.00	1
CBAR	152	8	1	15	1.00	0.00	0.00	1
CBAR	153	8	15	29	1.00	0.00	0.00	1
CBAR	154	8	29	43	1.00	0.00	0.00	1
CBAR	155	8	43	57	1.00	0.00	0.00	1
SPC1	100	15	14					
SFC1	101	15	23					
SFC1	102	15	42					
SFC1	103	15	56					
SPC1	104	15	70					
SPC1	105	15	84					
SPC1	106	15	98					
SPC1	107	15	112					
SFC1	108	15	126					
SPC1	109	15	140					
SPCAD0	99	100	101	102	103	104	105	105ABC10
+BC1C	107	108	109	500	501	502		
PQUAD2	1	1	.7500					
PQUAD2	2	2	.7500					
PQUAD2	3	3	.7500					
PQUAD2	4	4	.7500					
PBAR*	5			5	.1130973E+01		.1017376E+01	03QA3CDEF1
*ABCDEF1	.1017876E+01		.7500000E+00	6	.2544690E+01		.5152997E+01	03QA3CDEF2
PBAR*	6			6	.7068533E-01		.3976078E-01	03QA3CDEF3
*ABCDEF2	.5152997E+01		.3500000E+00	7	.7068533E-01		.3976078E-01	03QA3CDEF4
PBAR*	7			7				
*ABCDEF3	.3976078E-01		.3500000E+00	8				
PBAR*	8			8				
*ABCDEF4	.3976078E-01		.3500000E+00					
MAT1	13.0E7		.2500	.2500				
MAT1	23.0E7		.2500	.2500				
MAT1	33.0E7		.2500	.2500				
MAT1	43.0E7		.2500	.2500				
MAT1	52.8E7		.3000	.2500				
MAT1	62.8E7		.3000	.2500				
MAT1	72.8E7		.3000	.2500				
MAT1	82.8E7		.3000	.2500				
SPC1	500	123456	141	146				
SPC1	501	6	1	THRU	145			

AFFDL-TR-77-49

```
SPC1      502      2      142      143
RFORCE*   20      146      .3333333E+02QRFORCE1
+KFORCE1  1.0000  0.0000  0.0000
GRAV*     21      .3800000E+06      0.0000QGRAV1
+GRAV1    -1.0000  0.0000
PARAM     WTMASS .002508
PARAM     GRDPNT  0
LOAD      30      1.0000  1.0000      20      1.0000      21
GRID      146      0.0000  4.0000  0.0000
ENDDATA
```

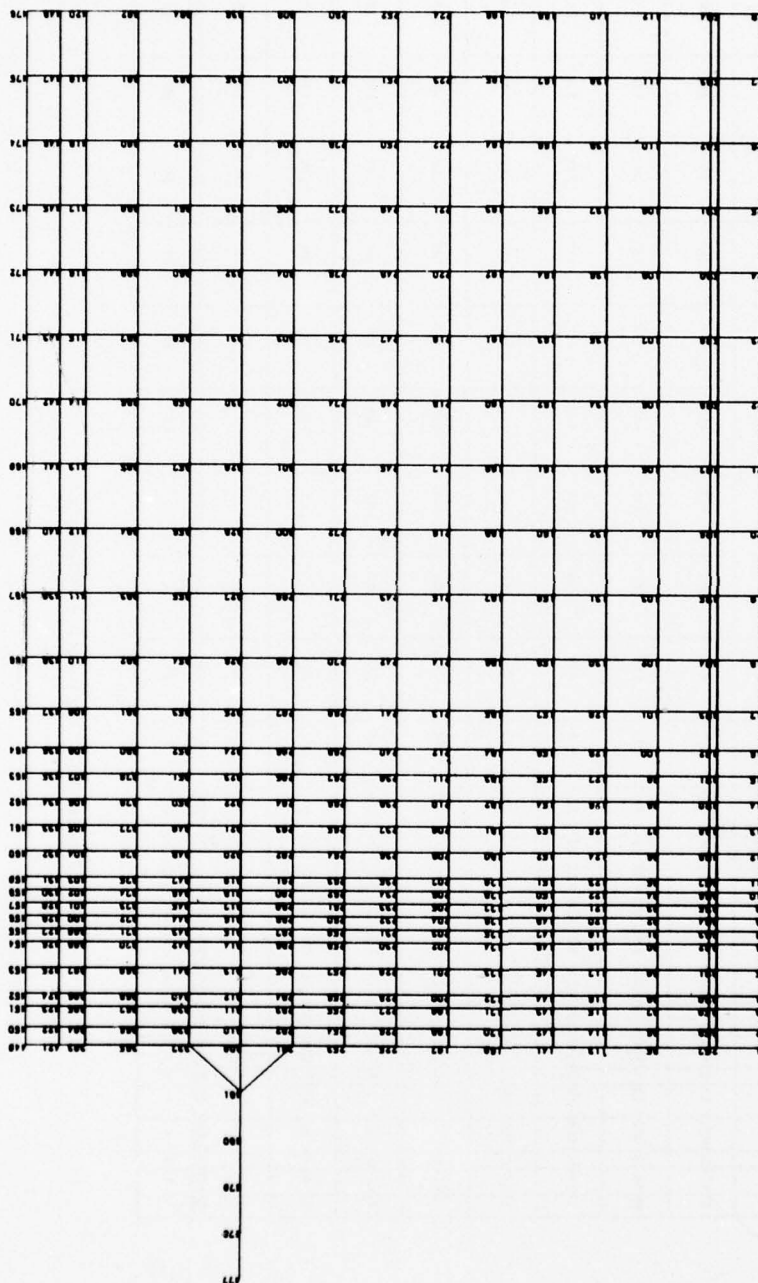

Figure B-4. Test Case 2 (Nodes)

416	417	418	419	420	421	422	423	424	425	426	427	428	429	430	431	432
433	434	435	436	437	438	439	440	441	442	443	444	445	446	447	448	449
450	451	452	453	454	455	456	457	458	459	460	461	462	463	464	465	466
467	468	469	470	471	472	473	474	475	476	477	478	479	480	481	482	483
484	485	486	487	488	489	490	491	492	493	494	495	496	497	498	499	500
501	502	503	504	505	506	507	508	509	510	511	512	513	514	515	516	517
518	519	520	521	522	523	524	525	526	527	528	529	530	531	532	533	534
535	536	537	538	539	540	541	542	543	544	545	546	547	548	549	550	551
552	553	554	555	556	557	558	559	560	561	562	563	564	565	566	567	568
569	570	571	572	573	574	575	576	577	578	579	580	581	582	583	584	585
586	587	588	589	590	591	592	593	594	595	596	597	598	599	600	601	602
603	604	605	606	607	608	609	610	611	612	613	614	615	616	617	618	619
620	621	622	623	624	625	626	627	628	629	630	631	632	633	634	635	636
637	638	639	640	641	642	643	644	645	646	647	648	649	650	651	652	653
654	655	656	657	658	659	660	661	662	663	664	665	666	667	668	669	670
671	672	673	674	675	676	677	678	679	680	681	682	683	684	685	686	687
688	689	690	691	692	693	694	695	696	697	698	699	700	701	702	703	704
705	706	707	708	709	710	711	712	713	714	715	716	717	718	719	720	721
722	723	724	725	726	727	728	729	730	731	732	733	734	735	736	737	738
739	740	741	742	743	744	745	746	747	748	749	750	751	752	753	754	755
756	757	758	759	760	761	762	763	764	765	766	767	768	769	770	771	772
773	774	775	776	777	778	779	780	781	782	783	784	785	786	787	788	789
790	791	792	793	794	795	796	797	798	799	800	801	802	803	804	805	806
807	808	809	810	811	812	813	814	815	816	817	818	819	820	821	822	823
824	825	826	827	828	829	830	831	832	833	834	835	836	837	838	839	840
841	842	843	844	845	846	847	848	849	850	851	852	853	854	855	856	857
858	859	860	861	862	863	864	865	866	867	868	869	870	871	872	873	874
875	876	877	878	879	880	881	882	883	884	885	886	887	888	889	890	891
892	893	894	895	896	897	898	899	900	901	902	903	904	905	906	907	908
909	910	911	912	913	914	915	916	917	918	919	920	921	922	923	924	925
926	927	928	929	930	931	932	933	934	935	936	937	938	939	940	941	942
943	944	945	946	947	948	949	950	951	952	953	954	955	956	957	958	959
960	961	962	963	964	965	966	967	968	969	970	971	972	973	974	975	976
977	978	979	980	981	982	983	984	985	986	987	988	989	990	991	992	993
994	995	996	997	998	999	1000	1001	1002	1003	1004	1005	1006	1007	1008	1009	1010

Figure B-5. Test Case 2 (Elements)

AFFDL-TR-77-49

GRID	1	0.00	0.00	0.00
GRID	2	.07	0.00	0.00
GRID	3	.15	0.00	0.00
GRID	4	.20	0.00	0.00
GRID	5	.30	0.00	0.00
GRID	6	.40	0.00	0.00
GRID	7	.45	0.00	0.00
GRID	8	.50	0.00	0.00
GRID	9	.55	0.00	0.00
GRID	10	.60	0.00	0.00
GRID	11	.65	0.00	0.00
GRID	12	.75	0.00	0.00
GRID	13	.85	0.00	0.00
GRID	14	.95	0.00	0.00
GRID	15	1.05	0.00	0.00
GRID	16	1.15	0.00	0.00
GRID	17	1.30	0.00	0.00
GRID	18	1.50	0.00	0.00
GRID	19	1.75	0.00	0.00
GRID	20	2.00	0.00	0.00
GRID	21	2.25	0.00	0.00
GRID	22	2.50	0.00	0.00
GRID	23	2.75	0.00	0.00
GRID	24	3.00	0.00	0.00
GRID	25	3.25	0.00	0.00
GRID	26	3.50	0.00	0.00
GRID	27	3.75	0.00	0.00
GRID	28	4.00	0.00	0.00
GRID	29	0.00	.17	0.00

GRID	459	.05	2.83	0.00
GRID	460	.75	2.83	0.00
GRID	461	.85	2.83	0.00
GRID	462	.95	2.83	0.00
GRID	463	1.05	2.83	0.00
GRID	464	1.15	2.83	0.00
GRID	465	1.30	2.83	0.00
GRID	466	1.50	2.83	0.00
GRID	467	1.75	2.83	0.00
GRID	468	2.00	2.83	0.00

GRID	469		2.25	2.00	0.00		
GRID	470		2.50	2.00	0.00		
GRID	471		2.75	2.00	0.00		
GRID	472		3.00	2.00	0.00		
GRID	473		3.25	2.00	0.00		
GRID	474		3.50	2.00	0.00		
GRID	475		3.75	2.00	0.00		
GRID	476		4.00	2.00	0.00		
GRID	477		-.90	2.00	0.00		
GRID	478		-.72	2.00	0.00		
GRID	479		-.54	2.00	0.00		
GRID	480		-.36	2.00	0.00		
GRID	481		-.18	2.00	0.00		
CQUAD2	1	1	1	2	30	29	0.000
CQUAD2	2	1	2	3	31	30	0.000
CQUAD2	3	2	3	4	32	31	0.000
CQUAD2	4	2	4	5	33	32	0.000
CQUAD2	5	2	5	6	34	33	0.000
CQUAD2	6	2	6	7	35	34	0.000
CQUAD2	7	2	7	8	36	35	0.000
CQUAD2	8	2	8	9	37	36	0.000
CQUAD2	9	2	9	10	38	37	0.000
CQUAD2	10	2	10	11	39	38	0.000
CQUAD2	11	3	11	12	40	39	0.000
CQUAD2	12	3	12	13	41	40	0.000
CQUAD2	13	3	13	14	42	41	0.000
CQUAD2	14	3	14	15	43	42	0.000
CQUAD2	15	3	15	16	44	43	0.000

CQUAD2	424	3	439	440	468	467	0.000	
CQUAD2	425	+	440	441	469	468	0.000	
CQUAD2	426	+	441	442	470	469	0.000	
CQUAD2	427	+	442	443	471	470	0.000	
CQUAD2	428	+	443	444	472	471	0.000	
CQUAD2	429	+	444	445	473	472	0.000	
CQUAD2	430	+	445	446	474	473	0.000	
CQUAD2	431	+	446	447	475	474	0.000	
CQUAD2	432	+	447	448	476	475	0.000	
CBAR	433	5	477	478	0.00	1.00	0.00	1
CBAR	434	5	478	479	0.00	1.00	0.00	1

CBAR	435	5	479	480	0.00	1.00	0.00	1
CBAR	436	5	480	481	0.00	1.00	0.00	1
CBAR	437	7	481	309	0.00	1.00	0.00	1
CBAR	438	7	309	310	0.00	1.00	0.00	1
CBAR	439	7	310	311	0.00	1.00	0.00	1
CBAR	440	7	311	312	0.00	1.00	0.00	1
CBAR	441	7	312	313	0.00	1.00	0.00	1
CBAR	442	7	313	314	0.00	1.00	0.00	1
CBAR	443	7	314	315	0.00	1.00	0.00	1
CBAR	444	7	315	316	0.00	1.00	0.00	1
CBAR	445	7	316	317	0.00	1.00	0.00	1
CBAR	+96	6	281	309	1.00	0.00	0.00	1
CBAR	+97	6	309	337	1.00	0.00	0.00	1
CBAR	+98	6	337	365	1.00	0.00	0.00	1
CBAR	+99	6	365	393	1.00	0.00	0.00	1
SPC1	100	15	28					
SPC1	101	15	50					
SPC1	102	15	84					
SPC1	103	15	112					
SPC1	104	15	140					
SPC1	105	15	168					
SPC1	106	15	196					
SPC1	107	15	224					
SPC1	108	15	252					
SPC1	109	15	280					
SPC1	110	15	308					
SPC1	111	15	336					
SPC1	112	15	364					
SPC1	113	15	392					
SPC1	114	15	420					
SPC1	115	15	448					
SPC1	116	15	476					
SPCA00	99	100	101	102	103	104	105	106A8C10
+8C10	107	108	109	110	111	112	113	114A8C11
+8C11	117	116	500	501	502			
PQUAD2	1	1	.3740					
PQUAD2	2	2	.3740					
PQUAD2	3	3	.3740					
PQUAD2	4	4	.3740					

PBAR*				5	.1256637E+00	.1256637E-02QA3CDEF1
*ABCDEF1	.1256637E-02		.+000000E+00			
PBAR*				6	.3141933E-01	.7553552E-0+QA3CDEF2
*ABCDEF2	.7853982E-0+		.2000000E+00			
PBAR*				7	.1410261E-01	.1532605E-0+QA3CDEF3
*ABCDEF3	.1582665E-0+		.1250000E+00			
PBAR*				8	.7068213E-02	.3998198E-0+QA3CDEF4
*ABCDEF4	.3998198E-0+		.9500000E-01			
MAT1	1	3.0E7		.3200	.2800	
MAT1	2	1.0E7		.3000	.1500	
MAT1	3	3.5E6		.2800	.0660	
MAT1	4	3.5E6		.2800	.0660	
MAT1	5	3.0E7		.3200	.2800	
MAT1	6	3.0E7		.3200	.2800	
MAT1	7	3.0E7		.3200	.2800	
MAT1	8	3.0E7		.3200	.2800	
SPC1	500	123456	477	482		
SPC1	501	6	1	THRU	481	
SPC1	502	2	478	479		
RFORCE*				482		.3333333E+02QRFORCE1
+RFORCE1	0.0000	0.0000	1.0000			
GRAV*					.13+0000E+06	0.0000GRAV1
+GRAV1	1.0000	0.0000				
PARAM	WTMASS	.002588				
PARAM	GRDPNT	0				
LOAD	30	1.0000	1.0000	20	1.0000	21
GRID	+82		0.000	4.000	0.000	
ENDDATA						

148	149	150	151	152	153	154	155	156	157	158	159	160	161	162	163	164	165	166	167	168	169	170	171	172	173	174	175	176	177	178	179	180	181	182	183	184	185	186	187	188	189	190	191	192	193	194	195	196	197	198	199	200	201	202	203	204	205	206	207	208	209	210	211	212	213	214	215	216	217	218	219	220	221	222	223	224	225	226	227	228	229	230	231	232	233	234	235	236	237	238	239	240	241	242	243	244	245	246	247	248	249	250	251	252	253	254	255	256	257	258	259	260	261	262	263	264	265	266	267	268	269	270	271	272	273	274	275	276	277	278	279	280	281	282	283	284	285	286	287	288	289	290	291	292	293	294	295	296	297	298	299	300	301	302	303	304	305	306	307	308	309	310	311	312	313	314	315	316	317	318	319	320	321	322	323	324	325	326	327	328	329	330	331	332	333	334	335	336	337	338	339	340	341	342	343	344	345	346	347	348	349	350	351	352	353	354	355	356	357	358	359	360	361	362	363	364	365	366	367	368	369	370	371	372	373	374	375	376	377	378	379	380	381	382	383	384	385	386	387	388	389	390	391	392	393	394	395	396	397	398	399	400	401	402	403	404	405	406	407	408	409	410	411	412	413	414	415	416	417	418	419	420	421	422	423	424	425	426	427	428	429	430	431	432	433	434	435	436	437	438	439	440	441	442	443	444	445	446	447	448	449	450	451	452	453	454	455	456	457	458	459	460	461	462	463	464	465	466	467	468	469	470	471	472	473	474	475	476	477	478	479	480	481	482	483	484	485	486	487	488	489	490	491	492	493	494	495	496	497	498	499	500
-----	-----	-----	-----	-----	-----	-----	-----	-----	-----	-----	-----	-----	-----	-----	-----	-----	-----	-----	-----	-----	-----	-----	-----	-----	-----	-----	-----	-----	-----	-----	-----	-----	-----	-----	-----	-----	-----	-----	-----	-----	-----	-----	-----	-----	-----	-----	-----	-----	-----	-----	-----	-----	-----	-----	-----	-----	-----	-----	-----	-----	-----	-----	-----	-----	-----	-----	-----	-----	-----	-----	-----	-----	-----	-----	-----	-----	-----	-----	-----	-----	-----	-----	-----	-----	-----	-----	-----	-----	-----	-----	-----	-----	-----	-----	-----	-----	-----	-----	-----	-----	-----	-----	-----	-----	-----	-----	-----	-----	-----	-----	-----	-----	-----	-----	-----	-----	-----	-----	-----	-----	-----	-----	-----	-----	-----	-----	-----	-----	-----	-----	-----	-----	-----	-----	-----	-----	-----	-----	-----	-----	-----	-----	-----	-----	-----	-----	-----	-----	-----	-----	-----	-----	-----	-----	-----	-----	-----	-----	-----	-----	-----	-----	-----	-----	-----	-----	-----	-----	-----	-----	-----	-----	-----	-----	-----	-----	-----	-----	-----	-----	-----	-----	-----	-----	-----	-----	-----	-----	-----	-----	-----	-----	-----	-----	-----	-----	-----	-----	-----	-----	-----	-----	-----	-----	-----	-----	-----	-----	-----	-----	-----	-----	-----	-----	-----	-----	-----	-----	-----	-----	-----	-----	-----	-----	-----	-----	-----	-----	-----	-----	-----	-----	-----	-----	-----	-----	-----	-----	-----	-----	-----	-----	-----	-----	-----	-----	-----	-----	-----	-----	-----	-----	-----	-----	-----	-----	-----	-----	-----	-----	-----	-----	-----	-----	-----	-----	-----	-----	-----	-----	-----	-----	-----	-----	-----	-----	-----	-----	-----	-----	-----	-----	-----	-----	-----	-----	-----	-----	-----	-----	-----	-----	-----	-----	-----	-----	-----	-----	-----	-----	-----	-----	-----	-----	-----	-----	-----	-----	-----	-----	-----	-----	-----	-----	-----	-----	-----	-----	-----	-----	-----	-----	-----	-----	-----	-----	-----	-----	-----	-----	-----	-----	-----	-----	-----	-----	-----	-----	-----	-----	-----	-----	-----	-----	-----	-----	-----	-----	-----	-----	-----	-----

Figure B-7. Test Case 3 (Nodes)

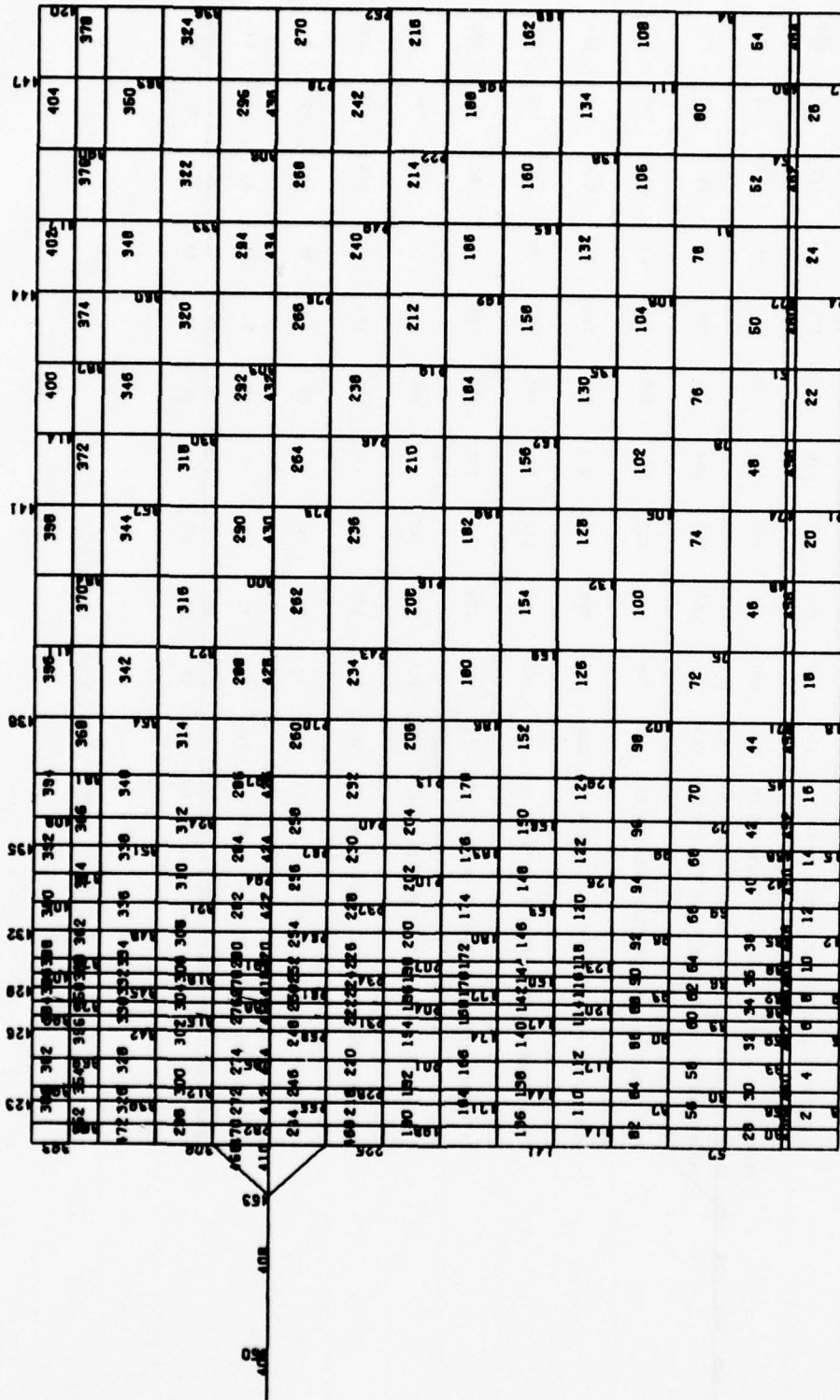

Figure B-9. Test Case 3 (Nodes and Elements)

GRID	1	0.00	0.00	0.00
GRID	2	.07	0.00	0.00
GRID	3	.15	0.00	0.00
GRID	4	.20	0.00	0.00
GRID	5	.30	0.00	0.00
GRID	6	.40	0.00	0.00
GRID	7	.45	0.00	0.00
GRID	8	.50	0.00	0.00
GRID	9	.55	0.00	0.00
GRID	10	.60	0.00	0.00
GRID	11	.65	0.00	0.00
GRID	12	.75	0.00	0.00
GRID	13	.85	0.00	0.00
GRID	14	.95	0.00	0.00
GRID	15	1.00	0.00	0.00
GRID	16	1.15	0.00	0.00
GRID	17	1.30	0.00	0.00

GRID	469	1.05	.17	0.00
GRID	469	1.15	.17	0.00
GRID	470	1.50	.17	0.00
GRID	471	1.50	.17	0.00
GRID	472	1.75	.17	0.00
GRID	473	2.00	.17	0.00
GRID	474	2.25	.17	0.00
GRID	475	2.50	.17	0.00
GRID	476	2.75	.17	0.00
GRID	477	3.00	.17	0.00
GRID	478	3.25	.17	0.00
GRID	479	3.50	.17	0.00
GRID	480	3.75	.17	0.00
GRID	481	4.00	.17	0.00

CQUAD2	1	1	1	2	30	29	0.000
CQUAD2	2	1	2	3	31	30	0.000
CQUAD2	3	2	3	4	32	31	0.000
CQUAD2	4	2	4	5	33	32	0.000

CQUAD2	5	2	5	6	34	33	0.000	
CQUAD2	6	2	6	7	35	34	0.000	
CQUAD2	399	4	413	414	442	441	0.000	
CQUAD2	400	4	414	415	443	442	0.000	
CQUAD2	401	4	415	416	444	443	0.000	
CQUAD2	402	4	416	417	445	444	0.000	
CQUAD2	403	4	417	418	446	445	0.000	
CQUAD2	404	4	418	419	447	446	0.000	
CQUAD2	405	4	419	420	448	447	0.000	
CBAR	406	5	449	450	0.00	1.00	0.00	1
CBAR	407	5	450	451	0.00	1.00	0.00	1
CBAR	408	5	451	452	0.00	1.00	0.00	1
CBAR	409	5	452	453	0.00	1.00	0.00	1
CBAR	410	7	453	281	0.00	1.00	0.00	1
CBAR	411	7	281	282	0.00	1.00	0.00	1
CBAR	412	7	282	283	0.00	1.00	0.00	1
CBAR	460	3	476	477	0.00	1.00	0.00	1
CBAR	461	3	477	478	0.00	1.00	0.00	1
CBAR	462	3	478	479	0.00	1.00	0.00	1
CBAR	463	3	479	480	0.00	1.00	0.00	1
CBAR	464	3	480	481	0.00	1.00	0.00	1
CBAR	465	6	253	453	1.00	0.00	0.00	1
CBAR	466	6	453	309	1.00	0.00	0.00	1
CBAR	467	6	197	225	1.00	0.00	0.00	1
CBAR	468	6	225	253	1.00	0.00	0.00	1
CBAR	469	6	253	281	1.00	0.00	0.00	1
CBAR	470	6	281	309	1.00	0.00	0.00	1
CBAR	471	6	309	337	1.00	0.00	0.00	1
CBAR	472	6	337	365	1.00	0.00	0.00	1
SPC1	100	15	28					
SPC1	101	15	56					
SPC1	102	15	84					

SPC1	103	15	112					
SFC1	104	15	140					
SFC1	105	15	168					
SPC1	106	15	196					
SPC1	107	15	224					
SFC1	108	15	252					
SPC1	109	15	280					
SPC1	110	15	308					
SFC1	111	15	336					
SPC1	112	15	364					
SFC1	113	15	392					
SPC1	114	15	420					
SFC1	115	15	448					
SPC1	116	15	481					
SPCAD0	99	100	101	102	103	104	105	106ABC10
+BC10	107	108	109	110	111	112	113	114ABC11
+BC11	115	115	500	501	502			
PQUAD2	1	1	.3740					
PQUAD2	2	2	.3740					
PQUAD2	3	3	.3740					
PQUAD2	4	4	.3740					
PBAR*		5		5	.1256637E+00		.1256637E-02QA8CDEF1	
*ABCDEF1	.1256637E-02		.4000000E+00					
PBAR*		6		6	.3141593E-01		.7853982E-04QA3CDEF2	
*ABCDEF2	.7853982E-04		.2000000E+00					
PBAR*		7		7	.1410251E-01		.1582665E-04QA3CDEF3	
*ABCDEF3	.1582665E-04		.1250000E+00					
PBAR*		8		8	.7086218E-02		.3998198E-05QA3CDEF4	
*ABCDEF4	.3998198E-05		.9500000E-01					
MAT1	1	3.0E7		.3200	.2800			
MAT1	2	1.0E7		.3000	.1500			
MAT1	3	3.5E6		.2800	.0660			
MAT1	4	3.5E6		.2800	.0660			

MAT1	5	3.0E7		.3200	.2800	
MAT1	6	3.0E7		.3200	.2800	
MAT1	7	3.0E7		.3200	.2800	
MAT1	8	3.0E7		.3200	.2800	
SPC1	500	123456	+49	482		
SPC1	501	0	1	THRU	+61	
SPC1	502	2	450	451		
RFORCE*		20		482		
+RFORCE1	1.0000	0.0000	0.0000			.>10007E+03RFORCE1
GRAV*		21				
+GRAV1	-1.0000	0.0000			.300000E+00	0.00000GRAV1
PARAM	HTMASS	.002000				
PARAM	GRDPNT		J			
LOAD	30	1.0000	1.0000	20	1.0000	21
GRID	+82		0.000	5.500	0.000	
ENDDATA						

309	310	311	312	313	314	315	316	317	318	319	320	321	322	323	324	325	326	327	328	329	330
287	288	289	290	291	292	293	294	295	296	297	298	299	300	301	302	303	304	305	306	307	308
265	266	267	268	269	270	271	272	273	274	275	276	277	278	279	280	281	282	283	284	285	286
243	244	245	246	247	248	249	250	251	252	253	254	255	256	257	258	259	260	261	262	263	264
221	222	223	224	225	226	227	228	229	230	231	232	233	234	235	236	237	238	239	240	241	242
203	204	205	206	207	208	209	210	211	212	213	214	215	216	217	218	219	220	221	222	223	224
178	179	180	181	182	183	184	185	186	187	188	189	190	191	192	193	194	195	196	197	198	199
161	162	163	164	165	166	167	168	169	170	171	172	173	174	175	176	177	178	179	180	181	182
134	135	136	137	138	139	140	141	142	143	144	145	146	147	148	149	150	151	152	153	154	155
112	113	114	115	116	117	118	119	120	121	122	123	124	125	126	127	128	129	130	131	132	133
90	91	92	93	94	95	96	97	98	99	100	101	102	103	104	105	106	107	108	109	110	111
68	69	70	71	72	73	74	75	76	77	78	79	80	81	82	83	84	85	86	87	88	89
46	47	48	49	50	51	52	53	54	55	56	57	58	59	60	61	62	63	64	65	66	67
24	25	26	27	28	29	30	31	32	33	34	35	36	37	38	39	40	41	42	43	44	45
2	3	4	5	6	7	8	9	10	11	12	13	14	15	16	17	18	19	20	21	22	23

Figure B-10. Test Case 4 (Nodes and Elements)

AFFDL-TR-77-49

APPENDIX C

NASTRAN PROGRAM LISTINGS FROM A SORTED INPUT

DECEMBER 22, 1976 NASTRAN 9/16/74 PAGE 1

NASTRAN EXECUTIVE CONTROL DECK ECHO

ID ROVAC, SCHWARTZ
APP DISPLACEMENT
SOL 1, 0
DIAG 13
TIME 100
CEND

C A S E C O N T R O L D E C K E C H O

CARD COUNT

1 TITLE=K.P.SCHWARTZ, 60X SIZE #7D (0 DEG.=3,+45,-45,90 DEG. LAYERS) AS

2 OUTPUT

3 LOAD = ALL

4 SPCFORCES = ALL

5 ELFORCES = ALL

6 STRESSES = ALL

7 DISPLACEMENT(PRINT,PUNCH) = ALL

8 SUBCASE 1

9 SUBTITLE= ACTUAL AIR CYCLE VANE (COMBINED LOADS)

10 LABEL=RVAC,RUN TEST CASE #2 AFFDL/FEHC, SCHWARTZ

11 LOAD= 30

12 SPC=99

13 OUTPUT(PLOT)

14 SET 1=ALL

15 PLOTTER NASTPLT (0,1)

16 ORTHOGRAPHIC PROJECTION

17 VIEW 90.0,90.0,0.0

18 FIND SCALE, ORIGIN 1

19 MAXIMUM DEFORMATION= .2

20 PLOT STATIC DEFORMATION 0,1,SET 1,SHAPE

21 PLOT STATIC DEFORMATION 1,SET 1,SHAPE

22 BEGIN BULK

*** USER INFORMATION MESSAGE 207, BULK DATA NOT SORTED,XSORT WILL RE-ORDER DECK.

S O R T E D B U L K D A T A E C H O

CARD COUNT	1	2	3	4	5	6	7	8	9	10
1-	CBAR 433	433	477	478	479	.00	1.00	.00	1	1
2-	CBAR 434	434	478	479	480	.00	1.00	.00	1	1
3-	CBAR 435	435	479	480	481	.00	1.00	.00	1	1
4-	CBAR 436	436	480	481	309	.00	1.00	.00	1	1
5-	CBAR 437	437	481	309	310	.00	1.00	.00	1	1
6-	CBAR 438	438	309	310	311	.00	1.00	.00	1	1
7-	CBAR 439	439	310	311	312	.00	1.00	.00	1	1
8-	CBAR 440	440	311	312	313	.00	1.00	.00	1	1
9-	CBAR 441	441	312	313	314	.00	1.00	.00	1	1
10-	CBAR 442	442	313	314	315	.00	1.00	.00	1	1
11-	CBAR 443	443	314	315	316	.00	1.00	.00	1	1
12-	CBAR 444	444	315	316	317	.00	1.00	.00	1	1
13-	CBAR 445	445	316	317	318	.00	1.00	.00	1	1
14-	CBAR 446	446	317	318	319	.00	1.00	.00	1	1
15-	CBAR 447	447	318	319	320	.00	1.00	.00	1	1
16-	CBAR 448	448	319	320	321	.00	1.00	.00	1	1
17-	CBAR 449	449	320	321	322	.00	1.00	.00	1	1
18-	CBAR 450	450	321	322	323	.00	1.00	.00	1	1
19-	CBAR 451	451	322	323	324	.00	1.00	.00	1	1
20-	CBAR 452	452	323	324	325	.00	1.00	.00	1	1
21-	CBAR 453	453	324	325	326	.00	1.00	.00	1	1
22-	CBAR 454	454	325	326	327	.00	1.00	.00	1	1
23-	CBAR 455	455	326	327	328	.00	1.00	.00	1	1
24-	CBAR 456	456	327	328	329	.00	1.00	.00	1	1
25-	CBAR 457	457	328	329	330	.00	1.00	.00	1	1
26-	CBAR 458	458	329	330	331	.00	1.00	.00	1	1
27-	CBAR 459	459	330	331	332	.00	1.00	.00	1	1
28-	CBAR 460	460	331	332	333	.00	1.00	.00	1	1
29-	CBAR 461	461	332	333	334	.00	1.00	.00	1	1
30-	CBAR 462	462	333	334	335	.00	1.00	.00	1	1
31-	CBAR 463	463	334	335	336	.00	1.00	.00	1	1
32-	CBAR 464	464	335	336	30	.00	1.00	.00	1	1
33-	CBAR 465	465	336	30	31	.00	1.00	.00	1	1
34-	CBAR 466	466	30	31	32	.00	1.00	.00	1	1
35-	CBAR 467	467	31	32	33	.00	1.00	.00	1	1
36-	CBAR 468	468	32	33	34	.00	1.00	.00	1	1
37-	CBAR 469	469	33	34	35	.00	1.00	.00	1	1
38-	CBAR 470	470	34	35	36	.00	1.00	.00	1	1
39-	CBAR 471	471	35	36	37	.00	1.00	.00	1	1
40-	CBAR 472	472	36	37	38	.00	1.00	.00	1	1
41-	CBAR 473	473	37	38	39	.00	1.00	.00	1	1
42-	CBAR 474	474	38	39	40	.00	1.00	.00	1	1
43-	CBAR 475	475	39	40	41	.00	1.00	.00	1	1
44-	CBAR 476	476	40	41	42	.00	1.00	.00	1	1
45-	CBAR 477	477	41	42	43	.00	1.00	.00	1	1
46-	CBAR 478	478	42	43	44	.00	1.00	.00	1	1
47-	CBAR 479	479	43	44	45	.00	1.00	.00	1	1
48-	CBAR 480	480	44	45	46	.00	1.00	.00	1	1
49-	CBAR 481	481	45	46	47	.00	1.00	.00	1	1
50-	CBAR 492	492	46	47		.00	1.00	.00	1	1

CARD COUNT	1	2	3	4	5	6	7	8	9	10
51-	CBAR	483	47	48	.00	.00	1.00	.00	.00	.00
52-	CBAR	484	48	49	.00	1.00	.00	.00	.00	.00
53-	CBAR	485	49	50	.00	.00	1.00	.00	.00	.00
54-	CBAR	486	50	51	.00	.00	.00	1.00	.00	.00
55-	CBAR	487	51	52	.00	.00	.00	.00	1.00	.00
56-	CBAR	488	52	53	.00	.00	.00	.00	.00	1.00
57-	CBAR	489	53	54	.00	.00	.00	.00	.00	.00
58-	CBAR	490	54	55	.00	.00	.00	.00	.00	.00
59-	CBAR	491	55	56	.00	.00	.00	.00	.00	.00
60-	CBAR	492	56	57	.00	.00	.00	.00	.00	.00
61-	CBAR	493	57	58	1.00	.00	.00	.00	.00	.00
62-	CBAR	494	58	59	1.00	.00	.00	.00	.00	.00
63-	CBAR	495	59	60	1.00	.00	.00	.00	.00	.00
64-	CBAR	496	60	61	1.00	.00	.00	.00	.00	.00
65-	CBAR	497	61	62	1.00	.00	.00	.00	.00	.00
66-	CBAR	498	62	63	1.00	.00	.00	.00	.00	.00
67-	CBAR	499	63	64	1.00	.00	.00	.00	.00	.00
68-	CQUAD2	1	1	2	30	29	.00	.00	.00	.00
69-	CQUAD2	2	2	3	31	30	0.000	0.000	0.000	0.000
70-	CQUAD2	3	3	4	32	31	0.000	0.000	0.000	0.000
71-	CQUAD2	4	4	5	33	32	0.000	0.000	0.000	0.000
72-	CQUAD2	5	5	6	34	33	0.000	0.000	0.000	0.000
73-	CQUAD2	6	6	7	35	34	0.000	0.000	0.000	0.000
74-	CQUAD2	7	7	8	36	35	0.000	0.000	0.000	0.000
75-	CQUAD2	8	8	9	37	36	0.000	0.000	0.000	0.000
76-	CQUAD2	9	9	10	38	37	0.000	0.000	0.000	0.000
77-	CQUAD2	10	10	11	39	38	0.000	0.000	0.000	0.000
78-	CQUAD2	11	11	12	40	39	0.000	0.000	0.000	0.000
79-	CQUAD2	12	12	13	41	40	0.000	0.000	0.000	0.000
80-	CQUAD2	13	13	14	42	41	0.000	0.000	0.000	0.000
81-	CQUAD2	14	14	15	43	42	0.000	0.000	0.000	0.000
82-	CQUAD2	15	15	16	44	43	0.000	0.000	0.000	0.000
83-	CQUAD2	16	16	17	45	44	0.000	0.000	0.000	0.000
84-	CQUAD2	17	17	18	46	45	0.000	0.000	0.000	0.000
85-	CQUAD2	18	18	19	47	46	0.000	0.000	0.000	0.000
86-	CQUAD2	19	19	20	48	47	0.000	0.000	0.000	0.000
87-	CQUAD2	20	20	21	49	48	0.000	0.000	0.000	0.000
88-	CQUAD2	21	21	22	50	49	0.000	0.000	0.000	0.000
89-	CQUAD2	22	22	23	51	50	0.000	0.000	0.000	0.000
90-	CQUAD2	23	23	24	52	51	0.000	0.000	0.000	0.000
91-	CQUAD2	24	24	25	53	52	0.000	0.000	0.000	0.000
92-	CQUAD2	25	25	26	54	53	0.000	0.000	0.000	0.000
93-	CQUAD2	26	26	27	55	54	0.000	0.000	0.000	0.000
94-	CQUAD2	27	27	28	56	55	0.000	0.000	0.000	0.000
95-	CQUAD2	28	28	29	57	56	0.000	0.000	0.000	0.000
96-	CQUAD2	29	29	30	58	57	0.000	0.000	0.000	0.000
97-	CQUAD2	30	30	31	59	58	0.000	0.000	0.000	0.000
98-	CQUAD2	31	31	32	60	59	0.000	0.000	0.000	0.000
99-	CQUAD2	32	32	33	61	60	0.000	0.000	0.000	0.000
100-	CQUAD2	33	33	34	62	61	0.000	0.000	0.000	0.000

CARD COUNT	1	2	3	4	5	6	7	8	9	10
101-	CQUAD2 34	2	35	64	63	0.000	0.000	0.000	0.000	0.000
102-	CQUAD2 35	2	36	65	64	0.000	0.000	0.000	0.000	0.000
103-	CQUAD2 36	2	37	66	65	0.000	0.000	0.000	0.000	0.000
104-	CQUAD2 37	2	38	67	66	0.000	0.000	0.000	0.000	0.000
105-	CQUAD2 38	2	39	68	67	0.000	0.000	0.000	0.000	0.000
106-	CQUAD2 39	3	40	69	68	0.000	0.000	0.000	0.000	0.000
107-	CQUAD2 40	3	41	70	69	0.000	0.000	0.000	0.000	0.000
108-	CQUAD2 41	3	42	71	70	0.000	0.000	0.000	0.000	0.000
109-	CQUAD2 42	3	43	72	71	0.000	0.000	0.000	0.000	0.000
110-	CQUAD2 43	3	44	73	72	0.000	0.000	0.000	0.000	0.000
111-	CQUAD2 44	3	45	74	73	0.000	0.000	0.000	0.000	0.000
112-	CQUAD2 45	3	46	75	74	0.000	0.000	0.000	0.000	0.000
113-	CQUAD2 46	3	47	76	75	0.000	0.000	0.000	0.000	0.000
114-	CQUAD2 47	4	48	77	76	0.000	0.000	0.000	0.000	0.000
115-	CQUAD2 48	4	49	78	77	0.000	0.000	0.000	0.000	0.000
116-	CQUAD2 49	4	50	79	78	0.000	0.000	0.000	0.000	0.000
117-	CQUAD2 50	4	51	80	79	0.000	0.000	0.000	0.000	0.000
118-	CQUAD2 51	4	52	81	80	0.000	0.000	0.000	0.000	0.000
119-	CQUAD2 52	4	53	82	81	0.000	0.000	0.000	0.000	0.000
120-	CQUAD2 53	4	54	83	82	0.000	0.000	0.000	0.000	0.000
121-	CQUAD2 54	4	55	84	83	0.000	0.000	0.000	0.000	0.000
122-	CQUAD2 55	1	57	86	85	0.000	0.000	0.000	0.000	0.000
123-	CQUAD2 56	1	58	87	86	0.000	0.000	0.000	0.000	0.000
124-	CQUAD2 57	2	59	88	87	0.000	0.000	0.000	0.000	0.000
125-	CQUAD2 58	2	60	89	88	0.000	0.000	0.000	0.000	0.000
126-	CQUAD2 59	2	61	90	89	0.000	0.000	0.000	0.000	0.000
127-	CQUAD2 60	2	62	91	90	0.000	0.000	0.000	0.000	0.000
128-	CQUAD2 61	2	63	92	91	0.000	0.000	0.000	0.000	0.000
129-	CQUAD2 62	2	64	93	92	0.000	0.000	0.000	0.000	0.000
130-	CQUAD2 63	2	65	94	93	0.000	0.000	0.000	0.000	0.000
131-	CQUAD2 64	2	66	95	94	0.000	0.000	0.000	0.000	0.000
132-	CQUAD2 65	3	67	96	95	0.000	0.000	0.000	0.000	0.000
133-	CQUAD2 66	3	68	97	96	0.000	0.000	0.000	0.000	0.000
134-	CQUAD2 67	3	69	98	97	0.000	0.000	0.000	0.000	0.000
135-	CQUAD2 68	3	70	99	98	0.000	0.000	0.000	0.000	0.000
136-	CQUAD2 69	3	71	100	99	0.000	0.000	0.000	0.000	0.000
137-	CQUAD2 70	3	72	101	100	0.000	0.000	0.000	0.000	0.000
138-	CQUAD2 71	3	73	102	101	0.000	0.000	0.000	0.000	0.000
139-	CQUAD2 72	3	74	103	102	0.000	0.000	0.000	0.000	0.000
140-	CQUAD2 73	3	75	104	103	0.000	0.000	0.000	0.000	0.000
141-	CQUAD2 74	4	76	105	104	0.000	0.000	0.000	0.000	0.000
142-	CQUAD2 75	4	77	106	105	0.000	0.000	0.000	0.000	0.000
143-	CQUAD2 76	4	78	107	106	0.000	0.000	0.000	0.000	0.000
144-	CQUAD2 77	4	79	108	107	0.000	0.000	0.000	0.000	0.000
145-	CQUAD2 78	4	80	109	108	0.000	0.000	0.000	0.000	0.000
146-	CQUAD2 79	4	81	110	109	0.000	0.000	0.000	0.000	0.000
147-	CQUAD2 80	4	82	111	110	0.000	0.000	0.000	0.000	0.000
148-	CQUAD2 81	4	83	112	111	0.000	0.000	0.000	0.000	0.000
149-	CQUAD2 82	1	85	114	113	0.000	0.000	0.000	0.000	0.000
150-	CQUAD2 83	1	86	115	114	0.000	0.000	0.000	0.000	0.000

S O R T E D B U L K D A T A E C H O

CARD COUNT	1	2	3	4	5	6	7	8	9	10
151-	COUAD2 64	87	88	116	115	116	0.000	0.000		
152-	COUAD2 65	88	89	117	116	117	0.000	0.000		
153-	COUAD2 66	89	90	118	117	118	0.000	0.000		
154-	COUAD2 67	90	91	119	118	119	0.000	0.000		
155-	COUAD2 68	91	92	120	119	120	0.000	0.000		
156-	COUAD2 69	92	93	121	120	121	0.000	0.000		
157-	COUAD2 70	93	94	122	121	122	0.000	0.000		
158-	COUAD2 71	94	95	123	122	123	0.000	0.000		
159-	COUAD2 72	95	96	124	123	124	0.000	0.000		
160-	COUAD2 73	96	97	125	124	125	0.000	0.000		
161-	COUAD2 74	97	98	126	125	126	0.000	0.000		
162-	COUAD2 75	98	99	127	126	127	0.000	0.000		
163-	COUAD2 76	99	100	128	127	128	0.000	0.000		
164-	COUAD2 77	100	101	129	128	129	0.000	0.000		
165-	COUAD2 78	101	102	130	129	130	0.000	0.000		
166-	COUAD2 79	102	103	131	130	131	0.000	0.000		
167-	COUAD2 80	103	104	132	131	132	0.000	0.000		
168-	COUAD2 81	104	105	133	132	133	0.000	0.000		
169-	COUAD2 82	105	106	134	133	134	0.000	0.000		
170-	COUAD2 83	106	107	135	134	135	0.000	0.000		
171-	COUAD2 84	107	108	136	135	136	0.000	0.000		
172-	COUAD2 85	108	109	137	136	137	0.000	0.000		
173-	COUAD2 86	109	110	138	137	138	0.000	0.000		
174-	COUAD2 87	110	111	139	138	139	0.000	0.000		
175-	COUAD2 88	111	112	140	139	140	0.000	0.000		
176-	COUAD2 89	112	113	141	140	141	0.000	0.000		
177-	COUAD2 90	113	114	142	141	142	0.000	0.000		
178-	COUAD2 91	114	115	143	142	143	0.000	0.000		
179-	COUAD2 92	115	116	144	143	144	0.000	0.000		
180-	COUAD2 93	116	117	145	144	145	0.000	0.000		
181-	COUAD2 94	117	118	146	145	146	0.000	0.000		
182-	COUAD2 95	118	119	147	146	147	0.000	0.000		
183-	COUAD2 96	119	120	148	147	148	0.000	0.000		
184-	COUAD2 97	120	121	149	148	149	0.000	0.000		
185-	COUAD2 98	121	122	150	149	150	0.000	0.000		
186-	COUAD2 99	122	123	151	150	151	0.000	0.000		
187-	COUAD2 100	123	124	152	151	152	0.000	0.000		
188-	COUAD2 101	124	125	153	152	153	0.000	0.000		
189-	COUAD2 102	125	126	154	153	154	0.000	0.000		
190-	COUAD2 103	126	127	155	154	155	0.000	0.000		
191-	COUAD2 104	127	128	156	155	156	0.000	0.000		
192-	COUAD2 105	128	129	157	156	157	0.000	0.000		
193-	COUAD2 106	129	130	158	157	158	0.000	0.000		
194-	COUAD2 107	130	131	159	158	159	0.000	0.000		
195-	COUAD2 108	131	132	160	159	160	0.000	0.000		
196-	COUAD2 109	132	133	161	160	161	0.000	0.000		
197-	COUAD2 110	133	134	162	161	162	0.000	0.000		
198-	COUAD2 111	134	135	163	162	163	0.000	0.000		
199-	COUAD2 112	135	136	164	163	164	0.000	0.000		
200-	COUAD2 113	136	137	165	164	165	0.000	0.000		

CARD COUNT	1	2	3	4	5	6	7	8	9	10
201-	CQUAD2 134	139	167	166	0.000	0.000	0.000	0.000
202-	CQUAD2 135	4	4	139	140	168	0.000	0.000	0.000	0.000
203-	CQUAD2 136	1	1	141	142	170	0.000	0.000	0.000	0.000
204-	CQUAD2 137	1	1	142	143	171	0.000	0.000	0.000	0.000
205-	CQUAD2 138	2	2	143	144	172	0.000	0.000	0.000	0.000
206-	CQUAD2 139	2	2	144	145	173	0.000	0.000	0.000	0.000
207-	CQUAD2 140	2	2	145	146	174	0.000	0.000	0.000	0.000
208-	CQUAD2 141	2	2	146	147	175	0.000	0.000	0.000	0.000
209-	CQUAD2 142	2	2	147	148	176	0.000	0.000	0.000	0.000
210-	CQUAD2 143	2	2	148	149	177	0.000	0.000	0.000	0.000
211-	CQUAD2 144	2	2	149	150	178	0.000	0.000	0.000	0.000
212-	CQUAD2 145	2	2	150	151	179	0.000	0.000	0.000	0.000
213-	CQUAD2 146	3	3	151	152	180	0.000	0.000	0.000	0.000
214-	CQUAD2 147	3	3	152	153	181	0.000	0.000	0.000	0.000
215-	CQUAD2 148	3	3	153	154	182	0.000	0.000	0.000	0.000
216-	CQUAD2 149	3	3	154	155	183	0.000	0.000	0.000	0.000
217-	CQUAD2 150	3	3	155	156	184	0.000	0.000	0.000	0.000
218-	CQUAD2 151	3	3	156	157	185	0.000	0.000	0.000	0.000
219-	CQUAD2 152	3	3	157	158	186	0.000	0.000	0.000	0.000
220-	CQUAD2 153	3	3	158	159	187	0.000	0.000	0.000	0.000
221-	CQUAD2 154	3	3	159	160	188	0.000	0.000	0.000	0.000
222-	CQUAD2 155	4	4	160	161	189	0.000	0.000	0.000	0.000
223-	CQUAD2 156	4	4	161	162	190	0.000	0.000	0.000	0.000
224-	CQUAD2 157	4	4	162	163	191	0.000	0.000	0.000	0.000
225-	CQUAD2 158	4	4	163	164	192	0.000	0.000	0.000	0.000
226-	CQUAD2 159	4	4	164	165	193	0.000	0.000	0.000	0.000
227-	CQUAD2 160	4	4	165	166	194	0.000	0.000	0.000	0.000
228-	CQUAD2 161	4	4	166	167	195	0.000	0.000	0.000	0.000
229-	CQUAD2 162	4	4	167	168	196	0.000	0.000	0.000	0.000
230-	CQUAD2 163	1	1	169	170	198	0.000	0.000	0.000	0.000
231-	CQUAD2 164	1	1	170	171	199	0.000	0.000	0.000	0.000
232-	CQUAD2 165	2	2	171	172	200	0.000	0.000	0.000	0.000
233-	CQUAD2 166	2	2	172	173	201	0.000	0.000	0.000	0.000
234-	CQUAD2 167	2	2	173	174	202	0.000	0.000	0.000	0.000
235-	CQUAD2 168	2	2	174	175	203	0.000	0.000	0.000	0.000
236-	CQUAD2 169	2	2	175	176	204	0.000	0.000	0.000	0.000
237-	CQUAD2 170	2	2	176	177	205	0.000	0.000	0.000	0.000
238-	CQUAD2 171	2	2	177	178	206	0.000	0.000	0.000	0.000
239-	CQUAD2 172	2	2	178	179	207	0.000	0.000	0.000	0.000
240-	CQUAD2 173	3	3	179	180	208	0.000	0.000	0.000	0.000
241-	CQUAD2 174	3	3	180	181	209	0.000	0.000	0.000	0.000
242-	CQUAD2 175	3	3	181	182	210	0.000	0.000	0.000	0.000
243-	CQUAD2 176	3	3	182	183	211	0.000	0.000	0.000	0.000
244-	CQUAD2 177	3	3	183	184	212	0.000	0.000	0.000	0.000
245-	CQUAD2 178	3	3	184	185	213	0.000	0.000	0.000	0.000
246-	CQUAD2 179	3	3	185	186	214	0.000	0.000	0.000	0.000
247-	CQUAD2 180	3	3	186	187	215	0.000	0.000	0.000	0.000
248-	CQUAD2 181	3	3	187	188	216	0.000	0.000	0.000	0.000
249-	CQUAD2 182	4	4	188	189	217	0.000	0.000	0.000	0.000
250-	CQUAD2 183	4	4	189	190	218	0.000	0.000	0.000	0.000

CARD COUNT	1	2	3	4	5	6	7	8	9	10
251-	CQUAD2 184	4	190	191	191	219	218	0.000		
252-	CQUAD2 185	4	191	192	192	220	219	0.000		
253-	CQUAD2 186	4	192	193	193	221	220	0.000		
254-	CQUAD2 187	4	193	194	194	222	221	0.000		
255-	CQUAD2 188	4	194	195	195	223	222	0.000		
256-	CQUAD2 189	4	195	196	196	224	223	0.000		
257-	CQUAD2 190	4	196	197	197	225	224	0.000		
258-	CQUAD2 191	1	197	198	198	226	225	0.000		
259-	CQUAD2 192	2	198	199	199	227	226	0.000		
260-	CQUAD2 193	2	199	200	200	228	227	0.000		
261-	CQUAD2 194	2	200	201	201	229	228	0.000		
262-	CQUAD2 195	2	201	202	202	230	229	0.000		
263-	CQUAD2 196	2	202	203	203	231	230	0.000		
264-	CQUAD2 197	2	203	204	204	232	231	0.000		
265-	CQUAD2 198	2	204	205	205	233	232	0.000		
266-	CQUAD2 199	2	205	206	206	234	233	0.000		
267-	CQUAD2 200	3	206	207	207	235	234	0.000		
268-	CQUAD2 201	3	207	208	208	236	235	0.000		
269-	CQUAD2 202	3	208	209	209	237	236	0.000		
270-	CQUAD2 203	3	209	210	210	238	237	0.000		
271-	CQUAD2 204	3	210	211	211	239	238	0.000		
272-	CQUAD2 205	3	211	212	212	240	239	0.000		
273-	CQUAD2 206	3	212	213	213	241	240	0.000		
274-	CQUAD2 207	3	213	214	214	242	241	0.000		
275-	CQUAD2 208	3	214	215	215	243	242	0.000		
276-	CQUAD2 209	4	215	216	216	244	243	0.000		
277-	CQUAD2 210	4	216	217	217	245	244	0.000		
278-	CQUAD2 211	4	217	218	218	246	245	0.000		
279-	CQUAD2 212	4	218	219	219	247	246	0.000		
280-	CQUAD2 213	4	219	220	220	248	247	0.000		
281-	CQUAD2 214	4	220	221	221	249	248	0.000		
282-	CQUAD2 215	4	221	222	222	250	249	0.000		
283-	CQUAD2 216	4	222	223	223	251	250	0.000		
284-	CQUAD2 217	4	223	224	224	252	251	0.000		
285-	CQUAD2 218	1	224	225	225	253	252	0.000		
286-	CQUAD2 219	2	225	226	226	254	253	0.000		
287-	CQUAD2 220	2	226	227	227	255	254	0.000		
288-	CQUAD2 221	2	227	228	228	256	255	0.000		
289-	CQUAD2 222	2	228	229	229	257	256	0.000		
290-	CQUAD2 223	2	229	230	230	258	257	0.000		
291-	CQUAD2 224	2	230	231	231	259	258	0.000		
292-	CQUAD2 225	2	231	232	232	260	259	0.000		
293-	CQUAD2 226	2	232	233	233	261	260	0.000		
294-	CQUAD2 227	2	233	234	234	262	261	0.000		
295-	CQUAD2 228	3	234	235	235	263	262	0.000		
296-	CQUAD2 229	3	235	236	236	264	263	0.000		
297-	CQUAD2 230	3	236	237	237	265	264	0.000		
298-	CQUAD2 231	3	237	238	238	266	265	0.000		
299-	CQUAD2 232	3	238	239	239	267	266	0.000		
300-	CQUAD2 233	3	239	240	240	268	267	0.000		

CARD	COUNT	1	2	3	4	5	6	7	8	9	10
301-	CQUAD2	234	242	243	271	270	0.000	0.000	0.000	0.000	0.000
302-	CQUAD2	235	243	244	272	271	0.000	0.000	0.000	0.000	0.000
303-	CQUAD2	236	244	245	273	272	0.000	0.000	0.000	0.000	0.000
304-	CQUAD2	237	245	246	274	273	0.000	0.000	0.000	0.000	0.000
305-	CQUAD2	238	246	247	275	274	0.000	0.000	0.000	0.000	0.000
306-	CQUAD2	239	247	248	276	275	0.000	0.000	0.000	0.000	0.000
307-	CQUAD2	240	248	249	277	276	0.000	0.000	0.000	0.000	0.000
308-	CQUAD2	241	249	250	278	277	0.000	0.000	0.000	0.000	0.000
309-	CQUAD2	242	250	251	279	278	0.000	0.000	0.000	0.000	0.000
310-	CQUAD2	243	251	252	280	279	0.000	0.000	0.000	0.000	0.000
311-	CQUAD2	244	252	253	281	280	0.000	0.000	0.000	0.000	0.000
312-	CQUAD2	245	253	254	282	281	0.000	0.000	0.000	0.000	0.000
313-	CQUAD2	246	254	255	283	282	0.000	0.000	0.000	0.000	0.000
314-	CQUAD2	247	255	256	284	283	0.000	0.000	0.000	0.000	0.000
315-	CQUAD2	248	256	257	285	284	0.000	0.000	0.000	0.000	0.000
316-	CQUAD2	249	257	258	286	285	0.000	0.000	0.000	0.000	0.000
317-	CQUAD2	250	258	259	287	286	0.000	0.000	0.000	0.000	0.000
318-	CQUAD2	251	259	260	288	287	0.000	0.000	0.000	0.000	0.000
319-	CQUAD2	252	260	261	289	288	0.000	0.000	0.000	0.000	0.000
320-	CQUAD2	253	261	262	290	289	0.000	0.000	0.000	0.000	0.000
321-	CQUAD2	254	262	263	291	290	0.000	0.000	0.000	0.000	0.000
322-	CQUAD2	255	263	264	292	291	0.000	0.000	0.000	0.000	0.000
323-	CQUAD2	256	264	265	293	292	0.000	0.000	0.000	0.000	0.000
324-	CQUAD2	257	265	266	294	293	0.000	0.000	0.000	0.000	0.000
325-	CQUAD2	258	266	267	295	294	0.000	0.000	0.000	0.000	0.000
326-	CQUAD2	259	267	268	296	295	0.000	0.000	0.000	0.000	0.000
327-	CQUAD2	260	268	269	297	296	0.000	0.000	0.000	0.000	0.000
328-	CQUAD2	261	269	270	298	297	0.000	0.000	0.000	0.000	0.000
329-	CQUAD2	262	270	271	299	298	0.000	0.000	0.000	0.000	0.000
330-	CQUAD2	263	271	272	300	299	0.000	0.000	0.000	0.000	0.000
331-	CQUAD2	264	272	273	301	300	0.000	0.000	0.000	0.000	0.000
332-	CQUAD2	265	273	274	302	301	0.000	0.000	0.000	0.000	0.000
333-	CQUAD2	266	274	275	303	302	0.000	0.000	0.000	0.000	0.000
334-	CQUAD2	267	275	276	304	303	0.000	0.000	0.000	0.000	0.000
335-	CQUAD2	268	276	277	305	304	0.000	0.000	0.000	0.000	0.000
336-	CQUAD2	269	277	278	306	305	0.000	0.000	0.000	0.000	0.000
337-	CQUAD2	270	278	279	307	306	0.000	0.000	0.000	0.000	0.000
338-	CQUAD2	271	279	280	308	307	0.000	0.000	0.000	0.000	0.000
339-	CQUAD2	272	280	281	309	308	0.000	0.000	0.000	0.000	0.000
340-	CQUAD2	273	281	282	310	309	0.000	0.000	0.000	0.000	0.000
341-	CQUAD2	274	282	283	311	310	0.000	0.000	0.000	0.000	0.000
342-	CQUAD2	275	283	284	312	311	0.000	0.000	0.000	0.000	0.000
343-	CQUAD2	276	284	285	313	312	0.000	0.000	0.000	0.000	0.000
344-	CQUAD2	277	285	286	314	313	0.000	0.000	0.000	0.000	0.000
345-	CQUAD2	278	286	287	315	314	0.000	0.000	0.000	0.000	0.000
346-	CQUAD2	279	287	288	316	315	0.000	0.000	0.000	0.000	0.000
347-	CQUAD2	280	288	289	317	316	0.000	0.000	0.000	0.000	0.000
348-	CQUAD2	281	289	290	318	317	0.000	0.000	0.000	0.000	0.000
349-	CQUAD2	282	290	291	319	318	0.000	0.000	0.000	0.000	0.000
350-	CQUAD2	283	291	292	320	319	0.000	0.000	0.000	0.000	0.000
		284	292	293	321	320	0.000	0.000	0.000	0.000	0.000
		285	293	294	322	321	0.000	0.000	0.000	0.000	0.000
		286	294	295	323	322	0.000	0.000	0.000	0.000	0.000

CARD COUNT	1	2	3	4	5	6	7	8	9	10
351-	QUAD2 294	294	295	295	295	323	322	0.000		
352-	QUAD2 285	295	295	296	296	323	323	0.000		
353-	QUAD2 286	296	296	297	297	324	324	0.000		
354-	QUAD2 287	297	297	298	298	325	325	0.000		
355-	QUAD2 288	298	298	299	299	326	326	0.000		
356-	QUAD2 289	299	299	300	300	327	327	0.000		
357-	QUAD2 290	300	300	301	301	328	328	0.000		
358-	QUAD2 291	301	301	302	302	329	329	0.000		
359-	QUAD2 292	302	302	303	303	330	330	0.000		
360-	QUAD2 293	303	303	304	304	331	331	0.000		
361-	QUAD2 294	304	304	305	305	332	332	0.000		
362-	QUAD2 295	305	305	306	306	333	333	0.000		
363-	QUAD2 296	306	306	307	307	334	334	0.000		
364-	QUAD2 297	307	307	308	308	335	335	0.000		
365-	QUAD2 298	308	309	310	310	336	336	0.000		
366-	QUAD2 299	309	310	311	311	337	337	0.000		
367-	QUAD2 300	310	311	312	312	338	338	0.000		
368-	QUAD2 301	311	312	313	313	339	339	0.000		
369-	QUAD2 302	312	313	314	314	340	340	0.000		
370-	QUAD2 303	313	314	315	315	341	341	0.000		
371-	QUAD2 304	314	315	316	316	342	342	0.000		
372-	QUAD2 305	315	316	317	317	343	343	0.000		
373-	QUAD2 306	316	317	318	318	344	344	0.000		
374-	QUAD2 307	317	318	319	319	345	345	0.000		
375-	QUAD2 308	318	319	320	320	346	346	0.000		
376-	QUAD2 309	319	320	321	321	347	347	0.000		
377-	QUAD2 310	320	321	322	322	348	348	0.000		
378-	QUAD2 311	321	322	323	323	349	349	0.000		
379-	QUAD2 312	322	323	324	324	350	350	0.000		
380-	QUAD2 313	323	324	325	325	351	351	0.000		
381-	QUAD2 314	324	325	326	326	352	352	0.000		
382-	QUAD2 315	325	326	327	327	353	353	0.000		
383-	QUAD2 316	326	327	328	328	354	354	0.000		
384-	QUAD2 317	327	328	329	329	355	355	0.000		
385-	QUAD2 318	328	329	330	330	356	356	0.000		
386-	QUAD2 319	329	330	331	331	357	357	0.000		
387-	QUAD2 320	330	331	332	332	358	358	0.000		
388-	QUAD2 321	331	332	333	333	359	359	0.000		
389-	QUAD2 322	332	333	334	334	360	360	0.000		
390-	QUAD2 323	333	334	335	335	361	361	0.000		
391-	QUAD2 324	334	335	336	336	362	362	0.000		
392-	QUAD2 325	335	336	337	337	363	363	0.000		
393-	QUAD2 326	336	337	338	338	364	364	0.000		
394-	QUAD2 327	337	338	339	339	365	365	0.000		
395-	QUAD2 328	338	339	340	340	366	366	0.000		
396-	QUAD2 329	339	340	341	341	367	367	0.000		
397-	QUAD2 330	340	341	342	342	368	368	0.000		
398-	QUAD2 331	341	342	343	343	369	369	0.000		
399-	QUAD2 332	342	343	344	344	370	370	0.000		
400-	QUAD2 333	343	344	345	345	371	371	0.000		
		344	345	346	346	372	372	0.000		
		345	346			373	373	0.000		

CARD	COUNT	1	2	3	4	5	6	7	8	9	10
401-	CQUAD2	334	346	347	347	347	374	374	0.000		
402-	CQUAD2	335	347	348	349	349	375	375	0.000		
403-	CQUAD2	336	348	349	350	350	376	376	0.000		
404-	CQUAD2	337	349	350	351	351	377	377	0.000		
405-	CQUAD2	338	350	351	352	352	378	378	0.000		
406-	CQUAD2	339	351	352	353	353	379	379	0.000		
407-	CQUAD2	340	352	353	354	354	380	380	0.000		
408-	CQUAD2	341	353	354	355	355	381	381	0.000		
409-	CQUAD2	342	354	355	356	356	382	382	0.000		
410-	CQUAD2	343	355	356	357	357	383	383	0.000		
411-	CQUAD2	344	356	357	358	358	384	384	0.000		
412-	CQUAD2	345	357	358	359	359	385	385	0.000		
413-	CQUAD2	346	358	359	360	360	386	386	0.000		
414-	CQUAD2	347	359	360	361	361	387	387	0.000		
415-	CQUAD2	348	360	361	362	362	388	388	0.000		
416-	CQUAD2	349	361	362	363	363	389	389	0.000		
417-	CQUAD2	350	362	363	364	364	390	390	0.000		
418-	CQUAD2	351	363	364	365	365	391	391	0.000		
419-	CQUAD2	352	364	365	366	366	392	392	0.000		
420-	CQUAD2	353	365	366	367	367	393	393	0.000		
421-	CQUAD2	354	366	367	368	368	394	394	0.000		
422-	CQUAD2	355	367	368	369	369	395	395	0.000		
423-	CQUAD2	356	368	369	370	370	396	396	0.000		
424-	CQUAD2	357	369	370	371	371	397	397	0.000		
425-	CQUAD2	358	370	371	372	372	398	398	0.000		
426-	CQUAD2	359	371	372	373	373	399	399	0.000		
427-	CQUAD2	360	372	373	374	374	400	400	0.000		
428-	CQUAD2	361	373	374	375	375	401	401	0.000		
429-	CQUAD2	362	374	375	376	376	402	402	0.000		
430-	CQUAD2	363	375	376	377	377	403	403	0.000		
431-	CQUAD2	364	376	377	378	378	404	404	0.000		
432-	CQUAD2	365	377	378	379	379	405	405	0.000		
433-	CQUAD2	366	378	379	380	380	406	406	0.000		
434-	CQUAD2	367	379	380	381	381	407	407	0.000		
435-	CQUAD2	368	380	381	382	382	408	408	0.000		
436-	CQUAD2	369	381	382	383	383	409	409	0.000		
437-	CQUAD2	370	382	383	384	384	410	410	0.000		
438-	CQUAD2	371	383	384	385	385	411	411	0.000		
439-	CQUAD2	372	384	385	386	386	412	412	0.000		
440-	CQUAD2	373	385	386	387	387	413	413	0.000		
441-	CQUAD2	374	386	387	388	388	414	414	0.000		
442-	CQUAD2	375	387	388	389	389	415	415	0.000		
443-	CQUAD2	376	388	389	390	390	416	416	0.000		
444-	CQUAD2	377	389	390	391	391	417	417	0.000		
445-	CQUAD2	378	390	391	392	392	418	418	0.000		
446-	CQUAD2	379	391	392	393	393	419	419	0.000		
447-	CQUAD2	380	392	393	394	394	420	420	0.000		
448-	CQUAD2	381	393	394	395	395	421	421	0.000		
449-	CQUAD2	382	394	395	396	396	422	422	0.000		
450-	CQUAD2	383	395	396	397	397	423	423	0.000		
			397	398	398	398	424	424	0.000		
			397	398	398	398	425	425	0.000		
			397	398	398	398	426	426	0.000		

CARD	1	2	3	4	5	6	7	8	9	10
451-	CQUA02 384	399	399	399	399	427	426	0.000	0.000	0.000
452-	CQUA02 385	399	399	399	400	428	427	0.000	0.000	0.000
453-	CQUA02 386	400	400	400	401	429	428	0.000	0.000	0.000
454-	CQUA02 387	401	401	401	402	430	429	0.000	0.000	0.000
455-	CQUA02 388	402	402	402	403	431	430	0.000	0.000	0.000
456-	CQUA02 389	403	403	403	404	432	431	0.000	0.000	0.000
457-	CQUA02 390	404	404	404	405	433	432	0.000	0.000	0.000
458-	CQUA02 391	405	405	405	406	434	433	0.000	0.000	0.000
459-	CQUA02 392	406	406	406	407	435	434	0.000	0.000	0.000
460-	CQUA02 393	407	407	407	408	436	435	0.000	0.000	0.000
461-	CQUA02 394	408	408	408	409	437	436	0.000	0.000	0.000
462-	CQUA02 395	409	409	409	410	438	437	0.000	0.000	0.000
463-	CQUA02 396	410	410	410	411	439	438	0.000	0.000	0.000
464-	CQUA02 397	411	411	411	412	440	439	0.000	0.000	0.000
465-	CQUA02 398	412	412	412	413	441	440	0.000	0.000	0.000
466-	CQUA02 399	413	413	413	414	442	441	0.000	0.000	0.000
467-	CQUA02 400	414	414	414	415	443	442	0.000	0.000	0.000
468-	CQUA02 401	415	415	415	416	444	443	0.000	0.000	0.000
469-	CQUA02 402	416	416	416	417	445	444	0.000	0.000	0.000
470-	CQUA02 403	417	417	417	418	446	445	0.000	0.000	0.000
471-	CQUA02 404	418	418	418	419	447	446	0.000	0.000	0.000
472-	CQUA02 405	419	419	419	420	448	447	0.000	0.000	0.000
473-	CQUA02 406	421	421	421	422	450	449	0.000	0.000	0.000
474-	CQUA02 407	422	422	422	423	451	450	0.000	0.000	0.000
475-	CQUA02 408	423	423	423	424	452	451	0.000	0.000	0.000
476-	CQUA02 409	424	424	424	425	453	452	0.000	0.000	0.000
477-	CQUA02 410	425	425	425	426	454	453	0.000	0.000	0.000
478-	CQUA02 411	426	426	426	427	455	454	0.000	0.000	0.000
479-	CQUA02 412	427	427	427	428	456	455	0.000	0.000	0.000
480-	CQUA02 413	428	428	428	429	457	456	0.000	0.000	0.000
481-	CQUA02 414	429	429	429	430	458	457	0.000	0.000	0.000
482-	CQUA02 415	430	430	430	431	459	458	0.000	0.000	0.000
483-	CQUA02 416	431	431	431	432	460	459	0.000	0.000	0.000
484-	CQUA02 417	432	432	432	433	461	460	0.000	0.000	0.000
485-	CQUA02 418	433	433	433	434	462	461	0.000	0.000	0.000
486-	CQUA02 419	434	434	434	435	463	462	0.000	0.000	0.000
487-	CQUA02 420	435	435	435	436	464	463	0.000	0.000	0.000
488-	CQUA02 421	436	436	436	437	465	464	0.000	0.000	0.000
489-	CQUA02 422	437	437	437	438	466	465	0.000	0.000	0.000
490-	CQUA02 423	438	438	438	439	467	466	0.000	0.000	0.000
491-	CQUA02 424	439	439	439	440	468	467	0.000	0.000	0.000
492-	CQUA02 425	440	440	440	441	469	468	0.000	0.000	0.000
493-	CQUA02 426	441	441	441	442	470	469	0.000	0.000	0.000
494-	CQUA02 427	442	442	442	443	471	470	0.000	0.000	0.000
495-	CQUA02 428	443	443	443	444	472	471	0.000	0.000	0.000
496-	CQUA02 429	444	444	444	445	473	472	0.000	0.000	0.000
497-	CQUA02 430	445	445	445	446	474	473	0.000	0.000	0.000
498-	CQUA02 431	446	446	446	447	475	474	0.000	0.000	0.000
499-	CQUA02 432	447	447	447	448	476	475	0.000	0.000	0.000
500-	GRAV *21					.0360000E+07				QGRAV1

CARD	COUNT	1	2	3	4	5	6	7	8	9	10
501-	*GRAV1	1	-1.0000	0.0000	.00	.00	.00	.00	.00	.00	.00
502-	GRID	2		.07	.00	.00	.00	.00	.00	.00	.00
503-	GRID	3		.15	.00	.00	.00	.00	.00	.00	.00
504-	GRID	4		.20	.00	.00	.00	.00	.00	.00	.00
505-	GRID	5		.30	.00	.00	.00	.00	.00	.00	.00
506-	GRID	6		.40	.00	.00	.00	.00	.00	.00	.00
507-	GRID	7		.65	.00	.00	.00	.00	.00	.00	.00
508-	GRID	8		.50	.00	.00	.00	.00	.00	.00	.00
509-	GRID	9		.55	.00	.00	.00	.00	.00	.00	.00
510-	GRID	10		.60	.00	.00	.00	.00	.00	.00	.00
511-	GRID	11		.65	.00	.00	.00	.00	.00	.00	.00
512-	GRID	12		.75	.00	.00	.00	.00	.00	.00	.00
513-	GRID	13		.85	.00	.00	.00	.00	.00	.00	.00
514-	GRID	14		.95	.00	.00	.00	.00	.00	.00	.00
515-	GRID	15		1.05	.00	.00	.00	.00	.00	.00	.00
516-	GRID	16		1.15	.00	.00	.00	.00	.00	.00	.00
517-	GRID	17		1.30	.00	.00	.00	.00	.00	.00	.00
518-	GRID	18		1.50	.00	.00	.00	.00	.00	.00	.00
519-	GRID	19		1.75	.00	.00	.00	.00	.00	.00	.00
520-	GRID	20		2.00	.00	.00	.00	.00	.00	.00	.00
521-	GRID	21		2.25	.00	.00	.00	.00	.00	.00	.00
522-	GRID	22		2.50	.00	.00	.00	.00	.00	.00	.00
523-	GRID	23		2.75	.00	.00	.00	.00	.00	.00	.00
524-	GRID	24		3.00	.00	.00	.00	.00	.00	.00	.00
525-	GRID	25		3.25	.00	.00	.00	.00	.00	.00	.00
526-	GRID	26		3.50	.00	.00	.00	.00	.00	.00	.00
527-	GRID	27		3.75	.00	.00	.00	.00	.00	.00	.00
528-	GRID	28		4.00	.00	.00	.00	.00	.00	.00	.00
529-	GRID	29		.00	.00	.00	.00	.00	.00	.00	.00
530-	GRID	30		.07	.17	.00	.00	.00	.00	.00	.00
531-	GRID	31		.15	.17	.00	.00	.00	.00	.00	.00
532-	GRID	32		.20	.17	.00	.00	.00	.00	.00	.00
533-	GRID	33		.30	.17	.00	.00	.00	.00	.00	.00
534-	GRID	34		.40	.17	.00	.00	.00	.00	.00	.00
535-	GRID	35		.45	.17	.00	.00	.00	.00	.00	.00
536-	GRID	36		.50	.17	.00	.00	.00	.00	.00	.00
537-	GRID	37		.55	.17	.00	.00	.00	.00	.00	.00
538-	GRID	38		.60	.17	.00	.00	.00	.00	.00	.00
539-	GRID	39		.65	.17	.00	.00	.00	.00	.00	.00
540-	GRID	40		.75	.17	.00	.00	.00	.00	.00	.00
541-	GRID	41		.85	.17	.00	.00	.00	.00	.00	.00
542-	GRID	42		.95	.17	.00	.00	.00	.00	.00	.00
543-	GRID	43		1.05	.17	.00	.00	.00	.00	.00	.00
544-	GRID	44		1.15	.17	.00	.00	.00	.00	.00	.00
545-	GRID	45		1.30	.17	.00	.00	.00	.00	.00	.00
546-	GRID	46		1.50	.17	.00	.00	.00	.00	.00	.00
547-	GRID	47		1.75	.17	.00	.00	.00	.00	.00	.00
548-	GRID	48		2.00	.17	.00	.00	.00	.00	.00	.00
549-	GRID	49		2.25	.17	.00	.00	.00	.00	.00	.00
550-	GRID	49		2.25	.17	.00	.00	.00	.00	.00	.00

S O R T E D B U L K D A T A E C H O

CARD	COUNT	1	2	3	4	5	6	7	8	9	10
551-	GRID 50	.00	2.50	.17	.00	.00	.00	.00	.00	.00	.00
552-	GRID 51	.00	2.75	.17	.00	.00	.00	.00	.00	.00	.00
553-	GRID 52	.00	3.00	.17	.00	.00	.00	.00	.00	.00	.00
554-	GRID 53	.00	3.25	.17	.00	.00	.00	.00	.00	.00	.00
555-	GRID 54	.00	3.50	.17	.00	.00	.00	.00	.00	.00	.00
556-	GRID 55	.00	3.75	.17	.00	.00	.00	.00	.00	.00	.00
557-	GRID 56	.00	4.00	.17	.00	.00	.00	.00	.00	.00	.00
558-	GRID 57	.00	.00	.20	.00	.00	.00	.00	.00	.00	.00
559-	GRID 58	.00	.07	.20	.00	.00	.00	.00	.00	.00	.00
560-	GRID 59	.00	.15	.20	.00	.00	.00	.00	.00	.00	.00
561-	GRID 60	.00	.20	.20	.00	.00	.00	.00	.00	.00	.00
562-	GRID 61	.00	.30	.20	.00	.00	.00	.00	.00	.00	.00
563-	GRID 62	.00	.40	.20	.00	.00	.00	.00	.00	.00	.00
564-	GRID 63	.00	.45	.20	.00	.00	.00	.00	.00	.00	.00
565-	GRID 64	.00	.50	.20	.00	.00	.00	.00	.00	.00	.00
566-	GRID 65	.00	.55	.20	.00	.00	.00	.00	.00	.00	.00
567-	GRID 66	.00	.60	.20	.00	.00	.00	.00	.00	.00	.00
568-	GRID 67	.00	.65	.20	.00	.00	.00	.00	.00	.00	.00
569-	GRID 68	.00	.75	.20	.00	.00	.00	.00	.00	.00	.00
570-	GRID 69	.00	.85	.20	.00	.00	.00	.00	.00	.00	.00
571-	GRID 70	.00	.95	.20	.00	.00	.00	.00	.00	.00	.00
572-	GRID 71	.00	1.05	.20	.00	.00	.00	.00	.00	.00	.00
573-	GRID 72	.00	1.15	.20	.00	.00	.00	.00	.00	.00	.00
574-	GRID 73	.00	1.30	.20	.00	.00	.00	.00	.00	.00	.00
575-	GRID 74	.00	1.50	.20	.00	.00	.00	.00	.00	.00	.00
576-	GRID 75	.00	1.75	.20	.00	.00	.00	.00	.00	.00	.00
577-	GRID 76	.00	2.00	.20	.00	.00	.00	.00	.00	.00	.00
578-	GRID 77	.00	2.25	.20	.00	.00	.00	.00	.00	.00	.00
579-	GRID 78	.00	2.50	.20	.00	.00	.00	.00	.00	.00	.00
580-	GRID 79	.00	2.75	.20	.00	.00	.00	.00	.00	.00	.00
581-	GRID 80	.00	3.00	.20	.00	.00	.00	.00	.00	.00	.00
582-	GRID 81	.00	3.25	.20	.00	.00	.00	.00	.00	.00	.00
583-	GRID 82	.00	3.50	.20	.00	.00	.00	.00	.00	.00	.00
584-	GRID 83	.00	3.75	.20	.00	.00	.00	.00	.00	.00	.00
585-	GRID 84	.00	4.00	.20	.00	.00	.00	.00	.00	.00	.00
586-	GRID 85	.00	.00	.40	.00	.00	.00	.00	.00	.00	.00
587-	GRID 86	.00	.07	.40	.00	.00	.00	.00	.00	.00	.00
588-	GRID 87	.00	.15	.40	.00	.00	.00	.00	.00	.00	.00
589-	GRID 88	.00	.20	.40	.00	.00	.00	.00	.00	.00	.00
590-	GRID 89	.00	.30	.40	.00	.00	.00	.00	.00	.00	.00
591-	GRID 90	.00	.40	.40	.00	.00	.00	.00	.00	.00	.00
592-	GRID 91	.00	.45	.40	.00	.00	.00	.00	.00	.00	.00
593-	GRID 92	.00	.50	.40	.00	.00	.00	.00	.00	.00	.00
594-	GRID 93	.00	.55	.40	.00	.00	.00	.00	.00	.00	.00
595-	GRID 94	.00	.60	.40	.00	.00	.00	.00	.00	.00	.00
596-	GRID 95	.00	.65	.40	.00	.00	.00	.00	.00	.00	.00
597-	GRID 96	.00	.75	.40	.00	.00	.00	.00	.00	.00	.00
598-	GRID 97	.00	.85	.40	.00	.00	.00	.00	.00	.00	.00
599-	GRID 98	.00	.95	.40	.00	.00	.00	.00	.00	.00	.00
600-	GRID 99	.00	1.05	.40	.00	.00	.00	.00	.00	.00	.00

CARD	1	2	3	4	5	6	7	8	9	10
COUNT										
601-	GRID 100			1.15	.40	.00				
602-	GRID 101			1.30	.40	.00				
603-	GRID 102			1.50	.40	.00				
604-	GRID 103			1.75	.40	.00				
605-	GRID 104			2.00	.40	.00				
606-	GRID 105			2.25	.40	.00				
607-	GRID 106			2.50	.40	.00				
608-	GRID 107			2.75	.40	.00				
609-	GRID 108			3.00	.40	.00				
610-	GRID 109			3.25	.40	.00				
611-	GRID 110			3.50	.40	.00				
612-	GRID 111			3.75	.40	.00				
613-	GRID 112			4.00	.40	.00				
614-	GRID 113			.00	.60	.00				
615-	GRID 114			.07	.60	.00				
616-	GRID 115			.15	.60	.00				
617-	GRID 116			.20	.60	.00				
618-	GRID 117			.30	.60	.00				
619-	GRID 118			.40	.60	.00				
620-	GRID 119			.45	.60	.00				
621-	GRID 120			.50	.60	.00				
622-	GRID 121			.55	.60	.00				
623-	GRID 122			.60	.60	.00				
624-	GRID 123			.65	.60	.00				
625-	GRID 124			.75	.60	.00				
626-	GRID 125			.85	.60	.00				
627-	GRID 126			.95	.60	.00				
628-	GRID 127			1.05	.60	.00				
629-	GRID 128			1.15	.60	.00				
630-	GRID 129			1.30	.60	.00				
631-	GRID 130			1.50	.60	.00				
632-	GRID 131			1.75	.60	.00				
633-	GRID 132			2.00	.60	.00				
634-	GRID 133			2.25	.60	.00				
635-	GRID 134			2.50	.60	.00				
636-	GRID 135			2.75	.60	.00				
637-	GRID 136			3.00	.60	.00				
638-	GRID 137			3.25	.60	.00				
639-	GRID 138			3.50	.60	.00				
640-	GRID 139			3.75	.60	.00				
641-	GRID 140			4.00	.60	.00				
642-	GRID 141			.00	.80	.00				
643-	GRID 142			.07	.80	.00				
644-	GRID 143			.15	.80	.00				
645-	GRID 144			.20	.80	.00				
646-	GRID 145			.30	.80	.00				
647-	GRID 146			.40	.80	.00				
648-	GRID 147			.45	.80	.00				
649-	GRID 148			.50	.80	.00				
650-	GRID 149			.55	.80	.00				

S O R T E D B U L K D A T A E C H O

CARD COUNT	1	2	3	4	5	6	7	8	9	10
GRID 150	.60	.60	.60	.60	.60	.60	.60	.60	.60	.60
GRID 151	.65	.65	.65	.65	.65	.65	.65	.65	.65	.65
GRID 152	.75	.75	.75	.75	.75	.75	.75	.75	.75	.75
GRID 153	.85	.85	.85	.85	.85	.85	.85	.85	.85	.85
GRID 154	.95	.95	.95	.95	.95	.95	.95	.95	.95	.95
GRID 155	1.05	1.05	1.05	1.05	1.05	1.05	1.05	1.05	1.05	1.05
GRID 156	1.15	1.15	1.15	1.15	1.15	1.15	1.15	1.15	1.15	1.15
GRID 157	1.30	1.30	1.30	1.30	1.30	1.30	1.30	1.30	1.30	1.30
GRID 158	1.50	1.50	1.50	1.50	1.50	1.50	1.50	1.50	1.50	1.50
GRID 159	1.75	1.75	1.75	1.75	1.75	1.75	1.75	1.75	1.75	1.75
GRID 160	2.00	2.00	2.00	2.00	2.00	2.00	2.00	2.00	2.00	2.00
GRID 161	2.25	2.25	2.25	2.25	2.25	2.25	2.25	2.25	2.25	2.25
GRID 162	2.50	2.50	2.50	2.50	2.50	2.50	2.50	2.50	2.50	2.50
GRID 163	2.75	2.75	2.75	2.75	2.75	2.75	2.75	2.75	2.75	2.75
GRID 164	3.00	3.00	3.00	3.00	3.00	3.00	3.00	3.00	3.00	3.00
GRID 165	3.25	3.25	3.25	3.25	3.25	3.25	3.25	3.25	3.25	3.25
GRID 166	3.50	3.50	3.50	3.50	3.50	3.50	3.50	3.50	3.50	3.50
GRID 167	3.75	3.75	3.75	3.75	3.75	3.75	3.75	3.75	3.75	3.75
GRID 168	4.00	4.00	4.00	4.00	4.00	4.00	4.00	4.00	4.00	4.00
GRID 169	.00	.00	.00	.00	.00	.00	.00	.00	.00	.00
GRID 170	.07	.07	.07	.07	.07	.07	.07	.07	.07	.07
GRID 171	.15	.15	.15	.15	.15	.15	.15	.15	.15	.15
GRID 172	.20	.20	.20	.20	.20	.20	.20	.20	.20	.20
GRID 173	.30	.30	.30	.30	.30	.30	.30	.30	.30	.30
GRID 174	.40	.40	.40	.40	.40	.40	.40	.40	.40	.40
GRID 175	.45	.45	.45	.45	.45	.45	.45	.45	.45	.45
GRID 176	.50	.50	.50	.50	.50	.50	.50	.50	.50	.50
GRID 177	.55	.55	.55	.55	.55	.55	.55	.55	.55	.55
GRID 178	.60	.60	.60	.60	.60	.60	.60	.60	.60	.60
GRID 179	.65	.65	.65	.65	.65	.65	.65	.65	.65	.65
GRID 180	.75	.75	.75	.75	.75	.75	.75	.75	.75	.75
GRID 181	.85	.85	.85	.85	.85	.85	.85	.85	.85	.85
GRID 182	.95	.95	.95	.95	.95	.95	.95	.95	.95	.95
GRID 183	1.05	1.05	1.05	1.05	1.05	1.05	1.05	1.05	1.05	1.05
GRID 184	1.15	1.15	1.15	1.15	1.15	1.15	1.15	1.15	1.15	1.15
GRID 185	1.30	1.30	1.30	1.30	1.30	1.30	1.30	1.30	1.30	1.30
GRID 186	1.50	1.50	1.50	1.50	1.50	1.50	1.50	1.50	1.50	1.50
GRID 187	1.75	1.75	1.75	1.75	1.75	1.75	1.75	1.75	1.75	1.75
GRID 188	2.00	2.00	2.00	2.00	2.00	2.00	2.00	2.00	2.00	2.00
GRID 189	2.25	2.25	2.25	2.25	2.25	2.25	2.25	2.25	2.25	2.25
GRID 190	2.50	2.50	2.50	2.50	2.50	2.50	2.50	2.50	2.50	2.50
GRID 191	2.75	2.75	2.75	2.75	2.75	2.75	2.75	2.75	2.75	2.75
GRID 192	3.00	3.00	3.00	3.00	3.00	3.00	3.00	3.00	3.00	3.00
GRID 193	3.25	3.25	3.25	3.25	3.25	3.25	3.25	3.25	3.25	3.25
GRID 194	3.50	3.50	3.50	3.50	3.50	3.50	3.50	3.50	3.50	3.50
GRID 195	3.75	3.75	3.75	3.75	3.75	3.75	3.75	3.75	3.75	3.75
GRID 196	4.00	4.00	4.00	4.00	4.00	4.00	4.00	4.00	4.00	4.00
GRID 197	.00	.00	.00	.00	.00	.00	.00	.00	.00	.00
GRID 198	.07	.07	.07	.07	.07	.07	.07	.07	.07	.07
GRID 199	.15	.15	.15	.15	.15	.15	.15	.15	.15	.15
GRID 200	.00	.00	.00	.00	.00	.00	.00	.00	.00	.00

SORTED BULK DATA ECHO

CARD COUNT	1	2	3	4	5	6	7	8	9	10
701-	GRID 200	.20	1.20	.00						
702-	GRID 201	.30	1.20	.00						
703-	GRID 202	.40	1.20	.00						
704-	GRID 203	.45	1.20	.00						
705-	GRID 204	.50	1.20	.00						
706-	GRID 205	.55	1.20	.00						
707-	GRID 206	.60	1.20	.00						
708-	GRID 207	.65	1.20	.00						
709-	GRID 208	.75	1.20	.00						
710-	GRID 209	.85	1.20	.00						
711-	GRID 210	.95	1.20	.00						
712-	GRID 211	1.05	1.20	.00						
713-	GRID 212	1.15	1.20	.00						
714-	GRID 213	1.30	1.20	.00						
715-	GRID 214	1.50	1.20	.00						
716-	GRID 215	1.75	1.20	.00						
717-	GRID 216	2.00	1.20	.00						
718-	GRID 217	2.25	1.20	.00						
719-	GRID 218	2.50	1.20	.00						
720-	GRID 219	2.75	1.20	.00						
721-	GRID 220	3.00	1.20	.00						
722-	GRID 221	3.25	1.20	.00						
723-	GRID 222	3.50	1.20	.00						
724-	GRID 223	3.75	1.20	.00						
725-	GRID 224	4.00	1.20	.00						
726-	GRID 225	.00	1.40	.00						
727-	GRID 226	.07	1.40	.00						
728-	GRID 227	.15	1.40	.00						
729-	GRID 228	.20	1.40	.00						
730-	GRID 229	.30	1.40	.00						
731-	GRID 230	.40	1.40	.00						
732-	GRID 231	.45	1.40	.00						
733-	GRID 232	.50	1.40	.00						
734-	GRID 233	.55	1.40	.00						
735-	GRID 234	.60	1.40	.00						
736-	GRID 235	.65	1.40	.00						
737-	GRID 236	.75	1.40	.00						
738-	GRID 237	.85	1.40	.00						
739-	GRID 238	.95	1.40	.00						
740-	GRID 239	1.05	1.40	.00						
741-	GRID 240	1.15	1.40	.00						
742-	GRID 241	1.30	1.40	.00						
743-	GRID 242	1.50	1.40	.00						
744-	GRID 243	1.75	1.40	.00						
745-	GRID 244	2.00	1.40	.00						
746-	GRID 245	2.25	1.40	.00						
747-	GRID 246	2.50	1.40	.00						
748-	GRID 247	2.75	1.40	.00						
749-	GRID 248	3.00	1.40	.00						
750-	GRID 249	3.25	1.40	.00						

CARD	COUNT	1	2	3	4	5	6	7	8	9	10
751-	GRID	250	3.50	1.40	.00						
752-	GRID	251	3.75	1.40	.00						
753-	GRID	252	4.00	1.40	.00						
754-	GRID	253	.00	1.60	.00						
755-	GRID	254	.07	1.60	.00						
756-	GRID	255	.15	1.60	.00						
757-	GRID	256	.20	1.60	.00						
758-	GRID	257	.30	1.60	.00						
759-	GRID	258	.40	1.60	.00						
760-	GRID	259	.45	1.60	.00						
761-	GRID	260	.50	1.60	.00						
762-	GRID	261	.55	1.60	.00						
763-	GRID	262	.60	1.60	.00						
764-	GRID	263	.65	1.60	.00						
765-	GRID	264	.75	1.60	.00						
766-	GRID	265	.85	1.60	.00						
767-	GRID	266	.95	1.60	.00						
768-	GRID	267	1.05	1.60	.00						
769-	GRID	268	1.15	1.60	.00						
770-	GRID	269	1.30	1.60	.00						
771-	GRID	270	1.50	1.60	.00						
772-	GRID	271	1.75	1.60	.00						
773-	GRID	272	2.00	1.60	.00						
774-	GRID	273	2.25	1.60	.00						
775-	GRID	274	2.50	1.60	.00						
776-	GRID	275	2.75	1.60	.00						
777-	GRID	276	3.00	1.60	.00						
778-	GRID	277	3.25	1.60	.00						
779-	GRID	278	3.50	1.60	.00						
780-	GRID	279	3.75	1.60	.00						
781-	GRID	280	4.00	1.60	.00						
782-	GRID	281	.00	1.80	.00						
783-	GRID	282	.07	1.80	.00						
784-	GRID	283	.15	1.80	.00						
785-	GRID	284	.20	1.80	.00						
786-	GRID	295	.30	1.80	.00						
787-	GRID	286	.40	1.80	.00						
788-	GRID	297	.45	1.80	.00						
789-	GRID	298	.50	1.80	.00						
790-	GRID	289	.55	1.80	.00						
791-	GRID	290	.60	1.80	.00						
792-	GRID	291	.65	1.80	.00						
793-	GRID	292	.75	1.80	.00						
794-	GRID	293	.85	1.80	.00						
795-	GRID	234	.95	1.80	.00						
796-	GRID	295	1.05	1.80	.00						
797-	GRID	296	1.15	1.80	.00						
798-	GRID	297	1.30	1.80	.00						
799-	GRID	298	1.50	1.80	.00						
800-	GRID	299	1.75	1.80	.00						

S O R T E D B U L K D A T A E C H O

CARD	1	2	3	4	5	6	7	8	9	10
COUNT	300	301	302	303	304	305	306	307	308	309
801-	GRID	GRID	GRID	GRID	GRID	GRID	GRID	GRID	GRID	GRID
802-	GRID	GRID	GRID	GRID	GRID	GRID	GRID	GRID	GRID	GRID
803-	GRID	GRID	GRID	GRID	GRID	GRID	GRID	GRID	GRID	GRID
804-	GRID	GRID	GRID	GRID	GRID	GRID	GRID	GRID	GRID	GRID
805-	GRID	GRID	GRID	GRID	GRID	GRID	GRID	GRID	GRID	GRID
806-	GRID	GRID	GRID	GRID	GRID	GRID	GRID	GRID	GRID	GRID
807-	GRID	GRID	GRID	GRID	GRID	GRID	GRID	GRID	GRID	GRID
808-	GRID	GRID	GRID	GRID	GRID	GRID	GRID	GRID	GRID	GRID
809-	GRID	GRID	GRID	GRID	GRID	GRID	GRID	GRID	GRID	GRID
810-	GRID	GRID	GRID	GRID	GRID	GRID	GRID	GRID	GRID	GRID
811-	GRID	GRID	GRID	GRID	GRID	GRID	GRID	GRID	GRID	GRID
812-	GRID	GRID	GRID	GRID	GRID	GRID	GRID	GRID	GRID	GRID
813-	GRID	GRID	GRID	GRID	GRID	GRID	GRID	GRID	GRID	GRID
814-	GRID	GRID	GRID	GRID	GRID	GRID	GRID	GRID	GRID	GRID
815-	GRID	GRID	GRID	GRID	GRID	GRID	GRID	GRID	GRID	GRID
816-	GRID	GRID	GRID	GRID	GRID	GRID	GRID	GRID	GRID	GRID
817-	GRID	GRID	GRID	GRID	GRID	GRID	GRID	GRID	GRID	GRID
818-	GRID	GRID	GRID	GRID	GRID	GRID	GRID	GRID	GRID	GRID
819-	GRID	GRID	GRID	GRID	GRID	GRID	GRID	GRID	GRID	GRID
820-	GRID	GRID	GRID	GRID	GRID	GRID	GRID	GRID	GRID	GRID
821-	GRID	GRID	GRID	GRID	GRID	GRID	GRID	GRID	GRID	GRID
822-	GRID	GRID	GRID	GRID	GRID	GRID	GRID	GRID	GRID	GRID
823-	GRID	GRID	GRID	GRID	GRID	GRID	GRID	GRID	GRID	GRID
824-	GRID	GRID	GRID	GRID	GRID	GRID	GRID	GRID	GRID	GRID
825-	GRID	GRID	GRID	GRID	GRID	GRID	GRID	GRID	GRID	GRID
826-	GRID	GRID	GRID	GRID	GRID	GRID	GRID	GRID	GRID	GRID
827-	GRID	GRID	GRID	GRID	GRID	GRID	GRID	GRID	GRID	GRID
828-	GRID	GRID	GRID	GRID	GRID	GRID	GRID	GRID	GRID	GRID
829-	GRID	GRID	GRID	GRID	GRID	GRID	GRID	GRID	GRID	GRID
830-	GRID	GRID	GRID	GRID	GRID	GRID	GRID	GRID	GRID	GRID
831-	GRID	GRID	GRID	GRID	GRID	GRID	GRID	GRID	GRID	GRID
832-	GRID	GRID	GRID	GRID	GRID	GRID	GRID	GRID	GRID	GRID
833-	GRID	GRID	GRID	GRID	GRID	GRID	GRID	GRID	GRID	GRID
834-	GRID	GRID	GRID	GRID	GRID	GRID	GRID	GRID	GRID	GRID
835-	GRID	GRID	GRID	GRID	GRID	GRID	GRID	GRID	GRID	GRID
836-	GRID	GRID	GRID	GRID	GRID	GRID	GRID	GRID	GRID	GRID
837-	GRID	GRID	GRID	GRID	GRID	GRID	GRID	GRID	GRID	GRID
838-	GRID	GRID	GRID	GRID	GRID	GRID	GRID	GRID	GRID	GRID
839-	GRID	GRID	GRID	GRID	GRID	GRID	GRID	GRID	GRID	GRID
840-	GRID	GRID	GRID	GRID	GRID	GRID	GRID	GRID	GRID	GRID
841-	GRID	GRID	GRID	GRID	GRID	GRID	GRID	GRID	GRID	GRID
842-	GRID	GRID	GRID	GRID	GRID	GRID	GRID	GRID	GRID	GRID
843-	GRID	GRID	GRID	GRID	GRID	GRID	GRID	GRID	GRID	GRID
844-	GRID	GRID	GRID	GRID	GRID	GRID	GRID	GRID	GRID	GRID
845-	GRID	GRID	GRID	GRID	GRID	GRID	GRID	GRID	GRID	GRID
846-	GRID	GRID	GRID	GRID	GRID	GRID	GRID	GRID	GRID	GRID
847-	GRID	GRID	GRID	GRID	GRID	GRID	GRID	GRID	GRID	GRID
848-	GRID	GRID	GRID	GRID	GRID	GRID	GRID	GRID	GRID	GRID
849-	GRID	GRID	GRID	GRID	GRID	GRID	GRID	GRID	GRID	GRID
850-	GRID	GRID	GRID	GRID	GRID	GRID	GRID	GRID	GRID	GRID

SORTED BULK DATA ECHO

CARD	1	2	3	4	5	6	7	8	9	10
851-	GRID	350	..95	2.20	..00					
852-	GRID	351	1.05	2.20	..00					
853-	GRID	352	1.15	2.20	..00					
854-	GRID	353	1.30	2.20	..00					
855-	GRID	354	1.50	2.20	..00					
856-	GRID	355	1.75	2.20	..00					
857-	GRID	356	2.00	2.20	..00					
858-	GRID	357	2.25	2.20	..00					
859-	GRID	358	2.50	2.20	..00					
860-	GRID	359	2.75	2.20	..00					
861-	GRID	360	3.00	2.20	..00					
862-	GRID	361	3.25	2.20	..00					
863-	GRID	362	3.50	2.20	..00					
864-	GRID	363	3.75	2.20	..00					
865-	GRID	364	4.00	2.20	..00					
866-	GRID	365	..00	2.40	..00					
867-	GRID	366	.07	2.40	..00					
868-	GRID	367	.15	2.40	..00					
869-	GRID	368	.20	2.40	..00					
870-	GRID	369	.30	2.40	..00					
871-	GRID	370	.40	2.40	..00					
872-	GRID	371	.45	2.40	..00					
873-	GRID	372	.50	2.40	..00					
874-	GRID	373	.55	2.40	..00					
875-	GRID	374	.60	2.40	..00					
876-	GRID	375	.65	2.40	..00					
877-	GRID	376	.75	2.40	..00					
878-	GRID	377	.85	2.40	..00					
879-	GRID	378	.95	2.40	..00					
880-	GRID	379	1.05	2.40	..00					
881-	GRID	380	1.15	2.40	..00					
882-	GRID	381	1.30	2.40	..00					
883-	GRID	382	1.50	2.40	..00					
884-	GRID	383	1.75	2.40	..00					
885-	GRID	384	2.00	2.40	..00					
886-	GRID	385	2.25	2.40	..00					
887-	GRID	386	2.50	2.40	..00					
888-	GRID	387	2.75	2.40	..00					
889-	GRID	388	3.00	2.40	..00					
890-	GRID	389	3.25	2.40	..00					
891-	GRID	390	3.50	2.40	..00					
892-	GRID	391	3.75	2.40	..00					
893-	GRID	392	4.00	2.40	..00					
894-	GRID	393	..00	2.60	..00					
895-	GRID	394	.07	2.60	..00					
896-	GRID	395	.15	2.60	..00					
897-	GRID	396	.20	2.60	..00					
898-	GRID	397	.30	2.60	..00					
899-	GRID	398	.40	2.60	..00					
900-	GRID	399	.45	2.60	..00					

CARD	COUNT	1	2	3	4	5	6	7	8	9	10
901-	GRID	400	.50	2.60	.00	.00	.00	.00	.00	.00	.00
902-	GRID	401	.55	2.60	.00	.00	.00	.00	.00	.00	.00
903-	GRID	402	.60	2.60	.00	.00	.00	.00	.00	.00	.00
904-	GRID	403	.65	2.60	.00	.00	.00	.00	.00	.00	.00
905-	GRID	404	.75	2.60	.00	.00	.00	.00	.00	.00	.00
906-	GRID	405	.85	2.60	.00	.00	.00	.00	.00	.00	.00
907-	GRID	406	.95	2.60	.00	.00	.00	.00	.00	.00	.00
908-	GRID	407	1.05	2.60	.00	.00	.00	.00	.00	.00	.00
909-	GRID	408	1.15	2.60	.00	.00	.00	.00	.00	.00	.00
910-	GRID	409	1.30	2.60	.00	.00	.00	.00	.00	.00	.00
911-	GRID	410	1.50	2.60	.00	.00	.00	.00	.00	.00	.00
912-	GRID	411	1.75	2.60	.00	.00	.00	.00	.00	.00	.00
913-	GRID	412	2.00	2.60	.00	.00	.00	.00	.00	.00	.00
914-	GRID	413	2.25	2.60	.00	.00	.00	.00	.00	.00	.00
915-	GRID	414	2.50	2.60	.00	.00	.00	.00	.00	.00	.00
916-	GRID	415	2.75	2.60	.00	.00	.00	.00	.00	.00	.00
917-	GRID	416	3.00	2.60	.00	.00	.00	.00	.00	.00	.00
918-	GRID	417	3.25	2.60	.00	.00	.00	.00	.00	.00	.00
919-	GRID	418	3.50	2.60	.00	.00	.00	.00	.00	.00	.00
920-	GRID	419	3.75	2.60	.00	.00	.00	.00	.00	.00	.00
921-	GRID	420	4.00	2.60	.00	.00	.00	.00	.00	.00	.00
922-	GRID	421	.00	2.70	.00	.00	.00	.00	.00	.00	.00
923-	GRID	422	.07	2.70	.00	.00	.00	.00	.00	.00	.00
924-	GRID	423	.15	2.70	.00	.00	.00	.00	.00	.00	.00
925-	GRID	424	.20	2.70	.00	.00	.00	.00	.00	.00	.00
926-	GRID	425	.30	2.70	.00	.00	.00	.00	.00	.00	.00
927-	GRID	426	.40	2.70	.00	.00	.00	.00	.00	.00	.00
928-	GRID	427	.45	2.70	.00	.00	.00	.00	.00	.00	.00
929-	GRID	428	.50	2.70	.00	.00	.00	.00	.00	.00	.00
930-	GRID	429	.55	2.70	.00	.00	.00	.00	.00	.00	.00
931-	GRID	430	.60	2.70	.00	.00	.00	.00	.00	.00	.00
932-	GRID	431	.65	2.70	.00	.00	.00	.00	.00	.00	.00
933-	GRID	432	.75	2.70	.00	.00	.00	.00	.00	.00	.00
934-	GRID	433	.85	2.70	.00	.00	.00	.00	.00	.00	.00
935-	GRID	434	.95	2.70	.00	.00	.00	.00	.00	.00	.00
936-	GRID	435	1.05	2.70	.00	.00	.00	.00	.00	.00	.00
937-	GRID	436	1.15	2.70	.00	.00	.00	.00	.00	.00	.00
938-	GRID	437	1.30	2.70	.00	.00	.00	.00	.00	.00	.00
939-	GRID	438	1.50	2.70	.00	.00	.00	.00	.00	.00	.00
940-	GRID	439	1.75	2.70	.00	.00	.00	.00	.00	.00	.00
941-	GRID	440	2.00	2.70	.00	.00	.00	.00	.00	.00	.00
942-	GRID	441	2.25	2.70	.00	.00	.00	.00	.00	.00	.00
943-	GRID	442	2.50	2.70	.00	.00	.00	.00	.00	.00	.00
944-	GRID	443	2.75	2.70	.00	.00	.00	.00	.00	.00	.00
945-	GRID	444	3.00	2.70	.00	.00	.00	.00	.00	.00	.00
946-	GRID	445	3.25	2.70	.00	.00	.00	.00	.00	.00	.00
947-	GRID	446	3.50	2.70	.00	.00	.00	.00	.00	.00	.00
948-	GRID	447	3.75	2.70	.00	.00	.00	.00	.00	.00	.00
949-	GRID	448	4.00	2.70	.00	.00	.00	.00	.00	.00	.00
950-	GRID	449	.00	2.83	.00	.00	.00	.00	.00	.00	.00

SORTED PULK DATA ECHO

CARD COUNT	1	2	3	4	5	6	7	8	9	10
951-	GRID 450	.07	2.83	.00	.00	.00	.00	.00	.00	.00
952-	GRID 451	.15	2.83	.00	.00	.00	.00	.00	.00	.00
953-	GRID 452	.20	2.83	.00	.00	.00	.00	.00	.00	.00
954-	GRID 453	.30	2.83	.00	.00	.00	.00	.00	.00	.00
955-	GRID 454	.40	2.83	.00	.00	.00	.00	.00	.00	.00
956-	GRID 455	.45	2.83	.00	.00	.00	.00	.00	.00	.00
957-	GRID 456	.50	2.83	.00	.00	.00	.00	.00	.00	.00
958-	GRID 457	.55	2.83	.00	.00	.00	.00	.00	.00	.00
959-	GRID 458	.60	2.83	.00	.00	.00	.00	.00	.00	.00
960-	GRID 459	.65	2.83	.00	.00	.00	.00	.00	.00	.00
961-	GRID 460	.75	2.83	.00	.00	.00	.00	.00	.00	.00
962-	GRID 461	.85	2.83	.00	.00	.00	.00	.00	.00	.00
963-	GRID 462	.95	2.83	.00	.00	.00	.00	.00	.00	.00
964-	GRID 463	1.05	2.83	.00	.00	.00	.00	.00	.00	.00
965-	GRID 464	1.15	2.83	.00	.00	.00	.00	.00	.00	.00
966-	GRID 465	1.30	2.83	.00	.00	.00	.00	.00	.00	.00
967-	GRID 466	1.50	2.83	.00	.00	.00	.00	.00	.00	.00
968-	GRID 467	1.75	2.83	.00	.00	.00	.00	.00	.00	.00
969-	GRID 468	2.00	2.83	.00	.00	.00	.00	.00	.00	.00
970-	GRID 469	2.25	2.83	.00	.00	.00	.00	.00	.00	.00
971-	GRID 470	2.50	2.83	.00	.00	.00	.00	.00	.00	.00
972-	GRID 471	2.75	2.83	.00	.00	.00	.00	.00	.00	.00
973-	GRID 472	3.00	2.83	.00	.00	.00	.00	.00	.00	.00
974-	GRID 473	3.25	2.83	.00	.00	.00	.00	.00	.00	.00
975-	GRID 474	3.50	2.83	.00	.00	.00	.00	.00	.00	.00
976-	GRID 475	3.75	2.83	.00	.00	.00	.00	.00	.00	.00
977-	GRID 476	4.00	2.83	.00	.00	.00	.00	.00	.00	.00
978-	GRID 477	4.25	2.83	.00	.00	.00	.00	.00	.00	.00
979-	GRID 478	4.50	2.83	.00	.00	.00	.00	.00	.00	.00
980-	GRID 479	4.75	2.83	.00	.00	.00	.00	.00	.00	.00
981-	GRID 480	5.00	2.83	.00	.00	.00	.00	.00	.00	.00
982-	GRID 481	5.25	2.83	.00	.00	.00	.00	.00	.00	.00
983-	GRID 482	5.50	2.83	.00	.00	.00	.00	.00	.00	.00
984-	LOAD 30	1.0000	1.0000	20	1.0000	21				
985-	MAT1 5	3.0E7	.3200	.3200	.2800					
986-	MAT1 6	3.0E7	.3200	.3200	.2800					
987-	MAT1 7	3.0E0	.3200	.3200	.0001					
988-	MAT1 8	3.0E0	.3200	.3200	.0001					
989-	MAT2 1	12.98+6	1.97+6		6.53+6		2.27+6	.056		
990-	MAT2 2	12.98+6	1.97+6		6.53+6		2.27+6	.056		
991-	MAT2 3	12.98+6	1.97+6		6.53+6		2.27+6	.056		
992-	MAT2 4	12.98+6	1.97+6		6.53+6		2.27+6	.056		
993-	PARAM	GROUP 0								
994-	PARAM	WIMASS	.002588							
995-	PARAM	*5				.25+3637E+00			QABCODEF1	
996-	PARAM	*ARCODEF1	.1245837E-01	.24000						
997-	PARAM	*6				.3141593E-01			QABCODEF2	
998-	PARAM	*ABCODEF2	.7853982E-04	.200000E+00						
999-	PARAM	*7	.1582665E-04	.1250000E+00					QABCODEF3	
1000-	PARAM	*ARCODEF3	.1582665E-04	.1250000E+00						

S O R T E D B U L K D A T A E C H O

CARD COUNT	1	2	3	4	5	6	7	8	9	10
1001-	PBAR	3								
1002-	*ABCODEF4	.3998198E-05		.9500000E-01		.7088218E-02		.3998198E-05		0ABCODEF4
1003-	PBAR	3		.4415		.0155		.80000		
1004-	PQUAD2 1	1		.2240						
1005-	PQUAD2 2	2		.2240						
1006-	PQUAD2 3	3		.2240						
1007-	PQUAD2 4	4		.224						
1008-	RFORCE *20	482								
1009-	*RFORCE1	1.0000	0.0000	0.0000						
1010-	SPC1 100	15								
1011-	SPC1 101	15	28							
1012-	SPC1 102	15	56							
1013-	SPC1 103	15	84							
1014-	SPC1 104	15	112							
1015-	SPC1 105	15	140							
1016-	SPC1 106	15	168							
1017-	SPC1 107	15	196							
1018-	SPC1 108	15	224							
1019-	SPC1 109	15	252							
1020-	SPC1 110	15	280							
1021-	SPC1 111	15	308							
1022-	SPC1 112	15	336							
1023-	SPC1 113	15	364							
1024-	SPC1 114	15	392							
1025-	SPC1 115	15	420							
1026-	SPC1 116	15	448							
1027-	SPC1 500	123456	477							
1028-	SPC1 501	6	1	432						
1029-	SPC1 501	6	57	THRU 28						
1030-	SPC1 501	6	226	THRU 224						
1031-	SPC1 501	6	254	THRU 252						
1032-	SPC1 501	6	282	THRU 280						
1033-	SPC1 501	6	310	THRU 308						
1034-	SPC1 501	6	338	THRU 336						
1035-	SPC1 501	6	366	THRU 364						
1036-	SPC1 501	6	394	THRU 392						
1037-	SPC1 502	2	479	THRU 476						
1038-	SPC1 503	2	478	479						
1039-	SPC1 504	2	478	479						
1040-	SPC1 505	2	478	480						
1041-	SPC1 506	2	478	479						
1042-	*BC20	30	100	479						
1043-	*BC21	107	108	109	481					
1044-	*BC30	115	116	117	103	104				
1045-	*BC31	107	108	109	110	111	105	106		ABC20
1046-	SPCA00 91	115	116	500	501	502	112	113	106	114ABC21
1047-	*BC40	107	108	109	103	104	105	106		ABC30
1048-	*BC41	115	116	500	501	503	112	113	106	114ABC31
1049-	SPCA00 92	107	108	109	103	104	105	106		ABC40
1050-	SPCA00 93	115	116	500	501	504	112	113	106	114ABC41
		100	101	102	103	104	105	106		ABC50

K.F.SCHWARTZ, 60% SIZE #70 (0 DEG.=3,+45,-45,90 DEG. LAYERS) AS DECEMBER 22, 1976 NASTRAN 9/16/74 PAGE 24

CARD COUNT	1	2	3	4	5	6	7	8	9	10
1051-	..	107	108	109	110	111	112	113	114	ABC51
1052-	94	115	116	500	501	505				
1053-		107	109	101	102	103	104	105	106	ABC60
1054-		115	116	500	501	506				
1055-	99	107	108	109	102	103	104	105	106	ABC10
1056-		115	116	500	501	504				
1057-										
1058-										

SORTED BULK DATA ECHO

NO ERRORS FOUND - EXECUTE NASTRAN PROGRAM

APPENDIX D

VANE DEFLECTED SHAPES FOR 22 ANALYSIS CASES

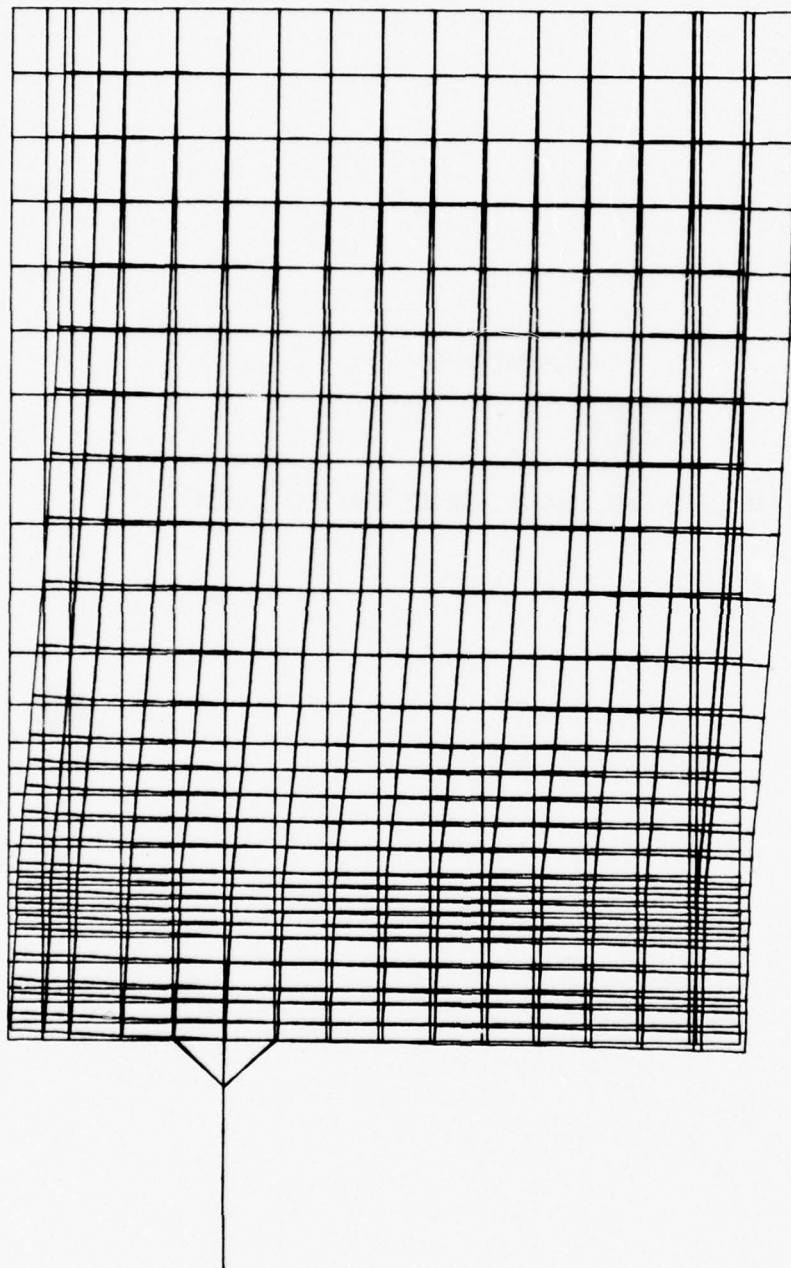

K.P. SCHWARTZ, ANALYSIS 1 (0 DEG. LAYERS=9, 90 DEG. LAYERS=1) HS
ACTUAL AIR CYCLE VANE (COMBINED LOADS)
ROVAC, RUN TEST CASE 2 AFFDL/FEMC, SCHWARTZ
STATIC DEFORMATION - SUBCASE 1 LOAD SET 20

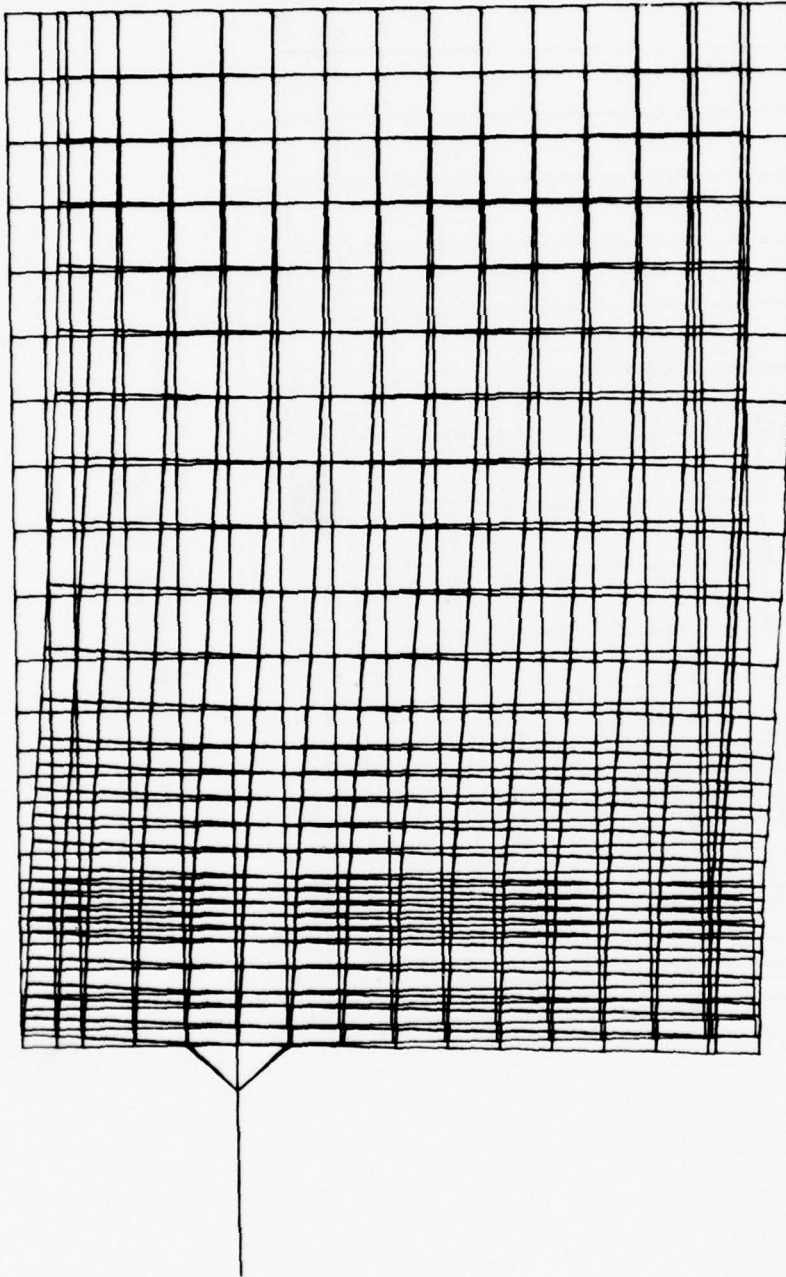

K.P. SCHWARTZ, ANALYSIS 2 (0 DEG. LAYERS*1, 90 DEG. LAYERS*1) HS
ACTUAL AIR CYCLE VANE (COMBINED LOADS)
ROVAC/RUN TEST CASE 2 AFFDL/FEMC, SCHWARTZ
STATIC DEFORMATION - SUBCASE 1 LOAD SET 30

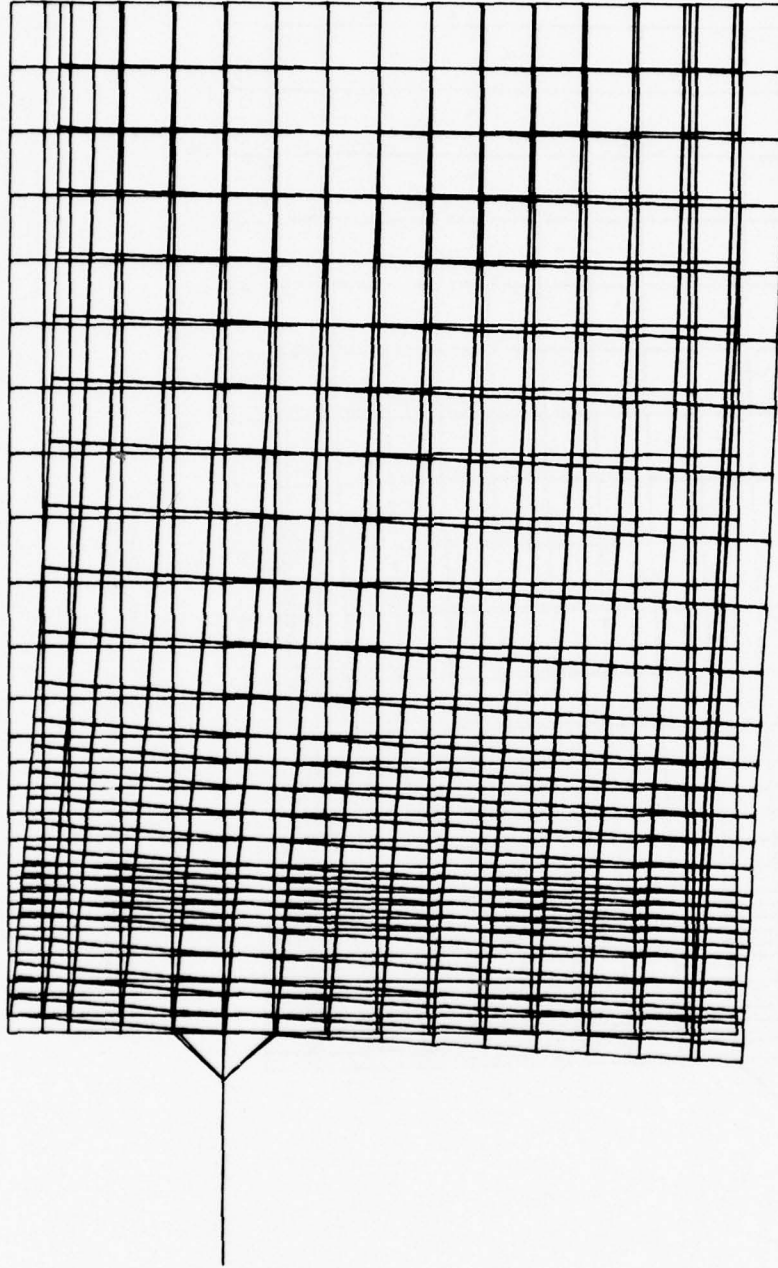

E.P. SCHWARTZ, ANALYSIS 3 (ALTERNATING +45, -45 DEG. LAYERS) MS
ACTUAL AIR CYCLE VANE (COMBINED LOADS)
ROVAC/RUN TEST CASE 2 AFFDL/FEMC, SCHWARTZ
STATIC DEFORMATION - SUBCASE 1 LOAD SET 90

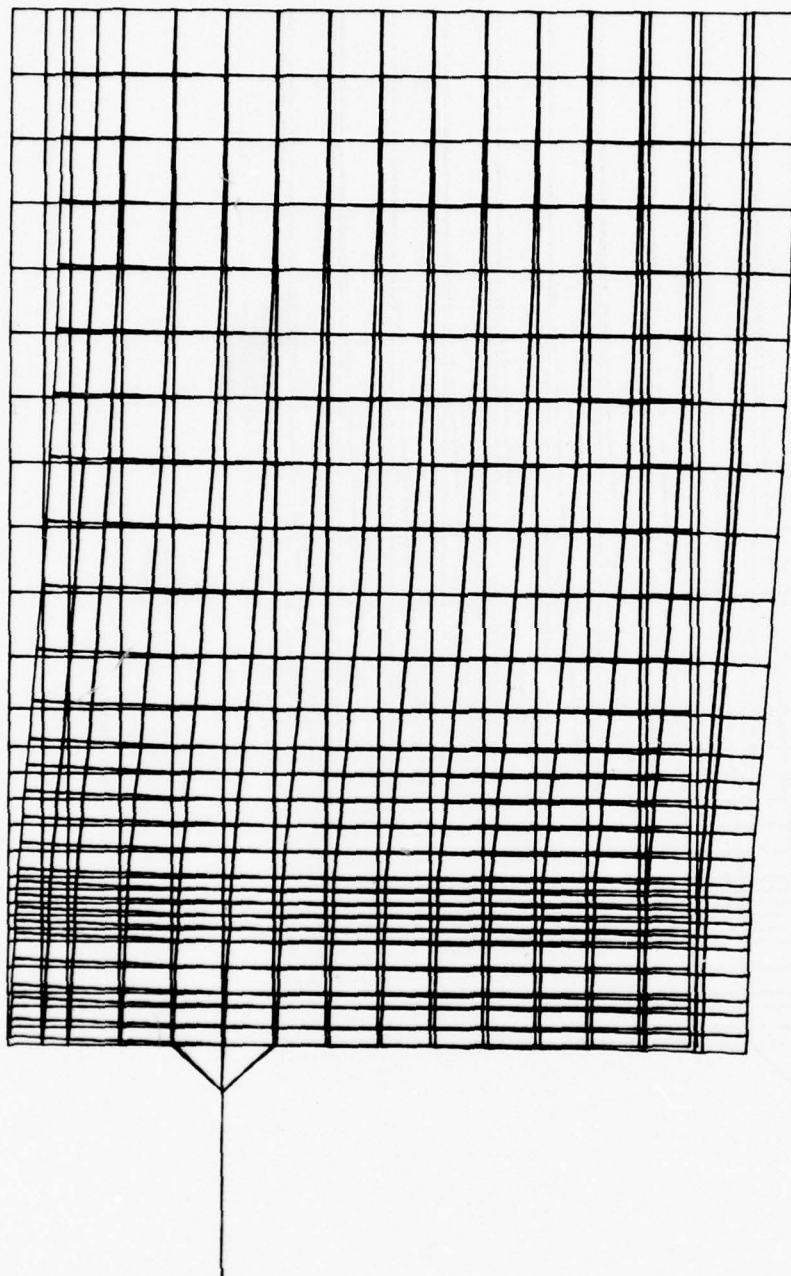

L.P. SCHWARTZ, ANALYSIS 4 (0 DEG. LAYERS=1, 90 DEG. LAYERS=1) MM
ACTUAL AIR CYCLE VANE (COMBINED LOADS)
ROVAC/RUN TEST CASE 2 AFFDL/FEMC, SCHWARTZ
STATIC DEFORMATION - SUBCASE 1 LOAD SET 90

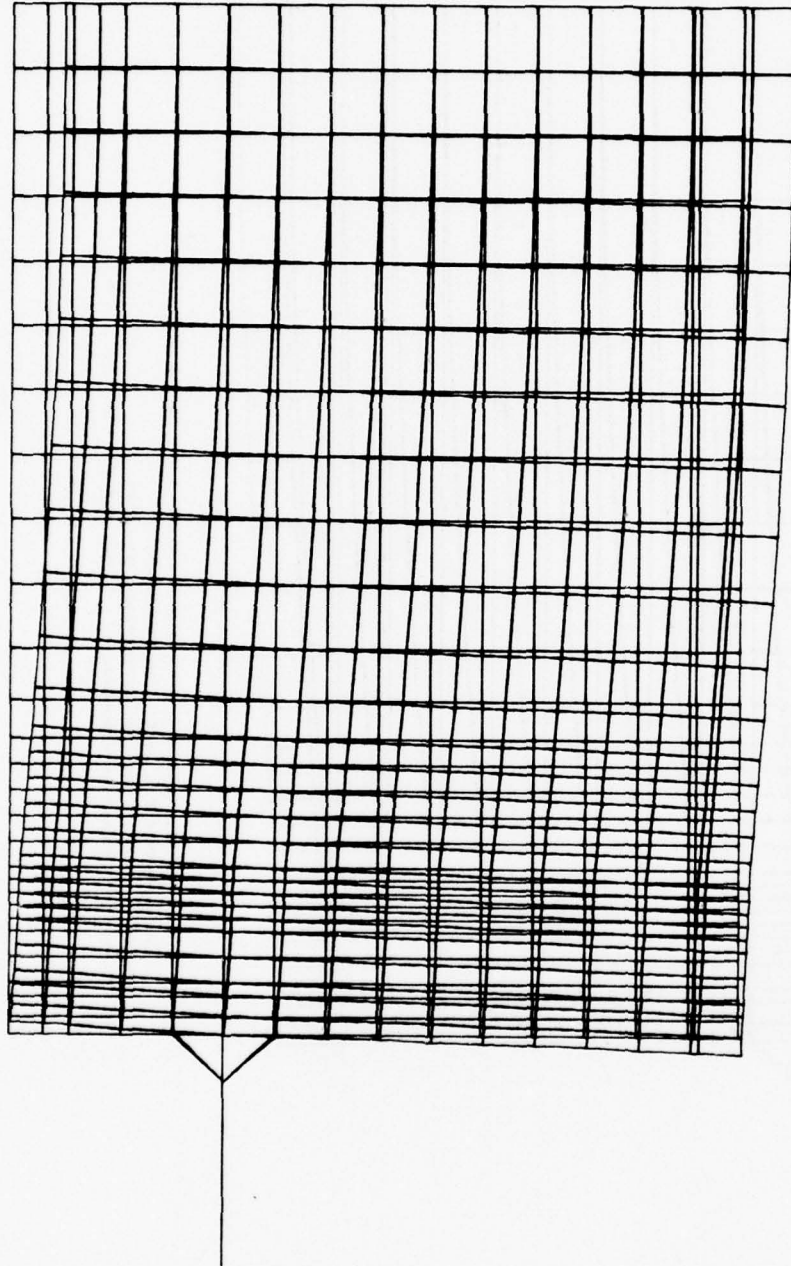

K. P. SCHWARTZ, ANALYSIS 5 (0 DEG. LAYERS=1, 90 DEG. LAYERS=9) HM
ACTUAL AIR CYCLE VANE (COMBINED LOADS)
ROVAC-RUN TEST CASE 2 AFFDL/FEMC, SCHWARTZ
STATIC DEFORMATION - SUBCASE 1 LOAD SET 30

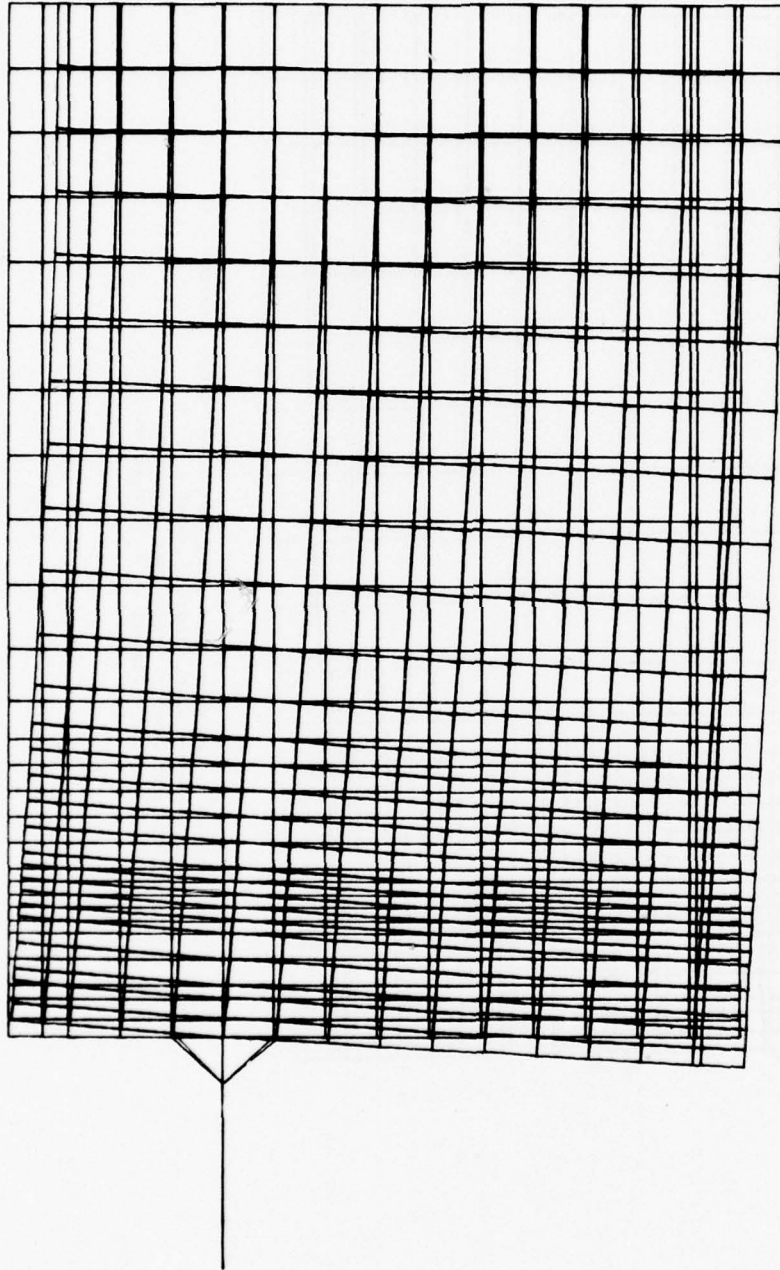

E.P. SCHWARTZ, ANALYSIS 6 (ALTERNATING +45, -45 DEG. LAYERS) MM
ACTUAL AIR CYCLE VANE (COMBINED LOADS)
ROVAC, RUN TEST CASE 2 AFFDL/FENC, SCHWARTZ
STATIC DEFORMATION - SUBCASE 1 LOAD SET 30

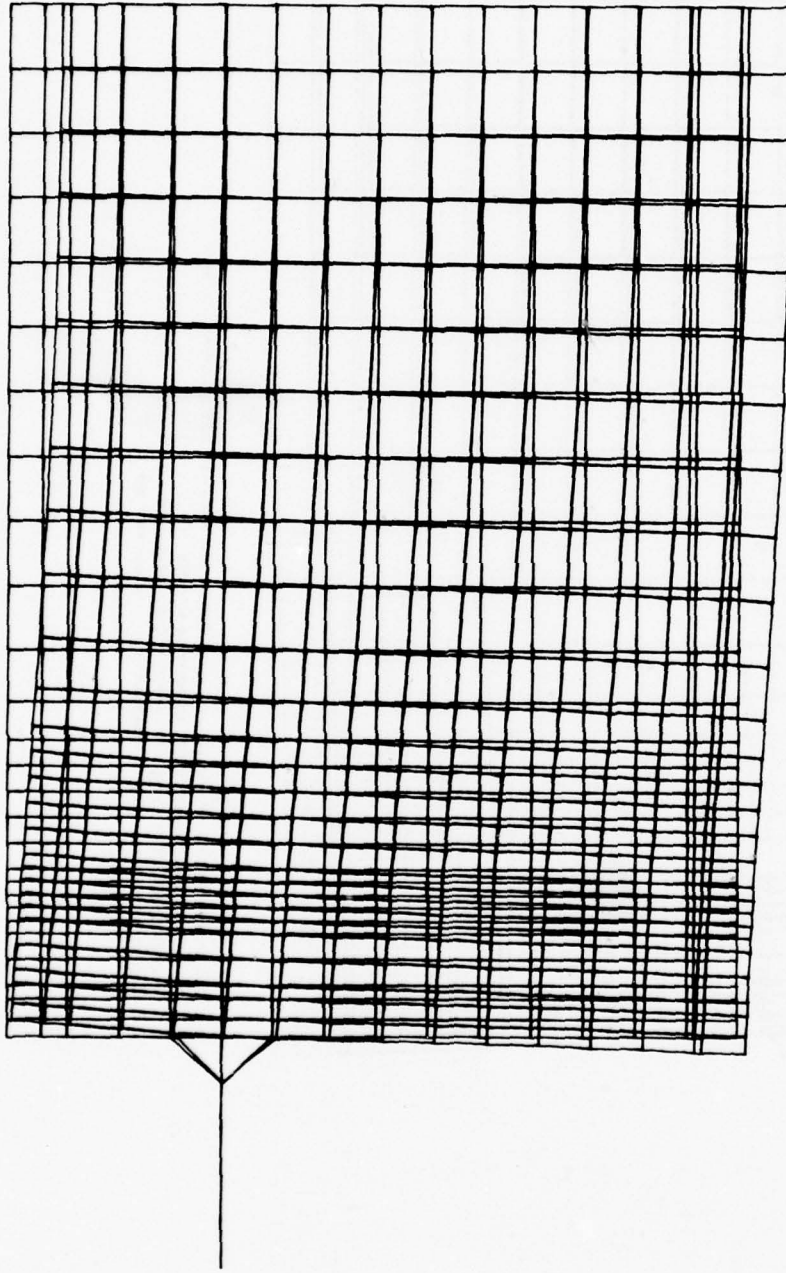

K.P. SCHWARTZ, ANALYSIS 7 (0 DEG, -9, +9, -15, +15, -10 DEG. LAYERS) AS
ACTUAL AIR CYCLE VANE (COMBINED LOADS)
ROYAC, RUN TEST CASE 2 AFFOL/TEMC, SCHWARTZ
STATIC DEFORMATION - SUBCASE 1 LOAD SET 30

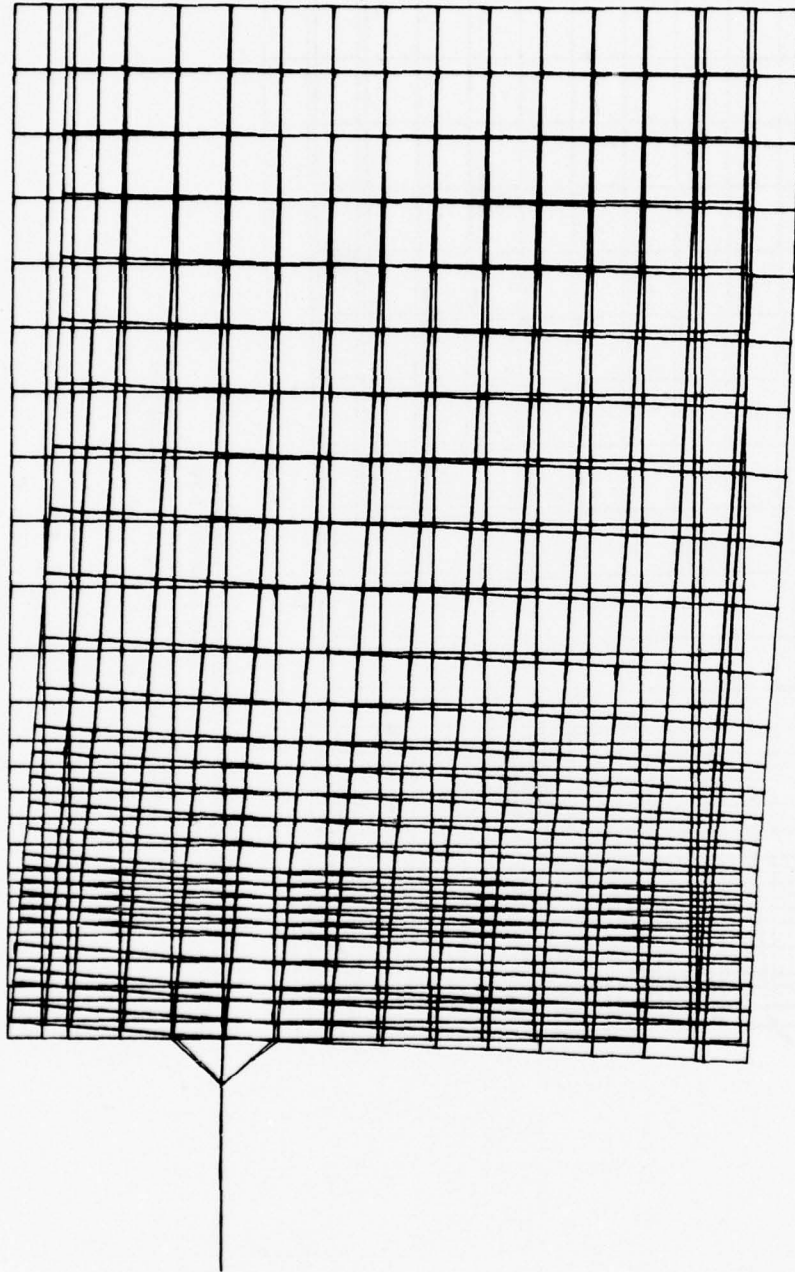

K.F. SCHWARTZ, ANALYSIS 8 (10 DEG. 3, 45, -45, 0 DEG. LAYERS) AS
ACTUAL AIR CYCLE VANE (COMBINED LOADS)
ROVAC. RUN TEST CASE 2 AFFDL/TEMC, SCHWARTZ
STATIC DEFORMATION - SUBCASE 1 LOAD SET 30

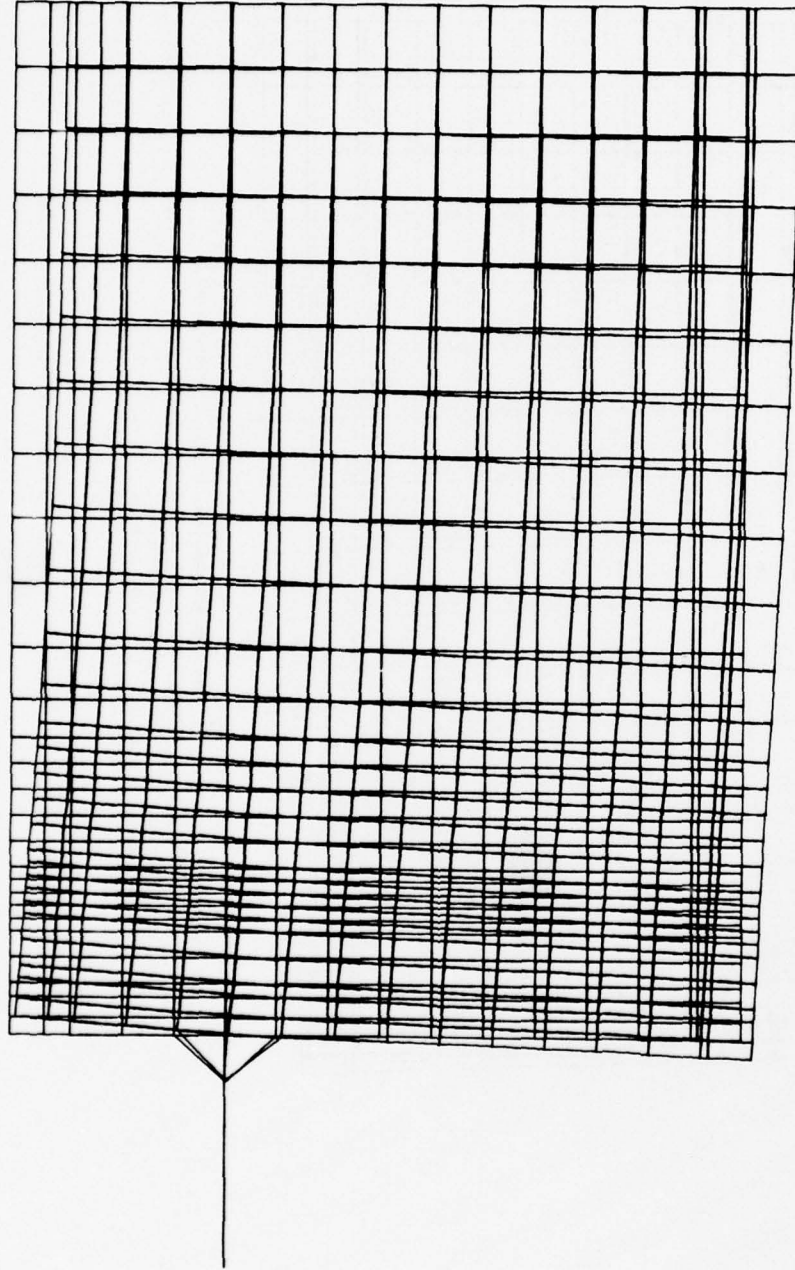

K.P. SCHWARTZ, ANALYSIS 9 (CHOPPED GRAPHITE MATERIAL)
ACTUAL AIR CYCLE VANE (COMBINED LOADS)
ROVAC/RUN TEST CASE 2 AFFDL/FEMC, SCHWARTZ
STATIC DEFORMATION - SUBCASE 1 LOAD SET 20

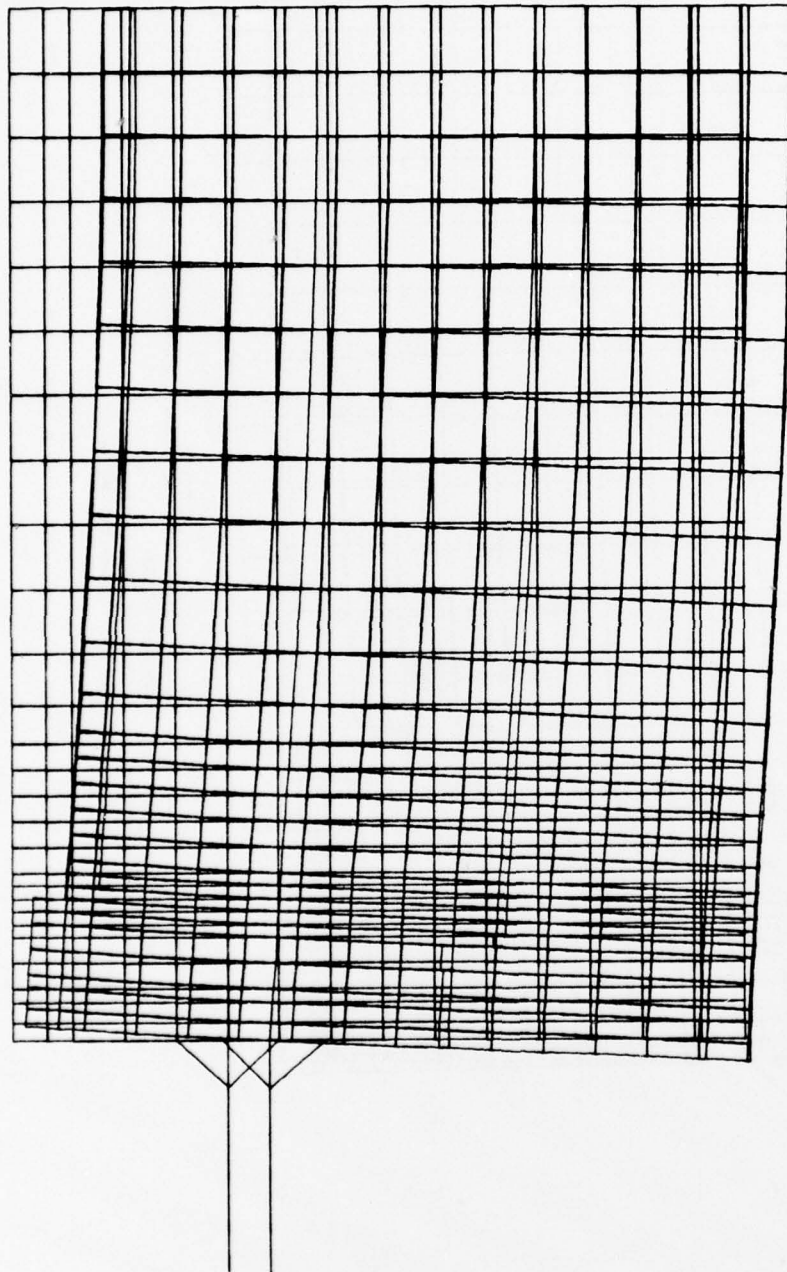

K.P. SCHWARTZ, ANALYSIS 10 (GRAPHITE COMPACT MATERIAL)
ACTUAL AIR CYCLE VANE (COMBINED LOADS)
ROYAC.RUN TEST CASE 2 AFFDL/FEMC, SCHWARTZ
STATIC DEFORMATION - SUBCASE 1 LOAD SET 30

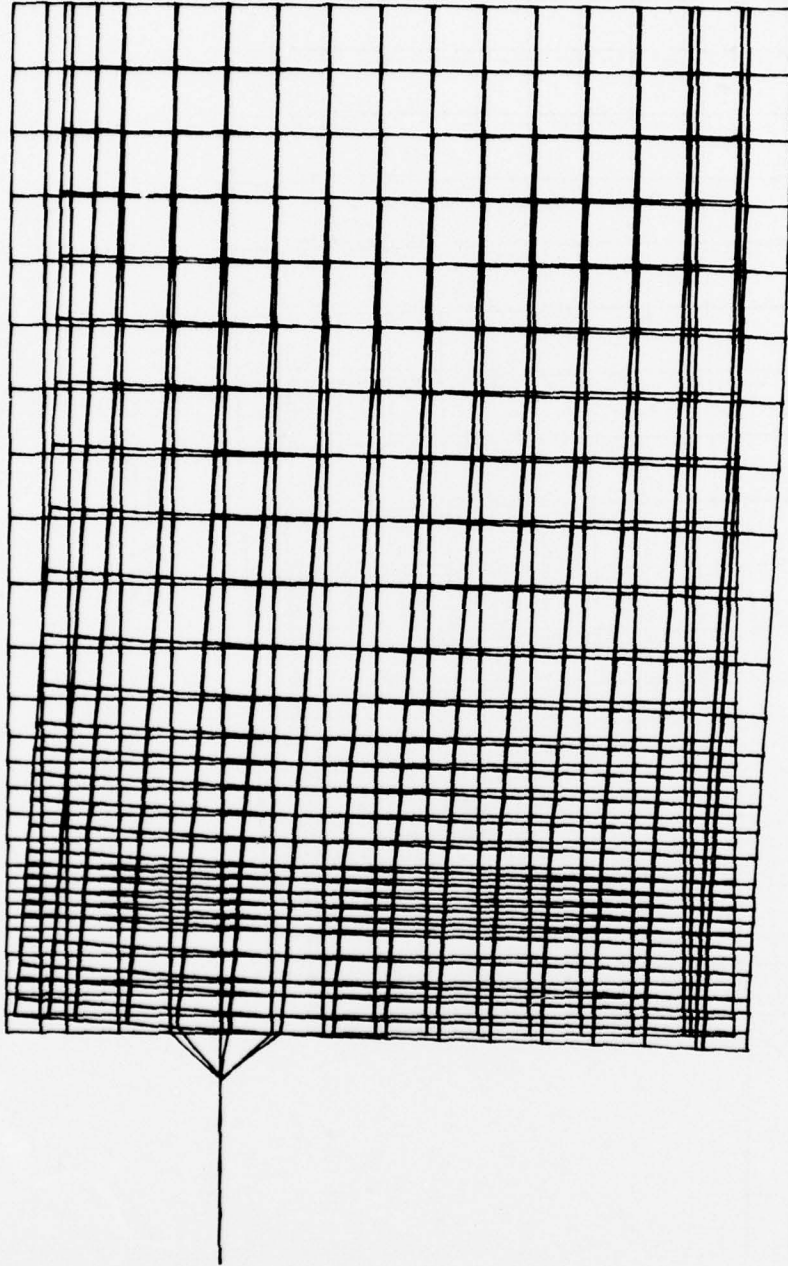

K.P. SCHWARTZ, NO ANGLES 7A (0 DEG, +3, +45, -45, 90 DEG. LAYERS) AS
ACTUAL AIR CYCLE VANE (COMBINED LOADS)
BOVAC/RUN TEST CASE 2 AFFOL/FENC, SCHWARTZ
STATIC DEFORMATION - SUBCASE 1 LOAD SET 30

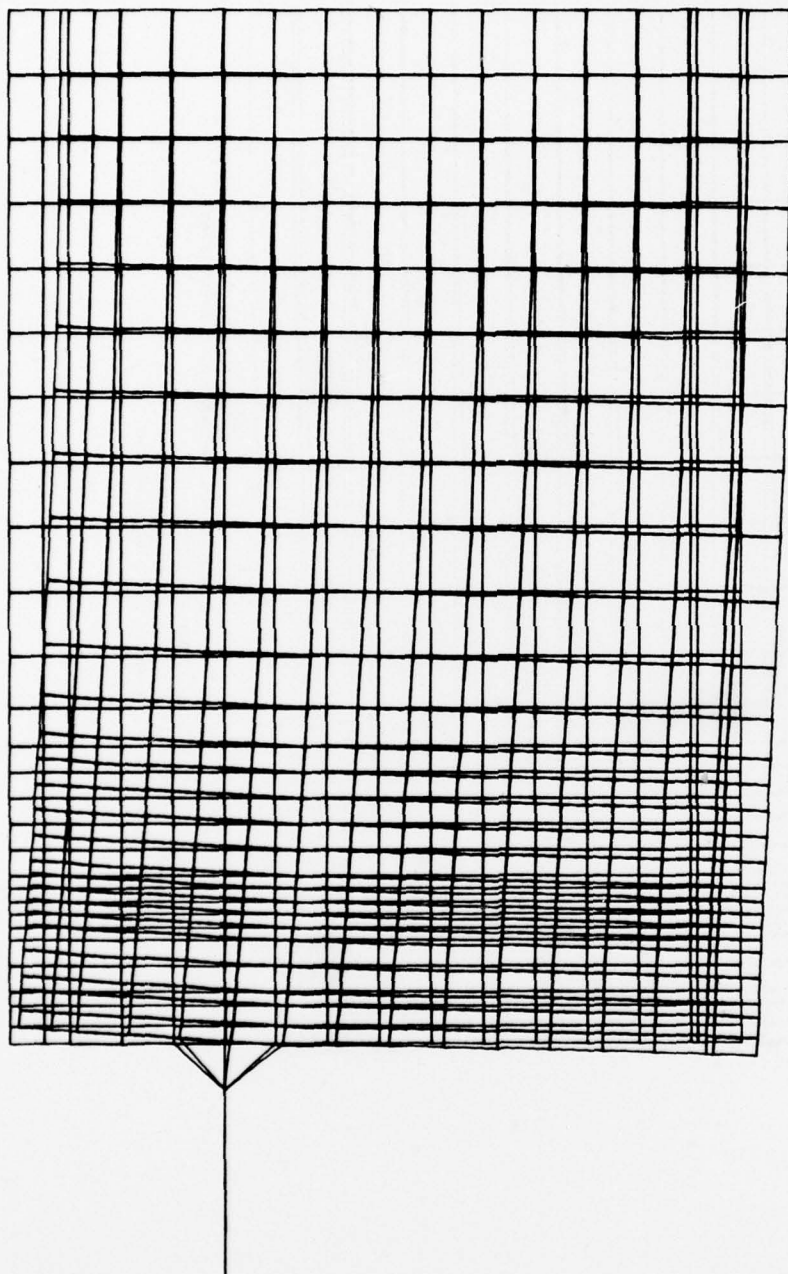

K.P. SCHWARTZ, NO BOOTS TB (0 DEG, +3, +45, -45, -90 DEG. LAYERS) AS
ACTUAL AIR CYCLE VANE (COMBINED LOADS)
ROVAC/RUN TEST CASE 2 AFFDL/FEMC, SCHWARTZ
STATIC DEFORMATION - SUBCASE 1 LOAD SET 30

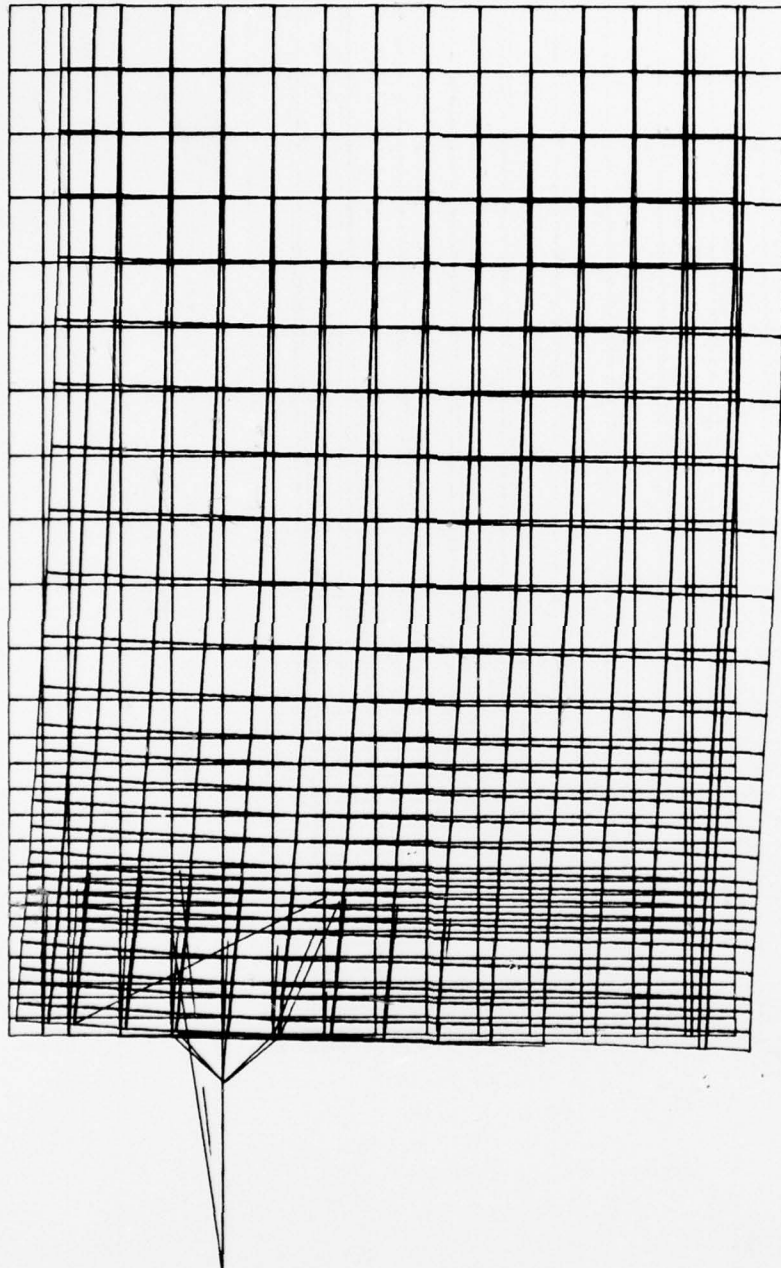

K.P. SCHWARTZ, TO SIZE TC (0 DEG, +3, +45, -45, 90 DEG, LAYERS) AS
ACTUAL AIR CYCLE VANE (COMBINED LOADS)
ROYAC, RUN TEST CASE 2 AFFDL/FEMC, SCHWARTZ
STATIC DEFORMATION - SUBCASE 1 LOAD SET 30

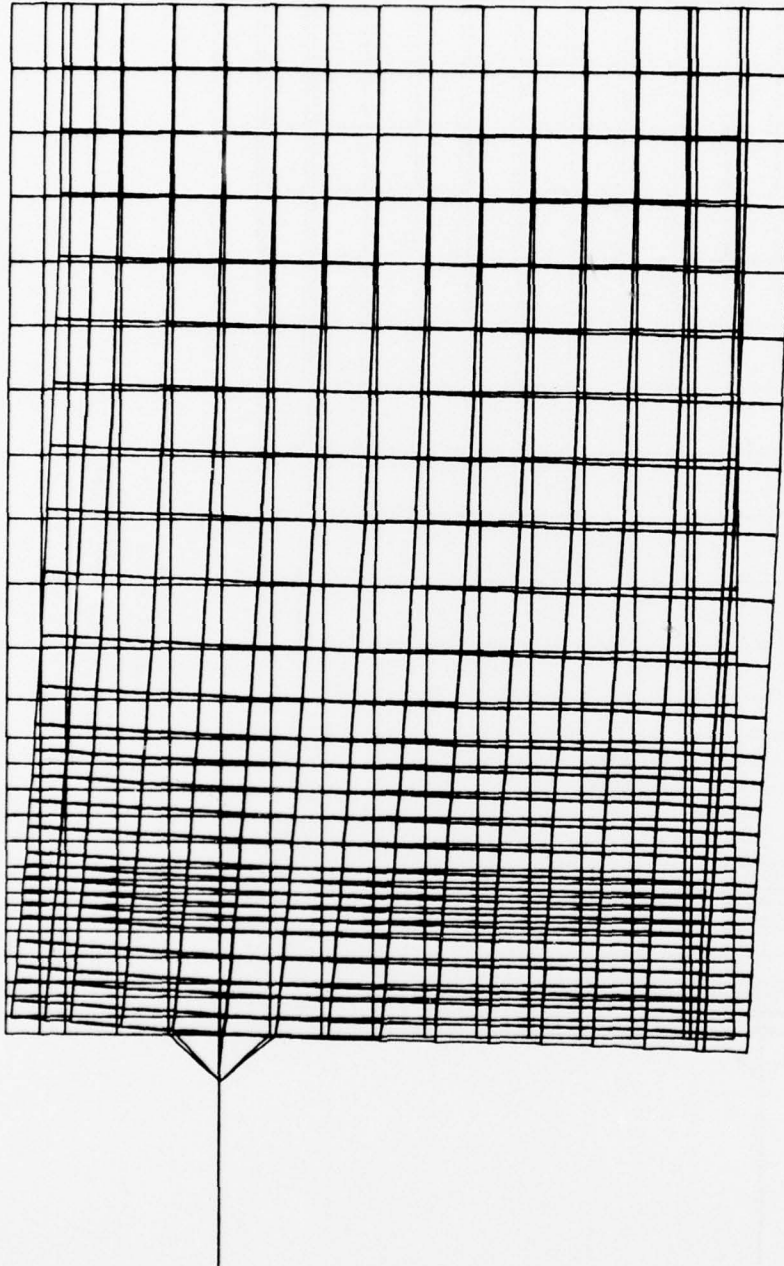

K.P. SCHWARTZ, 60 SIZE 70 (0 DEG., +3, +45, -45, 90 DEG. LAYERS) AS
ACTUAL AIR CYCLE VANE (COMBINED LOADS)
ROYAC-RUN TEST CASE 2 AFFDL/TEMC, SCHWARTZ
STATIC DEFORMATION - SUBCASE 1 LOAD SET 30

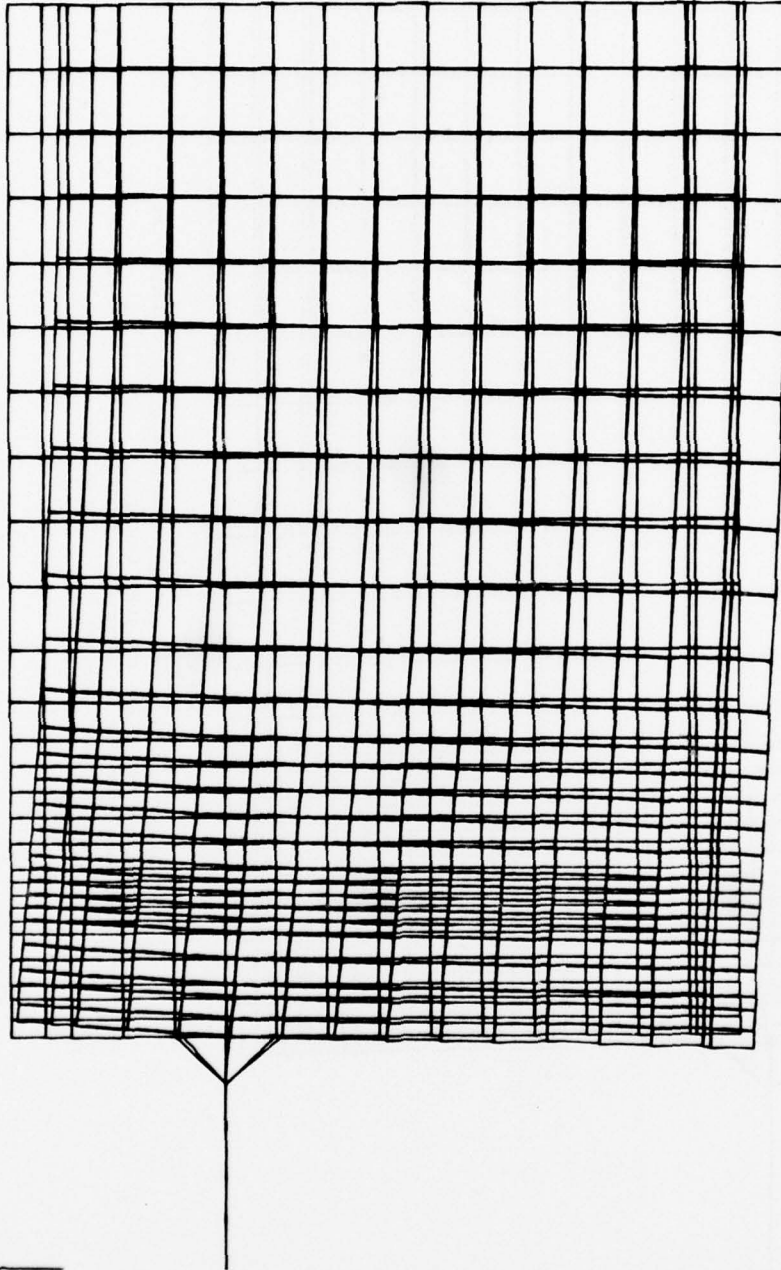

K. P. SCHWARTZ, 50 SIZE 7E (0 DEG. -9, +45, -45, 90 DEG. LAYERS) AS
ACTUAL AIR CYCLE VANE (COMBINED LOADS)
ROYAC. RUN TEST CASE 2 AFFDL/FEMC, SCHWARTZ
STATIC DEFORMATION - SUBCASE 1 LOAD SET 30

7F not available

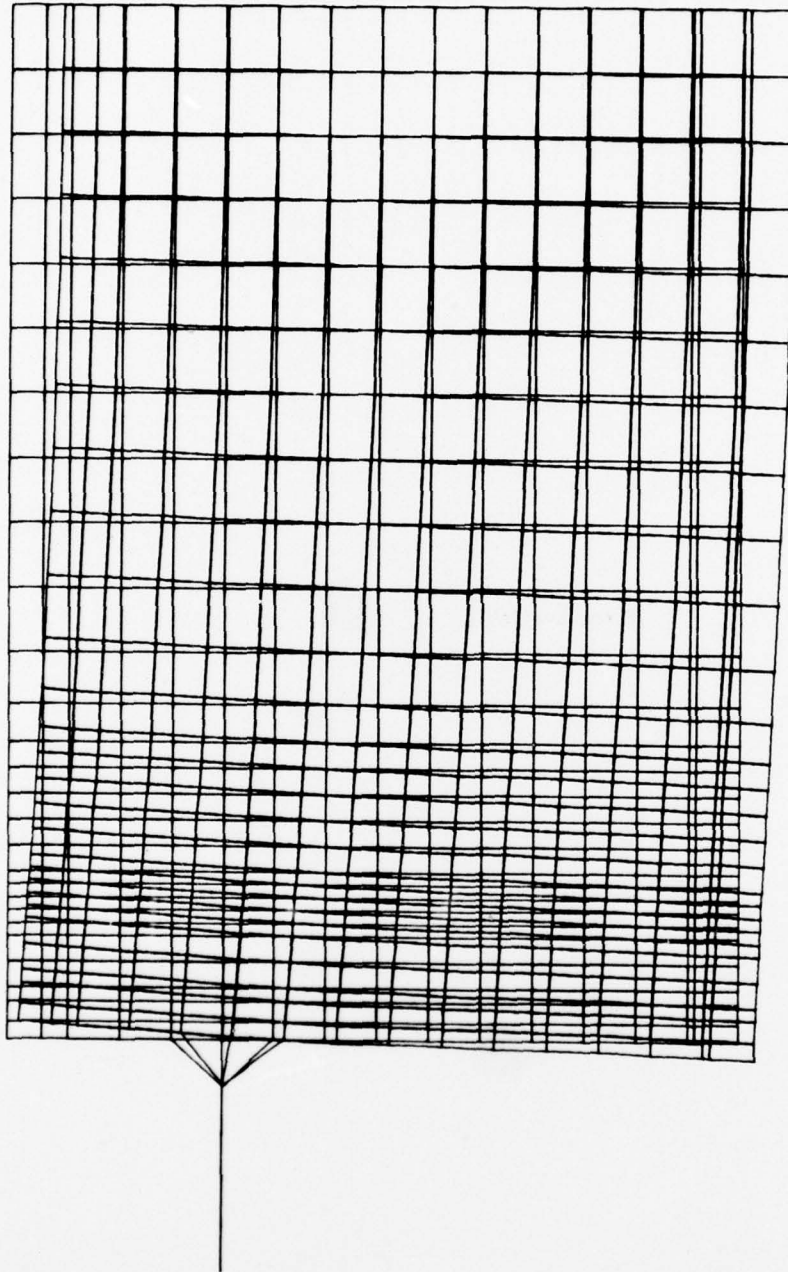

K. P. SCHWARTZ, NO AXLES 9A (CHOPPED GRAPHITE MATERIAL)
ACTUAL AIR CYCLE VANE (COMBINED LOADS)
ROVAC. RUN TEST CASE 2 AFFOL/FEMC, SCHWARTZ
STATIC DEFORMATION - SUBCASE 1 LOAD SET 30

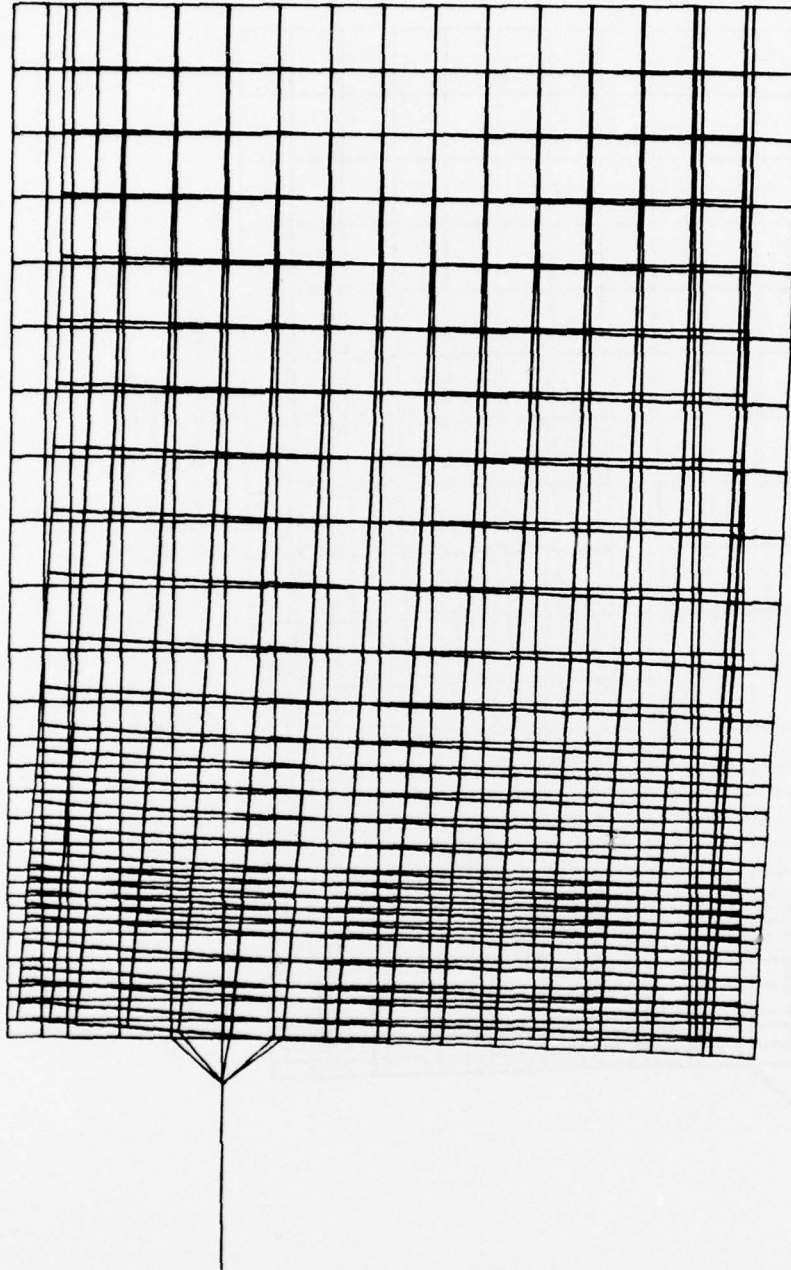

K. P. SCHWARTZ, NO BOOTS 18 (CHOPPED GRAPHITE MATERIAL)
ACTUAL AIR CYCLE VANE (COMBINED LOADS)
ROVAC/RUN TEST CASE 2 AFFDL/FEMC, SCHWARTZ
STATIC DEFORMATION - SUBCASE 1 LOAD SET 30

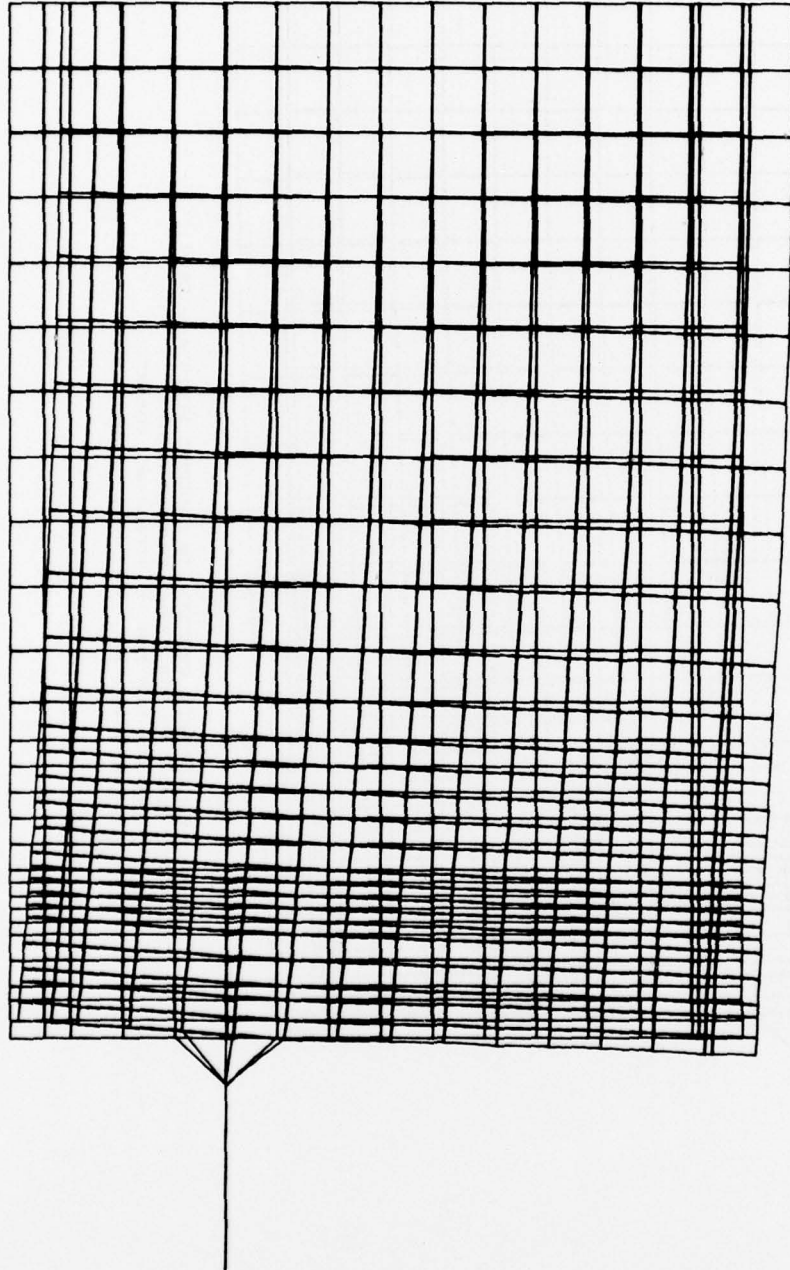

K.P. SCHWARTZ, TO SIZE 9C (CHOPPED GRAPHITE MATERIAL)
ACTUAL AIR CYCLE VANE (COMBINED LOADS)
ROVAC-RUN TEST CASE 2 AFFDL/FEMC, SCHWARTZ
STATIC DEFORMATION - SUBCASE 1 LOAD SET 30

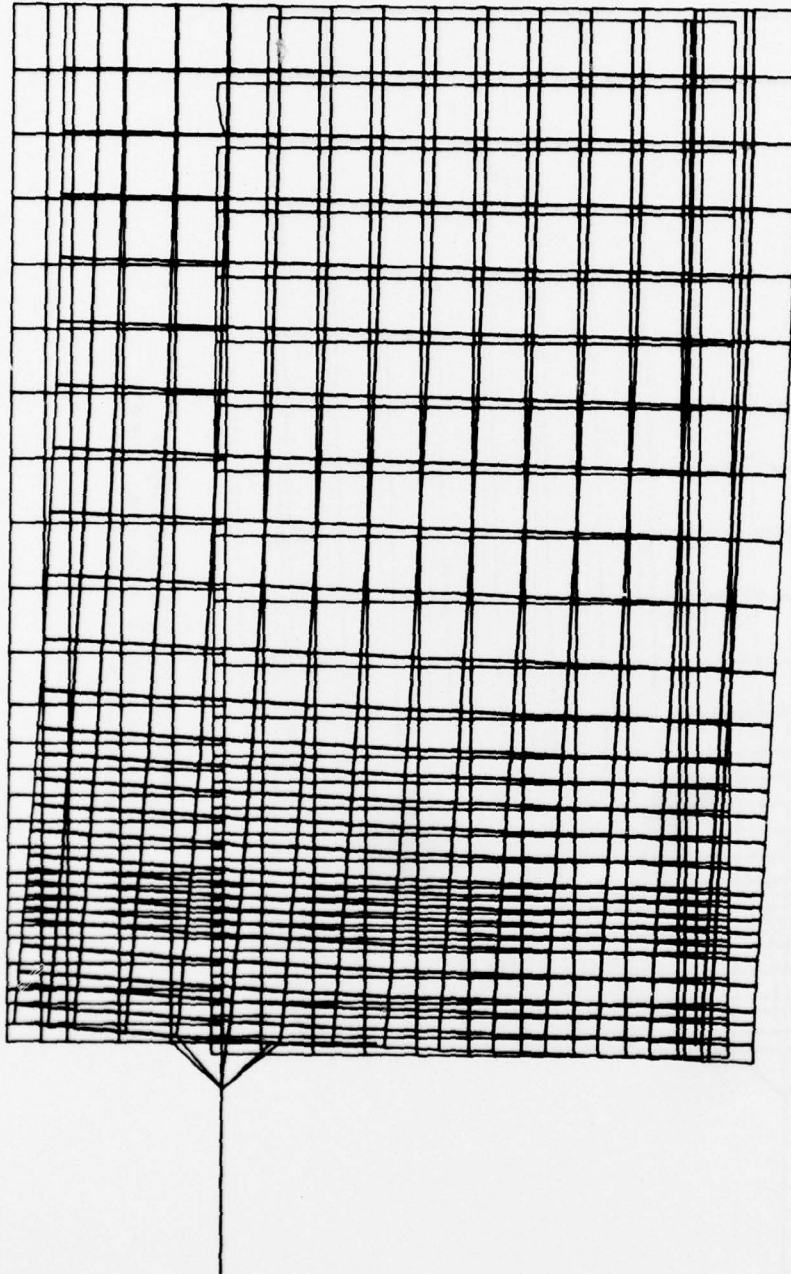

K.P. SCHWARTZ, 80 SIZE 90 (CHOPPED GRAPHITE MATERIAL.)
ACTUAL AIR CYCLE VANE (COMBINED LOADS)
BOVAC-RUN TEST CASE 2 AFFOL/FENC, SCHWARTZ
STATIC DEFORMATION - SUBCASE 1 LOAD SET 90

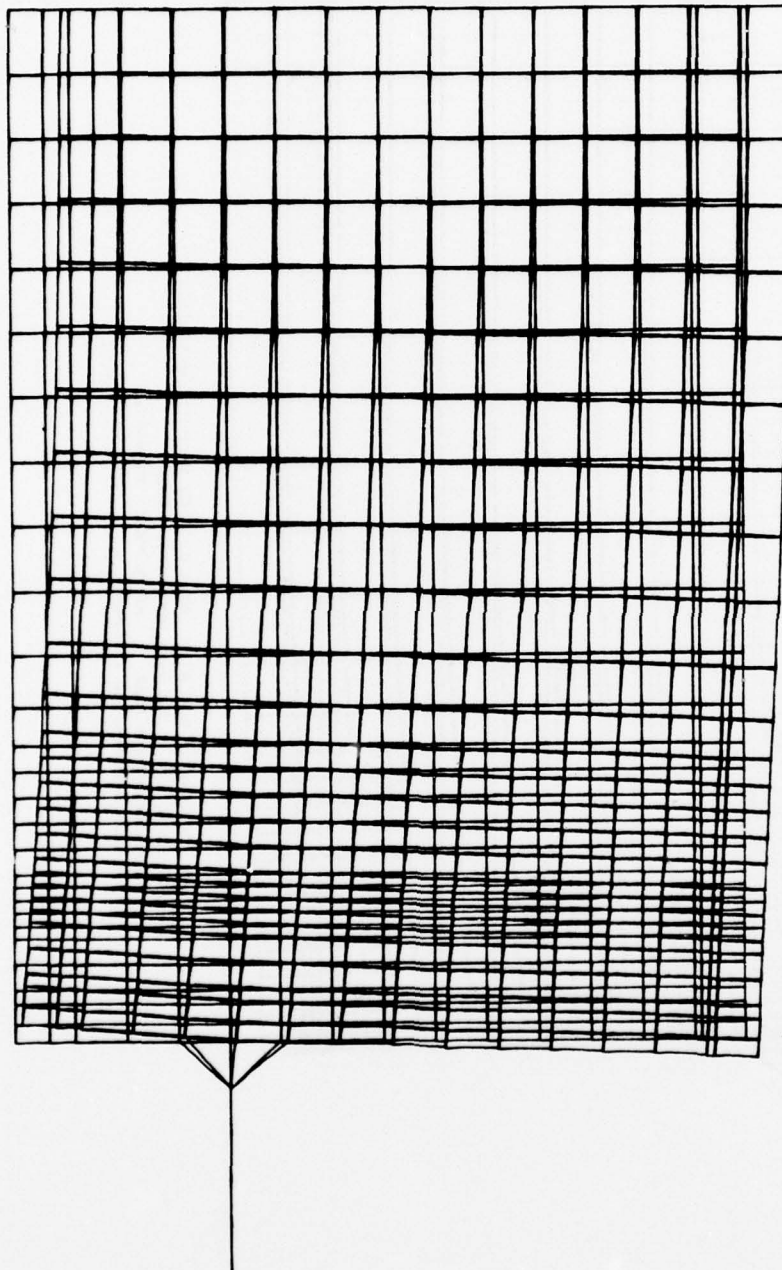

K.P. SCHWARTZ, 50 SIZE 9E (CHOPPED GRAPHITE MATERIAL)
ACTUAL AIR CYCLE VANE (COMBINED LOADS)
MOVAC-RUN TEST CASE 2 AFFDL/FEMC, SCHWARTZ
STATIC DEFORMATION - SUBCASE 1 LOAD SET 30

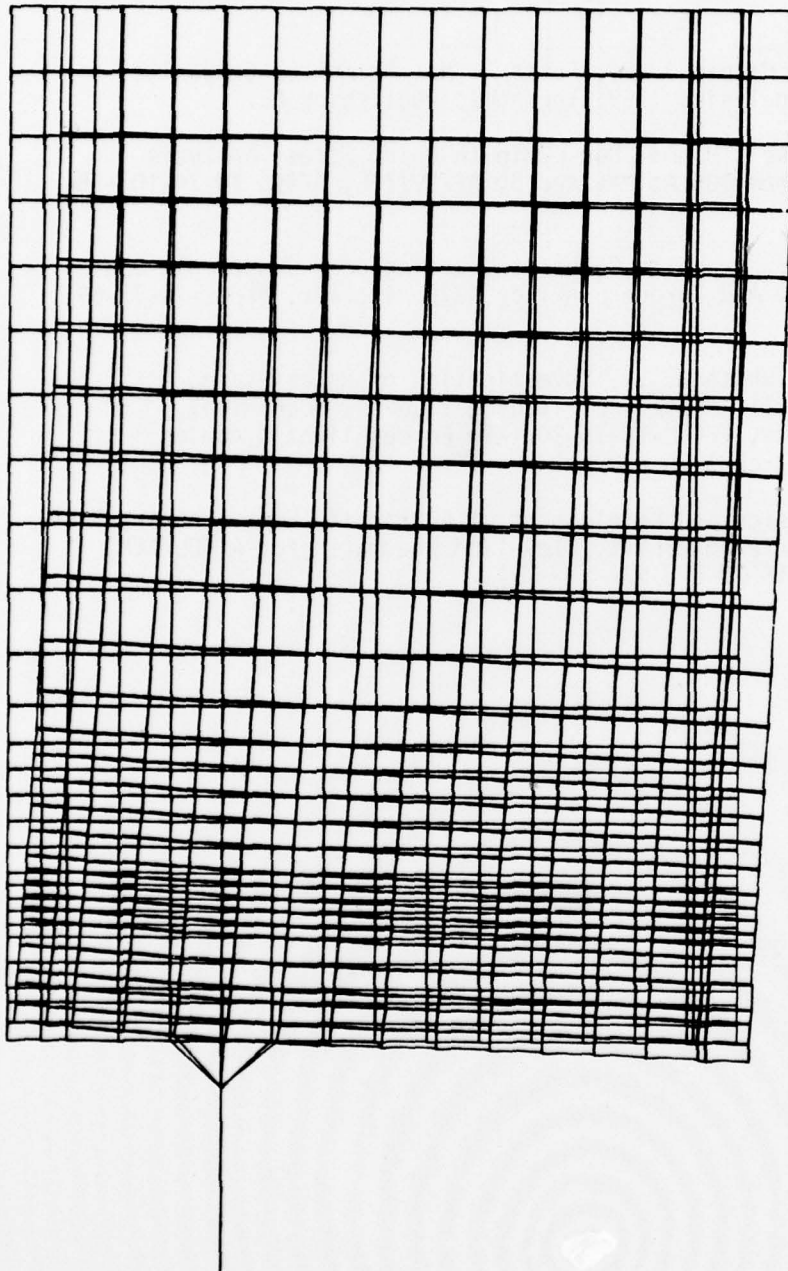

K. P. SCHWARTZ, 40 SIZE 9F (CHOPPED GRAPHITE MATERIAL)
ACTUAL AIR CYCLE VANE (COMBINED LOADS)
ROYAC.RUN TEST CASE 2 AFFOL./FEMC. SCHWARTZ
STATIC DEFORMATION - SUBCASE 1 LOAD SET 20

REFERENCES

1. Advanced Composites Design Guide, Third Edition, January 1973, by LAD of Rockwell International Corp., Dr. L. H. Lackman (Program Manager)
2. Ashton J. E., Halpin J. C., Petit P. H., Primer on Composite Materials: Analysis, 1969, Technomic Publishing Co.
3. Muha T. J., Users Manual For Laminate Point Stress Analysis Computer Program SQ5 As Revised By AFFDL/FBL, AFFDL TM-74-107-FBL, July 1974
4. Randolph R. E., Graphite Composite Landing Gear Components-Side Brace Assembly And Torque Link For A37B Aircraft, AFFDL-TR-73-69, May 1973
5. Corwin P. W., White H. V., Investigation of Rotary-vaned Air Cycle Cooler for Small Remotely Located Heat Loads, Mechanical Technology Inc., AFFDL-TR-75-20, Air Force Flight Dynamics Laboratory, March 1975
6. Beiber M., Design and Development of A Graphite Epoxy Landing Gear Drag Brace, Interim Report, Cleveland Pneumatic for AFFDL/FEM, Contract F33615-75-C-3152