

AD-A045 761

AIR FORCE FLIGHT DYNAMICS LAB WRIGHT-PATTERSON AFB OHIO F/O 1/3
DEVELOPMENT TESTS AND FLIGHT TEST OF GRAPHITE COMPOSITE LANDING--ETC(U)
JUL 77 P F DEXTER; G C SHUMAKER

UNCLASSIFIED

AFFDL-TR-77-86

NL

| OF |
AD
A045761



AD A 045761

AFFDL-TR-77-56

12
b.s

**DEVELOPMENT TESTS AND FLIGHT TEST OF GRAPHITE
COMPOSITE LANDING GEAR SIDE BRACE ASSEMBLY
FOR A-37B AIRCRAFT**

*PETER F. DEXTER, CAPTAIN, USAF
GERALD C. SHUMAKER*

*MECHANICAL BRANCH
VEHICLE EQUIPMENT DIVISION*

JULY 1977

DDC
RECEIVED
NOV 1 1977
F

TECHNICAL REPORT AFFDL-TR-77-56
Final Report for the Period 15 May 1973 to 15 March 1977

AU NO. 1
DDC FILE COPY

Approved for public release; distribution unlimited.

AIR FORCE FLIGHT DYNAMICS LABORATORY
AIR FORCE WRIGHT AERONAUTICAL LABORATORIES
AIR FORCE SYSTEMS COMMAND
WRIGHT-PATTERSON AIR FORCE BASE, OHIO 45433

NOTICE

When Government drawings, specifications, or other data are used for any purpose other than in connection with a definitely related Government procurement operation, the United States Government thereby incurs no responsibility nor any obligation whatsoever; and the fact that the government may have formulated, furnished, or in any way supplied the said drawings, specifications, or other data, is not to be regarded by implication or otherwise as in any manner licensing the holder or any other person or corporation, or conveying any rights or permission to manufacture, use, or sell any patented invention that may in any way be related thereto.

This report has been reviewed by the Information Office (OI) and is releasable to the National Technical Information Service (NTIS). At NTIS, it will be available to the general public, including foreign nations.

This technical report has been reviewed and is approved for publication.

Peter F. Dexter

PETER F. DEXTER, CAPT, USAF
Project Engineer

Gerald C. Shumaker

GERALD C. SHUMAKER
Project Engineer

FOR THE COMMANDER:

Huwell K. Brewer

Chief, Mechanical Branch
Vehicle Equipment Division

ACCESSION for	By Function
NTIS	<input checked="" type="checkbox"/>
NDC	B. I. Section <input type="checkbox"/>
J. S.	<input type="checkbox"/>
BY	DISTRIBUTION/AVAILABILITY CODES
A	CONFIDENTIAL

Copies of this report should not be returned unless return is required by security considerations, contractual obligations, or notice on a specific document.

UNCLASSIFIED

SECURITY CLASSIFICATION OF THIS PAGE (When Data Entered)

REPORT DOCUMENTATION PAGE		READ INSTRUCTIONS BEFORE COMPLETING FORM
1. REPORT NUMBER AFFDL-TR-77-56 ✓	2. GOVT ACCESSION NO.	3. RECIPIENT'S CATALOG NUMBER
4. TITLE (and Subtitle) Development Tests and Flight Test of Graphite Composite Landing Gear Side Brace Assembly for A-37B Aircraft.	5. TYPE OF REPORT & PERIOD COVERED Final Technical Report. 15 May 73 - 15 Mar 77.	6. PERFORMING ORG. REPORT NUMBER
7. AUTHOR(s) Peter F./Dexter, Capt, USAF Gerald C./Shumaker	8. CONTRACT OR GRANT NUMBER(s)	
9. PERFORMING ORGANIZATION NAME AND ADDRESS Mechanical Branch, Vehicle Equipment Division Air Force Flight Dynamics Laboratory ✓ Wright-Patterson AFB, Ohio 45433	10. PROGRAM ELEMENT, PROJECT, TASK AREA & WORK UNIT NUMBERS 1369 0003 1703	
11. CONTROLLING OFFICE NAME AND ADDRESS	12. REPORT DATE JUL 1977	
14. MONITORING AGENCY NAME & ADDRESS (if different from Controlling Office) 12 59 po	13. NUMBER OF PAGES 52	15. SECURITY CLASS. (of this report)
16. DISTRIBUTION STATEMENT (of this Report) Approved for public release; distribution unlimited		
17. DISTRIBUTION STATEMENT (of the abstract entered in Block 20, if different from Report)		
18. SUPPLEMENTARY NOTES		
19. KEY WORDS (Continue on reverse side if necessary and identify by block number) Composite Graphite Landing Gear Flight Test		
20. ABSTRACT (Continue on reverse side if necessary and identify by block number) This report describes the successful development, in-house testing, and flight testing of a graphite/epoxy side brace for the A-37B aircraft landing gear.		

012070 ✓

LB

FOREWORD

This report is the result of an extensive in-house effort conducted under Project 1369, "Mechanical Systems for Advanced Military Flight Vehicles," Work Unit 13690343, "Lab Test and Evaluation of Composite Material Aircraft Landing Gear Hardware." The experimental work was performed by the Air Force Flight Dynamics Laboratory in cooperation with the 4950th Test Wing and the Air Force Materials Laboratory.

The work reported herein was conducted from May 1973 to March 1977 by Capt. Peter F. Dexter and Mr. Gerald C. Shumaker, engineers in the Mechanical Branch, Vehicle Equipment Division, Air Force Flight Dynamics Laboratory.

The authors wish to thank Mr. George Holderby, Test Engineer, Structures Division, AFFDL; Mr. Ronald Selner of Universal Technology Corporation; Capt. Gene Peterson, Flight Test Engineer, 4950th Test Wing; and Mrs. Patricia Cazad, Vehicle Equipment Division, AFFDL for their assistance in this program.

TABLE OF CONTENTS

Section		Page
I	INTRODUCTION	1
II	HARDWARE DESCRIPTION AND APPLICATION	3
III	FATIGUE TESTS	7
IV	ENVIRONMENTAL TESTS	28
V	CERTIFICATION FOR AIRWORTHINESS	34
	A. Instrumentation	36
	B. Nondestructive Inspection	36
	C. Proof Tests	38
	D. Taxi, Turns	40
	E. Initial Flight Testing, Landings	44
VI	SERVICE TEST	46
VII	FOLLOW-ON TESTS	47
VIII	CONCLUSIONS	48
	REFERENCES	48
	APPENDIX A - GRAPHITE SIDE BRACE TEST FATIGUE SPECTRUM	49
	APPENDIX B - PROOF TEST STRAIN VS LOAD	50
	APPENDIX C - MAXIMUM LOADS & STRAIN	51
	APPENDIX D - SAMPLE STRAIN DATA	52

PRECEDING PAGE BLANK-NOT FILMED

LIST OF ILLUSTRATIONS

Figure		Page
1	A-37B COMPOSITE MAIN LANDING GEAR	2
2	SIDE BRACE LOCKS MAIN LANDING GEAR DOWN	5
3	GRAPHITE/EPOXY SIDE BRACE AND ITS METAL COUNTERPART . .	6
4	UPPER SIDE BRACE COMPONENTS AND THE FINISHED MOLDED PART	6
5	FATIGUE TEST OF COMPLETE SIDE BRACE ASSEMBLY	7
6	S/N 1 UPPER AND LOWER MEMBERS AFTER FAILURE OR LOWER MEMBER AT 1.9 LIFETIMES	11
7	FATIGUE FAILURE OF S/N 1 LOWER MEMBER AT 1.9 LIFETIMES.	12
8	COMPARISON BETWEEN BROKEN S/N 1 LOWER MEMBER AND SUBSTITUTE S/N 2 LOWER MEMBER AFTER 4 LIFETIMES	13
9	STRAIN GAGE NUMBER AND LOCATION	14
10	TANG STRAIN GAGE CALIBRATION	15
11	CALIBRATION OF SG11 AND SG12	16
12	FATIGUE CRACK ON S/N 1 UPPER MEMBER AFTER 4 LIFETIMES .	18
13	FATIGUE CRACK ON S/N 1 UPPER MEMBER AFTER 5 LIFETIMES .	19
14	FAILURE OF S/N 1 UPPERS AND S/N 2 LOWERS AFTER 25% INCREASED LOAD (6 LIFETIMES ON UPPERS)	20
15	FAILED S/N 2 LOWER MEMBER AFTER 25% INCREASED LOAD (4.1 LIFETIMES ON LOWER MEMBER)	21
16	FAILED S/N 1 UPPER MEMBERS AFTER 25% INCREASED LOAD (6 LIFETIMES ON UPPER MEMBERS)	22
17	TYPICAL STRAIN DATA FROM THE S/N 3 ASSEMBLY AFTER 2 LIFETIMES	24
18	TYPICAL STRAIN DATA FOR THE S/N 3 ASSEMBLY SUBJECTED TO A 25% INCREASE IN FATIGUE LOADS	25

LIST OF ILLUSTRATIONS (CONT'D)

Figure		Page
19	FAILED S/N 3 LOWER MEMBER	26
20	X-RAYS SHOWING FIBER WASH AND VOIDS (LIGHT AREAS) NEAR BUSHING OF SN6 AND SN14	30
21	ULTRASONIC C-SCANS SHOWING POSSIBLE DELAMINATIONS (LIGHT AREAS) NEAR ENDS OF SN6	32
22	SECTIONED VIEWS OF DEFECTIVE SIDE BRACES SHOWING VOIDS, LACK OF FIBER, AND SOME FRACTURE DAMAGE FROM STATIC TESTS	33
23	SIDE BRACE INSTALLED ON T-37, READY FOR FLIGHT TEST . .	35
24	FLIGHT TEST SIDE BRACE WITH STRAIN GAGES AND WIRING . .	377
25	SIDE BRACE DURING PROOF TEST	39
26	FAILED LOWER MEMBER OF SIDE BRACE, RESULT OF OVERLOAD DURING PROOF TEST	41
27	GRAPHITE SIDE BRACE ON T-37 DURING SERVICE TEST	45

SECTION I

INTRODUCTION

The objective of the Composite Landing Gear Program was to demonstrate the feasibility of full scale composite material landing gear in order to solve the traditional problems of weight, corrosion, and fatigue. The approach was to completely replace the main landing gear of the A-37B fighter aircraft with composite material hardware.

Some of the hardware to come out of this program were the graphite/epoxy trunnion and outer cylinder, torque links, wheel, and side brace (Figure 1). The side brace was one of the first items to be developed and is currently undergoing flight testing and an extended service test on a T-37 aircraft at Wright-Patterson Air Force Base. This paper discusses the extensive development, certification, and actual flight test experience of the graphite side brace assembly.

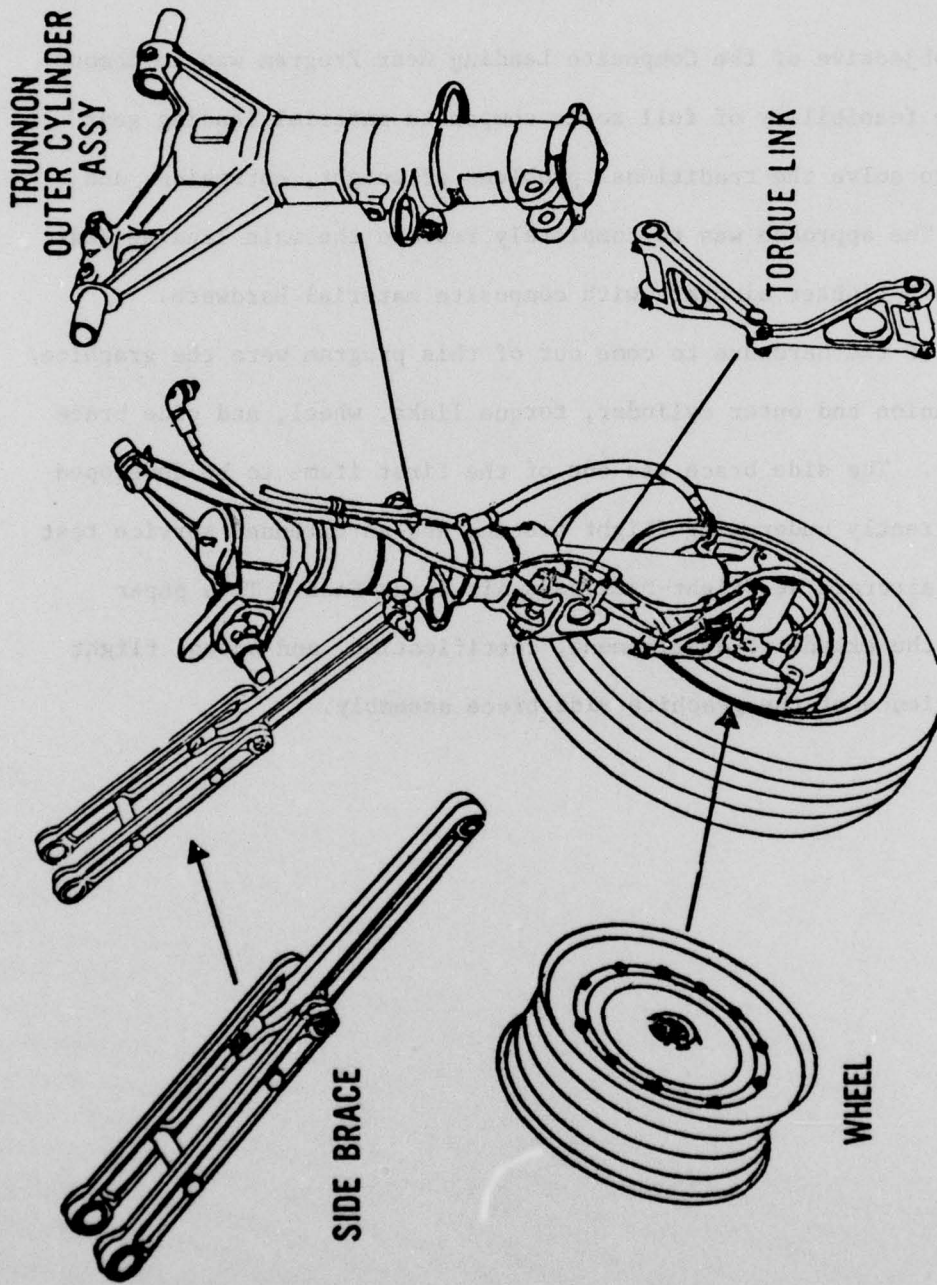

Figure 1. A-37B Composite Main Landing Gear

SECTION II

HARDWARE DESCRIPTION AND APPLICATION

The side brace assembly is a folding brace whose function is to lock the main landing gear in place (Figures 2 and 3). The aluminum side brace is designed to an ultimate (150 percent design limit) tensile load of 13,800 lb and an ultimate compression load of 29,800 lb. As shown, these loads are transmitted through pinned joints. When loaded in compression, the side brace is stabilized by a locked retraction mechanism which attaches to the upper cross bolt. This retraction mechanism acts as a fixed member to reduce the buckling tendency of the side brace.

The load conditions giving the maximum part loads are summarized in the following tabulation, where (-) indicates compression and (+) indicates tension. These loads were determined through engineering analysis.

<u>Load Condition</u>		<u>Side Brace Load (lb)</u>
2 Point Level Landing	a) Max Vertical	-10,400
	b) Spin Up	- 4,600
	c) Spring Back	- 8,600
Tail Down Landing	a) Max Vertical	-10,000
	b) Spring Back	- 6,400
Drift Landing	a) Right	+13,800
	b) Left	-29,800
Braked Roll		- 7,000
Reverse Brake		- 7,000
Right Turn		-29,600

The graphite composite side brace assembly weighs about two pounds,

some 40% lighter than its aluminum counterpart. It is fully interchangeable with the original assembly and is designed for the same loads.

The principal structural role of both the upper and lower side brace components is that of a tension-compression member, with a small moment caused by the overcenter locking mechanism. They are both of an I-beam configuration with pinned ends for load transfer.

The upper side brace consists of an oriented fiber web between two metal bushings (load points) and a continuous oriented band or "race track" surrounding the entire structure. Chopped graphite subcomponents provide (a) a blend or fillet between the web and the flange, (b) hard points within the body of the structure, and (c) a shear load path between the metal bushing and the oriented fibers during compression loading (Figure 4).

As with the upper side braces, the lower side brace consists of an oriented fiber web between metal bushings and continuous oriented fiber bands to form the flanges. The flange, however, is split at the tang end bushing, and a portion of it is continued out to the end of the tang.

The subcomponents, described above, were fabricated from Hercules 2002T prepreg or chopped graphite/epoxy and then "B-staged" or partially cured. The subcomponents are placed in the female portion of a graphite/epoxy mold, the mold closed, and the subcomponents co-cured under heat and pressure to form an integral structural part. Final curing takes place at 350°F. The design development, tooling and fabrication development, and static test of this hardware is summarized in Reference 1.

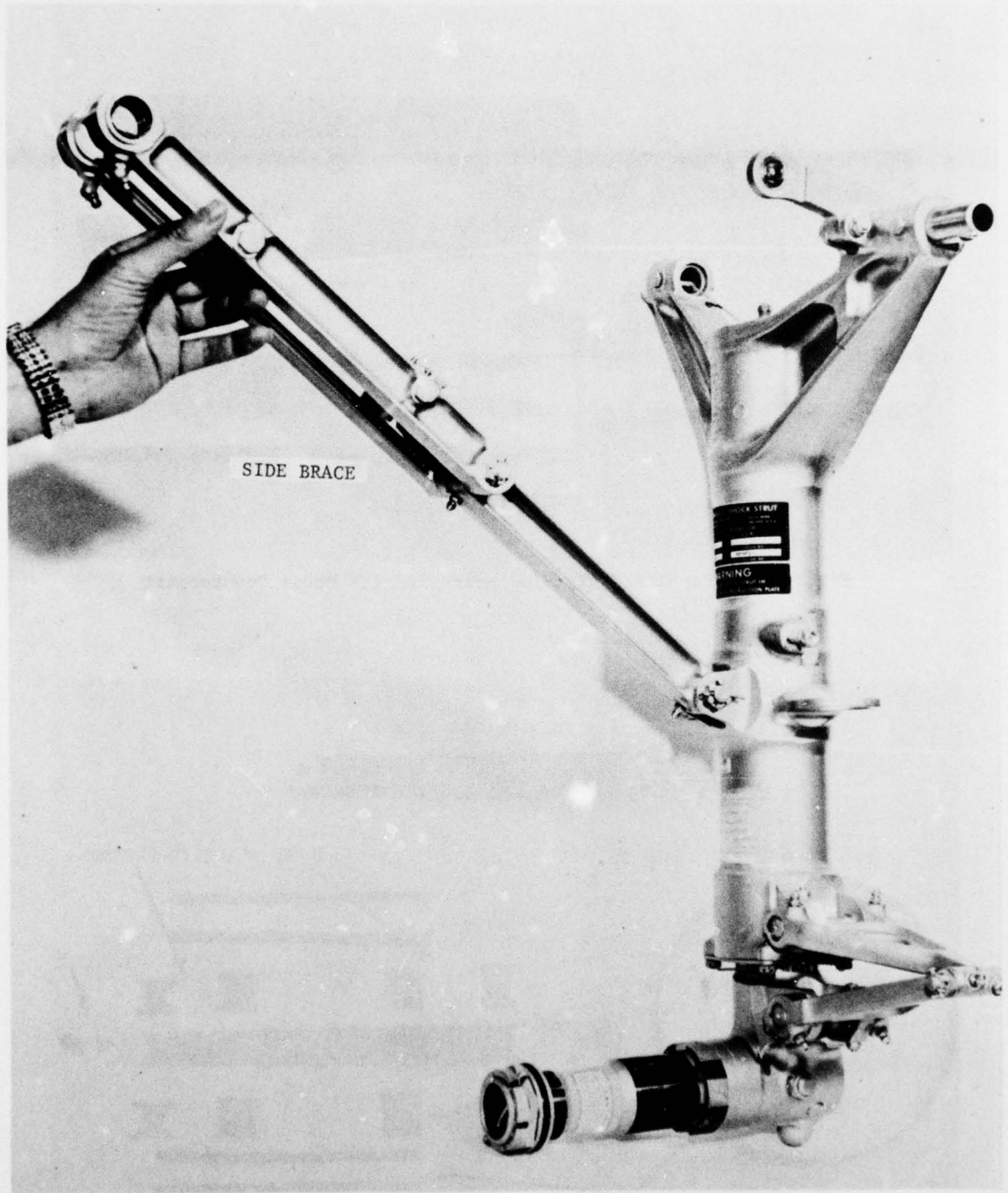

Figure 2. Side Brace Locks Main Landing Gear Down

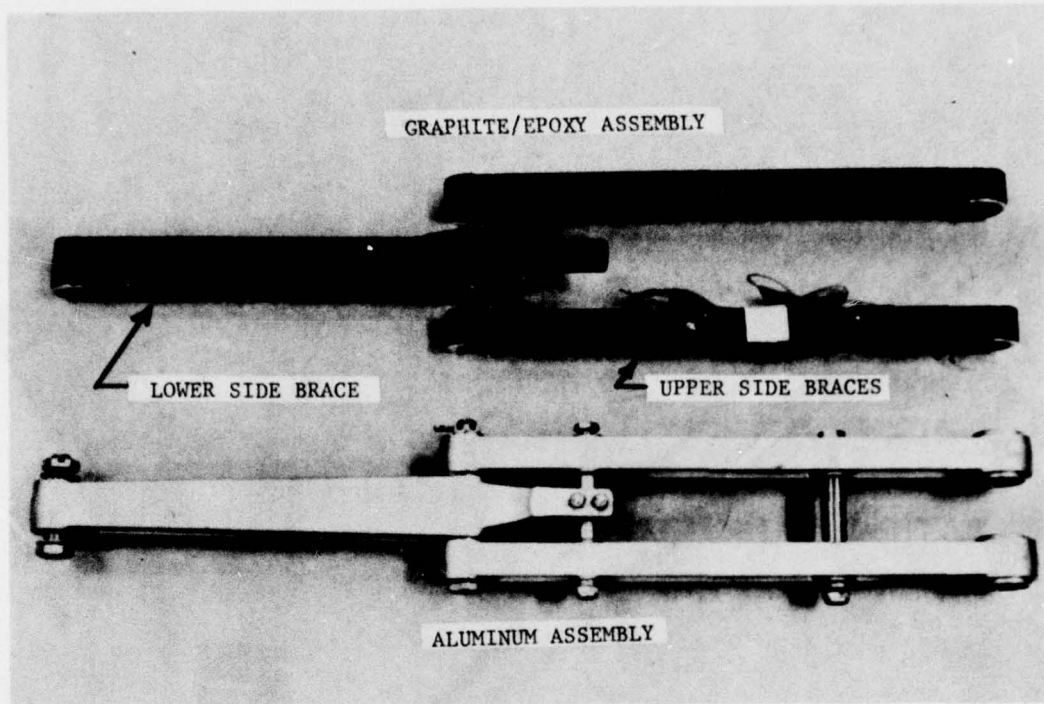

Figure 3. Graphite/Epoxy Side Brace and Its Metal Counterpart

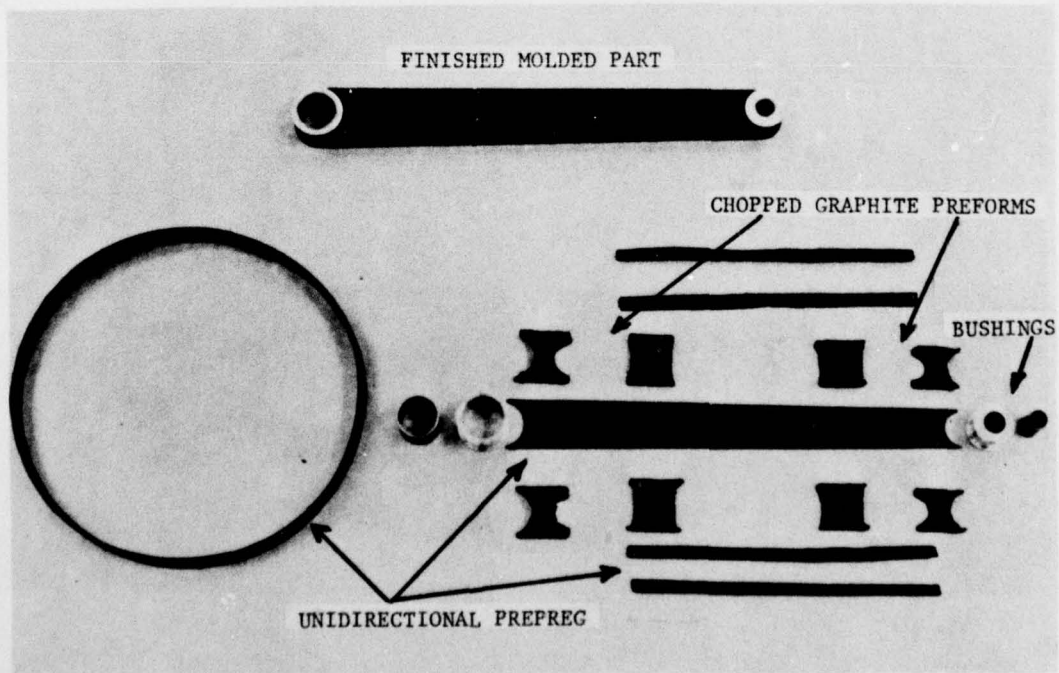

Figure 4. Upper Side Brace Components and the Finished Molded Part

SECTION III

FATIGUE TESTS

Figure 5 illustrates the test rig that was set up to conduct the fatigue test on a complete graphite epoxy side brace assembly. A rigid link was attached to the upper cross bolt of the assembly at a 45° angle to simulate the retraction linkage of the aircraft. At the time of the fatigue test, the amount of preload introduced into the assembly by this retraction link could not be determined. Thus, the linkage was adjusted so that the assembly was just "snug," in the unloaded position, with a nominal .06 inch overcenter dimension. The loads introduced into the

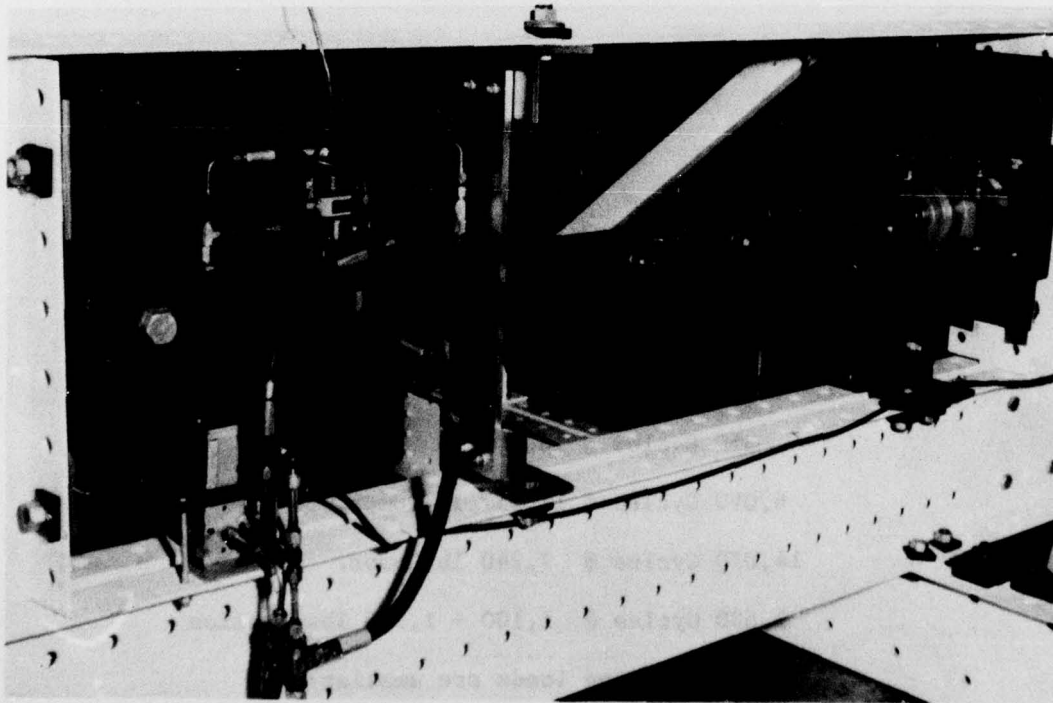

Figure 5. Fatigue Test of Complete Side Brace Assembly

test hardware were simple uniaxial tension and compression loads. The magnitude and schedule of the fatigue loads applied to the assembly are shown in Appendix A. This fatigue spectrum was generated for an A-37B production side brace by Cessna Aircraft Company. The flight loads are applied in a block-by-block manner. A summary of the the most important (highest) loads of this spectrum is shown in Table 1. A complete summary of the side brace assembly test results is shown in Table 2. Two different assemblies were tested. The lower member of the Serial Number 1 (S/N 1) assembly failed prematurely and was replaced by a substitute lower member labeled S/N 2. This assembly was then replaced by a completely new assembly labeled S/N 3. The number of lifetimes each part withstood and the pertinent comments about each part are also shown in Table 2.

TABLE 1
FATIGUE TEST LOADS ON GRAPHITE EPOXY SIDE BRACE

One Lifetime (24,080 Cycles)
350 Cycles @ 16,000 lb Compr.
6,090 Cycles @ 12,857 lb Compr.
14,070 Cycles @ 7,240 lb Compr.
1,680 Cycles @ 1,100 - 1,500 lbs Tension
(All remaining loads are smaller)

TABLE 2

SUMMARY OF GRAPHITE EPOXY SIDE BRACE ASSEMBLY TEST RESULTS

Hardware Serial No. (S/N)	Lifetimes* Obtained	Comments
S/N 1 Uppers S/N 1 Lower	1.9	Lower member failed at overcenter area (this lower member was initially a poor quality part with a known defect). The upper members were not damaged.
S/N 1 Uppers S/N 2 Lower	4.1 Total Lifetimes on Lower	The S/N 2 lower member had previously passed a static ultimate compression load of 25,000 lb (the part appeared to be undamaged).
	6.0 Total Lifetimes on Upper	- Both upper and lower members survived this test with no apparent damage.
S/N 1 Uppers S/N 2 Lower	One Cycle with 25% increased Compression Load	- Assembly failed catastrophically at approximately 19,500 lb at the first application of the higher loads.
S/N 3 Uppers S/N 3 Lower	4 Lifetimes	- Complete new assembly made from Hercules 2525AS material. - No apparent damage observed after 4 lifetimes were attained.
S/N 3 Uppers S/N 3 Lower	2 Add'l (Total of 6 Lifetimes)	- 25% increase in all loads in the fatigue spectrum. - The S/N 3 lower member failed in the overcenter area after approximately two lifetimes at the increased loads (a total of 6 lifetimes prior to failure).

FATIGUE TEST STOPPED

* 1 Lifetime = 24,080 Cycles = 7,000 flights

The rest of this chapter will give a description of the results shown in Table 2 along with the pertinent strain gage data and the conclusions to be drawn from the tests. At the time the fatigue test was started, the final design modifications had not been made to the lower member. Thus, the first two lower members tested (S/N 1 and 2) were not as representative of the final design as the S/N 3 lower member. In addition, the S/N 1 and S/N 2 lower members had areas around the "tang" that were highly suspect, from a structural standpoint, because of obvious fiber wrinkling. Design and fabrication changes were made to the S/N 3 lower member and the fiber wrinkling problems were corrected.

The S/N 1 lower member failed at 1.9 lifetimes into the fatigue test. Figures 6 and 7 illustrate the fatigue failure in the over-center "tang" area of the S/N 1 lower member. The S/N 1 upper members were not damaged, as shown in Figure 6, when the lower member failed, and thus the fatigue test was carried on with a substitute lower member (S/N 2). Figure 8 illustrates the fiber wrinkling which contributed to the fracture of the S/N 1 lower member (shown on the right). After the failure of the S/N 1 lower member, two additional strain gages (SG12 and SG13) were added to the overcenter "tang" area. Figure 9 illustrates the locations of all the strain gages on the side brace assembly. Strain gages SG12 and SG13 were located in the failure area of the S/N 1 lower member.

To determine the actual load on the "tang" of the lower graphite epoxy side brace, a calibration was made of two strain gages, SG11 and

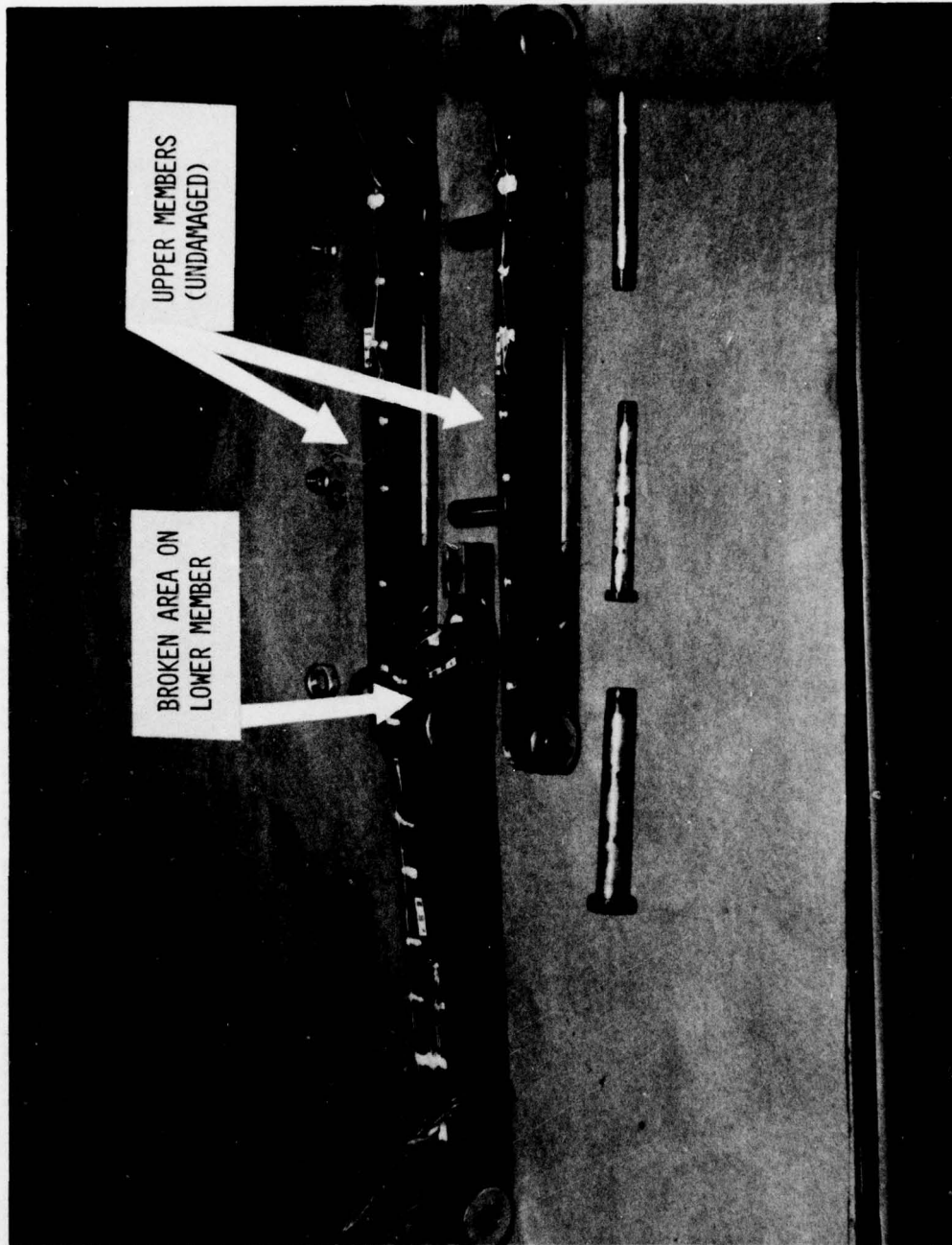

Figure 6. S/N 1 Upper and Lower Members After Failure of Lower Member at 1.9 Lifetimes

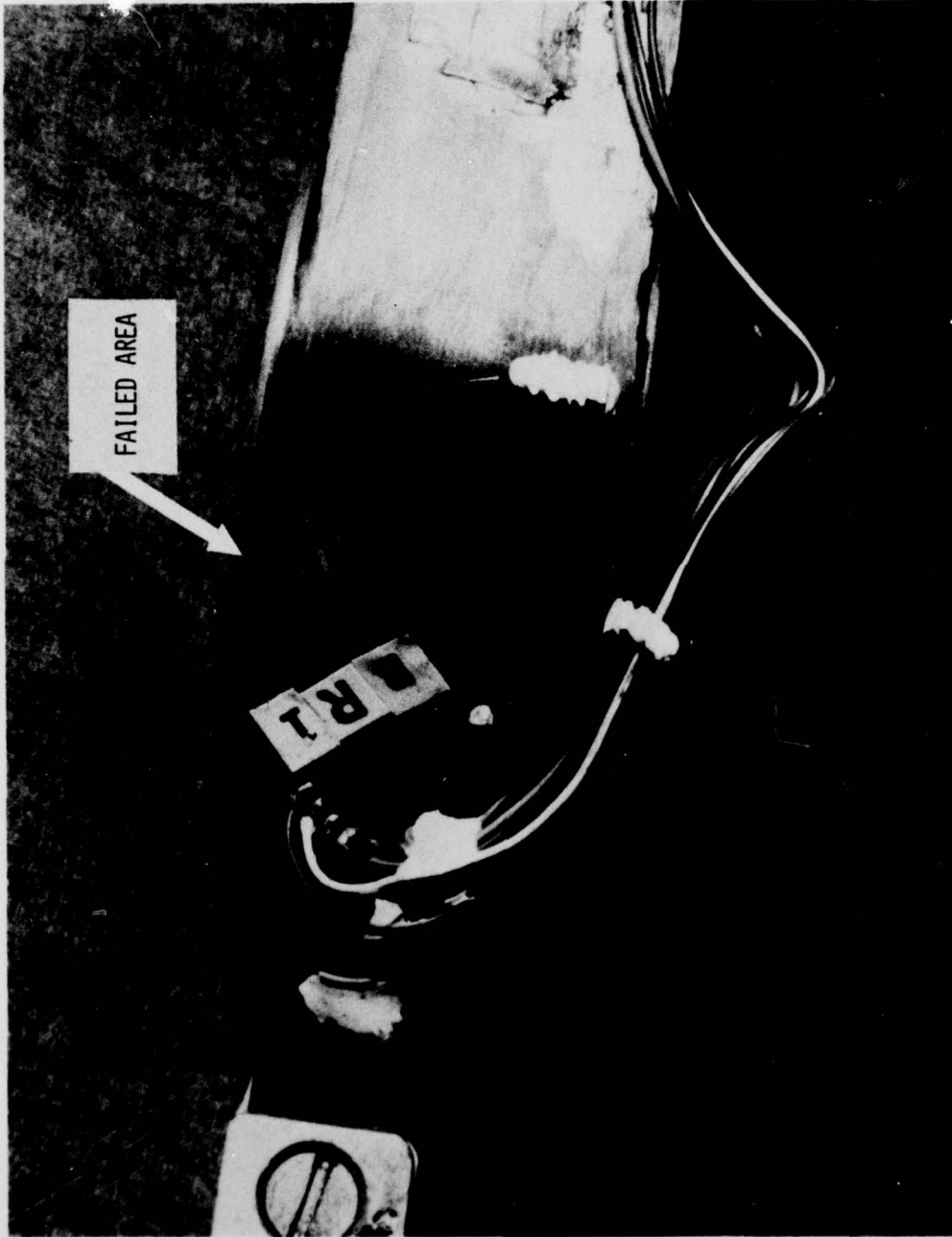

Figure 7. Fatigue Failure of S/N 1 Lower Member at 1.9 Lifetimes



Figure 8. Comparison Between Broken S/N 1 Lower Member and Substitute S/N 2 Lower Member After 4 Lifetimes

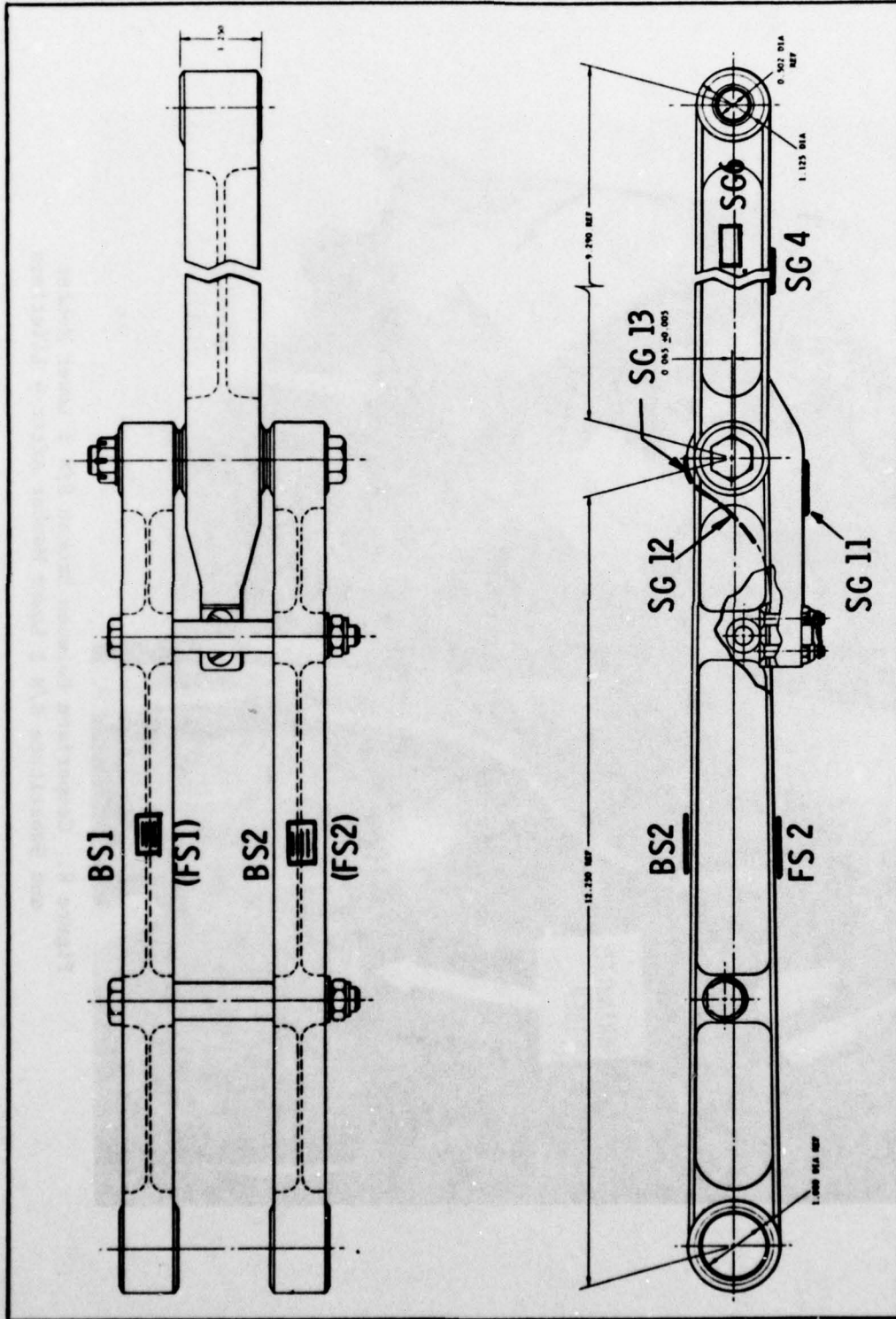

Figure 9. Strain Gage Number and Location

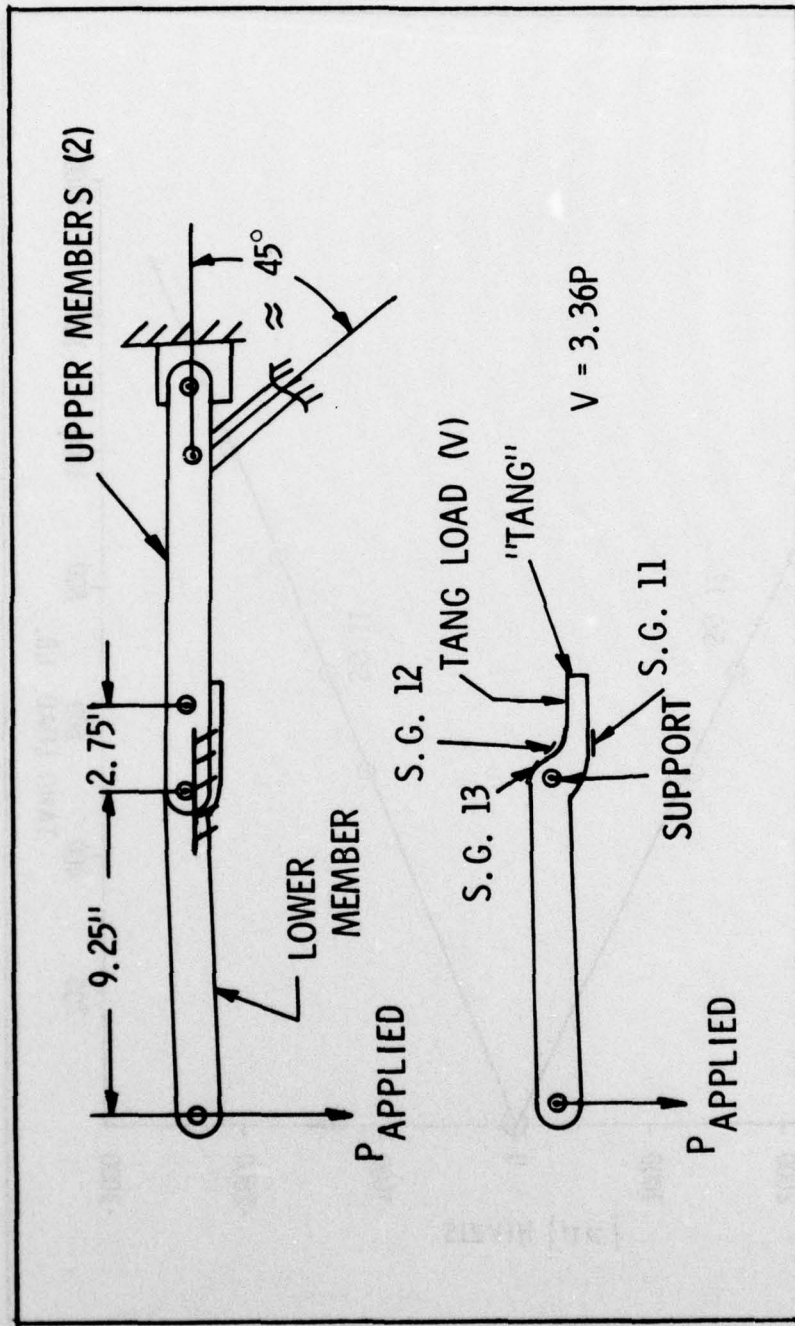

Figure 10. Tang Strain Gage Calibration

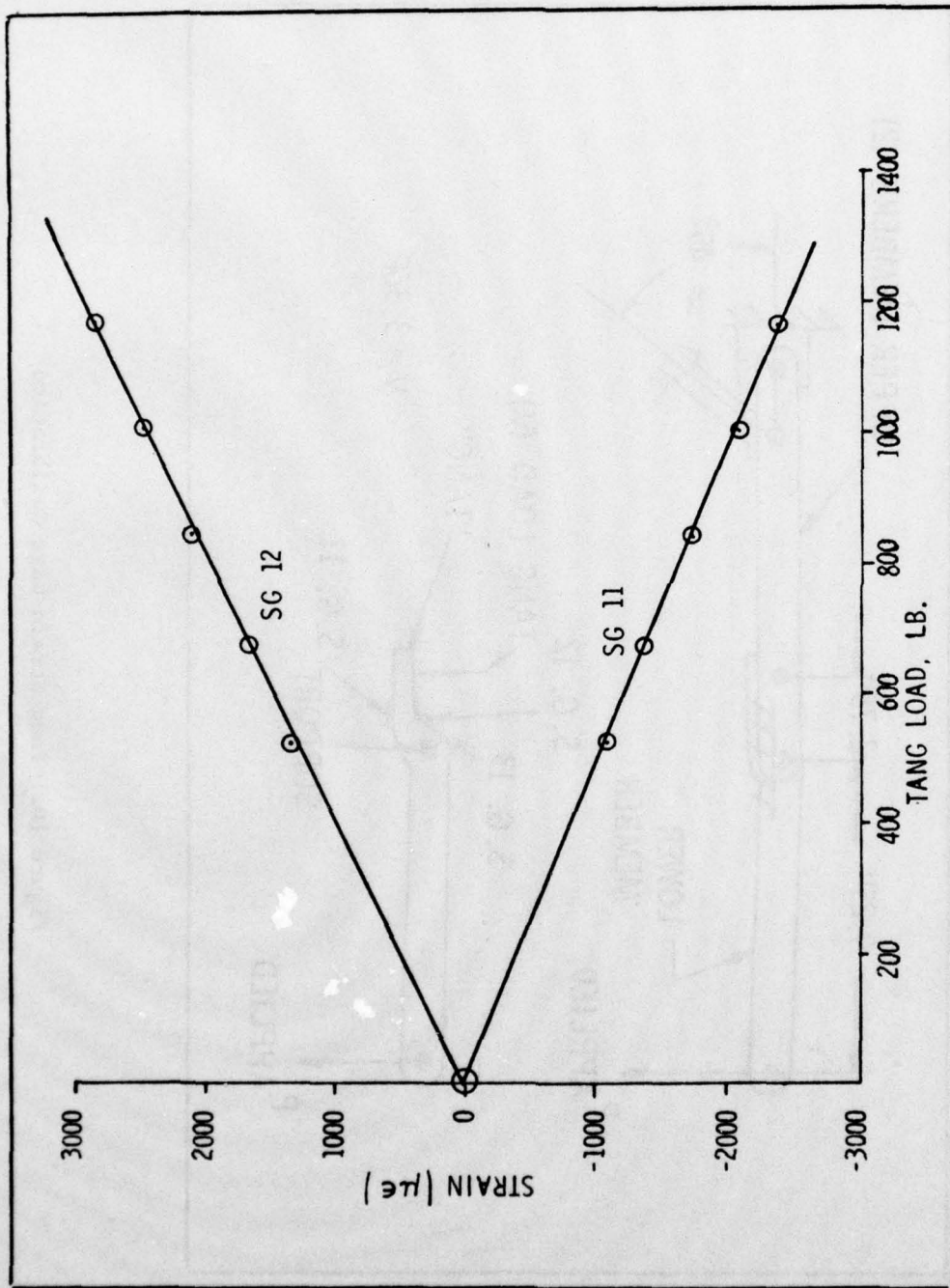

Figure 11. Calibration of SG11 and SG12

SG12 in the tang area. This calibration was done (see Figure 10) by applying a weight of up to 350 lbs to the end of the lower member of the assembly while supporting it on the opposite end. Figure 11 illustrates the strains for SG11 and SG12, plotted vs the computed "tang" load.

Figure 8 illustrates the broken S/N 1 lower member (on the right) vs a similarly wrinkled surface on the S/N 2 lower member. As mentioned above, these wrinkled areas made the parts highly suspect from the beginning. Even with the obvious fiber wrinkling, the S/N 2 lower member withstood over four (4) lifetimes of the fatigue spectrum (Table 2). After approximately four (4) lifetimes of the fatigue test, some small cracks became evident in the chopped fiber regions of the S/N 1 upper members. One of these cracks is shown in Figures 12 and 13. The crack shown in Figure 12 was found after four (4) lifetimes and Figure 13 shows the same crack after five (5) lifetimes. After attaining over four lifetimes on the S/N 2 lower member and six lifetimes on the S/N 1 upper members, it was decided to increase the fatigue loads by 25%. When this was done, the assembly failed catastrophically at approximately 20,000 lbs compression. Strain data were being taken at the time of the failure and strain gage No. 12 registered approximately 2500 $\mu\epsilon$. Figure 14 shows the failed assembly. Figures 15 and 16 show the failed lower and upper members, respectively. It is difficult to determine which part in the assembly failed first, but it is believed that the S/N 2 lower member failed first. After this failure, the lower member was further redesigned in the tang area.

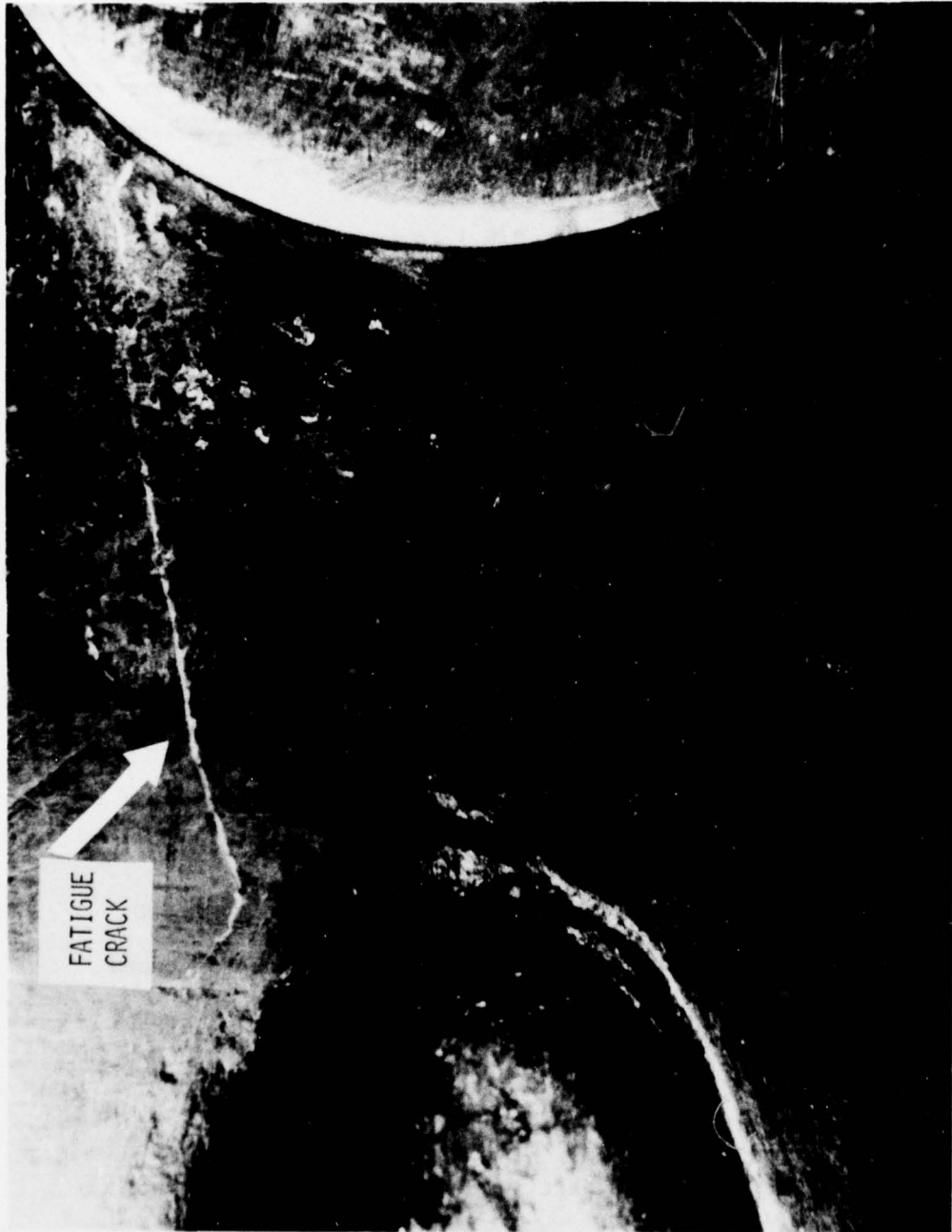

Figure 12. Fatigue Crack on S/N 1 Upper Member After 4 Lifetimes



Figure 13. Fatigue Crack on S/N 1 Upper Member After 5 Lifetimes

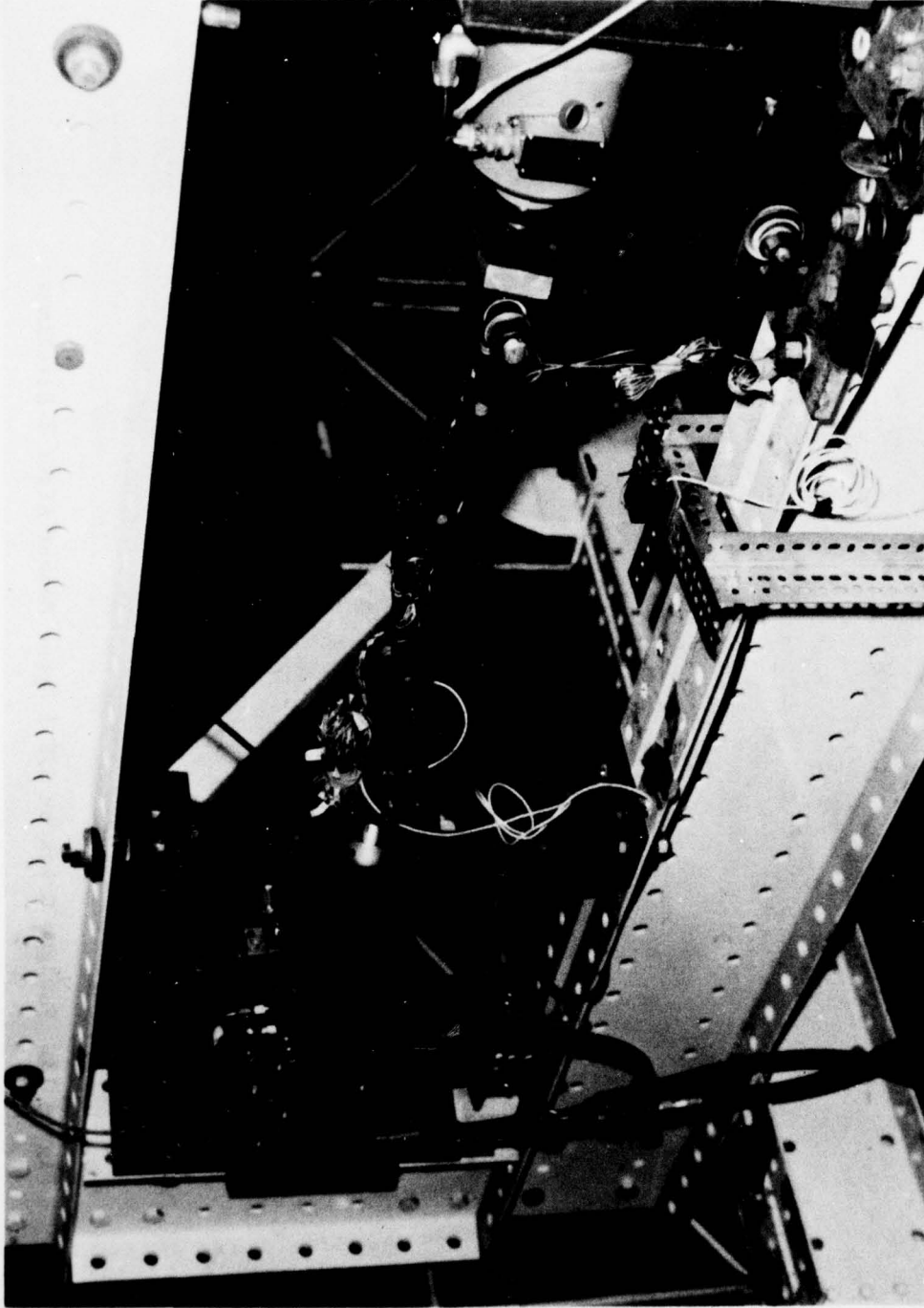

Figure 14. Failure of S/N 1 Uppers and S/N 2 Lowers After
25% Increased Load (6 Lifetimes on Uppers)

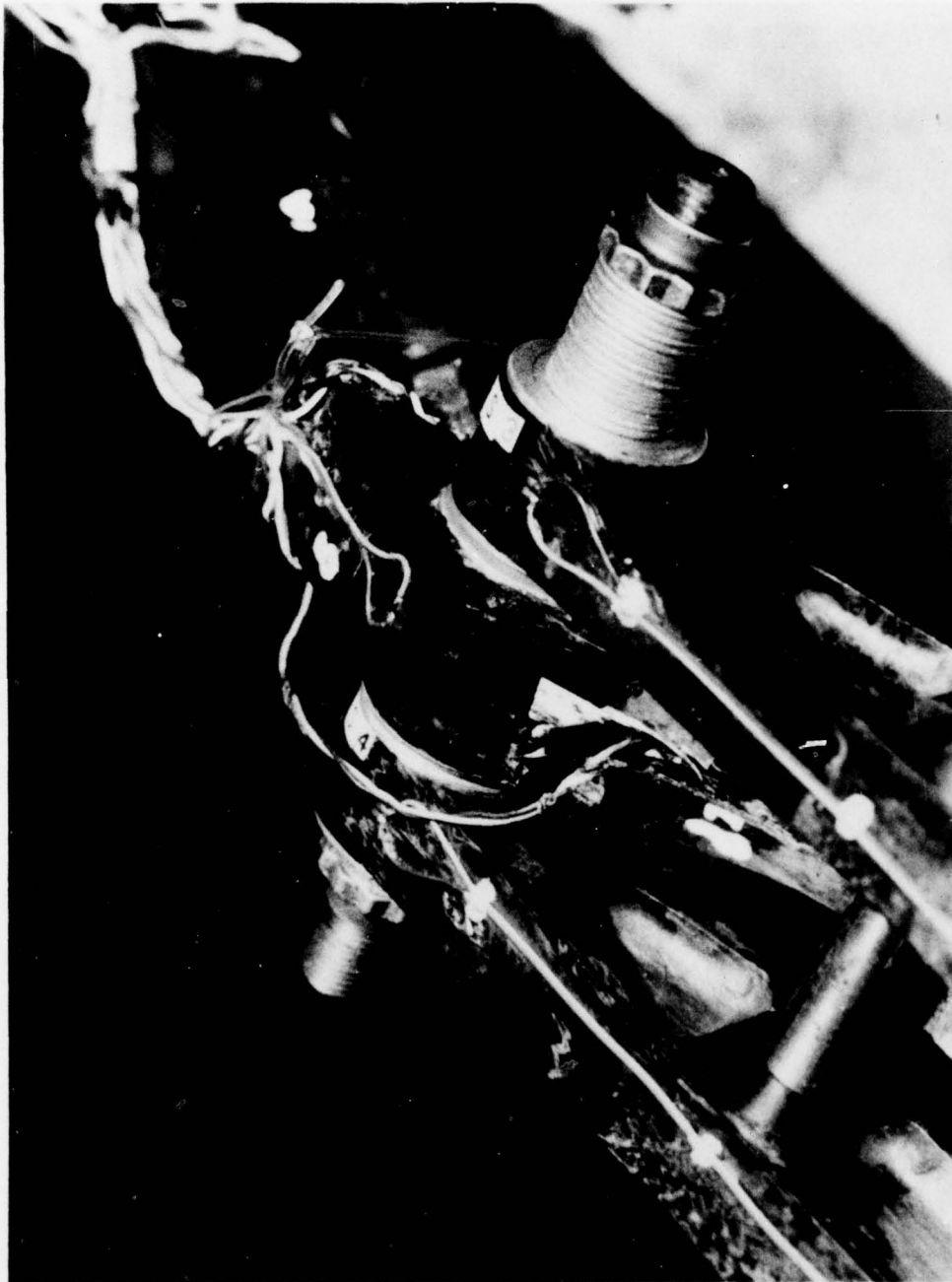

Figure 15. Failed S/N 2 Lower Member After 25% Increased
Load (4.1 Lifetimes on Lower Member)

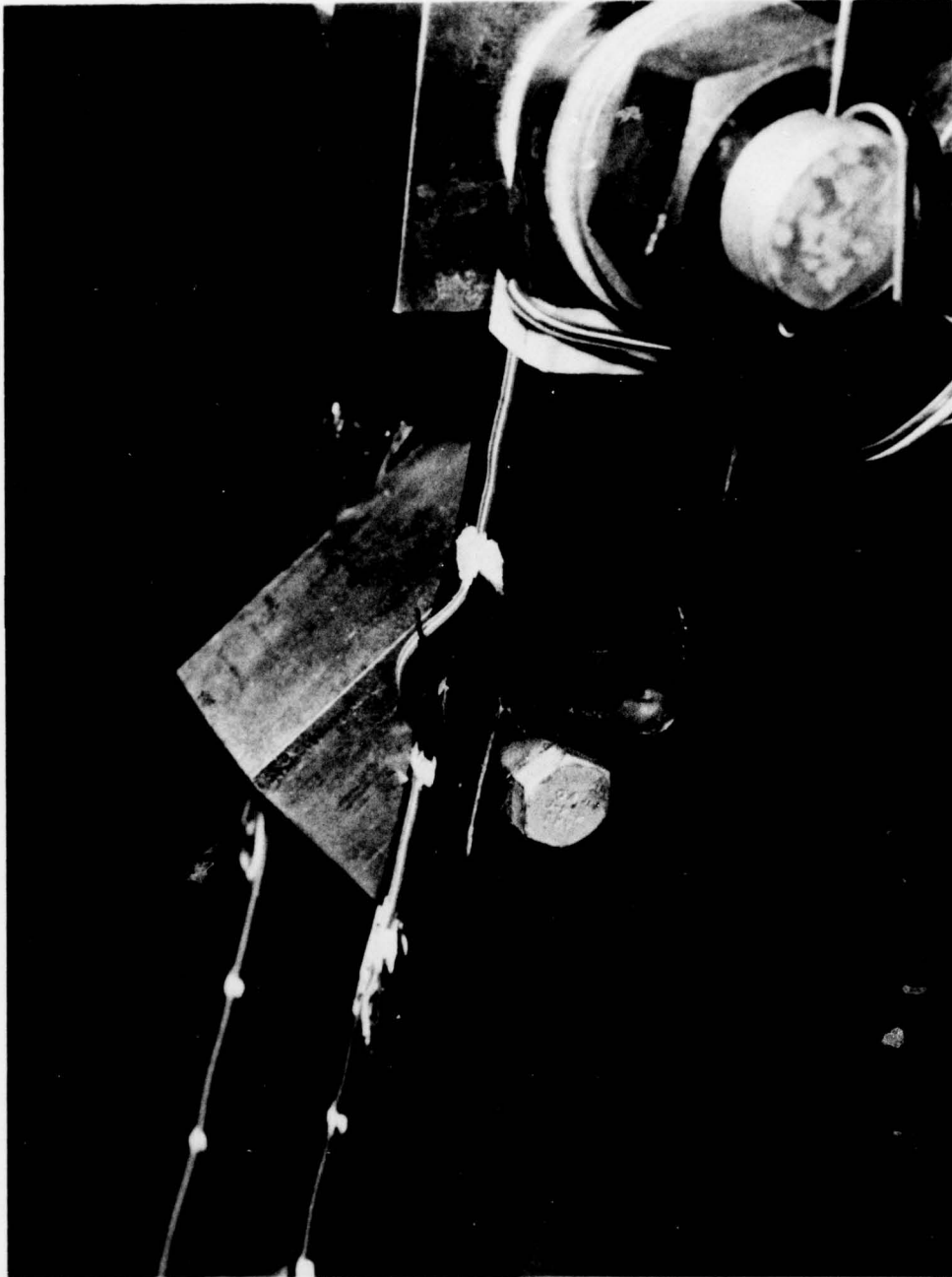

Figure 16. Failed S/N 1 Upper Members After 25%
Increased Load (6 Lifetimes on Upper Members)

In addition, new fabrication procedures were employed in order to eliminate the fiber wrinkling.

The next assembly received for testing contained all the design improvements in the overcenter region and it was made from a different material (Hercules 2525/AS) that had more strain tolerance. Strain gages were applied to the assembly as shown in Figure 9. Strain data were taken at one-half lifetime increments throughout the fatigue test. Figure 17 illustrates a typical set of strain data taken after two lifetimes. The assembly is cycled through the peak load of the fatigue test while data are taken. Notice that the strains on SG12 are over 2000 μ . After four lifetimes of the normal fatigue cycling, no evidence was seen of any cracks in the hardware. At that point, the fatigue loads were again increased by 25%. Figure 18 illustrates the maximum typical strains which occurred. Notice that the strains on SG12 are considerably higher, at the same load level, than previously seen. Since the hardware was periodically disassembled for inspection, the changes in strain levels must be due to a different alignment in the test fixture. The S/N 3 assembly withstood approximately two lifetimes under the 25% increased loads. At about two lifetimes, the S/N 3 lower member failed at the tang area. This failure is shown in Figure 19. Even with this failure, the design of the S/N 3 hardware was judged to be adequate because the hardware had withstood four (4) lifetimes of normal fatigue loads and two lifetimes of 25% increased fatigue loads. The practice of increasing the fatigue loads above their normally designated values is open to debate. In this case, it is felt that an

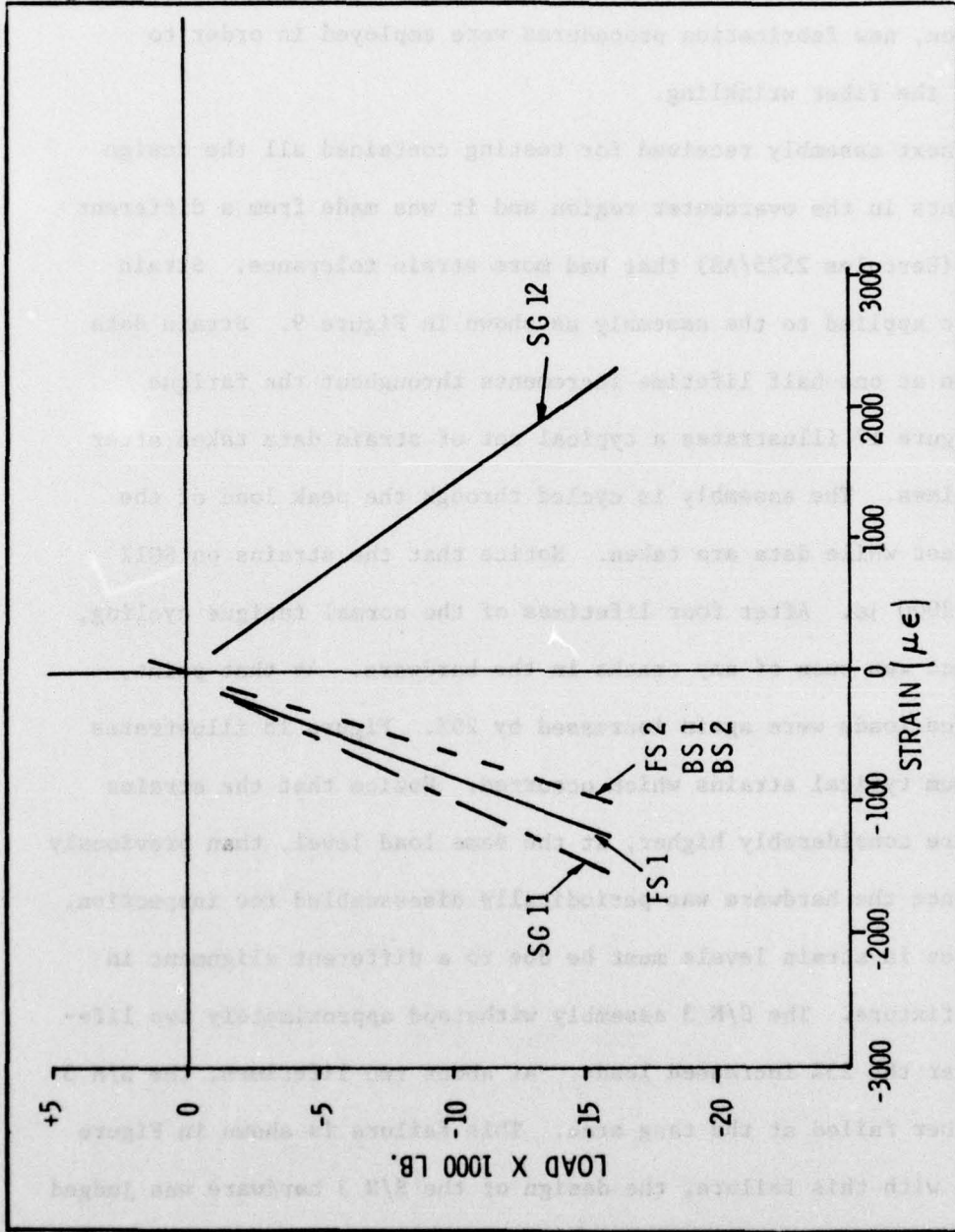

Figure 17. Typical Strain Data from the S/N 3 Assembly After 2 Lifetimes

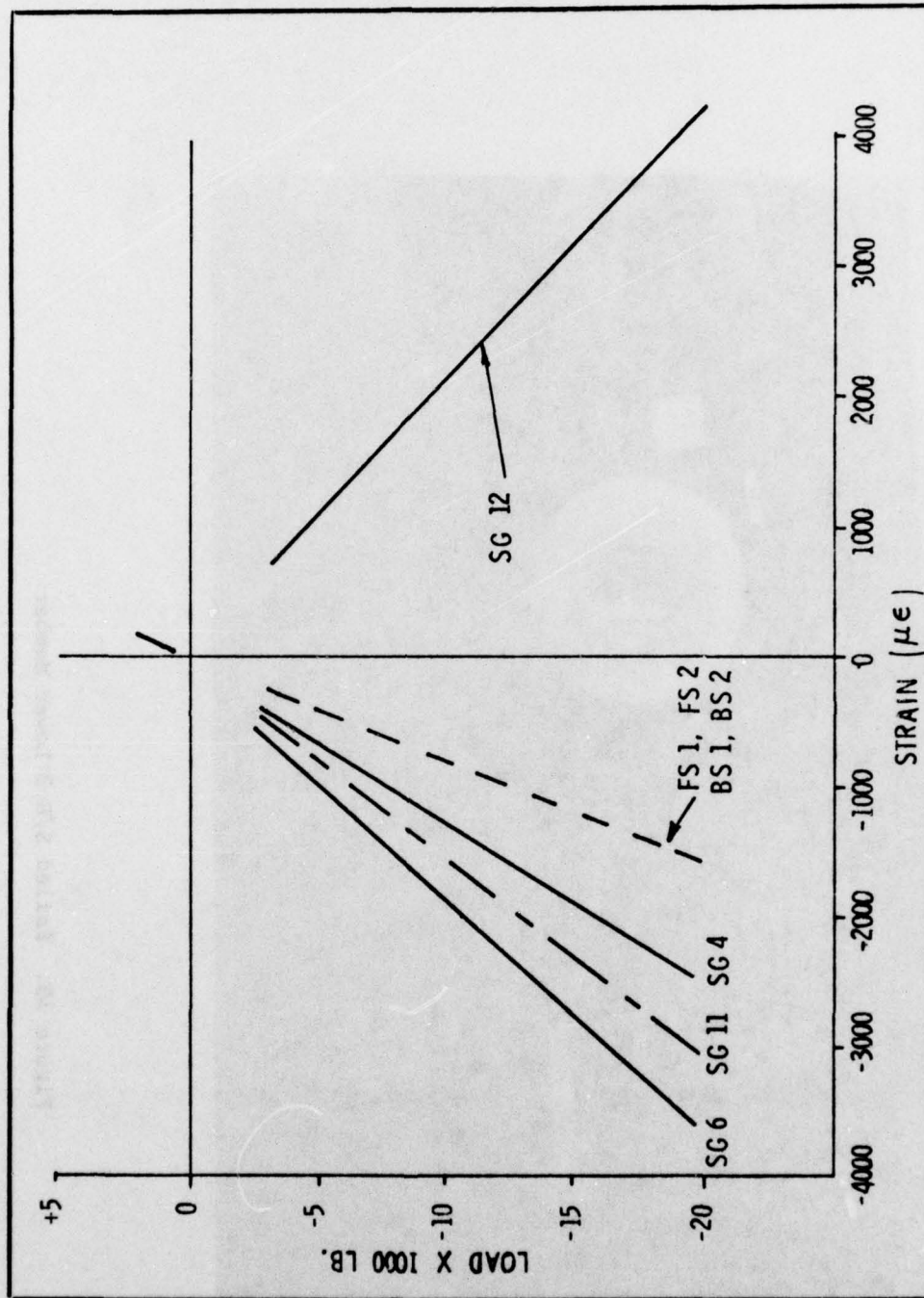

Figure 18. Typical Strain Data for the S/N 3 Assembly Subjected to a 25% Increase in Fatigue Loads



Figure 19. Failed S/N 3 Lower Member

eventual failure would first occur in the overcenter area of the lower member. However, the question that obviously was not answered by these tests was how much longer the part would have lasted at the normal fatigue loads.

The later sections of this report will compare the actual flight test data to the fatigue test data. It will be shown that although the fatigue test data is not completely representative of the flight test spectrum, the fatigue test was severe enough to be of great value when making judgments about the flight worthiness of the flight test hardware.

SECTION IV

ENVIRONMENTAL TESTS

A major concern at the time of the fatigue tests was how the graphite epoxy material would hold up in the service environment. The intent of the environmental test program was to determine the ability of graphite epoxy composite landing gear hardware to hold up under prolonged operational conditions. Specifically, the tests determined whether or not strength degradation occurred as a result of exposure to moisture, heat, or any other environment. The tests were designed to simulate accelerated ageing and worst "real-life" conditions in order to establish confidence in hardware fabricated from graphite epoxy composite (Reference 2).

Thirty-three identical composite upper side brace members were subjected to a variety of prolonged environmental tests and then loaded in compression until failure to check for degradation in strength. Compressive testing was done because the composite part is highly dependent upon the matrix in compression, and it was predicted that the matrix would be most affected by moisture. It is impossible to construct laminated coupons with various plies to fully duplicate a structural part with chopped and continuous fibers. Usual material testing involves breaking of small "coupons" or samples of the material. There is often doubt, however, as to how valid these data will be when the material is laid up in a large, complex, and highly loaded structure. It was for these reasons that full scale hardware testing was chosen over coupon testing for this program.

Environmental tests included exposure to 95% relative humidity at 120° - 200°F for nine months; soaking in JP4, anti-icing fluid, hydraulic oil, and trichloroethylene solvent; exposure to ultra-violet radiation and high humidity; natural weathering; abuse with hand tools; six lifetimes of fatigue loads; and the "Rangoon cycle" involving cyclic exposure to temperature extremes and high humidity.

The only factors having major influence on ultimate strength were moisture and temperature extremes. Absorbed moisture had no effect on room temperature and low temperature static strength. The worst degradation in strength occurred as a result of combined high moisture retention and high temperature. Even with this degradation, all the test hardware (even the defective parts) met or exceeded their design ultimate loads. There was every reason to believe that this conservatively designed composite landing gear hardware would hold up under all operational environments.

An interesting and beneficial sidelight was the fact that ultrasonics and radiographic inspection accurately predicted detrimental defects in two of the parts.

Non-destructive inspection (NDI) consisted of visual inspection, recording of dimensions, radiographic inspection, ultrasonic inspection, and an electrical resistance check. The most valuable information regarding detrimental flaws came from the radiographic and ultrasonic tests. X-ray exposures revealed areas lacking fiber (fiber wash or voids) near both bushings of SN6, and a similar area near the large bushing of SN14 (Figure 20). These were the two test items which

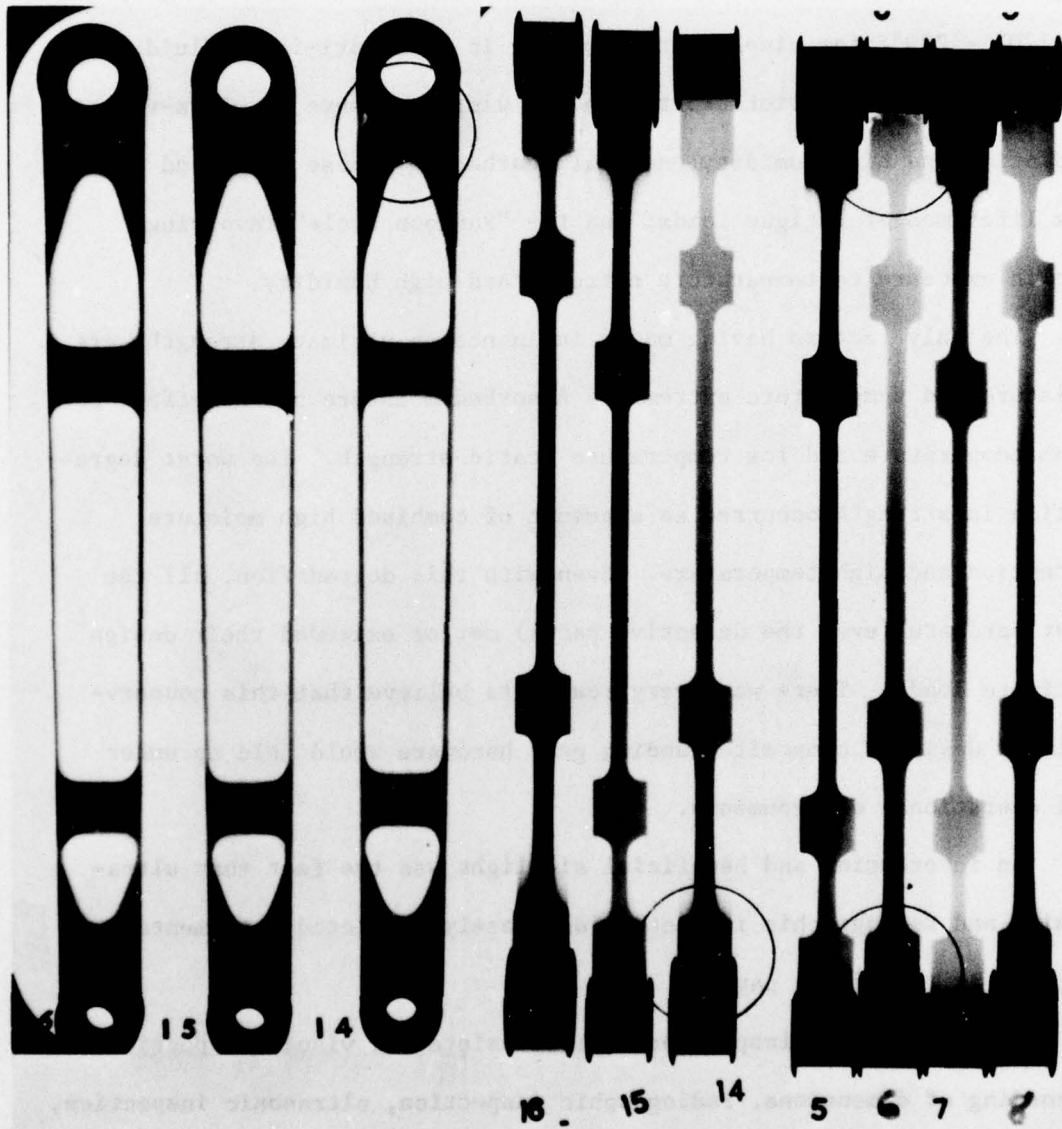

Figure 20. X-Rays Showing Fiber Wash and Voids (Light Areas)
Near Bushing of SN6 and SN14

were considered to have failed prematurely in the static compression test. They did not fail in the characteristic way at the small bushing, but rather at the large bushing in both cases.

Through-transmission ultrasonic C-scans revealed several areas that remained opaque to the sound beam even with the maximum instrument gain. Most notable of these, probably containing delaminations, were the areas adjacent to the bushings of SN6 (Figure 21). This again is one of the two parts which failed below expectations.

These parts and several others were eventually sectioned to determine what made them opaque to ultrasonics and transparent to x-rays, and possibly determine why they failed as they did. After sectioning, potting and polishing the specimens, definite voids and lack of fibers near the bushings of the defective side braces became evident (Figure 22). These are almost definitely what caused the parts to fail prematurely. This unexpected dividend from the environmental test program gave a good data base upon which to judge the flight test hardware and its NDI results.

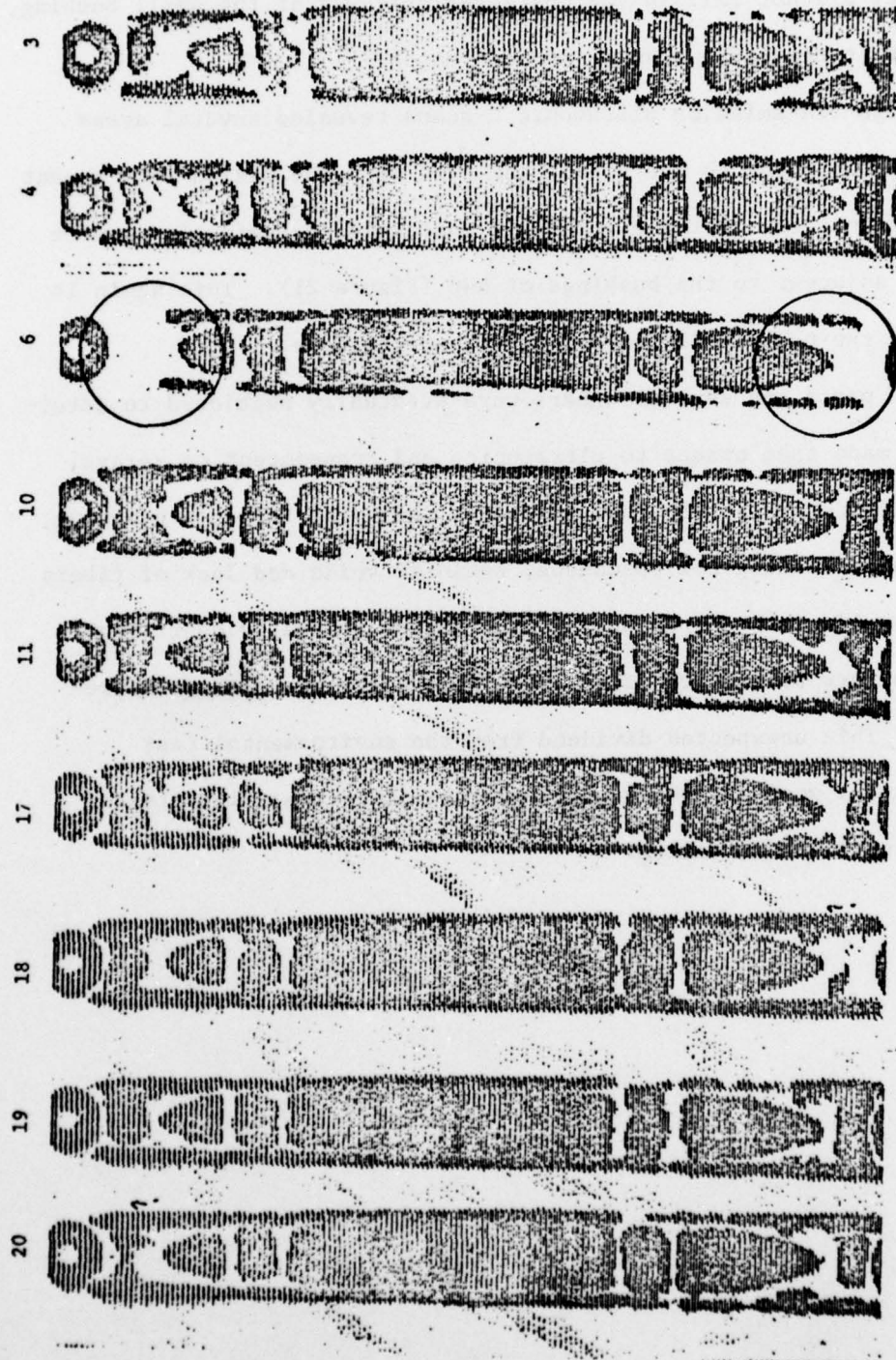

Figure 21. Ultrasonic C-Scans Showing Possible Delaminations (Lights Areas) Near Ends of SN6

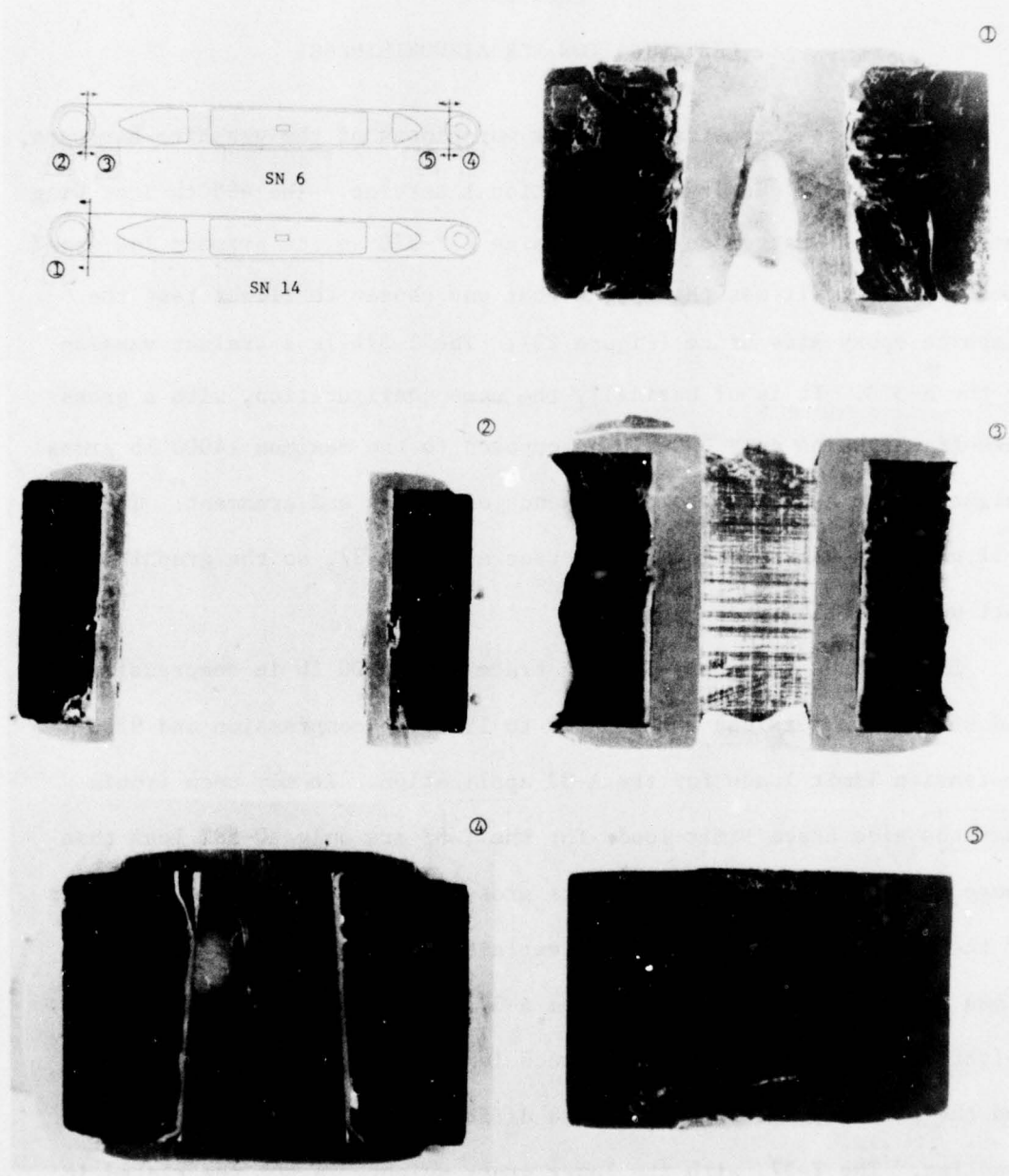

Figure 22. Sectioned Views of Defective Side Braces Showing Voids, Lack of Fiber, and Some Fracture Damage from Static Tests

SECTION V
CERTIFICATION FOR AIRWORTHINESS

In order to demonstrate the air worthiness of the graphite hardware, it was decided to put it into operational service. The 4950th Test Wing based at Wright-Patterson AFB maintains a T-37B as its primary low speed pace aircraft. It was this plane that was chosen to flight test the graphite epoxy side brace (Figure 23). The T-37B is a trainer version of the A-37B. It is of basically the same configuration, with a gross takeoff weight of only 6600 lb as opposed to the maximum 14000 lb gross weight of the A-37, due to the absence of stores and armament. The T-37 uses the same aluminum side brace as the A-37, so the graphite part was directly interchangeable.

Limit loads for the T-37 side brace are 15900 lb in compression and 6600 lb in tension, as compared to 19900 lb compression and 9200 lb tension limit loads for the A-37 application. It may seem ironic that the side brace limit loads for the T-37 are only 20-28% less than those for the A-37, even though its gross weight is less than half that of the A-37. This anomaly can be explained, however, by the restrictions imposed upon operation of the A-37. Because of its heavier weight, the A-37 is limited to a much lower sink rate during landing and the pilot is not allowed to use differential braking during ground handling. The T-37, with its lower gross weight, is not restricted in operation and its side braces must therefore react proportionately higher loads. The graphite epoxy side brace, because it was designed for the higher A-37 operating loads, was considered quite adequate for flight test on the T-37 at Wright-Patterson Air Force Base.

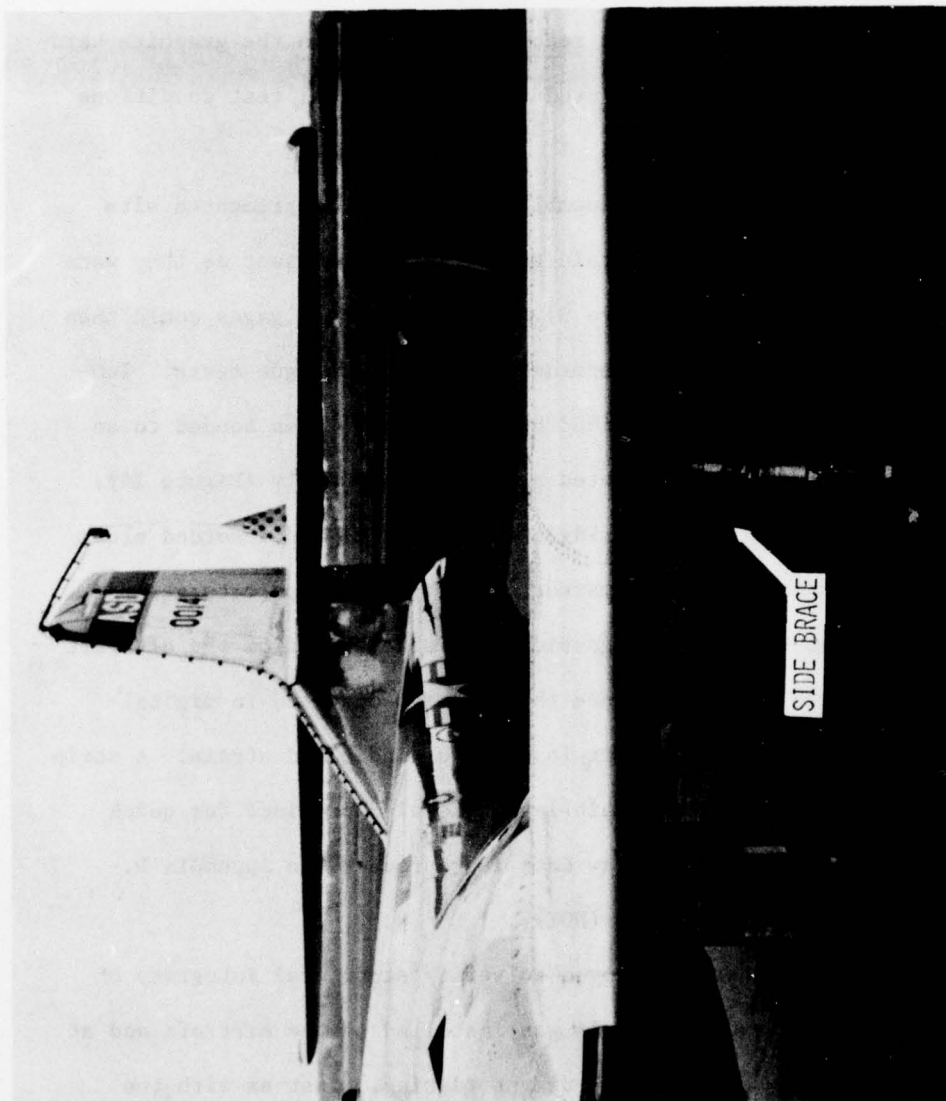

Figure 23. Side Brace Installed on T-37, Ready for Flight Test

A. INSTRUMENTATION

In order to obtain as much useful information as possible from the flight tests, it was decided to record strain data on the graphite hardware. This data would also be used to monitor actual test conditions and hardware performance.

Two graphite side brace assemblies were each instrumented with eight single element bonded strain gages, positioned just as they were during the fatigue tests (Figure 9). Data from these gages could then be compared directly to data recorded during the fatigue tests. Temperature compensation was provided by eight dummy gages bonded to an unloaded piece of graphite mounted next to the assembly (Figure 24). Output from the eight strain bridges was amplified and recorded along with a pilot-controlled event marker on a magnetic tape recorder. Following flight tests, the magnetic tape is removed from the aircraft and taken to data reduction where the data is converted to digital information and printed on paper in terms of indicated strain. A strip chart indicating the eight strain levels is also provided for quick reference. A sample of this raw data is reproduced in Appendix D.

B. NONDESTRUCTIVE INSPECTION (NDI)

Several methods were employed to verify structural integrity of the graphite side brace before it was installed on the aircraft and at intervals since the start of its flight testing. Just as with the environmental test pieces, ultrasonics and radiographics were initially used to check for voids, delaminations, cracks, or disbonds. Nothing considered detrimental to strength was uncovered with these methods.

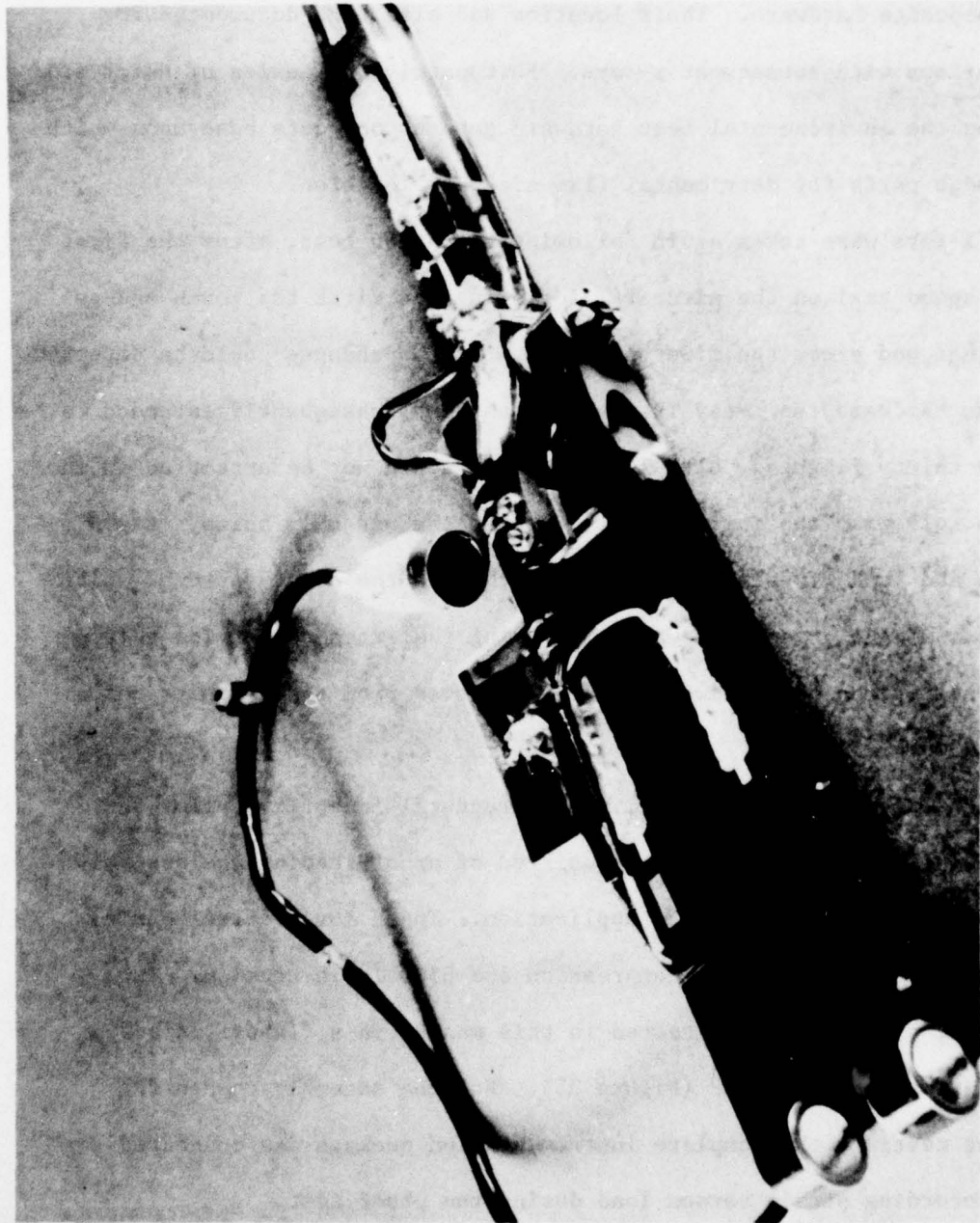

Figure 24. Flight Test Side Brace With Strain Gages and Wiring

Some artifacts and anomalies were noted, as they are with every piece of composite hardware. Their location and size were documented for comparison with subsequent x-rays. Fortunately the series of NDI tests run on the environmental test hardware gave a good data base upon which to judge parts for detrimental flaw size and location.

X-rays were taken again following the proof test, after the first high speed taxi on the aircraft, following the first ten touch-and-go landings and after the first nine flights. No changes could be detected in the hardware, so x-ray inspection has been subsequently extended to every thirty flights. Ultrasonic C-scans could not be attempted on the parts following the initial test, because the assembly bolts, strain gages and lead wires interfered too much with the sound pattern. Ultrasonics will be attempted again, following the extended service test, when all extraneous hardware has been removed from the graphite parts.

C. PROOF TESTS

The final test for determining structural integrity, prior to installation on the aircraft, consisted of proof-loading the assembly to 80% of limit for the T-37 application. These loads correspond to approximately 13000 lb in compression and 5500 lb in tension. Two complete assemblies were tested in this manner in a fixture attached to a Baldwin load tester (Figure 25). For the assembly chosen for flight testing, the complete instrumentation package was connected and recording strain versus load during the proof test.

As it turned out, the original proof test fixture had not simulated the initial side load provided by the aircraft's side brace

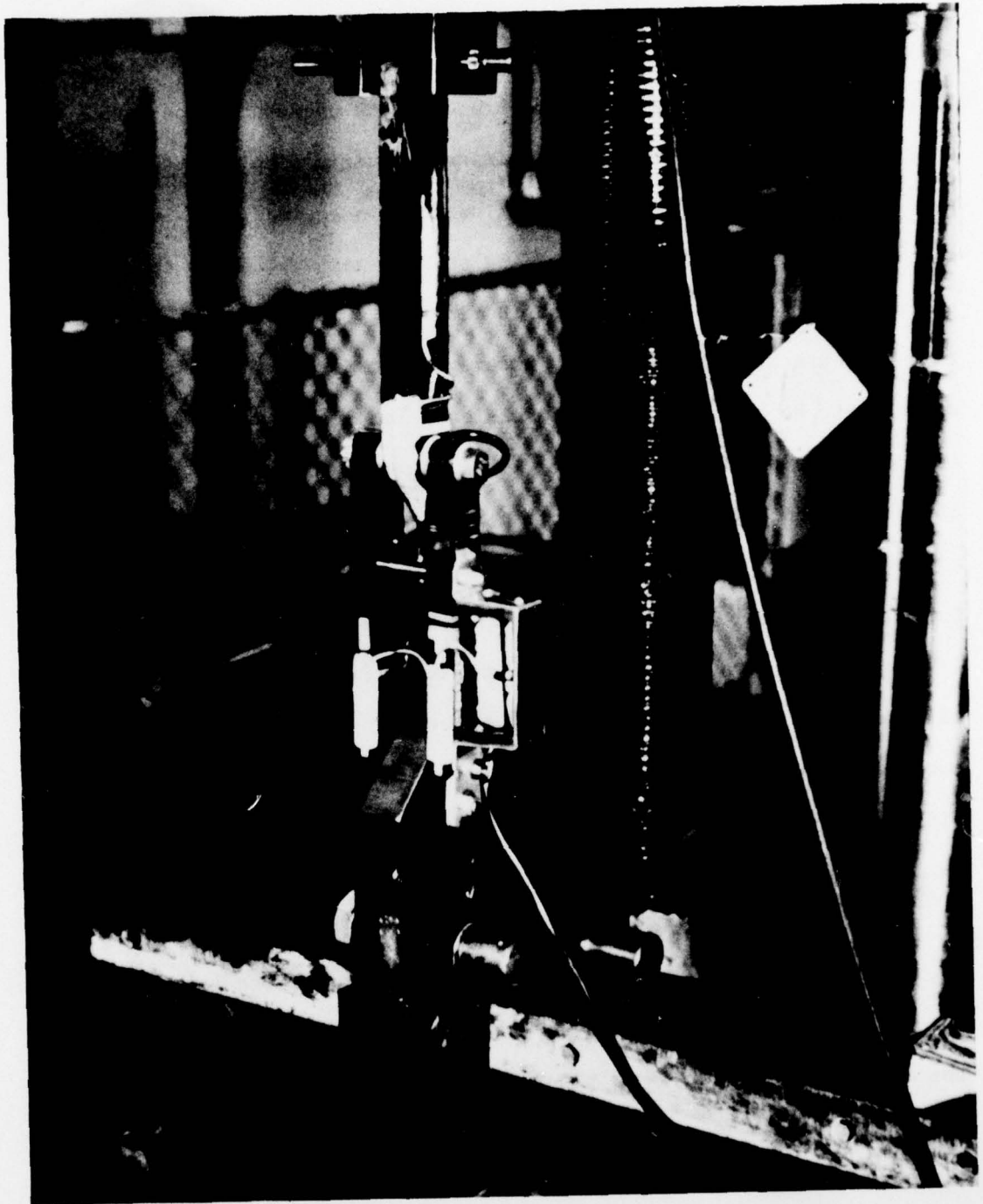

Figure 25. Side Brace During Proof Test

locking mechanism. This load is introduced through the upper cross bolt and positively locks the side brace in its overcenter position, once the gear is down and locked. It was a fairly simple matter to modify the proof test fixture to introduce this preload. An initial side load that gave a 1000 $\mu\epsilon$ reading at SG12 was applied to the side brace for subsequent proof tests. During the proof test of the flight test side brace, the load tester became uncontrolled and caused the assembly to be overloaded in compression. The lower side brace failed in the tang area at a compressive load estimated to be in excess of 30,000 lb. Unfortunately the strain recorder was not operating at the time, so there was no record of maximum strains achieved before failure. This unintentional destructive test did, however, corroborate the area likely to fail first and the mode of failure (Figure 26). Following this setback, the second fully instrumented graphite side brace was successfully proof tested, generating more realistic strain values with the initial side load. A plot of strain versus load is presented in Appendix B.

D. TAXI, TURNS

The graphite side brace and its instrumentation were installed in the T-37 while it was elevated on jacks. The gear was cycled up into the wing several times under power and manually to verify its operation. Everything functioned properly mechanically, but two minor problems with the strain gage instrumentation developed. One was that at least four of the strain bridges were no longer balanced, but had exhibited some drift over a period of time. There was no provision for rebalancing

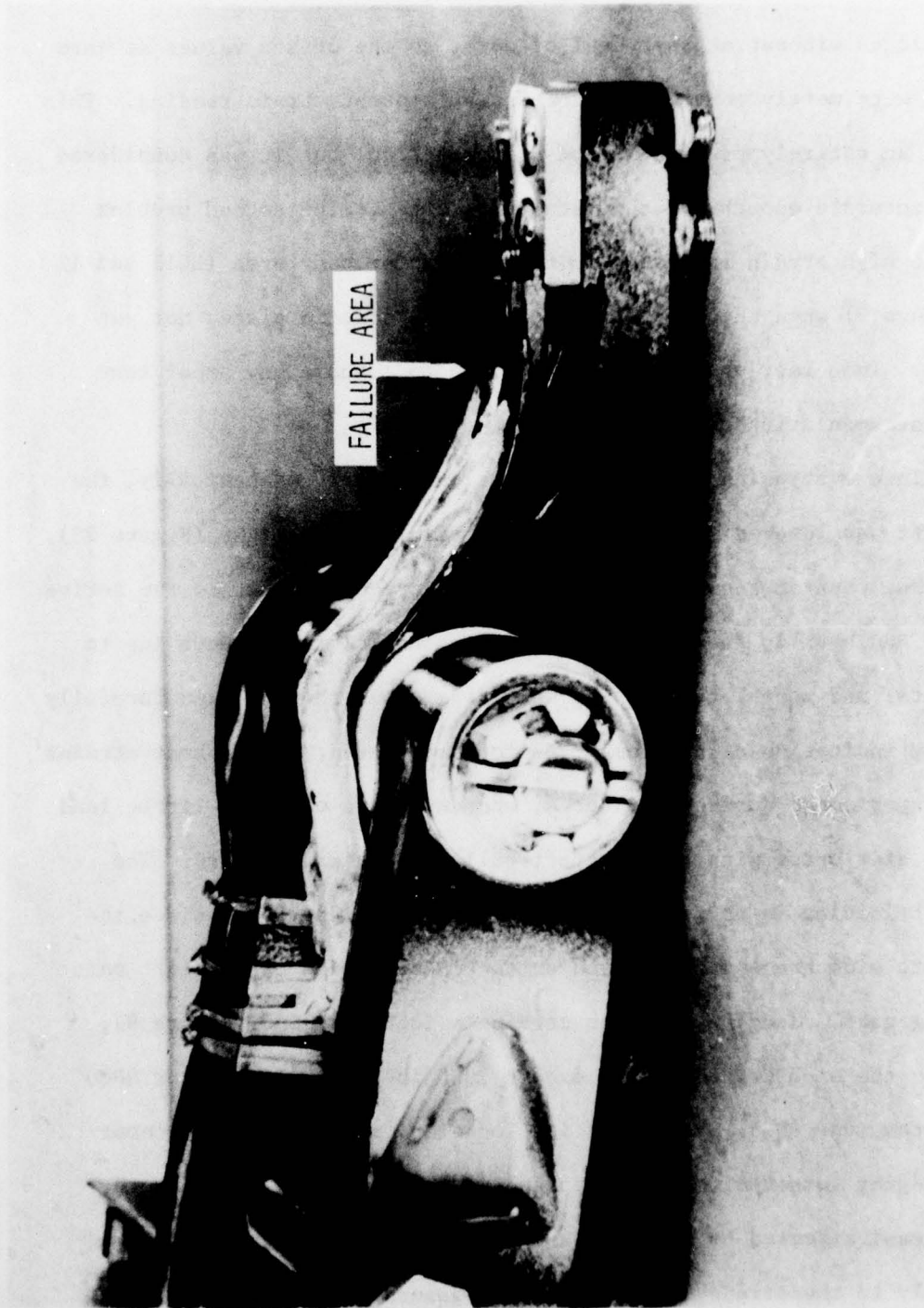

Figure 26. Failed Lower Member of Side Brace, Result of Overload During Proof Test

the bridges without a great deal of work, so the offset values at zero strain were merely subtracted from any subsequent strain reading. This is not an entirely precise method of correction, but it was considered quite accurate enough for the data being taken. The second problem was the high strain indicated in the overcenter tang area (SG11 and 12 in Figure 9) when the gear was merely locked down in place, not yet loaded. This fact was eventually to lead to a whole new proof test and instrumentation calibration.

Since everything appeared to function properly mechanically, the aircraft was lowered from the jacks and readied for flight (Figure 23). The first test of the side brace was a low speed taxi out to the active runway and back to the parking ramp, using normal taxi speeds (up to 30 knots) and normal turns. The strain data was then checked carefully for any indication of problems. As to be expected, the highest strains were experienced during hard turns, whereas there was very little load on the side brace with the aircraft rolling straight forward. The highest loading in compression occurred during right turns since the graphite side brace was employed on the inboard side of the left main landing gear. Judging from the strain indicated by SG6 (Figure 9), load on the side brace did not exceed 1800 lb in compression or 3000 lb in tension. SG6, because of its location, is the best indicator for judging longitudinal load applied to the side brace. It is the gage least affected by bending, and its output can be compared directly to the strain versus load plot generated during the proof test for an indication of load magnitude. None of the gages showed

areas of excessive strain, with the exceptions of SG11 and SG12. These showed that the tang area was being loaded more highly than it had been during proof tests, which was definite cause for concern. The maximum strain seen by SG12 (approximately 1500 $\mu\epsilon$ tension) was not the level seen during the fatigue test (over 4000 $\mu\epsilon$), but definitely more than the 900 $\mu\epsilon$ generated during the proof test at 80% of limit load in compression (SG12 goes into tension, being on the bottom of the tang, when the side brace assembly is compressed). It had already been agreed, however, that whenever any strain value exceeded that generated during the proof test, the flight test would be halted. For this reason, the side brace and its instrumentation were removed from the aircraft and returned to the lab for the second, more realistic proof test.

The graphite side brace and instrumentation were again installed in the T-37, cycled on jacks, and put through the low speed taxi maneuver. Strain values similar to those recorded during the first low speed taxi were observed. These levels gave no cause for concern when compared to the recent proof test. Estimated loads on the side brace ranged from 1700 lb tension to 4300 lb compression. The next step was a high speed (70 knot) taxi the length of the runway, plus typical turning maneuvers. This run surprisingly gave even lower strain values. Loads ranged from only 1700 lb tension to 2200 lb compression. The difference was accounted for in the way different pilots handle the plane during ground maneuvering. The side brace was again removed and x-rayed. No changes were detected in the structure, so it was prepared for its first flight.

E. INITIAL FLIGHT TESTING, LANDINGS

The first normal takeoff and landing on the graphite side brace was uneventful. The highest loads recorded were in the range of 1700 lb tension to 3300 lb compression - less than those experienced during the low speed taxi. These peaks occurred not upon lift off or touchdown, but during ground handling. Once these strain data were evaluated, the side brace was considered ready for its most severe test. This consisted of a series of ten touch-and-go landings, with four of these landings simulating poor crosswind (drift) landings. The four drift landings, two with slight right crab and two with slight left crab at touchdown, turned out to be the worst conditions applied to the side brace before or since that time. Loads were estimated to range from 2800 lb tension to 5000 lb compression. Strain values rose to peaks of 1900 $\mu\epsilon$ at SG12, under the tang. These values are still low compared to design conditions or the proof test conditions. A summary of highest loads and strains experienced during flight tests, fatigue, and proof tests is presented in Appendix C. A sample of the raw strain data taken during the touch-and-goes is reproduced in Appendix D. Another set of x-rays was made to the graphite side brace, but no changes could be detected. Based on these considerations, the side brace was judged to be flightworthy (Figure 27).

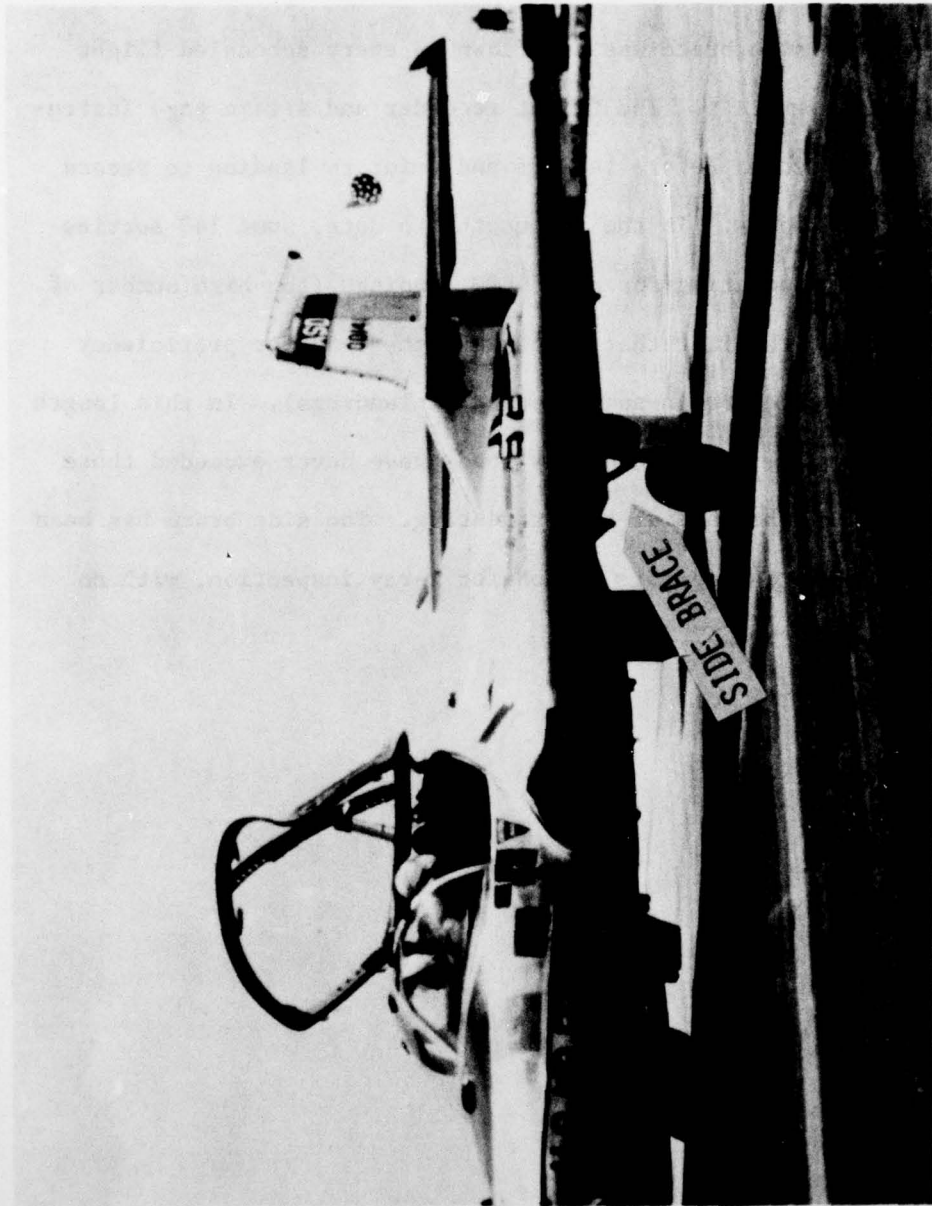

Figure 27. Graphite Side Brace on T-37 During Service Test

SECTION VI

SERVICE TEST

The graphite side brace was now flown on every scheduled flight of the T-37 pace aircraft. The flight recorder and strain gage instrumentation are turned on before takeoff and prior to landing to record strains of ground loads. In the ten months to date, some 140 sorties have been flown, accounting for about 690 landings (the high number of landings is due to the fact that pilots use the T-37 for proficiency flying, which involves touch-and-go practice landings). In this length of time, strain values and presumably loads have never exceeded those experienced during the initial flight testing. The side brace has been removed three times during this period for x-ray inspection, with no changes detected.

SECTION VII
FOLLOW-ON TESTS

The graphite side brace on the T-37 at 4950th Test Wing will stay in service for a total of one year. One follow-on test being considered is the installation and service test of a new design graphite side brace on the same T-37. The new side brace is fabricated from what is expected to be a better material system, Hercules 3501-6/AS composite. Aluminum bushings have been replaced with aluminum-nickel-bronze bearings. These are not molded into the parts any longer, but are bonded in place after the composite is cured. The upper and lower side braces are now being cured in steel molds, rather than the original graphite/epoxy molds. This will allow more consistent dimensional reproducibility and longer mold life.

A second follow-on test will be to install and service test graphite side braces on the heavier A-37 for which they were originally designed.

A final series of tests which is being conducted at the Flight Dynamics Laboratory is a combined environments series. The environmental tests described in Section IV consisted of singularly-applied environments such as moisture, abuse, or fatigue, followed by a static ultimate test. It did prove the hardware's ability to retain its strength after prolonged exposure to each of these environments. In reality, however, several conditions are usually present at once, which has raised the question of how the same hardware would fare under combined environments. The resulting follow-on series of tests will be determining the ability of the composite hardware to function under prolonged fatigue loading, moisture, temperature, and abuse simultaneously.

SECTION VIII

CONCLUSIONS

The objective of the Composite Landing Gear Program was to demonstrate the feasibility of composite material landing gear. This has been fully accomplished in the case of the A-37 graphite/epoxy side brace through development and fabrication, static and fatigue tests, environmental testing, flight test, and operational service. The graphite side brace was designed to be completely interchangeable with its production aluminum counterpart on the A-37 and T-37 aircraft. It has evolved through several design, fabrication, and material iterations precipitated by extensive in-house testing. It is now an airworthy component of the T-37 pace aircraft flown by the 4950th Test Wing at Wright-Patterson Air Force Base.

REFERENCES

1. Hercules, Inc., Graphite Composite Landing Gear Components - Side Brace Assembly and Torque Link for A-37B Aircraft, AFFDL TR 73-69, 15 May 1973.
2. Dexter, Peter F., Graphite/Epoxy Landing Gear Environmental Tests, AFFDL TM-74-217-FEM, November 1974.

APPENDIX A
GRAPHITE SIDE BRACE TEST FATIGUE SPECTRUM*

Cycle No.	Maximum Load (lb)	% of Design Limit Load	Minimum Load (lb)	% of Design Limit Load	Cycles/Block
1	-1623	8	-7240	36	201
2	1186	13	-7240	36	8
3	-7240	36	-12857	65	87
4	-7240	36	-16000	80	5
5	+1487	16	-4270	21	1
6	+1289	14	-3414	17	4
7	+1104	12	-2708	14	11
8	-3027	15	-7240	36	19
9	-1623	8	-7240	36	6
10	-219	2	-7240	36	2

Total Cycles/Block = 344

Rate = 10/min

1 Block = 100 Flights

1 Lifetime = 70 Blocks = 24080 Cycles

Design Limit Load (+) = 9,200 lb tension

Design Limit Load (-) = 19,900 lb compression

*Fatigue test spectra for torque link and side brace established by Mr. T. Derber, A-37B Landing Gear Fatigue Group, Cessna Military Twin Aircraft, Wichita, Kansas, and furnished to Captain G. C. Shumaker for test purposes.

APPENDIX B

PROOF TEST STRAIN VS. LOAD

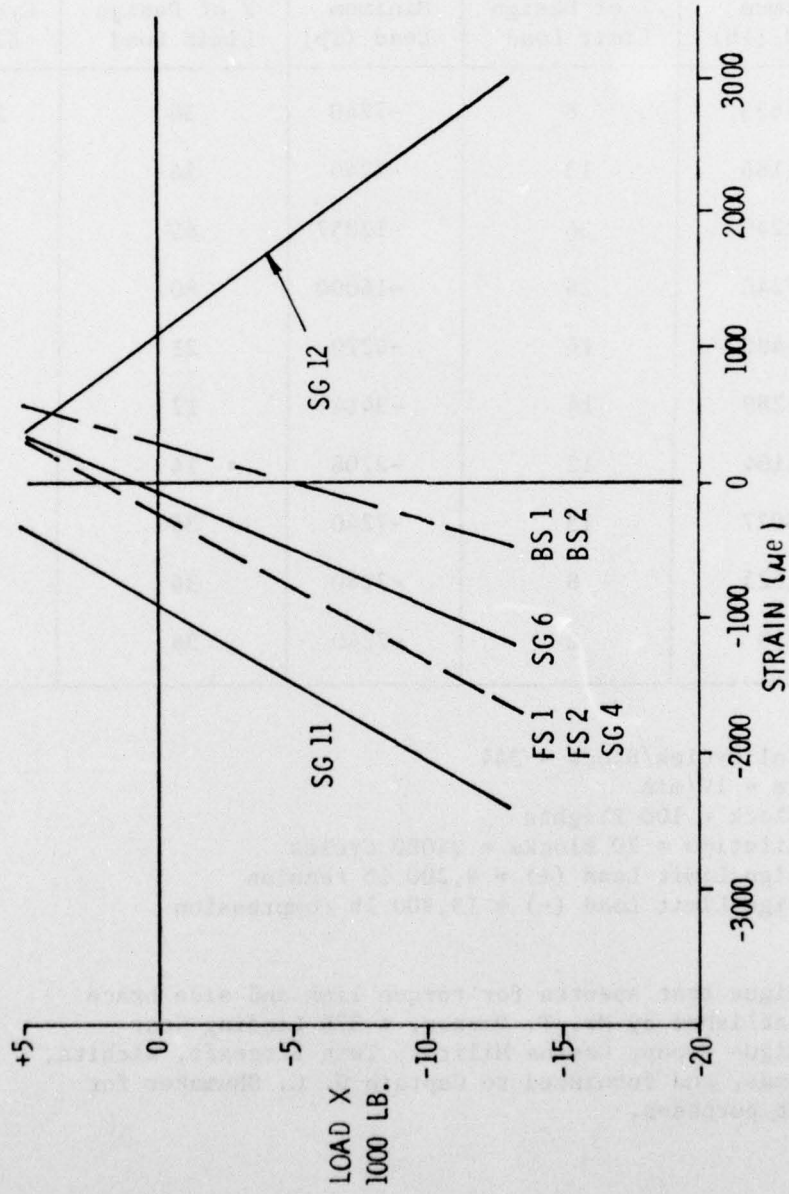

APPENDIX C
MAXIMUM LOADS & STRAIN

	<u>T-37B Flight Test</u>	<u>T-37B Proof Test</u>	<u>A-37B Normal Fatigue Test</u>	<u>A-37B 125% Fatigue Test</u>
COMPRESSION				
Load (lb)	-5000	-13000	-16000	-20000
Strain ($\mu\epsilon$)				
FS1, FS2	-1000	- 1700	- 1300	- 1600
BS1, BS2	- 200	- 500	- 1000	- 1400
SG4	- 800	- 1800	- 900	- 2400
SG6	-1000	- 1200	- 1100	- 3700
SG11	-1100	- 2400	- 1600	- 3100
SG12	1900	2800	2200	4250
TENSION				
Load (lb)	3000	5500	1400	1900
Strain ($\mu\epsilon$)				
FS1, FS2	200	300	200	200
BS1, BS2	600	600	150	100
SG4	400	500	200	200
SG6	370	500	100	50
SG11	0*	300	0	0
SG12	0*	400	0	0

*Side Brace Unlocked

APPENDIX D

SAMPLE STRAIN DATA

This section of strip chart shows the strain data from landings 8 & 9 of the second flight. The bending load imposed on the side brace by the overcenter downlock spring is clearly seen on all channels except SG6, which is located on the neutral axis of the lower arm. On this particular flight there is some noise on SG6. The data shows that even severe landings such as this produce relatively low strains. On landing 8 SG 12 records the highest load seen on the test. This impulse load corresponds to a load of ≈ 5000 lbs, or $\approx 30\%$ of T37 design limit load.

