

AD-A045 904

STANFORD RESEARCH INST MENLO PARK CALIF F/G 6/1
QUANTITATIVE DETERMINATION OF SUBSTANCES OF BIOLOGICAL ACTIVITY--ETC(U)
AUG 77 G A ST. JOHN, M ANBAR, J H MCREYNOLDS DAAG29-76-C-0056
ARO-13691.1-L NL

UNCLASSIFIED

1 OF 1
ADA
045904



END
DATE
FILMED
12-77
DDC

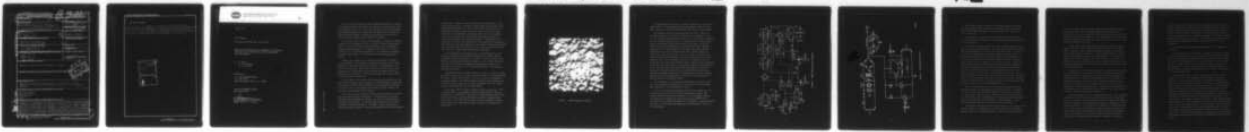

END
DATE
FILMED
12 77 12 77

12 ARO 13691.1-L

18
19

REPORT DOCUMENTATION PAGE
READ INSTRUCTIONS BEFORE COMPLETING FORM

1. REPORT NUMBER: 13691.1-L
2. GOVT ACCESSION NO.
3. RECIPIENT'S CATALOG NUMBER: 9

4. TITLE (and Subtitle): Quantitative Determination of Substances of Biological Activity by Field Ionization and Field Desorption Mass Spectrometry
5. TYPE OF REPORT & PERIOD COVERED: Final Report, 15 Jun 76 - 14 Jun 77
6. PERFORMING ORG. REPORT NUMBER

7. AUTHOR: G. A. St. John, M. Anbar, J. H. McReynolds
8. CONTRACT OR GRANT NUMBER(s): DAAG29-76-C-0056

9. PERFORMING ORGANIZATION NAME AND ADDRESS: Stanford Research Institute, Menlo Park, California 94025
10. PROGRAM ELEMENT, PROJECT, TASK AREA & WORK UNIT NUMBERS

11. CONTROLLING OFFICE NAME AND ADDRESS: U. S. Army Research Office, Post Office Box 12211, Research Triangle Park, North Carolina 27709
12. REPORT DATE: Aug 77
13. NUMBER OF PAGES: 10

14. MONITORING AGENCY NAME & ADDRESS (if different from Controlling Office): 12-13p.
15. SECURITY CLASS. (of this report): Unclassified
15a. DECLASSIFICATION/DOWNGRADING SCHEDULE

16. DISTRIBUTION STATEMENT (of this Report): Approved for public release; distribution unlimited.

17. DISTRIBUTION STATEMENT (of the abstract entered in Block 20, if different from Report):
D D C
NOV 2 1977
RESERVE
F.

18. SUPPLEMENTARY NOTES: The findings in this report are not to be construed as an official Department of the Army position, unless so designated by other authorized documents.

19. KEY WORDS (Continue on reverse side if necessary and identify by block number):
Mass spectrometry
Biological materials
Spectrometers
Silicon

20. ABSTRACT (Continue on reverse side if necessary and identify by block number):
The objective of this project has been to develop instrumentation and methodologies for quantitative determination of nanomole and possibly picomole amounts of materials of biological interest using field desorption (FD) and isotope dilution techniques. In the first two-year phase of this program, it was intended to develop a number of FD techniques and select the best of these for quantitative assay. To achieve the latter goal a CEC 21-110B double focusing mass spectrometer was modified to accommodate an FI-FD source. It was planned to use the integrating capability of the photoplate attachment for quantitative assay - to overcome the intrinsic fluctuations of FD.

ADA 045904

DDC FILE COPY

332 590

JP

20. ABSTRACT CONTINUED

sources. Owing to the transfer of the Principal Investigator from SRI to become Chairman of the Department of Biophysical Sciences at the State University of New York at Buffalo, the project is terminating at the end of its first year. Most of the effort of the first year has been invested in the modification of the CEC mass spectrometer and in the development of ion sources.

ACCESSION for	
THIS	Wide Section <input checked="" type="checkbox"/>
DDC	B.H. Section <input type="checkbox"/>
NANNOING D	<input type="checkbox"/>
J. S. H. I. G. A. I. S. I.	
BY	
DISTRIBUTION/AVAILABILITY CODES	
Dist.	SPECIAL
A	



STANFORD RESEARCH INSTITUTE
Menlo Park, California 94025 · U.S.A.

August 1977

Final Report

Covering Period June 1976 to June 1977

QUANTITATIVE DETERMINATION OF SUBSTANCES OF BIOLOGICAL
ACTIVITY BY FIELD IONIZATION AND FIELD DESORPTION
MASS SPECTROMETRY

By: M. Anbar
J. H. McReynolds
G. A. St. John

Prepared for:

U. S. ARMY RESEARCH OFFICE
P. O. Box 12211
Research Triangle Park, N. C. 27709

Contract DAAAG29-76-C-0056
SRI Project 5510

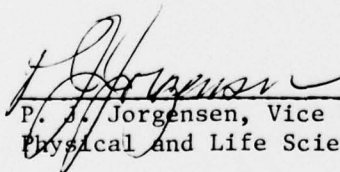
P. J. Jorgensen, Vice President
Physical and Life Sciences

This is the final report on project DAAG29-76-C-0056 which covered the period June 1976 to June 1977. The objective of this project, which was intended to take five to six years, has been to develop instrumentation and methodologies for quantitative determination of nanomole and possibly picomole amounts of materials of biological interest using field desorption (FD) and isotope dilution techniques.

In the first two-year phase of this program, we intended to develop a number of FD techniques and select the best of these for quantitative assay. To achieve the latter goal, we modified a CEC 21-110B double focusing mass spectrometer to accommodate an FI-FD source. We then planned to use the integrating capability of the photoplate attachment for quantitative assay - to overcome the intrinsic fluctuations of FD sources.

Owing to the transfer of the Principal Investigator from SRI to become Chairman of the Department of Biophysical Sciences at the State University of New York at Buffalo, the project is terminating at the end of its first year. Most of the effort of the first year has been invested in the modification of the CEC mass spectrometer and in the development of ion sources. The mass spectrometer has now been transferred to Buffalo with the P.I.

In the course of this year, we have carried out work which may have significant bearing on future research. We have developed two new types of FD sources, but have not yet critically evaluated their performance. The first of these is an etched silicon source, and the second is an electrolytically activated cobalt source.

The first source was based on an SRI proprietary process to obtain large nonreflecting areas of silicon. In this process, the silicon undergoes radiation damage by exposure to a source of alpha particles, followed by mild etching. The etched surface exhibits a free uniform crystalline structure (Figure 1). The edges of these crystals have sufficiently high curvature to allow field ionization or field desorption

to take place. Moreover, since the silicon can be machined to a well defined geometry prior to etching, a well-defined field desorber can be fabricated. Miniature rods 1 mm in diameter and 3 mm long have been fabricated from silicon and etched. The etched surfaces were then coated with a few monolayers of chromium carbide to prevent oxidation of the silicon surface and to allow easier induction of growth of carbonaceous dendrites (for field ionization). In preliminary tests, as we shall see later, the performance of these desorbers, though easily controllable was not found superior to the previously used broken tungsten rods, but these results are qualitative and rather nonconclusive since they could not be tested under quantitative conditions.

The electrolytically activated cobalt field desorbers have been produced by modifying the procedure of Rechtsteiner, Mathis, Bursey, et al (Bio. Med. Mass Spectrom. 4, 52 (1977)). A novel pulsing circuit has been designed and constructed (Figures 2 and 3). This circuit has been used to electrolyse 6N $\text{Co}(\text{NO}_3)_2$ and deposit microdendrites of cobalt on soft iron rods or on razor blade shim stock. The circuit is described as follows:

The dendrite pulse can supply pulses at a rate of 1 every 5 seconds to 500 per second, at pulse widths of 50 microseconds to 100 milliseconds. The pulses can vary from 3 volts to 110 volts, and a few milliamperes to several amperes. The current should be limited with a suitable load resistor to prevent damage to the output transistor from high voltage pulses, high repetition rates, and wide pulses.

An IC timer (555) is used to generate the basic clock rate. This is counted down by a programmable 3 decade counter (9310's) allowing selection of 1 to 999 pulses. One-half of a MC14538B multivibrator (MV) is used for locking out the start button to prevent retriggering on short counts. The other half of the MV is used to generate a variable width output pulse. Nand and nor gates are used for synchronization and control.

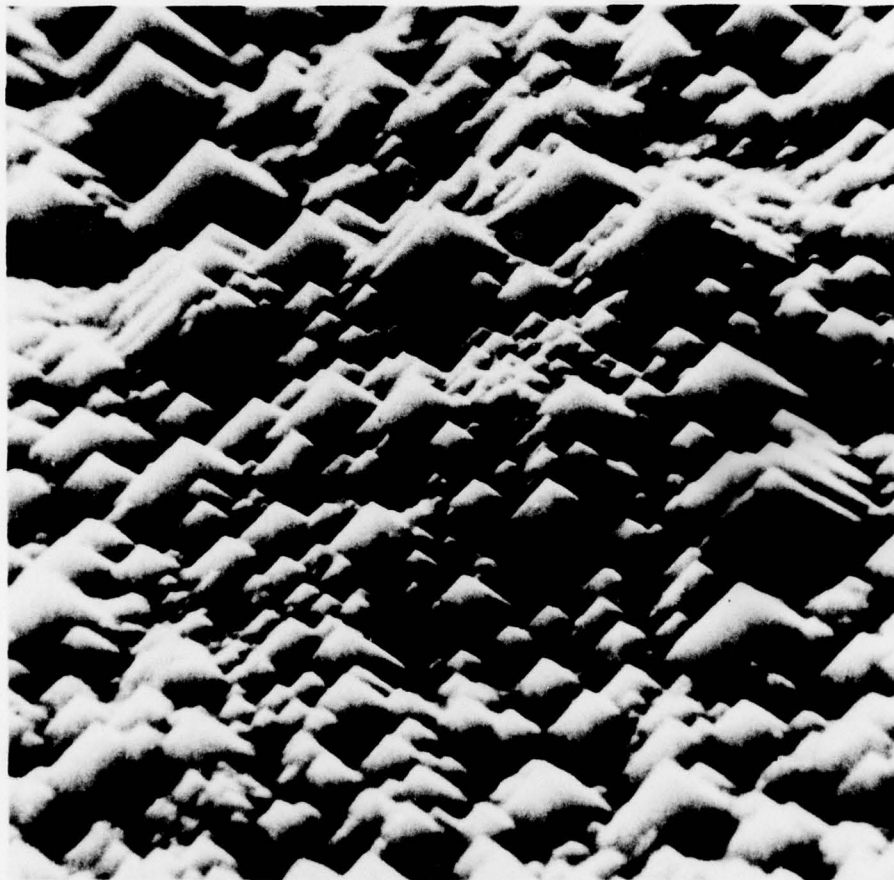

FIGURE 1 ETCHED SILICON FD SURFACE

The power amplifier utilizes a variable transformer to control the output voltage. A high voltage high power darlington transistor and large capacitor (0.11 farad) allow a wide range of power output pulses.

The dendrites have been best grown when many (50 to 100) short (0.5 msec) pulses of 30 to 40 V were applied over a distance of 3 mm at 95°C. Although the preliminary tests on the field desorbers produced by this technique showed them not to be superior to the broken tungsten rods or the chromium carbide coated silicon structures, the linear cobalt activated field ionization sources have been found comparable in performance to the high temperature activated carbonaceous dendrite tantalum sources (Cross, Brown and Anbar, Rev. Scient. Instrum. 47, 1270 (1976). Moreover, they seem to be less prone to deactivation by negative counter-ion bombardment. In view of this and of their ease of production, the cobalt activated slit type field ionization sources superceded their carbonaceous dendrite analogs and were used successfully on two other U.S. Army projects: Contract No. DAMD17-74-C-4047 entitled "Field Ionization Mass Spectrometric Rapid Diagnosis of Infectious Diseases," under sponsorship of the U.S. Army Medical Research and Development Command, and Contract No. DAAA15-76-C-0135 entitled "Rapid Identification of Microorganisms by Their Nucleic Acid Composition," under sponsorship of Edgewood Arsenal.

The preliminary field desorption experiments, which were carried out on an inadequate multiscanning 60° 35 cm radius, single focusing mass spectrometer, are summarized as follows:

A test of various field desorption emitters was carried out. The counter-electrode grid of the ionizer was grounded through a 10M Ω resistor and the emitters were operated at 5 kV accelerator voltage. The emitters were inserted into the source using a MACORTM probe incorporating a micrometer adjustment of the emitter to counter-electrode spacings. The source-emitter temperature was maintained at 150°C for all measurements.

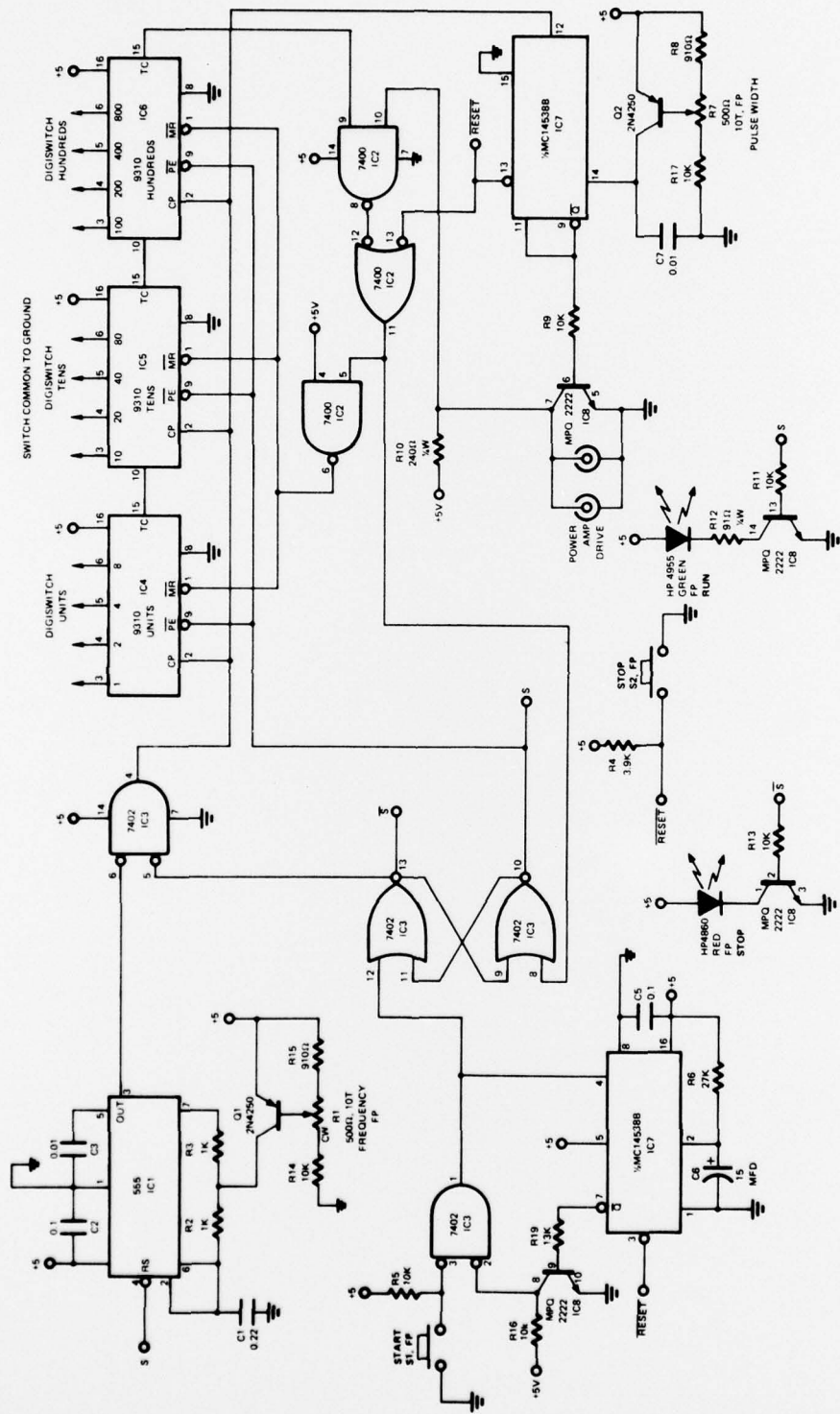
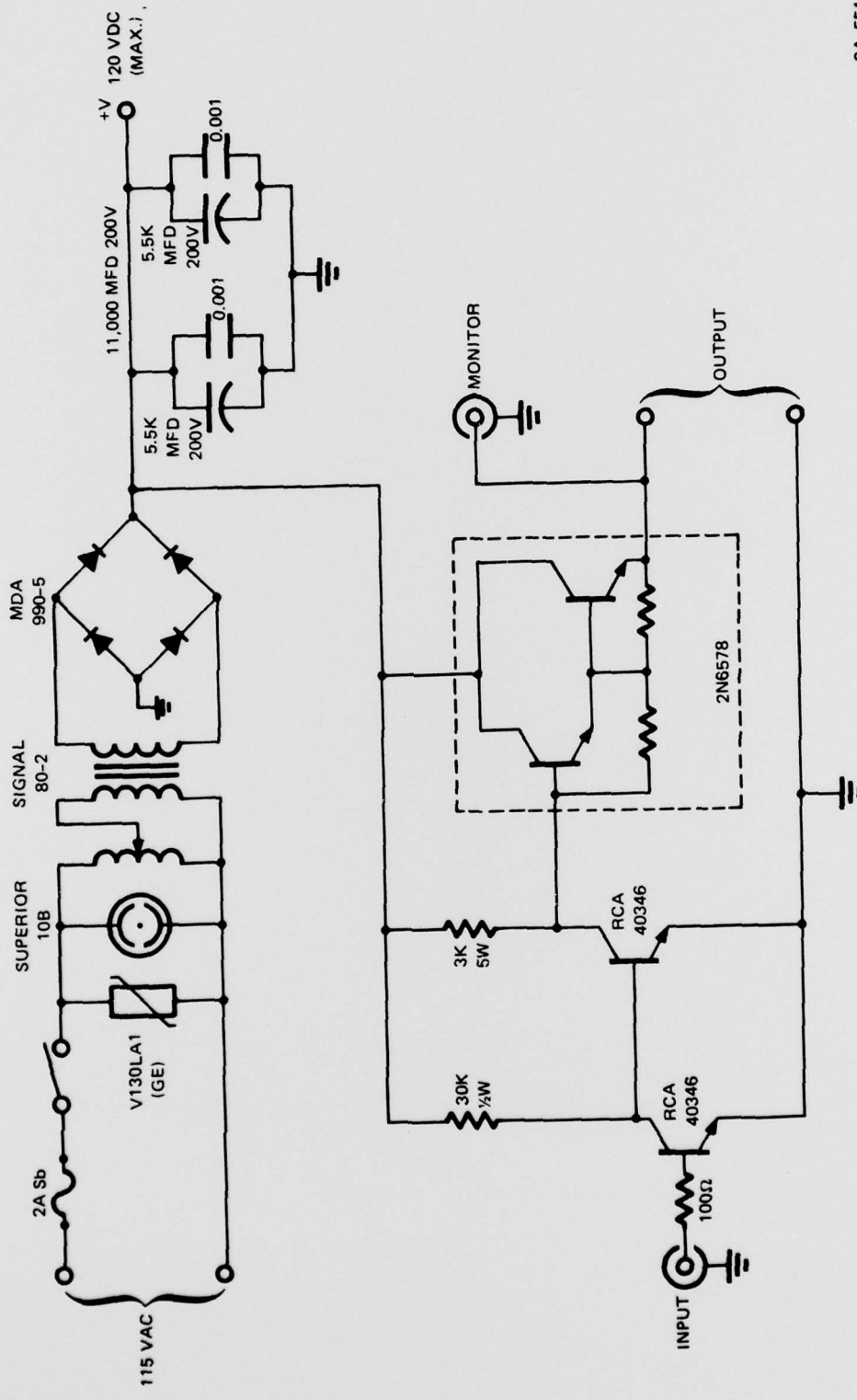

FIGURE 2 TIMER AND PULSE WIDTH CONTROL



SA-5510-1

FIGURE 3 PULSER POWER AMPLIFIER

The following emitter types were tested under similar conditions and sample loads: broken tungsten rods, etched silicon rods, carbon rods, carbon TYNELTM filaments, and cobalt dendrites on iron rods or steel razor blades.

Each emitter was tested both with measured 200-1000 ng amounts or with large loadings (estimated 5-10 μg) of tetraphenyl porphine (MW 614) as a test material.

Of the emitters tested, only the carbon filaments showed molecular ions at the lower sample loadings. The carbon rod produced weak fragment ions at approximately m/e 415 with the lower sample loads. The weak molecular ions observed with the carbon filaments appeared at very low fields when the emitter was 25-50 mils from the counter-electrode. It is likely that these ions were actually produced by FI/FD from single fibers pulled out of the bundle to a much closer spacing. Attempts to obtain higher ionization efficiency by decreasing the spacing usually resulted in momentary short circuits of the emitter counterelectrode potential. Further decrease of the spacing resulted in a series of organic fragment ions followed by a replacement of the organic ions by strong Na^+ and K^+ signals. The source of these ions may be a proprietary coating of unknown compositions which is applied to the fibers and part of the manufacturing process. Similar behavior was observed with larger loadings of sample on the carbon filament emitters.

With all other ionizer types, no ionization occurred unless some measurable current was drawn in the emitter-grid circuit. A current of 1 μA was typically observed which resulted in a mass shift indicative of a drop in the final ion energy. Observation of the ion beam shape on a multichannel plate image intensifier indicated considerable energy spread in the beam and the decomposition of large numbers of ions in the emitter-grid region or in the first field free spacing.

The tungsten rods had an erratic ionization due to the nature of the fractured surface. Following use, a single high spot on the surface showed evidence of a sustained discharge. The etched silicon crystals

gave a very sharp transition, over a narrow range of spacings, between no ionization and a severe breakdown producing a discharge type of ionization. This is not surprising since the surface is plain with only micron sized surface irregularities. The used emitters with Ni dendrites typically showed sections where the dendrites had been lost and the edge partially melted back by arcing.

A final test was performed using a carbon rod ground to a wedge shape. This emitter was charged with guanine riboside in a saturated sucrose solution. Some residual tetraphenyl porphine was also present on the carbon from a previous test. After partial drying, the sucrose matrix left the emitter coated with a glassy deposit. The emitter was pumped in the source housing at $\sim 100^{\circ}\text{C}$ for 30 min before voltage was applied. At larger spacings, modest fields and 150°C , some m/e 415 ions from the porphine were observed along with possible ribose, hexose, and guanine fragment ions.

The spacing was further decreased until a voltage drop occurred and a strong fragment ion spectrum was observed. The emitter spacing was restricted until the voltage drop was reduced, but still maintaining strong ionization. Under these conditions, the m/e 415 fragment ions persisted along with a diffuse series of metastable fragment ions in the range of 200-250 amu. After operation for 30 min to 1 hr, this emitter was removed and examined under a microscope. The sucrose matrix had apparently been carbonized and also formed into both large visible as well as micron sized dendritic projections.

The exact mechanism for the transformation process is not completely understood at this time, but it appears that these projections, under suitable conditions, may be formed very quickly on rather blunt emitters that are incapable of producing field ionization by themselves. These projections appear to be formed from the sample or the sample matrix by the localized fields and temperatures present during the apparent discharge that exists when measurable current is drawn from the emitter. This process appears to occur only if sufficient sample or matrix is present, and furthermore, the matrix must be capable of rendering a

semiliquid state on the emitter so that it undergoes the chemical and physical transformations that produce the observed dendritic projections. This interpretation is consistent with the previous results obtained with the tungsten emitters using sucrose or polyvinyl alcohol matrices or with large amounts of oil or asphaltene samples. With smaller samples or samples that pyrolyze or vaporize, these projections do not form, and sufficient field enhancement does not occur to produce true field desorption.

The work on the CEC 21-110B mass spectrometer can be summarized as follows:

To allow the use of a CEC 21-110B for combined EI-FI-FD operation, its source was modified to provide an isolated exit slit and the window of the source housing was replaced with a ball valve, allowing a probe carrying a razor blade emitter to be inserted through the hole in the back of the standard CEC source. An initial attempt was made to use the repellers as a counter electrode, but the small ruby insulators did not maintain adequate potential between the repellers and the block to allow field ionization.

The source was found to operate adequately, although at reduced sensitivity in the EI mode without the source magnet or repellers installed. A pair of mycalexTM plates were machined to hold an exit slit that was isolated from the block. This slit was grounded and the block operated at the normal accelerating potential. Even without an emitter in place, the arrangement suffered from intermittent voltage breakdowns and leakage. Low sensitivity field ionization was then obtained by using an auxiliary power supply operated at 150-200V above the nominal accelerating voltage corresponding to the electric sector voltage range. This mode of operation indicated a severe leakage problem associated with both the standard source insulator posts and the mycalex plates. Due to the unstable nature of this leakage, it was not possible to maintain a steady beam, since the ion energy fluctuated too widely to be continuously transmitted through the electric sector. A ceramic slit holder is being constructed that will eliminate the voltage leakage and breakdown and allow operation with the standard CEC ion accelerator supply.

A probe is also being designed that will allow external alignment of the blade with the counter electrode slit. Following successful operation in the EI mode, the source magnet and repellers were planned to be modified to allow insertion of the FI-FD emitter while still maintaining optimum EI operation for calibration and tune-up.

To summarize: Due to unforeseen circumstances resulting from the transfer of the Principal Investigator from SRI, a multi-year research program is being terminated at the end of its first year. The work accomplished comprises modification of the mass spectrometer, which has been transferred with the P.I., and ion source development. The ion source work has also contributed significantly to two other U.S. Army sponsored projects, which have reached maturity, and the contribution of the present project will be acknowledged in the appropriate publications (now under preparation).