

AD-A046 082

COMPUTER SCIENCES CORP FALLS CHURCH VA  
LAYAWAY PLAN FOR DIRECT DIGITAL CONTROL (DDC) SYSTEMS ON THE CO--ETC(U)  
OCT 75

F/G 19/1

DAAA21-75-C-0244

UNCLASSIFIED

CSC/SD-75/4137

NL

1 OF 3  
ADA  
046082

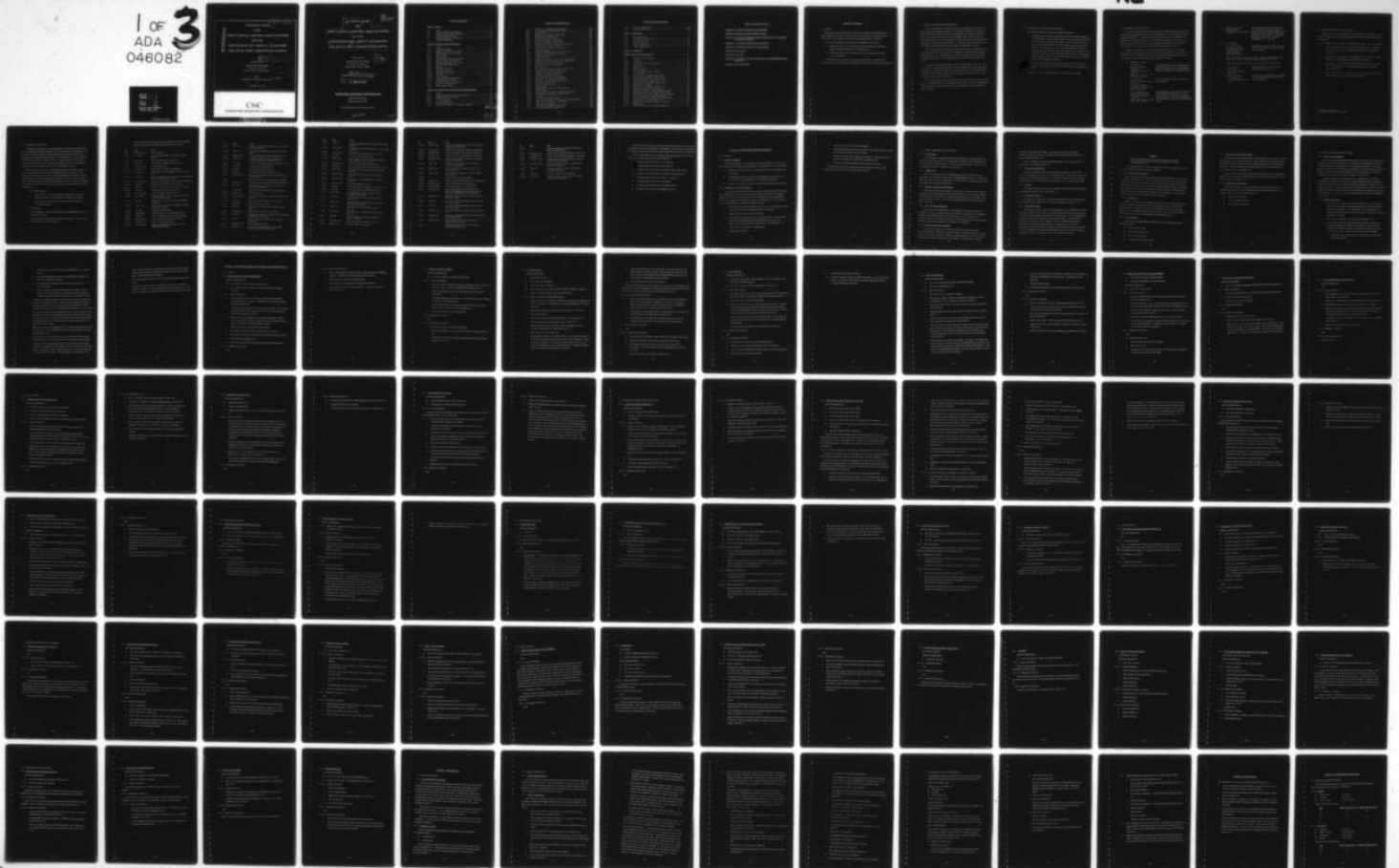

AD A 046082

LAYAWAY PLAN

12

CSC/SD-75/4137

FOR

DIRECT DIGITAL CONTROL (DDC) SYSTEMS

ON THE

CONTINUOUS TNT LINES AT VOLUNTEER

AND JOLIET ARMY AMMUNITION PLANTS

COPY AVAILABLE TO DDC DOES NOT  
PERMIT FULLY LEGIBLE PRODUCTION

Prepared for

UNITED STATES ARMY  
Picatinny Arsenal  
Dover, New Jersey 07801

DDC  
RECEIVED  
NOV 2 1977  
A

Under

CONTRACT DAAA21-75-C-0244

OCTOBER 10, 1975

CSC

COMPUTER SCIENCES CORPORATION

DISTRIBUTION STATEMENT A

Approved for public release;  
Distribution Unlimited

14

CSC/SD-75/4137

6

LAYAWAY PLAN  
 FOR  
DIRECT DIGITAL CONTROL (DDC) SYSTEMS  
 ON THE  
CONTINUOUS TNT LINES AT VOLUNTEER  
AND JOLIET ARMY AMMUNITION PLANTS .

Prepared for  
 UNITED STATES ARMY  
 Picatinny Arsenal  
 Dover, New Jersey 07801

12 277 p.

15 Under  
 CONTRACT DAAA21-75-C-0244 *new*

11 10 OCTOBER 10 1975

**COMPUTER SCIENCES CORPORATION** ✓

6565 Arlington Boulevard  
 Falls Church, Virginia 22046

Major Offices and Facilities Throughout the World

405 717

YB

TABLE OF CONTENTS

<u>Section 1 - General</u> . . . . .	1-1
1.1 Scope . . . . .	1-1
1.2 Overall Approach to Mothballing . . . . .	1-2
1.3 Overview of the Periodic Maintenance . . . . .	1-3
1.4 Potential Computer Users . . . . .	1-4
1.5 Periodic Maintenance Contractors . . . . .	1-6
1.6 Applicable Documents . . . . .	1-7
<u>Section 2 - Laying Away the Control System</u> . . . . .	2-1
2.1 General . . . . .	2-1
2.1.1 Layaway Philosophy . . . . .	2-1
2.1.2 Sequence for the Layaway Process . . . . .	2-1
2.2 General Procedures for Layaway . . . . .	2-3
2.2.1 Unused Lines . . . . .	2-3
2.2.2 Orifice Plates . . . . .	2-3
2.2.3 Marking Control System Components . . . . .	2-3
2.2.4 Order of Layaway Procedures . . . . .	2-3
2.2.5 Hydraulic Pump House Equipment . . . . .	2-3
2.2.6 Power to Field Equipment . . . . .	2-4
2.2.7 Desiccant . . . . .	2-4
2.2.8 Moisture-Proof Tape . . . . .	2-4
2.2.9 Hydraulic Oil System . . . . .	2-4
2.2.10 Filling With Dry Nitrogen . . . . .	2-5
2.2.11 Instrument Air . . . . .	2-5
2.2.12 Waste Disposal . . . . .	2-5
2.2.13 Protection from Weather and Dirt . . . . .	2-6
2.2.14 Emergency Phone Numbers . . . . .	2-6
2.3 Specific Procedures for Layaway . . . . .	2-7
2.3.1 Process Area Components . . . . .	2-7
2.3.2 Central Control House . . . . .	2-7
<u>Section 3 - Procedures for Process Controls and Instrumentation</u> . . . . .	3-1
3.1 Valves . . . . .	3-1
3.1.1 Poppet Plug Valve, Type F45 and Type 5310 . . . . .	3-1
3.1.2 Saunders Type Valves Type G2 . . . . .	3-3
3.1.3 V1 Control Valves . . . . .	3-4
3.1.4 V-4A Needle Valve . . . . .	3-6
3.1.5 Ball Valve Model 9000 . . . . .	3-8
3.1.6 Anderson, Greenwood 3-Valve Bypass Manifold . . . . .	3-10

*Letter on file*

SEARCHED	INDEXED
SERIALIZED	FILED
A 23	

TABLE OF CONTENTS (Cont'd)

3.1.7	Model X53, X55, Skinner Solenoid Valves . . . . .	3-11
3.1.8	3-Valve Bypass Manifold Model BM-SS-3V . . . . .	3-12
3.2	Level Controls . . . . .	3-13
3.2.1	Liquid Level Transmitters Series E17D . . . . .	3-13
3.2.2	Magnetrol Level Switches TF-63 . . . . .	3-15
3.2.3	Mercoild Liquid Level Controls . . . . .	3-17
3.3	Pressure Transmitters and Controls . . . . .	3-19
3.3.1	Pressure Transmitter Model E11GM . . . . .	3-19
3.3.2	Differential Pressure Transmitter, Model E13D . . . . .	3-21
3.3.3	Liquid Level Transmitters Series 13F . . . . .	3-25
3.3.4	Mercoild Series "D" Pressure Controls . . . . .	3-27
3.4	Temperature Sensors . . . . .	3-29
3.4.1	Dynatherm Resistance Bulbs Model DB-2 Series . . . . .	3-29
3.4.2	DAH-35 Mercoild Thermal Limit Switch . . . . .	3-30
3.5	Converters and Alarms . . . . .	3-32
3.5.1	Alarms Model 63R . . . . .	3-32
3.5.2	Resistance-to-Current Converter Model 694A, Style C . . . . .	3-33
3.5.3	Magnetic Flow-to-Current Converter, Model 696A . . . . .	3-34
3.5.4	pH-to-Current Converter Model 699 . . . . .	3-36
3.5.5	Frequency Converter, Model 99V . . . . .	3-37
3.6	Flow and Speed . . . . .	3-38
3.6.1	Flow Switch, McDonnell and Miller Model FS-7-SE . . . . .	3-38
3.6.2	Magnetic Flow Transmitters Series 2800 . . . . .	3-39
3.6.3	Magnetic Pickup Electro Model 3070 . . . . .	3-40
3.7	Positioners and Position Indicators . . . . .	3-41
3.7.1	Microswitch 4EX-1, EX-AR, EXD-AR . . . . .	3-41
3.7.2	Current-to-Air Positioner Model 69PA-1 . . . . .	3-42
3.7.3	Current-to-Air Transducer, Model 69TA-1 . . . . .	3-43
3.7.4	Position Transmitter Type CP . . . . .	3-44
3.7.5	Type C Vernier Valvactor . . . . .	3-45
3.8	Miscellaneous . . . . .	3-46
3.8.1	Outdoor Storage of Valves and Transmitters . . . . .	3-46
3.8.2	pH Electrodes . . . . .	3-47
3.8.3	Buoyancy Level Transmitters Models 17BS and 17BT . . . . .	3-48
3.8.4	Field Mounted Preampifier Model PA-106A . . . . .	3-50
3.8.5	Air Filter . . . . .	3-51
3.8.6	Fixed Pressure Filter Regulator . . . . .	3-52
3.8.7	Type 67 Supply Regulator and Type 67 FR Filter-Regulator . . . . .	3-53
3.8.8	Indoor Storage of Valves and Transmitters . . . . .	3-54
3.9	Recorders and Controllers . . . . .	3-55
3.9.1	DDC Manual Backup Station Model 62 HD . . . . .	3-55
3.9.2	DDC Backup Controller Model 67 HD . . . . .	3-56

TABLE OF CONTENTS (Cont'd)

3.9.3	Recorders Model 6400H . . . . .	3-57
3.9.4	Model ERB Recorder . . . . .	3-58
<u>Section 4 - Maintenance . . . . .</u>		4-1
4.1	Daily Maintenance . . . . .	4-1
4.1.1	Environmental Control Systems . . . . .	4-1
4.1.2	Protective Coverings . . . . .	4-1
4.2	Yearly Maintenance . . . . .	4-2
4.2.1	Process Equipment Areas . . . . .	4-2
4.2.2	Central Control House . . . . .	4-2
<u>Section 5 - Reactivation . . . . .</u>		5-1
<u>Section 6 - Recommended Spare Parts . . . . .</u>		6-1
6.1	Parts for Field Components . . . . .	6-1
6.1.1	V1 Valves . . . . .	6-1
6.1.2	V-4A Valves . . . . .	6-1
6.1.3	F-45 Valves and Model 5310 Valves . . . . .	6-1
6.1.4	V9000 Valves . . . . .	6-2
6.1.5	Saunders G2 Valve . . . . .	6-2
6.1.6	P Series Actuators . . . . .	6-2
6.1.7	X53, X55 Skinner Electric Solenoids . . . . .	6-3
6.1.8	Air Set B110XR . . . . .	6-3
6.1.9	Current-to-Air Positioner Model 69PA-1 . . . . .	6-3
6.1.10	Current-to-Air Transducer, Model 69TA-1 . . . . .	6-3
6.1.11	Microswitch Model 4EX1, EX-AR, EXD-AR . . . . .	6-4
6.1.12	Level Transmitters, Model 13FA . . . . .	6-4
6.1.13	Buoyancy Level Transmitter, Model E17BT . . . . .	6-4
6.1.14	Series E10 Transmitters . . . . .	6-4
6.1.15	Liquid Level Transmitters, Series E17D . . . . .	6-5
6.1.16	Pressure Transmitter, Model E11GM . . . . .	6-5
6.1.17	Differential Pressure Transmitters, Series E13D . . . . .	6-5
6.1.18	McDonnell and Miller Flow Switch, Model FS-7SE . . . . .	6-6
6.1.19	Mercoïd Pressure Switch, Models DAH-21 and DAH-31 . . . . .	6-6
6.1.20	Mercoïd Temperature Switch, Model DAH-35 . . . . .	6-6
6.1.21	Mercoïd Level Switch, Model 401E and Model 301E . . . . .	6-6
6.1.22	Magnetrol Level Control, Model TF-63 . . . . .	6-6
6.1.23	Magnetic Flow-to-Current Converter, Model 696A . . . . .	6-7
6.1.24	pH Electrodes . . . . .	6-7
6.2	Parts for Control House Electronic Equipment . . . . .	6-8

TABLE OF CONTENTS (Cont'd)

Appendix A-1 - Anderson Greenwood 3-Valve Manifolds

Appendix A-2 - Electro Corporation Magnetic Pickups

Appendix A-3 - Mercoird Corporation Temperature Switches, Pressure Switches,  
and Liquid Level Controls

Appendix A-4 - Magnetrol Division Liquid Level Controls

Appendix A-5 - Skinner Electric Valves - Solenoid Valves

Appendix B - Preservatives

Appendix C - Water Test

Appendix D - Cross Reference List of TAG Numbers of Loops Containing Selected  
Components

Appendix E - Layaway Checklist

## SECTION 1 - GENERAL

### 1.1 SCOPE

↘ This plan defines the procedures to be followed in laying away, maintaining, and reactivating the DDC systems (Foxboro Model PCP-88) for the CIL continuous TNT production lines at the Volunteer and Joliet Army Ammunition Plants. It includes ✓

- ✓ the general procedures to be followed throughout the control system,
- ✓ specific procedures for each part of the system including the sensing and control equipment installed in the production area, and,
- ✓ checklists to help assure that all the necessary equipment has been laid away or reactivated.

This plan does not cover the process equipment or buildings. It assumes that another plan exists for storing and reactivating this portion of the CIL production facility. ←

## 1.2 OVERALL APPROACH TO MOTHBALLING

All sensors, actuators, and controls in the process buildings will be laid away in such a manner that no further attention will be required until the plant is reactivated. Refer to Section 3 for detailed procedures and Appendix E for checklists to follow for layaway and reactivation of these classes of equipment. In the control house the air conditioning equipment will remain running to keep the relative humidity below 45 percent and the temperature between 45<sup>o</sup> F and 90<sup>o</sup> F. To conserve energy, the temperature controls will be set to the low limit in the winter and to the high limit in summer.

All electrical power to the line panels, the operator's console, and the digital and analog equipment racks will be turned off. Maintenance on this electronic equipment will be done once a year, according to the procedures specified herein, by a qualified maintenance contractor to be selected by the government at the time the plant is laid away.

If the government can find qualified users who will be willing to enter into a long-term agreement to maintain the computers, the two computers will be left in operation. If qualified users cannot be found, the power to the two computers will be turned off and maintenance of the computers will be done during the yearly maintenance of the other electronic equipment in the control house.

All electronic equipment located in the Hydraulic Pump House will be preserved in place. The building will be sealed to minimize air flow into or out of it. Dehumidifiers will be installed in each Hydraulic Pump House to maintain the relative humidity at or below 45 percent.

### 1.3 OVERVIEW OF THE PERIODIC MAINTENANCE

There are two objectives for the yearly maintenance program:

1. To find and repair all failures which may exist in the electronic equipment in the Control House. This equipment includes all the analog backup controllers and alarms in the line panels, the operator's console, the two computers, and their associated peripherals and all the analog and digital input/output modules in the computer room. Since the process equipment will not be operated during this periodic maintenance program, no effort will be made to validate every contact or every analog point in the I/O rack. Validation and repair will extend, however, to all modules required to service an individual analog or digital input or output point.
2. To inspect and replace, as required, all protective plastic coverings over process equipment located both inside and outside the process buildings and tanks.

Refer to Section 4 for detailed instructions for the periodic maintenance.

#### 1.4 POTENTIAL COMPUTER USERS

The study to evaluate alternative layaway approaches concluded that keeping the computers running throughout the layaway period would be desirable. By keeping the computers continuously maintained, a major portion of the control system will be functioning at the beginning of any reactivation effort. In order to keep the computers in operation, users must be found who will be willing to pay for the regular maintenance of the computers in return for their use. Otherwise, it is more economical to turn the power off.

A number of potential users were identified at the time this plan was developed. They should be contacted whenever the decision is made to layaway the control system to determine if they are interested in entering a long-term agreement with the government. The following is a list of the potential users who expressed interest:

- Chattanooga, Tennessee
  - Mr. Ernest Lewis  
Director of Vocational  
Education  
Chattanooga Public Schools  
System  
Chattanooga, Tennessee 37402  
Phone: (615) 821-2513  
  
Plan to establish a computer sciences program  
sometime after 1977. May be some interest  
at that time depending on available funding and  
existing arrangements for computing support.
  - Dr. Peyton Hall  
Chattanooga State Community  
College  
4501 Amnicola Highway  
Chattanooga, Tennessee 37406  
Phone: (615) 698-8681  
  
May be interested in the Industrial Engineer-  
ing Department.
  - Mr. Terrance Carney  
Engineering Department  
University of Tennessee at  
Chattanooga  
Chattanooga, Tennessee 37403  
Phone: (615) 755-4503  
  
At the university, only the Engineering Depart-  
ment would likely be interested. It would  
provide hands-on experience with a process  
related computer. University computing center  
has an HP 2000 with 32 terminals for students  
to use.

- Chamber of Commerce  
819 Broad Street  
Chattanooga, Tennessee 37402

The Chattanooga Chamber of Commerce has two publications listing industries in the region. One lists over 2500 companies in the three-state industrial region centered about Chattanooga. It costs \$10. The other lists about 300 companies in the immediate metropolitan area. It costs \$2.

- Joliet, Illinois  
Mr. Thomas Fevale  
Head, Math Department  
College of St. Frances  
500 North Wilcox  
Joliet, Illinois 60435

Is probably interested. Plans to check with DEC to see if any available PDP-8 software meets his needs.

The Joliet Chamber of Commerce publishes a directory of businesses in the local county. The 1975 directory lists approximately 800 companies.

Other schools contacted which expressed no interest were the following:

Lewis University  
Dr. Szalajka  
Head, Computer Science  
Department

Lewis University already has two under-utilized computers on campus.

Joliet Junior College  
Mr. Dwight Davis  
Chairman, Technical Department

JJC has a newly established arrangement for local timesharing which should meet their needs through 1981.

## 1.5 PERIODIC MAINTENANCE CONTRACTORS

The following is a list of organizations who would be interested in responding to a Request for Proposal for maintaining the electronic portion of the control system while it is in storage:

- Foxboro Company, Foxboro, Massachusetts, Attention: Mr. Frank Cogdell
- Computer Sciences Corporation, Field Services Division, 6565 Arlington Boulevard, Falls Church, Virginia 22046, Attention: Mr. Scott Sharpe, (703-533-8877)
- SORBUS, Inc., 150 Allendale Road, King of Prussia, Pennsylvania 19406, Attention: Mr. Ronald Adams, National Marketing Manager
- Aeronutronic - Ford Corporation, Communications Systems Division, 3900 Welsh Road, Willow Grove, Pennsylvania 19090, Attention: Industrial Services Department
- \* Syntonic Technology, Inc., 6003 Executive Boulevard, Rockville, Maryland 20852, Attention: Mr. Robert Kidd, Branch Manager

---

\* Subsidiary of Control Data Corporation

## 1.6 APPLICABLE DOCUMENTS

The layaway, maintenance, and reactivation procedures defined in this plan refer to certain standard preservative coatings and methods specified by MIL Standards. They also refer to Foxboro Company Maintenance Instructions and data sheets from other manufacturers for specific pieces of equipment. These documents are to be considered as part of this layaway plan. Wherever there is a conflict between this plan and the referenced documentation, use good engineering judgment to select the best approach which will result in the minimum cost to store and reactivate the system.

This section of the plan lists the applicable Government and Foxboro documents. The Government documents are generally available and are the responsibility of the layaway contractor to provide. A set of the Foxboro Maintenance Instructions should be provided as part of each control system by the Foxboro Company in a three-ring notebook. The documents of other instrumentation manufacturers are reproduced in Appendix A of this plan. A brief description of the various preservative components is presented in Appendix B.

### 1. Government Documents

- a. MIL-STD-107E, 14 June 1974, Military Standard Preparation and Handling of Industrial Plant Equipment for Shipment and Storage
- b. MIL-P-116F, 1 February 1973, Military Specification Methods of Preservation-Packing

### 2. ICI Documents

Test Procedures for (Joliet and Volunteer) Army Ammunition Plant PCP 88 Remote Batch System

(A partial copy of this document is included in Appendix D. Full-size copies should be provided by the government.)

3. Foxboro Maintenance Instructions (It is assumed that a set of these Maintenance Instructions will be available at the plant at time of layaway.)

<u>MI</u>	<u>Date</u>	<u>Title</u>
4-120	September 1947	Pressure Gauges
4-121	July 1955	Pressure Gauges Models M and MA-6", Model MT-4-1/2"
4-162	April 1971	Mansfield and Green Pressure Seals
6-110	May 1961	Orifice Plates, Flanges, and Connections
6-130	November 1963	Determining the Flow
8-110	February 1943	Meter Runs - Liquid Flow Instruments
11-152	April 1959	Fixed-Pressure Filter-Regulator, Part No. B-110-ZM
11-155	May 1960	Type 67 Supply Regulator, Type 67FR Filter-Regulator, Part Nos. B-110-FS, B-110-XR
11-490	September 1971	Model 40C Control Relay, Parts C100CX and K108EN
11-493	August 1971	Model 40G Control Relay, Part C0135YW
12-150	June 1974	Series V1 Control Valves, with Series P Actuators
12-210	June 1968	Installation of Numatic Control Valves
12-214	November 1963	Steam Packing for F-Coded Valves
12-225	January 1968	Needle, Stabilflo, V-Port, and Toppet Valves used with Reversible Actuators
12-235	July 1971	Models P25, P50, and P110 Numatic Diaphragm Actuators
12-236	August 1974	Models P25, P50, and P110 Diaphragm Actuators, with Series V1 Valves
12-240	July 1968	Three-way Control Valves
12-260	October 1963	Saunders Type Valves, Type G2 and Type H2
12-280	April 1970	Model V9000 Ball Valve with P-Series Actuator
12-340	September 1968	Type C Vernier Valvactor, Yoke Mounted
14-132	February 1971	Type CP Position Transmitter
14-240	November 1968	Foxboro pH Measuring Electrodes, Part Nos. Q0104AW and Q0104AP

<u>MI</u>	<u>Date</u>	<u>Title</u>
14-241	July 1970	Foxboro Flowing Reference Electrodes, for pH and ORP Measurement
14-705	May 1972	Supply and Transmission Piping, Numatic Transmitters
16-123	January 1964	Dynatherm Resistance Bulbs, Model DB-1 Series
16-124	June 1964	Dynatherm Resistance Bulbs, Stainless Steel Tubular Head Types, Model DB-2 Series
16-552	June 1963	Celsius Temperature-Resistance Calibration Tables
16-711	July 1966	Mounting, Model ERB Recorder
16-716	July 1966	Operation, Model ERB Recorder
16-721	July 1966	Troubleshooting, Model ERB Recorder
16-722	December 1969	Replacement of Slide Wire Contact, Models ER and ERB Recorders
16-723		ERB Series Recorders, Range Change Procedures
16-730	January 1971	Alarm Contact Assemblies for Model ERB Recorders
16-772	April 1971	Amplifiers Schematics and Parts List, ERB and NRE-6 Series Recorders
16-787	October 1966	Model ERB 12-40 Recorder, Schematic Diagram
17-210	March 1953	Air Supply System
18-227	November 1971	Installation and Operation, Model 699 pH-to-Current Converter
18-228	October 1968	Servicing, Model 699 pH-to-Current Converter
18-367	April 1975	Model 63R Alarms, Style B
18-415	May 1965	Model 69TA-1 Current to Air Transducer, Style B and C
18-420	November 1968	Model 69TA-1 Current to Air Positioner
18-425	May 1966	Replacement of Force Coil, Model 69TA Transducers and Model 69PA Positioners
18-509	July 1971	Mounting, Rack Mounted Electronic Consotrol Instruments
18-510	September 1967	Model EH Shelf Installation
18-513	August 1967	Operating the Recording Parts, Model 6400H Recorder with Scan-Fold Chart Drive

<u>MI</u>	<u>Date</u>	<u>Title</u>
18-514	July 1967	Chart Illumination and Alarm Lights, Model 6400H Recorder
18-516	April 1974	Dual-Sprocket Scan-Fold Chart Drive, Series 6400H Recorders
18-520	January 1967	Model 6400H Recorders, Styles A, B, and C
18-521	June 1969	Servicing, Model 6400H Recorder
18-525	January 1975	Series 6400H-A Trend Recorders (Supplement to Instruction MI 18-511 or 18-520)
18-526	February 1968	Servicing, Model 6400H Trend Recorder
18-547	March 1971	Servicing, Model 67HF Controller Bypass, Style B
18-548	March 1967	Model 67HF Controller Bypass, Installation and Operation
18-645	September 1968	Model 694A Resistance to Current Converter, Style C
18-646	September 1968	Servicing, Model 694A Resistance to Current Converter
18-680	February 1969	Model 66K Integrator, Style C
18-681	June 1969	Servicing, Model 66K Integrator, Styles C and D
18-682	June 1971	Series 66KS Square Root Integrator, Style D
18-770	August 1970	Model 62HD DDC Backup Controller, Style C, Installation and Operation
18-771	April 1971	Model 62HD DDC Backup Controller, Style C, Servicing
18-775	August 1970	Model 67HD DDC Manual Backup Station, Style C, Installation and Operation
18-776	March 1971	Model 67HD DDC Manual Station, Style C, Servicing
18-790	March 1971	Model 67HD Type J DDC Manual Station, Style C, Servicing
19-210	July 1968	Model PA-106A Field Mounted Preamplifier, Part No. A2015KX
19-215	December 1970	Wiring Preamplifier A2020LA or PA-106A
19-260	January 1972	Model 99V Frequency Converter

<u>MI</u>	<u>Date</u>	<u>Title</u>
20-110	January 1969	Model E13DM Differential Pressure Transmitter, Installation and Operation
20-115	January 1969	Model E13DL Differential Pressure Transmitter
20-120	January 1969	Model E13DH Differential Pressure Transmitter
20-125	January 1969	Wiring, Series E10 Force-Balance Transmitters
20-132	September 1969	Liquid Flow Measurement, Series E13 Differential Pressure Transmitters
20-140	April 1975	Mechanical Servicing, Series E13 Differential Pressure Transmitters
20-143	October 1971	Disassembly of Force Motor Assembly, Series E10 Transmitters
20-145	January 1969	Electronic Servicing, Series E10 Force-Balance Transmitters
20-215		Model E11GM Pressure Transmitter
20-250	January 1973	Models 17BS and 17BT Buoyancy Level Transmitters
20-270	January 1972	Series E17D Liquid Level Transmitters
21-120	December 1973	Series 2800 Magnetic Flow Transmitters
21-190	February 1970	Signal Cable Preparation and Connections for Model 696A Magnetic Flow to Current Converter and Series 2800 Magnetic Flow Transmitter
21-211	September 1971	Model 696A Magnetic Flow-to-Current Converter, Styles B, C, and D
21-216	April 1972	Servicing, Series 696A Magnetic Flow-to-Current Converter, Style C
21-217	May 1973	Servicing, Series 696A Magnetic Flow-to-Current Converter, Style D
21-235	February 1971	Model 696A Automatic Zeroing, Model 696A-XXXX-Z0
22-137	February 1973	Anderson, Greenwood Three-Valve Bypass Manifold, Part B0152ME-316SS
22-310	November 1973	Model 13 Differential Pressure Transmitter, Installation and Operation
22-315		Model 15 Differential Pressure Transmitter, Installation and Operation

<u>MI</u>	<u>Date</u>	<u>Title</u>
22-320		Model 13H Differential Pressure Transmitter, Installation and Operation
22-330	November 1973	Integral Orifice Manifold Assembly, In-Line Type
22-331	November 1973	Integral Orifice Manifold Assembly, U-Bend Type
22-332	November 1973	Calibration, d/p Cell Transmitters with Integral Orifice Manifold Assembly
22-340	December 1973	Calibration-Model 13, 13H, or 15 Differential Pressure Transmitter
22-345	May 1974	Servicing, Model 13, 13H, or 15 Differential Pressure Transmitter
22-470	May 1974	Series 13F Liquid Level Transmitters
22-472	April 1974	Calibration and Servicing, Series 13F and 15F Liquid Level Transmitters

The following drawings are not referenced in this plan directly but may be helpful in locating components for laying away or reactivating. A set of these drawings should be available at the plant as part of the as-built documentation provided by the contractor.

Atlas Chemical Industries, Inc., Volunteer Army Ammunition Plant, TNT Line Number 4, 5, and 6 Process and Instrument Schematics:

- Drawing Number ACI-P-568-Z, Day Tank Farm
- Drawing Number ACI-P-569-X, Day Tank Farm
- Drawing Number ACI-P-570-W, After Sep, NITS 1A and 1B, Sep 1
- Drawing Number ACI-P-571-W, NITS 2-3A and 3B, Sep 2 and 3
- Drawing Number ACI-P-572-O, NITS 4 - 6, Sep 4 - 6
- Drawing Number ACI-P-573-Z, Acid Washer
- Drawing Number ACI-P-574-Y, Post Sellite Washer
- Drawing Number ACI-P-575-O, Settling Tank Area.

## SECTION 2 - LAYING AWAY THE CONTROL SYSTEM

### 2.1 GENERAL

#### 2.1.1 Layaway Philosophy

The general philosophy for storing control system components is to leave them in place with adequate protection to prevent damage. This approach has several advantages:

- It eliminates damage and losses caused during removal, transportation, and warehousing.
- It eliminates the problems caused by reinstalling incorrect equipment at a given location or reinstalling the correct equipment incorrectly.
- It reduces the tendency to appropriate various components for use elsewhere.

#### 2.1.2 Sequence for the Layaway Process

It is important that the layaway procedures dealing with control system components be coordinated with the layaway procedures for the process equipment and buildings. Many of the control system layaway procedures are predicated on the assumption that the process equipment has already been cleaned. In planning the overall work flow for layaway, the following is the sequence that should be used:

1. Drain all process lines and equipment of acids, TNT, and nitrobody, including all tubing to pressure and differential pressure transmitters.
2. Replace all orifice plates with metal gaskets.
3. Flush all process equipment until it is chemically neutral. After flushing the system with caustic and before flushing with water, service the differential pressure transmitters, Model E13D. See Paragraph 3.3.2.
4. Clean, preserve, and replace all orifice plates.
5. Drain hydraulic system.

6. Turn power off to all control system equipment.
7. Complete all layaway procedures for process control system elements except the converters in the Hydraulic Pump House.
8. Flush the hydraulic system to clean it, if required. Fill with preservative, circulate the preservative, then drain the hydraulic system.
9. Layaway the electronic equipment in the Hydraulic Pump House.

While layaway work is proceeding in the process buildings, assemble all the documentation required as part of the control house layaway.

## 2.2 GENERAL PROCEDURES FOR LAYAWAY

### 2.2.1 Unused Lines

The procedures for laying away process instrumentation are defined assuming the line has been used to make TNT. If a line has never been used, do not disassemble the instruments and valves to clean them. Leave valve packing in place. Remove any rust and apply preservatives as specified in the procedures.

### 2.2.2 Orifice Plates

Remove all orifice plates prior to flushing and cleaning the process lines and equipment. This will prevent contaminants remaining lodged in the pipe on the upstream side of the orifice. Clean the orifice plates, coat them with P-2, and replace them in the lines after they are flushed clean and dried.

### 2.2.3 Marking Control System Components

Place a piece of fluorescent orange or yellow tape in a conspicuous place on each component in the control system when all layaway procedures on it have been completed. Remove each piece of tape when all reactivation procedures have been completed. This will make it easier to make a visual check for components which have not yet been laid away or reactivated.

### 2.2.4 Order of Layaway Procedures

Since the process equipment will have been flushed clean before starting these procedures, the order of laying away the control system components makes no difference except for the E13D Differential Pressure Transmitters. (See Paragraph 2.1.2.) The order in which the procedures are listed on the checklists was chosen only to simplify finding the right procedure using the TAG number on the component.

### 2.2.5 Hydraulic Pump House Equipment

The electronic equipment in the Hydraulic Pump House/Relay Room will be preserved in place by closing the room and installing a dehumidifier and a heater. Power will be turned on to the electronics during the periodic maintenance at the Control House to drive out any moisture which may have accumulated. The dehumidifier should be

installed to drain outside the building. It should be large enough to maintain the humidity at 40 percent or lower. The heater should be thermostatically controlled to keep the temperature above 45°F.

Install a recording thermometer and humidistat which can be checked daily for performance of the humidifier and heater.

#### 2.2.6 Power to Field Equipment

Remove all power from field instruments prior to servicing. For read-only devices - thermocouples, D/P cells, level transmitters, etc. - this is done by removing the fuse in the rack behind the computer. For control valves this is done by removing the top plug from the 62 HD or 67 HD controller in the Line Panel in the Control Room.

#### 2.2.7 Desiccant

The amount of desiccant to be placed in designated instruments shall be determined in accordance with MIL-P-116F, Paragraph 3.6.6.

#### 2.2.8 Moisture-Proof Tape

All openings to the atmosphere in pneumatic instruments shall be sealed with tape in accordance with MIL-STD-107E, 14 June 1974, Appendix B, Paragraph 21.19.

#### 2.2.9 Hydraulic Oil System

All components in the hydraulic oil system shall be serviced only after the hydraulic oil has been drained from the system. Components shall be disassembled only so far as necessary to clean and apply preservatives to the external parts. All components in the hydraulic system will be reassembled in serviceable condition. If the hydraulic oil drained from the system was free of sludge, corrosion, and other foreign matter, preserve the system by filling with hydraulic preservative oil, P-15, circulate thoroughly, drain the oil, and close all openings. If the initial drain indicates contamination, fill with Solution A, circulate thoroughly until system is clean, drain completely, and preserve with P-15 as indicated above for an uncontaminated system.

### Solution A

One part lubricating oil, P-10, Type I, Grade 30, and nine parts cleaning solvent, P-D-680. (Refer to MIL-STD-107E, 14 June 1974, Paragraph 21.8.)

The cleaning solution, Solution A, should be saved when it is drained so it may be used for cleaning the hydraulic system in all lines.

#### 2.2.10 Filling With Dry Nitrogen

Many of the instruments having explosion-proof housings will be preserved in place by filling the housings with dry nitrogen. Clean, lubricate, and replace the O-ring seal between the instrument housing and the screw-on cover. Place a plastic tent over the cap and position the tent over the instrument. Fill the tent with a low-pressure supply of dry nitrogen to drive out the air and moisture; then screw the cap onto the instrument until it is firmly seated against the O-ring seal. The cap should be screwed on only as tight as can be done by hand; do not use a wrench of any kind.

#### 2.2.11 Instrument Air

While the CIL control system equipment is in the process of being laid away, take special precautions to assure that the 3-15 psia instrument air is as dry and free of dust as possible. Maintain the flow of this clean air until a line has been completely laid away. Before shutting off instrument air to a line, close all drain petcocks in the filters to prevent ambient air from seeping into the pneumatic system.

#### 2.2.12 Waste Disposal

All materials collected during layaway which are to be discarded will have the following disposition:

- Solids; burning ground
- Seal liquid; burning ground
- Acids; neutralizing pond
- All other liquids; red water system

#### 2.2.13 Protection From Weather and Dirt

Since control system components will be stored in place, each one must be protected from damage caused by weather and/or dirt. After each group of control system components which is located outdoors has been treated according to the procedures defined in Section 3, it will be wrapped with a plastic impregnated covering to exclude rain, snow, and dust. Refer to Paragraph 3.8.1.

Each group of control system components located inside a process building will be wrapped with a plastic sheet to exclude dirt and any moisture which might leak through the roof. Refer to Paragraph 3.8.8.

#### 2.2.14 Emergency Phone Numbers

Post the name, address, and phone numbers of service personnel for the air conditioning systems in the Central Control House and Hydraulic Pump Houses in a prominent place at each of the following locations:

- the Central Control House
- each Hydraulic Pump House
- the Central Security Station.

## 2.3 SPECIFIC PROCEDURES FOR LAYAWAY

### 2.3.1 Process Area Components

There are 35 unique types of components which are used to monitor and control the process. Each one of the approximately 334 control and monitoring points used by the computer control system contains one or more of these 35 components. The layaway process for each of the 35 components is specified in a procedure defined in Section 3 of this plan. Section 3 also contains procedures for items not directly associated with control such as bypass valves, pressure regulators, and recorders.

Appendix E contains a checklist defining each component in each control and monitoring loop in the line. The checklist is organized alphabetically in TAG number sequence for easy reference. It defines the procedure in Section 3 to follow for laying away the component. Be sure to check the fluid associated with a component so the correct procedure is followed. Initial each item on the checklist when its layaway procedure has been completed. Be sure to cover each group of components as defined in Paragraphs 3.8.1 or 3.8.8.

### 2.3.2 Central Control House

1. Turn off all power to field instruments and control valves. For the read-only loops, this is done by removing the fuses from the digital termination rack behind the computer. For instruments and valves associated with controllers in the line panel, kill power to the panel or remove the ac power plug from the controller.
2. Clean filters at the bottom of each cabinet in the computer room.
3. It is imperative that the operating contractor assemble a complete set of current data defining the settings of all instruments. This data will be assembled in TAG number sequence and placed in a notebook to be stored with the layaway plan. This data must include at least the following:
  - a. proportional band, derivative and reset settings for all 62 HD and 67 HD analog controllers

- b. calibration range of each instrument in instrument units; e.g., inches of H<sub>2</sub>O
  - c. measurement high and low values for each instrument in engineering units; e.g., pounds per hour (pph)
  - d. limit setting and direction for all alarm relays (Model 63R); e.g., 20 mA decreasing
  - e. setting of each Mercoid pressure and temperature switch. The temperature settings are particularly critical since they provided the fail-safe backup to dump the nitrators in the event of a temperature runaway.
4. Assemble all documentation which is required to load, start, and run the computer and the applications software. Much of this documentation is contained in Foxboro manuals. However, detailed copies of the applications software including the batch flow charts and complete data base listings are also required. The most up-to-date version of punched paper tapes associated with the system, including the various hardware diagnostic programs, should be clearly labeled and assembled in order, in trays. Any copies or older versions of the punched paper tapes should also be clearly labeled and stored in separate trays away from the up-to-date versions.
- Listings of all system and applications software shall be bound in clearly labeled hardware covers. These listings shall be stored in the computer room with the punched paper tapes.
- Duplicate copies of all punched paper tapes and all program listings will be made and stored in a dry, secure place away from the Central Control House.
5. Assemble all other documentation which has been collected by the operating contractor in relation to the control system, index it, and store one copy in the Central Control House. Store a second copy in a dry, secure place along with the computer tapes and listings. This documentation will include but not be

limited to such information as descriptions of control loop design and implementation, lists of process equipment components, and modifications to the system - both accomplished and planned.

6. Refer to Paragraphs 3.9.3 and 3.9.4 for procedures to prepare recorders for layaway.
7. Establish a Maintenance Log in a notebook to be kept at the Control House. Describe any repairs made to the equipment during the layaway process. This log will be updated by the Maintenance Contractor while the plant is in storage.

## SECTION 3 - PROCEDURES FOR PROCESS CONTROLS AND INSTRUMENTATION

### 3.1 VALVES

#### 3.1.1 Poppet Plug Valve, Type F45 and Type 5310

##### Reference Specifications:

- MI 12-240, July 1968, Three-Way Control Valves
- MI 12-235, July 1971, Models P25, P50, P110 Pneumatic Diaphragm Actuators

#### 3.1.1.1 Layaway Procedures

1. Close the block valve in the instrument air supply and disconnect the pneumatic fitting to the actuator. Immediately seal the pneumatic fittings with moisture-proof tape.
2. Disassemble the valve as described on page 2 of MI 12-240. Clean all parts with running water until a litmus test shows they are chemically neutral. Discard packing unless it is Teflon.
3. Inspect the plug and seat rings for a smooth machined finish. If either surface is not smooth, request a Foxboro field service engineer to inspect the valve to determine if anything should be replaced.
4. Lightly coat all internal parts with P-9 preservative.
5. Reassemble stem, lower flange and bonnet ready for operation.
6. Reassemble valve topworks fingertight without asbestos packing or gaskets.
7. Attach actuator and signal air line.
8. Clean all fingerprints and coat all exposed metal with P-2 preservative.

#### 3.1.1.2 Maintenance Procedures

None

### 3.1.1.3 Reactivation Procedures

1. Remove the actuator as described on page 1 of MI 12-240 under "Replacing Actuator". Replace the diaphragm and reassemble actuator.
2. Remove all P-2 preservative from metal parts.
3. Repack the valve as described in Instruction Sheet MI 12-214.
4. Reassemble the valve and replace the actuator. Reconnect the signal air line to the actuator.

### 3.1.2 Saunders Type Valves Type G2

#### Reference Specifications:

- MI 12-260, October 1963, Saunders Type Valves

#### 3.1.2.1 Layaway Procedures

1. Close block valve to instrument air supply and disconnect the air supply line from the actuator. Seal the air fittings with moisture-proof tape.
2. Remove the topworks as described in MI 12-260 under "Replacing the Diaphragm".
3. Discard the diaphragm and flush the valve hardware with water until a litmus test shows it is chemically neutral.
4. Dry all metal parts with compressed air and coat with P-9 preservative. Reassemble valve but do not include the diaphragm.
5. Reconnect the actuator and its signal air line.

#### 3.1.2.2 Maintenance Procedures

None

#### 3.1.2.3 Reactivation Procedures

1. Remove the actuator and replace its diaphragm.
2. Replace the diaphragm in the valve works as described on page 2 of MI 12-260.
3. Assemble the actuator to the valve and adjust operating pressure range as described in MI 12-260.

### 3.1.3 VI Control Valves

#### Reference Specifications

- MI 12-150, June 1974
- MI 12-210, Valve Installation
- MI 12-236, Series P Actuators
- MI 12-235, Models P25, P50, and P110 Pneumatic Diaphragm Actuators
- MI 12-340, September 1969, Type C Vernier Valvactor

#### 3.1.3.1 Layaway Procedures - Non-Hydraulic Service

1. Close block valve in pneumatic air supply line and disconnect air fittings from the P series actuator. Immediately seal the pneumatic fittings with moisture-proof tape.
2. Disassemble external valve parts as described on page 6 of MI 12-150.
3. Discard the felt wiper.
4. Wash all parts until a litmus test shows them to be chemically neutral.
5. Disassemble valve trim as described on page 7 of MI 12-150.
6. Discard seat gasket and bonnet gasket. Discard packing if it is filled asbestos. If the packing is V-Ring Teflon, keep it.
7. Repeat Step 4 for all valve trim parts.
8. Inspect the plug assembly at the end of the stem. (See drawings on page 8 of MI 12-150.) Also look down into the valve body still in the pipeline to inspect the seat ring. If either the seat ring or the plug assembly does not have a smooth-machined finish, request a Foxboro field service engineer to inspect the valve to determine if these parts need replacing.

9. Coat all internal parts with P-9 preservative. Reassemble the valve trim with no gaskets or asbestos packing. Insert the Teflon packing if the valve has it. This assembly should be done only fingertight since the valve will have to be disassembled again during reactivation.
10. Coat all external parts with P-2 preservative.

Note: If the valve body has to be removed for any reason, note the direction of the arrows on the casting which indicates the direction of fluid flow (see page 2 of MI 12-150). Be sure the valve body or its replacement is reinstalled the same way!

#### 3.1.3.2 Layaway - Hydraulic Service

1. Begin this procedure only after the hydraulic system has been drained and flushed clean as described in Paragraph 2.9 of this plan. Disassemble external valve parts only as required to clean and remove rust from all exposed metal surfaces. Refer to page 6 of MI 12-150.
2. Reassemble valve in working condition. Clean fingerprints from all exposed metal surfaces and coat lightly with P-2 preservative.
3. After all hydraulic valves have been laid away, clean and preserve the hydraulic system as described in Paragraph 2.9 of this layaway plan.

#### 3.1.3.3 Maintenance Procedures

None

#### 3.1.3.4 Reactivation Procedures

1. Remove actuator as directed on page 3 of MI 12-150 and page 2 of MI 12-235.
2. Replace the diaphragm in the actuator. See page 3 of MI 12-235.
3. Disassemble external valve parts and valve trim and clean off P-2 preservative. Reassemble with new gaskets and lubricants as directed in MI 12-150.
4. Reinstall the actuator and connect its signal air line.

### 3.1.4 V-4A Needle Valve

#### Reference Specifications:

- MI 12-225, January 1968, Needle, Stabilflo, V-Port, and Poppet Valves Used With Reversible Actuator
- MI 12-214, November 1963, Stem Packing for F-Coded Valves

#### 3.1.4.1 Layaway Procedures

1. Close block valve to instrument air supply line and disconnect the pneumatic line to the actuator. Seal pneumatic fittings with moisture-proof tape.
2. Remove valve trim and discard the packing.
3. If the valve service is not air, remove the valve from the line. Flush the valve body with water until a litmus test shows it is chemically neutral. Clean the mounting flanges and coat them with P-2 preservative. Fog the valve body with P-9 preservative and reinstall it in the line.
4. Clean rust, dirt, and chemicals from the valve trim. Coat the stem and plunger with P-9 preservative and reassemble valve trim fingertight and without packing.
5. Coat any exposed non-stainless steel metal with P-2 preservative.

#### 3.1.4.2 Maintenance Procedures

None

#### 3.1.4.3 Reactivation Procedures

1. Disassemble valve trim and remove all preservatives.
2. Reassemble valve trim with new packing. Refer to MI 12-214.
3. Remove valve from line and remove preservatives from mounting flanges.
4. Reinstall valve in line using new gaskets.

5. Replace the diaphragm in the actuator.
6. Connect a variable 3-15 psia air supply to the actuator. Cycle the pressure from 3 to 15 psi two or three times and visually verify that the valve is working by watching the stem move.

### 3.1.5 Ball Valve Model 9000

#### Reference Specifications:

- MI 12-280, April 1970, Ball Valve With P Series Actuator
- MI 12-235, P-Series Actuators

#### 3.1.5.1 Layaway Procedures

1. Close block valve in instrument air supply.
2. Disconnect air supply to actuator to bleed off any residual air pressure. Immediately cover the air fittings with moisture-proof tape.
3. Remove valve from the line. Be sure to mark it so it can be reinstalled in correct position.
4. Flush the flanges with water until a litmus test shows they are chemically neutral.
5. If the valve service is in water or steam, blow the inside of the valve dry with compressed air and fog with P-9 preservative.
6. If the valve service is other than water or steam, remove the ball and seats, stem and stem seal as described on page 4 of MI 12-340. Flush all internal parts with water until a litmus test shows they are chemically neutral. Coat all internal parts with P-9 preservative and reassemble fingertight without the seals.
7. Remove and clean the linkage and coupling. Coat linkage and coupling with P-2 preservative. BE SURE TO NOTE THE POSITIONS OF THE BALL, THE LINKAGE SHAFTS AND THE ACTUATOR BEFORE DISASSEMBLING. THEY MUST BE REASSEMBLED IN EXACTLY THE SAME RELATIONSHIP OR THE VALVE ACTION WILL BE REVERSED.

8. If the stem and stem seal were removed as part of Step 6, do not replace the seal when reassembling the valve and linkage. Reassemble the valve fingertight.
9. Reinstall valve in the line.
10. Clean off any fingerprints and coat exposed metal with P-2 preservative.

#### 3.1.5.2 Maintenance Procedures

None

#### 3.1.5.3 Reactivation Procedures

1. Remove the actuator and replace its diaphragm according to MI 12-235.
2. If the valve is used for other than steam or water, remove the valve from the line and clean off all P-2 preservative.
3. Remove the body insert from the valve and reassemble with a new seal. See page 5 of MI 12-280.
4. Reinstall valve in line. Be sure you get it back the same way it was.
5. Replace the stem seal, and reassemble the topworks as described on page 4 of MI 12-280.
6. Replace the wire filters on the air connections and reconnect the air supply.

### 3.1.6 Anderson, Greenwood 3-Valve Bypass Manifold

- Part Number B0152ME, 316 Stainless Steel
- Part Number B0152MC, Cadmium Plated Steel

#### Reference Specification:

- MI 22-137, February 1973

#### 3.1.6.1 Layaway Procedures

1. Remove the manifold from the pressure transmitter after the transmitter has been flushed with water.
2. Remove the three valve stems. Flush the body of the manifold and the three valve stems with water until a litmus test shows they are chemically neutral.
3. Remove and discard packing material around stems. Discard the gaskets at the manifold inlets and outlets.
4. *Reassemble the manifold fingertight with no valve packing or gaskets.*
5. After the pressure transmitter associated with the manifold has been serviced, reassemble the transmitter, manifold and pressure connection. Reinstall the assembly in the process equipment.

#### 3.1.6.2 Maintenance Procedures

None

#### 3.1.6.3 Reactivation Procedures

1. Remove manifold from pressure transmitter.
2. Repack valve stems.
3. Reattach manifold to pressure transmitter and connect pressure connection assemblies attached to the orifice flange.

### 3.1.7 Model X53, X55, Skinner Solenoid Valves

#### Reference Specifications

- D5.5.1, March 1969, Maintenance and Cleaning Instructions (Appendix A-5)

#### 3.1.7.1 Layaway Procedures

1. Clean the exterior of the valve to remove all dirt and other contaminants.
2. Spray or brush on P-9 preservative.
3. Close valve in pneumatic supply line.

#### 3.1.7.2 Maintenance Procedures

None

#### 3.1.7.3 Reactivation Procedures

1. Replace the rubber parts in the valve.
2. Open the valve in the pneumatic line to supply air to the valve.
3. Actuate the valve from the operator's console in the control house to verify it is operating. If the valve fails to operate, verify that the actuating signal from the control house is reaching the valve. When it is, refer to Skinner Bulletin, D5.5.1, and follow the instructions for inspection and reassembly.

3.1.8 3-Valve Bypass Manifold Model BM-SS-3V

Reference Specifications:

None

3.1.8.1 Layaway Procedures

1. After instrument has been disconnected from the manifold, make sure all three valves are open to drain.
2. Remove the U-shaped stainless steel tubing connected to the bypass valve.
3. Flush the U-tube and the three valves with hot water to clean tubing.
4. Remove stem from each valve and flush stem, Teflon packing, and internal part of valve body with hot water to remove contaminants. Check with litmus paper to assure all parts are chemically neutral.
5. Coat all parts with P-9 preservative, and reassemble all valves fingertight with no packing.
6. Replace the U-shaped SS tubing in the manifold.

3.1.8.2 Maintenance Procedures

None

3.1.8.3 Reactivation Procedures

Repack valve stems.

## 3.2 LEVEL CONTROLS

### 3.2.1 Liquid Level Transmitters Series E17D

#### Reference Specifications:

- MI 20-270, January 1972, Series E17D Transmitters
- MI 20-125, External Wiring (10-50 mA output)
- MI 20-145, Electronic Servicing (10-50 mA output)
- MI 20-143, Disassembly of Force Motor Assembly Series E10 Transmitters

#### 3.2.1.1 Layaway Procedures

1. Make sure that tank on which the transmitter is mounted is empty after being flushed with caustic and clear water.
2. Remove transmitter from tank. Flush mounting flange and transmitter surface exposed to tank contents with clear water until a litmus test shows they are chemically neutral. Do the same for the flange on the tank.
3. Coat the transmitter surface exposed to the tank liquid with P-2 and let dry.
4. When the P-2 is dry on the transmitter surface, cover the tank flange with plastic sheet, push the transmitter back into place, and reinsert mounting bolts. If the original mounting bolts and nuts were carbon steel, replace them with stainless steel parts.
5. Place dry desiccant in base of transmitter topworks and fill cap with nitrogen.
6. Place moisture-proof tape over the zero adjustment screw.

#### 3.2.1.2 Maintenance Procedures

None

### 3.2.1.3 Reactivation Procedures

1. Make a calibration setup as described on page 7 of MI 20-270.
2. Calibrate the transmitter as described beginning on page 8 of MI 20-270.
3. If transmitter cannot be successfully calibrated, service the electronic top-works using the corresponding specification. Do a static alignment as described on page 12 of MI 20-270. Repeat the calibration procedure.
4. If the transmitter cannot be successfully calibrated in Step 3, replace the force motor referring to MI 20-143. Repeat the calibration.
5. If the transmitter cannot be successfully calibrated in Step 4, replace the diaphragm referring to page 9 of MI 20-270. Repeat the calibration.
6. If the transmitter cannot be calibrated in Step 5, discard it and calibrate a new unit.
7. Install the transmitter on the tank and make the reference adjustment described on page 6 of MI 20-270.

### 3.2.2 Magnetrol Level Switches TF-63

#### Reference Specifications:

- Magnetrol Bulletin 42-608
- Magnetrol Bulletin 42-680
- Magnetrol Bulletin 44-602.1, December 1974, Instruction Manual and Parts List

#### 3.2.2.1 Layaway Procedures

1. Disconnect float and arm from connecting rod to the magnetic sleeve. If float and rod are not severely corroded, wash them with water until a litmus test shows them to be chemically neutral. Dry them with compressed air, coat with P-2 preservative, identify them with a plastic coated label containing the TAG identification and store in the hydraulic pump house. If the float and rod are severely corroded, discard them and order replacement parts.
2. Remove the switch from its mounting flange on the side of the tank. Flush all flanges and surfaces exposed to process chemicals until a litmus test shows they are chemically neutral.
3. Remove all rust. Clean and then dry exposed metallic surfaces with compressed air and coat with P-2 preservative.
4. Place a sheet of polyethylene plastic over the mounting flange, push the level switch back into position, and replace the mounting bolts fingertight.

#### 3.2.2.2 Maintenance Procedures

None

3.2.2.3 Reactivation Procedures

1. Remove the switch from its mounting flange and remove all preservatives.
2. Remount the switch with new gaskets.
3. Reconnect the float and connecting rod assembly to the magnetic sleeve.

### 3.2.3 Mercoïd Liquid Level Controls

#### Reference Specifications:

- Mercoïd Bulletin Number 0-420A, Series 301
- Mercoïd Bulletin Number 0-409A, Series 401

#### 3.2.3.1 Layaway Procedures

Do not service this control until the tank on which it is mounted has been drained and decontaminated with a clear water flushing.

1. Remove the control from the tank being careful not to damage the float assembly which is suspended into the tank.
2. Flush the float assembly and underside of the control to remove any concentrated contaminants.
3. Disassemble the float assembly and remove the insert in the armature tube.
4. Flush all components, including the interior of the armature tube until a litmus test shows they are chemically neutral.
5. Blow all parts dry with compressed air.
6. Coat the inside of the armature tube and its insert with P-9 preservative.
7. Reassemble the float assembly; clean all exposed metal of fingerprints and coat all exposed non-stainless steel parts with P-2 preservative.
8. Place desiccant bag inside top enclosure and fill the enclosure with dry nitrogen.
9. Reinstall control in tank and reconnect the electrical circuits.

#### 3.2.3.2 Maintenance Procedures

None

### 3.2.3.3 Reactivation Procedures

1. Remove the desiccant bag from the top enclosure.
2. Remove the mounting bolts in the flange and raise the control far enough to expose the float.
3. Actuate the control by either pushing or pulling the float upward with a known force equal to the buoyancy of the float in the fluid being controlled. Verify that the contact closure is made by monitoring the test at the operator's console in the control house. If the force applied is not sufficient to move the float, remove the control from the tank and thoroughly clean it to reduce the friction. If the float moves but the contact closure is not detected at the computer, remove the top enclosure and visually check the operation of the mercury switch. If the mercury switch moves properly, check the circuit back to the computer before replacing the mercury switch. If the switch will not move, replace the switch magnets or the complete switching assembly.

### 3.3 PRESSURE TRANSMITTERS AND CONTROLS

#### 3.3.1 Pressure Transmitter Model E11GM

##### Reference Specifications:

- MI 20-215, October 1971, Model E11GM
- MI 20-145, January 1969, Electronic Servicing, Series E10 Force-Balance Transmitters

##### 3.3.1.1 Layaway Procedures

1. Remove side of transmitter to expose the diaphragm. Fog the area lightly with preservative P-10, and replace the side of the transmitter.
2. Remove the strainer plug from the bottom of the transmitter. (Refer to page 1 of MI 20-215 for schematic drawing.)
3. Bleed dry nitrogen into transmitter through the strainer plug opening to drive out any air or water. Be sure the small diameter tube used to do this has a flange which will prevent inserting it too far into the transmitter and damaging the flexure.
4. Replace the strainer plug and seal the opening with tape. Refer to Paragraph 2.8.
5. Place desiccant bag inside top of transmitter. Refer to Paragraph 2.7.
6. Cover the zero adjustment with moisture-proof tape.
7. Fill the cap with nitrogen and replace. Refer to Paragraph 2.10.

##### 3.3.1.2 Maintenance Procedures

None

### 3.3.1.3 Reactivation Procedures

1. Assemble a calibration facility as shown on page 6 of MI 20-215.
2. Connect sensor to the calibration setup and do the calibration procedure described on page 8 of MI 20-215. If unit will not calibrate properly, refer to MI 20-145 for directions to service the force balance transmitter. Repeat the calibration procedures.
3. If the sensor cannot be calibrated under Step 2, disassemble and replace the diaphragm. Reassemble and calibrate.
4. If the unit cannot be calibrated in Step 3, discard it and get a new replacement.
5. Install the sensor on its mounting bracket in the process area and reconnect the electric cable to the topworks.
6. When ready to operate the sensor, make the reference adjustment described on page 4 of MI 20-215.

### 3.3.2 Differential Pressure Transmitter, Model E13D

#### Reference Specifications:

- MI 20-110, January 1969, Model E13DM
- MI 20-115, January 1969, Model E13DL
- MI 20-120, January 1969, Model E13DH
- MI 20-125, January 1969, Series E10 Force Balance Transmitters
- MI 20-140, April 1975, Mechanical Servicing Series E13 Differential Pressure Transmitters
- MI 20-132, September 1969, Installation

Each of the three models of differential pressure transmitters have the same general internal design. The primary difference among the three models is the operating pressure range. Because of this difference, the diaphragms and diaphragm housings have a different design. The procedures to be followed are the same for each of the three models.

#### 3.3.2.1 Layaway Procedures (for transmitters used with fluids other than air or water)

**DANGER! WEAR PROTECTIVE CLOTHING AND FACE MASK. THE TRANSMITTER MAY CONTAIN DANGEROUS LIQUIDS, AND THEY MAY BE UNDER PRESSURE.**

**DO NOT ATTEMPT TO DRAIN AND REMOVE THE TRANSMITTER WHILE THE PROCESS LINE IS PRESSURIZED. THE TRANSMITTER SHOULD BE SERVICED ONLY AFTER THE PROCESS EQUIPMENT HAS BEEN FLUSHED WITH CAUSTIC AND BEFORE IT IS FLUSHED WITH CLEAR WATER.**

1. Close the two pressure connection valves and open the bypass valve.
2. Open the vent and drain plugs on both sides of the transmitter body. Catch fluids in a stainless steel bucket. Dispose of the fluids. See Paragraph 2.12.

3. Close vents and drains and remove transmitter and valve from the mounting location. Be sure to label electrical connections before disconnecting so they may be correctly reassembled.
4. Flush both the high and low pressure sides with clear water.
5. Referring to MI 20-140, April 1975, disassemble the sensor body and valve manifold and remove the diaphragm. Dip all internal transmitter parts and the transmitter body in a mild caustic solution to neutralize any remaining acid which was not flushed by the water. Discard the coarse screen filters and associated gaskets at the pressure inlets.
6. Flush all internal parts and the transmitter and valve manifold body with running clear water until a litmus test shows they are neutral.
7. Spray internal parts of sensor with P-9 and reassemble the sensor ready for line operation. Be sure to install new coarse screen filters and gaskets at the pressure inlets. Refer to page 4 of MI 20-140. Be sure drain and vent plugs are closed.
8. Place desiccant bag inside topworks and fill with dry nitrogen. Cover the zero adjust screw with moisture-resistant tape.
9. Insert plastic plugs in valve manifold inlets on both the high and low pressure sides.
10. Reinstall the transmitter on its mounting bracket, and reconnect electrical leads.
11. Remove the tubing to the orifice flange and discard it.

3.3.2.2 Layaway Procedures (for transmitters used with air or water)

1. For transmitters in water service, open the high and low pressure manifold valves, close the bypass, and drain the transmitter by opening all drain and vent plugs.
2. Disconnect the tubing to the orifice flange at the manifold valves.

3. Remove the diaphragm capsule. See MI 20-140.
4. Using dry compressed air, blow the inside of the transmitter dry.
5. Fog the inside of the transmitter with P-9. Fog the inside of the manifold valve, too.
6. Clean fingerprints from the diaphragm capsule. Spray it with P-9 and reassemble the transmitter. Be sure to spray the casting which was removed to expose the diaphragm.
7. Insert plastic plugs or blind nipples in both pressure inlets of the valve manifold. Close all drain and vent plugs tightly.
8. Tape tubing from orifice flanges closed with moisture-proof tape.
9. Place desiccant in bottom of topworks and fill cap with nitrogen. See Paragraphs 2.7 and 2.10 of this plan.
10. Seal zero adjustment with moisture-proof tape.

#### 3.3.2.3 Maintenance Procedures

None

#### 3.3.2.4 Reactivation Procedures

1. Connect the differential pressure transmitter to a calibration setup as shown on page 3 of MI 20-140. Calibrate the transmitter according to the procedures stated on the same page.
2. If the transmitter cannot be correctly calibrated, refer to MI 20-145, page 3, for the operational check of the electronics. When correct operation of the electronics has been verified, repeat the calibration check of the transmitter.
3. If the unit still cannot be calibrated and all topworks including the force motor assembly have been checked, disassemble the transmitter and replace the diaphragm. Refer to MI 20-140.

4. Once the transmitter has been calibrated, mount it with its mounting bracket next to the orifice flange. Install new stainless steel tubing from the bypass valve to the pressure inlets. Refer to MI 20-132, September 1969, Installation. Differential pressure transmitters used with strong nitric acid should be sealed from the acid by filling the sensor lines with Flourinet. (See FT-5, FT-6, FT-7, FT-8, and FT-9.)
5. Connect the wiring to the transmitter assembly. Refer to MI 20-125.
6. When ready to run the process, adjust the zero and put the sensor into operation as described on page 4 of MI 20-120.

### 3.3.3 Liquid Level Transmitters Series 13F

#### Reference Specifications:

- MI 22-470, Installation and Operation
- MI 22-472, Calibration and Servicing

#### 3.3.3.1 Layaway Procedures

These procedures should be done after the process equipment has been completely decontaminated and blown dry.

1. Disconnect the pneumatic lines to the transmitter and seal the fittings immediately with moisture-proof tape.
2. Remove the bolts attaching the mounting flange to the tank being measured.
3. Remove the transmitter and discard the flange gasket. Flush both flanges with water until a litmus test shows them to be chemically neutral. Do the same with the portion of the transmitter exposed to process fluids.
4. Blow all parts dry with compressed air and coat with P-9 preservative.
5. Place plastic sheet loosely over the mounting flange and push the transmitter through into position. Tighten flange bolts only fingertight.
6. Remove cover from topworks and replace the gasket.
7. Purge the topworks with low pressure dry nitrogen and fill cap with dry nitrogen. Insert desiccant into topworks, lower cap into gasket, and tighten mounting screws.

#### 3.3.3.2 Maintenance Procedures

None

#### 3.3.3.3 Reactivation Procedures

1. Disconnect all process fittings and dismount transmitter from tank, and discard plastic sheet.
2. Calibrate the transmitter as described in MI 22-472, April 1974. If unit cannot be calibrated, do the appropriate servicing described in MI 22-472.
3. Install the calibrated unit with a new gasket, and reconnect the air supply line.
4. Make the zero adjustment as described on page 7 of MI 22-470.

### 3.3.4 Mercoïd Series "D" Pressure Controls

- DAH-21, 403 Stainless Steel Bourdon Tube in Explosion Proof Plain Case
- DAH-31, Brass Bourdon Tube in Explosion Proof Plain Case
- DAW-33, Brass Bourdon Tube in Watertight or Weather Resistant Flanged Case

Reference Specification:

- Mercoïd Bulletin Number 0-0118R, Mercoïd Series "D" Pressure Controls

#### 3.3.4.1 Layaway Procedures

1. Disconnect the pressure fitting at the bottom of the case to allow any trapped fluid to drain out.
2. Dismount the case. If it is the DAH-21 control, it has been exposed to nitrobody and acid fumes which must be neutralized before it can be preserved. Flush the DAH-21 bourdon tube with water until a litmus test of the drained fluid shows it is chemically neutral.
3. When the bourdon tube has dried, fill it with preservative P-9 and then drain.
4. Cap the pressure fitting in the bottom of the case with a blind nipple. Remount the case in its correct location.
5. Leave any tubing which connects to the instrument in place and seal it with moisture-proof tape. If the tubing needs to be replaced during reactivation, it will simplify the replacement process to have the old tubing on hand.
6. Clean the case to remove all dirt and/or other contaminants.
7. Insert a desiccant bag in the case and close the front cover.
8. Record the high and low limit settings in TAG number sequence for each instrument. This record will be used during reactivation to check and calibrate the instrument.

#### 3.3.4.2 Maintenance Procedures

None

#### 3.3.4.3 Reactivation Procedures

1. Remove the desiccant bag from the case.
2. Check the mounting of the case to assure it is vertical and level.
3. Using the limit values recorded during layaway, check the correct operation and setting of the instrument with a calibrated variable pressure source connected to the pressure fitting in the bottom of the case. Use an air source if the instrument service is in air; use a water source for all other instruments.
4. If the instrument cannot be calibrated and set to operate repeatedly, replace it with a new instrument and repeat the calibration.

### 3.4 TEMPERATURE SENSORS

#### 3.4.1 Dynatherm Resistance Bulbs Model DB-2 Series

##### Reference Specifications:

- MI 16-124, June 1964, Dynatherm Resistance Bulbs, Model DB-2 Series
- MI 16-552, June 1963, Celsius Temperature-Resistance Calibration Tables

##### 3.4.1.1 Layaway Procedures

Remove the cover from the Crouse-Hinds head and paint the terminals with varnish. Replace the cover.

##### 3.4.1.2 Maintenance Procedures

None

##### 3.4.1.3 Reactivation Procedures

1. Refer to MI 16-552 and check the calibration curve of the instrument and its associated converter.
2. Insert the resistance bulb into a calibrated, temperature controlled oil bath and verify that the temperature response is correct by monitoring the display on the operator's console in the control house.

### 3.4.2 DAH-35 Mercoid Thermal Limit Switch

#### Reference Specification:

- Bulletin 0-419, Installation Instructions, Mercoid Series D Remote Bulb Temperature Controls

#### 3.4.2.1 Layaway Procedures

1. Clean the exterior of the explosion proof enclosure to remove all contaminants and dirt.
2. Record the high and low limit settings of each instrument in TAG number sequence. This record will be used to check and calibrate the instrument during reactivation.
3. Insert a desiccant bag inside the instrument and replace cover.

#### 3.4.2.2 Maintenance Procedures

None

#### 3.4.2.3 Reactivation Procedures

1. Remove the desiccant bag.
2. Remove the temperature bulb from its thermal well and insert in a temperature controlled oil bath. Vary the temperature of the oil bath through the critical operating range. Verify through the operator's console at the control house that the switch opens and closes at the correct temperatures. Refer to the settings recorded during Step 2 of the layaway. If the switch operates at incorrect temperatures that are within a few degrees of the correct setting, adjust the settings in the explosion proof case. If the shift in the operating temperature is excessive or if the thermal bulb is suspect, replace the thermal bulb and recalibrate the switch.

If the switch still cannot be set correctly, replace it with a new unit.

3. Inspect the thermal well to assure it is still serviceable and has no condensed liquids in it before reinserting the temperature bulb.

### 3.5 CONVERTERS AND ALARMS

#### 3.5.1 Alarms Model 63R

Reference Specification:

- MI 18-367

##### 3.5.1.1 Layaway Procedure

Record the alarm level setting in a list arranged alphabetically by TAG number.

##### 3.5.1.2 Maintenance Procedures

None

##### 3.5.1.3 Reactivation Procedures

1. Write down the color code for the connections to the termination panel. Then disconnect the wires to terminals marked +, -, NC, C, and NO. Referring to page 3 of MI 18-367, connect a current source, a milliammeter and an ohmmeter as shown for adjusting setpoint. Vary the current from 10 to 50 mA and verify that the alarm is operating by watching the ohmmeter change from infinity to zero. If the alarm will not work, turn off power, remove connections to L1, L2, and GND screws, remove the alarm and throw it away. Install a new alarm, and connect power source to terminals L1, L2, and GND. Repeat Step 1.
2. Once the alarm is verified as working, check the alarm level required and adjust the setpoint so the alarm triggers at this level. Refer to the alphabetic listing recorded during layaway for the correct setting.

### 3.5.2 Resistance-to-Current Converter Model 694A, Style C

#### Reference Specification:

- MI 18-645, September 1968

#### 3.5.2.1 Layaway Procedures

None. This converter is located in the hydraulic pump house. It will be preserved in place by controlling the humidity in the pump house.

#### 3.5.2.2 Maintenance Procedures

1. Turn on electrical power to all converters for the duration of the periodic maintenance program.
2. At the end of the periodic maintenance, turn off power to the converters.

#### 3.5.2.3 Reactivation Procedures

Perform the calibration procedure described on pages 3 and 4 of MI 18-645. If the converter will not calibrate properly, refer to MI 18-646 for servicing instructions.

### 3.5.3 Magnetic Flow-to-Current Converter, Model 696A

#### Reference Specifications:

- MI 21-211, September 1971, Model 696A Magnetic-to-Flow Converter
- MI 21-216, April 1972, Servicing, Style C
- MI 21-217, May 1973, Servicing, Style D
- MI 21-190, February 1970, Signal Cable Preparation and Connections

#### 3.5.3.1 Layaway Procedures

1. Place a desiccant bag inside the converter. Be sure to place it so it is not in contact with any electrical circuits which could short out when power is turned on.
2. Replace the gasket on the cover plate and attach the cover. The converter will be stored in place in the hydraulic pump house by controlling the humidity. Refer to Paragraph 2.5 of this layaway plan.

#### 3.5.3.2 Maintenance Procedures

1. Turn on electrical power to all converters for the duration of the periodic maintenance program.
2. At the end of the periodic maintenance, turn off power to the converters.

#### 3.5.3.3 Reactivation Procedures

1. Determine if the Model 696A Magnetic Flow-to-Current Converter is operating correctly. To do this, refer to MI 21-216, page 2, for a Style C converter or to MI 21-217 for a Style D converter and do the operational check.

2. When the converter is operating correctly, calibrate it according to the procedures defined on page 5 of MI 21-211. Note: Ignore the note which says to set the calibrated 0 to 10.00 mV manual dial. The calibration on the dial, if it was included as an option, may have shifted during storage.
3. When the converter is calibrated, do the startup procedure specified on page 4 of MI 21-211.

### 3.5.4 pH-to-Current Converter Model 699

#### Reference Specifications:

- MI 18-227, November 1971, Installation and Operation, Model 699 pH-to-Current Converter
- MI 18-228, October 1968, Servicing, Model 699 pH-to-Current Converter

#### 3.5.4.1 Layaway Procedures

Place a desiccant bag inside door to converter. This converter will be preserved in place by controlling the humidity in the hydraulic pump room.

#### 3.5.4.2 Maintenance Procedures

1. Turn on electrical power to all converters for the duration of the periodic maintenance program.
2. At the end of the periodic maintenance, turn off power to the converters.

#### 3.5.4.3 Reactivation Procedures

1. Remove the desiccant bag inside the converter case.
2. Perform the calibration procedure specified beginning on page 6 of MI 12-227. If the calibration cannot be completed successfully, refer to MI 18-228 for the necessary servicing instructions.
3. After the process equipment is ready for a water test, install the pH-electrodes and complete their connection to the converter.

### 3.5.5 Frequency Converter, Model 99V

#### Reference Specification:

- MI 18-260, January 1972, Model 99V Frequency Converter

#### 3.5.5.1 Layaway Procedures

None. This converter is located in the hydraulic pump house. It will be preserved in place by controlling the humidity in the pump house.

#### 3.5.5.2 Maintenance Procedures

1. Turn on electrical power to all converters for the duration of the periodic maintenance program.
2. At the end of the periodic maintenance, turn off power to the converters.

#### 3.5.5.3 Reactivation Procedures

Perform the operational check described on page 4 of MI 19-260. If servicing is necessary, refer to page 6 of MI 19-260. When the converter is operating correctly, calibrate it as described on page 5 of MI 19-260.

### 3.6 FLOW AND SPEED

#### 3.6.1 Flow Switch, McDonnell and Miller Model FS-7-SE

Reference Specifications:

None

##### 3.6.1.1 Layaway Procedures

None. This flow switch is welded in place to maintain its position relative to the flow. It is impossible to replace the paddle if it has corroded because of the way the switch is mounted into its fitting. It is impossible to inspect the paddle for corrosion.

##### 3.6.1.2 Maintenance Procedures

None

##### 3.6.1.3 Reactivation Procedures

Fabricate a new assembly and install it in the line. Use a new flow switch.

### 3.6.2 Magnetic Flow Transmitters Series 2800

#### Reference Specifications:

- MI 21-120, December 1973, Series 2800 Magnetic Flow Transmitters
- MI 21-211, September 1971, Model 696A Magnetic Flow-to-Current Converter
- MI 21-216, April 1972, Servicing, Style C
- MI 21-217, May 1973, Servicing, Style D
- MI 21-190, February 1970, Signal Cable Preparation and Connections

#### 3.6.2.1 Layaway Procedures

1. Refer to page 6 of MI 21-120. Remove cover plate from transmitter and paint a thin coat of varnish on terminals and wires.
2. Close the cover plate tightly.
3. Clean the outside of the case to remove all dirt and/or contaminants. There are no internal parts in the transmitter which must be serviced during layaway. Flushing the process equipment with caustic and then clear water will clean the transmitter.

#### 3.6.2.2 Maintenance Procedures

None

#### 3.6.2.3 Reactivation Procedures

None

### 3.6.3 Magnetic Pickup Electro Model 3070

#### Reference Specifications:

- 52.106, June 1965, Operating Instructions
- 52.065B, March 1965, Magnetic Pickup Handbook

#### 3.6.3.1 Layaway Procedures

None

#### 3.6.3.2 Maintenance Procedures

None

#### 3.6.3.3 Reactivation Procedures

1. Reactivate the 99 V converter associated with this pickup.
2. During the water test of the complete system, verify that the pickup is providing an output to the converter. If it is not, replace the pickup with a new one.

### 3.7 POSITIONERS AND POSITION INDICATORS

#### 3.7.1 Microswitch 4EX-1, EX-AR, EXD-AR

Reference Specifications:

None

##### 3.7.1.1 Layaway Procedures

1. Clean the exterior of the switch including the roller arm.
2. Spray or brush on P-9 preservative and wrap the switch in plastic.

##### 3.7.1.2 Maintenance Procedures

None

##### 3.7.1.3 Reactivation Procedures

Activate the switch manually and verify its closure at the operator's console in the control house. If the switch closure does not register in the control house, open the switch housing and check the switch closure again using an ohmmeter. If the ohmmeter verifies the switch is not operating replace the switching unit, the actuator, the internal lever, and/or the spring, as required.

If the switch will still not operate, replace it with a new unit.

### 3.7.2 Current-to-Air Positioner Model 69PA-1

#### Reference Specifications:

- MI 18-420, November 1968, Model 69PA-1 Current-to-Air Positioner
- MI 18-425, May 1966, Replacement of Force Coil Model 69TA and 69PA Positioners

#### 3.7.2.1 Layaway Procedures

1. Disconnect the linkage between the positioner and the valve or process equipment. Clean the linkage and apply P-2 preservative.
2. Clean the outside of the positioner case to remove any condensed residue or dirt.
3. Remount the linkage.
4. Place desiccant bag inside positioner.
5. Close the block valve in the instrument air supply line and seal all openings in the positioner with moisture-proof tape.

#### 3.7.2.2 Maintenance Procedures

None

#### 3.7.2.3 Reactivation Procedures

1. Remove desiccant bag.
2. Refer to page 4 of MI 18-420. Remove and clean the reducing tube and replace the two o-rings on the reducing tube.
3. Refer to MI 11-490, -491, or -493 to clean or replace the control relay.
4. Do the calibration procedure specified on page 6 of MI 18-420. If the calibration cannot be successfully completed, replace the force coil as described in MI 18-425. Repeat calibration procedure.

### 3.7.3 Current-to-Air Transducer, Model 69TA-1

#### Reference Specifications:

- MI 18-415, May 1965, Model 69TA-1 Current-to-Air Transducer
- MI 18-425, May 1966, Replacement of Force Coil Model 69TA and 69PA Positioners

#### 3.7.3.1 Layaway Procedures

1. Clean the outside of the transducer case to remove any condensed residue or dirt.
2. Place desiccant bag inside transducer.
3. Close the block valve in the instrument air supply line and seal all openings in the positioner case with moisture-proof tape.

#### 3.7.3.2 Maintenance Procedures

None

#### 3.7.3.3 Reactivation Procedures

1. Remove the desiccant bag.
2. Refer to page 4 of MI 18-415. Remove and clean the reducing tube and replace the two o-rings on the reducing tube.
3. Refer to MI 11-490, 491, or 493 to clean or replace the control relay.
4. Do the calibration procedure specified on page 4 of MI 18-415. If the calibration cannot be successfully completed, replace the force coil as described in MI 18-425. Repeat the calibration procedure.

### 3.7.4 Position Transmitter Type CP

#### Reference Specification:

- MI 14-132, February 1971

#### 3.7.4.1 Layaway Procedures

1. Check the reducing tube as described on page 6 of MI 14-132. Clean it if it is plugged.
2. Replace the fine wire mesh filters in all air connections, reconnect air lines and shut the block valve.
3. Remove and clean linkage connected to the process equipment. Coat it with P-2 preservative.
4. Clean the exterior of the case to remove any condensed contaminants and/or dirt.
5. Seal all openings in the case with moisture-proof tape.
6. Reconnect linkage to process equipment.

#### 3.7.4.2 Maintenance Procedures

None

#### 3.7.4.3 Reactivation Procedures

1. Calibrate the transmitter as described under Transmitter Operating Adjustments beginning on page 4 of MI 14-132.
2. Replace cover gasket before reassembling.
3. Remove linkage, remove the P-2 preservative, and reinstall.

### 3.7.5 Type C Vernier Valvactor

#### Reference Specifications:

- MI 12-340, September 1968, Type C Vernier Valvactor, Yoke Mounted

#### 3.7.5.1 Layaway Procedures

1. Remove the linkage to the valve, clean the linkage to be chemically neutral, and coat with P-2 preservative.
2. Place desiccant inside valvactor case and replace the cover.
3. Clean outside of valvactor case to remove all dirt and/or condensed residue.
4. Shutoff block valve to instrument air supply. Then seal vent hole on front of case with moisture-proof tape.
5. Reconnect linkage to valve after the layaway procedures for the valve have been done.

#### 3.7.5.2 Maintenance Procedures

None

#### 3.7.5.3 Reactivation Procedures

1. Remove the desiccant from inside the case.
2. Remove the sealing tape from the air vent in the front of the case.
3. Replace the wiremesh or cartridge filters in the air connections. See page 8 of MI 12-340.
4. After the associated valve has been reactivated, check the operating adjustments described beginning on page 6 of MI 12-340

### 3.8 MISCELLANEOUS

#### 3.8.1 Outdoor Storage of Valves and Transmitters

Reference Specifications:

None

##### 3.8.1.1 Layaway Procedures

After all procedures have been done to clean and apply appropriate preservatives, the complete assembly shall be protected from moisture and dirt by shrouding it with vinyl-coated nylon fabric conforming to MIL-C-43006 or nylon reinforced laminated plastic sheet conforming to L-P-00524 having strength at least equal to Griffolyn Type 45. Be sure to secure the shroud with wire or tape so it will remain in place until the unit is reactivated. Shrouds shall be draped in a manner to completely cover the component and arranged to avoid the formation of water pockets. All sharp corners and projections shall be padded or cushioned before shrouding.

##### 3.8.1.2 Maintenance Procedures

Inspect the plastic covering shrouding the component. Replace the covering if it has deteriorated or been damaged so that the intent of the Layaway Procedure is no longer met.

##### 3.8.1.3 Reactivation Procedures

None

### 3.8.2 pH Electrodes

#### Part Numbers:

- Q0104AN, Q0104AP, Measuring Electrodes
- Q0104AT, Q0104AW, Reference Electrodes

#### Reference Specifications:

- MI 14-240, November 1968
- MI 14-241, July 1970
- MI 18-227, November 1971
- Installation and Operation Model 699 pH-to-Current Converter

#### 3.8.2.1 Layaway Procedures

Disconnect the electrode from its transmitter, remove the electrode from its holder, and discard the electrode.

#### 3.8.2.2 Maintenance Procedures

None

#### 3.8.2.3 Reactivation Procedures

Procure and install new electrodes. Refer to MI 14-240 and 14-241, page 3, for installation instructions. Refer to MI 18-227, Installation and Operation of Model 699 pH-to-Current Converter for wiring procedures. This procedure should be the last to be done before the plant is restarted with a water check.

### 3.8.3 Buoyancy Level Transmitters Models 17BS and 17BT

#### Reference Specifications:

- MI 20-250, January 1973, Model E17B
- MI 20-145, Electronic Servicing (10-50 mA)
- MI 20-142, Mechanical Topworks Servicing

#### 3.8.3.1 Layaway Procedures

1. Disconnect the displacer from the end of the force arm. Rinse the displacer in a mild caustic to neutralize any residual acids; then flush it with clear water until a litmus test shows it is chemically neutral.
2. Label the displacer with the TAG number assigned to the transmitter and store the displacer in the Hydraulic Pump House.
3. Remove the transmitter from its mounting by removing the bolts connecting it to the mounting flange.
4. Flush the process side of the transmitter flange and the diaphragm seal with clear water until a litmus test shows they are chemically neutral.
5. Apply P-2 preservative to the transmitter surface exposed to the inside of the tank.
6. Flush the mounting flange on the tank with water until a litmus test shows it is chemically neutral. Dry the flange surface and apply P-9 preservative.
7. Place desiccant bag inside the topworks and fill the topworks with dry nitrogen. Refer to Paragraphs 2.7 and 2.10 of this plan.
8. Apply P-9 preservative to the flange of the transmitter and remount it in the process tank. When remounting, replace any carbon steel nuts and bolts with stainless steel parts.

### 3.8.3.2 Maintenance Procedures

None

### 3.8.3.3 Reactivation Procedures

1. Remove the P-2 preservative from the transmitter surfaces inside the tank.
2. Do a bench calibration of the transmitter following instructions beginning on page 6 of MI 20-250.
3. If the calibration cannot be completed satisfactorily, refer to MI 20-146 or MI 20-145 for Electronics Topworks Servicing, and MI 20-142 for Mechanical Topworks Servicing.
4. Install transmitter and displacer in the process equipment according to instructions on pages 2 and 4 of MI 20-250.
5. With the transmitter in operation, adjust the reference as described on page 5 of MI 20-250.

3.8.4 Field Mounted Preamplifier Model PA-106A

Part Number A2015KX

Reference Specifications:

- MI 19-210, July 1968

3.8.4.1 Layaway Procedures

None

3.8.4.2 Maintenance Procedures

None

3.8.4.3 Reactivation Procedures

Refer to MI 19-210, page 2, and perform operational check. If unit is non-operational, remove it from the line, throw it away, and replace it with a new one.

### 3.8.5 Air Filter

#### Reference Specifications:

- MI 14-705, May 1952, Supply and Transmission Piping

#### 3.8.5.1 Layaway Procedures

Drain accumulated fluids by opening the petcock at the bottom of the filter. Leave the petcock closed for storage.

#### 3.8.5.2 Maintenance Procedures

Open the petcock on the bottom of each air filter to drain accumulated water which may have condensed in the system. When water no longer drips from the petcock, close it.

#### 3.8.5.3 Reactivation Procedures

Replace the filter element as described on page 2 of MI 14-705.

### 3.8.6 Fixed Pressure Filter Regulator

Part Number B-110-ZM

Reference Specification:

- MI 11-152, April 1959

#### 3.8.6.1 Layaway Procedures

1. Loosen drain plug (Item 7 in Figure B3586) to drain sump.
2. Blow pressurized air through supply.
3. Replace filter (Item 6).
4. Tighten drain plug.
5. Leave unit in place.

#### 3.8.6.2 Maintenance Procedures - Periodic

1. Loosen drain plug (7) and leave open until all drainage stops.
2. Tighten drain plug.
3. Replace filters (6).

#### 3.8.6.3 Reactivation Procedures

1. Loosen drain Plug (7).
2. Install new filters (6).
3. Tighten drain plug.

### 3.8.7 Type 67 Supply Regulator and Type 67 FR Filter-Regulator

Part Number B110-SX and B110-XR

Reference Specification:

- MI 11-155, May 1960, Type 67 Supply Regulator

#### 3.8.7.1 Layaway Procedures

1. Do not change valve setting.
2. Open drain plug until all liquids have been drained.
3. If type 67FR filter regulator, remove drain sump (15 in Figure B3068), and replace filter element.
4. Replace sump.

#### 3.8.7.2 Maintenance Procedures

1. Do not change valve setting.
2. Open sump drain valve (6).
3. If Type 67FR filter regulator, remove drain sump (15 in Figure B3068), and replace filter element.
4. Replace sump.

#### 3.8.7.3 Reactivation Procedures

1. Replace diaphragm according to description on page 2 of reference specification.
2. Replace filter element.

### 3.8.8 Indoor Storage of Valves and Transmitters

#### Reference Specification:

- Federal L-P-378 Plastic Sheet and Strip Thin Gauge, Polyolefin

#### 3.8.8.1 Layaway Procedures

Use this procedure only on components located within the N & P Building. After all components in a group have been laid away, shroud the components with plastic sheet meeting the standards of the reference specification. The purpose of the shroud is to exclude airborne dust and dirt from the preserved equipment. Therefore, fasten the plastic tightly with tape on all sides to form a closed envelop surrounding the equipment. Arrange the plastic to eliminate any traps that could collect any moisture that might condense.

#### 3.8.8.2 Maintenance Procedures

Inspect the plastic covering and tape seal to assure the covering remains an effective dust barrier. Replace any coverings which may have been damaged.

### 3.9 RECORDERS AND CONTROLLERS

#### 3.9.1 DDC Manual Backup Station Model 62 HD

##### Reference Specifications:

- MI 18-770, August 1970, Installation and Servicing
- MI 18-771, March 1971, Servicing

##### 3.9.1.1 Layaway Procedures

Record the proportional band, reset, derivative, high limit, low limits and the position of the reversing switch in a table organized alphabetically by TAG number.

##### 3.9.1.2 Maintenance Procedures

Refer to MI 18-771 and perform all operational checks specified in Section I, pages 1 through 4. Refer to Section III, Troubleshooting, if some malfunction occurs.

##### 3.9.1.3 Reactivation Procedures

1. Perform all operational checks specified in MI 18-771. Refer to Section III, Troubleshooting, if some malfunction occurs.
2. Once controller is operating, perform the calibration procedures specified in Section II of 18-770.
3. Refer to alphabetic listing recorded during layaway to set the proper values for proportional band, derivative, reset high and low limits, and reverse switch.

### 3.9.2 DDC Backup Controller Model 67 HD

#### Reference Specifications:

- MI 18-775, August 1970, Installation and Operations
- MI 18-776, April 1971, Servicing

#### 3.9.2.1 Layaway Procedures

Record the high and low limit and load settings in alphabetic TAG number sequence.

#### 3.9.2.2 Maintenance Procedures

Refer to MI 18-776 and perform all operational checks specified in Section I, pages 1 through 4. Refer to Section III, Troubleshooting, if some malfunction occurs.

#### 3.9.2.3 Reactivation Procedures

1. Perform all operational checks specified in MI 18-776. Refer to Section III, Troubleshooting, if some malfunction occurs.
2. Once controller is operating, perform the calibration procedures specified in Section II of MI 18-776.
3. Refer to alphabetic listing recorded in layaway to set in the proper values for high and low limits and load.

### 3.9.3 Recorders Model 6400H

#### Reference Specifications:

- MI 18-520, January 1967, Model 6400H Recorders, Styles A, B, and C
- MI 18-525, January 1975, Series 6400H-A Trend Recorders, Supplement to MI 18-520

#### 3.9.3.1 Layaway Procedures

1. Remove the ink capsules. Partially fill pressurizing bulb with water and force water through ink supply until pens are clear.
2. Remove pen tips and clean under running water. See page 4 of MI 18-520. Replace pen tips in recorder.

#### 3.9.3.2 Maintenance Procedures

None

#### 3.9.3.3 Reactivation Procedures

Refer to MI 18-520 and 18-525 to insert ink into recorder and to calibrate it.

### 3.9.4 Model ERB Recorder

#### Reference Specifications

- MI 16-716, July 1966, Operation Model ERB Recorder
- MI 16-721, July 1966, Troubleshooting Model ERB Recorder

#### 3.9.4.1 Layaway Procedures

1. Remove felt inking pad.
2. Clean pen tips in alcohol.
3. Lightly oil all points as specified on pages 6 and 7 in MI 16-716.
4. Clean the slidewire.
5. Drain selector switch oil supply.

#### 3.9.4.2 Maintenance Procedures

None

#### 3.9.4.3 Reactivation Procedures

1. Refer to MI 16-716 and follow directions to load ink and oil.
2. Follow procedures beginning on page 3 of MI 16-716 to adjust and calibrate the recorder. Refer to MI 16-721, Troubleshooting Model ERB Recorders, if the recorder does not operate properly.

## SECTION 4 - MAINTENANCE

### 4.1 DAILY MAINTENANCE

#### 4.1.1 Environmental Control Systems

At least once a day check the environmental control systems in the Central Control House and the Hydraulic Pump Houses to assure temperature and humidity are being maintained within the prescribed limits. Temperature and humidity in the Central Control House should be monitored at all times with a recording device similar to the one purchased at the Volunteer Plant. This device continuously records temperature and humidity and closes a relay contact when either exceeds a preset limit. This device should be wired to sound an alarm at the central plant security station which will be continuously manned.

The temperature in the Hydraulic Pump Houses shall be maintained above 45°F and the humidity below 45 percent. The recording devices for temperature and humidity should also have alarm points at the central plant security station.

Whenever a temperature or humidity alarm is activated, manually verify the cause of the alarm. For all valid alarms contact the appropriate service personnel to request immediate maintenance.

#### 4.1.2 Protective Coverings

Check the protective plastic impregnated coverings over all control system components located in:

- settling tank area
- day tank area.

If any coverings come loose in the wind or are otherwise damaged, replace them. Refer to Paragraph 3.8.1. Record the date and TAG number for all coverings replaced so the yearly maintenance crew can give special attention to coverings which are repeatedly replaced.

## 4.2 YEARLY MAINTENANCE

### 4.2.1 Process Equipment Areas

Check all plastic and plastic impregnated coverings over all groups of control components. Replace as necessary. Refer to Paragraphs 3.8.1.2 and 3.8.8.2. Check the records maintained by the plant security force to determine which coverings had to be replaced. If any were repeatedly damaged, take particular care to protect these coverings to eliminate or at least minimize future damage.

### 4.2.2 Central Control House

The maintenance procedures defined here will provide first a quick check of the operational capability of the digital system and then a more detailed evaluation. The detailed digital diagnostics can be run while the individual analog controllers are being checked.

1. Check helium pressure in both drums and re-pressurize if necessary. Refer to DDC drum maintenance manual.
2. Check and adjust all analog and digital dc power supplies. Refer to appropriate power supply maintenance manual.
3. Check and replace all faulty lamps in the analog and digital subsystem and console.
4. Refer to the Maintenance Log and complete any outstanding repairs.
5. Load all control programs into the primary computer (Tracks 1 through 377). Load all supervisory programs into the backup computer (Tracks 400 through 777).
6. Start both computers and do a backdate to transfer control program to the supervisory computer.
7. Check operating load ripple of all dc power supplies.
8. On each DDC line test loops LOX059, LOX060, LOX061, and LOX062 where X is the line number.

- a. At the line panel change setpoint manually with the bat handle. Since the output is fed back to the input in these loops, the measurement should track the setpoint. If it does track, the basic functions of the controller are working.
- b. Put each loop "ON SCAN" from the engineer's console. Console typer should log the action. Change the setpoint manually, and verify that the measurement displayed on the operator's console also changes. If it does not, run diagnostics to check the A/D converter and panel.
- c. Place the bat handle for each of these controllers in the digital position. Console typer should log the action. If the green light comes on, the contact input module is working correctly. If the green light goes out, the digital output module is working correctly.
- d. From the operator's console, switch to the backup computer. If the switch is made successfully, the communications module and the drum read/write circuits are working.

These procedures will test the operation of the basic computer modules. They will not check the operation of each of the digital and analog input to the system. That will be done in validating the system during reactivation.

9. Check all analog controllers. While checking the analog controllers, run the various diagnostic programs as per Item 10. Use jumper plug, Foxboro Part Number N0139SA, to test each controller. Unplug top cable from the back of the controller and plug in the jumper plug. This feeds the output back to the input. With the bat handle in the manual position, change the setpoint. If both meters change and track each other, the controller is working. If so, replace the top cable and proceed to the next controller. If not, refer to MI 18-771 for the 62 HD controllers and MI 18-776 for the 67 HD controllers, and perform all operational checks specified in Section I, pages 1 through 4. Refer to Section III, Troubleshooting, to correct the malfunction.

10. The tests specified under Item 8 will give a quick evaluation of system capability. The various diagnostic programs listed here will give a more thorough evaluation of system performance. The programs are listed in the recommended order of execution. (Note that the CPU and drum diagnostics need not be run if the computer has been continuously in use during the previous year of storage.)

All programs labeled (MAINDEC) are Digital Equipment Corporation programs and their documentation is contained in a green Foxboro notebook labeled MAINDEC Diagnostic Programs. All other programs were developed by Foxboro and are documented informally with memos. A collection of this documentation should be available with the diagnostic tapes. If it is not, or if any descriptions are missing, contact Mr. Frank Cogdell in Foxboro, Mass., Phone: (617) 543-8750.

- a. Instruction Test 1 (MAINDEC)

This is a diagnostic program for testing the AND, TAD, and OPERATE instructions of the 8I CPU.

- b. Instruction Test 2 (MAINDEC)

This is a diagnostic program for testing indirect addressing, autoindexing, and program interrupt facility.

- c. Instruction Test - Part 3A (EAE) (MAINDEC)

This program is a test of the extended arithmetic element. The following instructions are tested: MQL, MQA, SHL, LSR, ASR, NMI, SCA, SCL.

- d. Instruction Test - Part 3B (EAE) (MAINDEC)

This diagnostic program tests the MUL and DVI instructions in both ION and IOF modes.

e. Extended Memory Checkerboard (MAINDEC)

This diagnostic program is designed to provide worst case half-select noise conditions in order to determine the operational status of core memory. The program exercises basic and extended memory.

f. Extended Memory Address Test (MAINDEC)

This diagnostic program tests all of basic as well as extended memory not occupied by the program to ensure that each location can be uniquely addressed.

g. Extended Memory Parity Checkerboard (MAINDEC)

This program is designed to provide worst case half-select noise conditions in the memory parity bit plane.

h. Memory Power On-Off Test (MAINDEC)

This program is a memory data validity test to be used after a simulated power failure.

i. Extended Memory Control Test (MAINDEC)

This program tests the extended memory control logic for proper operation.

j. Random ISZ Test (MAINDEC)

This diagnostic program tests the ISZ instruction.

k. Random JMP Test (MAINDEC)

This diagnostic program tests the JMP instruction.

l. Random JMP-JMS Test (MAINDEC)

This diagnostic program tests the JMS instruction.

m. KP81/KR01 Power Fail Test (MAINDEC)

This diagnostic is a complete test of the PDP-8I power fail option.

n. KW8I Real Time Clock Test (MAINDEC)

This diagnostic program is designed to test all IOT and DATA transfer instructions used in the M708 clock control and M709 clock counter.

o. Foxboro I/O Module Tests

Teletype Tests - sub-tests are:

- Echo keyboard
- Line test
- Rotate pattern test.

p. Foxboro I/O Module Tests

Reader/Punch Test

This program set generates a test tape and verifies it on the high speed paper tape reader.

q. Magnetic Drum Assembly - Drum Test II

Sub-tests are tests 1 through 7. Run this test on only one drum at a time. Then update or backdate the image from one drum to the other before testing the second drum since this test destroys the drum image.

r. Input/Output Subsystem

Note: Prior to executing any I/O diagnostics, simulated DDC computer OP SYS failures should be initiated followed by backdate and restart to ensure that the SUPV computer is able to acquire the FOXSLO data bus and successfully run the DDC OP SYS.

- Foxboro I/O Module Tests

Analog input (A/D) test

This test series thoroughly checks the analog to digital converter and analog multiplexer as well as the analog data amplifiers.

- Foxboro I/O Module Tests

  - Valve control module tests

    - This test series drives selected DM or DAM control stations' outputs up or down through their full current range. Select loops LOX059, LOX060, LOX061, and LOX062, where X is the line number.

- Foxboro I/O Module Tests

  - Operator's console test

    - This test series affords visual feedback to operate initiated console functions to thoroughly qualify the operator data entry/display panels and the engineer tuning/display panel.

- Foxboro I/O Module Tests

  - Selectric typer test

    - Sub-tests are line test and pyramid pattern test.

- Dex Communication Module Test

    - This program extensively exercises the com-mod data break and interrupt logic.

11. Check the following non-electronic items associated with the computer:
  - a. Blower filters in the CPU and I/O racks  
Remove, clean, and reinstall the filters; then vacuum clean the complete blower assembly.
  - b. ASR and KSR teletypes  
Do preventive maintenance. To be done by qualified teletype serviceman.
  - c. IBM Selectric typers  
Do preventive maintenance. To be done by qualified IBM serviceman.
  - d. Paper tape punch  
Replace the oil.
  - e. Muffin fans in CPU's  
Inspect and replace if not free-turning.
12. Once all diagnostic programs have been run, all maintenance procedures have been completed, and all repairs have been made, turn off power to the line panels, control console, both computers, and the converters in the hydraulic pump house.
13. Update the maintenance log with descriptions of all repairs which have been made. If any failures were found which could not be corrected for lack of parts, describe the failure and the steps taken to obtain the necessary parts.

## SECTION 5 - REACTIVATION

The control system can be reactivated by taking the following steps:

1. Refer to the checklist of all control loops in Appendix E and do the corresponding reactivation procedures defined in Section 3.
2. Perform all maintenance functions in the Central Control House as defined under Paragraph 4.2.2.
3. Once the computer is operating, use it to validate each digital and analog input through the operator's console as specified in individual reactivation procedures.
4. As each actuator or control valve is reactivated, validate its operation by activating it from the operator's console and observing the reaction in the field equipment.
5. When all components of the system have been validated, load the applications software and do a water test with the complete system. This water test was defined and used to startup Line 4 at VAAP. A copy of this water test is included in Appendix C. A full-size version of the Water Test Plan including its check sheets should be included with the documentation assembled in the control room.

## SECTION 6 - RECOMMENDED SPARE PARTS

### 6.1 PARTS FOR FIELD COMPONENTS

This section lists the spare parts required to reactivate the field components. These should be procured at the time of reactivation.

#### 6.1.1 V1 Valves

- Bonnet gasket                      1 per valve
- Felt wiper                            1 per valve
- Teflon V-Rings                      1 set per 3 valves

Number of V1 Valves per line:

<u>Size</u>	<u>Number (VAAP Line 1)</u>	<u>Number (All Other Lines)</u>
1/2"	43	43
3/4"	2	2
1"	39	39
2"	8	8
3"	6	6

#### 6.1.2 V-4A Valves

- Felt wiper                            1 per valve
- Teflon V-Rings                      1 set per 3 valves
- Teflon wiper                        1 per 3 valves
- Spring                                1 per 3 valves

Number of V-4A valves per line:

<u>Size</u>	<u>Number (VAAP Line 1)</u>	<u>Number (All Other Lines)</u>
1/2"	14	14
3/4"	1	1
1"	4	0

AD-A046 082

COMPUTER SCIENCES CORP FALLS CHURCH VA  
LAYAWAY PLAN FOR DIRECT DIGITAL CONTROL (DDC) SYSTEMS ON THE CO--ETC(U)  
OCT 75

F/G 19/1

DAAA21-75-C-0244

NL

UNCLASSIFIED

CSC/SD-75/4137

2 OF 3  
ADA  
046082



6.1.3 F-45 Valves and Model 5310 Valves

- Felt wiper 1 per valve
- Teflon V-Rings 1 set per 3 valves
- Teflon wiper 1 per 3 valves
- Spring 1 per 3 valves

Number of F-45 valves in VAAP Line 1: 5 (size = 3/4")

Number of Model 5310 VAAP Lines 4, 5, 6: 5 each (size = 3/4")

Number of Model 5310 JAAP Lines 4, 5, 6: 5 each (size = 3/4")

6.1.4 V900 Valves

- Seat 1 pair per 5 valves
- Seal 1 per valve
- Stem seal 1 per valve

Number of V9000 valves per line:

<u>Size</u>	<u>Number</u>
1/2"	5
3/4"	22
1"	15
1-1/2"	9

6.1.5 Saunders G2 Valve

- Teflon diaphragm 1 per valve

Number of Saunders valves per line:

<u>Size</u>	<u>Number</u>
1"	2

6.1.6 P Series Actuators

- Diaphragm 1 per actuator

Number of actuators per line:

<u>Model</u>	<u>Number</u>
P25	29
P50	100
P110	13

6.1.7 X53, X55 Skinner Electric Solenoids

- Rubber parts replacement kit - 1 per valve

Number of valves per line:

<u>Model</u>	<u>Number</u>
X53	123
X55	8

6.1.8 Air Set B110XR

- Diaphragm 1 per air set
- Wire mesh strainer 1 per air set

Number of air sets per line: 61

6.1.9 Current-to-Air Positioner Model 69PA-1

- Reducing tube O-Rings 2 per transducer
- Cartridge type filters 2 per positioner
- Wire mesh filter 1 per positioner
- Force motor 1 per 8 positioners
- Control relay 1 per 8 positioners

Number of positioners per line: 24

6.1.10 Current-to-Air Transducer, Model 69TA-1

- Reducing tube O-Rings 2 per transducer
- Force motor 1 per 6 transducers
- Control relay 1 per 6 transducers

Number of transducers per line: 30

6.1.11 Microswitch Model 4EX1, EX-AR, EXD-AR

- Switching unit, Part Number  
DT-2R4-B6                      10 (for 4EX1 and EXD-AR)  
BZ-2R-P1                        5 (for EX-AR)
- Actuator, Part Number  
6PA5-EX                         1 per 3 switches
- Internal lever, Part Number  
33PA1-EX                        1 per 3 switches
- Spring, Part Number  
33PA6-EX                        1 per 4EX1 and EXD-AR  
33PA7-EX                        1 per EX-AR

Number of switches per line: 56

6.1.12 Level Transmitters, Model 13FA

- Control relay                      1 per 3 transmitters
- Diaphragm with gaskets        1 per transmitter
- Feedback O-Ring                1 per transmitter
- Nozzle O-Ring                    1 per transmitter

Number of transmitters per line: 3

6.1.13 Buoyancy Level Transmitter, Model E17BT

- O-Ring (for the cap)            1 per transmitter
- Mounting gasket                1 per transmitter
- 2 oz. tube flexible sealer      1 per transmitter

Number of transmitters per line: 4

6.1.14 Series E10 Transmitters

- Amplifier (Part N0143SY)      1 per 5 transmitters
- Detector (Part N0141LY)       1 per 5 transmitters

- Feedback coil 1 per 5 transmitters
- O-Ring for sealing cap 1 per transmitter

Number of E10 transmitters per line: 66

6.1.15 Liquid Level Transmitters, Series E17D

- Diaphragm capsule 1 per transmitter

Number of Transmitters per line:

<u>Model</u>	<u>Number</u>
E17DL	5
E17DM	14

6.1.16 Pressure Transmitter, Model E11GM

- Bellows capsule 1 per transmitter
- Strainer plug 1 per transmitter

Number of transmitters per line: 6

6.1.17 Differential Pressure Transmitters, Series E13D

- Diaphragm capsule with gaskets 1 per transmitter
- Coarse screen filters and gaskets 2 per transmitter

Number of transmitters per line:

<u>Model</u>	<u>Number</u>
E13DH	2
E13DL	6
E13DM	28

6.1.18 McDonnel and Miller Flow Switch, Model FS-7-SE

- Switches 4 complete switches per line

6.1.19 Mercoid Pressure Switch, Models DAH-21 and DAH-31

- Pressure Switch Complete Pressure Switch, Model DAH-21-103  
Range 26S - 2 per line

(There are 6 pressure ranges represented among the 18 pressure switches in each line. Rather than stock a complete range of spares, procure these switches from Mercoid as required.)

6.1.20 Mercoid Temperature Switch, Model DAH-35

- Model DAH-35-103, Range 7-2 per line
- Model DAH-35-103, Range 2-2 per line
- Model DAH-35-103, Range 6-2 per line
- Bulb Number 2 6 per line

(There are 25 Model DAH-35 Temperature Switches in each line. All use Bulb Number 2 as the sensing element. There are approximately an equal number of switches in each of three temperature ranges.)

6.1.21 Mercoid Level Switch, Model 401E and Model 301E

- Mercury switches 2 for Model 401E per line; 1 for Model 301E  
per line

6.1.22 Magnetrol Level Control, Model TF-63

- DPS-1, Code S104 DPDT  
Mercury switch Mechanism 2 per line
- Housing gasket 1 per controller

Number of controls per line: 8

6.1.23 Magnetic Flow-to-Current Converter, Model 696A

- Seal gasket for converter cover (1 seal needed for layaway; one for reactivation) 2 per converter
- Model 8120 Magnetic Flow Calibrator (calibrated with Bureau of Standards references) 1

Number of converters per line: 4

6.1.24 pH Electrodes

- Part Number Q0104AP Measuring Electrode with 20 foot integral leads 4 per line
- Part Number Q0104AW Reference Electrode with 20 foot integral leads 4 per line

## 6.2 PARTS FOR CONTROL HOUSE ELECTRONIC EQUIPMENT

The spare parts recommended for the control system when it is in use are listed on the following pages. During the maintenance period, the stock of these parts should be maintained at the minimum level in the storage area located in the Central Control House with at least one of each on hand. At the beginning of any reactivation effort, the stock should be increased to the maximum level.

If a user is found to keep the computer continuously running and maintained during the maintenance years, it will be his responsibility to keep and restock the spare parts required for the computer and its peripherals.

STOCK NUMBER	LOCATION		UI	ITEM DESCRIPTION	E	T	MAX QTY	MIN QTY	ON HAND	REP	ON ORDER	P.O.	THIS YEAR TOTAL ISSUED	DEMAND	TOTAL ON HAND VALUE
	BRD	SFC													
73-0001	DDC	01	003	FA LAMP,C396AMW*DCU STATUS-DIALC			25	12	25						5.00
73-0002	DDC	01	004	FA LAMP UNIT,C396ANA*DRUM			2	1	2						4.50
73-0003	DDC	01	005	FA LOCKOUT SWITCH, C326ATI			1		1						3.25
73-0004	DDC	01	006	FA DRIVER LAMP, TRANSISTOR			10	5	10						17.50
73-0005	DDC	01	007	FA SWITCH,RESTART,C3003CM,46-101			1		1						4.50
73-0006	DDC	01	008	EA HELIUM BOTTLE, V3000 PN			1		1						68.00
73-0007	DDC	01	009	EA DETECTOR,C3201R-PCR-60 HZ			1		1						270.00
73-0008	DDC	01	009	EA EXTENDER CARD,C3201MS,PCR			1		1						175.00
73-0009	DDC	01	010	EA AMP WRITE,C3201ME, PCR			1		1						445.00
73-0010	DDC	01	011	EA CLOCK,GEN,C3201 MF, PCR			1		1						335.00
73-0011	DDC	01	012	EA BOARD, PC, C4201MS			1		1						235.00
73-0012	DDC	01	013	EA GATE, C3201MM, PCR-DDC			1		1						130.00
73-0013	DDC	01	014	EA DECODE MATRIX, C3201MK			1		1						230.00
73-0014	DDC	01	015	EA CIRCUIT DELAY,C3201ML,PCR,			1		1						325.00
73-0015	DDC	01	016	EA TERMINATOR LINE, C3201NM-PCR			1		1						125.00
73-0016	DDC	01	017	EA AMPLIFIER X,C3201Y, PCR			1		1						465.00
73-0017	DDC	01	018	EA AMPLIFIER Y,C3201Z, PCR			1		1						405.00
73-0018	DDC	01	019	EA INVERTER,POSITIVE LOGIC C3202			1		1						295.00
73-0019	DDC	01	020	EA SPLY DRUM POWER,C340RBY,18/12			1		1						1,000.00
73-0020	DDC	01	020	EA BOARD, PRINTED CIRC, C021			3		3						540.00
73-0021	DDC	01	021	FA BOARD, PRINTED CIRC, C020			2		2						250.00
73-0022	DDC	01	022	FA BOARD, P.C, V300RMS, C221			3		3						216.00
73-0023	DDC	01	023	FA BOARD, P.C, G22R, V300RNT			3		3						255.00
73-0024	DDC	01	024	EA BOARD, P.C, V300RNX, G624			2		2						68.00
73-0025	DDC	01	025	EA BOARD, P.C, V300RNX, G695			1		1						41.00
73-0026	DDC	01	026	FA BOARD, P.C, V300RNY, G813R			1		1						100.00
73-0027	DDC	01	027	FA BOARD, P.C, V300RNY, GP26			1		1						110.00
73-0028	DDC	01	028	FA BOARD, P.C, V300RPK, M113			3		3						87.00
73-0029	DDC	01	029	FA BOARD, P.C, V300RPI, M115			2		2						150.99
73-0030	DDC	01	030	FA BOARD, P.C, V300RPM, M117			3		3						87.00
73-0031	DDC	01	031	FA BOARD, P.C, V300RPA, M119			1		1						33.00
73-0032	DDC	01	032	FA BOARD, P.C, V300RPN, M160			2		2						108.00
73-0033	DDC	01	033	FA BOARD, P.C, V300RPP, M162			2		2						190.00
73-0034	DDC	01	034	FA BOARD, P.C, V300RPR, M216			3		3						216.00
73-0035	DDC	01	035	FA BOARD, P.C, V300RPS, M220			2		2						420.00
73-0036	DDC	01	036	FA BOARD, P.C, V300RP7, M302			1		1						71.00
73-0037	DDC	01	037	FA BOARD, P.C, V300RPW, M310			3		3						270.00
73-0038	DDC	01	038	FA BOARD, P.C, V300RPX, M360			2		2						210.00
73-0039	DDC	01	039	FA BOARD, P.C, V300RBY, M452			1		1						67.00
73-0040	DDC	01	040	FA BOARD, P.C, V300RZ, M501			1		1						41.00
73-0041	DDC	01	041	FA BOARD, P.C, V300R7A, M516			2		2						134.00
73-0042	DDC	01	042	FA BOARD, P.C, V300R8, M617			2		2						88.00
73-0043	DDC	01	043	EA BOARD, PRINTED CIRC, M661			3		3						73.50
73-0044	DDC	01	044	EA BOARD, P.C, V300R7E, M660			2		2						82.00
73-0045	DDC	01	045	EA BOARD, P.C, V300R8E, M700			1		1						130.00
73-0046	DDC	01	046	FA BOARD, PRINTED CIRC, M703			1		1						725.00
73-0047	DDC	01	047	FA BOARD, P.C, V300R8K, M706			1		1						220.00
73-0048	DDC	01	048	EA BOARD, P.C, V300R8L, M708			1		1						255.00
73-0049	DDC	01	049	EA BOARD, P.C, V300R8M, M709			1		1						290.00
73-0050	DDC	01	050	FA BOARD, P.C, V300R8P, M720			1		1						290.00
73-0051	DDC	01	051	FA BOARD, P.C, V300R8P, M720			1		1						47.00
73-0052	DDC	01	052	EA GEN,FOX TOP,P/C RD,V300RLY F1			1		1						165.00
73-0053	DDC	01	053	EA DECODER,FOX INT, P/C RD,V3008			1		1						130.00
73-0054	DDC	01	054	EA BOARD,EXTENDER,36 PIN,V3008TE			2		2						74.00
73-0055	DDC	01	055	EA BOARD, P.C, V3007NW, W076			2		2						62.00
COMMODITY TOTAL															
VALUE LAST MONTH															
VALUE THIS MONTH															
VALUE OF E ITEMS TM															

STOCK NUMBER	LOCATION		UI	ITEM DESCRIPTION	E	T	UNIT VALUE	MAX. QTY.	MIN. QTY.	ON HAND	REP.	ON ORDER	P O	THIS YEAR TOTAL ISSUED	DEMAND	TOTAL ON HAND VALUE
	BLDG	SEC														
73-0056	DDC	01 056	EA	CIRCUIT, INT, PKG, V300RES			2,2500	3	1	2			1			4,500
73-0057	DDC	01 057	EA	CIRCUIT, INT, PKG, V3002RR			5,0000	2	1	3			1			15,000
73-0058	DDC	01 058	EA	CIRCUIT, INT, PKG, C3004NS			3,0000	3	1	3			1			9,000
73-0059	DDC	01 059	EA	CIRCUIT, INT, PKG, C3004N			1,0000	3	1	5			1			5,000
73-0060	DDC	01 060	EA	CIRCUIT, INT, PKG, C3004NW			1,2500	10	1	9			1	1		11,250
73-0061	DDC	01 061	EA	CIRCUIT, INT, PKG, C3004PJ			2,5000	2	1	2			1			5,000
73-0062	DDC	01 062	EA	CIRCUIT, INT, PKG, C3007MQ			2,0000	2	1	2			1			4,000
73-0063	DDC	01 063	EA	CIRCUIT, INT, PKG, V300RFA			2,7500	10	1	8			1			22,000
73-0064	DDC	01 064	EA	CIRCUIT, INT, PKG, V3008ER			2,7500	4	1	5			1			5,500
73-0065	DDC	01 065	EA	CIRCUIT, INT, PKG, V3008EC			3,7500	4	1	2			1			15,000
73-0066	DDC	01 066	EA	CIRCUIT, INT, PKG, V3008EF			2,7500	2	1	2			1			5,500
73-0067	DDC	01 067	EA	CIRCUIT, INT, PKG, V3008EF			2,2500	3	1	3			1			6,750
73-0068	DDC	01 068	EA	CIRCUIT, INT, PKG, V3008EK			2,2500	3	1	3			1			6,750
73-0069	DDC	01 069	EA	CIRCUIT, INT, PKG, V3008EI			3,0000	5	2	5			1			15,000
73-0070	DDC	01 070	EA	CIRCUIT, INT, PKG, V3008EW			4,0000	2	1	2			1			8,000
73-0071	DDC	01 071	EA	CIRCUIT, INT, PKG, V3008F7			5,5000	10	5	6			1			33,000
73-0072	DDC	01 072	EA	CIRCUIT, INT, PKG, V3008F5			11,5000	2	1	2			1			23,000
73-0073	DDC	01 073	EA	SUBMODULE, PLUG-IN, (G, D) C3012M			10,0000	1	1	1			1			10,000
73-0074	DDC	01 074	EA	SUBMODULE, PLUG-IN, (PD) C3012VJ			24,5000	1	1	1			1			24,500
73-0075	DDC	01 075	EA	SUBMODULE, PLUG-IN, (GD) C3013GS			13,5000	1	1	1			1			13,500
73-0076	DDC	01 076	EA	SUBMODULE, PLUG-IN, (RT) C30047I			4,7500	1	1	1			1			4,750
73-0077	DDC	01 077	EA	SUBMODULE, PLUG-IN, (GD) C3004TY			5,0000	5	2	5			1			25,000
73-0078	DDC	01 078	EA	SUBMODULE, PLUG-IN, (LD) C3004WA			8,5000	5	2	5			1			42,500
73-0079	DDC	01 079	EA	SUBMODULE, PLUG-IN, (PD) C3004WT			5,5000	5	2	5			1			27,500
73-0080	DDC	01 080	EA	SUBMODULE, PLUG-IN, (RT) C3004YY			5,0000	1	1	1			1			5,000
73-0081	DDC	01 081	EA	SUBMODULE, PLUG-IN, (RT) C3004ZE			4,5000	1	1	1			1			4,500
73-0082	DDC	01 082	EA	SUBMODULE, PLUG-IN, (RT) C3004ZF			5,0000	2	1	2			1			10,000
73-0083	DDC	01 083	EA	SUBMODULE, PLUG-IN, (RT) C30047K			6,0000	2	1	2			1			12,000
73-0084	DDC	01 084	EA	SUBMODULE, PLUG-IN, (RT) C3006MH			6,0000	2	1	2			1			12,000
73-0085	DDC	01 085	EA	SUBMODULE, PLUG-IN, (TC) C3006KK			7,5000	1	1	1			1			7,500
73-0086	DDC	01 086	EA	SUBMODULE, PLUG-IN, (TC) C3006KR			4,0000	1	1	1			1			4,000
73-0087	DDC	01 087	EA	SUBMODULE, PLUG-IN, (TC) C3006KR			9,0000	1	1	1			1			9,000
73-0088	DDC	01 088	EA	LAMP CARTRIDGE, AMFR, C3001WB			2,0000	10	5	10			1			20,000
73-0089	DDC	01 089	EA	LAMP CONSOLE, IND, TYPE OI-1			3,7500	10	5	10			1			37,500
73-0090	DDC	01 090	EA	TRANSISTOR, IND, DRIVER, 2N3009			1,2500	4	2	4			1			5,000
73-0091	DDC	01 091	EA	SWITCH, ROCKER, CONSOLE, V3008TF			1,2500	4	2	4			1			5,000
73-0092	DDC	01 092	EA	SWITCH, ROCKER, CONSOLE, V3008TK			1,5000	4	2	4			1			6,000
73-0093	DDC	01 093	EA	HANDLE, ROCKER, CONSOLE, GRAY			0,6500	2	1	2			1			1,300
73-0094	DDC	01 094	EA	HANDLE, ROCKER, CONSOLE, ORANGE			0,6500	2	1	2			1			1,300
73-0095	DDC	01 100	EA	FILTER, AIR, C3241RR, CENTRAL			13,0000	4	2	4			1			52,000
73-0096	DDC	01 095	EA	FUSE, 3AG, 2 AMP, C3510HH, CENTRA			0,1000	5	2	5			1			5,000
73-0097	DDC	01 096	EA	FUSE, 3AG, 6 AMP, C3510HH, CTRL			0,1000	5	2	5			1			5,000
73-0098	DDC	01 097	EA	FUSE, 3AG, 5AMP, C3510KH, CENTRAL			0,2000	5	2	5			1			10,000
73-0099	DDC	01 101	EA	FAN, ROTRON, GOLD SFAL MUFFIN			5,2000	2	1	2			2			10,400
73-0100	DDC	01 098	EA	LAMP, IND, PWR, DIST, PANFIL 103FZ			0,6500	5	2	5			1			3,250
73-0101	DDC	02 102	EA	SWITCH, POWER LOCK, C3966TD			33,0000	1	1	1			1			33,000
73-0102	DDC	02 103	EA	SWITCH, SPDT TOGGLE, C3510TY			5,2500	2	1	2			1			10,500
73-0103	DDC	02 104	EA	SWITCH, DPDT TOGGLE, C3510T7			7,7500	2	1	2			1			15,500
73-0104	DDC	02 105	EA	TERMINAL, FASTON, CLIP, FEPAIF			0,0700	10	5	10			1			7,000
73-0105	DDC	02 106	EA	TERMINAL, FASTON, SINGL F, SPADE			0,0500	10	5	10			1			5,000
73-0106	DDC	02 107	EA	TERMINAL, FASTON, DRL, SPADE			0,0500	10	5	10			1			5,000
73-0107	DDC	02 108	EA	THYECTOR, GE, #6RS205P4R4			2,2000	1	1	1			1			2,200
73-0108	DDC	02 109	EA	LAMP, CARTRIDGE, PLUG, C3001WE			2,0000	10	5	10			1			20,000
73-0109	DDC	02 110	EA	PAPER, TADP, FANFOI D, C3201WH			5,0000	1	1	1			1			5,000
73-0110	DDC	02 110	EA	KIT, CLEANING, C3966WB, CENTRAL			15,0000	1	1	1			1			15,000

COMMODITY TOTAL

VALUE OF ITEMS TM

VALUE THIS MONTH

VALUE LAST MONTH

STOCK NUMBER	LOCATION		UI	ITEM DESCRIPTION	E T	UNIT VALUE	MAX QTY.	MIN. QTY.	ON HAND	REP.	ON ORDER	THIS YEAR TOTAL		TOTAL ON HAND VALUE
	BLDG	SEC										ISSUED	DEMAND	
73-0111	DDC	02	111	FA LAMP, G.E. 163R, D3005CR, CENTRAL		2.5000	5		5			1		12.50
73-0112	DDC	02	112	FA SWITCH, MINIATURE, C3511F4		7.0000	1		1			1		7.00
73-0113	DDC	02	113	FA SWITCH, CUTLER-HAMMER, 7574K2		4.8000	1		1			1		4.80
73-0114	DDC	02	114	FA SOCKET, LAMP, ILECRAFT, #12-230N		0.5000	1		1			1		.50
73-0115	DDC	02	115	FA LENS (DIGITRONICS) C5AA6979-1		4.0000	1		1			1		4.00
73-0116	DDC	02	116	FA REFRAK, CIR., (DIGITRONICS)		9.5000	1		1			1		9.50
73-0117	DDC	02	117	FA RESISTOR, VARIABLE, F.15 OHM, 75W		6.5000	1		1			1		6.50
73-0118	DDC	02	118	FA RESISTOR, VARIABLE, F.50 OHM, 100W		8.7500	1		1			1		8.75
73-0119	DDC	02	119	FA RESISTOR, VARIABLE, F.100K, 172W		19.8000	1		1			1		19.80
73-0120	DDC	02	120	FA BEARING, FLGR, D3005CG, CENTRAL		30.0000	2		2			1		60.00
73-0121	DDC	02	121	FA ROLLER, TAPE (DIGITRONICS) AA702		3.5000	1		1			1		3.50
73-0122	DDC	02	122	FA ROLLER, SHAFT, (DIGITRONICS)		1.7500	1		1			1		1.75
73-0123	DDC	02	123	EA SFTSCREW, #3x.48 X 1/8" C3287XY		0.6000	5		5			1		3.00
73-0124	DDC	02	124	EA SOLENOID, LEFELY, A37240-002		50.0000	1		1			1		50.00
73-0125	DDC	02	125	EA SPRING, FLAT, PINCH ROLLER,		3.2500	1		1			1		3.25
73-0126	DDC	02	126	FA SPRING, COMPRESSION, C39665H		2.2500	1		1			1		2.25
73-0127	DDC	02	127	FA PAD, FFLI (DIGITRONICS) D3005CS		0.5000	1		1			1		.50
73-0128	DDC	02	128	EA CAPSTAN, ASSY, D3005CF, CENTRAL		62.0000	1		1			1		62.00
73-0129	DDC	02	129	EA SFTSCREW, #6-32X1/8", C3287XX		0.6000	5		5			1		3.00
73-0130	DDC	02	130	FA LOCK HEAD (DIGITRONICS RC7057)		75.0000	1		1			1		75.00
73-0131	DDC	02	131	FA SUPPLY, POWER, PCB, C3202KF		63.0000	1		1			1		63.00
73-0132	DDC	02	132	FA TAPE GUIDE, HARP		3.2500	1		1			1		3.25
73-0133	DDC	02	133	FA GUIDE ASSY, ADJUSTABLE		69.0000	1		1			1		69.00
73-0134	DDC	02	134	FA SPRING, EXTENSION		1.2500	1		1			1		1.25
73-0135	DDC	02	135	EA BRAKE ASSY, (DIGITRONICS) B		125.0000	1		1			1		125.00
73-0136	DDC	02	136	FA DIODE, IN4141C3005CD, CENTRAL		4.2500	2		2			1		8.50
73-0137	DDC	02	137	EA ASSY, PCB, (DIGITRONICS) DC70431		390.0000	1		1			1		390.00
73-0138	DDC	02	138	FA HEAD, PHOTO, PCR, (DIGITRONICS)		155.0000	1		1			1		155.00
73-0139	DDC	02	139	FA MOTOR/CAPACITOR, ASSY, C3358AD		220.0000	1		1			1		220.00
73-0140	DDC	02	140	FA KIT, LUBRICATOR, C3202LA, C.TPL.		13.5000	1		1			1		13.50
73-0141	DDC	02	141	EA BELT, TIMING/TIMER DRIVE		4.2500	2		2			1		8.50
73-0142	DDC	02	142	EA FUSE, 1A, 50, C3510KS, CENTRAL		0.4000	5		5			1		2.00
73-0143	DDC	02	143	EA FUSE, 2A, 50, C3510KX, CENTRAL		0.4000	5		5			1		2.00
73-0144	DDC	02	144	FA SWITCH, TAPE FEED, C3202LC		16.5000	1		1			1		16.50
73-0145	DDC	02	145	FA DRIVER, PUNCH, PCR, C3202MA		145.0000	1		1			1		145.00
73-0146	DDC	02	146	FA CONTROL, PERFORATOR, PCR, C3202M		160.0000	1		1			1		160.00
73-0147	DDC	02	147	FA CLOCK, PERFORATOR, PCR, C3202MC		275.0000	1		1			1		275.00
73-0148	DDC	02	148	FA BOARD ASSY, RD-2, C3202ME		37.0000	1		1			1		37.00
73-0149	DDC	02	149	FA BOARD ASSY, RD-2, C3202MF		37.0000	1		1			1		37.00
73-0150	DDC	02	150	EA TRANSISTOR, 2N3055, C3480GR		4.0000	1		1			1		4.00
73-0151	DDC	02	151	EA RECTIFIER, MDA-952-2, C3202MG		9.0000	2		2			1		18.00
73-0152	DDC	02	152	FA RELAY, 3 PNT, 12V, C3202MH		23.5000	1		1			1		23.50
73-0153	DDC	02	153	EA PULLEY, MOTOR, START, C3202MI		5.0000	1		1			1		5.00
73-0154	DDC	02	154	EA PULLEY, 12 TOOTH, C3202MJ		6.5000	1		1			1		6.50
73-0155	DDC	02	155	EA PULLEY, 16 TOOTH, C3202MK		7.0000	1		1			1		7.00
73-0156	DDC	02	156	EA PULLEY, 60 HZ, DRIVE, C3202ML		6.5000	1		1			1		6.50
73-0157	DDC	02	157	EA CAPSTAN, W/PINS, C3202ML		47.5000	1		1			1		47.50
73-0158	DDC	02	158	EA RESISTOR, 82 OHM, 2W, C3470FG		0.4000	1		1			1		.40
73-0159	DDC	02	159	EA CHUTE, CHAD, C3202LL, CTRL		6.0000	1		1			1		6.00
73-0160	DDC	02	160	FA BLOWER, CPU, RACKS, C3261BX		205.0000	1		1			1		205.00
73-0161	DDC	02	161	EA BOARD, PRINTED CIR, G793		19.5000	1		1			1		19.50
73-0162	DDC	02	162	FA CONN, DEC, PCR, M900, V300RRS		65.0000	1		1			1		65.00
73-0163	DDC	02	163	FA CONN, DEC, PCR, W011, C3201LL		26.0000	1		1			1		26.00
73-0164	DDC	02	164	FA CONN, DEC, PCR, W021, C3201HL		7.0000	1		1			1		7.00
73-0165	DDC	02	165	FA CONN, DEC, PCR, W025, C3201		10.0000	1		1			1		10.00

STOCK NUMBER	LOCATION		UL	ITEM DESCRIPTION	E T	UNIT VALUE	MAX. QTY.	MIN. QTY.	ON HAND	REP.	ON ORDER	PO	THIS YEAR TOTAL		TOTAL ON HAND VALUE
	BLDG	SEC											ISSUED	DEMAND	
73-0166	DDC	02 164	EA	CONNECTOR, DEC TYPE, C3004LZ		8.0000		1					1		8.00
73-0167	DDC	02 165	EA	CONN, POWER, DFC, PCB, G752		33.0000		1					1		33.00
73-0168	DDC	02 166	EA	CONN, DFC, PCB, W033, V30085F		8.5000		1					1		8.50
73-0169	DDC	02 167	EA	FORMAR, X-117 V/6, 3 VAC C3009T		4.0000		1					1		4.00
73-0170	DDC	02 168	EA	RELAY ASSY, CONTRACTOR, C3009T		31.0000		1					1		31.00
73-0171	DDC	02 169	EA	TERMINATOR, POWER, CARL E-12-03		10.0000		1					1		10.00
73-0172	DDC	02 170	EA	CAPACITOR, 16000 MFD, 20VDC		51.0000		1					1		51.00
73-0173	DDC	02 171	EA	CAPACITOR, 5700MFD, V3007RF		35.0000		1					1		35.00
73-0174	DDC	01 002	EA	POWER AUX, 50/60HZ, (0026023)		190.0000		1					1		190.00
73-0175	DDC	02 172	EA	TOGGLE SWITCH, POWER DIST.		2.7000		1					1		2.70
73-0176	DDC	02 173	EA	DIODE, 1N645, C3490CC, CENTRAL		0.9000		5	2				4		3.60
73-0177	DDC	02 174	EA	LAMP CARTRIDGE, RFD, C3001WL		2.0000		10	5	10			1		20.00
73-0178	DDC	02 175	EA	SWITCH, MINATURE, PUSHBUTTON		9.0000		2	1	2			1		18.00
73-0179	DDC	02 176	EA	FASTENER, PUSHBUTTON, SWING FR.		1.6500		1	1	1			1		1.65
73-0180	DDC	02 177	EA	BRACKET, PUSHBUTTON, FASTENER		1.6500		1	1	1			1		1.65
73-0181	DDC	02 178	EA	RUMPER, RUBBER, AR9110, CENTRAL		0.1100		5	2	5			1		5.55
73-0182	DDC	02 179	EA	HOUSING, MODULE, IND, (2 LAMP)		5.0000		1	1	1			1		5.00
73-0183	DDC	02 180	EA	SWITCH, MOMENTARY, SPDT, C3510RH		7.0000		1	1	1			1		7.00
73-0184	DDC	02 181	EA	LAMP, INDICATOR, 6V, C3398CR		0.5500		5	2	5			1		2.75
73-0185	DDC	02 182	EA	SWITCH, ALT, SPDT, C3511FC, CTR.		16.5000		1	1	1			1		16.50
73-0186	DDC	02 183	EA	HOUSING, IND, (4 LAMP) C3398XE		8.0000		1	1	1			1		8.00
73-0187	DDC	02 184	EA	CONN, 14 PIN, ADAPTER PLUG		2.0000		5	2	5			1		10.00
73-0188	DDC	02 185	EA	CONN, 50 PIN, WINCHESTER C3211H		7.5000		1	1	1			1		7.50
73-0189	DDC	02 186	EA	PIN, WIRE WRAP, C3004M7, CTRL		0.3500		100	50	100			1		35.00
73-0190	DDC	02 187	EA	DIODE, 1N3653 (CORESTACK)		3.2500		10	5	10			1		32.50
73-0191	DDC	02 188	EA	DIODE, RECT, DM2, V3008XE, CTR		16.0000		2	1	2			1		32.00
73-0192	DDC	02 190	EA	DIODE, RECT, DM1, V3008XF		16.0000		2	1	2			1		32.00
73-0193	DDC	02 191	EA	LAMP, IND, SYLVANIA 48F5R		1.0000		5	2	5			1		5.00
73-0194	DDC	02 192	EA	SWITCH, THERMAL, C3510WA		7.6333		1	3	3			1		22.89
73-0195	DDC	02 193	EA	SUPPLY POWER, TYPE H716		365.0000		1	1	1			1		365.00
73-0196	DDC	02 194	EA	SUPPLY POWER, LOGIC, (+5V)		275.0000		1	1	1			1		275.00
73-0197	DDC	02 195	EA	SUPPLY POWER, LOGIC, (-5V)		140.0000		1	1	1			1		140.00
73-0198	DDC	02 196	EA	STACK CORF, #12 FIT, 30-0525A-D		2400.0000		1	1	1			1		2400.00
73-0199	DDC	02 197	EA	GREASE, SILICONE (TURF) 4R130		4.0500		1	1	1			1		4.05
73-0200	DDC	02 198	EA	OIL, LUBRICATING, (OT) C3161P4		3.7500		1	1	1			1		3.75
73-0201	DDC	03 203	EA	GREASE, (1 R JAR) C3161PX		1.2500		1	1	1			1		1.25
73-0202	DDC	03 204	EA	LAMP, (GF82) C3398RH, DDC		0.3500		5	2	5			1		1.75
73-0203	DDC	03 205	EA	LAMP, (GE55) C3003BW, DDC		0.1000		5	2	5			1		0.50
73-0204	DDC	03 206	EA	FUSE, 2.5A, 5/8, C3510KY, X		0.4000		5	2	5			1		2.00
73-0205	DDC	03 207	EA	FUSE, 3/8A, 5/8, C3510KN DDC		0.2000		5	2	5			1		1.00
73-0206	DDC	03 208	EA	FUSE, 6 1/4A, C3510LC, DDC		0.2500		5	2	5			1		1.25
73-0207	DDC	03 209	EA	PIPPON, SPOOL, (TTC #7835)		0.9000		6	3	6			1		5.40
73-0208	DDC	03 210	EA	PAPER, TELETYPE, (RDX)		21.0000		2	1	2			1		42.00
73-0209	DDC	03 207	EA	PAPER TAPE, FANFOUR (CASEF)		4.0556		40	20	33			1		133.83
73-0210	DDC	03 203	EA	FUSE, 4A, 5/8, C3510LA, DDC		0.4000		5	2	5			1		2.00
73-0211	DDC	03 211	EA	COVER, GI ASS, (TTC#192073)		3.5000		1	1	1			1		3.50
73-0212	DDC	03 212	EA	CONTACT BOX ASSY, (TTC197019)		23.5000		1	1	1			1		23.50
73-0213	DDC	03 213	EA	COUPLING (TTC 193565) C3003RS		1.2500		1	1	1			1		1.25
73-0214	DDC	03 214	EA	GEAR SFT, 40 HZ, (TTC 161295)		4.3333		2	1	3			1		12.99
73-0215	DDC	03 215	EA	RELAY, PCB, ASSY, (DEC #4915)		54.0000		1	1	1			1		54.00
73-0216	DDC	03 216	EA	REFLECTOR, (G.F. ARS205P4PX)		2.2000		1	1	1			1		2.20
73-0217	DDC	03 217	EA	SUBMODULE, PLUG-IN (TTC C300A5)		7.2500		1	1	1			1		7.25
73-0218	DDC	03 218	EA	SUBMODULE, PLUG-IN (TTC C3011CP)		8.0000		1	1	1			1		8.00
73-0219	DDC	03 219	EA	SUBMODULE, PLUG-IN, (RPP) C3004ZF		7.7500		1	1	1			1		7.75
73-0220	DDC	03 221	EA	SUBMODULE, PLUG-IN, (RPP) C3004ZF		7.7500		1	1	1			1		7.75

STOCK NUMBER	LOCATION	BLDG	SEC	BIN	NO	UL	ITEM DESCRIPTION	E	T	UNIT VALUE	MAX. QTY.	MIN. QTY.	ON HAND	REP.	ON ORDER	P.O.	THIS YEAR TOTAL ISSUED	DEMAND	TOTAL ON HAND VALUE
73-0221	DDC	03	222			EA	SUBMODULE, PLUG-IN, (LD)C3004WA			11.5000	1	1	1						11.50
73-0222	DDC	03	223			EA	SUBMODULE, PLUG-IN (GD)C3004TY			5.5000	5	2	5						27.50
73-0223	DDC	03	224			EA	SUBMODULE, PLUG-IN (FL)TER			14.0000	1	1	1						14.00
73-0224	DDC	03	225			EA	SUBMODULE, PLUG-IN (RT)C3012MK			9.5000	1	1	1						9.50
73-0225	DDC	03	226			EA	SUBMODULE, PLUG-IN (TC)C3006LC			9.0000	1	1	1						9.00
73-0226	DDC	03	227			EA	SUBMODULE, PLUG-IN (TC)C3006KN			7.5000	1	1	1						7.50
73-0227	DDC	03	228			EA	SUBMODULE, PLUG-IN (TC)C3006LR			7.0000	1	1	1						7.00
73-0228	DDC	03	229			EA	SUBMODULE, PLUG-IN (TC)C3006LR			9.0000	1	1	1						9.00
73-0229	DDC	03	230			EA	SUBMODULE, PLUG-IN (TC)C3006KX			9.0000	1	1	1						9.00
73-0230	DDC	03	231			EA	SUBMODULE, PLUG-IN (TC)C30066N			9.0000	2	1	2						18.00
73-0231	DDC	03	232			EA	SUBMODULE, PLUG-IN (TC)C3006LP			7.0000	1	1	1						7.00
73-0232	DDC	03	233			EA	SUBMODULE, PLUG-IN (LUR)C3004TM			69.0000	2	1	2						138.00
73-0233	DDC	03	234			EA	SUBMODULE, PLUG-IN (NR)C3004TL			23.5000	1	1	1						23.50
73-0234	DDC	03	235			EA	SUBMODULE, PLUG-IN (RD)C3004WT			6.0000	5	2	5						30.00
73-0235	DDC	03	236			EA	SUBMODULE, PLUG-IN (RT)C3012MH			10.0000	1	1	1						10.00
73-0236	DDC	03	237			EA	SUBMODULE, PLUG-IN (DR)C3004TW			7.5000	1	1	1						7.50
73-0237	DDC	03	238			EA	SUBMODULE, PLUG-IN, (TC)C3006KM			7.5000	1	1	1						7.50
73-0238	DDC	03	239			EA	SUBMODULE, PLUG-IN, (CON)C3004			2.0000	2	1	2						4.00
73-0239	DDC	03	240			EA	SUBMODULE, PLUG-IN, (C)C3011Y			19.5000	3	1	3						58.50
73-0240	DDC	03	241			EA	SUBMODULE, PLUG-IN (SSR)C3004TT			15.0000	2	1	2						30.00
73-0241	DDC	03	242			EA	SUBMODULE, PLUG-IN (V)C3012VJ			24.5000	1	1	1						24.50
73-0242	DDC	03	243			EA	SUBMODULE, PLUG-IN (GN)C3013GV			10.0000	1	1	1						10.00
73-0243	DDC	03	244			EA	SUBMODULE, PLUG-IN (CT)C3008			7.0000	1	1	1						7.00
73-0244	DDC	03	245			EA	SUBMODULE, PLUG-IN, (NR)C3012NM			12.0000	1	1	1						12.00
73-0245	DDC	03	246			EA	SUBMODULE, PLUG-IN (NL)C3004WK			13.0000	10	5	10						130.00
73-0246	DDC	03	247			EA	SUBMODULE, PLUG-IN (TC)C3006KF			7.2500	2	1	2						14.50
73-0247	DDC	03	248			EA	SUBMODULE, PLUG-IN (TC)C3004LA			9.0000	1	1	1						9.00
73-0248	DDC	03	249			EA	SUBMODULE, PLUG-IN (DH)C3004WF			13.0000	10	5	10						130.00
73-0249	DDC	03	250			EA	SUBMODULE, PLUG-IN (DR)C3012N			13.7500	1	1	1						13.75
73-0250	DDC	03	251			EA	SUBMODULE, PLUG-IN (PT)C3012PA			13.7500	1	1	1						13.75
73-0251	DDC	03	252			EA	SUBMODULE, PLUG-IN (GN)C3012MG			10.0000	1	1	1						10.00
73-0252	DDC	03	253			EA	SUBMODULE, PLUG-IN (RTG)C3004YY			6.0000	1	1	1						6.00
73-0253	DDC	03	254			EA	SUBMODULE, PLUG-IN (RTP)C3004ZK			7.7500	1	1	1						7.75
73-0254	DDC	03	255			EA	SUBMODULE, PLUG-IN (RTP)C3006MC			5.0000	2	1	2						10.00
73-0255	DDC	03	256			EA	SUBMODULE, PLUG-IN (RP)C3012N2			8.7500	1	1	1						8.75
73-0256	DDC	03	257			EA	SUBMODULE, PLUG-IN (TC)C3006KX			7.5000	1	1	1						7.50
73-0257	DDC	03	258			EA	SUBMODULE, PLUG-IN (TC)C3005LF			9.0000	1	1	1						9.00
73-0258	DDC	03	259			EA	SUBMODULE, PLUG-IN (TC)C3006KS			9.0000	1	1	1						9.00
73-0259	DDC	03	260			EA	SUBMODULE, PLUG-IN (DS)C3007LA			8.5000	10	5	10						85.00
73-0260	DDC	03	261			EA	SUBMODULE, PLUG-IN (TC)C3006LF			9.0000	1	1	1						9.00
73-0261	DDC	03	262			EA	SUBMODULE, PLUG-IN, (DM)C30084L			15.5000	4	2	3						46.50
73-0262	DDC	03	263			EA	SUBMODULE, PLUG-IN, (TC)C3006KZ			9.0000	2	1	2						18.00
73-0263	DDC	03	264			EA	SUBMODULE, PLUG-IN (TC)C3006KF			7.5000	1	1	1						7.50
73-0264	DDC	03	265			EA	SUBMODULE, PLUG-IN (TC)C3004LY			12.0000	1	1	1						12.00
73-0265	DDC	03	266			EA	SUBMODULE, PLUG-IN (TC)C3006KP			11.5000	1	1	1						11.50
73-0266	DDC	03	267			EA	SUBMODULE, PLUG-IN (RT)C3004YR			4.5000	3	1	3						13.50
73-0267	DDC	03	268			EA	SUBMODULE, PLUG-IN (RT)C3004YT			4.7500	2	1	2						9.50
73-0268	DDC	03	269			EA	SUBMODULE, PLUG-IN (TC)C3006KY			8.2500	1	1	1						8.25
73-0269	DDC	03	270			EA	SUBMODULE, PLUG-IN (RT)C3006MM			13.0000	1	1	1						13.00
73-0270	DDC	03	271			EA	SUBMODULE, PLUG-IN (RT)C3012MF			9.0000	1	1	1						9.00
73-0271	DDC	03	272			EA	SUBMODULE, PLUG-IN (DVI)C3012MJ			12.0000	1	1	1						12.00
73-0272	DDC	03	273			EA	CIRCUIT, INT. PKG. V3008FA			3.5500	1	1	1						3.55
73-0273	DDC	03	274			EA	CIRCUIT, INT. PKG. V3008ER			3.5500	1	1	1						3.55
73-0274	DDC	03	275			EA	CIRCUIT, INT. PKG. V3008EC			3.7500	6	3	6						22.50
73-0275	DDC	03	276			EA	CIRCUIT, INT. PKG. C3004NW			2.2500	1	1	1						2.25

STOCK NUMBER	LOCATION	BI	SEC	BN	NO	UI	ITEM DESCRIPTION	E I T	UNIT VALUE	MAX QTY.	MIN QTY.	ON HAND	REP.	ON ORDER	P.O.	THIS YEAR TOTAL ISSUED	DEMAND	TOTAL ON HAND VALUE
73-0276	DDC 03	277				FA	CIRCUIT, INT, PKG. C3113AG		4.2500	2	1	2			1			8.50
73-0277	DDC 03	278				FA	CIRCUIT, INT, PKG. V3008EF		2.7500	2	1	2			1			5.50
73-0278	DDC 03	279				FA	CIRCUIT, INT, PKG. V3008EF		2.7500	2	1	1			1			2.75
73-0279	DDC 03	280				FA	CIRCUIT, INT, PKG. V3008EF		2.7500	2	1	4			1			10.75
73-0280	DDC 03	281				FA	CIRCUIT, INT, PKG. V3008EF		3.0000	5	2	5			1			15.00
73-0281	DDC 03	282				FA	CIRCUIT, INT, PKG. C4008FI		13.0000	2	1	2			1			26.00
73-0282	DDC 03	283				FA	CIRCUIT, INT, PKG. V3008EF		7.0000	1	1	1			1			7.00
73-0283	DDC 03	284				FA	CIRCUIT, INT, PKG. C3008B7		2.5000	2	1	2			1			5.00
73-0284	DDC 03	285				FA	CIRCUIT, INT, PKG. C3004P		2.5000	5	2	5			1			12.50
73-0285	DDC 03	286				FA	CIRCUIT, INT, PKG. C3004R		3.0000	2	1	2			1			6.00
73-0286	DDC 03	287				EA	CIRCUIT, INT, PKG. C3002RR		14.5000	1	1	1			1			14.50
73-0287	DDC 03	288				FA	BOARD, PC, TYPE "056" C3100CN		136.0000	2	1	2			1			272.00
73-0288	DDC 03	289				FA	BOARD, PC, TYPE "057" C3100CP		99.0000	6	3	6			1			594.00
73-0289	DDC 03	290				EA	BOARD, PC, TYPE "067" C31005R		87.0000	2	1	2			1			174.00
73-0290	DDC 03	291				FA	BOARD, PC, "077", C3100DA		145.0000	2	1	2			1			290.00
73-0291	DDC 03	292				FA	BOARD, PC, TYPE "122" C3100FT		145.0000	2	1	2			1			290.00
73-0292	DDC 03	293				FA	BOARD, PC, TYPE "123" C3100FW		119.0000	5	2	5			1			595.00
73-0293	DDC 03	294				FA	BOARD, PC, TYPE "133" C3100GG		165.0000	1	1	1			1			165.00
73-0294	DDC 03	295				FA	BOARD, PC, (S.O. RELAY) 30003		32.0000	5	2	5			1			160.00
73-0295	DDC 03	296				FA	OSCILLATOR, CRYSTAL, 125KC (VCM)		225.0000	1	1	1			1			225.00
73-0296	DDC 03	297				FA	SIGNAL CONDITIONER, FILTER		23.0000	5	2	5			1			115.00
73-0297	DDC 03	298				FA	SWITCH, ROCKER, SPST, C40027X		1.2500	1	1	1			1			1.25
73-0298	DDC 03	299				FA	SWITCH, ROCKER, DPST, C30027Y		1.2500	1	1	1			1			1.25
73-0299	DDC 03	300				FA	SWITCH, TOGGLE, SPDT, C3510TY		6.7500	1	1	1			1			6.75
73-0300	DDC 03	301				FA	SWITCH, TOGGLE, DPDT, C4510T7		10.0000	1	1	1			1			10.00
73-0301	DDC 03	302				FA	SWITCH, PUSHBUTTON, C3510AP, DDC		11.5000	1	1	1			1			11.50
73-0302	DDC 03	303				FA	SWITCH, ROCKER, C3004MA, DDC		3.2500	1	1	1			1			3.25
73-0303	DDC 03	304				EA	FUSE, 2 AMP, C3510HH, DDC		0.1200	1	1	1			1			.12
73-0304	DDC 03	305				EA	FUSE, 6 AMP, C3510HN, DDC		0.1000	1	1	1			1			.10
73-0305	DDC 03	306				EA	FUSE, 1 AMP, C3510KC, DDC		0.1000	5	2	5			1			.50
73-0306	DDC 04	312				FA	FUSE, 3 AMP, C3510KF, DDC		0.1000	5	2	5			1			.50
73-0307	DDC 04	313				FA	FUSE, 12 AMP, C3510LM, DDC		0.2500	5	2	5			1			1.25
73-0308	DDC 04	314				EA	PREAKER, CIRCUIT, 10A, C3004NF		31.0000	1	1	1			1			31.00
73-0309	DDC 04	315				EA	PREAKER, CIRCUIT, 20A, C3000MA		45.0000	1	1	1			1			45.00
73-0310	DDC 04	316				FA	LAMP, CARTRIDGE, 6V, AMPER, C3001		2.5000	1	1	1			1			2.50
73-0311	DDC 04	317				FA	LAMP, CARTRIDGE, 6V, RIUE, C3001		2.5000	1	1	1			1			2.50
73-0312	DDC 04	318				FA	LAMP, CARTRIDGE, 6V, REF, C3001XL		2.5000	1	1	1			1			2.50
73-0313	DDC 04	319				FA	LAMP, CART., 28V, RIUE, C3004CT		2.0000	5	2	5			1			10.00
73-0314	DDC 04	320				FA	LAMP, INDICATOR, IPWR ONI1103FZ		0.2000	1	1	1			1			.20
73-0315	DDC 04	321				FA	FIL TER, R-V, V3007RV, DDC		16.0000	1	1	1			1			16.00
73-0316	DDC 04	322				FA	RECEPTACH, FASTON TERMINAL		0.0900	1	1	1			1			.09
73-0317	DDC 04	323				FA	CLIP, FASTON, SINGLE SPARE		0.0400	1	1	1			1			.04
73-0318	DDC 04	324				FA	TAB, FASTON, V3007CL, DDC		0.0500	5	2	5			1			.25
73-0319	DDC 04	325				FA	HOUSING, STAR, FASTON, V3007CM		0.0500	5	2	5			1			.25
73-0320	DDC 04	326				FA	FIL TER, AIR, 10026016-51, DDC		16.7500	1	1	1			1			16.75
73-0321	DDC 04	327				EA	ALOXER, 50/60H7, STD, RACK		265.0000	1	1	1			1			265.00
73-0322	DDC 04	328				EA	DICPE, IN458, C30095L, DDC		0.7000	2	1	2			1			1.40
73-0323	DDC 04	329				FA	RELAY, 24VDC, C30104X, DDC		25.0000	1	1	1			1			25.00
73-0324	DDC 04	330				FA	RELAY, TIME DELAY, C3010Y, DDC		120.0000	1	1	1			1			120.00
73-0325	DDC 04	312				FA	SUPPLY POWER, 24VDC (SYS. SFC)		285.0000	1	1	1			1			285.00
73-0326	DDC 04	315				FA	CARD ASSY, A/D PRE AMP SWITCH		590.0000	1	1	1			1			590.00
73-0327	DDC 04	318				FA	AMPLIFIER, DIFFERENTIAL A/D		1590.0000	1	1	1			1			1,590.00
73-0328	DDC 04	331				FA	CONVERTER A/D, 12 BIT, C3002RK		1070.0000	1	1	1			1			1,070.00
73-0329	DDC 04	332				FA	SUPPLY POWER, CONVERTER, REFFER.		355.0000	1	1	1			1			355.00
73-0330	DDC 04	333				FA	AMPLIFIER, OPERATIONAL A/D		73.0000	1	1	1			1			73.00

COMMODITY TOTAL

VALUE LAST MONTH

VALUE OF 'E' ITEMS TM

VALUE THIS MONTH

PROGRAM-035135 STOCK STATUS REPORT FOR MONTH ENDING 05 29 75 PAGE 338

STOCK NUMBER	LOCATION		UI	ITEM DESCRIPTION		E T	UNIT VALUE	MAX QTY.	MIN QTY.	ON HAND	REP.	ON ORDER	P O	THIS YEAR TOTAL ISSUED	DEMAND	TOTAL ON HAND VALUE
	BLDG	SEC		BIN	NO											
73-0331	DDC	04 334	EA	POTENTIOMETER,TRIM-POT)C3004P		4.0000	1		1				1		4.00	
73-0332	DDC	04 376	FA	SUPPLY,POWER,A/D REFERENCE		590.0000			1				1		590.00	
73-0333	DDC	04 376	FA	SUPPLY,POWER,LOGIC,5V, 7A,		0.0000	1						1		.00	
73-0334	DDC	04 376	FA	SUPPLY,POWER,LOGIC,5V, 7A,		0.0000	1						1		.00	
73-0335	DDC	04 379	FA	SUPPLY,POWER,26V,2.8A,C3007LL		220.0000	1		1				1		220.00	
73-0336	DDC	04 335	FA	SUPPLY,POWER,6.5V,2.5A,C3007		130.0000	1		1				1		130.00	
73-0337	DDC	04 390	FA	SUPPLY,POWER,6KV,C3007LP		450.0000	1		1				1		450.00	
73-0338	DDC	04 381	FA	SUPPLY,POWER,6.5V, 18A,C3010		300.0000	1		1				1		300.00	
73-0339	DDC	04 382	EA	SUPPLY,POWER,D/AREFFERENCE		340.0000	1		1				1		340.00	
73-0340	DDC	04 383	FA	SUPPLY,POWER,0-18V,V3005A,DDC		225.0000	1		1				1		225.00	
73-0341	DDC	04 384	EA	SUPPLY,POWER,0-32V, V3005C		225.0000	1		1				1		225.00	
73-0342	DDC	04 336	EA	RELAY,T-RAR,V3000BK, DDC		250.0000	1		1				1		250.00	
73-0343	DDC	04 337	FA	FUSE,4A,C3511CT,DDC		0.9000	2		5				1		4.50	
73-0344	DDC	04 338	FA	DIODE,1N647,L010FF, DDC		1.4750	2		1				1		2.95	
73-0345	DDC	04 386	FA	MODULE,DOM,MOD1,C3007SP,DDC		2310.0000	1		1				1		2,310.00	
73-0346	DDC	04 340	FA	CARTRIDGE,ARIBRON, FED/PLK,		3.5000	6		3				1		21.00	
73-0347			FA	PAPER,FOLDED,11"SIZE,C3201YW		19.5000	2		1				2		.00	
73-0348			FA	PAPER,FOLDED,15"SIZE,C3201FM		43.0000	2		1				2		.00	
73-0349	DDC	04 341	FA	KIT,CLEANING,TYPE V/FAN,C3966N		15.0000	1		1				1		15.00	
73-0350	DDC	04 342	FA	DIODE,CFR 69JUNCTION BOX		0.6500	5		2				1		3.25	
73-0351	DDC	04 343	FA	LAMP,INDICATOR,(GF 387)C3398C		0.9500	25		12				1		23.75	
73-0352	DDC	04 344	FA	TUBE,NIXIE,ALPHANUMERIC C3009		58.0000	4		4				1		232.00	
73-0353	DDC	04 345	FA	LAMP,DIAL,C07507-3917-1473		2.5357	5		2				2		17.74	
73-0354	DDC	04 344	FA	FUSE,3AG,5A,C3510KH, DDC		0.2000	25		7				1		5.00	
73-0355	DDC	04 347	FA	DIODE,1N458,C3009SL,DDC		0.7000	20		10				1		12.60	
73-0356	DDC	04 348	FA	SWITCH,RUP,(MICRO 7AH5)C3009		7.5000	10		5				1		75.00	
73-0357	DDC	04 349	FA	KEY TOP,(MICRO 2R43)C3009SE		0.9500	2		1				1		1.90	
73-0358	DDC	04 350	EA	KEY TOP,DOUBLE(MICRO 2R27)		1.7500	1		1				1		7.00	
73-0359	DDC	04 351	FA	SWITCH,MODULE,(MICRO 2D2)C3510		0.0000	1		1				1		.00	
73-0360	DDC	04 352	FA	SWITCH,MODULE(MICRO 2D5)C3510		0.0000	1		1				1		.00	
73-0361	DDC	04 353	FA	SWITCH,MODULE(MICRO 2D100)		6.0000	5		2				1		24.00	
73-0362	DDC	04 354	FA	HOUSING,INDICATOR, 2 LAMP C339		5.0000	2		4				1		5.00	
73-0363	DDC	04 355	FA	HOUSING,INDICATOR,4 LAMP C339		8.0000	2		1				1		16.00	
73-0364	DDC	04 356	FA	CIRCUIT, INT. PKG. C3009SM		8.5000	5		2				1		42.50	
73-0365	DDC	04 357	FA	CIRCUIT, INT. PKG. C3009SM		11.5000	5		2				1		57.50	
73-0366	DDC	04 358	FA	CIRCUIT, INT. PKG. C3009SP		2.7500	5		2				1		13.75	
73-0367	DDC	04 359	FA	CIRCUIT, INT. PKG. C3009SR		2.5000	5		2				1		12.50	
73-0368	DDC	04 360	FA	CIRCUIT, INT. PKG. C3009SS		15.7500	5		2				1		63.00	
73-0369	DDC	04 361	EA	CIRCUIT, INT. PKG. N410R		13.0000	5		2				1		39.00	
73-0370	DDC	04 362	EA	RELAY,IRM,766073,C3009TC		6.5000	3		1				1		19.50	
73-0371	DDC	04 363	EA	RELAY,IRM,766073,C3009TC		16.5000	1		1				1		16.50	
73-0372	DDC	04 364	FA	RELAY,IBM, 766071, C3009TC,CO		13.0000	1		1				1		13.00	
73-0373	DDC	04 365	FA	TRANSISTOR, 2N3054, C3009SW		2.7500	5		2				1		13.75	
73-0374	DDC	04 366	FA	TRANSISTOR,2N4409, C3009SY		1.0000	5		2				1		5.00	
73-0375	DDC	04 367	FA	TRANSISTOR,2N4402,C3009Z,DDC		0.5500	5		2				1		2.75	
73-0376	DDC	04 368	FA	TRANSISTOR,2N2646,C300957,DDC		2.2500	5		2				2		11.25	
73-0377	DDC	04 369	FA	PINS,CONNECTOR,(WINCHESTER)		0.1000	50		25				1		5.00	
73-0378	DDC	04 370	FA	PINS,CONNECTOR(WINCHESTER)		0.1000	50		25				1		5.00	
73-0379	DDC	04 371	FA	SWITCH,KEYLOCK,C3009TA, DDC		9.0000	1		1				1		9.00	
73-0380	DDC	04 372	FA	FAN,MUFFIN,ARB112,DDC CONSOLE		37.5000	1		1				1		37.50	
73-0381	DDC	04 385	FA	SUPPLY,POWER,180V,C3011FA		300.0000	1		1				1		300.00	
73-0382	DDC	04 387	FA	SUPPLY,POWER, +5V,C3011C7,DDC		165.0000	1		1				1		165.00	
73-0383	DDC	04 388	FA	SUPPLY,POWER,-28V,C3011CY		280.0000	1		1				1		280.00	
73-0387			FA	RELAY,700-N400-A1 ALLEN-BRAD		19.2000	5		2				1		134.40	
73-0388			FA	RELAY,700-N400-A1 ALLEN-BRAD		15.3600	5		2				1		46.08	

COMMODITY TOTAL VALUE OF E ITEMS TM VALUE THIS MONTH

STOCK NUMBER	LOCATION		UL	ITEM DESCRIPTION	E T	UNIT VALUE			ON ORDER	THIS YEAR TOTAL		TOTAL ON HAND VALUE
	BLDG	SEC				MIN. QTY.	MAX. QTY.	ISSUED		DEMAND		
73-0389	765	21	154	EA RELAY.#700-NM600-A1-A-R		32,640.00	6	1	4	1	130.56	
73-0390	765	21	091	EA RELAY.#700DC-224,ALLEN-BRAD.		25,920.00	6	1	6	1	155.52	
73-0391	765	21	091	EA RELAY.#700-RX640-A1 ALLEN-BR		33,600.00	2	1	2	1	67.20	
73-0392				EA RELAY.#700-RX440-A1,ALLEN-BR		22,560.00	4	1	4	1	90.24	
73-0393	765	21	076	EA RELAY.#700-RX840-A1-A-R		39,360.00	1	1	3	1	39.36	
73-0394				EA RELAY.#849A-70024,ALLEN-BR		35,270.00	2	1	3	1	105.80	
73-0395	765	21	175	EA RELAY.#1610-T0210524-A-R		16,320.00	10	4	10	1	163.20	
73-0396	765	21	176	EA RELAY.#1610-T02205A1, A-R		24,960.00	8	2	8	1	199.68	
73-0397	765	21	007	EA RELAY.#K138-30010,POTTIER		23,000.00	6	1	6	1	138.00	
73-0398	765	21	008	EA RELAY.#C51 3H-30010AP ZP		27,233.33	6	2	2	1	81.69	
73-0399	765	21	008	EA RELAY.#550-100001 C-S11,PRB		20,600.00	3	1	3	1	61.80	
73-0400	765	21	008	EA RELAY.#55F43-24VDC, SIGMA		9,500.00	2	2	2	1	19.00	
73-0401	765	21	185	EA FUSE,FOXRORO.#N0124TS,DDC		0,650.00	15	5	15	1	9.75	
73-0402	765	21	174	EA RELAY,FOXRORO.#N01967N,DDC		18,500.00	6	2	6	1	111.00	
73-0403	765	21	179	EA METER,FOXRORO.#N0196CY,DDC		51,000.00	1	1	1	1	51.00	
73-0404	765	21	180	EA METER,FOXRORO.#N0221FF,DDC		67,500.00	1	1	1	1	67.50	
73-0405	765	21	185	EA DIODE,FOXRORO.#N01205F,DDC		0,900.00	3	1	3	1	2.70	
73-0406	765	21	185	EA DIODE,FOXRORO.#N0110PP,DDC		2,000.00	3	1	3	1	6.00	
73-0407	765	21	185	EA VARIATOR,FOXRORO.#N0136AR		9,750.00	3	1	3	1	29.25	
73-0408	765	21	185	EA TRANSISTOR,FOXRORO.#N0119KT		8,750.00	3	1	3	1	26.25	
73-0409	765	21	185	EA FUSE(11PV),FOXRORO.#N0121EE		0,800.00	15	5	15	1	12.00	
73-0410	765	21	186	EA DIODE,FOXRORO.#N0109E7, DDC		2,000.00	9	3	9	1	18.00	
73-0411	765	21	186	EA DIODE, FOXRORO.#N0138AL,DDC		19,000.00	9	3	9	1	171.00	
73-0412	765	21	186	EA DIODE,FOXRORO.#N0131RK, DDC		5,900.00	6	2	6	1	35.40	
73-0413	765	21	186	EA TRANSISTOR,FOXRORO.#N0141MC		0,550.00	3	1	3	1	1.65	
73-0414	765	21	186	EA TRANSISTOR,FOXRORO.#N0196PT		4,750.00	6	2	6	1	28.50	
73-0415	765	21	186	EA TRANSISTOR,FOXRORO.#N0128FT		17,500.00	3	1	3	1	52.50	
73-0416	765	21	187	EA TRANSISTOR,FOXRORO.#N0131RP		4,750.00	6	2	6	1	28.50	
73-0417	765	21	187	EA TRANSISTOR, FOXRORO.#N0230ET		14,250.00	3	1	3	1	42.75	
73-0418	765	21	187	EA DIODE,FOXRORO.#N0135CT,DDC		13,500.00	6	2	6	1	81.00	
73-0419	765	21	187	EA FUSE,FOXRORO.#N0121EE, DDC		0,800.00	10	3	10	1	8.00	
73-0420	765	21	187	EA DIODE,FOXRORO.#N0109FC, DDC		2,000.00	6	2	6	1	12.00	
73-0421	765	21	206	PR CAPACITOR,FOXRORO.#N0115WM		21,000.00	4	2	4	1	84.00	
73-0422	765	21	204	EA DIODE,DUAL,FOXRORO.#N0149KK		3,950.00	2	1	2	1	7.90	
73-0423	765	21	204	EA DIODE,FOXRORO.#N0149FM, DDC		3,350.00	6	2	6	1	20.10	
73-0424	765	21	204	EA DIODE,FOXRORO.#N0149FL, DDC		11,750.00	4	2	4	1	47.00	
73-0425	765	21	204	EA TRANSISTOR,FOXRORO.#N0119KT		8,750.00	2	1	2	1	17.50	
73-0426	765	21	204	EA DIODE,FOXRORO.#N0120X5,DDC		10,900.00	2	1	2	1	21.80	
73-0427	765	21	204	EA DIODE,FOXRORO.#N0131PL, DDC		5,100.00	2	1	2	1	10.20	
73-0428	765	21	205	EA DIODE,FOXRORO.#N0120WN,DDC		9,300.00	2	1	2	1	18.60	
73-0429	765	21	205	EA TRANSISTOR,FOXRORO.#N01221P		11,250.00	4	2	4	1	45.00	
73-0430	765	21	205	EA CAPACITOR,FOXRORO.#N01491C		6,200.00	2	1	2	1	12.40	
73-0431	765	21	205	EA DIODE,FOXRORO.#N0150BB, DDC		2,800.00	2	1	2	1	5.60	
73-0432	765	21	205	EA PEN ASSY,PLUE,FOXRORO.#N0147X		1,900.00	2	1	2	1	3.80	
73-0433	765	00	000	EA PEN POINTER ASSY,BLUE,#N0206MW		1,650.00	1	1	1	1	1.65	
73-0434	765	21	205	EA PEN ASSY,GREEN.#N0147XX,DDC		1,900.00	2	1	2	1	3.80	
73-0435	765	21	203	EA MOTOR,PEN(R,H)#N01245A, DDC		225,000.00	1	1	1	1	225.00	
73-0436	765	21	206	EA TUBE,FOXRORO.#N0206TN, DDC		1,250.00	1	1	1	1	1.25	
73-0437	765	21	206	EA LINK ADJ. 2 5/8-3 5/16" FXBR.		4,250.00	1	1	1	1	4.25	
73-0438	765	21	206	EA LINK ADJ.2 15/16-3 5/16"FXBR.		4,250.00	1	1	1	1	4.25	
73-0439	765	21	206	EA LINK ADJ.3 1/4-3 15/16" FXBR		4,250.00	1	1	1	1	4.25	
73-0440	765	21	206	EA LINK ADJ.3 1/2-4 3/16" FXBR.		4,250.00	1	1	1	1	4.25	
73-0441	765	21	188	EA LINK ADJ.3 3/4-4 7/16" FXBR.		4,250.00	1	1	1	1	4.25	
73-0442	765	21	188	EA LINK ADJ.4-4 11/16" FOXRORO		5,050.00	1	1	1	1	5.05	
73-0443	765	21	188	EA LINK ADJ.4 1/4"-4 15/16"		4,250.00	1	1	1	1	4.25	

VALUE THIS MONTH

VALUE OF 'E' ITEMS TM

VALUE LAST MONTH

ITEMS

COMMODITY TOTAL

VALUE THIS MONTH

STOCK NUMBER	LOCATION			UL	ITEM DESCRIPTION	E T	UNIT VALUE	MAX QTY	MIN QTY	ON HAND	REP.	ON ORDER	P.O	THIS YEAR TOTAL		TOTAL ON HAND VALUE
	BLDG	SEC	BN											ISSUED	DEMAND	
73-0444	765	21	188		FA TURE ASSY (R.H.) FOXBORO DDC		7.2500	1		1				1		7.25
73-0445	765	21	188		FA RING, 0.1732" X 3/32" FOXBORO		0.4500	4	1	4				1		1.80
73-0446	765	21	188		FA TURE, FOXBORO, #N0206MZ, DDC		0.4000	1		1				1		0.40
73-0447	765	21	189		FA TURE ASSY (L.H) SINGL CAPSUL		7.2500	1		1				1		7.25
73-0448	765	21	189		FA TURE ASSY (L.H) SINGL CAPSUL		7.2500	1		1				1		7.25
73-0449	765	21	189		FA RING, 0.1732" X 3/32" #C0137YM		0.4500	4	1	4				1		1.80
73-0450	765	21	191		FA PEN ARM ASSY (PLIF RECORD)		4.2000	1		1				1		4.20
73-0451	765	21	192		FA PEN ARM ASSY (PFD RECORD) FOXB		4.2000	1		1				1		4.20
73-0452	765	21	183		FA PEN ARM ASSY (GREEN REC) FOXR		4.2000	1		1				1		4.20
73-0453	765	21	184		FA PEN ARM MOVEMENT ASSY, 3-REC.		46.0000	1		1				1		46.00
73-0454	765	21	189		FA FUSE #3/8 AMP, 100, 118V, IN PUT		0.8000	2		2				1		1.60
73-0455	765	21	190		FA PEN LIFTER ASSY, FOXBORO G010		1.7500	1		1				1		1.75
73-0456	765	21	189		FA CHART ROLL ASSY, FOXR, G0103AY		14.2500	1		1				1		14.25
73-0457	765	21	190		FA GEAR, FOXBORO, #G0103RC, DDC		1.9000	2		2				1		3.80
73-0458	765	21	189		FA PEN ASSY, PFD, FOXR, #M0147XF		13.0000	1		1				1		13.00
73-0459	765	21	190		FA MOTOR ASSY, FOXBORO, #M01321F		0.7000	1		1				1		0.70
73-0460	765	21	190		FA GEAR, FOXBORO, #G0103		1.1000	1		1				1		1.10
73-0461	765	21	233		FA GEAR, FOXBORO, #G0103FL, DDC		6.2500	1		1				1		6.25
73-0462	765	21	221		FA DRIVE ROLL ASSY, FOXBORO DDC		0.8000	1		1				1		0.80
73-0463	765	21	221		FA GEAR, FOXBORO, #G0103FC, DDC		6.2500	1		1				1		6.25
73-0464	765	21	233		FA DRIVE ROLL ASSY, FOXBORO, DDC		0.7500	1		1				1		0.75
73-0465	765	21	232		FA GEAR, FOXBORO, #G0103EK, DDC		13.0000	1		1				1		13.00
73-0466	765	21	221		FA RING, 0.916" FOXBORO G0103FP		5.8000	4	1	4				1		23.20
73-0467	765	21	221		FA MOTOR ASSY, 3/4" HR, #M0132TE		179.0000	1		1				1		179.00
73-0468	765	21	232		FA GASKET, DIAPHRAGM, FOXB, D00117T		152.0000	1		1				1		152.00
73-0469	765	21	228		FA DIAPHRAGM ASSY, #171A, 55 PLY		152.0000	1		1				1		152.00
73-0470	765	21	197		FA DIAPHRAGM ASSY, #171A, 55 PLY		2.0000	2		2				1		4.00
73-0471	765	21	220		FA DIODE, FOXBORO, #N0109F7, DDC		9.3000	1		1				1		9.30
73-0472	765	21	233		FA DIODE, FOXBORO, #N0120FK, DDC		8.7500	1		1				1		8.75
73-0473	765	21	233		FA TRANSISTOR, FOXBORO, #N0148WR		6.5000	1		1				1		6.50
73-0474	765	21	221		FA TRANSISTOR, FOXBORO, #N0119WA		192.5000	1		1				1		192.50
73-0475	765	21	227		FA AMP LIFTER, FOXBORO, #N0119XX		192.5000	1		1				1		192.50
73-0476	765	21	196		FA MOTOR FORCE ASSY, #N01019XX		192.5000	1		1				1		192.50
73-0477	765	21	220		FA GASKET, DIAPH, FOXBORO, #N0114TP		0.9500	10	3	10				2		95.00
73-0478	765	21	233		FA RING, 0. FOXR, #N0102MY, DDC		0.7500	2		2				1		1.50
73-0479	765	21	233		FA FLEXURE ASSY, FOXR, #N0114XZ		5.2500	2		2				1		10.50
73-0480	765	21	224		FA FORCE BAR ASSY, FOX, #N0119FA		35.0000	1		1				1		35.00
73-0481	765	21	215		FA DIAPHRAGM, USE W/ RING 20-205"		116.0000	2		2				1		232.00
73-0482	765	21	216		FA GASKET, FOXR, #N0102MI, DDC		1.3000	1		1				1		1.30
73-0483	765	21	216		FA RING, 0.511" CONE, FI, ASTOMETER		0.7500	1		1				1		0.75
73-0484	765	21	216		FA GASKET, TFF, FOXBORO, #N0114TP		0.9500	4	1	4				1		3.80
73-0485	765	21	216		FA NOZLE ASSY, FOXBORO, #N01021Y		3.7500	1		1				1		3.75
73-0486	765	21	216		FA RING, 0.315" FOXBORO, #N0123M2		0.6000	1		1				1		0.60
73-0487	765	21	216		FA RING, 0.178" FOXBORO, #A37744		1.3500	1		1				1		1.35
73-0488	765	21	217		FA SCREENS, FOXBORO, #N0103FP		0.3000	4	1	4				1		1.20
73-0489	765	21	217		FA RELAY, #400, FOXBORO, #C0135YM		18.0000	1		1				1		18.00
73-0490	765	21	217		FA GASKET, FOXBORO, #C01000FM		0.8750	2	1	2				1		1.75
73-0491	765	21	231		FA DIAPHRAGM ASSY, #16, 55, #N0117T		170.0000	1		1				1		170.00
73-0492	765	21	217		FA FLEXURE ASSY, #1655, #N0114XZ		5.2500	1		1				1		5.25
73-0493	765	21	217		FA DIODE, FOXBORO, #N0109FC, DDC		2.0000	3	1	3				1		6.00
73-0494	765	21	217		FA RING, 0. FOXBORO, #N0119WR		1.7000	4	1	4				1		6.80
73-0495	765	21	218		FA CAPACITOR, FOXBORO, #N0141NF		9.8500	2	1	2				1		19.70
73-0496	765	21	218		FA DIODE, FOXBORO, #N0129FK, DDC		9.5000	1		1				1		9.50
73-0497	765	21	218		FA TRANSISTOR, FOXBORO, #N0131RP		4.7500	1		1				1		4.75
73-0498	765	21	218		FA TRANSISTOR, FOXBORO, #N0141MC		9.0000	1		1				1		9.00

STOCK NUMBER	LOCATION		UI	ITEM DESCRIPTION	E	UNIT VALUE	MAX QTY.	MIN QTY.	ON HAND	REP	ON ORDER	P.O.	THIS YEAR TOTAL ISSUED	DEMAND	TOTAL ON HAND VALUE
	BLDG	SEC													
73-0499	765	21 218	FA	TRANSISTOR, FOXBORO #N0148RH		8.7500	1	1	1						8.75
73-0500	765	21 218	FA	FLEXURE, FOXBORO #N0141KT,DDC		1.0000	1	1	1						1.00
73-0501	765	21 101	FA	DETECTOR, FOXBORO #N0141LY		40.0000	1	1	1						40.00
73-0502	765	21 015	FA	MOTOR, FORCE ASSY, FOXBORO		270.0000									270.00
73-0503	765	21 102	FA	LEVER, FOXBORO #N0141EX, DDC		32.0000	1	1	1						32.00
73-0504	765	21 103	FA	DISC ASSY, FOXBORO #N0143RR		2.8500	1	1	1						2.85
73-0505	765	21 114	FA	AMPLIFIER, FOXBORO #N0143W		197.7500	1	1	1						197.75
73-0506	765	21 104	FA	RING, O. STILICONE, FLASTOMETER		0.7500	2	2	2						1.50
73-0507	765	21 115	FA	GASKET, METAL 1/16SS, FOXBORO		0.5500	6	2	6						3.30
73-0508	765	21 105	FA	GASKET, PLASTIC, TFE #D0114TP		0.9500	6	2	6						5.70
73-0509	765	21 113	FA	DIAPHRAGM ASSY, #N0101000		115.0000	2	1	2						230.00
73-0510	765	21 113	FA	DIAPHRAGM ASSY, #N0101000		115.0000	2	1	2						230.00
73-0511	765	21 106	FA	FLEXURE ASSY, FOXB, #N0114X7		5.2500	1	1	1						5.25
73-0512	765	21 107	FA	SCREEN DISC, 316SS, #D0114FL		0.5500	16	4	16						8.80
73-0513	765	21 108	FA	GASKET, TFE, FOXB, #D0114RR, DDC		0.7500	16	4	8					8	6.00
73-0514	765	21 024	FA	FUSE, FOXBORO #A20055Y, DDC		0.4900	4	2	4						1.96
73-0515	765	21 109	FA	DIODE, FOXBORO #N0109EZ, DDC		2.0000	1	1	1						2.00
73-0516	765	21 116	FA	CAPACITOR, FOXB, #K0120RC DDC		2.8500	1	1	1						2.85
73-0517	765	21 117	FA	PICTO MODULE, FOXB, #K0120PN		18.0000	1	1	1						18.00
73-0518	765	21 118	FA	INVERT 6, SUN MODULE (F/60HZ)		62.0000	1	1	1						62.00
73-0519	765	21 119	FA	DEMODULATOR, 6, OUTPUT #K0120AI		62.0000	1	1	1						62.00
73-0520	765	21 110	FA	RELAY, FOXB, #K0121, DDC		5.6000	1	1	1						5.60
73-0521	765	21 111	FA	RELAY, FOXB, #C0100ER, DDC		42.0000	2	1	2						84.00
73-0522	765	21 025	FA	GASKET, FOXB, #C0100FN, DDC		0.5500	4	2	4						2.20
73-0523	765	21 026	FA	RING, O. FOXB, #U0103BN, DDC		0.3500	4	2	2						1.40
73-0524	765	21 027	FA	RING, O. FOXB, #C0123AS, DDC		0.3000	4	2	4						1.20
73-0525	765	21 028	FA	SCREEN, FOXB, #U0103EP, DDC		0.3000	6	2	6						1.80
73-0526	765	21 029	FA	SCREEN ASSY, FOXB, #C0125AT		4.0000	2	1	2						8.00
73-0527	765	21 030	FA	NOZZLE, FOXB, #U0102FM, DDC		2.0000	1	1	1						2.00
73-0528	765	21 031	FA	CORRECTION ASSY, FOXB, #N0126CA		3.3500	1	1	1						3.35
73-0529	765	21 018	FA	MOTOR FORCE ASSY, FOXB, #N01216		235.0000	1	1	1						235.00
73-0530	765	21 032	FT	TURBINE, FOXB, #P0128AA, DDC		21.0000	4	2	4						84.00
73-0531	765	21 033	FA	RELAY (CLASS 1 DIV 1), #C0100ER		0.5500	4	2	4						2.20
73-0532	765	21 034	FA	GASKET, FOXB, #C0100EM, DDC		0.5500	8	2	8						4.40
73-0533	765	21 035	FA	RING, O. FOXB, #U0103DN, DDC		0.3500	4	2	4						1.40
73-0534	765	21 036	FA	RING, O. FOXB, #C0123AS, DDC		0.3000	18	6	18						6.30
73-0535	765	21 037	FA	SCREEN, FOXBORO, #U0103EP, DDC		0.3000	16	5	16						4.80
73-0536	765	21 051	FA	SCREEN ASSY, FOXB, #C0125AT, DDC		4.0000	4	2	4						16.00
73-0537	765	21 052	FA	PISTONS ASSY, FOXB, #N0126FC		23.0000	2	1	2						46.00
73-0538	765	21 053	FT	TURBINE, FOXB, #N0128AA, DDC		0.5000	10	3	10						5.00
73-0539	765	21 056	FA	GASKET, (CL 1 DIV) FOXB, #N0126F		1.2500	8	2	8						10.00
73-0540	765	21 054	FA	GASKET, FOXB, #U0110AX, DDC		0.6000	8	2	8						4.80
73-0541	765	21 055	FT	TURBINE, FOXB, #C0130AR, DDC		0.2500	4	2	4						1.00
73-0542	765	21 219	FA	NOZZLE, FOXB, #5683, DDC FIELD		1.7500	4	2	4						7.00
73-0543	765	00 000	EA	REGULATOR, FOXBORO, #R0110XP		22.0000	3	1	4						44.00
73-0544	765	21 224	FA	FILTER, ELEMENT, FOXB, #R0114FW		2.8500	6	2	6						17.10
73-0545	765	21 232	FA	DIAPHRAGM ASSY, FOXB, #F010285		2.0000	6	2	6						12.00
73-0546	765	21 233	FA	VALVE, INNER, FOXB, #R0102RN		1.2500	3	1	3						3.75
73-0547	765	21 229	FA	FILTER, FOXB, #R0110CM, DDC		1.8500	15	5	15						27.75
73-0548	765	21 232	FA	GASKET, FOXBORO, #R0110CC, DDC		0.6000	24	8	24						14.40
73-0549	765	21 219	FA	SPRING, VALVE, FOXB, #F0110CC		0.3000	3	1	3						1.14
73-0550	765	21 220	FA	SEAT, VALVE, FOXB, #R0102RP		0.3500	3	1	3						1.05
73-0551	765	21 230	FA	GAUGE, PRESS, MDL, MH, 2"		3.7500	3	1	3						11.25
73-0552	765	00 000	EA	STATION, DDC PACK-UP, #62HD-2"		930.0000	1	1	1						930.00
73-0553	765	21 214	FA	STATION, DDC BACKUP, #62HD-46J		860.0000	1	1	1						860.00
COMMODITY TOTAL															
															VALUE THIS MONTH
															VALUE OF 'E' ITEMS TM

STOCK NUMBER	LOCATION		UL	ITEM DESCRIPTION	E T	UNIT VALUE	MAX. QTY.	MIN. QTY.	ON HAND	REP.	ON ORDER	THIS YEAR TOTAL		TOTAL ON HAND VALUE
	BLDG.	SEC.										ISSUED	DEMAND	
73-0559	765	21 127		FA TRANSMITTER, FOXR, #10102TK.DDC		770.0000			1			1		770.00
73-0560	765	21 221		FA TRANSMITTER, FOXR, #101057M		479.0000			1			1		479.00
73-0561	765	21 223		FA TRANSMITTER, FOXR, #101057M		63.0000			1			1		63.00
73-0562	765	21 219		FA TRANSMITTER, FOXR, #101057M		0.3800		2	4			1		1.52
73-0563	765	21 219		FA RELAY, FOXR, #R0152MA.DDC		19.7500		1	1			1		19.75
73-0564	765	21 219		FA GASKET, FOXR, #C0100FM.DDC		0.5500		2	2			1		1.10
73-0565	765	21 220		FA RING, FOXR, #C0100FM.DDC		0.4300		2	1			1		.86
73-0566	765	21 220		FA SCREENS, FOXR, #10103FP		0.1000		2	1			1		.60
73-0567	765	21 220		FA GASKET, FOXR, #R0105F5.DDC		0.4400		1	1			1		.44
73-0568	765	21 220		FA GASKET, FOXR, #R0105F5.DDC		0.4400		1	1			1		.44
73-0569	765	21 259		FA TUBE, FOXR, #K0100PX.DDC		8.7500		1	1			1		8.75
73-0570	765	21 251		FA BUFFER KIT, FOXR, #C0106KN		7.7500		5	2			1		15.50
73-0571	765	21 257		FA RING, X, FOXR, #P6301RT.DDC		0.3800		18	6			5		6.84
73-0572	765	21 259		FA DIAPHRAGM, FOXR, #P0120NA.DDC		11.2500		12	4			1		135.00
73-0573	765	21 250		FA RING, X, FOXR, #R6301FT.DDC		0.3500		6	2			1		2.10
73-0574	765	21 259		FA DIAPHRAGM, FOXR, #B6301FA.DDC		8.6500		4	2			1		34.60
73-0575	765	21 253		FA KITS, SOFTWARE, SERV. 3/4"		5.0000		3	1			1		15.00
73-0576	765	21 019		FA KITS, SOFTWARE, SERV. 1 1/2"		7.0000		10	3			1		60.00
73-0577	765	21 020		FA KITS, SOFTWARE, SERV. 1 1/2"		6.0000		5	2			1		35.00
73-0578	765	21 022		FA KITS, SOFTWARE, SERVICE 1"		12.0000		5	2			1		60.00
73-0579	765	21 204		FA GASKET, FOXR, #1F5629-0402		24.8800		1	1			1		24.88
73-0580	765	21 207		FA GASKET, FOXR, #R0155AT.DDC		0.3000		4	2			1		1.20
73-0581	765	21 258		FA KIT, TFEON PCKING, #R0152RA		9.2000		1	1			1		9.20
73-0582	765	21 259		FA KIT, TFEON PCKING, #R0152RA		3.2500		2	1			2		6.50
73-0583	765	21 258		FA GASKET, FOXR, #43399.DDC		12.7500		4	2			1		9.00
73-0584	765	21 258		FA GASKET, FOXR, #43399.DDC		2.2500		2	1			1		2.25
73-0585	765	21 258		FA KIT, TFEON PCKING, FOXR, #R015		14.4500		2	1			1		27.50
73-0586	765	21 258		FA SEAL, ASSY, FOXR, #J01315X		0.9000		3	1			1		2.70
73-0587	765	21 254		FA GASKET, FOXR, #J01315X		19.2500		3	1			1		57.75
73-0588	765	21 255		FA KIT, TFEON PCKING, FOXR, #R015		13.7500		2	1			1		27.50
73-0589	765	21 258		FA SEAL, ASSY, FOXR, #J0135MA.DDC		5.6000		6	2			1		16.80
73-0590	765	21 256		FA RING, ELLED LANTERN		0.2700		6	2			1		1.62
73-0591	765	21 256		FA GASKET, FOXR, #J0135MA.DDC		7.3500		4	2			1		29.40
73-0592	765	21 258		FA KIT, PCKING, FOXR, #J0128PK		2.2500		4	2			1		9.00
73-0593	765	21 258		FA RUSHING, FOXR, #J0132PA.DDC		2.2500		4	2			2		10.50
73-0594	765	21 057		FA GASKET, FOXR, #J0136AA.DDC		2.1200		4	2			1		8.48
73-0595	765	21 058		FA RING, SCRAPER, FOXR, #J0139SW		1.7000		4	2			1		6.80
73-0596	765	21 059		FA RING, SCRAPER, FOXR, #J0139SW		1.7000		4	2			1		6.80
73-0597	765	21 060		FA KIT, TFEON PCKING, FOXR, #R015		51.0000		1	1			1		51.00
73-0598	765	21 060		FA GASKET, FOXR, #R0155AT.DDC		14.7500		1	1			1		14.75
73-0599	765	21 061		FA GASKET, FOXR, #R0155AT.DDC		14.7500		1	1			1		14.75
73-0600	765	21 061		FA RING, SCRAPER, FOXR, #J0139SW		0.7100		1	1			1		0.71
73-0601	765	21 062		FA RING, SCRAPER, FOXR, #J0139SW		0.7100		1	1			1		0.71
73-0602	765	21 063		FA RING, SCRAPER, FOXR, #J0139SW		0.7100		1	1			1		0.71
73-0603	765	21 064		FA RING, SCRAPER, FOXR, #J0139SW		0.7100		1	1			1		0.71
73-0604	765	21 065		FA RING, SCRAPER, FOXR, #J0139SW		0.7100		1	1			1		0.71
73-0605	765	21 066		FA RING, SCRAPER, FOXR, #J0139SW		0.7100		1	1			1		0.71
73-0606	765	21 067		FA RING, SCRAPER, FOXR, #J0139SW		0.7100		1	1			1		0.71
73-0607	765	21 068		FA RING, SCRAPER, FOXR, #J0139SW		0.7100		1	1			1		0.71
73-0608	765	21 069		FA RING, SCRAPER, FOXR, #J0139SW		0.7100		1	1			1		0.71
73-0609	765	21 070		FA RING, SCRAPER, FOXR, #J0139SW		0.7100		1	1			1		0.71
73-0610	765	21 071		FA RING, SCRAPER, FOXR, #J0139SW		0.7100		1	1			1		0.71
73-0611	765	21 072		FA RING, SCRAPER, FOXR, #J0139SW		0.7100		1	1			1		0.71
73-0612	765	21 073		FA RING, SCRAPER, FOXR, #J0139SW		0.7100		1	1			1		0.71
73-0613	765	21 074		FA RING, SCRAPER, FOXR, #J0139SW		0.7100		1	1			1		0.71
73-0614	765	21 075		FA RING, SCRAPER, FOXR, #J0139SW		0.7100		1	1			1		0.71
73-0615	765	21 076		FA RING, SCRAPER, FOXR, #J0139SW		0.7100		1	1			1		0.71
73-0616	765	21 077		FA RING, SCRAPER, FOXR, #J0139SW		0.7100		1	1			1		0.71
73-0617	765	21 078		FA RING, SCRAPER, FOXR, #J0139SW		0.7100		1	1			1		0.71
73-0618	765	21 079		FA RING, SCRAPER, FOXR, #J0139SW		0.7100		1	1			1		0.71
73-0619	765	21 080		FA RING, SCRAPER, FOXR, #J0139SW		0.7100		1	1			1		0.71
73-0620	765	21 081		FA RING, SCRAPER, FOXR, #J0139SW		0.7100		1	1			1		0.71
73-0621	765	21 082		FA RING, SCRAPER, FOXR, #J0139SW		0.7100		1	1			1		0.71
73-0622	765	21 083		FA RING, SCRAPER, FOXR, #J0139SW		0.7100		1	1			1		0.71
73-0623	765	21 084		FA RING, SCRAPER, FOXR, #J0139SW		0.7100		1	1			1		0.71
73-0624	765	21 085		FA RING, SCRAPER, FOXR, #J0139SW		0.7100		1	1			1		0.71
73-0625	765	21 086		FA RING, SCRAPER, FOXR, #J0139SW		0.7100		1	1			1		0.71
73-0626	765	21 087		FA RING, SCRAPER, FOXR, #J0139SW		0.7100		1	1			1		0.71
73-0627	765	21 088		FA RING, SCRAPER, FOXR, #J0139SW		0.7100		1	1			1		0.71
73-0628	765	21 089		FA RING, SCRAPER, FOXR, #J0139SW		0.7100		1	1			1		0.71
73-0629	765	21 090		FA RING, SCRAPER, FOXR, #J0139SW		0.7100		1	1			1		0.71
73-0630	765	21 091		FA RING, SCRAPER, FOXR, #J0139SW		0.7100		1	1			1		0.71
73-0631	765	21 092		FA RING, SCRAPER, FOXR, #J0139SW		0.7100		1	1			1		0.71
73-0632	765	21 093		FA RING, SCRAPER, FOXR, #J0139SW		0.7100		1	1			1		0.71
73-0633	765	21 094		FA RING, SCRAPER, FOXR, #J0139SW		0.7100		1	1			1		0.71
73-0634	765	21 095		FA RING, SCRAPER, FOXR, #J0139SW		0.7100		1	1			1		0.71
73-0635	765	21 096		FA RING, SCRAPER, FOXR, #J0139SW		0.7100		1	1			1		0.71
73-0636	765	21 097		FA RING, SCRAPER, FOXR, #J0139SW		0.7100		1	1			1		0.71
73-0637	765	21 098		FA RING, SCRAPER, FOXR, #J0139SW		0.7100		1	1			1		0.71
73-0638	765	21 099		FA RING, SCRAPER, FOXR, #J0139SW		0.7100		1	1			1		0.71
73-0639	765	21 100		FA RING, SCRAPER, FOXR, #J0139SW		0.7100		1	1			1		0.71
73-0640	765	21 101		FA RING, SCRAPER, FOXR, #J0139SW		0.7100		1	1			1		0.71
73-0641	765	21 102		FA RING, SCRAPER, FOXR, #J0139SW		0.7100		1	1			1		0.71
73-0642	765	21 103		FA RING, SCRAPER, FOXR, #J0139SW		0.7100		1	1			1		0.71
73-0643	765	21 104		FA RING, SCRAPER, FOXR, #J0139SW		0.7100		1	1			1		0.71
73-0644	765	21 105		FA RING, SCRAPER, FOXR, #J0139SW		0.7100		1	1			1		0.71
73-0645	765	21 106		FA RING, SCRAPER, FOXR, #J0139SW		0.7100		1	1			1		0.71
73-0646	765	21 107		FA RING, SCRAPER, FOXR, #J0139SW		0.7100		1	1			1		0.71
73-0647	765	21 108		FA RING, SCRAPER, FOXR, #J0139SW		0.7100		1	1			1		0.71
73-0648	765	21 109		FA RING, SCRAPER, FOXR, #J0139SW		0.7100		1	1			1		0.71
73-0649	765	21 110		FA RING, SCRAPER, FOXR, #J0139SW		0.7100		1	1			1		0.71
73-0650	765	21 111		FA RING, SCRAPER, FOXR, #J0139SW		0.7100		1	1			1		0.71
73-0651	765	21 112		FA RING, SCRAPER, FOXR, #J0139SW		0.7100		1	1			1		0.71
73-0652	765	21 113		FA RING, SCRAPER, FOXR, #J0139SW		0.7100		1	1			1		0.71
73-0653	765	21 114		FA RING, SCRAPER, FOXR, #J0139SW		0.7100		1	1			1		0.71
73-0654	765	21 115		FA RING, SCRAPER, FOXR, #J0139SW		0.7100		1	1			1		0.71
73-0655	765	21 116		FA RING, SCRAPER, FOXR, #J0139SW		0.7100		1	1			1		0.71
73-0656	765	21 117		FA RING, SCRAPER, FOXR, #J0139SW		0.7100		1	1			1		0.71
73-0657	765	21 118		FA RING, SCRAPER, FOXR, #J0139SW		0.7100		1	1			1		0.71
73-0658	765	21 119		FA RING, SCRAPER, FOXR, #J0139SW		0.7100		1	1					

STOCK NUMBER	LOCATION			UI	ITEM DESCRIPTION	E T	UNIT VALUE	MAX QTY	MIN QTY	ON HAND	REP	ON ORDER	P O	THIS YEAR TOTAL		TOTAL ON HAND VALUE
	BLDG	SEC	E N D											ISSUED	DEMAND	
73-0609	765	21	070	EA	FA RING, 0.511 CONE, #N0121EE, DDC		0.7500	2	1	2			1			1.50
73-0610	765	21	071	EA	FA RING, 0.511 CONE, #N0121EE, DDC		1.5750	1	1	1			1			1.575
73-0611	765	21	072	EA	FA RING, 0.511 CONE, #N0121EE, DDC		3.9500	2	2	2			1			3.95
73-0612	765	21	073	EA	FA FUSE, 118V, FOXR, #N0121EE, DDC		0.8000	2	2	2			1			1.60
73-0613	765	21	207	EA	FA DIODE, FOXR, #N0109EZ, DDC		2.0000	1	1	1			1			2.00
73-0614	765	21	208	EA	FA DIODE, FOXR, #N0109EZ, DDC		0.6500	2	2	2			1			1.30
73-0615	765	21	208	EA	FA DIODE, FOXR, #N0120HN, DDC		9.3000	1	1	1			1			9.30
73-0616	765	21	208	EA	FA TRANSISTOR, FOXR, #N0128CY, DDC		5.1000	1	1	1			1			5.10
73-0617	765	21	208	EA	FA TRANSISTOR, FOXR, #N0128ET, DDC		17.5000	1	1	1			1			17.50
73-0618	765	21	208	EA	FA TRANSISTOR, FOXR, #N0128ET, DDC		0.8000	1	1	1			1			0.80
73-0619	765	21	208	EA	FA DIODE, FOXR, #N0109EZ, DDC		2.0000	1	1	1			1			2.00
73-0620	765	21	209	EA	FA RING, 0.511 CONE, #N01194R, DDC		1.7000	1	1	1			1			1.70
73-0621	765	21	209	EA	FA SCREEN, DISC, FOXR, #N0116KP		0.3000	4	2	4			1			1.20
73-0622	765	21	209	EA	FA RING, 0.511 CONE, FOXR, #N0116KP		0.6000	1	1	1			1			0.60
73-0623	765	21	209	EA	FA RING, 0.511 CONE, FOXR, #N0116KP		0.4400	1	1	1			1			0.44
73-0624	765	21	209	EA	FA RING, 0.511 CONE, FOXR, #N0116KP		0.7500	1	1	1			1			0.75
73-0625	765	21	209	EA	FA STRAINER, FOXR, #R01027P, DDC		1.4000	4	2	4			1			5.60
73-0626	765	21	214	EA	FA RECORDER, 6430HF-0-A, TREND		1210.0000	1	1	1			1			1,210.00
73-0627	765	21	038	EA	FA STATION, AUTO-MAN, #7HD-F5, J6-		555.0000	2	2	2			1			1,110.00
73-0628	765	21	202	EA	FA STATION, AUTO-MAN, #7HD-F5, J6-		555.0000	6	6	6			1			3,330.00
73-0629	765	21	194	EA	FA TRANSMITTER, D/P CELL, FLCP		720.0000	2	2	2			1			1,440.00
73-0630	765	21	100	EA	FA TRANSMITTER, D/P CELL, FLCP		625.0000	2	2	2			1			1,250.00
73-0631	765	21	159	EA	FA TRANSMITTER, P/PS, #FLGM-HSAA		538.0000	1	1	1			1			538.00
73-0632	765	21	200	EA	FA CONVERTER, RESISTANCE, TO-CURR		335.0000	5	5	5			1			1,675.00
73-0633	765	21	123	EA	FA CONVERTER, PH TO CURRENT		805.0000	2	2	2			2			1,610.00
73-0634	765	21	210	EA	FA CONVERTER, PH TO CURRENT		390.0000	2	2	2			1			780.00
73-0635	765	21	013	EA	FA TRANSMITTER, CP, P/PS, POSITION		220.0000	1	1	1			1			220.00
73-0636	765	21	267	EA	FA POSITIONER, TYPE C, VALVACTOR		135.0000	5	2	6			1			675.00
73-0637	765	21	194	EA	FA ACTUATOR, 4V, VALVE, 1/2" SS		305.0000	1	1	1			1			305.00
73-0638	765	21	124	EA	FA VALVE, V9000, 1" SS, BODY & BALL		325.0000	1	1	1			1			325.00
73-0639	765	21	234	EA	FA VALVE, V9000, 1 1/2" CAST STI.		545.0000	6	6	6			1			3,270.00
73-0640	765	21	158	EA	FA VALVE, VI STEM GUIDED, 1" SS		395.0000	2	2	2			1			790.00
73-0641	765	21	012	EA	FA VALVE, V9000, 3/4" CAST STI.		210.0000	1	1	1			1			210.00
73-0642	765	21	156	EA	FA VALVE, V1STEM, GUIDED, 1" SS		290.0000	1	1	1			1			290.00
73-0643	765	21	265	EA	FA SWITCH, MERCROID, P/PS, #DAH-31		135.0000	1	1	1			1			135.00
73-0644	765	21	000	EA	FA SWITCH, MERCROID, #DAH-21-103		243.0000	1	1	1			1			243.00
73-0645	765	21	234	EA	FA SOLENOID, 1/2" WAY, 120 VAC		29.5000	4	2	3			1			118.00
73-0646	765	21	234	EA	FA SOLENOID, 1/2" WAY, 24VDC, SKINNER		34.5000	1	1	1			1			34.50
73-0647	765	21	264	EA	FA POSITIONER, CURRENT, TO-AIR		272.5000	1	1	1			1			272.50
73-0648	765	21	151	EA	FA TRANSDUCER, CURRENT, TO-AIR		195.0000	2	1	2			6			390.00
73-0649	765	21	151	EA	FA TRANSDUCER, CURRENT, TO-AIR		105.0000	2	1	2			2			210.00
73-0650	765	21	155	EA	FA MANIFOLD, RM-M4V5, ANDERSON		84.0000	1	1	1			1			84.00
73-0651	765	21	125	EA	FA DISPLACER, 3" X 1/4" SS F/RUOYANC		84.0000	1	1	1			1			84.00
73-0652	765	21	266	EA	FA DISPLACER, 2.47" X 1/4", 316 SS		58.0000	3	3	3			1			174.00
73-0653	765	21	017	EA	FA SWITCH, LIMIT, DPDT NEMA-7		161.5000	1	1	1			1			161.50
73-0654	765	21	018	EA	FA VALVACTOR, TYPE C, W/R/FASS		140.0000	2	1	2			2			280.00
73-0655	765	21	213	EA	FA PUR BS, EXP, PROOF DYNATHERN		175.0000	1	1	1			1			175.00
73-0656	765	21	211	EA	FA GAUGE, 6" MA, SURFACE MOUNT		39.0000	2	1	2			1			78.00
73-0657	765	21	152	EA	FA THERMOMETER, ASHCROFT, #50-6060		160.0000	1	1	1			1			160.00
73-0658	765	21	151	EA	FA THERMOMETER, ASHCROFT, #50-6060A		299.2000	2	2	2			1			598.40
73-0659	765	21	260	EA	FA SWITCH, MERCROID, TEMP, #DAH		330.4000	1	1	1			1			330.40
73-0660	765	21	263	EA	FA FLANGE, 6" 150# SS, FOXR, DDC		500.8800	1	1	1			1			500.88
73-0661	765	21	263	EA	FA FLANGE, 6" 150# SS, FOXR, DDC		182.8300	2	1	2			2			365.66
73-0662	765	21	154	EA	FA SWITCH, MERCROID, #DAH-41-103-R-		182.8300	1	1	1			1			182.83

VALUE THIS MONTH

VALUE OF 'E' ITEMS TM

VALUE LAST MONTH

COMMODITY TOTAL

STOCK NUMBER	LOCATION			UL	ITEM DESCRIPTION	E I T	UNIT VALUE	MAX QTY	MIN QTY	ON HAND	REP.	ON ORDER	THIS YEAR TOTAL		TOTAL ON HAND VALUE
	BUD	SEC	IN										ISSUED	DEMAND	
73-0665	765	21	171		FA-SOL-MAGNETIC PICK-UP ELECTRO		245.0000						1		490.00
73-0666	765	21	201		FA-SWITCH-RECORDER LIGHTS LEVEL		644.7500						1		644.75
73-0667	765	21	084		EA POTENTIOMETER, FOXB, #N0221FM		4.5000	5	2	5					22.50
73-0668	765	21	085		EA POTENTIOMETER, FOXB, #N0221CW		3.1000	5	2	5					15.50
73-0669	765	21	086		EA POTENTIOMETER, FOXB, #N0120SS		6.2000	5	2	5					31.00
73-0670	765	21	082		EA RELAY, FOXB, #N01967N, MDL 62HD		18.5000	5	2	5					92.50
73-0671	765	21	087		EA SWITCH, FOXB, #N0230FX, MDL 62HD		1.4000	5	2	5					7.00
73-0672	765	21	079		EA SWITCH, FOXB, #N0230E7, DDC		7.5000	5	2	5					37.50
73-0673	765	21	080		FA SWITCH, FOXB, #N0110XE, 62 HD		1.2500	5	2	5					6.25
73-0674	765	21	081		FA SWITCH, FOXB, #N0231MP, 62 HD		20.2500	5	2	5					101.25
73-0675	765	21	077		EA METER, OUTPUT, FOXB, #N0196CY		51.0000	5	2	5					255.00
73-0676	765	21	000		EA DEVIATION, FOXB, MDL 62HD, DDC		48.0000	5	2	5					240.00
73-0677	765	21	078		EA METER, FOXB, #N01965C, MDL 62HD		0.9333	40	10	45					41.99
73-0678	765	21	088		EA FUSE, FOXB, #N0121FF, MDL 62HD		0.9333	40	10	45					41.99
73-0679	765	21	089		EA FUSE, FOXBORD #N0124T5, 62 HD		0.6200	25	5	25					15.50
73-0680	765	21	090		EA POTENTIOMETER, FOXB, #N0196CN		5.9500	5	2	5					29.75
73-0681	765	21	083		EA POTENTIOMETER, FOXB, #N0196CM		3.6500	5	2	5					18.25
73-0682	765	21	000		EA-ROK-PL-JUNCTION, FOXBORD, 00101		40.0000			12					480.00
73-0683	765	21	261		EA CONTROL, SERVICE KIT, ELECT.		250.0000			1					500.00
73-0684	765	21	004		FA-VALVE-3-CIR-MODUL-VIC-1264		155.0000			1					455.00
73-0685	765	21	008		EA-ACTUATOR, FOXBORD, 0110F		140.0000			1					140.00
73-0686	765	21	111		FA-SWITCH, MAGNETROL FLOAT-5CRB,		535.0000			1					535.30
73-0687	DDC	05	405		FA FUSE 4710 AMP, RUSS TYPE GMW		0.5000	50	25	10		40	1		6.00
73-0688	DDC	05	390		FA FUSE LAMP, 250V, SLOW BLOW #1		1.0000	20	10	13					13.00
73-0689	DDC	05	391		EA FUSE, 10 AMP, 250V, SLOW BLOW #10		1.0000	10	5	10					10.00
73-0690	DDC	05	392		FA FUSE, 200 AMP, 250V, (KA200)		18.0000	10	5	5				5	90.00
73-0691	DDC	05	393		EA FUSE, 150 AMP, 250V, (A25X150)		0.0000	10	5	5				3	3.00
73-0692	DDC	05	394		EA FUSE, 350 AMP, 250V, (A25X350)		12.1000	10	5	15			1		182.70
73-0693	DDC	05	395		FA LAMP, 2RV, T13/4 (327)		2.0000	6	2	5					10.00
73-0694	DDC	05	396		EA THYRISTOR, IMP, T, WEST, T6200		116.0000	8	4	8					928.00
73-0695	DDC	05	397		FA THYRISTOR, OUTPUT SWITCHING GF		184.0000	4	2	4					736.00
73-0696	DDC	05	398		FA THYRISTOR, OUTPUT COMMUTATION		102.0000	4	2	4					408.00
73-0697	DDC	05	399		EA RECTIFIER, 100A, 600V, 101K160S2		88.0000	4	2	4					352.00
73-0698	DDC	05	400		EA DIODE, 1 A.P., 600V, 11N4005		0.5000	10	4	10					5.00
73-0699	DDC	05	401		FA TRANSISTOR, NPN-POWER (2N3766)		5.0000	1	1	1					5.00
73-0700	DDC	05	402		EA RESISTOR, ASSY, (050-016-021-2		72.0000	1	1	1					72.00
73-0701	DDC	05	407		EA BOARD, EXTENDER, 043-016-4007		52.0000			1					52.00
73-0702	DDC	05	000		EA RESISTOR, 25 OHM, 225W (I270-0901		13.0000			1					13.00
73-0703	DDC	05	409		EA RESISTOR, 500 OHM, 225W		13.0000			1					13.00
73-0704	DDC	05	000		EA CONTROL, MODULC ASSY, 172-016-		3537.0000								3537.00
73-0705	DDC	05	000		EA INVERTER, SWITCHING BRIDGE		2644.0000								2644.00
73-0706	DDC	05	406		FA SWITCH, STATIC POWER MODULF		627.0000							1	627.00
73-0707	DDC	05	414		FA RECTIFIER, INPUT MODULE ASSY,		2062.0000			1			1	1	2,062.00
73-0708	DDC	05	411		FA SWITCH, STATIC, CONTROL ASSY,		1209.0000			1					1209.00
73-0709	DDC	05	000		EA FILTER, DC INPUT ASSY		883.0000			1					883.00
73-0710	DDC	05	413		EA FILTER, OUTPUT ASSY, 097-016-AD		373.0000			1					373.00
73-0711	DDC	05	412		EA CAPACITOR, RANK ASSY, 060-016-A		297.0000			1					297.00
73-0712	DDC	05	408		EA CARLE DRIVE ASSY, 050-026-0012		96.0000			1					96.00
73-0713	DDC	05	000		FA TRAY, PAPER, TAPF, RIUF 36-05364		3.0000	12	6	12			1		36.00
73-0714	DDC	05	410		EA COVER, VINYL, CLIFAR, NO SPILL		1.0000	12	6	12					12.00
73-0715	DDC	05	000		EA FANFOLD, DEC 36-05363-01		58.0000	4	2	4					232.00
73-0716	DDC	05	404		EA RTBON, TTY, DEC 18-09137-01		20.0000	2	1	2					40.00
73-0717					RELAY, DC ALLEN BRADLEY 700DC		38.0000			2					76.00
73-0718	765	21	305		FA LAMP, G.E. 1R43, MINIATURE 2RV		0.5440	20	10	20					10.88
73-0719	765	21	306		EA LAMP, G.E. #327, SINGLE CONTACT		0.3120	20	10	20					6.24

STOCK NUMBER	LOCATION			UI	ITEM DESCRIPTION	E	T	UNIT VALUE	MAX. QTY.	MIN. QTY.	ON HAND	REP.	ON ORDER	THIS YEAR TOTAL		TOTAL ON HAND VALUE
	BLDG	SEC	B.N.											NO.	ISSUED	
73-0720-765-00-000					EA-STEM-6-PLUG-ALLOY-20x1/2-V-1			0.0000	1							0.00
73-0721-765-21-900					EA-SEAT-RING-ALLOY-20x1/2-V-1			0.0000	1							0.00
73-0722-765-00-000					EA-STEM-6-PLUG-ALLOY-20x1/2-V-1			0.0000	3	1						0.00
73-0723-765-21-301					EA-STEM-6-PLUG-ALLOY-20x1/2-V-1			0.0000	1							0.00
73-0724-765-21-304					EA-SEAT-RING-ALLOY-20x1/2-V-1			0.0000	5	3						0.00
73-0725-765-21-302					EA-GASKET-SET-FF-101848FN			0.0000	5							0.00
73-0726-765-21-303					EA-GASKET-SPRAL-V-316-5x5x1/16			0.0000	5	3						0.00
COMMODITY TOTAL														VALUE THIS MONTH	88,814.95	
														VALUE OF 'E' ITEMS TM		
														VALUE LAST MONTH		

APPENDIX A

EQUIPMENT MANUALS FOR SELECTED NON-FOXBORO INSTRUMENTS

## EQUIPMENT MANUALS FOR SELECTED NON-FOXBORO INSTRUMENTS

This appendix contains manufacturers literature for five of the manufacturers supplying equipment for the control system. Pertinent maintenance information for the various components begins on the pages as listed below.

<u>Manufacturer</u>	<u>Component</u>	<u>Page</u>
Anderson Greenwood	3-Valve Manifold	A1-3
Electro Corproation	Magnetic Pickups	A2-2
Mercoid Corporation	Temperature Switch	A3-3
	Pressure Switch	A3-6
	Liquid Level Controls Series 301	A3-10
	Liquid Level Controls Series 401	A3-13
Magnetrol Division	Liquid Level Controls	A4-3, A4-20
Skinner	Electric Solenoid Valves	A5-2

APPENDIX A-1

ANDERSON GREENWOOD 3-VALVE MANIFOLDS

ANDERSON, GREENWOOD & CO.

REPORT NUMBER  
2-0175-68-7

OPERATION, MAINTENANCE & REPAIR  
INSTRUMENT SHUTOFF VALVES AND MANIFOLDS

Prepared by:

*M. Schomer*

Approved by:

*J. F. Weise*

QAM

*Paul C. [unclear]*

Date:

2-20-1973

SCOPE: This procedure is applicable to single valves and multiple-valve instrument manifolds.

### 1.0 INSTALLATION

- 1.1 Install valves in the system with flow in the direction indicated by flow arrow. If no flow arrow is stamped on the valve body, flow may be in either direction.
- 1.2 Valves with weld ends to be welded per specifications of facility in which they are to be installed.
- 1.3 Pipe connections must be made up tight, with a thread sealant or seal weld.
- 1.4 Manifolds with mounting holes shall be bolted to adequate supporting structure.

### 2.0 OPERATION

- 2.1 In closed position valve should be seated at 4 to 5 ft. lbs.
- 2.2 In open position valve may be back seated at approximately 5 ft. lbs.

### 3.0 MAINTENANCE AND REPAIR

- 3.1 If stem packing should develop a leak, tighten the packing nut, the minimum amount required to stop the leak. Overtightening shortens the packing life.
- 3.2 If packing needs replacing, emergency replacement may be accomplished by backseating stem in full open position.
  - 3.2.1 Remove handle by loosening handle bolt.
  - 3.2.2 Remove packing nut and follower, then three packing rings, and washer.
  - 3.2.3 Insert a small amount of lubricant into packing cavity followed by washer, three rings of packing, then follower and nut. Tighten nut to 50 inch lbs. See assembly drawing for approved lubricant.
  - 3.2.4 Install handle and tighten screw against flat spot on stem to 12 ft. lbs.
  - 3.2.5 Unseat stem from backseat position and check for leakage. Tighten packing nut additionally if required to stop leak.
- 3.3 If conditions allow removal of bonnet assembly for repair, it is preferable to do so.
  - 3.3.1 Remove roll pin, then unscrew bonnet from body.

- 3.3.2 Dismantle bonnet assembly and clean thoroughly with Acetone or Alcohol.
- 3.3.3 Inspect parts for damage; particularly stem threads and ball end. Replace both stem and bonnet if threads do not engage smoothly.
- 3.3.4 Lubricate threads thoroughly with the lubricant specified on the respective assembly drawing.
- 3.3.5 Reassemble per drawing on page 4, replacing old packing with new packing.
- 3.3.6 Install roll pin to lock bonnet after bonnet has been properly torqued into body.

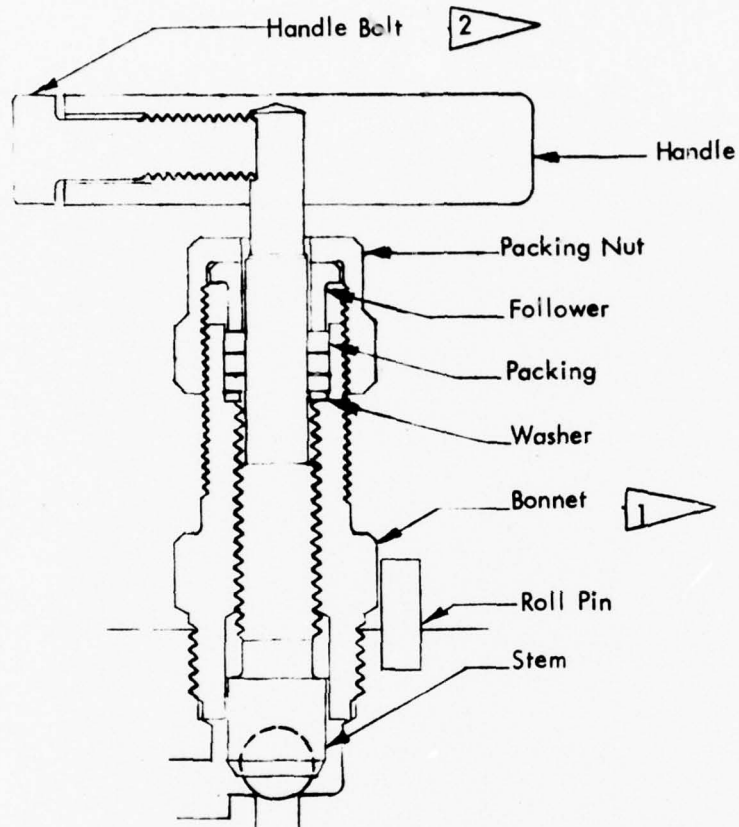

1 Bonnet installation torque 30 to 35 ft. lbs.

2 Handle bolt torque 12 to 15 ft. lbs.

Refer to the respective assembly drawing for part numbers.

APPENDIX A-2

ELECTRO CORPORATION MAGNETIC PICKUPS



# MAGNETIC PICKUP HANDBOOK

52.065B

Rev. 3-1-65

## ELECTRO MAGNETIC PICKUPS

### INSTALLATION

Provide a mounting with a threaded hole.

Models 3070, 3075 require a  $\frac{3}{4}$ "-20 UNEF thread.

Models 3010-A, 3010-AN, 3010-HTB, 3030, 3030-AN, 3030-HTB, 3040-A, 3045-A, 3110-A and 3114 require a  $\frac{5}{8}$ "-18 UNF thread.

Models 3015-A, 3015-HTB, 3016 and 3025 require a  $\frac{3}{8}$ "-24 UNF thread.

Models 3053, 3055-A and 3056 require a  $\frac{1}{4}$ "-40 NS thread.

Screw the pickup into the mounting and adjust for a clearance of approximately .005" between the pole piece and the actuating device. This clearance is an arbitrary value and may be altered as conditions require. Output voltage decreases rapidly with increased clearance. Lock the pickup securely in position with the jam nut.

Connect the pickup output to your instrument or controlling device. (See diagrams for cable connections.)

### ADJUSTMENT

The only adjustment required is the clearance between the pickup and the actuating medium. Make sure there is sufficient clearance to prevent damaging the pickup. The recommended procedure is to advance the pickup until it touches the actuating device (while at rest), then backing off the pickup by a known amount.

The  $\frac{3}{4}$ "-20 thread advances .0500" per turn.

The  $\frac{5}{8}$ "-18 thread advances .0555" per turn.

The  $\frac{3}{8}$ "-24 thread advances .0415" per turn.

The  $\frac{1}{4}$ "-40 thread advances .025" per turn.

The output of the pickup varies inversely with the clearance for a given speed, therefore, for maximum output use the smallest clearance possible. In most applications the pickup output is more than adequate. In these instances, the output may be reduced by increasing the clearance. (See graphs #69.037 and #69.038.)

### GENERAL INFORMATION

The ELECTRO magnetic pickup will produce a voltage output when any magnetic material moves near the pole piece at the end of the pickup. The exciting material may be iron or steel which is attracted by a magnet. This includes all castings, bars, forgings and sheet steel with the exception of a few of the stainless-steel alloys which are not magnetic. When it is desired to operate the pickups from devices made of brass, aluminum or other non-magnetic metals, a steel screw or slug may be inserted in the non-magnetic metal for exciting the pickups.

The magnetic pickup makes use of what is known as "stray magnetic field", so no provision for "return magnetic

circuits or paths is necessary. Any device which produces a dynamic discontinuity of magnetic material in the field of the pickup will produce an electrical voltage. This may be a vibrating surface, moving bar, crank, gear teeth, wheel spokes, or a steel screw-head mounted on some moving surface. While the pickups may be excited by a keyway or a slot in a wheel, there is likely to be an unwanted background signal due to varying density or eccentricity of the material. It is better, therefore, to excite the pickup from a protrusion on the surface. This places the pickup at a relatively great distance from the materials between excitation periods and it is less likely to pick up stray signals.

### OUTPUT

The ELECTRO magnetic pickup is a rate-of-change device. The output voltage depends on the rate of change in its magnetic field. There are three factors involved.

1. The peripheral speed.
2. The size of the gear teeth or actuating mass.
3. The distance away from the pickup.

**1. PERIPHERAL SPEED** When calculating the peripheral speed of a gear it is necessary to know the outside diameter of the gear. If this can't be measured, it may be found by dividing the number of teeth + 2 by the pitch. Thus, a 78-tooth, 20-pitch gear would be  $78 + 2 = 20$  or 4 inches in diameter.

The output voltage varies directly with the speed in a nearly linear manner. Varying the clearance produces an output voltage variation tending to be inversely proportional to the clearance squared. With either factor held constant, the output will be entirely controlled by the other.

**2. GEAR SIZES** The tooth size is usually indicated by "DIAMETRAL PITCH", or, in common usage, just pitch, such as a 10-pitch or a 20-pitch gear. The tooth size is large for low pitch numbers and small for high pitch numbers. For instance, an 8-pitch gear has very large teeth measuring about  $\frac{3}{4}$ " of an inch from center-to-center along the outside circumference, while 48-pitch teeth measure about  $\frac{1}{8}$ " inch on centers.

With any given speed and clearance conditions, a maximum power output will result when the field is filled with a relatively infinite mass of magnetic material at one instant and a complete absence of such material the next. A reasonable approach to these conditions exists when the cross-section of the exciting masses is equal or greater than that of the pole piece and the space between is equal or greater than three times the pole piece.

**ELECTRO PRODUCTS LABORATORIES, inc.**

6125 N. HOWARD ST. CHICAGO, ILL. NO. 5 60649/775-5220/AREA 312/T.W.X. 312-967-5162/CABLE-ELECTROLAB

OUTPUT (cont'd.)

**MODIFIED POLE PIECE SHAPES**

When using gears with finer than optimum pitch, the projected portion of a pole piece may be shaped to a cone or chisel shape to offset some of the voltage loss shown in Table I above.



Figure 2A

Figure 2

Figure 2B

In Figure 2 above, it is shown how turning or filing a pole piece to a smaller end area can permit use of a gear with finer teeth. End area is critical in determining amount of voltage which may be generated. A sharp point Figure 2A offers greatly reduced voltage and may be worse than a cylindrical end if the gear is not extremely fine-toothed. A blunt chisel point such as illustrated in Figure 2B can produce much more voltage.

**TYPICAL PERFORMANCE CHARACTERISTICS FOR COMMON POLE PIECE CONFIGURATIONS**

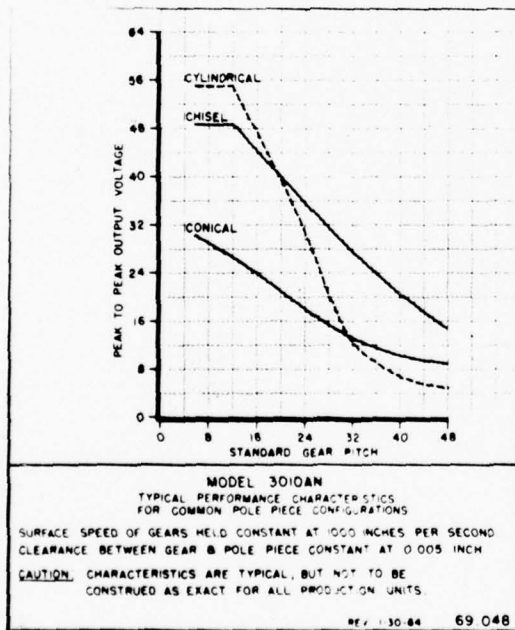

**CONDITIONS OF TESTS**

Surface speed of gears held constant at 1000 ips, clearance between gear and pole piece constant at 0.005".

NOTE: Characteristics are typical, but not to be construed as exact for all production units.

Graph 69048 shows the relationship between the cylindrical shaped end and the conical shaped and chisel shaped ends as voltage producers. Note that for gears of 20-pitch to approximately 28-pitch, a chisel-shape would be preferred but a cylindrical shape would be better than a conical shape. For gears with teeth finer than 28-pitch, a conical shape offers some improvement over a cylindrical shape, but the chisel-shape is still preferred.

**CHISEL SHAPED POLE PIECE**

**Advantage** - Higher output voltage for given size gear teeth than conical shaped pole piece.

**Disadvantage** - Difficult to adjust spacing of pickup without upsetting orientation of chisel point with respect to gear teeth.

**CONICAL SHAPED POLE PIECE**

**Advantages** - a) Shape is easily produced

b) Pickup may be screwed in or out to desired spacing without problem of pole piece orientation.

**Disadvantages** - a) Lower output voltage for given size gear than with a chisel shaped pole piece.

b) End diameter is critical in determining amount of voltage which may be generated. Physical tolerances on end diameter and pole piece projection length become extremely tight making it difficult to produce a unit with predictable output.

**LOAD**

These pickups will deliver maximum power to loads of 1,000 to 1,500 ohms. For maximum voltage the load should be 10,000 ohms or over. (See graphs #69.001, 69.002, 69.003, and 69.004.)

**WAVE SHAPE**

Gears with 10-pitch teeth or smaller will produce a near sine wave output. Larger teeth or projections having large spaces between them will produce a series of pulses having very sharp peaks at both positive and negative extremes. (See figure 3.)

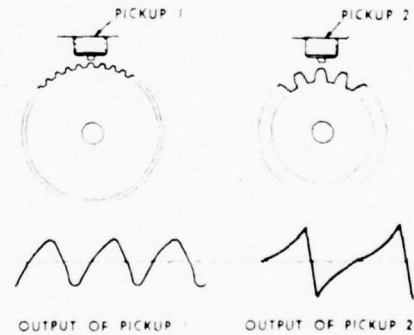

Figure 3

Output waveforms produced by fine and coarse-tooth gears.

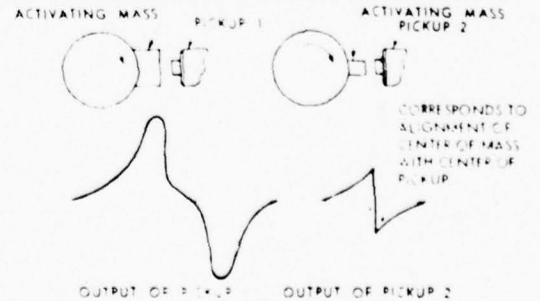

Figure 4

Outputs produced by two sizes of single activating masses.

OUTPUT (cont'd.)

The optimum tooth size and spacing for the maximum output of magnetic pickups is shown in Figure 1.

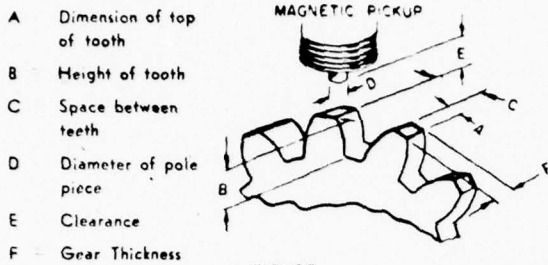

FIGURE 1

In Figure 1, the optimum dimension of (A), (B), and (C), are given as they relate to (D) the diameter of the pole piece of the magnetic pickup being used. The optimum relationship for maximum output is as follows:

- (A) equal to or greater than (D)
- (B) equal to or greater than (C)
- (C) equal to or greater than three times (D)
- (E) as close as possible; typically .005" or less
- (F) equal to or greater than (D)

The above configuration is not available in a stock gear but it is seldom necessary to have the maximum output. Very close to the maximum output may be generated by conventional stock gears if the tooth width "A", Figure 1, is equal to or greater than the pickup pole piece diameter "D". Gear thickness is not critical as long as it is equal to or greater than the pole piece diameter. For ease of alignment, the thickness should be 2 or 3 times the pole piece diameter.

The spacing between the pole piece and any magnetic material between "dwell" periods should be equal to or greater than the pole piece dimension. These conditions are approximated when using a standard gear with teeth having a diametral pitch of 8 or less. Such large tooth gears are necessary only when maximum output is desired. A small-toothed gear is usually satisfactory. A 20-pitch gear produces a useful output at surface speeds of 10" per second or over, while at high speeds a 96-pitch gear may be satisfactory.

TABLE I

MODEL #	3040-A	3114	3010-A 3010-AN 3030 3030-AN 3030-HTB 3110-A 3010-HTB	3015-HTB 3015-A 3016 3025	3045-A	3053 3056 3055-A
POLE PIECE DIAMETER	.187"	.106" (blind)	.106"	.093"	.042" (chisel)	.040"
Recommended Gear Size	VOLTAGE AVAILABLE					
6 Pitch	100%	100%	100%	100%	100%	100%
8 Pitch	90%	95%	100%	100%	98%	100%
10 Pitch	80%	89%	100%	100%	96%	100%
12 Pitch	75%	81%	100%	100%	94%	100%
16 Pitch	30%	64%	50%	100%	90%	100%
20 Pitch	15%	45%	70%	80%	82%	100%
24 Pitch	.....	29%	50%	60%	72%	100%
32 Pitch	.....	9%	20%	30%	47%	90%
48 Pitch	.....	3%	10%	5%	15%	60%

In Table I above, pole piece diameters of the various models of Electro magnetic pickups are given with gear pitches recommended for maximum output.

3. DISTANCE AWAY FROM THE PICKUP Graph 69.037 and 69.038 show the approximate percentage of voltage available with different spacings using .005" as a standard clearance for 100% output.

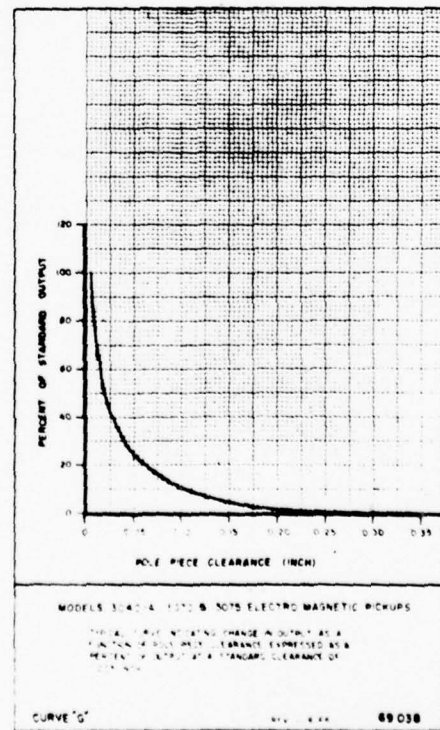
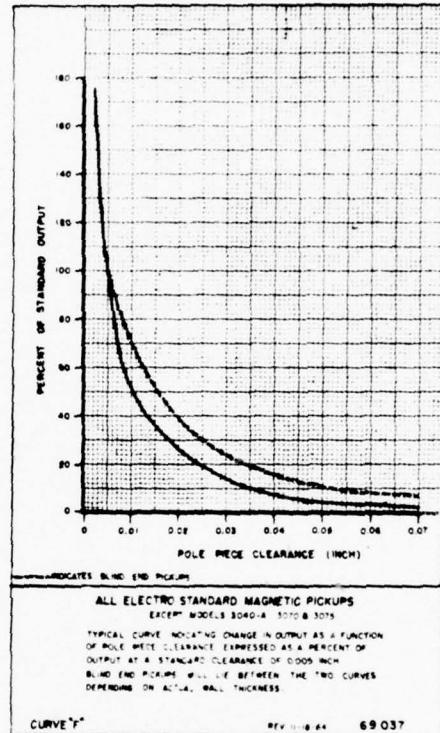

A large mass having an appreciable "dwell" time will produce a sharp positive peak when approaching the pickup and a sharp negative peak when leaving. (See figure 4.) The polarity relations may be reversed by reversing the pickup leads.

#### NON-MAGNETIC BARRIERS

The magnetic pickups may be excited through thin sections of any non-metallic substance. With non-metallic separators, the output will be affected only by the increased clearance due to the thickness of the material. Metallic separators between the pickup and the actuating means may reduce the output appreciably, depending on electrical conductivity of the material. (See figure 5.)

There will be a loss in output from two factors. First, there will be a loss because the pickup clearance has been increased by the thickness of the separating material. The reduction of output may be minimized by inserting a soft steel pin through the non-magnetic metal and pressing the pickup pole piece against this pin. (See figure 6.)

The second factor is the eddy current effect. When a pickup is excited through a metallic wall, the metal of the wall behaves like a shorted turn inserted between the pickup and actuating device. Circulating currents are induced in this wall. These create a secondary magnetic field opposing that of the exciter and reduces the current in the pickup. This shorted turn effect is of only minor importance at low frequencies but becomes very serious above 5 or 6 kc. At this point, the output begins to drop off as the speed is increased, but output seldom drops to zero.

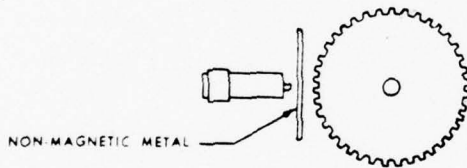

Figure 5

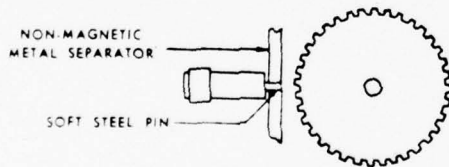

Figure 6

Placing a barrier between the pickup and the exciting means is sometimes desirable because of the presence of undesirable liquids or gases, or as a seal against pressure. Such procedure will also permit blowing air around the pickup for cooling.

#### STRAY MAGNETIC FIELDS

These pickups are well-shielded from stray fields except for those which may be in the actuating metal which moves near the pole piece. Furthermore, the voltage output is so great that no precautions are usually necessary. If, however, exceptionally strong AC magnetic fields are known to be present, the pickup should be located as far as possible from the source of any such fields. In extreme cases the unit may be demagnetized by AC fields or DC fields of demagnetizing polarity.

#### AMBIENT OPERATING CONDITIONS

Pickups may be operated under conditions where oil, water or non-corrosive liquids are present. Care should be taken to see that the connector is sealed by taping or other means. While these pickups are sealed against moisture, etc., and will usually withstand pressure of several atmospheres, they are not recommended for high pressure work. Special pickups can be provided for high pressure conditions.

Standard pickups will operate at ambient temperatures up to 225°F. (105°C.). The "HTB" series and 3055-A pickups will operate at ambient temperatures up to 450°F. (232°C.). The 3100 series will operate at ambient temperatures to 800°F. (427°C.).

#### WARRANTY

ELECTRO PRODUCTS LABORATORIES warrants each pickup manufactured by them to be free of defects in material and workmanship for a period of one-year from date of sale to original purchaser. We will repair or replace, at no-charge, any pickup returned to the factory and determined by us to be defective. Pickups found to be damaged, or when reason for defect is not the fault of the manufacturer, will be replaced at standard costs.

If returning pickups, pack carefully and ship prepaid. Enclose information as to reason for return and be sure to include your return address.

#### CABLE CONNECTIONS

EPL CABLE ASSEMBLIES 30-N, 30-NL, 32-N, 30N BNC

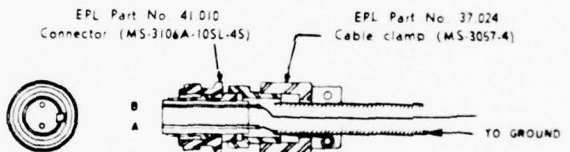

Standard single wire shielded cable. Pin "A" grounded to shield and to connector.

#### OTHER POSSIBLE CONNECTIONS

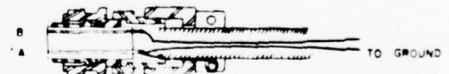

Two wire shielded cable. Pin "A" grounded to shield and connector.

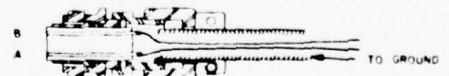

Two wire shielded cable. Grounded connector and ungrounded leads.

#### EPL TYPE MD CABLE ASSEMBLY



Single wire shielded cable with connector shell grounded to shield.

OUTPUT (cont'd.)

### OUTPUT CALCULATIONS

The following nomograph, 69050, has been prepared to give quick calculations of:

1. Gear Sizes
2. Gear Surface Speeds (Peripheral Speed) from RPM
3. Expected Voltages at Various Speeds
4. Frequencies Generated

#### 1. DETERMINATION OF GEAR SIZE

For the greatest accuracy in a digital counting application, the number of teeth in the gear should be a maximum. Referring to Table I, you will see that for the greatest output voltage in analog applications, the size of the teeth should not be less than 24 diametral pitch for the smaller pickups (3055-A). The larger pickups require a larger sized tooth for maximum voltage output. Note that a gear of 12 diametral pitch has the smallest tooth that will give 100% output from the 3010 Series pickups.

Nomograph columns (1), (2) and (3) are used to determine the relationship between diametral pitch, number of teeth and outside diameter (not pitch diameter) of a gear. Using a straight edge, connect points on any two of the columns representing known quantities. The intersection of the edge and the third column will give the desired value. For example: If a 5-inch O.D. gear (col. 3) has 100 teeth (col. 1), it can be determined from column (2) that it will be a 20 diametral pitch gear. Or, given a 60-tooth gear (col. 1) of 24 diametral pitch (col. 2), it can be determined that the O.D. will be approximately 2.7 inches from column (3). Similarly, with given diameter and pitch, the number of teeth in a gear can be determined. The gear teeth illustrated with the nomograph are actual size.

#### 2. GEAR SURFACE SPEEDS FROM RPM OR RPS

Connecting the appropriate point on the gear diameter column (3) and the shaft speed in RPM (4) or RPS (5) and extending this line to the surface speed column (6) will determine the surface speed of the gear in inches/second.

For example: A 2" diameter gear (col. 3) turning at 200 RPM (col. 4) has a surface speed of 20" per second (col. 6).

#### 3. DETERMINATION OUTPUT VOLTAGE FOR A GIVEN MODEL MAGNETIC PICKUP

The output voltage from a magnetic pickup is directly proportional to the surface speed of the periphery of the actuating gear. (This is under the condition that the input impedance of the connected circuit is at least 10 times the internal impedance of the magnetic pickup at the highest operating speed.) An estimate of the output voltage for any given pickup model can then be obtained by connecting the point just obtained on the surface speed column (6) to the model in question in column (10). The intersection of this line with the voltage column (8) will indicate the output of that pickup.

Knowledge of the threshold voltage required to operate the indicating device will then allow you to determine the lowest shaft speed at which the indicator can be used reliably by working the steps given above in reverse order.

**Note:** Voltage calculations are based on standard test conditions for each pickup model as listed in Specification Sheet 58081, and may not hold true under conditions of extremely high frequency (50 KC +) or load impedances of less than 10 times pickup internal impedance.

#### 4. DETERMINING APPROXIMATE OUTPUT FREQUENCY

With a given gear surface speed (col. 6) and the diametral pitch of the gear (col. 9) — the same value as determined from column (2) — the output frequency of a pickup can be determined from the frequency column (7). This calculation is less exact than the others because of the simplifying assumptions made to reduce the number of nomograph columns. Multiplying the number of teeth in the gear by the shaft speed in RPS gives the exact frequency.

#### VALUES BEYOND THE RANGE OF THE NOMOGRAPH

Each column of the nomograph contains at least two full logarithmic cycles. Multiplying any scale by factors of ten and carrying the multiplying factor along in the answer will allow calculations of any magnitude.

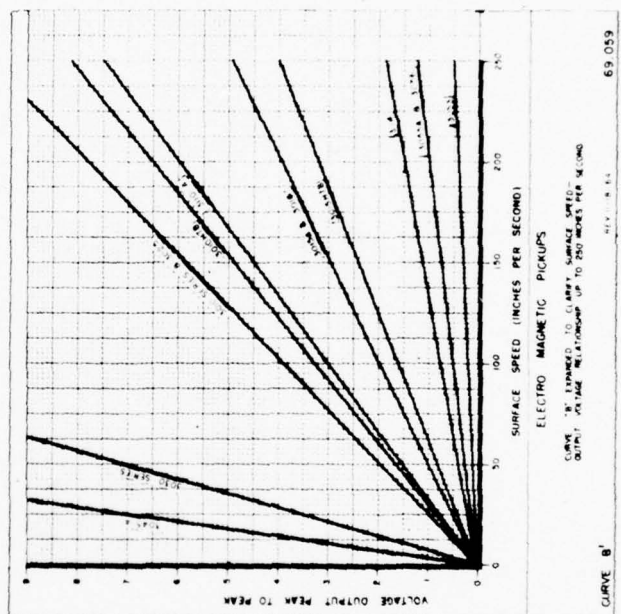
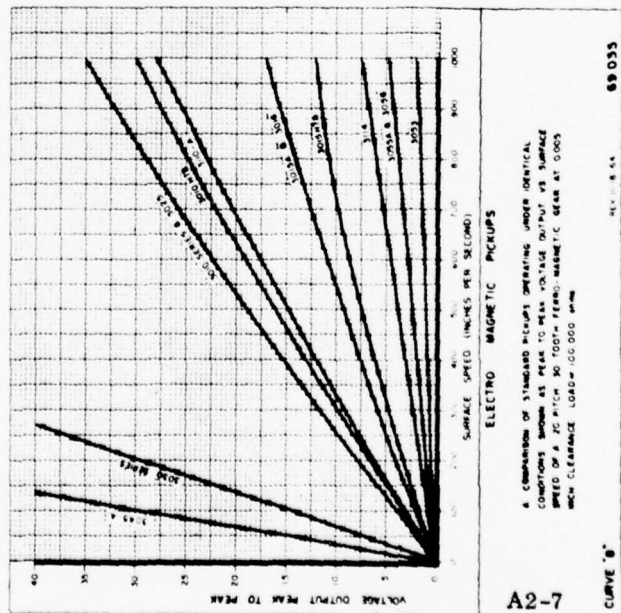
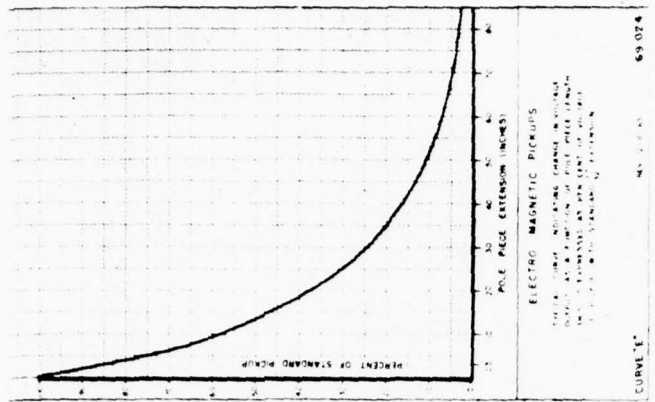
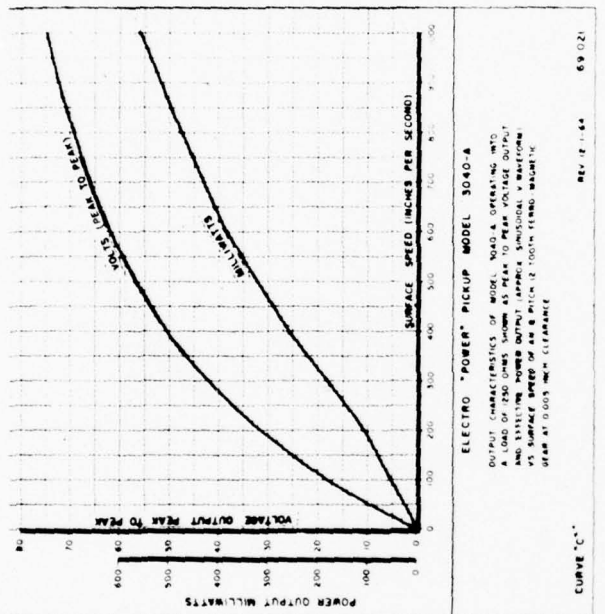
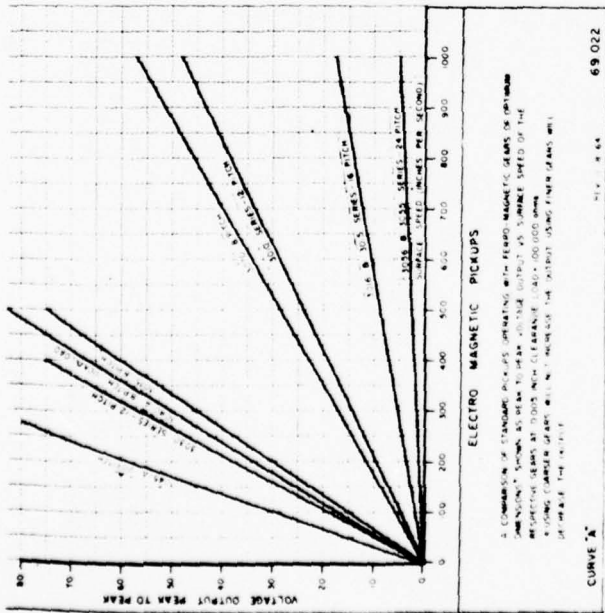

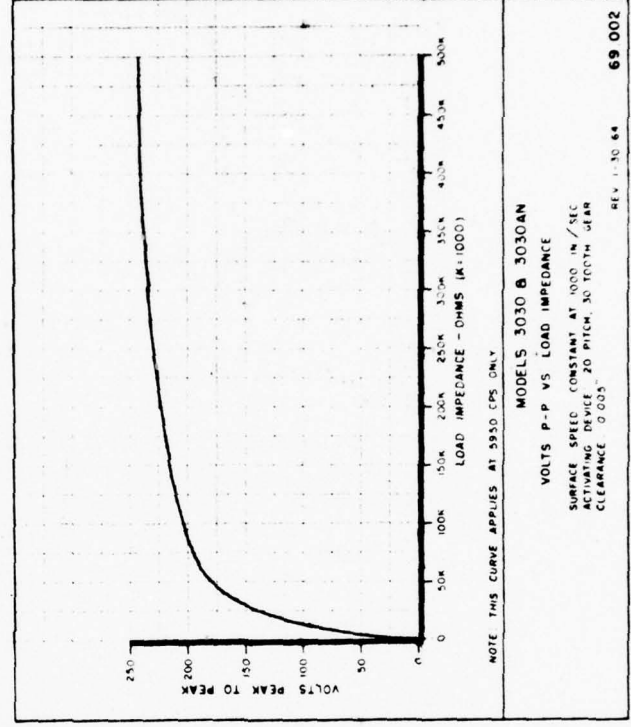
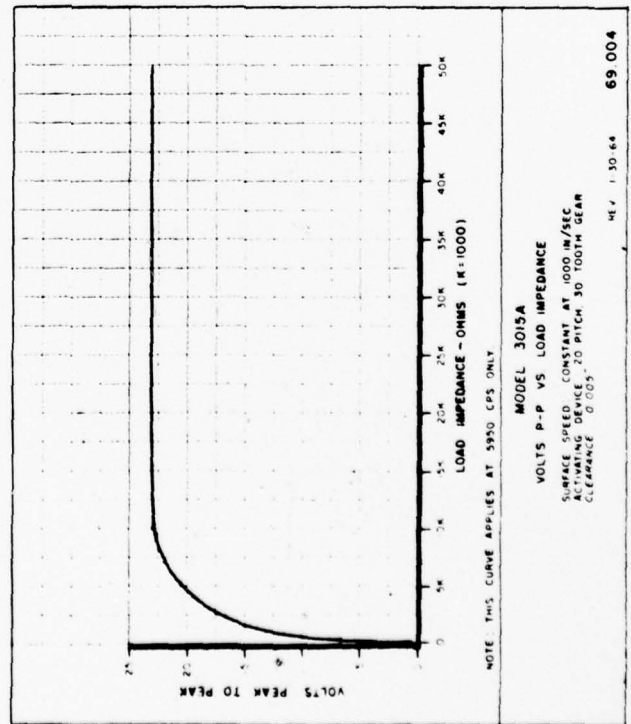
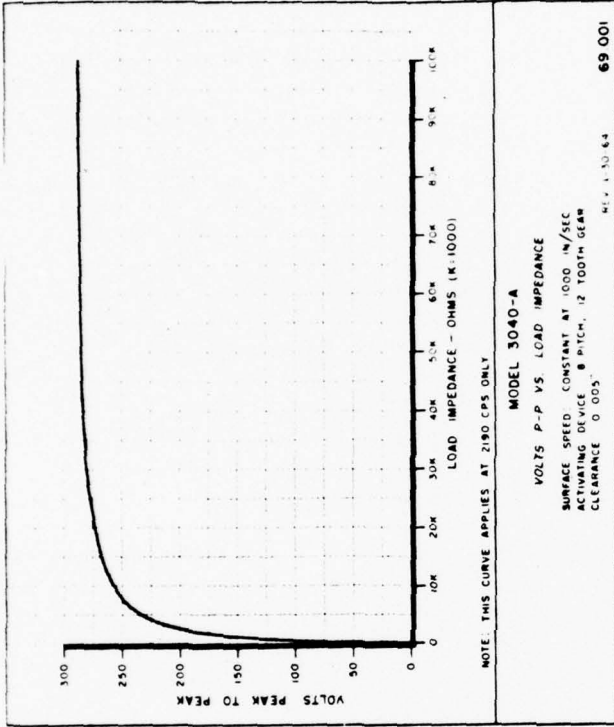
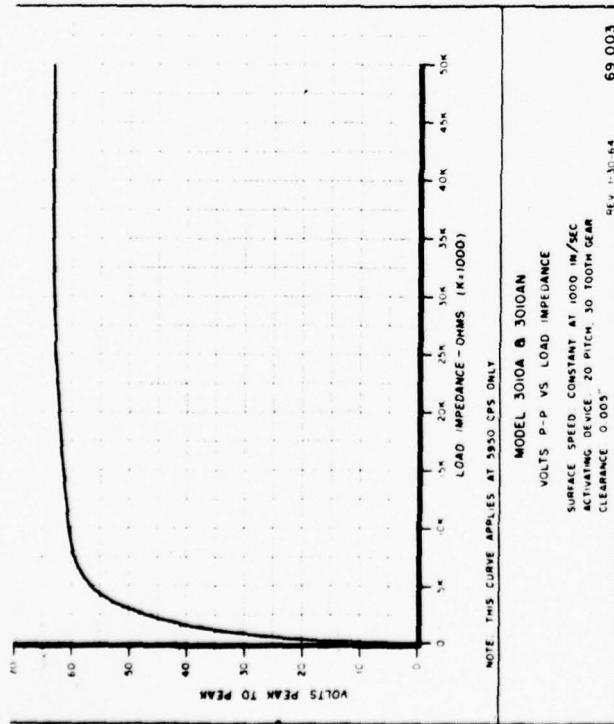

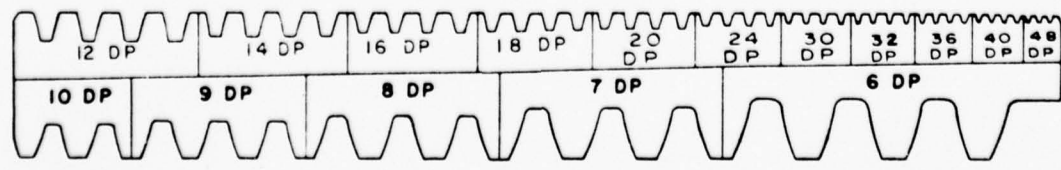
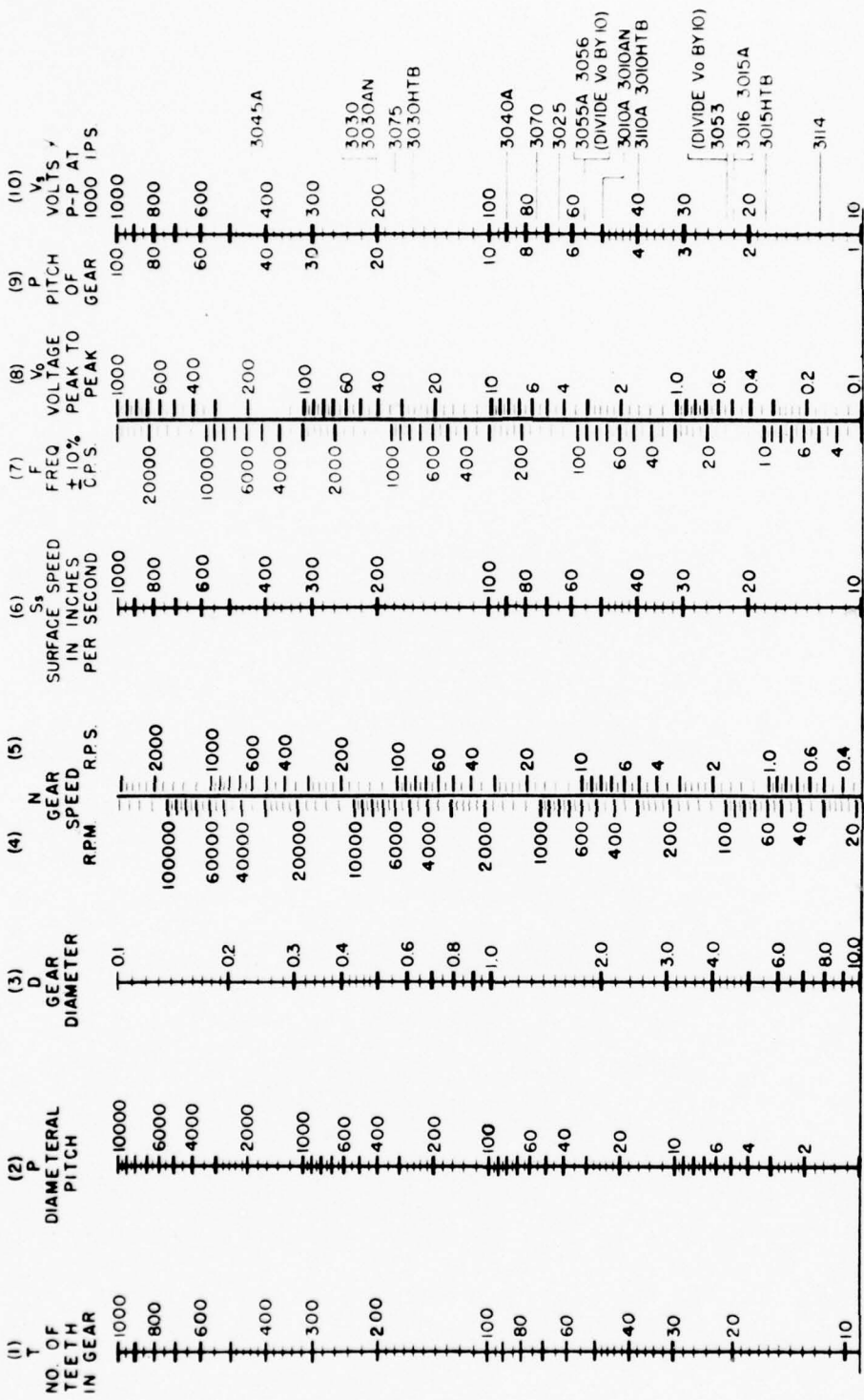

ACTUAL SIZE

COPYRIGHT 1965  
ELECTRO PRODUCTS LABS INC

$F \approx \frac{Ss \cdot P}{T}$   
 $F = N \cdot RPS \cdot T$   
 $F = T \cdot \frac{Ss}{T \cdot D}$

$F = \frac{T \cdot Ss}{T \cdot D} \left( \frac{P}{T+2} \right) = \left( \frac{T}{T+2} \right) \frac{Ss \cdot P}{T}$

NOTE: VALUES OF "F" ARE DECREASED 10% ON THE SCALE TO AVERAGE THE ERROR FROM ASSUMING  $\frac{T}{T+2} = 1$

\* TYPICAL OUTPUT VOLTAGE FOR PICKUP MODELS. SEE SPECIFICATION SHEET 58.084 FOR TEST VOLTAGE LIMITS.

69050



600497  
5/19/75

## OPERATING INSTRUCTIONS

MINI-TACH MODELS 75399-75407

### GENERAL

The Electro Mini-Tach is a plug-in Frequency to DC Converter designed primarily to accept inputs from magnetic pickups and to provide 0-1mA to drive a meter, or 0-5V DC for other applications. Nine standard units are available to cover the full scale input frequency ranges from 50Hz to 20000Hz. These models are packaged in a high impact plastic case on a 12 pin industrial plug-in base, for ease of installation and replacement.

### MOUNTING

The Mini-Tach models plug in to the Electro Model 58390 socket, which is held to the panel by two screws. The socket provides screw terminals for connecting wiring. Details are shown in Figure 1. Mounting orientation is unimportant, but the top of the module should be easily accessible if adjustments will be made when installed.

### WIRING CHART

TERMINAL	FUNCTION	TERMINAL	FUNCTION
1	NC	12	NC
2	NC	11	NC
3	+12VDC Output	10	0-5V Output
4	COMMON	9	0-1mA Output
5	AC LINE	8	Input Signal
6	AC LINE	7	Input Common

### OPERATION

Apply power and an input signal. The unit will then furnish an output which is linearly proportional to frequency over the range of 0-1mA or 0-5 volts. Both outputs may be used simultaneously subject to the following conditions:

- A. The load resistance applied to the voltage output should be greater than 50K ohms.
- B. The load on the current output should be present continuously. Therefore, if the current output is used with a

**ELECTRO CORPORATION**

1845 57TH STREET, SARASOTA, FLORIDA 33580 • AREA CODE 813 • 355 8411 • TELEX 5-2683

A2-10

portable or switched instrument, the output should be short circuited when the instrument is removed. This can be achieved by using a shorting jack, or switch.

- C. The unit should be recalibrated with both loads applied. Factory calibration is performed using the current output only.

The voltage output may be used alone with any load resistance exceeding 5000 ohms. The output ripple will increase as the load resistance increases, especially with the low frequency models. It is recommended that if the load resistance exceeds 50K ohms, the current output terminal be shorted to common to provide a proper termination for the output filter, and the unit be recalibrated.

When used with a magnetic pickup speed sensor, the input frequency is determined as follows:

$$F = \frac{RN}{60} \quad \text{When } F = \text{frequency in hertz}$$

N = number of teeth on the rotating actuator

R = speed in RPM

Thus, it is convenient to use 60 tooth actuators, since then  $F = R$ .

#### SPECIFICATIONS

<u>Input Signal</u>	1 volt peak positive, any waveform, to 22V RMS or 10mA max.
<u>Input Impedance</u>	2200 ohms resistive
<u>Output Signal</u>	A. Current output - 0 to 1mA DC full scale into 50 ohms load max. B. Voltage output - 0 to 5VDC full scale into 5000 ohms load (min.) C. Output is directly proportional to input frequency.
<u>Power Supplied</u>	12.6V DC at 10mA to supply active sensors such as Di-Mag
<u>Power Requirements</u>	115VAC, 60Hz 3 Watts
<u>Line Voltage Stability</u>	A 10% change in line voltage causes an output error no greater than 0.5%
<u>Linearity</u>	Within $\pm 0.25\%$ of full scale
<u>Accuracy</u>	$\pm 0.5\%$ of full scale
<u>Temperature Range</u>	-40°F (-40°C) to +162°F (70°C)

### FREQUENCY RANGE

<u>MODEL</u>	<u>STANDARD RANGE</u>	<u>ADJUSTMENT RANGE</u>
75399	0 - 50	45 - 100
75400	0 - 100	90 - 180
75401	0 - 250	180 - 750
75402	0 - 500	450 - 950
75403	0 - 1000	950 - 2000
75404	0 - 2500	2300 - 4500
75405	0 - 5000	4500 - 9000
75406	0 - 10000	5500 - 20000
75407	0 - 20000	10000 - 40000

### CALIBRATION

The Mini-Tach may be calibrated or adjusted by means of a multiturn potentiometer accessible through the hole plug in the top of the case. Connect a known frequency of at least 1 volt peak amplitude to the input terminals, and a suitable indicator to one (or both) of the outputs (see "Operation" regarding use of both outputs). Adjust the output so that the reading on the indicator(s) is appropriate for the given frequency. Thus, suppose that the desired full scale frequency is 100 Hertz, and the available calibration signal is 60 Hertz, the indicator should read 60% of full scale. Calibration should always be performed using a frequency of 60% of full scale or more.

### TROUBLE SHOOTING

In the event of an apparent malfunction, check that the input signal is present at the right amplitude, and that the output load is normal. (This can be done by interchanging a good module.) In case of erratic behaviour, monitor the 12V DC supply (pins 3 and 4), this should be a constant voltage of about 13 volts nominal value. If it is low or erratic, check the AC line voltage, and if this is correct, return the unit for repair.

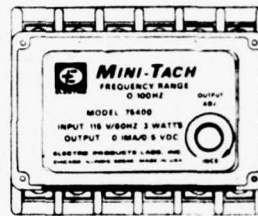
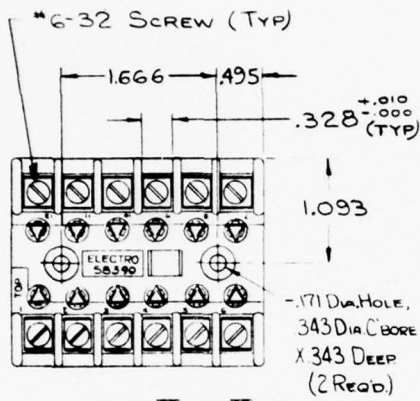

VIEW A-A

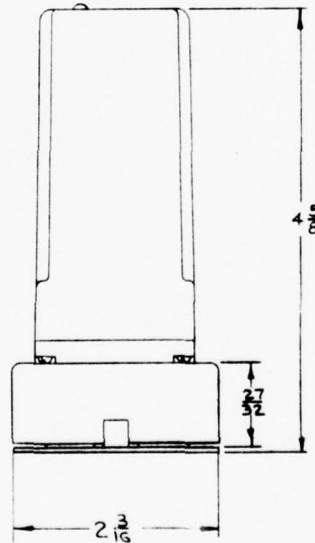
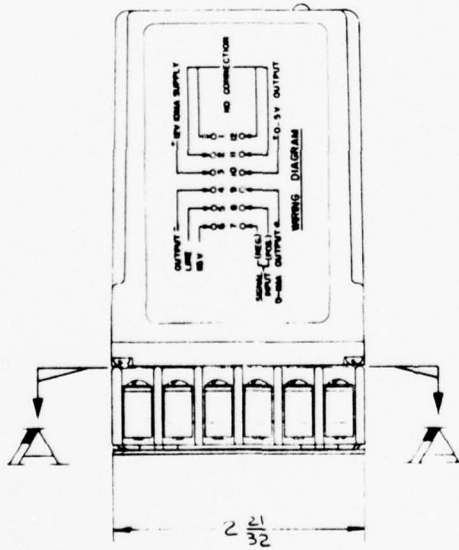



52.106  
6-21-65

## OPERATING INSTRUCTIONS

SPECIAL INSTRUCTIONS FOR  
MODELS 3070 AND 3075 MAGNETIC PICKUPS  
LISTED WITH UL FOR USE IN  
HAZARADOUS LOCATIONS CLASS I GROUP D

### INSTALLATION

Installation of Models 3070 and 3075 magnetic pickups in Class I Group D hazardous locations requires the use of appropriate conduit fittings. They are provided with a 1/2" internal pipe thread fitting to accommodate rigid conduit or conduit fittings, and they are provided with 18 inch leads of #18AWG stranded wire for field splicing in conduit boxes suitable for the application.

Models 3070 and 3075 require a 3/4-20-UNEF threaded mounting hole or 3/4" clearance hole.

### SPECIAL OPERATING INSTRUCTIONS FOR INSTALLATION IN HAZARDOUS LOCATIONS

Installation adjustments of spacing to exciter gear or adjustment of load impedance must insure that the magnetic pickup does not generate voltage higher than the allowable 95 V RMS (or the equivalent 270 V peak-to-peak) under any normal or anticipated fault condition.

Maximum current rating for Models 3070 and 3075 will not be exceeded under any load condition if the 95 V RMS (or 270 V peak-to-peak) is not exceeded.

See paragraphs "Adjustment" and "Output" of Magnetic Pickup Operating Instructions 52.065B attached to determine voltage output to be expected under anticipated operating conditions. Curve 69.038 is applicable to determine effects of spacing variation.

Whenever possible the installation adjustments should be verified by operating the equipment before the equipment is installed in the "hazardous location" environment.

1 of 8

**ELECTRO CORPORATION**

1845 57TH STREET, SARASOTA, FLORIDA 33580/355-8411/AREA 813/FAX: JMG/CABLE-ELECTROLAB

A2-14

CAUTIONS

Do not connect magnetic pickups to source of power; magnetic pickups are self generating devices and do not require external power. Application of external power may result in burned out coils.  
(Non-repairable)

Do not exceed temperature ratings.

When internal power dissipation combines with ambient temperature conditions to raise case temperatures above 200° F, excessive deterioration of coil insulation will result.

Exposure to lower than rated temperatures (operating, in transit, or storage) may result in the coil becoming discontinuous (non-repairable).

Prior to opening any of the conduit points or fittings within the hazardous location area, measure the magnetic pickup output voltage at the instrumentation terminals. Do not open any fittings if voltage is present at the terminals. The equipment on which the magnetic pickup is installed must be stopped to discontinue generation of an output signal.

NOTE: THE FOLLOWING INFORMATION IS EXCERPTED FROM THE CODE DIGEST BULLETIN 2750 "HOW TO COMPLY WITH NATIONAL ELECTRICAL CODE REQUIREMENTS FOR HAZARDOUS LOCATIONS" PUBLISHED BY THE CROUSE-HINDS COMPANY.

CONDITIONS CAUSING HAZARD

A Class I location is defined as one in which flammable gases or vapors exist in quantities sufficient to render the atmosphere explosive or ignitable. The words "quantities sufficient" immediately raise the question: "What quantity of such liquid will produce a dangerous atmospheric condition?"

It is rarely possible to answer either of these questions easily or categorically. Many factors, some of them variable, are involved: temperature, barometric pressure, humidity, ventilation, ratio of volume of room to amount of liquid being vaporized, processes used, and construction of utilization equipment.

Portable gas analyzers are available which will show, with acceptable accuracy, the percentage of gas or vapor in the air at the instant the measurements are made. However, because of the likelihood of a change in one or several of the factors mentioned, dependence for safety on such data is apt to be dangerous. Then too, this method can only be used on actual installations in operation, not on contemplated installations.

Many users of gases and volatile flammable liquids are not aware that a relatively low ratio of gas or vapor to air results in an explosive mixture. Under favorable conditions, a very small quantity of the hazardous gas or liquid can create a hazardous location. The probability that the concentration may be above the upper limits should never be considered as affording any degree of safety. In order to reach the upper limit, the concentration must first pass through the explosive range! Should a source of ignition exist or come into being when the concentration is between its explosive limits an explosion is the almost certain result. The electrical source of ignition may be an arc, a spark, or excessively hot apparatus.

#### SELECTION OF EXPLOSION-PROOF EQUIPMENT

In order to determine the type of equipment needed for a particular location, it is first necessary to classify the gases and liquids used according to Article 500 of the National Electrical Code. The explosive atmospheres are divided into groups A, B, C, and D according to the characteristics of the gas or vapor involved. In selecting a device, care should be used to make sure that it is suitable for the group or groups involved in the hazardous location.

Devices suitable for use in Class I locations are not necessarily suitable for Classes II and III. Many of them are suitable, but if so, usually they are so listed. It is possible that a device suitable for Class I locations would, when blanketed by dust, overheat in a Class II location, or the presence of dust might interfere with safe operation in some other way. Devices listed for Class II have been investigated and found to be safe for use in atmospheres containing hazardous dusts. Care should be taken in selecting the correct equipment for each location.

MAXIMUM PERMISSIBLE TEMPERATURES FOR NEC CLASS I  
AND CLASS II HAZARADOUS LOCATION EQUIPMENT

Class I, Division 1. Maximum exterior temperatures in 40° C. ambient as previously established by UL.

Group A - 280° C. (536° F.)    Group C - 180° C. (356° F.)  
Group B - 280° C. (536° F.)    Group D - 280° C. (536° F.)

Class I, Division 2. \*Maximum interior 80% ignition temperature on lamps resistors, coils, etc., i.e., other than with arcing interior devices.

Group A - 240° C. (464° F.)    Group C - 144° C. (291° F.)  
Group B - 468° C. (874° F.)    Group D - 224° C. (435° F.)

\*General NEC grouping - for other specific vapors, refer to NFPA data on ignition temperatures using 80% of the degree Centrigrade ignition temperature. Consideration must be given to the actual ambient temperature condition.

WIRING METHOD - CLASS I, DIVISION 1

501-4. WIRING METHODS. Wiring methods shall conform to the following:

(a) CLASS I, DIVISION 1. In Class I, Division 1 locations, threaded rigid metal conduit or Type M1 cable with termination fittings approved for the location shall be the wiring method employed. All boxes, fittings, and joints shall be threaded for connection to conduit or cable terminations, and shall be explosion-proof. Threaded joints shall be made up with at least five threads fully engaged. Type M1 cable shall be installed and supported in a manner to avoid tensile stress at the termination fittings. Where necessary to employ flexible connections, as at motor terminals, flexible fittings approved for Class I locations (explosion-proof) shall be used.

(b) CLASS I, DIVISION 2. In Class I, Division 2 locations threaded rigid metal conduit or Type M1 cable with termination fittings approved for Class I locations shall be the wiring method employed. Type M1 cable shall be installed in a manner to avoid tensile stress at the termination fittings. Where provision must be made for limited flexibility, as at motor terminals, flexible metal fittings, flexible metal conduit

with approved fittings, or flexible cord approved for extra hard usage and provided with approved bushed fittings shall be used. An additional conductor for grounding shall be included in the flexible cord unless other acceptable means of grounding are provided.

501-5. SEALING. Seals are provided in conduit systems to prevent the passage of gases, vapors or flames from one portion of the electrical installation to another through the conduit. Such communication through Type M1 cable is inherently prevented by construction of the cable, but sealing compound is used in cable termination fittings to exclude moisture and other fluids from the cable insulation, and shall be of a type approved for the conditions of use. Seals in conduit systems shall conform to the following:

(a) CLASS I, DIVISION 1. In Class I, Division 1 locations, seals shall be located as follows:

(1) In each conduit run entering an enclosure for switches, circuit-breakers, fuses, relays, resistors or other apparatus which may produce arcs, sparks or high temperatures. Seals shall be placed as close as practicable and in no case more than 18 inches from such enclosures.

(2) In each conduit run of 2-inch size or larger entering the enclosure or fitting housing terminals, splices or taps, and within 18 inches of such enclosure or fitting.

Where two or more enclosures for which seals are required under Sections 501-5 (a-1,2) are connected by nipples or by runs of conduit not more than 36 inches long, a single seal in each such nipple connection or run of conduit would be sufficient if located not more than 18 inches from either enclosure. Ordinary conduit fittings of the "L", "T", or "Cross" type would not usually be classed as enclosures when not larger than the trade size of the conduit.

(3) In each conduit run leaving the Class I, Division 1 hazardous area. The sealing fitting may be located on either side of the boundary of such hazardous area, but shall be so designed and installed that any gases or vapors which may enter the conduit system, within the Division 1 hazardous area, will not enter or be communicated to the conduit beyond the seal. There shall be no union, coupling, box or fitting in the conduit between the sealing fitting and the point at which the conduit leaves the Division 1 hazardous area.

(b) CLASS I, DIVISION 2. In Class I, Division 2 locations, seals shall be located as follows:

(1) For conduit connections to enclosures which are required to be approved for Class I locations, seals shall be provided in conformance to Sections 501-5 (a-1,2). All portions of the conduit run or nipple between the seal and such enclosure shall conform to Section 501-4 (a).

(2) In each conduit run passing from the Class I, Division 2 hazardous area into a non-hazardous area. The sealing fitting may be located on either side of the boundary of such hazardous area, but shall be so designed and installed that any gases or vapors which may enter the conduit system, within the Division 2 hazardous area, will not enter or be communicated to the conduit beyond the seal. Rigid conduit shall be used between the sealing fitting and the point at which the conduit leaves the hazardous area, and a threaded connection shall be used at the sealing fitting. There shall be no union, coupling, box or fitting in the conduit between the sealing fitting and the point at which the conduit leaves the hazardous area.

(c) CLASS I, DIVISION 1 and 2. Where seals are required, they shall conform to the following:

(1) FITTINGS. Enclosures for connections or for equipment shall be provided with approved integral means for sealing, or sealing fittings approved for Class I locations shall be used.

(2) COMPOUND. Sealing compound shall be approved for the purpose, shall not be affected by the surrounding atmosphere or liquids, and shall not have a melting point of less than 93° C. (200° F.).

(3) THICKNESS OF COMPOUND. In the completed seal, the minimum thickness of the sealing compound shall be not less than the trade size of the conduit, and in no case less than 5/8 inch,

(4) SPLICES AND TAPS. Splices and taps shall not be made in fittings intended only for sealing with compound, nor shall other fittings in which splices or taps are made be filled with compound.

(5) DRAINAGE. Where there is probability that liquid or other condensed vapor may be trapped within enclosures for control equipment or at any point in the raceway system, approved means shall be provided to prevent accumulation or to permit periodic draining of such liquid or condensed vapor.

(6) MOTORS AND GENERATORS. Where the authority enforcing this Code judges that there is probability that liquid or condensed vapor may accumulate within motors or generators, joints and conduit systems shall be arranged to minimize entrance of liquid. If means to prevent accumulation or to permit periodic draining are judged necessary, such means shall be provided at the time of manufacture, and shall be deemed an integral part of the machine.

(7) ASSEMBLIES. In an assembly where equipment which may produce arcs, sparks or high temperatures is located in a compartment separate from the compartment containing splices or taps, and an integral seal is provided where conductors pass from one compartment to the other, the entire assembly shall be approved for Class I locations. Seals in conduit connections to the compartment containing splices or taps shall be provided in Class I, Division 1 locations where required by Section 501-5 (a-2).

#### WIRING METHOD - CLASS I, DIVISION 2

In Class I, Division 2 locations either rigid conduit or Type M1 cable with termination fittings approved for Class I locations must be used. The junction and pull boxes need not be explosion-proof. There are many types of junction and pull Condulet (R) boxes suitable for Division 2 locations (501-4 (b)). Where provision must be made for limited flexibility, Crouse-Hinds Type EBY heavy-duty cord connector may be used.

#### SEALING CLASS I, DIVISION 1 and 2

Seals are required for the purpose stated in 501-5 and for the prevention of precompression or "pressure piling" of vapors or gases in conduit systems. Several types of sealing Condulet fittings are available from Crouse-Hinds. Some may be used only in vertical conduit runs, others may be used in either vertical or horizontal runs.

52.106  
6-21-65

Note that in Division 2, the conduit between the seal and the explosion-proof enclosure must be rigid conduit with threaded joints - this because threadless connections are not flame-tight. (501-5 (b) 2).

Ordinary pothead or transformer compounds are not suitable for seals in Class I locations. They have neither the strength nor sealing characteristics necessary. Use only Crouse-Hinds Chico A sealing compound with sealing Condulet fittings.

Splices and Taps must not be made in sealing Condulet fittings as they are not designed for this purpose; neither should splices or taps in other fittings be covered by compound. (501-5 (b) 4).

In vertical conduit runs where water accumulation is probable, Crouse-Hinds types EYD or EZD drain seals should be used. They provide continuous draining and prevent water accumulation, which impairs conductor insulation (501-5 (b) 5). If water accumulation is probable in horizontal conduit runs, conduit should be graded away from seals to enclosures where Crouse-Hinds Type ECD breather-drains are installed.

APPENDIX A-3

MERCOID CORPORATION

TEMPERATURE SWITCHES, PRESSURE SWITCHES, AND LIQUID LEVEL CONTROLS

**MERCOID SERIES "D" REMOTE BULB TEMPERATURE CONTROLS**

(The following instructions apply to all Mercoïd Remote Bulb Temperature Controls prefixed by letter "D")

**ENCLOSURES—TYPE NO. PREFIX**



**CONTROL NUMBERS**

Part of the control number following Type No. Prefix identifies the style of the control case.

The digit 5 of 35,235,435,535 denotes a plain case with bottom connection. The digit 8 of 38,238,438,538 denotes a flanged case with bottom connection. The digit 9 of 39,239,439,539 denotes a flanged case with back connection.

**CIRCUITS (SWITCH OPERATION)**

Suffix number after control number denotes number of circuits and circuit operation. Examples: TYPE DA-35-2 suffix -2 indicates circuit is to open on temperature increase. TYPE DSW-235-3 suffix -3 indicates circuit is to close on temperature increase. FOR EXPLANATION OF CIRCUIT SUFFIX NUMBERS AND VARIATIONS SEE PAGE 4. (Series D-200 and D-400 available SP-ST only.)

**LOCATION AND MOUNTING OF CONTROL CASE**

Follow equipment manufacturer's instructions or proceed as follows: Vibration causes erratic operation of any instrument and shortens its life. It is important to select a location that is reasonably free of vibration. All controls must be mounted vertical and level.

**GENERAL PURPOSE TYPES—DA, DS, DL, DR**—these controls without flange mounting are mounted by means of a bracket supplied with control. When controls are provided with a flanged case for panel mounting mount by means of holes provided in flanged part of case. See drawing 1000F page 4.

**WEATHER RESISTANT TYPES—DAW, DSW, DRW, DLW**—For surface mounting only. Has flanged case with bottom connection. See drawing 1062 page 4.

**EXPLOSION PROOF TYPES—DAE, DSE, DLE, DRE, DAH, DSH, DRH**—Mount by means of mounting lugs which are a part of the control housing. See drawings 98D and 1350, page 4.

**LOCATION OF REMOTE BULB TO INSURE PROPER CONTROL OPERATION**

- The temperature sensing bulb should be completely immersed in the medium being controlled.
- BULB MUST BE CORRECTLY LOCATED AND PROPERLY INSTALLED** so that the temperature changes at the BULB reflect actual temperature changes of the medium being controlled.
- Be sure that bulb will not be affected by external temperatures.
- If ambient conditions effect Bulb or Well, insulate exposed surfaces.
- Bulb may be installed vertically or horizontally. The following precautions should be taken:
  - Bulb location should not exceed an elevation greater than 6 ft. above or below control case especially on range No. 3 and up. Higher elevation may require compensation in control setting.
  - Do not install bulb in a dead end of a pipe, tank, etc., where it would not be subjected to free circulation of the medium being controlled. (Illustration No. 5).
  - If bulb No. 2 or 2A is located in pipe or duct with diameter larger than the bulb length, the bulb can be installed perpendicularly into the pipe if protected from possible damage due to flow velocity.
  - If bulb 2 or 2A is to be inserted into a pipe with a diameter smaller than the bulb length (example: a 2-7/8" long bulb in a 1" pipe) the bulb should be located longitudinally in the pipe so that the entire length is exposed to the flowing medium. Example: replace an elbow in the pipe with a tee and install bulb as shown in drawing No. 6 and 7. If pipe is 1" in diameter or less, provide an enlarged section around the bulb so that it does not seriously restrict flow.
  - When No. 2 or 2A bulb is to be inserted in a rapidly flowing stream of fluid in a pipe or duct, make sure that it is mechanically protected against the velocity in order to prevent the bulb from breaking off the capillary.

**BULB PROTECTION**

There are three ways to protect bulb No. 2 or 2A:

- Before tightening packing gland, pull bulb back into union as far as possible (standard No. 2 bulb with 3/4" union only). The union is recessed to provide some support.
- Where insertion depth is greater than Bulb length use Extension Sleeve "B" see drawing Nos. 8, 9 and 10.
- Separable well see drawing No. 10. Well slows down heat transfer of temperature changes to the bulb and consequently increases response time of the control. Union will slide back on capillary allowing complete immersion of bulb in any depth of well. For Wells, see below.

**FOR DIMENSIONS OF BULBS SEE CHART—PAGE 3**

Caution.—When installing bulbs with union connections be careful not to twist the flexible tubing. Loosen packing nut or union so that the union can turn freely around tubing. After union is firmly secured to pipe or tank, position bulb by sliding tubing thru union and then tighten the packing gland nut.

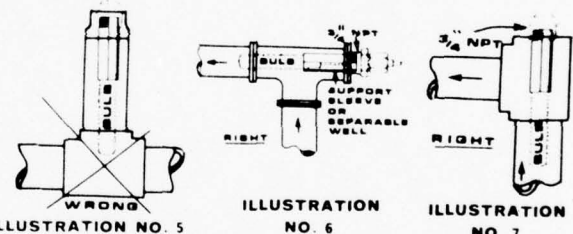

ILLUSTRATION NO. 5

ILLUSTRATION NO. 6

ILLUSTRATION NO. 7

**INCORRECT INSTALLATION**

Note that a very small portion of the bulb is exposed to the direct path of medium being controlled. Section containing bulb has no flow so its temperature is affected by radiation to or from the surrounding air.

**RECOMMENDED INSTALLATION**

These two illustrations indicate the bulb is completely exposed (in direct path) of medium being controlled.

**CROSS AMBIENT TEMPERATURE BULBS**

Cross ambient conditions exist when the temperature surrounding the control case can be either higher or lower  $\pm 10$  F. from the temperature setting for which the control is to operate. Example: Operating point 60°F, control located in an unheated building subject to seasonal temperature changes -10 F. in winter, +95 F. in summer.

To insure proper operation under cross ambient conditions, Bulb Nos. 1A or 2A must be used.

**WHERE TURBULENT OR FAST FLOWING LIQUIDS PREVAIL**

Bulb supports for Bulbs No. 2 and 2A are used where the bulb is mounted in turbulent or fast flowing liquids or where it is desired to insert the remote bulb at some distance within a vessel, pipe, or tank—See "B" illustration Nos. 8, 9 and 10. The remote bulb should be positioned so that at least one inch of the bulb is within the extension sleeve (dim "B") in order to insure firm support. No. 2 and 2A bulb unions are threaded to receive extension sleeves "B". Extension addition "A" permits extending the mounting thru insulation.

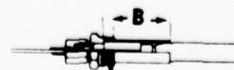

ILLUSTRATION NO. 8



ILLUSTRATION NO. 9

CONTINUED ON PAGE 2

**WELLS**

Wells (dimensions "A" and "C"—see drawing No. 10) are used to protect the remote Bulb from physical damage or to permit removal of the bulb without draining the system.

The use of a well, will of course increase the time lag of the control—the temperature change of the controlled medium must be transmitted through the wall of the well and then to the temperature sensitive bulb of the control. Thus, when wells are used, it is important that the well dimension "C" be equal to, or greater than the bulb length "B" in order to insure that all of the temperature sensitive bulb is within the liquid area.

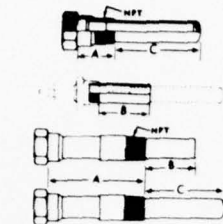

ILLUSTRATION NO. 10

**WIRING**

Wire in accordance with local electrical codes or follow equipment manufacturer's recommendations. On general purpose controls, do not attach rigid conduit to case. Use a short strip of BX to relieve conduit expansion and contraction strains.

Where a control is connected directly into the load circuit, it must be connected into the hot side of line.

Do not overload electrically—see nameplate attached to control for electrical rating.

**ADJUSTMENTS**

How To Set Operating Point Of Control

**DA— DOUBLE ADJUSTMENT TYPES— FULLY AUTOMATIC**

Prefixed by DA, DAE, DAH, DAW— Provided with double adjustments. Adjust the upper pointer to set the "high" temperature point for switch operation. Adjust the lower pointer to set the "low" temperature operating point. The difference between the upper and lower pointers is the operating differential between "on-off" switch operation. Minimum differential for each range is shown on Page 3.

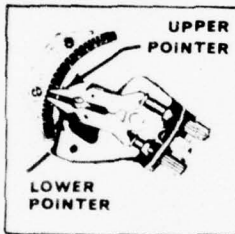

**DS— SINGLE ADJUSTMENT TYPES FULLY AUTOMATIC**

Prefixed by DS, DSE, DSH, DSW— Equipped with a single adjustment. The single pointer on the scale sets the temperature where switch operation occurs. Differential is fixed (not adjustable). For fixed differential of each respective range, see Page 3.

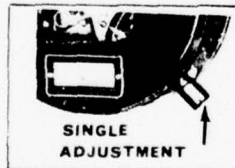

**DL— MANUAL LOCK TYPE RESET CONTROL**

Operates automatically on a decrease of temperature with provision for manual reset when temperature is below set point.

Prefixed by DL, DLH, DLW, DLE—a single adjustment sets the low temperature operating point of control at any value on the scale range.

The control will operate automatically at the set point only on a drop of temperature.

The DL lock type feature permits the circuit to be reset and locked into position, when temperatures are below control setting.

The lock feature remains in effect until the temperature has risen to a value above the control setting. Lock then releases and the circuit is held in the reset position due to the temperature rise. It will remain in the reset position until it is called on to again operate automatically on a temperature drop to the selected setting.

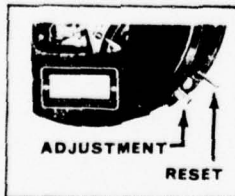

**DR— SEMI-AUTOMATIC CONTROL WITH MANUAL RESET**

Prefixed by DR with suffix -L or -U (example: DR-35-2U). A single adjustment sets the operating point for automatic operation. A push button reset



CONTINUED NEXT COLUMN

must be operated manually to restore the circuit to the original position after automatic operation. Example—Type DR-35-3L: circuit will open automatically on a temperature rise to the temperature indicated by the pointer on the scale—no matter how much the temperature drops the circuit will not reclose until the reset button is operated.

Suffix -L denotes control will operate automatically on an increase. Suffix -U denotes control will operate automatically on a decrease.

**TWO-STAGE TEMPERATURE CONTROL SERIES D-400**

TYPES DA-435, DAW-438, DAH-435, DAE-435—This series incorporates two single pole, single throw magnetic mercury switches, actuated by the same Bourdon Tube. The operating point of each switch is adjustable thru an outside adjustment. The change in temperature which opens and closes each switch at its respective setting is the "fixed differential" (sensitivity) of the switch. The temperature represented by the difference between the two adjustment points is the temperature "spread" between operation of the two switches. Upper pointer indicates the operating point of the "high" temperature circuit. Lower pointer indicates the operating point of the "low" temperature circuit.

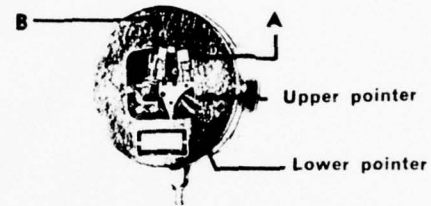

Example Setting: Type DA-435. Specification No. 4122, range 0-75 F. with lower pointer set at 25 F. and upper pointer at 50 F., both circuits will be closed when the temperature is 25 F. and lower. When temperature rises to 25 F. mercury switch "A" will open its circuit. When temperature rises to 50 F. mercury switch "B" will open its circuit, both switches remain open above this setting. The fixed differential (sensitivity) of each switch for this particular range and setting is 2 F. and upon a drop in temperature, mercury switch "B" will close its circuit at 48 F. and mercury switch "A" will close its circuit at 23 F.

**SERIES D-400 RANGES AND DIFFERENTIALS**

Range No.	Adjustable Working Range F.	Maximum Temperature Must Not Exceed	Minimum Temperature Spread Between Switch Operation			Fixed Differential Each Switch (Sensitivity)		
			Low	Med	High	Low	Med	High
1A	-60 +30	120°	30	15	8	8	4	2
1	-30 +60	120°	18	10	5	4	2	1
2	0-75	120°	12	7	4	3	2	1
3	25-100	120°	9	6½	3½	2	1½	¾
4	50-150	170°	20	12	7	4	2	1
5	100-200	220°	15	8½	7	2½	1½	¾
6	140-250	260°	15	9	5	2	1½	1
7	150-270	285°	17	10	5½	2½	1½	1
7A	200-300	320°	12	8	4½	3	1¾	1
8	250-380	400°	18	10	5½	3½	1½	1
8A	280-415	440°	20	9	6	3	1½	1
9	370-530	550	24	12	7	4	2	1

**SERIES D-400**

**SWITCH OPERATING SPECIFICATIONS**

In ordering, select operation desired, add suffix number of specification to the type number of control. EXAMPLE: Type DA 435 4122

Specification No.	Switch Mk.	CONTACT POSITION		
		Low	Inter-mediate	High
-4122	"A"	ON	OFF	OFF
	"B"	ON	ON	OFF
-4129	"A"	OFF	ON	ON
	"B"	OFF	OFF	ON
-4132	"A"	ON	OFF	OFF
	"B"	OFF	OFF	ON
-4123	"A"	OFF	ON	ON
	"B"	ON	ON	OFF

SPECIFICATION NO. 4122. One circuit opens on increase of temperature—second circuit opens on further increase of temperature.

SPECIFICATION NO. 4129. One circuit closes on increase of temperature—second circuit closes on further increase of temperature.







SPECIFICATION NO. 4132. Both circuits open at intermediate temperature. One circuit closes on increase of temperature above neutral zone—second circuit closes on decrease in temperature below neutral zone.

SPECIFICATION NO. 4123. Both circuits close at intermediate temperature. One circuit opens on increase of temperature above neutral zone—second circuit opens on decrease in temperature below neutral zone.

## OPERATING RANGES—DIFFERENTIALS

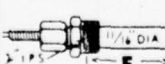
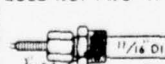
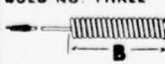
Differentials shown pertain to SP-ST controls only. When controls incorporate two mercury switches for double throw or two pole operation, the differentials are approximately double those of standard single pole circuits.			DOUBLE ADJUSTMENT Types DA-35, DAW-35, DAH-35, DAE-35			DOUBLE ADJUSTMENT Types DA-535, DAW-535, DAH-535, DAE-535			SINGLE ADJUSTMENT Types DS-235, DS-235, DBH-235, DBE-235		
			MINIMUM DIFFERENTIAL WHEN OPERATING POINT IS SET AT			MINIMUM DIFFERENTIAL WHEN OPERATING POINT IS SET AT			FIXED DIFFERENTIAL WHEN OPERATING POINT IS SET AT		
ADJUSTABLE OPERATING RANGE °F	RANGE NO.	MAXIMUM TEMPERATURE MUST NOT EXCEED	HIGH °F	MED. °F	LOW °F	HIGH °F	MED. °F	LOW °F	HIGH °F	MED. °F	LOW °F
-60 + 30°	1A	120°F.	5°	10°	15°	3°	6°	12°	1.5°	2.5°	3.0°
-30 + 60°	1	120°F.	3°	5°	12°	2°	4°	8°	0.7°	1.5°	1.0°
0-75°	2	120°F.	1.5°	4°	8°	1.5°	3°	5°	0.6°	1.0°	1.5°
0-75°	2A	240°F.	1.5°	4°	8°						
25-100°	3	120°F.	1°	3°	5°	1.0°	2°	3°	0.6°	1.0°	1.5°
50-150°	4	170°F.	2°	6°	12°	2°	4°	7°	0.7°	0.9°	1.5°
100-200°	5	220°F.	2°	5.5°	9°	1°	2°	3°	0.8°	1.5°	3.0°
*140-250°	6	260°F.	3°	6°	10°	1°	2°	3°	0.8°	1.5°	3.0°
150-270°	7	285°F.	3°	5°	12°	1°	2°	3°	0.8°	1.5°	3.0°
200-300°	7A	320°F.	3°	6°	10°	1.5°	3°	6°	0.8°	1.5°	3.0°
250-380°	8	400°F.	3°	6°	12°	1°	2°	3°	0.8°	1.5°	2.0°
280-415°	8A	440°F.	5°	8°	8°	3°	6°	9°	1.5°	3.0°	5.0°
370-530°	9	550°F.	4°	8°	14°	2°	3°	4°	1.0°	1.5°	3.0°

## BULB SPECIFICATIONS

BULB NUMBERS <small>B" - BULB LENGTH E" - MIN. INSERTION DEPTH</small>	APPLICATION	MATERIAL Bulb and 6 Ft. Tubing	RANGE NUMBERS					
			RANGE 1,1A,2	RANGE 2A	RANGE 3	RANGE 4	RANGE 5,6,7,7A,8	RANGE 8A, 9
<b>BULB NO. ONE</b> 	For liquid or gases not under pressure	COPPER	B = 4-7/8"	B = 4-7/8"	NOT AVAILABLE		B = 3"	NOT AVAILABLE
		STAINLESS STEEL	B = 5-1/4"	B = 5-1/4"	NOT AVAILABLE		B = 5-1/4"	B = 5-1/4"
<b>BULB NO. ONE "A"</b> 	For liquid or gases not under pressure Where cross ambient conditions exist see note 1.)	COPPER	B = 13"	NOT AVAILABLE	B = 13"	B = 13"	B = 13"	NOT AVAILABLE
		STAINLESS STEEL	B = 16"	NOT AVAILABLE	B = 16"	B = 16"	B = 16"	B = 16"
<b>BULB NO. TWO</b> 	For liquids or gases under pressure (max. 300 lbs.) For pressure above 300 lbs. see note 1.)	COPPER	E = 4-1/4"	E = 4-1/4"	NOT AVAILABLE		E = 2-7/8"	NOT AVAILABLE
		STAINLESS STEEL	E = 4-7/8"	E = 4-7/8"	NOT AVAILABLE		E = 4-7/8"	E = 4-7/8"
<b>BULB NO. TWO "A"</b> 	For liquids or gases under pressure (max. 300 lbs.) Where cross ambient conditions exist see note 1.)	COPPER	E = 12-3/8"	NOT AVAILABLE	E = 12-3/8"	E = 12-3/8"	E = 12-3/8"	NOT AVAILABLE
		STAINLESS STEEL	E = 15-5/8"	NOT AVAILABLE	E = 15-5/8"	E = 15-5/8"	E = 15-5/8"	E = 15-5/8"
<b>BULB NO. THREE</b> 	For air or gases (coil type 1.8 in. O.D. x 6 in.)	COPPER	B = 7"	NOT AVAILABLE	NOT AVAILABLE	NOT AVAILABLE	B = 7"	NOT AVAILABLE
<b>BULB NO. FOUR</b> 	Same as Bulb No. 3 except with 1/2 in. IPS connection	COPPER	E = 10"	NOT AVAILABLE	NOT AVAILABLE	NOT AVAILABLE	E = 10"	NOT AVAILABLE
<b>BULB NO. FIVE</b> 	For air, gases or surface mounting (10 ft. uncoiled 3/16 in. O.D. tubing)	COPPER	NOT AVAILABLE	NOT AVAILABLE	NOT AVAILABLE	NOT AVAILABLE	10 FT. UNCOILED TUBING 3/16" O.D.	NOT AVAILABLE
<b>BULB NO. SIX</b> 	For surface mounting flat coil with mounting bracket	COPPER	NOT AVAILABLE	NOT AVAILABLE	NOT AVAILABLE	NOT AVAILABLE	FLAT COIL WITH MOUNTING BRACKET	NOT AVAILABLE

3) Bulbs 1A and 2A must be used where cross-ambient conditions occur. Example - where temperature surrounding the control case can vary both above and below temperature at the remote bulb.

4) For pressures to 4,000 psi use BULB NO. 21 with Packing Gland Assembly. Available with 1/8" diameter bulb and 1/2" male IPS union. Available only for Ranges 5 to 9 inclusive (write for details).

**EXPLANATION OF CIRCUIT SUFFIX NUMBERS**

Suffix No.	CIRCUIT	Circuit Response to Pressure Increase
-2	SP-ST	Opens
-3	SP-ST	Closes
-4	DP-ST	Closes
-5	3 Pole, ST	Closes
-26	SP-ST	Closes
-36	SP-ST	Opens
-54	DP-ST	Opens
-55	3 Pole, ST	Opens
-103	DP-ST	Closes
-113	DP-ST	Closes
-127	DP-ST	Opens
-152	SP-DT	One Closes as Other Opens
-153	SP-DT	One Closes as Other Opens
-154	2 CIRCUITS 1 CIRCUIT	CLOSE OPENS
-155	1 CIRCUIT 2 CIRCUITS	CLOSES OPEN
-156	SP-DT	One Closes as Other Opens
-160	ALARM SP-ST	CLOSES 9-61 OPENS 9-51
-705	SP-DT SP-ST	One Opens as Other Closes CLOSES
-729	SP-DT ST-ST	One Closes as Other Opens OPENS
-804	DP-DT	TWO CLOSE TWO OPEN
-815	4 Pole, ST	Close
-816	4 Pole, ST	Open

**LOCKING DEVICE**

When the control has been adjusted to desired range, the locking bar may be inserted between the adjustment screws with slot passing over the projecting lug. By placing a sealing wire between the locking bar and the hole in the lug protruding from adjustment assembly, adjustments cannot be tampered with.

For DAW, DXAH, DSH, DXSH, sealing wire may pass through locking bar and hole in hub above adjusting knobs.

DAW, DRW, DSW, adjusting knob cover may be sealed in place with sealing wire through cover bolt hole.

**DIMENSIONS**

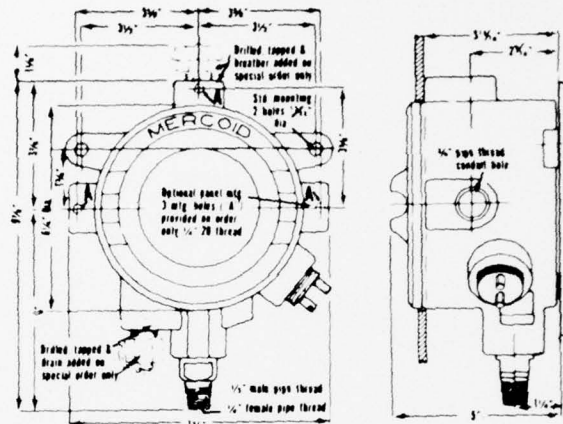

**EXPLOSION PROOF**  
Prefixed by  
DAH, DLH, DRH, DSH,  
DXLH, DXRH, DXSH

Drawing No. 1350

**WEATHER RESISTANT**  
Prefixed by  
DAW, DRW, DSW,  
DXAW, DXLW, DXRW, DXSW

Drawing No. 1062

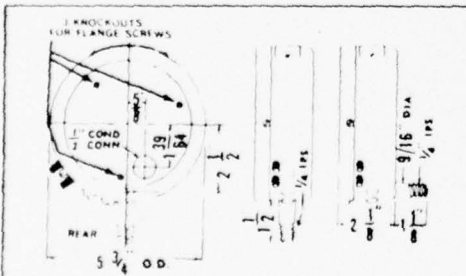

PLAIN CASE - BOTTOM CONNECTION - BACK CONNECTION  
**GENERAL PURPOSE**  
Prefixed by  
DA, DL, DR,  
DS, DXA, DXL, DXR, DXS

Drawing No. 1000B

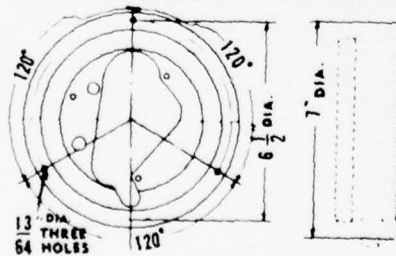

**FLANGE FOR SURFACE MOUNTING**  
FOR GENERAL PURPOSE CONTROLS

Drawing No. 1000F

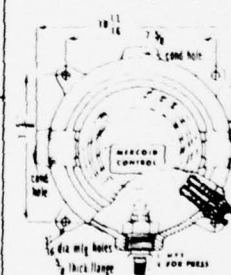
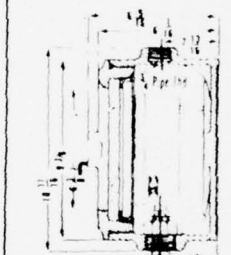

**EXPLOSION PROOF**  
Prefixed by  
DAE, DLE, DRE, DSE,  
DXLE, DXRE, DXSE

Drawing No. 98D



THE MERCROID CORPORATION, 4201 BELMONT AVE., CHICAGO, ILL. 60641

"MERCROID" UNITED STATES OF AMERICA-CANADA-MARCA REGISTRADA ARGENTINA CHILE  
HONDURAS MEXICO PERU URUGUAY & VENEZUELA - MARCHIO REGISTRATO ITALY-MARQUE DEPOSEE FRANCE



### INSTALLATION INSTRUCTIONS

Bulletin No.

0-0118R

## MERCID SERIES "D" PRESSURE CONTROLS

WITH HERMETICALLY SEALED MERCURY SWITCHES & BOURDON TUBE POWER ELEMENTS

(The following instructions apply to Mercoid Pressure Controls prefixed by the letter "D" except Series "DP" Differential Pressure Controls.)



GENERAL PURPOSE Prefixed by DA, DAF, DL, DR, DS, DRF, DSF

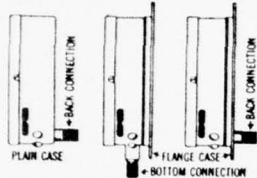

WATERTIGHT OR WEATHER-RESISTANT Prefixed by DAW, DRW, DSW, N3-DAW, N3-DRW, N3-DSW



EXPLOSION PROOF Prefixed by DAH, DAHF, DLH, DRH, DSH



EXPLOSION PROOF Prefixed by DAE, DLE, DRE, DSE

### CONTROL NUMBERS

Part of the control number identifies the type of control case. The digit 1 of 21, 31, 41, 51, 61, 81, 221, 231, 241, 251, 261, 281, 421, 431, 441, 451, 461, 521, 531, 541, 551, 561, 581, denotes a plain case with bottom connection.

The digit 2 of 22, 32, 52, 62, 222, 232, 242, 252, 262, 422, 432, 452, 462, 522, 532, 562, denotes a plain case with back connection.

The digit 3 of 23, 33, 43, 53, 63, 83, 223, 233, 243, 253, 263, 283, 423, 433, 443, 453, 463, 523, 533, 543, 553, 563, 583, denotes a flanged case with bottom connection.

The digit 4 of 24, 34, 54, 64, 224, 234, 254, 264, 524, 554, denotes a flanged case with back connection.

### CIRCUIT SUFFIX NUMBERS (SWITCH OPERATION)

Suffix number after control number denotes whether circuit is to open or close on increase or decrease of pressure, etc. Examples: TYPE DA-21-2 -suffix -2 indicates circuit is to open on pressure increase. Type DSW-221-3 -suffix -3 indicates circuit is to close on pressure increase. FOR EXPLANATION OF CIRCUIT NUMBERS AND VARIATIONS SEE PAGE 4.

### LOCATION AND MOUNTING

Select a location recommended by equipment manufacturer. Note: Vibration causes erratic operation of any instrument and shortens its life. It is important that a location be selected that is reasonably free from vibration caused by reciprocating or rotating machinery. Where excessive vibration occurs, use a remote connection and mount by means of a mounting bracket or separable flange (available on order). Where pulsations, pressure surges or water hammer are present, protect the control with a surge tank or snubber.

### MOUNT ALL CONTROLS VERTICALLY AND LEVEL

GENERAL PURPOSE CONTROLS: Prefixed by letters DA, DAF, DRF, DL, DS, DSF. Install control firmly in a LEVEL POSITION. Do not mount control by twisting the case, use wrench on the square part of the 1/4" bottom pipe connection. To level, sight across the two cover screws or check the lower end of the glass opening in cover to see that the control is lined up horizontally. (On controls with an operating range of 500-5,000 psi, be sure that the special sealing nut (with Teflon insert) is turned to the uppermost threaded section of the 1/2" pressure connection. Apply a flat open-end wrench to the flat side of the bottom pressure connection when piping the control. After it has been properly connected, be sure to tighten the sealing nut in order to assure a leak-proof connection). On general purpose controls provided with a flange, mount by means of the three holes in flange - see drawing No. 1000B page 4.

WATERTIGHT OR WEATHER RESISTANT TYPES: Prefixed by letters DAW, DRW, DSW, DLW, N3-DAW, N3-DRW, N3-DSW, N3-DLW: Supplied with flanged case, bottom connection only, for surface mounting. (see drawing No. 1062, page 4) Install firmly in a LEVEL POSITION. Do not mount control by twisting the case, use wrench on the square part of the 1/4" bottom pipe connection. Be sure pipe connection is in a vertical position. After cover is properly attached with name plate on bottom of cover, sight across the lower end of the glass opening in cover to see that control is lined up vertically.

EXPLOSION PROOF TYPES: Prefixed by letters DAH, DAHF, DRH, DSH, DAE, DRE, DSE: (see drawings No. 1350 and 1062, page 4) Mount control level by means of mounting lugs attached to control housing. Line up horizontally by sighting across the left and right conduit hubs.

WHEN IN DOUBT AS TO EXCESSIVE VIBRATION USE A REMOTE CONNECTION.

### NOTE:

SERIES D-30, D-230, D-430, D-530 (i.e., DA-31-3, etc.) when used for steam with operating ranges 35 psi or higher, must be siphoned to prevent live steam entering the Bourdon tube. On high pressure steam in excess of 100 psi, use a remote connection (see illustration, page 1).

SERIES D-20, D-220, D-420, D-520 (i.e., DA-21-2, etc.) incorporate an orifice as standard in the bottom stem to dampen out surges or pulsations.

### ACCESSORIES



Remote Connection No. 49-62 (300 psi. No. 49-62HP (to 2500 psi.))

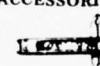

MOUNTING BRACKET No. 33-25



Pigtail Siphon No. 42-51 (300 psi.) No. 42-56-57 (2,000 psi.)

### WIRING

Wire in accordance with local electrical codes or equipment manufacturer's instructions.

For general purpose controls use a short piece of BX between the rigid conduit and the control so that it will not be subjected to conduit expansion and contraction. Where control is directly connected into load circuit it should be connected into hot side of line. For electrical rating see nameplate attached to control case.

## ADJUSTMENTS HOW TO SET OPERATING POINT

### DOUBLE ADJUSTMENT TYPES-FULLY AUTOMATIC:

Prefixed by DA, DAF, DAE, DAW, DAH, DAHF - provided with double adjustments. Adjust the upper pointer "C" to set the HIGH PRESSURE POINT for switch operation. Adjust the lower pointer "U" to set the LOW PRESSURE OPERATING POINT. The difference between the HIGH and LOW pointers is the operating differential between "on-off" switch operation. Minimum differential for each respective range is shown on page 3.



### SINGLE ADJUSTMENT TYPES-FULLY AUTOMATIC:

Prefixed by DS, DSE, DSF, DSH - equipped with a single adjustment. The single pointer on the scale sets the pressure where switch operation occurs. Differential is fixed (not adjustable). Example setting: Type DS-21-2 range 0-60 psi, circuit opens on pressure rise. If pointer is set at 40 psi., the control will operate to OPEN circuit at 40 psi and RE-CLOSE CIRCUIT AT THE FIXED DIFFERENTIAL OF 4 PSI. For fixed differential of each range see page 3.



Single Adjustment

(Continued on page two)

## ADJUSTMENTS (CONTINUED)

### SEMI-AUTOMATIC CONTROL WITH MANUAL RESET

Prefixed by DR, DRF, DRH, DRE, DRW-with suffix -L or -U. Example: DR-21-2U. A single adjustment sets the operating point for automatic operation. A push button reset must be operated manually to restore the circuit to the original position after automatic operation. Example: Type DA-21-2L - circuit will open automatically on a pressure rise to the pressure indicated by the pointer on the scale - no matter how much the pressure drops, the circuit will not reclose until the reset button is operated.



Suffix -L denotes control will operate automatically on an increase. Suffix -U denotes control will operate automatically on a decrease.

### MANUAL LOCK TYPE RESET CONTROL

Operates automatically on a decrease of pressure with provision for manual reset when pressure is below set point.

Prefixed by DL, DLW, DLE, DLH: a single adjustment sets the low pressure operating point of control at any value on scale range.

The control will operate automatically at the set point only on a drop of pressure. The lock type feature permits the circuit to be reset and locked in position when pressures are below control setting.

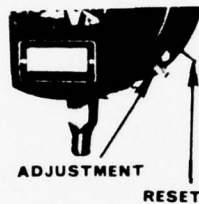

The lock remains in effect until the pressure has risen to a value above the control setting. Lock then releases and the circuit is held in the reset position due to the pressure rise. It will remain in the reset position until it is called on to again operate automatically on a pressure drop to the selected setting.

## TWO-STAGE PRESSURE CONTROLS SERIES D-400

Types DA, DAW, DAH, DAE - with suffixes 421, 423, 431, 433, 451, 453, 461, 463, etc. Followed by specification numbers 4122, 4123, 4129, 4132.

This series incorporates two single pole, single throw, magnetic mercury switches, actuated by the same Bourdon tube. The operating point of each switch is adjustable thru an outside adjustment.

The change in pressure which opens and closes each switch at its respective setting is the fixed differential of the switch. The pressure represented by the difference between the two adjustment pointers is the pressure "spread" between operation of the two switches (see illustration).

Upper pointer "U" indicates the operating point of the HIGH pressure circuit. Lower pointer "L" indicates the operating point of the LOW pressure circuit. See switch operating specification chart on this page.

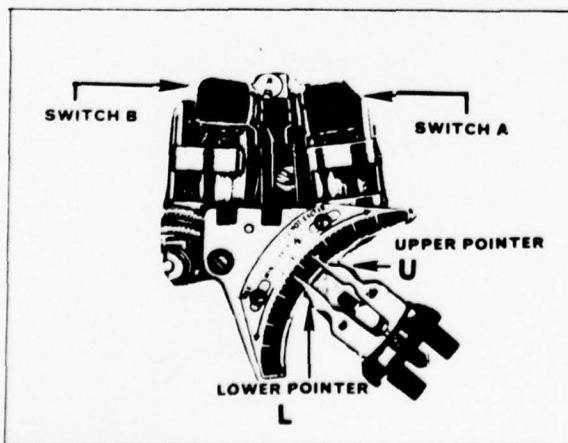

2

## TWO STAGE OPERATION (CONTINUED)

EXAMPLE SETTING: - Type DA-421, Specification No. 4122, range 0-60 psi. With lower pointer "L" set at 25 psi, and upper pointer "U" at 50 psi., both circuits will be closed when the pressure is 25 psi and lower. When pressure rises to 26 psi, mercury switch "A" will open its circuit. When pressure rises to 50 psi, mercury switch "B" will open its circuit; both switches remain open above this setting. The fixed differential (sensitivity) of each switch for this particular range is 1 psi and upon a drop in pressure, mercury switch "B" will close its circuit at 49 psi and mercury switch "A" will close its circuit at 25 psi.

## TWO-STAGE PRESSURE CONTROLS SERIES D-400 RANGES AND DIFFERENTIALS

Range No.	Adj. Working Range	Maximum Momentary Surge	Bourdon Tube Material	Minimum Pressure Spread Between Switch Operation	Fixed Differential Each Switch (Sensitivity)
For Steam and Other Applications: DA-431, DAW-433, DAH-431, DAE-431					
2	0-30" Vac.	30#	Brass	4" Hg.	1" Hg. Vac.
3	10" Vac. 12#	30#	Brass	2 1/2 psi	1/2 psi
3A	1/8-20#	30#	Brass	2 1/2 psi	1/2 psi
4	1-35#	50#	Brass	3 1/2 psi	1/2 psi
5	2-60#	80#	Brass	5 psi	1/2 psi
6	5-100#	125#	Brass	7 psi	1 psi
7	5-150#	200#	Brass	10% psi	1 1/2 psi
8	5-200#	240#	Brass	15 psi	1 1/2 psi
9	10-300#	400#	Brass	25 psi	2 psi
27	25" Vac. 50#	125#	Brass	7 psi	1 psi
For General Pressure Applications: DA-421, DAW-423, DAH-421, DAE-421					
28S	10" Vac. 75#	200#	Steel	7 psi	1 1/2 psi
5S	2-60#	120#	Steel	6 psi	1 1/2 psi
6S	5-100#	300#	Steel	8 psi	2 psi
7S	5-150#	300#	Steel	10 psi	2 psi
8S	10-200#	300#	Steel	10 psi	2 psi
9S	10-300#	500#	Steel	20 psi	4 psi
10S	25-600#	800#	Steel	40 psi	7 psi
11S	50-1000#	1500#	Steel	100 psi	10 psi
12S	100-1500#	2000#	Steel	150 psi	12 psi
13S	300-2500#	3000#	Steel	250 psi	20 psi
15S	500-5000#	7000#	Steel	600	150
26S	30" Vac. 75#	300#	Steel	10 psi	2 psi

SPECIFICATION NO. 4122. One circuit opens on increase of pressure—second circuit opens on further increase of pressure.

SPECIFICATION NO. 4129. One circuit closes on increase of pressure—second circuit closes on further increase of pressure.

SPECIFICATION NO. 4132. Both circuits open at intermediate pressure. One circuit closes on increase of pressure above neutral zone—second circuit closes on decrease in pressure below neutral zone.

SPECIFICATION NO. 4123. Both circuits close at intermediate pressure. One circuit opens on increase of pressure above neutral zone—second circuit opens on decrease in pressure below neutral zone.

### SWITCH OPERATING SPECIFICATIONS

In ordering, select operation desired, add suffix number of specification to the type number of control. EXAMPLE: Type DA 431 4122

Specification No.	Switch Mk.	CONTACT POSITION		
		Low Pressure Hi-Vac.	Inter-mediate Pressure	High Pressure Lo Vac.
-4122	"A"	ON	OFF	OFF
	"B"	ON	ON	OFF
-4129	"A"	OFF	ON	ON
	"B"	OFF	OFF	ON
-4132	"A"	ON	OFF	OFF
	"B"	OFF	OFF	ON
-4123	"A"	OFF	ON	ON
	"B"	ON	ON	OFF

5-74T1  
PRINTED IN U.S.A.

A3-7

# PRESSURE CHART FOR SERIES "D" MERCOID PRESSURE CONTROLS

## OPERATING RANGES—ADJUSTMENT—DIFFERENTIALS—ELECTRICAL RATINGS

CONTROLS WITH BOURDON TUBE POWER ELEMENTS AND MERCURY SWITCH CONTACTS

CONTROLS WITH MERCURY SWITCHES -2 (SP-ST) OPENS on increase -3 (SP-ST) CLOSES on increase -153 (SP-DT) One opens as other closes			ADJUSTABLE DIFFERENTIAL DOUBLE ADJUSTMENT for setting both "on" and "off" operating points. Maximum differential—full scale. Minimum differential listed below.		FIXED DIFFERENTIAL SINGLE ADJUSTMENT Adjustable operating point. Differential fixed NOT ADJUSTABLE
APPLICATION Bourdon tube material	ADJUSTABLE OPERATING RANGE PSIG	RANGE NO.	SEE CODE A	SEE CODE B	SEE CODE C
			DA-31	DA-531	DS-231
FOR GASES, STEAM OR LIQUIDS NOT INJURIOUS TO BRASS BOURDON TUBES	0-30" Hg. Vac.	2	2" Hg.	1" Hg.	0.2" Hg.
	10" Hg. Vac. 12	3	1 PSIG	0.5 PSIG	2 oz.
	1/8-15 PSIG	1	1 PSIG	0.5 PSIG	2 oz.
	1/8-20 PSIG	3A	1 PSIG	0.5 PSIG	2 oz.
	1-35 PSIG	4	1.75 PSIG	0.75 PSIG	4 oz.
	25" Hg. Vac. 50	27	3.5 PSIG	2 PSIG	7 oz.
	2-60 PSIG	5	3 PSIG	1 PSIG	6 oz.
	5-100 PSIG	6	3.75 PSIG	2 PSIG	7 oz.
	5-150 PSIG	7	6 PSIG	3 PSIG	8 oz.
FOR GASES OR LIQUIDS NOT INJURIOUS TO 403 STAINLESS STEEL BOURDON TUBES	10-200 PSIG	8	8 PSIG	3.5 PSIG	12 oz.
	10-300 PSIG	9	12 PSIG	6 PSIG	16 oz.
			<b>DA-21</b>	<b>DA-521</b>	<b>DS-221</b>
	30" Hg. Vac. 60	25S	6 PSIG	3 PSIG	12 oz.
	30" Hg. Vac. 75	26S	8 PSIG	4 PSIG	12 oz.
	2-60 PSIG	5S	4 PSIG	2.5 PSIG	0.5 PSIG
	5-100 PSIG	6S	6 PSIG	3 PSIG	0.75 PSIG
	10-200 PSIG	8S	8 PSIG	4 PSIG	0.75 PSIG
	10-300 PSIG	9S	14 PSIG	7 PSIG	1 PSIG
	40-350 PSIG	9AS	14 PSIG	7 PSIG	1 PSIG
	25-600 PSIG	10S	25 PSIG	15 PSIG	2.5 PSIG
FOR MEDIUMS NOT INJURIOUS TO 316 STAINLESS STEEL BOURDON TUBES	50-1000 PSIG	11S	60 PSIG	40 PSIG	10 PSIG
	100-1500 PSIG	12S	90 PSIG	50 PSIG	12 PSIG
	300-2500 PSIG	13S	150 PSIG	100 PSIG	15 PSIG
	500-5000 PSIG	15S	450 PSIG	200 PSIG	150 PSIG
			<b>DA-41</b>	<b>DA-541</b>	<b>DS-241</b>
	5-75 PSIG	23E	3 PSIG	2 PSIG	0.4 PSIG
	10-150 PSIG	24E	6 PSIG	3 PSIG	0.75 PSIG
	10-300 PSIG	9E	18 PSIG	5 PSIG	3 PSIG
30-400 PSIG	21E	30 PSIG	15 PSIG	5 PSIG	
75-800 PSIG	22E	75 PSIG	35 PSIG	12 PSIG	
100-1000 PSIG	11E	100 PSIG	45 PSIG	18 PSIG	
200-2500 PSIG	13E	210 PSIG	110 PSIG	50 PSIG	

### ELECTRICAL RATINGS

CIRCUIT SUFFIX NOS.  
-2 SP-ST OPENS ON INCREASE  
-3 SP-ST CLOSES ON INCREASE  
-153 SP-DT ONE OPENS AS OTHER CLOSES

CODE	CIRCUIT SUFFIX	AC CAPACITY			DC CAPACITY		HORSEPOWER	
		120V.	240V.	440V.	120V.	240V.	AC	DC
A	-2, -3 -153	10A. 4A.	5A. 2A.	3A. ①	10A. 4A.	5A. 2A.	3/4	1/3 NA
B	-2, -3	5A.	2A	NA	2½A.	1A.	1/8	1/10
C	-2, -3	0.3A.	0.15A.	NA	0.15A.	0.07A.	NA	NA

NOTE: Differentials listed above are for SP-ST operation only. When controls incorporate two mercury switches for double throw or two pole operation, the differentials are approximately double those shown for standard single pole, single throw controls.  
FOR MULTIPLE CIRCUITS SEE PAGE 4.

Suffix No.	CIRCUIT	Circuit Response to Pressure Increase
-2	SP-ST	Opens
-3	SP-ST	Closes
-4	DP-ST	Closes
-5	3 Pole, ST	Closes
-26	SP-ST	Closes
-36	SP-ST	Opens
-54	DP-ST	Opens
-55	3 Pole, ST	Opens
-103	DP-ST	Closes
-113	DP-ST	Closes
-127	DP-ST	Opens
-152	SP-DT	One Closes as Other Opens
-153	SP-DT	One Closes as Other Opens
-154	2 CIRCUITS 1 CIRCUIT	CLOSE OPENS
-155	1 CIRCUIT 2 CIRCUITS	CLOSES OPEN
-156	SP-DT	One Closes as Other Opens
-160	ALARM SP-ST	CLOSES 9-61 OPENS 9-51
-705	SP-DT SP-ST	One Opens as Other Closes CLOSES
-729	SP-DT ST-ST	One Closes as Other Opens OPENS
-804	DP-DT	TWO CLOSE TWO OPEN

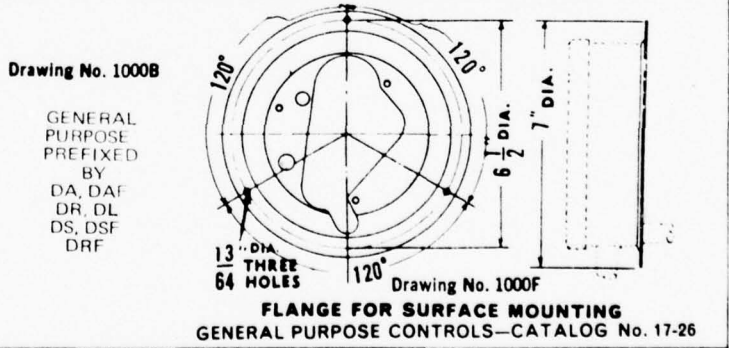
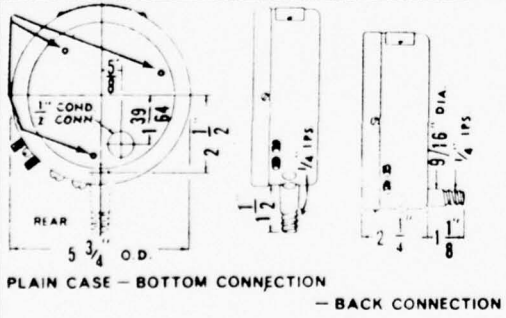
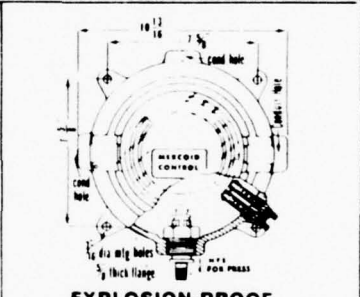
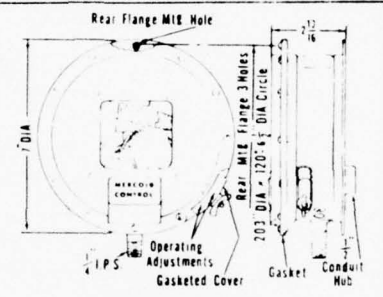
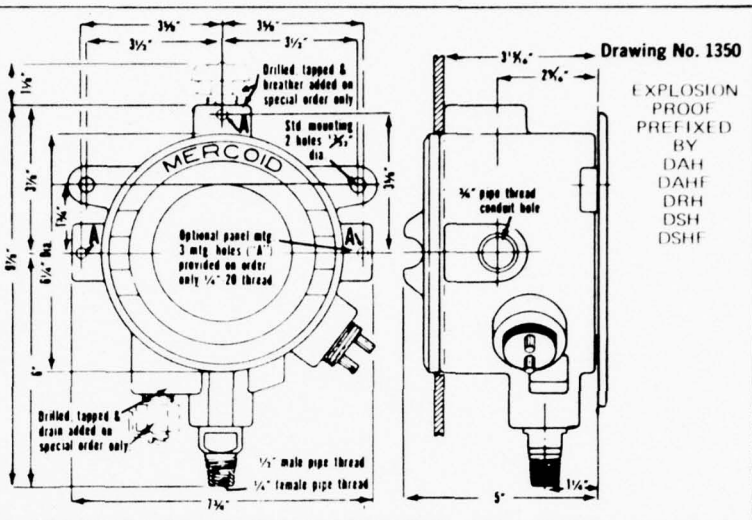

**LOCKING DEVICE**

When the control has been adjusted to desired range, the locking bar may be inserted between the adjustment screws with slot passing over the projecting lug. By placing a sealing wire between the locking bar and the hole in the lug protruding from adjustment assembly, adjustments cannot be tampered with.

For DAF, DRF, DSF, DAW, DRW, DSW, adjusting knob cover may be sealed in place with sealing wire through cover bolt hole. For DAH, DSH, sealing wire may pass through locking bar and hole in hub above adjusting knobs.

**CAUTIONS**

When testing a boiler or system, never exceed maximum pressure rating on control or it may be seriously damaged. Remove control if higher pressures are required.

Do not fail to use a siphon on steam where range is 35lbs. or more. Control movement must not be oiled.

Do not overload - note electrical rating on nameplate and be sure total current passing through switch is within specified rating.

**MERCROID CONTROL**

**THE MERCROID CORPORATION, 4201 BELMONT AVE., CHICAGO, ILL. 60641**

628 Davisville Road, Willow Grove, Penna. 19090  
315 Montgomery Street, San Francisco, California 94104

MERCROID® Reg. Trade Mark (Marca Registrada, Mercoid Deposee, Marca Registrada, Marchio Registrato, Registrert Varemärke, Eingetragenes Warenzeichen) United States of America, Great Britain, Canada, Argentina, Chile, Honduras, Mexico, Peru, Uruguay, Brazil, Venezuela, France, Italy, Spain, Sweden, Denmark, Norway, Belgium, Holland, West Germany.

**SERIES  
301**

**MERCOD LIQUID LEVEL CONTROLS WITH SEALED MERCURY SWITCHES  
MERCONTROL LIQUID LEVEL CONTROLS WITH SNAP-ACTION SWITCHES**

**BULLETIN  
NO. 0-420A**

**FOR PRESSURIZED OR NON-PRESSURED TANKS OR SUMPS**

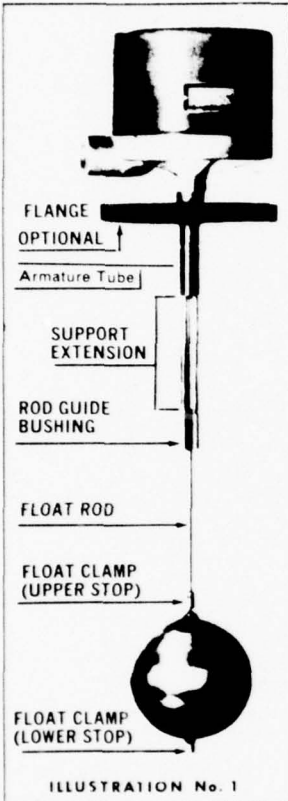

ILLUSTRATION No. 1

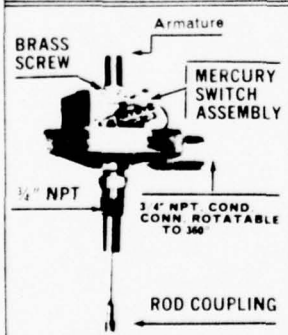

ILLUSTRATION No. 2

**MATERIALS OF  
CONSTRUCTION**

FLOATS—304SS or copper;  
FLOAT ROD—303SS or 316SS;  
FLOAT STOPS—Brass or 304SS;  
SUPPORT EXTENSION—Steel  
galvanized or 304SS;  
ROD GUIDE—303SS with Teflon  
bushing;  
Armature Tube—304SS;  
Armature—430SS.

**OPERATING CHARACTERISTICS**

A float is fixed by means of rod clamps (stops) above and below the float on a float rod connected to a magnetic armature at its upper end. The armature is moved up and down inside a tube within a switch enclosure. One or two switch operating assemblies are mounted on the armature tube. As the float is raised or lowered by liquid level changes, the armature is moved into or withdrawn from the field of the switch magnet, resulting in operation of the switch assembly or assemblies to open or close their respective switches. Float should not move up and down on the float rod—it should be in a fixed position on the rod. Float position on rod determines switch operation.

**EXPLANATION OF TYPE AND CODE  
NUMBERS**

Example: Type 301C-4820  
301 is the type number; letter "C" identifies type of enclosure 4820; designates circuit.

**ENCLOSURES**

**GENERAL PURPOSE** enclosures are identified by the letter "G" in type number as in 301G.

**WEATHER RESISTANT** enclosures are identified by the letter "W" in type number as in 301W.

**EXPLOSION PROOF** enclosures are identified by the letter "E" in type number as in 301E.

**VAPOR PROOF—EXPLOSION PROOF** enclosures are identified by the letters "EV" in type number as in 301EV.

**SPECIAL FEATURES**

**SEMI-AUTOMATIC** (with manual reset) operates automatically on level fall only—manual reset required on level rise. This operation identified by the letters "RU" in type number as in 301GRU, 301ERU.

**WIDE DIFFERENTIAL** (single stage only) available only for controls with mercury switch contacts. Provides approximately double the fixed level change ("D" in Liquid Level Change Table) between on and off switch operation. Identified by the letter "D" in type number as in 301GD.

**440 VOLT SERVICE** for controls with mercury switch contacts only. Identified by the digit 5 in circuit specification number such as in 5820, 5821. On two stage operation, 440V. is limited to SP-ST in each stage.

**LOCATION AND MOUNTING**

All controls must be mounted vertically with switch mechanism in a level position. All piping including flange if used, must be installed to provide level control mounting.

When a flange is not required, the control may be installed by using a 3/4" tapping, provided a hand hole or suitable opening is available for installing the float.

**FLOATS—(PRESSURE AND  
TEMPERATURE RATINGS)**

4-1/2" Copper	150 PSI @ 300° F. MAX.	(NO. 45-43-1)
4-1/2" 304 S.S.	300 PSI @ 500° F. MAX. 800 PSI @ 100° F. MAX.	(NO. 45-30)
3-1/2 x 6" S.S.	300 PSI @ 500° F. 450 PSI @ 100° F.	(NO. 45-80)
7" Copper	150 PSI @ 300° F. MAX.	(NO. 45-49)
7" 304 S.S.	450 PSI @ 100° F. MAX. 425 PSI @ 200° F. MAX. 300 PSI @ 500° F. MAX.	(NO. 45-50)

MAX. TEMP. INSIDE CONTROL 250° F.

ASA FLANGES	FLOAT	SIZE	STEAM		COLD NON-SHOCK	
			125#	200#	175#	400#
	4-1/2"	5" CI	125#	200#	175#	400#
		5" CI	300#	300#	600#	600#
	7"	Same as above for 8" flange.				

**WHERE TURBULENCE OR FAST FLOWING LIQUIDS PREVAIL** and insertion depth is over 16' or more, use a support extension with a rod guide—see illustration No. 1. Support extensions of specified lengths may be obtained from The Mercoid Corporation or made from 3/8" pipe, threaded at each end.

On installations where the control is to operate in a stand-pipe, no support extension is necessary and the float may be positioned at any point over the entire length of float rod.

**HOW TO ASSEMBLE FLOAT, ROD, STOPS**

If support extension is required, insert rod through rod guide bushing and support extensions. Attach float rod to coupling (illustrations No. 1 and 2) protruding from armature tube. Fasten support extension to armature tube by means of the threaded section inside of armature tube. Fasten rod guide bushing (with Teflon insert) to bottom of support extension. Place top float clamp (stop) on rod and fasten it at the desired position. Insert rod through float and secure to float rod by means of bottom float clamp (stop). Be sure that float is secured in position by both top and bottom clamps (stops) with no play between them. Location of float on the rod determines level effecting switch operation.

If support extension is not used, attach the float rod to the rod coupling and install float as described above.

**FOR OPERATING LEVELS AND DIFFERENTIALS  
SEE TABLES ON OPPOSITE PAGE**

**WIRING**

Wire in accordance with local electrical codes or follow equipment manufacturer's instructions.

On single stage controls, once the float has been positioned, the operating point can be adjusted slightly by loosening the BRASS screw and raising or lowering the switch assembly.

To remove or position switch assembly, loosen BRASS screw (illustration No. 2). Align wiring block to face conduit opening and tighten BRASS screw of switch assembly. Note that the 3/4" NPT conduit connection (on all types) can be rotated 360° to facilitate wiring.

**CAUTIONS**

Keep cover on control mechanism at all times. Do not oil any parts. Do not overload electrically—see rating stamped on nameplate.

**CIRCUIT ARRANGEMENTS - SINGLE STAGE  
Controls using mercury switch contacts**

OPERATING CIRCUIT SPEC. NO.	CIRCUIT ARRANGE- MENT	CIRCUIT RESPONSE TO LIQUID LEVEL CHANGES
No. 4820	SP-ST	Closes as level falls
No. 4821	SP-ST	Closes as level rises
No. 4815	SP-DT	One circuit closes as other circuit opens
No. 4814	DP-ST	Closes as level falls
No. 4813	DP-ST	Closes as level rises

**TWO-STAGE OPERATION  
(WITH MERCURY SWITCHES)**

Any two circuits shown in circuit arrangement table are available on each stage for 120-240 volts two stage operation, example, 4820-13 designates a SP-ST lower stage to close as level falls and a DP-ST upper stage open as level falls.

**CIRCUIT ARRANGEMENTS (MERCONTROL  
with snap-acting switches)**

**Single** - Specification No. 7810 (1) SP-DT Switch  
Specification No. 7806 (2) SP-DT Switches  
**Two** - Specification No. 7810-10 SP-DT Each Stage  
Specification No. 7810-06 SP-DT Each Stage  
Specification No. 7806-10 SP-DT Each Stage  
Specification No. 7806-06 SP-DT Each Stage

**FOR OPERATING LEVELS AND DIFFERENTIALS SEE TABLES ON OPPOSITE PAGE**

## LIQUID LEVEL CHANGES IN INCHES FOR SWITCH OPERATION

### SINGLE STAGE

SPECIFIC GRAVITY	FLOAT C - COPPER SS - STAINLESS STEEL	SINGLE STAGE		FIXED LEVEL CHANGE "D" BETWEEN ON AND OFF	MINIMUM TANK DEPTH REQUIRED BELOW LOW OPERATING POINT "TB"
		MINIMUM HIGH LEVEL OPERATING POINT (ON RISE) FROM TOP OF FLANGE	MAXIMUM LOW LEVEL OPERATING POINT (ON DROP) FROM TOP OF FLANGE		
1.0	4 1/2" C	9"	96"	3/4"	5 3/4"
	4 1/2" SS	9 3/8"	144"	3/4"	5 3/4"
	7" C	10 1/8"	286"	1/2"	6"
	7" SS	10 3/4"	286"	1/2"	6"
.90	3 1/2 x 6" SS	9 7/8"	144"	7/8"	7 5/8"
	4 1/2" C	8 3/4"	108"	7/8"	6 1/8"
	4 1/2" SS	9 1/4"	144"	1"	6 1/8"
	7" C	10"	286"	1/2"	6 1/4"
.82	7" SS	10 5/8"	286"	1/2"	6 1/4"
	3 1/2 x 6" SS	9 3/8"	96"	1 1/8"	7 7/8"
	4 1/2" C	8 1/2"	72"	1"	6 1/4"
	4 1/2" SS	8 3/4"	108"	7/8"	6 1/4"
.75	7" C	9 7/8"	286"	1/2"	6 3/4"
	7" SS	10 1/2"	286"	1/2"	6 3/4"
	3 1/2 x 6" SS	9 1/8"	72"	1 1/4"	8"
	4 1/2" C	7 1/2"	16"	1 3/8"	6 1/8"
.62	4 1/2" SS	8 3/8"	72"	1"	6 1/2"
	7" C	9 5/8"	286"	5/8"	6 7/8"
	7" SS	10 3/8"	286"	5/8"	6 7/8"
	3 1/2 x 6" SS	8 7/8"	48"	1 1/2"	8"
.50	7" C	8 3/4"	190"	3/4"	6 3/4"
	7" SS	9 3/4"	286"	3/4"	6 3/4"
50	7" SS	9 1/4"	286"	3/4"	6 3/4"

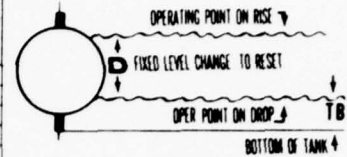

#### NOTE

Float travel is limited by the lower extremity of the armature tube, or when provided, by the end of the support extension. Float rods and extensions may be altered to obtain the minimum and maximum operating levels shown in the tables.

If control has been furnished for specified operating levels, the float rod supplied will provide  $\pm 2"$  adjustment of such levels.

If tank depth is critical a section of float rod below lower clamp (stop) may be cut off.

### TWO STAGE OPERATION

SPECIFIC GRAVITY	FLOAT C - COPPER SS - STAINLESS STEEL	UPPER STAGE		LOWER STAGE		LEVEL CHANGE BETWEEN STAGE OPERATIONS "F"	MINIMUM TANK DEPTH REQUIRED BELOW LOW OPERATING POINT "TB"
		MINIMUM OPERATING POINT FROM TOP OF FLANGE (ON RISE)	FIXED LEVEL CHANGE "C" TO RESET ON DROP	MAXIMUM OPERATING POINT FROM TOP OF FLANGE (ON DROP)	FIXED LEVEL CHANGE "B" TO RESET ON RISE		
1.0	4 1/2" C	8"	1 1/4"	73"	3/4"	2 1/4"	5 3/4"
	4 1/2" SS	7 1/4"	1 3/8"	145"	3/4"	2 1/4 3"	5 3/4"
	7" C	9"	3/4"	286"	1/2"	2 1/8"	6"
	7" SS	10"	3/4"	286"	1/2"	2 1/16"	6"
.90	3 1/2 x 6" SS	8"	1 1/2"	108"	7/8"	2 1/4"	7 5/8"
	4 1/2" C	7 3/8"	1 3/8"	66"	3/4"	2 1/4"	6 1/4"
	4 1/2" SS	7 1/8"	1 1/4"	96"	3/4"	2 1/4 3"	6 1/4"
	7" C	9"	3/4"	286"	1/2"	2 1/8"	6 1/4"
.82	7" SS	10"	3/4"	286"	1/2"	2 1/8"	6 1/4"
	3 1/2 x 6" SS	7 1/8"	1 1/2"	72"	1"	2 1/4"	8"
	4 1/2" C	7"	1 1/2"	48"	7/8"	2 1/4"	6 3/8"
	4 1/2" SS	7"	1 1/4"	72"	7/8"	2 1/4 3"	6 3/8"
.75	7" C	9"	7/8"	286"	5/8"	2 1/8"	6 5/8"
	7" SS	10"	7/8"	286"	5/8"	2 1/8"	6 5/8"
	3 1/2 x 6" SS	7"	1 5/8"	48"	1 1/4"	2 1/4"	8"
	4 1/2" SS	7"	1 1/8"	49"	3/4"	2 1/4 3"	6 3/4"
.62	7" C	8"	7/8"	286"	5/8"	2 1/8"	6 7/8"
	7" SS	10"	7/8"	286"	5/8"	2 1/8"	6 7/8"
.50	3 1/2 x 6" SS	7"	1 3/4"	24"	1 1/4"	2 1/4"	8 1/4"
	7" C	7 1/4"	1"	215"	3/4"	2 1/4"	7 3/4"
	7" SS	9"	1"	286"	5/8"	2 3/16"	7 3/4"
	7" SS	8 1/4"	1"	269"	3/4"	2 1/4"	7 3/4"

#### NOTE

Float travel is limited by the lower extremity of the armature tube, or when provided, by the end of the support extension. Float rods and extensions may be altered to obtain the minimum and maximum operating levels shown in the tables.

If control has been furnished for specified operating levels, the float rod supplied will provide  $\pm 2"$  adjustment of such levels.

If tank depth is critical a section of float rod below lower clamp (stop) may be cut off.

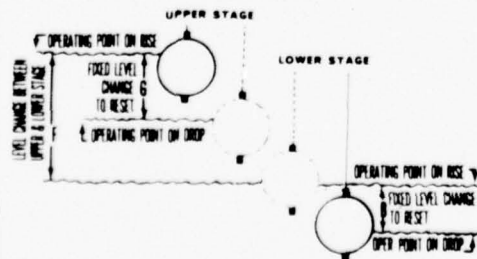

**THE MERCID CORPORATION, 4201 BELMONT AVE., CHICAGO, ILL. 60641**

628 Davisville Road, Willow Grove, Penna. 19090

315 Montgomery Street, San Francisco, California 94104

MERCID - Reg. Trade Mark - Marca Registrada - Marque Déposée - Marca Registrada - Marchio Registrato - Registrat Varemeye - Eingetragenes Warenzeichen - United States of America, Great Britain, Canada, Argentina, Chile, Honduras, Mexico, Peru, Uruguay, Brazil, Venezuela, France, Italy, Spain, Sweden, Denmark, Norway, Belgium, Holland, West Germany.

Printed in U.S.A. 10-72 NP

BULLETIN NO. 6-420A





## MERCOID SERIES 401 MAGNETIC LIQUID LEVEL CONTROLS

TOP MOUNTING—FOR PRESSURIZED OR NON-PRESSURIZED TANKS OR SUMPS

### INSTALLATION INSTRUCTIONS

#### APPLICATION

- SERIES 401-1 Single Stage Operation—Adjustable high and low operating levels.
- SERIES 401-2 Two Stage Operation—Adjustable operating levels plus high level alarm or trip.
- SERIES 401-3 Two Stage Operation—Adjustable operating levels plus low level alarm or trip.
- SERIES 401-4 Two Stage Operation—High and low alarm or trip with adjustable spread between stages.

#### OPERATION

Mercoid Series 401 Controls incorporate magnetically actuated switch mechanisms which are operated by a magnetic armature placed by float action into or out of the magnetic field of the switch magnet. The armature operates within a nonmagnetic tube within the switch enclosure. The switch mechanism (including the tilting Mercoid mercury switches) are mounted on the armature tube. Poles of the switch magnets face the armature tube and when float action moves the armature into position to attract the magnet, tilting of the mercury switches takes place. As the armature is moved out of position, the magnetic attraction is broken and the mercury switches tilt back to the original position. The armature tube and switch structures are designed so that two switch mechanisms may be stacked on the tube, each responsive to different float levels for individual two stage operation.

#### ENCLOSURES

General Purpose enclosures are identified by the letter "G" in type number as in 401-1G. Weather Resistant enclosures are identified by the letter "W" in type number as in 401-1W. Explosion-Proof enclosures are identified by the letter "E" in type number as in 401-1E.

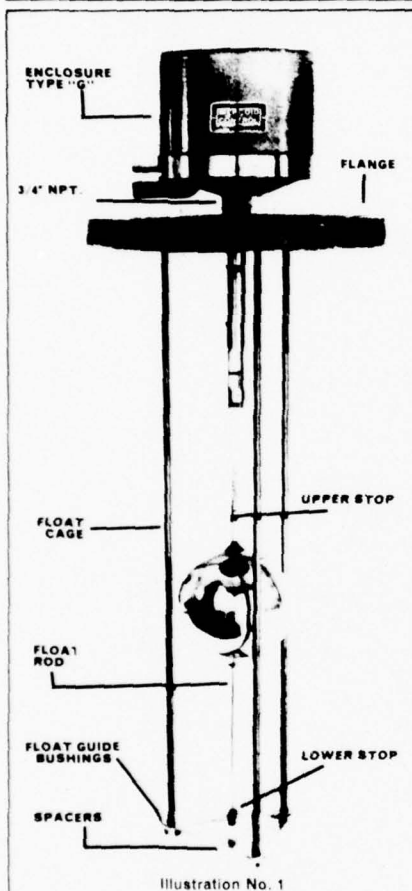

Illustration No. 1

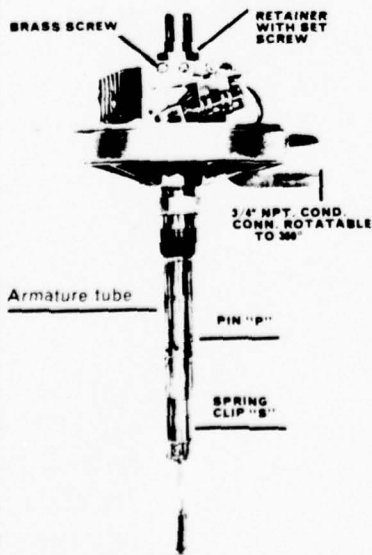

Illustration No. 2

FLOATS—(PRESSURE AND TEMPERATURE RATINGS)		
4-1 2" Copper	150 PSI @ 300 F. MAX.	(NO. 45-43-1)
4-1 2" 304 S.S.	300 PSI @ 500 F. MAX. 600 PSI @ 500 F. MAX.	(NO. 45-30)
3-1 2 x 6" S.S.	300 PSI @ 500 F. MAX. 450 PSI @ 100 F. MAX.	NO. 45-97SS
7" Copper	150 PSI @ 300 F. MAX.	(NO. 45-49)
7" 304 S.S.	450 PSI @ 100 F. MAX. 425 PSI @ 200 F. MAX. 300 PSI @ 500 F. MAX.	(NO. 45-50)

MAX. TEMP. INSIDE CONTROL—250°F.

FLANGES (ASA SPECIFICATIONS)		
4-1 2" Float	STEAM	COLD NON-SHOCK
6" Cast Iron	125#	175#
6" Cast Iron (Heavy Duty)	250#	400#
6" Forged Steel	300#	600#
5" Flange for 3-1/2" x 6" FLOAT same ratings as above.		
8" Flange for 7" FLOAT same ratings as above.		

#### MOUNTING

Select location recommended by equipment manufacturer. Be sure opening in vessel is large enough so that the float and float cage (if used) are properly contained. Before installing, check nameplate for Type Number and Circuit Specification Number and follow instructions under each specific type as shown on the following pages.

The guide rods for the float cage are 3/16" in diameter and threaded on one end for screwing into tappings of the flange. The float guide rod spacers are held in place by a bushing at the bottom of the rod. Float guide rods may be shortened to the desired length by using a hacksaw. NOTE—if float is to operate in a suitable standpipe, guide rods are not necessary.

#### CAUTIONS

Be sure switch mechanism is mounted in a vertical position. Keep cover on control head at all times. Never oil switch mechanism. Do not overload—see electrical rating on nameplate.

Weather-Proof Types (W) are provided with drain (vent) hole in bottom of enclosure base which must be kept open. Explosion-Proof (E), observe cover instructions.

**IMPORTANT**—On two-stage units the upper and lower mercury switch assemblies are not interchangeable with the exception of circuit specification No. 4815 (SP-DT.) Interchanging two-stage units will reverse switch action from that obtained in its original position—see circuit response table for respective upper and lower units under each specific type number.

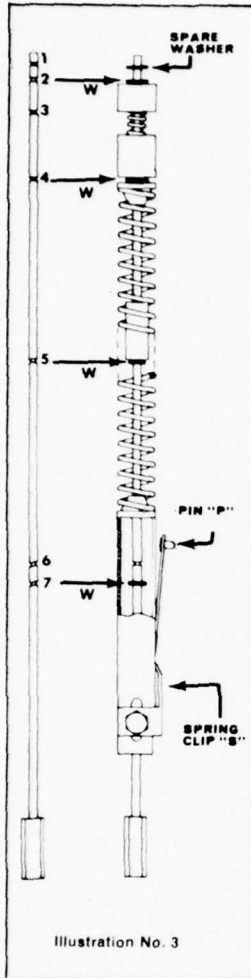

Illustration No. 3

**MERCOID TYPE 401-1 SINGLE STAGE OPERATION**  
Adjustable High and Low Operating Levels

**MERCOID TYPE 401-2 TWO STAGE OPERATION**  
Adjustable Operating Levels Plus High Level Alarm or Trip

Before installing, check armature rod assembly (illustration Nos. 2 and 3). Press down on the adjusting SPRING CLIP "S" which releases PIN "P" and pull out entire armature rod assembly. Check to see that SNAP WASHERS "W" are properly located in slots as indicated by illustration No. 2. A SNAP WASHER "W" must be in slots 2, 4, 5 and 7. Note that an extra washer is located in slot No. 1 which serves no purpose except as a spare washer. The other components must also be positioned as shown.

After determining that the assembly is correct, note the four holes on the armature tube marked 2, 5, 8, 10 above designation "401-1 or 2". Insert PIN "P" in proper hole in accordance with table shown on right.

Assemble switch mechanism (illustration No. 2) to mounting flange or other mounting method. Do not twist the control case by hand, use a wrench on the hex section of the 3/4" NPT connection. Connect float rod to armature rod and lock with coupling nut. Place float on rod with upper and lower float stops. Secure float stops in place for low and high level operation. Note float diagram and level change table for high and low level limitations.

For the initial settings of float stops for operating levels, it may be assumed that level line on float is at center of float. Stop may be positioned to locate center of float at the desired level distances from top of mounting flange. Float level line will vary somewhat in operation and with respect to differences in floats and specific gravities. Note that for Type 401-2 the top and bottom float stops determine the operating levels "A" and "B" for the lower mercury switch unit. The top mercury switch unit operates upon a fixed level rise above "A". (See float diagram, dimension "C".)

Assemble guide rods to flange and secure their bottom ends together with the spacers and clamps provided (illustration No. 1). Insert float structure into vessel and bolt flange into place.

**TO REMOVE MERCURY SWITCH ASSEMBLY**

The mercury switch mechanism is easily removed. First loosening set screw in retainer ring (illustration No. 2) after which, loosen the brass screw and lift up entire assembly. When reassembling be sure switch mechanism is positioned at the bottom of the armature tube within the control case. Note: Where two mercury switch assemblies are used (Type 401-2) the first switch assembly must be positioned at the bottom of the armature tube and follow this by positioning second switch assembly on top of the first one—second assembly must also be as far down on the armature tube as possible. This is important as incorrect positioning can result in operating failures. The switch magnets must assume their proper relationship to the armature within the armature tube as it is raised and lowered by float action.

Align wiring block to face conduit opening and tighten brass screw to secure switch mechanism into place. Replace retainer ring and tighten with set screw.

**WIRING**

Wire in accordance with local electrical codes. Make sure that each mercury switch unit is properly positioned as explained in preceding paragraph.

**CAUTIONS** See page 1.

FLOAT ROD LENGTH	HOLE NUMBER
Up to 3 ft.	2
Over 3 ft. to 6 ft.	5
Over 6 ft. to 9 ft.	8
Over 9 ft.	10

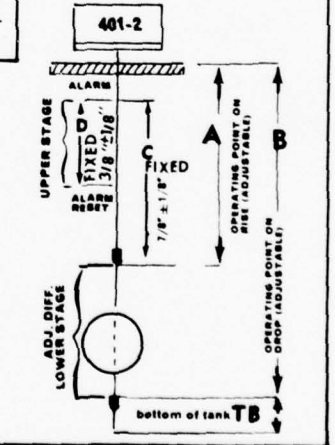
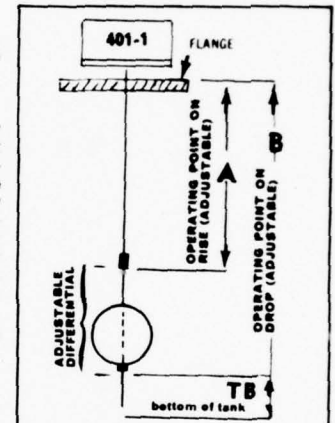

**TYPE 401-1 SINGLE STAGE**  
**CIRCUIT ARRANGEMENTS**

CIRCUIT ARRANGEMENT	CIRCUIT RESPONSE TO LIQUID LEVEL CHANGES	Spec. No.
SP-ST	Open on level DROP Close on level RISE	No. 4820
SP-ST	Open on level RISE Close on level DROP	No. 4821
SP-DT	One circuit OPENS as other circuit CLOSES	No. 4815
DP-ST	Close on level RISE Open on level DROP	No. 4814
DP-ST	Open on level RISE Close on level DROP	No. 4813

**TYPE 401-2 TWO-STAGE**  
**CIRCUIT ARRANGEMENTS**

CIRCUIT ARRANGEMENT	CIRCUIT RESPONSE TO LIQUID LEVEL CHANGES	LOWER STAGE		UPPER STAGE
		OPERATING CIRCUIT SPEC. NO.	ALARM OR TRIP SPEC. NO.	ALARM OR TRIP SPEC. NO.
SP-ST	Open on level DROP Close on level RISE	No. 4820	-21	
SP-ST	Open on level RISE Close on level DROP	No. 4821	-20	
SP-DT	One circuit OPENS as other circuit CLOSES	No. 4815	-15	
DP-ST	Close on level RISE Open on level DROP	No. 4814	-13	
DP-ST	Open on level RISE Close on level DROP	No. 4813	-14	

NOTE: Any operating circuit can be combined with any alarm or trip circuit, i.e. 4820-13.

**MAXIMUM & MINIMUM OPERATING DEPTHS IN INCHES BELOW TOP OF FLANGE**  
**FOR STANDARD GUIDE ROD LENGTHS AT VARIOUS SPECIFIC GRAVITIES**

TYPE NO.	FLOATS C - Copper SS - Stainless Steel	MINIMUM		MAXIMUM FOR "B"—DISTANCE BELOW TOP OF FLANGE FOR OPERATION											
		"A"	"B"	Sp. Gr. 1.0				Sp. Gr. 1.2				Sp. Gr. 1.5			
				GUIDE RODS											
		Slightly less for 72, 82, 85													
401-1 401-2	3-1/2"x6" SS	13	15	45	93	141	44-1/2	92-1/2	126-1/2	N.A.	N.A.	N.A.	N.A.	N.A.	
	4-1/2" C	12-1/2	14	46	94	N.A.	N.A.	N.A.	N.A.	N.A.	N.A.	N.A.	N.A.	N.A.	
	4-1/2" SS	13	14	46-1/2	94-1/2	142-1/2	46	N.A.	N.A.	N.A.	N.A.	N.A.	N.A.	N.A.	
	7" C	14-1/2	15-1/2	45-1/2	93-1/2	142	45	93	141	44	92	140	N.A.	N.A.	
	7" SS	15	16	46	94	142	46	94	142	45-1/2	93-1/2	141-1/2	44-1/2	92-1/2	

**MERCOID TYPE 401-3 TWO STAGE OPERATION**  
Adjustable Operating Levels Plus Low Level Alarm or Trip

Before installing check armature rod assembly (illustration No. 4). Press down on the adjusting SPRING CLIP "S" which releases PIN "P" and pull out entire armature rod assembly. Check to see that SNAP WASHERS "W" are properly located in slots as indicated by illustration No. 4. A SNAP WASHER "W" must be in slots 1, 4, 5 and 6. The other components must also be positioned as shown.

After determining that the assembly is correct, note the four holes on armature tube, marked 3, 6, 9, 12 above designation "401-3". Insert PIN "P" into proper hole in accordance with table shown on right.

FLOAT ROD LENGTH	HOLE NUMBER
Up to 4 ft.	3
Over 4 ft. to 7 ft.	6
Over 7 ft. to 10 ft.	9
Over 10 ft.	12

Assemble switch mechanism (see illustration No. 2 page 1) to mounting flange or other mounting. Do not twist the control case by hand, use a wrench on the hex section of the 3/4" NPT connection. Connect float rod to armature rod and lock with coupling nut. Place float on rod with upper and lower float stops.

Fasten stops in place for low and high level operation. Note float diagram and level change chart for high and low level limitations. For the initial settings of float stops for operating levels, it may be assumed that level line on float is at center of float. Stop may be positioned to locate center of float at the desired level distance from top of flange mounting. Float level line will vary somewhat in operation and with respect to differences in floats and specific gravities. For the Type 401-3 the top and bottom float stops determine the operating levels of "A" and "B" for the upper mercury switch mechanism. The lower mercury switch mechanism operates upon a fixed level drop below level "B" (see float diagram dimension "C").

Assemble guide rods to flange and secure their bottom ends together with the spacers and clamps provided (see illustration No. 1, page 1). Insert float structure into vessel and bolt flange into place.

**TO REMOVE MERCURY SWITCH ASSEMBLIES**

Switch mechanism consists of two mercury switch assemblies. First loosen set screw in retainer ring (see illustration No. 3, page 2). Note—illustration only shows one mercury switch assembly. Remove retainer ring. Loosen brass screw on each of the mercury switch assemblies, after which lift up assemblies to remove.

When reassembling, be sure that the first mercury switch assembly is positioned at the bottom of the armature tube within the control case. Follow this by positioning the second mercury switch assembly on top of the first one making sure it also is as far down on the armature tube as possible. The correct placement of the two switch assemblies is important for an incorrect position can result in operating failure. The switch magnets must assume their proper relationship to the armature within the armature tube as it is raised and lowered by float action.

Align wiring block to face conduit opening and tighten brass screw in each switch assembly to secure it in place. Replace retainer ring and tighten set screw.

**WIRING**

Wire in accordance with local electrical codes. Make sure that both mercury switch assemblies are in correct position as noted in preceding paragraph.

**CAUTIONS** See page 1.

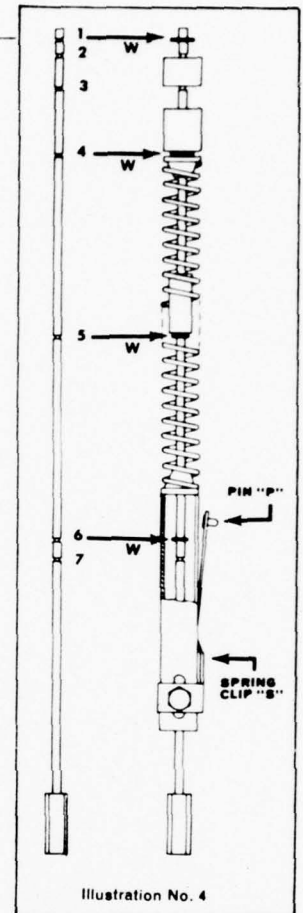
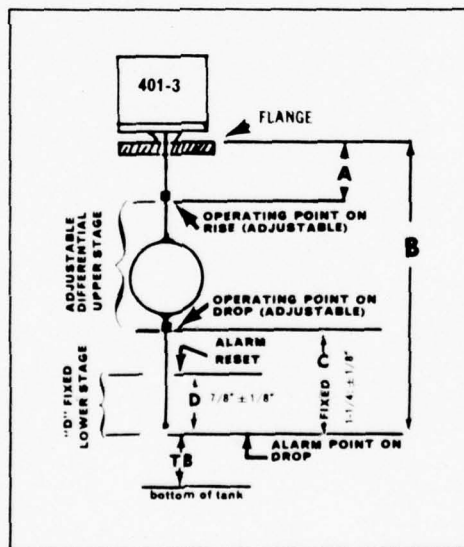

CIRCUIT ARRANGEMENTS		LOWER STAGE	UPPER STAGE
CIRCUIT ARRANGEMENT	CIRCUIT RESPONSE TO LIQUID LEVEL CHANGES	ALARM OR TRIP SPEC. NO.	OPERATING CIRCUIT SPEC. NO.
SP-ST	Open on level DROP Close on level RISE	No. 4820	-21
SP-ST	Open on level RISE Close on level DROP	No. 4821	-30
SP-DT	One circuit CLOSES as other circuit OPENS	No. 4815	-15
DP-ST	Close on level RISE Open on level DROP	No. 4814	-13
DP-ST	Open on level RISE Close on level DROP	No. 4813	-14

NOTE: Any operating circuit can be combined with any alarm or trip circuit, i.e. 4820-13.

ELECTRICAL RATING: 10 amp. 120 volts, 5 amp. 240 volts AC or DC. Available 440 volts 3 amp. AC. —two stage limited to SP-ST in each stage.

MAXIMUM & MINIMUM OPERATING DEPTHS IN INCHES BELOW TOP OF FLANGE FOR STANDARD GUIDE ROD LENGTHS AT VARIOUS SPECIFIC GRAVITIES															
TYPE NO.	FLOATS C = Copper SS = Stainless Steel	MINIMUM		MAXIMUM FOR "B"—DISTANCE BELOW TOP OF FLANGE FOR OPERATION											
		"A"	"B"	Sp. Gr. 1.0			Sp. Gr. .72			Sp. Gr. .82			Sp. Gr. .5		
				GUIDE RODS			GUIDE RODS			GUIDE RODS			GUIDE RODS		
				4'	8'	12'	4'	8'	12'	4'	8'	12'	4'	8'	12'
401-3	3-1/2" x 6" SS	12	10	45	93	141	N.A.	N.A.	N.A.	N.A.	N.A.	N.A.	N.A.	N.A.	
	4-1/2" C	11-1/2	14	44-1/2	92-1/2	N.A.	N.A.	N.A.	N.A.	N.A.	N.A.	N.A.	N.A.	N.A.	
	4-1/2" SS	11-1/2	14-1/2	45	93	141	44-1/2	N.A.	N.A.	N.A.	N.A.	N.A.	N.A.	N.A.	
	7" C	13-1/2	15-1/2	44	92	140	43-1/2	91-1/2	139-1/2	43	91	139	N.A.	N.A.	
7" SS	14	16	44-1/2	92-1/2	142-1/2	44-1/2	92-1/2	140-1/2	44	92	140	44	92	140	

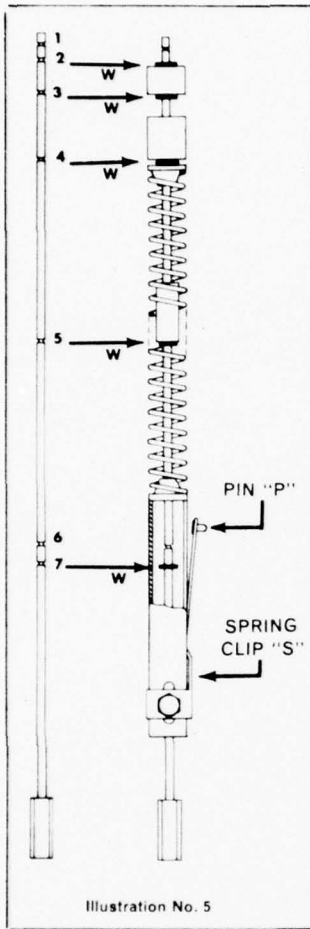

Illustration No. 5

### MERCROID TYPE 401-4 TWO STAGE OPERATION High and Low Alarm or Trip With Adjustable Spread Between Stages

Before installing, check armature rod assembly (illustration No. 5). Press down on the adjusting SPRING CLIP "S" which releases PIN "P", and pull out entire armature rod assembly. Check to see that SNAP WASHERS "W" are properly located in slots as indicated by illustration No. 5. A SNAP WASHER "W" must be in slots 2, 3, 4, 5 and 7. The other components must also be positioned as shown.

After determining that the assembly is correct note the four holes on armature tube marked 3, 6, 9, 12 above designation "401-4". Insert PIN "P" into proper hole in accordance with the following table:

FLOAT ROD LENGTH	HOLE NUMBER
Up to 4 ft.	3
Over 4 ft. to 7 ft.	6
Over 7 ft. to 10 ft.	9
Over 10 ft.	12

Assemble switch mechanism (unit) to mounting flange or other mounting. Do not twist the control case by hand, use a wrench on the hex section of the 3/4" N.P.T. connection. Connect float rod to armature rod and lock with coupling nut. Place float rod with upper and lower float stops. Clamp float stops in place for low and high level operation. Note float diagram and level change chart for high and low level limitations. For the purpose of estimating level position of float for setting float stops, assume liquid level at center of float.

Float level line will vary somewhat in operation and with respect to differences in floats and specific gravity. For type 401-4 the Top and Bottom float stops determine the operating levels "A" (upper switch assembly) and "B" (lower switch assembly). Each mercury switch assembly has a fixed operating differential "C" and "D" (see float diagram dimension).

Assemble guide rods to flange and secure their bottom ends together with the spacers and clamps provided (see illustration No. 1, page 1). Insert float structure into vessel and bolt flange into place.

#### TO REMOVE MERCURY SWITCH ASSEMBLIES

Switch mechanism consists of two mercury switch assemblies. First loosen set screw in retainer ring (see illustration No 2, page 1). Note that illustration only shows one mercury switch assembly. Remove retainer ring. Loosen brass screw on each of the mercury switch assemblies, after which, lift up assemblies to remove. When reassembling, be sure that the first mercury switch assembly is positioned at the bottom of the armature tube within the control case. Follow this by positioning the second mercury switch assembly on top of the first one and be sure it is as far down on the armature tube as possible. Align wiring blocks to face conduit opening and tighten brass screw in each switch assembly to secure it in place. Replace retainer ring on top of assembly and tighten set screw. The correct placement of the two switch assemblies is important for an incorrect position can result in operating failures. The switch magnets must assume their proper relationship to the armature within the armature tube as it is raised and lowered by float action.

#### CIRCUIT ARRANGEMENTS-

CIRCUIT ARRANGEMENT	CIRCUIT RESPONSE TO LIQUID LEVEL CHANGE	LOWER STAGE	UPPER STAGE
		LOW LEVEL ALARM OR TRIP SPEC. NO.	HIGH LEVEL ALARM OR TRIP SPEC. NO.
SP-ST	Open on level DROP Close on level RISE	No. 4820	-21
SP-ST	Open on level RISE Close on level DROP	No. 4821	-20
SP-DT	One circuit CLOSES other circuit OPENS	No. 4815	-15
DP-ST	Close on level RISE Open on level DROP	No. 4814	-13
DP-ST	Open on level RISE Close on level DROP	No. 4813	-14

Note: Any operating circuit can be combined with an alarm or trip circuit, i.e.—4821-20

ELECTRICAL RATING: 10 amp, 120 volts, 5 amp, 240 volts AC or DC. Available 440 volts 3 amp. AC.—two stage limited to SP-ST in each stage.

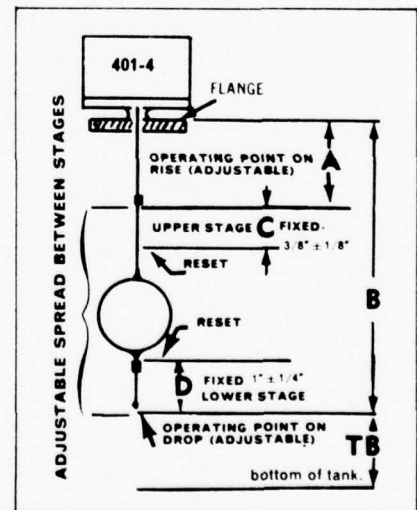

#### MAXIMUM & MINIMUM OPERATING DEPTHS IN INCHES BELOW TOP OF FLANGE FOR STANDARD GUIDE ROD LENGTHS AT VARIOUS SPECIFIC GRAVITIES

TYPE NO.	FLOATS C - Copper SS - Stainless Steel	MAXIMUM FOR "B" - DISTANCE BELOW TOP OF FLANGE FOR OPERATION													
		MINIMUM		Sp. Gr. 1.0			Sp. Gr. 72			Sp. Gr. 82			Sp. Gr. 3		
		"A"	"B"	GUIDE RODS			GUIDE RODS			GUIDE RODS			GUIDE RODS		
				4'	8'	12'	4'	8'	12'	4'	8'	12'	4'	8'	12'
401-4	3-1/2"x8" SS	12	15-1/2	45	93	141	N.A.	N.A.	N.A.	N.A.	N.A.	N.A.	N.A.	N.A.	N.A.
	4-1/2" C	11-1/2	14-1/2	46-1/2	94-1/2	N.A.	N.A.	N.A.	N.A.	N.A.	N.A.	N.A.	N.A.	N.A.	N.A.
	4-1/2" SS	12	14-1/2	47	95	143	N.A.	N.A.	N.A.	N.A.	N.A.	N.A.	N.A.	N.A.	N.A.
	T' C	13-1/2	15-1/2	45-1/2	93-1/2	141-1/2	45	93	141	44-1/2	92-1/2	140-1/2	N.A.	N.A.	N.A.
	T' SS	14-1/2	16-1/2	46	94	142	46	94	142	45-1/2	93-1/2	141-1/2	45	93	141

APPENDIX A-4

MAGNETROL DIVISION LIQUID LEVEL CONTROLS

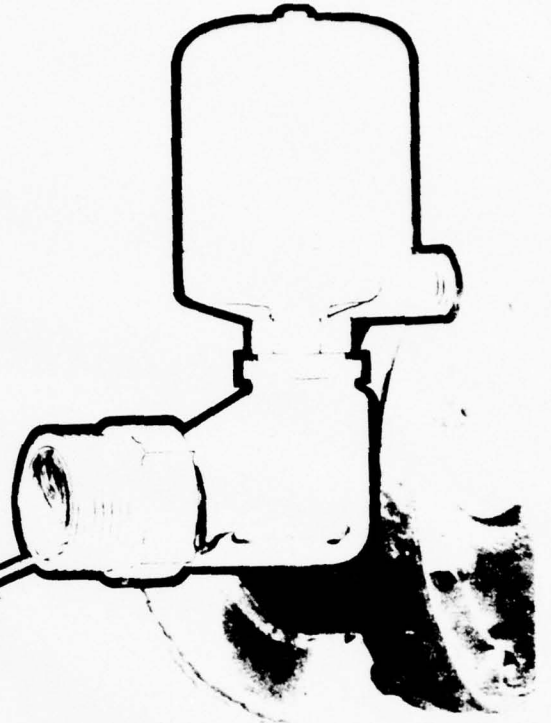
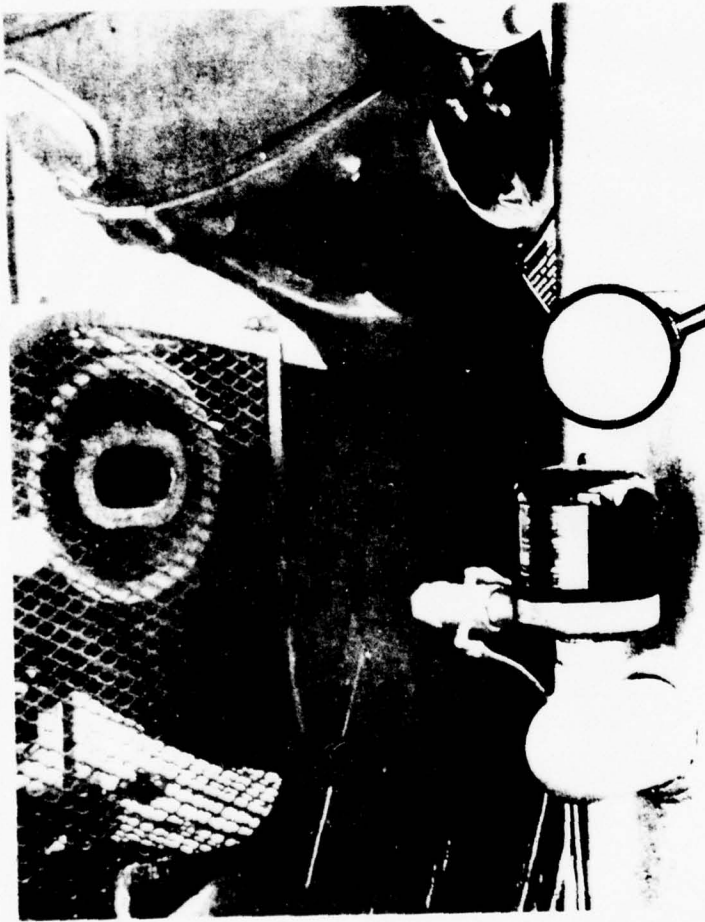

®

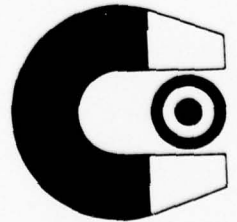



## MAGNETROL SIDE MOUNTING TYPE LIQUID LEVEL CONTROLS

Worldwide acceptance of Magnetrol products stems from an unequaled application capability and total commitment to fulfilling industry's need for reliable level and flow instrumentation.

Magnetrol instruments have built an enviable performance record throughout three decades in the most demanding of services . . . from nuclear power plants, petroleum and chemical processing to pulp and paper manufacturing, food processing and national defense projects.

Whether your installation calls for a standard instrument or a specialized design — solving your application is a special challenge to us — level and flow instrumentation is our only business.

These simple, reliable Magnetrol instruments mount horizontally to any tank or vessel through a threaded or flanged pipe connection. Standard models are normally equipped with a single switch mechanism for high or low level alarm or control applications. Tandem models with two switch mechanisms are available for two level stage applications providing the operating functions of two separate instruments, such as high and low level alarm.

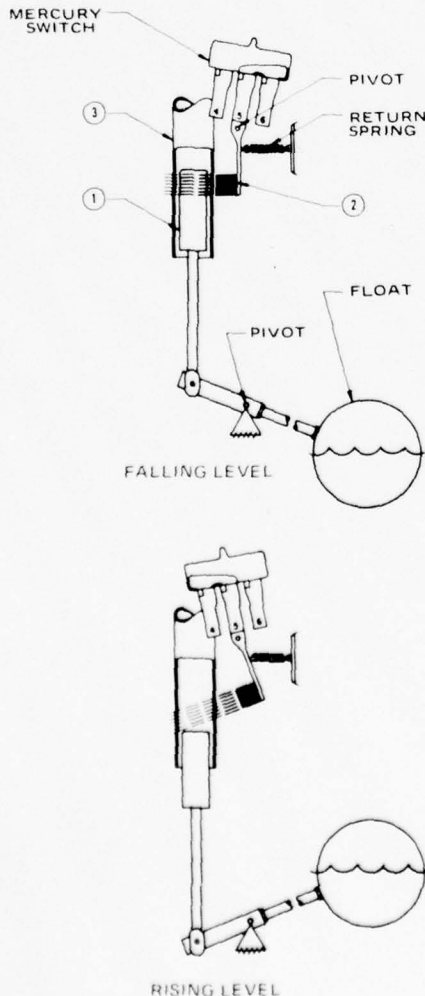

## ENGINEERING FEATURES

Side mounting Magnetrol level controls offer many useful engineering features designed to provide the utmost in application versatility. Several of the most popular application features are listed here.

**CHOICE OF DIFFERENTIAL . . .** The desired level change between switch off to on is easily selected simply by specifying the appropriate float stem length. Most models are available with up to 15½" of level differential, which is field adjustable.

**TANDEM OPERATION . . .** When specified, dual switches are available for tandem operation combining the operating functions of two separate level controls in one compact easy to install instrument.

**CHOICE OF SWITCH MECHANISM . . .** A variety of optional switch mechanisms are available to meet virtually any job requirement including dry contact switches, double pole mercury switches and pneumatic pilot switches. Details on page 7.

**WIDE SPECIFIC GRAVITY RANGES . . .** Standard side mounting Magnetrol units are available for service on liquids of 0.40 or greater specific gravity. Lower ratings are possible when a specially counterweighted float is specified.

**FLANGED OR THREADED MOUNTING . . .** For maximum installation versatility, standard models are available with flanged or threaded mounting in either cast iron or steel construction.

**OUTSTANDING ECONOMY . . .** Low first cost, simple mounting and dependable operation account for the outstanding service economies offered by side mounting Magnetrol instruments.

## OPERATING PRINCIPLE

Like all Magnetrol instruments, side mounting units employ permanent magnetic force as the *only* link between the float and the switching element. As the pivoted float follows liquid level changes, it moves a magnetic sleeve (1) into or out of the field of a switch actuating magnet (2) causing switch operation. A non-magnetic barrier tube (3) effectively isolates the switch mechanism from the controlled liquid, eliminating the need for flexing bellows seals, or failure prone packing glands.

Magnetrol's magnetic operating principle is the product of over three decades of continuous refinement and improvement. Its peerless reliability — applied through dedicated application engineering and quality construction is the underlying reason for Magnetrol's enviable performance record.

## MODEL FINDER

Body Material	Mounting Style	Model No.	Page No.
Cast Iron	Threaded	TF 63	3
	Flanged	TF 52	4
Fabricated Steel	Threaded	TF 62	5
	Flanged	TF 62 F	6

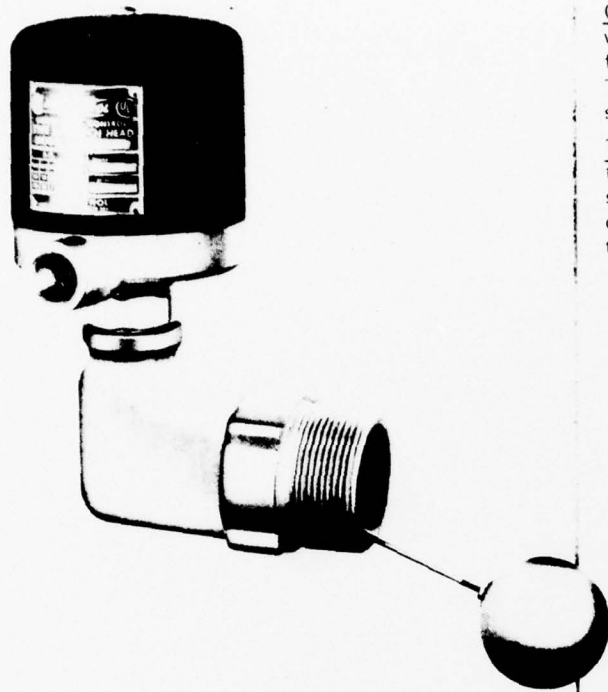

**MODEL TF-63**  
Cast Iron Body, 2 1/2" NPT Mounting Connection

Low first cost coupled with application versatility have made the Model TF-63 the most popular side mounting liquid level control. It is ideal for applications involving high or low level alarm or pump control, and is suitable for open tank or pressurized applications.

**SPECIFICATIONS**

**Switch Mechanism** . . . One Type S-1 mercury switch mechanism with SPST contacts is standard, others available. Details on page 7.

**Switch Enclosure** . . . NEMA 1 standard, others available.

**Body** . . . Cast iron with 2 1/2" NPT male pipe thread is standard. Other materials available.

**Float and Trim** . . . Standard materials include a 2 1/2" dia. copper float with brass and Type 304 stainless steel trim components. The standard magnetic sleeve is of 400 series S.S. Optional floats are available as listed in the table at right. Optional trim materials are also available.

**PRESSURE TEMPERATURE RATINGS**  
Float size and material as well as body material affect pressure temperature rating of the control as indicated in the tables at right.

**OPTIONAL FEATURES**

**Switches** . . . SPDT mercury switches as well as dry contact types and pneumatic pilot switches are available. Page 7 details the most popular switch options.

**Switch Enclosures** . . . Standard options include splash proof, moisture proof and explosion proof types. Special designs are available to meet virtually any NEMA designation.

**Construction Materials** . . . The Model TF-63 is available with complete Type 304 or Type 316 S.S. float and trim for corrosive liquid applications. Bronze, Type 304 and Type 316 S.S. bodies may also be specified as well as a stainless steel sheathed magnetic sleeve.

**Tandem Operation** . . . The Model TF-63 is available for tandem operation (two switch mechanisms) providing the same functions as two single units, and can be factory calibrated to give individual switching actions throughout the range of float travel.

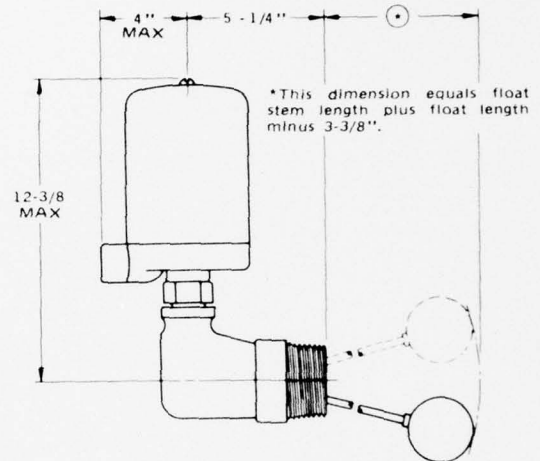

**FLOAT RATINGS**  
**SPECIFIC GRAVITY AND PRESSURE**

Material	Size (inches)	Minimum Specific Gravity				Pressure Rating PSI ①	
		Length of Float Stem				At 100°F	Maximum
Copper	2 1/2 dia.	.90	.90	.95	.95	50	25@250°F
	2 1/2 x 4	.50	.50	.55	.60	50	25@250°F
	3 dia. ②	.70	.70	.70	.75	200	50@300°F
Type 304/316 Stainless Steel	2 1/2 dia.	.80	.80	.80	.85	350	200@750°F
	2 1/2 x 4	.50	.50	.50	.55	100	60@750°F
	3 dia. ②	.55	.55	.55	.60	250	150@750°F

- ① Body pressure rating must also be considered. See table below. Lowest rating determines maximum pressure temperature limit.
- ② Can be used only where float can be attached from inside of tank. Float cannot pass through 2 1/2" NPT opening.

**BODY PRESSURE RATINGS (PSI)**

Body Material	Pressure Rating PSI	
	At 100°F	Maximum
Cast Iron	250	150 @ 450°F
Cast Bronze	250	125 @ 550°F
Cast Stainless Steel	400	200 @ 450°F

**LEVEL DIFFERENTIALS ③**

Length Of Float Stem	Adjustable Differential	
	Minimum	Maximum ④
6"	1"	4"
12"	1 1/2"	7 1/2"
18"	2 1/2"	11"
26"	3 1/2"	15 1/2"

- ③ All models factory set with minimum differential unless otherwise specified.
- ④ Length of mounting nozzle on tank limits maximum differential. Application details in Bulletin 44-320.



**MODEL TF-52**  
Cast Iron Body, Flanged Mounting Connection

The Magnetrol Model TF-52 parallels the Model TF-63 in basic design and application scope but differs by providing a special purpose flanged tank connection. The flange requires four bolt-studs on a 4 1/8" bolt circle to secure the instrument to the tank wall as illustrated in the diagram.

**SPECIFICATIONS**

**Switch Mechanism** . . . One Type S-1 mercury switch mechanism with SPST contacts is standard. Page 7 details optionally available switches.

**Switch Enclosure** . . . NEMA 1 is standard; others available.

**Body** . . . A cast iron body with special purpose mounting flange is standard. A bronze body is optionally available.

**Float and Trim** . . . A 2 1/2" diameter copper float with brass and Type 304 stainless steel trim components are standard. Standard magnetic sleeve is 400 series stainless steel. Optional floats are listed in the table at right. Optional trim materials are given below.

**PRESSURE-TEMPERATURE RATINGS**

Float size and material as well as body material affect pressure-temperature rating of the control as indicated in the table at right.

**OPTIONAL FEATURES**

**Switches** . . . SPDT mercury switches as well as dry contact types and pneumatic pilot switches are available. Page 7 details the most popular switch options.

**Switch Enclosures** . . . Standard options include splash proof, moisture proof and explosion proof types. Special designs are available to meet virtually any NEMA designation.

**Construction Materials** . . . Complete Type 304 or 316 S.S. float and trim are available for corrosive service applications. A bronze body is also available as well as a stainless steel sheathed magnetic sleeve.

**Tandem Operation** . . . The Model TF-52 is available for tandem operation (two switch mechanisms) providing the same functions as two single units, and can be factory calibrated to give individual switching actions throughout the range of float travel.

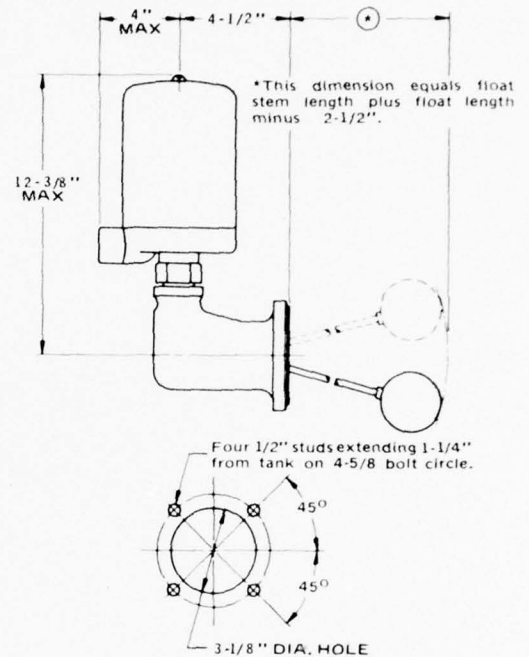

**FLOAT RATINGS**  
**SPECIFIC GRAVITY AND PRESSURE**

Material	Size (inches)	Minimum Specific Gravity				Pressure Rating PSI ①	
		Length of Float Stem				At 100°F	Maximum
		6"	12"	18"	26"		
Copper	2 1/2 dia.	.90	.90	.95	.95	50	25@250°F
	2 1/2 x 4	.50	.50	.55	.60	50	25@250°F
	3 dia.	.70	.70	.70	.75	200	50@300°F
Stainless Steel Types 304/316	2 1/2 dia.	.80	.80	.80	.85	350	200@750°F
	2 1/2 x 4	.50	.50	.50	.55	100	60@750°F
	3 dia.	.55	.55	.55	.60	250	150@750°F

① Body pressure rating must also be considered. See table below. Lowest rating determines maximum pressure-temperature limit.

**BODY PRESSURE RATINGS**

Body Material	Pressure Rating PSI	
	At 100°F	Maximum
Cast Iron	250	150 @ 450°F
Cast Bronze	250	125 @ 550°F

**LEVEL DIFFERENTIALS ②**

Length Of Float Stem	Adjustable Differential	
	Minimum	Maximum ③
6"	1"	4"
12"	1 1/2"	7 1/2"
18"	2 1/2"	11"
26"	3 1/2"	15 1/2"

② All models factory set with minimum differential unless otherwise specified.

③ Length of mounting nozzle on tank limits maximum differential. Application details in Bulletin 44 320.

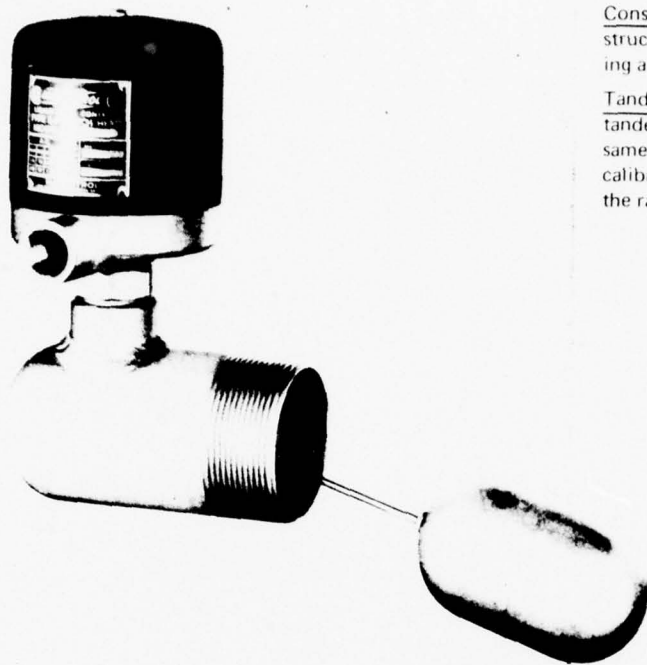

### MODEL TF-62

Fabricated Steel Body, 3" NPT Mounting Connection

The Model TF 62 with steel body is universally used in the process industries for level alarm and control functions such as scrubber level control on natural gas compressors and other like applications. The steel body is ruggedly built to withstand high pressure and temperature conditions and a variety of floats is available for a wide range of specific gravity ratings.

#### SPECIFICATIONS

**Switch Mechanism** . . . One Type S-1 mercury switch mechanism with SPST contacts is standard. Page 7 details optionally available switches.

**Switch Enclosure** . . . NEMA 1 is standard; others optionally available.

**Body** . . . The body is made up of a seamless carbon steel forging with 3" NPT male pipe thread mounting.

**Float and Trim** . . . A 3" dia. x 5" long column shaped Type 304 S.S. float is used with Type 304 S.S. trim as standard. A 400 series S.S. magnetic sleeve is standard. Optional floats are listed in the table at right — trim material options are listed below.

#### PRESSURE-TEMPERATURE RATINGS

The specified float will determine maximum pressure-temperature rating.

#### OPTIONAL FEATURES

**Switches** . . . SPDT mercury switches as well as dry contact types and pneumatic pilot switches are available. Page 7 details the most popular switch options.

**Switch Enclosures** . . . Standard options include splash proof, moisture proof and explosion proof types. Special designs are available to meet virtually any NEMA designation.

**Construction Materials** . . . Complete float and trim construction of Type 304 or Type 316 S.S. is available including a stainless steel sheathed magnetic sleeve.

**Tandem Operation** . . . The Model TF 62 is available for tandem operation (two switch mechanisms) providing the same functions as two single units, and can be factory calibrated to give individual switching actions throughout the range of float travel.

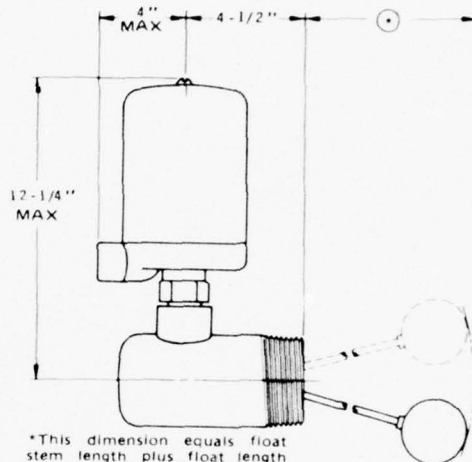

\*This dimension equals float stem length plus float length minus 2-3/4\".

#### FLOAT RATINGS SPECIFIC GRAVITY AND PRESSURE

Material	Float Size (inches)	Minimum Specific Gravity				Pressure Rating	
		Length of Float Stem				At 100°F	Maximum
		6"	12"	18"	26"		
Stainless Steel Type 304/316	2"	.80	.80	.90	.90	350	200@750°F
	2½x4	.50	.50	.55	.60	100	60@750°F
	3	.55	.55	.60	.65	250	150@750°F
	3x5	.65	.65	.70	.70	500	300@750°F
	3½ ①	.50	.50	.55	.55	400	225@750°F

① Can be used only where float can be attached from inside of tank. Float cannot pass through 3" NPT opening.

#### BODY PRESSURE RATING

Body Material	Pressure Rating PSI	
	At 100°F	Maximum
Carbon Steel	1200	680 @ 750°F

#### LEVEL DIFFERENTIALS ②

Length Of Float Stem	Adjustable Differential	
	Minimum	Maximum ③
6"	1½"	4½"
12"	2"	8½"
18"	2½"	11½"
26"	3½"	16½"

② All models factory set with minimum differential unless otherwise specified.

③ Length of mounting nozzle on tank limits maximum differential. Application details in Bulletin 44 320.

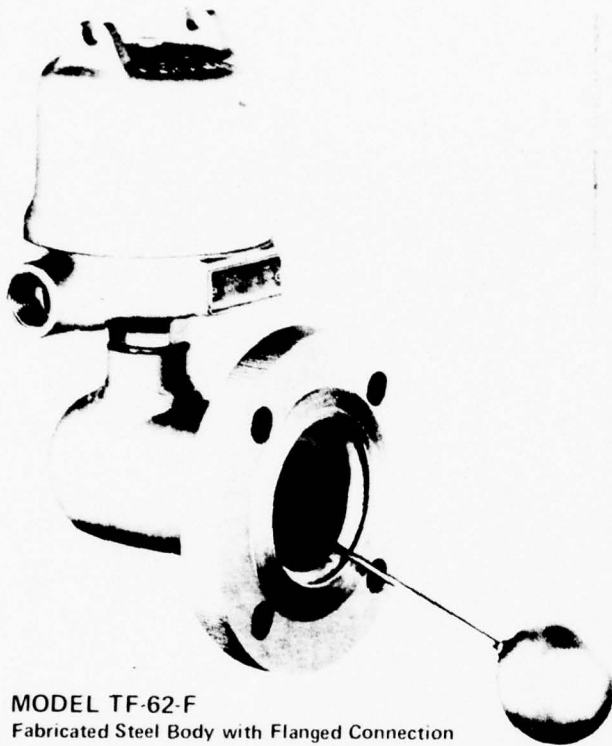

**MODEL TF-62-F**  
Fabricated Steel Body with Flanged Connection

The Model TF 62 F utilizes the same general construction as the TF 62 with a forged steel flange added for vessel connection. The standard flange is a 3" 150 lb. USAS raised face forged steel unit. Flanges of larger pipe sizes and higher pressure class ratings are optionally available.

**SPECIFICATION**

**Switch Mechanism** . . . One Type S-1 mercury switch mechanism with SPST contacts is standard. Page 7 details optionally available switches.

**Switch Enclosure** . . . NEMA 1 is standard; others optionally available.

**Body** . . . The body is made up of a seamless carbon steel forging to which the mounting flange is welded.

**Float and Trim** . . . A 2½" diameter Type 304 S.S. float is used with Type 304 S.S. trim as standard. A 400 series S.S. magnetic sleeve is standard. Optional floats are listed in the table at right – trim material options are listed below.

**PRESSURE TEMPERATURE RATINGS**

Float size and specified body flange both affect pressure-temperature rating as indicated in the tables at right. The body forging (less flange) is rated 1200 psi @ 100°F, 680 psi @ 750°F.

**OPTIONAL FEATURES**

**Switches** . . . SPDT mercury switches as well as dry contact types and pneumatic pilot switches are available. Page 7 details the most popular switch options.

**Switch Enclosures** . . . Standard options include splash proof, moisture proof and explosion proof types. Special designs are available to meet virtually any NEMA designation.

**Construction Materials** . . . Complete float and trim construction of Type 304 or Type 316 S.S. is available including a stainless steel sheathed magnetic sleeve.

**Tandem Operation** . . . The Model TF 62 F is available for tandem operation (two switch mechanisms) providing the same functions as two single units, and can be factory calibrated to give individual switching actions throughout the range of float travel.

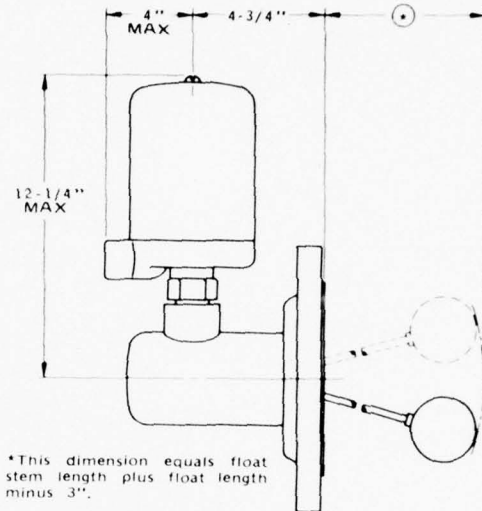

**FLOAT RATINGS**  
**SPECIFIC GRAVITY AND PRESSURE**

Material	Float Size (inches)	Minimum Specific Gravity				Pressure Rating PSI ①	
		Length of Float Stem				At 100°F	Maximum
		6"	12"	18"	26"		
Stainless Steel Type 304/316	2½"	.80	.80	.90	.90	350	200@750°F
	2½x4"	.50	.50	.55	.60	100	60@750°F
	3" ②	.55	.55	.60	.65	250	150@750°F
	3x5" ②	.65	.65	.70	.70	500	300@750°F
	3½" ③	.50	.50	.55	.55	400	225@750°F

- ① Body pressure rating must also be considered. See table below. Lowest rating determines maximum pressure-temperature limit.
- ② To pass float, tank nozzle bore diameter must not be less than 3" schedule 40 pipe size.
- ③ Recommended for use with 4" or larger tank nozzles or where float can be attached from inside of tank when 3" tank nozzle is used.

**BODY PRESSURE RATINGS (PSI)**

USAS Flange Designation	Pressure Rating PSI	
	At 100°F	Maximum
150 Lb.	275	100 @ 750°F
300 Lb.	720	425 @ 750°F
400 Lb.	960	575 @ 750°F
600 Lb.	1200	680 @ 750°F

**LEVEL DIFFERENTIALS ①**

Length Of Float Stem	Adjustable Differential	
	Minimum	Maximum ②
8"	1¼"	3½"
12"	1¾"	5¾"
18"	2¾"	7½"
26"	3¾"	10¼"

- ① All models factory set with minimum differential unless otherwise specified.
- ② Length of mounting nozzle on tank limits maximum differential. Application details in Bulletin 44 320.

## MAGNETROL SWITCH MECHANISMS FOR STANDARD AND SPECIAL APPLICATIONS

Mercury switches are used as standard in Magnetrol side mounted level controls because of their outstanding features — like high load carrying capacity, hermetically sealed contacts and convenient visual inspection. Other types of switch mechanisms including dry contact and pneumatic switches are available for special applications. Several of the most popular Magnetrol switch mechanisms are described here.

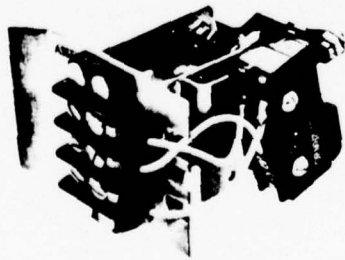
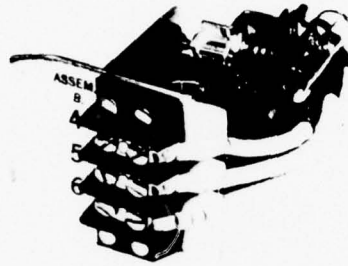

### TYPE S-1 MERCURY SWITCH

The Type S-1 switch mechanism is standard in most Magnetrol side mounted controls. It is completely self-contained with numbered terminal strip, removable mercury switch and actuation magnet. SPST or SPDT mercury switches are rated up to 13 amp service. A specially developed vibration resistant mercury switch mechanism is also available. Details and ratings in bulletin 42-320.

### TYPE DPS-1 MERCURY SWITCH

The Type DPS-1 mechanism uses two mercury switches actuated by the same magnet to obtain double pole operation. DPST or DPDT contacts are available; a high temperature porcelain terminal block is standard. A typical application would include the control of two different voltage circuits such as 110 volts on one circuit with 220 volts on the other. For tandem applications two Type DPS-1 switch mechanisms will fit inside a standard length switch housing. Request bulletin 42-321 for complete details.

### DRY CONTACT TYPE SWITCHES

Dry contact switches — like the Type S-1M illustrated — are used in place of mercury switches in applications where mercury may present a contamination problem such as in photographic film plants and nuclear installations. They are also used where excessive vibration is present or in ship board installations where the roll of the vessel could cause false mercury switch actuation. Bulletins 42-330 and 42-331 contain complete information.

### PNEUMATIC PILOT SWITCHES

Pneumatic switches can be applied to Magnetrol side mounted controls for special applications — such as hazardous or potentially explosive atmospheres, in refineries or chemical plants. The pneumatic switch would be used as a pilot device to actuate a pressure switch located in a non hazardous location or to actuate a pneumatically operated valve. The Type J-1 pilot, as illustrated, is available for single level stage applications. A dual pilot version is also available for tandem applications. Details and ratings in bulletins 42-340 and 42-341.

## SPECIAL APPLICATIONS

Side mounted Magnetrol level controls are available with special construction to make them suitable for the most difficult applications. Typical examples of Magnetrol's custom application engineering capability are given here.

### LOW SPECIFIC GRAVITY SERVICE

All side mounted Magnetrol instruments are available with specially counterweighted floats for applications involving liquids with very low specific gravity ratings.

### INTERFACE DETECTION

Specially calibrated side mounting instruments are available for applications requiring the detection of the interface or cleavage between two dissimilar liquids — such as gasoline over water.

### CORROSIVE SERVICE

Side mounted Magnetrols are available with special float and trim materials, such as Monel and other alloys, to combat corrosive liquid applications.

## SUGGESTED SPECIFICATION

Furnish and install a Model \_\_\_\_\_ side mounted Magnetrol liquid level control suitable for use with a \_\_\_\_\_ specific gravity liquid and having a pressure rating of \_\_\_\_\_ psi @ \_\_\_\_\_ °F. The instrument shall have (mercury) (dry contact) (pneumatic) switching action accomplished by direct magnetic operation and shall employ permanent type alternately engaged ALNICO metallic alloy magnet switch actuators located exterior to the liquid process. The unit shall be equipped with (single) (dual) switch mechanism(s) to provide the following switching functions:

---

## HOW TO ORDER

To assure selection of the most appropriate Magnetrol liquid level control to meet application conditions, please provide the following information when ordering.

1. Name or Type of Liquid
2. Working and Maximum Pressure and Temperature
3. Specific Gravity of Liquid
4. Desired Switch Action
5. Style of Switch Housing Required
6. Special Materials or Optional Features Desired

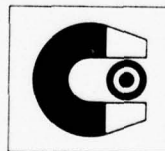

 **MAGNETROL**  
division of Schaub Engineering Co  
5300 BELMONT ROAD — DOWNERS GROVE, ILLINOIS 60515 — 312 969 4000



# MAGNETROL

division of Schaub Engineering Co.

5300 BELMONT ROAD → DOWNERS GROVE, ILLINOIS 60515 → 312 | 969-4000

## SWITCH MECHANISMS AND HOUSINGS

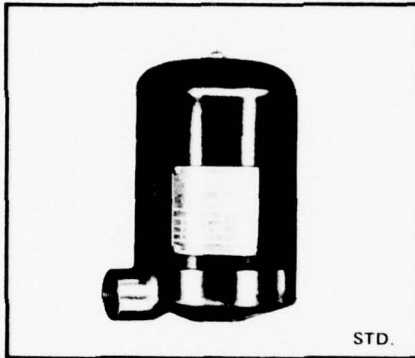

STD.

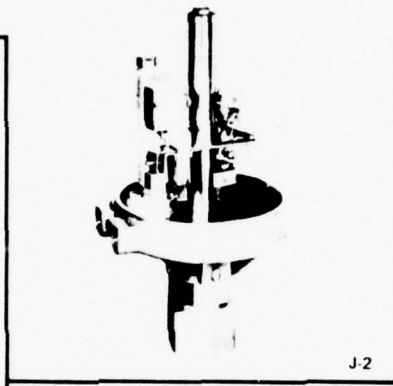

J-2



E.P.

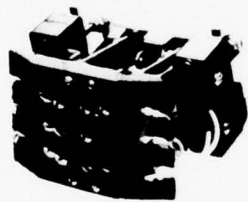

DPS-1M

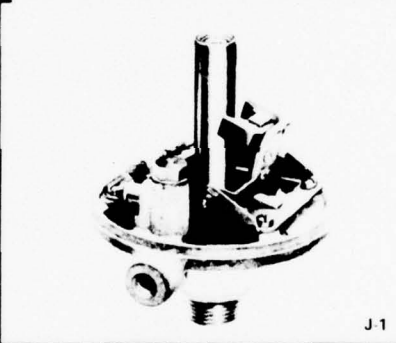

J-1



SPDPS-1

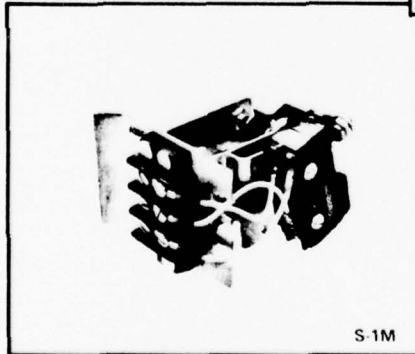

S-1M

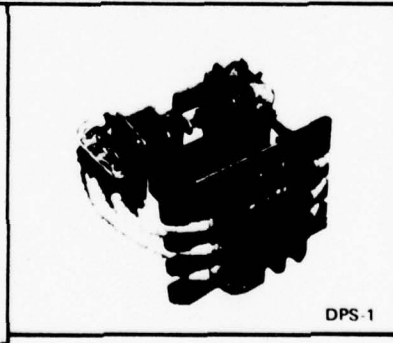

DPS-1

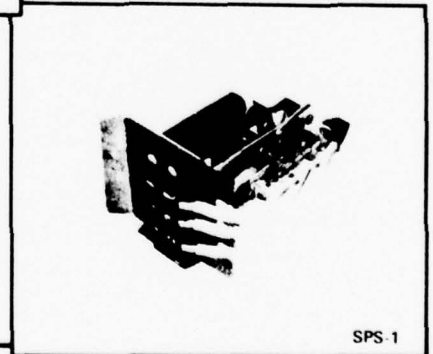

SPS-1



M-1

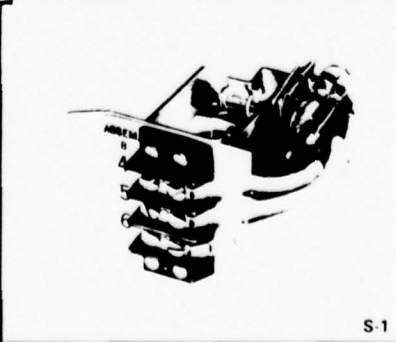

S-1

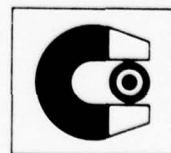

BULLETIN NO. 42-110



## MAGNETROL SWITCH MECHANISMS AND HOUSINGS FOR STANDARD AND SPECIAL APPLICATIONS . . . . .

Mercury switches are used as standard in most Magnetrol liquid level controls and flow switches because of their outstanding features — like high load carrying capacity, hermetically sealed contacts and convenient visual inspection. Other types of switch mechanisms including dry contact and pneumatic pilot switches are available for most applications. All of the most popular Magnetrol switch mechanisms are described herein.

Switch housing designs are available to meet virtually any NEMA specification including splash proof, moisture proof and explosion-vapor proof.

### APPLICATION GUIDE

MERCURY SWITCHES		
Model	Description	Page
S-1	General purpose for liquids up to 750°F. Mercury to mercury contacts.	23
DPS-1		
SPS-1	Anti-vibration service, for liquids up to 750°F. Mercury to mercury contacts.	45
SPDPS-1		
DRY CONTACT SWITCHES		
S-1M	Dry contact type mechanisms for liquids up to 450°F. Inter-changeable with standard S-1 mechanisms where mercury switches prohibited.	6
DPS-1M		
M-1	Dry contact type mechanisms for liquids up to 450°F. For unsteady installations such as shipboard service or applications with severe vibration.	7
M-4		
PNEUMATIC SWITCHES		
J-1	Bleed type pneumatic switch for liquids up to 450° F. 40 psi supply standard.	8
J-2	Non-bleed type pneumatic switch with vibration resistant construction. Model available for liquids over 450°F. 40 psi supply standard.	9
SWITCH HOUSINGS		
Standard Type	NEMA 1 thru 12; standard, splash proof, moisture proof and explosion-vapor proof.	10
Optional	Transparent, explosion proof; w/double tap conduit conn. and Class 1, group "B".	11
SWITCH WIRING		
ALL	Typical Wiring Procedures	12
	Terminal Connections (Wiring Diagrams)	

## MERCURY SWITCHES

### DESIGN ADVANTAGES

Mercury switches offer many useful advantages including these most important features:

**LONG LIFE** . . . practically no limit to the number of operating cycles.

**NO BURNING OF CONTACT POINTS** . . . an atmosphere of inert gas inside the switch helps to quench arcs.

**HIGH DC RATINGS** . . . mercury switches are rated significantly higher for Direct Current service than most other types of switches.

**EASY VISUAL INSPECTION** . . . the glass tube permits positive inspection of the switch at a glance.

### TYPE S-1 MERCURY SWITCH MECHANISM

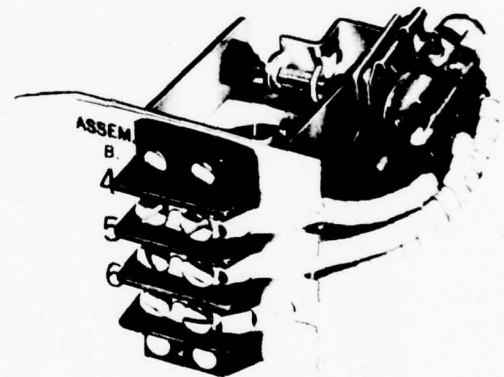

### DESCRIPTION

Most off-on type Magnetrol liquid level controls utilize the type S-1 switch mechanism as standard. It is unitary in design and employs a pivoted, magnet actuated mercury switch, having either two wire SPST contacts or three wire SPDT contacts.

### APPLICATION

The type S-1 switch mechanism is designed for general purpose applications on liquids having temperatures ranging from -30°F. to 750°F. For temperatures up to 1000°F. special modifications are required such as the addition of cooling fins to the Magnetrol switch housing.

For multi-level stage switching applications up to three mechanisms can be positioned one above the other within a standard length Magnetrol switch housing. A special length housing is required to accommodate more than three type S-1 switch mechanisms.

### CONSTRUCTION

The temperature of the liquid to be controlled influences construction materials. For liquid temperatures up to 450°F., a molded phenolic terminal board and copper lead-in wires are used. A porcelain terminal board and nickel-clad copper wires are used for liquid temperatures over 450°F.

### SWITCH IDENTIFICATION CODE

The following codes are suffixed to the Magnetrol model number for switch identification.

CODE	FORM	FUNCTION
S11	SPST	MAKE ON LOW LEVEL
S12	SPST	MAKE ON HIGH LEVEL
S13	SPDT	SINGLE POLE DOUBLE THROW

**NOTE:** In side mounting controls the switching action is reversed (typical of Model TF-63). Code S11 will make on high level and Code S12 will make on low level.

### TYPE DPS-1 MERCURY SWITCH MECHANISM

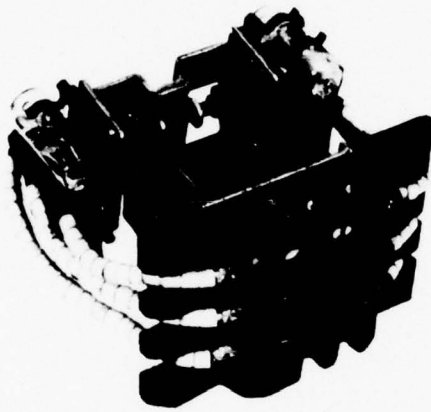

### DESCRIPTION

The type DPS-1 switch mechanism incorporates two electrically separate single pole mercury switches actuated at the same time by a single magnet assembly to provide double pole contact action. The type DPS-1 switch mechanism is designed to be directly interchangeable with the type S-1 switch mechanism used in most Magnetrol liquid level controls and flow switches.

### ELECTRICAL RATINGS FOR TYPE S-1 AND TYPE DPS-1 SWITCH MECHANISMS

LOAD	AC			DC	
	110 - 120 V ①	220 - 240 V ①	440 - 480 V ②	110 - 120 V ①	220 - 240 V ①
Motor Rating	½ HP	½ HP	½ HP	½ HP	½ HP
Full Load	9.8 A	4.9 A	2.5 A	5.2 A	2.6 A
Locked Rotor	58.8 A	29.4 A	15.0 A	52.0 A	26.0 A
Non-Inductive	10.0 A	6.5 A	3.7 A	10.0 A	5.0 A
Pilot Duty	360 VA	360 VA	360 VA	—	—

① Ratings given apply to Magnetrol instruments equipped with a single switch mechanism. Multiple switch mechanisms carry following ratings. (UL Guide)

#### TWO MECHANISMS

120 V, AC, 7 amp, ½ HP, 360 VA pilot duty.  
 240 V, AC, 6.5 amp, ½ HP, 360 VA pilot duty.  
 120 V, DC, 7 amp, ½ HP.  
 240 V, DC, 5 amp, ½ HP.

#### THREE MECHANISMS

120 V, AC, 5.5 amp, ½ HP, 360 VA pilot duty.  
 240 V, AC, 5.5 amp, ½ HP, 360 VA pilot duty.  
 120 V, DC, 5.5 amp, ½ HP.  
 240 V, DC, 5 amp, ½ HP.

② Requires Non UL Listing.

### APPLICATION

The type DPS-1 switch mechanism is used in applications requiring the switching of two circuits at the same time such as to break both sides of a control circuit. It is also used to carry two circuits of differing characteristics such as both AC and DC current of two different voltages. The mechanism is suitable for applications involving liquid temperatures from -30°F. to 750°F. For temperatures up to 1000°F. special modifications are required such as the addition of cooling fins to the Magnetrol switch housing. Consult the area Magnetrol representative for special recommendations.

For multi-level stage switching applications two type DPS-1 mechanisms can be positioned one above the other within a standard length Magnetrol switch housing. A combination of one type DPS-1 and one type S-1 mechanism can also be accommodated in a standard length cover. A special length housing is required to accommodate more than two switch mechanisms.

### CONSTRUCTION

The type DPS-1 switch mechanism utilizes a molded porcelain terminal board and nickel-clad copper switch lead-in wires for all liquid temperature applications.

### SWITCH IDENTIFICATION CODE

The following code designations are suffixed to the Magnetrol model number for switch identification.

CODE	FORM	FUNCTION
S1D1	DPST	2 circuits, make on low level
S1D2	DPST	2 circuits, make on high level
S1D4	DPDT	Double pole double throw
S1D5	DPST	1 circuit normally open, 1 circuit normally closed



## SPECIAL PURPOSE MERCURY SWITCHES

### DESIGN ADVANTAGES

Mercury switches offer many useful advantages including these most important features:

**LONG LIFE** . . . practically no limit to the number of operating cycles.

**NO BURNING OF CONTACT POINTS** . . . an atmosphere of inert gas inside the switch helps to quench arcs.

**EASY VISUAL INSPECTION** . . . the glass tube permits positive inspection of the switch at a glance.

**TYPE SPS-1 VIBRATION RESISTANT  
MERCURY SWITCH MECHANISM**

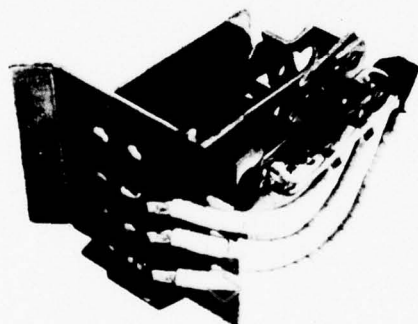

### DESCRIPTION

These special purpose switch mechanisms have been developed for use in vibration service applications associated with compressor scrubbers in the petroleum and chemical process industries. The type SPS-1 unit is of single pole design while the type SPDPS-1 mechanism is equipped with two mercury switches for double pole operation. Each mechanism is designed to be directly interchangeable with the standard type S-1 mechanism used in most Magnetrol liquid level controls and flow switches.

### APPLICATION

The mercury switches employed in the type SPS-1 and SPDPS-1 mechanisms differ from the standard type S-1 mercury switches in that electrical contact is established between a mercury pool and an electrode. The electrode is designed to dampen the travel of the mercury, largely eliminating vibration caused false switching acutations. For compressor drive engine magneto shorting applications, special purpose switch mechanisms are available designed to close up to four circuits to a common ground. These mechanisms are suitable for applications involving liquid temperatures from -30°F. to 750°F. (up to 1000°F. with special control modifications).

For multi-level stage switching applications up to three single pole type SPS-1 mechanisms can be positioned one above the other within a standard length Magnetrol switch housing. Two double pole mechanisms or a combination of one double pole and one single pole mechanism can also be accommodated in a standard housing. A special length housing is required to accommodate any additional switch mechanisms.

### CONSTRUCTION

Type of Mechanism	Maximum Liquid Temperature	Switch Lead Wire	Lead Wire Insulation	Terminal Board
SPS-1	450°F	Copper	Silicone Rubber	Molded Phenolic
	750°F	Nickel Clad Copper	Porcelain Beads	Molded Porcelain
SPDPS-1	450°F	Copper	Silicone Rubber	Molded Porcelain
	750°F	Nickel Clad Copper	Porcelain Beads	



**TYPE SPDPS-1 VIBRATION RESISTANT  
MERCURY SWITCH MECHANISM**

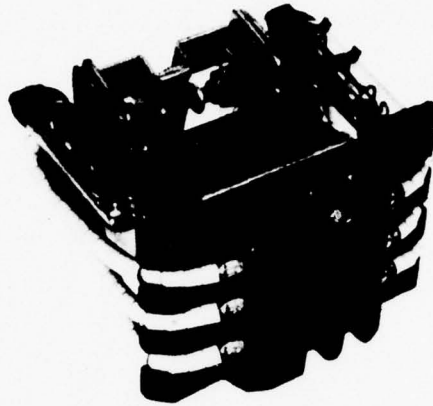

**SWITCH IDENTIFICATION CODE**

The following code designations are suffixed to the Magnetrol model number for switch identification:

TYPE	CODE	FORM	FUNCTION
SPS-1	S15	SPST	Two Circuits to Common Ground on Low Level
	S16	SPST	Two Circuits to Common Ground on High Level
	S17	SPDT	Single Pole Double Throw
	S18	SPST	Make on Low Level
	S19	SPST	Make on High Level
SPDPS-1	S1D6	DPST	Two SPST, 4 Circuits to Common Ground on Low Level
	S1D7	DPST	1 SPST, 2 Circuits to Common Ground on Low Level 1 SPST, 2 Circuits to Common Ground on High Level
	S1D10	SPDT & SPST	SPDT Plus SPST, 2 Circuits to Common Ground on Low Level
	S1D11	DPST	4 Circuits to Common Ground on High Level
	S1D14	SPDT & SPST	SPDT Plus 2 Circuits to Common Ground on High Level
	S1D20	DPDT	Two SPDT Switches

NOTE: In side mounting controls the switching action of the SPST and DPST switches are reversed (typical of Model TF-62 and TF-63).

**ELECTRICAL RATINGS FOR TYPE SPS-1 AND TYPE SPDPS-1 SWITCH MECHANISMS**

LOAD	AC			DC	
	115 V	230 V	440 V	115 V	230 V
Full Load Motor Rating	HP	HP	—	HP	HP
Continuous Inductive Current	3.8 A	1.9 A	—	2.4 A	1.2 A
Locked Rotor Current	22.8 A	11.4 A	—	24 A	12 A
Non-Inductive Current	4 A	2 A	1 A	4 A	2 A

## DRY CONTACT SWITCHES

### TYPE S-1M and DPS-1M DRY CONTACT SWITCH MECHANISMS



S-1M



DPS-1M

#### DESCRIPTION

The type S-1M and DPS-1M switch mechanisms utilize magnet actuated dry contact switches and are designed to be interchangeable with the type S-1 mercury switch mechanism used in most Magnetrol liquid level controls and flow switches. The type S-1M mechanism employs a single SPDT dry contact switch while the type DPS-1M unit incorporates two electrically independent SPDT switches actuated by a single magnet to provide DPDT contact action.

#### APPLICATION

The types S-1M and DPS-1M switches are normally specified in lieu of standard mercury switches for applications where mercury is undesirable or prohibited — such as in photographic film manufacturing or nuclear power installations. These switch mechanisms are directly interchangeable with the type S-1 mercury switch mechanism eliminating the need for special calibrations or modified internal operating components.

#### ELECTRICAL RATINGS AND SWITCH IDENTIFICATION CODES FOR TYPE S-1M AND TYPE DPS-1M SWITCH MECHANISMS

The maximum temperature of the liquid to be controlled influences the available electrical ratings. The table below lists ratings for two liquid temperature ranges — ambient to 250°F. to 450°F.

Maximum Liquid Temperature	Switch Description	Switch Identification Code	Load	Volts AC			Volts DC	
				120	240	480	120	240
250°F	Standard SPDT Contacts	S1M3	Non-Inductive Amp	15	15	15	0.40	0.20
			Inductive Amp	3.8	2.9	—	0.05	0.03
	Standard DPDT Contacts	S1MD4	Horsepower	1/8	1/4	—	—	—
			Special SPDT Contacts For DC Service	S1M3DC	Non-Inductive Amp	10	—	—
	Special DPDT Contacts For DC Service	S1MD4DC	Inductive Amp	3.80	—	—	2.2	—
			Horsepower	1/8	—	—	1/8	—
450°F	Standard SPDT Contacts	S1M3H	Non-Inductive Amp	5	5	5	0.40	0.20
			Inductive Amp	—	—	—	0.05	0.03
	Standard DPDT Contacts	S1MD4H	Horsepower	1/10	1/6	—	—	—

For multi-level stage switching applications, up to three single pole type S-1M mechanisms can be positioned one above the other within a standard length Magnetrol switch housing. Two double pole type DPS-1M or a combination of one double pole and one single pole mechanism can also be accommodated in the standard housing. A special length housing is required to accommodate any additional switch mechanisms.

#### TEMPERATURE LIMITS

Standard Magnetrol models equipped with type S-1M and type DPS-1M switch mechanisms are limited to applications where the temperature of the liquid to be controlled does not exceed 450°F. For higher temperatures special modifications are required such as the addition of cooling fins to the Magnetrol switch housing. Consult the area Magnetrol representative for special recommendation.

#### HERMETICALLY-SEALED DRY CONTACT SWITCH MECHANISMS

##### DESCRIPTION

The hermetically-sealed dry contact switch mechanisms are adaptations of (and interchangeable with) the standard S-1M and DPS-1M mechanisms, fitted with miniature, metal cased snap switches which have been hermetically-sealed in accordance with military standard MIL-S-8805, enclosure design symbol 5.

These mechanisms are specified for dry contact switching applications involving liquid temperatures up to 750°F. where damp or humid atmospheres may be encountered. The interior of the metal cased switch is filled with an inert gas to help quench arcs.

Switch Description	Switch Identification Code	Load	VAC		VDC
			28	115	28
SPDT	S-1HM	Resistive Amp	2	1/4	4
DPDT	S-1DHM	Inductive Amp	2	1/4	2

## TYPE M-1 and M-4 DRY CONTACT SWITCH MECHANISMS

### DESIGN ADVANTAGES

The type M-1 and M-4 switch mechanisms solve application problems unapproachable with mercury switches and offer the following useful features:

**VIBRATION RESISTANCE** . . . the dual magnet switching principle is ideal for use on excessive vibration applications.

**INSENSITIVE TO MOUNTING POSITION** . . . the type M-1 or M-4 switch mechanisms assure positive switch operation in unsteady installations such as shipboard installations, or where the Magnetrol instrument must be mounted at an angling deviating from the vertical.

**HIGH DC RATINGS** . . . special SPDT switches are available for high DC ratings.

### DESCRIPTION

The type M-1 and M-4 dry contact switches offer a high degree of vibration resistance. Differing from the standard mercury switch mechanism used in most Magnetrol instruments, they employ dual magnets to actuate the switch. The magnets are secured to a pivoted switch actuating rocker arm assembly. One magnet actuates the switch at high level, the second actuates the switch at low level, thus one magnet is always holding the switch in position.

### APPLICATION

The type "M" switch mechanisms are ideally used in applications involving excessive vibration or in marine installations where the motion of the ship or vessel would interfere with the normal operation of mercury type switches. The type "M" switches can be adapted to most Magnetrol models which employ the standard type S-1 mercury switch mechanism.

### TYPE M-1 MECHANISM

This mechanism is designed for single level stage switching applications and is available with a single SPDT switch or two SPDT switches arranged for DPDT operation.

### TYPE M-4 MECHANISM

The type M-4 switch is designed for two level stage switching applications. The mechanism incorporates two SPDT snap switches, each actuated by a separate magnet assembly for independent switch operating levels. The type M-4 switch mechanism is ideally suited to narrow level range applications where approximately one inch of level travel is sufficient to sequentially actuate the two switches. (Exact level travel required is determined by application conditions.

### TEMPERATURE LIMITS

Standard Magnetrol models equipped with type M-1 and type M-4 switch mechanisms are limited to applications where the temperature of the liquid to be controlled does not exceed 450°F. For higher temperatures special modifications are required such as the addition of cooling fins to the Magnetrol switch housing. Consult the area Magnetrol representative for special recommendations.

### TYPE M-1 DRY CONTACT SWITCH MECHANISM

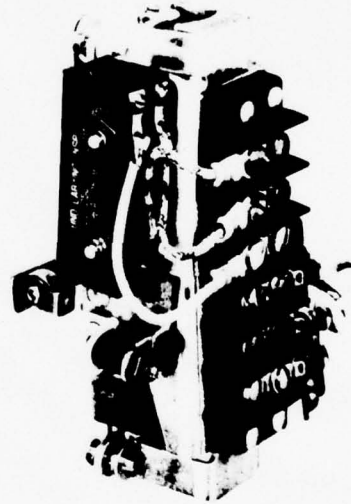

## ELECTRICAL RATINGS AND SWITCH IDENTIFICATION CODES FOR TYPE M-1 AND TYPE M-4 SWITCH MECHANISMS

The maximum temperature of the liquid to be controlled influences the available electrical ratings. The table below lists ratings for two liquid temperature ranges — ambient to 250°F. and 251°F. to 450°F.

Maximum Liquid Temperature	Switch Description	Switch Identification Code	Load	Volts AC			Volts DC
				120	240	480	120
250°F	Standard SPDT Contacts	M13	Non-Inductive Amp	15	15	15	0.40
			Inductive Amp	3.8	2.9	—	—
	Standard DPDT Contacts	M14	Horsepower	1/8	1/4	—	—
			Non-Inductive Amp	10	—	—	10
	Special SPDT Contacts For DC Service	M13DC	Inductive Amp	3.80	—	—	2.2
			Horsepower	1/8	—	—	1/8
450°F	Standard SPDT	M13H	Non-Inductive Amp	5	5	5	0.40
			Inductive Amp	—	—	—	—
	Standard DPDT Contacts	M14H	Horsepower	1/10	1/6	—	—

## PNEUMATIC SWITCHES

### TYPE J-1 PNEUMATIC PILOT SWITCH

#### DESIGN ADVANTAGES

Like all Magnetrol switches, the type J-1 pilot mechanism offers the user many unique and useful features — several of the most important are listed here.

**ADJUSTABLE** . . . the pilot nozzle can be field set to open or close at either high or low liquid level.

**CORROSION RESISTANT** . . . all operating components are of stainless steel and are suitable for use with well head gas as well as regular instrument air.

**ADAPTABLE** . . . the type J-1 pilot can be furnished as an optional switch mechanism on most all Magnetrol liquid level controls and flow switches.

**SUITABLE FOR TANDEM OPERATION** . . . a dual pilot type J-1 mechanism is available for two level stage applications.

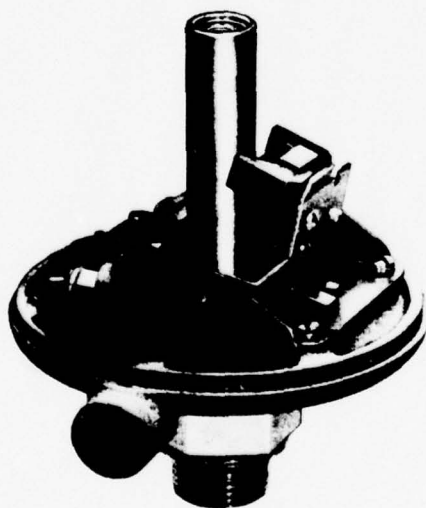

#### DESCRIPTION

The Magnetrol type J-1 pilot mechanism is the simplest form of two position pneumatic control. It incorporates a single pipe bleed nozzle that is opened and closed by a flapper assembly magnetically coupled to a liquid level or flow sensing device.

The type J-1 pneumatic pilot is interchangeable with the standard type S-1 electric switch mechanism used in most Magnetrol liquid level controls and flow switches. A dual pilot type J-1 mechanism is available for two level stage switching applications.

#### APPLICATION

The J-1 pilot can be used to position a diaphragm actuated control valve by acting as a bleed gate in the air supply line to the valve diaphragm. When the J-1 pilot nozzle opens it bleeds air faster than can be supplied through a suitable restriction fitting located in the supply line, thus unloading the valve diaphragm. The J-1 pilot is also used in explosive or hazardous atmospheres to pneumatically operate a remote electrical device such as a pressure switch located in a non-hazardous area.

#### CONSTRUCTION

The standard type J-1 mechanism with silicone rubber coated flapper is suitable for applications where controlled liquid temperatures do not exceed 400°F. A spring loaded ball valve assembly replaces the standard flapper-nozzle for temperatures over 400°F.

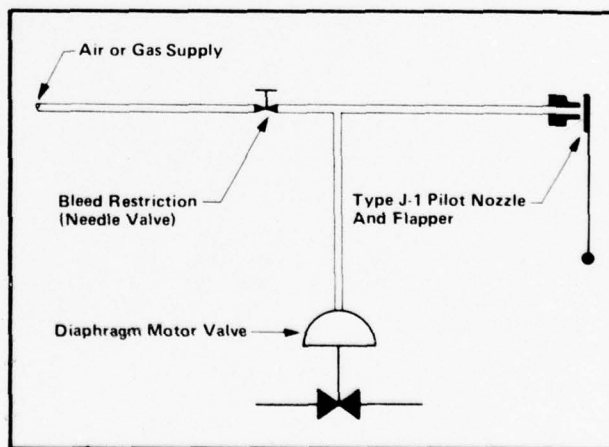

#### BLEED RATES

Bleed rates at several supply pressures are given below for the two standard nozzle sizes. The standard 1/16" diameter nozzle is designed to seal against 100 PSIG supply pressure. The alternate 3/32" diameter nozzle is designed to seal against 60 PSIG supply pressure.

NOZZLE DIAMETER	SWITCH IDENTIFICATION CODE	AIR FLOW, SCFM AT VARIOUS SUPPLY PRESSURES									
		10 PSI	20	30	40	50	60	70	80	90	100
1/16"	J-16	.80	1.50	2.10	2.60	3.10	3.50	4.00	4.50	5.00	5.60
3/32"	J-19	1.20	2.20	3.10	4.00	4.70	5.40	-	-	-	-

## TYPE J-2 PNEUMATIC PILOT SWITCH

### DESIGN ADVANTAGES

The type J-2 pilot, like all Magnetrol switch mechanisms, is designed with many unique and useful features — several of the most important are listed here.

**NON-BLEED** . . . the type J-2 pilot conserves instrument air (or operating gas). With the supply port closed, only the entrapped downstream air between the valve and the pneumatic actuator exhausts to the atmosphere.

**VIBRATION RESISTANT** . . . the dual magnet design provides positive valve positioning under vibration conditions.

**FIELD ADJUSTABLE** . . . the ball valve assembly can be field adjusted to open or close the supply port at either high or low operating level.

**FAST OPERATION** . . . no consideration need be given to nozzle sizing and "bleed rates". A single size ball valve is used for all applications.

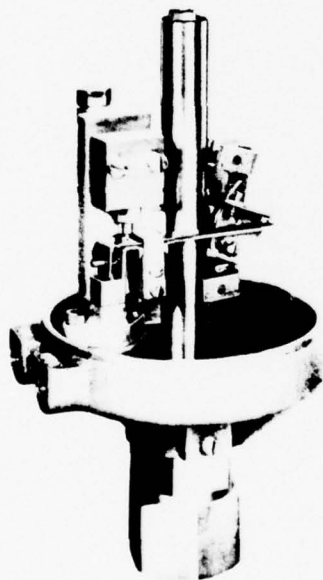

### DESCRIPTION

The type J-2 mechanism is a snap acting non-bleed type pneumatic switch incorporating a magnetically operated three way ball valve assembly. The ball valve — positioned by a magnet assembly — opens a supply port allowing air (or operating gas) to flow to the operated equipment, such as a diaphragm actuated control valve. As the magnet assembly pivots in response to a change in attraction sleeve position — as when attached to a float following a rising liquid level — the ball valve closes the supply port and simultaneously opens the exhaust port allowing the pressure in the operated equipment to bleed to atmosphere.

The J-2 pilot mechanism is available as an optional switch mechanism on most Magnetrol liquid level controls designed for single level stage applications.

### APPLICATION

The type J-2 mechanism is designed to operate under the vibration and corrosive conditions associated with petroleum industry applications such as scrubber level control on natural gas compressors. The ball valve assembly is constructed of type 316 stainless steel for good corrosion resistance when operating with well head gas containing varying amounts of hydrogen sulfide.

The type J-2 mechanism can be used to operate diaphragm actuated valves to control the liquid level in tanks or vessels. It is also used in conjunction with proportional pneumatic level controls as a positive overriding safety device to prevent tanks from overflowing, or running dry.

### CONSTRUCTION

The type J-2 mechanism utilizes stainless steel and aluminum construction throughout with high strength ALNICO magnets. The standard mechanism is suitable for applications with controlled liquid temperatures up to 450°F. For higher temperature applications special "O" ring seals are used.

### PERFORMANCE

The tables below represent typical performance of the standard type J-2 pilot mechanism.

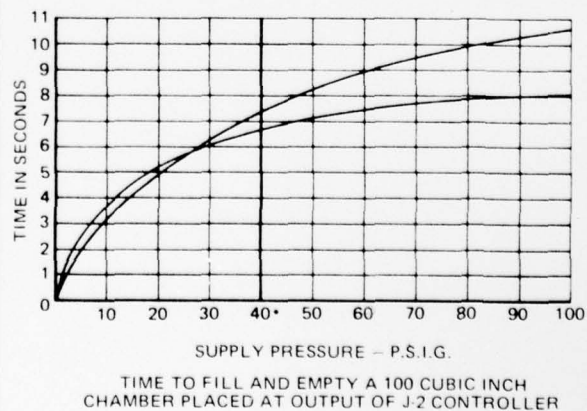
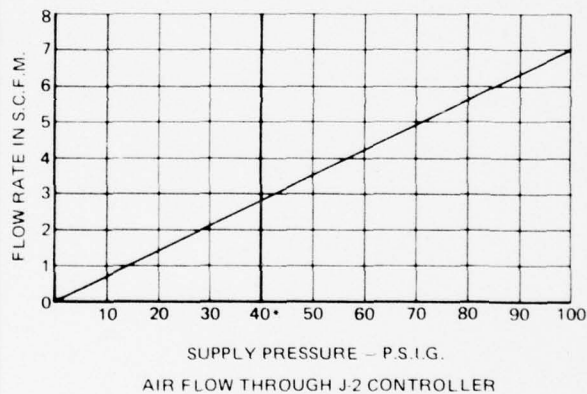

\* 40 PSIG MAXIMUM SUPPLY PRESSURE TO STANDARD J-2 PNEUMATIC CONTROLLER. SPECIAL CONSTRUCTION AVAILABLE FOR J-2 MECHANISM TO OPERATE AGAINST SUPPLY PRESSURES UP TO A 100 PSIG MAXIMUM.

# STANDARD SWITCH HOUSINGS

## TYPICAL MAGNETROL SWITCH HOUSINGS (Type S-1 Switch Head)

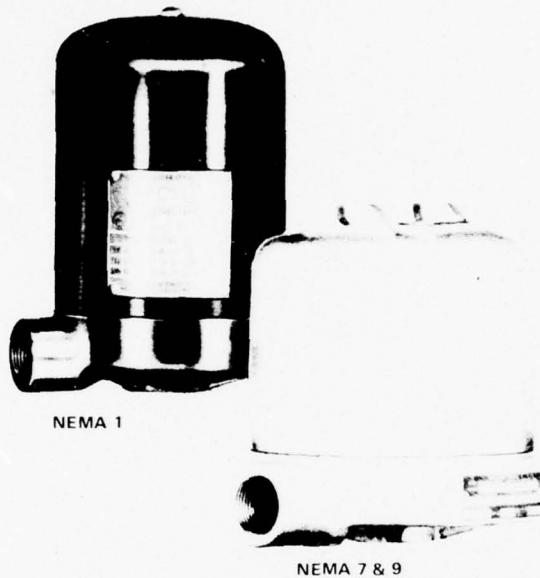

A variety of switch housings are available for application to most Magnetrol controls. Alternates to the general purpose enclosure include splash proof, moisture proof and explosion proof designs. A selection guide table to the application of the various Magnetrol housings is given below.

### CONSTRUCTION DETAILS

The standard, splash proof and moisture proof enclosures employ a deep drawn steel housing cover fitted to an aluminum die cast housing base. The housing base is furnished with a single 3/4" NPT conduit connection which is

rotatable through 360° for ease in wiring. The splash proof and moisture proof versions are fitted with appropriate seals to exclude undesirable atmosphere.

The explosion proof enclosure consists of a heavy-duty cast iron housing cover threaded into a cast iron housing base. The assembly includes gaskets to provide vapor proof construction. The housing base is equipped with a single 1" NPT conduit connection which is rotatable 360° for ease in wiring.

### STANDARD HOUSING DIMENSIONS

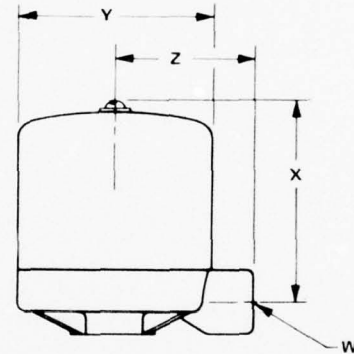

TYPE OF COVER	W	X	Y	Z
Standard Short	3/4" NPT	5 1/16"	4 3/8"	3 1/4"
Standard Tall	3/4" NPT	7 1/16"	4 3/8"	3 1/4"
Explosion Proof Short	1" NPT	5 3/8"	5 3/8"	4"
Explosion Proof Tall	1" NPT	7 3/8"	5 3/8"	4"

NOTE: Dimensions given are subject to change without notice.

### SELECTION GUIDE TO MAGNETROL SWITCH HOUSINGS

NEMA ①		Application	Recommended Magnetrol Housing
Type	Description		
1	General Purpose	Indoor applications, not exposed to unusual service conditions.	"Standard"
2	Drip Tight	Designed to exclude falling moisture or dirt. Suitable for use in cooling rooms and laundries.	Splash Proof
3	Weather Resistant	Suitable for use outdoors to provide protection against specified weather hazards.	Moisture Proof ②
3R	Rain Tight	Designed to exclude beating rain. Suitable for general outdoor applications.	Moisture Proof ②
4	Water Tight	No leakage of water into housing when subjected to a 65 GPM stream of water from a 1" hose nozzle, at a minimum distance of ten feet.	Moisture Proof ②
5	Dust Tight	A gasketed enclosure designed to exclude dust. Suitable for non-hazardous locations.	Moisture Proof ②
6	Submersible	Suitable for submersion under water.	Consult Factory
7	Hazardous Locations	Indoor or outdoor applications where explosive or potentially explosive atmospheres may be present.	Explosion Proof
9			
12	Industrial Use	Enclosure designed to exclude dust, lint, fibers, oil or coolant seepage. Suitable for non-hazardous locations.	Moisture Proof ②

① National Electrical Manufacturers Association classifications.

② For use only in non hazardous location applications.

## OPTIONAL SWITCH HOUSINGS

### TRANSPARENT HOUSING COVER (Type S-1 Switch Head)

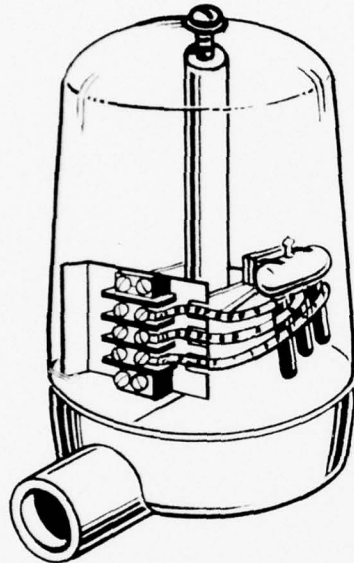

#### DESCRIPTION

The transparent housing cover is used interchangeably with the standard Magnetrol steel housing in applications where it is desirable to inspect the switch mechanism without need for cover removal. It also allows positive visual identification of switch position ("off" or "on").

#### CONSTRUCTION

The housing cover is molded from LEXAN — a higher performance polycarbonate resin manufactured by the General Electric Company. Lexan exhibits high impact strength, high heat resistance and is ultraviolet stabilized for excellent transparency retention.

#### TEMPERATURE RATINGS

The transparent housing cover is suitable for ambient temperatures between -40°F. and +230°F.

#### DIMENSIONS

The transparent cover is directly interchangeable with the NEMA 1 steel cover and layout dimensions are identical.

#### CAPACITY

The cover is designed to accommodate up to three type S-1 switch mechanisms, or two double pole (type DPS-1) switch mechanisms.

NEMA ① TYPE NO.	APPLICATION
1	General Purpose
2	Splash Proof
3	Weather Resistant ②
3R	Rain Tight ②
4	Water Tight ②

① National Electrical Manufacturers Association classifications.

② For use only in non hazardous location applications.

### EXPLOSION PROOF HOUSING WITH DOUBLE TAP CONDUIT CONNECTIONS

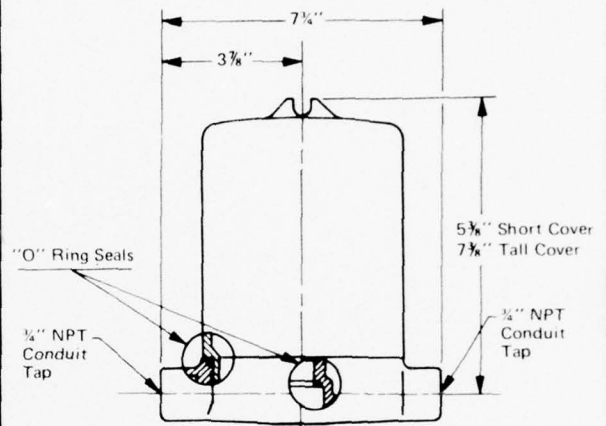

NOTE: Dimensions given are subject to change without notice.

#### DESCRIPTION

Explosion proof switch housings with double tap conduit connections are used interchangeably with standard Magnetrol steel and explosion proof housings in applications where two currents of different voltages are being controlled and electric code requires separate conduit connections for each. They also provide convenience for "series" type wiring connections in multiple control arrangements.

### CLASS 1, GROUP "B" ① EXPLOSION PROOF HOUSING

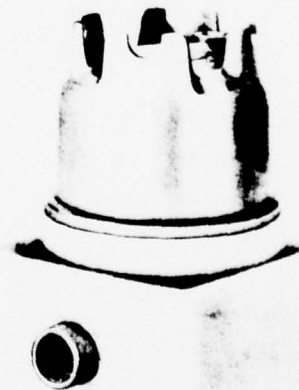

#### DESCRIPTION

The class 1, group "B" housing is of the explosion proof type approved for use in hazardous locations having hydrogen atmospheric potential. This housing is constructed of a special alloy and uses openings of long threaded close tolerance design to protect against the high degree of flame propagation associated with hydrogen.

# SWITCH WIRING

## WIRING PROCEDURE

Magnetrol switch mechanisms and housings are designed for maximum ease of wiring. Each mechanism has a terminal block positioned in full view, with housing cover removed. Terminal connections are plainly numbered to coincide with those in common use. Most switch housings are rotatable through a full 360° to allow convenient positioning of conduit opening. A typical wiring procedure is as follows:

1. Loosen base locking screw(s) and position conduit opening. Re-tighten screw(s).
2. Remove switch housing cover and pull in supply wires (conductors). Wrap wires around enclosing tube underneath baffle plate and bring up to terminals.
3. Connect wires to proper terminals and position excess wiring to provide adequate clearance for replacement of housing cover. Check to be certain wires do not interfere with "tilt" of switch.
4. Connect power supply to control and test switch actuation by varying liquid level or flow. Replace switch housing cover and place control into service.

## TERMINAL CONNECTIONS

Terminal connections shown in the following wiring diagrams are typical for direct acting Magnetrol controls. Switch actuation is reversed on side mounting controls which employ a reversing pivot.

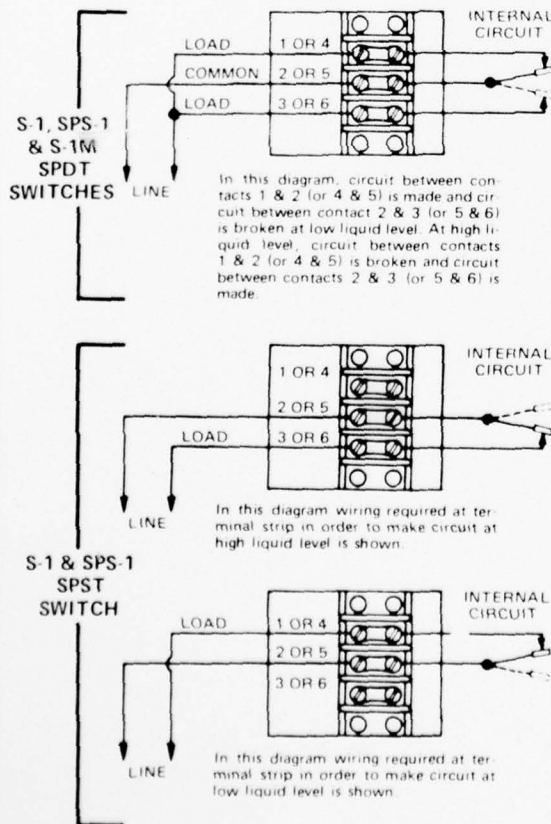

## DPS-1, SPDS-1 & DPS-1M DPDT SWITCHES

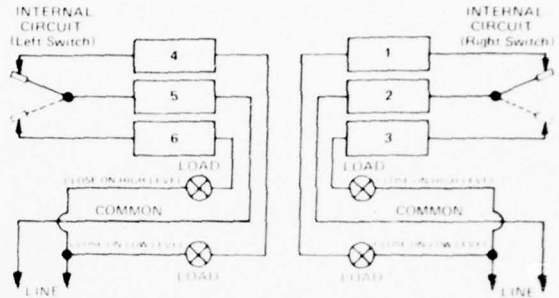

NOTE: On SPDS-1 mechanisms, diagram would apply to unit with two SPDT switches only.

## SPS-1 TWO CIRCUITS TO COMMON GROUND

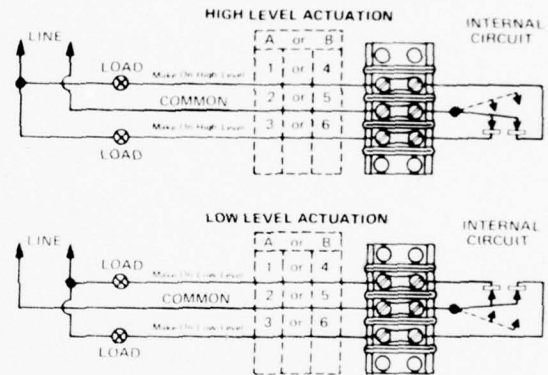

NOTE: For single pole, single throw action connect to any two terminals.

## M-1 SPDT SWITCH

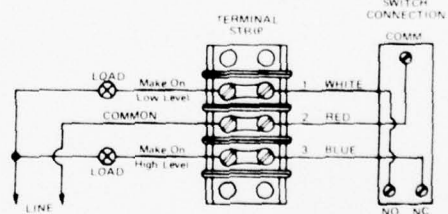

## M-1 & M-4 DPDT SWITCHES

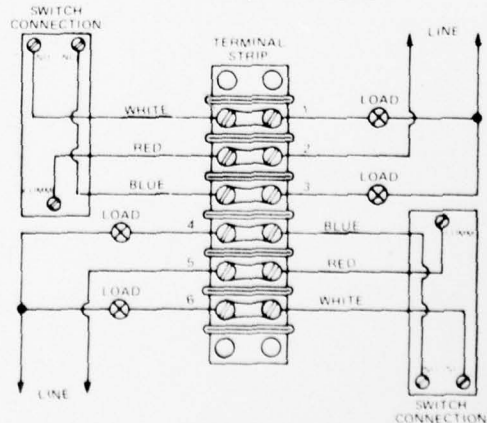

APPENDIX A-5

SKINNER ELECTRIC VALVES - SOLENOID VALVES

# SKINNER ELECTRIC VALVE DIVISION

New Britain, Connecticut

## MAINTENANCE AND CLEANING INSTRUCTIONS

### C, V5, X5, Q5 and V61 Series Valves

1. Shut off pressure to the valve and electric current. The valve need not be removed from the line.
2. Remove nut at top of coil cover. Cap, coil housing and coil can then be removed from body.
3. Using special Skinner wrench nut (Skinner Part V0-233) unscrew the sleeve assembly from the body. DO NOT use a pipe wrench, as a wrench may crush the sleeve assembly and make the valve inoperative.
4. In order to completely disassemble the Q5 valve, it is necessary to remove the snap ring from the recess in the bottom of the valve body or in Q5 valves manufactured after 1968 a threaded plug with holes fitting the V0-233 wrench nut. The cap, "O" ring and piston may then be removed.

### INSPECTION:

1. If the valve fails to operate, the coil should be checked to make sure it is not burned out.
2. Occasionally, if mishandled, valves may leak at the flange seal. If the medium is a liquid, such a leak may damage the coil. A flange leak may be corrected by tightening the sleeve assembly into the valve body or replacing the flange seal. Use wrench nut, Skinner Part V0-233. Do not use a pipe wrench on the sleeve assembly.
3. If the valve leaks at the seat or the plunger sticks in the energized position, examine the soft inserts in the plunger and the inside of the sleeve assembly for the presence of excessive dirt or wear. If the inserts show considerable wear, the plunger should be replaced.
4. If the valve develops a loud buzzing noise, examine the inside of the sleeve assembly and upper portion of the plunger and remove all foreign matter imbedded in these parts. Caution: In Three-Way and Two-Way Normally Open Valves be careful not to damage the sleeve seat. Clean the plunger assembly and seals with kerosene. Do not expose the rubber parts to any type of commercial cleaning fluid.
5. If external leakage occurs around the cap of the Q5 valve, the seal should be removed and inspected for imperfections.

If the valve leaks internally, examine the piston insert for excessive wear. Also inspect main exhaust orifice for dirt accumulation, scratches and nicks.

If the valve is sluggish during energization and de-energization, check for dirt accumulation or wear on both piston and piston bore. The piston should slide freely into the piston bore without binding. Inspect and clean all passageways of dirt or foreign matter.

### REASSEMBLY:

Reassemble the valve by following the disassembly procedure in reverse order. Make sure the seal at the flange end of the assembly and the return spring are in place when the sleeve is screwed into the body. After screwing the flange into the body and before assembling the coil to the valve, it is advisable to apply pressure to the port which leads to the body chamber and check for leakage around the flange. If the valve has a sleeve port, this port at the top of the valve must be capped to make this test. If the medium is air or gas, leakage can be noted by applying water to the joint and watching for air bubbles. If the medium is liquid, leakage is readily apparent. DO NOT tighten the nut at the top of the coil housing excessively, since doing so will put an undue strain on the sleeve assembly.

### REPLACEMENT PARTS:

Orders for replacement parts should include:

1. Part Description
2. Valve Number
3. Voltage



THE CREST OF QUALITY

# SKINNER ELECTRIC VALVES

SKINNER ELECTRIC VALVE DIVISION  
SKINNER PRECISION INDUSTRIES, INC. • NEW BRITAIN, CONNECTICUT, U.S.A.

## WORLDWIDE DISTRIBUTOR DIRECTORY

### UNITED STATES

#### ALABAMA

##### Homewood (Birmingham)

ACTIVATION, INC.  
P.O. Box 58067  
West Valley Avenue  
Phone: 871-0353 Zip 35209

#### ALASKA

##### Anchorage

ALASKA INSTRUMENT COMPANY  
P.O. Box 4-1123  
Phone: 277-9612 Zip 99503

#### ARIZONA

##### Phoenix

AIR DRAULICS COMPANY  
P.O. Box 11689  
3135 N. 29th Avenue  
Phone: 254-8414 Zip 85017

METROPOLITAN SUPPLY CO.  
3058 West Clarendon Avenue  
Phone: 264-1003 Zip 85017

##### Tucson

AIR DRAULICS COMPANY  
2021 East 13th Street  
Phone: 624-7604 Zip 85719

#### ARKANSAS

##### Little Rock

JACK TYLER ENGINEERING CO.  
6112 Patterson Avenue  
Phone: 562-2296 Zip 72209

#### CALIFORNIA

##### Burbank (Los Angeles)

HASKEL ENGINEERING & SUPPLY CO.  
100 E. Graham Place  
Phone: 843-4000 Zip 91502

##### Montebello (Los Angeles)

METROPOLITAN SUPPLY COMPANY  
1153 So. Greenwood Avenue  
Phone: 726-2434 Zip 90640

##### Oakland

CON VAL INCORPORATED  
412 Pendleton Way  
Phone: 568-8922 Zip 94621

##### San Diego

BARBEE VALVE & SUPPLY, INC.  
2116 Hancock Street  
Phone: 297-4213 Zip 92110

#### San Francisco

CALIFORNIA INSTRUMENT COMPANY  
351 Tenth Street  
Phone: 863-0350 Zip 94103

HASKEL ENGINEERING & SUPPLY CO.  
1228 Folsom Street  
Phone: 863-1489 Zip 94103

#### COLORADO

##### Denver

HASKEL ENGINEERING & SUPPLY CO.  
2262 S. Broadway  
Phone: 744-6456 Zip 80210

WARREN ENGINEERING CORP.  
2496 West 2nd Avenue  
Phone: 936-8261 Zip 80223

#### CONNECTICUT

##### Bridgeport

KNOX, INC. OF CONNECTICUT  
333 North Avenue  
Phone: 368-3421 Zip 06606

##### West Hartford

AUTOMATION, INC.  
456 Oakwood Avenue  
Phone: 236-5991 Zip 06110

SILLITER HOLDEN, INC.  
Box 10500  
433 New Park Avenue  
Phone: 232-4433 Zip 06110

#### FLORIDA

##### Hialeah (Miami)

AIR EQUIPMENT COMPANY  
854 West 20th Street  
Phone: 885-5371 Zip 33010

##### Jacksonville

CIRCUIT ENGINEERING, INC.  
8421 Atlantic Boulevard  
Phone: 721-1414 Zip 32211

##### Orlando

HARRY P. LEU, INC.  
P.O. Box 2513  
100 W. Livingston St.  
Phone: 843-1251 Zip 32802

##### Tampa

HARRY P. LEU, INC.  
3701 Grace St.  
Phone: 877-5805 Zip 33607

#### GEORGIA

##### Atlanta

ACTIVATION INC. OF GA.  
1252 Murphy Ave., S.W.  
Phone: 755-6691 Zip 30324

#### Atlanta (cont.)

JAY INSTRUMENT & SPECIALTY CO.  
532 Armour Circle, N.E.  
Phone: 873-6137 Zip 30324

#### HAWAII

##### Honolulu

YETT COMPANY, INC.  
429 Waiakamilo Road  
Phone: 848-0337 Zip 96817

#### IDAHO

##### Boise

PAUL ROBERTS CO.  
SUB. OF POWER TRANSMISSION PRODS.  
P.O. Box 7218  
Americana Terrace  
Phone: 344-8442 Zip 83705

##### Idaho Falls

PAUL ROBERTS CO.  
SUB. OF POWER TRANSMISSION PRODS.  
P.O. Box 2229  
465 South Utah  
Phone: 522-7455 Zip 83401

##### Pocatello

PAUL ROBERTS CO.  
SUB. OF POWER TRANSMISSION PRODS.  
P.O. Box 1689  
850 South Main Street  
Phone: 232-3672 Zip 83201

#### ILLINOIS

##### Broadview (Chicago)

CATCHING ENGINEERING COMPANY  
2101 Roberts Drive  
Phone: 344-2334 Zip 60153

##### Chicago

AIR CONTROL, INC.  
2917 West Irving Park Road  
Phone: 463-0035 Zip 60618

FLOW PRODUCTS, INC.  
2626 West Addison Street  
Phone: 528-2000 Zip 60618

NORMAN EQUIPMENT COMPANY, INC.  
7659 South Western Avenue  
Phone: 434-2300 Zip 60620

##### Peoria

NORMAN EQUIPMENT COMPANY, INC.  
2727 N.E. Adams Street  
Phone: 685-1092 Zip 61603

##### Rockford

NORMAN EQUIPMENT COMPANY, INC.  
3815 Broadway  
Phone: 398-7535 Zip 61108

**INDIANA****Fort Wayne**

TEC HACKETT ENGINEERING, INC.  
P.O. Box 57  
646 Growth Avenue  
Phone: 742-8261 Zip 46801

**Indianapolis**

JAY INSTRUMENT & SPECIALTY CO.  
1901 W. 15th Street  
Phone: 639-6494 Zip 46202

TEC HACKETT ENGINEERING, INC.  
P.O. Box 68514  
6232 LaPas Trail  
Phone: 299-6327 Zip 46268

**IOWA****Bettendorf**

NORMAN EQUIPMENT COMPANY, INC.  
P.O. Box 694  
3813 State Street  
Phone: 355-5305 Zip 52722

**KANSAS****Kansas City**

POWERFLOW SYSTEMS INC.  
1401 Fairfax Trafficway  
Phone: 342-7024 Zip 66115

**Shawnee**

SKARDA EQUIPMENT COMPANY, INC.  
P.O. Box 3114  
12212 Johnson Drive  
Phone: 631-7001 Zip 66203

**Wichita**

FLUID MOTION, INC.  
3665 McCormick  
Phone: 942-1289 Zip 67213

**KENTUCKY****Louisville**

JAY INSTRUMENT & SPECIALTY CO.  
3849 Cane Run Road  
Phone: 778-6609 Zip 40211

AIR HYDRO POWER, INC.  
4400 Bishop Lane  
Phone: 451-1000 Zip 40218

**LOUISIANA****Baton Rouge**

LUMAC, INC.  
P.O. Drawer 3337  
3626 Seneca Street  
Phone: 357-0655 Zip 70821

**Harvey**

AIR DRECO, INC.  
P.O. Box 13  
208 Pallet Drive  
Phone: 367-7260 Zip 70058

**MAINE****Portland**

LEEN'S POWER ENGINEERING CO.  
52 Union Street  
Phone: 774-6266 Zip 04111

**MARYLAND****Baltimore**

CURTIS ENGINE & EQUIPMENT CO., INC.  
6120 Holabird Avenue  
Phone: 633-5161 Zip 21224

LOUIS H. HEIN COMPANY  
4905 Pennington Avenue  
Phone: 354-1800 Zip 21226

**Cockeysville**

AIRLINE HYDRAULICS CORP.  
Beaver Dam Industrial Park  
107 Beaver St.  
Phone: 667-4300 Zip 21030

**MASSACHUSETTS****Needham Hgts. (Boston)**

FLUID POWER PRODUCTS, INC.  
19 Kearney Road  
Phone: 449-2440 Zip 02194

**South Walpole (Boston)**

KNOX, INC.  
Foxhill Drive  
U.S. Route No. 1  
Phone: 668-1270 Zip 02071

**West Springfield**

KNOX, INC.  
94 Doty Circle  
Phone: 788-9691 Zip 01089

**MICHIGAN****Detroit**

RALPH D. ERNEST ASSOCIATES, INC.  
12818 Puritan Avenue  
Phone: 861-7311 Zip 48227

INDUSTRIAL AIR & HYDRAULIC EQUIP.  
CO.  
20430 Sherwood Avenue  
Phone: 366-8134 Zip 48234

**Fenton (Flint)**

KUNDINGER FLUID POWER, INC.  
100 Alloy Drive  
Phone: 629-2248 Zip 48430

**Grand Rapids**

BARCLAY, AYERS & BERTSCH CO.  
1655 Steele Street, S.W.  
Phone: 452-3251 Zip 49502

**MINNESOTA****Minneapolis**

AIR ENGINEERING & SUPPLY COMPANY  
2719 E. Franklin Avenue  
Phone: 335-4181 Zip 55406

J. E. BRAAS CO.  
84 West 78th Street  
Phone: 869-3246 Zip 55423

**MISSOURI****St. Louis**

JOHN HENRY FOSTER COMPANY, INC.  
10740 Midwest Industrial Blvd.  
Phone: 427-0600 Zip 63132

**Springfield**

OZARK FLUID POWER  
832 St. Louis St.  
Phone: 869-7301 Zip 65806

**MONTANA****Missoula**

POWER TRANSMISSION & BEARING  
PRODUCTS, INC.  
P.O. Box 1017  
Montana & Russell Sts.  
Phone: 549-6452 Zip 59801

**NEBRASKA****Omaha**

SKARDA EQUIPMENT COMPANY, INC.  
P.O. Box 3568  
1227 So. 22nd St.  
Phone: 422-0430 Zip 68103

**NEW JERSEY****Maplewood (Newark)**

THE AIROYAL COMPANY  
43 Newark Way  
Phone: 761-4150 Zip 07040

**Cedar Knolls**

JARETT INDUSTRIES, INC.  
11 Saddle Road  
Phone: 539-4410 Zip 07927

**Clifton**

LOUIS H. HEIN COMPANY  
2 Pleasant Avenue  
Phone: 471-2111 Zip 07013

**South Bound Brook**

DAHL-GOEHRING & ASSOCIATES, INC.  
80 Main Street  
Phone: 469-5454 Zip 08880

**NEW MEXICO****Albuquerque**

AIR DRAULICS COMPANY  
P.O. Box 6509  
3117 Claremont Ave. N.E.  
Phone: 345-3421 Zip 87107

**NEW YORK****Brooklyn**

TRI STATE SUPPLY COMPANY OF N.Y.  
161 Jamaica Avenue  
Phone: 647-1221 Zip 11207

**Buffalo**

ERIE INDUSTRIAL SUPPLY CO., INC.  
2075 Fillmore Avenue  
Phone: 835-8813 Zip 14214

**Mount Vernon**

POWER DRAULICS NIELSEN, INC.  
550 South Columbus Avenue  
Phone: 668-3800 Zip 10550

**New York City**

MONOGRAM PRODUCTS CORP., INC.  
14 Wooster Street  
Phone: 966-4080 Zip 10013

**North Tonawanda**

K.D. SUPPLY CORPORATION  
P.O. Box 549  
601 Erie Avenue  
Phone: 693-7600 Zip 14120

## Rochester

GENESEE AIR HYDRAULIC SALES, INC.  
1732 Hudson Avenue  
Phone: 266-0422 Zip 14617

## Syracuse

GENESEE MENDON AIR HYDRAULIC  
SALES, INC.  
6600 Joy Road  
Phone: 437-7549 Zip 13057

## Tonawanda

CAVAC FLUID POWER, INC.  
2005 Niagara Falls Blvd.  
Phone: 691-6642 Zip 14150

## NORTH CAROLINA

### Charlotte

Cv, INC.  
1141 Commercial Ave.  
Phone: 332-8084 Zip 28205

ROBERT S. HUGHES COMPANY  
P.O. Box 17217  
1112 McAlwy Road  
Phone: 366-4887 Zip 28211

### Clemmons

Cv, INC.  
Box 988  
Lot 30 — Ashfield Drive  
Phone: 945-5562 Zip 27012

## OHIO

### Akron

B. W. ROGERS COMPANY  
P.O. Box 1030  
380 Water Street  
Phone: 762-0251 Zip 44309

### Brookfield

ERIE INDUSTRIAL SUPPLY CO., INC.  
2500 Parkway Drive  
Phone: 448-4075 Zip 44403

### Cincinnati

JAY INSTRUMENT & SPECIALTY CO.  
555 North Wayne Avenue  
Phone: 733-5200 Zip 45215  
B. W. ROGERS COMPANY  
637 Redna Terrace  
Phone: 771-5860 Zip 45215

### Cleveland

KEYSTONE COMPONENTS, INC.  
880 East 185th St.  
Phone: 486-5880 Zip 44119

### Columbus

B. W. ROGERS COMPANY  
1188 W. 3rd Avenue  
Phone: 294-5636 Zip 43212

### Dayton

JAY INSTRUMENT & SPECIALTY CO.  
2950 Dryden Road  
Phone: 298-7373 Zip 45439  
B. W. ROGERS COMPANY  
169 East Helena Street  
Phone: 223-9712 Zip 45404

### Euclid

AIR OIL PRODUCTS, INC.  
Sub. of B. W. Rogers Company  
21701 Tungsten Road  
Phone: 531-7720 Zip 44117

## Lakewood (Cleveland)

LAKEWOOD TOOL & SUPPLY COMPANY  
1388 Riverside  
Phone: 221-4820 Zip 44107

## Toledo

MIDWEST FLUID POWER COMPANY  
4325 Harris Street  
Phone: 478-9086 Zip 43613

## OKLAHOMA

### Oklahoma City

NIX SUPPLY CO.  
P.O. Box 94936  
2230 South Prospect Street  
Phone: 677-6622 Zip 73109

### Tulsa

NIX SUPPLY CO.  
2521 Charles Page Blvd.  
Phone: 582-9915 Zip 74127

## OREGON

### Albany

POWER TRANSMISSION & BEARING  
PRODUCTS, INC.  
P.O. Box 726  
102 S. Main Street  
Phone: 926-4286 Zip 97321

### Coos Bay

POWER TRANSMISSION & BEARING  
PRODUCTS, INC.  
P.O. Box 240  
824 N. Front Street  
Phone: 267-4159 Zip 97420

### Eugene

POWER TRANSMISSION & BEARING  
PRODUCTS, INC.  
516 Lawrence Street  
Box 1354  
Phone: 342-8104 Zip 97401

### Klamath Falls

POWER TRANSMISSION & BEARING  
PRODUCTS, INC.  
P.O. Box 936  
710 S. 6th Street  
Phone: 884-0623 Zip 97601

### LaGrande

POWER TRANSMISSION & BEARING  
PRODUCTS, INC.  
Drawer G  
1507 Jefferson  
Phone: 963-4186 Zip 97850

### Medford

HYDRAULIC & AIR EQUIPMENT CO.  
1234 Court Street  
Phone: 779-3911 Zip 97501  
POWER TRANSMISSION & BEARING  
PRODUCTS, INC.  
1209 Court Street  
Phone: 779-4045 Zip 97501

### Portland

HYDRAULIC & AIR EQUIPMENT CO.  
1925 N. W. Quimby  
Phone: 222-3295 Zip 97209  
POWER TRANSMISSION PRODUCTS  
1107 N. W. 14th Avenue  
Phone: 227-1271 Zip 97209

## Redmond

POWER TRANSMISSION & BEARING  
PRODUCTS, INC.  
P.O. Box 177  
125 East Evergreen  
Phone: 548-4561 Zip 97756

## Roseburg

POWER TRANSMISSION & BEARING  
PRODUCTS, INC.  
P.O. Box 838  
1227 N. E. Walnut  
Phone: 673-5549 Zip 97470

## Salem

POWER TRANSMISSION & BEARING  
PRODUCTS, INC.  
P.O. Box 271  
2255 McGilchrist St., S.E.  
Phone: 588-0780 Zip 97302

## PENNSYLVANIA

### Allentown

LOUIS H. HEIN COMPANY  
444 East Cedar Street  
Phone: 435-9661 Zip 18103

### Broomall (Phila.)

JOHN C. WHIDDETT COMPANY  
630 Parkway  
Phone: 353-6343 Zip 19008

### Erie

ERIE INDUSTRIAL SUPPLY CO., INC.  
P.O. Box 6004  
931 Greengarden Blvd.  
Phone: 453-6031 Zip 16512

### Cornwells Hts.

AIRLINE HYDRAULICS CORP.  
Expressway 95  
Industrial Center  
1-95 & Street Road  
Phone: 638-4700 Zip 19020

### Pittsburgh

RITTER ENGINEERING COMPANY  
540 Delwar Road  
Phone: 882-9700 Zip 15236

### West Conshohocken

LOUIS H. HEIN COMPANY  
1151 Matsons Ford Road  
Phone: 828-5500 Zip 19428

## RHODE ISLAND

### Providence

BRIAN SUPPLY CO.  
Fluid Power Division  
111 Chestnut Street  
Phone: 272-6400 Zip 02903

## TENNESSEE

### Chattanooga

AIR DRAULICS, INC.  
P.O. Box 3186  
1308 East 23rd Street  
Phone: 698-4061 Zip 37404

## Kingsport

ABERNATHY THOMAS ENGINEERING CO.  
535 537 E. Sullivan Street  
Phone: 245-6151 Zip 37662

## Memphis

FLUID POWER OF MEMPHIS  
P.O. Box 14797  
2248 Dunn Road  
Phone: 743-1122 Zip 38114

## TEXAS

### Dallas

AIR DRECO, INC.  
P.O. Box 35652  
1471 Prudential Drive  
Phone: 638-7070 Zip 75235

### Houston

AIR DRECO, INC.  
P.O. Box 10928  
2230 Governor Circle West  
Phone: 681-4601 Zip 77018

### Midland

LINCO ELECTROMATIC, INC.  
P.O. Box 4096  
4580 West Hwy. 80  
Phone: 694-9644 Zip 79701

## UTAH

### Salt Lake City

HASKEL ENGINEERING & SUPPLY CO.  
359 Ironwood Drive  
Phone: 487-2238 Zip 84115

THE RAINS COMPANY  
P.O. Box 15547  
370 Ironwood Drive  
Phone: 487-5678 Zip 84115

## VIRGINIA

### Richmond

LOUIS H. HEIN COMPANY  
5739 Hull Street Road  
Phone: 276-4305 Zip 23224

VIRGINIA-CAROLINA CONTROLS CO.  
P.O. Box 12084  
104 So. Foushee Street  
Phone: 648-2808 Zip 23241

## WASHINGTON

### Seattle

HASKEL ENGINEERING & SUPPLY CO.  
206 South Brandon Street  
Phone: 762-7222 Zip 98108

## Seattle (cont.)

HYDRAULIC & AIR EQUIPMENT CO.  
4401 Airport Way S.  
Phone: 682-1681 Zip 98108

## WEST VIRGINIA

### South Charleston

JAY INSTRUMENT & SPECIALTY CO.  
114 D Street  
Phone: 744-9406 Zip 25303

### Wheeling

SCOTT FLUID POWER PRODUCTS, INC.  
3825 Jacob Street  
Phone: 232-6006 Zip 26003

## WISCONSIN

### Milwaukee

NORMAN EQUIPMENT COMPANY, INC.  
136 North 120th Street  
Phone: 771-3100 Zip 53226

### Waukesha

PRICE ENGINEERING CO., INC.  
285 North Janacek Road  
Phone: 784-1260 Zip 53186

## CANADA

### ALBERTA

#### Calgary

CANTECH CONTROLS LTD.  
Box 5274 Postal Station A  
220 Glenmore Trail S.W.  
Phone: 252-8151

#### Edmonton

CANTECH CONTROLS LTD.  
10567 — 111th Street  
Phone: 425-9810

### BRITISH COLUMBIA

#### Vancouver V6J 1L8

CANTECH CONTROLS LTD.  
1601 West 4th Avenue  
Phone: 736-2851

### MANITOBA

#### Winnipeg 10,

APPLIED HYDRAULICS COMPANY  
DIVISION OF POWERCON LIMITED  
865 Wall Street  
Phone: 786-5808

### ONTARIO

#### Mississauga (Toronto)

DYCON LIMITED  
3063 Universal Drive  
Phone: 625-4350

#### Ottawa

COWPER COMPANY LIMITED  
270 MacLaren Street  
Phone: 232-7338

### QUEBEC

#### Lachine (Montreal)

COWPER COMPANY LIMITED  
677 — 7th Avenue  
Phone: 637-6746

## EUROPE

### AUSTRIA

DIPL. ING. DR. TECHN. HEINZ ZOEBL  
EIN UND AUSFUHRHANDELSGES, m.b.H.  
Maria Theresienstrasse 5  
Wien 9  
Phone: 72 53 91  
Telex: 75382

### BELGIUM

LA DYNAMIQUE APPLIQUEE S.A.  
Rue Tenbosch, 94  
1050 Brussels  
Phone: (02) 45.91.16  
Telex: 26385 LADYNA B

### DENMARK

DITZ SCHWEITZER A-S  
Hesselager 27  
DK 2600 Glostrup  
Phone: (01) 453044  
Telex: 15057

### ENGLAND

ARCA CONTROLS LTD.  
Queen's Engineering Works  
Bedford  
Phone: Bedford 60371/6  
Telex: 82486/7  
Cable: Pumpbedford Telex

### FINLAND

EKSTROMS MASKINAFAR  
Alexandersgatan 7  
Post Box 10310  
Helsinki 10  
Phone: 11421  
Telex: 12511

### FRANCE

S.E.I.E.M.  
Tour d'Asnières  
92606 Asnières  
Phone: (01) 7914444  
Telex: 61471

### GERMANY

DRUMAG GmbH DRUCKLUFTGERATE  
Glernerstrasse 2  
Postfach 222  
788 Sackingen/Rhein  
Phone: 8241-8242  
Telex: 792333

### HOLLAND

ERIKS N.V.  
Voormeer 33,  
Alkmaar  
Phone: 02200 41911 or 18877  
Telex: 57151  
Cable: EPRA  
(Subsidiaries at: Vlaardingen,  
Eindhoven, Enschede)

### IRELAND

GILROY AUTOMATION LIMITED  
17, Douglas West  
Cork  
Phone: (021) 33676  
Telex: 8449

## EUROPE (Continued)

### ITALY

HONEYWELL SpA  
Via Vittor Pisani 13  
20124 Milano  
Phone: 62.45  
Telex: 32092

### NORWAY

MORGENSTIERNE & CO. A.S.  
Ingenjörfirma  
P.B. 6688 Rodelökka  
Konghellegt. 3  
Oslo 5  
Phone: 372940  
Telex: 11719

### PORTUGAL

VALADAS LIMITADA  
Avenida D. Carlos 1  
60—Lisbon 2  
Phone: 663113  
Cable: Valadeiro  
Telex: 1866-Valado P

### SPAIN

ASESORAMIENTOS Y SUMINISTROS  
INDUSTRIALES S.A.  
("A.S.I.S.A.")  
Deu Y Mata 154  
Barcelona — 15  
Phone: 3210550  
Cable: Condifluid  
Telex: 54.170 HIDRA — Barcelona

### SWEDEN

GRANZOW A/B  
Tryckerigatan 10  
57100 Nassjö  
Phone: 0380/74300  
Telex: 3769

### SWITZERLAND

SPECKEN A.G.  
Böcklinstrasse 16  
Postfach 256  
8032 Zürich  
Phone: 01/34 62 63  
Cable: Metallurgie  
Telex: 57327 — Speag CH

## INTERCONTINENTAL

### AUSTRALIA

BOUSTEAD WOOD PTY. LTD.  
Technical Division  
P.O. Box 148 (Day & Egerton Sts.,  
Silverwater)  
Ermington 2115  
Sydney, New South Wales  
Phone: 648 3922  
Cable: "Winwooded" Sydney  
Telex: 790 22657

Branch Office:  
P.O. Box 120 (407 City Rd.)  
S. Melbourne, Victoria, 3205  
Phone: 69-7501  
Cable: "Winwooded" Melbourne  
Telex: 790 32795  
Also: Adelaide, Brisbane, & Perth

### BRAZIL

J. LOW-BEER S.A. COMERCIO E INDUSTRIA  
Caixa Postal 2110  
01 327 RUA TREZE DE MAIO, 204  
Sao Paulo  
Phone: 256-4115 & 256-3497  
Cable: LOW-BEER — S. PAULO  
Telex: 0309151 PBSP0 BR  
Branch: Rio De Janeiro

### INDIA

BALI INTERNATIONAL AGENCIES  
P.O. Bag 7059  
Mathuradas Estate  
Bombay 400 029  
Phone: 533076  
Cable: NUCLONICS

### IRAN

IRAN PAHNAB INDUSTRIAL COMPANY  
P.O. Box 3222  
346 Roosevelt Avenue  
Tehran  
Phones: 825232, 3, 629148-05-2482  
Cable: PAHNABINCO  
Telex: 2456

### ISRAEL

ZVI BLASS & CO. LTD.  
P.O. Box 912  
39, Peretz St., Tel-Aviv  
Phone: 625566  
Cable: Zviblassco

### JAPAN

JAPAN CONTROLS COMPANY, LTD.  
Central Post Office Box 1187  
Kowa Bldg. No. 3  
11 45, 1 Chome Akasaka  
Minato-ku, Tokyo 107  
Phone: 584 4251  
Telex: 781 26491  
Cable: Wayacols Tokyo  
Branches: Nagoya, Osaka

SKINNER INTERNATIONAL, INC.  
Tokunaga Building, 202  
82 Yamashita-cho, Naka-ku  
Yokohama  
Phone: (045) 681-4568  
Cable: Skinner Yokohama

### MEXICO

ENTERPRISE, S.A.  
Rodriguez Saro No. 424  
Mexico 12, D.F.  
Phone: 5 34-60 20  
Telex: 017-71-184  
Branches: Guadalajara, — Monterrey

### NEW ZEALAND

BOUSTEAD, WOOD (N.Z.) LTD.  
P.O. Box 9164, Newmarket  
11 McColl St.  
Auckland  
Phone: 500 728  
Cable: BOUSTEAD AUCKLAND  
WELLINGTON OFFICE  
G.P.O. Box 2738  
Cor. Cable & Taranaki Sts.  
Wellington  
Phone: 554 144  
Cable: BOUSTEAD WELLINGTON

### PUERTO RICO

GONZALEZ TRADING, INC.  
P.O. Box 13067 (Santurce)  
Ave. San Patricio No. 38  
Rio Piedras Zip 00908  
Phone: 783-9380  
Telex: 3252489 (Via RCA)  
3859253 (Other)  
Cable: GONTRA  
Branch: Ponce

### SINGAPORE, 14

ALPHA ENGINEERING (PTE) LTD.  
No. 27A/B, Lorong 13  
Geyland  
Phone: 461831/2  
Cable: "Alphaeng Singapore"  
Branch Office:  
ACO ENGINEERING Sdn. Bhd.  
Kuala Lumpur

### SOUTH AFRICA

S. A. INSTRUMENTATION SALES  
(PTY.) LTD.  
Private Bag 1001  
Edenvale, Transvaal  
Phone: 53-2571/2  
Cable: INSTRUM

### TRINIDAD

PROCESS EQUIPMENT CO. LTD.  
14, High Street  
P. O. Box 166  
San Fernando  
Phones: 652 4889 & 3422  
Cable: PROQUIP  
Branch Office:  
96, Abercromby Street  
Port Of Spain  
Phones: 62-34452, 35340

## SKINNER DISTRICT AND AREA MANAGERS

### NORTH-EAST DISTRICT

#### **Metropolitan N.Y.C. & Northern New Jersey**

A.A. Todres — Area Manager  
328 Georgian Dr.  
Paramus, New Jersey 07652  
Phone: (212) 227-2470

#### **Eastern Pennsylvania Delaware, Maryland, Virginia**

Rothenheber & Wurts, Inc.  
53 Cricket Ave.  
Ardmore (Phila.), Pennsylvania 19003  
Phone: (215) 649-6300

#### **New England States & Quebec, Canada**

R. J. Kelly — Area Manager  
400 Old Connecticut Path  
Framingham (Boston), Massachusetts 01701  
Phone: (617) 326-3550

#### **Upper New York State & Ontario, Canada**

R. A. Rushton — Area Manager  
181 Pond View Heights  
Rochester, New York 14612  
Phone: (716) 244-3180

### SOUTH-EAST DISTRICT

#### **Southeastern States**

R. G. Burkard — District Manager  
2220 Randolph Ct., N.E.  
Atlanta, Georgia 30345  
Phone: (404) 237-3306

#### **North & South Carolina, Eastern Tennessee**

S. V. Borrelli — Area Manager  
6026 Kingstree Drive  
Charlotte, North Carolina 28210  
Phone: (704) 525-9496

### MID-EAST DISTRICT

#### **Northeastern & Southeastern Ohio Western Pennsylvania & Wheeling, West Virginia**

G. A. Weaver — Area Manager  
P. O. Box 30155  
Parma, Ohio 44130  
Phone: (216) 391-8115

#### **Southwestern Ohio, West Virginia, Kentucky & Indiana**

W. M. Redman — Area Manager  
2465 Oxford-Reily Rd.  
Oxford, Ohio 45056  
Phone: (513) 681-3405

#### **Michigan & North Western Ohio**

C. W. Blessed — Area Manager  
323 Wimbleton  
Birmingham, Michigan 48008  
Phone: (313) 564-5633

### NORTH-CENTRAL DISTRICT

#### **Northern Illinois**

M. Stevenson — District Manager  
Skinner Precision Industries, Inc.  
Room 604  
1211 W. 22nd St.  
Oak Brook, Illinois 60521  
Phone: (312) 654-1886

#### **Wisconsin, Iowa, Minnesota, North & South Dakota, Saskatchewan & Manitoba, Canada**

R. F. Reiersen — Area Manager  
3004 West 71st St.  
Minneapolis, Minnesota 55423  
Phone: (612) 332-1041

### SOUTH-CENTRAL DISTRICT

#### **Texas, Arkansas, Oklahoma, Louisiana, Southern Mississippi**

R. A. Bowers — District Manager  
P. O. Box 20792  
Dallas, Texas 75220  
Phone: (410) 352-3543

#### **Missouri, Kansas, Nebraska, Colorado,**

G. A. Comstock — Area Manager  
1707 Walnut Circle  
Blue Springs, Missouri 64015  
Phone: (816) 356-2244

### WEST-COAST DISTRICT

#### **Northern California Northwestern States, Alberta & Vancouver, B.C., Canada**

C. W. Bibler — District Manager  
P. O. Box 175  
San Ramon, California 94583  
Phone: San Francisco  
(415) 885-2209

#### **Southern California, Arizona & New Mexico**

D. R. Parmaley — Area Manager  
P. O. Box 25430  
Los Angeles, California 90025  
Phone: (213) 477-9272

### HOME OFFICE

Skinner Electric Valve Division  
Skinner Precision Industries, Inc.  
95 Edgewood Avenue  
New Britain, Connecticut 06050  
Phone: (203) 225-6421  
TWX: (203) 225-2591  
Telex: 099-203  
R. A. Fradl, General Sales Mgr.

### EXPORT DEPARTMENT

Skinner International, Inc.  
95 Edgewood Avenue  
New Britain, Connecticut 06050  
Phone: (203) 225-6421  
TWX: (203) 225-2591  
Telex: 099-203

### EUROPEAN HEADQUARTERS

Skinner Europa B.V.  
Scherpdeel 30  
Roosendaal, Holland  
Phone: 01650 — 35855  
Telex: 54053  
W.A.G. de Wit, Marketing Director

APPENDIX B

PRESERVATIVES

## PRESERVATIVES

The material in this appendix is intended to provide layaway personnel a quick reference for the preservative and packing materials required to accomplish the layaway job. The material has been extracted from MIL-P-116F and TM 38-260.

### 1. Specifications for preservative materials

<u>Type</u>	<u>Description (Not Specification Title)</u>	<u>Number*</u>	<u>Title</u>
P-2	Thin Film Preservative (Soft Film, Cold Application)	MIL-C-16173 Gr. 2	Corrosion Preventive, Solvent Cutback, Cold Application
P-9	Very Light Preservative Oil (Cold Application)	VV-L-800	Lubrication Oil, General Purpose Preservative, Water Displacing, Low Temperature
P-10	Engine Preservative Oil	MIL-L-21260	Lubrication Oil, Internal Combustion Engine, Preservative
P-15	Hydraulic Preservative Oil	**	Hydraulic Fluid, Preservative

#### Notes:

- a. Complete list of preservatives are designated in MIL-P-116F. These items are only those specified in this procedure.
- b. Above compiled from MIL-P-116F, page 12, Table 11, Preservatives.

- c. \*Federal/Military Specifications: Latest addition and/or amendment to be adhered to.
- d. \*\*Material not designated by MIL Spec Per MIL-P-116F.

2. Description of Preservative Materials

The following information relating to preservative materials is intended to provide layaway personnel with required information relating to the preservatives specified in this plan.

- a. P-2 - MIL-C-16173 Gr. 2

This is the standard preservative material for exposed carbon steel surfaces. The material forms a non-hard film, with a maximum thickness of 2 mils (0.002 inch), which can be removed with relative ease using solvents. For application, it can be cut back with solvent or mixed with MIL-C-16173A Gr. 3 (P-3) to provide a thinner coating. It is used at full strength on exposed shafts, couplings, outside of valves, etc., and diluted for use as a preservative for internal surfaces of equipment. This material will normally require an overwrap of plastic sheet/paper for external application. If the grease is allowed to become hot (summer weather), it may flow from its application location. Do Not use this material on bearings or other parts that move in contact with another part. For lubricating service, use P-10 or P-11.

- b. P-9 - VV-L-800

This is a light weight preservative oil with added corrosion inhibitors. It should be used on closely fitted parts and assemblies for indoors storage such as machine tools, etc.

AD-A046 082

COMPUTER SCIENCES CORP FALLS CHURCH VA  
LAYAWAY PLAN FOR DIRECT DIGITAL CONTROL (DDC) SYSTEMS ON THE CO--ETC(U)  
OCT 75

F/G 19/1

DAAA21-75-C-0244

NL

UNCLASSIFIED

CSC/SD-75/4137

3 OF 3  
ADA  
046082

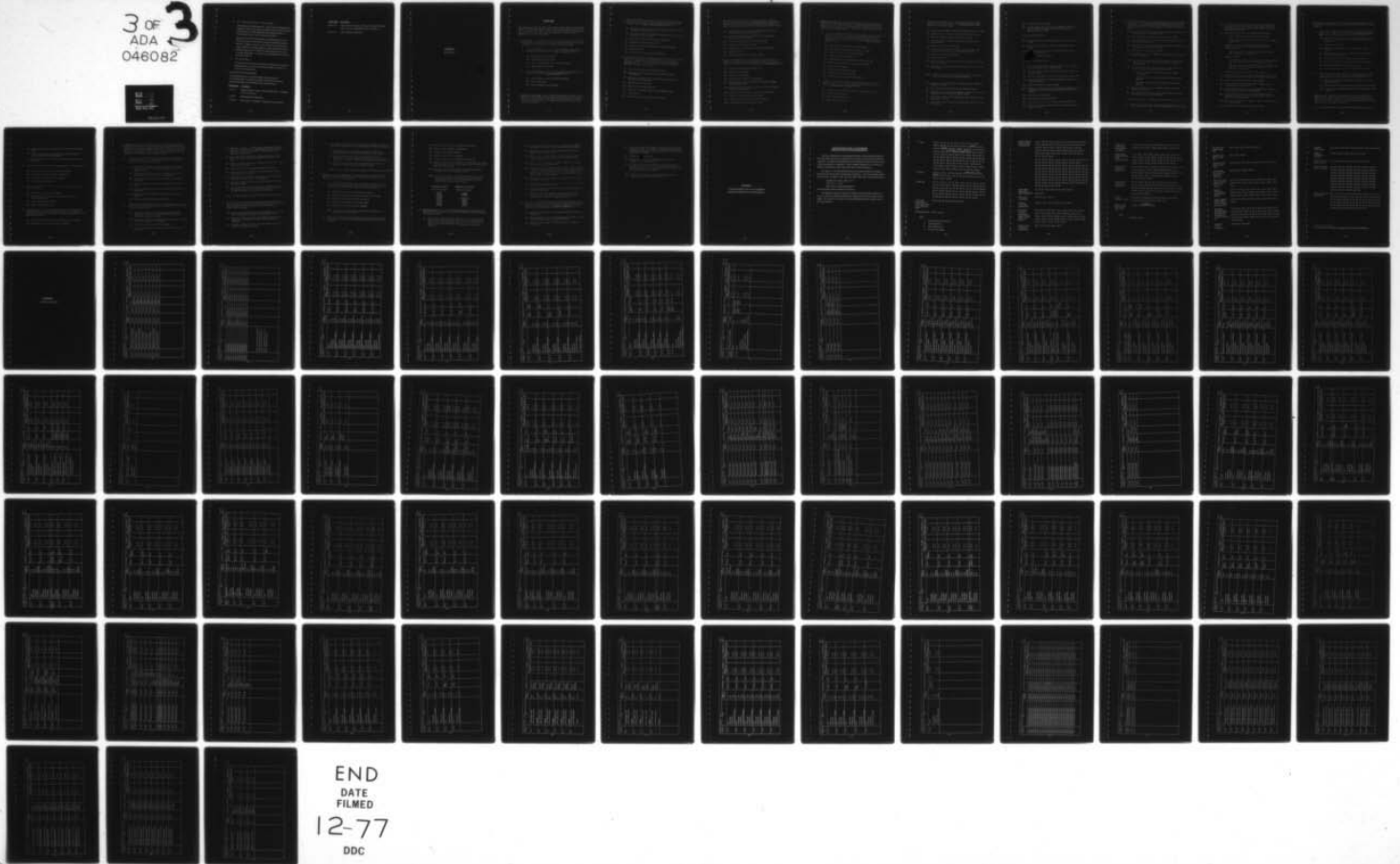

- c. P-10 - MIL-L-21260 (Type 1 - 10 wt. and 30 wt.)

This is preservative lubricating oil. It may be used for lubrication of compressor crank cases, pumps, ring oiled electric motors with sleeve bearings, blower bearing housing and speed reducers, gears, or in any location where an oil was used for lubrication.

Speed reducers, blower housings and steam engine crank cases and other places using a small amount of oil may be left filled with this lubricant. Do not use this oil as a preservative oil on the exterior of valves, pumps, steam engine cylinders, compressor piston rods and cylinders because it does not afford as much protection as P2 or P3. In specific applications, 10 weight oil has been specified for use rather than the 30 weight oil.

- d. P-15 (no MIL Spec.)

This hydraulic preservative oil is standard hydraulic oil with corrosion inhibitors added. It is used in all hydraulic cylinder/reservoirs for storage corrosion protection.

3. Specifications for Storage Materials

The following materials are required during layaway operations. These specifications are intended as a guide, and approved commercial equivalent materials may be utilized for these layaway actions.

<u>Specification</u>	<u>Description</u>
L-P-375	Plastic Sheeting, Flexible, Vinyl Chloride (Note: as available, use L-P-512, below)
L-P-512	Plastic Sheeting, Polyethylene
L-P-00524	Plastic Sheet, Polyethylene, laminated, nylon reinforced

<u>Specification</u>	<u>Description</u>
PPP-T-97	Tape, Pressure Sensitive, Adhesive, Filament Reinforced (Note: This is the equivalent of case house tape.)
PPP-T-60	Tape Packaging, Waterproof

APPENDIX C

WATER TEST

## WATER TEST

The operator will determine that all the valves in the system are closed, and all of the external and internal control loops are off control before any of the test procedures are begun. The necessary valves and loops will be enabled only at the proper time in the specified sequence of events. (Refer to Appendix C for all test sheet data)

1. DAYTANK TEST - The operator will fill the daytanks with water and verify that the plant equipment is operating properly and that there are no leaks. The following instrumentation and control tests will be done:
  - a. DAYTANK LEVEL CHECK - One at a time the following actions will be performed on the loops listed on DAYTANK TEST SHEET (Group A).
    - 1A. - Verify the level measurement
    - 1B. - Verify Hi/Lo absolute alarms
    - 1C. - Put the loop on control and verify valve action
    - 1D. - Verify high level override
  - b. DAYTANK FEEDPUMP CHECK - One at a time perform the following checks on the loops listed on DAYTANK TEST SHEET (Group B).
    - 2A. - Put the loop on control and read measurement
    - 2B. - Exercise the pump
    - 2C. - Check pump protection algorithm
2. RAW MATERIAL FLOW LOOPS - The daytanks will be full and the pumps will be running. CHN131 (the system feed permit) will be closed, and all individual feeds will be tripped (see RAW MATERIAL TEST SHEET - Groups A & C) when starting the following tests: (The operator again will check for leaks and proper operation.)

- a. TOLUENE AND NITRIC ACID FLOW CHECK - Enable the raw material flow loops one at a time manually and perform the following checks on the loops listed on RAW MATERIAL TEST SHEET (Group A).
- 1A. - Verify the valve action and flow reading by driving the valve manually from the controller.
  - 1B. - Put flow on control and verify DDC control action by observing O/P meter on the controller
  - 1C. - Drive FCV Feed Trip Contact to stop flow ( $=\emptyset$ )
  - 1D. - Verify flow =  $\emptyset$  (tight shut off)
  - 1E. - Restart flow and open overall feed trip (CNN131) ( $=\emptyset$ )
  - 1F. - Verify flow =  $\emptyset$
  - 1G. - Put SP =  $\emptyset$  and take flow loop off control
- b. OLEUM FLOW CHECK - Before starting this test the operator will insure that all of the oleum MV valves and CNN350 feed trip are closed. The following checks will be performed as listed on RAW MATERIAL TEST SHEET (Group B). The loops will be checked with their corresponding MV valves one at a time.
- 2A. - Drive MV valve open from operator's console
  - 2B. - Manipulate flow manually, take flow reading and verify valve action
  - 2C. - Put flow on control and verify DDC action by observing the O/P meter on the controller
  - 2D. - Drive MV valve to stop flow
  - 2E. - Verify flow =  $\emptyset$  (tight shut off)
  - 2F. - Restart flow and open overall feed trip (CNN131) ( $=\emptyset$ )
  - 2G. - Verify flow =  $\emptyset$
  - 2H. - Take flow loop off control and close MV valve

c. PURIFICATION AREA FLOW CHECK - The flow loops will be enabled manually one at a time as shown on RAW MATERIAL TEST SHEET (Group C). The testing of the two SO<sub>2</sub> flows will be done if the decision is made to put SO<sub>2</sub> into the system. The following checks will be done:

- 3A. - Verify the valve action and flow reading by driving the valve manually from the controller.
- 3B. - Put flow on control and verify DDC action by observing C/P meter on the controller.
- 3C. - Drive FCV feed trip contact to stop flow (=∅)
- 3D. - Verify flow = ∅ (tight shut off)
- 3E. - Restart flow and open overall feed trip (CNN131) (=∅)
- 3F. - Verify flow = ∅
- 3G. - Put SP = ∅ and take flow loop off control

d. ICOP FLOW ALGORITHM TEST - Two ICOP loops will be checked one at a time and each flow will be run to completion using the following step by step procedure on the loops listed on the ICOP FLOW TEST SHEET.

- 4A. - Put flow on control with setpoint = ∅
- 4B. - Ensure FCV valve closed
- 4C. - Put ICOP loop on control
- 4D. - Give ICOP loop a setpoint = Q<sub>T</sub> (target)
- 4E. - Close cascade and take initial flow measurement reading (note starting time)
- 4F. - In five minutes read flow measurement (in five more minutes read OV flow rate again)
- 4G. - Let flows run until cascade opens (note ending time)
- 4H. - Ensure flow = ∅ and FCV valve is closed
- 4I. - Read actual quantity Q<sub>A</sub> and compare it with Q<sub>T</sub>

\*NOTE: THE DAYTANK PUMPS MAY BE SHUT OFF NOW

3. PROCESS WATER TEST - The operator will determine that all the PW valves are closed before beginning this test. During this test the nitrators, separators, and the purification system will be filled with water. The operator will verify that the plant equipment is operating properly and that there are no system leaks.

a. NITRATOR PW HEADER SYSTEM CHECK - All the nitrator separator decanter levels will be raised to their highest position i.e., SP =  $\emptyset$  and the process water MV valves will be opened one at a time. The following checks will be performed as listed on PROCESS WATER TEST SHEET (Group A).

- 1A. - Decanter level on control and SP =  $\emptyset$  (raise)
- 1B. - Drive MV valve open from the operator's console
- 1C. - Verify the valve action and PW flow path
- 1D. - Read flow measurement FNN015
- 1E. - Trip CNN131 ( $\emptyset$ ) and verify flow =  $\emptyset$  (tight shut off)
- 1F. - Restart flow and fill the nitrator and separator
- 1G. - Drive MV valve closed
- 1H. - Verify flow =  $\emptyset$  (tight shut off)
- 1I. - Read decanter level measurement
- 1J. - Verify that drowning valves do not leak

b. SCRUBBER RECYCLE TANK PW CHECK - The operator will open the manual valve to fill this tank. The following action will be performed as shown on PROCESS WATER TEST SHEET (Group B).

- 2A. - Drive the pump on from the operator's console (CNN122) (1)
- 2B. - Verify the pump action
- 2C. - Stop the pump (CNN122 =  $\emptyset$ )
- 2D. - Close the manual valve

c. PURIFICATION PW FILLING CHECK - The purification section will be filled in the order shown below. See PROCESS WATER TEST SHEET (Group C) for loop information.

3A. - Lower decanter LNN062 to fill TNT Eductor Tank i.e., SP = MAX

3B. - Open flow valve FNN019 manually, and verify valve action

3C. - Put flow FNN019 on control and verify DDC action

3D. - Drive FCV-19EV valve from the operators console to stop flow (CNN431)

3E. - Verify flow = 0 (tight shut off)

3F. - Restart flow and fill PSEL Washer, TNT Eductor Tank, and verify CNN421 annunciator, Eductor Tank Level High

3G. - Trip the feeds using (CNN131 = 0)

3H. - Verify flow = 0

3I. - Raise decanter LNN062 and restart flow to finish filling PSEL Wash Water Tank.

3J. - Give flow loop FNN019 SP = 0 and verify flow = 0 (leave FNN019 on control)

\*NOTE: RECYCLE CONTROL LOOPS - The following checks assume closed flow is available to the finishing building.

3K. - Manipulate Recycle Pump Tank Level valve manually LNN010 and verify valve action

3L. - Put level loop LNN010 on control and verify DDC action

3M. - Give Recycle Pump Control loop LNN110 a setpoint lower than the measurement of LNN010 and put loop on control

3N. - Verify that CNN420 the TNT Recycle Pump is on, and the process flow path is correct

3P. - Give LNN110 a high setpoint to stop the pump, and take the loop off control

- 3Q. - Verify the pump has stopped
- 3R. - Let TNT Recycle Tank fill then give LNN010 a setpoint = 0 and verify that the valve is shut (tight shut off) and take the loop off control

#### EDUCTOR TANK CONTROL LOOPS

- 3S. - Manipulate level valve LNN011 manually and verify the valve action
- 3T. - Put level loop LNN011 on control and verify DDC control action
- 3U. - Lower the setpoint of LNN011 and verify that the valve is closed (tight shut off)
- 3V. - Take loop LNN011 off control

#### FILLING THE PURIFICATION TANKS

- 3W. - Lower decanters LNN059, LNN060, and LNN061 i.e., SP = MAX to fill the sellite washers and separators
- 3X. - Open flow valve FNN018 manually verify the valve action and flow measurement
- 3Y. - Put flow loop FNN018 on control and verify DDC control action
- 3Z. - Drive the FCV-18EV valve from the operators console to stop the flow (CNN430)
- 3AA. - Verify the flow = 0 (tight shut off)
- 3BB. - Restart the flow and fill the Acid Washer, the Sellite Washers, and the Sellite Separators (check annunciators CNN423 and CNN424)
- 3CC. - Do a feed trip (CNN131=0)
- 3DD. - Verify flow = 0 (tight shut off)
- 3EE. - Give the flow FNN018 a SP = 0 and take loop off control
- 3FF. - Read all level measurements (See list on Process Water Test Sheet - Group C)

d. PURIFICATION FLOW THRU CHECK - The following test will be performed as listed below. See PROCESS WATER TEST SHEET (Group D) for further information. The purpose of this test is to determine that the Flow Path from the Post Sellite Washer through to the Spent Acid Tank is correct.

4A. - Raise decanter LNN059 Awash Decanter Level (SP = 0), and lower NIT1B SEP Decanter LNN050 (SP = MAX)

4B. - Drive flow FNN030 manually and verify the valve action

4C. - Drive PSWW Pump CMM121 from the operator's console and verify the pump action (on/off)

4D. - Give LNN009 a setpoint < measurement, put loop on control, and verify that the pump (CMM121) is on

4E. - Put FNN030 on control with a setpoint

4F. - Give FNN019 a setpoint > FNN030 and verify flow measurement on FNN019 and FNN030

\*NOTE: Water should now flow into the Acid Washer, and from there to the YW Pump Tank. When the YW Pump Tank is filling do the following:

4G. - When the YW Pump Tank is approximately half-full (verify by LNN018 measurement) perform the following tests:

Start YW Pump Tank Pump (CMM401) by giving LNN018 a low setpoint

Verify YW flow to Nitrator 1B when LCV-8 is controlled manually

Check that measurement FNN011 responds to changes in YW flow

4H. - Put YW Pump Tank Level loop LNN018 on control and verify correct valve action

4I. - Give FNN030 a SP = 0 and verify that the YW flow tapers down and eventually stops (monitor FNN011)

\*NOTE: Restore the SP to FNN030 and proceed with the following tests:

4J. - Fill the Spent Acid Tank, check contact input CMM151 annunciator and, A43 Spent Acid Tank Level High. Verify over all YW flow path;

- 4J. - FSEL Washer to PSEL Wash Water Tank, to the Acid Washer, to the YW Tank and through Nitrator 1B Separator to the After Separator and into the Spent Acid Tank. (Refer to page C-15 for SETTLING AREA TEST)
- 4K. - Allow the YW Tank to fill, by shutting off the YW Pump:
- Raise LNN018 SP above the YW Pump Tank overflow
  - Verify annunciator A49, YW Pump Tank Level High - contact input CNN422
  - Lower the level in the YW Pump Tank, leaving the tank approximately half full for the agitator start up test: (Verify LNN078 SP)
  - Lower the setpoint for LNN018 to pump out the YW Pump Tank. (LNN018 SP < LNN078 SP)
- Shut off PW flows:
- Give FNN019 and FNN030 a SP = 0 and give LNN049 a high SP, this stops the Post Sellite Wash Water pump (CNN121)
  - Wait for flow FNN011 to reach zero then give LNN010 a high setpoint. This ensures that the YW Pump Tank Pump (CNN401) will remain off.
- Verify that the pumps are off and valves are closed
- 4L. - Record level measurements LNN038, LNN079, LNN057 and LNN058, and verify that they are high enough for the AGITATOR STARTUP TEST
- 4M. - Read the PH measurements ANN001 through ANN004
- 4N. - Give after SEP Airlift Airflow FNN028 a setpoint and read measurements, then give SP = 0
- 4P. - Give LNN118 CD Return Pump a setpoint (hi/lo) and verify pump action (CNN118) Leave pump off (CNN188=0)
- 4Q. - Drive CNN405 TNT Stand Pipe Drain valve (MV-78) from the operator's console and verify the valve action. Leave the valve closed. (To drain = 1)
- 4R. - Take all necessary loops off control. (Ref. list PROCESS WATER TEST SHEET Group D)
- 4S. - Check the level in any catch tanks if possible.

4. AGITATOR STARTUP TEST - All valves will be closed, the hydraulic system will be started, and the operator will verify that the system is running properly.
- a. NITRATOR AND SELLITE WASHER AGITATOR CHECK - The agitators will be started one at a time in the order shown on AGITATOR STARTUP TEST SHEET (Group A) and the following checks will be performed.
- 1A. - Drive the agitator min. speed contact (CNNXXX=0) from the operator's console to open the MV valve. (The SCV valve will be closed).
  - 1B. - Verify the valve action
  - 1C. - Verify that the agitator is at minimum speed. Adjust if necessary.
  - 1D. - Manually open the SCV valve partially to bring the agitator to a "safe" running speed.
  - 1E. - Adjust the SCV valve and read the speed measurement
  - 1F. - Close the MV valve for the agitator min. speed (CNNXXX=1)
  - 1G. - Verify valve action and that the speed = 0
  - 1H. - Put the speed loop on control and verify the DDC action
- b. PURIFICATION AREA AGITATOR CHECK - The agitators will be started one at a time in the order shown on AGITATOR STARTUP TEST SHEET (Group B) and the following checks will be performed.
- 1A. - Drive the contact from the operator's console to start the agitator (CNNXXX=1)
  - 1B. - Verify the agitator action and check the speed where possible
- \*NOTE: LEAVE ALL THE AGITATORS ON UNTIL THE TEMPERATURE CHECKS ARE COMPLETE.
5. HEAT/COOL TEST - There is an individual test sheet for each Nitrator/ Separator test. Before the test begins the loops and contacts will be set-up to permit steam flow to the Nitrator and Separator but the steam valves will be closed. (Refer to the HEAT/COOL TEST SHEET for the Nitrator being tested for all test shown below).
- a. NITRATOR HEAT TEST - Perform the following actions one at a time.

- 1A. - Put Nitrator Steam on control and raise S.P. 5% above measurement
  - 1B. - Verify heating takes place, and adjust the valve steps to give the required rate of heating
  - 1C. - Put steam loop S.P. to  $0^{\circ}\text{C}$  and allow Nitrator temperature to stabilize
- b. SEPARATOR HEAT TEST - Perform the following actions on the separators.
- 2A. - Set the separator control status for steam heat
  - 2B. - Verify S.P. of heating loop is above ambient
  - 2C. - Verify CD-CTR select valve for heating
  - 2D. - Verify heat up takes place
- c. SEPARATOR COOLING TEST - After heat up tests are complete perform the following actions.
- 3A. - Set the S.P. for the heating loop low
  - 3B. - Set CD-CTR select valve for cooling, and the S.P. for the cooling loop low
  - 3C. - Verify that setpoints are low
  - 3D. - Verify cooling takes place
- d. NITRATOR COOLING TEST - Set up the valves and loops as shown on the HEAT/COOL test sheet before beginning the test. Use a steam wand as a heat source, and heat each nitrator to operating temperature. Perform the following actions.
- 4A. - Close the cascade on the cooling loop and continue heating
  - 4B. - Verify cool valve operation under DDC control

6. ALARM LOGIC TEST - The alarm logic will be run independently of other (sequence) logic in order to test the emergency high temperature actions. This section also includes testing of the relay backup system. The steam wand will be used for the following tests. There is an ALARM LOGIC TEST SHEET for each nitrator. (Refer to ALARM LOGIC TEMP CONTROL diagram in Appendix C for the correct temperature parameters.)
- a. HIGH TEMPERATURE TEST - Start at operating temperature with loop and contact parameters as on ALARM LOGIC TEST SHEET 1 (Group A) initialize and start the alarm logic.
- 1A. - Close cascade on primary cooling loop and put the cooling setpoint to just below the value requiring changeover to nitrator heating
  - 1B. - Verify that nitrator temperature decreases rapidly and that changeover to heating takes place correctly.
  - 1C. - Verify coolant flow measurement by varying steam supply to steam wand
  - 1D. - Open CTS Supply Max vent valve, and verify maximum coolant flow.
  - 1E. - Close CTS Supply MAX vent valve, and verify coolant returns on control
  - 1F. - Repeat tests 1D & 1E using the system feed permit contact (CNN131).
  - 1G. - Restore control from the line panel switch
- b. NITRATOR RELAY BACKUP TEST - Start this test at normal run operating parameters. See ALARM LOGIC TEST SHEET 1 (Group B). The steam wand is used to maintain heat.
- 2A. - Raise Nitrator primary cooling setpoint to the high trip temperature. The nitrator temperature will rise slowly to the high tripping temperature.
  - 2B. - Verify that a relay trip takes place at the assigned temperature and that Max coolant flow is obtained
  - 2C. - Reset the trip manually from the line panel
  - 2D. - Close the cooling tower return valve. Verify coolant flow is now zero.

- 2E. - Using the steam wand raise the nitrator temperature to extra high value. Verify that the dump tripping mechanism activates correctly. (The final activation of the dump valve may be disabled for this test.)
- 2F. - Open cooling tower return valve and restore the nitrator to normal operating temperature. Restore trips from the line panel
- 2G. - Allow the nitrator temperature to stabilize, then using a steam wand, heat the nitrator
- 2H. - Verify that changeover to cooling control takes place
- 2J. - Allow temperature to stabilize. Increase Nitrator cooling loop setpoint to high limit
- 2K. - Verify that the alarm logic initiates a feed shutdown (CNN131 open =  $\emptyset$ ), and annunciates a feed shutdown
- 2L. - Wait approximately 2 minutes and verify nitrator CTS supply Max valve is open
- 2M. - Wait for nitrator to return to normal temperature range and verify that the vent valve is closed by the alarm logic, and the normal setpoint of the nitrator is restored.

\*NOTE: The operator must reset 'CTS MAX' switch on the line panel.

- c. NITRATOR RATE OF RISE TEST - Start this test with the Nitrator at normal run temperature as shown on ALARM LOGIC TEST SHEET 2 (Group C). Set a suitably small alarm value in the recipe for RRHI, the rate of rise alarm value.

- 3A. - Close the nitrator CTR return valve and verify a rate of rise trip. Verify the message and feed trip (CNN131 =  $\emptyset$ ).
- 3B. - Allow temperature to rise up to the high temperature value. Verify that the nitrator CTS Supply Max valve opens, immediately.
- 3C. - Open the nitrator CTR return valve and restore the nitrator to normal operating conditions.

d. NITRATOR DROWN TEST (ALARM LOGIC) - Start this test with the nitrator at normal operating condition. See ALARM LOGIC TEST SHEET 2 (Group D).

4A. - Stop the agitator for the selected nitrator. Verify the down valve trip. Restore normal operation to the nitrator.

4B. - Close the nitrator CTR valve and turn on steam to the separator. Verify that the down valve trips at the separator extra high temperature. Restore the nitrator to normal operation.

4C. - On one of the above tests the down valve will be allowed to trip open. Verify that the down valve is open.

\*NOTE: For other tests down valve opening, will be mechanically disabled.

7. PURIFICATION TEMPERATURE CHECK - The temperature tests in the Purification Section will be done as shown below and the operator will verify that all the equipment is operating properly.

a. TEMPERATURE TEST (CTS VALVES) - The temperature loops will be enabled one at a time manually and the tests listed below will be done on the loops shown on PURIFICATION TEMPERATURE TEST SHEET (Group A).

1A. - Verify the valve action and Temperature reading

1B. - Put Temperature loop on control and verify the DDC action

1C. - Drive the valve open/close from the console

1D. - Verify CTS flow stopped - valve shut tight

1E. - Leave loop on control with a low setpoint

\*NOTE: The control action of these loops will be verified when the Steam Valves are opened.

b. ON/OFF TEMPERATURE TEST (STEAM VALVES) - The checks listed below will be done one at a time on the loops listed on PURIFICATION TEST SHEET (Group B).

- 2A. - Put the loop on control and verify the DDC action
- 2B. - Give the loop a setpoint > measurement
- 2C. - Verify the Steam Valve is open
- 2D. - Give loop a setpoint < measurement
- 2E. - Verify the Steam Valve is closed (tight shut off)
- 2F. - Open the Steam Valves to the Acid Washer and Sellite Separators and verify the action of the CTS loops. Close the Steam Valves when done (See Group A).
- 2G. - Take all loops off control (Ref. list on the PURIFICATION TEMPERATURE TEST SHEET, Groups A. B. &C)

\*NOTE: All of the agitators in the Purification Section can now be stopped. (If any of the nitrator agitators are still on they should also be taken off control at this time.) Refer to the list of agitators below:

NITRATOR AGITATORS

PURIFICATION AGITATORS

(SP=Ø Off Control)

(SP=Ø Off Control)

SNNØØ1  
 SNNØØ2  
 SNNØØ3  
 SNNØØ4  
 SNNØØ5  
 SNNØØ6  
 SNNØØ7  
 SNNØØ8

SNNØØ9  
 SNNØ1Ø  
 (CNNXXX=Ø)  
 CNN416  
 CNN417  
 CNN418  
 CNN419

- 8. SETTLING AREA TEST - The tanks will be filled with water and the operator will verify that there are no system leaks and that all the plant equipment is operating properly.
  - a. SPENT ACID AND SPEND ACID SETTLE TANK TEST - Water will be pumped from the Spent Acid Tank, which was filled during the purification filling to the Spent Acid Settle Tank in the following order. The loops to be checked are shown on the SETTLING AREA TEST SHEET (Group A).

- 1A. - Manually open the LCV valve from the controller for LNN007, the Spent Acid Tank Level loop and verify the valve action.
  - 1B. - Put the loop on control and put the pump loop on control LNN007. Verify the DFC action.
  - 1C. - Set the Spent Acid Tank Level loop LNN007 setpoint to give approximately a half-full tank, i.e. pump into the Spent Acid Settling Tank.
  - 1D. - Give the pump loop LNN007 a setpoint < LNN007 SP and verify that the pump is on (CNN119 = 1)
  - 1E. - Manually open the LCV valve for LNN012 the Spent Acid Settling Tank Level loop, and verify the valve action. Read LNN012 level measurement and raise the setpoint on LNN007 to stop the pump when the level is high enough in the Spent Acid Settling Tank. Raise LNN007 SP to close LCV-7.
  - 1F. - Put LNN012 on control and put the pump loop LNN112 on control. Verify the DDC action.
  - 1G. - Give the pump loop LNN112 a setpoint  $\geq$  measurement and verify the on/off pump action (CNN120).
  - 1H. - If a flow to the Acid Recovery area can be made, FNN029 can be checked at this time.
  - 1I. - Verify that the pumps (CNN119 & CNN120) are off, and that LCV-7 and LCV-12 are closed. Take the loops listed on SETTLING AREA TEST SHEET - Group A off control.
- b. SETTLING TANK TESTS - The settling tanks will be filled with water, and the level control and pump protection circuitry will be checked. The loop information is shown on SETTLING AREA TEST SHEET (Group B). Each tank will be checked one at a time as listed below.
- 1A. - Check the contact input for the transfer tank level high, i.e. CNNXXX = 1
  - 1B. - Check all levels. On the RW Xfer Pmptk Level LNN040, manually open the control valve and verify the action
  - 1C. - Put the RW level loop on LNN040 on control, and verify the DDC action

- 1D. - Drive the pump contact (CNNXXX=1) from the operators console to start the pump. On LNN140 the RW Pmpk Pump control loop, put the loop on control and give it a setpoint < measurement. Verify the DDC action.
- 1E. - Verify that pump is on
- 1F. - Put the RW JK Out Temp. TNN037 on control and give it a setpoint. Verify the DDC action.
- 1G. - Raise LNN140 SP to stop the RW pump CNN126, and stop the remainder of the pumps from the operators console (CNNXXX=0). Refer to the list on the SETTLING AREA TEST SHEET - Group B. Take LNN040 and LNN140 off control.

\*NOTE: WATER FROM THE YW AND RW LINES WILL BE PUMPED TO THE NEUTRALIZATION AND DESTRUCTION AREAS.

APPENDIX D

CROSS-REFERENCE LIST OF TAG NUMBERS  
ASSOCIATED WITH SELECTED COMPONENTS

CROSS-REFERENCE LIST OF TAG NUMBERS  
ASSOCIATED WITH SELECTED COMPONENTS

The cross-reference list in this appendix provides a means whereby the layaway and reactivation contractors can checkoff each component as the various procedures are completed. It includes all the significant control components except the various by-pass valves and instrument air regulators. These unlisted components are serviced as an integral or related part of their associated valves or flow transmitters.

For lines 4, 5, and 6 the Model 63R Alarms are listed according to the label on each one in the rack located in the Hydraulic Pump House. The cross-reference between these AR series of numbers to the Loop TAG number of the sensor input will be found on

Drawing AC1P-1222-4, Sheet 1 of 5

TNT Line 4, 5, and 6

Relay Logic - Analog Backup System.

This drawing also lists the setting of each alarm.

The suggested approach for using this checklist is for the layaway contractor to cross out each TAG number horizontally with a light blue pencil so the number remains legible. The reactivation contractor can then checkoff each number in another color to record his progress.

V1 Valve

FCV-1, FCV-2, FCV-3, FCV-4, FCV-5, FCV-6, FCV-7,  
FCV-8, FCV-9, FCV-10, FCV-12, FCV-14, FCV-15, FCV-16,  
FCV-17, FCV-30, FCV-32, FCV-33, FCV-34A, B, FCV-38A, B,  
LCV-1, LCV-2, LCV-3, LCV-4, LCV-5, LCV-6, LCV-7, LCV-8,  
LCV-11, LCV-12, LCV-40, MV-3, MV-5, MV-6, MV-10, MV-12,  
MV-13, MV-16, MV-19, MV-20, MV-21, MV-29, MV-30, MV-36,  
MV-37, MV-46, MV-55, MV-63, MV-71, MV-72, MV-73, MV-76,  
MV-90, SCV-1, SCV-2, SCV-3, SCV-4, SCV-5, SCV-6, SCV-7,  
SCV-8, SCV-9, SCV-10, TCV-1, TCV-2, TCV-3, TCV-4, TCV-5,  
TCV-6, TCV-7, TCV-8, TCV-9, TCV-10, TCV-16, TCV-51.

V4A Valve

FCV-13, FCV-18, FCV-19, FCV-28, LCV-3, LCV-4, LCV-5,  
LCV-6, LCV-10, MV-2, MV-9, MV-18, MV-28, MV-35, MV-45,  
MV-54, MV-63, MV-93.

V9000 Valve

LCV-39, LCV-41, LCV-42, MV-1, MV-4, MV-8, MV-11, MV-15,  
MV-17, MV-22, MV-24, MV-25, MV-27, MV-31, MV-32, MV-34,  
MV-38, MV-39, MV-41, MV-42, MV-44, MV-47, MV-48, MV-50,  
MV-51, MV-53, MV-56, MV-57, MV-59, MV-60, MV-62, MV-65,  
MV-66, MV-68, MV-69, MV-74, MV-75, MV-79, MV-80, MV-81,  
MV-82, MV-83, MV-84, MV-85, MV-86, MV-87, MV-88.

F-45 Valve

(VAAP-Line 1)

V5310 Valve (Lines

4,5,6 VAAP and

JAAP)

MV-26, MV-43, MV-52, MV-61, MV-70.

G-2 Saunders Valve MV-78, MV-91.

Notes:

1. Formerly FCV-32 or FCV-33
2. Formerly LCV-9
3. Not in VAAP Line 1
4. In VAAP Line 1 Only

Skinner Solenoid  
Valves, Model  
X-53 and X-55

FCV-1, FCV-2, FCV-3, FCV-4, FCV-5, FCV-6, FCV-7, FCV-8,  
FCV-9, FCV-12, FCV-13, FCV-14, FCV-15, FCV-16, FCV-17,  
FCV-18, FCV-19, LCV-1, LCV-2, LCV-3, LCV-4, LCV-6,  
LCV-39, LCV-41, LCV-42, MV-1, MV-2, MV-3, MV-4, MV-5,  
MV-6, MV-7, MV-8, MV-9, MV-10, MV-11, MV-12, MV-13,  
MV-14, MV-15, MV-16.

MV-17, MV-18, MV-19, MV-20, MV-21, MV-22, MV-23, MV-24,  
MV-25, MV-26, MV-27, MV-28, MV-29, MV-30, MV-31,  
MV-32, MV-33, MV-34, MV-35, MV-36, MV-37, MV-38, MV-39,  
MV-40, MV-41, MV-42, MV-43, MV-44, MV-45, MV-46, MV-47,  
MV-48, MV-49, MV-50, MV-51, MV-52, MV-53, MV-54, MV-55,  
MV-56, MV-57, MV-58, MV-59, MV-60, MV-61, MV-62, MV-63,  
MV-64, MV-65, MV-66, MV-67, MV-68, MV-69, MV-70, MV-71,  
MV-72, MV-73, MV-74, MV-75, MV-76, MV-77, MV-78, MV-79,  
MV-80, MV-81, MV-82, MV-83, MV-84, MV-85, MV-86, MV-87,  
MV-88, MV-90, MV-91, MV-93.

Micro Switch  
Model 4EX-1  
Model EXD AR500

ES-2, ES-4, ES-8, ES-10, ES-12, ES-14, ES-16.  
ES-3, ES-9

13FA Level  
Transmitter

LT-39, LT-41, LT-42.

Pressure  
Transmitter  
Model E11GM

LT-50, LT-51, LT-52, LT-53, LT-54, LT-55.

Differential  
Pressure  
Transmitter  
Models E13DH,  
E13DL, and  
E13DM

DT-1, DT-3, DT-5, DT-7, FT-1, FT-2, FT-3, FT-4, FT-5,  
FT-6, FT-7, FT-8, FT-9, FT-11, FT-12, FT-13, FT-14,  
FT-15, FT-16, FT-17, FT-18, FT-19, FT-20, FT-21, FT-22,  
FT-23, FT-24, FT-25, FT-26, FT-27, FT-28, FT-29, FT-30,  
FT-31, FT-32, FT-33, FT-34, FT-38.

Buoyancy Level  
Transmitter  
Model E17BT

DT-2, DT-4, DT-6, DT-8, LT-50.

Liquid Level Transmitter Models E17DL, and E17DM	LT-1, LT-2, LT-3, LT-4, LT-5, LT-6, LT-7, LT-8, LT-9, LT-10, LT-11, LT-12, LT-40, LT-57, LT-58, LT-63, LT-64.
Orifice Plate, Flange and Union Model OPFTT-316-300	FT-1, FT-2, FT-3, FT-4, FT-5, FT-6, FT-7, FT-8, FT-9, FT-11, FT-12, FT-14, FT-15, FT-16, FT-17, FT-18, FT-19, FT-20, FT-21, FT-22, FT-23, FT-24, FT-25, FT-26, FT-27, FT-28, FT-29, FT-30, FT-32, FT-33, FT-34, FT-38.
Current-to-Air Positioner, Model 69PA-1	LCV-1, LCV-2, LCV-3, LCV-4, LCV-6, LCV-7, LCV-8, LCV-10, LCV-11, LCV-12, LCV-40, SCV-1, SCV-2, SCV-3, SCV-4, SCV-5, SCV-6, SCV-7, SCV-8, SCV-9, SCV-10, TCV-1, TCV-2, TCV-3, TCV-4, TCV-5, TCV-6, TCV-7, TCV-8, TCV-9, TCV-10, TCV-16, TCV-51.
Current-to-Air Transducer, Model 69TA-1	FCV-1, FCV-2, FCV-3, FCV-4, FCV-5, FCV-6, FCV-7, FCV-8, FCV-9, FCV-12, FCV-13, FCV-14, FCV-15, FCV-16, FCV-17, FCV-18, FCV-19, FCV-28, FCV-32, FCV-33, LC-50, LC-51, LC-52, LC-53, LC-54, LC-55, LC-59, LC-60, LC-61, LC-62, FCV-34, FCV-38
Vernier Valvactor, Type C	FCV-34A, B, FCV-38A, B, LC-50, LC-51, LC-52, LC-53, LC-54, LC-55, LC-59, LC-60, LC-61, LC-62.
Magnetic Flow Meter, Model 2800, 696A	FT-10, FT-35, <u>FT-36</u> , FT-37.

Notes:

- 5. VAAP Line 1 only

Mercoird Level Switch, Model 401	LS-1, LS-2, LS-3, LS-4, LS-5, LS-6.
Mercoird Level Switch, Model 301	LS-7, LS-9, LS-25.
Magnetrol Level Switch, Model TF-63	LS-8, LS-13, LS-16, LS-17, LS-18, LS-19, LS-21, LS-22.
pH Electrode, pH-to-Current Converter, Model 699	PHT-1, PHT-2, PHT-3, PHT-4
Mercoird Pressure Control, Model DAH-21 and DAH-31	PS-1, PS-2, PS-3, PS-4, PS-5, PS-6, PS-7, PS-8, PS-9, PS-10, PS-11, PS-12, PS-13, PS-14, PS-15, PS-16, PS-18, PS-19.
Mercoird Temperature Control, Model DAH-35	TS-1, TS-2, TS-3, TS-4, TS-5, TS-6, TS-7, TS-8, TS-9, TS-10, TS-11, TS-12, TS-13, TS-14, TS-15, TS-16, TS-17, TS-18, TS-19, TS-20, TS-21, TS-22, TS-23, TS-24, TS-25.
Electro Magnetic Pickup, Model 3075, Frequency Converter, 99V	ST-1, ST-2, ST-3, ST-4, ST-5, ST-6, ST-7, ST-8, ST-9, ST-10.
Dynatherm Resistance Bulb, Model DB-12P, Resistance-to- Current Converter, 694	TT-1, TT-2, TT-3, TT-4, TT-5, TT-6, TT-7, TT-8, TT-9, TT-10, TT-11, TT-12, TT-13, TT-14, TT-15, TT-16, TT-17, TT-18, TT-19, TT-20, TT-21, TT-22, TT-23, TT-41, TT-42, TT-43, TT-44, TT-45, TT-46, TT-47, TT-48, TT-49, TT-50. TT-51, TT-52.
McDonnell FS7-SE Flow Switch	FS-1, FS-2, FS-3, FS-4.

Amplifier Model PA106	ST-1, ST-2, ST-3, ST-4, ST-5, ST-6, ST-7, ST-8, ST-9, ST-10.
Position Transmitter Type CT	LT-50, LT-51, LT-52, LT-53, LT-54, LT-55.
Model 63R Alarm Lines 1, 4, 5, 6	ST-1, ST-2, ST-3, ST-4, ST-5, ST-6, ST-7, ST-8.
Model 63R Alarm * Lines 4, 5, 6 only	AR-2875, AR-2876, AR-2879, AR-2880, AR-2883, AR-2884, AR-2887, AR-2888, AR-2891, AR-2892, AR-2895, AR-2896, AR-2899, AR-2900, AR-2963, AR-2903, AR-2904, AR-2907, AR-2908, AR-2911, AR-2912, AR-2915, AR-2916, AR-2919, AR-2920, AR-2923, AR-2924, AR-2927, AR-2928, AR-2967, AR-2931, AR-2932, AR-2935, AR-2936, AR-2939, AR-2940, AR-2943, AR-2944, AR-2947, AR-2948, AR-2951, AR-2952, AR-2955, AR-2956, AR-2971, AR-2975, AR-2979, AR-2982, AR-2985, AR-2988, AR-2991, AR-2994.
EX-AR or EXD-AR Limit Switch	MV-1, MV-2, MV-4, MV-5, MV-6, MV-8, MV-9, MV-11, MV-12, MV-13, MV-16, MV-17, MV-18, MV-20, MV-21, MV-22, MV-26, MV-27, MV-28, MV-30, MV-31, MV-32, MV-34, MV-35, MV-37, MV-38, MV-39, MV-43, MV-44, MV-45, MV-46, MV-47, MV-48, MV-52, MV-53, MV-54, MV-55, MV-56, MV-57, MV-61, MV-62, MV-63, MV-64, MV-65, MV-66, MV-70, MV-78.

---

\* See Page D-1 for reference to drawing with TAG number identification.

APPENDIX E

LAYAWAY CHECKLIST

DT-1  
to  
DT-8

LAYAWAY CHECKLIST: LINE _____									
TAG NO.	ITEM	MODEL or PART NO.	LOCATION	FLUID	LAYAWAY		REACTIVATE		
					Date: PROCEDURE	Done	Date: PROCEDURE	Done	
DT-1	Differential Pressure Transmitter	E13DL	Separator 1	Acid, Nitrobody	3.3.2.1		3.3.2.4		
DT-2	Buoyancy Level Transmitter	E17BT	Separator 1	Acid, Nitrobody	3.8.4.1		3.8.4.3		
DT-3	Differential Pressure Transmitter	E13DL	Separator 2	Acid, Nitrobody	3.3.2.1		3.3.2.4		
DT-4	Buoyancy Level Transmitter	E17BT	Separator 2	Acid, Nitrobody	3.8.4.1		3.8.4.3		
DT-5	Liquid Level Transmitter	E13DL	Separator 3	Acid, Nitrobody	3.2.1.1		3.2.1.3		
DT-6	Buoyancy Level Transmitter	E17BT	Separator 3	Acid, Nitrobody	3.8.4.1		3.8.4.3		
DT-7	Differential Pressure Transmitter	E13DL	Separator 6	Acid, Nitrobody	3.3.2.1		3.3.2.4		
DT-8	Buoyancy Level Transmitter	E17BT	Separator 6	Acid, Nitrobody	3.8.4.1		3.8.4.3		

ES-2  
to  
ES-16

LAYAWAY CHECKLIST: LINE									
TAG NO.	ITEM	MODEL or PART NO.	LOCATION	FLUID	LAYAWAY		REACTIVATE		
					Date:	PROCEDURE	Date:	PROCEDURE	
ES-2	Limit Switch	4EX-1	Nitrator 1A	--	3.7.1.1	3.7.1.3	3.7.1.3		
ES-3	Limit Switch	EXD-AR800	Nitrator 1A	--	3.7.1.1	3.7.1.3	3.7.1.3		
ES-4	Limit Switch	4EX-1	Nitrator 1B	--	3.7.1.1	3.7.1.3	3.7.1.3		
ES-6	Limit Switch	4EX-1	Nitrator 2	--	3.7.1.1	3.7.1.3	3.7.1.3		
ES-8	Limit Switch	4EX-1	Nitrator 3A	--	3.7.1.1	3.7.1.3	3.7.1.3		
ES-9	Limit Switch	EXD-AR800	Nitrator 3A	--	3.7.1.1	3.7.1.3	3.7.1.3		
ES-10	Limit Switch	4EX-1	Nitrator 3B	--	3.7.1.1	3.7.1.3	3.7.1.3		
ES-12	Limit Switch	4EX-1	Nitrator 4	--	3.7.1.1	3.7.1.3	3.7.1.3		
ES-14	Limit Switch	4EX-1	Nitrator 5	--	3.7.1.1	3.7.1.3	3.7.1.3		
ES-16	Limit Switch	4EX-1	Nitrator 6	--	3.7.1.1	3.7.1.3	3.7.1.3		

NOTE: ES-3 and ES-9 are Limit Switches on the decanter. All other ES Limit Switches are located at the drawn valve.

NOTE: Model Number for VAAP Line 1 is EXD-AR800 for all locations.

FCV-1  
to  
FCV-6

LAYAWAY CHECKLIST: LINE									
TAG NO.	ITEM	MODEL or PART NO.	LOCATION	FLUID	LAYAWAY		REACTIVATE		
					Date:		Date:		
					PROCEDURE	Done	PROCEDURE	Done	
FCV-1	Valve	V1	Nitrator 1A	Toluene	3.1.3.1		3.1.3.4		
	With Actuator	P-25			3.1.7.1		3.1.7.3		
	Solenoid Valve	X-53			3.7.3.1		3.7.3.3		
	Current to Air Transducer	69TA-1							
FCV-2	Valve	V1	Nitrator 1A	WNA	3.1.3.1		3.1.3.4		
	With Actuator	P-25			3.1.7.1		3.1.7.3		
	Solenoid Valve	X-53			3.7.3.1		3.7.3.3		
	Current to Air Transducer	69TA-1							
FCV-3	Valve	V1	Nitrator 1B	WNA	3.1.3.1		3.1.3.4		
	With Actuator	P-25			3.1.7.1		3.1.7.3		
	Solenoid Valve	X-53			3.7.3.1		3.7.3.3		
	Current to Air Transducer	69TA-1							
FCV-4	Valve	V1	Nitrator 2	WNA	3.1.3.1		3.1.3.4		
	With Actuator	P-25			3.1.7.1		3.1.7.3		
	Solenoid Valve	X-53			3.7.3.1		3.7.3.3		
	Current to Air Transducer	69TA-1							
FCV-5	Valve	V1	Nitrator 3A	SNA	3.1.3.1		3.1.3.3		
	With Actuator	P-25			3.1.7.1		3.1.7.3		
	Solenoid Valve	X-53			3.7.3.1		3.7.3.3		
	Current to Air Transducer	69TA-1							
FCV-6	Valve	V1	Nitrator 3B	SNA	3.7.3.1		3.7.3.3		
	With Actuator	P-25			3.1.7.1		3.1.7.3		
	Solenoid Valve	X-53			3.7.3.1		3.7.3.3		
	Current to Air Transducer	69TA-1							

FCV-7  
to  
FCV-13

LAYAWAY CHECKLIST: LINE _____		MODEL or PART NO.		FLUID	LOCATION	LAYAWAY		REACTIVATE			
TAG NO.	ITEM	V1	P-25 X-53 69TA-1			Date: PROCEDURE	Date: PROCEDURE	Done	Done	Date: PROCEDURE	Done
FCV-7	Valve With Actuator Solenoid Valve Current to Air Transducer	V1	P-25 X-53 69TA-1	SNA	Nitrator 4	3.1.3.1	3.1.3.1	3.1.3.4	3.1.3.4		
FCV-8	Valve With Actuator Solenoid Valve Current to Air Transducer	V1	P-25 X-53 69TA-1	SNA	Nitrator 5	3.1.3.1	3.1.3.1	3.1.3.4	3.1.3.4		
FCV-9	Valve With Actuator Solenoid Valve Current to Air Transducer	V1	P-25 X-53 69TA-1	SNA	Nitrator 6	3.1.3.1	3.1.3.1	3.1.3.4	3.1.3.4		
FCV-10	Valve With Actuator Solenoid Valve Current to Air Transducer	V1	P-25 X-53 69TA-1	Oleum	Nitrator 6	3.1.3.1	3.1.3.1	3.1.3.3	3.1.3.3		
FCV-12	Valve With Actuator Solenoid Valve Current to Air Transducer	V1	P-25 X-53 69TA-1	Sellite	Sellite Washer 1	3.1.3.1	3.1.3.1	3.1.3.3	3.1.3.3		
FCV-13	Valve With Actuator Solenoid Valve Current to Air Transducer	V-4A P-50 X-53 69TA-1	P-25 X-53 69TA-1	WNA	Acid Washer	3.1.4.1	3.1.4.1	3.1.4.3	3.1.4.3		

FCV-14  
to  
FCV-18

LAYAWAY CHECKLIST: LINE _____		LAYAWAY				REACTIVATE	
TAG NO.	ITEM	MODEL or PART NO.	LOCATION	FLUID	Date:		Done
					PROCEDURE	PROCEDURE	
FCV-14	Valve	V1	Sellite Washer 2	Sellite (PH 7)	3.1.4.1	3.1.4.3	
	With Actuator Solenoid Valve	P-25 X-53			3.1.7.1 3.7.3.1	3.1.7.3 3.7.3.3	
	Current to Air Transducer	69TA-1					
	Valve	V1*	Penthouse	Process Water	3.1.3.1	3.1.3.4	
FCV-15	With Actuator Solenoid Valve	P-25 X-53			3.1.7.1 3.7.3.1	3.1.7.3 3.7.3.3	
	Current to Air Transducer	69TA-1					
	Valve	V1	Sellite Washer 2	SO <sub>2</sub>	3.1.3.1	3.1.3.4	
	With Actuator Solenoid Valve	P-25 X-53			3.1.7.1 3.7.3.1	3.1.7.3 3.7.3.3	
FCV-16	Current to Air Transducer	69TA-1					
	Valve	V1	Post Sellite Washer	SO <sub>2</sub>	3.1.3.1	3.1.3.4	
	With Actuator Solenoid Valve	P-25 X-53			3.1.7.1 3.7.3.1	3.1.7.3 3.7.3.3	
	Current to Air Transducer	69TA-1					
FCV-17	Valve	V1	Acid Washer	Water	3.1.3.1	3.1.3.4	
	With Actuator Solenoid Valve	P-25 X-53			3.1.7.1 3.7.3.1	3.1.7.3 3.7.3.3	
	Current to Air Transducer	69TA-1					
	Valve	V1					
FCV-18	With Actuator Solenoid Valve	P-50 X-53			3.1.7.1 3.7.3.1	3.1.7.3 3.7.3.3	
	Current to Air Transducer	69TA-1					
	Valve	V-4A					
	With Actuator Solenoid Valve	P-50 X-53			3.1.7.1 3.7.3.1	3.1.7.3 3.7.3.3	

\*To be added by modification.

FCV-19  
to  
FCV-34b

LAYAWAY CHECKLIST: LINE _____		I AWAYWAY		REACTIVATE		
TAG NO.	ITEM	MODEL or PART NO.	LOCATION	FLUID	Date:	
					PROCEDURE	Done
FCV-19	Valve	V-4A	Post Sellite Washer	TNT Water	3.1.4.1	3.1.4.3
	With Actuator	P-25			3.1.7.1	3.1.7.3
	Solenoid Valve	X-53			3.7.3.1	3.7.3.3
	Current to Air Transducer	69TA-1				
FCV-28	Valve	V-4A	Airlift	Air	3.1.4.1	3.1.4.3
	With Actuator	P-50				
	Current to Air Transducer	69TA-1			3.7.3.1	3.7.3.3
FCV-30 (was LCV-9)	Valve	V1	Acid Washer	TNT Water	3.1.3.1	3.1.3.4
	With Actuator	P-25				
	Current to Air Positioner	69PA-1			3.7.2.1	3.7.2.3
FCV-32	Valve	V1	Nitrator 5	Oleum	3.1.3.1	3.1.3.4
	With Actuator	P-25				
	Current to Air Transducer	69TA-1			3.7.3.1	3.7.3.3
FCV-33*	Valve	V1	Nitrator 4	Oleum	3.1.3.1	3.1.3.4
	With Actuator	P-25				
	Current to Air Transducer	69TA-1			3.7.3.1	3.7.3.3
FCV-34a	Valve	V1S	Nitrators 1A and 1B	Toluene	3.1.3.1	3.1.3.4
	Valve	V1S	Nitrators 1A and 1B	Toluene	3.1.3.1	3.1.3.4
FCV-34b	With Actuator	P-25				
	Vernier Valvactor	Type C			3.7.5.1	3.7.5.3
	Current to Air Transducer	69TA-1			3.7.3.1	3.7.3.3
	*Change to FCV-15, Process Water					

FCV-34b  
to  
FCV-38b

LAYAWAY CHECKLIST: LINE		L.AYAWAY		REACTIVATE			
TAG NO.	ITEM	MODEL or PART NO.	LOCATION	FLUID	Date:		
					PROCEDURE	Done	PROCEDURE
FCV-34b (Cont'd)	Fixed Pressure Filter Regulator	V-110-XR			3.8.8.1	3.8.8.3	
FCV-38a	Valve	V1S	Nitrators 1A and 1B	Yellow Water	3.1.3.1	3.1.3.4	
FCV-38b	Valve	V1S	Nitrators 1A and 1B	Yellow Water	3.1.3.1	3.1.3.4	
	With Actuator	P-25			3.7.5.1	3.7.5.3	
	Vernier Valvactor	Type C			3.7.3.1	3.7.3.3	
	Current to Air Transducer	69TA-1			3.8.8.1	3.8.8.3	
	Fixed Pressure Filter Regulator	V-110-XR					

FS-1  
to  
FS-4

LAYAWAY CHECKLIST: LINE		LAYAWAY		REACTIVATE		
TAG NO.	ITEM	MODEL or PART NO.	LOCATION	FLUID	Date:	
					PROCEDURE	Done
FS-1	Flow Switch	FS-7-SE	Fume Scrubber #1	TNT Water Acid	3.6.1.1	3.6.1.3
FS-2	Flow Switch	FS-7-SE	Fume Scrubber #1	TNT Water Acid	3.6.1.1	3.6.1.3
FS-3	Flow Switch	FS-7-SE	TNT Pump Tank	TNT Water	3.6.1.1	3.6.1.3
FS-4	Flow Switch	FS-7-SE	TNT Pump Tank	TNT Water	3.6.1.1	3.6.1.3

FT-1  
to  
FT-6

LAYAWAY CHECKLIST: LINE _____		L.AYAWAY		REACTIVATE		
TAG NO.	ITEM	MODEL or PART NO.	LOCATION	FLUID	Date:	
					PROCEDURE	Done
FT-1	Differential Pressure Transmitter Three Valve Manifold Orifice Plate	E13DM BM-M4VS OPFTT-316-300	Nitrator 1	Toluene	3.3.2.1	3.3.2.4
					3.1.6.1	3.1.6.3
					2.1	
FT-2	Differential Pressure Transmitter Three Valve Manifold Orifice Plate	E13DM BM-M4VS OPFTT-316-300	Nitrator 1	WNA	3.3.2.1	3.3.2.4
					3.1.6.1	3.1.6.3
					2.1	
FT-3	Differential Pressure Transmitter Three Valve Manifold Orifice Plate	E13DM BM-M4VS OPFTT-316-300	Nitrator 1B	WNA	3.3.2.1	3.3.2.4
					3.1.6.1	3.1.6.3
					2.1	
FT-4	Differential Pressure Transmitter Three Valve Manifold Orifice Plate	E13DM BM-M4VS OPFTT-316-300	Nitrator 2	WNA	3.3.2.1	3.3.2.4
					3.1.6.1	3.1.6.3
					2.1	
FT-5	Differential Pressure Transmitter Three Valve Manifold Orifice Plate	E13DM BM-M4VS OPFTT-316-300	Nitrator 3A	SNA	3.3.2.1	3.3.2.4
					3.1.6.1	3.1.6.3
					2.1	
FT-6	Differential Pressure Transmitter Three Valve Manifold Orifice Plate	E13DM BM-M4VS OPFTT-316-300	Nitrator 3B	SNA	3.3.2.1	3.3.2.4
					3.1.6.1	3.1.6.3
					2.1	

FT-7  
to  
FT-12

LAYAWAY CHECKLIST: LINE		LAYAWAY		REACTIVATE		
TAG NO.	ITEM	MODEL or PART NO.	LOCATION	FLUID	Date:	
					PROCEDURE	Done
FT-7	Differential Pressure Transmitter	E13DL	Nitrator 4	SNA	3.3.2.1	3.3.2.4
	By-Pass Manifold	BM-SS-3V			3.1.8.1	3.1.8.3
	Orifice Plate	OP-FTT-316-300			2.1	
FT-8	Differential Pressure Transmitter	E13DL	Nitrator 5	SNA	3.3.2.1	3.3.2.4
	By-Pass Manifold	BM-SS-3V			3.1.8.1	3.1.8.3
	Orifice Plate	OP-FTT-316-300			2.1	
FT-9	Differential Pressure Transmitter	E13DM	Nitrator 6	SNA	3.3.2.1	3.3.2.4
	Three Valve Manifold	BM-MAVS			3.1.6.1	3.1.6.3
	Orifice Plate	OPFTT-316-300			2.1	
FT-10	Magnetic Flow Meter	2800	Penthouse	Oilcum	3.6.2.1	3.6.2.3
	Magnetic Flow-to-Current Converter	696A	Hydraulic Pump House		3.5.3.1	3.5.3.3
FT-11	Differential Pressure Transmitter	E13DM	Separator 3	Yellow Water, Nitrobody	3.3.2.1	3.3.2.4
	By-Pass Manifold	BM-SS-3V			3.1.8.1	3.1.8.3
	Orifice Plate	OPFTT-316-300			2.1	
FT-12	Differential Pressure Transmitter	E13DL	Sellite Washer #1	Sellite	3.3.2.1	3.3.2.4
	By-Pass Manifold	BM-SS-3V			3.1.8.1	3.1.8.3
	Orifice Plate	OPFTT-316-300			2.1	

FT-13  
to  
FT-18

LAYAWAY CHECKLIST: LINE		REACTIVATE									
TAG NO.	ITEM	MODEL or PART NO.	LOCATION	FLUID	LAYAWAY		REACTIVATE		Date:		
					PROCEDURE	Done	PROCEDURE	Done	PROCEDURE	Done	
FT-13	Differential Pressure Transmitter Include (With Integral Orifice)	E13DM	Acid Washer	WNA	3.3.2.1		3.3.2.4		3.3.2.4		
FT-14	Differential Pressure Transmitter	E13DM	Sellite Washer 2	Sellite (PH 9)	3.3.2.1		3.3.2.4		3.3.2.4		
	By-Pass Manifold Orifice Plate	BM-M4VS OPFTT-316-300			3.1.6.1 2.1		3.1.6.3		3.1.6.3		
FT-15	Differential Pressure Transmitter	E13DM	Nitrator 4	Process Water	3.3.2.2		3.3.2.4		3.3.2.4		
	By-Pass Manifold Orifice Plate	BM-M4VS OPFTT-316-300			3.1.6.1 2.1		3.1.6.3		3.1.6.3		
FT-16	Differential Pressure Transmitter	E13DM	Sellite Washer 2	SO <sub>2</sub>	3.3.2.1		3.3.2.4		3.3.2.4		
	By-Pass Manifold Orifice Plate	BM-M4VS OPFTT-316-300			3.1.6.1 2.1		3.1.6.3		3.1.6.3		
FT-17	Differential Pressure Transmitter	E13DM	Post Sellite Washer	SO <sub>2</sub>	3.3.2.1		3.3.2.4		3.3.2.4		
	By-Pass Manifold Orifice Plate	BM-M4VS OPFTT-316-300			3.1.6.1 2.1		3.1.6.3		3.1.6.3		
FT-18	Differential Pressure Transmitter	E13DM	Acid Washer	Water	3.3.2.2		3.3.2.4		3.3.2.4		
	By-Pass Manifold Orifice Plate	BM-M4VS OPFTT-316-300			3.1.6.1 2.1		3.1.6.3		3.1.6.3		

FT-19  
to  
FT-24

LAYAWAY CHECKLIST: LINE _____									
TAG NO.	ITEM	MODEL or PART NO.	LOCATION	FLUID	LAYAWAY		REACTIVATE		Date:
					PROCEDURE	Done	PROCEDURE	Done	
FT-19	Differential Pressure Transmitter	E13DH	Post Sellite Washer	TNT Water	3.3.2.1		3.3.2.4		
	By-Pass Manifold	BM-M4VS			3.1.6.1		3.1.6.3		
	Orifice Plate	OPFTT-316-300			2.1				
FT-20	Differential Pressure Transmitter	E13DM	Nitrator 1A	Water	3.3.2.2		3.3.2.4		
	By-Pass Manifold	BM-M4VS			3.1.6.1		3.1.6.3		
	Orifice Plate	OPFTT-316-300			2.1				
FT-21	Differential Pressure Transmitter	E13DM	Nitrator 1B	Water	3.3.2.2		3.3.2.4		
	By-Pass Manifold	BM-M4VS			3.1.6.1		3.1.6.3		
	Orifice Plate	OPFTT-316-300			2.1				
FT-22	Differential Pressure Transmitter	E13DM	Nitrator 2	Water	3.3.2.2		3.3.2.4		
	By-Pass Manifold	BM-M4VS			3.1.6.1		3.1.6.3		
	Orifice Plate	OPFTT-316-300			2.1				
FT-23	Differential Pressure Transmitter	E13DM	Nitrator 3A	Water	3.3.2.2		3.3.2.4		
	By-Pass Manifold	BM-M4VS			3.1.6.1		3.1.6.3		
	Orifice Plate	OPFTT-316-300			2.1				
FT-24	Differential Pressure Transmitter	E13DH	Nitrator 3B	Water	3.3.2.2		3.3.2.4		
	By-Pass Manifold	BM-M4VS			3.1.6.1		3.1.6.3		
	Orifice Plate	OPFTT-316-300			2.1				

FT-25  
to  
FT-30

LAYAWAY CHECKLIST: LINE									
TAG NO.	ITEM	MODEL or PART NO.	LOCATION	FLUID	LAYAWAY		REACTIVATE		
					PROCEDURE		Date:		
					Done	Done	PROCEDURE	Done	
FT-25	Differential Pressure Transmitter	E13DM	Nitrator 4	Water	3.3.2.2		3.3.2.4		
	By-Pass Manifold	BM-M4VS			3.1.6.1		3.1.6.3		
	Orifice Plate	OP FTT-316-300			2.1				
FT-26	Differential Pressure Transmitter	E13DM	Nitrator 5	Water	3.3.2.2		3.3.2.4		
	By-Pass Manifold	BM-M4VS			3.1.6.1		3.1.6.3		
	Orifice Plate	OP FTT-316-300			2.1				
FT-27	Differential Pressure Transmitter	E13DM	Nitrator 6	Water	3.3.2.2		3.3.2.4		
	By-Pass Manifold	BM-M4VS			3.1.6.1		3.1.6.3		
	Orifice Plate	OP FTT-316-300			2.1				
FT-28	Differential Pressure Transmitter	E13DM	Airlift	Air	3.3.2.2		3.3.2.4		
	By-Pass Manifold	BM-M4VS			3.1.6.1		3.1.6.3		
	Orifice Plate	OP FTT-316-300			2.1				
FT-29	Differential Pressure Transmitter	E13DM	Spent Acid Settling Tank	Spent Acid	3.3.2.1		3.3.2.4		
	By-Pass Manifold	BM-M4VS			3.1.6.1		3.1.6.3		
	Orifice Plate	OP FTT-316-300			2.1				
FT-30	Differential Pressure Transmitter	E13DM	Acid Washer	Red Water	3.3.2.1		3.3.2.4		
	By-Pass Manifold	BM-M4VS			3.1.6.1		3.1.6.3		
	Orifice Plate	OP FTT-316-300			2.1				

FT-32  
to  
FT-37

LAYAWAY CHECKLIST: LINE		REACTIVATE									
TAG NO.	ITEM	MODEL or PART NO.	LOCATION	FLUID	LAYAWAY		Date:		PROCEDURE		Done
					PROCEDURE	Done	PROCEDURE	Done	PROCEDURE	Done	
FT-32*	Differential Pressure Transmitter By-Pass Manifold Orifice Plate	E13DM BM-M4VS OPFTT-316-300	Nitrator 5	Oleum	3.3.2.1 3.1.6.1 2.1		3.3.2.4 3.1.6.3				
FT-33*	Differential Pressure Transmitter By-Pass Manifold Orifice Plate	E13DM BM-M4VS OPFTT-316-300	Nitrator 4	Oleum	3.3.2.1 3.1.6.1 2.1		3.3.2.4 3.1.6.3				
FT-34	Differential Pressure Transmitter By-Pass Manifold Orifice Plate	E13DM BM-M4VS OPFTT-316-300	Nitrator 1	Toluene	3.3.2.1 3.1.6.1 2.1		3.3.2.4 3.1.6.3				
FT-35	Magnetic Flow Meter Magnetic Flow to Current Converter	2800 696A	Separator 2** Hydraulic Pump House	Spent Acid	3.6.2.1 3.5.3.1		3.6.2.3 3.5.3.3				
FT-36	Magnetic Flow Meter Magnetic Flow to Current Converter	2800 696A	Separator 3** Hydraulic Pump House	Spent Acid	3.6.2.1 3.5.3.1		3.6.2.3 3.5.3.3				
FT-37	Magnetic Flow Meter Magnetic Flow to Current Converter	2800 696A	Separator 4** Hydraulic Pump House	Spent Acid	3.6.2.1 3.5.3.1		3.6.2.3 3.5.3.3				
	*To be removed by modification. **Line 1 only at VAAP.										

LAYAWAY CHECKLIST: LINE _____									
TAG NO.	ITEM	MODEL OF PART NO.	LOCATION	FLUID	LAYAWAY		REACTIVATE		
					PROCEDURE	Date:	PROCEDURE	Date:	
FT-38	Differential Pressure Transmitter	E13DM	Nitrator 2	Yellow Water	3.3.2.1		3.3.2.4		
	By-Pass Manifold	BM-M4VS			3.1.6.1		3.1.6.3		
	Orifice Plate	OPFTT-316-300			2.1				

LC-50  
to  
LC-59

LAYAWAY CHECKLIST: LINE		LAYAWAY				REACTIVATE	
TAG NO.	ITEM	MODEL or PART NO.	LOCATION	FLUID	Date:		Done
					PROCEDURE	PROCEDURE	
LC-50	Current to Air Transducer Vernier Valvactor With Actuator	69TA-1 Type C P-50	Separator 1	--	3.7.3.1	3.7.3.3	
					3.7.5.1	3.7.5.3	
LC-51	Current to Air Transducer Vernier Valvactor With Actuator	69TA-1 Type C P-50	Separator 2	--	3.7.3.1	3.7.3.3	
					3.7.5.1	3.7.5.3	
LC-52	Current to Air Transducer Vernier Valvactor With Actuator	69TA-1 Type C P-50	Separator 3	--	3.7.3.1	3.7.3.3	
					3.7.5.1	3.7.5.3	
LC-53	Current to Air Transducer Vernier Valvactor With Actuator	69TA-1 Type C P-50	Separator 4	--	3.7.3.1	3.7.3.3	
					3.7.5.1	3.7.5.3	
LC-54	Current to Air Transducer Vernier Valvactor With Actuator	69TA-1 Type C P-50	Separator 5	--	3.7.3.1	3.7.3.3	
					3.7.5.1	3.7.5.3	
LC-55	Current to Air Transducer Vernier Valvactor With Actuator	69TA-1 Type C P-50	Separator 6	--	3.7.3.1	3.7.3.3	
					3.7.5.1	3.7.5.3	
LC-59	Current to Air Transducer Vernier Valvactor With Actuator	69TA-1 Type C P-50	Acid Washer	--	3.7.3.1	3.7.3.3	
					3.7.5.1	3.7.5.3	

LC-60  
to  
LC-62

LAYAWAY CHECKLIST: LINE		LAYAWAY		REACTIVATE				
TAG NO.	ITEM	MODEL or PART NO.	LOCATION	FLUID	LAYAWAY		REACTIVATE	
					Date:	PROCEDURE	Done	Date:
LC-60	Current to Air Transducer Vernier Valvactor With Actuator	69TA-1 Type C P-50	Sellite Separator 1	--	3.7.3.1		3.7.3.3	
					3.7.5.1		3.7.5.3	
LC-61	Current to Air Transducer Vernier Valvactor With Actuator	69TA-1 Type C P-50	Sellite Separator 2	--	3.7.3.1		3.7.3.3	
					3.7.5.1		3.7.5.3	
LC-62	Current to Air Transducer Vernier Valvactor With Actuator	69TA-1 Type C P-50	Post Sellite Washer Decanter	--	3.7.3.1		3.7.3.3	
					3.7.5.1		3.7.5.3	

LCV-1  
to  
LCV-5

LAYAWAY CHECKLIST: LINE		ITEM	MODEL or PART NO.	LOCATION	FLUID	LAYAWAY		REACTIVATE		
TAG NO.	Date:					PROCEDURE	Done	Date:	PROCEDURE	Done
LCV-1		Valve	V1	Toluene Day Tank	Toluene	3.1.3.1		3.1.3.4		
		With Actuator Solenoid Valve	P-25 X-53			3.1.7.1		3.1.7.3		
		Current to Air Positioner	69PA-1			3.7.2.1		3.7.2.3		
		Valve	V1	Oleum Day Tank	Oleum	3.1.3.1		3.1.3.4		
LCV-2		With Actuator Solenoid Valve	P-50 X-53			3.1.7.1		3.1.7.3		
		Current to Air Positioner	69PA-1			3.7.2.1		3.7.2.3		
		Valve	V-4A Line 1 (V-1 All others)	SNA Day Tank	SNA	3.1.4.1 (3.1.3.1)		3.1.4.3 (3.1.3.4)		
		With Actuator Solenoid Valve	P-50 X-53			3.1.7.1		3.1.7.3		
LCV-3		Current to Air Positioner	69PA-1			3.7.2.1		3.7.2.3		
		Valve	V-4A Line 1 (V-1 All others)	WNA Day Tank	WNA	3.1.4.1 (3.1.3.1)		3.1.4.3 (3.1.3.4)		
		With Actuator Solenoid Valve	P-50 X-53			3.1.7.1		3.1.7.3		
		Current to Air Positioner	69PA-1			3.7.2.1		3.7.2.3		
LCV-4		Valve	V-4A Line 1 (V-1 All others)	PH 7 Sellite Tank	Sellite	3.1.4.1 (3.1.3.1)		3.1.4.3 (3.1.3.4)		
		With Actuator Solenoid Valve	P-50 X-53			3.1.7.1		3.1.7.3		
		Current to Air Positioner	69PA-1			3.7.2.1		3.7.2.3		
		Valve	V-4A Line 1 (V-1 All others)	PH 7 Sellite Tank	Sellite	3.1.4.1 (3.1.3.1)		3.1.4.3 (3.1.3.4)		
LCV-5		With Actuator Solenoid Valve	P-50 X-53			3.1.7.1		3.1.7.3		
		Current to Air Positioner	69PA-1			3.7.2.1		3.7.2.3		
		Valve	V-4A Line 1 (V-1 All others)	PH 7 Sellite Tank	Sellite	3.1.4.1 (3.1.3.1)		3.1.4.3 (3.1.3.4)		
		With Actuator Solenoid Valve	P-50 X-53			3.1.7.1		3.1.7.3		
	Current to Air Positioner	69PA-1			3.7.2.1		3.7.2.3			

LCV-6  
to  
LCV-12

LAYAWAY CHECKLIST: LINE		REACTIVATE									
TAG NO.	ITEM	MODEL or PART NO.	LOCATION	FLUID	LAYAWAY		REACTIVATE				
					Date:	PROCEDURE	Date:	PROCEDURE			
LCV-6	Valve	V-4A Line 1	PH 9	Sellite	3.1.4.1	3.1.4.3					
	With Actuator	(V-1 All others)	Sellite Tank		(3.1.3.1)	(3.1.3.4)					
	Solenoid Valve	P-50									
LCV-7	Current to Air Positioner	X-53			3.1.7.1	3.1.7.3					
	Valve	69PA-1			3.7.2.1	3.7.2.3					
	With Actuator	V1	Spent Acid Tank	Spent Acid	3.1.3.1	3.1.3.4					
LCV-8	Current to Air Positioner	P-50			3.7.2.1	3.7.2.3					
	Valve	69PA-1	Yellow Water Pump Tank	Yellow Water	3.1.3.1	3.1.3.4					
	With Actuator	Pum									
LCV-10	Current to Air Positioner	P-25			3.7.2.1	3.7.2.3					
	Valve	69PA-1	Recycle Water Tank	Water, TNT	3.1.4.1	3.1.4.3					
	With Actuator	V-4A									
LCV-11	Current to Air Positioner	P-50			3.7.2.1	3.7.2.3					
	Valve	69PA-1	TNT Pump Tank	TNT	3.1.3.1	3.1.3.4					
	With Actuator	V1									
LCV-12	Current to Air Positioner	P-50			3.7.2.1	3.7.2.3					
	Valve	69PA-1	Spent Acid Settling Tank	Spent Acid	3.1.3.1	3.1.3.4					
	With Actuator	V1									
LCV-12	Current to Air Positioner	P-50			3.7.2.1	3.7.2.3					
	Valve	69PA-1			3.7.2.1	3.7.2.3					
	With Actuator	V1									

LCV-39  
to  
LCV-42

LAYAWAY CHECKLIST: LINE									
TAG NO.	ITEM	MODEL OR PART NO.	LOCATION	FLUID	LAYAWAY		REACTIVATE		Date:
					PROCEDURE	Done	PROCEDURE	Done	
LCV-39	Valve	V9000	Casual Water Pump Tank	Water, Acid, Nitrobody	3.1.5.1		3.1.5.3		
	With Actuator Solenoid Valve	P-50 X-53			3.1.7.1		3.1.7.3		
	Valve	V1	Red Water Pump Tank	Red Water	3.1.3.1		3.1.3.4		
LCV-40	With Actuator Current to Air Positioner	P-25 69PA-1			3.7.2.1		3.7.2.3		
	Valve	V-9000	Acid Water Pump Tank	Acid Nitrobody, Water	3.1.5.1		3.1.5.3		
	With Actuator Solenoid Valve	P-50 X-53			3.1.7.1		3.1.7.3		
LCV-41	Valve	V-9000	Acid Water Pump Tank	Acid Nitrobody, Water	3.1.5.1		3.1.5.3		
	With Actuator Solenoid Valve	P-50 X-53			3.1.7.1		3.1.7.3		
	Valve	V-9000	Acid Water Pump Tank	Acid Nitrobody, Water	3.1.5.1		3.1.5.3		
LCV-42	With Actuator Solenoid Valve	P-50 X-53			3.1.7.1		3.1.7.3		
	Valve	V-9000	Acid Water Pump Tank	Acid Nitrobody, Water	3.1.5.1		3.1.5.3		
	With Actuator Solenoid Valve	P-50 X-53			3.1.7.1		3.1.7.3		

LS-1  
to  
LS-18

LAYAWAY CHECKLIST: LINE		ITEM		MODEL or PART NO.	LOCATION	FLUID	LAYAWAY		REACTIVATE	
TAG NO.	ITEM	Date:	PROCEDURE				Date:	PROCEDURE	Done	Done
LS-1	Mercoid Level Switch	401-1E	Toluene Day Tank	Toluene	3.2.3.1	3.2.3.3				
LS-2	Mercoid Level Switch	401-1E	Oleum Day Tank	Toluene	3.2.3.1	3.2.3.3				
LS-3	Mercoid Level Switch	401-1E	SNA Day Tank	Toluene	3.2.3.1	3.2.3.3				
LS-4	Mercoid Level Switch	401-1E	WNA Day Tank	Toluene	3.2.3.1	3.2.3.3				
LS-5	Mercoid Level Switch	401-1E	PH 7 Sellite Tank	Toluene	3.2.3.1	3.2.3.3				
LS-6	Mercoid Level Switch	401-1E	PH 9 Sellite Tank	Toluene	3.2.3.1	3.2.3.3				
LS-7	Mercoid Level Switch	301-E	Spent Acid Tank	Spent Acid	3.2.3.1	3.2.3.3				
LS-8	Magnetrol Level Switch	TF-63	Yellow Water Transfer Pump Tank	Yellow Water	3.2.2.1	3.2.2.3				
LS-9	Mercoid Level Switch	301-E	TNT Pump Tank	TNT	3.2.3.1	3.2.3.3				
LS-13	Magnetrol Level Switch	TF-63	Catch Tank	TNT Water	3.2.2.1	3.2.2.3				
LS-16	Magnetrol Level Switch	TF-63	Casual Water Pump Tank	TNT Water	3.2.2.1	3.2.2.3				
LS-17	Magnetrol Level Switch	TF-63	Red Water Pump Tank	TNT Water	3.2.2.1	3.2.2.3				
LS-18	Magnetrol Level Switch	TF-63	Acid Water Tank	TNT Water	3.2.2.1	3.2.2.3				

LS-19  
to  
LS-25

LAYAWAY CHECKLIST: LINE		MODEL or PART NO.		FLUID	LAYAWAY		REACTIVATE	
TAG NO.	ITEM	LOCATION	FLUID		Date: PROCEDURE	Done	Date: PROCEDURE	Done
LS-19	Magnetrol Level Switch	Yellow Water Transfer Pump Tank	TF-63	TNT Water	3.2.2.1		3.2.2.3	
LS-20	This is a level switch which controls a sump pump in the settling tank area. drain any rain water which may accumulate.			This switch will not be layed away. It must remain active to				
LS-21	Magnetrol Level Switch	Sellite Separator 1	TF-63	Sellite and Nitrobody	3.2.2.1		3.2.2.3	
LS-22	Magnetrol Level Switch	Sellite Separator 2	TF-63	Sellite and Nitrobody	3.2.2.1		3.2.2.3	
LS-23 LS-24	NOTE: Removed by modification.							
LS-25	Magnetrol Level Switch	Scrubber Water Recirculation Tank	301-E	TNT	3.2.3.1		3.2.3.3	

LT-1  
to  
LT-12

TAG NO.	ITEM	MODEL or PART NO.	LOCATION	FLUID	LAYAWAY		REACTIVATE	
					Date:	Done	Date:	Done
					PROCEDURE		PROCEDURE	
LT-1	Liquid Level Transmitter	E17DM	Toluene Day Tank	Toluene	3.2.1.1		3.2.1.3	
LT-2	Liquid Level Transmitter	E17DM	Oleum Day Tank	Oleum	3.2.1.1		3.2.1.3	
LT-3	Liquid Level Transmitter	E17DM	SNA Day Tank	SNA	3.2.1.1		3.2.1.3	
LT-4	Liquid Level Transmitter	E17DM	WNA Day Tank	WNA	3.2.1.1		3.2.1.3	
LT-5	Liquid Level Transmitter	E17DM	PH 7 Sellite Tank	Sellite	3.2.1.1		3.2.1.3	
LT-6	Liquid Level Transmitter	E17DM	PH 9 Sellite Tank	Sellite	3.2.1.1		3.2.1.3	
LT-7	Liquid Level Transmitter	E17DM	Spent Acid Tank	Spent Acid	3.2.1.1		3.2.1.3	
LT-8	Liquid Level Transmitter	E17DM	Yellow Water Pump Tank	Water, Acid, Nitrobody	3.2.1.1		3.2.1.3	
LT-9	Liquid Level Transmitter	E17DM	Post Sellite Wash Water Tank	Water, Nitrobody	3.2.1.1		3.2.1.3	
LT-10	Liquid Level Transmitter	E17DM	Recycle Water Tank	Water, TNT	3.2.1.1		3.2.1.3	
LT-11	Liquid Level Transmitter	E17DM	TNT Pump Tank	Water, TNT	3.2.1.1		3.2.1.3	
LT-12	Liquid Level Transmitter	E17DM	Spent Acid Settling Tank	Spent Acid	3.2.1.1		3.2.1.3	

LT-39  
to  
LT-57

LAYAWAY CHECKLIST: LINE									
TAG NO.	ITEM	MODEL or PART NO.	LOCATION	FLUID	LAYAWAY		REACTIVATE		
					PROCEDURE	Done	PROCEDURE	Done	
					Date:		Date:		
LT-39	Pressure Transmitter	13FA	Casual Water Pump Tank	Water, Acid, Nitrobody	3.3.3.1		3.3.3.3		
LT-40	Liquid Level Transmitter	E17DM	Red Water Pump Tank	Water, Nitrobody	3.2.1.1		3.2.1.3		
LT-41	Pressure Transmitter	13FA	Acid Water Pump Tank	Acid, Water	3.3.3.1		3.3.3.3		
LT-42	Pressure Transmitter	13FA	Yellow Water Transfer Pump Tank	Water, Acid, Nitrobody	3.3.3.1		3.3.3.3		
LT-50	Pressure Transmitter	E11GM	Separator 1	--	3.3.1.1		3.3.1.3		
LT-51	Position Transmitter	Type CP	Separator 2	--	3.7.4.1		3.7.4.3		
LT-52	Pressure Transmitter	E11GM	Separator 3	--	3.3.1.1		3.3.1.3		
LT-53	Position Transmitter	Type CP	Separator 4	--	3.7.4.1		3.7.4.3		
LT-54	Pressure Transmitter	E11GM	Separator 5	--	3.3.1.1		3.3.1.3		
LT-55	Position Transmitter	Type CP	Separator 6	--	3.7.4.1		3.7.4.3		
LT-56	Buoyancy Level Transmitter	E17BT	Airlift	Nitrobody	3.3.1.1		3.3.1.3		
LT-57	Liquid Level Transmitter	E17DL	Acid Washer	Acid, Nitrobody	3.7.4.1		3.7.4.3		
					3.8.4.1		3.8.4.3		
					3.2.1.1		3.2.1.3		

L.T-58  
to  
L.T-64

LAYAWAY CHECKLIST: LINE TAG NO.	ITEM	MODEL or PART NO.	LOCATION	FLUID	LAYAWAY		REACTIVATE	
					Date: PROCEDURE	Done	Date: PROCEDURE	Done
L.T-58	Liquid Level Transmitter	E17DL	Post Sellite Washer	Sellite	3.2.1.1		3.2.1.3	
L.T-63	Liquid Level Transmitter	E17DL	Sellite Separator 1	Nitrobody	3.2.1.1		3.2.1.3	
L.T-64	Liquid Level Transmitter	E17DL	Sellite Separator 2	Nitrobody	3.2.1.1		3.2.1.3	

MV-1  
to  
MV-5

LAYAWAY CHECKLIST: LINE		LAYAWAY				REACTIVATE	
TAG NO.	ITEM	MODEL or PART NO.	LOCATION	FLUID	Date:		Done
					PROCEDURE	Done	
MV-1	Valve	V9000	Nitrator 1A	Oleum, Nitrobody	3.1.5.1		3.1.5.3
	Actuator	P-50			3.1.7.1		3.1.7.3
	Solenoid Valve	X-53			3.7.1.1		3.7.1.3
	Limit Switch	EX-AR or EXD-AR					
MV-2	Valve	V4A	Nitrator 1A	Water, Nitrobody	3.1.4.1		3.1.4.3
	With Actuator	P-50			3.1.7.1		3.1.7.3
	Solenoid Valve	X-53			3.7.1.1		3.7.1.3
	Limit Switch	EX-AR or EXD-AR					
MV-3	Valve	V1	Nitrator 1A	Hydraulic Oil	3.1.3.2		3.1.3.4
	With Actuator	P-50			3.1.7.1		3.1.7.3
	Solenoid Valve	X-53			3.1.5.1		3.1.5.3
MV-4	Valve	V9000	Nitrator 1A	Steam	3.1.7.1		3.1.7.3
	With Actuator	P-50			3.1.7.1		3.1.7.3
	Solenoid Valve	X-53			3.7.1.1		3.7.1.3
	Limit Switch	EX-AR or EXD-AR					
MV-5	Valve	V1	Nitrator 1A	Water	3.1.3.1		3.1.3.4
	With Actuator	P-50			3.1.7.1		3.1.7.3
	Solenoid Valve	X-53			3.7.1.1		3.7.1.3
	Limit Switch	EX-AR or EXD-AR					

MV-6  
to  
MV-11

LAYAWAY CHECKLIST: LINE _____									
TAG NO.	ITEM	MODEL or PART NO.	LOCATION	FLUID	LAYAWAY		REACTIVATE		Date:
					PROCEDURE	Done	PROCEDURE	Done	
MV-6	Valve	V1	Nitrator 1A	Steam	3.1.3.1		3.1.3.4		
	With Actuator	P-50							
	Solenoid Valve	X-53			3.1.7.1		3.1.7.3		
	Limit Switch	EX-AR or EXD-AR			3.7.1.1		3.7.1.3		
MV-7	Solenoid Valves	X-53, X-55	Nitrator 1A	Air	3.1.7.1		3.1.7.3		
	Valve	V9000	Nitrator 1B	Oleum	3.1.5.1		3.1.5.3		
MV-8	With Actuator	P-50							
	Solenoid Valve	X-53			3.1.7.1		3.1.7.3		
	Limit Switch	EX-AR or EXD-AR			3.7.1.1		3.7.1.3		
	Valve	V4A	Nitrator 1B	Water, Nitrobody	3.1.4.1		3.1.4.3		
MV-9	With Actuator	P-50							
	Solenoid Valve	X-53			3.1.7.1		3.1.7.3		
	Limit Switch	EX-AR or EXD-AR			3.7.1.1		3.7.1.3		
	Valve	V1	Nitrator 1B	Hydraulic Oil	3.1.3.2		3.1.3.4		
MV-10	With Actuator	P-50							
	Solenoid Valve	X-53			3.1.7.1		3.1.7.3		
MV-11	Valve	V9000	Nitrator 1B	Steam	3.1.5.1		3.1.5.3		
	With Actuator	P-50							
	Solenoid Valve	X-53			3.1.7.1		3.1.7.3		
	Limit Switch	EX-AR or EXD-AR			3.7.1.1		3.7.1.3		

MV-12  
to  
MV-17

LAYAWAY CHECKLIST: LINE									
TAG NO.	ITEM	MODEL or PART NO.	LOCATION	FLUID	LAYAWAY		REACTIVATE		Done
					PROCEDURE	Date:	PROCEDURE	Date:	
MV-12	Valve	V1	Nitrator 1B	Water	3.1.3.1		3.1.3.4		
	With Actuator	P-50							
	Solenoid Valve	X-53			3.1.7.1		3.1.7.3		
	Limit Switch	EX-AR or EXD-AR			3.7.1.1		3.7.1.3		
MV-13	Valve	V1	Nitrator 1B	Water	3.1.3.1		3.1.3.4		
	With Actuator	P-50							
	Solenoid Valve	X-53			3.1.7.1		3.1.7.3		
	Limit Switch	EX-AR or EXD-AR			3.7.1.1		3.7.1.3		
MV-14	Solenoid Valves	X-53, X-55	Nitrator 1B	Air	3.1.7.1		3.1.7.3		
MV-15	Valve	V9000	Separator 1	Water	3.1.5.1		3.1.5.3		
	With Actuator	P-50							
	Solenoid Valve	X-53			3.1.7.1		3.1.7.3		
MV-16	Valve	V1	Yellow Pump Tank	Hydraulic Oil	3.1.3.2		3.1.3.4		
	With Actuator	P-50							
	Solenoid Valve	X-53			3.1.7.1		3.1.7.3		
	Limit Switch	EX-AR or EXD-AR			3.7.1.1		3.7.1.3		
	Valve	V9000	Nitrator 2	Oleum	3.1.5.1		3.1.5.3		
MV-17	With Actuator	P-50							
	Solenoid Valve	X-53			3.1.7.1		3.1.7.3		
	Limit Switch	EX-AR or EXD-AR			3.7.1.1		3.7.1.3		

MV-18  
to  
MV-22

LAYAWAY CHECKLIST: LINE TAG NO.	ITEM	MODEL or PART NO.	LOCATION	FLUID	LAYAWAY		REACTIVATE	
					Date:		Date:	
					PROCEDURE	Done	PROCEDURE	Done
MV-18	Valve	V4A	Nitrator 2	Water, Nitrobody	3.1.3.1		3.1.3.4	
	With Actuator	P-110			3.1.7.1		3.1.7.3	
	Solenoid Valve	X-53			3.7.1.1		3.7.1.3	
	Limit Switch	EX-AR or EXD-AR						
MV-19	Valve	V1	Nitrator 2	Hydraulic Oil	3.1.3.2		3.1.3.4	
	With Actuator Solenoid Valve	P-50 X-53			3.1.7.1		3.1.7.3	
MV-20	Valve	V1	Nitrator 2	Water	3.1.3.1		3.1.3.4	
	With Actuator	P-50			3.1.7.1		3.1.7.3	
	Solenoid Valve	X-53			3.7.1.1		3.7.1.3	
	Limit Switch	EX-AR or EXD-AR						
MV-21	Valve	V1	Nitrator 2	Water	3.1.3.1		3.1.3.4	
	With Actuator	P-50			3.1.7.1		3.1.7.3	
	Solenoid Valve	X-53			3.7.1.1		3.7.1.3	
	Limit Switch	EX-AR or EXD-AR						
MV-22	Valve	V9000	Nitrator 2	Water	3.1.5.1		3.1.5.3	
	With Actuator	P-50			3.1.7.1		3.1.7.3	
	Solenoid Valve	X-53			3.7.1.1		3.7.1.3	
	Limit Switch	EX-AR or EXD-AR						

MV-23  
to  
MV-28

LAYAWAY CHECKLIST: LINE _____		I LAYAWAY		REACTIVATE		
TAG NO.	ITEM	MODEL or PART NO.	LOCATION	FLUID	Date:	
					PROCEDURE	Done
MV-23	Solenoid Valves	X-53, X-55	Nitrator 2	Air	3.1.7.1	3.1.7.3
MV-24	Valve With Actuator Solenoid Valve	V9000 P-50 X-53	Separator 2	Water	3.1.5.1	3.1.5.3
MV-25	Valve With Actuator Solenoid Valve	V9000 P-50 X-53	Separator 2	Steam	3.1.7.1	3.1.7.3
MV-26	Valve With Actuator Solenoid Valve Limit Switch	F45 (VAAP - Line 1) (V5310 others) P-25 X-53 EX-AR or EXD-AR	Separator 2	Steam	3.1.7.1	3.1.7.3
MV-27	Valve With Actuator Solenoid Valve Limit Switch	V9000 P-50 X-53 EX-AR or EXD-AR	Nitrator 3A	Oleum	3.1.5.1	3.1.5.3
MV-28	Valve With Actuator Solenoid Valve Limit Switch	V4A P-50 X-53 EX-AR or EXD-AR	Nitrator 3A	Water, Nitrobody	3.1.4.1	3.1.4.3

MV-29  
to  
MV-34

LAYAWAY CHECKLIST: LINE		LAYAWAY				REACTIVATE	
TAG NO.	ITEM	MODEL or PART NO.	LOCATION	FLUID	Date:		Done
					PROCEDURE	PROCEDURE	
MV-29	Valve	V1	Nitrator 3A	Hydraulic Oil	3.1.3.2	3.1.3.4	
	With Actuator	P-110			3.1.7.1	3.1.7.3	
	Solenoid Valve	X-53			3.7.1.1	3.7.1.3	
	Limit Switch	EX-AR or EXD-AR					
MV-30	Valve	V1	Nitrator 3A	Water	3.1.3.1	3.1.3.4	
	With Actuator	P-50			3.1.7.1	3.1.7.3	
	Solenoid Valve	X-53			3.7.1.1	3.7.1.3	
	Limit Switch	EX-AR or EXD-AR					
MV-31	Valve	V9000	Nitrator 3A	Water	3.1.5.1	3.1.5.3	
	With Actuator	P-50			3.1.7.1	3.1.7.3	
	Solenoid Valve	X-53			3.7.1.1	3.7.1.3	
	Limit Switch	EX-AR or EXD-AR					
MV-32	Valve	V9000	Nitrator 3A	Steam	3.1.5.1	3.1.5.3	
	With Actuator	P-50			3.1.7.1	3.1.7.3	
	Solenoid Valve	X-53			3.7.1.1	3.7.1.3	
	Limit Switch	EX-AR or EXD-AR					
MV-33	Solenoid Valves	X-53, X-55	Nitrator 3A	Air	3.1.7.1	3.1.7.3	
	Valve	V9000	Nitrator 3B		3.1.5.1	3.1.5.3	
	With Actuator	P-50			3.1.7.1	3.1.7.3	
	Solenoid Valve	X-53			3.7.1.1	3.7.1.3	
MV-34	Limit Switch	EX-AR or EXD-AR		Oleum			
	Valve	V9000			3.1.5.1	3.1.5.3	
	With Actuator	P-50			3.1.7.1	3.1.7.3	
	Solenoid Valve	X-53			3.7.1.1	3.7.1.3	

MV-35  
to  
MV-39

LAYAWAY CHECKLIST: LINE _____		REACTIVATE				
TAG NO.	ITEM	MODEL or PART NO.	LOCATION	FLUID	LAYAWAY	
					PROCEDURE	Done
					Date:	Date:
					PROCEDURE	Done
MV-35	Valve	V4A	Nitrator 3B	Water, Nitrobody	3.1.4.1	3.1.4.3
	With Actuator	P-50				
	Solenoid Valve	X-53			3.1.7.1	3.1.7.3
	Limit Switch	EX-AR or EXD-AR			3.7.1.1	3.7.1.3
MV-36	Valve	V1	Nitrator 3B	Hydraulic Oil	3.1.3.2	3.1.3.4
	With Actuator	P-50				
	Solenoid Valve	X-53			3.1.7.1	3.1.7.3
MV-37	Valve	V1	Nitrator 3B	Water	3.1.3.1	3.1.3.4
	With Actuator	P-50				
	Solenoid Valve	X-53			3.1.7.1	3.1.7.3
	Limit Switch	EX-AR or EXD-AR			3.7.1.1	3.7.1.3
MV-38	Valve	V9000	Nitrator 3B	Steam	3.1.5.1	3.1.5.3
	With Actuator	P-50				
	Solenoid Valve	X-53			3.1.7.1	3.1.7.3
	Limit Switch	EX-AR or EXD-AR			3.7.1.1	3.7.1.3
MV-39	Valve	V9000	Nitrator 3B	Steam	3.1.5.1	3.1.5.3
	With Actuator	P-50				
	Solenoid Valve	X-53			3.1.7.1	3.1.7.3
	Limit Switches	EX-AR or EXD-AR			3.7.1.1	3.7.1.3

MV-40  
to  
MV-45

LAYAWAY CHECKLIST: LINE									
TAG NO.	ITEM	MODEL or PART NO.	LOCATION	FLUID	LAYAWAY		REACTIVATE		
					Date:	Done	Date:	Done	
					PROCEDURE		PROCEDURE		
MV-40	Solenoid Valves	X-53, X-55	Nitrator 3B	Air	3.1.7.1		3.1.7.3		
MV-41	Valve With Actuator Solenoid Valve	V9000 P-50 X-53	Separator 3	Water	3.1.5.1		3.1.5.3		
MV-42	Valve With Actuator Solenoid Valve	V9000 P-50 X-53	Separator 3	Steam	3.1.5.1		3.1.5.3		
MV-43	Valve With Actuator Solenoid Valve Limit Switch	F45 (VAAP Line 1) (V5310 others) P-25 X-53 EX-AR or EXD-AR	Separator 3	Steam	3.1.4.1		3.1.4.3		
MV-44	Valve With Actuator Solenoid Valve Limit Switch	V9000 P-50 X-53 EX-AR or EXD-AR	Nitrator 4	Oleum	3.1.5.1		3.1.5.3		
MV-45	Valve With Actuator Solenoid Valve Limit Switch	V4A P-50 X-53 EX-AR or EXD-AR	Nitrator 4	Water, Acid	3.1.4.1		3.1.4.5		

MV-46  
to  
MV-51

LAYAWAY CHECKLIST: LINE _____									
TAG NO.	ITEM	MODEL or PART NO.	LOCATION	FLUID	I AYAWAY		REACTIVATE		
					Date: PROCEDURE	Done	Date: PROCEDURE	Done	
MV-46	Valve With Actuator Solenoid Valve Limit Switch	V1 P-50 X-53 EX-AR or EXD-AR	Nitrator 4	Water	3.1.3.1		3.1.3.4		
					3.1.7.1		3.1.7.3		
					3.7.1.1		3.7.1.3		
					3.1.5.1		3.1.5.3		
MV-47	Valve With Actuator Solenoid Valve Limit Switch	V9000 P-50 X-53 EX-AR or EXD-AR	Nitrator 4	Steam	3.1.5.1		3.1.5.3		
					3.1.7.1		3.1.7.3		
					3.7.1.1		3.7.1.3		
					3.1.5.1		3.1.5.3		
MV-48	Valve With Actuator Solenoid Valve Limit Switch	V9000 P-50 X-53 EX-AR or EXD-AR	Nitrator 4	Steam	3.1.5.1		3.1.5.3		
					3.1.7.1		3.1.7.3		
					3.7.1.1		3.7.1.3		
					3.1.5.1		3.1.5.3		
MV-49	Solenoid Valves	X-53, X-55	Nitrator 4	Air	3.1.7.1		3.1.7.3		
					3.1.5.1		3.1.5.3		
MV-50	Valve With Actuator Solenoid Valve	V9000 P-50 X-53	Separator 4	Water	3.1.5.1		3.1.5.3		
					3.1.7.1		3.1.7.3		
					3.1.5.1		3.1.5.3		
MV-51	Valve With Actuator Solenoid Valve	V9000 P-50 X-53	Separator 4	Steam	3.1.5.1		3.1.5.3		
					3.1.7.1		3.1.7.3		

MV-52  
to  
MV-56

LAYAWAY CHECKLIST: LINE _____		LAYAWAY		REACTIVATE		
TAG NO.	ITEM	MODEL or PART NO.	LOCATION	FLUID	Date:	
					PROCEDURE	Done
MV-52	Valve	F-45 (VAAP Line 1) (V5310 others)	Separator 4	Steam	3.1.1.1	3.1.1.3
	With Actuator Solenoid Valve Limit Switch	P-25 X-53 EX-AR or EXD-AR			3.1.7.1 3.7.1.1	3.1.7.3 3.7.1.3
	Valve	V9000	Nitrator 5	Oleum	3.1.5.1	3.1.5.3
	With Actuator Solenoid Valve Limit Switch	P-50 X-53 EX-AR or EXD-AR			3.1.7.1 3.7.1.1	3.1.7.3 3.7.1.3
MV-54	Valve	V-4A	Nitrator 5	Water, TNT	3.1.4.1	3.1.4.3
	With Actuator Solenoid Valve Limit Switch	P-50 X-53 EX-AR or EXD-AR			3.1.7.1 3.7.1.1	3.1.7.3 3.7.1.3
	Valve	V-1	Nitrator 5	Water	3.1.3.1	3.1.3.4
	With Actuator Solenoid Valve Limit Switch	P-50 X-53 EX-AR or EXD-AR			3.1.7.1 3.7.1.1	3.1.7.3 3.7.1.3
MV-55	Valve	V9000	Nitrator 5	Steam	3.1.5.1	3.1.5.3
	With Actuator Solenoid Valve Limit Switch	P-50 X-53 EX-AR or EXD-AR			3.1.7.1 3.7.1.1	3.1.7.3 3.7.1.3
	Valve	V-1	Nitrator 5	Water	3.1.3.1	3.1.3.4
	With Actuator Solenoid Valve Limit Switch	P-50 X-53 EX-AR or EXD-AR			3.1.7.1 3.7.1.1	3.1.7.3 3.7.1.3
MV-56	Valve	V9000	Nitrator 5	Steam	3.1.5.1	3.1.5.3
	With Actuator Solenoid Valve Limit Switch	P-50 X-53 EX-AR or EXD-AR			3.1.7.1 3.7.1.1	3.1.7.3 3.7.1.3
	Valve	V-1	Nitrator 5	Water	3.1.3.1	3.1.3.4
	With Actuator Solenoid Valve Limit Switch	P-50 X-53 EX-AR or EXD-AR			3.1.7.1 3.7.1.1	3.1.7.3 3.7.1.3

MV-57  
to  
MV-62

LAYAWAY CHECKLIST: LINE									
TAG NO.	ITEM	MODEL or PART NO.	LOCATION	FLUID	LAYAWAY		REACTIVATE		Date:
					PROCEDURE	Done	PROCEDURE	Done	
MV-57	Valve With Actuator Solenoid Valve Limit Switch	V9000 P-50 X-53 EX-AR or EXD-AR	Nitrator 5	Steam	3.1.5.1		3.1.5.3		
MV-58	Solenoid Valves	X-53, X-55	Nitrator 5	Air	3.1.7.1		3.1.7.3		
MV-59	Valve With Actuator Solenoid Valve	V9000 P-50 X-53	Separator 5	Water	3.1.5.1		3.1.5.3		
MV-60	Valve With Actuator Solenoid Valve	V9000 P-50 X-53	Separator 5	Steam	3.1.7.1		3.1.7.3		
MV-61	Valve With Actuator Solenoid Valve Limit Switch	F-45 (VAAP Line 1) (V5310 others) P-25 X-53 EX-AR or EXD-AR	Separator 5	Steam	3.1.5.1		3.1.5.3		
MV-62	Valve With Actuator Solenoid Valve Limit Switch	V9000 P-50 X-53 EX-AR or EXD-AR	Nitrator 6	Oleum	3.1.7.1		3.1.7.3		

MV-63  
to  
MV-68

LAYAWAY CHECKLIST: LINE _____		LAYAWAY				REACTIVATE	
TAG NO.	ITEM	MODEL or PART NO.	LOCATION	FLUID	Date:		Done
					PROCEDURE	PROCEDURE	
MV-63	Valve	V-4A	Nitrator 6	Water, Nitrobody	3.1.4.1	3.1.4.3	
	With Actuator Solenoid Valve Limit Switch	P-50 X-53 EX-AR or EXD-AR			3.1.7.1 3.7.1.1	3.1.7.3 3.7.1.3	
	Valve	V-1	Nitrator 6	Water	3.1.3.1	3.1.3.4	
MV-64	With Actuator Solenoid Valve Limit Switch	P-50 X-53 EX-AR or EXD-AR			3.1.7.1 3.7.1.1	3.1.7.3 3.7.1.3	
	Valve	V9000	Nitrator 6	Steam	3.1.5.1	3.1.5.3	
	With Actuator Solenoid Valve Limit Switch	P-50 X-53 EX-AR or EXD-AR			3.1.7.1 3.7.1.1	3.1.7.3 3.7.1.3	
MV-65	Valve	V9000	Nitrator 6	Steam	3.1.5.1	3.1.5.3	
	With Actuator Solenoid Valve Limit Switch	P-50 X-53 EX-AR or EXD-AR			3.1.7.1 3.7.1.1	3.1.7.3 3.7.1.3	
	Valve	V9000	Nitrator 6	Steam	3.1.5.1	3.1.5.3	
MV-66	With Actuator Solenoid Valve Limit Switch	P-50 X-53 EX-AR or EXD-AR			3.1.7.1 3.7.1.1	3.1.7.3 3.7.1.3	
	Solenoid Valves	X-53, X-55	Nitrator 6	Air	3.1.7.1	3.1.7.3	
	Valve	V9000	Separator 6	Water	3.1.5.1	3.1.5.3	
MV-67	With Actuator Solenoid Valve	P-50 X-53			3.1.7.1	3.1.7.3	
	Limit Switch	EX-AR or EXD-AR			3.7.1.1	3.7.1.3	
MV-68	Valve	V9000	Separator 6	Water	3.1.5.1	3.1.5.3	
	With Actuator Solenoid Valve	P-50 X-53			3.1.7.1	3.1.7.3	
	Limit Switch	EX-AR or EXD-AR			3.7.1.1	3.7.1.3	

MV-69  
to  
MV-74

LAYAWAY CHECKLIST: LINE									
TAG NO.	ITEM	MODEL or PART NO.	LOCATION	FLUID	LAYAWAY		REACTIVATE		
					PROCEDURE	Done	Date:	PROCEDURE	Done
MV-69	Valve With Actuator Solenoid Valve	V9000	Separator 6	Steam	3.1.5.1		3.1.5.3		
		P-50							
		X-53							
MV-70	Valve With Actuator Solenoid Valve Limit Switch	F-45 (VAAP Line 1) (V5310 others)	Separator 6	Steam	3.1.7.1		3.1.7.3		
		P-25			3.1.1.1		3.1.1.3		
		X-53			3.1.7.1		3.1.7.3		
		EX-AR or EXD-AR			3.7.1.1		3.7.1.3		
MV-71	Valve With Actuator Solenoid Valve	V-1	Nitrator 4	Hydraulic Oil	3.1.3.2		3.1.3.4		
		P-110							
		X-53			3.1.7.1		3.1.7.3		
MV-72	Valve With Actuator Solenoid Valve	V-1	Nitrator 5	Hydraulic Oil	3.1.3.2		3.1.3.4		
		P-110							
		X-53			3.1.7.1		3.1.7.3		
MV-73	Valve With Actuator Solenoid Valve	V-1	Nitrator 6	Hydraulic Oil	3.1.3.2		3.1.3.4		
		P-110							
		X-53			3.1.7.1		3.1.7.3		
MV-74	Valve With Actuator Solenoid Valve	V9000	Acid Washer	Steam	3.1.5.1		3.1.5.3		
		P-50							
		X-53			3.1.7.1		3.1.7.3		

MV-75  
to  
MV-80

LAYAWAY CHECKLIST: LINE									
TAG NO.	ITEM	MODEL or PART NO.	LOCATION	FLUID	LAYAWAY		REACTIVATE		
					Date: PROCEDURE	Done	Date: PROCEDURE	Done	
MV-75	Valve With Actuator Solenoid Valve	V9000 P-50 X-53	Nitrator 6	Steam	3.1.5.1		3.1.5.3		
MV-76	Valve With Actuator Solenoid Valve	V-1 P-50 X-53	Sellite Washer 1	Hydraulic Oil	3.1.7.1		3.1.7.3		
MV-77	Valve With Actuator Solenoid Valve	V-1 P-50 X-53	Sellite Washer 2	Hydraulic Oil	3.1.7.1		3.1.7.3		
MV-78	Valve With Actuator Solenoid Valve Limit Switch	G-2 P-50 X-53 EX-AR or EXD-AR	Acid Washer	TNT	3.1.2.1		3.1.2.3		
MV-79	Valve With Actuator Solenoid Valve	V9000 P-50 X-53	TNT Pump Tank	Steam	3.1.5.1		3.1.5.3		
MV-80	Valve With Actuator Solenoid Valve	V9000 P-50 X-53	Acid Washer	Steam	3.1.5.1		3.1.5.3		
					3.1.7.1		3.1.7.3		

MV-81  
to  
MV-86

LAYAWAY CHECKLIST: LINE									
TAG NO.	ITEM	MODEL or PART NO.	LOCATION	FLUID	LAYAWAY		REACTIVATE		
					Date: PROCEDURE	Done	Date: PROCEDURE	Done	
MV-81	Valve	V9000	Sellite Washer 1	Steam	3.1.5.1		3.1.5.3		
	With Actuator	P-50							
	Solenoid Valve	X-53							
MV-82	Valve	V9000	Sellite Separator 1	Steam	3.1.7.1		3.1.7.3		
	With Actuator	P-50							
	Solenoid Valve	X-53							
MV-83	Valve	V9000	Sellite Washer 2	Steam	3.1.5.1		3.1.5.3		
	With Actuator	P-50							
	Solenoid Valve	X-53							
MV-84	Valve	V9000	Sellite Separator 2	Steam	3.1.7.1		3.1.7.3		
	With Actuator	P-50							
	Solenoid Valve	X-53							
MV-85	Valve	V9000	Post Sellite Washer	Steam	3.1.5.1		3.1.5.3		
	With Actuator	P-50							
	Solenoid Valve	X-53							
MV-86	Valve	V9000	Post Sellite Washer	Steam	3.1.7.1		3.1.7.3		
	With Actuator	P-50							
	Solenoid Valve	X-53							

MV-87  
to  
MV-93

LAYAWAY CHECKLIST: LINE _____		LAYAWAY		REACTIVATE		
TAG NO.	ITEM	MODEL or PART NO.	LOCATION	FLUID	Date:	
					PROCEDURE	Done
MV-87	Valve	V9000	Yellow Water Pump Tank	Steam	3.1.5.1	3.1.5.3
	With Actuator Solenoid Valve	P-50 X-53			3.1.7.1	3.1.7.3
	Valve	V9000	Recycle Water Tank	Steam	3.1.5.1	3.1.5.3
MV-88	With Actuator Solenoid Valve	P-50 X-53			3.1.7.1	3.1.7.3
	Valve	V9000	Recycle Water Tank	Steam	3.1.5.1	3.1.5.3
	With Actuator Solenoid Valve	P-50 X-53			3.1.7.1	3.1.7.3
MV-90	Valve	V-1	TNT Eductor Tank	Hydraulic	3.1.3.2	3.1.3.4
	With Actuator Solenoid Valve	P-50 X-53			3.1.7.1	3.1.7.3
	Valve	G-2	TNT Pump Tank	TNT, Water	3.1.2.1	3.1.2.3
MV-91	With Actuator Solenoid Valve	P-50 X-53			3.1.7.1	3.1.7.3
	Valve	V-4A	Yellow Water Pump Tank	Process	3.1.4.1	3.1.4.3
	With Actuator Solenoid Valve	P-50 X-53			3.1.7.1	3.1.7.3
MV-93	Valve	V-4A	Yellow Water Pump Tank	Process	3.1.4.1	3.1.4.3
	With Actuator Solenoid Valve	P-50 X-53			3.1.7.1	3.1.7.3
	Valve	V-4A	Yellow Water Pump Tank	Process	3.1.4.1	3.1.4.3

PHT-1  
to  
PHT-4

LAYAWAY CHECKLIST: LINE _____		REACTIVATE						
TAG NO.	ITEM	MODEL or PART NO.	LOCATION	FLUID	LAYAWAY		REACTIVATE	
					PROCEDURE	Done	Date:	PROCEDURE
PHT-1	pH Electrode	Q0104AW Q0104AP	Acid Washer	Acid, Nitrobody	3.8.3.1		3.8.3.3	
	pH-to-Current Converter	699	Hydraulic Pump House		3.5.4.1		3.5.4.3	
PHT-2	pH Electrode	Q0104AW Q0104AP	Sellite Separator 1	Nitrobody	3.8.3.1		3.8.3.3	
	pH-to-Current Converter	699	Hydraulic Pump House		3.5.4.1		3.5.4.3	
PHT-3	pH Electrode	Q0104AW Q0104AP	Sellite Separator 2	Sellited Nitrobody	3.8.3.1		3.8.3.3	
	pH-to-Current Converter	699	Hydraulic Pump House		3.5.4.1		3.5.4.3	
PHT-4	pH Electrode	Q0104AW Q0104AP	Post Sellite Washer	TNT, Water	3.8.3.1		3.8.3.3	
	pH-to-Current Converter	699	Hydraulic Pump House		3.5.4.1		3.5.4.3	

PS-1  
to  
PS-13

LAYAWAY CHECKLIST: LINE									
TAG NO.	ITEM	MODEL or PART NO.	LOCATION	FLUID	LAYAWAY		REACTIVATE		
					Date:	PROCEDURE	Date:	PROCEDURE	
						Done		Done	
PS-1	Mercoird Pressure Control	DAH-31	Nitrator 4	Water	3.3.4.1		3.3.4.3		
PS-2	Mercoird Pressure Control	DAH-31	Nitrator 4	Water	3.3.4.1		3.3.4.3		
PS-3	Mercoird Pressure Control	DAH-21	Fume Exhaust 2	Nitrobody, Acid Fumes	3.3.4.1		3.3.4.3		
PS-4	Mercoird Pressure Control	DAH-21	Fume Exhaust 1	Nitrobody, Acid Fumes	3.3.4.1		3.3.4.3		
PS-5	Mercoird Pressure Control	DAH-21	Penthouse	Nitrobody, Acid Fumes	3.3.4.1		3.3.4.3		
PS-6	Mercoird Pressure Control	DAH-21	Fume Exhaust 2 (Remilt Room)	Nitrobody, Acid Fumes	3.3.4.1		3.3.4.3		
PS-7	Mercoird Pressure Control	DAH-31	Nitrator 6	Steam	3.3.4.1		3.3.4.3		
PS-8	Mercoird Pressure Control	DAH-31	Nitrator 6	Steam	3.3.4.1		3.3.4.3		
PS-9	Mercoird Pressure Control	DAH-31	Metering Pump House	Air	3.3.4.1		3.3.4.3		
PS-10	Mercoird Pressure Control	DAH-31	Metering Pump House	Air	3.3.4.1		3.3.4.3		
PS-11	Mercoird Pressure Control	DAH-21	Hydraulic Pump House	Hydraulic Oil	3.3.4.1		3.3.4.3		
PS-12	Mercoird Pressure Control	DAH-31	Sellite Building	Air	3.3.4.1		3.3.4.3		
PS-13	Mercoird Pressure Control	DAH-31	Sellite Building	Air	3.3.4.1		3.3.4.3		

PS-14  
to  
PS-19

LAYAWAY CHECKLIST: LINE _____									
TAG NO.	ITEM	MODEL or PART NO.	LOCATION	FLUID	LAYAWAY		REACTIVATE		
					Date:	PROCEDURE	Date:	PROCEDURE	
PS-14	Mercoild Pressure Control	DAH-31	Sellite Building	Air	3.3.4.1		3.3.4.3	Done	
PS-15	Mercoild Pressure Control	DAH-31	Post Sellite Washer	Water	3.3.4.1		3.3.4.3		
PS-16	Mercoild Pressure Control	DAW-33	Casual Water Tank	Air	3.3.4.1		3.3.4.3		
PS-18	Mercoild Pressure Control	DAW-33	Acid Water Settling Tank	Air	3.3.4.1		3.3.4.3		
PS-19	Mercoild Pressure Control	DAW-33	Yellow Water Settling Tank	Air	3.3.4.1		3.3.4.3		

SCV-1  
to  
SCV-6

LAYAWAY CHECKLIST: LINE _____													
TAG NO.	ITEM	MODEL or PART NO.	LOCATION	FLUID	LAYAWAY		REACTIVATE		Done				
					PROCEDURE	Date:	PROCEDURE	Date:					
SCV-1	Valve	V-1	Nitrator 1A	Hydraulic Oil	3.1.3.2	3.1.3.4	3.1.3.4	3.1.3.4					
	With Actuator	P-50	Nitrator 1B							3.7.2.1	3.1.3.4	3.7.2.3	3.1.3.4
	Current to Air Positioner	69PA-1											
SCV-2	Valve	V-1	Nitrator 1B	Hydraulic Oil	3.1.3.2	3.1.3.4	3.1.3.4	3.1.3.4					
	With Actuator	P-50	Nitrator 2							3.7.2.1	3.1.3.4	3.7.2.3	
	Current to Air Positioner	69PA-1											
SCV-3	Valve	V-1	Nitrator 2	Hydraulic Oil	3.1.3.2	3.1.3.4	3.1.3.4	3.1.3.4					
	With Actuator	P-110	Nitrator 3A							3.7.2.1	3.1.3.4	3.7.2.3	
	Current to Air Positioner	69PA-1											
SCV-4	Valve	V-1	Nitrator 3A	Hydraulic Oil	3.1.3.2	3.1.3.4	3.1.3.4	3.1.3.4					
	With Actuator	P-110	Nitrator 3B							3.7.2.1	3.1.3.4	3.7.2.3	
	Current to Air Positioner	69PA-1											
SCV-5	Valve	V-1	Nitrator 3B	Hydraulic Oil	3.1.3.2	3.1.3.4	3.1.3.4	3.1.3.4					
	With Actuator	P-110	Nitrator 4							3.7.2.1	3.1.3.4	3.7.2.3	
	Current to Air Positioner	69PA-1											
SCV-6	Valve	V-1	Nitrator 4	Hydraulic Oil	3.1.3.2	3.1.3.4	3.1.3.4	3.1.3.4					
	With Actuator	P-50	Nitrator 4							3.7.2.1	3.7.2.3		
	Current to Air Positioner	69PA-1											

SCV-7  
to  
SCV-10

LAYAWAY CHECKLIST: LINE _____									
TAG NO.	ITEM	MODEL or PART NO.	LOCATION	FLUID	LAYAWAY		REACTIVATE		
					Date: PROCEDURE	Done	Date: PROCEDURE	Done	
SCV-7	Valve	V-1	Nitrator 5	Hydraulic Oil	3.1.3.2		3.1.3.4		
	With Actuator	P-50							
	Current to Air Positioner	69PA-1							
SCV-8	Valve	V-1	Nitrator 6	Hydraulic Oil	3.7.2.1		3.7.2.3		
	With Actuator	P-50			3.1.3.2		3.1.3.4		
	Current to Air Positioner	69PA-1							
SCV-9	Valve	V-1	Sellite Washer 1	Hydraulic	3.7.2.1		3.7.2.3		
	With Actuator	P-50			3.1.3.2		3.1.3.4		
	Current to Air Positioner	69PA-1							
SCV-10	Valve	V-1	Sellite Washer 2	Hydraulic Oil	3.7.2.1		3.7.2.3		
	With Actuator	P-50			3.1.3.2		3.1.3.4		
	Current to Air Positioner	69PA-1							

ST-1  
to  
ST-6

LAYAWAY CHECKLIST: LINE									
TAG NO.	ITEM	MODEL or PART NO.	LOCATION	FLUID	LAYAWAY		REACTIVATE		
					Date:	PROCEDURE	Date:	PROCEDURE	
					Done	Done	Done	Done	
ST-1	Electro Magnetic Pickup	3075	Nitrator 1A	--			3.6.3.1	3.6.3.3	
	Pulse/Current Converter	99V	Hydraulic Pump House				3.5.5.1	3.5.5.3	
	Amplifier	PA 106A					3.8.4.1	3.8.4.3	
ST-2	Electro Magnetic Pickup	3075	Nitrator 1B	--			3.6.3.1	3.6.3.3	
	Pulse/Current Converter	99V	Hydraulic Pump House				3.5.5.1	3.5.5.3	
	Amplifier	PA 106A					3.8.4.1	3.8.4.3	
ST-3	Electro Magnetic Pickup	3075	Nitrator 2	--			3.6.3.1	3.6.3.3	
	Pulse/Current Converter	99V	Hydraulic Pump House				3.5.5.1	3.5.5.3	
	Amplifier	PA 106A					3.8.4.1	3.8.4.3	
ST-4	Electro Magnetic Pickup	3075	Nitrator 3A	--			3.6.3.1	3.6.3.3	
	Pulse/Current Converter	99V	Hydraulic Pump House				3.5.5.1	3.5.5.3	
	Amplifier	PA 106A					3.8.4.1	3.8.4.3	
ST-5	Electro Magnetic Pickup	3075	Nitrator 3B	--			3.6.3.1	3.6.3.3	
	Pulse/Current Converter	99V	Hydraulic Pump House				3.5.5.1	3.5.5.3	
	Amplifier	PA 106A					3.8.4.1	3.8.4.3	
ST-6	Electro Magnetic Pickup	3075	Nitrator 4	--			3.6.3.1	3.6.3.3	
	Pulse/Current Converter	99V	Hydraulic Pump House				3.5.5.1	3.5.5.3	
	Amplifier	PA 106A					3.8.4.1	3.8.4.3	

ST-7  
to  
ST-10

LAYAWAY CHECKLIST: LINE									
TAG NO.	ITEM	MODEL or PART NO.	LOCATION	FLUID	LAYAWAY		REACTIVATE		
					Date:	PROCEDURE	Date:	PROCEDURE	
ST-7	Electro Magnetic Pickup Pulse/Current Converter Amplifier	3075	Nitrator 5	--					
		99V	Hydraulic Pump House			3.6.3.1	3.6.3.3		
		PA 106A				3.5.5.1	3.5.5.3		
ST-8	Electro Magnetic Pickup Pulse/Current Converter Amplifier	3075	Nitrator 6	--					
		99V	Hydraulic Pump House			3.6.3.1	3.6.3.3		
		PA 106A				3.5.5.1	3.5.5.3		
ST-9	Electro Magnetic Pickup Pulse/Current Converter Amplifier	3075	Sellite Washer 1	--					
		99V	Hydraulic Pump House			3.6.3.1	3.6.3.3		
		PA 106A				3.5.5.1	3.5.5.3		
ST-10	Electro Magnetic Pickup Pulse/Current Converter Amplifier	3075	Sellite Washer 2	--					
		99V	Hydraulic Pump House			3.6.3.1	3.6.3.3		
		PA 106A				3.5.5.1	3.5.5.3		
						3.8.4.1	3.8.4.3		

TCV-1  
to  
TCV-6

LAYAWAY CHECKLIST: LINE _____		LAYAWAY		REACTIVATE		
TAG NO.	ITEM	MODEL or PART NO.	LOCATION	FLUID	Date:	
					PROCEDURE	Done
TCV-1	Valve With Actuator Solenoid Valve Current-to-Air Positioner	V-1 P-50 X-53 69PA-1	Nitrator 1A	Water	3.1.3.1	3.1.3.4
					3.1.7.1	3.1.7.3
					3.7.2.1	3.7.2.3
					3.1.3.1	3.1.3.4
TCV-2	Valve With Actuator Solenoid Valve Current-to-Air Positioner	V-1 P-50 X-53 69PA-1	Nitrator 1B	Water	3.1.7.1	3.1.7.3
					3.7.2.1	3.7.2.3
					3.1.3.1	3.1.3.4
					3.1.7.1	3.1.7.3
TCV-3	Valve With Actuator Solenoid Valve Current-to-Air Positioner	V-1 P-50 X-53 69PA-1	Nitrator 2	Water	3.1.3.1	3.1.3.4
					3.1.7.1	3.1.7.3
					3.7.2.1	3.7.2.3
					3.1.3.1	3.1.3.4
TCV-4	Valve With Actuator Solenoid Valve Current-to-Air Positioner	V-1 P-50 X-53 69PA-1	Nitrator 3A	Water	3.1.3.1	3.1.3.4
					3.1.7.1	3.1.7.3
					3.7.2.1	3.7.2.3
					3.1.3.1	3.1.3.4
TCV-5	Valve With Actuator Solenoid Valve Current-to-Air Positioner	V-1 P-50 X-53 69PA-1	Nitrator 3B	Water	3.1.7.1	3.1.7.3
					3.7.2.1	3.7.2.3
					3.1.3.1	3.1.3.4
					3.1.7.1	3.1.7.3
TCV-6	Valve With Actuator Solenoid Valve Current-to-Air Positioner	V-1 P-50 X-53 69PA-1	Nitrator 4	Water	3.1.7.1	3.1.7.3
					3.7.2.1	3.7.2.3
					3.1.3.1	3.1.3.4
					3.1.7.1	3.1.7.3

LAYAWAY CHECKLIST: LINE		TCV-7		TCV-16				
TAG NO.	ITEM	MODEL or PART NO.	LOCATION	FLUID	LAYAWAY		REACTIVATE	
					Date: PROCEDURE	Done	Date: PROCEDURE	Done
TCV-7	Valve	V-1	Nitrator 5	Water	3.1.3.1		3.1.3.4	
	With Actuator	P-25			3.1.7.1		3.1.7.3	
	Solenoid Valve	X-53			3.7.2.1		3.7.2.3	
	Current-to-Air Positioner	69PA-1			3.1.3.1		3.1.3.4	
TCV-8	Valve	V-1	Nitrator 6	Water	3.1.3.1		3.1.3.4	
	With Actuator	P-25			3.1.7.1		3.1.7.3	
	Solenoid Valve	X-53			3.7.2.1		3.7.2.3	
	Current-to-Air Positioner	69PA-1			3.1.3.1		3.1.3.4	
TCV-9	Valve	V-1	Sellite Washer 1	Water	3.1.3.1		3.1.3.4	
	With Actuator	P-50			3.1.7.1		3.1.7.3	
	Solenoid Valve	X-53			3.7.2.1		3.7.2.3	
	Current-to-Air Positioner	69PA-1			3.1.3.1		3.1.3.4	
TCV-10	Valve	V-1	Sellite Washer 2	Water	3.1.3.1		3.1.3.4	
	With Actuator	P-50			3.1.7.1		3.1.7.3	
	Solenoid Valve	X-53			3.7.2.1		3.7.2.3	
	Current-to-Air Positioner	69PA-1			3.1.3.1		3.1.3.4	
TCV-16	Valve	V-1	Acid Washer	Water	3.1.3.1		3.1.3.4	
	With Actuator	P-25			3.1.7.1		3.1.7.3	
	Solenoid Valve	X-53			3.7.2.1		3.7.2.3	
	Current-to-Air Positioner	69PA-1			3.1.3.1		3.1.3.4	

LAYAWAY CHECKLIST: LINE _____									
TAG NO.	ITEM	MODEL or PART NO.	LOCATION	FLUID	LAYAWAY		REACTIVATE		
					Date:	Done	Date:	Done	
					PROCEDURE	Done	PROCEDURE	Done	
TCV-51	Valve With Actuator Solenoid Valve Current-to-Air Positioner	V-1 P-25 X-53 69PA-1	Red Water Pump Tank	Steam	3.1.3.1		3.1.3.4		
					3.1.7.1 3.7.2.1		3.1.7.3 3.7.2.3		

TS-1  
to  
TS-22

LAYAWAY CHECKLIST: LINE		ITEM	MODEL or PART NO.	LOCATION	FLUID	LAYAWAY		REACTIVATE		
TAG NO.	DATE					PROCEDURE	DATE	PROCEDURE	Done	Done
TS-1		Mercoild Temperature Control	DAH-35	Separator 1	--		3.4.2.1	3.4.2.3		
TS-2		Mercoild Temperature Control	DAH-35	Nitrator 1A	--		3.4.2.1	3.4.2.3		
TS-3		Mercoild Temperature Control	DAH-35	Nitrator 1A	--		3.4.2.1	3.4.2.3		
TS-4		Mercoild Temperature Control	DAH-35	Nitrator 1B	--		3.4.2.1	3.4.2.3		
TS-5		Mercoild Temperature Control	DAH-35	Nitrator 1B	--		3.4.2.1	3.4.2.3		
TS-6		Mercoild Temperature Control	DAH-35	Nitrator 2	--		3.4.2.1	3.4.2.3		
TS-7		Mercoild Temperature Control	DAH-35	Nitrator 2	--		3.4.2.1	3.4.2.3		
TS-8		Mercoild Temperature Control	DAH-35	Nitrator 3A	--		3.4.2.1	3.4.2.3		
TS-9		Mercoild Temperature Control	DAH-35	Nitrator 3A	--		3.4.2.1	3.4.2.3		
TS-10		Mercoild Temperature Control	DAH-35	Nitrator 3B	--		3.4.2.1	3.4.2.3		
TS-11		Mercoild Temperature Control	DAH-35	Nitrator 3B	--		3.4.2.1	3.4.2.3		
TS-12		Mercoild Temperature Control	DAH-35	Nitrator 4	--		3.4.2.1	3.4.2.3		
TS-13		Mercoild Temperature Control	DAH-35	Nitrator 4	--		3.4.2.1	3.4.2.3		
TS-14		Mercoild Temperature Control	DAH-35	Nitrator 5	--		3.4.2.1	3.4.2.3		
TS-15		Mercoild Temperature Control	DAH-35	Nitrator 5	--		3.4.2.1	3.4.2.3		
TS-16		Mercoild Temperature Control	DAH-35	Nitrator 6	--		3.4.2.1	3.4.2.3		
TS-17		Mercoild Temperature Control	DAH-35	Nitrator 6	--		3.4.2.1	3.4.2.3		
TS-18		Mercoild Temperature Control	DAH-35	Separator 1	--		3.4.2.1	3.4.2.3		
TS-19		Mercoild Temperature Control	DAH-35	Separator 2	--		3.4.2.1	3.4.2.3		
TS-20		Mercoild Temperature Control	DAH-35	Separator 3	--		3.4.2.1	3.4.2.3		
TS-21		Mercoild Temperature Control	DAH-35	Separator 4	--		3.4.2.1	3.4.2.3		
TS-22		Mercoild Temperature Control	DAH-35	Separator 5	--		3.4.2.1	3.4.2.3		

TS-23  
to  
TS-25

LAYAWAY CHECKLIST: LINE _____		ITEM		MODEL or PART NO.	LOCATION	FLUID	LAYAWAY		REACTIVATE			
TAG NO.							Date:	PROCEDURE	Done	Date:	PROCEDURE	Done
TS-23		Mercoïd Temperature Control		DAH-35	Separator 6	--		3. 4. 2. 1		3. 4. 2. 3		
TS-24		Mercoïd Temperature Control		DAH-35	Hydraulic Pump House	--		3. 4. 2. 1		3. 4. 2. 3		
TS-25		Mercoïd Temperature Control		DAH-35	Utility Room	--		3. 4. 2. 1		3. 4. 2. 3		

TT-1  
to  
TT-9

LAYAWAY CHECKLIST: LINE		TT-1 to TT-9									
TAG NO.	ITEM	MODEL or PART NO.	LOCATION	FLUID	LAYAWAY		REACTIVATE				
					Date: PROCEDURE	Done	Date: PROCEDURE	Done			
TT-1	Dynatherm Resistance Bulb Resistance to Current Converter	DB-12P 694A	Nitrator 1A Hydraulic Pump House	--	3.4.1.1 3.5.2.1		3.4.1.3 3.5.2.3				
TT-2	Dynatherm Resistance Bulb Resistance to Current Converter	DB-12P 694A	Nitrator 1B Hydraulic Pump House	--	3.4.1.1 3.5.2.1		3.4.1.3 3.5.2.3				
TT-3	Dynatherm Resistance Bulb Resistance to Current Converter	DB-12P 694A	Separator 1 Hydraulic Pump House	--	3.4.1.1 3.5.2.1		3.4.1.3 3.5.2.3				
TT-4	Dynatherm Resistance Bulb Resistance to Current Converter	DB-12P 694A	Nitrator 2 Hydraulic Pump House	--	3.4.1.1 3.5.2.1		3.4.1.3 3.5.2.3				
TT-5	Dynatherm Resistance Bulb Resistance to Current Converter	DB-12P 694A	Separator 2 Hydraulic Pump House	--	3.4.1.1 3.5.2.1		3.4.1.3 3.5.2.3				
TT-6	Dynatherm Resistance Bulb Resistance to Current Converter	DB-12P 694A	Nitrator 3A Hydraulic Pump House	--	3.4.1.1 3.5.2.1		3.4.1.3 3.5.2.3				
TT-7	Dynatherm Resistance Bulb Resistance to Current Converter	DB-12P 694A	Nitrator 3B Hydraulic Pump House	--	3.4.1.1 3.5.2.1		3.4.1.3 3.5.2.3				
TT-8	Dynatherm Resistance Bulb Resistance to Current Converter	DB-12P 694A	Separator 3 Hydraulic Pump House	--	3.4.1.1 3.5.2.1		3.4.1.3 3.5.2.3				
TT-9	Dynatherm Resistance Bulb Resistance to Current Converter	DB-12P 694A	Nitrator 4 Hydraulic Pump House	--	3.4.1.1 3.5.2.1		3.4.1.3 3.5.2.3				

TT-10  
to  
TT-17

LAYAWAY CHECKLIST: LINE		LAYAWAY									
TAG NO.	ITEM	MODEL or PART NO.	LOCATION	FLUID	LAYAWAY		REACTIVATE				
					Date: PROCEDURE	Done	Date: PROCEDURE	Done			
TT-10	Dynatherm Resistance Bulb Resistance to Current Converter	DB-12P 694A	Separator 4 Hydraulic Pump House	--	3.4.1.1 3.5.2.1		3.4.1.3 3.5.2.3				
TT-11	Dynatherm Resistance Bulb Resistance to Current Converter	DB-12P 694A	Nitrator 5 Hydraulic Pump House	--	3.4.1.1 3.5.2.1		3.4.1.3 3.5.2.3				
TT-12	Dynatherm Resistance Bulb Resistance to Current Converter	DB-12P 694A	Separator 5 Hydraulic Pump House	--	3.4.1.1 3.5.2.1		3.4.1.3 3.5.2.3				
TT-13	Dynatherm Resistance Bulb Resistance to Current Converter	DB-12P 694A	Nitrator 6 Hydraulic Pump House	--	3.4.1.1 3.5.2.1		3.4.1.3 3.5.2.3				
TT-14	Dynatherm Resistance Bulb Resistance to Current Converter	DB-12P 694A	Separator 6 Hydraulic Pump House	--	3.4.1.1 3.5.2.1		3.4.1.3 3.5.2.3				
TT-15	Dynatherm Resistance Bulb Resistance to Current Converter	DB-12P 694A	Yellow Water Pump Tank Hydraulic Pump House	--	3.4.1.1 3.5.2.1		3.4.1.3 3.5.2.3				
TT-16	Dynatherm Resistance Bulb Resistance to Current Converter	DB-12P 694A	Acid Washer Hydraulic Pump House	--	3.4.1.1 3.5.2.1		3.4.1.3 3.5.2.3				
TT-17	Dynatherm Resistance Bulb Resistance to Current Converter	DB-12P 694A	Acid Washer Hydraulic Pump House	--	3.4.1.1 3.5.2.1		3.4.1.3 3.5.2.3				

TT-18  
to  
TT-41

LINE NO.	ITEM	MODEL OF PART NO.	LOCATION	FLUID	LAYAWAY		REACTIVATE	
					Date:	Done	Date:	Done
					PROCEDURE	PROCEDURE	PROCEDURE	PROCEDURE
TT-18	Dynatherm Resistance Bulb Resistance to Current Converter	DB-12P 694A	Sellite Washer 1 Hydraulic Pump House	--	3.4.1.1 3.5.2.1	3.4.1.3 3.5.2.3		
TT-19	Dynatherm Resistance Bulb Resistance to Current Converter	DB-12P 694A	Sellite Separator 1 Hydraulic Pump House	--	3.4.1.1 3.5.2.1	3.4.1.3 3.5.2.3		
TT-20	Dynatherm Resistance Bulb Resistance to Current Converter	DB-12P 694A	Sellite Washer 2 Hydraulic Pump House	--	3.4.1.1 3.5.2.1	3.4.1.3 3.5.2.3		
TT-21	Dynatherm Resistance Bulb Resistance to Current Converter	DB-12P 694A	Sellite Separator 2 Hydraulic Pump House	--	3.4.1.1 3.5.2.1	3.4.1.3 3.5.2.3		
TT-22	Dynatherm Resistance Bulb Resistance to Current Converter	DB-12P 694A	Post Sellite Washer Hydraulic Pump House	--	3.4.1.1 3.5.2.1	3.4.1.3 3.5.2.3		
TT-23	Dynatherm Resistance Bulb Resistance to Current Converter	DB-12P 694A	TNT Pump Tank Hydraulic Pump House	--	3.4.1.1 3.5.2.1	3.4.1.3 3.5.2.3		
TT-41	Dynatherm Resistance Bulb Resistance to Current Converter	DB-12P 694A	Nitrator 1A Hydraulic Pump House	--	3.4.1.1 3.5.2.1	3.4.1.3 3.5.2.3		

TT-42  
to  
TT-49

LAYAWAY CHECKLIST: LINE		REACTIVATE										
TAG NO.	ITEM	MODEL or PART NO.	LOCATION	FLUID	LAYAWAY		REACTIVATE		PROCEDURE		Date:	
					PROCEDURE	Done	PROCEDURE	Done	PROCEDURE	Done	PROCEDURE	Done
TT-42	Dynatherm Resistance Bulb Resistance to Current Converter	DB-12P 694A	Nitrator 1B Hydraulic Pump House	--		3.4.1.1 3.5.2.1		3.4.1.3 3.5.2.3				
TT-43	Dynatherm Resistance Bulb Resistance to Current Converter	DB-12P 694A	Nitrator 2 Hydraulic Pump House	--		3.4.1.1 3.5.2.1		3.4.1.3 3.5.2.3				
TT-44	Dynatherm Resistance Bulb Resistance to Current Converter	DB-12P 694A	Nitrator 3A Hydraulic Pump House	--		3.4.1.1 3.5.2.1		3.4.1.3 3.5.2.3				
TT-45	Dynatherm Resistance Bulb Resistance to Current Converter	DB-12P 694A	Nitrator 3B Hydraulic Pump House	--		3.4.1.1 3.5.2.1		3.4.1.3 3.5.2.3				
TT-46	Dynatherm Resistance Bulb Resistance to Current Converter	DB-12P 694A	Nitrator 4 Hydraulic Pump House	--		3.4.1.1 3.5.2.1		3.4.1.3 3.5.2.3				
TT-47	Dynatherm Resistance Bulb Resistance to Current Converter	DB-12P 694A	Nitrator 5 Hydraulic Pump House	--		3.4.1.1 3.5.2.1		3.4.1.3 3.5.2.3				
TT-48	Dynatherm Resistance Bulb Resistance to Current Converter	DB-12P 694A	Nitrator 6 Hydraulic Pump House	--		3.4.1.1 3.5.2.1		3.4.1.3 3.5.2.3				
TT-49	Dynatherm Resistance Bulb Resistance to Current Converter	DB-12P 694A	Nitrator 4 Hydraulic Pump House	--		3.4.1.1 3.5.2.1		3.4.1.3 3.5.2.3				

TT-50  
to  
TT-52

LAYAWAY CHECKLIST: LINE _____		REACTIVATE					
TAG NO.	ITEM	MODEL or PART NO.	LOCATION	FLUID	LAYAWAY		
					PROCEDURE	Done	
					Date:	PROCEDURE	Done
TT-50	Dynatherm Resistance Bulb	DB-12P	Steam Injection Water Heater	--		3.4.1.1	
	Resistance to Current Converter	694A	Hydraulic Pump House			3.5.2.1	3.5.2.3
TT-51	Dynatherm Resistance Bulb	DB-12P	Recycle Water Tank	--		3.4.1.1	
	Resistance to Current Converter	694A	Hydraulic Pump House			3.5.2.1	3.5.2.3
TT-52	Dynatherm Resistance Bulb	DB-13N	Recycle Water Tank	--		3.4.1.1	
	Resistance to Current Converter	694A	Hydraulic Pump House			3.5.2.1	3.5.2.3