

AD-A046 163

AERONAUTICAL SYSTEMS DIV WRIGHT-PATTERSON AFB OHIO
MILITARY TRANSPORT (C-141) FLY-BY-WIRE PROGRAM.(U)
MAR 77 J A LACKEY
ASD-TR-77-8

F/G 1/3

UNCLASSIFIED

NL

| OF |
AD
A046 163



END
DATE
FILMED
12-77
DDC

AD A 046163

ASD TR 77-8

12

J



MILITARY TRANSPORT (C-141) FLY-BY-WIRE PROGRAM

MARCH 1977

Final Report

September 1972 - May 1974

Approved for public release; distribution unlimited.

AD NO. _____
DDC FILE COPY:

4950TH TEST WING
AIR FORCE SYSTEMS COMMAND
WRIGHT-PATTERSON AIR FORCE BASE, OHIO

DDC
RECEIVED
NOV 3 1977
B

NOTICE

When Government drawings, specifications, or other data are used for any purpose other than in connection with a definitely related Government procurement operation, the United States Government thereby incurs no responsibility nor any obligation whatsoever; and the fact that the government may have formulated, furnished, or in any way supplied the said drawings, specifications, or other data, is not to be regarded by implication or otherwise as in any manner licensing the holder or any other person or corporation, or conveying any rights or permission to manufacture, use, or sell any patented invention that may in any way be related thereto.

DISTRIBUTION: 1 cy AFAL/TSR, WPAFB, OH 45433
1 cy 2750ABW/SSL, WPAFB, OH 45433
1 cy Air University Library, Maxwell AFB, AL 36112
12 cy DDC/TCA, Cameron Station, Alexandria, VA 22314

This report has been reviewed by the Information Office (IO) and is releasable to the National Technical Information Service (NTIS). At NTIS, it will be available to the general public, including foreign nations.

This technical report has been reviewed and is approved for publication.

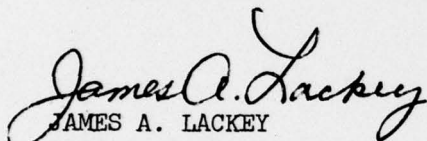
JAMES A. LACKEY
Project Engineer
Aero-Mechanical Division

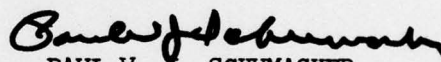
PAUL W. J. SCHUMACHER
Chief,
Aero-Mechanical Division

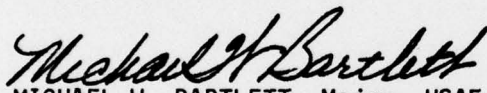
MICHAEL W. BARTLETT, Major, USAF
Assistant Director
Flight Test Engineering

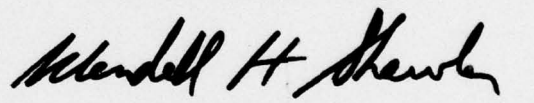
WENDELL H. SHAWLER, Colonel, USAF
Vice Commander, 4950th Test Wing

Copies of this report should not be returned unless return is required by security considerations, contractual obligations, or notice on a specific document.

REPORT DOCUMENTATION PAGE		READ INSTRUCTIONS BEFORE COMPLETING FORM
1. REPORT NUMBER ASD-TR-77-8	2. GOVT ACCESSION NO.	3. RECIPIENT'S CATALOG NUMBER
4. TITLE (and Subtitle) Military Transport (C-141) Fly-By-Wire Program	5. AUTHOR(S) James A. Lackey	6. TYPE OF REPORT & PERIOD COVERED Final Rept. Sep 72 - May 74
7. PERFORMING ORGANIZATION NAME AND ADDRESS Honeywell Inc. Minneapolis, Minnesota Flight Dynamics Laboratory (AFSC) Wright-Patterson AFB, Ohio 45433	8. CONTRACT OR GRANT NUMBER(s) Honeywell F33615-71-C-1286	9. PERFORMING ORG. REPORT NUMBER
10. CONTROLLING OFFICE NAME AND ADDRESS Aeronautical Systems Division (AFSC) 4950TW/FFMS Wright-Patterson AFB, OH 45433	11. REPORT DATE MARCH 1977	12. NUMBER OF PAGES 54
13. MONITORING AGENCY NAME & ADDRESS (if different from Controlling Office)	14. SECURITY CLASS. (of this report) UNCLASSIFIED	15. DECLASSIFICATION/DOWNGRADING SCHEDULE
16. DISTRIBUTION STATEMENT (of this Report) Approved for public release; distribution unlimited		D D C RECEIVED NOV 3 1977 RECEIVED B
17. DISTRIBUTION STATEMENT (of the abstract entered in Block 20, if different from Report)		
18. SUPPLEMENTARY NOTES		
19. KEY WORDS (Continue on reverse side if necessary and identify by block number) Fly By Wire Flight Test Flight Control Systems Flying Qualities		
20. ABSTRACT (Continue on reverse side if necessary and identify by block number) The C-141 Fly-By-Wire Test Program was an in depth study of the control laws and parameters governing large transports handling qualities. The test aircraft was C-141A S/N 61-2779 belonging to the 4950th Flight Test Wing, Wright-Patterson Air Force Base, Ohio. This aircraft was modified to include a dual redundant Fly-By-Wire Flight Control System in parallel with the standard manual flight control system. The aircraft was flown using a side stick controller located on the copilot's right armrest. The FBW Flight Control System was a two axes		

008800

1/B

UNCLASSIFIED

SECURITY CLASSIFICATION OF THIS PAGE(When Data Entered)

20. Continued.

system, pitch and roll. No yaw control was provided, except through the auto-pilot, where coordinated roll to yaw inputs to the FBW Flight Control System were made.

The C-141 FBW system had three modes of operation; a rate command mode and two attitude hold modes, attitude command and control-stick steering. ←

The FBW Control Parameters were maintained and varied manually at the control electronics assembly. Optimum control parameters were identified for all flight regimes.

The C-141 FBW system was flown a total of 63.6 hours during the flight testing. The system's performance was outstanding, no failures or malfunctions occurred. The test system was also insensitive to small parameter and airspeed changes. The evaluation pilots enjoyed the precision of control and the decreased workload that is usually not associated with flying large transport aircraft.

ACCESSION	197
NTIS	✓
DDC	
ORAM	
JUSTI	
BY	
DISTRIBUTION	
Dist.	AVAIL.
A	

UNCLASSIFIED

SECURITY CLASSIFICATION OF THIS PAGE(When Data Entered)

FOREWORD

This Report contains the flight test results of the "Military Transport (C-141) Fly-By-Wire Program", Project Number 8225(605). This Test was accomplished by the 4950th Test Wing, Aeronautical Systems Division, Air Force System Command at the request of the Air Force Flight Dynamics Laboratory, Wright-Patterson Air Force Base, Ohio.

Flight tests were performed at Wright-Patterson Air Force Base during the periods, 15 September to 5 October 1972 and 14 August to 24 October 1973. Flight testing was directed by James A. Lackey, Test and Evaluation Branch, Test Engineering Division, 4950th Test Wing. Captain Laurence D. Roberts, Control Systems Development Branch, Flight Controls Division, Flight Dynamics Laboratory managed the overall program. Contractor assistance was provided by Howard B. Larson, Systems Engineer, representing Honeywell Inc. Government and Aeronautical Products Division, Minneapolis, Minnesota.

This technical report has been reviewed and is approved.

TABLE OF CONTENTS

SECTION		PAGE
I	INTRODUCTION	1
II	TEST DESCRIPTION	3
	Test System Components	3
	Interface With Aircraft	11
	Instrumentation	11
	Safety Features	12
III	TEST PROCEDURES	14
	Phase I System Checkout	14
	Phase II System Development	14
	Phase III System Evaluation	15
	Phase IV System Demonstration	15
IV	TEST RESULTS AND DISCUSSIONS	16
V	CONCLUSIONS	20
VI	RECOMMENDATIONS	21

LIST OF ILLUSTRATIONS

Figure		Page
1	C-141 FBW Systems Components	22
2	C-141 FBW Side Stick Controller	23
3	C-141 FBW Side Stick, Mount, and Seat	24
4	Modified C-141 Control Wheel (Right Hand Grip Removed)	25
5	C-141 Pilot's Control Panel	26
6	Location of FBW Components in C-141	27
7	C-141 FBW Control Electronics Assembly	28
8	C-141 FBW Pitch Axis Analytical Block Diagram	29
9	C-141 FBW Roll Axis Analytical Block Diagram	30
10	C-141 FBW Test System Console	31
11	C-141 FBW Rate Gyro Assemblies	32
12	C-141 Vertical Accelerometers	33
13	C-141 FBW MG55T Servos and Linkage Assembly	34
14	C-141 FBW Auxiliary Display Panel	35
15	C-141 FBW Variable Gain and Time Constant Box	36
16	C-141 Roll Crossfeed Wiring Diagram	37
17	C-141 FBW Evaluation Pilots	38
18	C-141 FBW Standard Mission Profile	39 & 40

LIST OF ILLUSTRATIONS (cont'd)

Figure		Page
19	Project Pilot Flying Manual Maneuvers	41
20	Project Pilot Flying Maneuvers ATT OFF	42
21	Project Pilot Flying Maneuvers ATT CSS	43
22	Project Pilot Flying Maneuvers ATT CMD	44
23	Subject Pilot Flying Approach No. 1 ATT OFF	45
24	Subject Pilot Flying Approach No. 2 ATT CSS	46
25	Subject Pilot Flying Approach No. 3 ATT CMD	47
26	Subject Pilot Flying Approach and Landing	48

LIST OF TABLES

<u>TABLE:</u>		PAGE
1	Instrumentation Parameters	49 & 50
2	Final Parameter Gains	51
3	Cooper-Harper Rating Of FBW	52
4	Pilot Experience	53
5	Mode Preference For FBW	54

SECTION I

INTRODUCTION

A generally accepted definition of a Fly-By-Wire (FBW) flight control system is an electrical primary flight control system that employs feedback such that aircraft motion is the controlled parameter. From a standpoint of safety and economy, a pure Fly-By-Wire flight control system for the test aircraft was beyond the scope of this program. Instead a pseudo Fly-By-Wire flight control system was selected. This system contained the standard manual flight control system in addition to the FBW system. The manual flight controls remained whole and intact for the duration of this test program.

The Lockheed C-141 Starlifter was selected for this program because it was the mainstay aircraft of the Military Airlift Command, it is dynamically stable, and FBW technology had not previously been applied to a large military transport aircraft.

FBW offered several advantages over manual flight systems and for C-141 application, improved aircraft handling qualities would be the most significant. For an aircraft that is designed for a FBW flight control system instead of the complicated, non-linear mechanical system of cables and linkages. Through the use of side stick controllers, the cockpit layout would be much more flexible and the pilot's view of the instrument panel improved by removing the control wheel and column. Automatic landing systems and stability augmentation systems could easily be

incorporated into the FBW control electronics. The FBW flight control system could have three or four channel redundancy achieving the reliability unmatched by a hydra-mechanical system.

The need for more advanced flight control systems has slowly evolved since WW-II. Larger and heavier aircraft were flying subsonic, transonic, and eventually supersonic. As flying envelopes expanded, cable control systems became inadequate. Modifications included power boosted controls and finally, fully powered flight control systems, involving complicated non-linear linkages to provide aircraft control¹. These flight control systems also incorporated artificial "feel" systems to again give the pilot a "feel" for the handling of the aircraft.

Control and stability augmentation systems resulted when aircraft motion information was fed into the flight control system to dampen unwanted or oscillatory motion. The next inevitable step was the FBW flight control system which eliminated many of the disadvantages incurred through the evolution of the flight control system.

The objectives of this C-141 FBW program were to investigate the flight performance and handling qualities of a large transport type aircraft. The Fly-By-Wire control parameter gains were optimized according to airspeed and the aircraft handling characteristics were evaluated for each of the mission tasks (approach and landing, simulated refueling and paradrops, and cruise maneuvering). Furthermore the FBW flight control system was introduced to and evaluated by many Air Force pilots which demonstrated the current FBW technology to potential users.

1. Jenney Gavin D., Research on Flight Control Systems Fly-By-Wire B-47 Phases II and III. Technical Report AFFDL-TR-69-119, Volume II Wright-Patterson AFB, Ohio. Air Force Flight Dynamics Laboratory, August 1970.

SECTION II

TEST DESCRIPTION

The C-141 FBW flight control system was a two axes (pitch and roll) electrical primary flight control system designed to operate parallel to the standard flight control system. The FBW system was a dual channel system providing redundant electronic control circuits (Figure 1). These circuits were automatically compared while the system was operating by monitoring circuitry within the system which would disengage the FBW system if disagreement between the two channels occurred. This flight control system was developed by the Aerospace Division of Honeywell, Inc., Minneapolis, Minnesota, under contract with the Air Force Flight Dynamics Laboratory, Wright-Patterson Air Force Base, Ohio.

FBW TEST SYSTEM COMPONENTS

Side Stick Controller

A side stick controller (Figure 2) was used for pilot inputs to the FBW flight control system. The side stick was mounted on the right hand side of the copilot's seat (Figure 3), replacing the right armrest. The copilot's control wheel and column, which remained in the aircraft, was modified by removing the right hand grip (Figure 4). This was performed to prevent the wheel from striking the side stick controller, since the control column movement reflected the control surface deflection. The side stick mount was fully adjustable in all three axes and was able to fit any preference or pilot size.

The side stick controller was developed by Honeywell for NASA's space vehicle application. Honeywell modified existing hardware to meet C-141 FBW requirements. The hand grip on the side stick controller was a Navy F-8

Guardian hand grip which had been modified to include the roll and pitch trim verniers for FBW pre-engage alignment. The hand grip also included a two-detent trigger (one of the detents provided for an emergency FBW disengage.)

Pilot's Control Panel

The pilot operated the FBW system using the control panel (Figure 5). The control panel was located on the right side of the control pedestal (Figure 6) and replaced the unused mach trim compensator panel. The control panel contained a toggle switch that was used to select any one of the three FBW modes; Attitude Off, Attitude Command, and Attitude Control Stick Steering. The control panel also contained roll and pitch trim indicators that presented the misalignment between the FBW system and the mechanical flight control system. Before FBW could be engaged, the misalignment was nulled by using the trim verniers located on the side stick.

The pilot's control panel also contained a 2-position, solenoid-operated switch, which allowed the pilot to select NSS (Neutral Speed Stability) or PSS (Positive Speed Stability). Selection of either NSS or PSS, in conjunction with the autotrim function of the FBW system, entailed different methods of trimming the aircraft. The autotrim engagement switch was located on the control electronics assembly and was activated by the test personnel monitoring the console, (NSS/PSS inputs were fed to the FBW elevator servos). Autotrim inputs were fed to the servo driving the horizontal stabilizer. If the FBW autotrim was turned "off", the aircraft was automatically trimmed by signal inputs to the

FBW elevator servos, providing "NSS" had been selected at the pilot's control panel. If the pilot had selected "PSS", the aircraft would then be trimmed manually. With FBW autotrim turned "on", the aircraft was again automatically trimmed if "NSS" had been selected; but the autotrim drove the horizontal stabilizer to a trimmed position, which cancelled out any elevator deflection required for trimmed flight. If "PSS" was selected with autotrim "on" a pilot side stick input was required for trimmed flight until the autotrim function drove the horizontal stabilizer to the trimmed position. The majority of the flight testing was performed with autotrim "on" and NSS selected.

The solenoid of the PSS/NSS switch was connected electrically to the C-141 touchdown circuitry in such a way that prevented operation of the NSS mode while the aircraft was on the ground. This prevented the automatic trimming of the aircraft during touchdown, roll out, or takeoff, insuring that the pilot had complete control of the pitch axis.

The control panel also contained two comparison monitoring lights, one for roll and the other for pitch, which were controlled by the control electronics assembly servo comparison monitoring logic. A light was illuminated whenever the appropriate axis was disengaged, by either system failure or servo misalignment. Resetting the control electronics assembly logic and re-engaging FBW extinguished the light.

Control Electronics Assembly

The control electronics assembly (Figure 7) contained all the electronic circuitry needed to mechanize the FBW system. This included the dual-channel inner-loop computation, the single-channel outer loop

computation, servo amplifier monitoring, and engage logic. The control electronics assembly (CEA) provided for FBW disengagement by two redundant "G"-Limited circuits, which disengaged FBW upon encountering excessive "G"-Loadings, and the monitoring circuit which also disengaged FBW if corresponding parameters in the dual flight control circuits differed by a preset amount. On the left side of the panel, dual-channel (A and B) power "on/off" switches controlled the 115 volts 400 Hz and 28 VDC power entering the CEA. Fifteen 10-turn potentiometers, located in the center of the panel, provided the variable settings for the control law parameters (Figures 8 and 9). Test input and autotrim switches were located on the right side of the CEA. The test input switch was a single-pole, double-throw, center off, toggle switch which provided a \pm variable DC input through an additional 10-turn potentiometer. The input was used for pre-flight testing and in-flight testing for obtaining aircraft step responses. When the autotrim function was engaged, the aircraft was trimmed through the movement of the horizontal stabilizer. This movement was controlled by the FBW pitch servo information and always trimmed the stabilizer so as to unload the FBW pitch servos. With the autotrim in the "off" position, the pilot trimmed the aircraft manually through the hydraulic stabilizer trim system. At the far sides of the panel, a total of 56 test points were located. These points provided the test engineer with the capability of monitoring pertinent FBW information, servo operation, and sensor inputs.

The CEA was installed on the test system console (Figure 10) located at the forward end of the cargo compartment. Also located on the console was the oscillograph, Honeywell #1108 visicorder and auxiliary display panel.

The FBW flight control system was engaged manually by placing both power switches on the CEA in the "on" position and the engage switch on the pilot's control panel in the "engage" position.

The pilot selected anyone of three FBW modes: attitude off (ATT OFF), attitude command (ATT CMD), or attitude control-stick steering (ATT CSS), by positioning the toggle switch located on the pilot's control panel to the appropriate indicated position. Additionally, he was able to change modes without having to disengage Fly-By-Wire or introducing any transients into the flight control system.

Rate Command mode (Attitude OFF). This mode was similar to the operation of the standard mechanical flight control system, (i.e. stick back gives pitch up, stick left gives left roll, etc.) except that the FBW system commanded aircraft motion, not control surface deflection. For example, fore or aft movement on the side stick commanded a given aircraft pitch rate, not a given elevator deflection angle. Servo command signals were generated by the CEA from side stick and feedback (vertical acceleration, pitch and roll rates) input signals.

Attitude Command mode (ATT/CMD). This mode was one of two FBW attitude-hold modes. In this mode the FBW system enabled direct side stick command of pitch and roll attitude, using the aircraft attitude at the time of mode engagement as a reference. Position of the side stick corresponded to a given aircraft attitude, and when the side stick was returned to the neutral position, the aircraft returned to the attitude present at the time of mode engagement.

Attitude Control Stick Steering mode (ATT/CSS). This was the other FBW attitude-hold mode. In this mode, side stick movement commanded pitch and roll rates, but when the side stick was returned to neutral position, the attitude-hold mode was engaged, maintaining the aircraft attitude sensed at that time, until the side stick was again displaced from the neutral position.

Rate Sensors

Pitch and roll rate information was provided by two GFE F-111 GE756D516G1 rate gyro assemblies (Figure 11.) These two gyros were mounted on the avionics shelf located below the flight deck. Each gyro assembly provided one channel of pitch and roll information to the CEA.

Accelerometers

Vertical acceleration information was provided by two identical Honeywell GG47A-2 accelerometers (Figure 12) located below the cockpit. Each accelerometer provided one channel of information to the CEA. These inputs were used to determine C* and provide the "G"-limit disengage circuit with information. C* was a term developed by the Boeing Company and has proved to be a convenient method for mechanizing the

flight control system feel/response. C* represents a linear blend of vertical acceleration at the cockpit, pitch rate, and pitch acceleration. The pilot's side stick commands were summed against C* feed back; therefore, pilot inputs from steady-state initial conditions were effectively C* commands.

Hydraulic Servos

Four MG55T hydraulic servos transformed the FBW system electrical output signals into mechanical input commands for the control surface power actuators. Two servos and the associated whiffle-tree and linkages (Figure 13) were mounted in the vertical stabilizer and provided redundant inputs to the elevator control input quadrant. Dual redundant servos were likewise mounted in the center wing section to provide inputs into the aileron control quadrant.

All four FBW servos received their hydraulic power from the aircraft's No. 3 hydraulic system, which is an emergency back-up system. Working pressure for the hydraulic system was 3000 psi.

Auxiliary Display Panel

The FBW test system engineers monitored the auxiliary display panel (Figure 14) located on the test system console installed in the forward cargo area. The auxiliary display panel contained altitude, airspeed, and roll and pitch trim indicators, in addition to the time code display. Two DC voltmeters were also located on the panel and were used to monitor any of the CEA test points. The AR-200 tape recorder was operated remotely (started, stopped, and calibrated) from the auxiliary display panel. An event marker was also located on the panel. A series

of indicator lights informed test personnel as to the status of FBW. These lights included: FBW engage, the FBW mode the pilot was flying, and PSS engage. Nose up and nose down trim lights were provided so the auto trim function could be observed. The roll crossfeed function was also operated from the auxiliary test panel. A solenoid switch engaged the auto pilot roll-to-yaw crossfeed function and a status light confirmed engagement. The roll crossfeed function was operable only when FBW was engaged because the roll crossfeed circuit had been tied into the CEA FBW engage logic.

Vertical Gyro

The C-141 aircraft FBW system used the standard C-141 autopilot vertical gyro. Additional wiring from the vertical gyro to the CEA provided the FBW system with pitch, roll, and roll versine ($1 - \cos(\text{angle})$) information.

Acceleration Variable and Gain Box

This variable gain and time constant box (Figure 15) was constructed to experiment with the normal acceleration signals received from the cockpit accelerometers. The signal gain was varied from 0 to 0.7 percent through the potentiometer located on the box. The toggle switches activated the circuit and controlled the time constant from 0.05 sec. to 0.35 sec. in 0.05 sec. steps by turning the appropriate switch(es) on. The box was patched into the CEA card test points before each mission and removed after each mission.

FBW INTERFACE WITH AIRCRAFT

FBW Electrical Power

Electrical power was supplied to the FBW flight control system through the test bed power system. The master test power switch located above the pilot's head controlled all electrical test power, 28 VDC, 115V 400 Hz and 115V 60 Hz. When activated, this switch connected the test bed power to the main aircraft buses. The test power distribution "J" box was located in the forward cargo section station 614 and contained all the FBW circuit breakers.

Roll-To-Yaw Crossfeed

After the first initial test flights it became apparent that the yaw damper was fighting the FBW roll commands. This problem was solved by including the autopilot's roll-to-yaw crossfeed information into the FBW flight control system. Changes were made to the aileron computer, yaw damper, autopilot junction box, autopilot coupler, and the FBW CEA. The modification (Figure 16) allowed the FBW roll-to-yaw crossfeed function to operate in parallel with the standard C-141 aircraft's autopilot. Coordinated rudder and aileron turns were now possible with FBW engaged and the standard C-141 aircraft autopilot's performance remained unaffected.

INSTRUMENTATION

The instrumentation consisted of an Ampex AR-200 tape recorder and the associated amplitude and frequency conditioning units. Fifty parameters (Table 1) were recorded on tape using nine tracks. Up to eight parameters per track were multiplexed onto the one-inch wide mylar.

magnetic tape. Tape speed was 7.5 inches per second. The tape recorder, No. 1 signal conditioning box, associated voltage controlled oscillator (VCO) rack, and time code generator were located in an instrumentation rack installed in the aft portion of the flight deck. Also on the flight deck, at the navigator's table, the program manager observed pilot duties, evented test procedures and recorded pilots' comments. The number two signal conditioning box and associated equipment was located on the bottom shelf of the test system console. Further signal monitoring and analysis was accomplished using a Honeywell 1108 Visicorder and a Techtronics 453 Dual Trace Oscilloscope. This equipment was located in the test system console and monitored by the test system engineer.

SAFETY FEATURES

The C-141 aircraft's FBW flight control system was designed to be a safe flight control system.² All system safety features were tested on the first test flights without producing a failure. Nevertheless, the FBW system could be quickly and easily disconnected (or disengaged) if a malfunction was suspected, and the aircraft could be controlled by the standard flight control system.

The FBW flight control system provided for the following safety disconnects: Electrical disengage trigger switches were located on the pilot's and copilot's control wheels. The master test power switch, located above the pilot's head, could be turned off, eliminating all test

2. Sutherland, J.P. Major CAF, Fly-By-Wire Flight Control Systems, Paper given at Joint Meeting of Flight Mechanics and Guidance and Control Panels of A.G.A.R.D.; Oslo, Norway, September 1968, Air Force Flight Dynamics Laboratory, Wright-Patterson AFB, Ohio.

power. The pilot or copilot could disengage the FBW system at the pilot's control panel. The test system engineer disengaged FBW by removing power from both channels of the CEA. The FBW circuit breakers could be pulled, interrupting power from the distribution box to the FBW test panels. The servo comparison monitoring circuits disengaged FBW in the axis where servo displacement disagreed by a preset amount. This type of disengagement occurred often during an ILS approach and was more of a nuisance disengage than a malfunction. For example, if the aileron servos reached their displacement limits at different times, the monitoring circuits detected the misalignment and automatically disengaged FBW in the roll axis. The FBW flight control system also contained a "G" limit disengage circuit that was preset to disengage FBW at + 1.5 G or - 1.0 G. The flight engineer disengaged FBW by shutting down No. 3 hydraulic system thus preventing any hydraulic power from actuating the FBW servos. If for any reason the automatic or manual disengages malfunctioned, the pilot could overpower the FBW servos, which had been preset for a maximum force of ± 65 lbs in pitch or ± 30 lbs in roll. The last mechanical link between the FBW system and the standard flight control system was severed when the pilot applied enough force to shear the pin placed between the FBW servos and the aileron/pitch linkage to the power ram servo for the control surface.

SECTION III
TEST PROCEDURES

The testing of the FBW flight control system consisted of two flying periods, the first period of testing took place between 15 September and 5 October 1972. The second period of flying, 14 August to 24 October 1973, was performed under the restricted requirements of PDM scheduling and allotted flying hours remaining on the aircraft. As a result, the simulated manual terrain tracking mission was not performed. Twenty-two missions were flown totaling 63.6 flight hours and resulted in the following phases:

PHASE I - SYSTEM OPERATIONAL CHECKOUT (Three Flights)

The first flight was devoted to the system safety checkout which included the manual and automatic FBW disengage functions. The next two flights verified the correct operation of the basic FBW modes: ATT OFF, ATT CSS, ATT CMD. The FBW system did not experience any malfunctions for these checks and was very docile in controlling the aircraft.

PHASE II - SYSTEM DEVELOPMENT (Six Flights)

Originally the largest number of missions were planned for optimizing the various parameter gains and time constants. As testing got underway this proved unnecessary and the gains (Table 2) were finalized in six flights. The gains were optimized for three airspeeds which covered the operating envelope of the C-141: (A) 140 KCAS (B) 230 KCAS (C) 300 KCAS. Two test missions were devoted to recording the step responses for the three FBW modes at airspeeds of 140, 230, and 300 KCAS.

PHASE III - SYSTEM COMPARISON AND EVALUATION (Thirteen Flights)

This phase was allowed more test time as a result of the minimum time expended determining the parameter gains. Evaluations were performed by the Project Pilot, Major Richard Johns and thirteen other subject pilots (Figure 17). Each pilot was asked to complete the standard mission profile (Figure 18) and fly several ILS approaches, hopefully at least one in each mode. Upon completion of the test, the evaluating pilot completed a Cooper-Harper rating of the FBW flight control system (Table 3), which included rating each FBW mode. In addition to the instrument maneuvering and approaches, two other mission tasks were investigated; simulated paradrop and refueling. The FBW C-141 aircraft was flown in close formation with a KC-135 aircraft to simulate refueling, and with another C-141 aircraft to simulate the paradrop task.

PHASE IV - SYSTEM DEMONSTRATION

The C-141 FBW aircraft was demonstrated to the Military Airlift Command on a TDY trip to Scott AFB, IL. Two missions were flown: one mission was a short familiarization flight for General Robbins and the second flight was a full FBW evaluation by two MAC Pilots. After returning from these demonstration flights the aircraft had exhausted the flying hours remaining before PDM and no other FBW test missions were scheduled.

SECTION IV

TEST RESULTS AND DISCUSSION

The C-141 FBW flight test evaluation was a success. Twenty-five test missions were flown logging 63.6 hours. Seventeen pilots flew the C-141 flight control system (13 pilots performed evaluations while four made familiarization flights only). The C-141 aircraft FBW flight control system did not malfunction and there were no failures recorded during the flight testing program.

The evaluation pilots included two MAC line pilots and the remainder were 4950th flight test pilots. Pilot experience was quite varied as shown in Table 4. Every pilot that flew the FBW system recorded favorable comments on the system as a whole. Several pilots disliked the break-out forces on the side stick controller. The break-out forces were either too large or too small, indicating the personal preference of the pilot. Since it was not the objective of this program to develop the side stick controller, compromises were made in order to use off the shelf hardware whenever possible.

The pilots liked the decreased workload while flying the system, especially during formation flying and low approaches. Two formation flying missions were accomplished. Pilots expressed an equal mode preference between ATT OFF and CSS modes. Greater concentration and slightly higher workload were noticed for the ATT CMD mode, while achieving increased flying precision. Many pilots expressed the opinion that the precision by which the C-141 aircraft could be controlled at low airspeeds and during ILS approaches was impressive.

Manual and FBW maneuvers were performed according to the standard mission profile by the evaluating pilots. Figures 19 through 22 are excerpts from the data and show the project pilot performing a portion of the standard mission profile in the different FBW modes. Flying the different bank angles, heading and altitude changes was easy in any of the FBW modes, even when flying all three changes in the same maneuver. The data reveals that considerably more roll side stick deflection was required (for the same bank angle) in the ATT CMD mode than the ATT OFF or CSS mode. There was little roll stick activity in ATT CMD, while the side stick was constantly moving in the ATT OFF mode. This indicates that roll attitude hold was better in the CSS and ATT CMD modes.

The Cooper-Harper ratings reflected the pilot's best choice for up and away maneuvering was the control stick steering (CSS) mode. The worst choice for up and away maneuvering was the attitude command (ATT CMD) mode.

All three approaches as shown in Figures 23, 24, and 25 were flown by the same subject pilot. In comparing the data, the CSS mode demonstrated less stick activity in both roll and pitch attitudes than the other modes. Side stick deflection was also greater in CSS mode than in the other two modes. This indicates that the CSS mode was indeed working for the pilot by decreasing his side stick inputs and thus his workload. As would be expected the ATT OFF mode had the most side stick activity, not in just the roll attitude, but also in the pitch attitude.

A FBW approach and landing was attempted in ATT CMD by another subject pilot. The data traces are shown in Figure 26. The FBW system was disengaged by the project pilot just before touchdown because the subject pilot got behind the aircraft during flare. The project pilot then made an uneventful

touchdown and roll out. Note the increase in amplitude for the side stick pitch inputs prior to FBW disengage. The subject pilot was trying to fly a pitch rate (when he actually wanted a pitch attitude) for flare and over-compensated. Additional experience in the ATT CMD mode would have prevented the disengagement.

The Cooper-Harper ratings for the approach and landing phase did not indicate such a clear choice for a mode preference. The CSS mode received the most "BEST" ratings and also the most "WORST" ratings (Table 5). This indicated that much more time was needed to evaluate the modes for approach and landing. These ratings were based on an average of slightly more than one approach per mode for each evaluation pilot.

There were some small problems encountered with the FBW system. These problems did not effect the FBW missions either by reducing or canceling scheduled test missions and were considered more of a nuisance, since they did not reflect a system failure.

The first problem involved an automatic FBW disengage when the landing gear was retracted. This problem occurred at random during the flight testing and was finally traced to an electromagnetic interface problem in the landing gear relay logic circuit. The relay was identified and a diode was installed across the contacts to prevent any more FBW disengages.

The second FBW nuisance disengage problem involved the aileron servo linkages and the roll comparison monitoring circuit. Below 150 KCAS³, the C-141 exhibited poor roll response and as a result, during turbulent

3. McCabe, John M., Capt, USAF, Benefield, Tommie D., Major, USAF, C-141A Category II Stability and Control Test. Technical Report No. 66-5 Edwards AFB, California. Air Force Flight Test Center, June 1966.

or gusty low approaches, full aileron deflections were necessary while trying to give the FBW pilot the roll rates he had demanded with the side stick. Both FBW servos were driven to their stops, but did not reach the end of their respective travels simultaneously. The roll comparison monitoring circuit would sense this misalignment and disengage the FBW system. This problem was not solved because the project could not afford to lose the down time involved to make the modifications. The roll comparison monitoring circuit was not by-passed for safety reasons should one of the servos actually fail. The forward loop roll gains were reduced 20% to prevent the roll disengage from occurring quite so often.

SECTION V

CONCLUSIONS

The C-141 aircraft FBW flight control program proved the feasibility of using FBW techniques and technology for controlling large military transport aircraft.

The FBW flight control system as installed for this test program was reliable.

Pilot workload was decreased while flying in turbulence, performing ILS approaches, and formation flying.

The FBW flight control system, especially the side stick controller, allowed for precise control of the C-141 aircraft during ILS approaches and the flare and touchdown maneuvers.

SECTION VI
RECOMMENDATIONS

The logical recommendation that would follow a test project of this type would be to initiate a production FBW system for the next military transport being developed. This test, even though highly experimental and performed on a low key, proved that the Air Force Flight Dynamics Laboratory and the Contractor, Honeywell Inc., possess the necessary technology for such a system. The aircraft's performance objectives and the FBW flight control system should be integrated towards fulfilling the mission requirements of the aircraft.

FBW flight control subsystems, control augmentation systems (CAS) and stability augmentation systems (SAS) are making their way into the present military and commercial flight control systems through the autopilot. This action is costly and time consuming. The autopilot system is made more complex resulting in reliability and maintainability problems. The logical choice is a complete FBW flight control system resulting in a simpler and less expensive flight control system to fly and maintain.

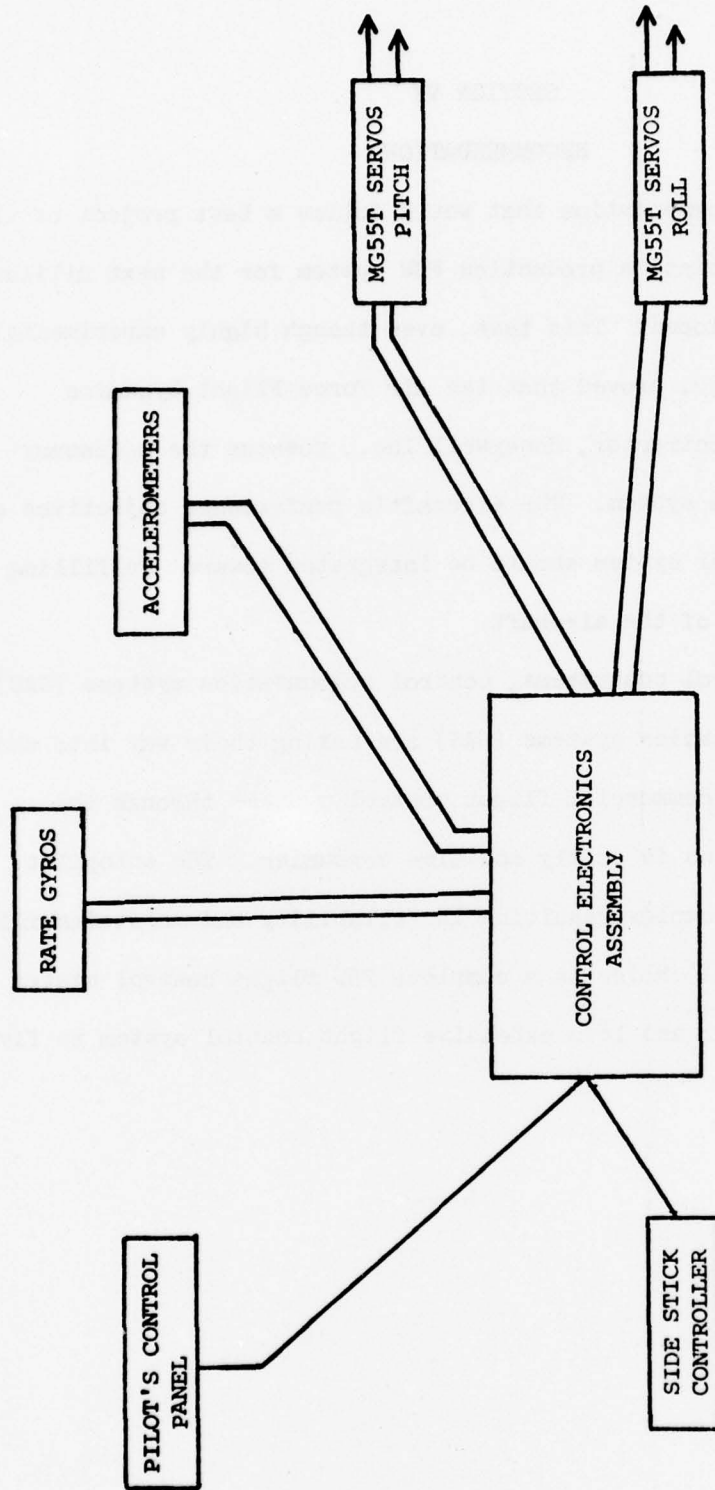

Figure 1. C-141 FBW System Components

C-141 FBW SIDESTICK CONTROLLER

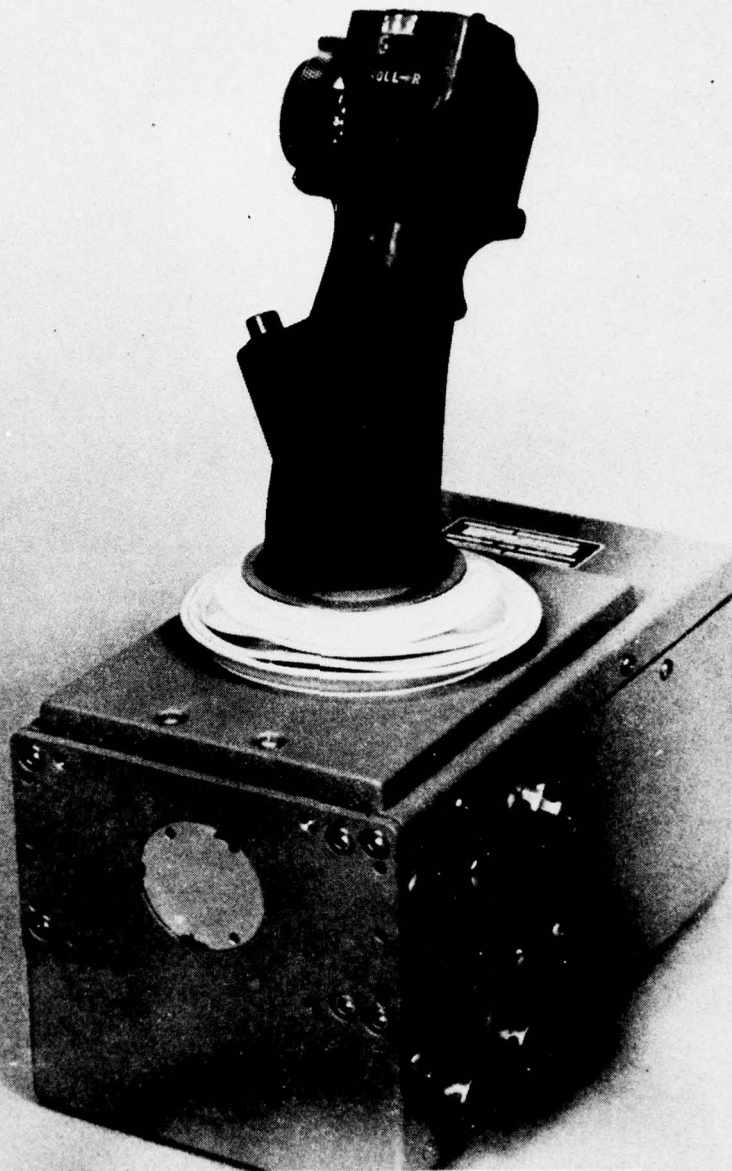

Figure 2. C-141 FBW Sidestick Controller

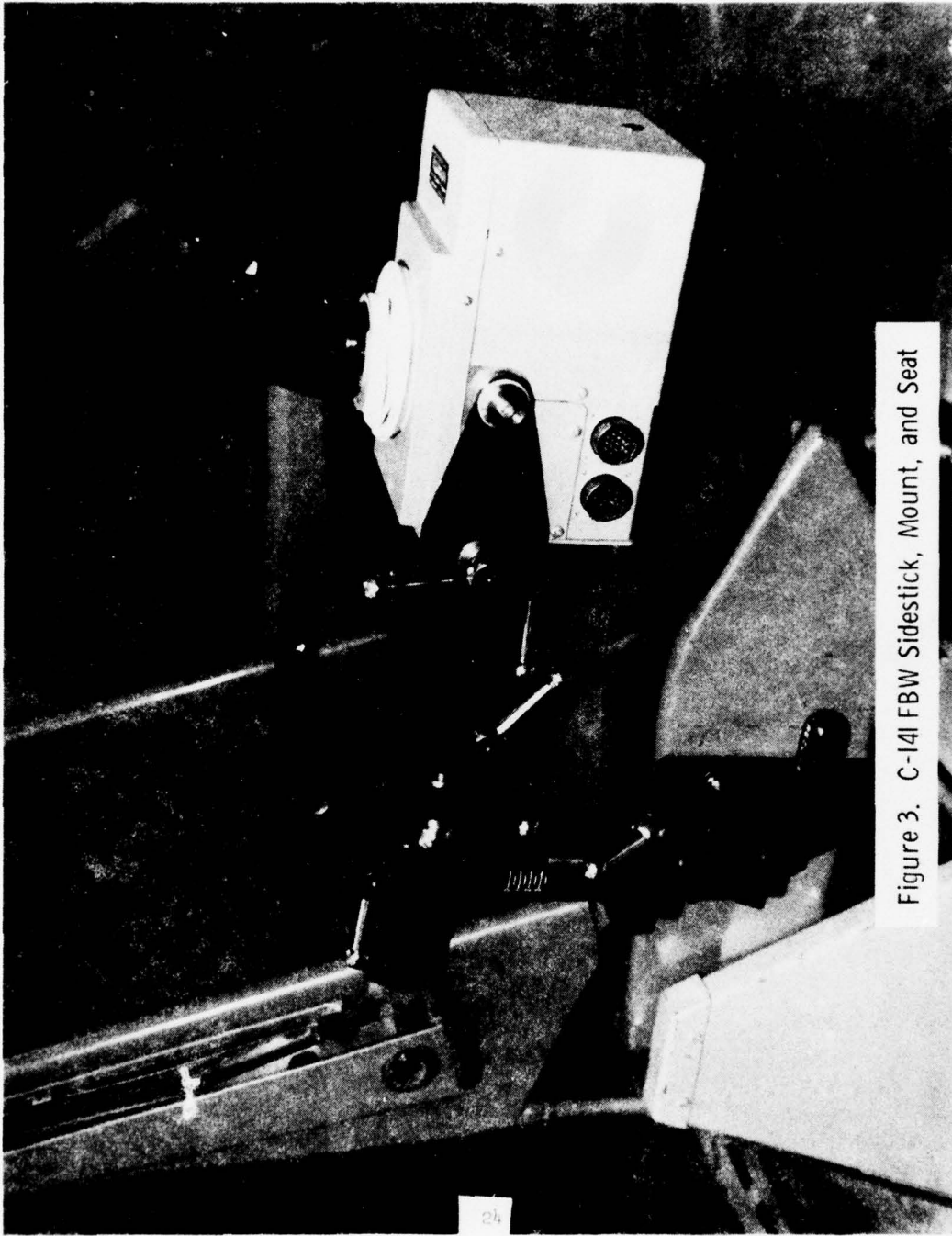

Figure 3. C-141 FBW Sidestick, Mount, and Seat

24

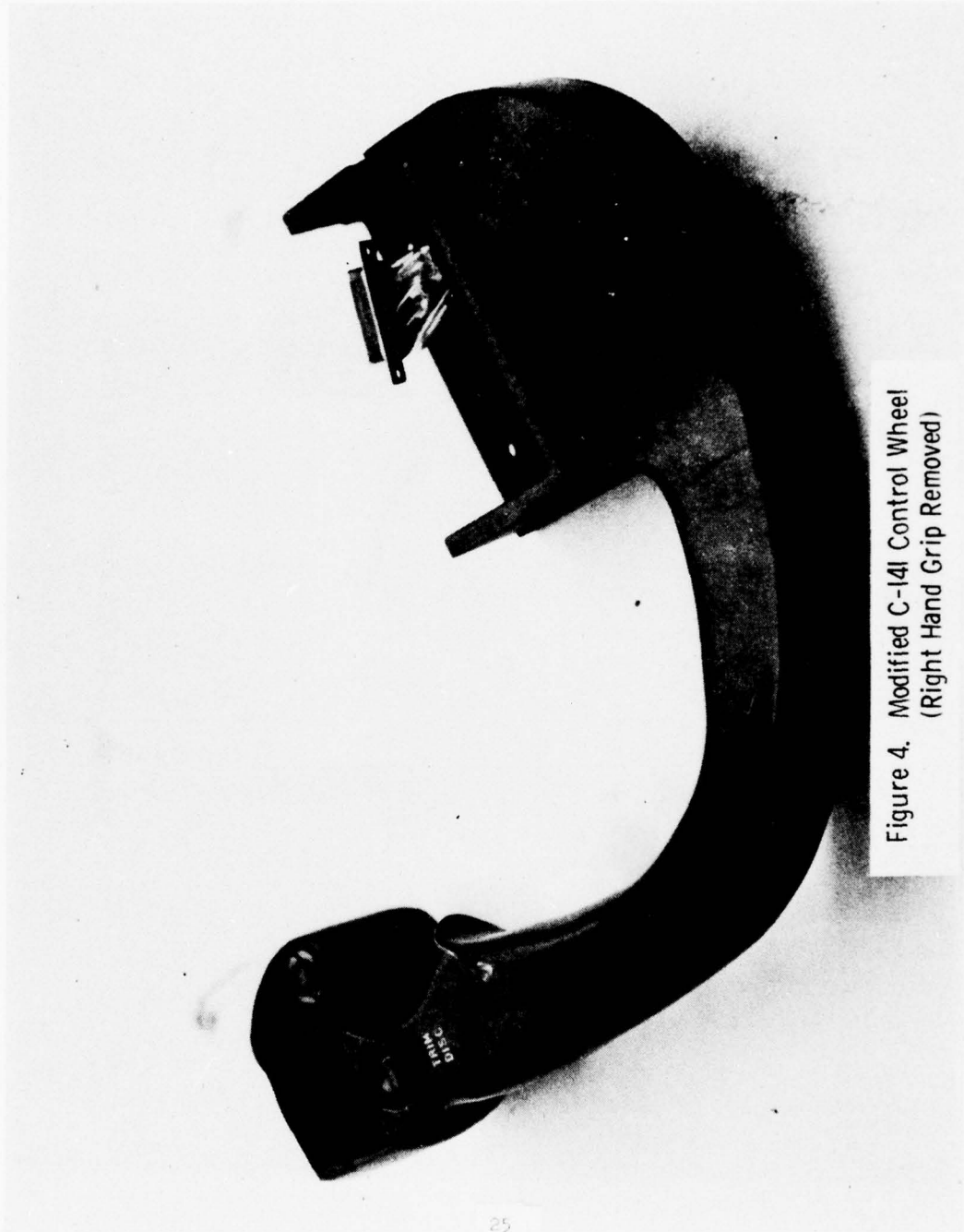

Figure 4. Modified C-141 Control Wheel
(Right Hand Grip Removed)

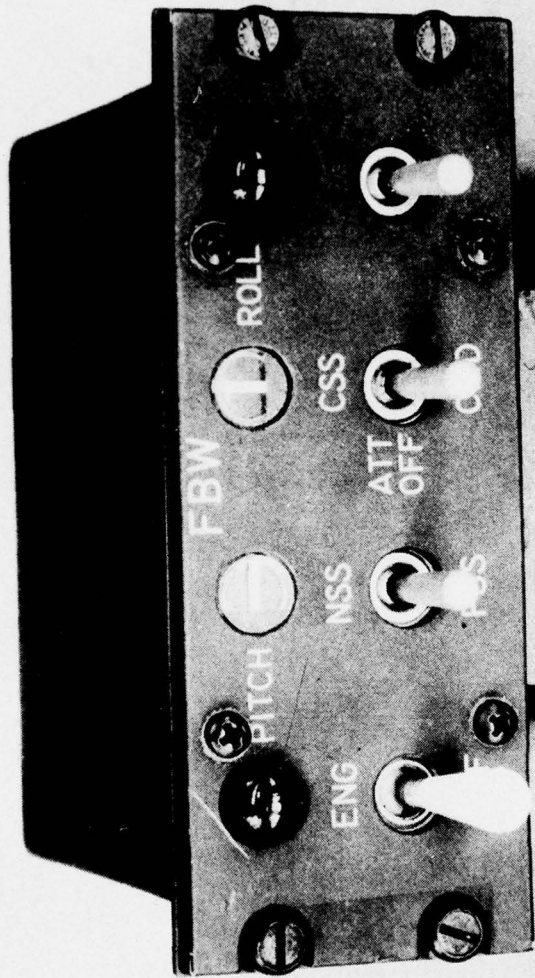
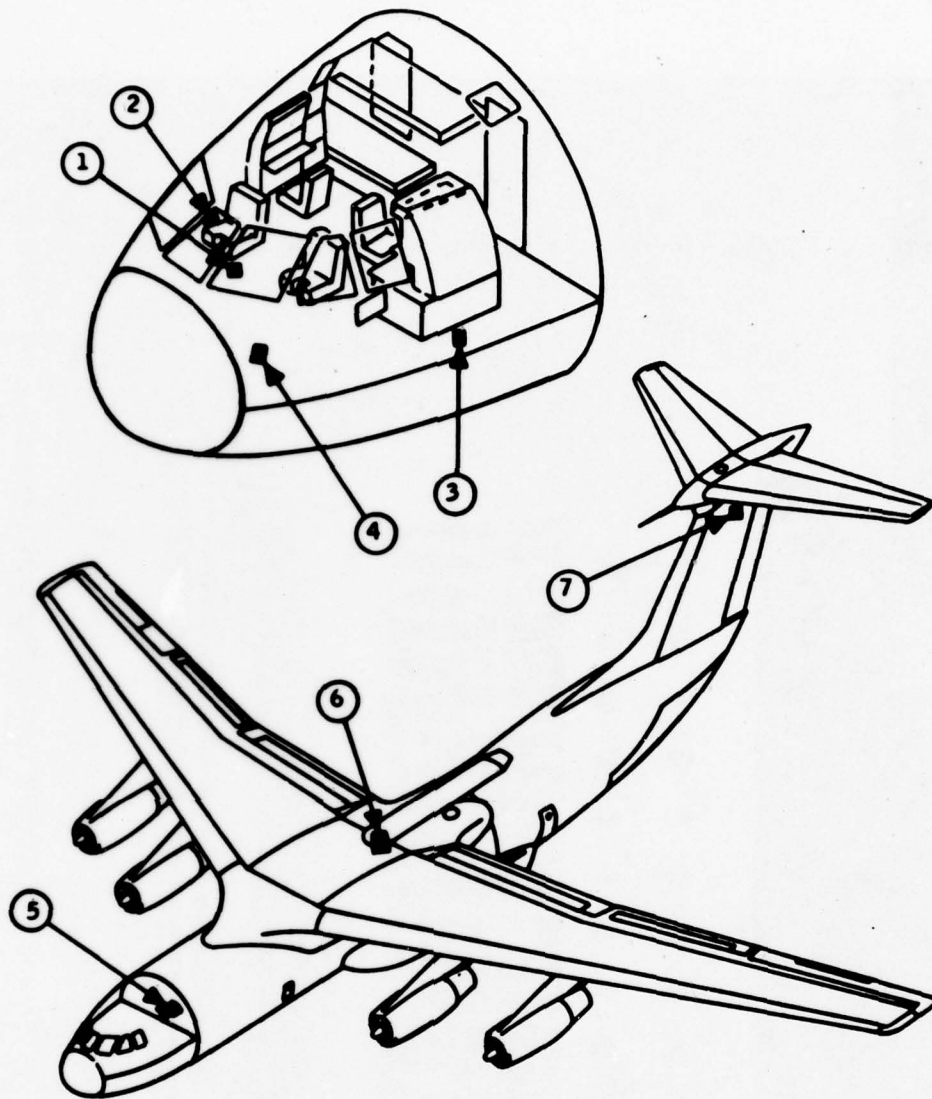

Figure 5. C-141 FBW Pilot's Control Panel



- (1) PILOT'S CONTROL PANEL
- (2) SIDE-STICK CONTROLLER
- (3) RATE GYROS
- (4) ACCELEROMETERS
- (5) TEST SYSTEM CONSOLE
- (6) AILERON CONTROL SERVOS
- (7) ELEVATOR CONTROL SERVOS

Figure 6. Location of FBW Components in C-141

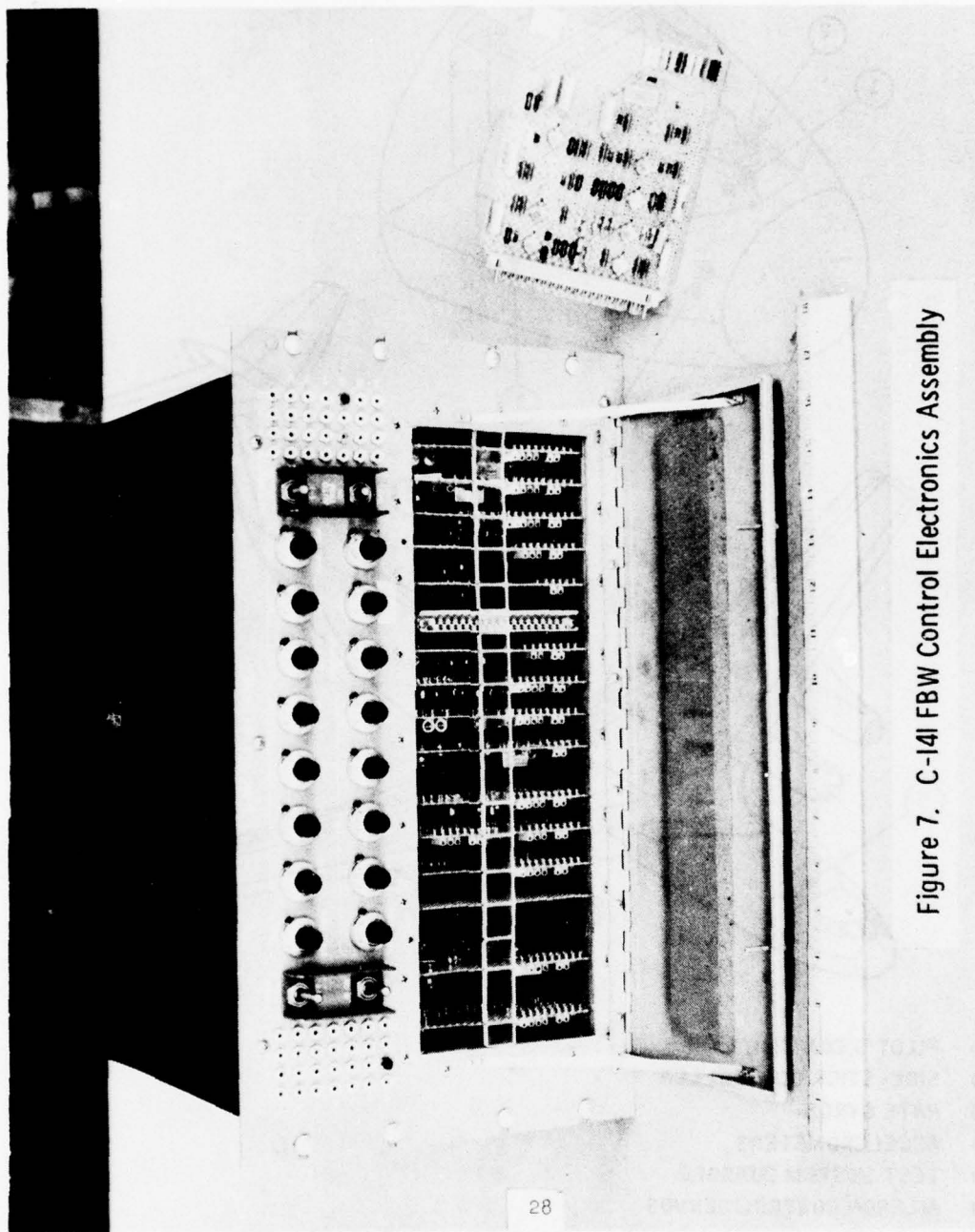

Figure 7. C-141 FBW Control Electronics Assembly

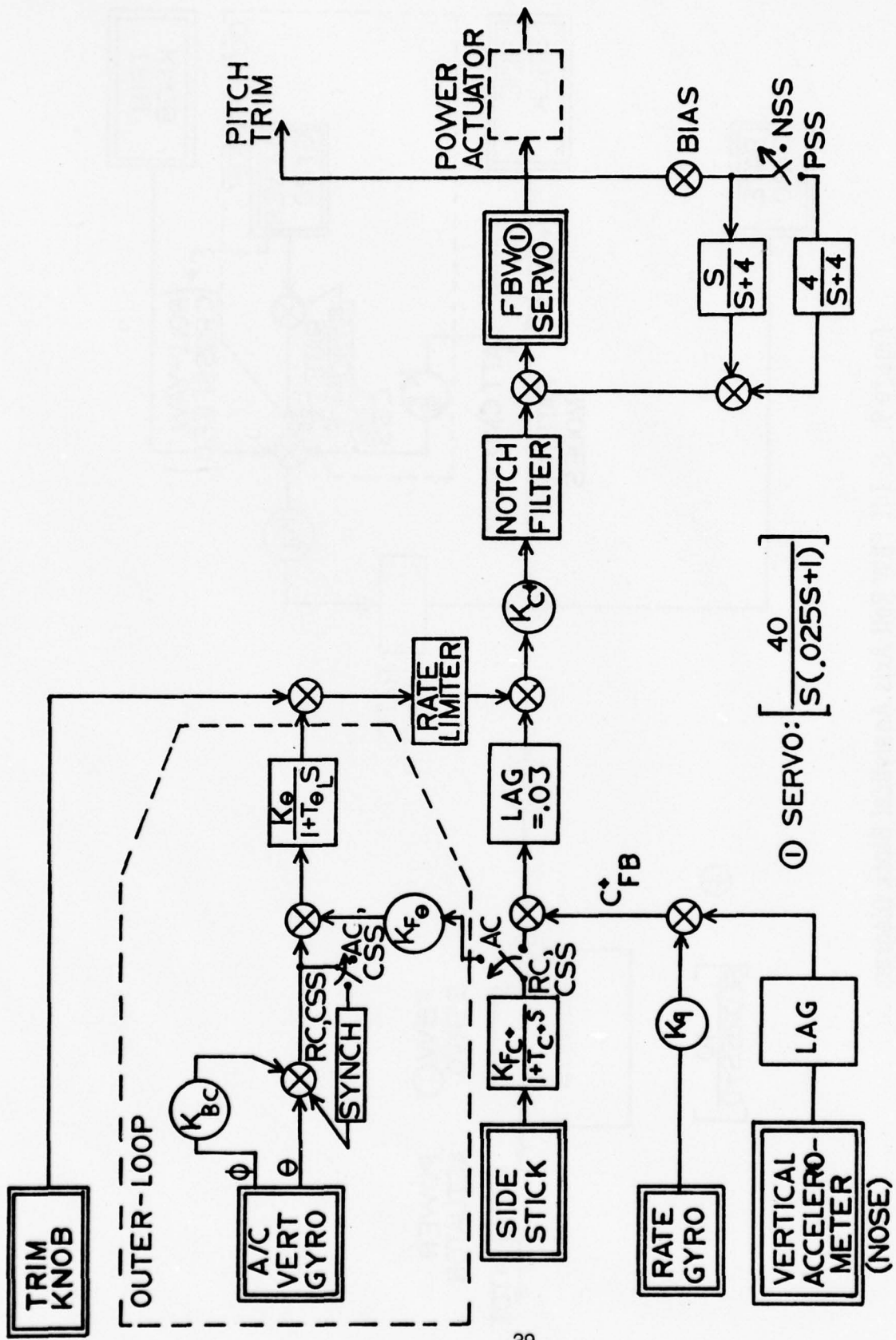

Figure 8. C-141 FBW Pitch Axis Analytical Block Diagram

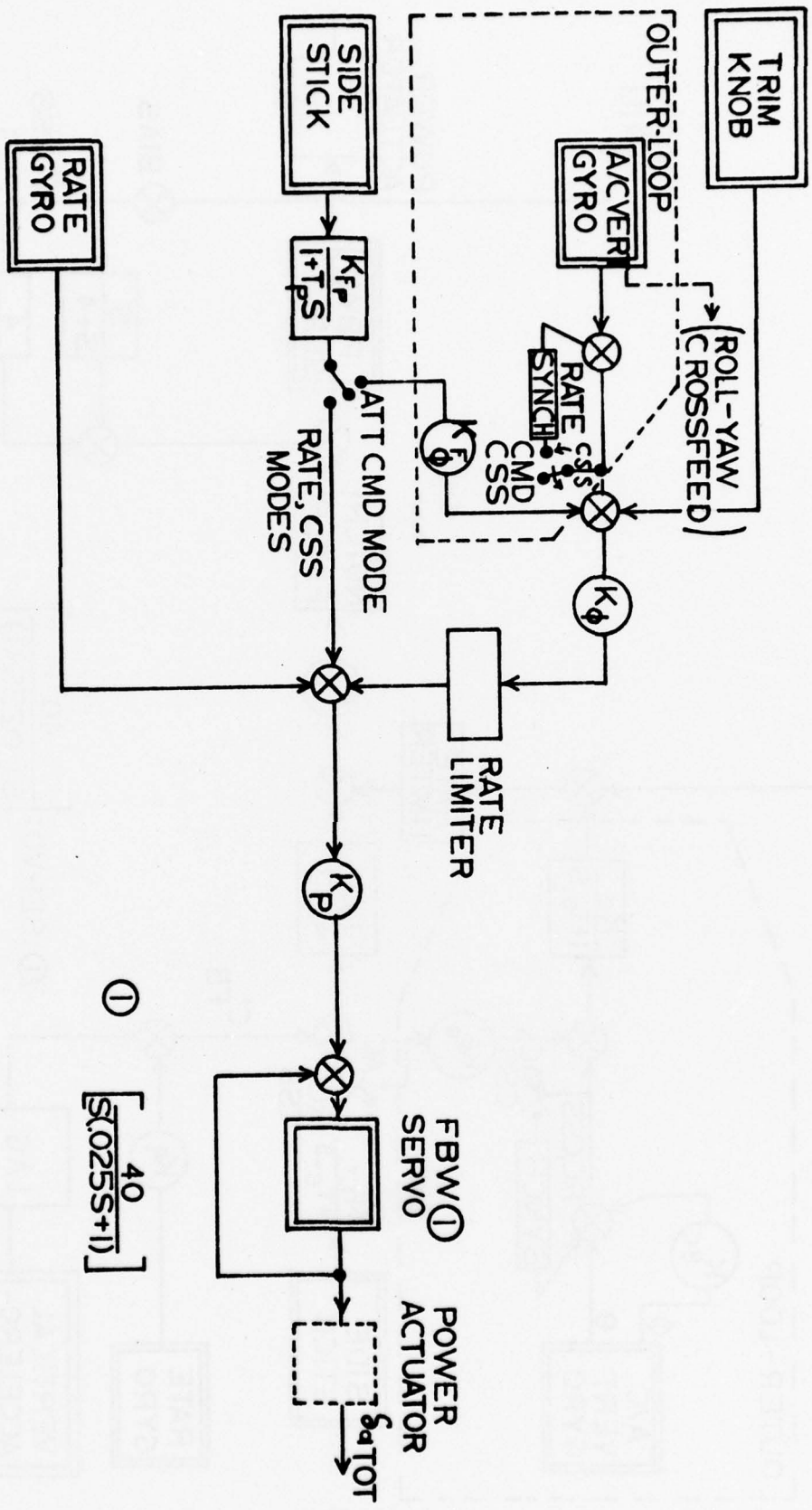

Figure 9. C-141 FBW Roll Axis Analytical Block Diagram

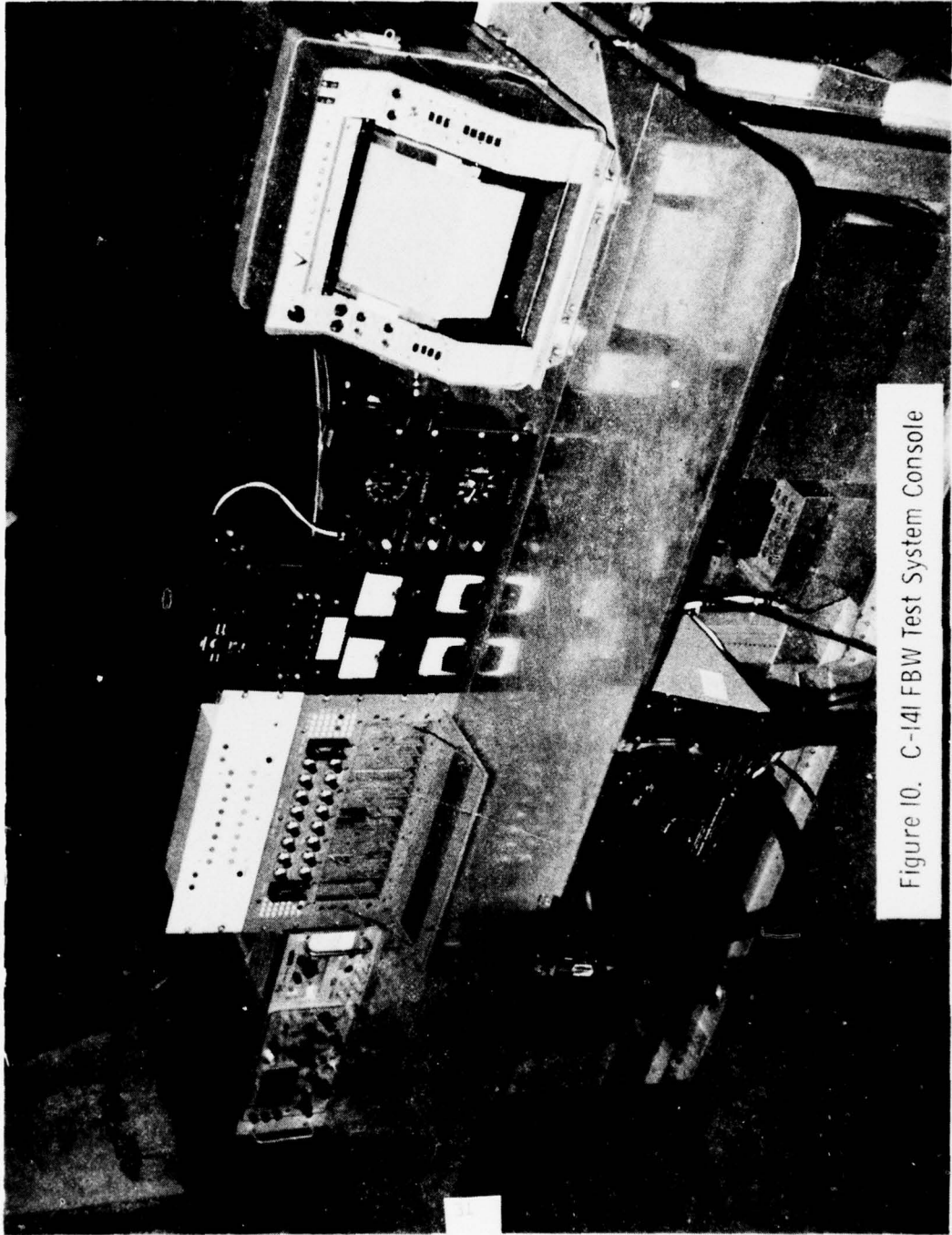

Figure 10. C-141 FBW Test System Console



Figure II. C-141 FBW Rate Gyro Assemblies

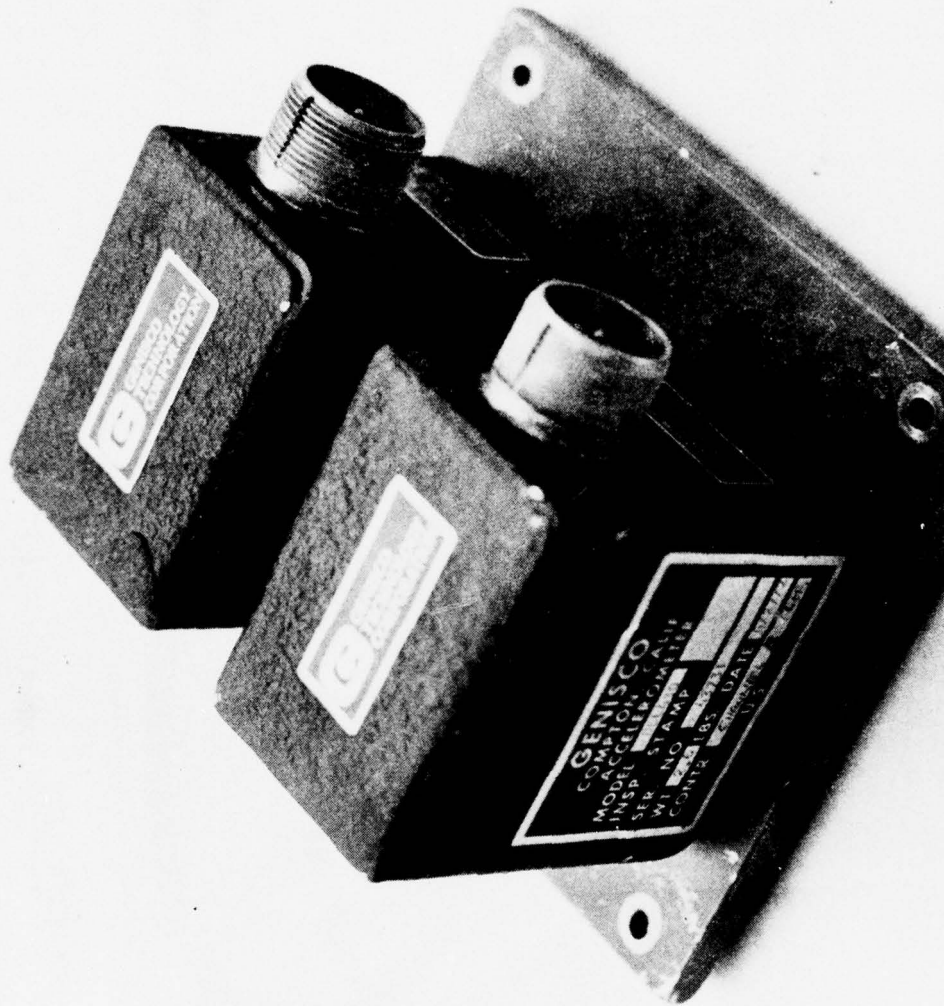

Figure 12. C-141 Vertical Accelerometers

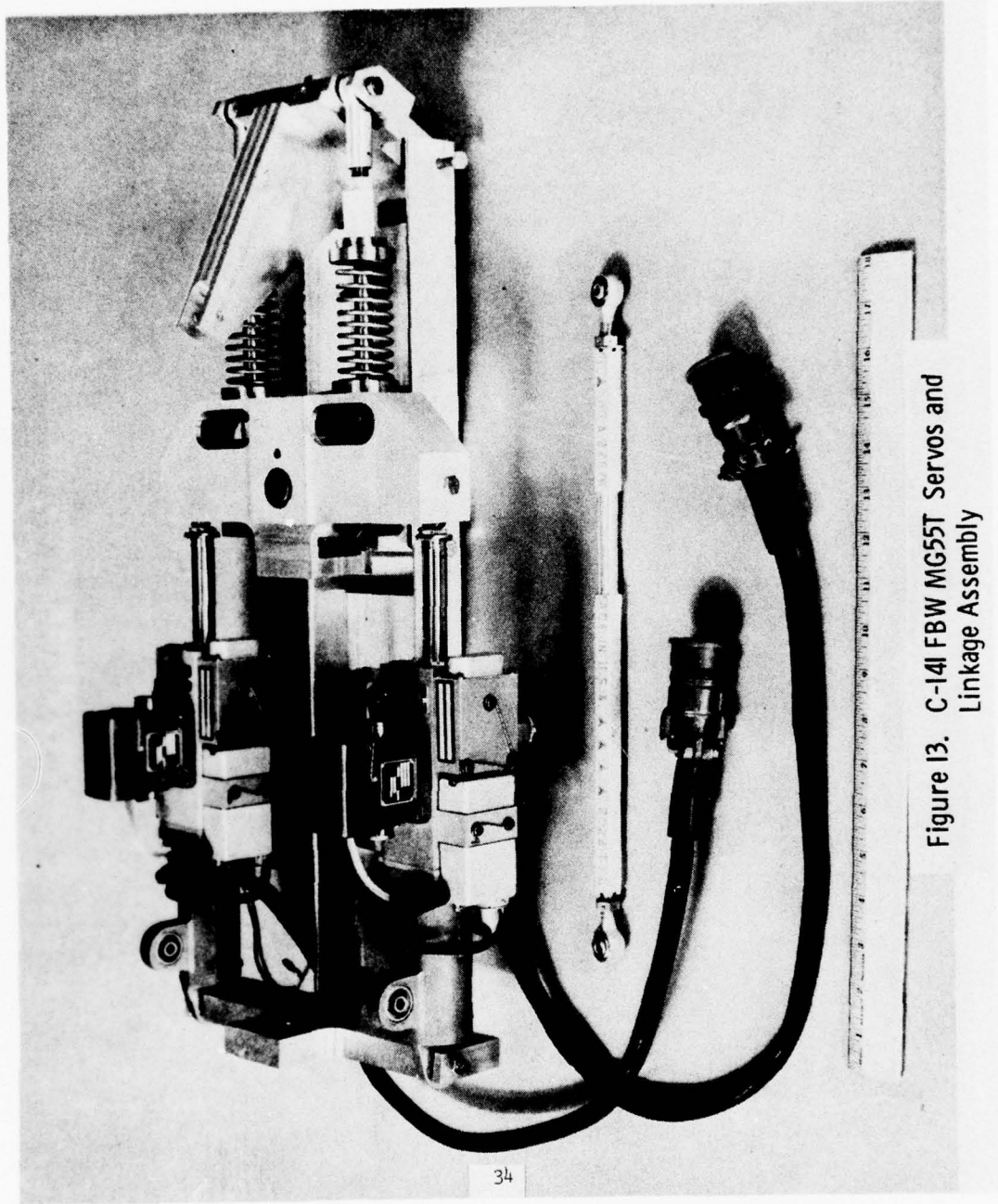

Figure 13. C-141 FBW MG55T Servos and Linkage Assembly

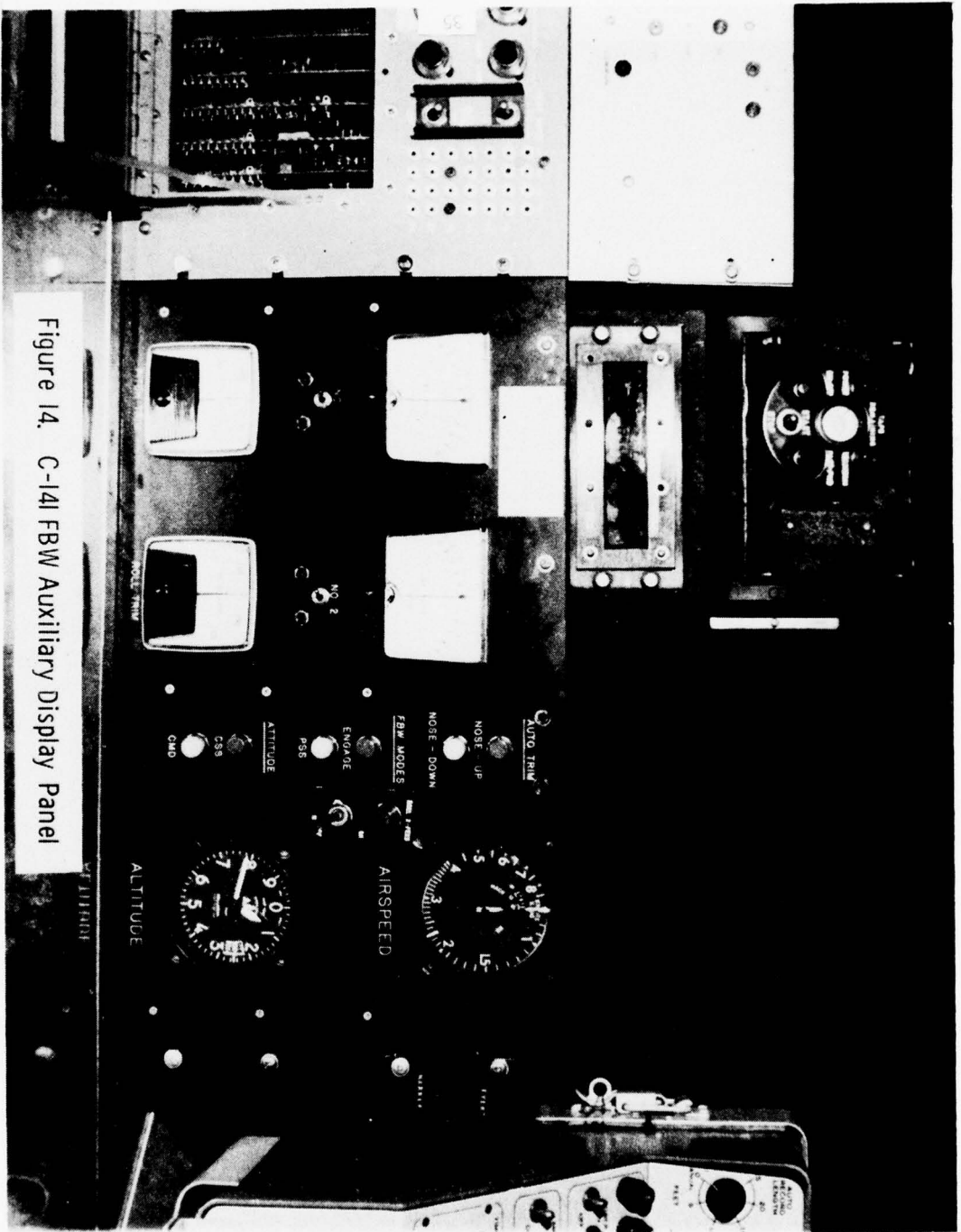

Figure 14. C-141 FBW Auxiliary Display Panel

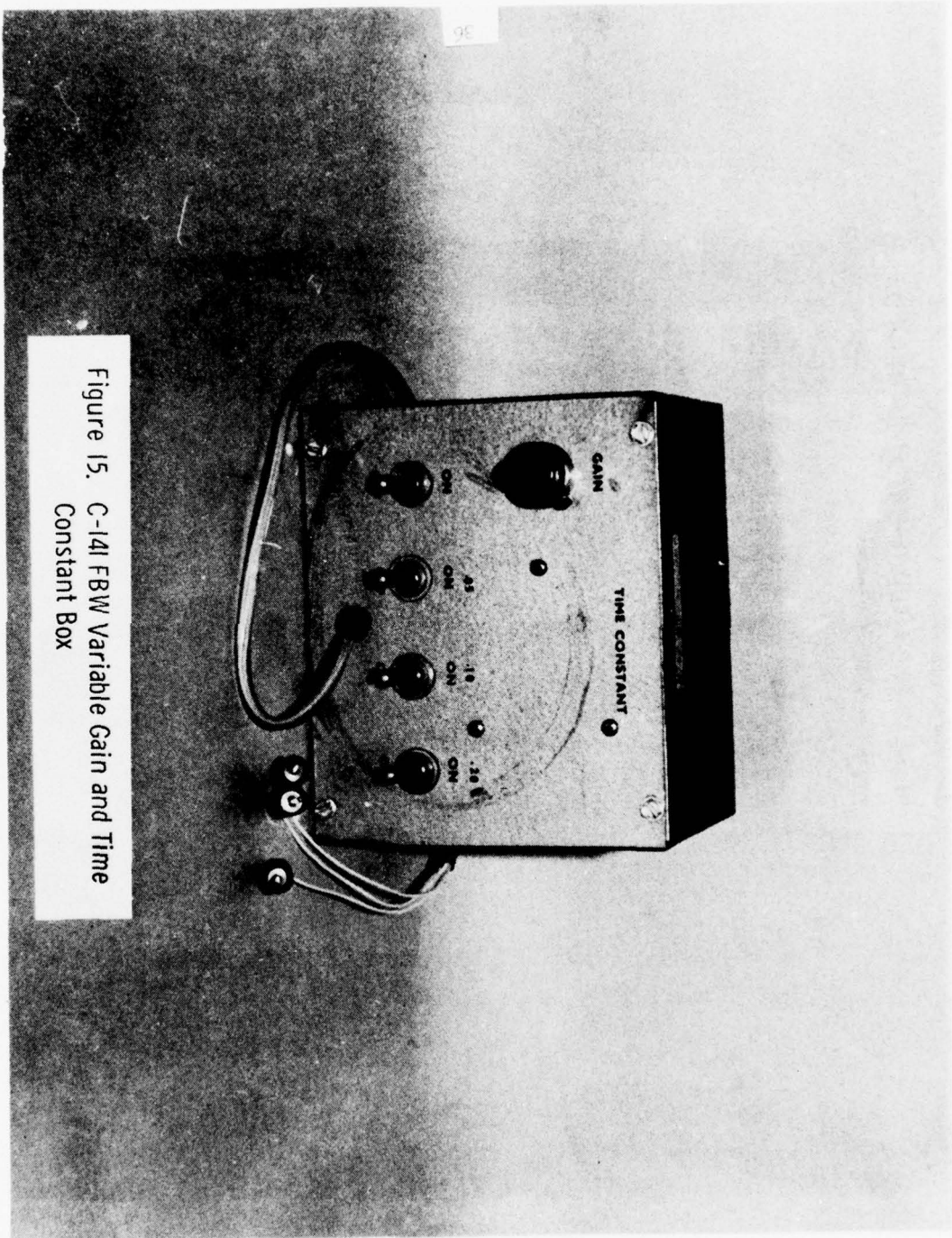

Figure 15. C-141 FBW Variable Gain and Time
Constant Box

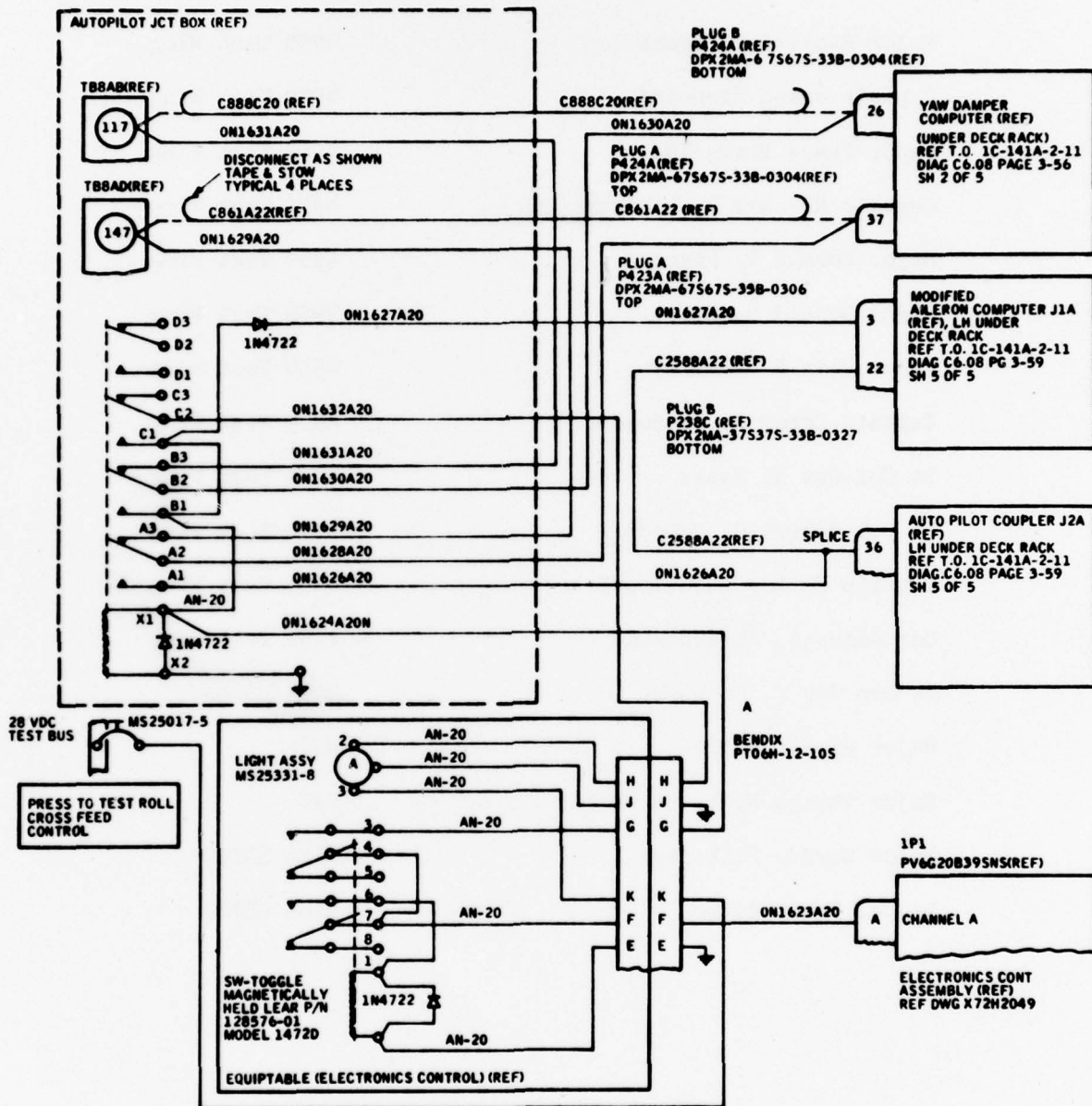

Figure 16. C-141 FBW Roll Crossfeed Wiring Diagram

Major Richard E. Johns	4950 Test Wing
Captain James Richmond	4950 Test Wing
Major James Brenholdt	4950 Test Wing
Captain Michael J. Lipcsey	4950 Test Wing
Major Ronald V. Franzen	4950 Test Wing
Major Donald G. Green	4950 Test Wing
Major Olin H. Bradley	4950 Test Wing
Captain Leroy B. Schroeder	4950 Test Wing
Lt Col Gay E. Jones	4950 Test Wing
Lt Col Robert G. Nabors	4950 Test Wing
Captain Barton B. Switzer	4950 Test Wing
Col James A. Abrahamson	4950 Test Wing
Lt Gen Jay T. Robbins	MAC
Major Gerald Poole	MAC
Major Thomas H. Satterwhite	MAC
Major Gordon Fullerton	NASA LBJSC
Lt Col Karol Bobko	NASA LBJSC

Figure 17. C-141 FBW Evaluation Pilots

- I Takeoff: Conditions GW=210M lbs. fuel 70M lbs.
1. FBW - Engaged
 2. Att OFF
 3. PSS
 4. Auto trim - off
 5. Roll-Yaw crossfeed - ON
 6. Rotation speed = 111KCAS
- II Climbout: Conditions: accelerate to 160KCAS
1. Retract flaps and accelerate to 230KCAS
 2. Autotrim-on after flap retraction (or at call "FLAPS UP")
- Cruise: 9000' and 230 knots -
 Turns and climbs as cleared
- III Maneuvering Conditions 9M' to 15M' 230KCAS ATT OFF
1. Level turns - $\Phi = 20^\circ, 30^\circ, 45^\circ$ Roll out on heading
 2. Climb & descent $\Delta h = 1000'$ $\dot{h} = 1000$ fpm - Repeat as necessary
 3. Climbing turns & descending $\Delta h = 2000'$ $h = 1000$ fpm $\Phi = 30^\circ$
 4. Select CSS and repeat above maneuvers
 5. Select ATT CMD and repeat above maneuvers - Max $\Phi = 30^\circ$
 Demonstrate use of verniers to control Θ & Φ (\dot{h} & $\dot{\Psi}$)
- IIIA Optional - Based on Pilot experience & performance
- Simulated pattern maneuvering 9M' to 15M' 140KCAS
- Flaps-Appch Gear - down
1. Conventional Controls - simulate pattern turns & descent.
 (Non 141 Pilots only)
 2. Trim shot with FBW off.
 3. Engage FBW - Simulate same pattern - ATT OFF
 4. Repeat simulation in CSS

Figure 18. C-141 FBW Standard Mission Profile

IV Descent & Return to Traffic Pattern 230KCAS Descent

1. Option 1 Tacan Appch to ILS
2. Option 2 Vectors to ILS
3. Option 3 Vectors to GCA - runway 05 or 23
Pattern speeds 230 Knots til configure
Slow to 160K on downwind
150K on base
140K to flaps landing on final
130K Final to threshold - Flaps landing
120-110 Touchdown

V Approaches

1. ATT CMD - Low approach
2. ATT OFF
3. CSS
4. Optional approach in mode most interesting to subject pilot

Figure 18. (Contd) C-141 Standard Mission Profile

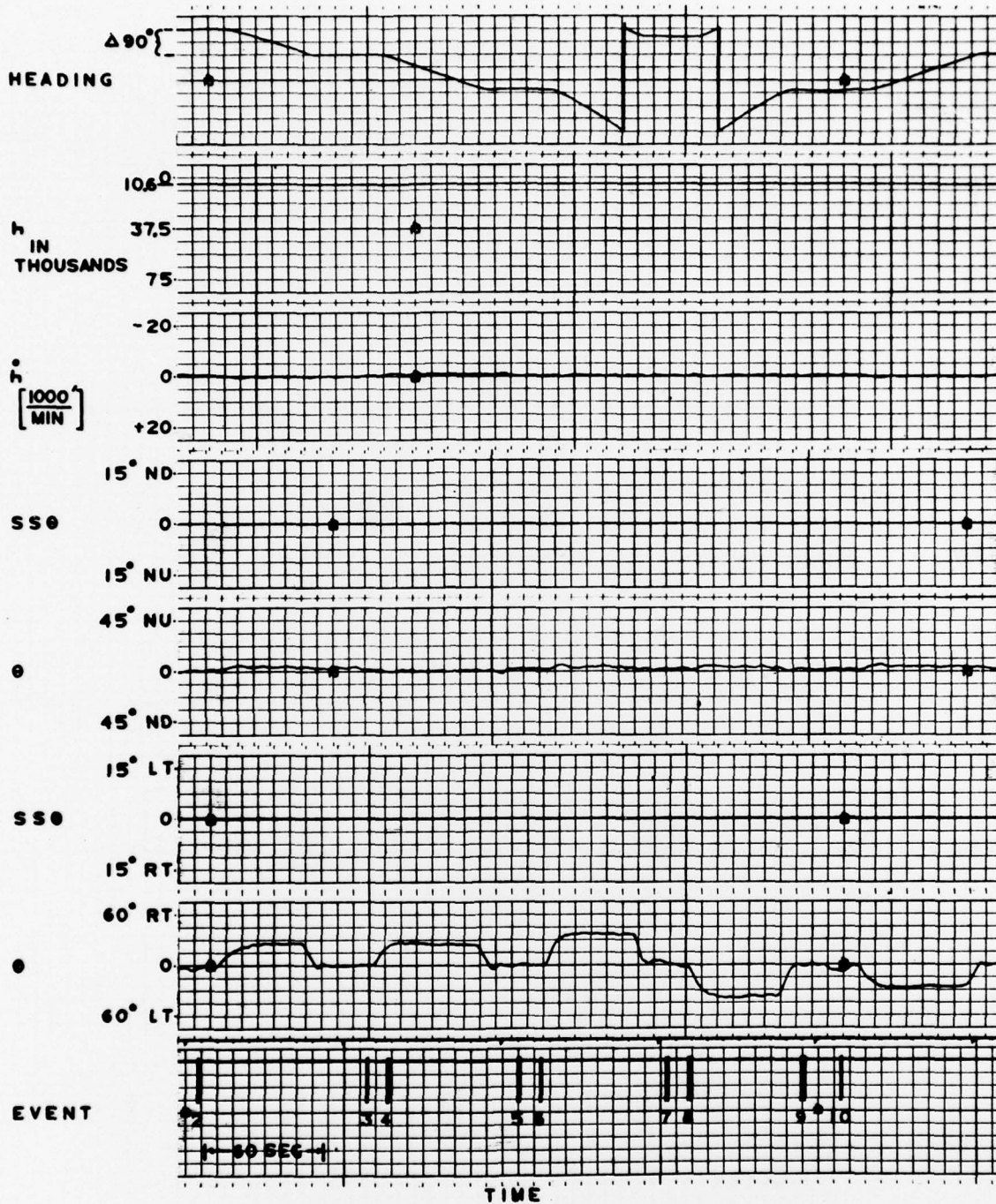

MANUAL MANEUVERS (FBW OFF)
 PROJECT PILOT FLYING
 FLIGHT 16

FIGURE 19
 41

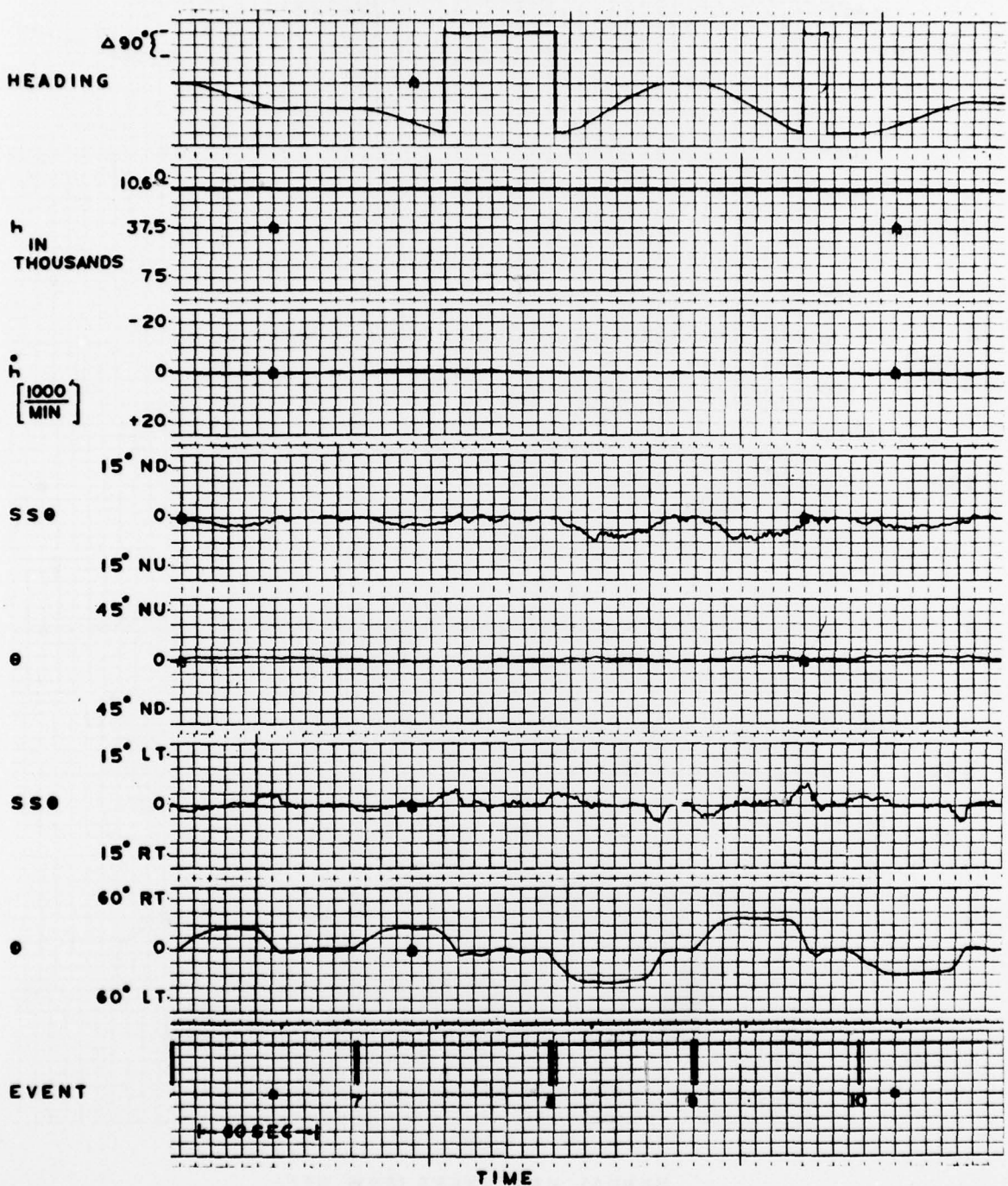

FBW MANEUVERS-ATT OFF
 PROJECT PILOT FLYING
 FLIGHT 16
 FIGURE 20
 42

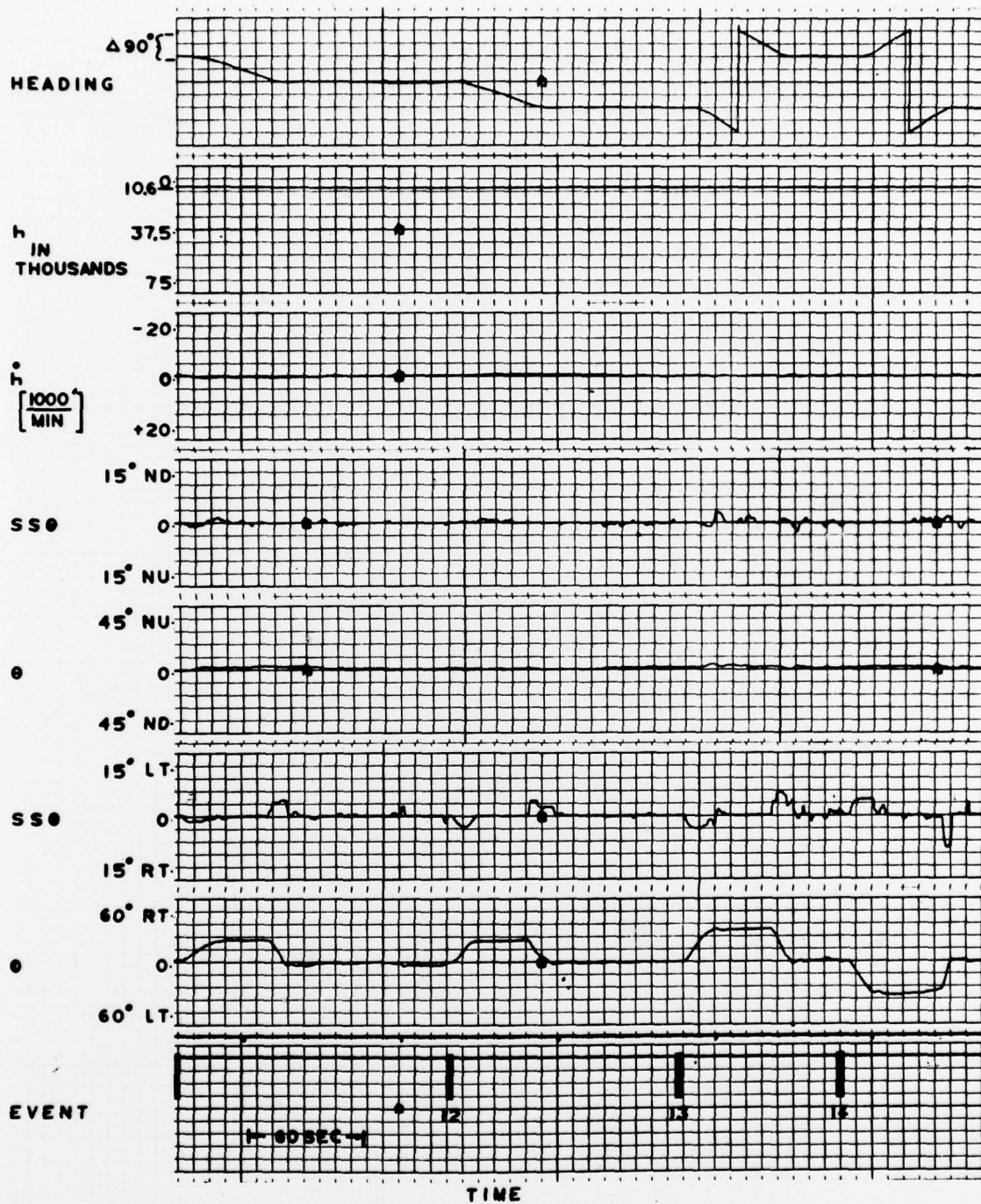

FBW MANEUVERS-ATT CSS
PROJECT PILOT FLYING

FLIGHT 16
FIGURE 21

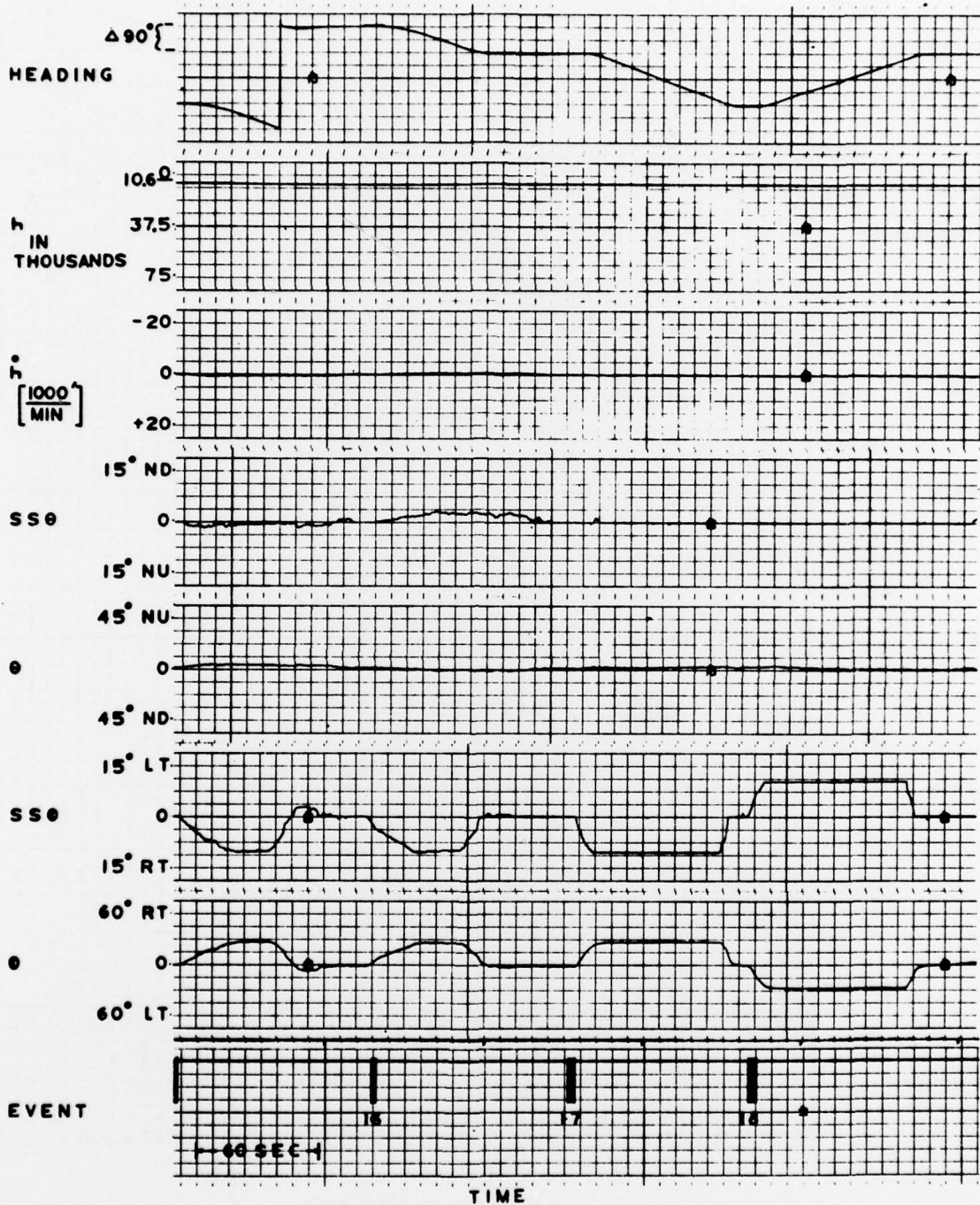

FBW MANEUVERS-ATT CMD
PROJECT PILOT FLYING

FLIGHT 16
FIGURE 22

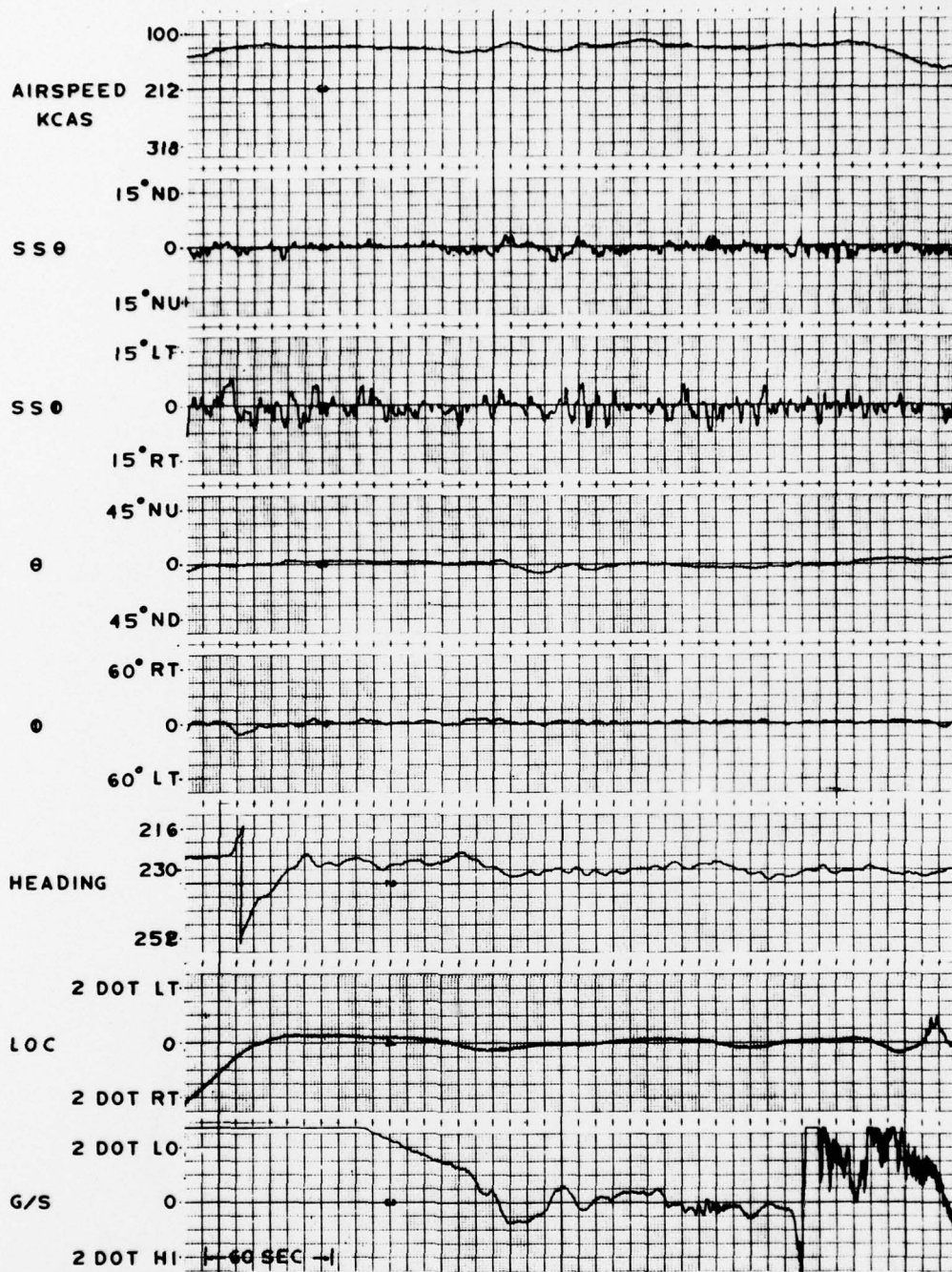

TIME
 RATE COMMAND (ATT OFF) MODE
 APPROACH NO.1 FLIGHT 17

FIGURE 23

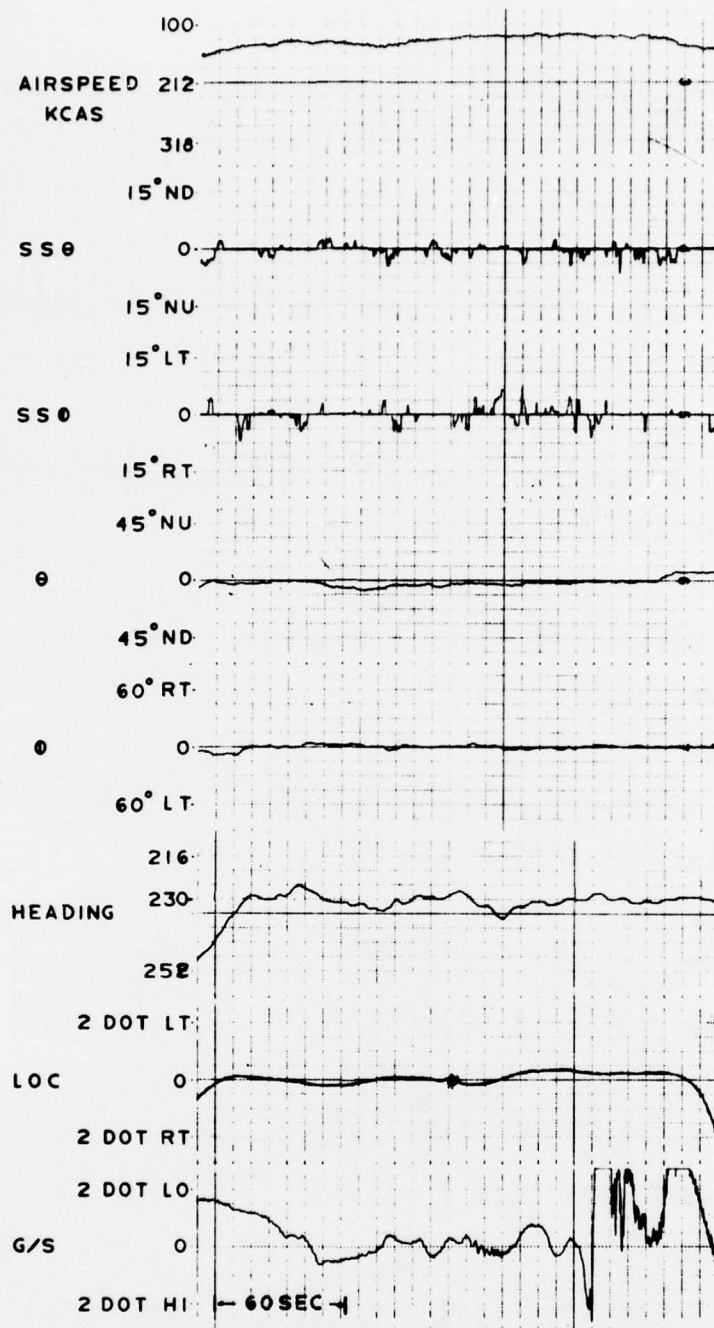

ATTITUDE CONTROL-STICK STEERING
 MODE
 APPROACH NO.2 FLIGHT 17

FIGURE 24

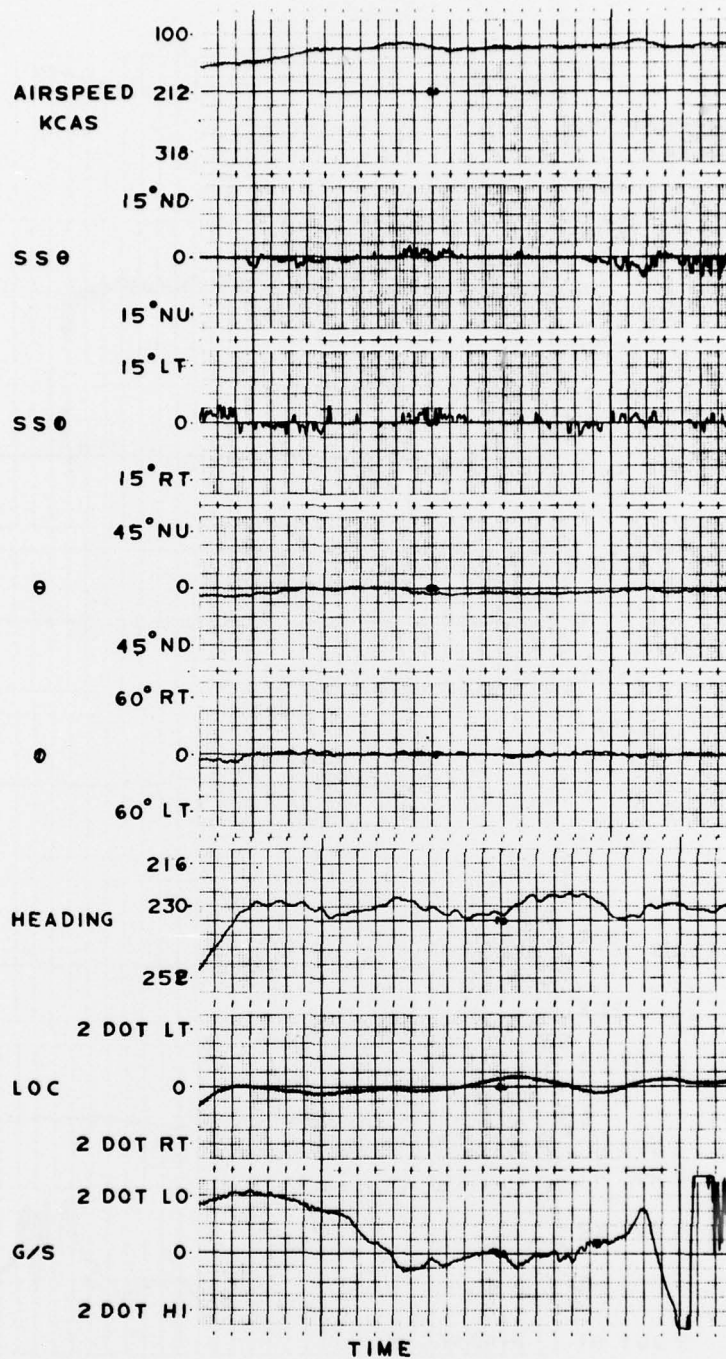

ATTITUDE COMMAND MODE
 APPROACH NO.3 FLIGHT 17

FIGURE 25

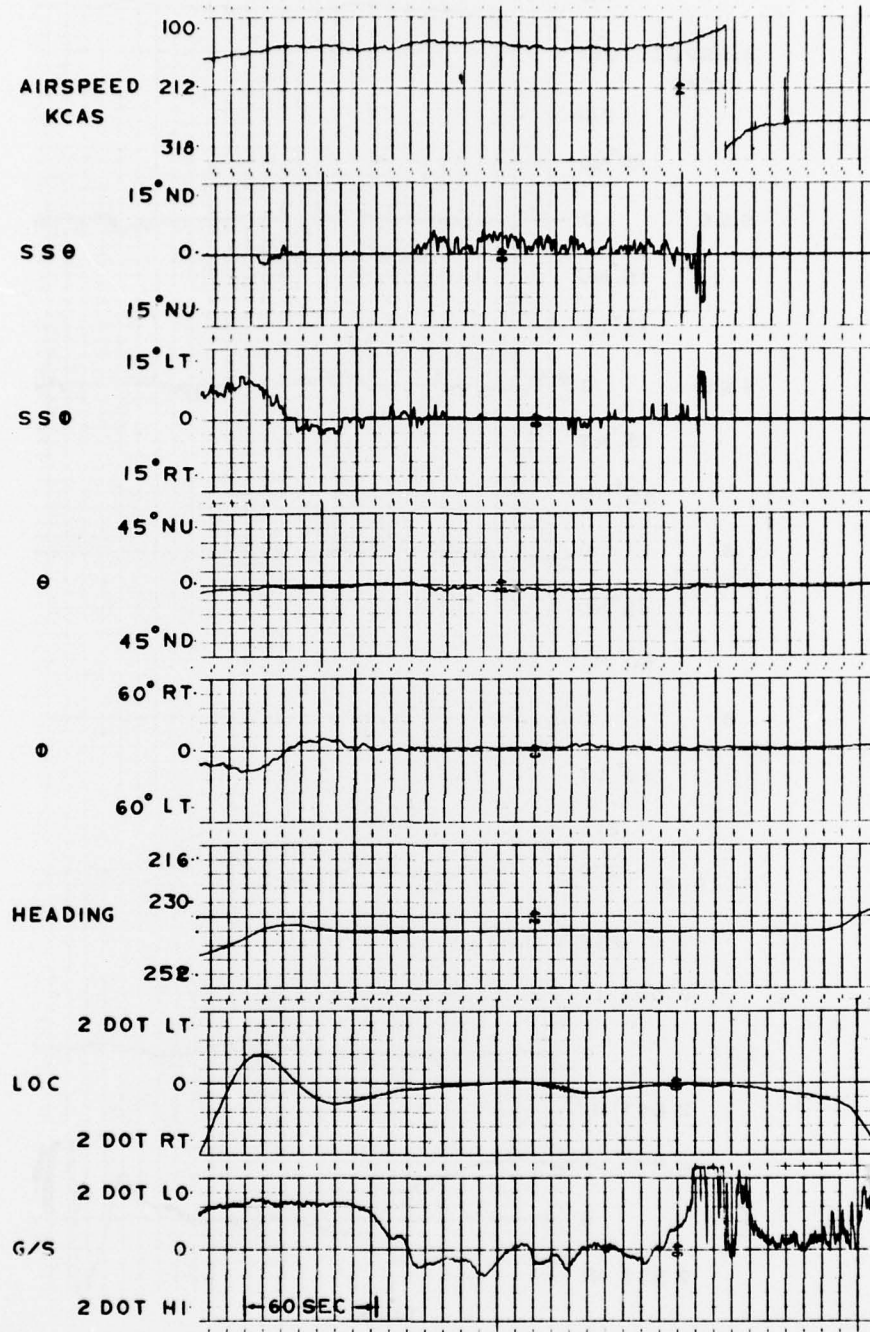

TIME
 ATTITUDE COMMAND MODE
 APPROACH AND LANDING
 FLIGHT 12

FIGURE 26

Table I. C-141 FBW List of Parameters

ITEM	PARAMETER	VCO	TRACK
1	Pitch Angle	1.3	7
2	Pitch Rate	1.7	7
3	Roll Angle	2.3	7
4	Roll Rate	3.0	7
7	Vert. Accel.-Pilot	3.9	7
16	Sidestick Pitch	5.4	7
17	Sidestick Roll	7.35	7
18	Sidestick Pitch Trim	10.5	7
19	Sidestick Roll Trim	1.3	8
20	Pitch Servo Feedbk-A-	1.7	8
21	Roll Servo Feedbk-A-	2.3	8
23	FBW (G) Disengage	3.0	8
22	FBW Engage On/Off	3.9	8
24	FBW Compare Mon. Roll	5.4	8
25	Stab. Trim Nose Up	7.35	8
26	Stab. Trim Nose Dwn	10.5	8
27	FBW Mode Pss/Nss	1.3	9
28	Pitch Sum. Ampl	1.7	9
29	Roll Sum. Ampl	2.3	9
30	Pitch Servo Feedbk -B-	3.0	9
31	Roll Servo Feedbk -B-	3.9	9
32	FBW Compare Mon. Pitch	5.4	9
10	Altitude Rate	7.35	9
12	G/S Steering Sig-CP	10.5	9
13	Loc Steering Sig-CP	1.3	10
14	G/S Deviation ER.-CP	1.7	10
15	LOC Deviation ER.-CP	2.3	10
5	Heading Angle-Cour.	3.9	10
5A	Heading Angle-Fine	5.4	10
49	C Star Blend	7.35	10
33	Elevator Pos.	1.3	1
35	Rudder Pos.	1.7	1
34	Aileron Pos.	2.3	1
41	Pitch Angle Aux.	3.0	1
42	Roll Angle Aux	3.9	1
43	YAW Angle	5.4	1
36	Stabilizer Pos.	10.5	1

Table I (Contd) C-14I FBW List of Parameters

ITEM	PARAMETER	VCO	TRACK
44	Pitch Rate Aux	3.9	3
45	Roll Rate Aux	5.4	3
6	YAW Rate	7.35	3
8	Vertical Accel -CG-	2.3	5
11	Airspeed-Course	3.0	5
9	Altitude-Course	3.9	5
38	Event Mark	5.4	5
11A	Airspeed-Fine	7.35	5
9A	Altitude-Fine	10.5	5
40	Reference OSC.	12.5	2
39	Time Code	-	12

POT	PITCH POT SETTINGS										ROLL POT SETTINGS					
	STICK RATE K _{Fc+}	STICK ATT. K _{Fθ}	STICK T _{C+}	ATT. K _θ	C star K _{C+}	ATT. T _{θL}	RATE K _θ	BANK COMP K _{BC}	STICK RATE K _{FP}	STICK ATT. K _{Fθ}	STICK T _P	ATT. K _θ	RATE K _P	BIAS See		
KCAS																
140 KCAS PARADROP	400 + 270	860	050	250 + 160	500 + 330	460	250	850	250 + 220	700	045	400	650 + 430	700/800		
200 KCAS INITIAL TEST	575 + 390	860	050	600 + 400	350 + 235	1000	250	800	550 + 360	700	045	400	550 + 360	700/800		
220 KCAS	575 + 390	860	050	500 + 330	275 + 180	1000	250	800	525 + 350	650	045	400	450 + 300	700/800		
260 KCAS MED ALT CRUISE	600 + 400	860	050	400 + 270	225 + 150	1000	250	784	500 + 330	600	045	400	350 + 240	630		
300 KCAS	600 + 400	860	050	400 + 270	200 + 135	1000	250	784	500 + 330	600	045	400	350 + 240	480		

+2/3 Gains used initially to familiarize pilots with FBW

Table 2. C-141 FBW Parameter Settings

Table 3. C-141 FBW Cooper Harper Rating

PILOT	UP AND AWAY MANEUVERING				APPROACHES AND LANDINGS			
	MANUAL CONTROL	FBW MODES			MANUAL CONTROL	FBW MODES		
		RATE COMMAND	ATTITUDE COMMAND	CSS		RATE COMMAND	ATTITUDE COMMAND	CSS
A	-	-	-	-	-	-	-	-
B	A3	A2	A3	A2.5	A3	A2	A2	A2
C	-	A3	A6**	A2	-	A3	A2	A3
D	-	A3	A2	A2	-	A2	A1/A5*	A1
E	-	A2	A4.5	A3	-	-	-	-
F	A3.5	A3	A2	A2	A4	A1	A1	A1
G	-	A2	A2	A3	-	A2	A2	A3
H	A2	A1	A2	A1	-	-	-	-
I	A3	A3	A3	A2	-	-	-	-
J	A4	A2	A5	A2	-	-	-	-
K	A4	A3	A3	A2	-	-	-	-
L	-	A1	A2	A1	-	A1	A1	A2
M	A3	A3	A5	A3	-	-	-	-

*Flare and landing

**In roll axis

Table 4. C-141 FBW Pilot Experience

PILOT	TOTAL HOURS	C-141 HOURS	MAJOR EXPERIENCE		COMBAT TOUR TYPE / HOURS	ARPS GRADUATE	REMARKS
			TYPE	APPROX. HOURS			
A*	6000	2500	C-135	2000	EC-47 900	YES	C-5 Autoland C-141 Awls, BS Phys.
B	5200	1550	C-135	1900	OV-10 900	YES	Graduate, USAFA
C	4700	0	KC-135	1200	F-4 500	YES	BS, Aero. Engr.
D	4000	3000	N/A		C-7A 750	YES	C-141 Awls BS. Aero. Engr.
E	5700	500	KC-135	2000	C-130 700	YES	MS. Engr. Mgt. BS. Aero. Engr.
F	5000	500	KC-135	-	AC-47 900	YES	MS. Aero. Engr.
G	3950	-	F-101 F-102	-	None	YES	BS. Engr.
H	2750	0	B-52	900	C-130 1100	YES	MBA. in Eng. Mgmt.
I	3300	2400	N/A		C-47 700	NO	
J	7000	3000	C-124	2000	None	NO	BS. Mech. Engr.
K	6500	200	B-47	-	B-57 700	YES	Extensive flight test experience.
L	8700	0	Various Transp.		HC-130 1000	YES	
M	5400	120	C-135	3500	O-1, 1000 O-2	YES	BS. Chem. Engr.

*Project Pilot

Table 5. C-141 FBW Mode Preference

PILOT	UP AND AWAY MANUVERING		APPROACH AND LANDING	
	BEST	WORST	BEST	WORST
A	CSS	AC	CSS	AC
B	RC	AC	Equally preferred	
C	CSS	AC	AC	RC, CSS
D	AC, CSS	RC	CSS, AC ¹	RC
E	RC	AC	CSS/RC ²	AC
F	AC, CSS	RC	Equally preferred	
G	RC, AC	CSS	RC, AC	CSS
H	RC, CSS	AC	No rating	
I	CSS	RC, AC	No rating	
J	RC, CSS	AC	No rating ³	
K	CSS	RC, AC	CSS	No rating
L	RC, CSS	AC	RC, AC	CSS
M	RC, CSS	AC	No approaches	

	CSS	RC	AC
BEST	10	7	3
WORST	1	4	10

	CSS	RC	AC
BEST	4	3	3
WORST	3	2	2

1
Except for flare

2
Verbal comment, no rating assigned - preferred CSS in pattern RC on final

3
Verbal comment