

AD A O 47070

12  
B.S.

AD

# PRODUCTION ENGINEERING EFFORT ON M42/M46 GRENADE BODIES

## Final Report

by

H. Tereshkow

15 November 1977

DDC  
RECEIVED  
NOV 21 1977  
RESERVED  
F

DRDAR-LCU-DS

U.S. Army Armament Research and Development Center

Dover, New Jersey 07801



**AVCO**  
SYSTEMS DIVISION

201 LOWELL STREET, WILMINGTON, MA. 01887

Contract DAAK10-77-C-0055

DISTRIBUTION OF THIS DOCUMENT IS UNLIMITED.

THE FINDINGS IN THIS REPORT ARE NOT TO BE CONSTRUED AS AN  
OFFICIAL DEPARTMENT OF THE ARMY POSITION.

DESTROY THIS REPORT WHEN NO LONGER NEEDED. DO NOT RETURN  
IT TO THE ORIGINATOR.

AS NO. \_\_\_\_\_  
DDC FILE COPY

PRODUCTION ENGINEERING EFFORT  
ON M42/M46 GRENADE BODIES

FINAL REPORT

by

H. Tereshkow

15 November 1977

DRDAR-LCU-DS  
U. S. Army Armament Research and Development Center  
Dover, New Jersey 07801

Avco Systems Division  
201 Lowell Street  
Wilmington MA 01887

Contract DAAK10-77-C-0055

Distribution of this document is unlimited.

The findings in this report are not to be construed as an  
official Department of the Army position.

Destroy this report when no longer needed. Do not return  
it to the originator.

<b>REPORT DOCUMENTATION PAGE</b>		<b>READ INSTRUCTIONS BEFORE COMPLETING FORM</b>	
1. REPORT NUMBER AVSD-0318-77-RR ✓		2. GOVT ACCESSION NO.	3. RECIPIENT'S CATALOG NUMBER
4. TITLE (and Subtitle) PRODUCTION ENGINEERING EFFORT ON M42/M46 GRENADE BODIES		5. TYPE OF REPORT & PERIOD COVERED Final Report - 25 Apr 77 <del>thru 15 Nov 77</del>	
6. AUTHOR(s) H. Tereshkow		7. PERFORMING ORG. REPORT NUMBER	
9. PERFORMING ORGANIZATION NAME AND ADDRESS Avco Systems Division Wilmington MA 01887		8. CONTRACT OR GRANT NUMBER(s) DAAK10-77-C-0055	
11. CONTROLLING OFFICE NAME AND ADDRESS U.S. Army Armament Research and Development Center; Dover NJ 07801 DRDAR-LCU-DS		10. PROGRAM ELEMENT, PROJECT, TASK AREA & WORK UNIT NUMBERS	
14. MONITORING AGENCY NAME & ADDRESS (if different from Controlling Office) 1293p.		12. REPORT DATE 15 November 1977	
		13. NUMBER OF PAGES	
		15. SECURITY CLASS. (of this report) Unclassified	
		15a. DECLASSIFICATION/DOWNGRADING SCHEDULE	
16. DISTRIBUTION STATEMENT (of this Report) Distribution of this report is unlimited.			
17. DISTRIBUTION STATEMENT (of the abstract entered in Block 20, if different from Report) Distribution of this report is unlimited.			
18. SUPPLEMENTARY NOTES			
19. KEY WORDS (Continue on reverse side if necessary and identify by block number)  This final report			
20. ABSTRACT (Continue on reverse side if necessary and identify by block number) This the final report of Contract DAAK10-77-C-0055 during the period 25 April 1977 through 15 November 1977. It contains the findings and conclusions resulting from an effort to determine alternate methods for producing the M42/M46 Grenade Body. The prime purpose of this study was to establish a manufacturing process which would result in lower cost grenade bodies. ←			

404788i

Handwritten initials/signature

Summary

The Avco candidate M42/M46 grenade body design, evolving from this production engineering effort, is a two piece unit comprised of a cylindrical body and formed cap joined by a high energy laser welding machine.

The body is fabricated from seamless 4140 tubing machined to its required external and internal dimensions. Embossing of the M42 body is accomplished by using an internal knurling tool.

Caps are to be embossed, blanked and formed, pierced and trimmed to size in a transfer press.

It is estimated that roughly .1382 pounds of scrap will be generated in the production of each grenade body by this proposed manufacturing process.

Recurring costs to produce M42/M46 grenade bodies at a rate of 1,400,000 a month on a 3-8-5 basis is estimated to be 76 cents.

ACCESSION for	
N°15	White Section <input checked="" type="checkbox"/>
DDC	B.f.f Section <input type="checkbox"/>
RESEARCH	<input type="checkbox"/>
DISTRIBUTION	
EV	
DISTRIBUTION/AVAILABILITY OFFICE	
SPECIAL	
A	

## Table of Contents

Section		Page
	Report Documentation Page (DD Form 1473)	i
	Summary	ii
	Table of Contents	iii
	List of Illustrations	fv
	List of Tables	vi
I	Contract Requirements	1
II	Applicable Drawings and Specifications	3
III	Technical Discussion - Developmental Program	10
IV	Production Process - Proposed	38
V	Scrap Analysis	73
VI	Cost Analysis	75
	Addendum 1 - Product Assurance Operation Sheets	76
	Addendum 2 - Internal Knurling Tool	85
VII	Distribution	86

List of Illustrations

Figure		Page
1	Body Assembly - Type PH	4
2	Body Assembly - Type CA	5
3	Body - Type PH	6
4	Body - Type CA	7
5	Cap	8
6	Stud	9
7	Avco Two-Piece Grenade Body	11
8	Internal Knurling Tool	13
9	Laser Welding Machine	14
10	M42/M46 Loading Cases	19
11	Normalized Loading - Case III	21
12	Regions Used for "SAMS"	22
13	Cap Increments	24
14	Case I - Axial Stresses vs. Arc Length	27
15	Case II - Axial Stresses vs. Arc Length	28
16	Case IV - Axial Stresses vs. Arc Length	29
17	Case III - Axial Stresses vs. Arc Length	30
18	Case III - Axial Stresses vs. Arc Length	31

List of Illustrations

(continued)

Figure		Page
19	Case III - Hoop Stresses vs. Arc Length	32
20	Case III - Hoop Stresses vs. Arc Length	33
21	M42/M46 Grenade Production Flow Chart	39

List of Tables

Table		Page
1	Body Membrane Stresses	25
2	Body Bending Stresses	26
3	Deformations at Welded Joint	36
4	Production Equipment	70
5	Product Assurance Equipment	72

## SECTION I

### CONTRACT REQUIREMENTS

The scope of work to be accomplished under this contract follows:

A. Objectives

Establishment of production engineering processes which will result in a lower cost M42/M46 grenade body.

B. Procedure

The contractor shall within a 6-month period perform the following:

1. Conduct production engineering studies utilizing various manufacturing procedures and processes to produce the M42/M46 grenade body.
2. Preparation of a manufacturing process flow describing each piece of equipment planned for use in production.
3. An estimate of the amount of scrap generated, as a function of material in the body, shall be estimated.
4. Data and procedures which can be used in establishing the fact that the proposed method of fabrication will result in piece parts which are physically and functionally interchangeable with those produced by the current process.
5. Manufacture a quantity of grenade bodies to develop the candidate process and deliver one hundred each M42 and M46 grenade bodies to the procuring agency.
6. Preparation of detailed drawings depicting the selected design.
7. Preparation of the final report.

C. Schedule

	Task	Months to Completion after Contract Award
1.	Complete initial review of design and determine candidate design.	1
2.	Complete process development.	5
3.	Deliver test bodies.	6
4.	Deliver drawings, data, and final report.	6

## SECTION II

### APPLICABLE DRAWINGS AND SPECIFICATIONS

- A. The following drawings were used as guides in support of this effort:

9215344	Body, Type PH
9215374	Body, Type CA
9215345	Stud

- B. The recommended design evolving from this program shall conform to the requirements of the following specifications, which were used as guides:

MIL-G-48047(PA)	Grenade, GP: M46 Body Assembly, Type CA, for
MIL-G-50546(PA)	Grenade, GP: M42 Body Assembly, Type PH, for

- C. The following drawings define the grenade body designs resulting from this program:

9326631	Body Assembly, Type CA
9326630	Body Assembly, Type PH
9326627	Cap
9326629	Body, Type CA
9326628	Body, Type PH
9215345	Stud



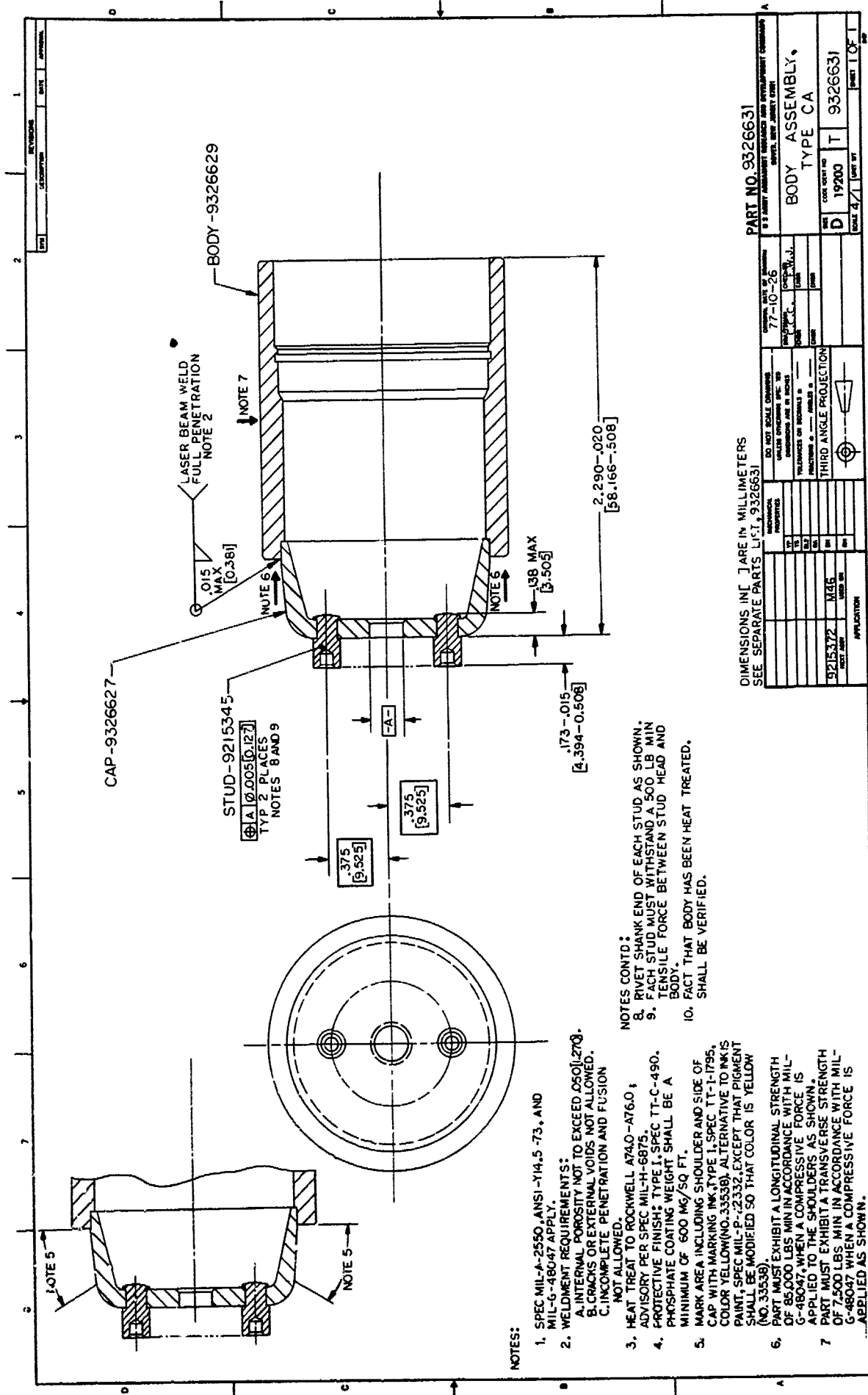

DIMENSIONS IN [ ] ARE IN MILLIMETERS  
SEE SEPARATE PARTS LIST, 9326631

REV	DATE	BY	APP	DESCRIPTION
D	19200	T		9326631
PART NO. 9326631				
BODY ASSEMBLY, TYPE CA				
PART 1 OF 1				

- NOTES:
- SPEC MIL-A-2550, ANSI-Y14.5-73, AND MIL-G-48047 APPLY.
  - WELDMENT REQUIREMENTS:
    - INTERNAL POROSITY NOT TO EXCEED .050(.270).
    - CRACKS OR EXTERNAL VOIDS NOT ALLOWED.
    - INCOMPLETE PENETRATION AND FUSION NOT ALLOWED.
  - HEAT TREAT TO ROCKWELL A74.0-A76.0 ± ADVISORY PER SPEC MIL-H-6875.
  - PROTECTIVE FINISH: TYPE I, SPEC TT-C-490. PHOSPHATE COATING WEIGHT SHALL BE A MINIMUM OF 600 MG/SQ FT.
  - MARK AREA INCLUDING SHOULDER AND SIDE OF CAP WITH MARKING INK TYPE I, SPEC TT-1-1795, COLOR YELLOW(NO.33538). ALTERNATIVE TO INK IS PAINT, SPEC MIL-P-22332, EXCEPT THAT PIGMENT SHALL BE MODIFIED SO THAT COLOR IS YELLOW (NO.33539).
  - PART MUST EXHIBIT A LONGITUDINAL STRENGTH OF 85,000 LBS MIN IN ACCORDANCE WITH MIL-G-48047, WHEN A COMPRESSIVE FORCE IS APPLIED TO THE SHOULDERS AS SHOWN.
  - PART MUST EXHIBIT A TRANSVERSE STRENGTH OF 7,500 LBS MIN IN ACCORDANCE WITH MIL-G-48047 WHEN A COMPRESSIVE FORCE IS APPLIED AS SHOWN.

- NOTES CONTD:
- RIVET SHANK END OF EACH STUD AS SHOWN.
  - EACH STUD MUST WITHSTAND A 500 LB MIN TENSILE FORCE BETWEEN STUD HEAD AND BODY.
  - FACT THAT BODY HAS BEEN HEAT TREATED, SHALL BE VERIFIED.

FIGURE 2







REV	DESCRIPTION	DATE	BY	CHK
A	EOPA-40-011 31-3-67	11-31-67		
B	E22PA-7000656-1	5-20-70		CM
C	NOR-7E01256-1	11-15-72		

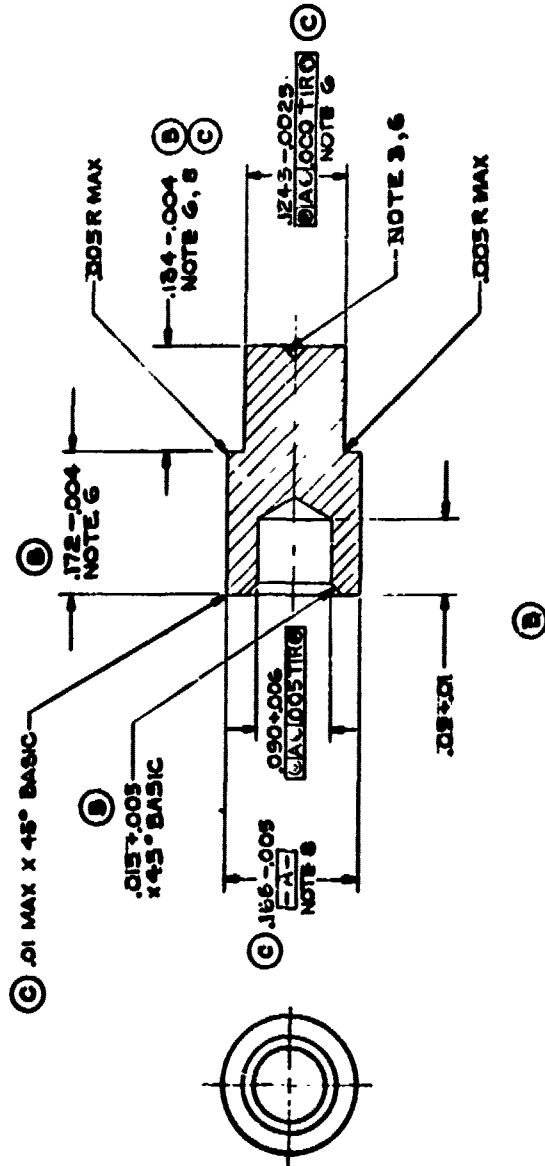

- NOTES:**
- 1- SPEC MIL-A-2550 APPLIES.
  - 2- MATERIAL: STEEL BAR, CORROSION RESISTING, CONDITION LIGHTLY OR ASTM A 276.
  - 3- SLIGHT INDENTATION PERMISSIBLE.
  - 4- FINISH ALL OVER .125 OF MIL-STD-171.
  - 5- PROTECTIVE FINISH: FINISH NO. 5.4.1
  - 6- NOTED DIMENSIONS ARE ADVISORY PROVIDED MANDATORY REQUIREMENTS OF DWGS D9215343 OR D9215373 ARE ADHERED TO.
  - 7 - ALTERNATIVE MATERIAL: STEEL, WIRE, CORROSION RESISTING, AISI TYPE 490, FOR COLD HEADING, CONDITION LIGHTLY DRAFTER, SPEC ASTM-A 499.
  - 8 - WHEN STUD IS COLD HEADED, .124-.004 DIMENSION SHALL BE .144-.004, ADVISORY. LARGER OUTER DIAMETER SHALL NOT EXCEED .164.

PART NO. 9215345

UNLESS OTHERWISE SPECIFIED DIMENSIONS ARE IN INCHES		DATE OF CHANGE	14 JUN 1966
TOLERANCES ON DECIMALS		DATE	14 JUN 1966
FRACTIONS		BY	
MATERIAL		CHKD	
HEAT TREATMENT		APP'D	
FINISH		DATE	
APPLY PART NO.		SIZE	C 19203
PART NO.		DESCRIPTION	STUD
DRAWN		SCALE	1:1
CHECKED		DATE	
APPROVED		BY	
MATERIAL		DATE	
HEAT TREATMENT		DATE	
FINISH		DATE	
APPLY PART NO.		DATE	
PART NO.		DESCRIPTION	STUD
DRAWN		SCALE	1:1
CHECKED		DATE	
APPROVED		BY	
MATERIAL		DATE	
HEAT TREATMENT		DATE	
FINISH		DATE	
APPLY PART NO.		DATE	
PART NO.		DESCRIPTION	STUD
DRAWN		SCALE	1:1
CHECKED		DATE	
APPROVED		BY	
MATERIAL		DATE	
HEAT TREATMENT		DATE	
FINISH		DATE	
APPLY PART NO.		DATE	
PART NO.		DESCRIPTION	STUD
DRAWN		SCALE	1:1
CHECKED		DATE	
APPROVED		BY	
MATERIAL		DATE	
HEAT TREATMENT		DATE	
FINISH		DATE	
APPLY PART NO.		DATE	
PART NO.		DESCRIPTION	STUD
DRAWN		SCALE	1:1
CHECKED		DATE	
APPROVED		BY	
MATERIAL		DATE	
HEAT TREATMENT		DATE	
FINISH		DATE	
APPLY PART NO.		DATE	
PART NO.		DESCRIPTION	STUD
DRAWN		SCALE	1:1
CHECKED		DATE	
APPROVED		BY	
MATERIAL		DATE	
HEAT TREATMENT		DATE	
FINISH		DATE	
APPLY PART NO.		DATE	
PART NO.		DESCRIPTION	STUD
DRAWN		SCALE	1:1
CHECKED		DATE	
APPROVED		BY	
MATERIAL		DATE	
HEAT TREATMENT		DATE	
FINISH		DATE	
APPLY PART NO.		DATE	
PART NO.		DESCRIPTION	STUD
DRAWN		SCALE	1:1
CHECKED		DATE	
APPROVED		BY	
MATERIAL		DATE	
HEAT TREATMENT		DATE	
FINISH		DATE	
APPLY PART NO.		DATE	
PART NO.		DESCRIPTION	STUD
DRAWN		SCALE	1:1
CHECKED		DATE	
APPROVED		BY	
MATERIAL		DATE	
HEAT TREATMENT		DATE	
FINISH		DATE	
APPLY PART NO.		DATE	
PART NO.		DESCRIPTION	STUD
DRAWN		SCALE	1:1
CHECKED		DATE	
APPROVED		BY	
MATERIAL		DATE	
HEAT TREATMENT		DATE	
FINISH		DATE	
APPLY PART NO.		DATE	
PART NO.		DESCRIPTION	STUD
DRAWN		SCALE	1:1
CHECKED		DATE	
APPROVED		BY	
MATERIAL		DATE	
HEAT TREATMENT		DATE	
FINISH		DATE	
APPLY PART NO.		DATE	
PART NO.		DESCRIPTION	STUD
DRAWN		SCALE	1:1
CHECKED		DATE	
APPROVED		BY	
MATERIAL		DATE	
HEAT TREATMENT		DATE	
FINISH		DATE	
APPLY PART NO.		DATE	
PART NO.		DESCRIPTION	STUD
DRAWN		SCALE	1:1
CHECKED		DATE	
APPROVED		BY	
MATERIAL		DATE	
HEAT TREATMENT		DATE	
FINISH		DATE	
APPLY PART NO.		DATE	
PART NO.		DESCRIPTION	STUD
DRAWN		SCALE	1:1
CHECKED		DATE	
APPROVED		BY	
MATERIAL		DATE	
HEAT TREATMENT		DATE	
FINISH		DATE	
APPLY PART NO.		DATE	
PART NO.		DESCRIPTION	STUD
DRAWN		SCALE	1:1
CHECKED		DATE	
APPROVED		BY	
MATERIAL		DATE	
HEAT TREATMENT		DATE	
FINISH		DATE	
APPLY PART NO.		DATE	
PART NO.		DESCRIPTION	STUD
DRAWN		SCALE	1:1
CHECKED		DATE	
APPROVED		BY	
MATERIAL		DATE	
HEAT TREATMENT		DATE	
FINISH		DATE	
APPLY PART NO.		DATE	
PART NO.		DESCRIPTION	STUD
DRAWN		SCALE	1:1
CHECKED		DATE	
APPROVED		BY	
MATERIAL		DATE	
HEAT TREATMENT		DATE	
FINISH		DATE	
APPLY PART NO.		DATE	
PART NO.		DESCRIPTION	STUD
DRAWN		SCALE	1:1
CHECKED		DATE	
APPROVED		BY	
MATERIAL		DATE	
HEAT TREATMENT		DATE	
FINISH		DATE	
APPLY PART NO.		DATE	
PART NO.		DESCRIPTION	STUD
DRAWN		SCALE	1:1
CHECKED		DATE	
APPROVED		BY	
MATERIAL		DATE	
HEAT TREATMENT		DATE	
FINISH		DATE	
APPLY PART NO.		DATE	
PART NO.		DESCRIPTION	STUD
DRAWN		SCALE	1:1
CHECKED		DATE	
APPROVED		BY	
MATERIAL		DATE	
HEAT TREATMENT		DATE	
FINISH		DATE	
APPLY PART NO.		DATE	
PART NO.		DESCRIPTION	STUD
DRAWN		SCALE	1:1
CHECKED		DATE	
APPROVED		BY	
MATERIAL		DATE	
HEAT TREATMENT		DATE	
FINISH		DATE	
APPLY PART NO.		DATE	
PART NO.		DESCRIPTION	STUD
DRAWN		SCALE	1:1
CHECKED		DATE	
APPROVED		BY	
MATERIAL		DATE	
HEAT TREATMENT		DATE	
FINISH		DATE	
APPLY PART NO.		DATE	
PART NO.		DESCRIPTION	STUD
DRAWN		SCALE	1:1
CHECKED		DATE	
APPROVED		BY	
MATERIAL		DATE	
HEAT TREATMENT		DATE	
FINISH		DATE	
APPLY PART NO.		DATE	
PART NO.		DESCRIPTION	STUD
DRAWN		SCALE	1:1
CHECKED		DATE	
APPROVED		BY	
MATERIAL		DATE	
HEAT TREATMENT		DATE	
FINISH		DATE	
APPLY PART NO.		DATE	
PART NO.		DESCRIPTION	STUD
DRAWN		SCALE	1:1
CHECKED		DATE	
APPROVED		BY	
MATERIAL		DATE	
HEAT TREATMENT		DATE	
FINISH		DATE	
APPLY PART NO.		DATE	
PART NO.		DESCRIPTION	STUD
DRAWN		SCALE	1:1
CHECKED		DATE	
APPROVED		BY	
MATERIAL		DATE	
HEAT TREATMENT		DATE	
FINISH		DATE	
APPLY PART NO.		DATE	
PART NO.		DESCRIPTION	STUD
DRAWN		SCALE	1:1
CHECKED		DATE	
APPROVED		BY	
MATERIAL		DATE	
HEAT TREATMENT		DATE	
FINISH		DATE	
APPLY PART NO.		DATE	
PART NO.		DESCRIPTION	STUD
DRAWN		SCALE	1:1
CHECKED		DATE	
APPROVED		BY	
MATERIAL		DATE	
HEAT TREATMENT		DATE	
FINISH		DATE	
APPLY PART NO.		DATE	
PART NO.		DESCRIPTION	STUD
DRAWN		SCALE	1:1
CHECKED		DATE	
APPROVED		BY	
MATERIAL		DATE	
HEAT TREATMENT		DATE	
FINISH		DATE	
APPLY PART NO.		DATE	
PART NO.		DESCRIPTION	STUD
DRAWN		SCALE	1:1
CHECKED		DATE	
APPROVED		BY	
MATERIAL		DATE	
HEAT TREATMENT		DATE	
FINISH		DATE	
APPLY PART NO.		DATE	
PART NO.		DESCRIPTION	STUD
DRAWN		SCALE	1:1
CHECKED		DATE	
APPROVED		BY	
MATERIAL		DATE	
HEAT TREATMENT		DATE	
FINISH		DATE	
APPLY PART NO.		DATE	
PART NO.		DESCRIPTION	STUD
DRAWN		SCALE	1:1
CHECKED		DATE	
APPROVED		BY	
MATERIAL		DATE	
HEAT TREATMENT		DATE	
FINISH		DATE	
APPLY PART NO.		DATE	
PART NO.		DESCRIPTION	STUD
DRAWN		SCALE	1:1
CHECKED		DATE	
APPROVED		BY	
MATERIAL		DATE	
HEAT TREATMENT		DATE	
FINISH		DATE	
APPLY PART NO.		DATE	
PART NO.		DESCRIPTION	STUD
DRAWN		SCALE	1:1
CHECKED		DATE	
APPROVED		BY	
MATERIAL		DATE	
HEAT TREATMENT		DATE	
FINISH		DATE	
APPLY PART NO.		DATE	
PART NO.		DESCRIPTION	STUD
DRAWN		SCALE	1:1
CHECKED		DATE	
APPROVED		BY	
MATERIAL		DATE	
HEAT TREATMENT		DATE	
FINISH		DATE	
APPLY PART NO.		DATE	
PART NO.		DESCRIPTION	STUD
DRAWN		SCALE	1:1
CHECKED		DATE	
APPROVED		BY	
MATERIAL		DATE	
HEAT TREATMENT		DATE	
FINISH		DATE	
APPLY PART NO.		DATE	
PART NO.		DESCRIPTION	STUD
DRAWN		SCALE	1:1
CHECKED		DATE	
APPROVED		BY	
MATERIAL		DATE	
HEAT TREATMENT		DATE	
FINISH		DATE	
APPLY PART NO.		DATE	
PART NO.		DESCRIPTION	STUD
DRAWN		SCALE	1:1
CHECKED		DATE	
APPROVED		BY	
MATERIAL		DATE	
HEAT TREATMENT		DATE	
FINISH		DATE	
APPLY PART NO.		DATE	
PART NO.		DESCRIPTION	STUD
DRAWN		SCALE	1:1
CHECKED		DATE	
APPROVED		BY	
MATERIAL		DATE	
HEAT TREATMENT		DATE	
FINISH		DATE	
APPLY PART NO.		DATE	
PART NO.		DESCRIPTION	STUD
DRAWN		SCALE	1:1
CHECKED		DATE	
APPROVED		BY	
MATERIAL		DATE	
HEAT TREATMENT		DATE	
FINISH		DATE	
APPLY PART NO.		DATE	
PART NO.		DESCRIPTION	STUD
DRAWN		SCALE	1:1
CHECKED		DATE	
APPROVED		BY	
MATERIAL		DATE	
HEAT TREATMENT		DATE	
FINISH		DATE	
APPLY PART NO.		DATE	
PART NO.		DESCRIPTION	STUD
DRAWN		SCALE	1:1
CHECKED		DATE	
APPROVED		BY	
MATERIAL		DATE	
HEAT TREATMENT		DATE	
FINISH		DATE	
APPLY PART NO.		DATE	
PART NO.		DESCRIPTION	STUD
DRAWN		SCALE	1:1
CHECKED		DATE	
APPROVED		BY	
MATERIAL		DATE	
HEAT TREATMENT		DATE	
FINISH		DATE	
APPLY PART NO.		DATE	
PART NO.		DESCRIPTION	STUD
DRAWN		SCALE	1:1
CHECKED		DATE	
APPROVED		BY	
MATERIAL		DATE	
HEAT TREATMENT		DATE	
FINISH		DATE	
APPLY PART NO.		DATE	
PART NO.		DESCRIPTION	STUD
DRAWN		SCALE	1:1
CHECKED		DATE	
APPROVED		BY	
MATERIAL			

## SECTION III

### TECHNICAL DISCUSSION DEVELOPMENTAL PROGRAM

#### Introduction

This program is a six-month production engineering effort aimed at determining a more economical manufacturing process for producing M42/M46 grenade bodies.

The manufacturing process currently employed uses as its fundamental a deep drawn cup from an embossed steel sheet. Annealing cycles are interspersed to facilitate working the material. The drawing process is subsequently followed by machining, heat treating, and inspection procedures. Large amounts of scrap are generated in the body blanking process.

Avco has investigated numerous manufacturing processes for possible use in fabricating the M42/M46 grenade body. Based on previous experience with this assembly, it has been concluded that a two-piece design is a viable approach for affecting economies in its production.

The geometry of the grenade body lends itself to be broken down into a cylindrical body and a cap, which can be joined at the shoulder.

The initial portion of this discussion will address the techniques utilized in producing the developmental hardware in support of this production study effort. Subsequent sections will focus on a proposed production plan.

#### A. Developmental Hardware

Having established a reference configuration, a two-piece assembly-- Figure 7, the primary engineering emphasis was placed upon arriving at a joint design which could be readily machined and subsequently joined in a reliable and economical manner. Details of the joint are shown in Drawings 9326630 (Figure 1) and 9326631 (Figure 2).

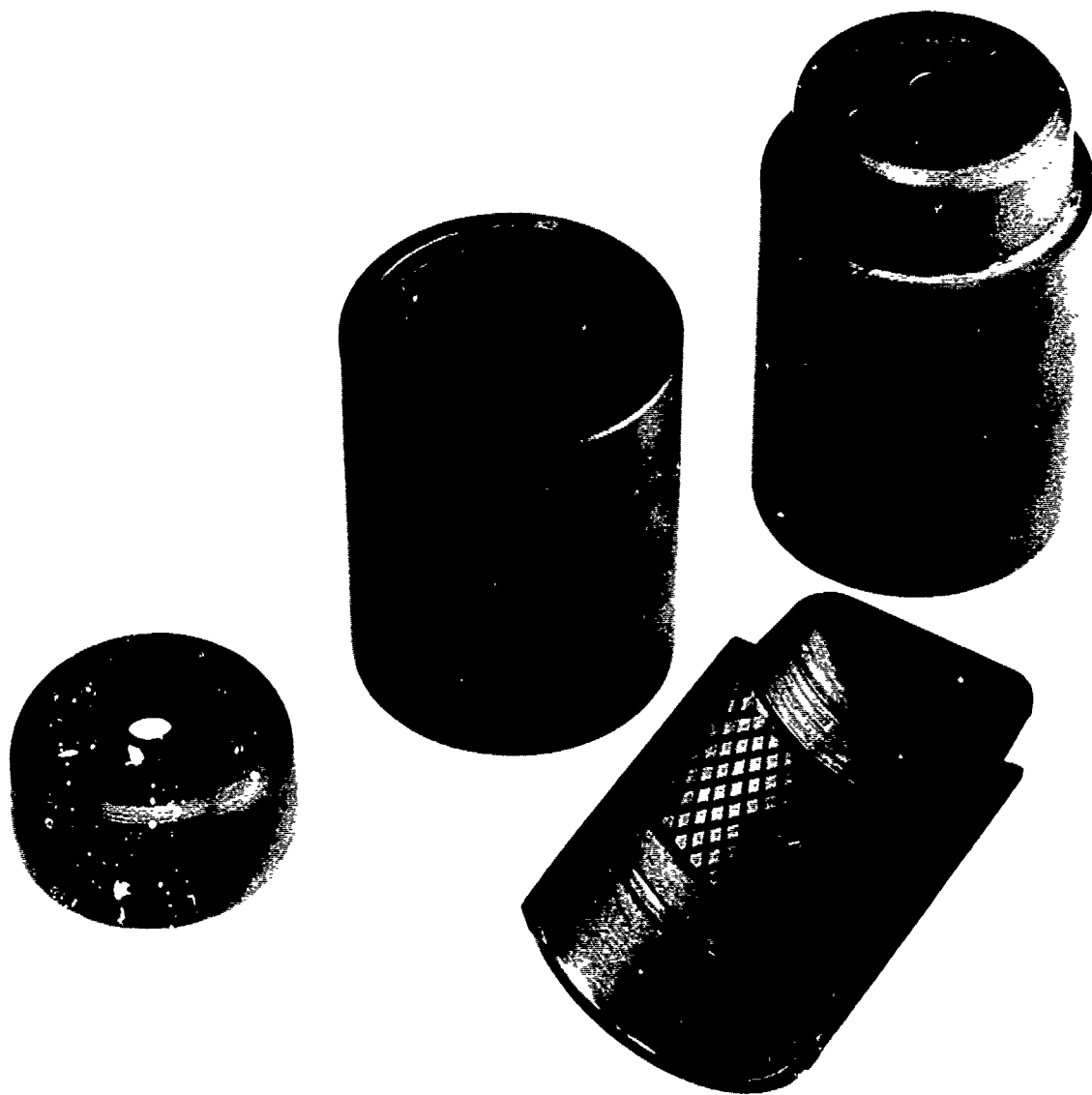

FIGURE 7 AVCO TWO-PIECE GRENADE BODY

At the same time it was decided to use the Avco Everett Research Laboratory laser for welding the cap to the body. Other methods for joining were reviewed and will be addressed later in this report.

Seamless 4140 alloy steel tubing was selected as material for the grenade body. Lengths of tubing were fed into the headstock of a chucker where the outer and inner diameters were machined. A portion of the inner surface was knurled to produce an embossed pattern. The internal knurling tool is shown in Figure 8. A pitch of .088 inches was selected as it would produce particles of the order of 2 grains. Following the knurling operation, the inner surface was machined to remove the pyramidal peaks resulting from the knurling. The end was then faced off and a counterbore operation required to provide a seat for the cap was accomplished. The body was then cut off to length, and the process repeated for succeeding parts. Next the pieces were placed into a turret lathe for completing the machining at the grenade open end.

It was planned to make a stamped piece from which the cap could be machined to finished dimensions. However, problems were encountered in trying to obtain the proper configuration in the equipment and tooling available. At this point it was decided to machine the cap from 4140 alloy steel bar stock in order to maintain schedule.

This decision in no way appeared to compromise the design concept as the joint configuration and material remained unchanged.

Avco has elected to omit embossing the M42 cap from this study. It is felt to emboss flat stock in a rolling mill is a well established process and that all effort should be centered on the cap-to-body joint and embossing the body.

Numerous samples were machined and laser welded. Samples were sectioned to verify full weld penetration. A fixture (Figure 9) was designed and fabricated which positioned and rotated the piece parts in the laser welding machine. Power levels and rotating speed were established using representative piece parts.

After completion of the laser welding operation, all the welded assemblies were grit blasted internally to clean the weld flash, the sharp edges and burrs remaining from the knurling. Cleaning of the residue dust was accomplished by hand washing. Heat treating was completed and certified by the vendor, as required by drawing and specification. A 100 percent hardness check was made in house, followed by a certified protective zinc phosphate coating. The studs were installed and the M46 configuration painted as required. The completed parts were given a final inspection and packaged for shipment.

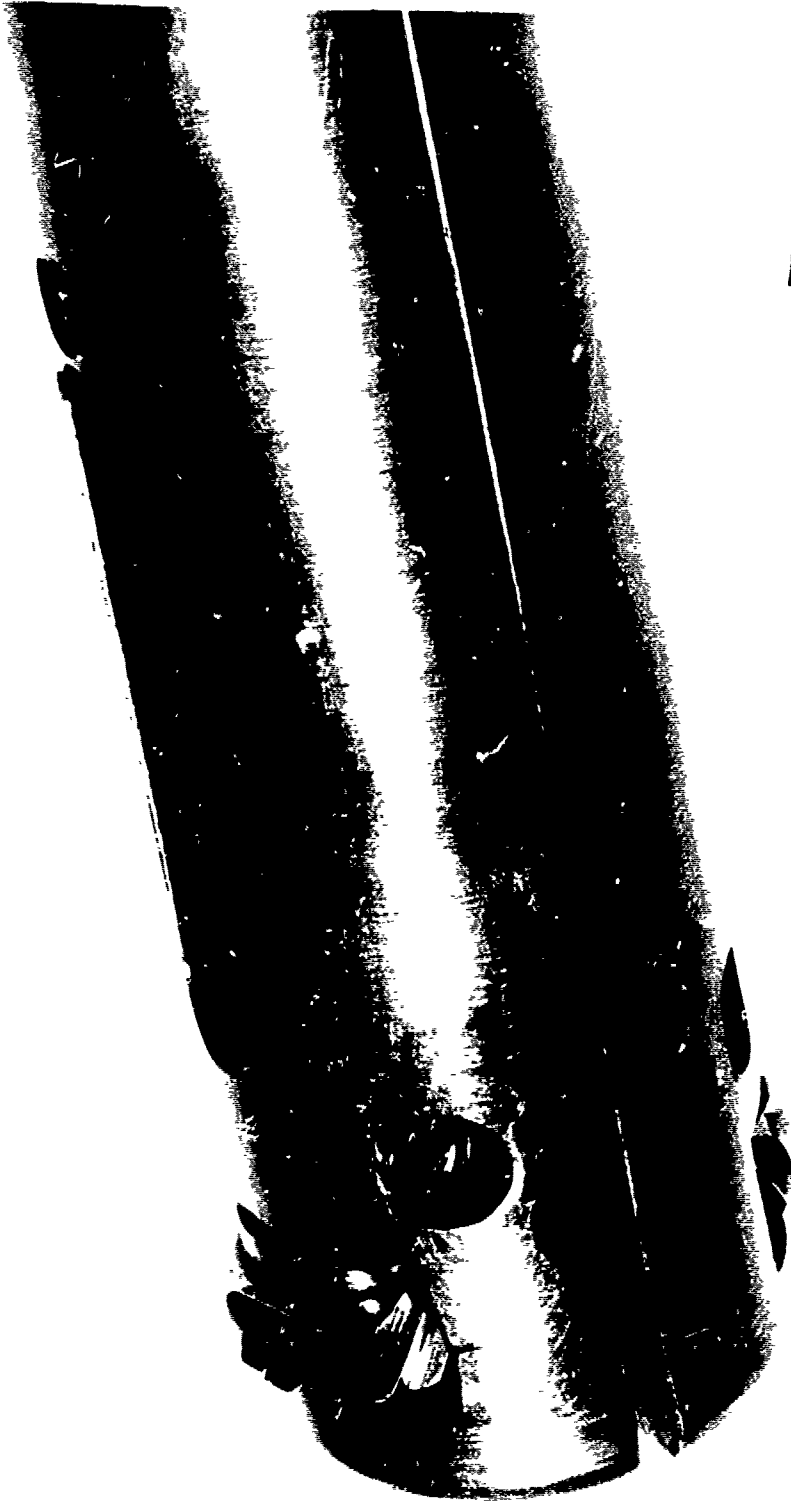

FIGURE 8 INTERNAL KNURLING TOOL



FIGURE 9 LASER WELDING MACHINE

## B. Product Assurance

Avco Product Assurance has been involved in all phases of the M42/M46 Development Program. The following will serve as an outline of major efforts and results of inspections and tests conducted by Product Assurance.

1. Product Assurance Engineering was involved in the initial design review with particular attention being given to the feasibility of laser welding and the inherent problems of qualifying the weld.
2. Preparation of inspection and test instructions (Product Assurance Operation Sheets) for receiving, in-process and final inspections, as well as non-destructive tests. (See Addendum 1.)
3. Performed receiving inspection on all purchased items.
4. Conducted in-process inspections during machining phases of all detail parts.
5. Performed preliminary tests on sample welded assemblies in order to develop acceptance criteria. The samples tested were chosen due to high degrees of external porosity and were considered "worst case." These assemblies were radiographically inspected and showed high degrees of internal porosity, with individual pores measuring from .015 - .065. Additional samples with smooth, continuous welds and exhibiting no external porosity were chosen for test comparison. Radiographic inspection revealed some internal porosity but considerably less than previous tests. Individual pores measured .015-.040. A push test was conducted on each test assembly using Tinius Olsen test equipment to determine weld strength. Parts were placed in a fixture resting on the outer shoulder. A 1-inch diameter rod was inserted into the body assembly against the inside surface of the cap. In all cases, failure was in the parent metal with no visible damage to the weld.
6. Performed 100 percent radiographic inspection on welded assemblies in the following manner: Parts were set up resting on the largest outside diameter with the machine head tilted 15 degrees. This was done to prevent the near side of the weld from being superimposed on the back. In order to see the entire weld area, it was necessary to take two shots--90 degrees apart--of each assembly. Results of the radiography are as follows:
  - a. All assemblies exhibited 100% weld penetration.

b. Thirty-four percent (34%) of total assemblies contained some porosity measuring .015 - .045.

c. Of the total assemblies 0.8 percent contained single pores measuring .050.

d. Of the total assemblies 65.2 percent contained negligible porosity based on preliminary test results outlined in this report.

7. Performed hardness tests on each assembly with the following results:

9326630 (EX24131)

Rockwell A71-A73

9326631 (EX23869)

Rockwell A74-A75

8. Established and maintained documentation for all inspections, tests, and raw material traceability.

C. Joining Cap to Body

1. Laser Welding

Avco has elected laser welding as its candidate technique for joining the cap and body after review of several possible methods. The decision was based on the following:

a. Duty Cycle--Specifically, the Avco Everett laser has adequate power to insure a full penetration weld around the entire periphery of the grenade cap/body interface in approximately one second.

b. The laser produces a narrow, deep weld with a minimum heat affected zone.

c. The laser is readily adaptable to automated tooling for high production runs and could produce approximately two thousand assemblies per hour.

d. The laser was available for this production study program.

e. Minimal Welding Flash--Can be controlled and possibly reduced by improved production tooling.

## 2. Inertia Welding

Avco, after discussion with a company involved with inertia welding equipment, machined several sets of parts to be joined by inertia welding. After welding, the heavy welding flash was machined from the outer and inner surfaces of the grenade body.

Data obtained from the vendor indicated that the inertia welding equipment could be automated; however, its throughput would be approximately eight hundred assemblies per hour, which is significantly slower than the laser.

## 3. Electron Beam Welding

Avco had discussed with a producer of electron beam welding equipment the viability of using their equipment for joining the cap and body.

It was felt that the cap and body could be joined by electron beam. The details of the joint would have to be somewhat different than the current Avco reference design. However, due to limitation in time and funds, the electron beam welding technique was not pursued beyond preliminary discussions.

## 4. Brazing

Furnace brazing has been used for many years as a method of joining metal parts into an assembly. Avco decided to machine several caps and bodies and have them brazed in a hydrogen atmosphere using a copper filler.

A push test was performed on two assemblies, using Tinius Olsen test equipment, to determine strength of the brazed joint. In both cases the cap separated from the body at the brazed joint, one failing at 13480 pounds and the second at 16860 pounds of force. An examination of the failed joint indicated complete wetting of the surfaces with minor porosity.

It was concluded that vacuum brazing of the cap and body did not lend itself to a high volume automated process, and any further work in this area discontinued.

## D. Structural Analysis

### 1. Introduction

The proposed design configuration of the M42/M46 grenade body that has been analyzed in depth is a two-piece body, welded at the interface (see Figures 1 and 2). The Avco grenade body configuration conforms to the dimensional requirements imposed by the ARRADCOM drawings for Body Type PH (#9215344) and Body Type CA (#9215374), as well as the notes related to specific details of the drawings. The knurl pattern sizing was configured to give fragments of approximately 2 grains. The body was to be analyzed for two unique loading conditions specified in MIL-G-50546 and MIL-G-48047, both documents indicating a longitudinal loading on the body and a lateral loading--65,000 pounds (min.) axially and 6300 pounds (min.) transversely on body type PH and 85,000 pounds (min.) axially and 7500 pounds (min.) transversely on body type CA. Besides these main loading conditions, investigations into the weld type, technique, and structural implications were also assessed as well as the final material selection for the two-piece designs. The primary loading cases were analyzed using an in-house computer program, "SAMS" (Shell Analysis Modular System). This is a finite difference technique used for either static or dynamic elastic shell responses.

Two additional load cases were investigated during the course of the analytical task to better understand the overall environments the grenade body must withstand and to assist in formulating some conclusions about body structural integrity and weld joint deformations. The cases are (a) set-back loading in the cap due to the high initial acceleration imposed by the in-bore environment and (b) loading on the cap due to the forces imposed by the compaction of the explosive mixture during its loading process.

### 2. Loading

The four loading cases explored during the structural analysis of the grenade body are defined below. Their loading magnitude and direction are shown in Figure 10.

Case I      Axial compression of shell body due to inertial loading imposed by acceleration forces.

M42/M46 LOADING CASES

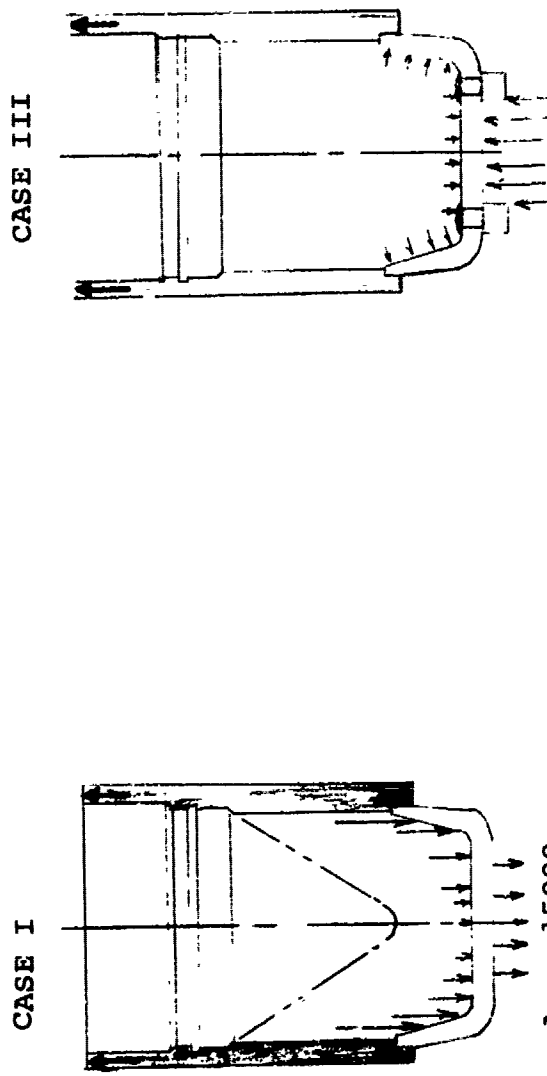
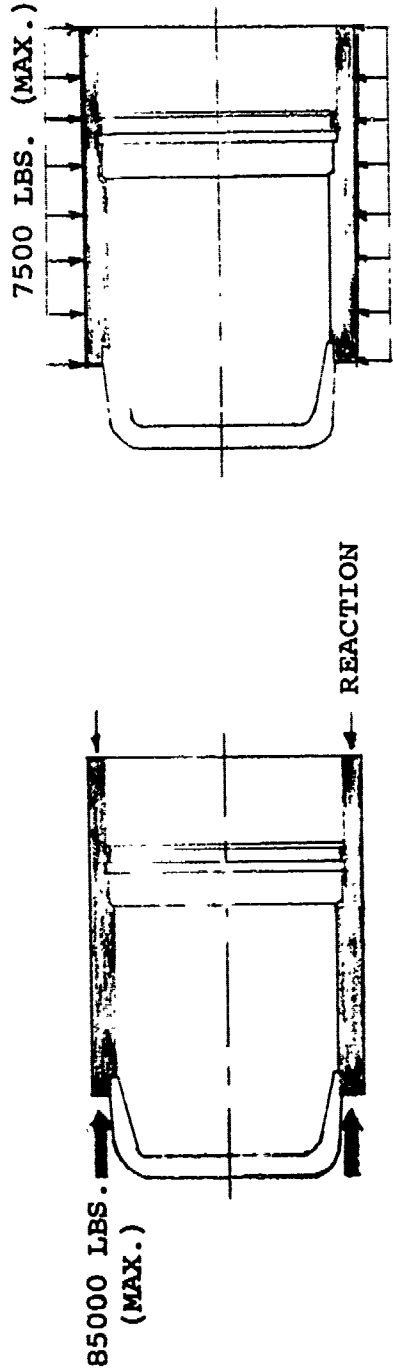

FIGURE 10



- Case II      Axial loading of cap due to set-back forces imposed by weight of fuze and explosive mixture.
- Case III     Transverse line load applied on diametrically opposed lines along the length of the shell body.
- Case IV     Axial and radial loads (normal forces to the shell reference surface) applied to the cap due to compaction of explosive mixture. Center of cap, between stud locations, is supported while loading is in process.

Cases I, II, and III derive their loading forces from the in-bore pressure pulse environment, which accelerates the projectile to a 15,000 g condition. Case IV forces occur outside the gun environment at a particular point in the assembly of the system or the charge loading of a specific grenade body. Under these load conditions, shell analyses were conducted using the "SAMS" code as described in the ensuing paragraph.

Case III, specifically, has a load input parameter that is governed by Fourier harmonics in order to represent the opposing line loads adequately. Figure 11 indicates the symmetric harmonic loading incorporated into the "SAMS" program. A number of trial distributions and varying number of harmonics were used before this condition was judged the closest approximation to the actual load. A series of coefficients for the appropriate harmonics were used, corresponding to the normalization of the maximum line load at 0 degrees and 180 degrees. It can be seen from the figure that the oscillations after 7.5 degrees are very small so that this input does represent, to the best degree possible for the scope of the problem, a good approximation of the actual line loading.

### 3. Analytical Technique

The shell model used for the structural evaluation of the grenade body in the SAMS computer code is shown in Figure 12. This finite difference code handles orthotropic multilayered and multiregion shell configurations under arbitrary static or dynamic loading, circumferentially or longitudinally. The format for this code requires that the selection of an idealistic reference line, defining the shell configuration, be as realistic as possible for the complexity of the shell. Input parameters, such as shell thicknesses, are then referenced to this line.

NORMALIZED LOADING FOR CASE III  
HARMONIC FIT TO IDEALIZE TRANSVERSE LINELOAD  
AT 0° AND 180°

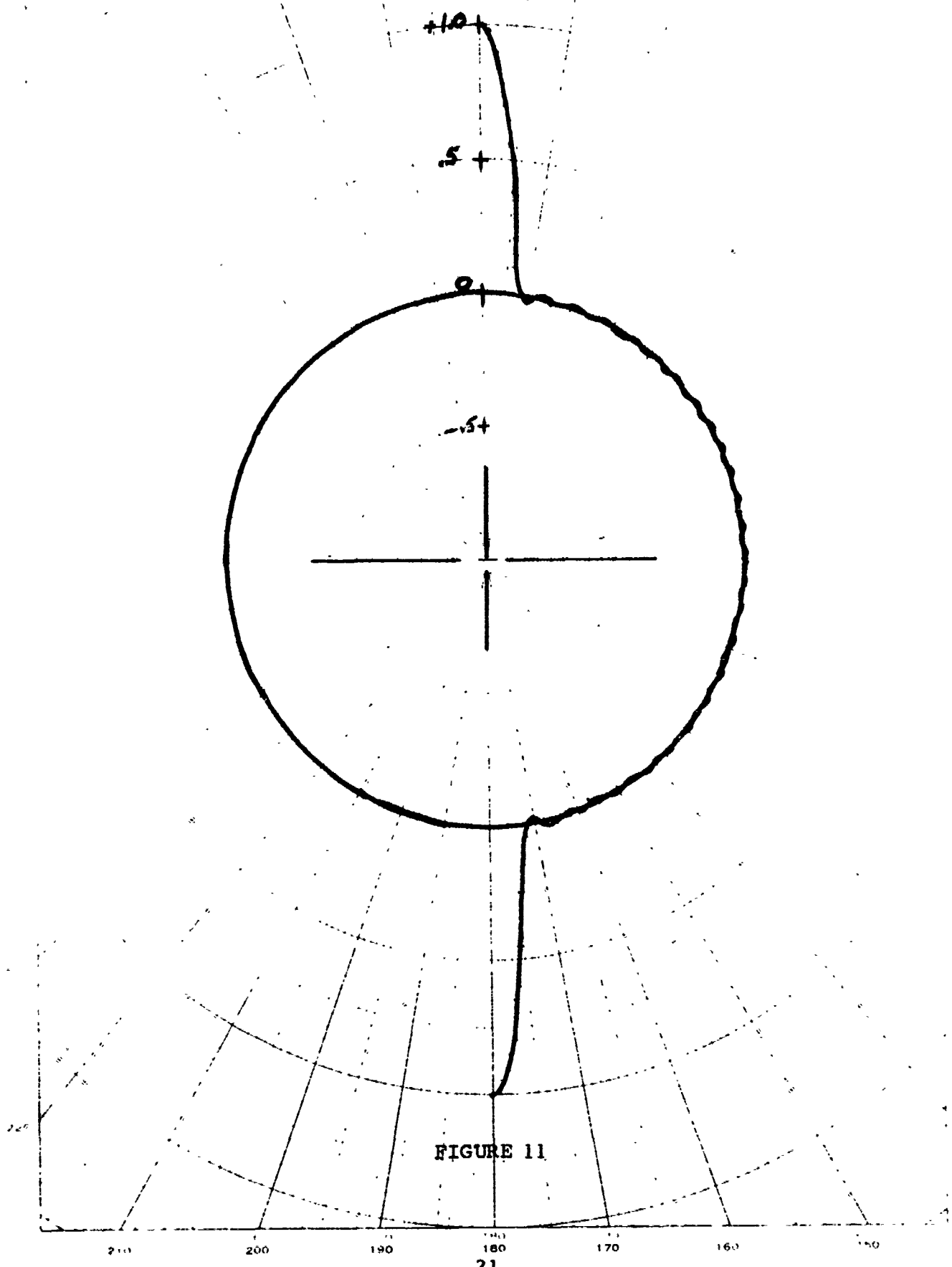
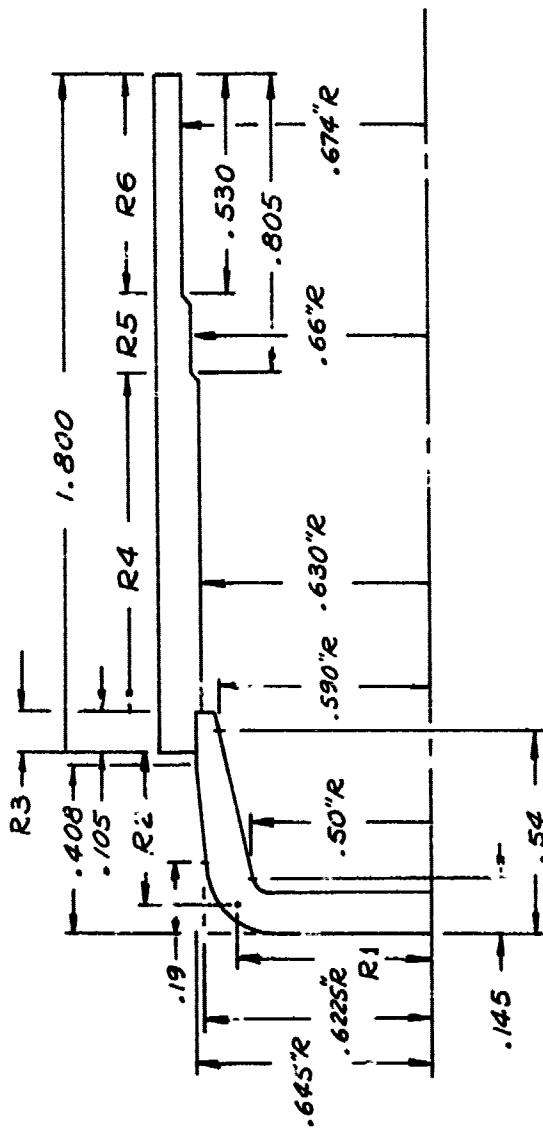

FIGURE 11



Regions Used for SAMS Computer Run

Figure 12

Figure 13 shows in greater detail the formation of point to point positions of the reference line and the approximate number of increments used to specify the cap and weld joint regions. It should be noted that the regions have overlapping incremental divisions where the regions merge; therefore, some discretion must be used when examining the resulting output stresses and deflections at these points, especially Region 3 where the cap is connected to the body. The boundary conditions used in this analysis are as follows. For Cases I, II, and III, the center of the cap is free to move axially and radially, but the rotation is zero at this point of symmetry. The aft end is simply supported. For Case IV, the origin, at the cap, is free; however, elastic restraints are provided at all shell increments out to the stud areas to represent the center support fixture present during the explosive compaction process. The aft end again is simply supported; however, its restraint should have very little effect on the cap deformation and stresses. This assumption also applies for Case II. The input parameter for shell thickness is a critical dimension in this problem, and for that reason care is used to input a variable thickness along the shell length to represent the structure adequately. Minimum dimensions are used to give maximum stresses and deflections.

#### 4. Results

##### a. Shell and Cap Analysis

A series of tables and curves are presented to give the final results for the four (4) cases input into the SAMS program. Tables 1 and 2 depict the maximum stresses, either axially or circumferentially, of the shell membrane and shell bending stresses respectively. The margins of safety indicated are based on the yield strength of the material. The curves illustrated in Figures 14, 15, and 16 show inner fiber and middle fiber stresses along the total shell body for load Cases I, II, and IV respectively. The inner fiber stresses compared to the middle fiber stresses indicate the bending stress occurring in the shell wall due to the load-line-of-action changing as it moves down the length of the variable thickness shell. The membrane stresses indicate the basic uniform tensile or compressive loading in the shell wall. The curves, illustrated in Figures 17, 18, 19, and 20, show inner and outer fiber stresses along the total shell body; these are bending stresses. The peak stresses, spikes seen in the curves, are subject to some discretionary judgment, as mentioned earlier, due to the modeling technique. Specifically, the peaks shown at arc length of 0.55 inches represent a minimum thickness at the corner; whereas in reality the filleted corner is thicker, and

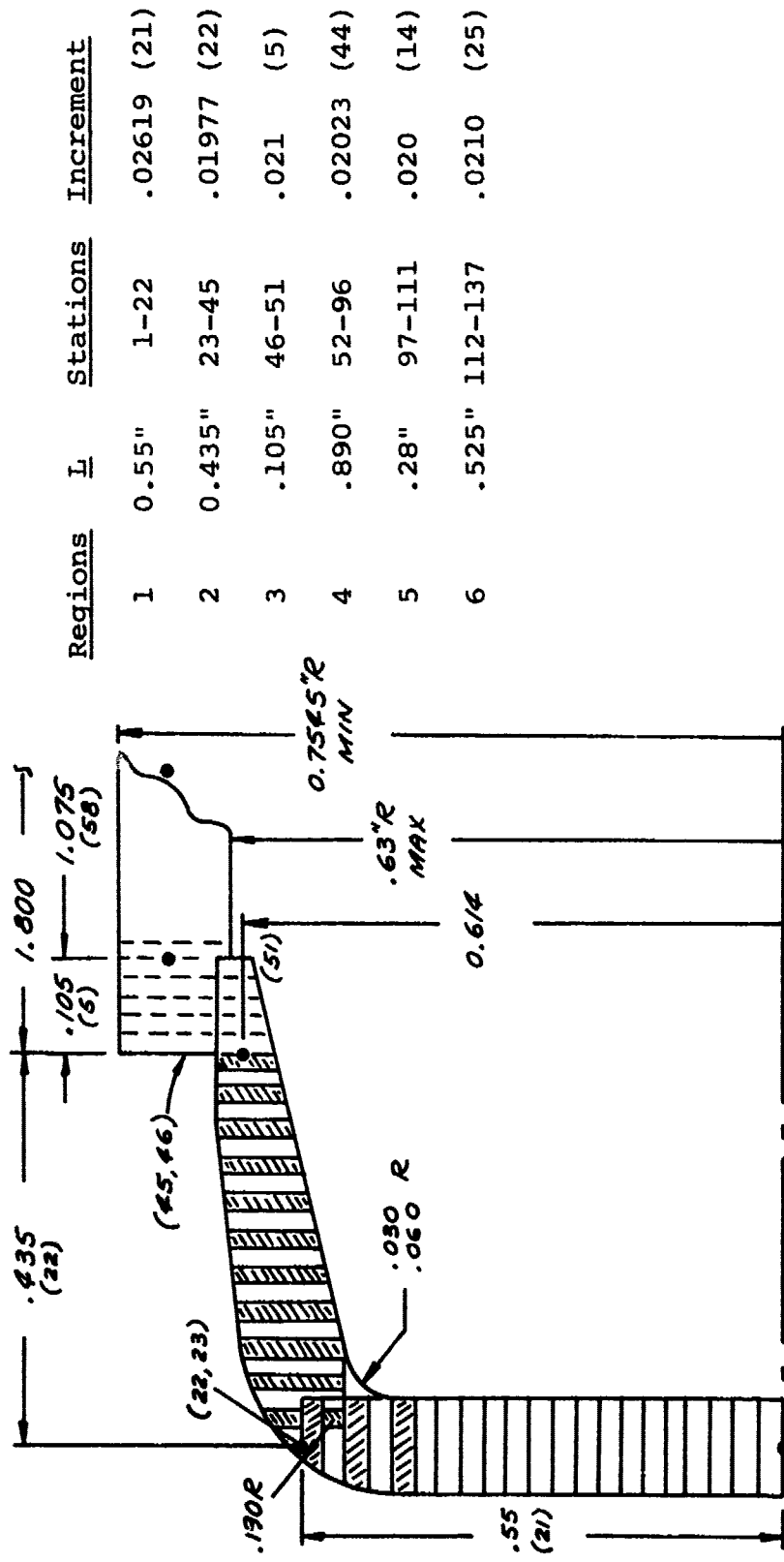

<u>Regions</u>	<u>L</u>	<u>Stations</u>	<u>Increment</u>
1	0.55"	1-22	.02619 (21)
2	0.435"	23-45	.01977 (22)
3	.105"	46-51	.021 (5)
4	.890"	52-96	.02023 (44)
5	.28"	97-111	.020 (14)
6	.525"	112-137	.0210 (25)

CAP INCREMENTS

Figure 13



TABLE 1

BODY MEMBRANE STRESSES (1,2) (MAX.) -  $\sigma_x$  or  $\sigma_y$   
MARGINS OF SAFETY (3)

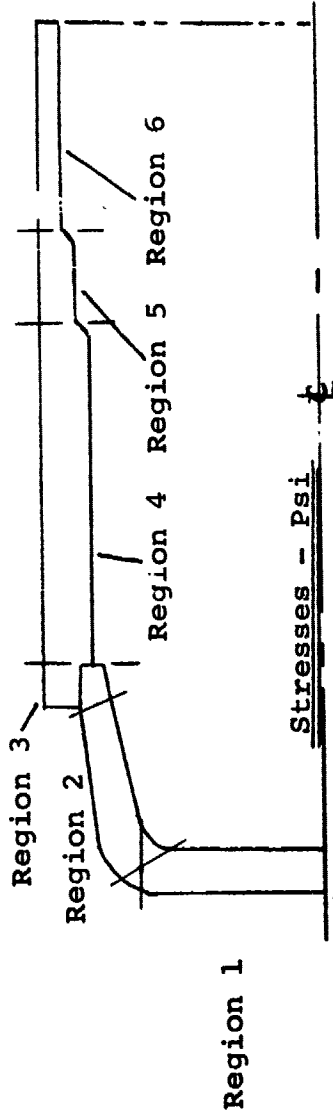

REGION	CASE I		CASE II		CASE III		CASE IV	
	STRESS (2)	M.S.	STRESS (2)	M.S.	STRESS (2)	M.S.	STRESS (2)	M.S.
1	0	---	-3903 (2.64)	Ample	-2320 (1.6)	Ample	-12935 (8.92)	Ample
2	-285 (110.0)	Ample	-6341 (4.37)	Ample	4506 (3.1)	Ample	-48702 (33.6)	3.8
3	-159642 (110.0)	0.46	-1772 (1.22)	Ample	-7330 (5.05)	Ample	-25471 (17.56)	8.1
4	-159642 (110.0)	0.46	-3026 (2.09)	Ample	-5720 (3.94)	Ample	-10787 (7.44)	Ample
5	-198588 (136.9)	0.17	-3764 (2.6)	Ample	-8647 (5.96)	Ample	-12194 (8.41)	"
6	-229942 (158.5)	0.01	-4358 (3.0)	Ample	-13479 (9.29)	16.2	-14118 (9.73)	"

- NOTES:
1. Material--Cap and body, 4140 heat-treated steel. Rockwell A 76.0 hardness rating (FTU = 259 KSI; FTY = 90% FTU = 233 KSI).
  2. Stress values shown in parentheses ( ) are in  $10^7$  Newton/M<sup>2</sup>.
  3. Margins of safety based on yield strength.

TABLE 2

BODY BENDING STRESSES (1,2) (MAX.) -  $\sigma_x$  or  $\sigma_\theta$   
 MARGINS OF SAFETY (3)

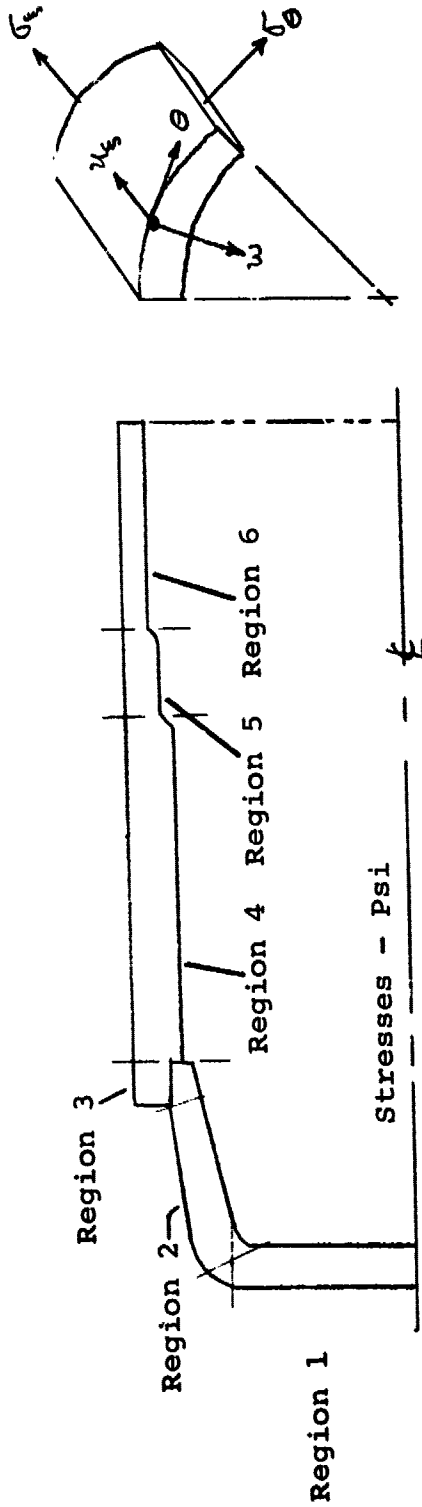

REGION	CASE I		CASE II		CASE III		CASE IV	
	STRESS (2)	M.S.	STRESS (2)	M.S.	STRESS (2)	M.S.	STRESS (2)	M.S.
1	0	---	19864 (13.6)	10.8	-12438 (8.58)	Ample	-46890 (32.4)	4.0
2	-1607 (1.11)	Ample	-15854 (10.9)	Ample	16024 (11.05)	"	-37317 (25.7)	5.2
3	-161396 (111.3)	0.44	-5099 (3.52)	↓	18120 (12.49)	"	-23501 (16.2)	8.9
4	-161396 (111.3)	0.44	-6715 (4.63)		39799 (27.4)	4.8	-37599 (25.9)	5.2
5	-207947 (143.4)	0.12	-3729 (2.57)	46209 (31.8)	4.0	-12182 (8.4)	Ample	
6	-268994 (185.4)	*	-5119 (7.53)	Ample	46724 (32.2)	4.0	-16623 (11.5)	"

\*Plastic analysis here indicates only a 0.9% plastic strain; this is considered to be within the resilience of the material and does not imply structural failure.

- NOTES:
1. Material--Cap and body, 4140 heat-treated steel.  
 Rockwell A 76.0 hardness rating (FTU = 259 KSI; FTY = 90% FTU = 233 KSI).
  2. Stress values shown in parentheses ( ) are in  $10^7$  Newton/M<sup>2</sup>.
  3. Margins of safety based on yield strength.

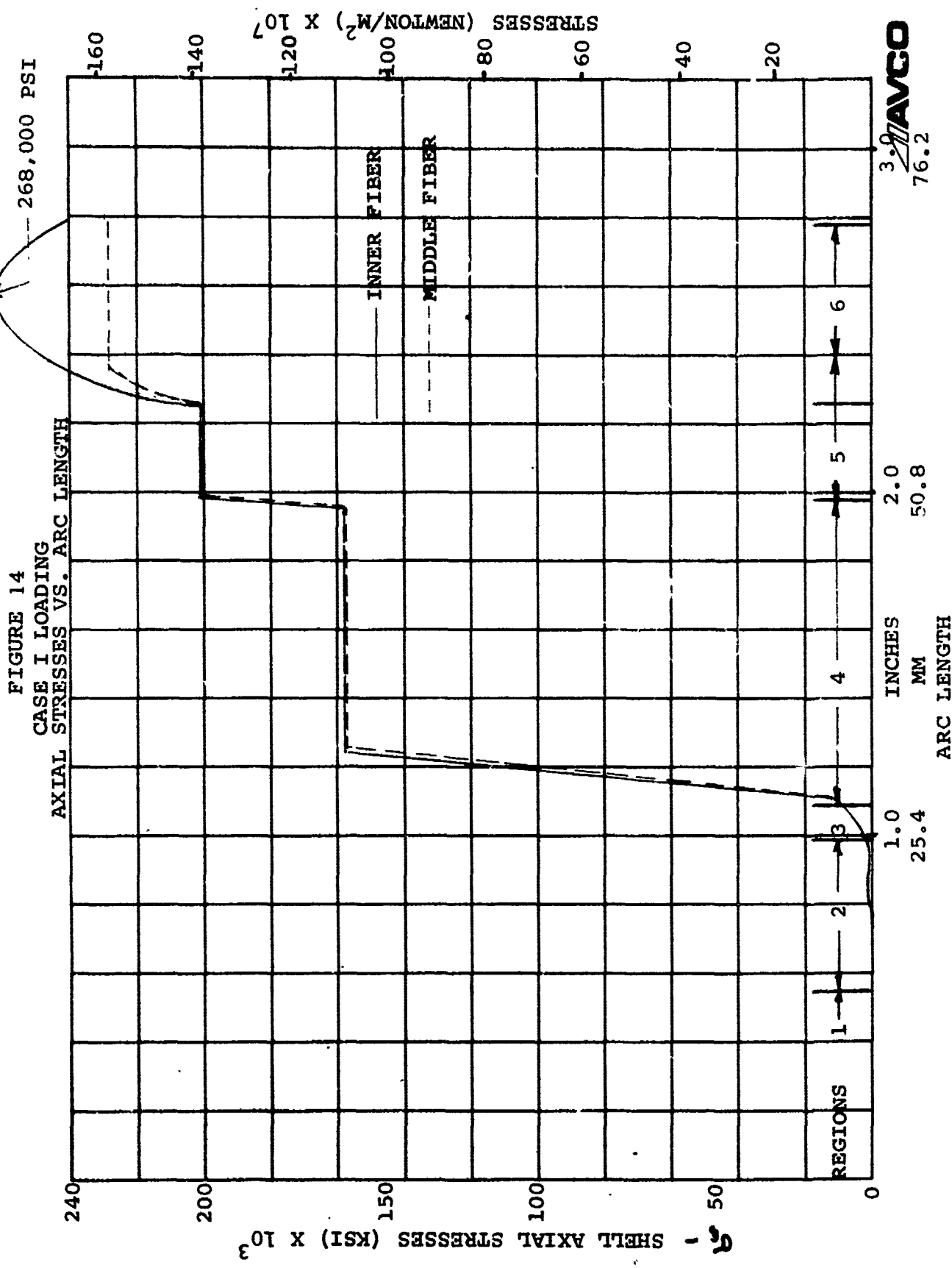

**AVCO**  
 3.0  
 76.2

FIGURE 15

CASE II LOADING

AXIAL STRESSES VS. ARC LENGTH

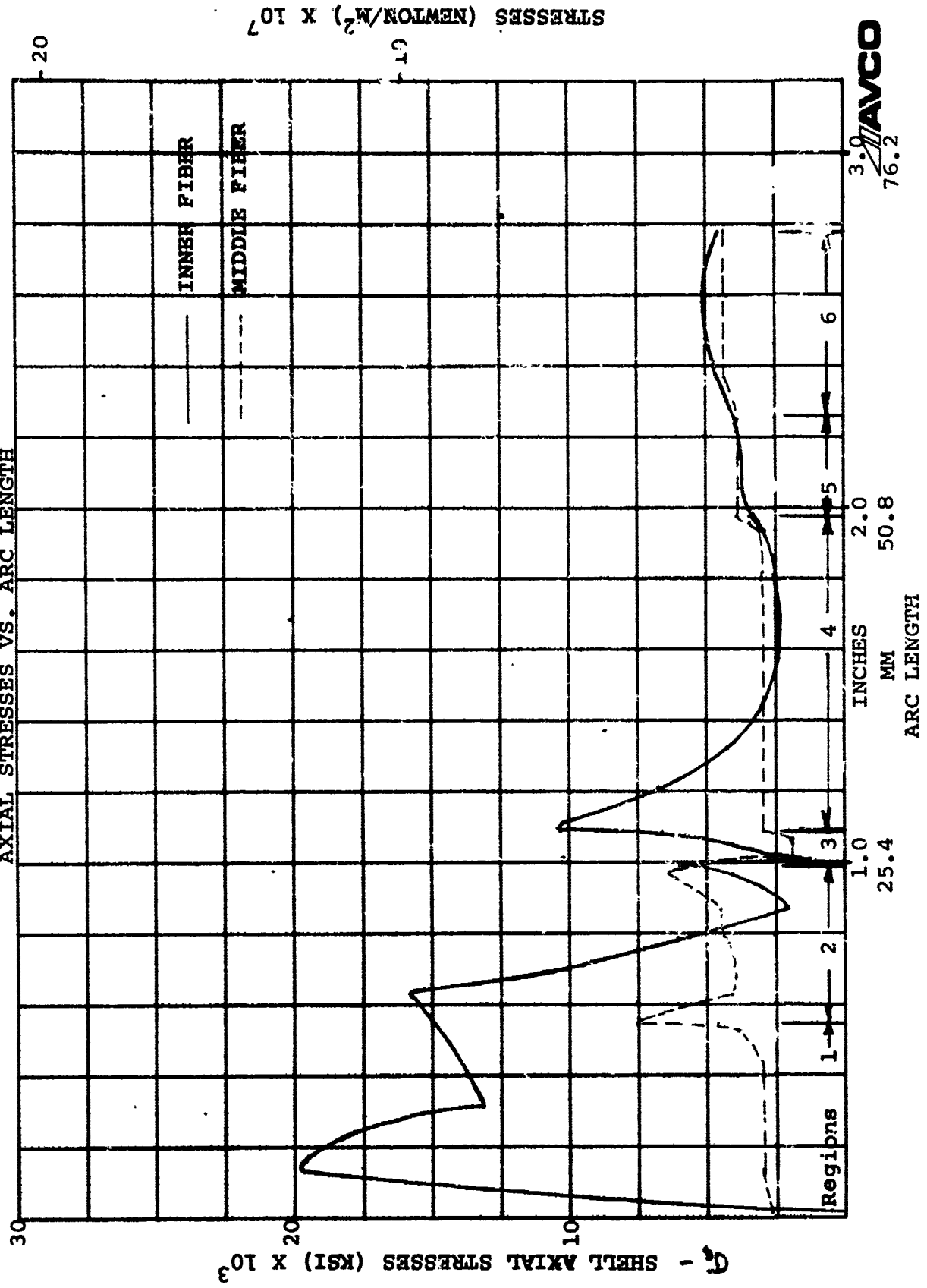
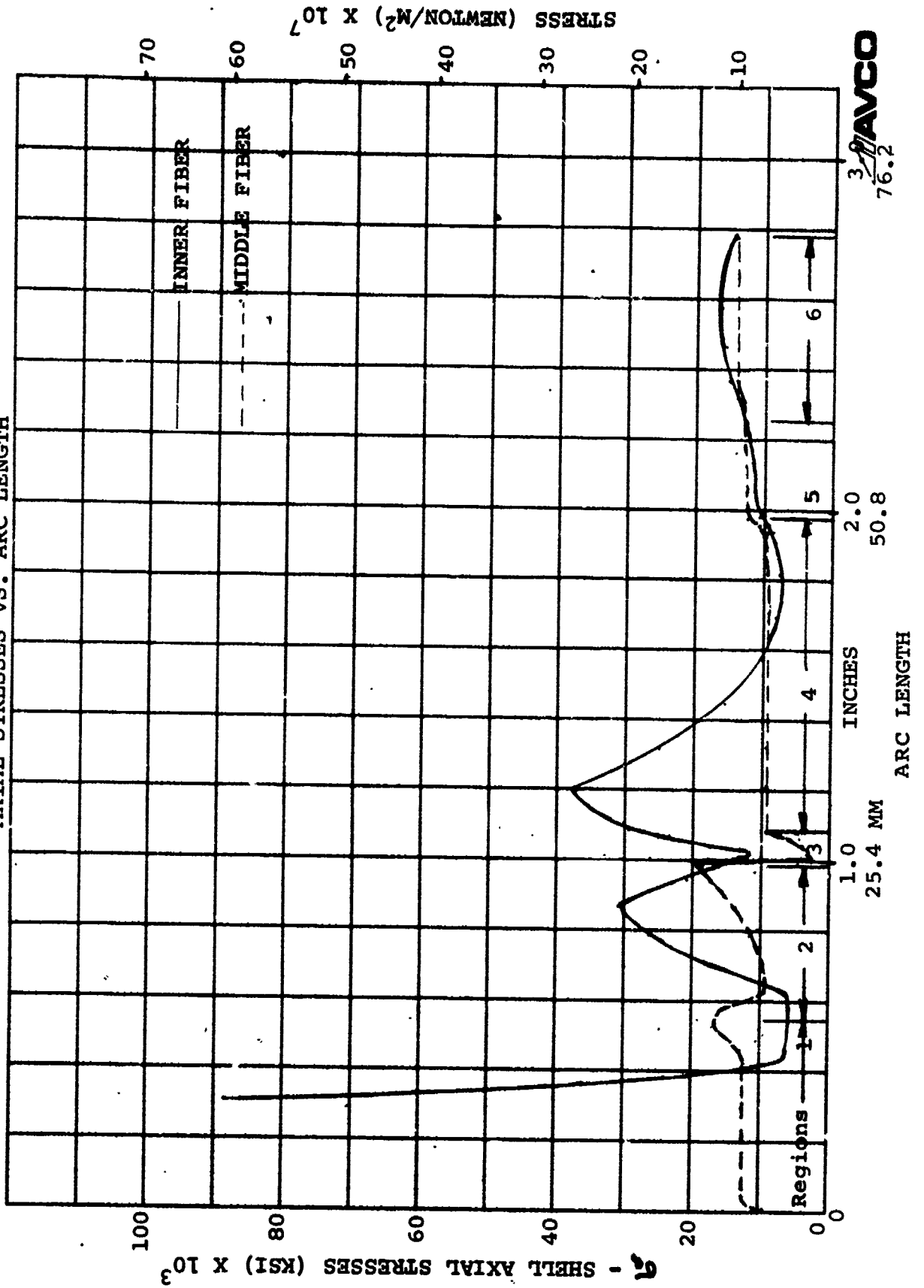

FIGURE 16  
CASE IV LOADING  
AXIAL STRESSES VS. ARC LENGTH



3 AVCO  
76.2

1-1688

FIGURE 17  
CASE III LOADING  
AXIAL STRESS (INNER FIBER) VS. ARC LENGTH

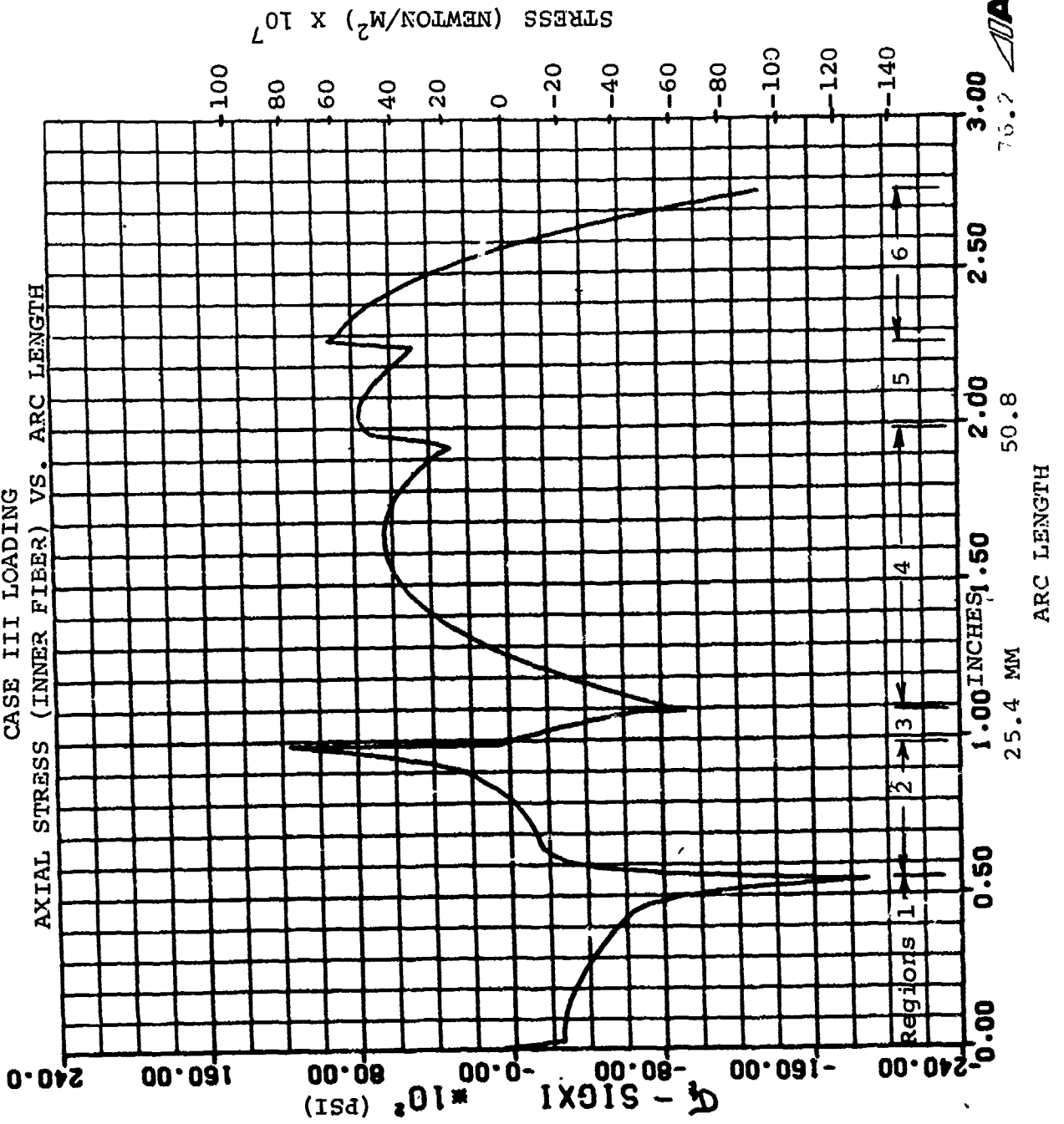

1-1688

FIGURE 18  
CASE III LOADING  
AXIAL STRESS (OUTER FIBER) VS. ARC LENGTH

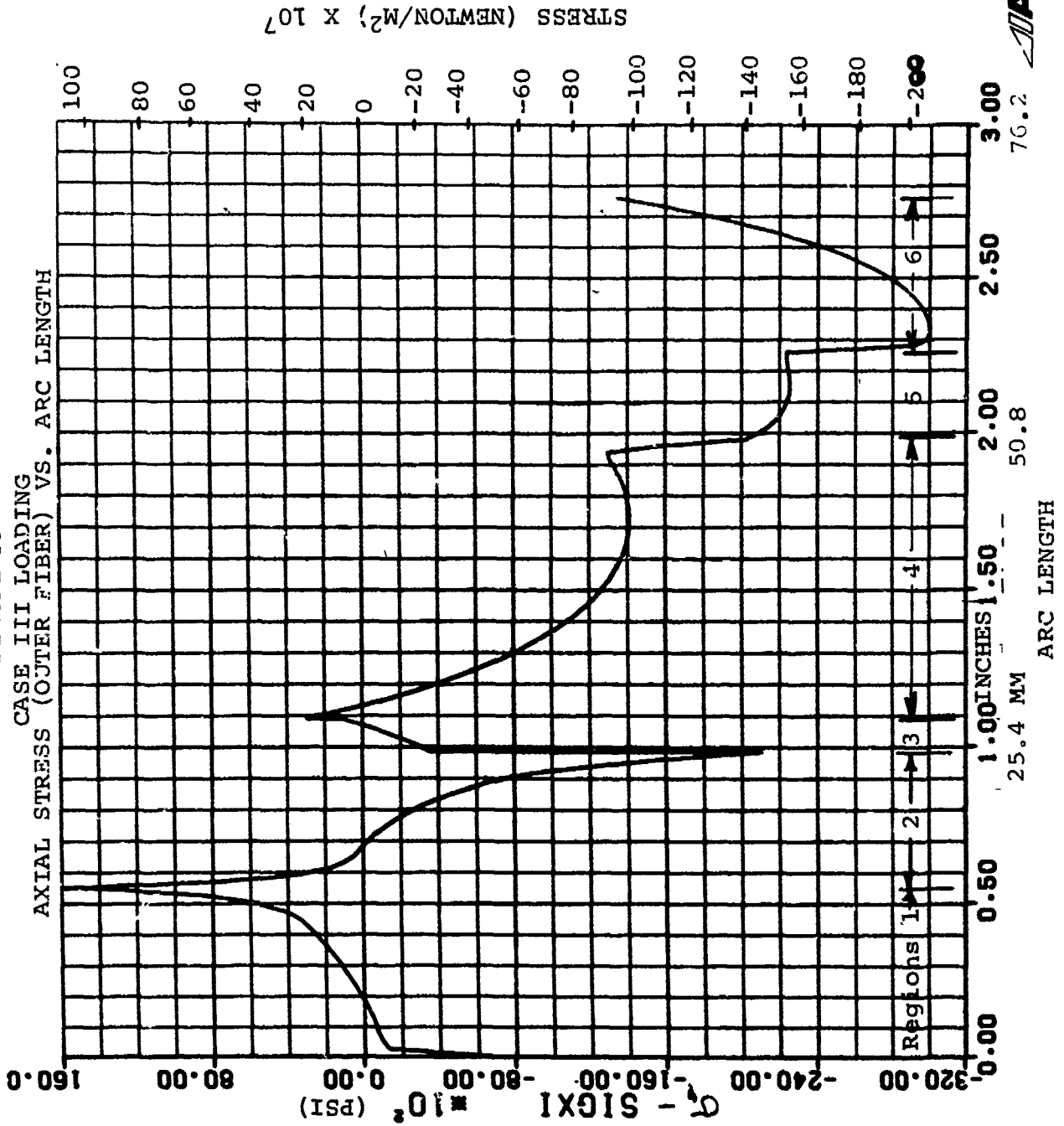

1-1688

FIGURE 19  
CASE III LOADING  
HOOP STRESS (INNER FIBER) VS. ARC LENGTH

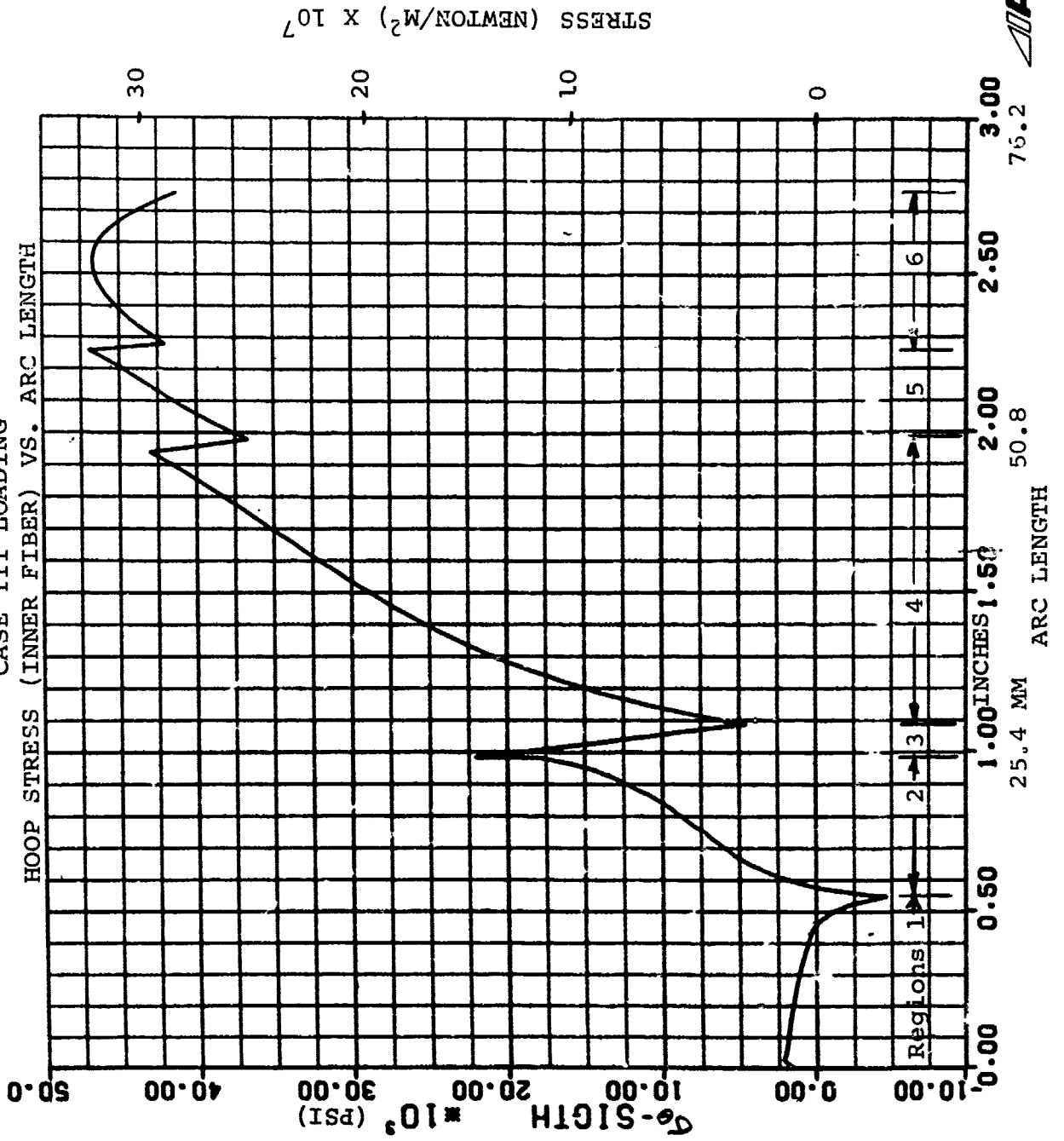

1-1688

FIGURE 20  
CASE III LOADING  
HOOP STRESS (OUTER FIBER) VS. ARC LENGTH

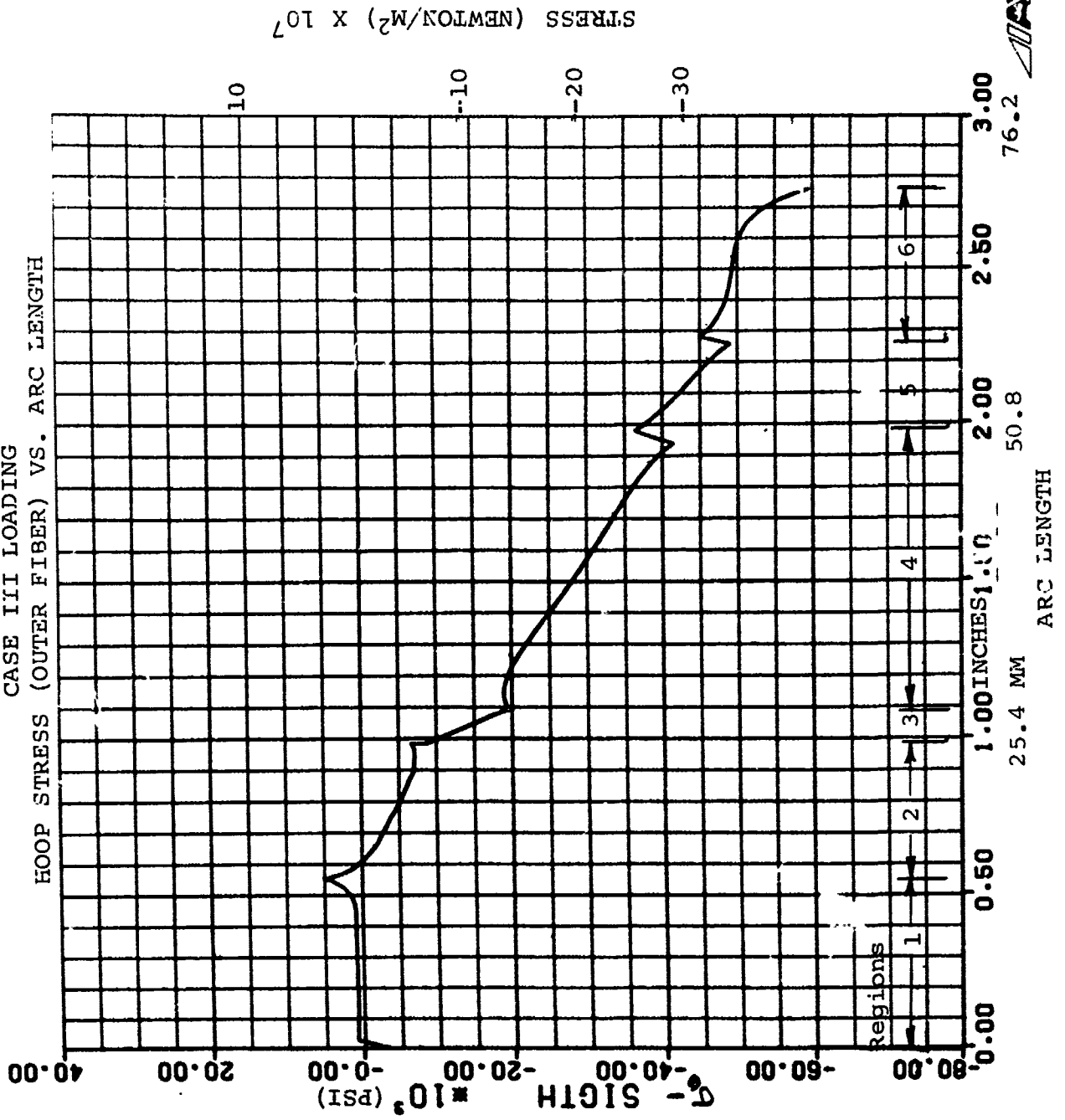

stresses at this point would be reduced some degree. These peak stresses are still within the yield strength of the cap material, but not as marginal as the curves might indicate. In most cases, for a minimum thickness shell geometry, the stresses are within the elastic range of the 4140 steel properties. It is quite apparent that Case I loading imposes the severest stresses and in Region 6 does exceed the elastic limit. However, a calculation was made of the plastic stress and strain based on an energy method approach, using the plastic portion under the stress-strain curve to give an indication of the degree of plastic action used. The value of plastic strain was 0.9 percent, well within the strain to failure of approximately 10 percent for a 4140 heat-treated steel of Rockwell hardness A 76.0. This plasticity is considered to be only a slight strain beyond the elastic limit, and the materials used have sufficient resiliency to accommodate these strains without any critical deformations or catastrophic failures. This supposition will actually be enhanced by the structural testing to be accomplished for Cases I and III.

Since the shell model was based on minimum thickness properties with maximum loads, it was felt that this combination depicted worst case stresses. An increased wall thickness of 10.8 percent from the 0.1245 inch minimum would in effect lower the membrane stresses by that amount. Since the shell bending stresses can be formulated simplistically by a  $6M/t^2$  equation, the bending stresses would be reduced by approximately 20 percent by using the maximum wall thickness.

The depth of the knurled groove (.010"-.017") on a minimum thickness wall is approximately a 10 percent reduction. However, the loads applicable for this configuration are approximately 23.5 percent less than the maximum axial loading and 16 percent less than the maximum transverse loading. This combination of conditions thus imposes a neutralizing effect on the knurled concept, and the methodology of using minimum thickness geometry and maximum loadings still remains the severest condition when assessing the end results of our analytical effort. Effects of this knurl depth, in addition to abrupt changes in the shell wall cross-section due to grooves or chamfers, are considered minimal in terms of stress risers for all loading conditions. This effect, or lack of it, will be substantiated by the static load tests.

#### b. Weld Analysis

The welded interface is of particular significance in the overall assessment of the grenade body. The weld call-out is for a Class 1 type weld with 100 percent penetration to assure a complete

homogeneous joint with no surface porosity. This area is Region 3 in the "SAMS" shell model, and from Tables 1 and 2 the maximum stresses acting in this area are well within the capability of the as-welded material strength of 4140 steel with a hardness of Rockwell A 76.0. A series of weld tests have been conducted during the course of developing the laser weld process for this body. Although these tests have been reported in the monthly reports, it is significant here to refer again to the latest series of tests. In these, three specimens were used to conduct axial tensile tests on the welded interface. Even with two out of three of the specimens exhibiting exterior porosity, the breaking strength of all three specimens was very consistent at approximately 26,250 pounds. This was failure in the cap mainly, not in the weld; but the weld did see that magnitude of loading. This tensile load is much greater than any load condition the weld is subjected to during either loading or firing. Assuming 90 percent of the yield strength (233 KSI), or approximately 210 KSI, as the as-welded joint strength of Region 3, the maximum stress at this point is 161,396 psi in a compression state due to Case I loading. In all cases the inner fiber stress state is compression and varies from 5100 psi in Case II to 23,500 psi in Case IV. None of these values jeopardize the structural integrity of the weld. The other important aspect of this welded joint is the degree of deformation it undergoes during the various loading cases. At the junction of Regions 3 and 4, where the possibility of gapping has been alluded to, a compression state exists. The deformation for Case IV loading (compaction of explosive) is approximately 0.6 mils compression (see Table 3). Therefore, when compaction pressure is released, the critical area is expanding, not contracting; and the pinching of propellant grains is very unlikely. However, under the Case I loading, axial compression of the body under the acceleration forces, the body deformation is on the order of 15 mils. This deformation, at least two magnitudes greater than the other loading cases, occurs as a uniform elastic deformation of the grenade body. Its occurrence takes place for our design as well as the presently configured embossed cup and draw method with its attendant grooves. Therefore, for this relatively large deformation, there is no difference between the present design and our welded design. As long as surface porosity is not allowed at the welded joint, the "pinching" effect on the explosive grains does not appear to govern the integrity of this welding process.

### c. Material Selection

The final material selection consisted of a few iterations on the cap material only, since the body material remained similar to the ARRADCOM choice. A low carbon steel cap was once deemed acceptable since the forces on it were considered relatively small. Other factors though, such as weld compatibility and a very limited supply, dictated a change to the present 4140 steel.

TABLE 3  
DEFORMATIONS AT WELDED JOINT

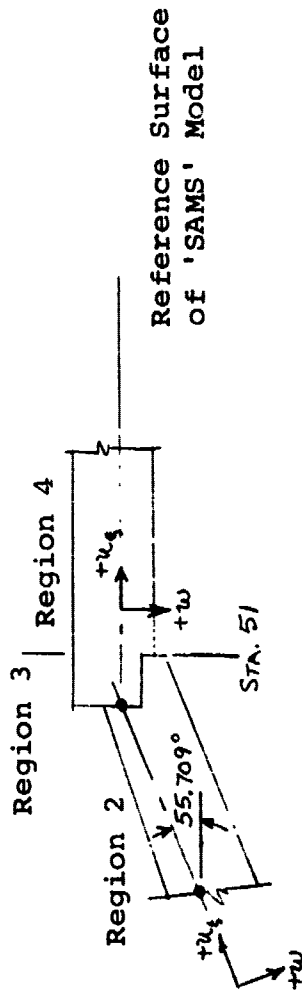

AXIAL DEFLECTION ( U ) AT STA. 51

'SAMS' PROGRAM OUTPUT

CASE I	-	0.152"
CASE II	-	0.00015"
CASE III	-	0.00048"
CASE IV	-	0.00063"

d. Testing

The structural testing of the M42/M46 grenade body has been conducted. Six production-type specimens were used to accomplish three tests of the axial loadings and three tests of the transverse loadings--Cases I and III, respectively. The specimens used were of body type PH, having the knurled configuration, heat treated to Rockwell A 73.0 and required to sustain an axial loading of 65,000 pounds (min.) and a transverse loading of 6300 pounds (min.). The following table lists the results of testing using the Tinius-Olsen tensile testing apparatus.

	<u>Specimen No.</u>	<u>Failure Load (lb.)</u>	<u>Load Rate (inches/min.)</u>
Transverse Loading	1	10,500	.025
	2	9,750	.025
	3	9,480	.025
Axial Loading	4	97,700	.025
	5	96,100	.025
	6	95,000	2.0

Within the constraints of the loading apparatus, reading the load dial and manufacturing tolerances on the individual pieces, all specimens of each load group failed at approximately the same load level. These failure loads are well above the specified minimum requirements for either body type. The smooth wall configuration requirement is 85,000 pounds axially and 7500 pounds transversely with a body hardness rating of Rockwell A 76.0. Thus, in consonance with the postulation previously made, the knurled pattern and/or abrupt cross-sectional changes in area do not appear to significantly impair or reduce the grenade body's capacity to carry the imposed loads. Therefore, these tests substantiate that the worst case loads can be adequately supported by the minimum thickness configuration of a sampling of production-type grenade bodies.

5. Conclusion

An overall assessment of the M42/M46 Grenade Body has been completed, and it has been shown to be structurally capable of withstanding all the known environments imposed on it under this task description.

## SECTION IV

### PRODUCTION PROCESS - PROPOSED

The Avco proposed production process is depicted on Figure 21. A description of each of the manufacturing processes and product assurance activities is presented in subsequent paragraphs and follows the proposed production flow sequence.

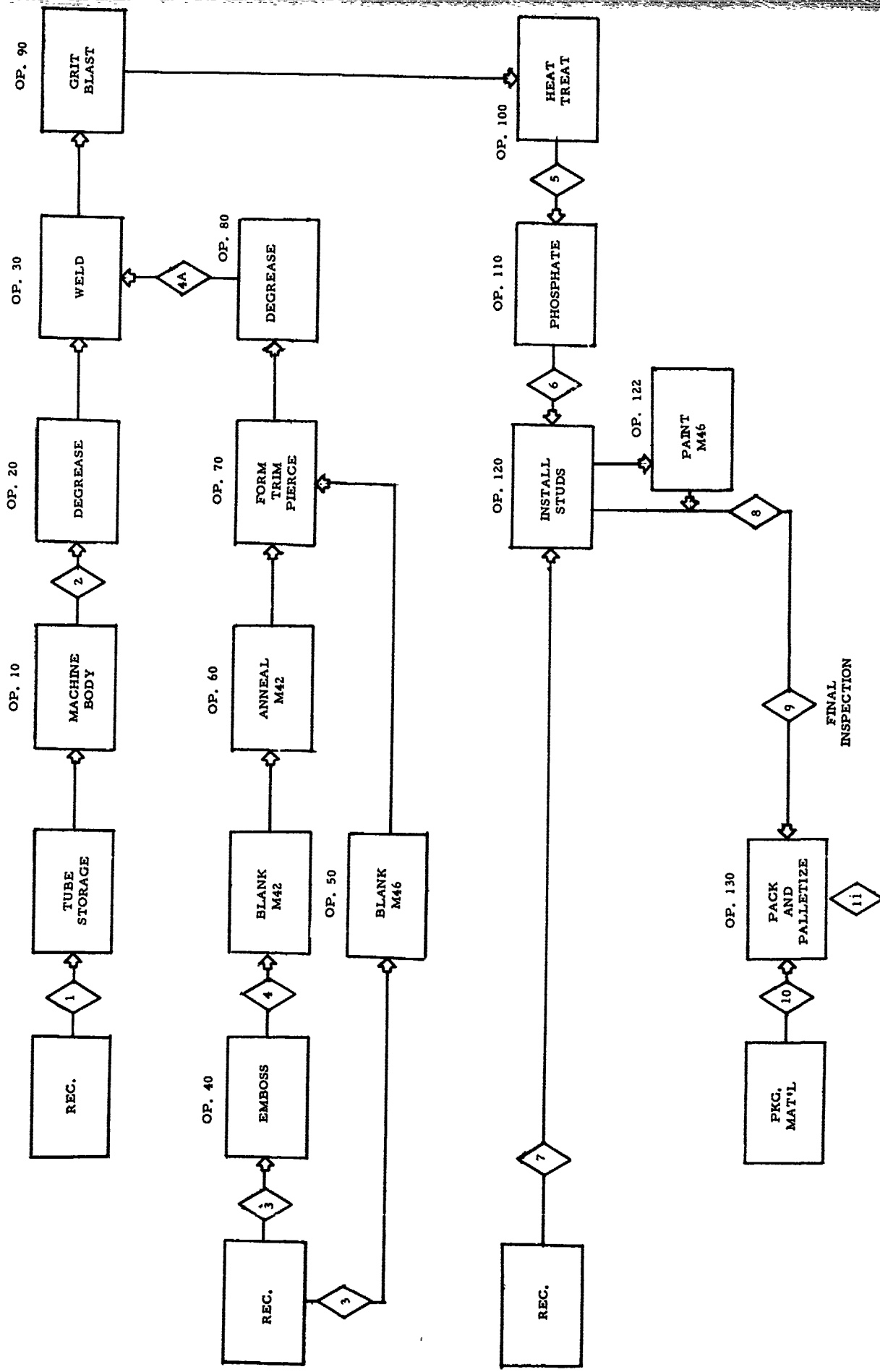

◆ PRODUCT ASSURANCE CHECK

M42/M46 GRENADE FLOW CHART

FIGURE 21

PRODUCT ASSURANCE  
OPERATION 1

Receiving Inspection - Tubing

1. Dimensional Inspection--Outside diameter, wall thickness, length.
2. Visual Inspection--Damage, identification.
3. Review vendor's certification for compliance with material specification.
4. Review vendor's certification for compliance with proposed 100 percent ultrasonic inspection of tubing for cracks.

## OPERATION 10

### Body Machining

Tubing is magazine fed automatically into the stock reel tubes of the six-spindle bar machine. This eliminates the downtime for loading and permits uninterrupted production. The tubing end is faced for squareness, and the internal configuration of the body is machined. The knurling and the removal of the knurl points on the M42 only completes inside body machining. The outside diameter of the body is machined, the corners are chamfered, and the completed part is cut off from the tube. The parts are deposited on a conveyor, where the excess lubricants and chips drain into collectors, while being moved to the degreaser.

Chips from the machining operations are continuously collected, separated, and removed to storage bins by conveyor.

Lubricant flows back into the reservoir, which is complete with filters and large enough to permit sufficient cooling and filtering of the lubricant before recirculation.

Cutting tools will be carbide or carbide-tipped, held in precision pre-set tool holders. The cutting tool in each tool holder is adjusted to the proper position by using accurate gages. The tool setting is done on the bench, while the machine is operating, increasing uptime of the machine.

The following descriptive data applies to a National-Acme bar machine. However, it is to be noted that other bar machines, such as New Britain or Conomatic, may be used to accomplish the task described above.

Capacity	553 per hour
Spindle speed	821 rpm
#6 spindle	Feed bar - face end
#1 spindle	Rough bore 1.347 and 1.326 dias.
#2 spindle	Turn O. D. bore 1.260 dia. and finish bore 1.326 and 1.347 dias.
#3 spindle	Knurl I. D.
#4 spindle	Recess all diameters
#5 spindle	Ream knurl points (M42 only). Cut off.

PRODUCT ASSURANCE  
OPERATION 2

CSP Station #1 - Inspection of Machined Body

<u>C/D</u>	<u>Description of Characteristic</u>	<u>Inspection Method</u>
	<u>Major Class</u>	
02001	Largest outside diameter, min.	Gage
02002	Largest inside diameter, max.	Gage
02003	Concentricity of largest inside diameter with outside diameter	Gage
02004	Second largest inside diameter, max.	Gage
02005	Concentricity of second largest inside diameter with outside diameter	Gage
02006	Third largest inside diameter, min.	Gage
02007	Concentricity of third largest inside diameter with outside diameter	Gage
02009	Length from open end to largest inside basic diameter, max.	Gage
02010	Length from open end to second largest inside basic diameter, max.	Gage
02011	Length from shoulder to open end	Gage
02016	Perpendicularity of shoulder with outside diameter	Gage
02017	Perpendicularity of face of open end with outside diameter	Gage
	<u>Minor Class</u>	
02031	Third largest inside diameter, max.	Gage
02033	Evidence of poor workmanship	Visual

## OPERATION 20

### Automatic Parts Washer and Dryer

Parts are fed to a vibratory hopper and metered into the intake chute of the washer section. The parts are carried through four stages by a helix:

- Soak Stage**      The parts are submerged in the washing solution while gently tumbling and are brought up to washing temperature during this stage.
- Wash Stage**      While gently tumbling and being advanced by the helix, a high volume low pressure spray impinges on the parts insuring a thorough cleaning.
- Drip Dry Stage**    The advance by the helix and the gentle tumbling action allow for a complete drain of all excess solution.
- Blow Dry Stage**    Free moisture within the unit is collected and compressed to form a condensate containing rust inhibitors and is blown on the parts at high pressure. The final blow-off insures a clean dry part to be discharged onto the conveyor.

A pressure sensitive device, which allows for a continuous monitoring of the solution level and for automatic filling, is part of the machine.

An automatic system, which can be used for the M42/M46 grenade body production program, can be procured from Mannor Machine, Crystal Lake, Illinois.

Characteristics of the system are:

Capacity	6000 pieces per hour
Drum speed	5 rpm
Drum diameter	30"
Drum helix	4" high, 9" pitch
Soak time	1 minute
Soak temperature	170°-180°F
Ventilation	Fan rated at 2380 CFM

PRODUCT ASSURANCE  
OPERATION 3

Receiving Inspection - Cap Stock

1. Dimensional Inspection--Length, width, thickness.
2. Visual Inspection--Damage, identification.
3. Review vendor's certification for compliance with material specification.

## OPERATION 40

### Embossing Cap Material (M42 only)

Cold rolled strip AISI 4140 electric furnace ASTM A-507 vacuum degassed 90 percent min spheroids Rockwell B85 max. number 2 finish, number 3 edge oiled will be procured in coils, weighing approximately 2,000 pounds each. These will be transferred by overhead crane to the rolling mill and placed in the coil-stock feed. After unstrapping, the material is run through a straightener, which removes the bends induced by coiling, before being fed through the embossing rolls.

A typical rolling mill suitable for this task can be procured from the Fenn Manufacturing Company, Newington, Connecticut. Their model No. 101 pattern mill with accessories is described below:

1. A two high roller bearing mill equipped with one hardened and ground special alloy steel lower roll mounted in extra heavy duty precision roller bearings. Roll adjustment is accomplished by means of power screwdown. Screws can be adjusted individually or simultaneously by simple push buttons. The rolls are driven by heavy-duty universal joints. Hydraulic roll lifters are also incorporated in this mill.

2. Double arm payoff reel with brakes having the following features:

Capacity	6000 lbs.
Coil I. D.	16 to 20 inches
Coil O. D.	60 inches
Width of Coil	10 inches maximum

3. A separate floor-mounted stock clearing machine, used in conjunction with the rolling mill, consisting of guide rolls and rotating brushes.

4. A take-up reel with the capability of maintaining a constant tension by means of electrical controls.

5. Necessary electrical drives, controls, interlocks, etc., to operate at rolling speeds up to 100 FPM maximum.

PRODUCT ASSURANCE  
OPERATION 4

CSP Station #2

<u>C/D</u>	<u>Description of Characteristic</u>	<u>Inspection Method</u>
0000	Dimensional inspection of embossing	Gage
0000	Evidence of poor workmanship	Visual

## OPERATION 50

### Blanking - Caps

The coil of embossed stock (for M42's) or unembossed stock (for M46's) is loaded onto an uncoiler, where it is unstrapped and the free end started into the blanking die set on the press.

Preliminary inquiries have indicated that a press similar to a Henry and Wright 90-ton single crank dieing machine would be satisfactory to do the job. The press has a friction clutch and brake pneumatically operated and electrically controlled. A shear type scrap cutter with suitable guards is provided with this machine.

Some of the other machine characteristics are:

Strokes - adjustable	100 to 300 per min.
Capacity	90 tons
Bolster Area	41.5 x 16 (RL x FB)
Width of material to be fed	8" max.
Feed pitch - adjustable	0 to 8"
Necessary controls, interlocks, lubricating systems, speed control, etc.	

## OPERATION 60

### Annealing - Cap

The requirement for this production operation is to remove the stresses induced into the cap blanks during the embossing procedure.

An annealing system, designed and fabricated by Sunbeam Equipment Corporation, Meadville, Pennsylvania, can be procured to accomplish the required work.

The equipment is comprised of 1000 pound per hour mesh belt conveyor annealing furnace, 3000 cfh exogas generator and 3000 cfh refrigerant drier and is capable of processing 1000 pounds of cap blanks per hour with a cycle of heating to 1150°F and soak one hour at temperature. The blanks are then cooled in atmosphere through a water-jacketed cooling chamber to a temperature of 600°F before discharging from the furnace atmosphere. After discharge from the furnace atmosphere, the work is fan cooled to approximately 200°F.

The annealing furnace is approximately 95' long x 10' long.

## OPERATION 70

### Cap - Form, Pierce, Trim

The cap blanks will be loaded into bulk hoppers in the press area and transferred by an elevating system to the press in-feed. Incorporated in the feed system will be a sensor for detecting the presence of embossments on the M42 blanks and lack of embossments on the M46 blanks.

The press under consideration is a Waterbury Farrel 300CR7 Transfer Press. It is of modular tie rod weldment construction. Die set tooling will be utilized for easy tool maintenance. Individual die holders and punches will be removable for rapid replacement when necessary. Precision gibbing, having a heavy cross section and long length, is used for long life and accurate guidance of the main slide.

A large, high-energy flywheel is mounted on a geared machine back-shaft to obtain the energy necessary to form the cap.

The transfer system is directly driven from the main shaft by a full-follow cam to provide longitudinal motion. Simple adjustable transfer fingers carry the parts through the successive forming stations.

Individual mechanically-operated part strippers provide a positive method of removing the part from the punch after forming.

An integral coolant tank is included in the machine base. A pump and manifold system deliver the coolant to the tool area.

Following are some of the press characteristics:

Machine tonnage	300 tons
Number of work stations	7
Stroke of cam	8"
Bed area	56.5 x 37.5 (LR x FB)
Tooling center distance (between stations)	6"
Operating speed--strokes per minute	25.50

## OPERATION 80

### Automatic Parts Washer and Dryer

Parts are fed to a vibratory hopper and metered into the intake chute of the washer section. The parts are carried through four stages by a helix:

- Soak Stage**      The parts are submerged in the washing solution while gently tumbling and are brought up to washing temperature during this stage.
- Wash Stage**      While gently tumbling and being advanced by the helix, a high volume low pressure spray impinges on the parts insuring a thorough cleaning.
- Drip Dry Stage**    The advance by the helix and the gentle tumbling action allow for a complete drain of all excess solution.
- Blow Dry Stage**    Free moisture within the unit is collected and compressed to form a condensate containing rust inhibitors and is blown on the parts at high pressure. The final blow-off insures a clean dry part to be discharged onto the conveyor.

A pressure sensitive device, which allows for a continuous monitoring of the solution level and for automatic filling, is part of the machine.

An automatic system, which can be used for the M42/M46 grenade body production program, can be procured from Mannor Machine, Crystal Lake, Illinois.

Characteristics of the system are:

Capacity	6000 pieces per hour
Drum speed	3 rpm
Drum diameter	30"
Drum helix	4" high, 9" pitch
Soak time	1 minute
Soak temperature	170°-180°F
Ventilation	Fan rated at 2380 CFM

PRODUCT ASSURANCE  
OPERATION 4A

CSP Station #3

<u>C/D</u>	<u>Description of Characteristic</u>	<u>Inspection Method</u>
0000	Diameter of center hole	Gage
0000	Diameter of stud holes	Gage
0000	True position of stud holes	Gage
0000	Largest outside diameter	Gage
0000	Profile of outside of cap	Gage
0000	Outside blend radius	Gage
0000	Thickness of top of cap	Gage
0000	Inside profile of cap	Gage
0000	Overall height of cap	Gage
0000	Inside blend radius	Gage
0000	Concentricity of outside profile with center hole	Gage
0000	Chamfer on outside edge	Gage
0000	Perpendicularity of top surface to centerline	Gage
0000	Perpendicularity of bottom surface to centerline	Gage
0000	Flatness of top	Gage
0000	Surface finish	Profilometer
0000	Evidence of poor workmanship	Visual

## OPERATION 30

### Laser Welding Machine

The caps and bodies will be manually loaded into bulk hoppers adjacent to the laser welding machine. Automatic feeders will move the caps and bodies from the hopper to feeder bowls or similar devices for orienting the parts prior to presenting them to the pick and place unit.

Avco has examined various types of special tooling, which could adequately accomplish the task of presenting the cap and body to the laser for welding. Possible choices are intermittent rotary indexers, in-line, walking beam in-line to name a few. For this discussion we have chosen an intermittent rotary indexer of the Gilman type.

- Station 1 Pick and place the body into a nest and probe for presence of part. In addition, the probe will be designed to determine that the body has correct counterbore for accepting the cap.
- Station 2 Idle
- Station 3 Pick and place cap onto the body and simultaneously probe for presence of cap. A central hold down device, capable of securing mechanically the cap to the body, will be actuated at this time.
- Station 4 Idle
- Station 5 Laser weld. Weld area to be shielded by inert gas--helium.
- Station 6 Idle
- Station 7 Cylindrical grinding wheel positioned to clean off any weld flash, outside tolerance specified on drawing, in shoulder area.
- Station 8 Idle
- Station 9 Automatic gaging of 1.80 dimension.
- Station 10 Automatic gaging of cap height--0.490 dimension.

- Station 11 Eject "partial" assemblies (bodies which did not receive caps from pick and place unit) and/or assemblies not meeting dimensions 1.8 or 0.49.
- Station 12 Idle
- Station 13 Eject "good" assemblies onto a conveyor.
- Station 14 Probe empty nest.

Solid state logic will be incorporated into the machine to accomplish the above functions. Included is a memory system which controls the operation assembly sequence.

The sequential memory system is comprised of components which "remember" the status of all previous operations and store this information, regardless of input power loss, at each inspection station. Each inspection station electromechanically senses the Go/No-Go status of a previous operation. The information (Go/No-Go) is then passed to the appropriate memory unit. At each succeeding index in the assembly sequence, the memory "follows" any faulted part and locks out any additional assembly operation. At the proper index point, the memory initiates the reject feature removing the faulted part. The memory system also maintains a fault count. Each inspection station has in addition to the memory a settable counter. If any inspection station registers one or more successive faults, according to its setting, the machine is stopped and a fault indicator is illuminated which allows the operator to quickly locate the problem station.

The laser to be used in welding the cap and body is Avco's HPL transverse-flow device, utilizing the ionizer-sustainer concept. Lasing is initiated by a low power, broad-beam ionizer that irradiates the optical cavity. Then the main or sustainer electrical power is delivered to the conducting gas, resulting in a uniform, controllable discharge.

The HPL has automatic control of output power to within  $\pm 3$  percent of preset values, regardless of ramp-up time or fluctuations in line voltage.

External optics, tailored to specific applications, allow precise focusing of an HPL laser beam in a variety of spot sizes, which lends itself to laser welding, which requires a precisely focused, coherent laser beam. When focused to a spot size on the order of 0.75mm (0.03 in.) dia., HPL lasers produce power densities in excess of 2200 KW/cm<sup>2</sup>. The heat generated melts the metal, rapidly yielding a deep, narrow weld that has high joint efficiency and exhibits minimal distortion.

## OPERATION 90

### Grit Blast, Wash, and Dry

The welded assemblies are deposited on an aligning and dispensing fixture, held horizontally, and rotated through a dry internal and external grit blast operation equipped with automatic dust collectors and abrasive make up units. The internal grit blast deburrs the knurl, cleans the weld penetration, and removes internal weld spatter. The external grit blast cleans and deburrs the welded joint at the cap and body junction. Grit blasted parts are conveyed from the dry grit blast section, turned to a vertical position--open end down before the wash section, and washed to remove all residual dust. The wash section will be equipped with settling tanks, filters, and a fluid recovery system with supplementary washing fluid automatically maintained.

The washed parts continue through a drying oven for complete drying and are deposited on a conveyor.

The equipment planned for this operation can be procured from Dawson and McDonald Co., Wilmington, Massachusetts.

A few of the significant features of the equipment follow:

Capacity	1050 pieces per hour
Blast Cabinet	
Infeed	Vibratory hopper 3 cu. ft. capacity
Part slide	Orient bodies open ends out, two at a time
Indexer	Position oriented parts, two at a time, on belt conveyor
Conveyor size	6" wide x 15' long, steel belt with rotating rubber holders
Holder rotation	60 rpm
Nozzles	4 exterior, 2 interior
Grit	Aluminum oxide 220 mesh
Abrasive make-up	Automatic monitoring and replacement
Dust collector	Cyclone type with particle separation and automatic filter cleaning

Wash Cabinet  
Conveyor size  
Solution heating  
Temperature of wash

18" wide x 62' long  
Electric immersion heaters  
Automatically controlled  
170°-180°F

Ventilation  
Dry-off Unit  
Heating elements

Axial type fan 2380 CFM

Electrically powered.

## OPERATION 100

### Heat Treatment (Austempering)

To attain the specified mechanical properties, the bodies must be placed in a heat treating or hardening furnace.

A continuous heat treating line, capable of handling 1200 pounds per hour, can be obtained from Sunbeam Equipment Corporation, Meadville, Pennsylvania. This equipment includes a radiant tube cast link conveyor austempering furnace, electrically heated salt quench with conveyor, single stage rotary washer, and 2000 cfh endogas generator.

The system is designed to heat the work to 1575<sup>o</sup>F, quench in salt for approximately 15 minutes at 800<sup>o</sup>F for complete transformation, and then convey it through a washing system.

The overall dimensions for this system are approximately 50' long x 8.5' wide. In addition, this system will require a pit for the salt quench which would be approximately 9.5' wide x 15' long x 6' deep.

PRODUCT ASSURANCE  
OPERATION 5

<u>C/D</u>	<u>Description of Characteristic</u>	<u>Inspection Method</u>
07001	Hardness test of body Special test--150 pcs.	Wilson Automatic Hardness equipment
09001	Longitudinal force test Special test--25 pcs.	Tinius-Olsen
10001	Transverse force test Special test--25 pcs.	Tinius-Olsen
11001	Inspection of body for cracks--100%	IMPCO Automatic Ultrasonic

## OPERATION 110

### Phosphating

The bodies are moved through a multistage unit consisting of an alkaline cleaner, hot water rinse, zinc phosphate coating, cold water rinse, a chromic acid conditioning rinse, and blow dry.

Solution concentrations, temperature, and drum speed are automatically controlled. A sensing and replenishing unit to maintain proper solutions and control as required for acceptable parts are integral parts of the machine.

The machine described above can be procured from Metal Wash Machine Corporation, Elizabeth, New Jersey.

Some of the machine specifications are:

Load capacity	6000 pieces per hour
Hot soak - alkaline cleaner	1 min. @ 170-180°F
Hot water rinse	1 min. @ 170-180°F
Hot soak and slush wash zinc phosphate	5 min. @ 140-150°F
Unheated soak and cold water rinse	40 sec. room temp.
Hot soak slush chromic acid rinse	40 sec. @ 170-180°F
Forced hot air blast drying	3 min. @ 200°F
Size of unit	8'3" wide x 8' high x 35' long
Solution heating	Electric
Ventilation	2 exhaust fans rated @ 1210 CFM
Drum	30" dia. with 9" pitch helix

PRODUCT ASSURANCE  
OPERATION 6

<u>C/D</u>	<u>Description of Characteristic</u>	<u>Inspection Method</u>
0000	Preservation process control phosphating	Chemical tests
	a. Alkali contamination	
	b. Acid contamination	
	c. Free acid	
	d. Coating weight	
	e. Film thickness	

PRODUCT ASSURANCE  
OPERATION 7

Receiving Inspection - Stud

<u>C/D</u>	<u>Description of Characteristic</u>	<u>Inspection Method</u>
<u>Major Class</u>		
01001	Inside diameter, max.	Gage
01002	Depth of inside diameter	Gage
01003	Concentricity of inside diameter	Gage
01004	Larger outside diameter, min.	Automatic Gage
<u>Minor Class</u>		
01005	Chamfer on inside diameter improper	Visual
01006	Evidence of poor workmanship	Visual
<u>Unclassified</u>		
0000	Smallest outside diameter	Automatic Gage
0000	Length of largest outside diameter	Automatic Gage
0000	Length of smallest outside diameter	Automatic Gage

## OPERATION 120 AND 122

### Final Assembly

Avco has reviewed the remaining operations required to complete the grenade body and has concluded that a single machine can be designed and fabricated to accomplish installation of studs and painting of M46 bodies

Discussions with several automatic assembly machine designers and builders have reaffirmed Avco's feeling. In fact, proposals for such a machine have been received from Automated Process, Inc., Milwaukee, Wisconsin; Dixon Automatic Tool, Inc., Rockford, Illinois; and Industrial Metal Products Corporation, Lansing, Michigan.

A typical final assembly machine can be envisioned which would perform the following:

- Station 1     At this point in the manufacturing cycle, the bodies will have been phosphate coated, which makes them susceptible to scuffing and/or marring. Therefore, it is planned to feed the bodies manually into the machine. Vibrating in-line feeder tracks or conveyors will transfer the bodies to a pick and place unit for positioning into a nest on the tooling plate.
- Station 2     Probe for presence of part.
- Station 3     Idle
- Station 4     Apply yellow paint to side of cap and shoulder area.
- Station 5     Check presence of paint, using photo-detector.
- Station 6     Idle
- Station 7     Pick and place Stud No. 1 into cap.
- Station 8     Pick and place Stud No. 2 into cap.
- Station 9     Idle

- Station 10 Probe for presence of studs. One or both studs missing would deem parts in this specific nest as reject and will be ejected at Station 15.
- Station 11 Idle
- Station 12 Rivet both studs--using two Taumel (or equivalent) orbital head forming units.
- Station 13 Probe to check .138 max. dimension on riveted stud.
- Station 14 Idle.
- Station 15 Eject rejected parts.
- Station 16 Idle
- Station 17 Eject "good" parts.
- Station 18 Probe empty nest.

The "good" assemblies will be automatically placed on a conveyor for transfer to the final inspection machine, where the body assemblies will be checked for hardness.

PRODUCT ASSURANCE  
OPERATION 6

<u>C/D</u>	<u>Description of Characteristic</u>	<u>Inspection Method</u>
	<u>Major Class</u>	
13001	Pull test of clinch of stud Special test	Tinius-Olsen

PRODUCT ASSURANCE  
OPERATION 9

CSP Station #4

<u>C/D</u>	<u>Description of Characteristic</u>	<u>Inspection Method</u>
	<u>Major Class</u>	
02008	Concentricity of center hole with outside diameter	Gage
02012	Height from shoulder to top of cap	Gage
02013	Material thickness thru closed end	Gage
02014	Flatness of top of cap	Gage
02018	Length from top of cap to third largest inside basic diameter	Gage
02019	Corner fillet at shoulder, max.	Gage
02020	Corner radius at intersection of largest outside diameter with face of open end, max.	Gage
02021	Length to larger outside basic diameter on tapered sides of cap	Gage
02022	Length to smaller outside basic diameter on tapered side of cap	Gage
02023	Length from top of cap to smaller inside basic diameter	Gage
02024	Concentricity of tapered outer side of cap with outside diameter	Gage
02025	Minimum thickness through tapered wall of cap at indicated length from top of cap	Gage
02026	Minimum thickness through shoulder area at indicated length from open end	Gage

PRODUCT ASSURANCE  
OPERATION 9 (continued)

<u>C/D</u>	<u>Description of Characteristic</u>	<u>Inspection Method</u>
02027	Diameter of shoulder, min.	Gage
02028	Distance from top of shoulder to end of corner break, max.	Gage
02029	Inside diameter bottom of cavity beyond noted depth, min.	Gage
02030	Chamfer on inside end of center hole missing or improper	Visual
03001	Largest outside diameter, max.	Gage
03002	Height of studs	Gage
03003	Outside diameter of stud, max.	Gage
03004	True position of studs	Gage
03005	Diameter of center hole	Gage
03006	Length to inside end of crimp of stud	Gage
03007	Inside configuration inconsistent with protective finish requirements	Visual
03008	Stud loose, missing, or damaged	Visual-Manual
03009	Bulge or gap at junction of stud with top of cap	Visual
14001	Verification of heat treatment of body assembly--100%	Wilson Automatic Eddy Current or Wilson Automatic Hardness Equipment

PRODUCT ASSURANCE  
OPERATION 9 (continued)

<u>C/D</u>	<u>Description of Characteristic</u>	<u>Inspection Method</u>
	<u>Minor Class</u>	
02031	Third largest inside diameter, max.	Gage
02032	Blend radius of top of cap with sides of cap improper	Gage
03010	Evidence of poor workmanship	Visual

PRODUCT ASSURANCE  
OPERATION 10

Receiving Inspection - Packaging Material

1. Dimensional Inspection.
2. Visual inspection for damage and identification.
3. Review vendor data for compliance with applicable specifications.

## OPERATION 130

### Pack and Palletize

Prior to packing each grenade body will be checked for hardness in accordance with the design requirements.

Bodies, which have been deemed "good" in the hardness checking machine, will be placed onto a track and transferred to a bench, where an operator will manually load the bodies into the cells of the "egg crate" separator in the inner box. When all 100 cells are loaded, a fiberboard separator will be placed atop the first layer and a second "egg crate" separator placed into the inner box. The above process is repeated until a total of 200 grenade bodies are loaded into the inner box.

The inner box shall be sealed using gummed tape, and a pre-printed label shall be applied in accordance with the requirements of drawing 9206167.

The sealed inner box is then placed into a barrier bag, which is evacuated by use of an aspirator. When the bag has conformed to the shape of the inner box, it will be sealed using a heated roller machine.

After the barrier bag has been sealed, the package is then placed into the outer box, which is then sealed with gummed tape and marked in accordance with drawing 9206166.

The boxes are then moved along a conveyor to the storage area, awaiting shipment.

PRODUCT ASSURANCE  
OPERATION 11

CSP Station #5

<u>C/D</u>	<u>Description of Characteristic</u>	<u>Inspection Method</u>
	INNER BOX (UNSEALED)	
	<u>Major Class</u>	
04001	Box damaged, contents exposed	Visual
	<u>Minor Class</u>	
04002	Contents loose	Manual
04003	Marking misleading or unidentifiable	Visual
04004	Label missing or badly wrinkled	Visual
	INNER BOX (SEALED)	
	<u>Major Class</u>	
05001	Barrier bag waterproofness destroyed, separation of heat seal, torn, or punctured	Visual
	<u>Minor Class</u>	
05002	Marking misleading or unidentifiable	Visual
	OUTER BOX (SEALED)	
	<u>Major Class</u>	
06001	Box damaged, contents exposed	Visual
	<u>Minor Class</u>	
06002	Contents loose	Manual
06003	Marking misleading or unidentifiable	Visual
06004	Label missing or badly wrinkled	Visual

PRODUCTION EQUIPMENT

<u>Operation</u>	<u>Description</u>	<u>Equipment Manufacturer</u>	<u>Gross/ Hour/ Machine</u>	<u>Qty Machs. Req'd</u>	<u>Budgetary Total Cost Estimate</u>
10	Machine Body	National-Acme Cleveland OH	553	7	\$1,500,000
20	Spiral Drum Washer	Mannor Machine Crystal Lake IL	2500	2	10,000
40	Emboss Strip Stock M42 Only	Fenn Manufacturing Co. Newington CT	50 1/min. 18,000	1	236,000
50	Blank Cap Mat'l	Henry & Wright Cleveland OH	9000	1	100,000
60	Anneal Cap Blanks M42 Only	Sunbeam Corp. Meadville PA		1	77,000
70	Form Caps	Waterbury Farrel Cheshire CT	2400	2	700,000
80	Spiral Drum Washer	Mannor Machine Crystal Lake IL	2500	2	10,000
30	Laser Welder	Avco Everett Everett MA	3240	2	1,200,000
90	Grit Blast, Wash & Dry	Dawson MacDonald Wilmington MA	1050	3	315,000

TABLE 4

M42/M46 GRENADE BODY PRODUCTION EQUIPMENT

<u>Operation</u>	<u>Description</u>	<u>Equipment Manufacturer</u>	<u>Gross/ Hour/ Machine</u>	<u>Qty. Machs. Req'd</u>	<u>Budgetary Total Cost Estimate</u>
100	Heat Treat	Sunbeam Corp. Meadville PA		1	290,000
110	Protective Finish (Phosphating)	Metal Wash Mach. Corp. Elizabeth NJ	6000	1	70,000
120 & 122	Install Studs and Paint (M46 only)	Special Rotary Indexer	3000	2	250,000
130	Package and Ship				5,000
	Conveyors, Monorails, Miscellaneous Mat'l Handling Equipment				100,000

TABLE 4 (continued)

M42/M46 GRENADE BODY PRODUCTION EQUIPMENT

PRODUCT ASSURANCE EQUIPMENT

<u>Operation</u>	<u>Equipment</u>	<u>Gross Rate per Equipment</u>	<u>Quantity Equipment Required</u>	<u>Budgetary Total Cost Estimate</u>
Hardness Check	Wilson Automatic Hardness Equipment	1200/hr.	1	\$14,325.
Longitudinal and Trans- verse Force Tests	Tinius-Olsen	60/hr.	1	33,000.
100% Ultrasonic Inspec- tion for Cracks	Impco Automatic	5000/hr.	2	403,740.
Dimensionally Inspect Studs	Dorsey Gage	3600/hr.	1	25,000.
100% Verification of Heat Treat	Wilson Automatic Eddy Current or Wilson Automatic Indent Hardness Equipment	6000/hr  3600/hr.	1  2	23,500.  66,000.

TABLE 5

M42/M46 GRENADE BODY

## SECTION V

### SCRAP ANALYSIS

#### A. Body

Tubing, seamless, SAE 4140, cold drawn, aircraft quality, low alloy steel, per AMS 6381.

Tube dimensions--O. D. 1.515 x .140 wall

2" length to be used for each body = 1.1066 in<sup>3</sup>

Bore I. D. = .0822 in<sup>3</sup>

Bore Cap C'Bore = .0073

Bore 1.315 x .791 + 30° x .045 = .0936

Groove = .0029

Bore 1.341 x .530 + 45° x .013 = .0323

Cutoff = .0147

Body--Total Scrap = .2984 in<sup>3</sup>

1.0 in<sup>3</sup> steel = .283 lbs.

Tubing Stock .283 x 1.1060 = .3131 lbs.

Scrap .283 x .2984 = .0844 lbs.

B. Cap

Material--Cold rolled strip AISI 4140 electric furnace ASTM A-507 vacuum degassed 90% min. spheroids Rockwell B85 max. Number 2 finish.

Strip 6.5" wide .112" thick blanking three wide in hexagonal pattern.

.1514 lbs raw material/blank  
.0995 lbs steel/blank  
.00196 lbs--3 pierced holes

.1514-.0995 = .0519 scrap/blank  
.0519+.00196 = .0538 lbs. total scrap per cap

C. Total Scrap per Grenade Body

.0844 + .0538 = .1382 lbs. scrap per grenade body

AD-A047070

SECTION VI

COST ANALYSIS

Attach the following four sheets adjacent to page 75, Section VI, Cost Analysis, of Avco Report AVSD-0018-77-RR, Production Engineering Effort on M42/M46 Grenade Bodies, dated 15 November 1977.

C. Total Scrap per Grenade Body

$$.0659 + .0538 = .1187 \text{ lbs. scrap per grenade body}$$

*Page 74*

Tube dimensions--O. D. 1.515 x .140 wall

$$1.830'' \text{ length to be used for each body} = 1.1066 \text{ in}^3$$

$$\text{Bore I. D.} = .0822 \text{ in}^3$$

$$\text{Bore Cap C'Bore} = .0073$$

$$\text{Bore } 1.315 \times .791 + 30^\circ \times .045 = .0936$$

$$\text{Groove} = .0029$$

$$\text{Bore } 1.341 \times .530 + 45^\circ \times .013 = .0323$$

$$\text{Cutoff} = \underline{.0147}$$

$$\text{Body--Total Scrap} = .2330 \text{ in}^3$$

$$1.0 \text{ in}^3 \text{ steel} = .283 \text{ lbs.}$$

$$\text{Tubing Stock } .283 \times 1.1066 = .3131 \text{ lbs.}$$

$$\text{Scrap } .283 \times .2330 = .0659 \text{ lbs.}$$

*Page 73*

Total Labor/Month	<u>\$341,561</u>	=	.244/Unit
Grenade Bodies/Month	1,400,000		

\* \* \* \* \*

Material

Body

Tubing 1.93/foot 1.830 inches/body assembly	=	.2905
--	---	-------

Cap

Sheet .485/lb. .154# Raw Material/Cap	=	<u>.0748</u>
--	---	--------------

Subtotal	.3653
----------	-------

G&A (27%)	<u>.0986</u>
-----------	--------------

Total Material Cost	<u><u>.4639</u></u>
---------------------	---------------------

\* \* \* \* \*

Cost Summary

Labor	.2440
-------	-------

Material	<u>.4639</u>
----------	--------------

.7079

Fee 7.5%	<u>.053</u>
----------	-------------

Unit Price	<u><u>.7609</u></u>
------------	---------------------

M42/M46 Grenade Body

Estimated labor costs to produce 1,400,000 parts per month on a 3-8-5 basis, which equals 501 hours.

Direct Labor

		<u>Hrs.</u>	<u>Rates</u>	<u>D/L \$</u>	
Manufacturing	\$77,329	See Sheet No. 3			
Product Assurance	28,577	See Sheet No. 4			
Design Engineer	1,187	126	9.42	1,186.92	
Financial Control	173	18	9.63	173.34	
Contracts	214	18 Adm. 9 Sec'y	9.63 4.52	173.34 40.68	214.02
Project Office	1,662	78 Mgr. 41 Sec'y	18.94 4.52	1,477.32 185.32	1662.64
	<u>\$109,142</u>				
Super Lab (11%)	<u>12,005</u>				
Total Direct Labor	121,147				
Overhead (86%)	104,186				
Fringe (36%)	<u>43,613</u>				
Subtotal	268,946				
G&A (27%)	<u>72,615</u>				
Total Cost	<u>\$341,561</u>				

Manufacturing

	<u>No. People per Shift</u>	<u>Total Hours per Day</u>	<u>Rate</u>	<u>D/L \$ per Day</u>
Manufacturing Engineer	2	48	9.63	462.24
Production Control	1	24	10.40	249.60
Material Handling	3	72	3.73	268.56
Rolling Mill	1	24	6.35	152.40
Blanking Press	1	24	6.35	152.40
Cap Annealing	1	24	3.73	89.52
Cap Press	2	48	6.35	304.80
Cap Degrease	1	24	3.73	89.52
Bar Machines	4	96	6.35	609.60
Body Degrease	1	24	3.73	89.52
Laser Welders	2	48	6.35	304.80
Cleaning, Grit blast	1	24	3.73	89.52
Heat Treat	1	24	3.73	89.52
Phosphating	1	24	3.73	89.52
Stud Install & Painting	2	48	6.35	304.80
Off Loading & Boxing	2	48	3.73	179.04
Facking	2	<u>48</u>	3.73	<u>179.04</u>
		672		3,704.40
				÷ 24
				154.35
				<u>x 501</u>
				77,329.35

Product Assurance

	<u>No. People</u>	<u>Total Hours per Day</u>	<u>Rate</u>	<u>D/L \$ per Day</u>
P. A. Engineer	1	8	12.94	103.52
Quality Process Engineer	1	8	10.40	83.20
Tool & Gage Engineer	1/2	4	7.78	31.12
Procurement Planner	1/4	2	7.78	15.56
Vendor Liaison	1/4	2	7.78	15.56
Tool & Gage Calibration	1/4	2	6.35	12.70
Material Drop Area & MRB Clerk	1/2	4	7.54	30.16
In Process MRB & Lot Control	1/2	4	7.54	30.16
Statistical Analysis	1/2	4	15.37	61.48
1st Shift Supervisor	1	8	10.40	83.20
1st Shift In Process Inspect.	8	64	48 @ 3.73 16 @ 6.35	179.04 101.60
1st Shift Receiving Inspect.	1	8	7.54	60.32
2nd Shift In Process Inspect.	8	64	48 @ 3.73 16 @ 6.35	179.04 101.60
3rd Shift In Process Inspect.	8	64	48 @ 3.73 16 @ 6.35	179.04 <u>101.60</u>
		246		1,368.90
				+ 24
				57.04
				<u>x 501</u>
				28,577.04

## SECTION VI

### COST ANALYSIS

The cost analysis presented addresses only recurring costs taken at an assumed point in time when all facilities have been installed, machines have been tuned and debugged, and personnel trained.

Labor is based on 1978 projected rates, and material is based on 1977 rates.

The projected cost of the M42/M46 grenade body assemblies manufactured by the techniques described in this report is 76 cents.

ADDENDUM 1

PRODUCT ASSURANCE OPERATION SHEETS

PRODUCT ASSURANCE OPERATION SHEET

DATA MUST BE FILED

INSTRUCTION ONLY

SERIAL NO.

SHEET OF

DWG. NO./PART NO.

M42/245

REV.

PART NAME

Body Assembly

P.O./M.O./S.M.O.

291138

PLANNER

Morrisette

DATE

L. DWG.  
 UNREL. DWG.

ENG. CHANGES VERIFIED

OPER. NO.

OPERATION DESCRIPTION

1.0 Review vendors certification for compliance with MIL-E-6875.

2.0 Perform a hardness test as follows:

a. Set up hardness tester for Rockwell A scale. 60 kg & "brale" penetrator. Calibrate with proper test block.

b. Using a V-block anvil, check hardness in 3 places approximately 120 degrees apart, 3/8" from open end.

c. Record range of hardness values.

d. Hardness should be as follows:

EX24131== Rockwell A 74-76 (smooth interior)

EX 23869-- Rockwell A 71-73 (knurled interior)

Hardness range= EX24131 71-73 EX23869 74-75

PRODUCT ASSURANCE OPERATION SHEET

DATA MUST BE FILED

INSTRUCTION ONLY

SERIAL NO.

SHEET OF

DWG. NO./PART NO.

REV.

PART NAME

P.O./M.O./S.M.O.

PLANNER

EX23751

A

CAP

Morrisette

DWG.  
 UNREL. DWG.

~~XXXXXXXXXXXX~~

32 pc. sample -- accept 1 -- reject 2

DATE

OPER. NO.	OPERATION DESCRIPTION						
1.0	Dimensionally inspect per drawing and record results.						
	Requirement						Actual (RANGE)
	.209-.212 dia.						.210
	.375 bsc. 2 ples.						.375
	0 A .005 dia.						.002-.003
	.125-.127 dia.						.1255
	1.245 dia. bsc.						1.245
	.160-.217						basic diameter w/in
	1.282-dia. bsc.						1.282
	.398-.418						basic diameter w/in
	A .005						.001-.003
	.587-.593						.589-.591
	A .002 2' ples.						.0002
	.002						.0002-.0012
	.190 R.						.187
	1.289-1.291 dia.						1.290-1.291
	.005-.010 X 40-50						.007 X 45
	.005 R max. 2 ples.						.003
	.098-.115						.099-.110
	.145						basic diameter w/in
	1.000 dia. bsc.						1.000
	.528-.549						basic diameter w/in
	1.181 dia. bsc.						1.181
	.03-.060 R.						.032
	63						78 OK





PRODUCT ASSURANCE OPERATION SHEET

DATA MUST BE FILED

INSTRUCTION ONLY

SERIAL NO.

SHEET OF

DWG. NO./PART NO. <b>EX24131</b>	REV. <b>A</b>	PART NAME <b>Body Machining Semi-Finished</b>	P.O./M.O./SNO.	PLANNER <b>Morrisette</b>
<input type="checkbox"/> .. DWG. <input type="checkbox"/> UNREL. DWG.	ENG. CHANGES VERIFIED			DATE

OPER. NO.	OPERATION DESCRIPTION	
<b>1.0</b>	The following features are classified as majors and shall be inspected to a .40 AQL -- <sup>50</sup> / <sub>50</sub> pc. sample -- accept 0 -- reject 1	
	Requirement	Actual (range)
	1.514-1.516 dia.	1.514-1.516
	1.335-1.347 dia.	1.336-1.339
	A .005 dia.	.0015-.0015
	1.310-1.320 dia.	1.312-1.314
	A .000 dia.	.002-.004
	1.292-1.294 dia. (process tolerance)	1.294-1.296
	A .000 dia.	.000-.002
	.525-.535	basic diameter w/in
	.800-.810	basic diameter w/in
<b>2.0</b>	The following features are classified incidental and shall be inspected to a 1.5 AQL -- 50 pc. sample -- accept 1 -- reject 2.	
	Requirement	Actual (range)
	.103-.107	.103-.107
	EA .005	.0005
	LA .002	.0004
	1.255-1.260 dia.	1.256-1.257
	⊙ A .000 dia. ⊙	.0012
	1.800-1.792	1.792-1.799
	LA .005	.0015
<b>C</b>	.010 max. X 45 typ.	.005 X 45
	1.2985 dia bsc.	1.2985
	1.3260 dia. bsc.	81 1.3260



PRODUCT ASSURANCE OPERATION SHEET

DATA MUST BE FILED  
 INSTRUCTION ONLY

SERIAL NO.  
SHEET OF  
PLANNER  
Morrissette  
DATE

DWG. NO./PART NO. **EX-23869** REV. **A** PART NAME **Body Machining Semi-Finished** P.O./M.O./SMO.

DWG.  ENG. CHANGES VERIFIED  
 REL. DWG.

OPER. NO.	OPERATION DESCRIPTION			
1.0	The following features are classified as majors and shall be inspected to a .40 AQL -- <sup>50</sup> pc. sample -- accept 0 -- reject 1			
	Requirement			Actual (range)
	1.514-1.516 dia. (process tolerance)			1.509-1.517 (IR #22248)
	1.335-1.347 dia.			1.337-1.346
	A .000 dia.			.0004
	1.310-1.320 dia.			1.311-1.315
	A .000 dia.			.0004
	1.292-1.294 dia.			1.2945-1.2952
	A .000 dia.			.0004
	.525-.535			Basic dia. falls w/in
	.800-.810			basic dia. falls w/in
2.0	The following features are classified incidental and shall be inspected to a 1.5 AQL -- 50 pc. sample -- accept 1 -- reject 2.			
	Requirement			Actual (range)
	.103-.107			.097-.114 (IR #22248)
	LA .005			.0018
	LA .002			.0002
	1.255-1.260 dia.			1.253-1.2604 (IR #22248)
	⊙ A .000 dia. ⊙			.0004
	1.800-1.792			1.792-1.800
	LA .005			.0015
	.010 max. X 45 typ.			.008 X 45
	1.2985 dia bsc.			1.2985
	1.3260 dia. bsc.			1.3260



## ADDENDUM 2

### INTERNAL KNURLING TOOL

The tool consists of a tool steel bar approximately 1 inch in diameter and 12 inches long. A slot is cut .100 inches wide by 4.0 inches long, across the diameter of the bar, making two separate segments of the solid bar for a 4.5 inch distance. Two knurls approximately .625 inch diameter are mounted on carbide pins, one in each segment of the bar located 90 degrees from the slot. Each segment of the bar has a pocket to receive each knurl. The location of the knurl pins establishes the location of each of the knurls and positions them to protrude beyond the outside diameter of the 1.0 inch bar. The distance across the two knurls is adjustable (by spreading the segments) to produce the correct tracking and the exact number of teeth on the work. When this minor adjustment is made on the tool to produce perfect tracking at the depth of knurl penetration, no additional adjustment is required. When inserted into the finish bore of the grenade while the body is turning, a perfect internal knurl will be produced.

#### Knurls and Knurl Pins

The knurls are made from T15 high cobalt alloy steel, ground and lapped to a smooth hard finish, and are mounted on ground carbide pins. The knurls are mounted in the tool holder using one right hand and one left hand diagonal knurl. This combination produces a diamond pattern of .088 by .088 on the work, resulting in a 2 grain fragment size.

The estimated life of the knurling tool holder is several million pieces.

The estimated life of the knurls and pins is 31,000 pieces.

#### Knurling Tools

Knurling Tool Holder in lots of 10 each	\$120. each
Knurls T15 Hi-Cobalt in sets of 100	8. set
Knurl Pins Carbide--2 each req. set	8. set

SECTION VII

DISTRIBUTION

<u>Recipient</u>	<u>Copies</u>
Commander U. S. Army Armament Research and Development Center Dover, New Jersey 07801 Attn: Large Caliber Weapons System Lab, Sub-Munitions Section DRDAR-LCU-DS	2
Attn: Product Assurance Directorate DRDAR-QAR-1	2
Attn: Scientific & Technical Information Division DRDAR-TSS	5
Attn: Comptroller DRDAR-CPF	2
Attn: Tech. Data/Configuration Management Division DRDAR-TST	2
Commander U. S. Army Materiel Development & Readiness Command 5001 Eisenhower Avenue Alexandria, Virginia 22333 Attn: DRCD-WC	1
Project Manager for Selected Ammunition U. S. Army Materiel Development & Readiness Command Dover, New Jersey 07801 Attn: DRCPM-SA	1
Project Manager for Base Modernization U. S. Army Materiel Development & Readiness Command Dover, New Jersey 07801 Attn: DRCPM-PB-M	1

Defense Documentation Center  
Cameron Station  
Alexandria, Virginia 22314

12

Defense Contract Administration Services  
666 Summer Street  
Boston, Massachusetts 02210  
Attn: DCRB-GBCB-B5

2