

AD-A047 189

MISSOURI UNIV-ROLLA
PENNING IONIZATION; MEASUREMENT OF ION AND MOLECULAR LIFETIMES. (U)
DEC 77 L D SCHEARER, W F PARKS

F/G 20/10

N00014-75-C-0477

UNCLASSIFIED

NL

1 of 1
AD A047189



47189

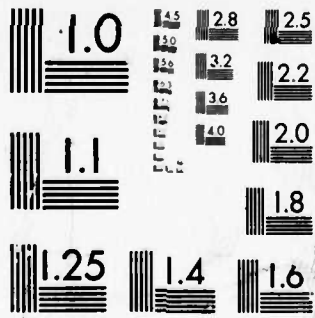

MICROCOPY RESOLUTION TEST CHART
NATIONAL BUREAU OF STANDARDS-1963-A

ADA047189

PENNING IONIZATION: MEASUREMENT OF ION AND MOLECULAR LIFETIMES

L. D. Schearer
W. F. Parks
University of Missouri-Rolla

DDC
RECEIVED
DEC 5 1977
RECEIVED
F

Annual Report to the Office of Naval Research
Grant No. N00014-75-C-0477 for the period Dec. 1976 to Dec. 1977.

DISTRIBUTION STATEMENT A
Approved for public release;
Distribution Unlimited

(9) Rept. no. 11 (Annual), 1 Dec 76-1 Dec

SECURITY CLASSIFICATION OF THIS PAGE (When Data Entered)

REPORT DOCUMENTATION PAGE		READ INSTRUCTIONS BEFORE COMPLETING FORM
1. REPORT NUMBER 11	2. GOVT ACCESSION NO.	3. RECIPIENT'S CATALOG NUMBER
4. TITLE (and Subtitle) (6) Penning Ionization: Measurement of Ion and Molecular Lifetimes,		5. TYPE OF REPORT & PERIOD COVERED Annual; Dec. 1, 1976 to Dec. 1, 1977
7. AUTHOR(s) (10) L. D. / Schearer & W. F. / Parks		6. PERFORMING ORG. REPORT NUMBER
9. PERFORMING ORGANIZATION NAME AND ADDRESS The Curators of the University of Missouri- Rolla, MO 65401		8. CONTRACT OR GRANT NUMBER(s) (15) NO 0014-75-C-0477
11. CONTROLLING OFFICE NAME AND ADDRESS Department of the Navy, Office of Naval Research Washington, D.C. 20360		10. PROGRAM ELEMENT, PROJECT, TASK AREA & WORK UNIT NUMBERS NR 343-011
14. MONITORING AGENCY NAME & ADDRESS (if different from Controlling Office)		12. REPORT DATE (11) 1 Dec 1977
		13. NUMBER OF PAGES (12) 57p.
		18. SECURITY CLASS. (of this report) UNCLASSIFIED
		15a. DECLASSIFICATION/DOWNGRADING SCHEDULE
15. DISTRIBUTION STATEMENT (of this Report) Approved for public release: distribution unlimited.		
17. DISTRIBUTION STATEMENT (of the abstract entered in Block 20, if different from Report)		
16. SUPPLEMENTARY NOTES		
19. KEY WORDS (Continue on reverse side if necessary and identify by block number) Penning ionization, Coherence, dye lasers, He Beams, 1st kind collisions.		
20. ABSTRACT (Continue on reverse side if necessary and identify by block number) "Intense Flowing Hollow-Cathode Lamp", F.H.K. Rambow and L.D. Schearer, Rev. Sci. Instru 48, 92 (1977). "Radiative Lifetime of the A ² State of CH", James Carozza and Richard Anderson, J. Opt. Soc. Am. 67, 118 (1977). "Spin & Coherence Transfer in Penning Ionization", L.D. Schearer and W.F. Parks in Progress in Atomic Spectroscopy, ed. by H. Kleinpoppen and W. Hanle. (Plenum Press) to be published Spring 1978.		

DD FORM 1473 1 JAN 73

EDITION OF 1 NOV 65 IS OBSOLETE
S/N 0102-LF-014-6601

SECURITY CLASSIFICATION OF THIS PAGE (When Data Entered)

400144

Jones

"A High Flux Beam Source of Fast Neutral Helium Atoms", D.W. Fahey and L.D. Schearer. Submitted to Rev. Sci. Instr.

"A Xenon-ion Laser Pumped Blue Dye laser", D.W. Fahey and L.D. Schearer. Submitted to IEEE. J. Quant. Elec.

"Polarization of the $1P_1$ Resonance Levels of Group II Atoms in Collision with 1 keV Helium Atoms", D.W. Fahey and L.D. Schearer. Submitted to Phys. Letters.

TABLE OF CONTENTS:

1. Intense Flowing Hollow-Cathode Lamp; F.H.K. Rambow and L.D. Schearer, Rev. Sci. Instru. 48, 92 (1977).
2. Radiative Lifetime of the $A^2\Delta$ State of CH^+ ; James Carroza and Richard Anderson, J. Opt. Soc. Am. 67, 118 (1977). ^{(2) delta}
3. Spin Coherence Transfer in Penning Ionization; L.D. Schearer and W.F. Parks in Progress in Atomic Spectroscopy, ed. by H. Kleinpoppen and W. Hanle. (Plenum Press) to be published Spring 1978.
4. A High Flux Beam Source of Fast Neutral Helium Atoms; D.W. Fahey and L.D. Schearer. Submitted to Rev. Sci. Instr.
5. A Xenon-ion Laser Pumped Blue Dye Laser; D.W. Fahey and L.D. Schearer. Submitted to IEEE. J. Quant. Elec.
6. Polarization of the $1P_1$ Resonance Levels of Group II Atoms in Collision with 1 keV Helium Atoms; D.W. Fahey and L.D. Schearer. Submitted to Phys. Letters.
7. Investigation of Volume Recombination Kinetics in an Alkali-Noble Gas Afterglow of a High Power, Fast Laser Pulse.

(1) P(1)

ADDRESS FOR	White Section <input checked="" type="checkbox"/>
	Buff Section <input type="checkbox"/>
ANNOUNCED	<input type="checkbox"/>
CLASSIFICATION	
BY	
DISTRIBUTION/AVAILABILITY CODES	
DI	SPECIAL
A	

i

Intense flowing hollow cathode lamp*

F. H. K. Rambow and L. D. Scheerer

Department of Physics, University of Missouri-Rolla, Rolla, Missouri 65401

(Received 9 April 1976; in final form, 30 August 1976)

An inexpensive, simple, and versatile hollow cathode lamp has been developed which produces intense ion resonance radiation of about 1 mW into $4\pi/25$ sr. The lamp employs flowing helium gas to sustain the discharge. The construction permits a variety of cathode seed materials to be easily interchanged. The same lamp has been used as a source of ion resonance radiation for Ca, Ba, Zn, Mg, Sr, Yb, and Eu.

We have succeeded in developing a flowing hollow cathode lamp with which we have measured radiative lifetimes of some Group II and rare earth ion levels.^{1,2} The lamp is very simple and inexpensive to build. Since it operates on dc there are no problems of rf shielding. With reasonable care in construction and operation it is practically indestructible. Unlike sealed hollow cathode lamps the same lamp can be used for many elements and can be readily disassembled for cleaning and recharging. Welding grade helium is used as the flowing buffer gas because it is readily available and reasonably inexpensive. The use of flowing helium gas inhibits the condensation of material on the lamp windows and circumvents the necessity for high vacuum techniques in the preparation of the lamp.

A drawing of the lamp is shown in Fig. 1. The lamp is both air and water cooled for stability and long life. The anode is machined from a 3.81-cm brass cylinder. Water cooling is provided by a 4.8-mm-diam copper tube soldered around the anode. The inlet He stream flows across the quartz window on the front of the anode to prevent fogging by metal vapor deposits. The anode is supported by the outer jacket, a 2.54-cm-diam Pyrex tube 12.7 cm long. This tube is cooled by a stream of air. The window and Pyrex tube are attached to the anode by Dow Corning silicon rubber compound. The cathode is machined from a 9.8-mm rod of boron nitride and lined with 0.1-mm tantalum foil. It is supported by a stainless steel welding rod insulated by a small diameter Pyrex tube. The welding rod is attached to a 6.35-mm brass rod that extends out through an Ultra-Torr³ fitting so that the anode-cathode spacing can be adjusted while the lamp is in operation. The entire cathode assembly is mounted to the glass jacket by an O-ring connector similar to the Ultra-Torr commercial fittings. This allows the cathode to be pulled out easily for recharging.

The lamp normally operates at 3 A with a helium pressure in the range 1–50 Torr. A flow rate on the order of 1×10^3 atm $\text{cm}^3 \text{min}^{-1}$ is maintained. The power into a solid angle of $4\pi/25$ sr from the 4078 Å sr line was found to be 1×10^{-3} W or about 2×10^{15} quanta sec^{-1} . Compared to previous lamp designs the flowing hollow cathode lamp described here provides excellent versatility and ease of construction without sacrificing intensity.⁴ The lamp described by Weber⁵ has greater

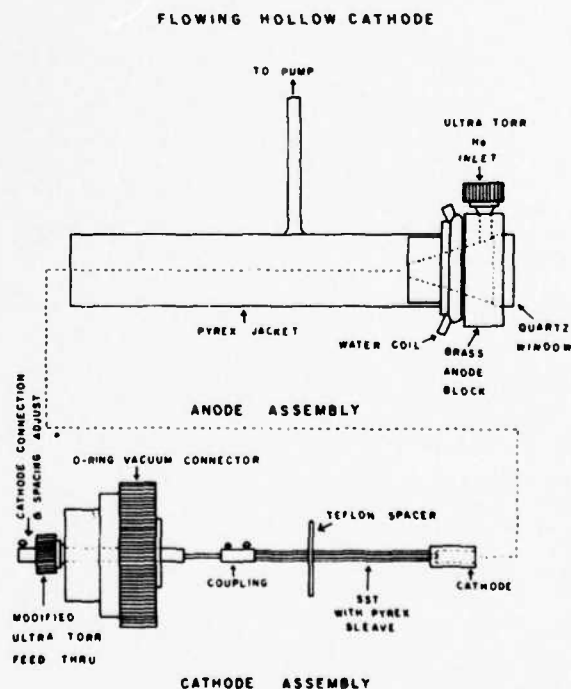

FIG. 1. Flowing hollow cathode lamp. Air is blown over the Pyrex jacket near the discharge region.

intensity (10^{16} quanta sec^{-1} into $4\pi/25$ sr); however, the current required to obtain this output is 30–40 A.

Our design, in addition to high intensity, allows a wide range of materials to be used in the cathode, and furthermore this material can be changed in minutes. The lamp can be opened to air, the cathode assembly pulled out, cleaned in nitric acid, reinserted, and run to bake out water vapor, pulled out and charged with a new material, and be running, all within five minutes. We

have used this source with Ca, Sr, Mg, Ba, Zn, Cd, Yb, and Eu.

* Research supported by the Office of Naval Research under Contract No. ONR-N00014-69-A-0141-0004.

¹ F. H. K. Rambow and L. D. Scheerer, *Bull. Am. Phys. Soc.* **20**, 1448 (1975).

² F. H. K. Rambow and L. D. Scheerer, *Phys. Rev. A* **14**, 738 (1976).

³ Ultra Torr is a trade name of Cajon Co., Cleveland, OH.

⁴ B. Budick, R. Novick, and A. Lurio, *Appl. Opt.* **4**, 229 (1965).

⁵ E. W. Webber, *Z. Phys.* **256**, 1 (1972).

Radiative lifetime of the $A^2\Delta$ state of CH^\dagger

James Carozza and Richard Anderson

Department of Physics, University of Missouri-Rolla, Rolla, Missouri 65401

(Received 3 September 1976)

The lifetime of various rotational levels of the $v' = 0$ and 1 vibrational states of the $A^2\Delta$ state of CH are reported. The lifetimes for the various levels were nearly constant with the rotational quantum number N' . For the $v' = 0$ level it was 508 ± 25 ns and for the $v' = 1$ level, it was 514 ± 33 ns. The bandhead lifetime was 500 ns and these lifetimes are very close to the bandhead lifetime.

The present investigation was begun because of the unusual results reported by Anderson *et al.*¹ They reported irregular variations of lifetime over the band corresponding to the $A^2\Delta-X^2\Sigma$ transition in CH . They made measurements at various positions in the band with a low resolution monochromator and could not resolve individual rotational transitions. They excited the CH radical with a pulsed rf discharge which was terminated in 15 ns, but the decay curves were recorded on a boxcar integrator and X-Y recorder. As a result, they could not measure weak CH emissions. Since there is a many-line H_2 spectrum in this region, the possibility of overlap of CH and H_2 lines could not be ruled out.

In the present study the same pulsed rf discharge was employed, but the spectral lines were resolved on 3/4 m Spex monochromator with a 0.1 Å resolution, and weaker signals could be observed since the delayed coincidence detection technique was used. Now the rotational lines of the $A^2\Delta-X^2\Sigma$ transition were resolved from the heavily quenched H_2 lines. A similar effect was noted in our measurements of the lifetime of the rotational levels of the $B^2\Sigma^-$ state.² This overlap of the CH and H_2 spectra at low CH pressures made it difficult to measure the CH lifetimes accurately at very low pressures.

Erman³ has measured the lifetime of rotational levels of the vibrational $v' = 0$ and 1 levels for the $A^2\Delta$ state by the high-frequency deflection method in which an electron beam is rapidly terminated by high-frequency deflection of it past a slit. He could resolve Λ doubling components. The lifetimes for both Λ doubling components of the rotational states $N' = 6$ to 23 for the vibrational level $v' = 0$ were nearly constant and both had the same value of 534 ± 5 ns. However, a different behavior was observed for the lifetime of the rotational levels of the $v' = 1$ state. In this case the lifetime for both Λ doubling components decreased continuously for $N' > 11$ between 11 and 16. The lifetime of the "d" component reached an almost constant value of 365 ns for $N' \geq 16$, while the "c" component passed through a minimum of 354 ns at $N' = 18$ and increased again to 368 ns at $N' = 20$. The $N' = 11$ level coincides with the dissociation limit of the $X^2\Sigma$ ground state and he interpreted this behavior as an unobserved predissociation of the CH A state by the overlap of the vibrational wave functions of the $A^2\Delta$ state with the continuum wave function of the $X^2\Sigma$ ground state. A spin-orbit and rotational-electronic coupling leads to a predissociation of this type.⁴

In our study the Λ doubling components could not be

resolved. We observed a nearly constant lifetime of the rotational levels of the $v' = 0$ state for $N' = 6$ to 20. This result agreed with those observed by Erman, except our constant value was approximately 508 ± 25 ns. This was very close to the bandhead lifetime of the system which is 500 ns. From our limited measurements of the rotational levels for the $v' = 1$ vibrational state there may not be a drop in lifetime. From our limited measurements the lifetime was 514 ± 33 ns, which is similar to the value obtained for the rotational states of the $v' = 0$ levels. The data are displayed in Fig. 1.

The difference between our data and those of Erman³ may be caused by the erroneous removal of the lifetime of the H_2 lines from the data, which will tend to produce a complex decay. The H_2 molecular emission has a zero pressure lifetime near 100 ns. Further, any nitrogen impurity could cause an error in lifetime measurements. The first negative system of N_2^+ has an intense, extended band system starting at 4278 Å and extending to 4130 Å. The N_2^+ first negative zero pressure lifetime is 65 ns. This experiment should be repeated by some other investigators with a different technique, for its results may explain the formation of CH in interstellar space. If a predissociation of the $v' = 1$ level of the $A^2\Delta$ state by the $X^2\Sigma$ state is possible, this is a possible inverse mechanism for the formation of the CH molecule observed in interstellar space.

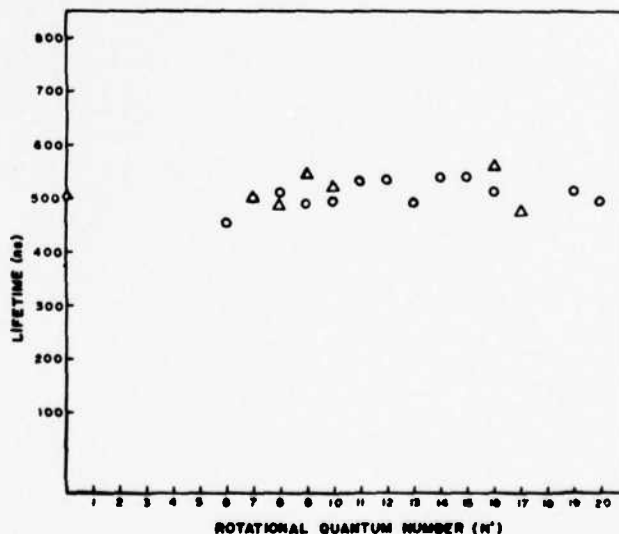

FIG. 1. The lifetime of rotational levels of the $A^2\Delta$ state. \circ corresponds to $v' = 0$ levels, Δ corresponds to $v' = 1$ levels, and \blacktriangle corresponds to the bandhead lifetime.

¹This research was supported under ONR Grant N00014-75-C-0477.

²R. Anderson, R. Sutherland, and D. Wilcox, "Radiative Properties of CH and CH⁺ Molecular States," *Nucl. Instrum. Methods* 110, 167 (1973).

³R. A. Anderson, J. Peacher, and D. M. Wilcox, "Radiative lifetime of the B²Σ⁻ state of CH," *J. Chem. Phys.* 63, 5287

(1975).

⁴P. Erman, "Applications of High Resolution Measurements of Optical Lifetimes," in *Proceedings of the 4th International Beam Foli Conference, Gallinburg, Tennessee, September 15-19, 1975*.

⁵I. Kovacs, *Rotational Structure in the Spectra of Diatomic Molecules* (American Elsevier, New York, 1969).

To be published: "Progress in Atomic Spectroscopy"
(Plenum Press)

SPIN AND COHERENCE TRANSFER IN PENNING IONIZATION

L.D. Schearer and W.F Parks

University of Missouri-Rolla
Rolla, Missouri, U.S.A

I. INTRODUCTION

The Penning ionization process has been effectively used as a mechanism for energy transfer from one species to another. Penning processes are special cases of collisions of the second kind in which a portion of the internal energy of the first species is utilized to ionize and excite the second species. This mechanism has been successfully applied in the He-Cd and He-Zn lasers in which the laser levels are excited states of the Cd or Zn ions which have been populated by the Penning collision between helium metastable atoms and the Cd or Zn ground state neutral atom. The Penning process has also been used as a convenient and efficient source of ground state ions. In a recent series of measurements⁽¹⁾ ensembles of ground state ions of Mg, Ca, Zn, Sr, Cd, and Ba were formed with sufficient densities to perform conventional Hanle experiments. In this way the radiative lifetimes and depolarization cross-sections of the first excited $2p_{3/2}$ states of the ions were determined.

In this article we discuss the phenomenon of spin exchange and coherence transfer in the population of the Zeeman levels of ions by the Penning ionization process.

II. SPIN TRANSFER

Consider the Penning collision between a triplet metastable helium atom possessing an excitation energy of 19.8 eV and a strontium atom:

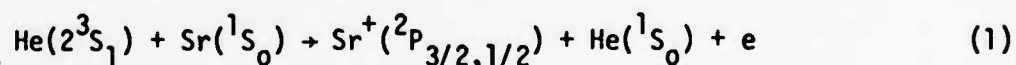

In this particular reaction the ejected electron has approximately 11 eV kinetic energy and the ion is left in an excited state. It has been estab-

lished that the Wigner spin rule is satisfied for Penning collisions. It is through the conservation of spin that an orientation of the metastable helium atoms can induce an orientation of the resulting ions.

To illustrate this point we assume that an ensemble of $\text{He}(2^3S_1)$ atoms has been prepared in which all the atoms have a total angular momentum of \hbar projected onto some fixed space z-axis, commonly the direction of an applied static magnetic field. This means, of course, that both electrons on a $\text{He}(2^3S_1)$ atom have a z-component of spin angular momentum $+\hbar/2$. In the Penning collision the $\text{He}(2^3S_1)$ atom is de-excited to its ground state $\text{He}(1^1S_0)$, an electron is ejected, and the strontium ion is formed in a spin doublet. In order to satisfy the Wigner spin rule the ejected electron will have z-component of spin angular component of $+\hbar/2$. The electrons in the ion however will have orbital angular momentum to which the spin is coupled. In the cited reaction we are dealing with a 2P ion. We will assume here that the $+\hbar$ and 0 states of orbital angular momentum are randomly populated in this process. The states of the ion are then obtained by combining $+\hbar/2$ z-component of electron spin with each possible orbital angular momentum. In general any coherence between $^2P_{3/2}$ and $^2P_{1/2}$ multiplets is quickly destroyed and the resulting fractional populations of the Zeeman levels are for

$$^2P_{3/2}: n_{3/2} = 1/3, n_{1/2} = 2/9, n_{-1/2} = 1/9, \text{ and } n_{-3/2} = 0,$$

and for

$$^2P_{1/2}: n_{1/2} = 1/9, \text{ and } n_{-1/2} = 2/9$$

and the ions are therefore oriented. It should be noted that since an electron can be oriented but not aligned, an alignment of the initial metastable helium atom will have no effect on the states of the ions produced in Penning collisions.

III. EXPERIMENTAL CONDITIONS FOR OBSERVING SPIN TRANSFER

The fast flowing helium afterglow is a convenient environment in which to observe the effects of Penning collisions between $\text{He}(2^3S_1)$ atoms and an impurity species such as strontium since the reaction takes place in an electric field-free region. Thus, the optical emission from levels of the ion represent the effects of the Penning process uncomplicated by radiation which might be produced by excitation with hot electrons. A schematic representation of the experimental apparatus is shown in fig. 1.

It is also possible to orient the $\text{He}(2^3S_1)$ atoms in the afterglow by optical pumping techniques. In this case a spin polarization of this system on the order of 30 - 40% is routinely obtainable. In the flowing afterglow there is no preferred direction for the Penning collisions between the $\text{He}(2^3S_1)$ atom and the impurity atom. In the absence of any preferred collision axis it is possible to assume that the various orbital angular momentum states are randomly populated in the formation of the ensemble of Penning ions. It follows then from our earlier discussion that this experimentally induced orientation of the $\text{He}(2^3S_1)$ atoms will result in the spin polarization of the ejected electrons and the orientation of the Penning ions. Since the excited ion is oriented its emission is polarized and the polarization is readily detected.

The orientation of the Penning ions also makes it possible to perform magnetic resonance experiments⁽²⁾. Figure 2 is the magnetic resonance

spectrum obtained by viewing the polarized emission from the $\text{Cd}^+(5^2D_{5/2} - 5^2P_{3/2})$ transition at 4416 \AA . The magnetic resonance signal at $g = 2$ is due to the $\text{He}(2^3S_1)$ atoms; at $H = 12.0 \text{ Oe}$ is the $g = 1.2$ resonance due to the even isotope of $\text{Cd}^+(5^2D_{5/2})$ level; the resonance at $H = 10.7 \text{ Oe}$ is due to the $F = 2$ component of the odd isotope of the $\text{Cd}^+(5^2D_{5/2})$ level for which $I = \frac{1}{2}$ and occurs with a natural abundance of 25%. The $F = 3$ resonance at $g = 1$ is partially masked by the double quantum resonance signal of the signal of the helium metastable atoms. The width of the magnetic resonance signal yields the radiative lifetime of the excited state. From measurements of this type we have obtained the results shown in Table I.

J. Hamel & J-F. Vienne⁽³⁾ have also used this technique to observe the hyperfine resonance of the $5^2S_{1/2}$ ground state of the odd Cd^+ isotopes. From this they obtained a hyperfine structure constant for this level of $|A| = 14700 \pm 700 \text{ MHz}$.

The polarization of the Penning electrons in an optically pumped flowing afterglow has been demonstrated by G.K. Walters et. al.⁽⁴⁾. They have extracted the Penning electrons from an optically pumped flowing helium afterglow and obtained electron beam currents of $1 \mu \text{ amp}$ with a spin polarization of 30%. Their technique presents a new and practical source of polarized electrons.

IV. COHERENCE TRANSFER IN PENNING COLLISIONS:

HANLE SIGNALS IN ROTATING REFERENCE FRAME

The discussion to this point has only dealt with a static orientation of the metastable helium atoms. As shown by Dehmelt⁽⁵⁾, and Bell and Bloom⁽⁶⁾, it is also possible by optical pumping techniques to prepare and observe the

helium metastable atoms in a coherent superposition of its Zeeman levels. Since, by this method, all the atoms of the ensemble are "in phase" this corresponds to a macroscopic spin polarization which is precessing about the external applied field, H_0 , with an angular frequency given by $\omega_0 = g\mu_B H_0 / \hbar$ where μ_B is the Bohr magneton and g is the Landé factor.

For Penning collisions occurring at a given time t the orientation of the metastable helium atoms at that time induces a corresponding orientation in the ions formed. The orientation of these ions then processes at the ion's natural frequency ($\omega' = g'\mu_B B_0 / \hbar$ with the appropriate g -factor) about the static field. At each instant in time, of course, a new ensemble of Penning ions will be formed with their initial orientation determined by that of the helium metastable atoms. The mathematical equations describing the complete ensemble of ions can be developed, as shown by the authors⁽⁷⁾, using a suitable modification of the model presented by Elbel in section 11.2. We shall present here however, a more intuitive approach.

The coherence induced in the $\text{He}(2^3S_1)$ system plays the same role in Penning excitation as polarized light does in the optical excitation, i.e. the excited ion levels are coherently excited. In the case of optical excitation in an applied static magnetic field the Hanle signals would be observed. Consequently, if we consider the systems from the frame of reference rotating with the orientation of the metastable helium atoms, the Hanle signals should be observed from the excited ions. This frame of reference will be rotating with angular frequency ω_0 . The Hanle signal depends on the precession rate of the orientation of the excited state. In this rotating coordinate system the magnetic moment of the excited ion will be observed to precess about the axis of

the external magnetic field with an angular frequency

$$\omega = (g'\mu_B H_0/\hbar) - (g\mu_B H_0/\hbar) \quad (2)$$

i.e. the difference of the natural precession frequencies of the orientations of the ions and the metastable helium atoms. The (circularly polarized) Hanle signals, as observed in the rotating reference frame, are given by

$$P^\omega = A/(1 + \omega^2 \tau^2) \quad (3)$$

and

$$P' = A\omega\tau/(1 + \omega^2 \tau^2) \quad (4)$$

where P is the signal in phase with the orientation of the helium metastable atom and P' that leading this orientation. τ is the relaxation time for the orientation of the ions from which the radiative lifetime can be extracted and A is a constant determined by the particular system and apparatus.

On transforming to the laboratory frame and utilizing eq(2) we obtain

$$P_L = A \cos(\omega_0 t) / [1 + \omega_0^2 (1 - g'/g)^2 \tau^2] \quad (5)$$

where we have arbitrarily chosen this signal to be maximum at $t = 0$. The other component of the signal is

$$P'_L = A\omega_0 (1 - g'/g)\tau \sin \omega_0 t / [1 + \omega_0^2 (1 - g'/g)^2 \tau^2] \quad (6)$$

P_L and P_L' are the signals obtained from the components in phase and in quadrature with the orientation of the metastable helium atoms, respectively.

V. EXPERIMENTAL OBSERVATIONS OF COHERENCE TRANSFER

In the laboratory frame of reference the Hanle signal is modulated due to the precession of the orientation of the metastable helium atoms and damped due to the loss of phase coherence in the ion ensemble. Experimental observations of the coherence transfer proceeds in a straightforward manner with apparatus essentially identical to that shown in figure 1. The single important difference is that ion emission is observed through a circular analyzer perpendicular to the applied magnetic field. The observation of the transfer of the phase coherence (or equivalently, the transfer of the transverse component of spin angular momentum) to the excited ion was first reported by Schearer⁽⁸⁾.

Hamel, Margerie, and Barrat⁽⁹⁾ in an elegant experiment have recently reported the observation of the magnetic field dependence of the amplitude of these Penning ion Hanle signals. The results they obtained are shown in figure 3 for the amplitudes of P_L and P_L' for the $\text{He}^m + \text{Cd} \rightarrow \text{Cd}^+(^2D_{5/2}) + \text{He} + e$ Penning process. The ion emission is at 4416 \AA ($5^0D_{5/2} - 5^2P_{3/2}$). The experimental points are labeled + and o and the solid curve is a plot of the amplitudes appearing in eqs. 5 and 6 with $g' = 1.1998 \pm 0.0001$ and $\tau = 0.800 \pm 0.040 \text{ \mu s}$. Using this technique Hamel et. al.⁽¹⁰⁾ have also obtained radiative lifetimes for the $(4f)^2F$ levels of Mg^+ .

This technique holds considerable promise for the measurement of radiative levels of ions which are energetically accessible in a Penning collision with He^m . The method effectively extends the use of the Hanle

effect to levels of ions which are not necessarily optically connected to a ground or metastable level of the ion.

VI. ACKNOWLEDGMENTS

The authors wish to acknowledge the support of the Office of Naval Research which has led to the development of much of the work reported here.

1. F.H.K. Rambow and L.D. Schearer, Phys. Rev. A 14, 1735-1738 (1976)
2. L.D. Schearer, Phys. Rev. A 10, 1380-1394 (1974)
3. J. Hamel and J-F. Vienne, Opt. Commun 7, 83085 (1973)
4. P.J. Keiher and G.K. Walters, Fourth International Conference on Atomic Physics, Abstracts of Contributed Papers, Heidelberg July 22-26, 1974, pp 386 - 389
5. H.G. Dehmelt, Phys. Rev. 105, 1924-25 (1957)
6. W.E. Bell and A.L. Bloom, Phys. Rev. 107, 1559-1565 (1957)
7. W.F. Parks and L.D. Schearer, Phys. Rev. Lett. 29, 531-533 (1972)
8. L.D. Schearer and L.A. Riseberg, Phys. Rev. Lett. 26, 599-601 (1971)
9. J. Hamel, J. Margerie, and J-P. Barrat, Opt. Commun. 12, 409-413 (1974)
10. J. Hamel, J-P. Barrat, Opt. Commun. 18, 357-360 (1976)

TABLE I. Lifetime Measurements

<u>ION</u>	<u>LEVEL</u>	<u>LIFETIME</u>
Cd ⁺	5 ² D _{5/2}	0.775 ± 0.027 μs
Zn ⁺	4 ² D _{5/2}	1.61 ± 0.11 μs
Zn ⁺	4 ² D _{3/2}	2.22 ± 0.11 μs

Fig. 1. Schematic representation of apparatus. The expanded region region shown is used to inhibit condensation of metal atoms on glass surfaces.

Fig. 2. Magnetic resonance signals from Cd^+ .

Fig. 3. Hanle signals from the $(4d^9 5s^2)^2 D 5/2$ level of Cd^+ . +: experimental amplitude of P_L , o: experimental amplitude of P_L' .

- I Introduction
- II Spin Transfer
- III Experimental Conditions for Observing Spin Transfer
- IV Coherence Transfer in Penning Collisions:
 - Hanle Signals in a Rotating Reference Frame
- V Experimental Observation of Coherence Transfer
- VI Acknowledgments

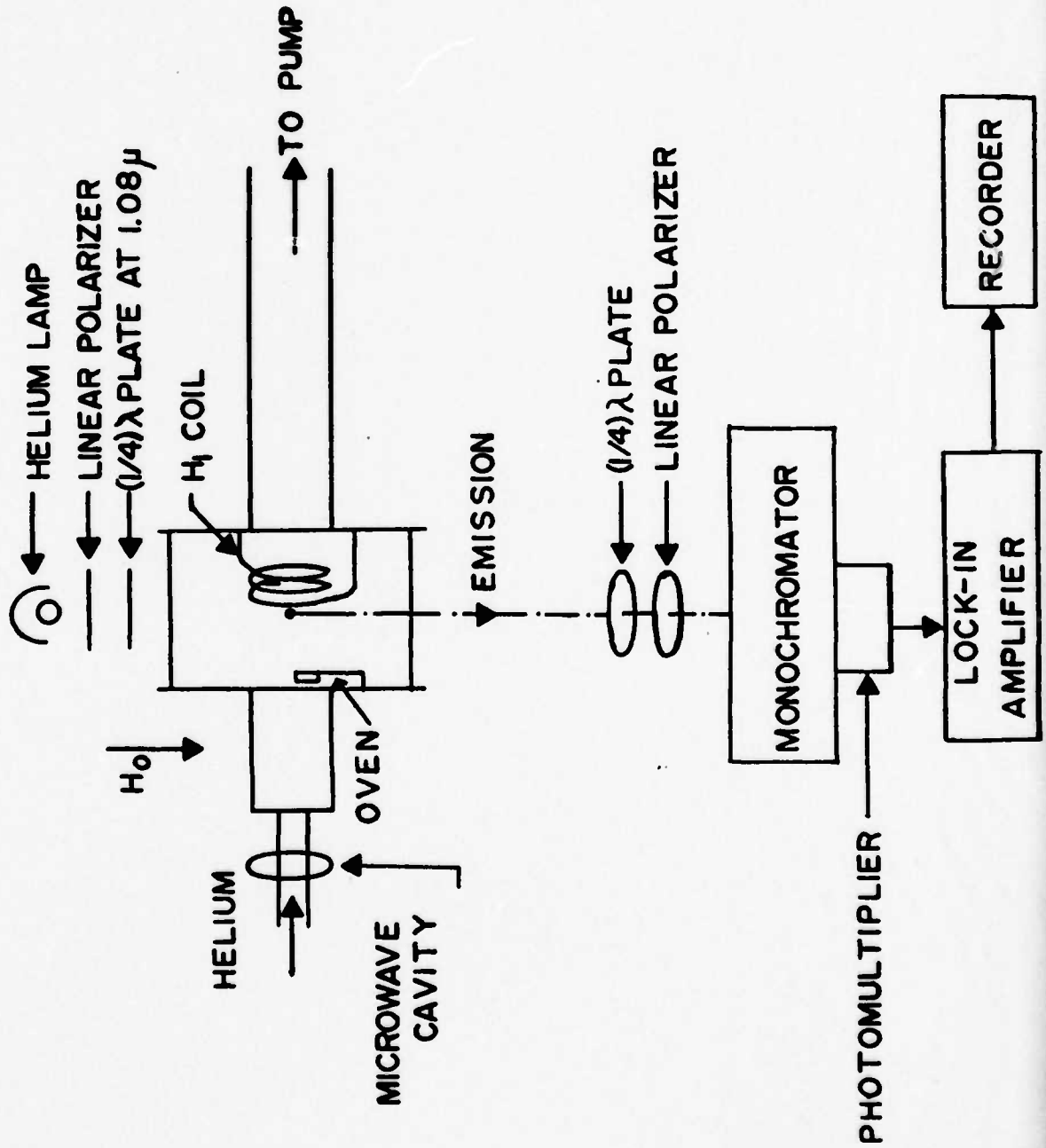

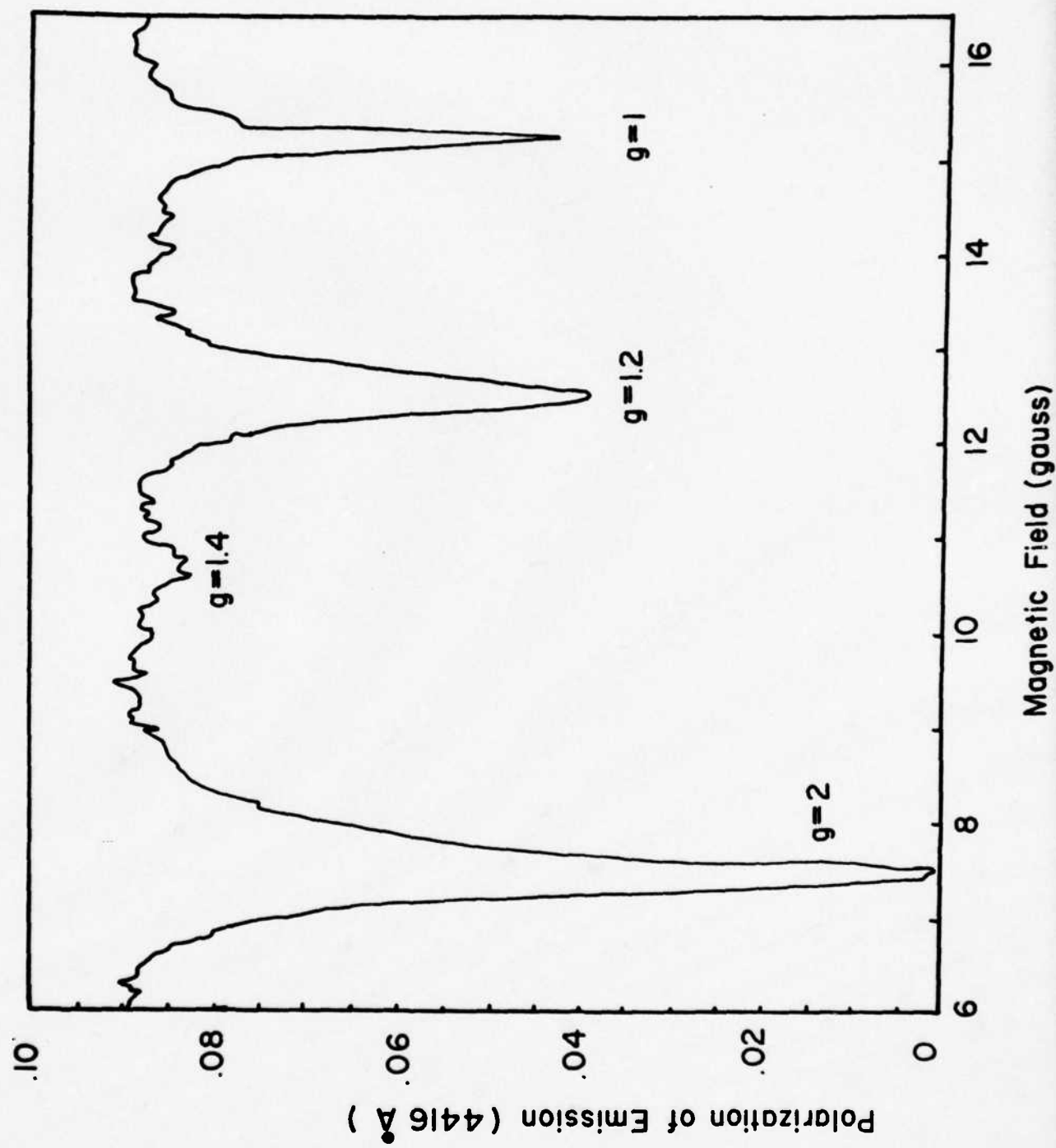

Submitted to Rev. Sci. Instr.

A HIGH FLUX BEAM SOURCE OF FAST NEUTRAL HELIUM[†]

by

D.W. Fahey, L.D. Scheerer*, and W.F. Parks

PHYSICS DEPARTMENT
UNIVERSITY OF MISSOURI
ROLLA, MISSOURI 65401

Abstract

A high flux beam source of fast neutral helium has been constructed by extending the designs of previous authors. The source is a dc or pulsed electric discharge in an expanding gas nozzle. The beam produced has a flux on the order of 10^{15} atoms/sec-sr and a mean velocity on the order of 10^7 cm/sec. The composition of the beam has been determined by the use of the particle detectors and by the observation of the excitation of certain target gases. An upper bound of 3.7×10^{-5} has been estimated for the $\text{He}(2^3S_1)/\text{He}(1^1S_0)$ beam density ratio and a value of 0.2 found for the $\text{He}^+/\text{He}(1^1S_0)$ beam density ratio.

I. INTRODUCTION

The construction of high flux metastable beam sources has been previously reported in this journal by J. Q. Searcy¹ and E. L. Leasure et al.² Both designs used an expanding gas nozzle and skimmer arrangement with a continuous high voltage dc discharge in the expanding gas. In both designs, the sources produced helium metastable atoms with a total flux of less than 10^{12} atoms/sec-sr. and with energies lower than 5 eV.

In this article we report the design, construction, and characterization of a source which produces a dc or pulsed beam of predominantly helium ground state neutral atoms at energies of approximately 1 KeV and fluxes exceeding 10^{15} atoms/sec-sr. The high beam densities considerably simplify the observation of optical emission resulting from the collision of the fast neutral helium atoms with impurity species in the interaction region. Time of flight measurements, pulsed excitation of the source, and the observation of optical emission spectra from strontium as a target gas, are used to characterize the source.

II. SOURCE DESIGN

The source is essentially a high voltage discharge maintained between a sharp needle and a cone-shaped anode with a small hole at the apex. The discharge exists across a substantial pressure gradient created by differentially pumping a gas nozzle. The needle tip was in the pressure range of 40 - 80 Torr. while in front of the anode the pressure was maintained in the vicinity of 2.5×10^{-4} Torr. In the region behind the anode (the reaction region) the background pressure was less than 5×10^{-6} Torr.

Our source design is shown in Figure 1. A Cajon Ultra-Torr fitting is mounted in a vacuum chamber wall and seals around a 7 mm O.D. Pyrex glass tube (a) that extends several centimeters into the chamber. A machined piece of boron nitride (b) forms a cap for the end of the glass tube and a small hole drilled in this serves as the nozzle. The skimmer is a cone-shaped piece of stainless steel (c) with a small hole at the apex. Behind the nozzle, inside the glass tube is a common nickel plated sewing needle (d) supported to lie along the axis of the tube. The skimmer piece is attached with non-conducting epoxy to a vacuum wall to allow differential pumping of the source. This created two independently evacuated regions that will be referred to as the source and reaction region, respectively. A relatively slow 300 liter/sec diffusion pump was attached to the source region. The positive high voltage needed to initiate and sustain the discharge was provided between the needle (anode) and the skimmer (cathode). Research grade helium was metered into the glass tube behind the nozzle by a micrometer leak valve. Absolute nozzle pressure measurements were made with a Wallace and Tiernan dial gauge. A triode ionization gauge was used as an indirect measure of the nozzle pressure and a means to alter the pressure reproducibly.

, Our source was capable of being operated by creating either a dc or pulsed discharge in the expanding gas. The dc discharge used a conventional Fluke 410B high voltage power supply (0 - 10 KV, 0 - 10MA) with overcurrent protection. The pulsed mode used a 5C22 hydrogen thyratron to transfer the energy in a 0.012 microfarad low inductance capacitor to the discharge region.

The operation of the discharge was quite simple. After obtaining an initial high vacuum in the chamber, helium was allowed to bleed into the region behind the nozzle by opening the leak valve. At a nozzle pressure of 50 torr, a dc voltage above 4KV initiates and sustains the discharge. In the same pressure range, a 5 - 10 KV charge on the capacitor in the pulsing circuit would consistently initiate the discharge at each pulse with a repetition rate up to 200 Hz. The upper limit on the repetition rate was primarily determined by the power limitations of the circuit components.

The discharge was easily visible to the eye as a pinkish-orange glow between the nozzle and skimmer in both the pulsed and dc mode of excitation. The discharge activity was confined under normal conditions to a cylindrically shaped volume extending from the nozzle to the skimmer hole with a perceived radius of several skimmer hole diameters. Behind the nozzle inside the glass tube the discharge was more intense and confined between the needle tip and nozzle hole.

The intensity of the discharge seemed to be given by the product of pressure and voltage, where the intensity would be a qualitative measure of the ionizing activity outside the nozzle. For nozzle pressures near 80 torr and above and for dc or pulsed voltages of 9 - 10 KV, the discharge would become unstable as evidenced by arcing between the nozzle and ground walls and by the ignition of a weak discharge in the entire source region. The highest stable intensity that the source could maintain was essentially determined by the pumping speed in the source region. At all values of the

source parameters for which arcing to ground would not occur, the output of the source as measured by particle currents was extremely stable and reproducible for both the pulsed and dc modes.

III. BEAM DIAGNOSTICS

To properly characterize the source, it was necessary to determine the different component species of the beam and their respective velocities. Since the interest in our laboratory is in both the metastable and ground state neutral helium, our primary effort was to analyze the beam for these two species by two basic methods.

A. PARTICLE DETECTION METHOD

In the first method, a faraday cup and a particle multiplier were used. Specifically, the faraday cup was 2.5 cm diameter by 2.5 cm deep thin-walled stainless-steel cup with a coarse nickel mesh bias grid. In this arrangement, the cup was capable of a nearly absolute measurement of the charged components of the beam assuming the ions were singly charged. With the proper bias the secondary electron current from the neutral beam flux was also measured. In general, since the coefficient of electron ejection is only easily determined for atomically clean surfaces, absolute measurements of the neutral flux were precluded although relative measurements were still valid.

The particle multiplier used was an EMI/GENCOM 9603/2B windowless electron multiplier. As a general rule the multiplier is not sensitive to particles with less total energy than approximately 20 eV for helium. This implies that helium metastables of negligible translational energy would be detected since they possess approximately 20 eV internal energy while helium ground state neutrals would be required to have at least 20 eV in kinetic energy corresponding to a velocity of 3.1×10^6 cm/sec. The threshold for efficient photon detection is lower and would include wavelengths on the order of 200 nm or less.

The usefulness of both detectors was enhanced by the simultaneous use of electrostatic sweep plates which permit the removal of any charged component from the beam and the ratio of charged components to neutral components to be determined.

B. OPTICAL EMISSION SPECTRA FROM ELEMENTAL IMPURITY

The second method of particle detection was the observation of the excitation produced by the beam in an elemental impurity whose vapor was titrated into the beam path. Optical signals were monitored as evidence of target excitation. This method was crucial in determining the metastable flux since their principle reaction with elemental impurities is through the Penning ionization reaction which yields only ionic states of the impurity. These reactions have been well studied in flowing afterglow experiments and the characteristic spectra recorded for various elements^{3,4}. In this work, the class of group II elements, primarily strontium, were used as targets since their characteristic Penning spectra have been measured in our laboratory⁴. The characteristic neutral and ion emission from the target impurities was identified using the Charlotte Moore Tables of atomic energy levels⁵.

The high flux yield of the source permitted simple integration techniques to observe the emission spectrum of the target in both the dc and pulsed operating modes. The optical detection apparatus consisted of a quartz lens and a 0.25 m Jarrell-Ash monochromator using a 9783B EMI/GENCOM photomultiplier mounted outside the vacuum region chamber at 90 degrees with respect to the beam axis. The effective solid angle of the detection system was 2.1×10^{-3} sr. The impurity vapor was introduced into the beam path by resistively heating a small crucible of the element inside the vacuum region in close proximity to the beam.

The optical emission from a strontium target excited by the beam is shown in Figure 2. As seen in the sample spectrum for the beam interaction with strontium, the optical emission is dominated by two lines of wavelength 407.9 nm and 460.9 nm. From the table of atomic energy levels, these lines correspond to transitions in the ion and neutral species of strontium, respectively. The ratio of ion excitation to neutral excitation is seen to be approximately 0.25. The charged component of the beam, presumably He^+ , produced approximately 50% of the ion emission and made a negligible contribution to the neutral strontium emission. The conclusion is made that the neutral components of the beam excite the neutral levels of strontium at a rate approximately 8 times greater than levels of the strontium ion.

The neutral beam may contain both the ground state helium atoms as well as metastable components. The intensity ratio found above may now be used to provide an upper limit on the density of the metastable components. Since helium metastable atoms can only Penning ionize the impurity, the observation of strontium neutral emission must be attributed to excitation by collisions with helium ground state neutral atoms. The excitation of the observed level at $21,698 \text{ cm}^{-1}$ in strontium requires a minimum helium atom velocity of $1.1 \times 10^6 \text{ cm/sec}$.

Using experimental values for related Penning ionization cross sections and a value for the cross section for neutral excitation by fast neutrals, a value for the ratio of metastables to fast ground state neutrals in the beam can be estimated. The values for the Penning ionization cross sections for zinc and cadmium are known from pulsed afterglow experiments⁶. The average value of these cross-sections of $3.7 \times 10^{-15} \text{ cm}^2$ is used as a good approximation to the strontium cross section. In the case of neutral excitation, the cross section for excited target emission at a specific wavelength is expected

to be smaller than the relatively large Penning cross sections. Kempter has reviewed neutral-neutral collisions and compiled estimated absolute emission cross sections for various systems⁷. The neon emission cross sections for He on Ne at 920 eV were thought to closely represent similar cross sections for He on Sr at 800 eV. Therefore, as a first approximation a value of $1.1 \times 10^{-18} \text{ cm}^2$ was chosen to represent the neutral excitation cross section. Thus, using the cross section ratio and the ratio of observed optical signals, the metastable to neutral ground state flux ratio is calculated to be 3.7×10^{-5} . This value most importantly represents an upperbound on the flux ratio which is clearly much less than unity.

A search for source conditions that would enhance the ion excitation over the neutral excitation was unsuccessful. The source was characterized as varying continuously with its parameters, the most important of which would be the nozzle pressure, anode voltage, pumping speed, and the relative spacing of the nozzle components. Variations over the range of useful values resulted primarily in a change in overall intensity of the beam and not in the character of the output as measured by the excitation ratio. As a representative example, Figure 3 shows the level of neutral excitation as a function of anode voltage at a typical operating pressure. The related group II elements calcium and cadmium were also used as the impurity with the result that a characteristic neutral line was also populated over a characteristic ion line by the same ratio observed in strontium.

C. PARTICLE FLUX AND VELOCITY MEASUREMENTS

The particle multipliers were used for time of flight analysis and particle flux measurements. In computing values for the beam flux, two assumptions were made. First, it was assumed that all ion excitation not due to charged components would be attributed to the metastable species and that the

resultant value for the metastable flux would represent an upper limit. Implicit in this assumption is the fact that the photon contribution to ion excitation is being neglected. This fact is supported by the absence of a significant photon peak in the time of flight analysis and the relatively lower cross section. Second, the threshold of 20 eV for the multiplier was thought not to exclude the detection of relevant particles because charged components were likely to have energies on the order of the anode voltage, metastables have 20 eV of internal energy, and neutrals were assumed to have been formed from energetic ions. This assumption is self-consistent since the neutral flux was measured to have an average energy of 800 eV.

Using the particle multiplier, 20% of the beam in the pulsed and dc mode was found to be charged. To avoid using a value for the multiplier gain, the biased faraday cup was used to get an absolute value for the charged current. A typical value of 5×10^{-8} amperes for the charged current yields a value of 1.56×10^{12} particles/sec for the total flux incident on the multiplier. Using the effective solid angle of 4.9×10^{-4} sr, the total particle flux is determined to be 3.2×10^{15} particles/sec-sr.

A velocity measurement by time of flight was made with the multiplier which could be moved under vacuum as much as 60 cm and therefore avoided the difficulty of determining a zero in time. The measurement was made noting the shift in the leading edge of the particle signal for an in situ displacement of the multiplier. The width of the particle pulse was 0.5×10^{-3} sec with an average velocity of 2×10^7 cm/sec corresponding to an energy of 800 eV for helium. The optical excitation signal from the impurity, which would be observed simultaneously with the particle multiplier signal, was always seen to have the same pulse shape and same position in time as the particle signal. This allowed one to confidently conclude that the particles causing the excitation were indeed the particles detected by the multiplier.

IV. CONCLUSIONS

In conclusion, an extension of previous work on the construction of a high flux beam source of helium neutrals has led to new results. An extremely stable particle flux of 10^{15} atoms/sec-sr with a mean velocity of 2×10^7 cm/sec has been generated in both a pulsed and dc mode. The source has been characterized as a high flux source of fast neutral ground state helium and a relatively low flux source of helium metastables. The high flux yield permits simple optical observation of the excitation produced in collisions of the beam with a target gas. The characterization of the source by optical detection of reactions with impurities is thought to be a significantly more decisive test for the presence of metastables than the use of particle multipliers or total scattering measurements.

REFERENCES

†Research supported by Office of Naval Research.

*Visiting Scientist, JILA

1. J. Q. Searcy, *Rev. Sci. Instrum.* 46, 589 (1974).
2. E. L. Leasure, C. R. Mueller, and T. Y. Ridley, *Rev. Sci. Instrum.* 46, 635 (1975).
3. R. C. Bolden, R. S. Hemsworth, M. J. Shaw, and N. D. Twiddy, *J. Phys. B* 3, 61 (1961).
4. L. D. Schearer and F. H. K. Rambow, to be published.
5. Charlotte E. Moore, Atomic Energy Levels Derived from the Analysis of Optical Spectra (Washington: Government Printing Office, 1971), Vol. 1 - III.
6. L. A. Riseberg, W. F. Parks, and L. D. Schearer, *Phys. Rev. A* 8, 1962 (1973).
7. V. Kempter, Molecular Scattering: Physical and Chemical Applications, edited by K. P. Lawley (Wiley & Sons, 1975), Vol. XXX, p. 417.

FIGURE CAPTIONS

- Figure 1. Beam source schematic indicating pyrex tube (a), boron nitride nozzle (b), skimmer (c), and needle (d).
- Figure 2. Partial emission spectrum of strontium excited by the source yield of neutral ground state helium atoms.
- Figure 3. Strontium neutral emission at 460.9 nm due to neutral ground state excitation as a function of source anode voltage.

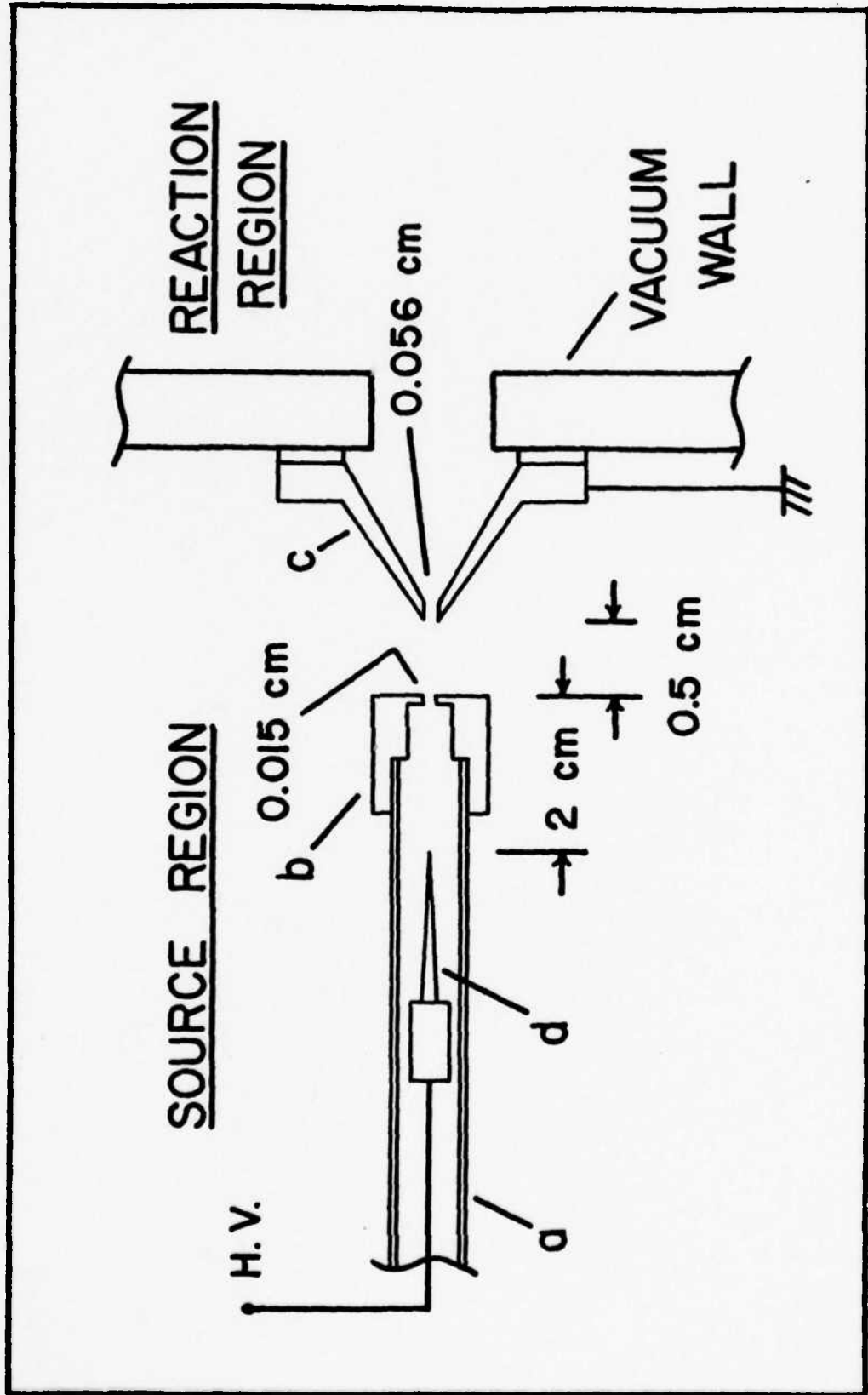

Figure 1.

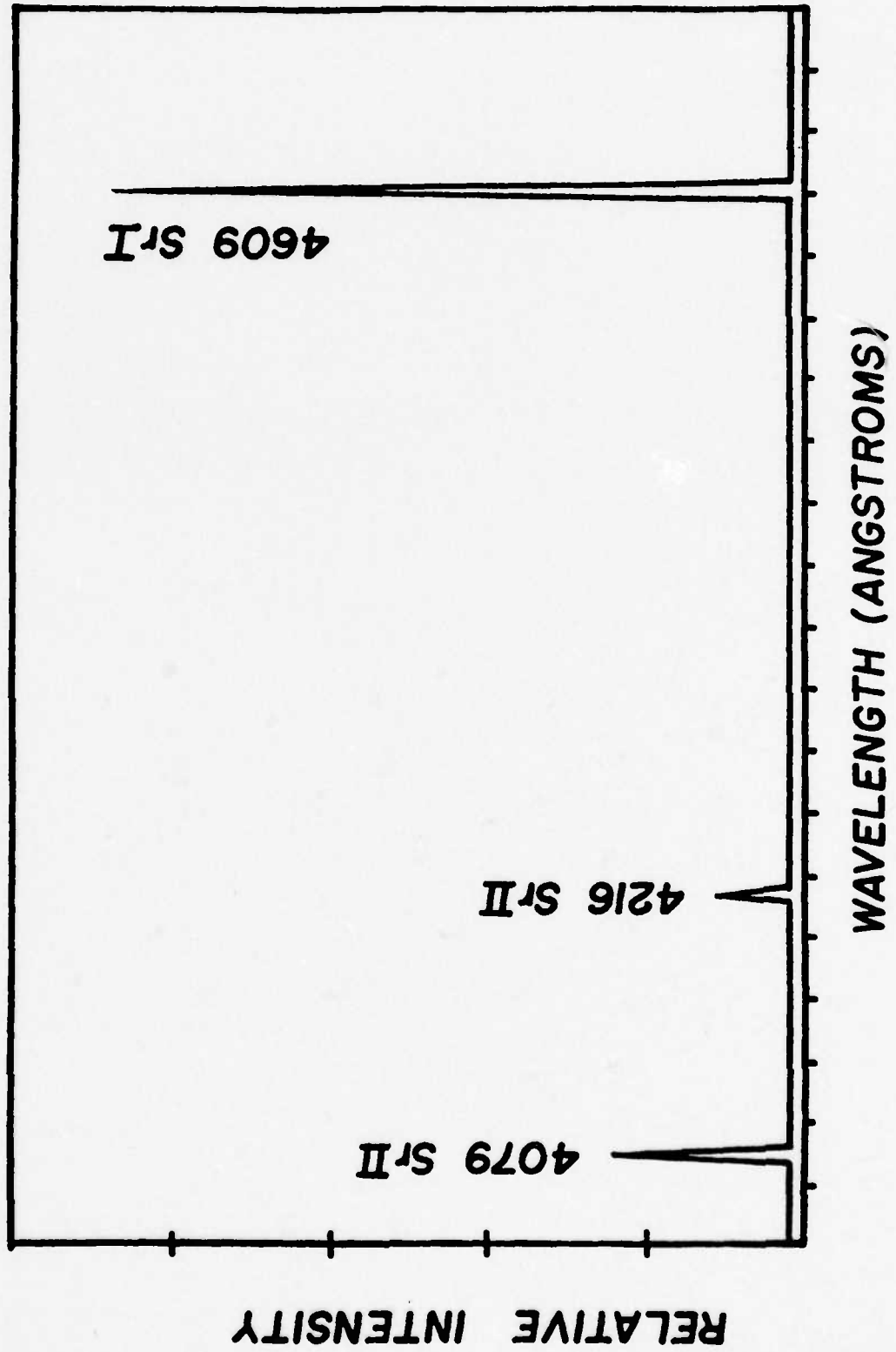

Figure 2

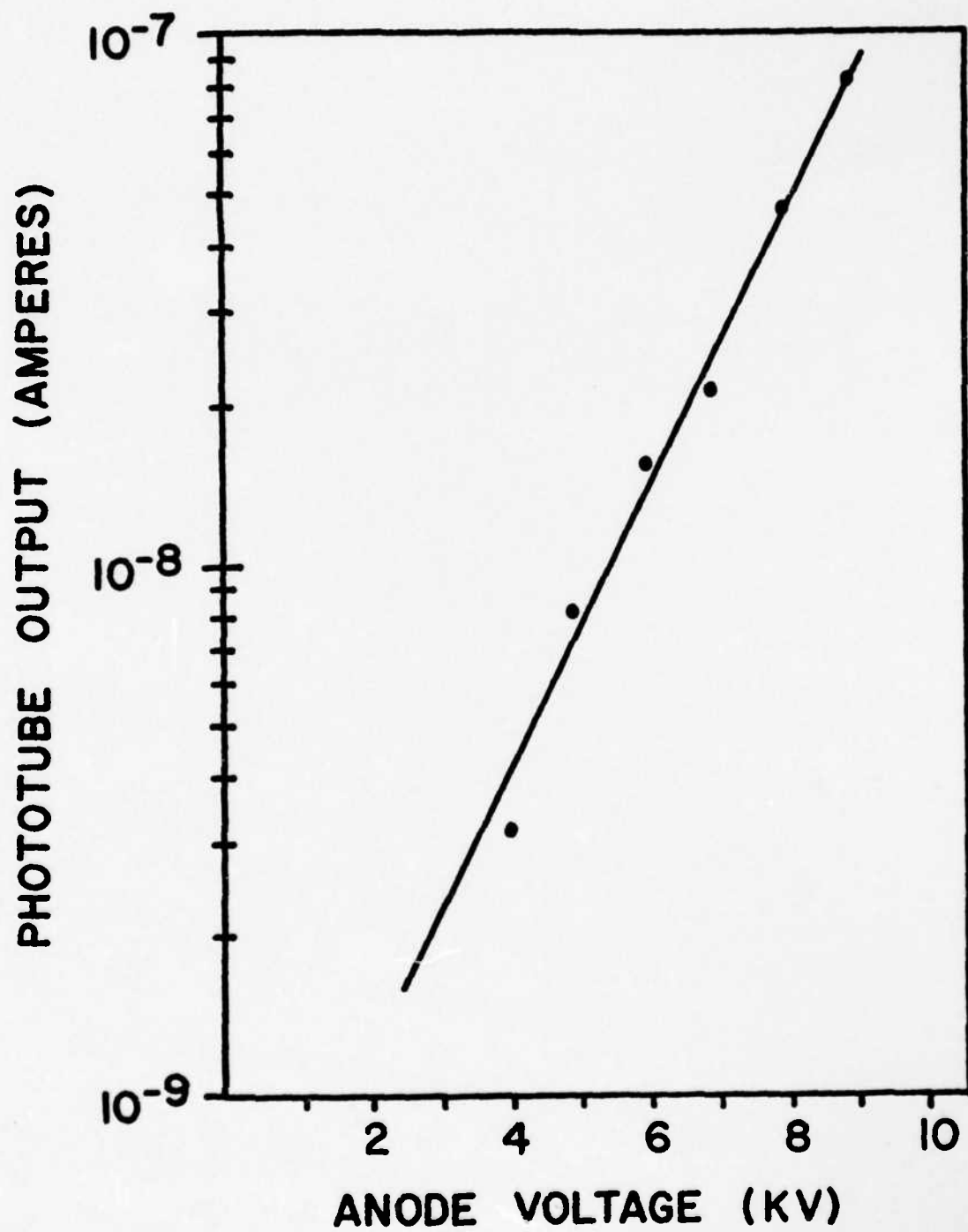

Figure 3.

Submitted to: J. Quant. Elec.

A Xenon-Ion Pumped Blue Dye Laser*

by

D.W. Fahey and L.D. Schearer[†]

Physics Department
University of Missouri
Rolla, Missouri 65401

In this note we report the use of a pulsed xenon-ion laser with an output power of 5 kW at 364.5 nm to pump DPS and a Coumarin dye. Broadband conversion efficiencies exceed 10%. The use of a birefringent filter provides tunable output in the blue region of the spectrum with a bandwidth of 0.08 nm and a pulse width of 120 ns. The observations reported here along with earlier reports utilizing the visible output of the xenon-ion laser to pump the rhodamine dyes [1], [2], [3], demonstrate the possibility of obtaining narrow-band tunable output from 400 nm to over 700 nm in a relatively simple, inexpensive system. Further, the use of the high output power from the xenon-ion laser at 231.5 nm may ultimately permit shorter wavelength dyes to be pumped; thus extending the tuning range into the near UV.

Marling [4] demonstrated the rather unique features of the xenon-ion pulsed laser which in a simple system is capable of providing kilowatts

of peak pulse power at 231.5 nm, 364. nm, and in the blue-green region of the spectrum. We earlier reported the use of the visible output from the xenon-ion laser as a pump source for the rhodamine dyes [2]. The work reported here utilizes the same xenon-ion laser for the pump source with the single exception of the xenon-ion laser cavity mirrors. The active medium is xenon gas at several microns in a discharge volume of 190 cm of 8 mm inside diameter pyrex glass tubing and is excited by a spark-gap controlled 0.3 μ F capacitor charged to 12 kV. The repetition rate of 10 Hz was limited only by the power supply. The cavity was tuned for maximum gain at 364.5 nm(Xe IV) by dielectric coated mirrors which provided 40% output coupling at one surface. The output power at 364.5 nm was measured to be approximately 5 kW with a pulse width of 200 ns (FWHM). Power and pulse width measurements weremade with a calibrated photoconductive silicon detector.

The dye laser cavity configuration is shown in Figure 1. The three-mirror folded cavity with the dye cell at Brewster's angle is the astigmatically compensated cavity used largely in CW dye lasers[5]. The dye cell is a spectrophotometer flow cell made of optical glass with a 1.0 mm path length. The pump beam is brought to a point focus inside the dye cell by a 5 cm focal length lens. The high reflectors, M1 and M2, are dielectric coated spherical mirrors with focal lengths of 12.5 mm and 25 mm, respectively, with a reflectivity in excess of 99% from 400 nm to 500 nm. The optional intracavity tuning element is a birefringent filter consisting of three crystalline quartz plates oriented at Brewster's angle [6]. The optical path length in the three mirror cavity was 15 cm without the filter and 22 cm with the filter.

The initial success of the xenon-ion pumped dye laser has been achieved using two blue dyes: DPS (4,4'-diphenylstilbene) and Coumarin

460 (7D4MC: 7-diethylamino-4-methylcoumarin). When a saturated solution of DPS (less than 1.2×10^{-3} M) in p-dioxane in a closed cell is pumped, lasing is readily observed yielding a broadband output with a 407 nm peak and a 3.2 nm half-width. The peak broadband power is measured to be 500W with a pulse width of 120 ns corresponding to a conversion efficiency of approximately 10%. Insertion of the birefringent filter yielded a narrow-band output of approximately 0.06 nm with 40% peak broadband power. The useful tunable output exceeded the range of 404 nm to 401 nm.

For the lasing of Coumarin 460, a flowcell and reservoir were used to help retard dye deterioration and to allow simple adjustment of the dye concentration. Lasing was observed for dye concentrations between 1.5×10^{-4} M and 3.0×10^{-3} M in ETOH, where the latter value is thought to be near the optimum molarity. The broadband lasing output peaked at 460 nm with a 9.8 nm half-width. The peak power was measured to be 1 kW with a pulse width of 120 ns corresponding to a conversion efficiency of approximately 20%. Insertion of the birefringent filter yielded a narrow-band output of approximately 0.08 nm with 60% peak broadband power. The useful tunable output exceeded the range of 456 nm to 463 nm.

The transmission sidebands of the birefringent filter and the high cavity gain limit the minimum attainable bandwidth. An intracavity etalon could easily be used to provide a bandwidth less than 0.05 nm with a higher power per unit bandwidth. The output coupler which provides 20% transmission from 400 nm to 500 nm is thought to be close to the optimum value for the gain realized in this cavity. Lasing was observed in both dyes with output couplers of 40% and 5% transmission but with a

substantially lower power. With the 4.3 kW pump source, lasing was not achieved using the dye BBQ (4,4"-bis-butylactyloxy-quaterphenyl) which has a broadband peak at 386 nm when pumped with a nitrogen laser. The pump source power is the limiting factor since absorption was occurring as evidenced by the observed fluorescence.

Having achieved tunable output as low as 400 nm, the performance of this system is extrapolated to a tunable output for the continuum of longer visible wavelengths. The blue dyes are sufficient in number that for a given wavelength interval in the blue, an efficient dye can be chosen that has adequate absorption at 364.5 nm. For longer wavelengths, the xenon laser can be tuned to higher power green lines that are highly absorbed in the rhodamine dyes. A tunable output up to 700 nm has been achieved in our laboratory using the rhodamines with perchlorate additives.

Future work on this system will include the addition of an intracavity etalon and the design of a oscillator-amplifier configuration.

References

*Research supported by the Office of Naval Research.

†Visiting Scientist, JILA.

1. T.H. Hansch, A.L. Schawlow, and P. Toschek, "Simple dye laser repetitively pumped by a xenon ion laser", IEEE J. Quantum Electron. (Corresp.), vol. QE-9, pp. 553-554, May 1973.
2. L.D. Scheerer, "A high-power pulsed xenon ion laser as a pump source for a tunable dye laser", IEEE J. Quantum Electron., vol. QE-11, pp. 935-937, December 1975.
3. M.D. Levenson and G.L. Eesley, "Single-mode operation of a repetitively pulsed dye laser", IEEE J. Quantum Electron. (Corresp.), vol. QE-12, pp. 259-260, April 1976.
4. J.B. Marling, "Ultraviolet ion laser performance and spectroscopy- Part I: New strong noble-gas transitions below 2500Å", IEEE J. Quantum Electron., vol. QE-11, pp. 822-834, October 1975.
5. H.W. Kogelnik, E.P. Ippen, A. Dienes, and C.V. Shank, "Astigmatically Compensated Cavities for CW dye lasers", IEEE J. Quantum Electron., vol. QE-8, pp. 373-379, March 1972.
6. G. Holtom and O. Teschke, "Design of a birefringent filter for high-power dye lasers", IEEE J. Quantum Electron., vol. QE-10, pp. 577-579, August 1974.

Figure Captions

Figure 1. A three-mirror astigmatically compensated dye laser cavity for a xenon laser pump beam.

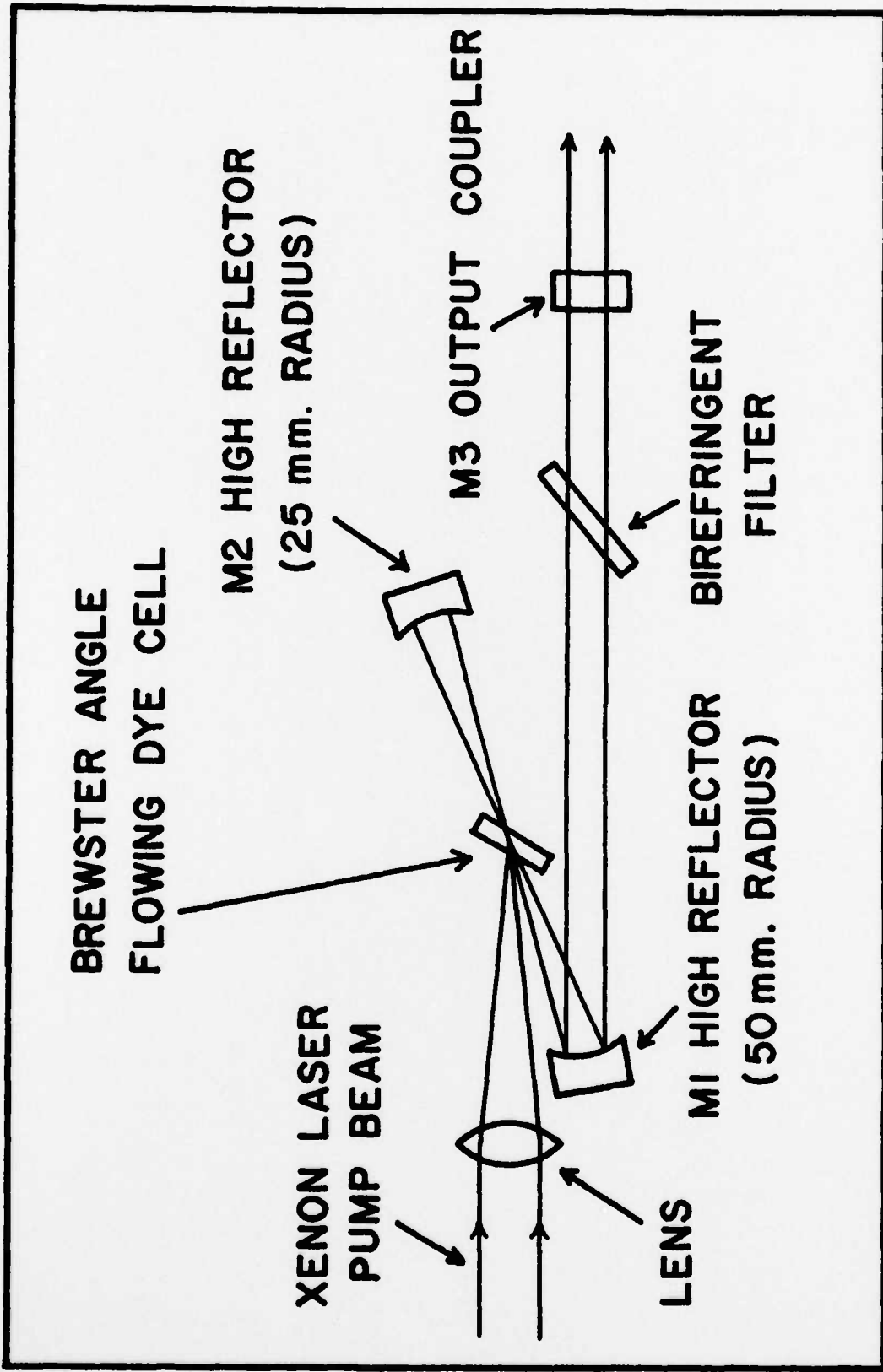

Figure 1.

Submitted to: Physics Letters

Non-Statistical Excitation of the Magnetic Substates of the 1P_1 Level of
Group II Metal Atoms in Collision with 1 keV Helium Atoms*

by D.W. Fahey and L.D. Scheerer[†]

Physics Department
University of Missouri
Rolla, Missouri

Recently Alber, et. al.¹ reported the observation of a non-statistical population of the magnetic substates of the $4^2P_{3/2}$ level of potassium. The potassium was excited in collisions between $K(4^2S_{1/2})$ atoms and the rare gases He, Ne, Ar, Kr, and Xe at lab energies between 50 and 1500 eV. They observed polarized emission from the $K(4^2P_{3/2} - 4^2S_{1/2})$ transition at 766.7 nm. The magnitude of the polarization ranged from +7% to -7% and showed a sharp energy dependence with the polarization tending to zero as the collision energy reached 1000 eV.* They concluded that the molecular states $A^2\Pi$ and $B^2\Sigma$ correlating with the separated atoms ($K, ^2P_{3/2}$ and rare gas, 1S_0) are populated non-statistically with the $B^2\Sigma$ state populated preferentially.

In an attempt to ascertain the influence of a spin-orbit coupling or a $I \cdot S$ coupling on the polarization observed in neutral-

* K-He collision energies only went to 150 eV.

neutral collisions, we looked at collisions of 800 eV He (1S_0) atoms with certain Group II (1S_0) atoms. The Group II atoms have zero nuclear spin and the singlet level, of course, has zero electronic spin.

A neutral helium beam source was designed² to have a high flux on the order of 10^{15} atoms/sec-sr in order to optimize the optical observations. The beam energy was 800 eV with an energy spread of approximately 10%. The source is capable of both pulsed and dc operation with both modes yielding identical target excitation. The metastable component of the beam was estimated to be less than 10^{-5} of the ground state flux. The target vapor was produced by resistively heating a small crucible placed near the beam.

The optical emission spectrum obtained from the He-Sr(1S_0) collision at 800 eV lab energy is shown in Figure 1. No evidence for excitation of the strontium triplet spectrum is observed. The $^1P_1 - ^1S_0$ emission at 460.9 nm was most intense and was viewed at 90 degrees from the beam axis outside the collision chamber. The observed optical emission was polarized along the beam axis with a value of 15%. Similar excitation and polarized emission was observed in Calcium. Excitation was observed but no polarization measurements made in Cadmium and Zinc. All polarization measurements were made with the target gas at essentially zero magnetic field.

The application of a magnetic field orthogonal to both the beam axis and the observation direction reduced the observed polarization and at sufficiently large fields the polarization was reduced to zero. The depolarization of the emission with magnetic field indicates that the 1P_1 magnetic sublevels are coherently excited. The decrease

in optical polarization with increased magnetic field follows a Lorentzian line shape with a half-width given by the product of the g-factor and the radiative decay time for the 1P_1 level. Thus, the collisional excitation process performs the same role as linearly polarized resonance light in conventional zero-field level crossing spectroscopy, i.e. the Hanle effect.³

On the basis of our observations, we conclude that at 800 eV collision energy the molecular state $B^1\Sigma$ correlating with the separated atom states He (1S_0) and Sr (1P_1) is preferentially populated. Thus, states of $m_\ell = 0$ in the Sr (1P_1) level are preferentially populated giving rise to the observed polarization.

REFERENCES

* Research supported by the Office of Naval Research.

† Visiting Scientist, JILA.

1. H. Alber, V. Kempter, and W. Mecklenbrauck, *J. Phys. B* 8, 913 (1975).
2. D.W. Fahey, L.D. Schearer, and W.F. Parks, submitted for publication. D.W. Fahey, M.S. thesis, University of Missouri-Rolla, May 1977. (unpublished)
3. W. Hanle, *Z. Physik* 30, 93 (1924).

FIGURE CAPTIONS

Figure 1. Partial emission spectrum for collisions of 800 eV He atoms (1S_0) with target Sr (1S_0) atoms.

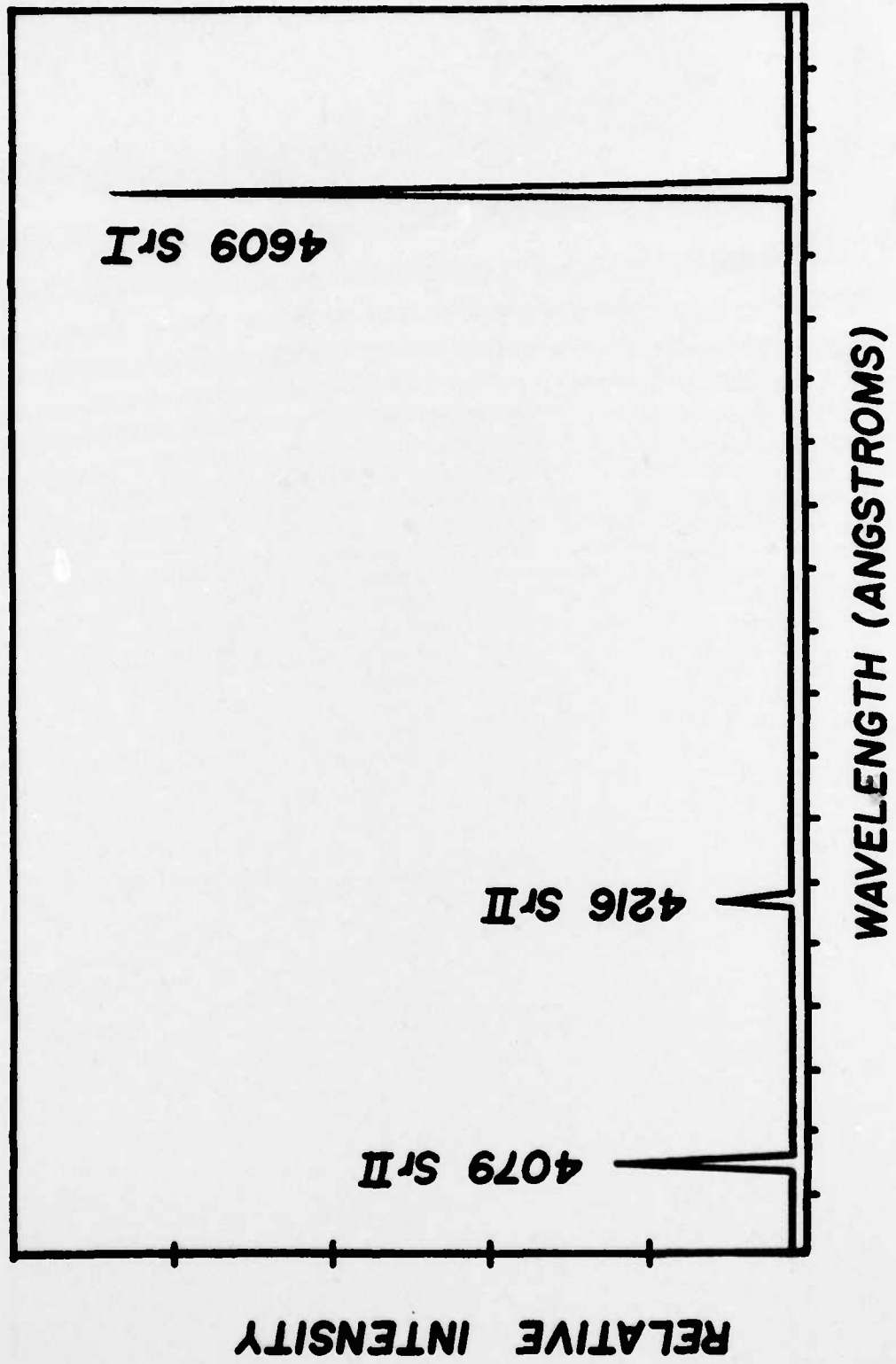

Figure 1

INVESTIGATION OF VOLUME RECOMBINATION KINETICS IN AN ALKALI-
NOBLE GAS AFTERGLOW OF A HIGH POWER, FAST LASER PULSE

The energetics of low temperature plasma involve different competing collision-radiative recombination and ionization processes.⁽¹⁾ The study of these processes is important for the understanding of rocket plumes, high power excimer lasers and more efficient street lighting designs. We have conducted preliminary studies on these processes in an alkali-noble gas systems including Cs-He, K-Ar and K-Kr.

A 4ns, 35 kW N₂-laser pumped dye laser pulse is focussed into an alkali cell with ~ 1 atmosphere of noble gas, and two photons in a stepwise manner excited a resonance state and then ionized it to produce a low temperature plasma. This method has an advantage over conventional electrical or microwave discharge afterglow experiments in that a higher plasma density (up to 10¹⁵cm⁻³) can be obtained, a high buffer gas pressure is possible, the laser induced discharge duration is short (~ 4ns), and direct electron impact excitation of alkali excited states is minimal with a laser pulse so that the ionization is 'cleaner'. A schematic of the apparatus is shown in figure 1.

We monitored the recombination process by measuring the alkali excited state fluorescence spectrum as well as its intensity as a function of time. In figure 2, we show the measured time-integrated intensities of the nS-4p and nD-4p transitions in a K (~ 10¹⁴cm⁻³) and Ar (~ 3 x 10¹⁹cm⁻³) mixture with the pulsed laser tuned to the 4044A second resonance line of K. A typical fluorescence transient under the same conditions is shown in figure 3.

We are presently in the process of collecting more data and working on modeling the system to interpret the data. Preliminary results have been reported at the 30th Gaseous Electronic Conference, Menlo Park, California 1977.

(1) L.M. Biberman, I.T. Yakubov and V.S. Vorobev, Proc. IEEE 59, 555 (1971).

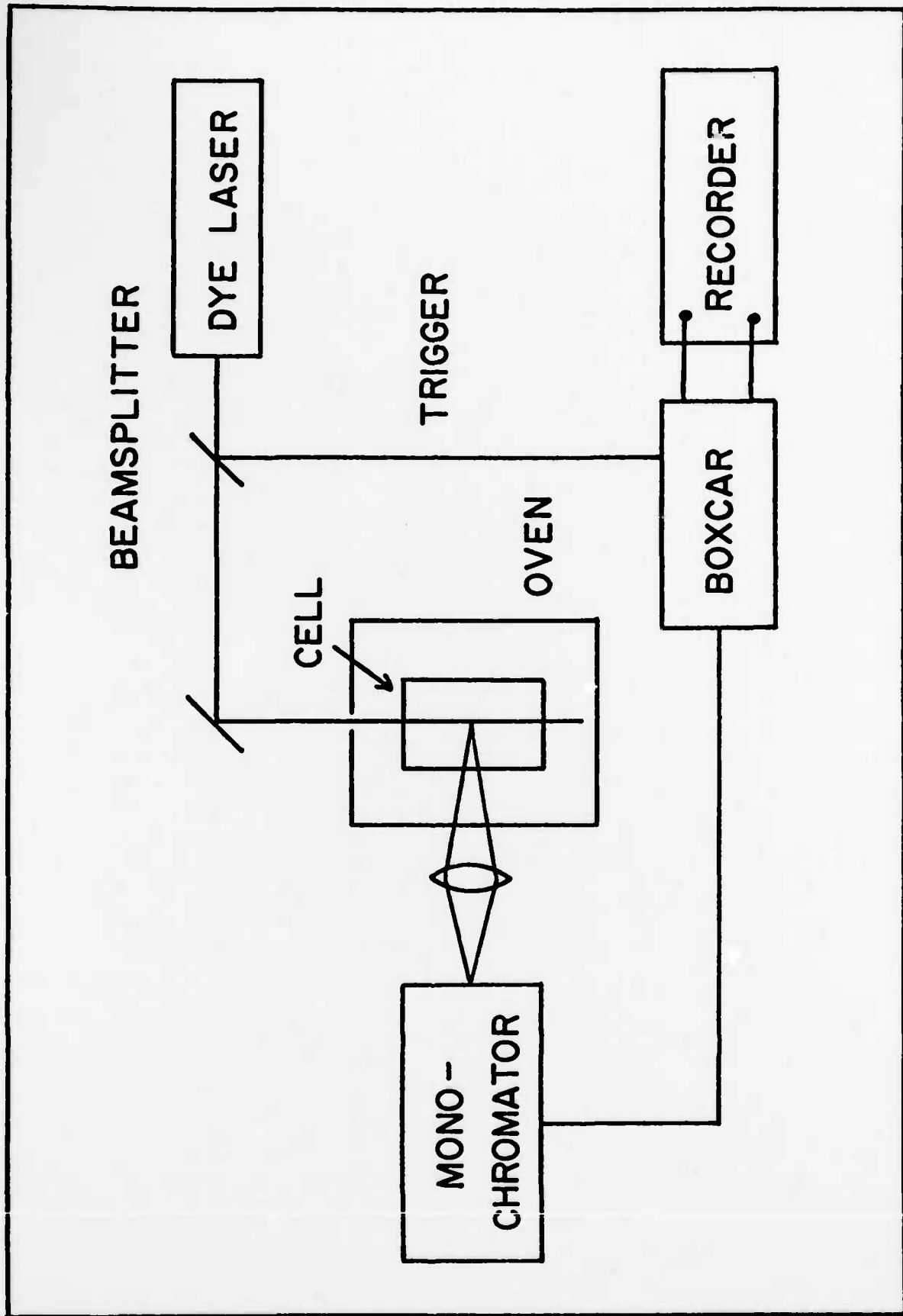

FIGURE 1

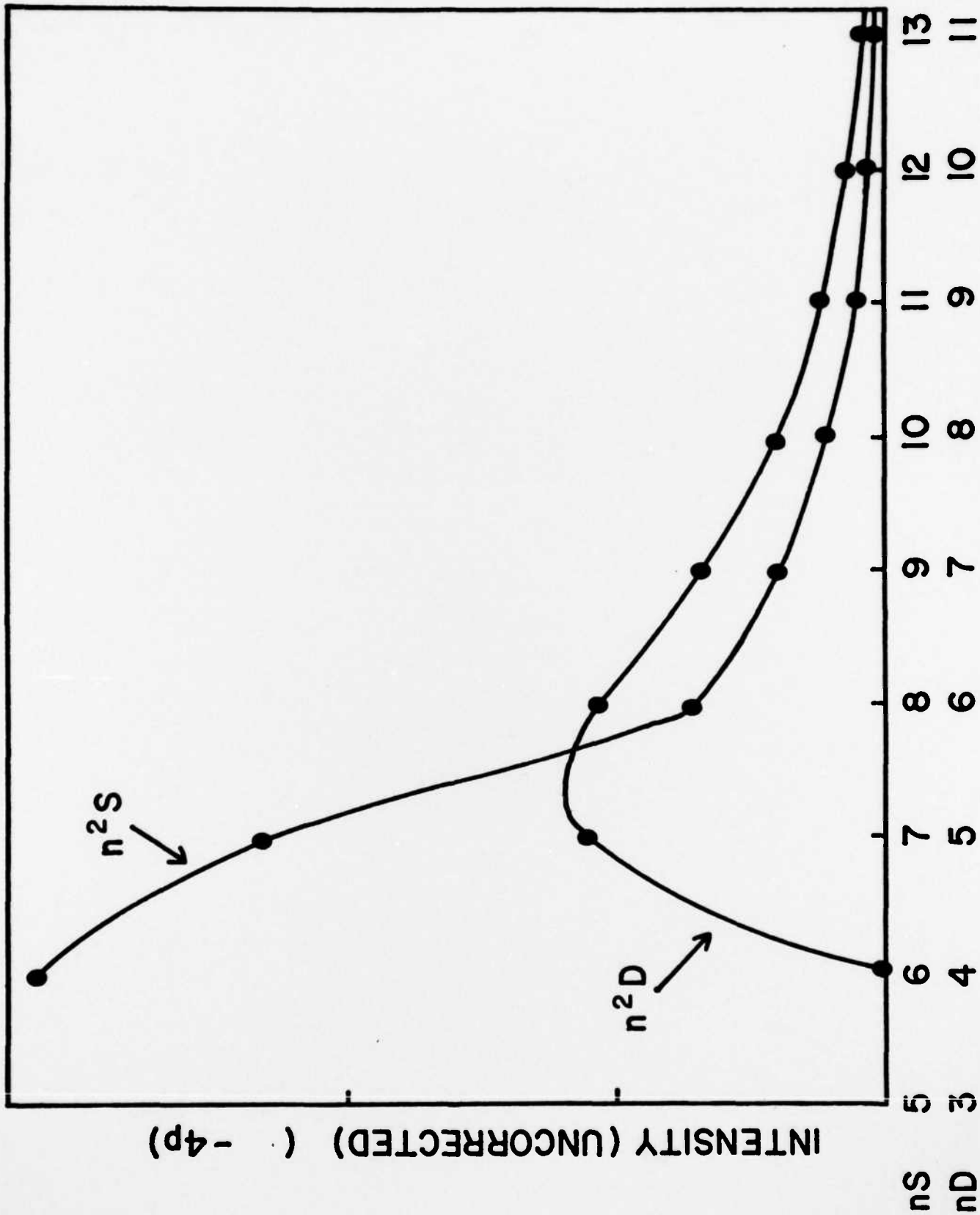

FIGURE 2

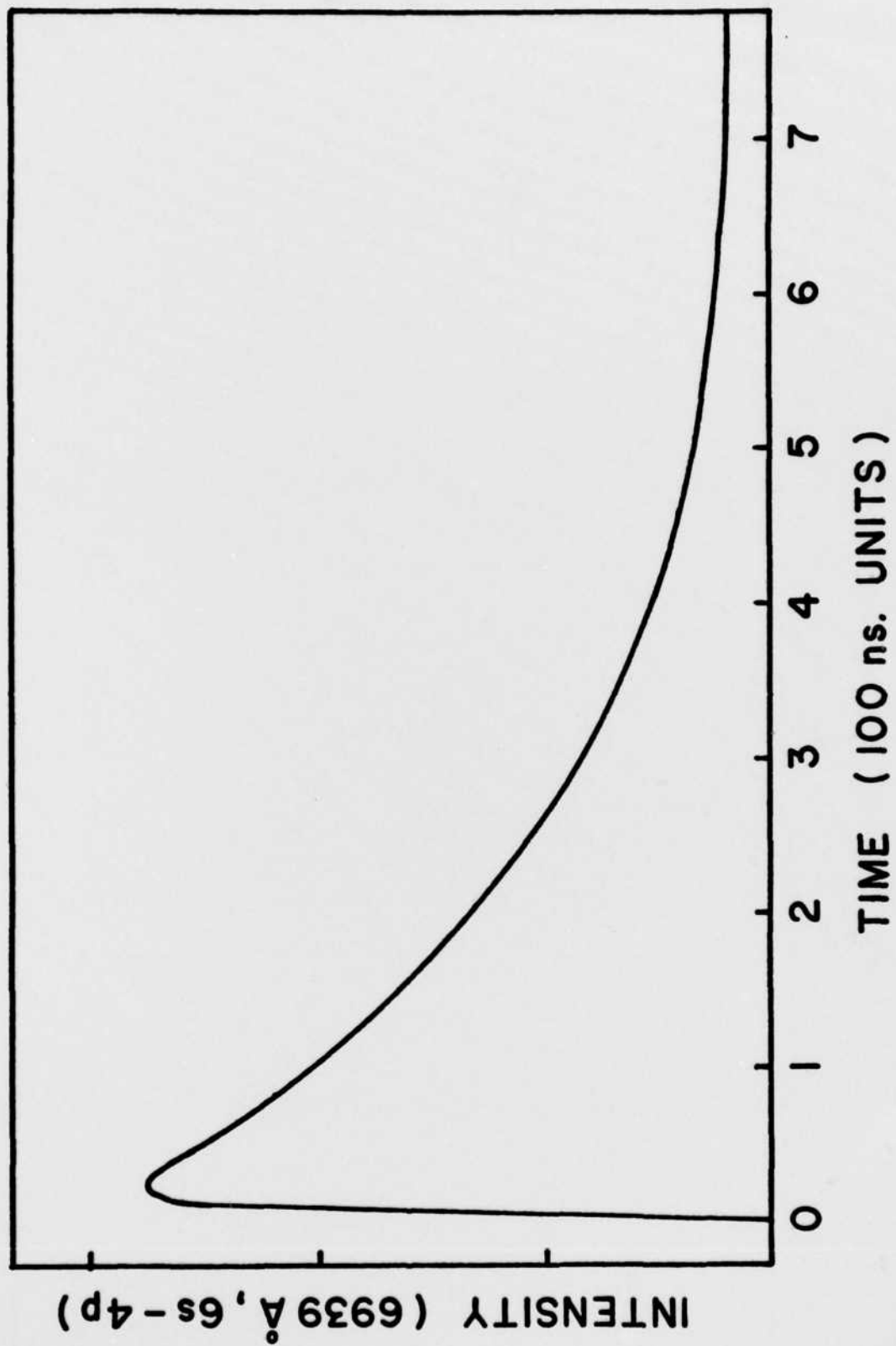

FIGURE 3

DATE
FILME