

AD-A047 265

NAVAL POSTGRADUATE SCHOOL MONTEREY CALIF

F/G 19/8

A HOMING TORPEDO. THE EFFECT OF THE TACTICAL SITUATION AND THE --ETC(U)

UNCLASSIFIED

NL

1 of 2  
ADA047265



AD A 0 47265

*2*

# NAVAL POSTGRADUATE SCHOOL

Monterey, California



DDC  
RECEIVED  
DEC 5 1977  
F

## THESIS

A HOMING TORPEDO.  
THE EFFECT OF THE TACTICAL SITUATION AND THE  
TORPEDO PARAMETERS ON THE TORPEDO EFFECTIVENESS  
by  
Anders Mjelde  
September 1977  
Thesis Advisor: A. R. Washburn

AD No. \_\_\_\_\_  
DDC FILE COPY

Approved for public release; distribution unlimited

Unclassified

SECURITY CLASSIFICATION OF THIS PAGE (When Data Entered)

REPORT DOCUMENTATION PAGE		READ INSTRUCTIONS BEFORE COMPLETING FORM
1. REPORT NUMBER	2. GOVT ACCESSION NO.	3. RECIPIENT'S CATALOG NUMBER
4. TITLE (and Subtitle) A HOMING TORPEDO. THE EFFECT OF THE TACTICAL SITUATION AND THE TORPEDO PARAMETERS ON THE TORPEDO EFFECTIVENESS.		5. TYPE OF REPORT & PERIOD COVERED Master Thesis September 1977
7. AUTHOR(s) Anders Mjelde		6. PERFORMING ORG. REPORT NUMBER
9. PERFORMING ORGANIZATION NAME AND ADDRESS Naval Postgraduate School Monterey, California 93940		8. CONTRACT OR GRANT NUMBER(s)
11. CONTROLLING OFFICE NAME AND ADDRESS Naval Postgraduate School Monterey, California 93940		10. PROGRAM ELEMENT, PROJECT, TASK AREA & WORK UNIT NUMBERS
14. MONITORING AGENCY NAME & ADDRESS (if different from Controlling Office) Naval Postgraduate School Monterey, California 93940		12. REPORT DATE Sep 1977
		13. NUMBER OF PAGES 12168 p.
		18. SECURITY CLASS. (of this report) Unclassified
		18a. DECLASSIFICATION/DOWNGRADING SCHEDULE
16. DISTRIBUTION STATEMENT (of this Report)  Approved for public release; distribution unlimited.		
17. DISTRIBUTION STATEMENT (of the abstract entered in Block 20, if different from Report)		
18. SUPPLEMENTARY NOTES		
19. KEY WORDS (Continue on reverse side if necessary and identify by block number) Torpedo, homing, sonar, simulation		
20. ABSTRACT (Continue on reverse side if necessary and identify by block number) When designing an active sonar homing torpedo, certain operational torpedo parameters such as speed, turn rate, etc. have to be decided upon. For a given homing torpedo, there must exist tactical guidelines of how to employ the torpedo, i.e. which firing position gives the best chance of a hit. This thesis attempts to gain some insight into the detection process during the torpedo run, as well as getting some indications of the relative importance of the different torpedo parameters and the tactical situations.		

DD FORM 1473  
1 JAN 73  
(Page 1)

EDITION OF 1 NOV 68 IS OBSOLETE  
S/N 0102-014-6601

Unclassified  
SECURITY CLASSIFICATION OF THIS PAGE (When Data Entered)

251450

Jmel

Unclassified

SECURITY CLASSIFICATION OF THIS PAGE (When Data Entered)

A simulation model was used in order to generate the data base for analysis. The results stress the importance of a good firing position as well as show how it is possible to counter a bad firing position by a high speed torpedo. They also point to the importance of having only one detection as requirement for target acquisition.

ACCESSION for	
NTIS	White Section <input checked="" type="checkbox"/>
DDC	Buff Section <input type="checkbox"/>
MANAGING	<input type="checkbox"/>
CLASSIFICATION	
BY	
DISTRIBUTION/AVAILABILITY CODES	
D	SPECIAL
A	

DD Form 1473  
1 Jan 73  
S/N 0102-014-6601

Unclassified  
SECURITY CLASSIFICATION OF THIS PAGE (When Data Entered)

Approved for public release; distribution unlimited

A HOMING TORPEDO  
THE EFFECT OF THE TACTICAL SITUATION AND THE TORPEDO  
PARAMETERS  
ON THE TORPEDO EFFECTIVENESS

by

Anders Mjelde  
Lieutenant-Commander  
Royal Norwegian Navy

Submitted in partial fulfillment of the  
requirements for the degree of

MASTER OF SCIENCE IN OPERATIONS RESEARCH

from the  
NAVAL POSTGRADUATE SCHOOL  
September 1977

Author:

*Anders Mjelde*  
-----

Approved by:

*Alan R. Washburn*  
-----  
Thesis Advisor

*RK Huttenlocher (for H.A. Titus)*  
-----  
Second Reader

*Michael J. Averigan*  
-----  
Chairman, Department of Operations Research

*A. Schradt*  
-----  
Dean of Information and Policy Sciences

## ABSTRACT

When designing an active sonar homing torpedo, certain operational torpedo parameters such as speed, turn rate, etc. have to be decided upon. For a given homing torpedo, there must exist tactical guidelines of how to employ the torpedo, i.e. which firing position gives the best chance of a hit. This thesis attempts to gain some insight into the detection process during the torpedo run, as well as getting some indications of the relative importance of the different torpedo parameters and the tactical situations. A simulation model was used in order to generate the data base for analysis. The results stress the importance of a good firing position as well as show how it is possible to counter a bad firing position by a high speed torpedo. They also point to the importance of having only one detection as requirement for target acquisition.

## TABLE OF CONTENTS

I.	INTRODUCTION.....	11
II.	NATURE OF THE PROBLEM.....	15
	A. DEFINITIONS.....	15
	B. ASSUMPTIONS.....	16
III.	PROBLEM SOLVING APPROACH.....	19
IV.	MODEL.....	21
	A. SEARCH.....	21
	B. DETECTION MODEL.....	23
	1. Detection Threshold.....	23
	2. Echo Intensity.....	23
	a. Lobe Characteristics.....	25
	b. Reduction in Intensity due to Range..	27
	c. Target Strength and Target Aspect....	27
	3. Detection Rule.....	36
V.	PRESENTATION OF DATA.....	37
	A. STOCHASTIC ELEMENTS.....	37
	B. TYPE OF PRINTOUT OF DATA AND RESULT.....	40
VI.	PARAMETRIC TORPEDO ANALYSIS.....	44
	A. OBJECTIVES.....	44
	B. OFFSETTING SONAR LOBE.....	45
	C. EFFECT OF TURN RATE.....	53
	D. EFFECT OF SWEEP ANGLE.....	59
	E. EFFECT OF BOTH SWEEP ANGLE AND TURN RATE.....	63
	F. EFFECT OF LOBE WIDTH.....	66
	G. EFFECT OF DETECTION RANGE.....	70
	H. COMBINED EFFECT OF LOBE WIDTH AND DETECTION RANGE.....	77
	I. EFFECT OF FIRING RANGE.....	82
	J. EFFECT OF TARGET SPEED.....	88
VII.	TACTICAL ANALYSIS.....	95

VIII. CONCLUSIONS.....	98
Appendix A: PRINT OUT OF SIMULATION PROGRAM.....	102
Appendix B: FLOW CHART FOR SIMULATION PROGRAM.....	120
Appendix C: DETAILED RUN PRINTOUT.....	166
LIST OF REFERENCES.....	167
INITIAL DISTRIBUTION LIST.....	168
LIST OF TABLES.....	7
LIST OF FIGURES.....	8

LIST OF TABLES

I	Variation in Offsetting Sonar Lobe.....	50
II	Variation in Torpedo Turn Rate.....	57
III	Variation in Sweep Angle.....	62
IV	Variation in Lobe Width.....	69
V	Variation in Detection Range.....	76
VI	Variation in both Lobe Width and Detection Range..	81
VII	Variation in Firing Range.....	87
VIII	Variation in Target Speed.....	93

## LIST OF FIGURES

1.	A Homing Torpedo.....	12
2.	Torpedo Triangle.....	18
3.	Structure of Computer Program.....	22
4.	Distribution of Lobes and Intensity.....	26
5.	Model of Target and Target Aspect.....	29
6.	Target Strength.....	32
7.	Distribution of Error in Target Data.....	39
8.	Example of Printout Heading.....	41
9.	Example of Printout Summary.....	42
10.	Offset Sonar Lobe.....	47
11.	Effect of Offsetting Sonar Lobe.....	48
12.	Effect of Turn Rate.....	54
13.	Comparison of Torpedoes with Different Turn Rates...	55
14.	Effect of Sweep Angle.....	60
15.	Comparison of Different Modification of a Torpedo...	64
16.	Comparison of Two Different Torpedoes.....	65
17.	Effect of Lobe Width.....	68
18.	Effect of Detection Range.....	71
19.	Comparison of Two Torpedoes with Change in Detection Range.....	74

20.	Variation in Effectiveness as a Function of Lobe Width and Detection Range.....	80
21.	Effect of Firing Range.....	83
22.	Comparison of Two Torpedoes with Change in Firing Range.....	85
23.	Effect of Target Speed.....	89
24.	Comparison of Two Torpedoes with Change in Target Speed.....	92
25.	Example of Tactical Guidelines.....	95

ACKNOWLEDGEMENT.

The author wish to gratefully express his appriciation to his advisor, Professor Alan R. Washburn, for his advice, encouragement and guidance in the preparation of this thesis.

Lastly, but not least, my wife, Karen, and my kids must be acknowledged for their patience and endurance in waiting and hoping for the completion of this thesis.

## I. INTRODUCTION

The following analysis examines the performance of a homing torpedo against a surface ship. A homing torpedo is described as a torpedo which is searching/snaking on each side of its main course. It is searching for a target by transmitting with its sonar and listening for an echo. Ref. Fig. 1. Passive searching torpedoes and homing torpedoes going in circles are not investigated in this paper.

The torpedo's performance is a function of many variables. These variables are divided into two groups;

- technical variables; speed, max torpedo run, sweep angle, technical detection range, lobe characteristics and turn rate.
- tactical variables ; firing range, attack angle, target speed, type of target and tactical detection range (sonar conditions).

No attempt is made to analyze the first group of variables; instead, technical variables used are those of present technology. We are assuming a 'standard homing torpedo' based upon homing torpedoes in operational use today [8]. This 'standard torpedo' assumes conventional warhead and active sonar transmission for detection., and is unguided.

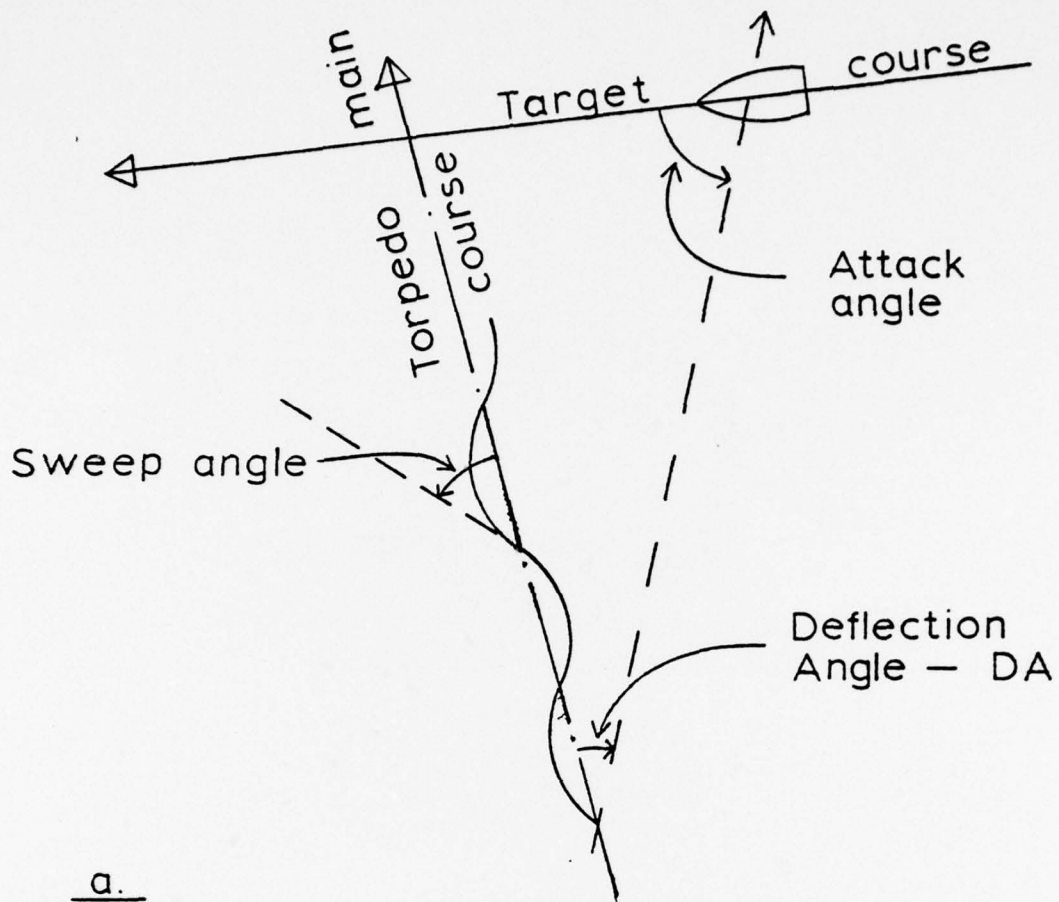

a.

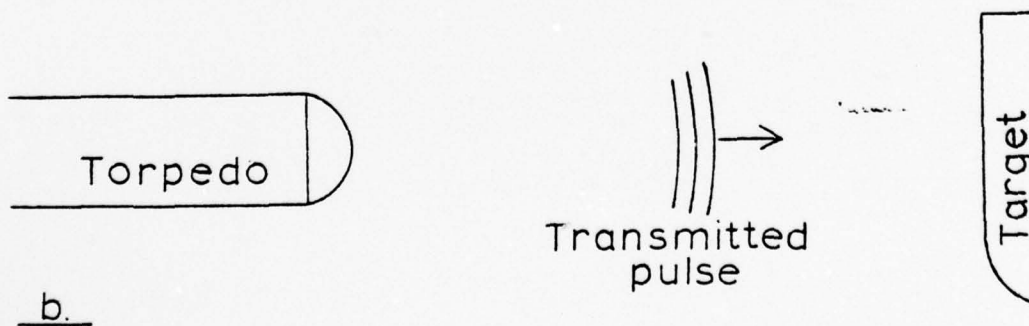

b.

Figure 1 - A HOMING TORPEDO

The technical variables (torpedo parameters) are in many ways interrelated. For example, the maximum detection range will determine the transmission rate, since the transmitted energy must have time to traverse out to maximum detection range and return as an echo before the next transmission, at least during the search phase.

At the same time the torpedo is transmitting, it is searching (changing course) for a target. In each transmission, the transmitted energy is focused within a narrow beam (lobe). During reception, the echo is confined within the same narrow beam (lobe). Concurrently, in the time between two transmissions the turning rate of the torpedo must be limited to ensure that the receiving lobe is not outside the direction from where an echo may return. Thus turn rate should be a function of detection range and the lobe pattern.

In order to maintain torpedo speed, the number of degrees of sweep on each side of the main course must be small. If the sweep angle is small, however, the width of the possible detection lane will be small as well, and consequently the detection probability might be reduced during transit. Also, a high torpedo speed creates a great change in torpedo position between each transmission. In this way the torpedo may scan outside a target in the sweep lane. In other words, the coverage density of the lobe may be low as a result of the high movement rate.

As we recognize the relationship between torpedo parameters, tactical variables and torpedo performance, we know that frequently within the naval establishment decisions have to be made with regard to torpedo parameters and tactical doctrines. In localizing and defining these relationships this analysis may be a tool in this

decisionprocess.

The measure of effectiveness by which different alternatives will be judged will be detection probability, by which is meant the probability that the torpedo's active sonar detects and begins to track the target. This probability will be measured by a digital computer simulation, construction of which was a major part of the author's effort in writing this thesis.

## II. NATURE OF THE PROBLEM

### A. DEFINITIONS

Lobe width is the number of degrees from the centerheading of the torpedo, until the first minimum in transmission intensity is reached. See Fig. 4.

Detection range is the range to the target when detection first occurs.

Technical detection range is the max detection range which is technically and reasonably possible considering power transmitted and lobewidth. It is the basis for determining the transmission rate.

Aspect is the angle measured from the positive direction of the longitudinal axis of the target to a line joining the centers of gravity of the target and the torpedo.

Attack angle is the aspect at the start of the torpedo run.

Sweep angle is the maximum number of degrees the torpedo will turn off the main course during search.

All dimensions are in meter, second, meter per second, degree, degree per second. Speed of the target and the torpedo are, however, always given in knots.

It is assumed that all firings are successful, and the torpedo will not deviate from its ordered/calculated course and speed.

All firings are made with a deflection angle; i.e. the torpedo is given a course to a predicted hitting point with the target.

#### B. ASSUMPTIONS

Not only in order to keep the problem tractable, but also because of modern torpedo development, only surface targets are considered. Previously within NATO, torpedo developments seemed to start as a development of an anti-submarine torpedo with later modifications in order to make the torpedo dual purpose. However, today there are some indications that the anti-surface ship requirement is coming into the development early in the planning process [7;8;9]. The entire problem is then kept in two dimensions. The vertical axis is not significant as we assume isovelocity condition, and we assume for simplicity that we have negligible surface effect.

Also, if the intensity of the echo is above detection threshold level, the target is detected with probability one. Probability of false contact is assumed to be zero.

The main purpose of a homing torpedo is to counter uncertainty in target data at firing and target maneuvering after firing.

For simplicity the following assumptions are made:

- the target remains on a steady course after firing.
- estimated target data is used in solving the deflection angle problem

- deflection angle(DA) is given by;

$$DA = \text{ARCSIN}((TAM \times \text{SIN}(ASP))/TO) \quad (2.1)$$

TAM = target estimated speed  
ASP = estimated aspect  
= (target estimated course) -  
(bearing to torpedo)  
TO = torpedo speed.

See Fig. 2.

The difference between the target data and the target estimated data are defined as errors in the target data. These errors are assumed to be random variates and are given as;

- target range error is uniformly distributed between  
- 15 % and + 15 % of actual target range
- target course error is uniformly distributed between  
- 15 and + 15 degrees
- target speed error is normally distributed with mean  
0 and standard deviation 3 knots.

These errors are assumed to cover errors in the fire control solution at the time of firing as well as non-radical maneuvering of the target during the torpedo run.

As shown in Eq. 2.1, estimated range does not enter into the calculation. Estimated range would only be used for some more complicated tactical situations as angled torpedo firing off the firing course of the firing unit. These situations are not covered in this study.

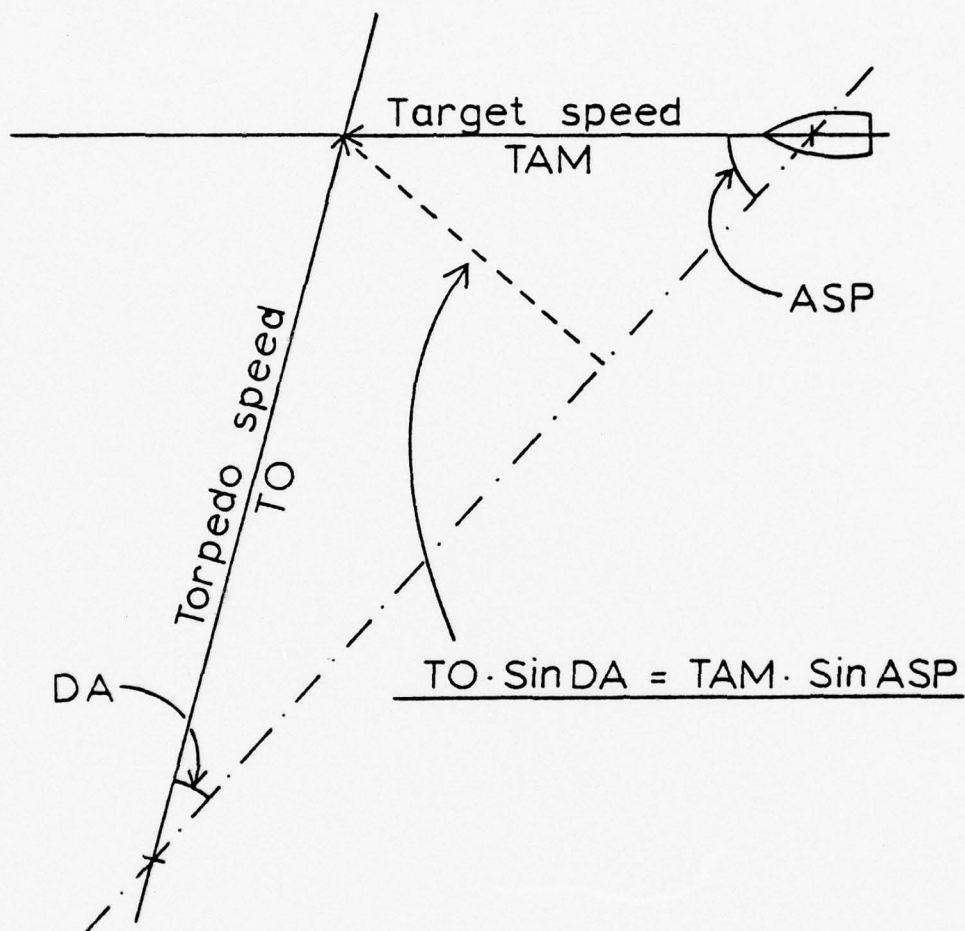

ASP — Estimated Attack angle  
 DA — Deflection angle

Figure 2 - TORPEDO TRIANGLE

### III. PROBLEM SOLVING APPROACH

At firing, the initial course of the torpedo is uniformly distributed between minimum course and maximum course (main course +/- a fraction of sweep angle).

Immediately after firing, the torpedo starts 'snaking'. During snaking, the torpedo is continuously changing course left or right out to the given sweepangle, then back past main course and out to sweepangle on the other side and so on. The torpedo is turning with the given turnrate. During the whole process, the torpedo is also transmitting and listening. Transmission interval(TTIME) is given by technical detection range as;

$$TTIME = 2 \times TEDEC / 1500 \quad \text{seconds} \quad (3.1)$$

where

TEDEC = technical detection range in meters.  
1500 = speed of sound in salt water, m/sec.

The torpedo run is conducted in steps. Every 0.5 seconds interval, all positions and courses are updated.

At each transmission; the relative bearing to target, and the target aspect are calculated in order to establish the intensity of the echo.

When a detection occurs, the following data is stored;

- detection range to the center of the target.

- detection range to the nearest part of the target.
- detection bearing (relative) to the center of the target.
- detection bearing(relative) to the nearest part of the target.
- target aspect.

In addition to the detection probability, the range at which the detection first occurs is also of interest. Therefore, we store these data at the first detection.

However, successive detections are also important. As part of the criterion for the decision of when to go from search-phase to attack-phase, the number of successive detections (with no non-detection between) may be employed. In real life there is always a positive probability of false detection. Even if we are not addressing the problem of false contact as such, we can cover the possibility by requiring the torpedo to have at least two successive detections before going into attack-phase. Accordingly, we store also the previously listed data at the second successive detection (two immediately following detections), at the third and so on, up to and including 5 successive detections. This listing of detections will give an indication of the decrease in detection probability if a large number of successive detections before going into attack-phase is required in order to decrease the probability of false contacts.

#### IV. MODEL

##### A. SEARCH

For simulating the torpedo search, a Fortran IV simulation program was developed.

The program was divided into;

- Main program, including generation of statistics and print out of summary after all the runs were completed.
- Subroutine PARMET for setting tactical situation and torpedo parameters.
- Subroutine FIRING which calculates estimated target data, and the deflection angle.
- Subroutine POSIS which calculates the torpedo course, and torpedo and target positions at each time step.
- Subroutine DETECT which checks if the target is detected and if so, store detection data.

See Fig. 3.

See Appendix A and Appendix B.

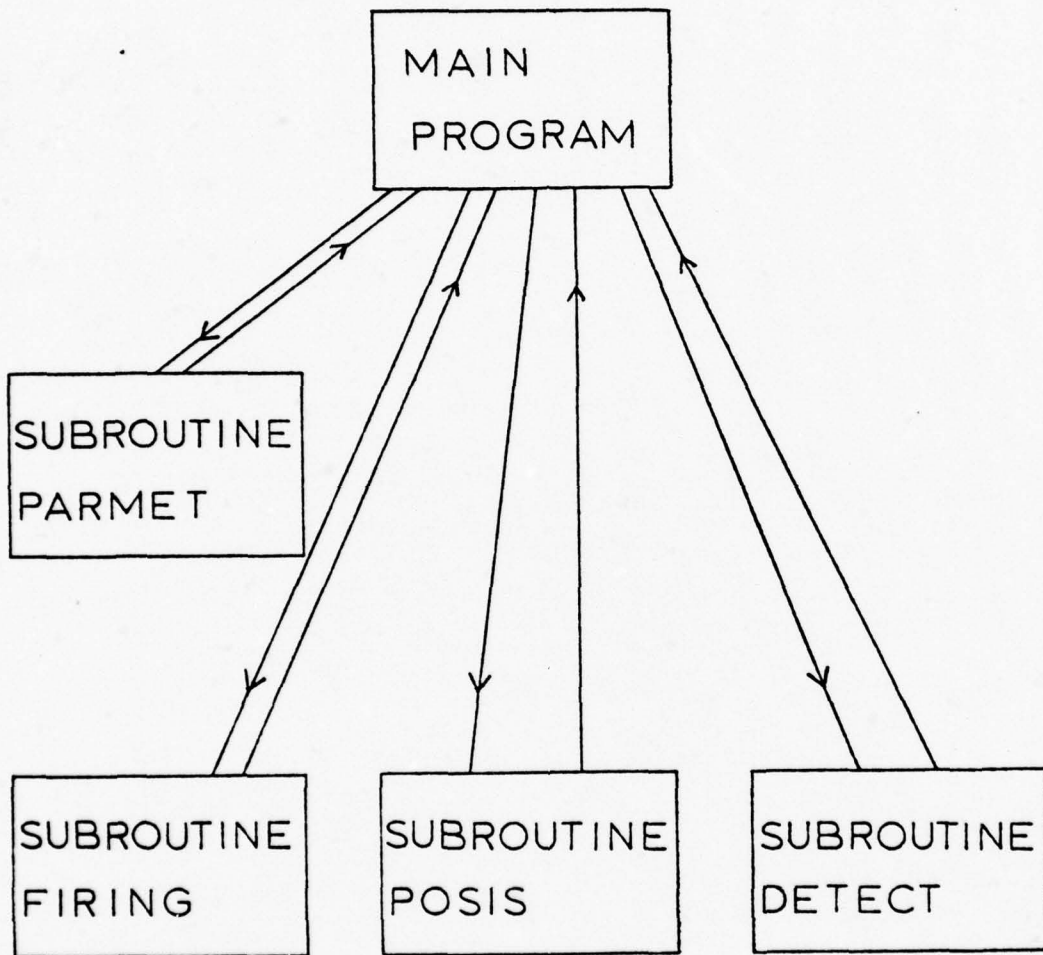

Figure 3 - STRUCTURE OF COMPUTER PROGRAM

## B. DETECTION MODEL

A contact occurs when the acoustic energy-pulse generated at the transducer and reflected from the target as an echo, is at or above threshold level. In the following discussion we assume that the contact meets the tactical requirement, and accordingly we use the term detection.

### 1. Detection Threshold

Deciding if a detection occurs is a function of detection threshold(signal to noise ratio), the range to the target, the target strength and the relative bearing to the target, given a level of radiated intensity.

The detection threshold for a torpedo is a function of design and technological sophistication of the torpedo. Without making any assumption about these variables in the model, we start with a given technical detection range, a 'standard' target, and calculate intensity of echo at that range for target aspect equal to 90 degrees(maximum target strength) and relative bearing to the target equal to zero degrees. This echo intensity is then the detection threshold for every transmission during a run. If any echo intensity is above the detection threshold, it is detected; if below the detection threshold, it is not detected.

### 2. Echo Intensity

In calculating echo intensity we must separately investigate the important factors, which are transducer

gain, lobe characteristic, transmission loss and target strength. The model used is described below.

a. Lobe Characteristics

The transducer has a main lobe and many sidelobes as a function of the transducer's gain and relative bearing. Urlick [6;51-57] discusses some of the different types of beam pattern (lobes), and the following mathematical model was developed and found to give an acceptable pattern;

$$G(\theta) = G_0 \left| \frac{\text{SIN}(x \pi)}{x \pi} \right| \text{COS}(\theta/2) \quad (4.1)$$

where

$$x = \theta/\theta_0 \quad (4.2)$$

and

$G_0$  = maximum gain  
 $\theta$  = relative bearing  
 $\theta_0$  = lobe width.

This model will produce the gain-pattern as shown in fig. 4.

Lobe width = 20°

Lobe distribution

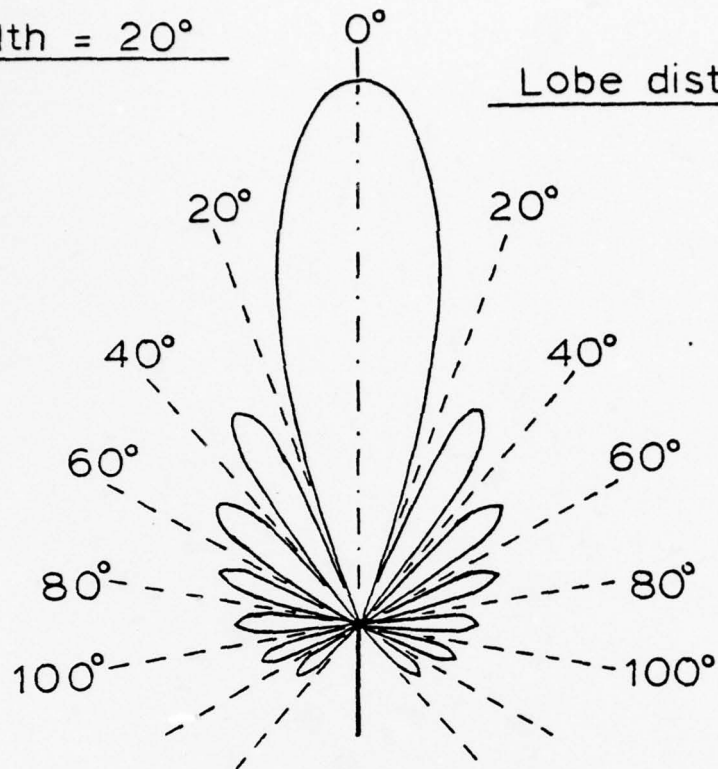

Intensity distribution

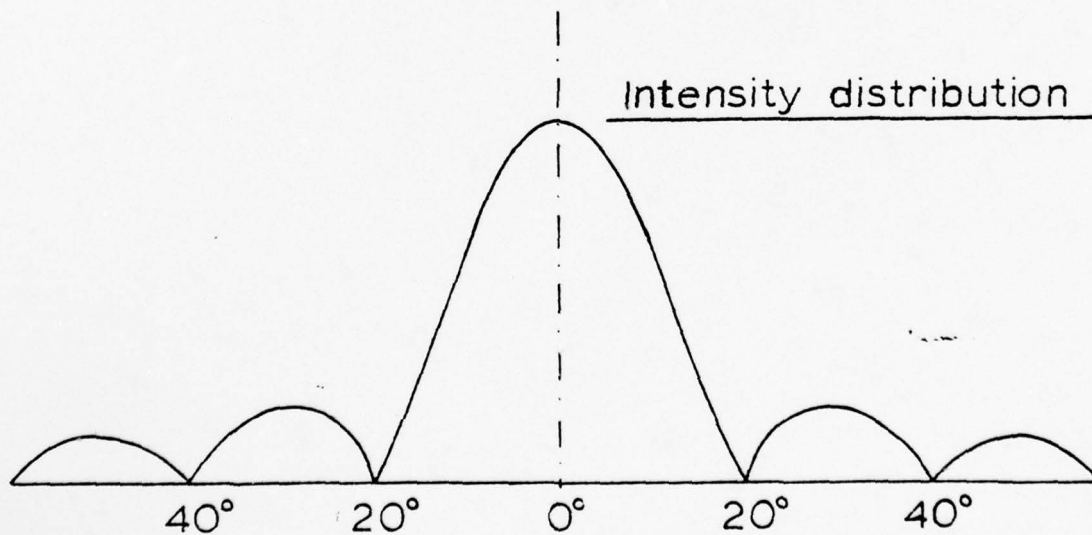

Figure 4 - DISTRIBUTION OF LOBES AND INTENSITY

b. Reduction in Intensity due to Range

Primarily, the reduction is due to two effects; spherical spreading and absorption.

Spherical spreading is a known function, but absorption is dependent upon transmission frequencies, water, salinity etc. In order to simplify the model and since spherical spreading has the greatest effect, only the spherical spreading for reduction in intensity is considered. This reduction in a one way propagation is given by;

$$I = I_0 / R^2 \quad (4.3)$$

where

$I_0$  = radiated intensity at one meter

$I$  = intensity at range  $R$ .

$R$  = range in meters.

c. Target Strength and Target Aspect

When the transmitted energy pulse hits the target, some of the energy is reflected back to the transducer. The echo intensity is a function of the shape and dimension of the target, type of reflective material and aspect.

It should be noted that the notion of target strength represents the ratio between target cross section and the surface of a sphere of radius 1 meter, or if in dB, 10 times the log of this ratio; base 10. In most references, the target strength or the target cross section is given abeam of the target, see [5;97],[6;274], without presenting the cross section as a function of the aspect. Urick [6;282,283] gives, however, as figures, an indication

of how the target strength (in dB) varies with the aspect. Cox[3;60] states that it will vary between 10 and 25 dB. All measurements in dB in the two references are relative to 1 yard as unit for range. Urick[6;283-286] indicates that his reference (as given in the figures) will not change in any considerable degree with changes in frequencies (20-60 KHz) or for different targets (submarines/surface ships).

Assuming a torpedo with transmitting frequency between 50 and 60 KHz, we get a wavelength varying between 2.5 and 3.0 cm (0.025 - 0.03 meters). As any reflection from a target is mostly determined by target form, size, aspect and wavelength, we may use a model from radar theory in our next step. The justification for this use is that in radar theory we are working in the same area of wavelength and target dimension as an active sonar for a homing torpedo.

Crispin and Siegel [4;86] give for target cross section a model for an ellipsoid where the incident angle (target aspect) is a variable. The relationship is as follows;

$$\sigma = \frac{\pi \cdot a^2 \cdot b^2 \cdot c^2}{(a^2 \cdot \sin^2 \theta \cdot \cos^2 \phi + b^2 \cdot \sin^2 \theta \cdot \sin^2 \phi + c^2 \cdot \cos^2 \theta)} \quad (4.4)$$

a, b, c being half axes of the ellipsoid.  
Ref. Fig. 5.

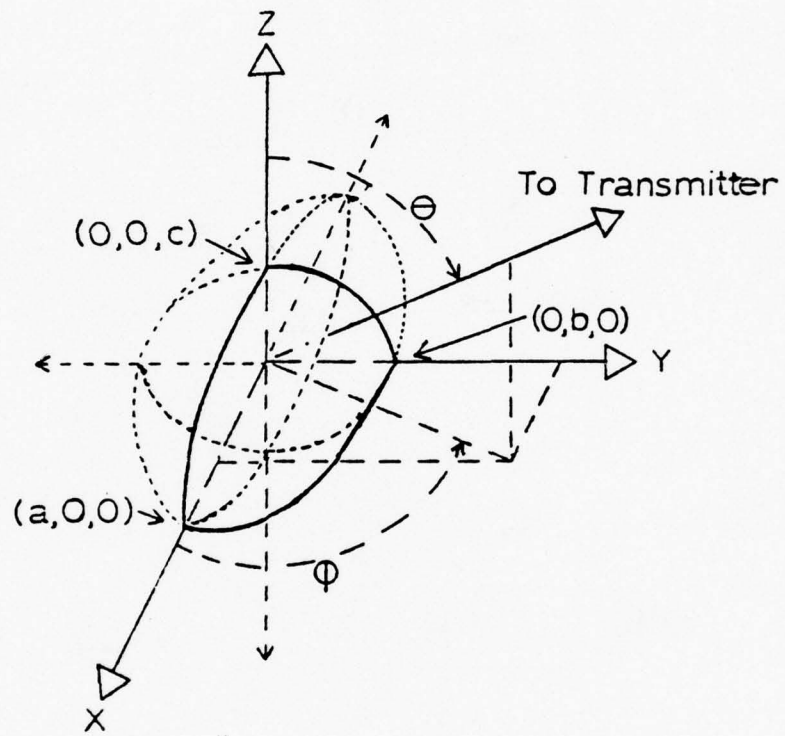

Figure 5 - MODEL OF TARGET AND TARGET ASPECT

As we assume that the transmitting pulse is always in the horizontal plane,  $\theta$  is 90 degrees, which gives us;

$$\sigma = \frac{\pi \cdot a^2 \cdot b^2 \cdot c^2}{(a^2 \cdot \cos^2 \phi + b^2 \cdot \sin^2 \phi)^2} \quad (4.5)$$

$\phi$  = aspect.

Urick [6;275] gives for target section a model for abeam or ahead cases, which is;

$$t = \sigma / (4\pi) = (b \cdot c / 2 \cdot a)^2,$$

identical with Eq. 4.5. Note that Eq. 4.5 is an expression for the target cross section.

Haslett [5;139] gives for the target cross section a model for both ahead and abeam cases. His model equals Eq. 4.5 times a factor  $\underline{R}^2$ , where  $\underline{R}$  is acoustic reflectivity coefficient (per cent) = 94.

The advantage of using Eq. 4.5 is that it gives the target cross area as a continuous function of the target aspect. For our model we will only use the lower part of the ellipsoid to simulate the ship hull below the water line.

Combining Eq. 4.5 and acoustic reflectivity coefficient we get the following model for the target cross section;

$$\sigma = \frac{\pi \cdot a^2 \cdot b^2 \cdot c^2 \cdot \underline{R}^2}{(a^2 \cdot \cos^2 \phi + b^2 \cdot \sin^2 \phi)^2} \quad (4.6)$$

With reference to Urick's figures [6;283] where the pattern of the target strength is given as a function of

aspect in Fig. 9.13, and reproduced in this analysis as Fig. 6.a, we still have not obtained a model which gives the same type of pattern. By applying the following scaling factor to Eq. 4.6 we have approximated his information:

$$U = (0.251635 \cdot \phi^2 - 0.18555 \cdot \phi + 0.0365 \cdot \text{SIN}(3 \cdot (\phi + 0.17453)) + 0.015 \cdot \phi^2 \cdot \text{SIN}(9 \cdot \phi/2))^{-1} \quad (4.7)$$

We then have as the target cross section in our model the following expression;

$$\underline{\sigma} = \sigma \times U \quad (4.8)$$

where  $\sigma$  and  $U$  are as previously shown.

Fig. 6.a and Fig 6.b shows an 'ideal' pattern and a model pattern. The figures given by Urick are for 1 yard as reference distance, but have been converted to 1 meter reference distance in Fig. 6. To go from dB(yard) to dB(meter), we subtract 0.78 dB. The dB as given in this analysis are all with 1 meter as reference distance.

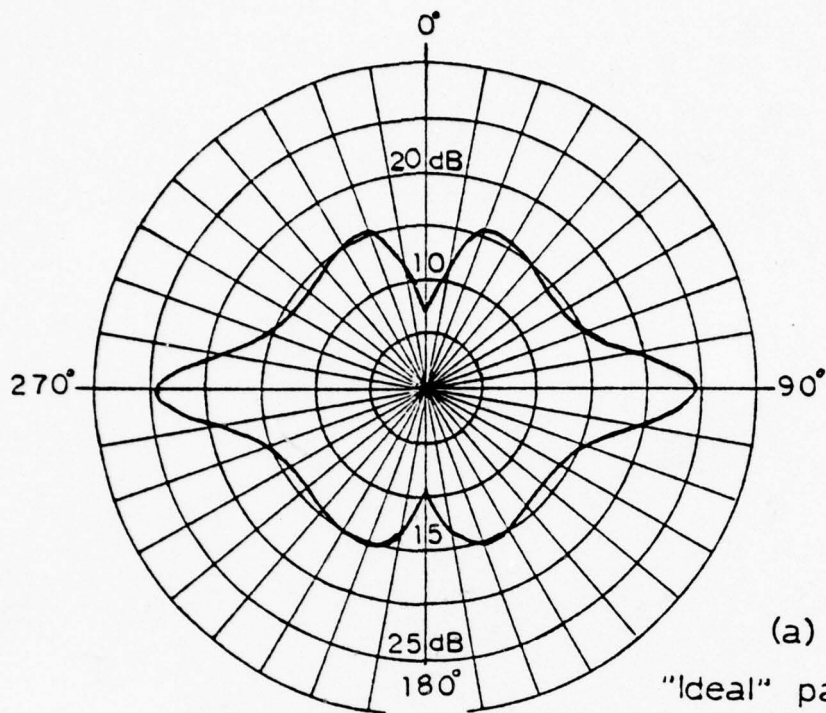

(a)  
"Ideal" pattern for target strength  
 ref 1m

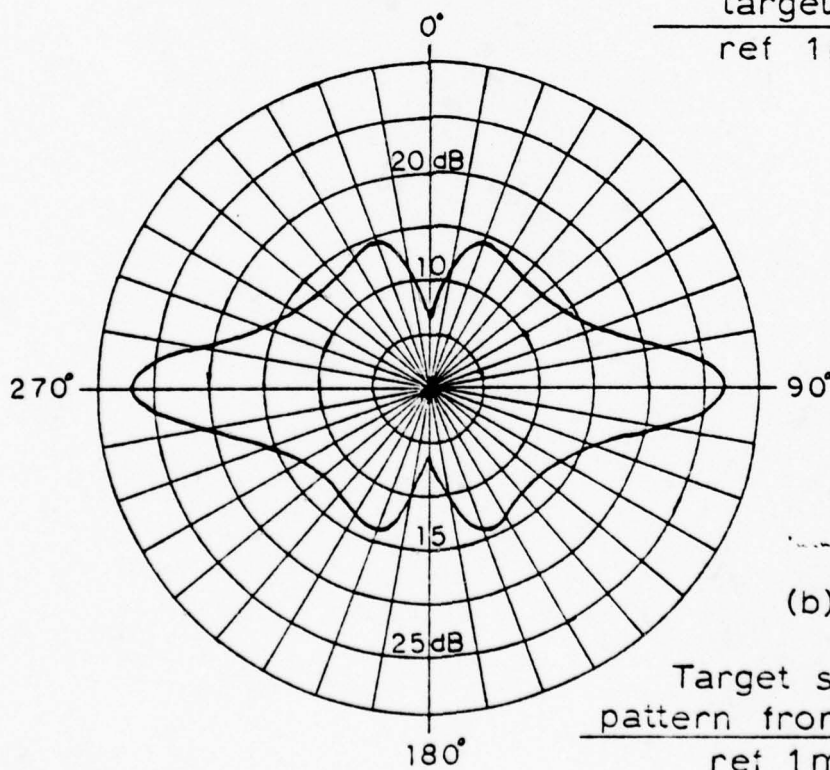

(b)  
Target strength pattern from model  
 ref 1m

Figure 6 - TARGET STRENGTH

The active sonar equation is;

$$P = \frac{P_0 \cdot G_t \cdot \sigma \cdot G_r \cdot \lambda^2}{(4 \cdot \pi)^3 \cdot R} \quad \text{Watts} \quad (4.9)$$

$P$  = power received

$P_0$  = power transmitted

$G_t$  = gain transmitting, ref Eq. (4.1)

$\sigma$  = target cross section, ref Eq. (4.8)

$G_r$  = gain receiving, ref Eq. (4.1)

$\lambda$  = wavelength in meters.

$R$  = range to target in meters.

This may be rewritten into an expression of power received as a function of the variables of the different terms;

$$P = K \frac{\left| \frac{\text{SIN}(X_t \cdot \pi)}{X_t \cdot \pi} \right|^2 \cdot a^2 \cdot b^2 \cdot c^2 \cdot R^2 \cdot \left| \frac{\text{SIN}(X_r \cdot \pi)}{X_r \cdot \pi} \right|^2}{R \cdot (a \cdot \text{COS } \phi + b \cdot \text{SIN } \phi)^2} \quad (4.10)$$

$K$  = the product of all the constants in the terms.

For more detailed discussion about gain, transmission loss and reflection (target cross section), see [1;110-111] and [6;29,94,263].

We can now calculate the minimum power level for detection by setting:

$R_t$  = technical detection range

$X_t$  = 0 degree

$X_r$  = 0 degree

$\phi$  = 90 degrees

and we get

$$P_{\min} = K \frac{a^2 \cdot b^2 \cdot c^2 \cdot R_t^2 \cdot U}{R_t^4 \cdot (b)^2} \quad (4.11)$$

and by substituting for U

$$P_{\min} = K \frac{a^2 \cdot b^2 \cdot c^2 \cdot R_t^2 \cdot 3.08657}{R_t^4 \cdot (b)^2} \quad (4.12)$$

a, b and c are the dimension of the target used in the model.

We assume a 'standard' target, length 100 meters, beam 15 meters and draught 4 meters, i.e.

a = 100

b = 15

c = 4.

There will be a detection if  $P/P_{\min} > 1$ . Note that  $P/P_{\min}$  does not depend on K, into which radiated power and transducer gains have been included. The technical detection range  $R_t$  is an operationally meaningful surrogate

for these parameters. The ratio  $P/P_{\min}$  will be called the "intensity fraction".

### 3. Detection Rule

Any intensity-fraction calculated during a transmission which is greater than 1 is a detection. However, to improve the model at close ranges, the following modification has been made for gain variation due to relative bearing.

At close ranges, the relative bearing to target can alter considerably from bow to stern. Therefore, the intensity in the pulse will differ along the target. To average this intensity both for the radiated pulse and for the echo, the model calculates relative bearing to the target bow, center and stern, calculates the corresponding gain factor for each bearing, and finds the arithmetic mean of these gain factors. These two average gainfactors (transmitting and receiving) are then used in the calculation of echo intensity.

The model does not recognize a detection unless the tactical situation makes it possible to maintain contact with the target for some time. To be precise, the following conditions must be present;

- torpedo turn rate higher than bearing rate
- closing speed must be positive.
- target must have 2 knots doppler.

## V. PRESENTATION OF DATA

### A. STOCHASTIC ELEMENTS

In the previous description of the model, the following input values are stochastic;

- error in target speed
- error in target course
- error in target range
- initial torpedo course(not main course).

The primary stochastic effects on the torpedo performance are identified as errors in target speed and course, since these two variables are the only stochastic ones used in computing the torpedo main course. The first problem to be solved was then how to design the run series in order to reduce variance in result at the same time as keeping the result unbiased.

It was found that instead of using a complete randomized design (random variates); we could deterministically section the probability range 0.0 - 1.0 for the two important random variables, using the inverse probability transformation to get variates, and then run the number of runs required to cover all combinations of variates.

Some preliminary simulation runs were done in three

versions; complete randomized and independent; with antithetic reduction technique (sectioning); and the previously described procedure. The number of runs needed in order to keep the variance low for the result was considerably higher for the first two versions. Accordingly, we selected the previously described procedure. It was found that a series of 150 runs was sufficient in order to give a reasonable accuracy in detection probability and at the same time keeping the total CPU time for a series of runs acceptably low. The 150 run series was established by dividing the range of probability of target speed errors into 15 equally spaced sections; and the range of probability of target course errors into 10 equally spaced sections. Each section boundary point was by inverse probability transformation converted into a variate. Bearing in mind that speed errors are normally distributed and course errors are uniformly distributed, all combinations of target data error are plotted in Fig. 7.

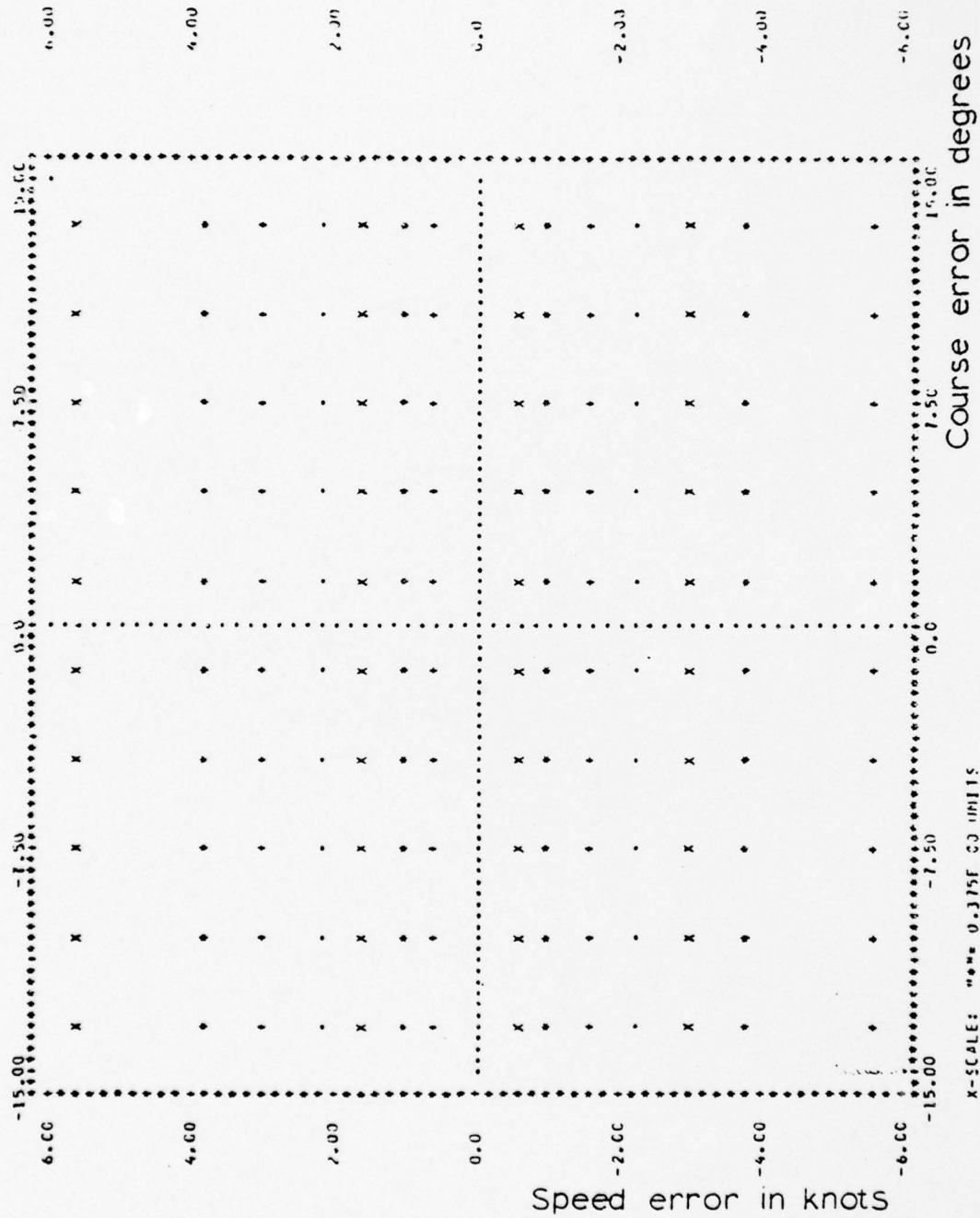

Figure 7 - DISTRIBUTION OF ERROR IN TARGET DATA

## B. TYPE OF PRINTOUT OF DATA AND RESULT

Each series of 150 runs produces a printout as shown. The heading of the printout gives the tactical situation and the torpedo parameters in the given run series. Also, the printout gives the sweep lane, which is the width of the lane where the torpedo has swept through by its sonar lobe. The coverage ratio gives an indication of the fraction of the lobe, which is covered twice; i.e. how much the lobe is being offset from its previous position by change in the torpedo course. The question of offsetting the sonar lobe, about which information is given in the printout, is discussed later in Ch. VI.

Ref. Fig. 8.

For each run, the following are output: target data, torpedo deflection angle, torpedo main course, target and torpedo grid position at end of run, duration of torpedo run and length of torpedo run.

After all runs in a series are completed, a summary is given.

Ref. Fig. 9.

The summary gives detection probability for a single detection, 2 successive detections, up to 5 successive detections. Also mean detection range, standard deviation of detection range, mean aspect, mean detection bearing relative to center bearing of sonar lobe and relative to main course are given.

Lastly, the detection range, the relative bearing to the center of the target and to the closest part of the target

TACTICAL SITUATION WHEN FIRING TORPEDO PARAMETERS  
 RANGE ATTACK TARGET TARGET TORPEDO TARGET  
 ANGLE COURSE SPEED SPEED RANGE SPEED ANGLE WIDTH TURN SWEEP COVERAGE  
 3000. -90.0 270.0 19.0 750.0 40.0 30.0 20.0 18.0 1149.1 0.55  
 SCAR MAIN LOBE OFF-SET FROM CENTER BEARING 0.0 TIMES DEFLECTION ANGLE

RUN NO	EST OF TARGET COURSE	SPEED	RANGE	TORP DA	TORP COURSE	TORP COORD X	TORP COORD Y	TARGET COORD X	TARGET COORD Y	RUN STOP	TORP RUN
1	256.5	12.4	3345.	-17.5	342.5	14037.	15061.	13488.	15000.	163	3360.
NO DETECTION	MADE	DURING	THIS RUN								
2	256.5	14.2	2792.	-20.1	339.9	13825.	15199.	13394.	15000.	173	3570.
NO DETECTION	MADE	DURING	THIS RUN								
3	256.5	15.1	2990.	-21.5	338.5	13755.	15173.	13394.	15000.	178	3570.
NO DETECTION	MADE	DURING	THIS RUN								
4	256.5	15.8	2912.	-22.5	337.4	13695.	15149.	13394.	15000.	178	3570.
NO DETECTION	MADE	DURING	THIS RUN								
5	256.5	16.4	3232.	-23.5	336.5	13634.	15122.	13394.	15000.	178	3570.
NO DETECTION	MADE	DURING	THIS RUN								
6	256.5	17.0	3392.	-24.4	335.6	13597.	15106.	13394.	15000.	178	3570.
7	256.5	17.5	2922.	-25.2	334.8	13450.	15259.	13299.	15000.	183	3780.
8	256.5	18.0	3438.	-25.9	334.1	13434.	15251.	13299.	15000.	189	3780.
9	256.5	18.5	3312.	-26.7	333.3	13366.	15218.	13299.	15000.	189	3780.
10	256.5	19.0	2931.	-27.5	332.5	13342.	15206.	13299.	15000.	189	3780.
11	256.5	19.6	2948.	-28.4	331.6	13269.	15167.	13299.	15000.	189	3780.
12	256.5	20.2	3394.	-29.4	330.6	13241.	15151.	13299.	15000.	189	3780.
13	256.5	20.9	2897.	-30.5	329.5	13154.	15101.	13299.	15000.	189	3780.
NO DETECTION	MADE	DURING	THIS RUN								
14	256.5	21.8	2913.	-32.1	327.9	12977.	15229.	13205.	15000.	199	3990.
NO DETECTION	MADE	DURING	THIS RUN								
15	256.5	23.0	3230.	-35.0	325.0	12813.	15119.	13205.	15000.	199	3990.
NO DETECTION	MADE	DURING	THIS RUN								
16	256.5	12.4	3430.	-17.7	342.3	14033.	15058.	13488.	15000.	163	3360.
NO DETECTION	MADE	DURING	THIS RUN								
17	256.5	14.2	3277.	-20.4	339.6	13816.	15195.	13394.	15000.	173	3570.
NO DETECTION	MADE	DURING	THIS RUN								
18	256.5	15.1	3394.	-21.8	339.2	13733.	15163.	13394.	15000.	173	3570.
NO DETECTION	MADE	DURING	THIS RUN								
19	256.5	15.8	3362.	-22.9	337.1	13670.	15137.	13394.	15000.	173	3570.
NO DETECTION	MADE	DURING	THIS RUN								
20	256.5	16.4	3282.	-23.8	336.2	13626.	15118.	13394.	15000.	178	3570.
21	256.5	17.0	2964.	-24.7	335.3	13581.	15098.	13394.	15000.	178	3570.
22	256.5	17.5	2791.	-25.5	334.5	13460.	15263.	13299.	15000.	189	3780.
23	256.5	18.0	2943.	-26.3	333.7	13389.	15229.	13299.	15000.	199	3780.
24	256.5	18.5	3260.	-27.1	332.9	13369.	15218.	13299.	15000.	189	3780.
25	256.5	19.0	2850.	-27.9	332.1	13325.	15196.	13299.	15000.	189	3780.
26	256.5	19.6	3338.	-28.3	331.2	13250.	15155.	13299.	15000.	189	3780.
27	256.5	20.2	2790.	-29.7	330.3	13198.	15127.	13299.	15000.	189	3780.
NO DETECTION	MADE	DURING	THIS RUN								
28	256.5	20.9	3384.	-30.9	329.1	13132.	15088.	13299.	15000.	189	3780.
NO DETECTION	MADE	DURING	THIS RUN								
29	256.5	21.8	2904.	-32.5	327.5	12957.	15213.	13205.	15000.	199	3990.

Figure 8 - EXAMPLE OF PRINTOUT HEADING

41 BEST AVAILABLE COPY

140	283.5	16.4	295.7	-23.5	336.5	13630.	15121.	13194.	15000.	178	4570.
141	283.5	17.0	2891.	-24.4	335.6	13690.	15107.	13194.	15000.	178	3570.
142	283.5	17.5	2978.	-25.2	336.8	13554.	15087.	13394.	15000.	178	3570.
143	283.5	18.0	3231.	-25.9	334.1	13435.	15250.	13249.	15000.	189	3780.
144	283.5	18.5	2908.	-26.7	333.3	13366.	15218.	13299.	15000.	189	3780.
145	283.5	19.0	2985.	-27.5	332.5	13318.	15193.	13299.	15000.	189	3780.
146	283.5	19.6	3321.	-28.4	331.6	13295.	15180.	13299.	15000.	189	3780.
147	283.5	20.2	2915.	-29.4	330.6	13217.	15138.	13295.	15000.	189	3780.
148	283.5	20.9	3379.	-30.5	329.5	13159.	15100.	13299.	15000.	189	3780.
149	283.5	21.8	2815.	-32.1	327.9	12978.	15225.	13205.	15000.	199	3950.
150	283.5	23.6	3380.	-35.0	325.0	12811.	15117.	13205.	15000.	199	3950.

SUMMARY OF RESULT AFTER 150 RUNS  
 PROBABILITY OF DETECTION 0.4933  
 ONE SUCCESSIVE DETECTION 0.4267  
 TWO SUCCESSIVE DETECTIONS 0.2933  
 THREE SUCCESSIVE DETECTIONS 0.2467  
 FOUR SUCCESSIVE DETECTIONS 0.1933  
 FIVE SUCCESSIVE DETECTIONS 0.1433

AVERAGE EFFICIENCY ANGLE : -26.5123

LINE	REAR	RANGE	SUCCESSIVE DETECTION	ASPECT	BEAR	RESULT	CENTER	OF	TARGET	TWO	SUCCESSIVE	DETECTIONS	ASPECT	REAR	CLUS	THREE	SUCCESSIVE	DETECTIONS	ASPECT	REAR	CLUS	AVERAGE	DEF BEARING	DEF BEARING	AVERAGE	DEF BEARING	DEF BEARING
0.0	0.0	0.0	0.0	0.0	0.0	0.0	0.0	0.0	0.0	0.0	0.0	0.0	0.0	0.0	0.0	0.0	0.0	0.0	0.0	0.0	0.0	106.5719	12.2624	12.2624	106.5719	12.2624	
0.0	0.0	0.0	0.0	0.0	0.0	0.0	0.0	0.0	0.0	0.0	0.0	0.0	0.0	0.0	0.0	0.0	0.0	0.0	0.0	0.0	0.0	104.3547	21.5057	21.5057	104.3547	21.5057	
0.0	0.0	0.0	0.0	0.0	0.0	0.0	0.0	0.0	0.0	0.0	0.0	0.0	0.0	0.0	0.0	0.0	0.0	0.0	0.0	0.0	0.0	99.5117	104.6071	104.6071	99.5117	104.6071	
0.0	0.0	0.0	0.0	0.0	0.0	0.0	0.0	0.0	0.0	0.0	0.0	0.0	0.0	0.0	0.0	0.0	0.0	0.0	0.0	0.0	0.0	80.5211	99.3172	99.3172	80.5211	99.3172	
0.0	0.0	0.0	0.0	0.0	0.0	0.0	0.0	0.0	0.0	0.0	0.0	0.0	0.0	0.0	0.0	0.0	0.0	0.0	0.0	0.0	0.0	44.6235	44.6235	44.6235	44.6235	44.6235	

Figure 9 - EXAMPLE OF PRINTOUT SUMMARY

BEST AVAILABLE COPY

at detection (relative to present torpedo course), and the target aspect at detection are printed for each run for a single detection, 2 successive and 3 successive detections.

It also should be noted that it is possible to get a more detailed printout for each run by setting IPRINT = 0 in the main program (main program statement 035).

Ref. Appendix D. for example of detailed run printout.

From the printout data, it is possible to study different aspects of the detection process as well as to generate distributions of detection range, aspect, bearing etc.

## VI. PARAMETRIC TORPEDO ANALYSIS

### A. OBJECTIVES

The following approach was used:

The torpedo speed, the technical detection range and the lobe width were assumed to characterize a torpedo type. Within the type, it was possible to change the turn rate and the sweep angle.

A tactical situation was characterized by the attack angle, the target speed and the firing range.

The following questions were investigated:

- Can a torpedo be improved by offsetting its sonar lobe from the torpedo heading ?  
Rephrased; it may be asked, is the sonar lobe searching in the right direction (most likely area) by pointing straight ahead along the torpedo course ?
- How do turn rate and sweep angle affect a torpedo's MOE ?
- How are the different torpedo types related to each other with regard to detection probability (MOE) ?

In the analysis, we started with a reasonable tactical situation; target speed 18 knots, range 3000 meters, technical detection range 750 meters. Initially, we changed the attack angles.

With regard to torpedoes, we started with three types of

torpedoes; 24 knots, 32 knots and 40 knots; all with 20 degree lobe width, 6 degree per second turn rate and 30 degree sweep angle.

#### B. OFFSETTING SONAR LOBE

The hypothesis was that when a torpedo is fired on a deflection angle course, the sonar lobe should be most effective if it scans across the bearing to the target. Or, the sonar lobe should be offset equal to deflection angle (DA). Ref. Fig. 10.

It was found that offsetting had a positive effect when attacking from ahead of target.

Ref. Fig. 11.a. and b.

But from about 30 degree to about 110 degree attack angle the effect was negative. If more than 110 degree attack angle, there was no effect.

In analyzing the fraction of offsetting, we analyzed the case of 30 degree and 60 degree attack angle. There seemed to be no effect from 0.0 to 0.5 x DA; if more than 0.5 x DA there was a decreasing efficiency.

This was found for 2 types of torpedoes (32 and 40 knots; 20 degree lobe width) at 2 different sets of turn rates and sweep angles.

This conclusion applies for both single detection and multiple successive detections; however, the magnitude of the effect is changing as we look on different number of successive detections. The conclusion was that there is

little to be gained by offsetting the sonar lobe, and the sonar lobe was therefore not offset in subsequent investigations.

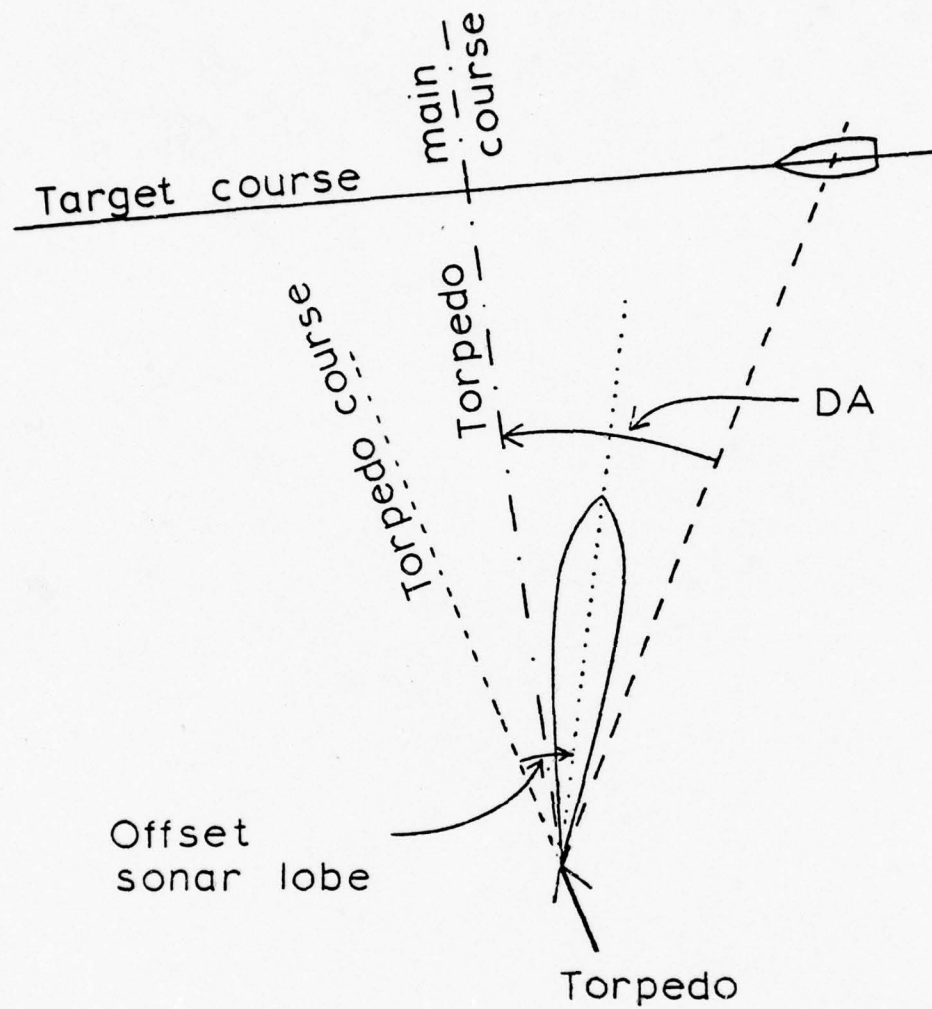

DA - Deflection angle

Figure 10 - OFFSET SONAR LOBE

Tactical Situation

Range 3000 m  
 TA Speed 18 Knots  
 Det. range 750 m

Torpedo Parameters

Sweep angle 30°  
 Lobe width 20°  
 Turn rate 6°/s

First detection

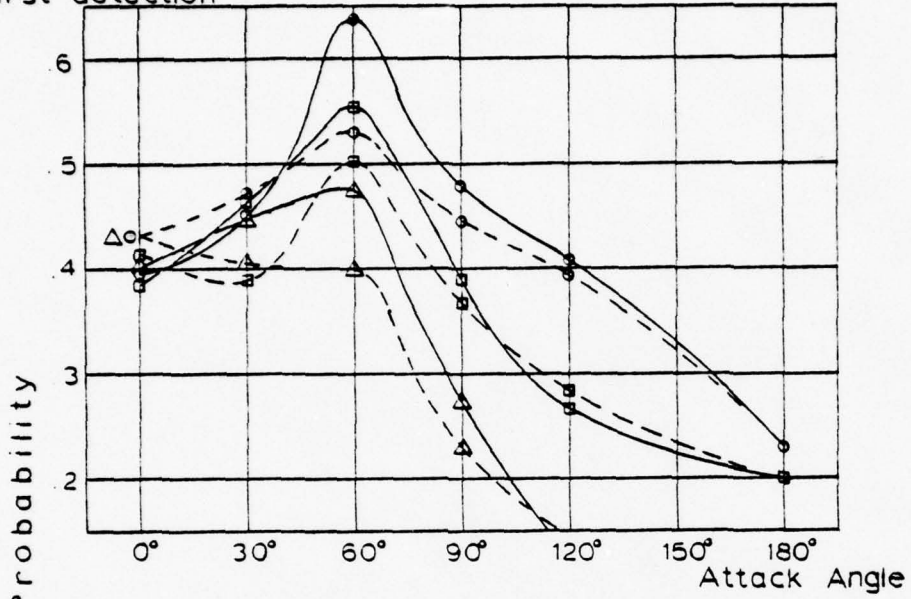

- 40 Knots
- 32 Knots
- △ 24 Knots
- Lobe not offset
- - - Lobe offset 1.0x DA

Detection

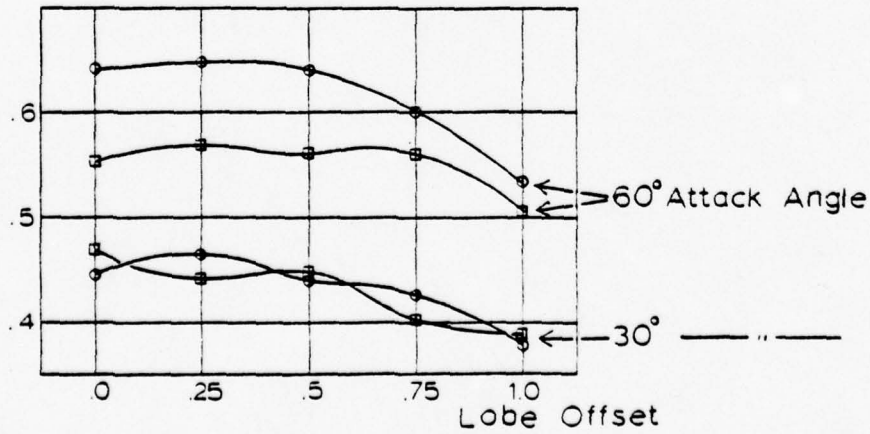

Figure 11 - EFFECT OF OFFSETTING SONAR LOBE

Tactical Situation

Range 3000 m  
 TA Speed 18 Knots  
 Det range 750 m

Torpedo Parameters

Sweep angle 30°  
 Lobe width 20°  
 Turn rate 6°/s

Two detections

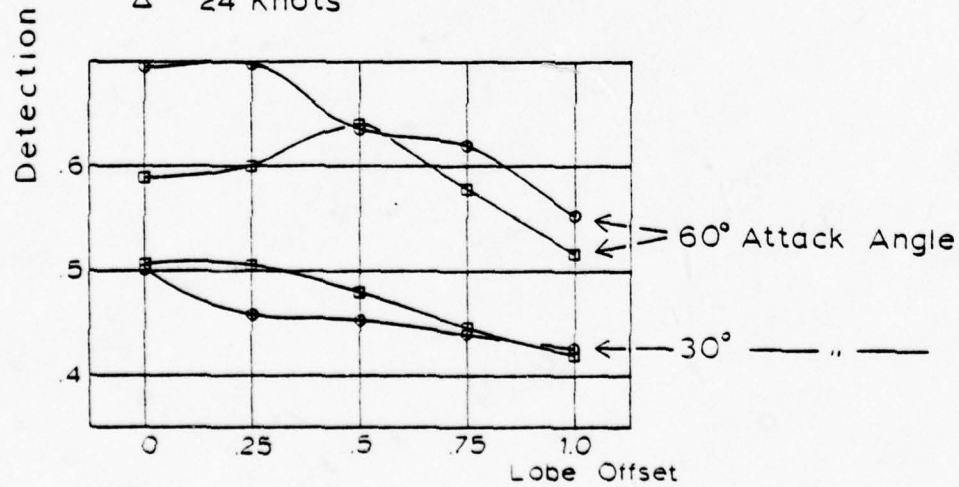
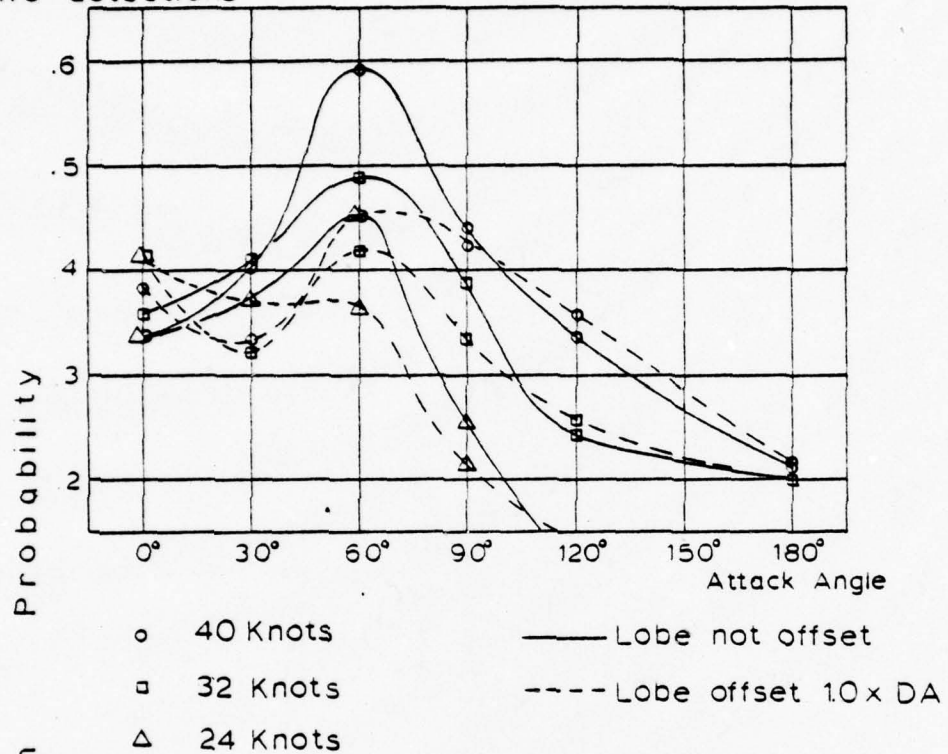

Figure 11.b. - EFFECT OF OFFSETTING SONAR LOBE

Tactical situation

Target speed 18 knots  
 Range 3000 m  
 Detection range 750 m

Torpedo parameters

Torpedo speed 24 knots  
 Sweep angle 30 degrees  
 Lobe width 20 degrees  
 Turn rate 6 deg/sec

Attack angle	1 detection		2 detections		3 detections		Offset lobe x DA
	0.0	1.0	0.0	1.0	0.0	1.0	
0	.4000	.4333	.3303	.4067	.3133	.3400	
30	.4467	.4067	.3733	.3667	.3200	.3133	
60	.4733	.4000	.4533	.3667	.4267	.3333	
90	.2733	.2267	.2533	.2133	.2400	.1867	
120	.1200	.1467	.1133	.1467	.1133	.1200	
180	.0000		.0000		.0000		

Table I - VARIATION IN OFFSETTING SONAR LOBE

Tactical situation

Target speed 18 knots  
 Range 3000 m  
 Detection range 750 m

Torpedo parameters

Torpedo speed 32 knots  
 Sweep angle 30 degrees  
 Lobe width 20 degrees  
 Turn rate 6 deg/sec

Attack angle	1 detection			2 detections			3 detections			Offset lobe x DA
	0.0	0.25	0.5	0.0	0.25	0.5	0.0	0.25	0.5	
0	.3867			.3600	.4067	.3800	.2800	.3067	.2867	0.75
30	.4667	.4400	.4467	.4067	.4000	.3467	.3400	.3067	.2867	.2733
60	.5533	.5667	.5600	.4867	.6600	.5400	.4333	.4600	.4333	.4133
90	.3933			.3867			.3067			
120	.2667			.2400			.2133			
180	.2000			.2000			.2000			

Tactical situation

Attack angle	1 detection			2 detections			3 detections			Offset lobe x DA
	1.0			1.0			1.0			
0	.4267			.4067			.2733			
30	.3867			.3200			.2733			
60	.5067			.4200			.3600			
90	.3667			.3267			.3000			
120	.2800			.2533			.2400			
180	.2000			.2000			.2000			

Table I.b. - VARIATION IN OFFSETTING SONAR LOBE

Tactical situation      Target speed 18 knots      Torpedo speed 40 knots  
 Range 3000 m      Sweep angle 30 degrees  
 Detection range 750 m      Lobe width 20 degrees  
 Turn rate 6 deg/sec

Attack angle	1 detection			2 detections			3 detections			Offset lobe x DA
	0.0	0.25	0.5	0.0	0.25	0.5	0.0	0.25	0.5	
0	.3933	.4667	.4400	.3333	.3533	.3400	.2533	.3200	.3067	.2933
30	.4467	.6400	.6400	.4000	.6000	.5200	.5400	.4733	.4200	.4000
60	.6400	.6467	.6400	.5933	.5333	.4400	.3933	.2800		
90	.4733			.4400			.2800			
120	.4067			.3400			.2000			
180	.2267			.2133						

Tactical situation

Attack angle	1 detection			2 detections			3 detections			Offset lobe x DA
	1.0			1.0			1.0			
0	.4333			.3800			.2733			
30	.3733			.3267			.2733			
60	.5333			.4533			.4067			
90	.4467			.4200			.3600			
120	.3933			.3600			.3333			
180	.2333			.2200			.2000			

Table I.c. - VARIATION IN OFFSETTING SONAR LOBE

### C. EFFECT OF TURN RATE

The effect of turn rate was investigated in the range 3 to 21 degrees per second in steps of 3. For both types of torpedoes the model showed an increase in MOE as turn rate was increased. The MOE leveled off as turn rate was approaching 15 - 20 degrees per second.

The reason may be due to the 1 second transmission interval and the 20 degree lobe width, which indicates that the torpedo should be turned at a turn rate equal to lobe width divided by transmission interval for maximum MOE. However, as the number of successive detections required is increased, we get maximum MOE at lower turn rates.

Fig. 12 shows the change in MOE with turn rate for 30 and 60 degrees attack angles.

From Fig. 15 where different combinations of turn rates and sweep angles are plotted versus MOE, we see that the effect is negligible from about 60-80 degrees to 180 degrees attack angle.

A 6 degrees per second turn rate is compared with what may be termed an 'optimal' turn rate in Fig. 13. The 'optimal' turn rates were established by the general trend from Fig. 12 and Table II.a and II.b.

The following turn rates were identified as 'optimal';

- 15 degrees per second for the 32 knots torpedo
- 18 degrees per second for the 40 knots torpedo.

Tactical Situation: Range 3000 m  
 TA Speed 18 Knots  
 Det. range 750 m

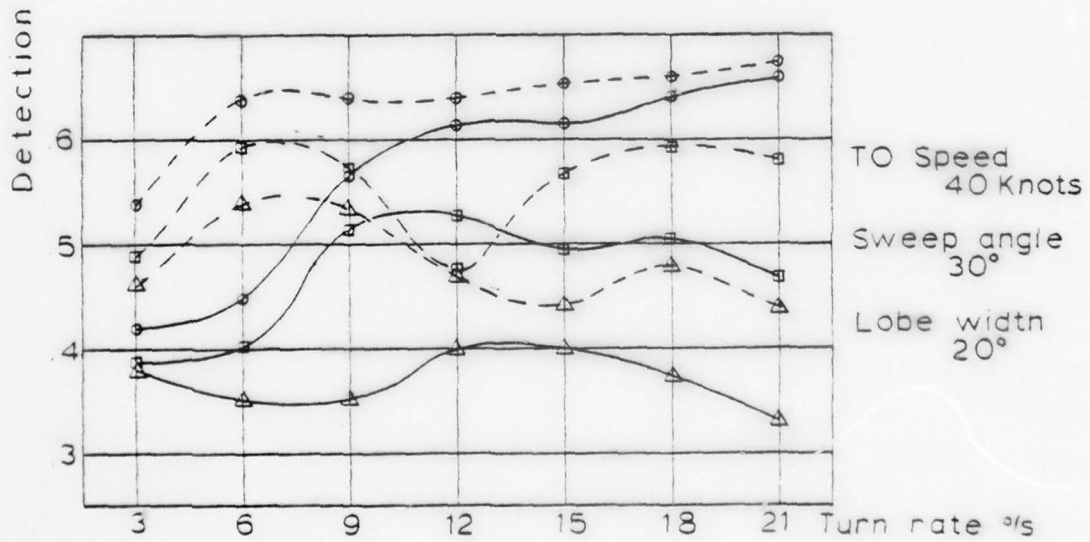
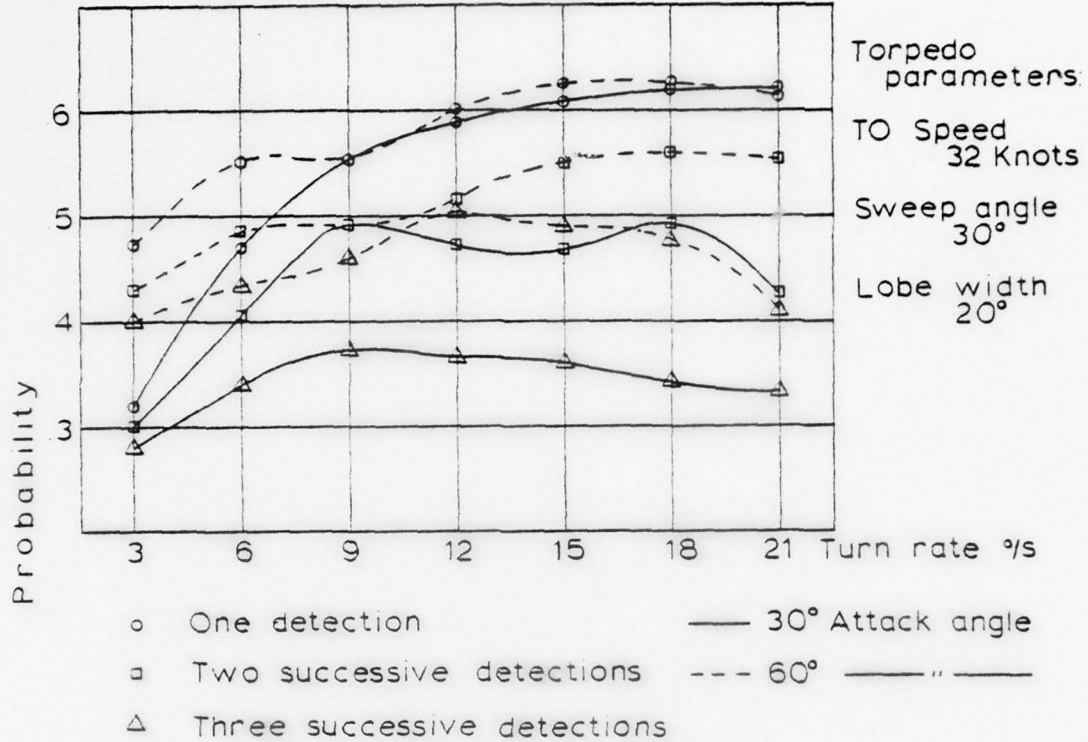

Figure 12 - EFFECT OF TURN RATE

Tactical Situation:      Range            3000 m  
                                  TA Speed        18 Knots  
                                  Det. range      750 m

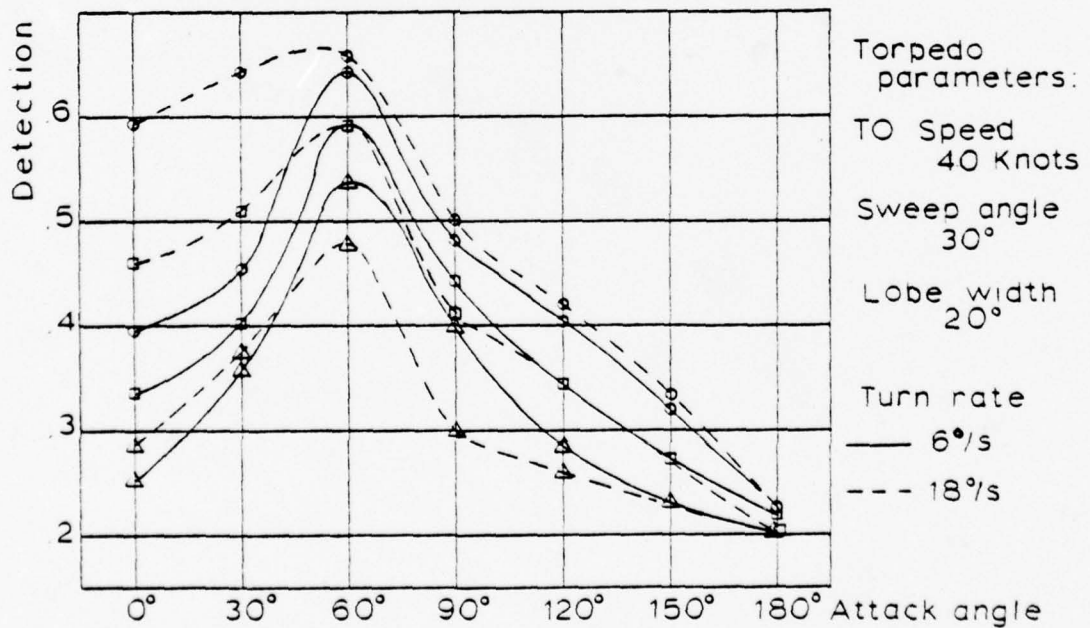
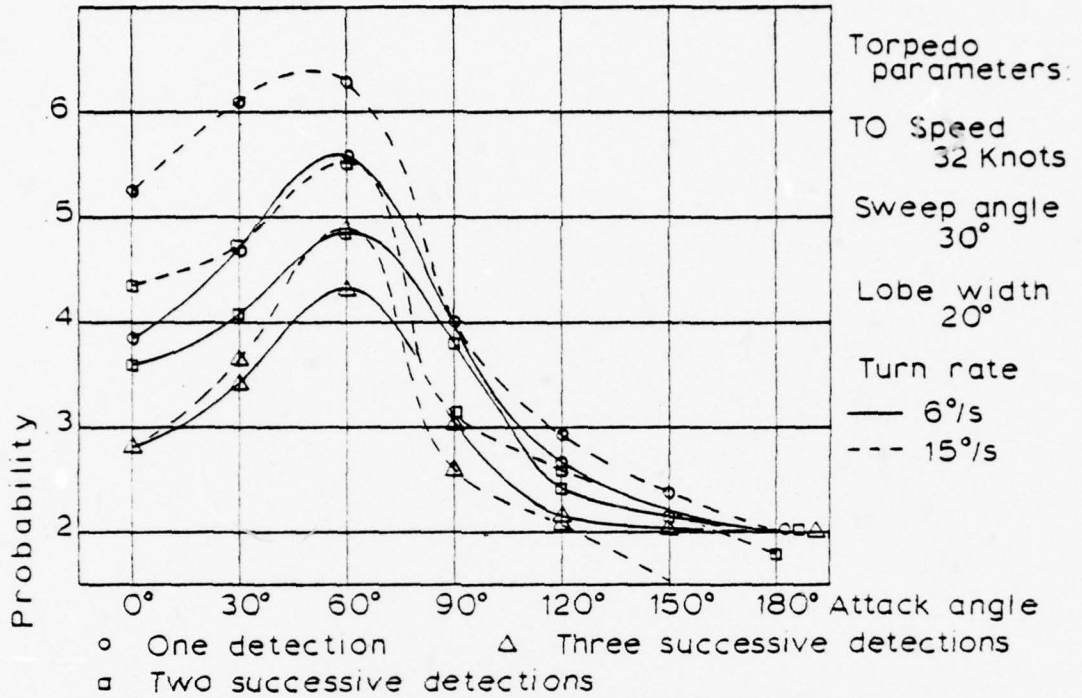

Figure 13 - COMPARISON OF TORPEDOES WITH DIFFERENT TURN RATES

We see here in Fig. 13 a considerable increase in MOE with increase in turn rate for attack angles less than 60 - 80 degrees for single detection; an consistent improvement for 2 successive detections in the same area; but no change or a slight detoriation for 3 successive detections.

It is quite obvious that a torpedo which requires only a single detection as requirement for attack has a considerably better MOE, and a considerably higher potential for improvement by changes in turn rate, than a torpedo which requires more successive detections for classifying a contact as a target.

Tactical situation  
 Target speed 18 knots  
 Range 3000 m  
 Detection range 750 m

Torpedo parameters  
 Torpedo speed 40 knots  
 Sweep angle 30 degrees  
 Lobe width 20 degrees

Attack angle	1 detection			2 detections			3 detections			Turn rate deg/sec
	3	6	9	3	6	9	3	6	9	
0	.3933	.5733	.3333	.4600	.2533	.2667	.3800	.2533	.2667	.4000
30	.4200	.6133	.4000	.5267	.4000	.3533	.4600	.3533	.4000	.4667
60	.5333	.6400	.5933	.4867	.4400	.5733	.4600	.4400	.5333	.3600
90	.6400	.4733	.4400	.3400	.2800	.2933	.2800	.2800	.2800	.2000
120	.4067									
180	.2267									

Tactical situation

Torpedo parameters

Attack angle	1 detection			2 detections			3 detections			Turn rate deg/sec
	12	15	18	12	15	18	12	15	18	
0	.5733	.5933	.4600	.4600	.4600	.2867	.2667	.2867	.2867	.3300
30	.6133	.6400	.6600	.5267	.4933	.5067	.4667	.4000	.3733	.4400
60	.6400	.6600	.6733	.4667	.5667	.5933	.4667	.4400	.4800	.4400
90	.4733	.4933	.4400	.4400	.4067	.4067	.3600	.2933	.2933	.2600
120	.4200	.4200	.2000	.3467	.2000	.2000	.2600	.2600	.2600	.2000
180	.2267									

Table II.b. - VARIATION IN TORPEDO TURN RATE

#### D. EFFECT OF SWEEP ANGLE

From preliminary simulation runs, it was found that from 90 degrees (inclusive) to 180 degrees attack angle the effect of the sweep angle was negligible. The analysis was therefore done from 20 to 50 degrees sweep angle only for 30 and 60 degrees attack angle for both the 32 and the 40 knots torpedo.

The result is shown in Fig. 14.

For the 32 knot torpedo we get an increase from 30 to 40 degrees for both attack angles. From 40 to 50 degrees, MOE either levels off or decrease slowly. As a conclusion, we established 40 degrees sweep angle as the 'optimal' value. For the 40 knot torpedo, the MOE was fairly steady over the whole range for 30 degrees attack angle. For 60 degrees attack angle, there was a peak at 30 degrees sweep angle, which indicated that 30 degrees was the optimal value.

The reason for the different sweep angles for the two torpedo types (Note; both have 6 degrees per second turn rate) may be due to the time it takes to reach the target. The shorter time, the less area on each side of the main course is needed to be covered in order to detect a target; i.e. a 40 knot torpedo needs only a 30 degree sweep angle, a 32 knot torpedo needs 40 degree sweep angle.

Tactical Situation:	Range	3000 m
	TA Speed	18 Knots
	Det. range	750 m
Torpedo Parameters:	Lobe width	20°
	Turn rate	6°/s

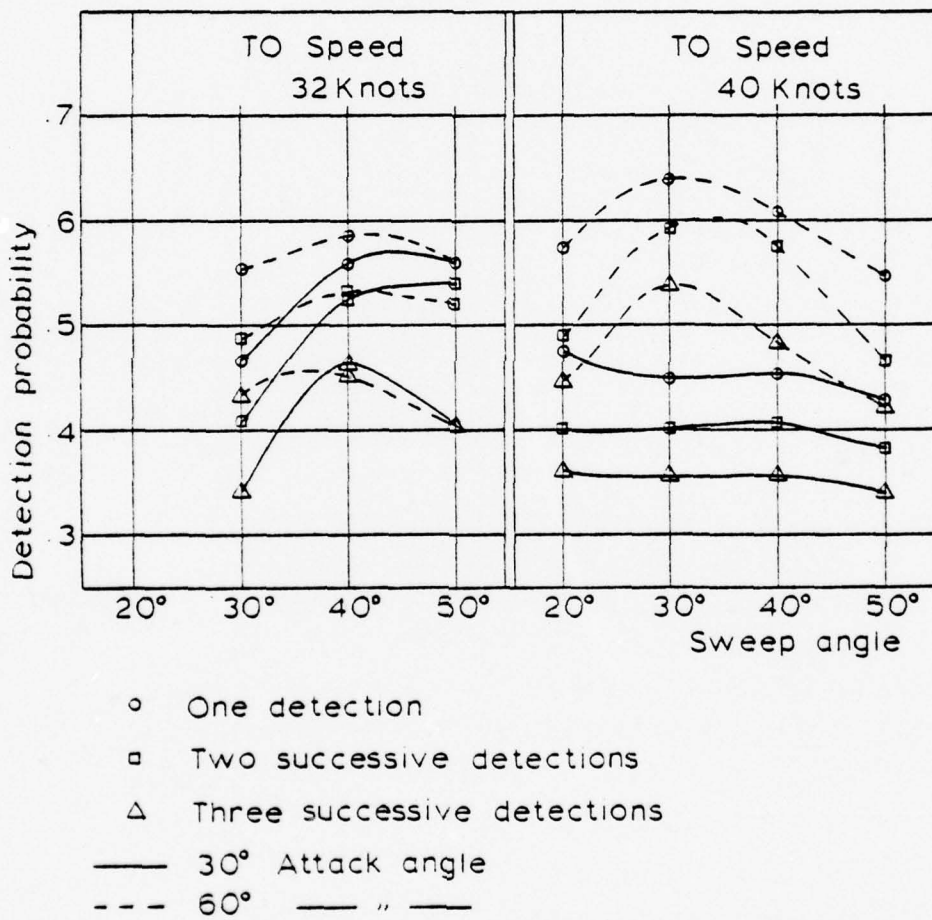

Figure 14 - EFFECT OF SWEEP ANGLE

The reason why we get a peak and then a reduction in MOE as we increase sweep angle is supposedly due to a sharp decrease in speed along the main course as sweep angle is approaching 60 degrees.

As example, for a 40 knots torpedo the model gave 35 knots along main course for 50 degrees sweep angle as compared with 38.6 knots for 20 degrees sweep angle. For a slower torpedo, the effect on MOE may be considerable due to less speed advantage relative to the target.

Tactical situation

Target speed 18 knots  
 Range 3000 m  
 Detection range 750 m

Torpedo parameters

Torpedo speed 32 knots  
 Lobe width 20 degrees  
 Turn rate 6 deg/sec

Attack angle	1 detection			2 detections			3 detections			Sweep angle degree	
	20	30	40	20	30	40	20	30	40		50
0		.3867	.3933		.3600	.3267			.2800	.2600	
30		.4667	.5600		.4067	.5267			.3400	.4600	.4067
60		.5533	.5867		.4867	.5333			.4333	.4533	.4067
90		.3933	.3733		.3867	.3733			.3067	.3400	
120		.2667	.2800		.2400	.2667			.2133	.2333	
180		.2000	.2000		.2000	.2000			.2000	.1867	

Tactical situation

Target speed 18 knots  
 Range 3000 m  
 Detection range 750 m

Torpedo parameters

Torpedo speed 40 knots  
 Lobe width 20 degrees  
 Turn rate 6 deg/sec

Attack angle	1 detection			2 detections			3 detections			Sweep angle degree	
	20	30	40	20	30	40	20	30	40		50
0		.3933			.3333				.2533		
30	.4733	.4467	.4533		.4000	.4067		.3600	.3533	.3533	.3400
60	.5733	.6400	.6067		.5933	.5733		.4467	.5400	.4800	.4200
90		.4733			.4400			.3933			
120		.4067			.3400			.2800			
180		.2267			.2133			.2000			

Table III - VARIATION IN SWEEP ANGLE

#### E. EFFECT OF BOTH SWEEP ANGLE AND TURN RATE

In the previous discussion we changed either sweep angle or turn rate for both types of torpedo while we kept the other variables constant.

In plotting MOE for initial torpedo (32 knots) value, optimal value for sweep angle, optimal value for turn rate and the 'optimal' torpedo (having both the 'optimal' turn rate and sweep angle), we get Fig. 15.

Observe how the MOE changes as we apply the individual 'optimal' values, and the MOE obtained by applying both the 'optimal' values.

At this stage, no trials were made in order to further increase MOE by changing sweep angle or turn rate from these values.

One essential feature is that virtually none of the variables so far have had any effect on MOE for larger attack angles than 60-90 degrees.

The relative difference in MOE between the 32 and the 40 knots torpedo types is shown in Fig. 16. Both torpedoes are optimal in the sense that the best values for turn rate and sweep angle have been chosen for that specific speed.

Tactical Situation:  
 Range 3000 m  
 TA Speed 18 Knots  
 Det. range 750 m

Torpedo parameters  
 TO Speed 32 Knots  
 Lobe width 20°

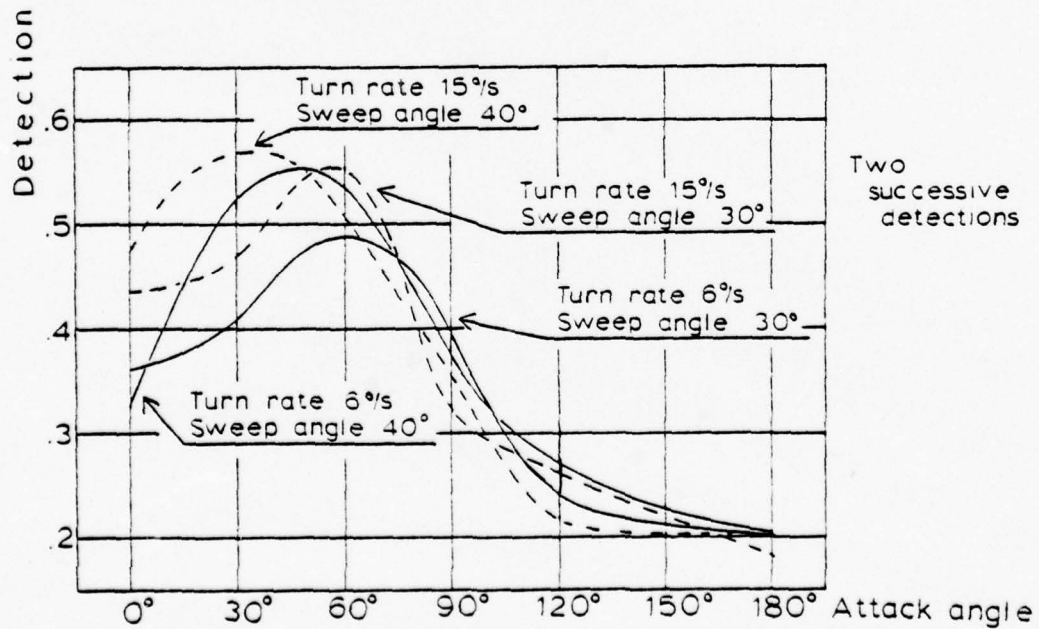
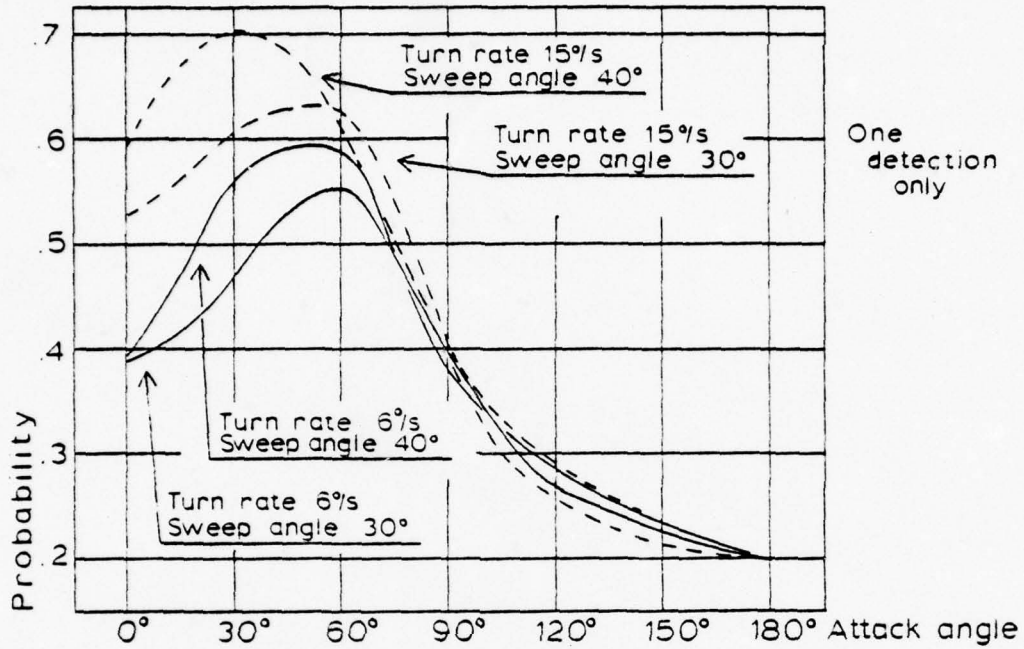
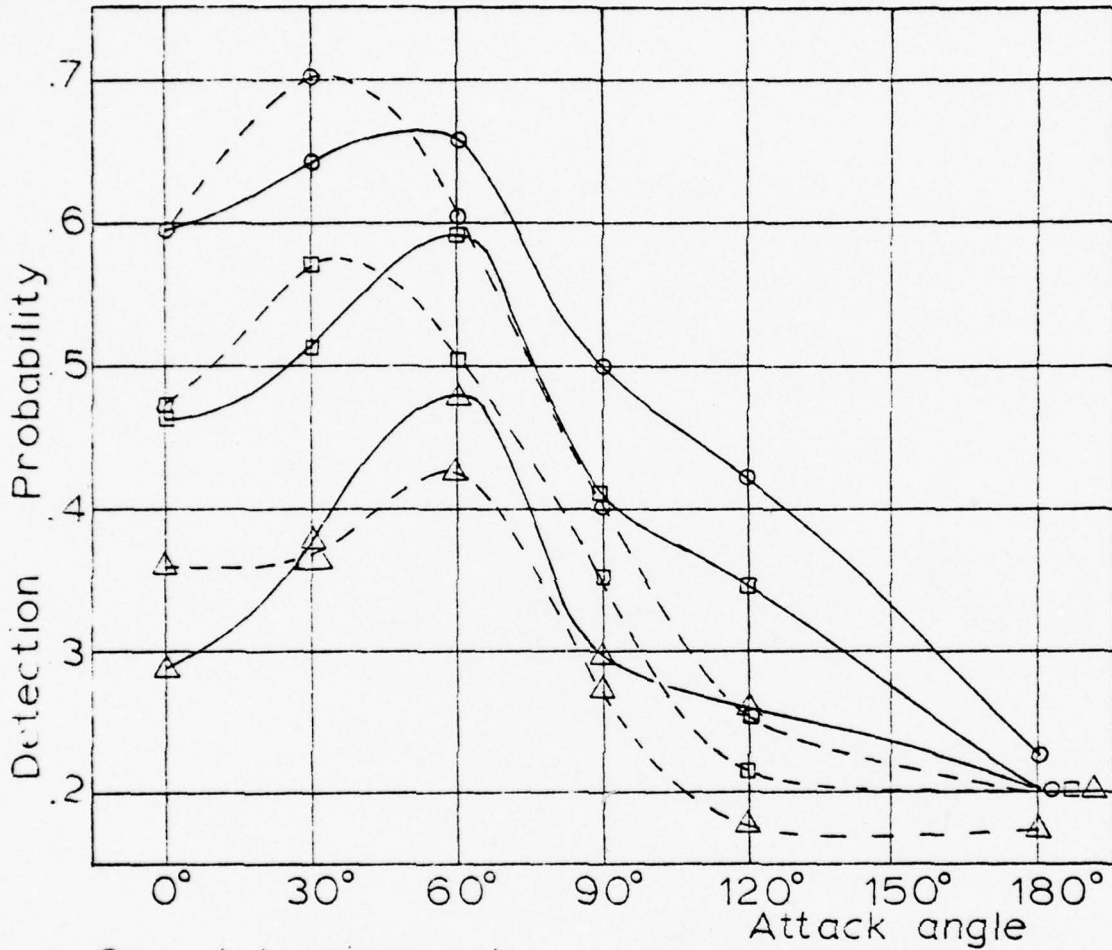

Figure 15 - COMPARISON OF DIFFERENT MODIFICATION OF A TORPEDO

Tactical Situation: Range 3000 m  
 TA Speed 18 Knots  
 Det. range 750 m



○ One detection only  
 □ Two successive detections  
 △ Three " " " "

— { TO Speed 40 Knots      32 Knots } ---  
 Turn rate 18%/s      15%/s  
 Sweep angle 30°      40°

Figure 16 - COMPARISON OF TWO DIFFERENT TORPEDOES

It is obvious that the main differences are for large attack angles; more than 60-80 degrees. Especially if the acquisition requirement is one detection only, however, a 32 knots torpedo is slightly better up to 60 degrees attack angle. This improved MOE for the slower torpedo may be explained by a better balance between the time to the target and the total relative speed. A too high relative speed may prohibit the torpedo from getting the target within its sonar lobe before the target is passed.

Generally, however, the higher speed torpedo is superior, especially for larger attack angles (120 degrees and more); this can be explained by the shorter time to the target.

#### F. EFFECT OF LOBE WIDTH

The effect of changing lobe width while maintaining detection range is shown in Fig. 17. It should be noted that we initially started the simulation with an 'optimal' torpedo with 20 degrees lobe width. When we ran the simulation series for 10 degrees and 30 degrees lobe width, we did not change the other torpedo parameters in order to make the torpedo 'optimal' for the new lobe width. If we had carried through this optimization process, we might have expected an increase in the result for 10 and 30 degrees lobe width. The torpedo parameter in question would most likely be turn rate, ref discussion previously on page 61.

The interesting points from Fig. 17 are;

- a 10 degrees lobe width torpedo with a one-detection-only acquisition requirement is as good

as a 20 degrees lobe width torpedo with a two-successive-detection requirement. This should indicate what we have to pay in additional power transmitted when acquisition requirement is high. Or, where to invest research resources; in transducer or in echo filtering.

- the equally shaped curves for increasing lobe width. However, we also observe an increasing difference in MOE between the curves as attack angle is decreasing.
- the importance of the correct balance between turn rate and lobe width for successive detections. We observe for a small aspect target how MOE decreases drastically when we reduce lobe width from 20 degrees to 10 degrees and maintain turn rate and require two successive detections.

Tactical Situation  
 TA Speed 18 knots  
 Det range 750 m  
 Range 3000 m

Torpedo Parameter  
 TO Speed 40 Knots  
 Sweep angle 30°  
 Turn rate 18 %/s

△ 10° Lobe width  
 □ 20° " "  
 ○ 30° " "

———— One detection only  
 - - - - Two successive detections

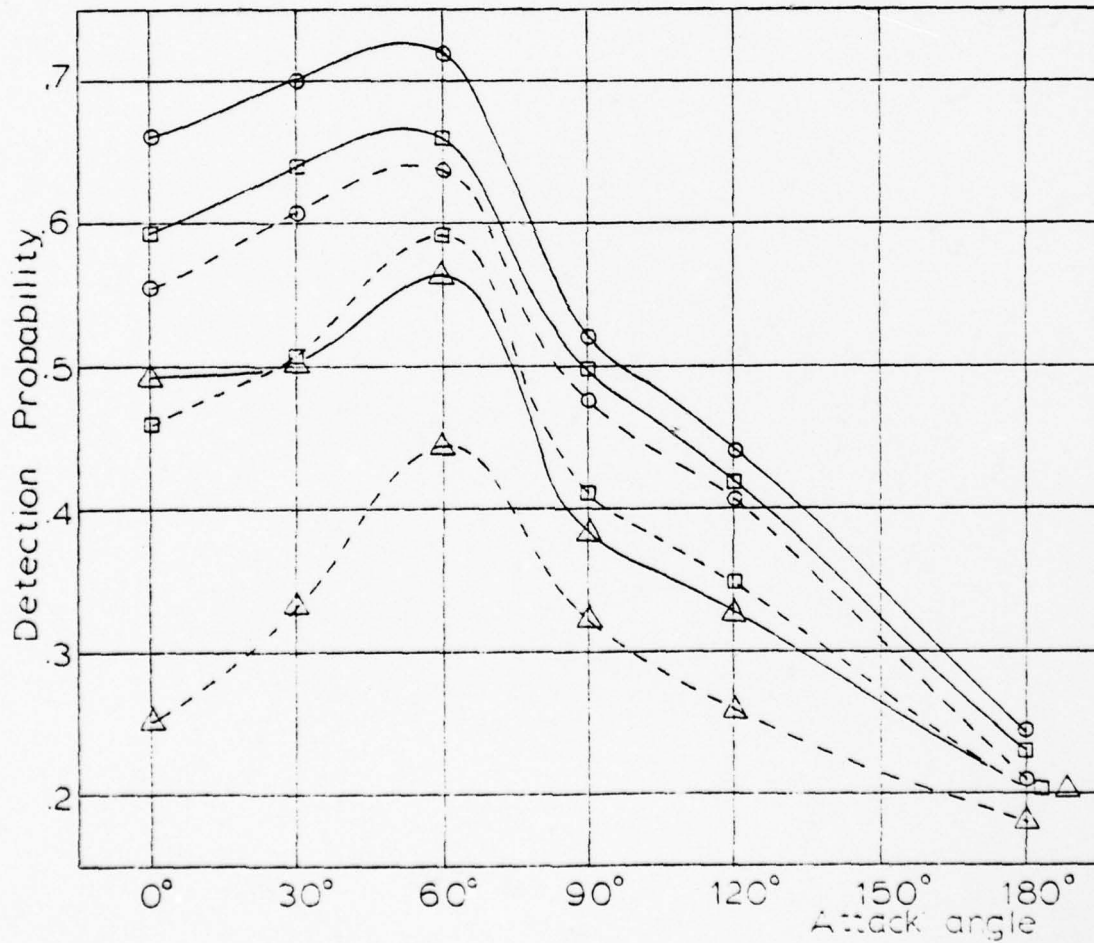

Figure 17 - EFFECT OF LOBE WIDTH

Tactical situation

Target speed 18 knots  
 Det. range 750 m  
 Range 3000 m

Torpedo parameters

Torpedo speed 40 knots  
 Sweep angle 30 degrees  
 Turn rate 18 deg/s

Attack angle	1 detection			2 detections			3 detections			Lobe width degrees
	10	20	30	10	20	30	10	20	30	
0	.4933	.5933	.6667	.2167	.4600	.5533	.1133	.2867	.4200	
30	.5000	.6400	.7000	.3267	.5067	.6067	.2333	.3733	.4800	
60	.5667	.6600	.7200	.4167	.5933	.6400	.3067	.4800	.5167	
90	.3800	.4933	.5133	.3200	.4067	.4733	.2267	.2933	.4000	
120	.3267	.4200	.4400	.2600	.3467	.4067	.1800	.2600	.3267	
180	.2000	.2267	.2400	.1800	.2000	.2067	.0867	.2000	.2000	

Table IV - VARIATION IN LOBE WIDTH

## G. EFFECT OF DETECTION RANGE

The detection range is a function of the design of the active sonar in the torpedo as well as sonar condition at the time of the torpedo firing. The detection range as a function of the design of the active sonar is termed technical detection range. The detection range as a function of both the design and the sonar conditions is termed tactical detection range, or just detection range. In analyzing the detection probability as a function of detection range, we assumed optimal sonar conditions by equal technical detection range with detection range.

Detection range was varied in discrete steps: 375 - 750 - 1125 - 1500 meters.

Figs. 18.a. and b. indicate that detection probability is a linear function of the detection range up to a detection probability of 0.8 - 0.9 for one detection. From the model, it may be justifiable to approximate the detection probability as a linear function from 375 m to 1125 m detection range.

From the model and the given assumptions, there is little usefulness in a homing torpedo with less than 300 m detection range.

The same situation is shown in Figs. 19.a. and b. in another cut of the response surface. We see here how consistently the MOE has decreased over the whole range of attack angles when going from 1500 m to 375 m detection range.

Tactical Situation:  
 TA Speed 18 Knots  
 Range 3000 m

Torpedo Parameters:  
 TO Speed 32 Knots  
 Lobe width 20°  
 Sweep angle 40°  
 Turn rate 15°/s

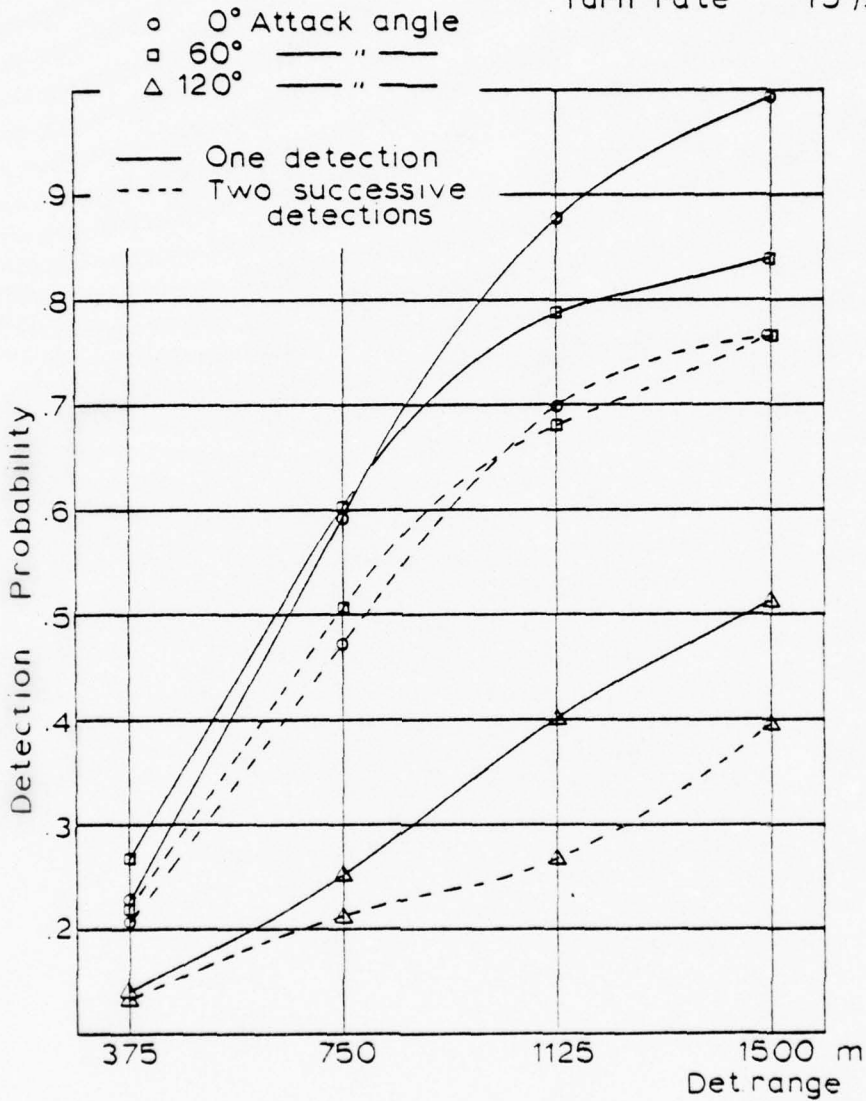

Figure 18 - EFFECT OF DETECTION RANGE

Tactical Situation:  
 TA Speed 18 Knots  
 Range 3000 m

Torpedo Parameters:  
 TO Speed 40 Knots  
 Lobe width 20°  
 Sweep angle 30°  
 Turn rate 18°/s

○ 0° Attack angle  
 □ 60 " "  
 △ 120 " "

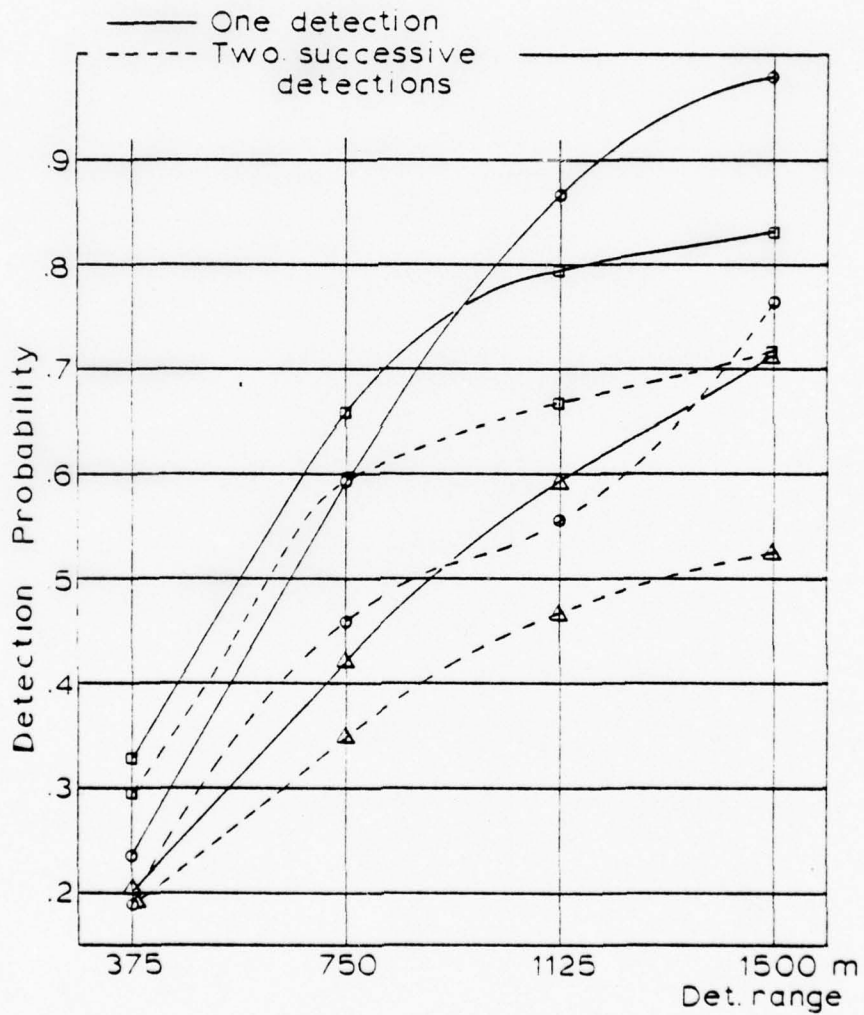

Figure 18.b. - EFFECT OF DETECTION RANGE

Otherwise the picture in Figs. 19.a. and b. is as in previous similar figures; a marked decrease in MOE with attack angles more than 60 - 90 degrees, and with the faster torpedo superior over most of the range. It should, however, be noted that for longer detection ranges we get maximum MOE at 0 degree attack angle for both torpedo types. This effect is reduced when we require two successive detections for acquisition.

We also experienced a considerable decrease in MOE for longer detection ranges when requiring two successive detections instead of one. It seems obvious that this reduction is due to a larger lateral movement at the extreme range. As noted previously, we increase the transmission interval (increase interval in order to allow time for echo to return) when the detection range is increased. Keeping the same turn rate, the sonar lobe will turn a larger angle between each transmission, which can have a deteriorating effect on MOE for more than a one-detection-only acquisition requirement.

Torpedo Parameters		Tactical Situation	
TO Speed	32 40 Knots	TA Speed	18 Knots
Lobe width	20 20°	Range	3000 m
Sweep angle	40 30°		
Turn rate	15 18 %/s		

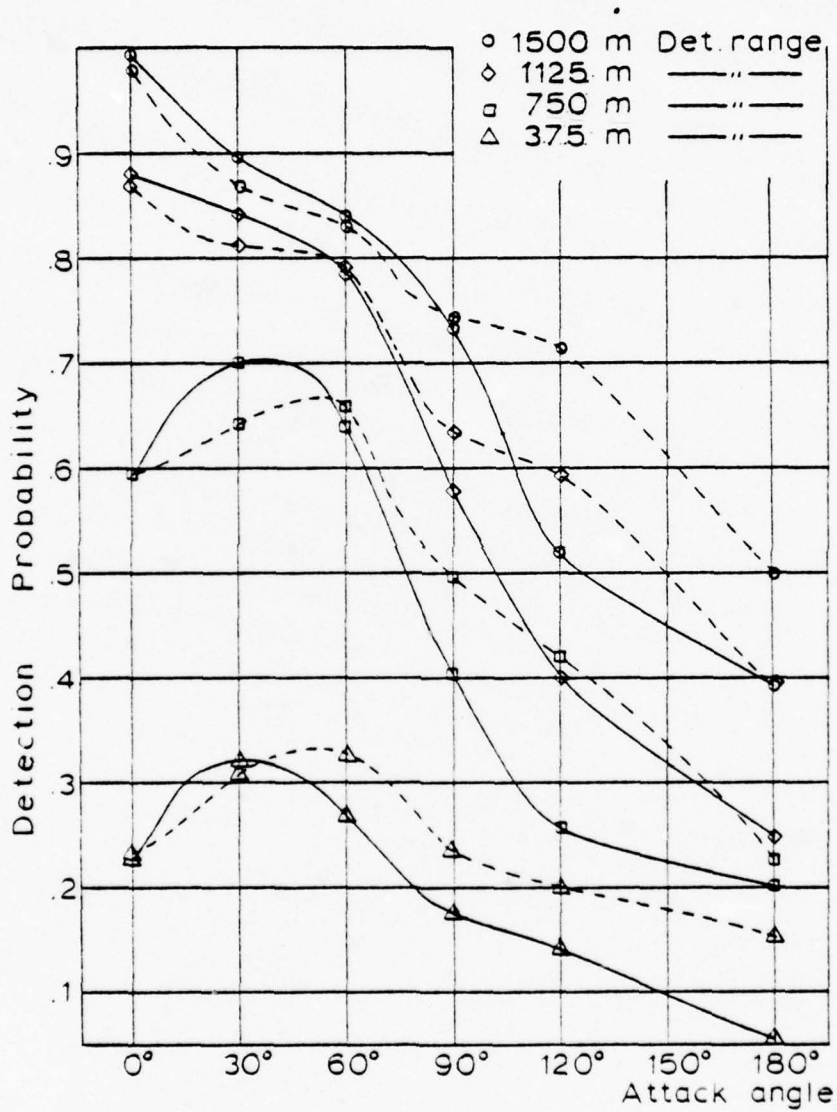

Figure 19 - COMPARISON OF TWO TORPEDOES WITH CHANGE IN DETECTION RANGE

Torpedo Parameters:

TO Speed 32 40 Knots  
 Lobe width 20 20°  
 Sweep angle 40 30°  
 Turn rate 15 18 %/s

Tactical Situation:

TA Speed 18 Knots  
 Range 3000 m

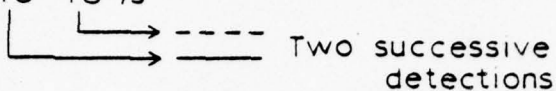

- 1500 m Det. range
- ◇ 1125 m " "
- 750 m " "
- △ 375 m " "

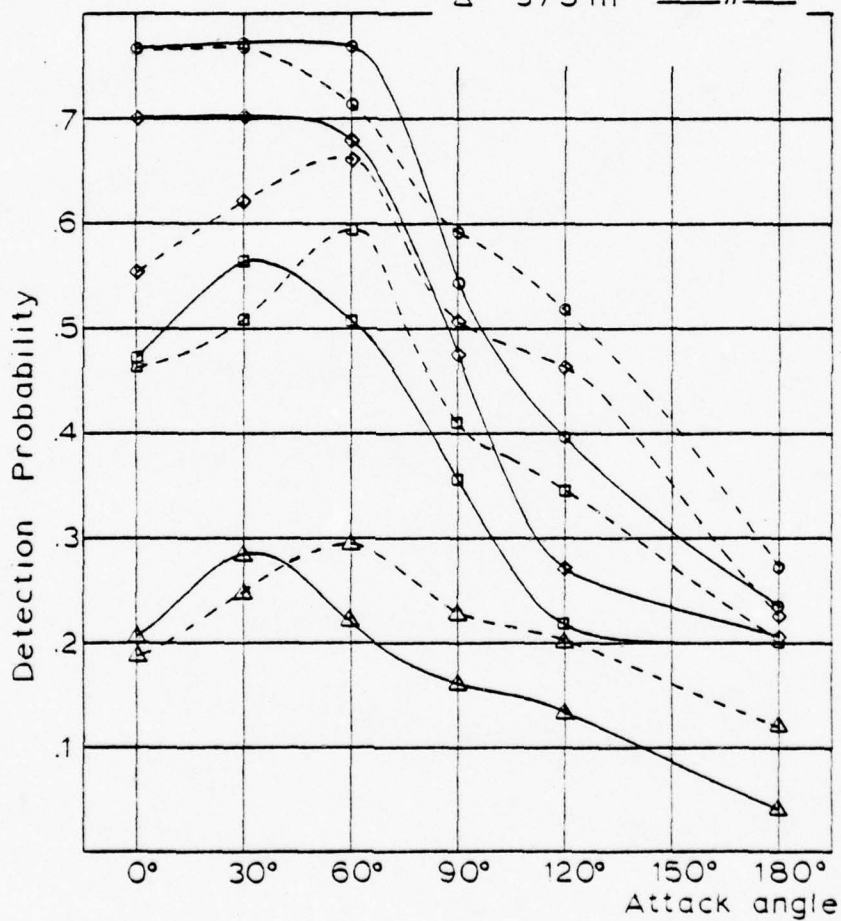

Figure 19.b. - COMPARISON OF TWO TORPEDOES WITH CHANGE IN DETECTION RANGE

Tactical situation

Torpedo parameters

Target speed 18 knots  
 Range 3000 m  
 Torpedo speed 32 knots  
 Sweep angle 40 degrees  
 Lobe width 20 degrees

Attack angle	1 detection			2 detections			3 detections			Detection range m
	375	750	1125	375	750	1125	375	750	1125	
0	.2267	.5933	.8800	.2067	.4733	.7000	.1667	.3600	.4800	1500
30	.3200	.7000	.8333	.2867	.5667	.7000	.2600	.3667	.5267	.5933
60	.2667	.6067	.7867	.2200	.5067	.6800	.1933	.4267	.5600	.6067
90	.1733	.4000	.5800	.1600	.3533	.4733	.1400	.2733	.3667	.3667
120	.1400	.2533	.4000	.1333	.2133	.2667	.1200	.1733	.1867	.2333
180	.0533	.2000	.2467	.0400	.2000	.2067	.0267	.1733	.1933	.2000

Tactical situation

Torpedo parameters

Target speed 18 knots  
 Range 3000 m  
 Torpedo speed 40 knots  
 Sweep angle 30 degrees  
 Lobe width 20 degrees

Attack angle	1 detection			2 detections			3 detections			Detection range m
	375	750	1125	375	750	1125	375	750	1125	
0	.2333	.5933	.8667	.1867	.4600	.5533	.1267	.2867	.3533	.4000
30	.3067	.6400	.8133	.2467	.5067	.6200	.1933	.3733	.4133	.4400
60	.3267	.6600	.7933	.2933	.5933	.6667	.2200	.4800	.5000	.6267
90	.2333	.4933	.6333	.2267	.4067	.5067	.1733	.2933	.3133	.3867
120	.2000	.4200	.5933	.2000	.3467	.4667	.1733	.2600	.3133	.3333
180	.1533	.2267	.3867	.1200	.2000	.2267	.0867	.2000	.2000	.2200

Table V - VARIATION IN DETECTION RANGE

## H. COMBINED EFFECT OF LOBE WIDTH AND DETECTION RANGE

The following approximate relationships exist between lobe width, detection range and sonar power:

$$P = \frac{P_0 \cdot G_t \cdot \sigma \cdot G_r \cdot \lambda^2}{(4\pi)^3 \cdot R} \quad \text{Watts} \quad (4.9)$$

where

$$G_t = G_r = (4 \cdot \pi / w) \quad (6.1)$$

$$w = L^2$$

$$L = 2 \times \text{lobe width.}$$

Ref [1;49].

w is defined as solid angle. The given equation is valid for small lobe width only. For larger lobe width the exact relationship is;

$$w = 2 \cdot \pi \cdot (1 - \cos l) \quad (6.2)$$

$$l = \text{lobe width.}$$

The approximate relationship is close enough up to 60 degrees lobe width.

By substituting the approximate relationship into Eq. 4.9, we get a reduction of  $L^4$  in receiving echo due to change in lobe width,  
or

$$(L \cdot R)^4 = \text{constant}, \quad (6.3)$$

which combine range and lobe width, and implies that detection range is inverse proportional to lobe width for constant power transmitted.

It is therefore possible to plot this function for constant power transmitted, and use this as a prediction of how MOE may change with change in these two torpedo parameters (lobe width and detection range).

This is done in Fig. 20; and indicated by the dashed line going through 20 degrees lobe width and 750 m detection range.

We then ran some simulation series in order to generate data points from the model. The data points gave the MOE, and by fitting curves we were able to get some indication of the relationship between the lobe width and the detection range as given by the model.

The application could be as follows;

For a given torpedo with lobe width 20 degrees and a detection range of 750 m, we ask the question, can MOE be increased without increasing power transmitted?

The dashed curve through the point (20 degrees, 750 m) is a constant power curve, and by following the curve we observe how MOE is changing.

From the figure, it is obvious that a narrower lobe and a longer detection range gives a better result. But we also observe the asymptotical feature of the curves. We reach a point where the constant power curve and the constant MOE curve are parallel.

However, it should be born in mind that the theoretical relationship between lobe width and detection range is an approximation which does not account for absorption-effect or surface-effect. This implies that the constant power

curve in real life will be lowered. Only a more detailed analysis can say how much.

Tactical Situation:  
 TA Speed 18 Knots  
 Range 3000 m

Torpedo Parameter:  
 TO Speed 40 Knots  
 Sweep angle 30°  
 Turn rate 18 %/s

One detection only

———— Constant detection probability  
 - - - - - Constant power transmitted

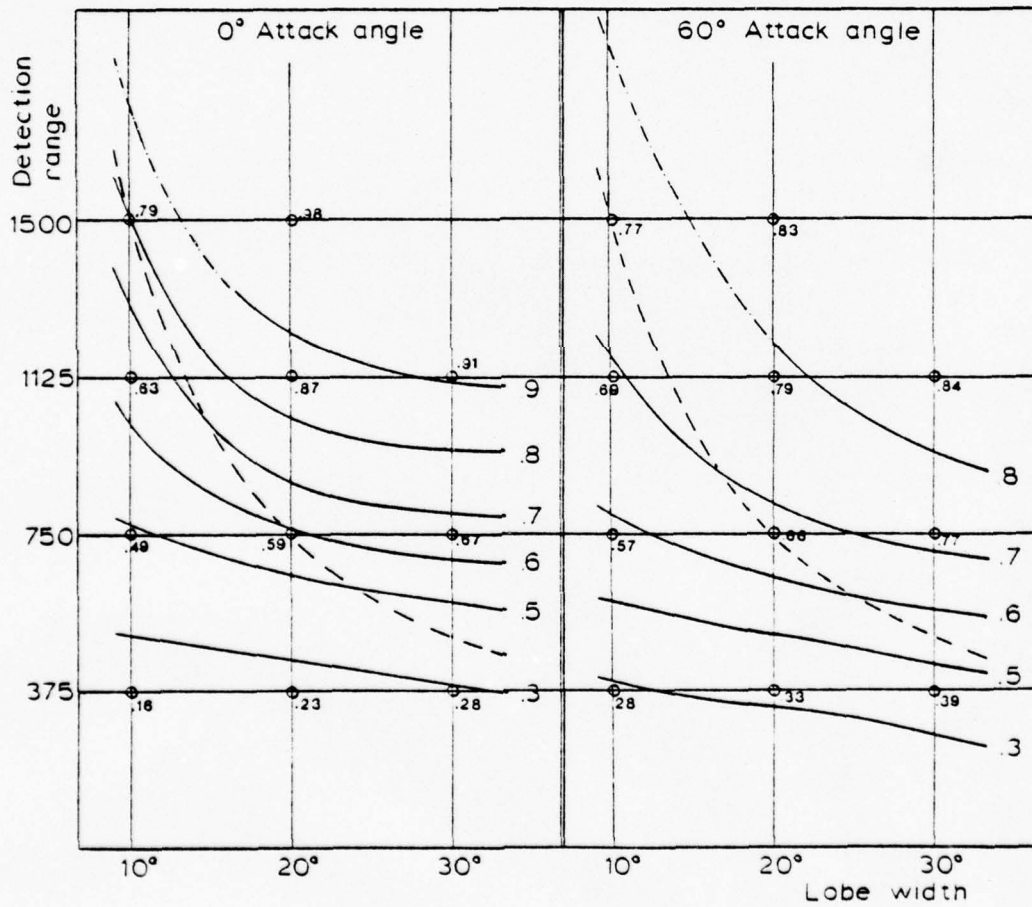

Figure 20 - VARIATION IN EFFECTIVENESS AS A FUNCTION OF LOBE WIDTH AND DETECTION RANGE

Tactical situation

Target speed 18 knots  
Range 3000 m

Torpedo parameters

Torpedo speed 40 knots  
Sweep angle 30 degrees  
Turn rate 18 deg/s

Attack angle	1 detection		2 detections		3 detections		Detection range m
	375	750	1125	1500	375	750	
0°	.1600	.4933	.6267	.7867	.1200	.1133	1500
60°	.2800	.5667	.6933	.7733	.0867	.3067	.1600 .3667
0°	.2333	.5933	.8667	.9800	.7667	.2867	4000
60°	.3267	.6400	.7933	.8333	.7133	.4800	.6267 .5000

Tactical situation

Target speed 18 knots  
Range 3000 m

Torpedo parameters

Torpedo speed 40 knots  
Sweep angle 30 degrees  
Turn rate 18 deg/s

Attack angle	1 detection		2 detections		3 detections		Detection range m
	375	750	1125	1500	375	750	
0°	.2000	.6667	.9133		.1867	.4200	1500
60°	.3867	.7200	.8000		.3333	.5467	.4867 .6067

Table VI - VARIATION IN BOTH LOBE WIDTH AND DETECTION RANGE

## I. EFFECT OF FIRING RANGE

The most important factor in achieving high detection probability is the difference between estimated target position and actual target position at the time when the torpedo is in position to detect. The effect on the detection probability is mainly due to the time the torpedo takes to reach within detection range of target and the speed/course errors in target data.

As we increased the firing range, we experienced as anticipated a degradation in MOE. This degradation was experienced for both the 32 and the 40 knots torpedo.

The variation in firing ranges were at the following values: 1500 - 3000 - 5000 - 7000 meters.

Fig. 21.a. and b. shows consistently the importance of short firing ranges. This applies to both one detection and two successive detections.

Fig. 22.a. and b. shows an additional advantage with short firing ranges; a considerable improvement at firing with small aspect (attack angle), less than 30 degrees. Again this applies for both types of torpedoes.

Also, we get an indication that at short ranges, about 1500 meters, there is no significant difference in MOE of the two types of torpedoes up to an attack angle of 90 degrees.

Tactical Situation:  
 TA Speed 18 Knots  
 Det range 750 m

Torpedo Parameters:  
 TO Speed 32 Knots  
 Lobe width 20°  
 Sweep angle 40°  
 Turn rate 15°/s

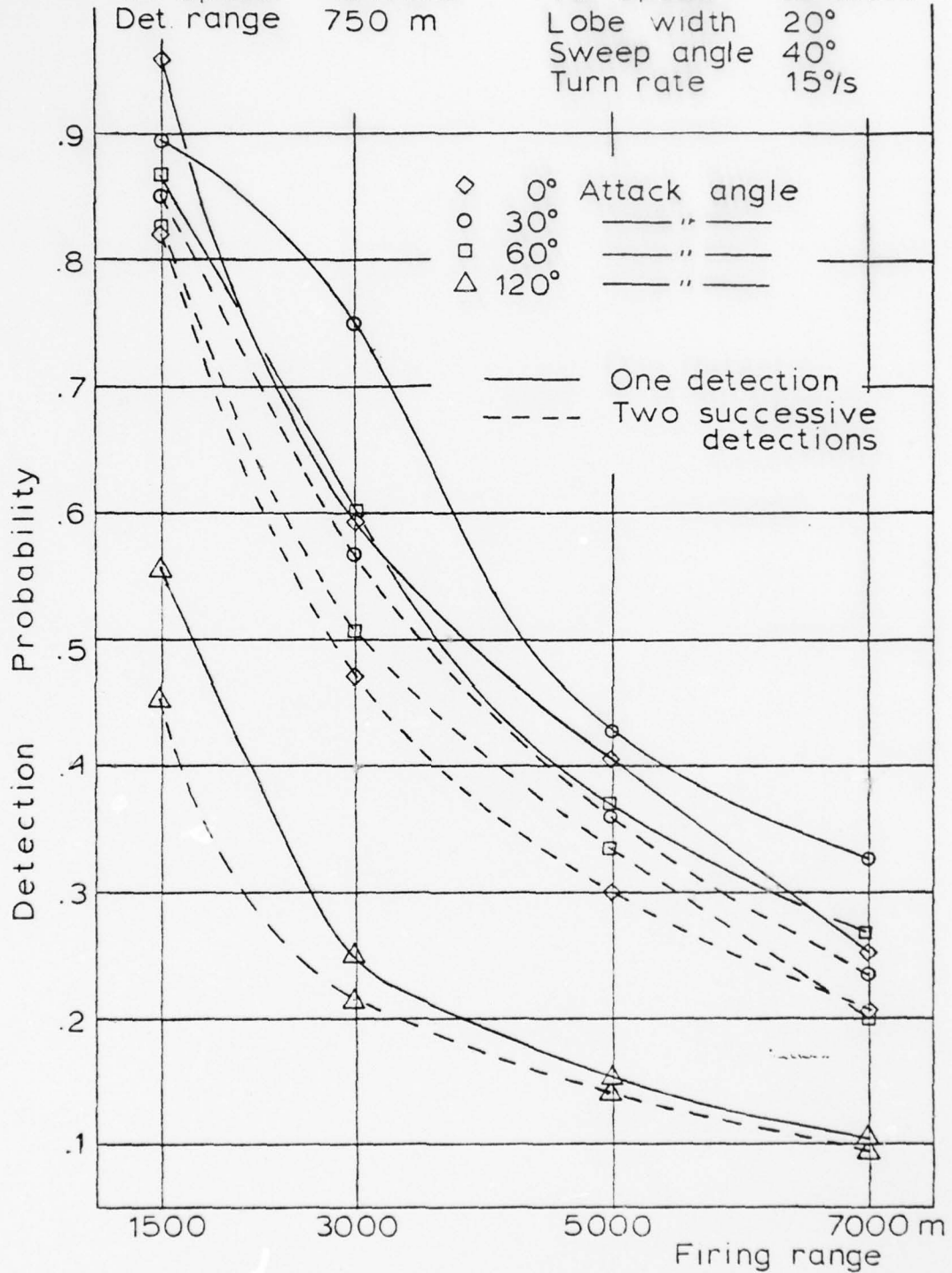

Figure 21 - EFFECT OF FIRING RANGE

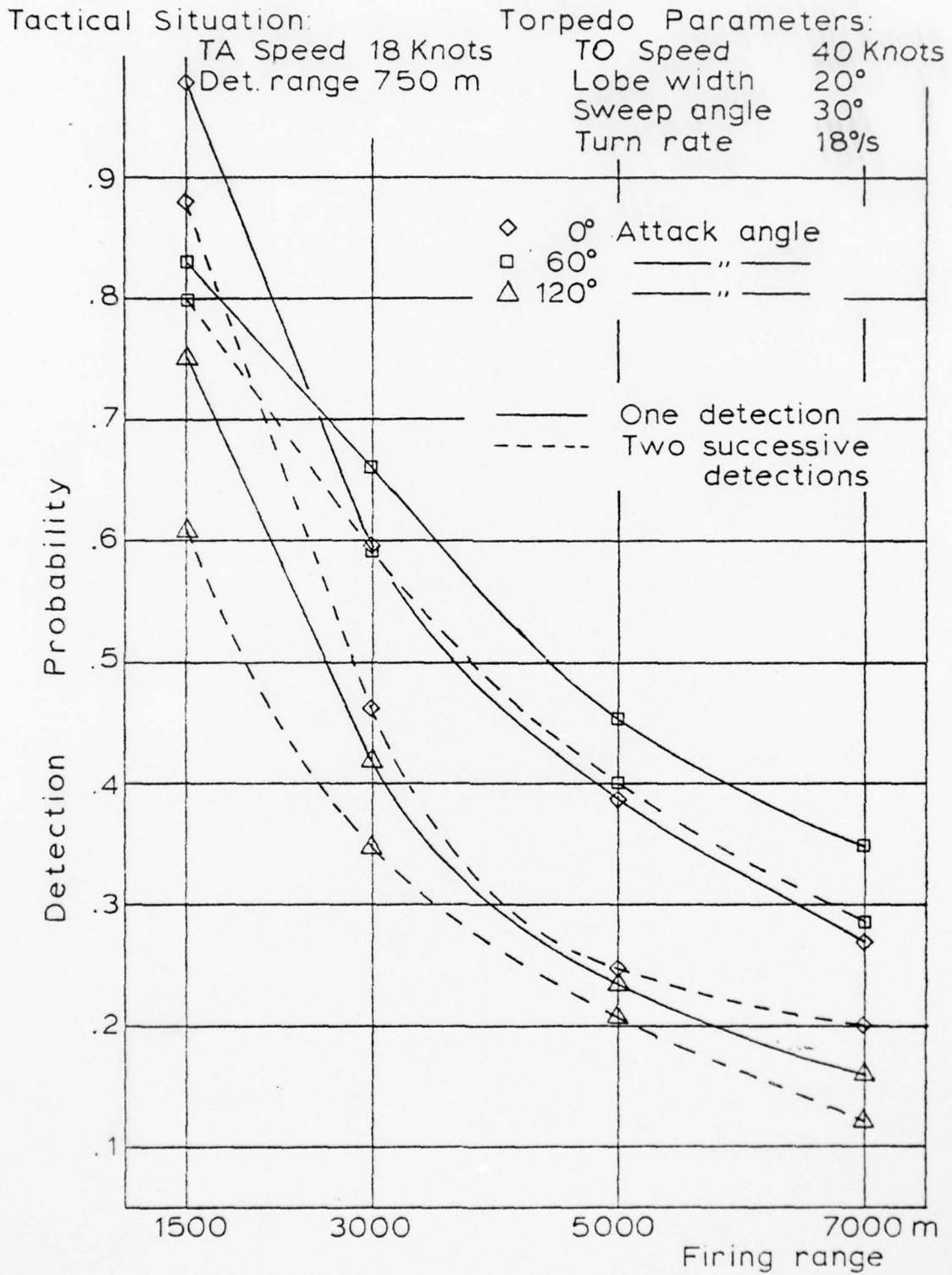

Figure 21.b. - EFFECT OF FIRING RANGE

Torpedo Parameters:

TO Speed 32 40 Knots  
 Lobe width 20 20 °  
 Sweep angle 40 30 °  
 Turn rate 15 18 %/s

Tactical Situation

TA Speed 18 Knots  
 Det. range 750 m

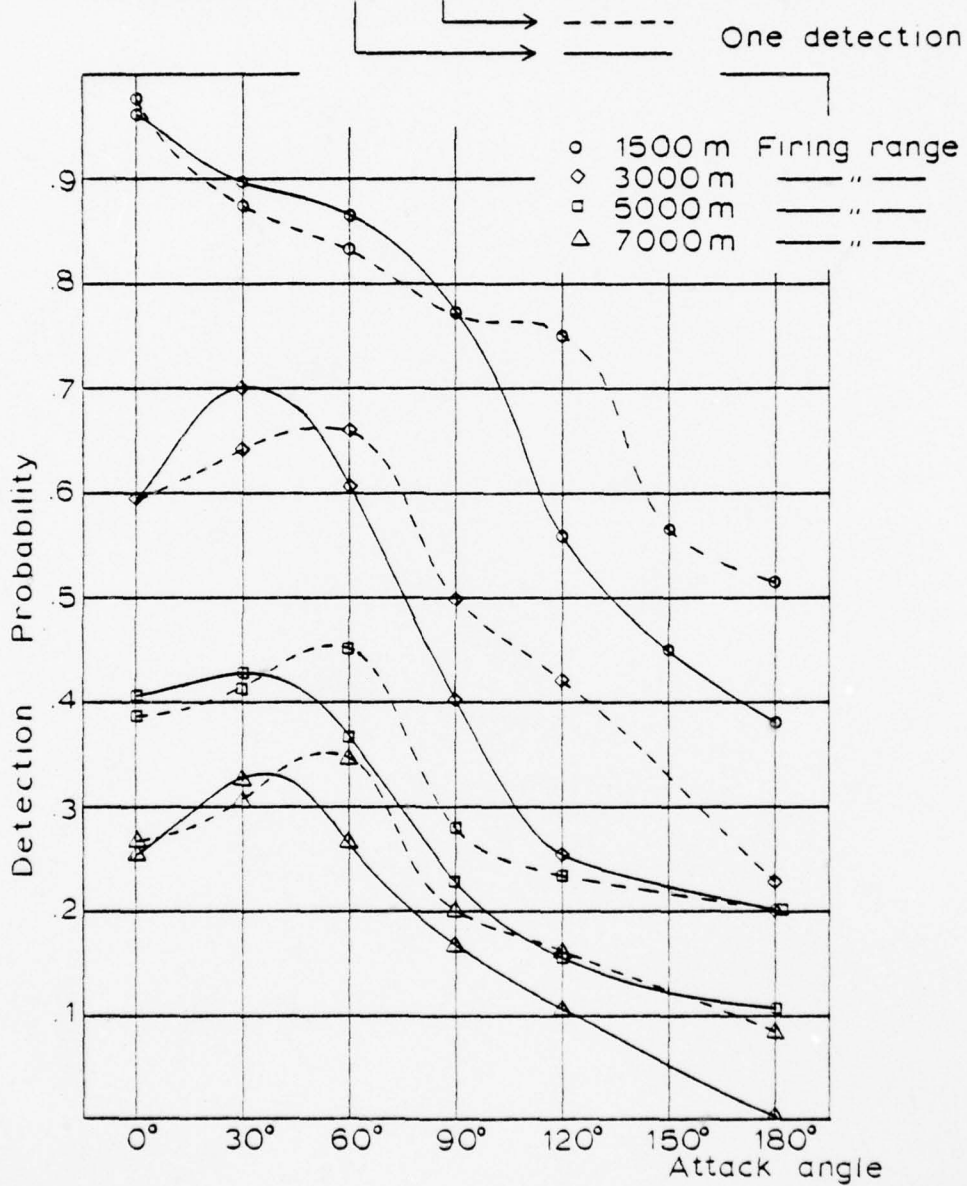

Figure 22 - COMPARISON OF TWO TORPEDOES WITH CHANGE IN FIRING RANGE

Torpedo Parameters

TO Speed 32 40 Knots  
 Lobe width 20 20°  
 Sweep angle 40 30°  
 Turn rate 15 18 %/s

Tactical Situation

TA Speed 18 Knots  
 Det. range 750 m

————— Two successive detections

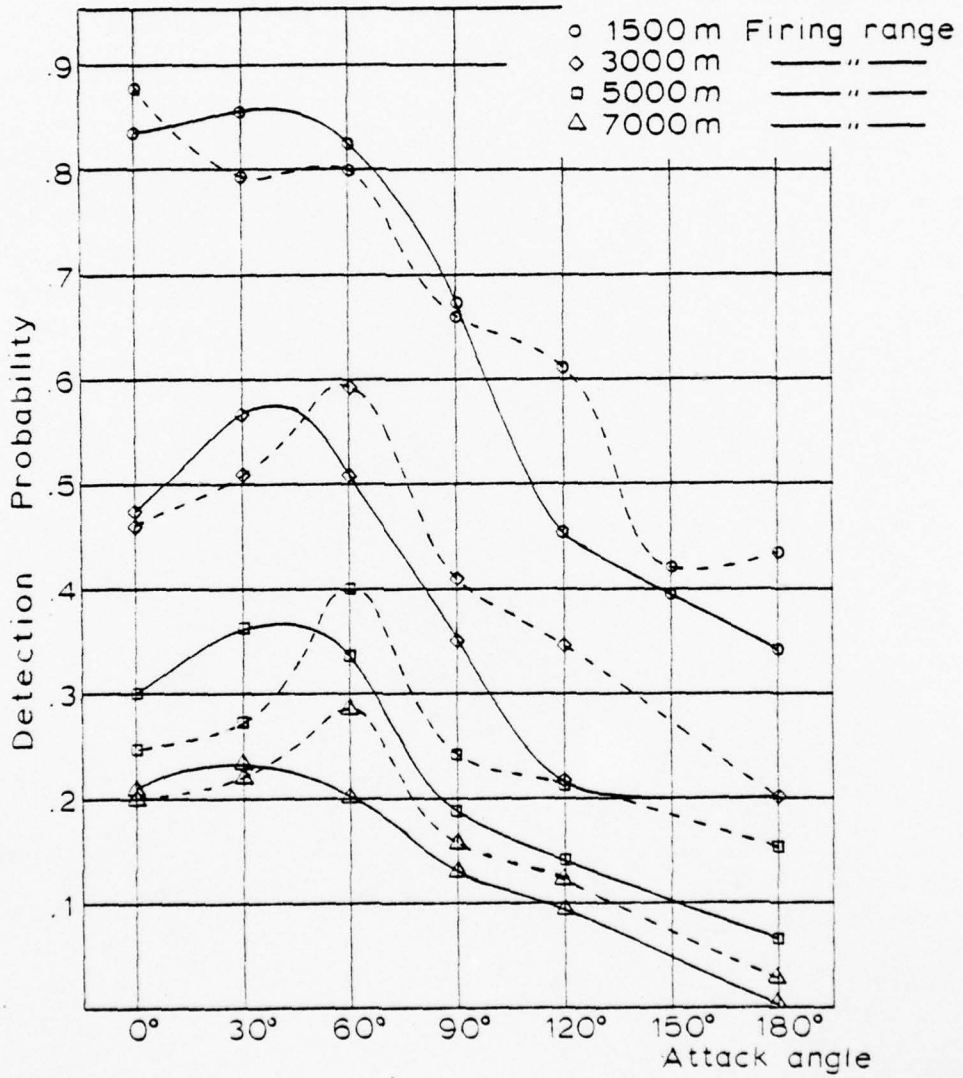

Figure 22.b. - COMPARISON OF TWO TORPEDOES WITH CHANGE IN FIRING RANGE

Tactical situation  
 Target speed 18 knots  
 Detection range 750 m

Torpedo parameters  
 Torpedo speed 32 knots  
 Sweep angle 40 degrees  
 Lobe width 20 degrees  
 Turn rate 15 deg/sec

Attack angle	1 detection			2 detections			3 detections			Range m
	1500	3000	5000	1500	3000	5000	1500	3000	5000	
0	.9600	.5933	.4067	.8333	.4733	.3000	.5600	.3600	.1733	.1000
30	.8933	.7000	.4267	.8533	.5667	.3600	.7533	.3667	.2533	.1800
60	.8667	.6067	.3667	.8267	.5067	.3333	.7267	.4267	.2400	.1867
90	.7733	.4000	.2267	.6733	.3533	.1867	.5333	.2730	.1600	.1200
120	.5600	.2533	.1533	.4533	.2133	.1400	.3467	.1733	.0867	.0533
180	.3800	.2000	.1067	.3400	.2000	.0667	.2667	.1733	.0133	.0000

Tactical situation  
 Target speed 18 knots  
 Detection range 750 m

Torpedo parameters  
 Torpedo speed 40 knots  
 Sweep angle 30 degrees  
 Lobe width 20 degrees  
 Turn rate 18 deg/sec

Attack angle	1 detection			2 detections			3 detections			Range m
	1500	3000	5000	1500	3000	5000	1500	3000	5000	
0	.9800	.5933	.3867	.8800	.4600	.2467	.5200	.2867	.1933	.1533
30	.8733	.6400	.4133	.7933	.5067	.2733	.6800	.3733	.2000	.1600
60	.8333	.6600	.4533	.8000	.5933	.4000	.7333	.4800	.3133	.2000
90	.7667	.4933	.2800	.6600	.4067	.2400	.6000	.2933	.1933	.1333
120	.7533	.4200	.2333	.6133	.3467	.2067	.5000	.2600	.1467	.1000
180	.5133	.2267	.2000	.4333	.2000	.1533	.2867	.2000	.0467	.0000

Table VII - VARIATION IN FIRING RANGE

## J. EFFECT OF TARGET SPEED

Generally, we anticipated a degradation in MOE as the target speed was increased. And overall, this was confirmed.

The simulations were carried through at 12, 18, 24, 30 knots target speed.

However, fig. 23.a and b shows some interesting patterns regarding optimal attack angle for different target speeds. For a 32 knots torpedo, at 60 degrees attack angle, the torpedo is equally good for any type of target speed for one detection only. For two successive detections, the torpedo is equally good between 30 and 90 degrees for 12 and 18 knots target. A 24 knots target gives a consistently lower MOE over the whole range of attack angles, and the 2 simulation runs with a 30 knots target confirmed that trend for the 32 knots torpedo.

We may form the conclusion that for one detection only 60 degrees attack angle is an optimal attack angle for the range of target speeds. For two successive detections, 30 to 90 degrees attack angle gives equally good MOE between target speed of 12 and 18 knots.

One interesting point is that it seems that if the target speed is less than 0.4 of the torpedo speed the optimal attack angle shifts forward to 0 degree. This also applies to two successive detections.

Tactical Situation:  
 Range 3000 m  
 Det. range 750 m

Torpedo Parameters:  
 TO Speed 32 Knots  
 Lobe width 20°  
 Sweep angle 40°  
 Turn rate 15°/s

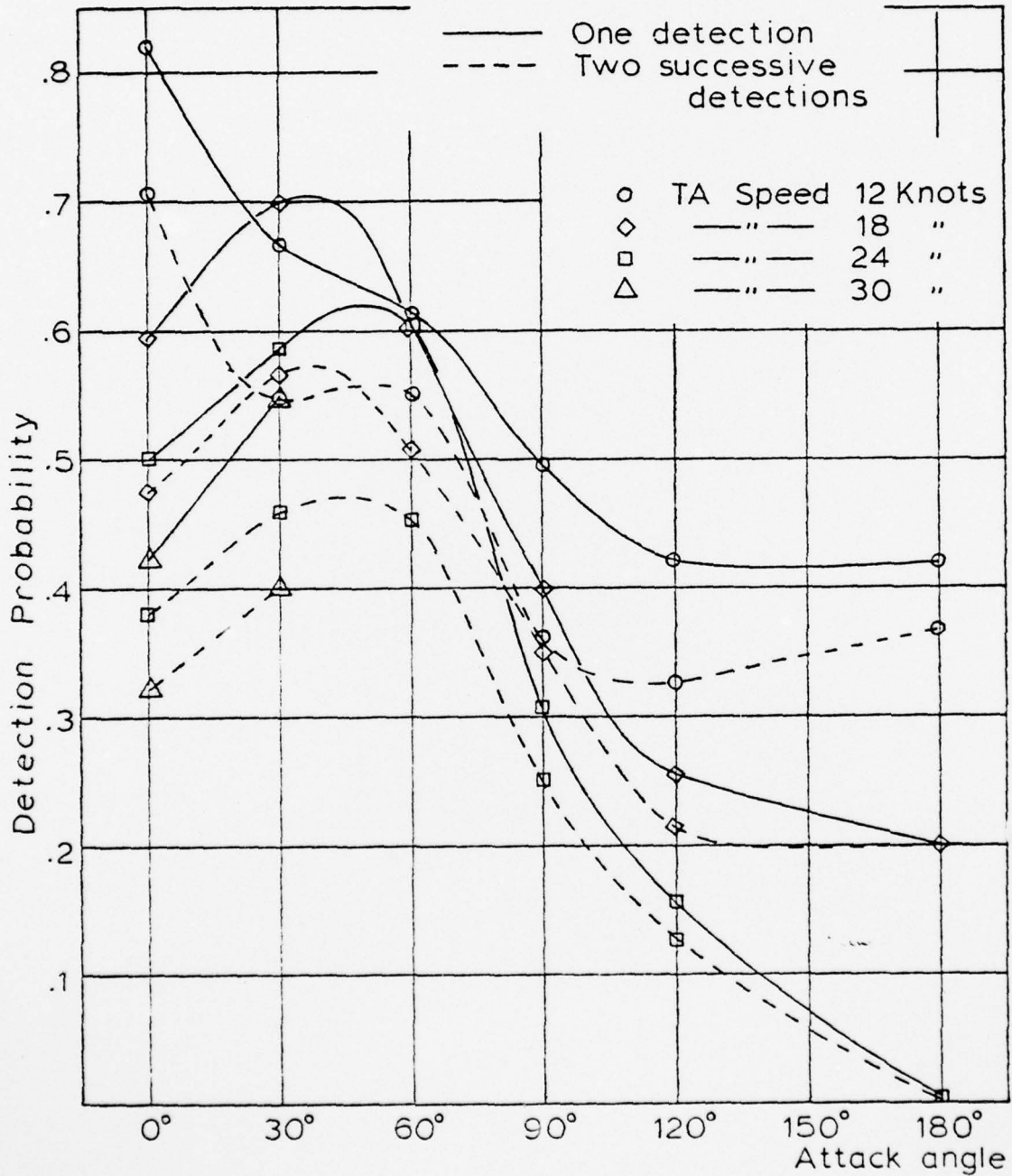

Figure 23 - EFFECT OF TARGET SPEED

Tactical Situation:  
 Range 3000 m  
 Det. range 750 m

Torpedo Parameters:  
 TO Speed 40 Knots  
 Lobe width 20°  
 Sweep angle 30°  
 Turn rate 18°/s

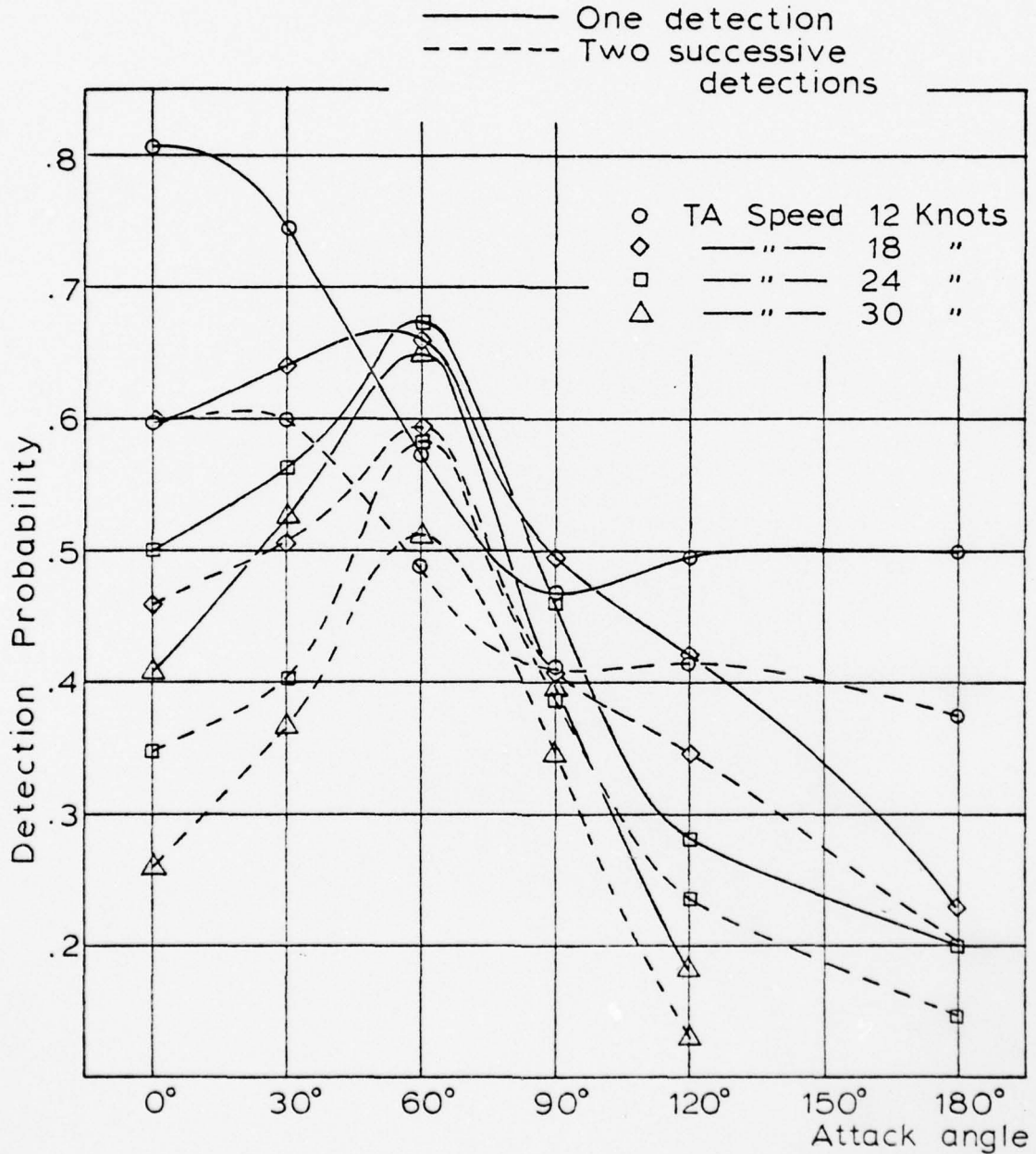
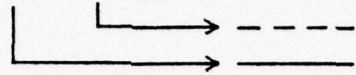

Figure 23.b. - EFFECT OF TARGET SPEED

For a 40 knot torpedo, in addition to the point of optimal attack angle at 0 degree for slow target speeds, we also experienced a relatively low MOE for slow targets in the range 45 to 105 degrees attack angle, compared to fast targets. But as a compensation, MOE is increased for small attack angles and the astern attack angle compared to fast target. Obviously, some type of a breaking point is experienced for target speed of .4 or less of torpedo speed.

Why a slow target produces this increase in MOE in the two extreme cases (ahead and astern) may be explained by the balance between time to reach detection range and the total relative speed. It is, however, more difficult to give any explanation of why a slow target should produce a lower MOE for some attack angles than a faster target does. One would have anticipated an increase in MOE over the whole range of attack angles for a slow target.

Torpedo Parameters:		Tactical Situation:	
TO Speed	32 40Knots	Range	3000m
Lobe width	20 20°	Det. range	750m
Sweep angle	40 30°		
Turn rate	15 18°/s		

 One detection

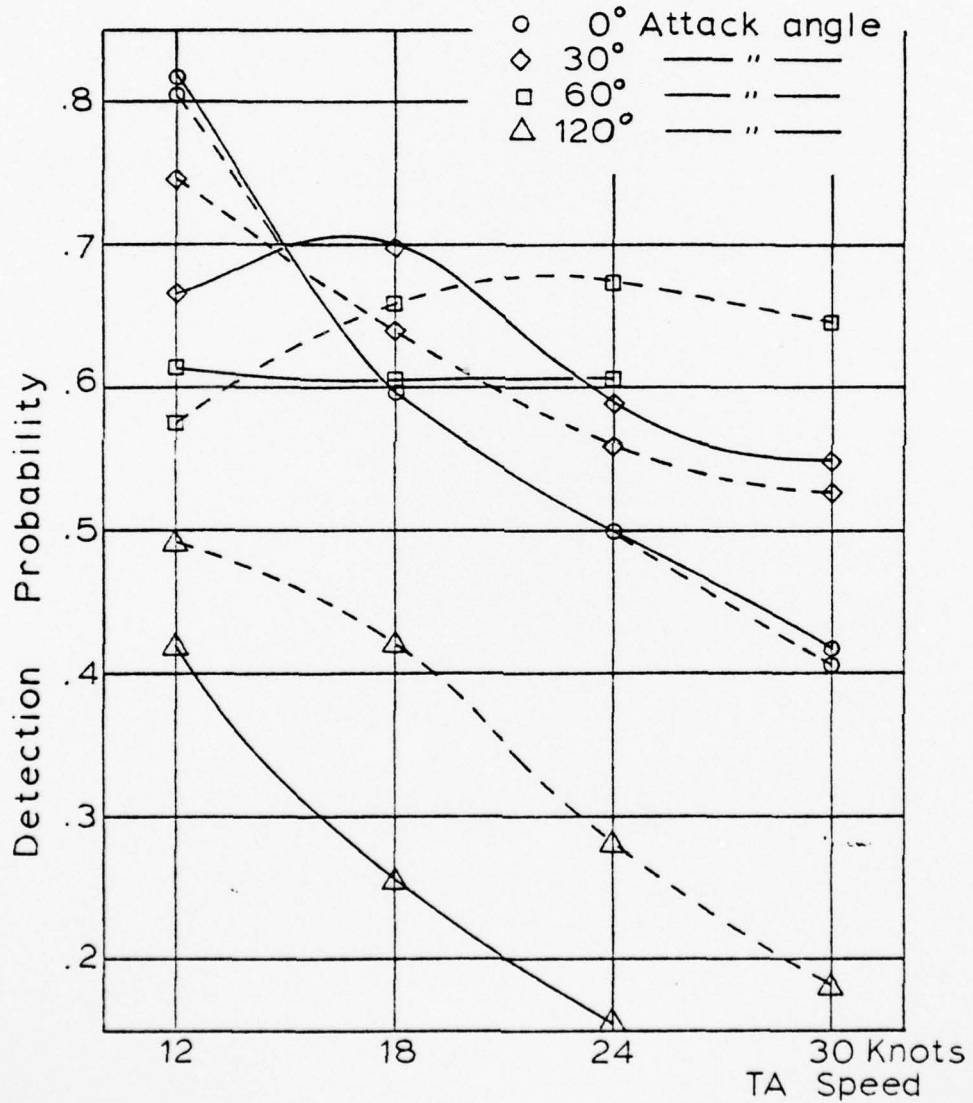

Figure 24 - COMPARISION OF TWO TORPEDOES WITH CHANGE IN TARGET SPEED

Tactical situation  
Range 3000 m  
Detection range 750 m

Torpedo parameters  
Torpedo speed 32 knots  
Sweep angle 40 degrees  
Lobe width 20 degrees  
Turn rate 15 deg/sec

Attack angle	1 detection			2 detections			3 detections			Target speed knots
	12	18	24	12	18	24	12	18	24	
0	.8200	.5933	.5000	.7067	.4733	.3800	.4667	.3600	.2533	.1867
30	.6667	.7000	.5967	.5467	.5667	.4600	.4200	.3667	.3267	.2867
60	.6133	.6067	.6067	.5533	.5067	.4533	.3933	.4267	.3667	
90	.4933	.4000	.3067	.3600	.3533	.2467	.3133	.2730	.2133	
120	.4200	.2533	.1533	.3267	.2133	.1267	.2400	.1733	.1067	
180	.4200	.2000	.0000	.3667	.2000	.0000	.2667	.1733	.0000	

Tactical situation  
Range 3000 m  
Detection range 750 m

Torpedo parameters  
Torpedo speed 40 knots  
Sweep angle 30 degrees  
Lobe width 20 degrees  
Turn rate 18 deg/sec

Attack angle	1 detection			2 detections			3 detections			Target speed knots
	12	18	24	12	18	24	12	18	24	
0	.8067	.5933	.5000	.6000	.4600	.3467	.4133	.2867	.1933	.1400
30	.7467	.6400	.5600	.6000	.5067	.4000	.4267	.3733	.3267	.3267
60	.5733	.6600	.6733	.4867	.5933	.5867	.3600	.4800	.5333	.4267
90	.4667	.4933	.4600	.4067	.4067	.3867	.3200	.2933	.3333	.2667
120	.4933	.4200	.2800	.4133	.3467	.2333	.2333	.2600	.1867	.1000
180	.5000	.2267	.2000	.3733	.2000	.1467	.2467	.2000	.0067	

Table VIII - VARIATION IN TARGET SPEED

## VII. TACTICAL ANALYSIS

In addition to the detailed parametric analysis, which has been shown previously, we also could expand the analysis to cover more tactical related problems. If we assume a given target speed, we could construct detection probability charts as shown in Fig. 25. a. and b.

This analysis would then naturally fall into two areas:

- direct comparison of two or more different types of torpedoes.
- effect of tactical situation on the detection probability.

The two charts (Figs. 25.a. and b.) were formed by running simulation runs for different tactical situations (range and attack angle), and then fitting constant detection probability curves through the data points.

The use of these types of charts falls into two areas: Evaluate different torpedo types for different tactical situations; essentially, which torpedo is best. Or for a given tactical situation, how could the situation be improved, and what options exist.

The first type of use applies mainly to operational planning; operational requirement in the design phase of a torpedo and procurement. By laying one chart atop of the other; we get a visual picture of how much is improved when using a 'better' torpedo, and for which tactical situation. The shaded area in Fig. 25.b. shows how many more tactical situations have been covered when going from a 32 knots torpedo to a 40 knots torpedo for 0.25 detection probability.

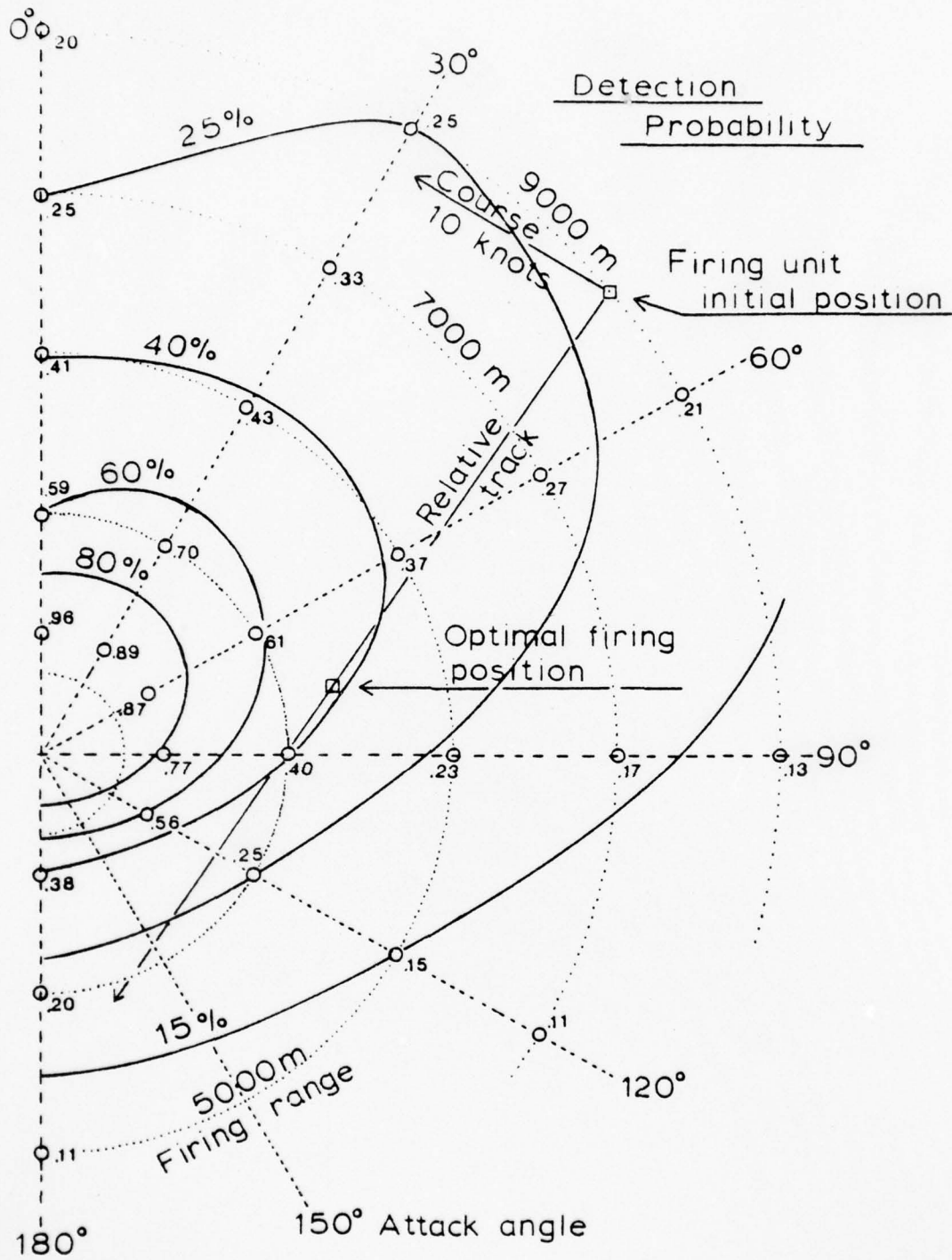

Det. range	750 m	TO Speed	32 Knots
TA Speed	18 Knots	Sweep angle	40°
Turn rate	15 %/s	Lobe width	20°

Figure 25 - EXAMPLE OF TACTICAL GUIDELINES

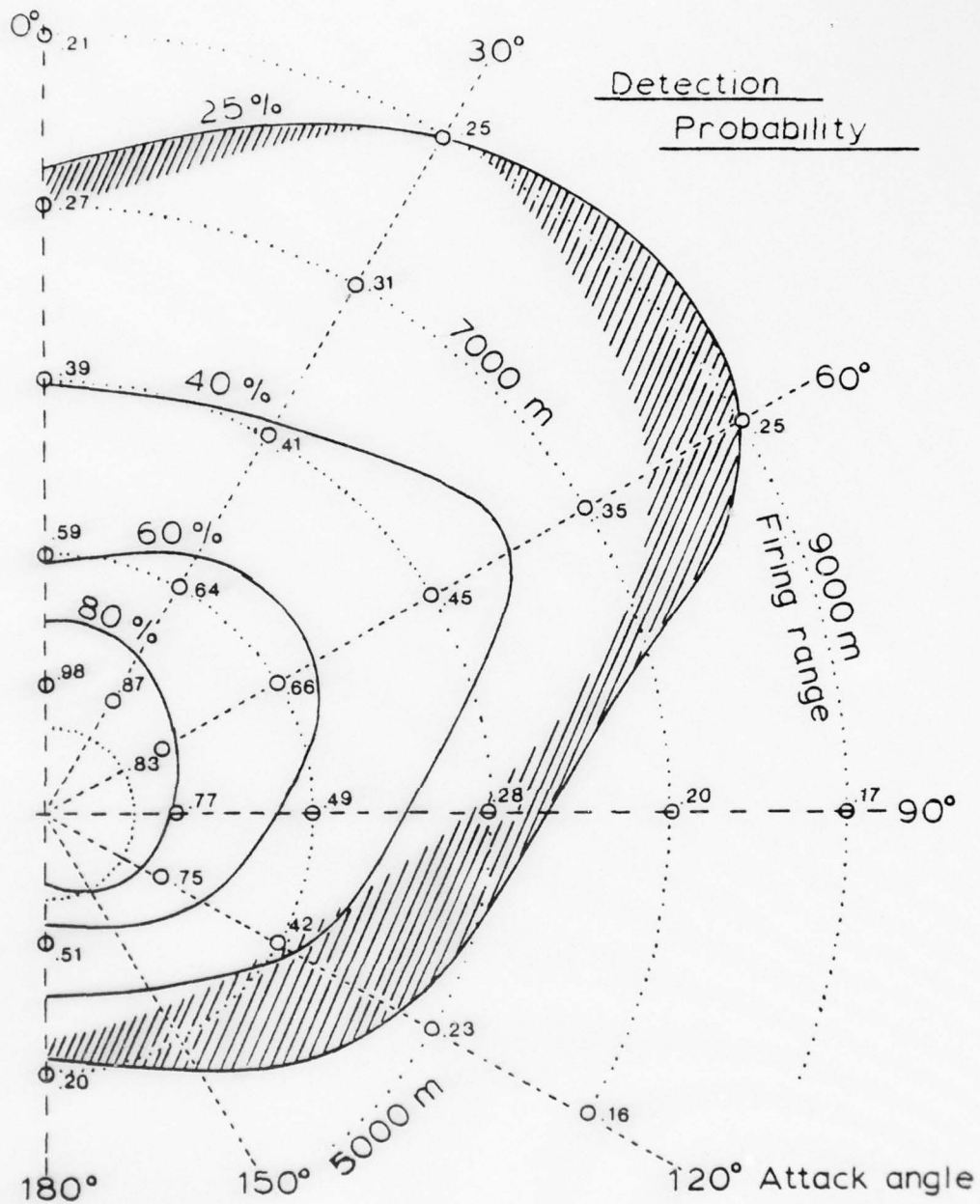

Det. range	750 m	TO Speed	40 Knots
TA Speed	18 Knots	Sweep angle	30°
		Lobe width	20°
		Turn rate	18%

Figure 25.b. - EXAMPLE OF TACTICAL GUIDELINES

AD-A047 265

NAVAL POSTGRADUATE SCHOOL MONTEREY CALIF

F/G 19/8

A HOMING TORPEDO. THE EFFECT OF THE TACTICAL SITUATION AND THE --ETC(U)

UNCLASSIFIED

NL

2 of 2  
ADA047265



END  
DATE  
FILMED  
1 -78  
DDC

The other type of use of the charts is tactical. When a firing unit decides to attack, and finds itself in a given tactical situation, the question is: What to do ?

For given target speed and own max speed, the charts make it possible in a simple way to decide where to go and what course to keep. Also from the charts, one can decide where on the relative course is the optimal firing position. For a submarine attacking a zig-zagging target, the Commanding Officer can better make his evaluation of when to fire, as the attack angle and the distance are continuously changing. He can see what improvement to expect when the target will change course next time. An example of a tactical situation and the course of action to follow are given in Fig. 25.a.

These points also bring up the question of what to improve in the operational picture; the firing unit's ability to achieve a good firing position or the torpedo's ability to detect target from non-optimal situations. In this discussion, the guided torpedo has to be brought into the picture. The effectiveness of guidance has not been addressed at all in this study, basically because that would have significantly expanded the scope of the study, as well as bringing in the whole problem of fire control equipment, its effectiveness and its reliability.

## VIII. CONCLUSIONS

The study was carried out in order to investigate the detection process of an active sonar homing torpedo used against surface ships.

Specifically, we wanted to study the effect of changes in torpedo parameters such as torpedo speed, turn rate, sweep angle and detection range, as well as changes in the tactical situation such as target speed, firing range and attack angle.

In an attempt to gain insight into the complexity of a homing torpedo, the described model was built and the simulations done as previously shown.

In designing a homing torpedo and evaluating torpedo tactics the detection probability is an essential part of the total effectiveness of the torpedo. To be able to hit the target, the torpedo has first to detect it, which justifies why we started out with analyzing the detection process.

Also, as part of this analysis we investigated certain aspect of the next step in the operational process; acquisition.

It is not difficult to visualize tests which may be used in order to recognize an echo as a detection and subsequently a target to attack. Some of these tests may be doppler, successive detections, detections within a given range, 2-of-3 detections, size of echo, length of echo etc.

The problem of false echo, however, was not approached in

this study. That would have to be the next to consider in relation to reducing the number of successive detections in order to acquire a target.

In order to allow for the errors in tracking of the target before firing and also small maneuvering of the target after firing, we introduced errors in the target speed and course when calculation of the torpedo main firing course was done.

During runs the torpedo was unguided, and did not react on any detection; i.e. it did not attack the target. For sonar condition, isovelocity was assumed and no surface effect was built into the model.

The result gave certain insight into the complexity of the detection process, stressing the importance of a good tactical firing position, and a high speed torpedo with long detection range.

However, the data also showed the relationship between detection range, lobe width and turn rate, as well as weighting the sweep angle in relation to torpedo speed. It can also be concluded from the results that changes in torpedo parameters as turn rate and sweep angle, which may be inexpensive modifications, will not give a significant improvement.

Generally, the overall important factor was the time the torpedo used in order to travel within the detection range of the target. This was due primarily to the error generated in the target data, obviously the actual value of the result is sensitive to these assumptions. However, the understanding and insight in the detection process achieved by simulation should not be reduced by other assumptions with regard to error in target data.

With regard to the analysis, the result has shown a consistent and general trend that if we are able to require only one detection for acquiring a target, the detection probability is significantly higher than if more than one detection is required. And what is more important, the potential for improving/optimizing a homing torpedo is also significantly higher for one detection only. This implies a large payoff for other methods of keeping down the probability of false detections.

Secondly, a high speed torpedo has shown a general superiority in MOE. This was specially obvious in attack angles greater than 90 degrees, which tends to make a high speed torpedo more of an all-round/reliable torpedo with regard to tactical situations.

Thirdly, except for changes in attack angle and firing range, the detection range seems to influence the MOE strongly.

These three remarks all point towards an improvement in the sonar-/filtering-area as the most promising area in which to carry out research and invest effort.

This study has also pointed out the advantage of high torpedo speed and firing at short ranges. There exists therefore considerable argument for a short range, high speed torpedo, given that one is able to position the torpedo at a short firing range; i.e. a small, simple torpedo.

Basically, there are two schools of thought;

- a highly sophisticated torpedo; long range, guidance, expensive, but close to the one shot-one hit idea.
- a simple, high speed torpedo; short range,

non-guidance, inexpensive, and requiring either a firing unit which can get into an optimal firing position or a larger number of shots to achieve hit.

The result may be useful in giving example of how tactical guidelines can be evaluated by the simulation approach. But more significant is pointing out the importance of torpedo capability and the tactical situation. Obviously, we have to look on the whole torpedo system, including the firing unit. Investment in resources and effort should not necessarily be spent only on the torpedo in order to increase its effectiveness, but may be spent on the firing unit as well in order to make the unit able to reach a better firing position.

A follow-on of this study may be to investigate the attack process of the torpedo, including the acquisition-and hit-problem.

Then the question of guidance during torpedo run should be analyzed in order to better evaluate the problem of choosing between a few sophisticated, expensive, guided torpedo system or many simple, inexpensive, nonguided torpedo systems.

APPENDIX A

PRINT OUT OF SIMULATION PROGRAM

TCRCC0010  
TCRCC0020  
TCRCC0030  
TCRCC0040  
TCRCC0050  
TCRCC0060  
TCRCC0070  
TCRCC0080  
TCRCC0090  
TCRCC0100  
TCRCC0110  
TCRCC0120  
TCRCC0130  
TCRCC0140  
TCRCC0150  
TCRCC0160  
TCRCC0170  
TCRCC0180  
TCRCC0190  
TCRCC0200  
TCRCC0210  
TCRCC0220  
TCRCC0230  
TCRCC0240  
TCRCC0250  
TCRCC0260  
TCRCC0270  
TCRCC0280  
TCRCC0290  
TCRCC0300  
TCRCC0310  
TCRCC0320  
TCRCC0330  
TCRCC0340  
TCRCC0350  
TCRCC0360  
TCRCC0370  
TCRCC0380  
TCRCC0390  
TCRCC0400  
TCRCC0410  
TCRCC0420  
TCRCC0430  
TCRCC0440  
TCRCC0450  
TCRCC0460  
TCRCC0470  
TCRCC0480  
TCRCC0490

```

A TCRPECC SIMULATION. HCMING TORPECC DURING SEARCH.
SIMULATING AN ACTIVE HCMING TORPECC DURING SEARCH.
THE PROGRAM IS RUN IN 0.5 SEC STEPS.
COMMON ISEEC21, TTIME, TC, TA, TRATE, RANGE, ALFA, LAMEC, TACEC,
*EEAR, RAD, TAG, CCOR, DEV, SP, BNG, FN, PH2, ACCURS, TCCURS,
*MXM, MXM, INTVAL, ICTIME, ITIME, XT, XTAR, YSTAR, CIST, MCIST,
*TLRKN, TC, INTVAL, PHI,
CCMNCN/TARGET/TACMG, TAM1, RNMCC, LA1, COUR, CE(10), SE(15), JRUN,
*IFLAG, CA2, RM(5,5), VAR(5), DET(150,5), DETB(150,5), STC(5),
*TIMPEC(150,5), DERB(150,5), CLCSB(150,5), KCN(150,5),
REAL LAMBC, MCOURS, MXM, MXM, MCIST, LAMECC
INTEGER RUNCLT

SETTING OF CONSTANTS (STEP 1)
CALL CVFLCM
PH1=3.141592654
PH2=2.*PH1
RAC=PH2/360
ISEED1=362776
ISEED2=561655
LCRREC=1
CCRREC=15
CCCF=CCRREC*RAD
LSPREC=1
LCRREC=2
DEV=LCRREC*0.5
ICTIME=1

SET NUMBER OF ITERATIONS
IFUN=150

SET PRINT CLT MCDE
IFPRINT=1

SET LCBE OFF TCRPECC CENTER BEARING
CFLCB=0.

SET TABLES TO ZERC (STEP 2)
CC J1 I=1, 5
CC J2 J=1, 5
RM(I, J)=C.
CONTINUE
CC J3 J=1, 5
CC J4 I=1, 5
KCN(I, J)=0

```

TCR000490  
 TCR000510  
 TCR000520  
 TCR000530  
 TCR000540  
 TCR000550  
 TCR000560  
 TCR000580  
 TCR000590  
 TCR000600  
 TCR000610  
 TCR000620  
 TCR000630  
 TCR000640  
 TCR000650  
 TCR000660  
 TCR000670  
 TCR000680  
 TCR000690  
 TCR000700  
 TCR000710  
 TCR000720  
 TCR000730  
 TCR000740  
 TCR000750  
 TCR000760  
 TCR000770  
 TCR000780  
 TCR000790  
 TCR000800  
 TCR000810  
 TCR000820  
 TCR000830  
 TCR000840  
 TCR000850  
 TCR000860  
 TCR000870  
 TCR000880  
 TCR000890  
 TCR000900  
 TCR000910  
 TCR000920  
 TCR000930  
 TCR000940  
 TCR000950  
 TCR000960

```

14 CCNTINUE TARGET ERRORS AND STCRE
13 CC 20 I=1, IC
C CC(1)=-((15.*RAD+CCCR/10.)+(CCOR/10.))*I*2.
20 CCNTINUE
SS(1)=-1.8737*DEVSP
SS(2)=-1.2825*DEVSP
SS(3)=-1.568*DEVSP
SS(4)=-1.7285*DEVSP
SS(5)=-1.525*DEVSP
SS(6)=-1.34*DEVSP
SS(7)=-1.1675*DEVSP
SS(8)=-1.1675*DEVSP
SS(9)=-1.1675*DEVSP
SS(10)=-1.34*DEVSP
SS(11)=-1.525*DEVSP
SS(12)=-1.7285*DEVSP
SS(13)=-1.568*DEVSP
SS(14)=-1.2825*DEVSP
SS(15)=-1.8737*DEVSP

C 100 CC 500 JRUN=1, IRUN
C SET RUN CCOUNTERS (STEP 3)
C IFLAG=1; TCC LGM TCRPEDD SPEED
C IFLAG=0
C ICCNT=0
C JCCNT=0
C JTIME=0
C ILC=0
C ICST=0.
C IXT=0.
C IXP=0.
C RUNCLT=C

C REAC IN SETTING(TCRP AND TACTICAL)
C FIRST RUN ? (STEP 4)
C IF(JRUN.GT.1)GO TO 160
C CALL PAFMET

C WRITE(6,228)ICLCLB
C FCMPAT(IX,/,IX,SCNAR,MAIN,LCLBE,CFF-SET,FRCN,CENTER,/,
228 * BEARING,/,FC-2,/,TIMES,DEFLECTION,ANGLE,/,/)

```



TORC145C  
 TOR0146C  
 TOR0147C  
 TOR0148C  
 TOR0149C  
 TOR0150C  
 TOR0151C  
 TOR0152C  
 TOR0153C  
 TOR0154C  
 TOR0155C  
 TOR0156C  
 TOR0157C  
 TOR0158C  
 TOR0159C  
 TOR0160C  
 TOR0161C  
 TOR0162C  
 TOR0163C  
 TOR0164C  
 TOR0165C  
 TOR0166C  
 TOR0167C  
 TOR0168C  
 TOR0169C  
 TOR0170C  
 TOR0171C  
 TOR0172C  
 TOR0173C  
 TOR0174C  
 TOR0175C  
 TOR0176C  
 TOR0177C  
 TOR0178C  
 TOR0179C  
 TOR0180C  
 TOR0181C  
 TOR0182C  
 TOR0183C  
 TOR0184C  
 TOR0185C  
 TOR0186C  
 TOR0187C  
 TOR0188C  
 TOR0189C  
 TOR0190C  
 TOR0191C  
 TOR0192C

```

DETE(JRUN,J)=0.
DET(JRUN,J)=0.
ASPEC(JRUN,J)=0.
CLCSB(JRUN,J)=0.
CERE(JRUN,J)=0.
CCNTINUE
CC TO 900
IF(IIFLAG.EC. 1)GC TO 950
IF(MXT.GE. TRANGE)RLNCUT=1
IF(RUNOUT.EQ. 1)GC TO 990

C CALCULATE NEW POSITIONS
CALL PCSIS

C CHECK IF TARGET IS DETECTED
CALL DETECT

C CHECK CPA(CLOSEST POINT OF APPROACH) (STEP 6)
IL=IL+1
IF(IL.LE. 20)GO TC 500
IL=0
CPA=DIST
IF(CPA1-CPA.LE. 0.)RUNOUT=1
CPA1=CPA
GC TC 500

C GENERATE STATISTICS (STEP 9)
CCNTINUE
CC 510 IKL=1,5

KCN( ) = DETECTION/NO DETECTION
IF(FMAX(IKL,1) .GT. 1.)KON(JRUN,IKL)=1

DEL( ) = DISTANCE TC TARGET AT DETECTION
DET(JRUN,IKL)=RMAX(IKL,1)

DETB( ) = BEARING TC TARGET AT DETECTION
DETE(JRUN,IKL)=RMAX(IKL,2)

ASPEC( ) = TARGET ASPECT AT DETECTION
ASPEC(JRUN,IKL)=RMAX(IKL,5)

CLCSB( ) = BEARING TC CLOSEST PART OF TARGET
CLCSE(JRUN,IKL)=RMAX(IKL,4)

CERE( ) = REL BEARING FROM MAIN TCRP COURSE TC TARGET
CERE(JRUN,IKL)=RMAX(IKL,6)
CCNTINUE
51C

```



```

TCR0241C
TCR0242C
TCR0243C
TCR0244C
TCR0245C
TCR0246C
TCR0247C
TCR0248C
TCR0249C
TCR0250C
TCR0251C
TCR0252C
TCR0253C
TCR0254C
TCR0255C
TCR0256C
TCR0257C
TCR0258C
TCR0259C
TCR0260C
TCR0261C
TCR0262C
TCR0263C
TCR0264C
TCR0265C
TCR0266C
TCR0267C
TCR0268C
TCR0269C
TCR0270C
TCR0271C
TCR0272C
TCR0273C
TCR0274C
TCR0275C
TCR0276C
TCR0277C
TCR0278C
TCR0279C
TCR0280C
TCR0281C
TCR0282C
TCR0283C
TCR0284C
TCR0285C
TCR0286C
TCR0287C
TCR0288C

```

```

27 CCNTINLE
C CC 520 KK=1,5
C CCMFLTING MEANS
C DEL=RM(KK,1)
C IF(LE.(KK,2))DEL=1.
C RM(KK,2)=RM(KK,3)/DEL
C RM(KK,3)=RM(KK,4)/DEL
C RM(KK,4)=RM(KK,5)/DEL
C CCNTINLE
920
C CC 25 KK=1,5
C VAR(KK)=0.
C IF(170 I=1, IRUN
C IF(KCN(I, KK).EQ. C)GO TO 170
C VAR(KK)=VAR(KK)+(DEL(I, KK)-RM(KK, 2))**2)
C CCNTINLE
17C
25 CC 26 KR=1,5
C DEL=RM(KR,1)
C IF(LE.(KR,2))DEL=2.
C STC(KR)=SQRT(VAR(KR))/(DEL-1.)
C RM(KR,1)=RM(KR,1)/FLCAT(IRUN)
C CCNTINLE
26
C C
C C
197 PRINT SUMMARY (STEP 13)
195 FCFMAT(IX,5)SUMMARY CF RESULT AFTER,3X,I4,2X,'FUNS.'
FCFMAT(IX,5)RM(I,J),J=1,2),STC(I),J=3,5),I=1,5)
FCFMAT(IX,5)PROBABILITY OF DETECTION,8X,
*7X,AVERAGE,4X,STDEV,7X,AVERAGE,
*7X,REL BEARING,6X,DET RANGE,7X,TARGET ASPECT,4X,DET BEARING,
*IX,CNE SUCCESSIVE DETECTIONS,5X,F6.4,5(6X,F5.4) //,
*IX,TWO SUCCESSIVE DETECTIONS,4X,F6.4,5(6X,F5.4) //,
*IX,THREE SUCCESSIVE DETECTIONS,3X,F6.4,5(6X,F5.4) //,
*IX,FOUR SUCCESSIVE DETECTIONS,2X,F6.4,5(6X,F5.4) //,
*IX,FIVE SUCCESSIVE DETECTIONS,1X,F6.4,5(6X,F5.4) //
FCFMAT(IX,5)NO DETECTION
C F2=CA2/FLCAT(IRUN)
WRITE(6,15C)DA2
19C FCFMAT(IX,5)AVERAGE DEFLECTION ANGLE :,5X,F8.4, //
WRITE(6,234)
234 FCFMAT(IX,5)DISTRIBUTION OF RUN RESULT - CENTER CF TARGET, //,

```

```

TORC285C
TORC290C
TORC295C
TORC299C
TORC300C
TORC301C
TORC302C
TORC303C
TORC304C
TORC305C
TORC306C
TORC307C
TORC308C
TORC309C
TORC310C
TORC311C
TORC312C
TORC313C
TORC314C
TORC315C
TORC316C
TORC317C
TORC318C
TORC319C
TORC320C
TORC321C
TORC322C
TORC323C
TORC324C
TORC325C
TORC326C
TORC327C
TORC328C
TORC329C
TORC330C
TORC331C
TORC332C
TORC333C
TORC334C
TORC335C
TORC336C

```

```

*6X, *CNE SUCCESSIVE DETECTION, 10X, *TWO SUCCESSIVE DETECTIONS,
*8X, *THREE SUCCESSIVE DETECTIONS, 7,
*2X, *BEAR, 2X, *RANGE ASPECT BEAR, *CLOS, 6X, *BEAR, 2X,
* *RANGE ASPECT BEAR CLCS, 5X, *BEAR, 2X,
* *RANGE ASPECT BEAR CLCS, 5
WRITE(6,236)((DETB(I,1)),DET(I,1),ASPEC(I,1),CLCSE(I,1),
*DETE(I,1,2),DET(I,2),ASPEC(I,2),CLCSB(I,2),DETB(I,3),
*DET(I,3),ASPEC(I,3),CLCSB(I,3)),I=1,IRUN)
FCRMMAT(3(1X,F6.1,1X,F6.1,1X,F6.1,2X,F6.1,5X))
STCP
ENC
C
236
599
C
C
C
C
SLROUTINE PARMET
REACING IN DATA AND PARAMETERFS
COMMON ISEEC2, TTIME, TC, TA, TRATE, RANGE, ALFA, LAMED, TADCC,
BEAR, RAD, TAC, CCCR, DEVSP, BNG, FN, PHZ, MCLCS, TCCURS,
*MXI, MXT, IK, IDTIME, ITIME, XT, YI, XTAR, YIAR, ICIST,
*MCIST, TURNTO, INTVAL, PHI, RMAX(5,6), TRANCE, DIST, IPRINT
REAL LAMBC, MCOURS, MXT, MXM, MCIST, LAMBCG
INTEGER RUNCT
TECEC - TECHNICAL DETECTION RANGE (STEP A1)
LEVEL OF VARIATION: 375-750-1125-1500 METERS
TADCC - TACTICAL DETECTION RANGE
TECEC=750
TADCC=TEDEC
TTIME - TRANSMISSION INTERVAL
TTIME=2.*TEDEC/1500.
TCKN - TORP SPEED IN KNOTS, TO - TCRP SPEED IN M/SEC (STEP A2)
LEVEL OF VARIATION: 24-32-40 KNOTS
TCKN=40.
TC=TCKN/2
TAKN - TARGET SPEED IN KNOTS, TA - TARGET SPEED IN M/SEC (STEP A3)
LEVEL OF VARIATION: 12-18-24-30 KNOTS
TAKN=18.
TA=TAKN/2
TACG - TARGET COURSE IN DEGREE (STEP A4)
TACG=270
TAC=TACG#RAC
C
C
C
C
ALFAG - SWEEP ANGLE IN DEGREE, ALFA - SWEEP ANGLE IN RADIANS

```

```

C C (STEP A5)
C C LEVEL CF VARIATION: 20-30-40 DEGREES
C C ALFAG=30
C C ALFA=ALFAG*RAD
C C LAMEDG - LCBE WICHT EACH SIDE CF TCRP HEADING (STEP A6)
C C LAMEDG=20
C C LAMED=LAMEDG*RAD
C C RELBRG - RELATIVE BEARING FROM TARGET TO TORP IN DEGREE (STEP A7)
C C LEVEL OF VARIATION: 0-30-60-90-120-180 DEGREES
C C RELBRG=-60
C C RELBR=RELBRG*RAD
C C RANGE - DISTANCE BETWEEN TARGET AND TCRP (STEP A8)
C C LEVEL CF VARIATION: 1500-3000-5000-7000 METERS
C C RANGE=3000
C C TRANGE - MAX TCRP RUN IN METERS (STEP A9)
C C TRANGE=18000
C C TRATEG - TCRP TURNRATE IN DEGREE PER SEC (STEP A10)
C C LEVEL OF VARIATION: 3-6-9-12-15-18-21 DEGREE/SEC
C C TRATEG=18
C C TRATE=TRATEG*RAD
C C CALCULATE WIDTH OF TACTICAL SWEEP-LANE (THEORETICAL)
C C SRNG=TALDEC*SIN(ALFA+LAMBDA)*2
C C CALCULATE CCVERAGE RATIO (THEORETICAL)
C C CRATIO=1-((TRATE*TIME)/(2.*LAMBDA))
C C PRINT OF SITUATION AT START CF RUN (STEP A12)
C C IF(IPRINT.EQ.0)GC TO 90
C C WRITE(6,11C)
C C *FCFMAT(1X,7/,1X,'TACTICAL SITUATION WHEN FIRING',6X,
C C *TCRPELCC PAFAMETER',TARGET TARGET',6X,'SEC,SET TORP',
C C *2X,'RANGE ATTACK SWEEP',7X,'CCVERAGE',
C C *3X,'SWEEP LOBE COURSE TURN SPEED',4X,'RANGE SPEED',2X,
C C *5X,'ANGLE WIDTH RATE LANE',4X,'RATIO')
C C *WRITE(6,112)RANGE,RELBRG,TACG,TAKN,TEDEC,TCMN,ALFAG,
C C *LAMEDG,TRATEG,SRNG,CRATIO
C C *FCFMAT(1X,F6.0,2X,F6.1,3X,F5.1,3X,F6.1,3X,F5.1,3X,
C C *F4.1,2X,F4.1,2X,F6.1,3X,F5.3)
C C GC TO 55
C C WRITE(6,1CC)

```

```

TORC337C
TCR0338C
TCR0339C
TCR0340C
TCR0341C
TCR0342C
TCR0343C
TCR0344C
TCR0345C
TCR0346C
TCR0347C
TCR0348C
TCR0349C
TCR0350C
TCR0351C
TCR0352C
TCR0353C
TCR0354C
TCR0355C
TCR0356C
TCR0357C
TCR0358C
TCR0359C
TCR0360C
TCR0361C
TCR0362C
TCR0363C
TCR0364C
TCR0365C
TCR0366C
TCR0367C
TCR0368C
TCR0369C
TCR0370C
TCR0371C
TCR0372C
TCR0373C
TCR0374C
TCR0375C
TCR0376C
TCR0377C
TCR0378C
TCR0379C
TCR0380C
TCR0381C
TCR0382C
TCR0383C
TCR0384C

```



TORC4330  
 TOK04340  
 TORC4350  
 TORC4360  
 TORC4370  
 TORC4380  
 TORC4390  
 TCR04400  
 TORC4410  
 TORC4420  
 TORC4430  
 TORC4440  
 TORC4450  
 TORC4460  
 TORC4470  
 TORC4480  
 TCR04490  
 TORC4500  
 TORC4510  
 TORC4520  
 TORC4530  
 TORC4540  
 TORC4550  
 TORC4560  
 TORC4570  
 TORC4580  
 TORC4590  
 TORC4600  
 TORC4610  
 TORC4620  
 TORC4630  
 TORC4640  
 TORC4650  
 TORC4660  
 TORC4670  
 TORC4680  
 TORC4690  
 TORC4700  
 TORC4710  
 TORC4720  
 TORC4730  
 TORC4740  
 TORC4750  
 TORC4760  
 TORC4770  
 TORC4780  
 TORC4790  
 TORC4800

```

C      IF(TACM .LT. 0.)TACM=PH2+TACM
C      CALCULATE EST OF TARGET SPEED (STEP B2)
C      TAN=TA+SE(KSPEED)
C      CALCULATE TORPEDO DEFLECTION ANGLE (STEP B3)
C      ASF=BEAR-DIFCO
C      IF(ASP .LT. -PHI)ASP=PH2+ASP
C      TACS=TAN*SIGN(ABS(ASP))
C      CA=TA+TACS/TC
C      IF(DAA .GE. 1.)GC TO 26
C      CA=AR SIN(CAA)
C      CA=SIGN(DA,ASP)
C      CALCULATE TORPEDO MAIN FIRING CCOURSE (STEP E4)
C      MCCURS=BNG+PHI+DA
C      IF(MCCURS .GT. PH2)MCCURS=MCCURS-FH2
C      IF(MCCURS .LT. 0.)MCCURS=PH2+MCCURS
C      IF(MCCURS .GT. PH2)GO TO 10
C      CALCULATE TORPEDO PRESENT FIRING CCOURSE (STEP B5)
C      DIFALF=(U1)*2.*ALFA)-ALFA
C      TCCLRS=MCCURS+DIFALF
C      IF(TCCLRS .GT. PH2)TCCLRS=TCCLRS-FH2
C      IF(TCCLRS .LT. 0.)TCCLRS=PH2+TCCLRS
C      IF(DIFALF .GE. 0.)PN=-PN
C      CALCULATE ESTIMATE OF TARGET RANGE (STEP B6)
C      RNCCLIF=(1.-U(2))*RANGE*0.15
C      TACMGC=TACM/RAD
C      TAP1=TAN*2
C      CA1=CA/RAD
C      CA2=(CA2+DA)
C      PRINT CLT CF FIRING DATA
C      IF(IPRINT .EQ. 1)GO TO 25
C      WRITE(6,12)TACMGC,TAP1,RNGMGC
C      FCFMAT(1X,'EST OF TARGET DATA FOR FIRING',/,
122 *4X,'COURSE',5X,'SPEED',6X,'RANGE',/,
      *1X,2(F8.1,3X))
C      WRITE(6,12)DA1
124 *FCFMAT(1X,'TORPEDO DEFLECTION ANGLE IS ',F6.2)
C      FCCLR=MCCURS/RAD
C      WRITE(6,12)TCOUR
125 *FCFMAT(1X,'TORPEDO MAIN COURSE',8X,F6.2)
126 CCNTINUE

```





```

C          CENTB - BEARING OF CENTER OF LCEE (STEP E6)
C          CC=-CA*CELCB
C          CENTB=TC CCURS+DD
C          IF(CENTB .LT. 0)CENTB=PH2+CENTE
C          IF(CENTB .GT. PH2)CENTB=CENTB-PH2
C          CALCULATE BEARINGS TO TARGET (STEP D7)
C          RE=ECARIN(XTAR1,YTAR1,XT,YT)
C          XTAR2=XTAR1+SIN(TAC)*A/2.
C          YTAR2=YTAR1+COS(TAC)*A/2.
C          DIST1=SQRT((XTAR2-XI)**2 + (YTAR2-YI)**2)
C          RE1=BEARIN(XTAR2,YTAR2,XT,YI)
C          XTAR3=XTAR1-SIN(TAC)*A/2.
C          YTAR3=YTAR1-COS(TAC)*A/2.
C          DIST2=SQRT((XTAR3-XI)**2 + (YTAR3-YI)**2)
C          RE2=BEARIN(XTAR3,YTAR3,XT,YI)
C          REL1=RE1-CENTB
C          IF(REL1 .GT. PHI)REL1=REL1-PH2
C          IF(REL1 .LT. -PHI)REL1=PH2+REL1
C          RELC=RE-CENTB
C          IF(RELO .GT. PHI)RELO=RELO-PH2
C          IF(RELO .LT. -PHI)RELO=PH2+RELO
C          REL2=RE2-CENTB
C          IF(REL2 .GT. PHI)REL2=REL2-PH2
C          IF(REL2 .LT. -PHI)REL2=PH2+REL2
C          CALCULATE TRANSMISSION GAIN FACTOR (STEP E8)
C          RE1=RELC
C          RE2=RELO
C          ALAM=LAMBDA
C          COMPUTE SEPARATE GAIN FACTORS (STEP D9)
C          X1=XFACT(RBX1,ALAM)
C          X2=XFACT(RBX2,ALAM)
C          X3=XFACT(RBX3,ALAM)
C          X11=(X1+X2+X3)/3.
C          CALCULATE TARGET ASPECT AND TARGET SONAR CROSS-
C          AREA (TARGET STRENGTH) DUE TO ASPECT (STEP E10)
C          ANTRB=RE+PHI
C          IF(ANTRB .GT. PH2)ANTRB=ANTRB-PH2
C          FELA=ANTRB-TAC
C          IF(FELA .GT. PHI)FELA=PH2-FELA
C          IF(FELA .LT. -PHI)FELA=PH2+FELA
C          VE=(A**2)*((COS(REL1)**2)
C          VZ=(B**2)*((DSIN(REL1)**2)

```

```

TORC5777C
TORC5780C
TORC5790C
TORC5810C
TORC5820C
TORC5830C
TORC5840C
TORC5860C
TORC5870C
TORC5880C
TORC5890C
TORC5910C
TORC5920C
TORC5930C
TORC5940C
TORC5950C
TORC5960C
TORC5970C
TORC5980C
TORC5990C
TORC6000C
TORC6010C
TORC6020C
TORC6030C
TORC6040C
TORC6050C
TORC6060C
TORC6070C
TORC6080C
TORC6090C
TORC6100C
TORC6110C
TORC6120C
TORC6130C
TORC6140C
TORC6150C
TORC6160C
TORC6170C
TORC6180C
TORC6190C
TORC6200C
TORC6210C
TORC6220C
TORC6230C
TORC6240C

```

TORC6255C  
 TORC6260C  
 TORC6270C  
 TORC6280C  
 TORC6290C  
 TORC6300C  
 TORC6310C  
 TORC6320C  
 TORC6330C  
 TORC6340C  
 TORC6350C  
 TORC6360C  
 TORC6370C  
 TORC6380C  
 TORC6390C  
 TORC6400C  
 TORC6410C  
 TORC6420C  
 TORC6430C  
 TORC6440C  
 TORC6450C  
 TORC6460C  
 TORC6470C  
 TORC6480C  
 TORC6490C  
 TORC6500C  
 TORC6510C  
 TORC6520C  
 TORC6530C  
 TORC6540C  
 TORC6550C  
 TORC6560C  
 TORC6570C  
 TORC6580C  
 TORC6590C  
 TORC6600C  
 TORC6610C  
 TORC6620C  
 TORC6630C  
 TORC6640C  
 TORC6650C  
 TORC6660C  
 TORC6670C  
 TORC6680C  
 TORC6690C  
 TORC6700C  
 TORC6710C  
 TORC6720C

```

V=(V1+V2)**2
C COMPUTE SCALING FACTOR DUE TO ASPECT (STEP C11)
L=SCALE(RELE)
F1FACT=L/V
C
C CALCULATE RETURN TIME FOR ECHC (STEP C12)
TIMCL2=2.*TIMDL1
C
C CALCULATE REL BEARING FOR RETURNING ECHO (STEP C13)
TURNST=TRATE*TIMCL2
TXC=TCCLRS+SIGN(TURNST, FN)
TXCC=ABS(MCCURS-TXC)
IF(TXCC.GT. PHI) TXCC=PH2-TXDC
IF(TXCC.LE. ALFA) GC TC 18
ALF=TXCC-ALFA
RELTO=RELO-SIGN((TURNST-ALF), PHI)+SIGN(ALF, FN)
GC TO 19
RELTO=RELO-SIGN(TURNST, FN)
RELCIF=RELC-RELO
RELT1=REL1+RELDIF
RELT2=REL2+RELDIF
IF(RELT1.GT. PHI) RELT1=PH2-RELT1
IF(RELT1.LT. -PHI) RELT1=PH2-RELT1
IF(RELT2.GT. PHI) RELT2=PH2-RELT2
IF(RELT2.LT. -PHI) RELT2=PH2-RELT2
C
C TEST FOR DCFPLER
FRGDEF=50.*2.*(TO*CCS(DC)-1.)/1500.
FFCCIF=50.*2.*(TO*CCS(DC)+1.)/1500.
RELC=RELB
FRCSH=50.*2.*(TO*CCS(DD)+TA*CCS(RELC))/1500.
IF((FRQSF.LT. FRQDIF).AND.(FRCSH.GT. FRGDEF)) GC TC 20
C
C CALCULATE RANGE AND BEARING TO CLOSEST PART OF TARGET (STEP C14)
C(1,1)=DIST
C(1,2)=RELT1+DD
C(2,1)=DIST1
C(2,2)=RELT1+DD
C(3,1)=DIST2
C(3,2)=RELT2+DD
C(4,1)=EB(1,1)
MC=1
IF(CMIN.GT. DB(2,1)) GC TO 10
IF(CMIN.GT. DB(3,1)) GC TC 11
GC TC 12

```

C

C

C

18  
 19

C

C

9

```

10 CMIN=CE(2,1)
11 MC=TC S
12 CMIN=CB(3,1)
    MC=2
    EFEL=CE(MC,2)
    IF(BREL .GT. PHI)BREL=PH2-BREL
    IF(EREL .LT. -PHI)BREL=PH2+BREL
C   CALCULATE RECEIVING GAIN FACTOR (STEP D15)
    REX1=RELT1
    REX2=RELT2
    XC1=XFACT(REX1,ALAM)
    XC2=XFACT(REX2,ALAM)
    XC3=(XC1+XC2+XC3)/3.
C   CALCULATE FRACTION OF POWER IN TC RECIEVER (STEP D16)
    PCBER=CCNST*XX1*XX2*FIFACT/(DIST**4)
C   TEST FOR DETECTION THRESHOLD (STEP D17)
    IF(PCBER .LT. (OWPAX)GC TC 15
C   COMPUTE BEARING RATE (STEP D18)
    ACF=RB+PHI-TAC
    IF(ASP .GT. PHI)ASP=ASP-PH2
    IF(ASP .LT. -PHI)ASF=PH2+ASF
    AF=ASP*RELT C
    TACS=TA*SIN(ABS(ASF))
    TCCS=TO*SIN(ABS(RELT))
    ERATE=(TACS+SIGN(TCCS,AP))/DIST
C   CHECK BEARING RATE AGAINST TURNRATE (STEP D19)
    IF(ERATE .GE. TRATE)GO TO 15
C   CHECK TCRPEDO SPEED ADVANTAGE (STEP D20)
    TALS=TA*CCS(ABS(ASP))
    TCLS=TC*CCS(ABS(RELT))
    IF(AES(ASP) .GT. PHI/2.)TALS=-TALS
    IF(AES(RELT) .GT. PHI/2.)TCLS=-TCLS
    IF((TALS+TCLS) .LE. 0.)GC TC 15
C   FILE=RE-PCCLFS
    IF(RLB .GT. PHI)RLB=RLB-PH2
    IF(RLB .LT. -PHI)RLE=PH2+RLB

```

```

TORC673C
TORC674C
TORC675C
TORC676C
TORC677C
TORC678C
TORC679C
TORC680C
TORC681C
TORC682C
TORC683C
TORC684C
TORC685C
TORC686C
TORC687C
TORC688C
TORC689C
TORC690C
TORC691C
TORC692C
TORC693C
TORC694C
TORC695C
TORC696C
TORC697C
TORC698C
TORC699C
TORC700C
TORC701C
TORC702C
TORC703C
TORC704C
TORC705C
TORC706C
TORC707C
TORC708C
TORC709C
TORC710C
TORC711C
TORC712C
TORC713C
TORC714C
TORC715C
TORC716C
TORC717C
TORC718C
TORC719C
TORC720C

```

TCR0721C  
 TCR0722C  
 TCR0723C  
 TOR0724C  
 TOR0725C  
 TOR0726C  
 TOR0727C  
 TOR0728C  
 TCR0729C  
 TCR0730C  
 TOR0731C  
 TOR0732C  
 TOR0733C  
 TCR0734C  
 TOR0735C  
 TOR0736C  
 TOR0737C  
 TOR0738C  
 TOR0739C  
 TCR0740C  
 TOR0741C  
 TOR0742C  
 TOR0743C  
 TOR0744C  
 TOR0745C  
 TCR0746C  
 TOR0747C  
 TOR0748C  
 TOR0749C  
 TOR0750C  
 TCR0751C  
 TCR0752C  
 TOR0753C  
 TOR0754C  
 TOR0755C  
 TOR0756C  
 TOR0757C  
 TOR0758C  
 TOR0759C  
 TOR0760C  
 TOR0761C  
 TOR0762C  
 TOR0763C  
 TOR0764C  
 TOR0765C  
 TOR0766C  
 TOR0767C  
 TOR0768C

STCRE DETECTION DATA (STEP C21)

JCCNT=JCCNT+1  
 JMAX=MAX(JMAX,JCCNT)  
 ICCNT=JCCNT  
 IF (ICCNT .GE. 5) ICCNT=5

STCRE DATA IN ACCORDANCE WITH NUMBER SUCCESSIVE

DETECTIONS (STEP C22)  
 CC TO (3,1) = DIST  
 IF (FMAX(1,1) .NE. 0.) GO TO 20  
 FMAX(1,1) = C \* (DIST + DC) / RAD  
 IF (FMAX(1,2) .GT. 180.) RMAX(1,2) = RMAX(1,2) - 360.  
 FMAX(1,3) = DMIN  
 FMAX(1,4) = BBREL / RAD  
 FMAX(1,5) = BREL / RAD  
 FMAX(1,6) = RLB / RAD  
 CC TO 20

IF (FMAX(2,1) .NE. 0.) GO TO 20  
 FMAX(2,1) = DIST  
 FMAX(2,2) = (REL TO + DC) / RAD  
 IF (RMAX(2,2) .GT. 180.) RMAX(2,2) = RMAX(2,2) - 360.  
 FMAX(2,3) = DMIN  
 FMAX(2,4) = BBREL / RAD  
 FMAX(2,5) = BREL / RAD  
 FMAX(2,6) = RLB / RAD  
 CC TO 20

IF (FMAX(3,1) .NE. 0.) GO TO 20  
 FMAX(3,1) = C \* JGC TO 20  
 FMAX(3,2) = (REL TO + CC) / RAD  
 IF (RMAX(3,2) .GT. 180.) RMAX(3,2) = RMAX(3,2) - 360.  
 FMAX(3,3) = DMIN  
 FMAX(3,4) = BBREL / RAD  
 FMAX(3,5) = BREL / RAD  
 FMAX(3,6) = RLB / RAD  
 CC TO 20

IF (FMAX(4,1) .NE. 0.) GO TO 20  
 FMAX(4,1) = C \* JGC TO 20  
 FMAX(4,2) = (REL TO + DD) / RAD  
 IF (RMAX(4,2) .GT. 180.) RMAX(4,2) = RMAX(4,2) - 360.  
 FMAX(4,3) = DMIN  
 FMAX(4,4) = BBREL / RAD  
 FMAX(4,5) = BREL / RAD  
 FMAX(4,6) = RLB / RAD  
 CC TO 20

IF (FMAX(5,1) .NE. 0.) GO TO 20

CC

CC

25  
 30

21

22

23

34



```

TCR0817C
TCR08180
TCR0819C
TCR0820C
TCR08210
TCR0822C
TCR0823C
TCR08240
TCR0825C
TCR08260
TCR08270
TCR0828C
TCR0829C
TCR0830C
TCR0831C
TCR0832C
TCR0833C

```

```

RETURN
ENC
C
C
C
C
C
FUNCTIONAL SCALING FACTOR IN THE PROCESS CF
CALCULATE SCALING STRENGTH
COMPUTING TARGET STRENGTH
ECCLELE PRECISION SCALE, RELB, Z, Y
PHI=3.151552654
IF(Y.GT.PHI/2.)Y=PHI-Y
Z=C.251635*(Y**2) - C.18555*Y
Z=Z+0.02665*DSIN(3.*(Y+0.17453)) + C.015*(Y**2)*DSIN(5.*Y/2.)
SCALE=1./Z
RETURN
ENC

```

APPENDIX B

FLOW CHART FOR SIMULATION PROGRAM

A TORPEDO SIMULATION. MAIN PROGRAM. PAGE 1

A TORPEDO SIMULATION. MAIN PROGRAM.

A TORPEDO SIMULATION.

SIMULATING AN ACTIVE HOMING TORPEDO DURING SEARCH.

THE PROGRAM IS RUN IN 0.5 SEC STEPS.

COMMON ISEED2, TTIME, TO, TA, TRATE, RANGE, ALFA, LAMBE, TADEC,  
 BEAB, BAC, TAC, CCCR, DEVSP, ENG, EN, PH2, MCCURS, TCOURS,  
 MXT, MYM, IK, IDTIME, ITIME, XT, YT, XTAR, YTAB, MDIST,  
 TUBETO, INTVAL, PHI, RMAX(5,6), FRANGE, JIST, IPRINT

COMMON/DATA/TA, OPLOB

COMMON/TARGET/TACNG, TAM1, ANGMOD, DA1, COUR, CE(10), SE(15), JRUN,  
 IFLAG, DA2

DIMENSION BM(5,5), VAR(5), DET(150,5), DETB(150,5), STD(5),  
 ASPEC(150,5), DERB(150,5), CLOS(150,5), KON(150,5)

REAL LAMBE, MCOURS, MXT, MYM, MDIST, LAMBDG

INTEGER RUNOUT

SETTING OF CONSTANTS (STEP 1)

CALL OVFLCH

```

-----
PHI  = 3.141592654
PH2  = 2.*PHI
RAD  = PH2/360.
ISEED1 = 262776
ISEED2 = 961655
-----
    
```

CCOREC - MAX ERROR IN TARGET COURSE ESTIMATE

```

-----
CCOREC = 15.
CCOR  = CCOREC*RAD
-----
    
```

CSPEED - ST DEV IN TARGET SPEED ESTIMATE

```

-----
CSPEED = 3.
DEVSP  = CSPEED*0.5
ITIME  = 1
-----
    
```

SET NUMBER OF ITERATIONS

```

-----
IRUN  = 150
-----
    
```

(CONTINUED ON PAGE 2)

SET PRINT OUT MODE

```

      |-----|
      | IPRINT = 1 |
      |-----|
    
```

SET LCEE OFF TORPEDO CENTER BEARING

```

      |-----|
      | CFLOB=0. |
      |-----|
    
```

SET TABLES TO ZERO (STEP 2)

```

      |-----|
      | DO 11 |
      | I=1,5 |
      |-----|
      | DO 12 |
      | J=1,5 |
      |-----|
      | EM(I,J) = 0. |
      |-----|
12  |-----|
11  |-----|
      | DO 13 |
      | J=1,5 |
      |-----|
      | DO 14 |
      | I=1, IEUN |
      |-----|
      | KCN(I,J) = 0 |
      |-----|
14  |-----|
13  |-----|
      | IA2 = 0. |
      |-----|
    
```

(CONTINUED ON PAGE 3)

COMPUTE TARGET ERRORS AND STORE

```

DO
  20
  I=1,10
  CE (I) = - (15. *RAD + CCOR / 10.) + (CCOR
    / 10.) * I * 2.
20 *****CCONTINUE
SR (1) = -1.8737 * DEVSP
SR (2) = -1.2825 * DEVSP
SR (3) = -0.666 * DEVSP
SR (4) = -0.7285 * DEVSP
SR (5) = -0.554 * DEVSP
SR (6) = -0.44 * DEVSP
SR (7) = -0.1675 * DEVSP
SR (8) = 0 * DEVSP
SR (9) = 0 * DEVSP
SR (10) = 0.34 * DEVSP
SR (11) = 0.725 * DEVSP
SR (12) = 0.725 * DEVSP
SR (13) = 0.554 * DEVSP
SR (14) = 0.44 * DEVSP
SR (15) = 0.1675 * DEVSP
  
```

```

100 DO
  900
  JRUN=1, IEJN
  SET RUN COUNTERS (STEP 3)
  IFLAG=1; TOC LOW TORPEDO SPEED
  IFLAG=0
  ICCNT=0
  JCNT=0
  IITIME=0
  IL = C
  IK = C
  CIST = C.
  MET = C.
  MKM = C.
  SUNOUT = 0
  
```

(CONTINUED ON PAGE 4)



















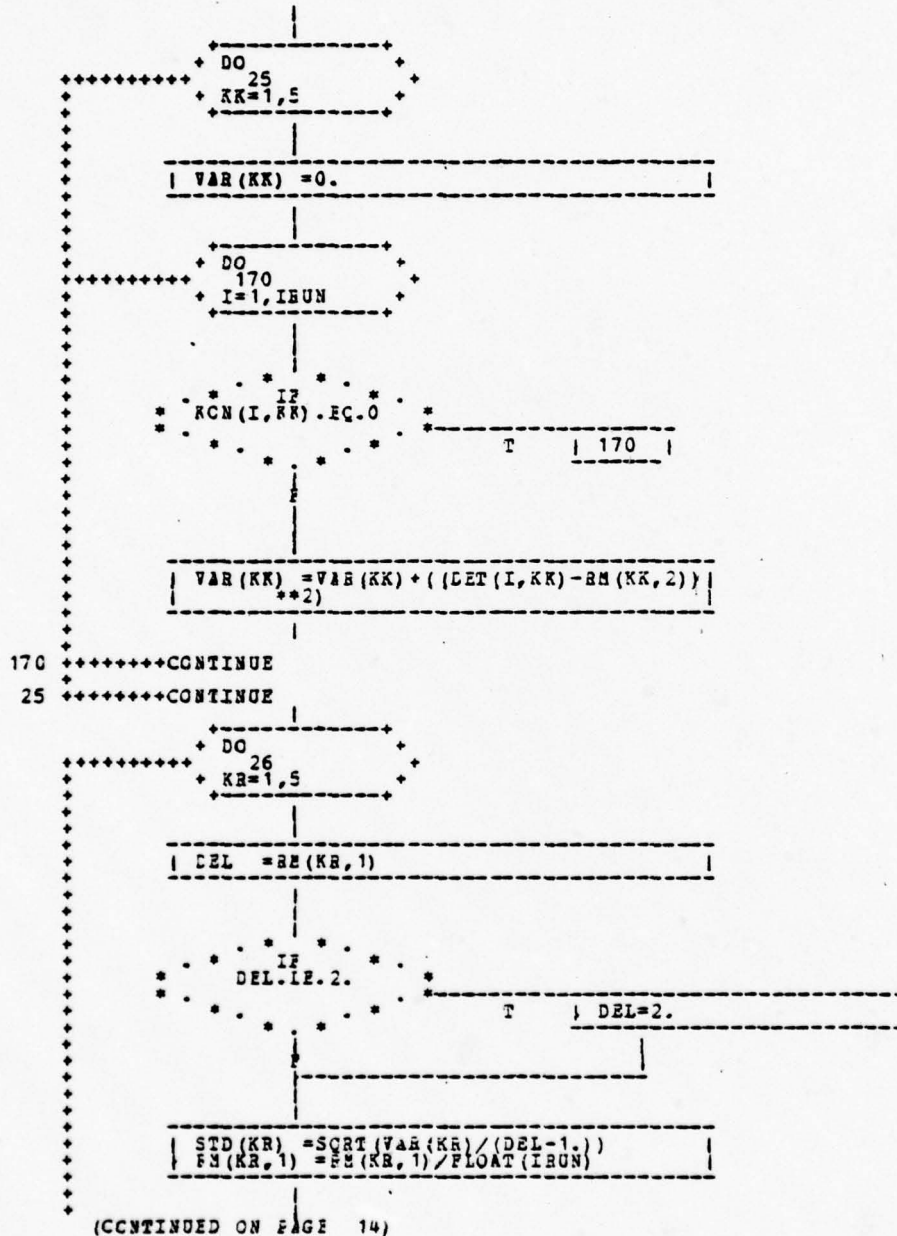

(CONTINUED ON PAGE 14)

```

+
+
+
+*****CCFINUE
    
```

PRINT SUMMARY (STEP 13)

```

***WRITE (6, 157) IRUN
197   FCORMAT (1X, //, 6X, 'SUMMARY OF RESULT AFTER', 3X, I4, 2X, 'RUNS')
***WRITE (6, 199) ((RM(I, J), J=1, 2), STD(I), (RM(I, J), J=3, 5), I=1, 5)
199   FCORMAT (10X, 'FEASIBILITY OF DETECTION', 8X
    'AVERAGE', 6X, 'STD DEVIATION', 7X, 'AVERAGE',
    7X, 'AVERAGE', //, 41X
    'DET RANGE', 6X, 'DET RANGE', 7X, 'TARGET ASPECT', 4X, 'DET BEARING',
    3X, 'REL BEARING' //,
    1X, 'ONE SUCCESSIVE DETECTION', 5X, F6.4, 5 (6X, F9.4) //,
    1X, 'TWO SUCCESSIVE DETECTIONS', 4X, F6.4, 5 (6X, F9.4) //,
    1X, 'THREE SUCCESSIVE DETECTIONS', 2X, F6.4, 5 (6X, F9.4) //,
    1X, 'FOUR SUCCESSIVE DETECTIONS', 3X, F6.4, 5 (6X, F9.4) //,
    1X, 'FIVE SUCCESSIVE DETECTIONS', 3X, F6.4, 5 (6X, F9.4) //)
220   FCORMAT (1X, 'NO DETECTION MADE DURING THIS RUN')
-----
| LA2 =LA2/FLCAT(IRUN) |
-----
|
***WRITE (6, 190) LA2
190   FCORMAT (1X, //, 1X, 'AVERAGE DEFLECTION ANGLE :', 5X, F8.4, //)
***WRITE (6, 234)
234   FCORMAT (1X, //, 1X, 'DISTRIBUTION OF RUN RESULT - CENTER OF TARGET', //,
    6X, 'ONE SUCCESSIVE DETECTION', 10X, 'TWO SUCCESSIVE DETECTIONS', //,
    8X, 'THREE SUCCESSIVE DETECTIONS', //,
    2X, 'BEAR', 2X, 'RANGE', 2X, 'ASPECT', 2X, 'BEAR', 2X, 'RANGE',
    'RANGE ASPECT BEAR CLCS', 5X, 'BEAR', 2X,
    'RANGE ASPECT BEAR CLCS')
***WRITE (6, 236) ((DET(I, 1), DET(I, 1), ASPEC(I, 1), CLOS(I, 1),
    DET(I, 2), DET(I, 2), ASPEC(I, 2), CLOS(I, 2), DET(I, 3),
    DET(I, 3), ASPEC(I, 3), CLOS(I, 3)), I=1, IRUN)
236   FCORMAT (3 (1X, F6.1, 1X, F6.1, 1X, F6.1, 2X, F6.1, 5X))
599   STOP
    
```

END

A TORPEDO SIMULATION. SUBROUTINE PARMET.

SUBROUTINE PARMET

READING IN DATA AND PARAMETERS

COMMON ISEED2, TTIME, TO, TA, TRATE, RANGE, ALFA, LAMBE, TADEC,  
BEAB, RAL, TAC, CCOR, DEVSP, BNG, EN, PH2, MCCURS, TCOURS,  
MXT, MXM, IK, IDTIME, ITIME, XT, YT, XTAR, YTAR, TDIST,  
MDIST, TURNTO, INTVAL, PHI, RMAX(5,6), TRANGE, DIST, IPHINT  
REAL LAMED, MCCURS, MXT, MXM, HDIST, LAMBDG  
INTEGER BUNCUT

TEDEC - TECHNICAL DETECTION RANGE (STEP A1)

LEVEL OF VARIATION: 375-750-1125-1500 METERS

TADEC - TACTICAL DETECTION RANGE

| TEDEC=750.  
| TADEC=TEDEC |

TTIME - TRANSMISSION INTERVAL

| TTIME=2.\*TEDEC/1500. |

TCKN - TORP SPEED IN KNOTS, TO - TORP SPEED IN M/SEC (STEP A2)

LEVEL OF VARIATION: 24-32-40 KNOTS

| TCKN =40.  
| TO =TCKN/2 |

TAKN - TARGET SPEED IN KNOTS, TA - TARGET SPEED IN M/SEC (STEP A3)

LEVEL OF VARIATION: 12-18-24-30 KNOTS

| TAKN =18.  
| TA =TAKN/2 |

(CONTINUED ON PAGE 2)

TACG - TARGET COURSE IN DEGREE (STEP A4)

| TACG =270  
| TAC =TACG\*RAD  
|

ALFAG - SWEEP ANGLE IN DEGREE, ALFA - SWEEP ANGLE IN RADIANS

(STEP A5)

LEVEL OF VARIATION: 20-30-40 DEGREES

| ALFAG=30.  
| ALFA =ALFAG\*RAD  
|

LAMBDG - LOBE WIDTE EACH SIDE OF TORP HEADING (STEP A6)

LEVEL OF VARIATION: 10-20-30 DEGREES

| LAMBDG =20.  
| LAMED=LAMBDG\*RAD  
|

BELEBG - RELATIVE BEARING FROM TARGET TO TORP IN DEGREE (STEP A7)

LEVEL OF VARIATION: 0-30-60-90-120-180 DEGREES

| BELEBG =-60.  
| BEAR =BELEBG\*RAD  
|

RANGE - DISTANCE BETWEEN TARGET AND TORP (STEP A8)

LEVEL OF VARIATION: 1500-3000-5000-7000 METERS

| RANGE=3000.  
|

(CONTINUED ON PAGE 3)



```
112  ***WRITE (6, 112) RANGE, BELBERG, TACG, TAKN, TEDEC, TOKN, ALFAG,  
      LABEEDG, TRATEG, SRNG, CRATIO  
      FORMAT (1X, F6.0, 2X, F6.1, 3X, F5.1, 3X, F4.1, 6X, F6.1, 3X, F5.1, 3X,  
             F4.1, 3X, F4.1, 2X, F4.1, 2X, F6.1, 3X, F5.3)
```

```
1 95 1
```

```
90  ***WRITE (6, 100)  
100  FCBMAT (1X, 'TACTICAL SITUATION WHEN FIRING', /, 1X,  
          'FIRING RANGE', 3X, 'ATTACK ANGLE', 3X,  
          'TARGET CCOURSE', 2X, 'TARGET SPEED')  
102  ***WRITE (6, 102) RANGE, BELBERG, TACG, TAKN  
      FCBMAT (1X, 4 (2X, F6.1, 7X), /)  
104  ***WRITE (6, 104)  
      FCBMAT (1X, 'TORPEDO PARAMETERS', /, 1X,  
          'TECH. DET. RANGE', 2X, 'TRANS. INT. VAL', 2X, 'TORP SPEED', 3X,  
          'SWEEP ANGLE')  
106  ***WRITE (6, 106) TEDEC, TTIME, TOKN, ALFAG  
      FCBMAT (1X, 2 (2X, F7.2, 7X), 2 (F6.1, 7X), /)  
108  ***WRITE (6, 108) LAMBDG, TRATEG  
      FORMAT (1X, 'LOBE WIDTH', 6X, 'TURN RATE', /,  
             3X, F6.1, 10X, F6.1)  
109  ***WRITE (6, 109) SRNG, CRATIO  
      FCBMAT (1X, 'THEORETICAL WIDTH OF TACTICAL SWEEP-LANE', F9.1,  
             /, 1X, 'THEORETICAL COVERAGE RATIO', F9.4)  
95  RETURN
```

END

A TORPEDO SIMULATION. SUBROUTINE FIRING.

SUBROUTINE FIRING

CALCULATE THE TOEP DEFLECTION ANGLE, MAIN COURSE, FIRING COURSE  
 BASED ON ESTIMATE OF TARGET DATA (UNCERTAINTY)

DIMENSION U(2)

COMMON ISEED2, TTIME, TO, TA, TRATE, RANGE, ALFA, LAMB, TADCC,  
 BEAR, RAL, TAC, CCOBS, DEVS, ENG, EN, PH2, MCCURS, TCOURS,  
 MIT, MXM, IK, IDTIME, ITIME, XT, YT, XTAR, YTAR, MDIST,  
 MDIST, TUBNTC, INTVAL, PHI, SMAX(5,6), TRANGE, DIST, IPBINT

COMMON/DATA/IA, OFLOS

COMMON/TARGET/TACMG, TAN1, RNMOD, DA1, COUR, CE(10), SE(15), JRUN,  
 IFLAG, DA2

REAL LAMB, MCCURS, MIT, MXM, MDIST, LAMBDG

INTEGER RUNCUT

```

|-----|
| EN   = -1 |
| ISEED = 1. |
| KSPEED = MOD((JRUN-1), 15) + 1 |
| KCOURS = IFIX((JRUN-1)/15.) + 1 |
|-----|
    
```

CALL GGUE (ISEED2, 2, U)

CALCULATE ESTIMATE OF TARGET COURSE (STEP B1)

19

| TACM = TAC + CE(KCOURS) |

20

| DIFCO = TACM - TAC |

(CONTINUED ON PAGE 2)





CALCULATE TORPEDO PRESENT FIRING COURSE (STEP B5)

```
| DIFALF = (U(1)*2.*ALFA) - ALFA |  
| TCOURS = ACCOURS + DIFALF |
```

```
      * * * IF * * *  
* . . . TCOURS.GT.PH2 . . . *  
* . . . * * * * * T | TCOURS=TCOURS-PH2
```

```
      * * * IF * * *  
* . . . TCOURS.LT.0 . . . *  
* . . . * * * * * T | TCOURS=PH2+TCOURS
```

```
      * * * IF * * *  
* . . . DIFALF.GE.0 . . . *  
* . . . * * * * * T | FN=-PN
```

CALCULATE ESTIMATE OF TARGET RANGE (STEP B6)

```
      * * * IF * * *  
* . . . U(2).GE.0.5 . . . *  
* . . . * * * * * T | FP=-PP
```

```
| RANGDIF = (1.-U(2)) * RANGE * 0.15 |
```

(CONTINUED ON PAGE 5)



A TORPEDO SIMULATION. SUBROUTINE POSIS.

SUBROUTINE POSIS  
 IS CALCULATING NEW POSITIONS OF TARGET AND TORPEDO IN  
 EACH TIME STEP

COMMON ISEED, TTIME, TO, TA, TRATE, RANGE, ALFA, LAMB, TADEC,  
 BEAR, RAL, TAC, CCCR, DEVSP, ENG, FN, PH2, NCOURS, TCOURS,  
 MYT, MYM, IR, IDTIME, ITIME, YI, YI, XTAR, YIAR, TDIST,  
 MDIST, TURNIC, INTVAL, PHI, RMAX(5,6), TRANGE, DIST, IPBINT  
 REAL LAMB, NCOURS, MYT, MYM, MDIST, LAMB  
 INTEGER BUNCUT

TIME CCUNT (STEP C1)

```

|-----|
| IK      =IK+1 |
| ITIME=ITIME+IDTIME |
|-----|
    
```

CALCULATE TOTAL TCRP RUN AND TARGET RUN (STEP C2)

```

|-----|
| MYT     =MYT+TDIST |
| MYM     =MYM+MDIST |
|-----|
    
```

CALCULATE NEW POSITIONS (STEP C3)

```

|-----|
| YI      =YI+SIN(TCOURS)*TDIST |
| YIAR    =YI+CCS(TCOURS)*TDIST |
| YIAR    =YIAR+SIN(TAC)*MDIST  |
| YIAR    =YIAR+CCS(TAC)*MDIST  |
|-----|
    
```

CALCULATE NEW TOSF COURSE (STEP C4)

```

|-----|
| IXCOUR  =TCOURS+SIGN(TURNIC, FN) |
| IXCDIF  =ABS(NCOURS-IXCOUR) |
|-----|
    
```

(CONTINUED ON PAGE 2)









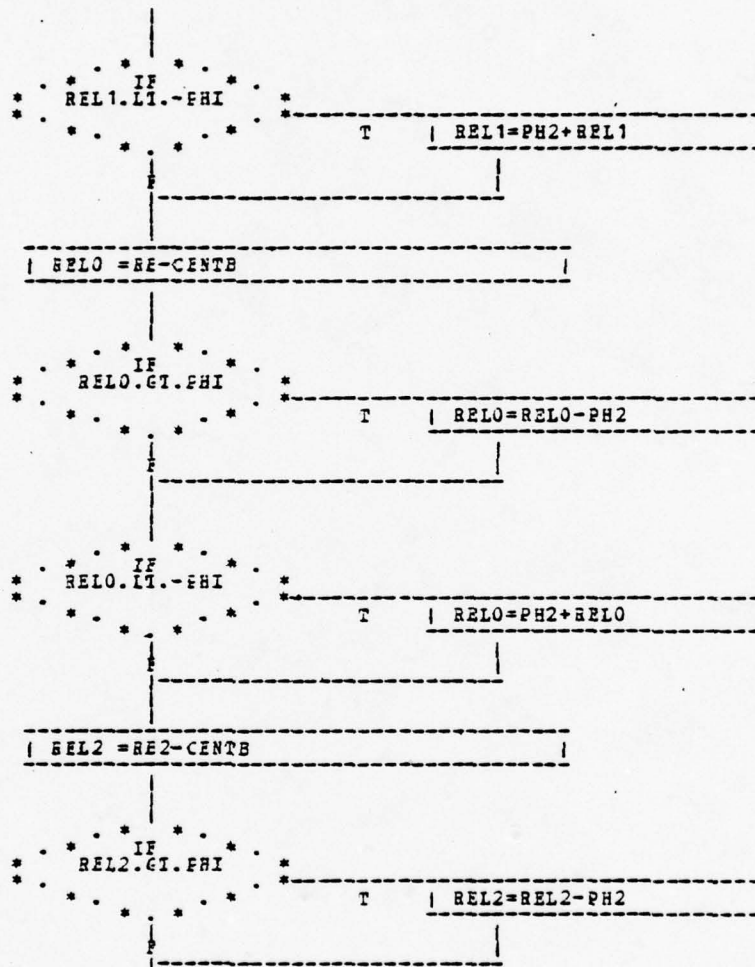

(CONTINUED ON PAGE 5)





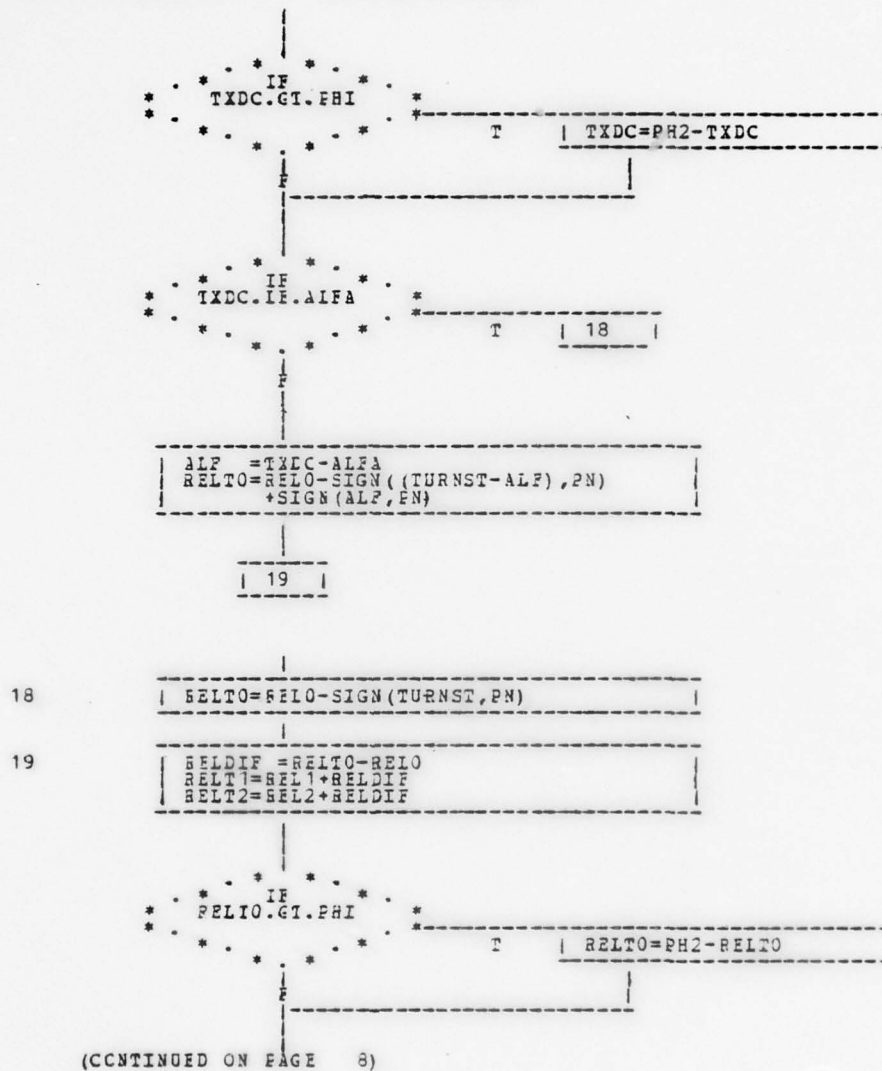

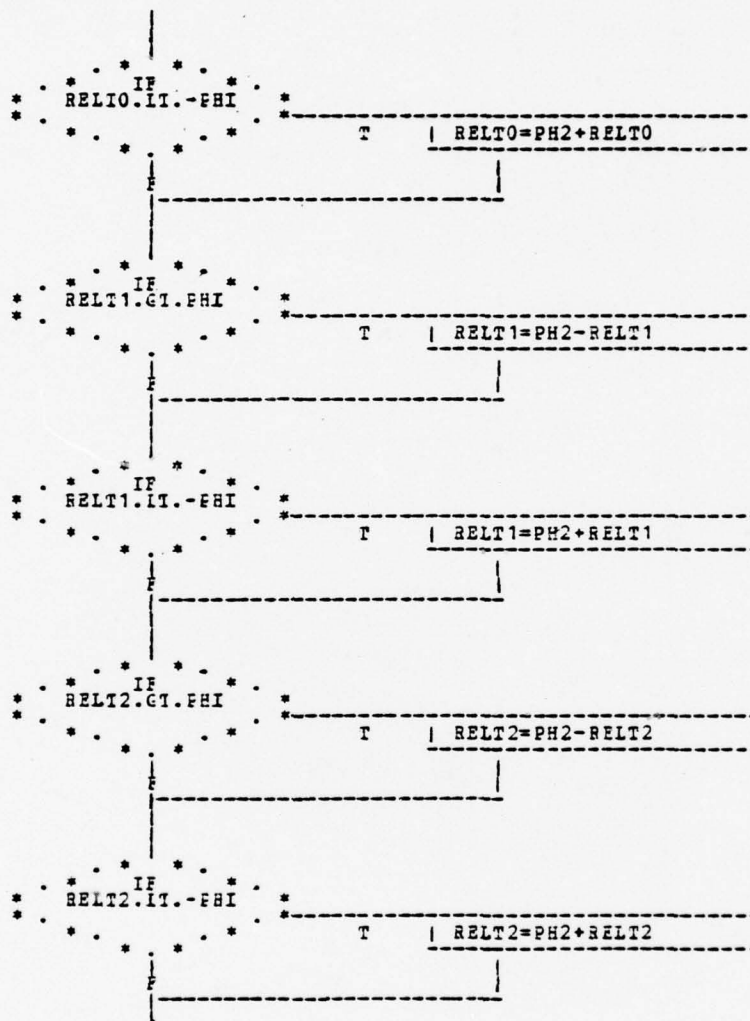

(CONTINUED ON PAGE 9)



|  
| 12 |  
|

10 |-----|  
| CMIN = CE (2,1) |  
MD = 2
9

11 |-----|  
| CMIN = CE (3,1) |  
MD = 3
12
-----

```

      * * * * *
      *   IF   * * * * *
      * BREL.GT.PHI * * * * *
      * * * * *
      * * * * * T | BREL=PH2-BREL
      * * * * *
      * * * * *
      *   IF   * * * * *
      * BREL.LT.-PHI * * * * *
      * * * * *
      * * * * * T | BREL=PH2+BREL
      * * * * *
    
```

CALCULATE RECEIVING GAIN FACTOR (STEP D15)

|-----|  
| RBX1 = RELT1 |  
| RBX2 = RELTC |  
| RBX2 = RELT2 |  
| XO1 = XFACT (RBX1,ALAM) |  
| XO2 = XFACT (RBX2,ALAM) |  
| XO3 = XFACT (RBX2,ALAM) |  
XX2 = (XO1+XO2+XO3)/3.

(CONTINUED ON PAGE 11)

CALCULATE FRACTION OF POWER IN TO RECIEVER (STEP D16)

POWER=CCNST\*\*11\*YX2\*PIFACT/(DIST\*\*4)

TEST FOR DETECTION THRESHOLD (STEP D17)

IF POWER.LT.PCRMAX  
T | 15 |

COMPUTE BEARING RATE (STEP D18)

ASP =BE+PHI-TAC

IF ASP.GT.PHI  
T | ASP=ASP-PH2

IF ASP.LT.-PHI  
T | ASP=PH2+ASP

AP =ASP\*BEI10

(CONTINUED ON PAGE 12)



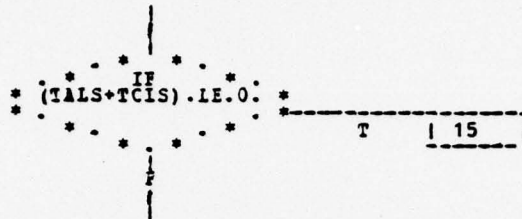

| RLB =RE-MCCORS |

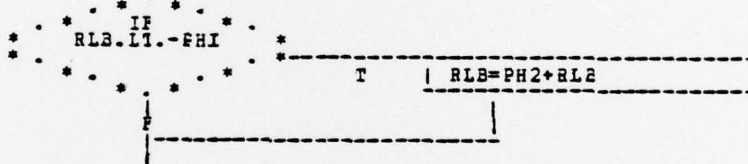
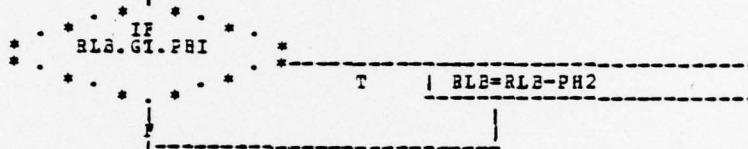

STORE DETECTION DATA (STEP D21)

| JCONT=JCONT+1  
JMAX =MAXO(JMAX,JCONT)  
ICONT=JCONT |

(CONTINUED ON PAGE 14)









A TORPEDO SIMULATION. FUNCTION BEARIN.

PAGE 1

A TORPEDO SIMULATION. FUNCTION BEARIN.

FUNCTION BEARIN(A,B,C,D)  
TO CALCULATE BEARING FROM TORPEDO TO TARGET

```
-----  
DIFX = A-C  
DIFY = B-D  
RH2 = 2.*3.141592654  
RAD = RH2/360.  
-----
```

```
      * * * * *  
      * * IF * * * * *  
      * * DIFX.NE.0. * * * * *  
      * * * * *  
      * * * * * T | 16 |  
      * * * * *
```

```
-----  
| BE = 90.*RAD  
-----
```

```
      * * * * *  
      * * IF * * * * *  
      * * DIFX.LT.0. * * * * *  
      * * * * *  
      * * * * * T | BB=RB+(180.*RAD)  
      * * * * *
```

```
-----  
| 17 |  
-----
```

16

```
-----  
| BB = ATAN2(DIFX,DIFY)  
-----
```

(CONTINUED ON PAGE 2)





A TORPEDO SIMULATION. FUNCTION SCALE.

PAGE 1

A TORPEDO SIMULATION. FUNCTION SCALE.

FUNCTION SCALE(Y)  
CALCULATE SCALING FACTOR IN THE PROCESS OF  
COMPUTING TARGET STRENGTH

DOUBLE PRECISION SCALE, RELB, Z, Y

PHI = 3.151592654

IF  
Y.GT.PHI/2. T | Y=PHI-Y

Z = 0.251635\*(Y\*\*2)-0.18555\*Y  
Z = Z+0.0365\*D SIN(3.\*(Y+0.17453))  
+0.015\*(Y\*\*2)\*D SIN(9.\*Y/2.)  
SCALE=1./Z

RETURN

END

APPENDIX C

DETAILED RUN PRINTOUT

TACTICAL SITUATION WHEN FIRING  
 FIRING RANGE 3000.0 ATTACK ANGLE -60.0 TARGET COURSE 270.0 TARGET SPEED 13.0

TORPEDO PARAMETERS  
 TECH. DET. RANGE 750.0 TRANS. INT. VAL 1.00 TORP SPEED 40.0 SNEER ANGLE 30.0

LOPE WIDTH 20.0 TURN RATE 0.0  
 THEORETICAL WIDTH OF TACTICAL SNEER-LINE 1140.1  
 THEORETICAL COVERAGE RATIO 0.6500

SOUND MAIN LOPE OFF-SET FROM CENTER BEADING 0.0 TIMES REFLECTION ANGLE

RUN NUMBER : 1  
 EST OF TARGET DATA FOR FIRING  
 COURSE SPEED RANGE  
 256.5 12.4 3345.1  
 TORP REFLECTION ANGLE IS -12.07  
 TORPEDO MAIN COURSE 17.03  
 RUN STOPPED AFTER 136 SECONDS

RUN DATA AS FOLLOWS AT END OF RUN  
 TOTAL TORP RUN 3730.0  
 DIST TO TARGET 313.0  
 TORP X-COORD 14274.5 TORP Y-COORD 15000.0  
 TARGET X-COORD 13771.5 TARGET Y-COORD 15000.0  
 TORP MAIN COURSE 17.027 TORP COURSE 357.623  
 NO DETECTION MADE DURING THIS RUN

RUN NUMBER : 2  
 EST OF TARGET DATA FOR FIRING  
 COURSE SPEED RANGE  
 256.5 14.2 2792.4  
 TORP REFLECTION ANGLE IS -14.37  
 TORPEDO MAIN COURSE 15.13  
 RUN STOPPED AFTER 147 SECONDS

RUN DATA AS FOLLOWS AT END OF RUN  
 TOTAL TORP RUN 3240.0  
 DIST TO TARGET 321.1  
 TORP X-COORD 14200.7 TORP Y-COORD 15000.0  
 TARGET X-COORD 13677.0 TARGET Y-COORD 15000.0  
 TORP MAIN COURSE 15.123 TORP COURSE 11.500

MAXIMUM DETECTION RANGES AND BEADINGS				MAX DET		DET BEADING		TARGET
SUCCESSIVE	MAX	DET	DET BEADING	RANGE	CLOSEST	CLOSEST	ASPECT	
DET	NO.	RANGE - CENTER	CENTER					
1		302.5	5.17	300.0		10.20	107.50	
2		345.0	-1.40	330.0		3.20	110.00	
3		0.0	0.0	0.0		0.0	0.0	
4		0.0	0.0	0.0		0.0	0.0	
5		0.0	0.0	0.0		0.0	0.0	

## LIST OF REFERENCES

1. Barton, D.K., Radar system analysis, Prentice-Hall, 1964,
2. Camp, L., Underwater Acoustics, Wiley-Interscience, 1970,
3. Cox, A.C., Sonar And Underwater Sound, Lexington Books, 1974,
4. Edit. Crispin jr, J.W. and Siegel, K.M., Methods of Radar Cross-Section Analysis, Academic Press, 1968,
5. Edit. Stephens, R.W.B., Underwater Acoustic, Wiley-Interscience, 1970,
6. Urick, R.J., Principle Of Underwater Sound, McGraw-Hill, 1975,
7. Hutchings, P.J., The Mk. 24 Tigerfish Torpedo, International Defence Review, Vol 10, pg. 294-295, no 2, 1977,
8. International Defence Review, Some Modern Torpedo Development, Vol 9, pg. 91-95, no 1, 1976,
9. Ramsauer, U., Torpedo Development in Germany, International Defence Review, Vol 9, pg. 96-100, no 1, 1976,
10. Missile and Rockets, Torpedo Terms and Terminology, Vol 2, pg. 127-132, May 1957,
11. Ruhe, W.J., Capt., The Nuclear Submarine: Riding High, U S Naval Institute Proceedings, Vol 101, no 2, pg. 55-62, February 1975,

INITIAL DISTRIBUTION LIST

	No.	Copies
1. Defence Documentation Center Cameron Station Alexandria, Virginia 22314		2
2. Royal Norwegian Naval Headquarter Oslo Mil Oslo 1, Norway		2
3. Library, Code 0212 Naval Postgraduate School Monterey, California 93940		2
4. Department Chairman Department of Operations Research Naval Postgraduate School Monterey, California 93940		1
5. Professor Alan R. Washburn Department of Operations Research Naval Postgraduate School Monterey, California 93940		1
6. Professor Harold A. Titus Department of Electrical Engineering Naval Postgraduate School Monterey, California 93940		1
7. Lt.Cdr. Anders Mjelde Oslo Mil Oslo 1, Norway		1