

AD-A047 268

COAST GUARD RESEARCH AND DEVELOPMENT CENTER GROTON CONN F/G 13/12  
AUTOMATED DECK FOAM FIRE EXTINGUISHING SYSTEMS FOR TANKERS.(U)  
APR 77 D E BEENE, R C RICHARDS  
CGR/DC-7/77

USCG-D-51-77

NL

UNCLASSIFIED

JOE /  
AD  
A047268



END  
DATE  
FILMED  
1 - 78  
DDC

12  
B.S.

REPORT NO. CG-D-51-77

Task No. 3308.5

# AUTOMATED DECK FOAM FIRE EXTINGUISHING SYSTEMS FOR TANKERS

AD A 0 4 7 2 6 8

David E. Beene, Jr., and Robert C. Richards  
U. S. Coast Guard Research and Development Center  
Avery Point, Groton, Connecticut 06340



April 1977

Final Report

DDC  
REFILED  
DEC 6 1977  
RECEIVED  
B

Document is available to the U. S. public through the  
National Technical Information Service,  
Springfield, Virginia 22161

AD No. \_\_\_\_\_  
DDC FILE COPY

PREPARED FOR  
**U.S. DEPARTMENT OF TRANSPORTATION**  
**UNITED STATES COAST GUARD**  
**OFFICE OF RESEARCH AND DEVELOPMENT**  
**WASHINGTON, D.C. 20590**

NOTICE

This document is disseminated under the sponsorship of the Department of Transportation in the interest of information exchange. The United States Government assumes no liability for its contents or use thereof.

The United States Government does not endorse products or manufacturers. Trade or manufacturers' names appear herein solely because they are considered essential to the object of this report.

The contents of this report reflect the views of the Coast Guard Research and Development Center, which is responsible for the facts and accuracy of data presented. This report does not constitute a standard, specification or regulation.

*D. L. Birkimer*

DONALD L. BIRKIMER, Ph.D., P.E.  
Technical Director

U.S. Coast Guard Research and Development Center  
Avery Point, Groton, Connecticut 06340

1. Report No. <b>19</b> <b>18</b> USCG-D-51-77 ✓	2. Government Accession No.	3. Recipient's Catalog No.	
<b>6</b> AUTOMATED DECK FOAM FIRE EXTINGUISHING SYSTEMS FOR TANKERS,		<b>11</b> 5. Report Date Apr 77	<b>12</b> 72 p.
<b>10</b> 7. Author(s) DAVID E. BEENE, JR. ROBERT C. / RICHARDS Performing Organization Name and Address U. S. Coast Guard Research and Development Center ✓ Avery Point Groton, CT 06340		6. Performing Organization Code	8. Performing Organization Report No. <b>14</b> CGRDC-7/77 ✓
12. Sponsoring Agency Name and Address Department of Transportation U. S. Coast Guard Office of Research and Development Washington, DC 20590		10. Work Unit No. (TRAIS) 3308.5	11. Contract or Grant No.
15. Supplementary Notes Performed at the U. S. Coast Guard Fire and Safety Test Facility under the technical control of the U. S. Coast Guard Research and Development Center, Avery Point, Groton, Connecticut.		13. Type of Report and Period Covered <b>9</b> FINAL REPORT,	
16. Abstract Full-scale tests were conducted on the tank vessel A.E. WATTS at the U.S. Coast Guard Fire and Safety Test Facility, Mobile, Alabama, to investigate alternatives to the manually operated monitor in a deck foam fire extinguishing system. The alternatives included oscillating, automatic, and remotely controlled monitors. The test series investigated the effectiveness and efficiency of these alternatives through maneuverability tests, stability tests, foam placement tests, and full-scale fire tests.  Alternative monitors were compared to a U.S. Coast Guard-approved manual monitor utilizing Coast Guard-approved three percent protein foam as the extinguishing agent. The automated monitors proved effective in controlling and extinguishing the deck fires at slightly longer times than the manual monitor. However, their effectiveness was increased by their ability to function under fire conditions which rendered the manual monitor impossible to approach and operate. The principal problems of the automated monitors were their reliability and durability over short periods of testing. Fail-safe manual override controls for each monitor would partially make up for these problems.			
17. Key Words automated deck foam systems, automated monitors, deck foam fire extinguishing systems, monitors, remote controlled monitors		18. Distribution Statement Document is available to the U.S. public through the National Technical Information Service, Springfield, Virginia 22161	
19. Security Classif. (of this report) UNCLASSIFIED	20. Security Classif. (of this page) UNCLASSIFIED	21. No. of Pages 64	22. Price

i — 408730

*[Handwritten signature]*

## METRIC CONVERSION FACTORS

Approximate Conversions to Metric Measures		Approximate Conversions from Metric Measures	
Symbol	When You Know	Multiply by	To Find
<b>LENGTH</b>			
in	inches	0.0254	meters
ft	feet	0.3048	meters
yd	yards	0.9144	meters
mi	miles	1.6093	kilometers
<b>AREA</b>			
in <sup>2</sup>	square inches	6.4516	square centimeters
ft <sup>2</sup>	square feet	0.0929	square meters
yd <sup>2</sup>	square yards	0.8361	square meters
mi <sup>2</sup>	square miles	2.5900	square kilometers
	acres	0.4047	hectares
<b>MASS (weight)</b>			
oz	ounces	28.3495	grams
lb	pounds	0.4536	kilograms
	short tons (2000 lb)	0.9072	tonnes
<b>VOLUME</b>			
tsp	teaspoons	5	milliliters
Tbsp	tablespoons	15	milliliters
fl oz	fluid ounces	30	milliliters
c	cups	0.24	liters
pt	pints	0.47	liters
qt	quarts	0.95	liters
gal	gallons	3.8	liters
ft <sup>3</sup>	cubic feet	0.03	cubic meters
yd <sup>3</sup>	cubic yards	0.76	cubic meters
<b>TEMPERATURE (exact)</b>			
°F	Fahrenheit temperature	5/9 (after subtracting 32)	Celsius temperature
°C	Celsius temperature	9/5 (then add 32)	Fahrenheit temperature

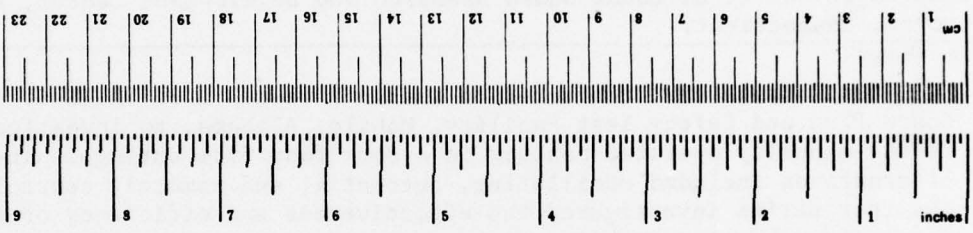

\*1 in = 2.54 (exactly). For other exact conversions and more detailed tables, see NBS Misc. Publ. 286, Units of Weights and Measures, Price \$2.25, SD Catalog No. C1310-286.

ACKNOWLEDGMENTS

The U. S. Coast Guard appreciates the assistance of Feecon, Inc.; Rockwood Systems Corporation; Stang Hydronics, Inc.; Allison Control, Inc.; and National Foams Systems, Inc., in providing materials, equipment and their willing cooperation which led to the successful accomplishment of this test program.

ACCESSION for	
NTIS	White Section <input checked="" type="checkbox"/>
BDC	Buff Section <input type="checkbox"/>
UNANNOUNCED	<input type="checkbox"/>
JUSTIFICATION _____	
BY _____	
DISTRIBUTION/AVAILABILITY CODES	
Dist.	to AIL. and/or SPECIAL
A	

## TABLE OF CONTENTS

	<u>Page</u>
1.0 INTRODUCTION	1
1.1 Purpose	1
1.2 Background	1
1.3 Coast Guard Rules and Regulations	5
1.4 Limitations	5
2.0 TEST PROCEDURES	5
2.1 Experimental Setup	5
2.2 Foam Quality	12
2.3 Foam Depth Test	12
2.4 Maneuverability Test	12
2.5 Fire Tests	16
2.6 Time Studies	16
2.7 Operational Ease and Versatility	19
2.8 Equipment Design	19
3.0 TEST RESULTS AND EVALUATION OF MONITORS	19
3.1 Foam Quality and Patterns	19
3.2 Comparative Foam Depths	21
3.3 Comparative Maneuverability Times	25
3.4 Comparative Control and Extinguishment Times	27
3.5 Operational Time Studies	32
3.6 Operational Design Factors	32
3.6.1 Manual Monitor	33
3.6.2 Oscillating Monitor	33
3.6.3 Servo-Controlled Monitor	37
3.6.4 Remote Controlled Monitors	39
3.6.4.1 Electric, Pushbutton	39
3.6.4.2 Hydraulic, Three Lever	39
3.6.4.3 Hydraulic, Joystick	43
3.6.5 Programmed Automatic Monitor	45
4.0 CONCLUSIONS AND OBSERVATIONS	47
APPENDIX A - FOAM QUALITY TESTS	A-1

## LIST OF ILLUSTRATIONS

<u>Figure</u>		<u>Page</u>
1	FIRE CONDITIONS	2
2	SCHEMATIC OF TANK VESSEL A.E. WATTS	7

<u>Figure</u>		<u>Page</u>
3	TEST PENS AND MONITOR LOCATION	8
4	HEAT SHIELD FOR MONITOR OPERATOR	9
5	PROPORTIONING SYSTEM	10
6	MONITOR INSTRUMENTATION	11
7	GRID PATTERN LAYOUT	13
8	FOAM DEPTH MEASUREMENT POINTS	14
9	MANEUVERABILITY TEST PATTERN	14
10	MANEUVERABILITY TEST IN PROGRESS	15
11	ONE-MINUTE FULL INVOLVEMENT PREBURN OF FIRE	18
12	GRID PATTERNS FOR TESTED MONITORS	23
13	APPLICATION RATES VERSUS CONTROL/EXTINGUISHMENT TIMES	29
14	PROPORTIONING RATES VERSUS CONTROL TIMES	30
15	COAST GUARD-APPROVED MANUAL MONITOR	34
16	OSCILLATING MONITOR	35
17	OSCILLATING MONITOR INTERNAL CONTROLS	36
18	SERVO-CONTROLLED MONITOR	38
19	REMOTE CONTROLLED (ELECTRIC, PUSHBUTTON) MONITOR	40
20	REMOTE CONTROLLED (HYDRAULIC, THREE LEVER) MONITOR	41
21	REMOTE CONTROLLED (HYDRAULIC, JOYSTICK) MONITOR	44
22	PROGRAMMED AUTOMATIC MONITOR	46
23	PAM, ULTRAVIOLET DETECTOR AND OSCILLATING COVERAGE	48

#### LIST OF TABLES

<u>Table</u>		<u>Page</u>
1	TESTED MONITOR EQUIPMENT AND MANUFACTURERS	3
2	OPERATIONAL CONTROL MODES USED DURING TESTING	17
3	FOAM QUALITY RESULTS	20
4	MONITOR CONTROL MODES RANKED BY INCREASING FOAM WASTAGE	22
5	MANEUVERABILITY TIMES	26
6	CONTROL AND EXTINGUISHMENT TIMES	28
7	OPERATIONAL TIMES FOR A MONITOR OPERATOR	31
8	TIMES REQUIRED TO DON PROTECTIVE GEAR	31

## 1.0 INTRODUCTION

This test series was undertaken to investigate alternatives to manually operated monitors in a deck foam fire extinguishing system. The alternatives included oscillating, automatic and remotely controlled monitors which will be referred to collectively as automated monitors. The series investigated the effectiveness of the different monitors then compared the results on a limited number of full-scale test fires. The automated monitors' performance was compared to a Coast Guard-approved manual monitor (Table 1). Three percent protein foam already approved by Coast Guard regulations was used for the tests. The data collected could be used to develop performance criteria for Coast Guard approval of alternate monitor systems.

### 1.1 Purposes

The primary purposes of this test series were to:

- (1) Determine the relative effectiveness of manual versus automated monitors.
- (2) Determine the effectiveness of automated monitors for directing foam placement without waste.
- (3) Compare fire control and total extinguishment times as a function of a shipboard design application rate.
- (4) Conduct a time/motion study for the physical operation of the monitors and the use of protective clothing.
- (5) Determine serviceability, reliability, and durability of the monitors by analysis of monitor design, manufacturer's data and performance during testing.
- (6) Determine physical requirements and/or technical training of personnel necessary for effective usage of the monitors.
- (7) Determine the versatility of each monitor with respect to the number of operational modes.

### 1.2 Background

At the present time, deck foam fire extinguishing systems for tank vessels are approved by the U. S. Coast Guard as total operating systems. Currently, systems using manually operated monitors are the only ones which have Coast Guard approval. An inherent problem with the manual monitor is the need to approach and operate it while it is being exposed to fire conditions (Figure 1). Locating the monitor close to the probable fire site in order to give it an effective range and a large area of coverage makes the problem more severe. One method of improving these systems could be the substitution of automated monitors. A deck foam system includes a centrally located



FIGURE 1  
FIRE CONDITIONS

TABLE 1

TESTED MONITOR EQUIPMENT AND MANUFACTURERS

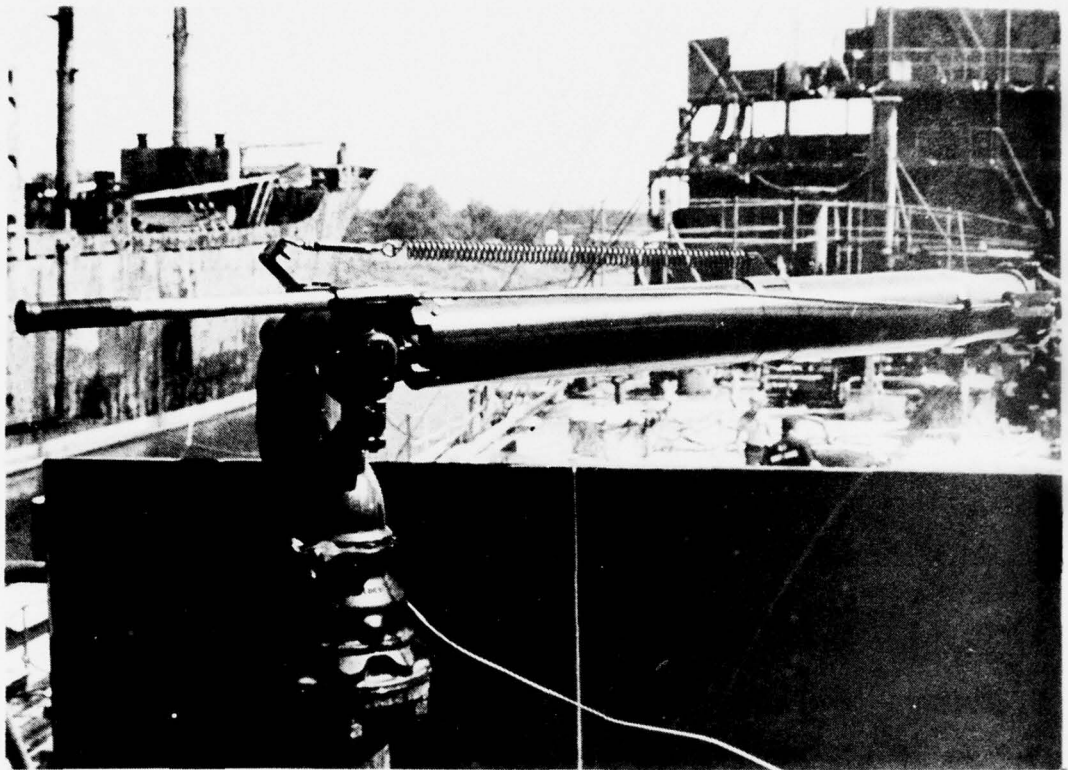

Manual

FV

Man

Feecon Co  
One Walk  
Westboro,

MONITOR EQUIPMENT

MODEL

CONTROL MODE

MANUFACTURER

Oscillating Monitor

OF-400

Oscillating and Manual

Feecon Corporation  
One Walkup Drive  
Westboro, MA 01581

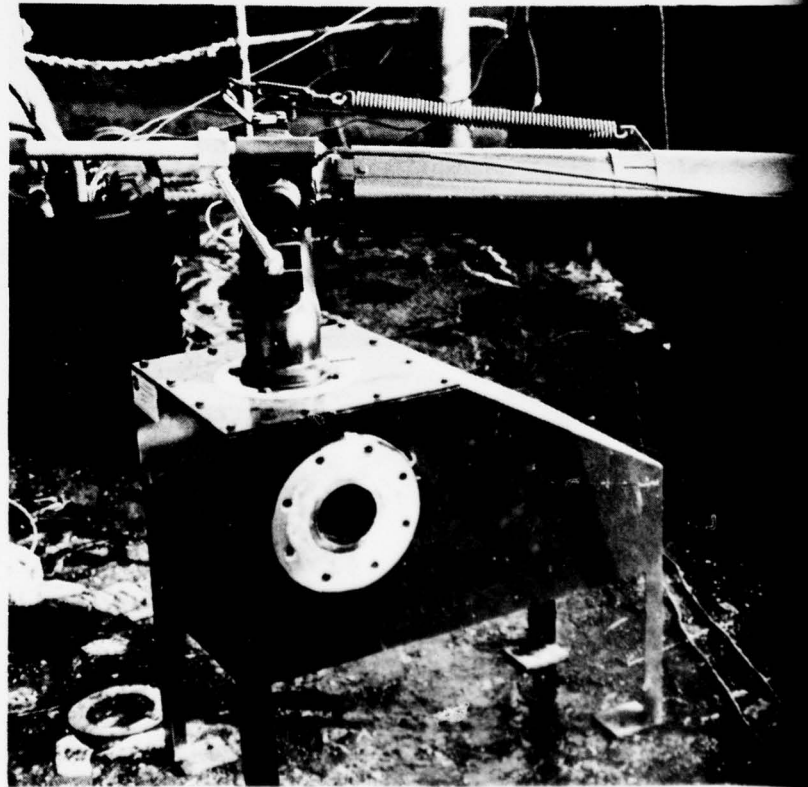

Manual Monitor

FVB-1

Manual

Seecon Corporation  
One Walkup Drive  
Westboro, MA 01581

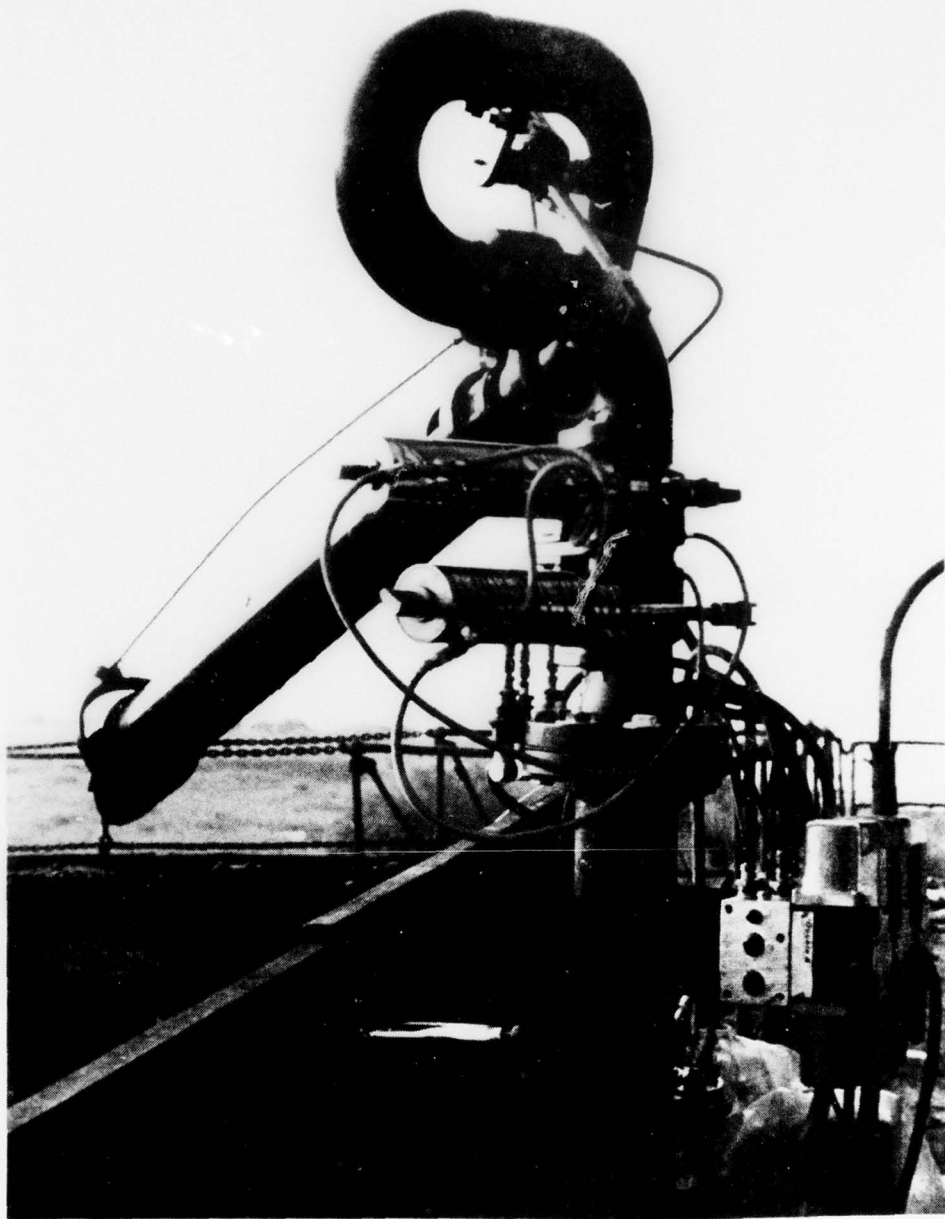

Remote Controlled (Hydraulic, Joystick) Monitor  
Joystick (No Manual Mode)

Stang Hydraulics, Inc.  
767 N. Main Street  
Orange, CA 92668

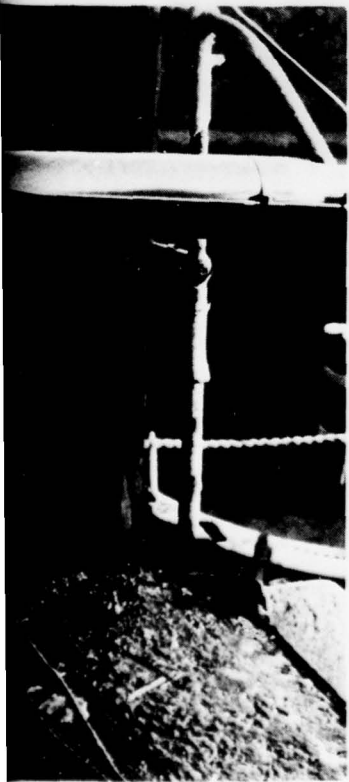

2

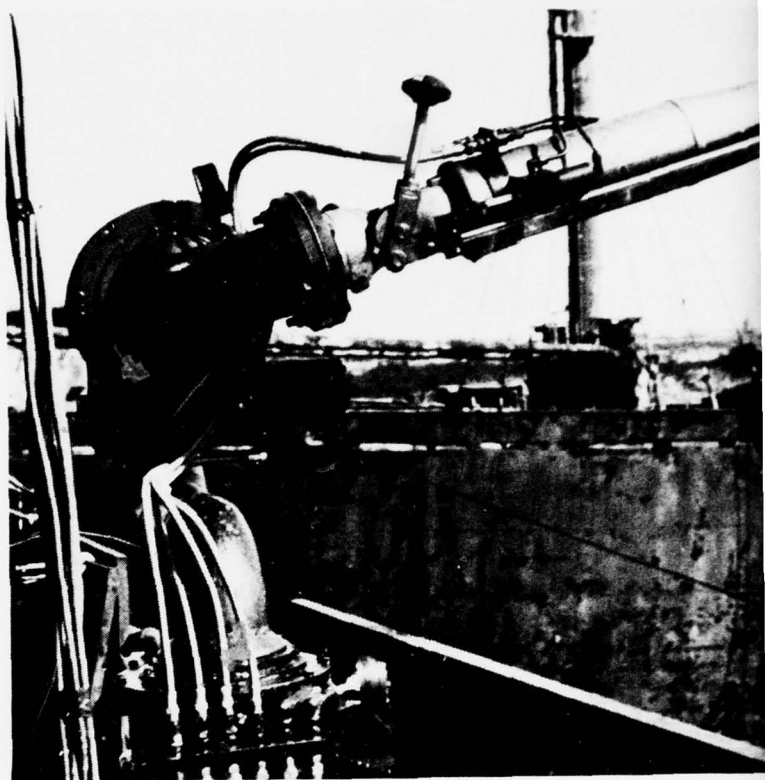

Servo-Controlled Monitor

S-6687

Servo-Controlled (Manual Mode Malfunctioned)

Rockwood Systems Corporation  
80 Second Street  
South Portland, MA 04106

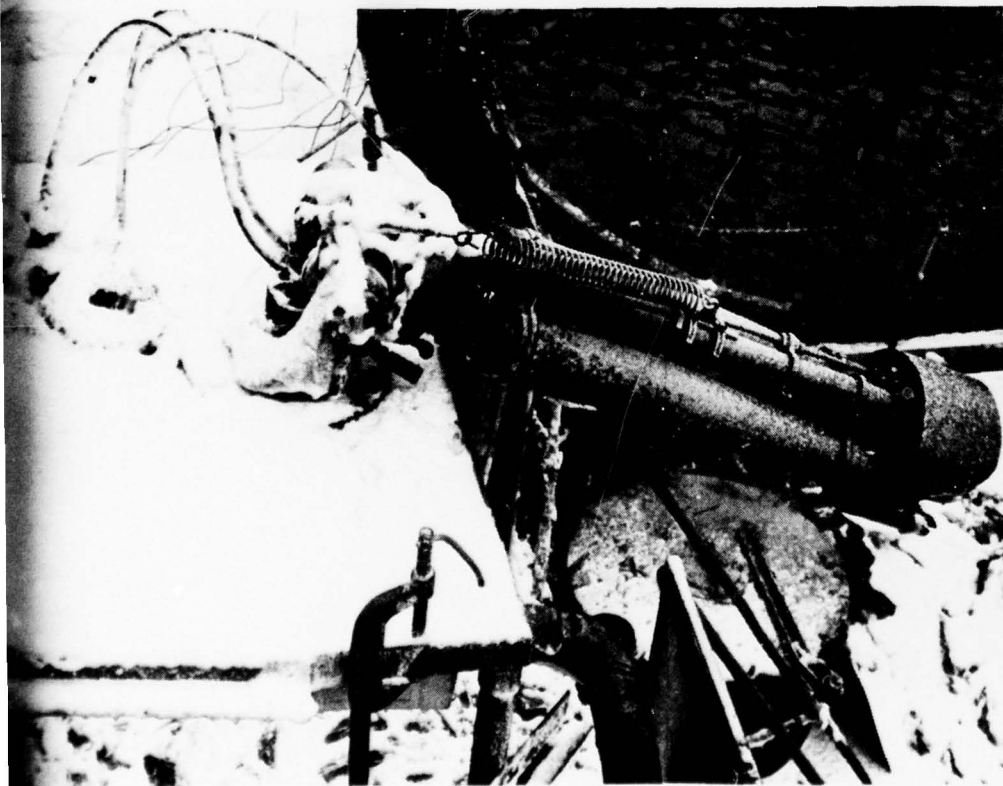

Programmed Automatic  
with Ultraviolet D

Automatic and J  
(No Manual M

National Foam Syst  
150 Gordon Dr  
Lionville, PA

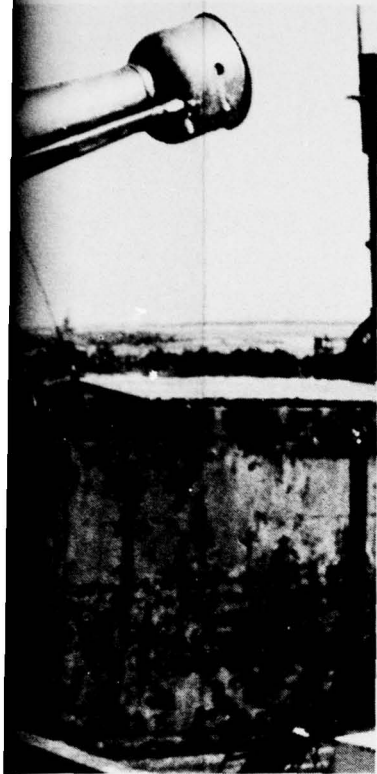

Remote Controlled Hydraulic Monitor  
(RCM-4S) with Discharge Tube (PC-50)

3 Lever, Pushbutton, or Joystick  
(No Manual Mode)

National Foam System, Inc.  
150 Gordon Drive  
Lionville, PA 19353

Automatic Monitor  
Outlet Detectors

and Joystick  
(Manual Mode)

System, Inc.  
on Drive  
PA 19353

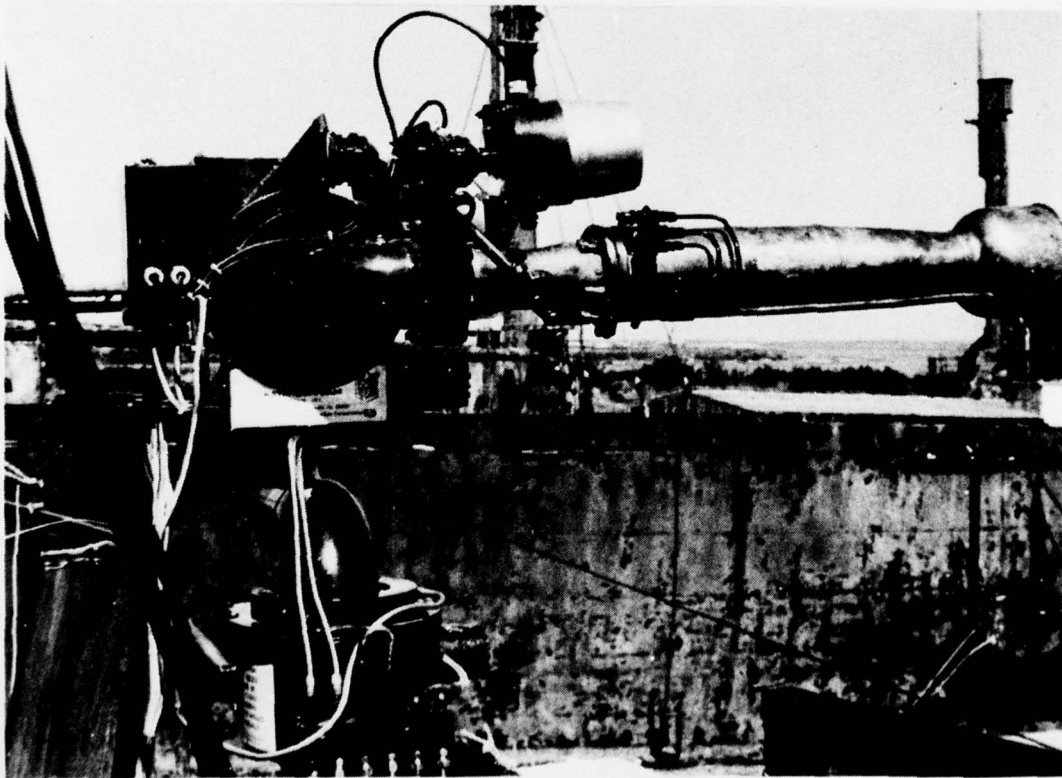

proportioner, or proportioners, permanent foam solution piping, and sufficient monitors and/or foam hydrants connected to the fire main for delivery of the minimum required application rate to any portion of the deck. Coast Guard Rules and Regulations for Tank Vessels, Title 46 CFR 34.20-5, state that the deck foam system on all ships with a keel-laying date on or after 1 January 1975 shall have a sufficient supply of foam concentrate to operate the system at its designed application rate of foam production for a period of at least 20 minutes without recharging. At least 50 percent of the required foam application rate shall be from fixed monitors. The most recently approved deck foam systems must be capable of being actuated within three minutes of notification of a fire. (See Title 46 CFR 34.10.)

### 1.3 Coast Guard Rules and Regulations

Deck foam systems installed on or after 1 January 1962, must conform to the Coast Guard Rules and Regulations for Tank Vessels, Title 46 CFR 34.20. Systems of this type are designed to give primary protection to the cargo tank tops. They must have a foam application rate of at least 0.016 gpm for each square foot of deck cargo area, or 0.24 gpm for each square foot of the horizontal sectional area of the single tank having the largest such area, whichever is greatest. The cargo area is defined as the maximum beam of the vessel times the longitudinal extent of the tank spaces. If upon testing the deck foam system produces in excess of the required foam application rate, the supply of foam concentrate is required to be increased to allow 20 minutes operation time at the actual application rate. One premise in the regulations is that it is improbable that a fire which burns for more than 20 minutes can be contained and extinguished by the vessel's crew. The foam agent and main controls for operating the system must be located in a protected space not likely to be made inaccessible in the event of a fire in any portion of the cargo area. The operation of the deck foam system must not interfere with simultaneous use of the fire main system.

### 1.4 Limitations

An inherent problem in any full-scale testing is the difficulty in duplicating all the variables which affect the results. This in turn leads to difficulty in the repeatability of test results and a potential loss of test credibility. In this program, each test was conducted three times to provide confidence and credibility in the results.

The automated monitors in these test were built for shore-side applications. This test series was conducted with the premise that the monitors might be adapted for use on board ship with minor changes in construction which would not affect their performance. All comments in this report regarding the monitors are based upon this premise.

## 2.0 TEST PROCEDURE FOR ALTERNATE MONITORS

### 2.1 Experimental Setup

The testing was conducted on board the T/V A. E. WATTS located at Little Sand Island at the U. S. Coast Guard Fire and Safety Test Facility in

Mobile, Alabama. A series of steel coamings, 21 inches high, were constructed on the port side of the after tank deck to form a network of shallow open fire pens (Figure 2). The total pen area was 1,665 square feet (55.5 feet long by 30 feet wide). This pen area was subdivided into two areas, one of 1,000 square feet and the other of 665 square feet (Figure 3). The total pen was used for conducting the pattern tests, maneuverability tests, foam depth tests, and fire tests.

Before the testing, an aluminum tank top was substituted for a steel one. This aluminum tank top was subjected to the fire tests to see if and under what conditions buckling or melting of the aluminum cover might occur. This testing was inconclusive but was continued and reported on separately.<sup>11</sup>

Each test monitor was installed on the 01 deck level of the after deckhouse and centered on the fire pens (Figure 3). The height of the monitors above the main deck was 15 feet. The horizontal distance from the monitor to the after edge of the fire pen was 22 feet. The operating panel for each remotely controlled monitor was located behind a heat shield on the 02 deck. This heat shield was fitted with protective glass to permit the monitor operator to view the test area (Figure 4). Proximity suits were used by personnel when necessary during the fire tests.

The foam system was typical of that installed aboard United States flag tank vessels and consisted of (Figure 5):

- (1) A foam concentrate tank
- (2) A foam concentrate pump
- (3) A balanced pressure proportioner
- (4) A piping system to distribute foam solution
- (5) A fixed-position monitor on the 01 deck
- (6) Three outlets for 2-1/2-inch hand-held lines, one on the aft 02 deck and two on the forward main deck.

The instrumentation used to measure foam expansion, drainage time, concentration, and pattern is described in Appendix A. The continuous pressure, temperature and flow measurements outlined in Figures 3, 5, and 6, as well as wind speed and wind direction, were made with the appropriate transducers and recorded on a digital recording system. Additional instrumentation included 16mm movie camera, 35mm still camera, stop watches, and a test time clock mounted on the test status board.

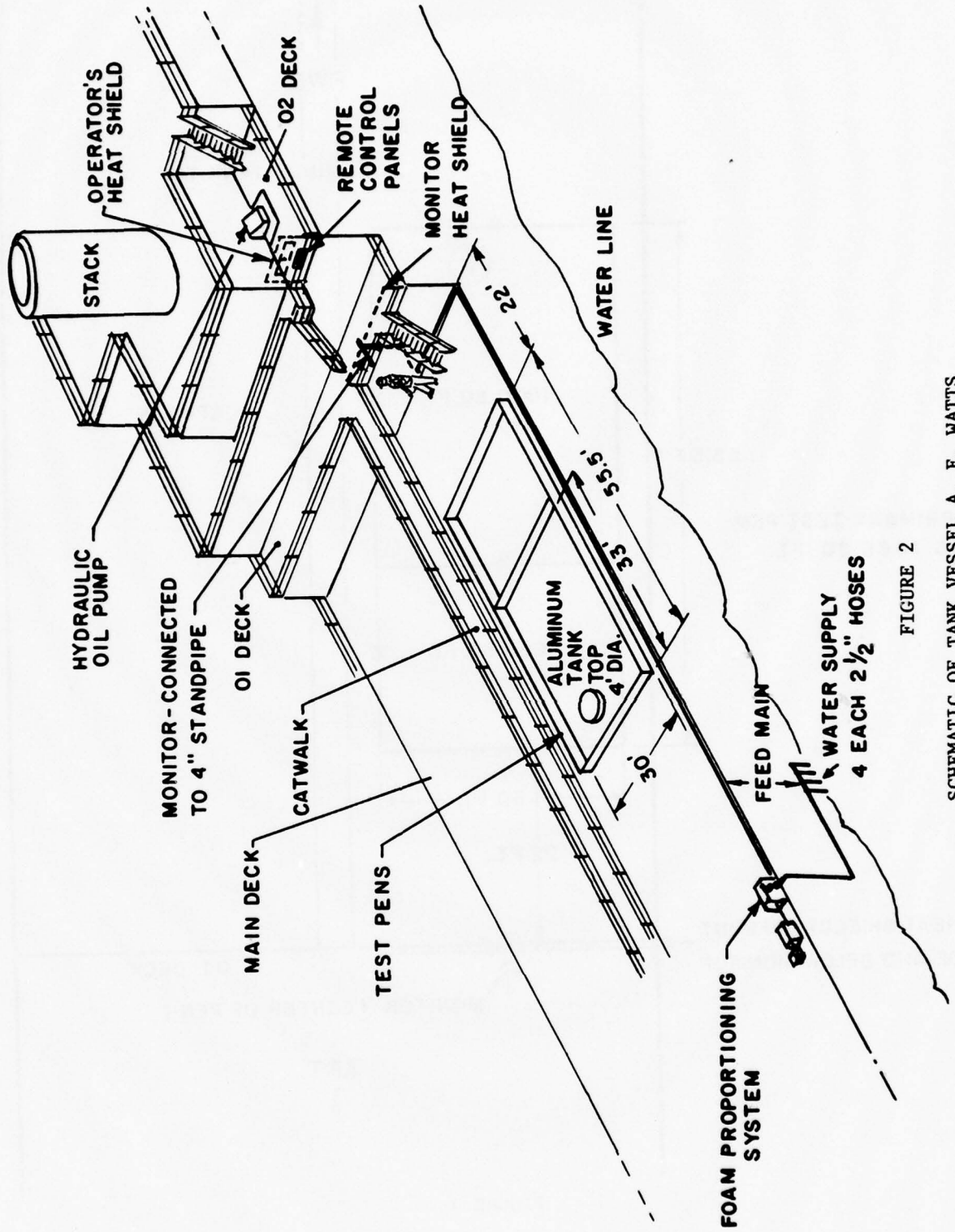

FIGURE 2

SCHEMATIC OF TANK VESSEL A. E. WATTS

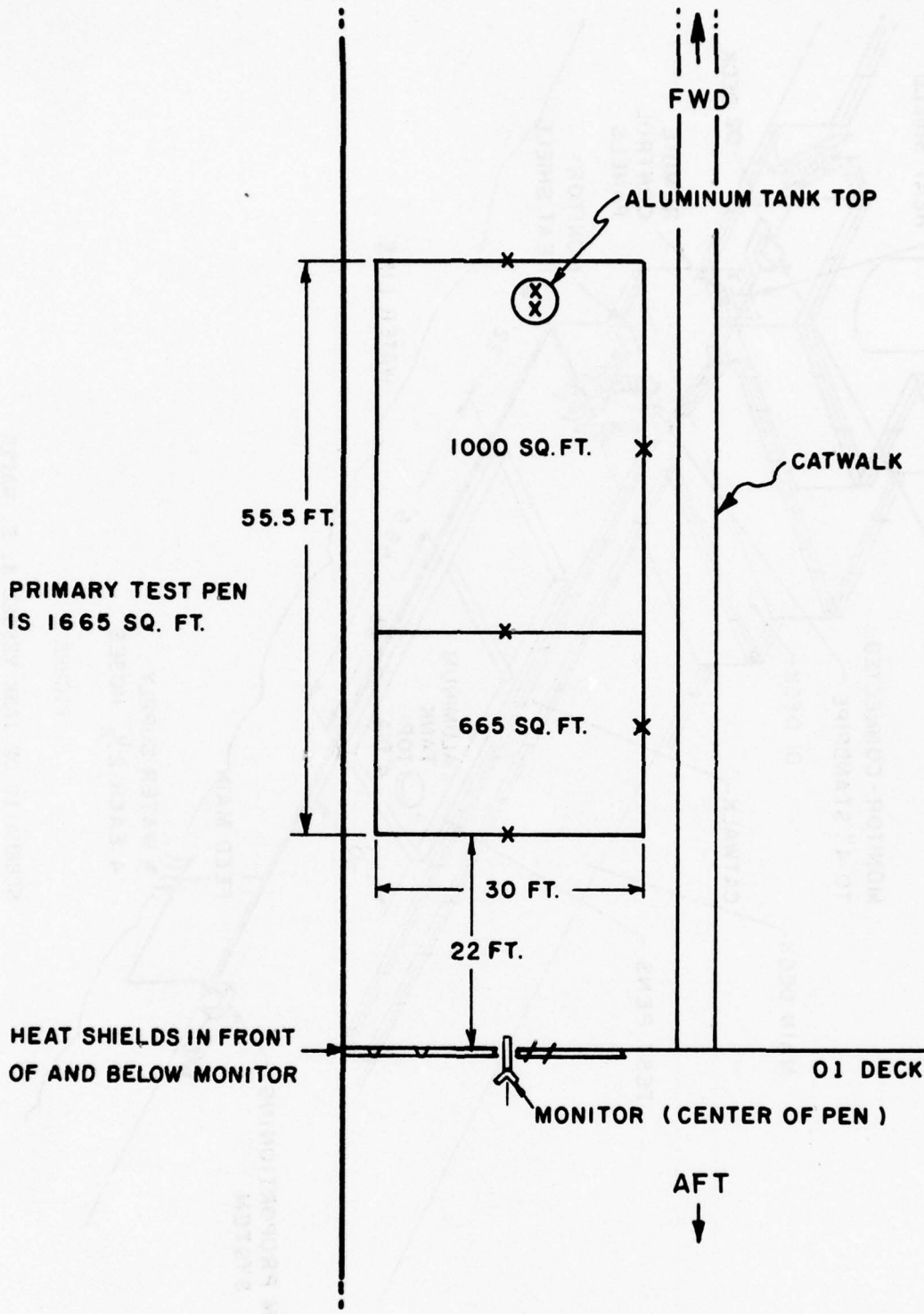

FIGURE 3

TEST PENS AND MONITOR LOCATION

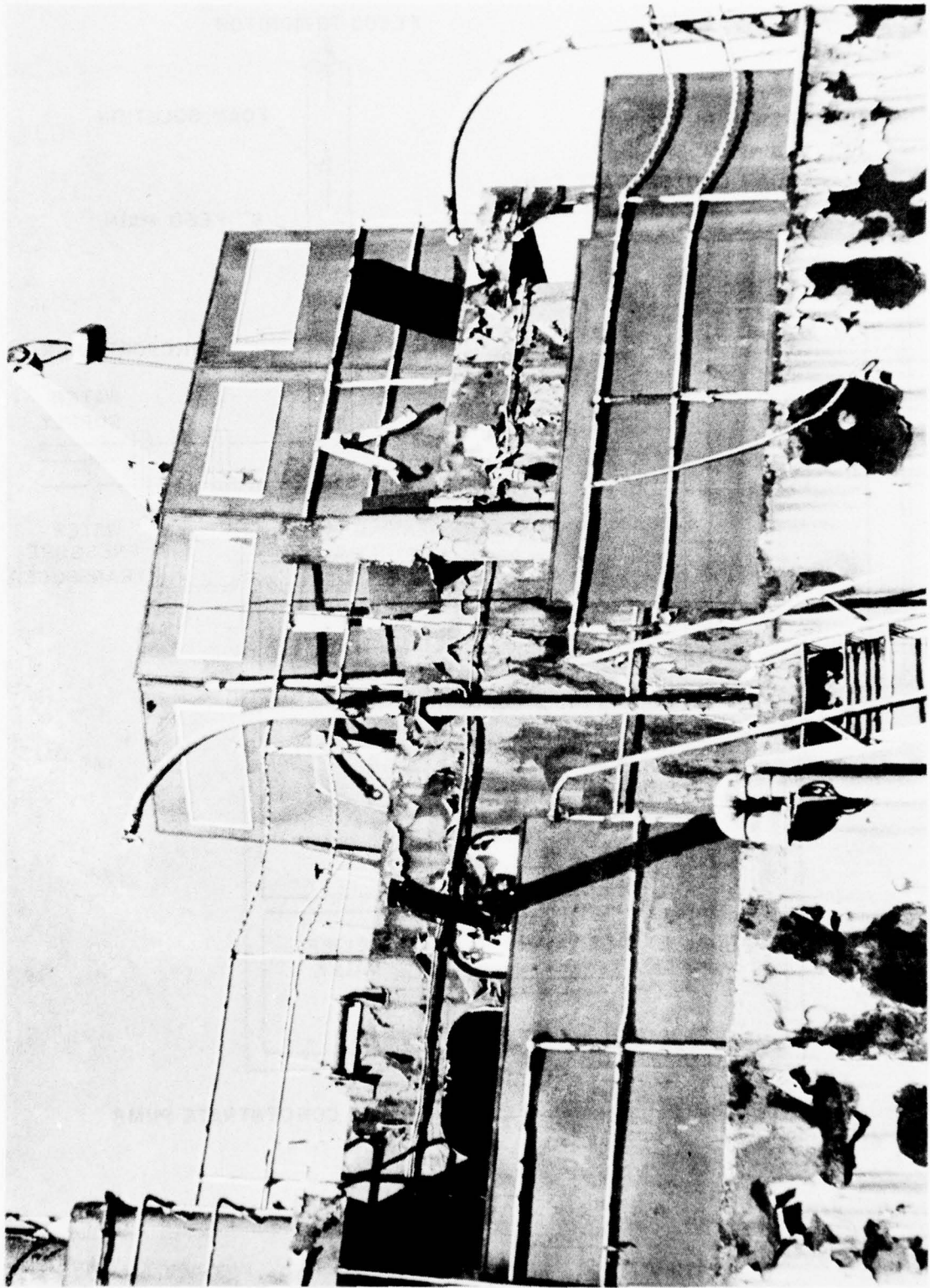

FIGURE 4

HEAT SHIELD FOR MONITOR OPERATOR

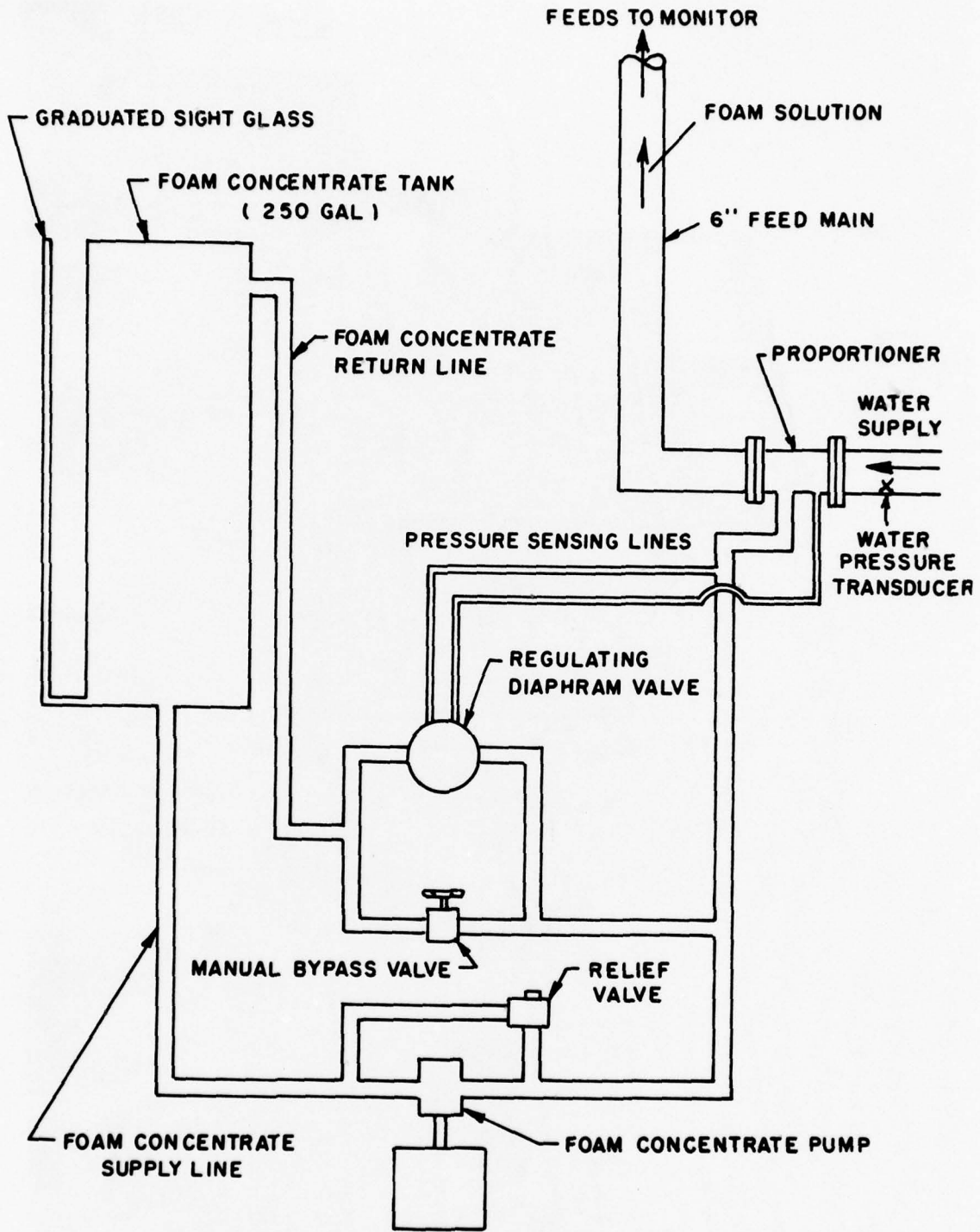

FIGURE 5  
PROPORTIONING SYSTEM

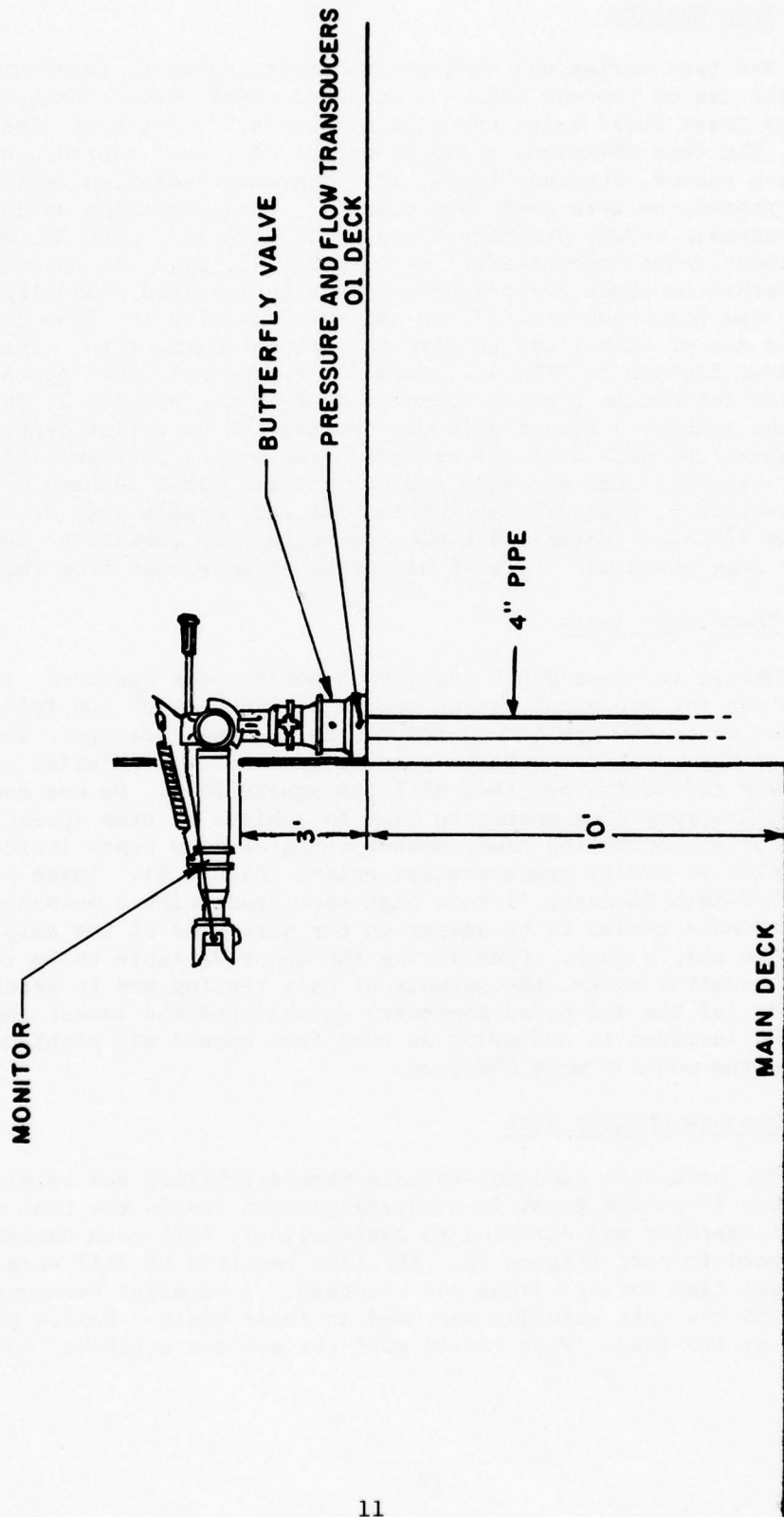

FIGURE 6  
MONITOR INSTRUMENTATION

## 2.2 Foam Quality

The test series was divided into four segments, three of which involved the use of protein foam. A standard three percent protein foam approved by Coast Guard Rules and Regulations (see "Equipment List" CG-190) was used. The foam solutions produced by the different monitors were compared by expansion ratios, drainage times, and foam/water solution ratios. The following procedures were used (Appendix A): foam expansion as in NFPA, 412, page 20, Appendix A-230; drainage times as in NFPA 142, page 20, Appendix A-240; proportioning concentration as in NFPA 142, page 22, Appendix A-250. A second method to check the proportioning rate involved measuring both the water flow and foam concentrate flow and then dividing the foam concentration flow by the sum of both flows to give the proportioning rate. Foam patterns were measured similar to NFPA 412, page 25, Appendix A-310. Appendix A-310 was modified for motion picture documentation of the results as follows: in place of the stakes, a wooden grid was constructed on 3-foot centers and elevated above the deck over the expected foam ground patterns (Figure 7). The lumber was 2x4's for strength and was painted black to help in assessing the foam pattern. This grid was located aft on the port side of the main deck of the T/V A. E. WATTS. A movie camera located forward on the 03 deck filmed the foam patterns. Pattern measurements were made from these films.

## 2.3 Foam Depth Tests

During the foam depth test, each monitor was operated in a straight stream pattern for one minute at an operating pressure of 100 PSIG. Flow had been planned to be 400 gpm but varied due to equipment design. The operator was instructed to spread the three percent protein foam solution as evenly as possible over the entire pen area of 1,665 square feet. He was continually informed of his remaining operating time to achieve an even spreading of foam. At the end of the operating time, measurements of foam depth inside the test pen were taken at twenty predetermined points (Figure 8). These points were marked by 1/2-inch diameter, 1-foot high steel rods with a 6-inch square base. Foam measurements tended to be deeper on the port side of the ship due to the camber of the ship's deck. Considering the major variable to be the different operational control modes, the purpose of this testing was to determine which control mode (of the automated monitors) established the lowest foam wastage. Difficulties involved in achieving an even foam spread and problems of maneuvering the monitor were observed.

## 2.4 Maneuverability Test

The procedure used to evaluate maneuverability was to place an array of four 25-gallon drums in a zigzag pattern inside the test pen area. The monitor operator was directed to consecutively fill each numbered drum from starboard to port (Figure 9). The time required to fill each drum and the total time for all drums was recorded. A straight stream pattern with water as the test solution was used in these tests. Nozzle pressure was maintained at 100 PSIG. Flow varied with the monitor equipment tested. This

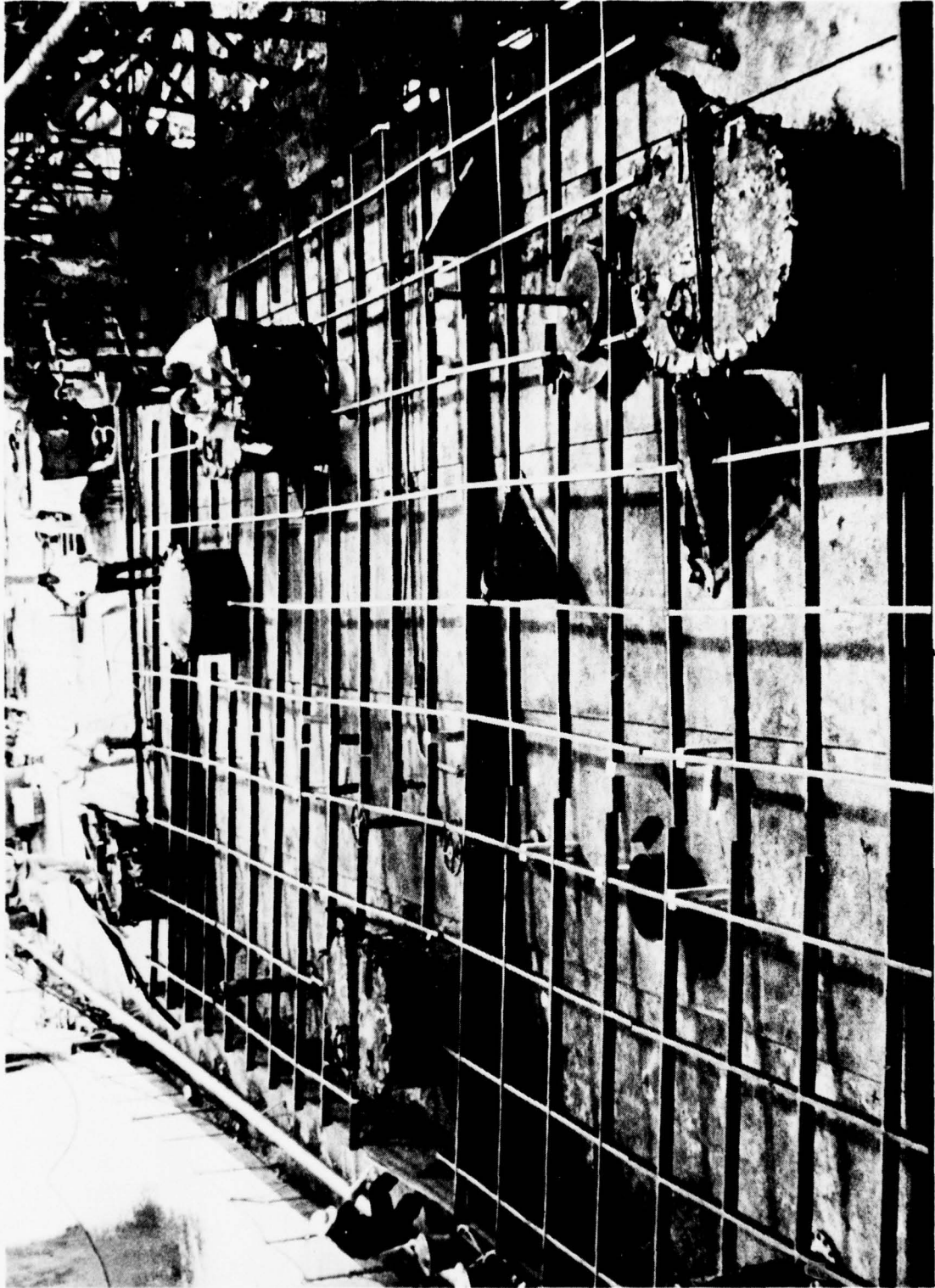
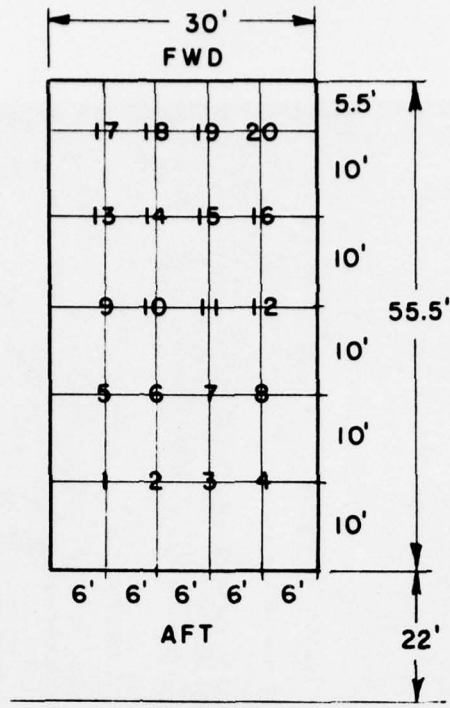

FIGURE 7  
GRID PATTERN LAYOUT



O1 DECK

FIGURE 8

FOAM DEPTH MEASUREMENT POINTS

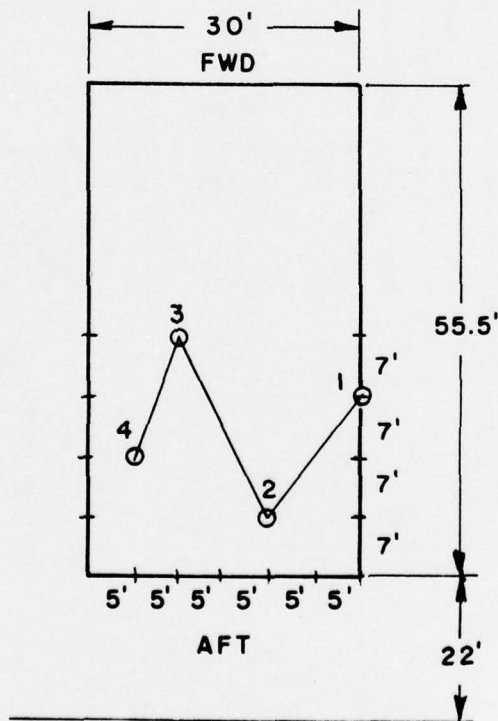

O1 DECK

FIGURE 9

MANEUVERABILITY TEST PATTERN



FIGURE 10  
MANEUVERABILITY TEST IN PROGRESS

test was designed to compare operating times and difficulties of the different control modes by imposing similar requirements necessary for combatting a fire.

## 2.5 Fire Test

During the fire test, each monitor was tested in its primary operational mode. If extinguishment in this mode was not achieved, then the alternate control mode was used (Table 2). The 1,665 square foot fire pen was used. Nozzle pressure was 100 PSIG. Three percent protein foam was the extinguishing agent. Flow was dependent upon each monitor's characteristics. The fire area was filled with water to a depth of 2 to 4 inches below the top of the coaming. The test fuel, JP-5, was floated on the water's surface, its depth ranging from 1 to 2 inches. Floating the test fuel on the water surface removed the effect of the ship's camber thereby allowing the fuel surface to cover the entire test pen area except for the existing tank top and deck obstacles. Since JP-5 has a flashpoint of 140°F, several gallons of naptha were used to help ignite it. The naptha was ignited in various corners of the fire pens depending on the wind conditions. Standard signal flares were used to ignite the naptha. Fire spread across the entire pen surface in 2 to 4 minutes depending on wind conditions. A one-minute full involvement preburn was allowed before foam application was started (Figure 11). Prior to the ignition of the naptha, the foam system and lines were charged. Foam discharge was initiated by opening a butterfly valve located at the base of the monitor. This was done at the completion of the one-minute preburn, by an individual in a proximity suit. Control time of the fire was defined as the period from foam application until it was evident that the fire offered no further danger to the vessel assuming that eventual extinguishment was made. This condition corresponded to a point where the flames covered no more than 10 percent of the fuel surface. Extinguishment time was defined as the time from foam application until all fire in the test pens was out. This did not include minor fires outside the test pens which continued to burn.

## 2.6 Time Study

The activation of any deck foam system begins with the detection of the fire. For all ships built on or after 1 January 1975, U. S. Coast Guard Rules and Regulations state that a deck foam system must be operational within three minutes. The three-minute time applies to the process of placing the system into service, which includes opening all valves, starting the fire pump, and turning on the foam proportioner. One time study will show the time necessary for the monitor operator to approach and start-up the monitor. Broken down further, this involved the operator's times required to swiftly traverse different distances, climb a 10-foot ladder, and open a monitor solution control valve. Since this assignment would be conducted under emergency conditions, the monitor operator performed these duties at a faster than normal work rate, but at a pace not rapid enough to create additional safety problems. One of the major problems in operating the manual monitor is exposing its unprotected operator to the heat flux from the fire. This problem might be altered if enough time were taken to protectively clothe the monitor operator. This one time study will show the time required to don different items of protective firefighting gear.

TABLE 2

OPERATIONAL CONTROL MODES USED DURING TESTS

MONITORS		MANUAL	OSCILLATING	REMOTE CONTROLLED (HYDRAULIC, JOYSTICK)	REMOTE CONTROLLED (ELECTRIC, PUSHBUTTON)	REMOTE CONTROLLED (HYDRAULIC, 3 LEVER)	SERVO-CONTROLLED	PAM
TESTS		MANUAL	OSCILLATING	REMOTE CONTROLLED (HYDRAULIC, JOYSTICK)	REMOTE CONTROLLED (ELECTRIC, PUSHBUTTON)	REMOTE CONTROLLED (HYDRAULIC, 3 LEVER)	SERVO-CONTROLLED	PAM
FOAM		MANUAL	OSCILLATING	REMOTE	REMOTE	REMOTE	REMOTE	NONE
MANEUVERABILITY		MANUAL	OSCILLATING AND MANUAL	REMOTE	REMOTE	REMOTE	REMOTE	REMOTE
FIRE		MANUAL	OSCILLATING AND MANUAL*	REMOTE	REMOTE	REMOTE	REMOTE	AUTOMATIC, OSCILLATING AND REMOTE*

\*If necessary due to primary mode failing to control fire

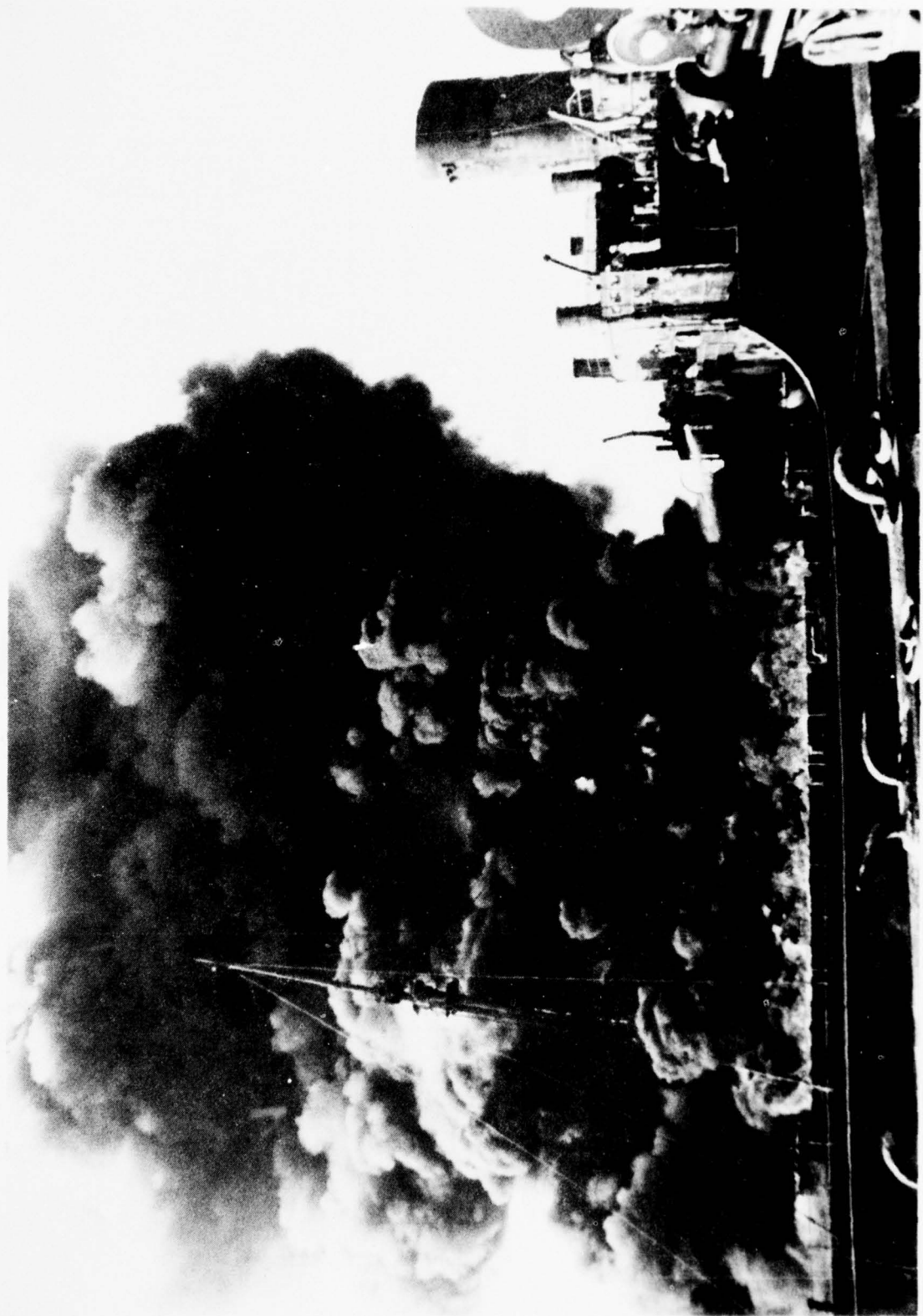

FIGURE 11  
ONE-MINUTE FULL INVOLVEMENT PREBURN OF FIRE

This extra time could permit the operator to reach the monitor in spite of severe radiant heat problems. For the test case, the protective clothing was located en route to the monitor. The conditions under which the protective gear was donned assumed the operator had only to raise the lid on a storage locker, reach inside, seize the gear, and put it on.

### 2.7 Operational Ease and Versatility

Strength, weight, and manual dexterity needed by the operators were noted as the monitors were operated. The complexity of control devices and the difficulty involved in control manipulation were observed. The control panels were examined for simplicity of layout and whether training or written instruction would be necessary to effectively operate them. Each monitor was operated in all of its modes. The various operational modes were examined, evaluated, and compared (Table 2). Observations on the difficulties and problems encountered in each operational mode were recorded.

### 2.8 Serviceability, Reliability, and Durability

As each monitor was installed, its various components were examined. Comments on possible areas of failure due to materials, construction and design were recorded. Any difficulties with installation and equipment adjustment were recorded. Any specialized tools or training necessary for installation and servicing were noted. During testing the reliability of the monitors to perform in their various modes was recorded.

## 3.0 TEST RESULTS AND EVALUATION OF MONITORS

Detailed results of individual tests are listed and described in the following test summaries.

### 3.1 Foam Quality and Patterns

Foam quality is primarily a function of equipment design. This design can be mechanically altered to produce different levels of quality. Foam quality results (Table 3) are based on the mean of the observations for each item of tested equipment. Note that the foam expansion ratios and 25 percent drainage times for the monitors tested ran slightly lower than the minimum acceptable foam quality values listed in the NFPA 412 Codes. This was true even for the Coast Guard-approved manual monitor. The percent plus or minus deviation for the different foam quality columns was calculated by comparing the highest or lowest single deviation to the mean of the observations. One explanation for the low mean of foam quality values could be the usage of sea water in monitor equipment designed for freshwater application. Another explanation is the possible chemical breakdown of the foam because of detergents and other industrial waste products known to be present in Mobile Bay. For example, a previous sample analysis by a state-approved laboratory has reported twice the norm of detergent compounds in Mobile Bay as found in unpolluted sea water.

TABLE 3  
FOAM QUALITY RESULTS

EQUIPMENT	OBSERVATIONS	PROPORTIONING RATE (±23%)	EXPANSION RATIO (±27%)	25% DRAINAGE IN MINUTES (±28%)
Manual Monitor	7	4.2	7.0	3.8
Oscillating Monitor	7	4.2	7.1	4.8
Servo-Controlled Monitor	6	4.2	5.4	1.8
Remote Controlled (Electric, Pushbutton) Monitor	6	4.3	5.4	1.4
Remote Controlled (Hydraulic, 3 Lever) Monitor	7	4.2	6.5	1.4
Remote Controlled (Hydraulic, Joystick) Monitor	7	3.3	7.9	2.5
Programmed Automatic Monitor	3	3.3	5.2	1.5
Minimum Accepted Values in NFPA 412 Codes			8	4

Based on the collected data, the oscillating monitor and the remote controlled (hydraulic, joystick) monitor produced foam expansion ratios and drainage times most equivalent to the Coast Guard-approved manual monitor. Since the required foam quality results can be achieved with either the automated or manual monitor through existing technology, foam quality does not play a critical role in the comparisons of the different monitors.

The foam pattern tests were designed to obtain the pattern of the straight stream and fog discharges inherent to each monitor (Figure 12). Foam depths were not measured but it was noted that the deeper foam depths were within 15 feet of the maximum reach of the solution discharge. Straight stream distances were impractical to accurately measure on board the test ship because of existing deck obstructions. Straight stream patterns for all tested monitors were similar to the manual monitor, but only the oscillating monitor, the servo-controlled monitor, and the remote controlled (hydraulic, joystick) monitor produced a fog pattern which matched the manual monitor in width and distance.

Foam patterns are primarily a function of engineering design. Through existing technology, it is possible to produce a specific pattern to meet reasonable acceptance criteria. This is true both for a straight stream and a fog pattern.

It is conceivable that fog patterns would not be a necessary requirement for automated monitors. Since fog patterns are primarily used for operator protection and since the operator of an automated monitor would be located at a safe and protected distance from the monitor, the fog pattern would have little value except in a manual override situation. With existing technology capable of producing varied levels of foam quality and based on the similar results achieved for manual and automated monitors in the foam quality and pattern tests, the approval of automated monitors based on these approval criteria appears possible.

### 3.2 Comparative Foam Depths

Using its primary control mode, each monitor was operated for one minute. During this time, 3 percent protein foam was spread as evenly as possible into the 1,665 square foot test pen. The foam depth was quickly measured and recorded at 20 predetermined points. The original plan was to measure the average foam depth produced by each monitor, then to compare each monitor's average depth to that produced by the Coast Guard-approved manual monitor. The difference in average foam depth in the pen could be mathematically converted to percent foam wastage inherent in the individual control modes thus the control mode would be the major variable. However, since the measured average foam depths far surpassed the theoretically calculated average depths; it became impossible to quantitatively compare foam waste. Visual observation of the foam loss outside the test pen was then rated on a high/low scale. The observations were made by test personnel and by studying the 16mm motion pictures taken of the tests.

The high flow rates and pressure discharge created deep foam ridges. The distribution of these deep ridges could not be accounted for in an arithmetic mean. It is believed that this caused the measured depths to be greater than the theoretically possible depths. Again, the contaminants in the test water might significantly affect the foam depth.

Before compiling the scale showing foam wastage as related to the individual control modes, a few explanations are in order. The automated monitors were compared to each other and to the manual monitor in terms of foam wastage. Even though physically operated, the manual monitor incurred some foam waste. The oscillating monitor could be preset in order to give zero wastage inside an area, but should the fire only occur in a portion of the designated area, the foam wastage would depend upon the fire location.

Wastage with the servo-controlled monitor tended to be high for two reasons. First, the monitor tended to track upward and unless the operator paid close attention, he would be off-target through no fault of his own. Second, the operator was constantly being showered by foam kickback off the monitor discharge tube. In trying to avoid the foam shower, he could not concentrate or see to perform his task. This situation could be corrected when the monitor is properly installed on a ship. The hydraulic oil piston-driven monitors (the servo-controlled and joystick controlled units) reflected the operator's quickness and forcefulness at the controls, while the oil worm gear-driven monitors (the 3-lever controlled and pushbutton controlled units) were slightly slower but consistently more accurate in their response to the controlling motion. It was found that control modes with certain movement restrictions often contributed to more precise foam placement than control modes with more liberal movement (Table 4).

TABLE 4

MONITOR CONTROL MODES RANKED BY INCREASING FOAM WASTAGE

1. Oscillating	Least
2. Manual	
3. Remote Controlled (Hydraulic, 3 Lever)	
4. Remote Controlled (Hydraulic, Joystick)	
5. Remote Controlled (Electric, Pushbutton)	
6. Servo-Controlled	Most

This ranking shows which control mode in a non-fire situation was most efficient in depositing foam over a specified area. It does not consider a fire situation which adds numerous variables such as the fire's physiological effects on the monitor operator and the changing fire area. Should an automated monitor be approved, the control mode for efficient foam placement should be considered not by itself but in conjunction with effective fire control and extinguishment.

MONITOR: Remote Controlled  
(Hydraulic, Joystick)

TEST #: 2  
 FOAM CONCENTRATE: 3% Protein Foam  
 NOZZLE PRESSURE: 100 psi  
 SOLUTION FLOW RATE: 245 gpm  
 APPLICATION RATE: .14 gpm/sq ft  
 FOAM EXPANSION #: 8.5  
 25% DRAINAGE TIME: 3.1 minutes  
 DATE: 28 September 1976  
 WIND VELOCITY: 0 to 2 mph  
 WIND DIRECTION: NE  
 AIR TEMP: 33°C  
 WATER TEMP: 29°C  
 PROPORTIONING RATE: 3.1%

MONITOR: Oscillating

TEST #: 9  
 FOAM CONCENTRATE: 3% Protein Foam  
 NOZZLE PRESSURE: 100 psi  
 SOLUTION FLOW RATE: 300 gpm  
 APPLICATION RATE: .17 gpm/sq ft  
 FOAM EXPANSION #: 7.2  
 25% DRAINAGE TIME: 4.4 minutes  
 DATE: 2 October 1976  
 WIND VELOCITY: 0 to 1 mph  
 WIND DIRECTION: NW  
 AIR TEMP: 30°C  
 WATER TEMP: 29°C  
 PROPORTIONING RATE: 5.2%

LEG  
 95% D  
 5% F

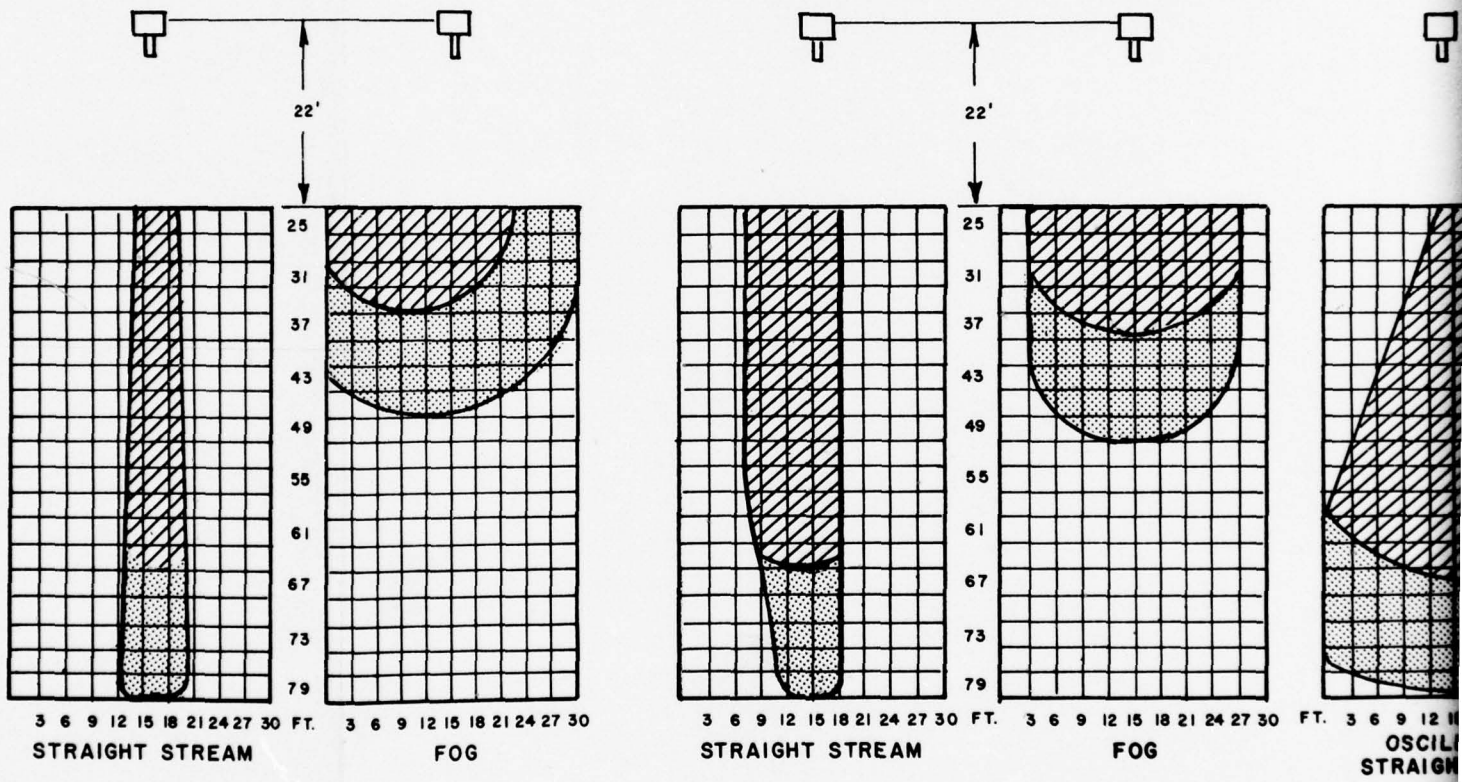

FIGURE 12

GRID PATTERNS FOR TESTED MONITORS

MONITOR: Manual

MONITOR: Servo-Controlled

TEST #: 10  
 FOAM CONCENTRATE: 3% Protein Foam  
 NOZZLE PRESSURE: 100 psi  
 SOLUTION FLOW RATE: 350 gpm  
 APPLICATION RATE: 0.20 gpm/sq ft  
 FOAM EXPANSION #: 7.3  
 25% DRAINAGE TIME: 3.4 minutes  
 DATE: 2 October 1976  
 WIND VELOCITY: 0 to 2 mph  
 WIND DIRECTION: NE  
 AIR TEMP: 34°C  
 WATER TEMP: 29°C  
 PROPORTIONING RATE: 4.9%

TEST #: 16  
 FOAM CONCENTRATE: 3% Protein Foam  
 NOZZLE PRESSURE: 100 psi  
 SOLUTION FLOW RATE: 405 gpm  
 APPLICATION RATE: .24 gpm/sq ft  
 FOAM EXPANSION #: 4.5  
 25% DRAINAGE TIME: <1.0 minutes  
 DATE: 6 October 1976  
 WIND VELOCITY: 1 to 4 mph  
 WIND DIRECTION: NW  
 AIR TEMP: 27°C  
 WATER TEMP: 27°C  
 PROPORTIONING RATE: 2.1%

**LEGEND**

**FOAM**  
95% DISCHARGE

**FOAM**  
5% DISCHARGE



22'

22'

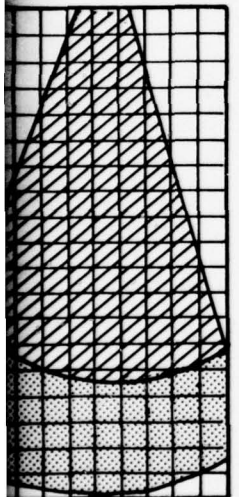

OSCILLATING  
STRAIGHT STREAM

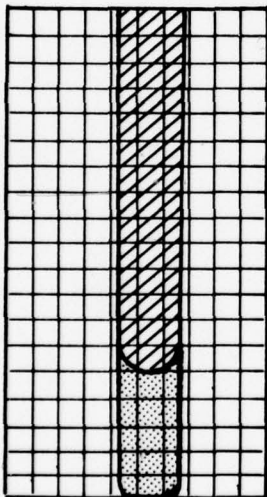

STRAIGHT STREAM

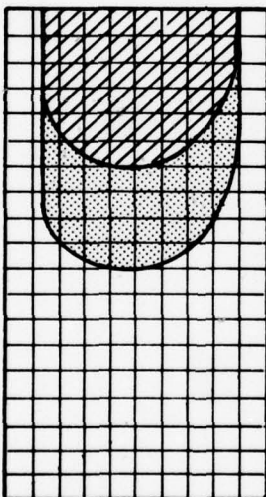

FOG



22'

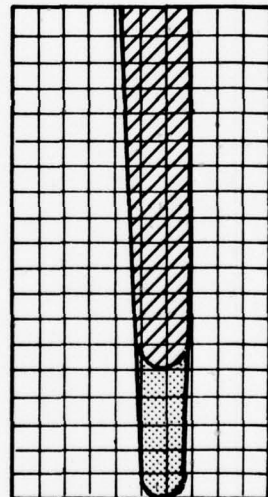

STRAIGHT STREAM

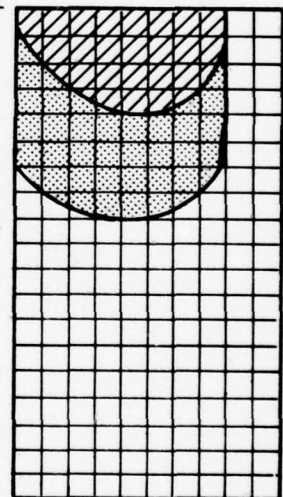

FOG

2

MONITOR: Servo-Controlled

TEST #: 16  
FOAM CONCENTRATE: 3% Protein Foam  
NOZZLE PRESSURE: 100 psi  
SOLUTION FLOW RATE: 405 gpm  
APPLICATION RATE: .24 gpm/sq ft  
FOAM EXPANSION #: 4.5  
25% DRAINAGE TIME: <1.0 minutes  
DATE: 6 October 1976  
WIND VELOCITY: 1 to 4 mph  
WIND DIRECTION: NW  
AIR TEMP: 27°C  
WATER TEMP: 27°C  
PROPORTIONING RATE: 2.1%

MONITOR: Remote Controlled  
(Hydraulic and Electric)

TEST #: 24  
FOAM CONCENTRATE: 3% Protein Foam  
NOZZLE PRESSURE: 100 psi  
SOLUTION FLOW RATE: 280 gpm  
APPLICATION RATE: .16 gpm/sq ft  
FOAM EXPANSION #: 8.4  
25% DRAINAGE TIME: 1.4 minutes  
DATE: 11 October 1976  
WIND VELOCITY: 0 to 2 mph  
WIND DIRECTION: NE  
AIR TEMP: 22°C  
WATER TEMP: 23°C  
PROPORTIONING RATE: 4.4%

n Foam  
sq ft  
tes

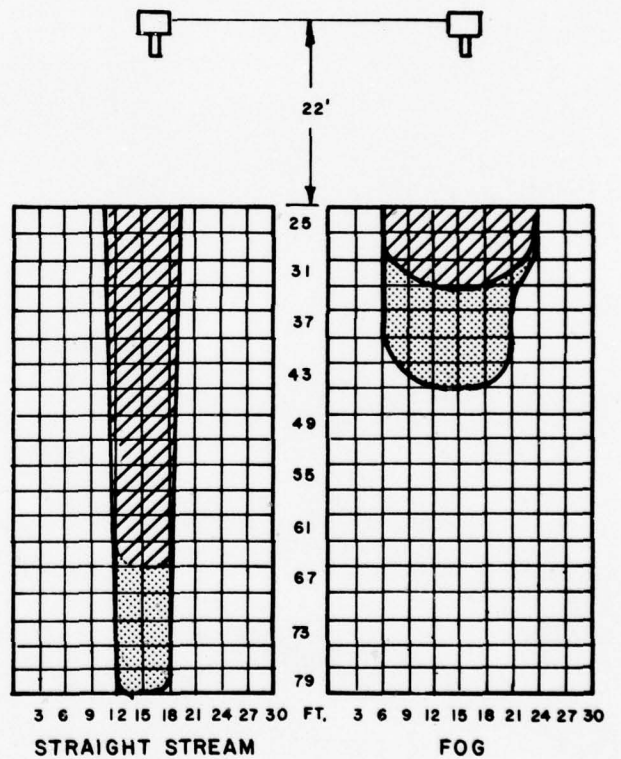
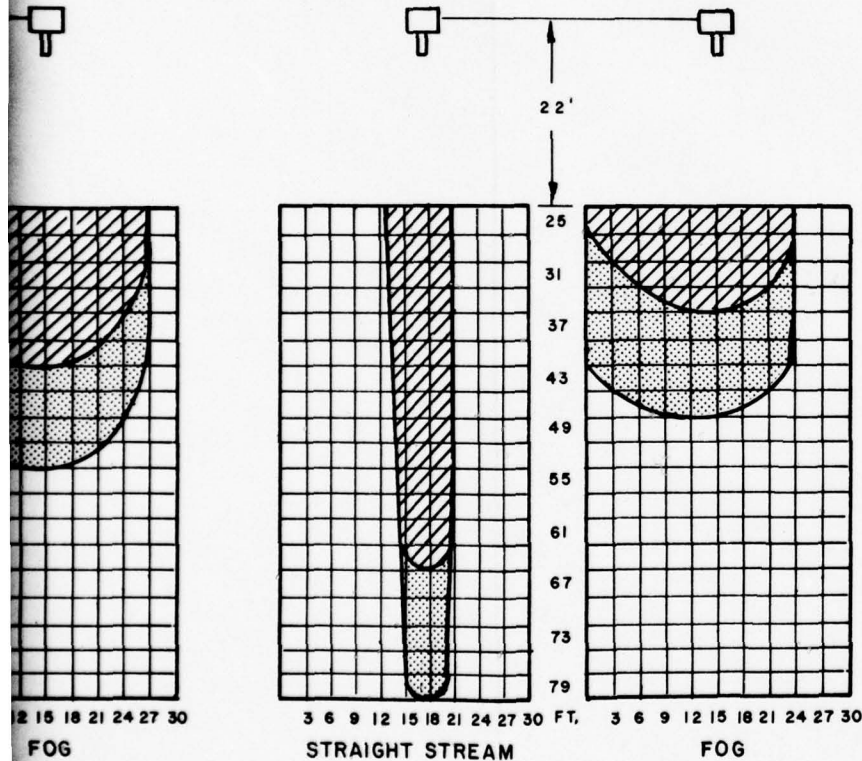

### 3.3 Comparative Maneuverability Times

The maneuverability tests were designed to confront the monitor control modes with a fire problem. The test consisted of consecutively filling an array of numbered 25-gallon drums arranged in a zigzag pattern across the test pen. They were to be filled in the shortest possible time. The results are recorded in Table 5. Depending on the type of control mode used, the remote control monitors required from 0 to 250 percent more time than the manual monitor in the maneuverability tests.

For this test, the volume of all the test barrels is constant and since,

$$\text{Flow (GPM)} \times \text{Time (Min)} = \text{Volume (GAL)}$$

GPM = gallons per minute

GAL = Gallons

thus,

$$\text{Flow}_{\text{Manual}} \times \text{Time}_{\text{Manual}} = \text{Flow}_{\text{Oscillating}} \times \text{Time}_{\text{Oscillating}} = \text{Flow}_{\text{PAM}} \times \text{Time}_{\text{PAM}}$$

Since we used the manual monitor as a reference, then adjusted operating times can be calculated for the differences in flows by the following formula;

$$(\text{Average Time}) \times \frac{\text{Flow}_{\text{monitor in question}}}{\text{Flow}_{\text{manual monitor}}} = \text{Adjusted Operating Time}$$

The primary reasons why the automated monitors required longer filling times than the manual monitor were that the water spray obscured the target and greater control was needed to cover such a small target. Target obscurity is not likely to occur in a fire condition nor is precise monitor control needed throughout a fire.

Looking at the maneuverability times alone would give misleading results as to which control mode supplied the more effective overall maneuverability. Other questions to be answered were (1) which mode seemed more responsive to operator demands, (2) what time was required for the different control modes to move the monitor from target to target, and (3) what operator dexterity problems were observed with individual control modes. Combining all of these factors, we rated the remote control (hydraulic, joystick) mode as the simplest to operate, most operator desired, most accurate and most effective in converting operator commands to monitor movements. This control mode operated approximately 20 percent more efficiently than the other automated control modes. The oscillating monitor could not be programmed to fill the entire pattern of barrels, although when switched to its manual mode, it duplicated the manual monitor's results.

TABLE 5

## MANEUVERABILITY TIMES

EQUIPMENT	OPERATIONAL CONTROL MODE	NUMBER OF TESTS	FLOW (gpm)	AVERAGE TIME MINUTES:SECONDS	AVERAGE TIME ADJUSTED FOR DIFFERENT FLOW RATES MINUTES:SECONDS
Manual Monitor	Manual	3	350	0:43	0:43
Oscillating Monitor	Manual	3	360	0:42	0:43
Oscillating Monitor	Oscillating (time to fill one barrel)	3	360	3:40	3:46
Servo-Controlled Monitor	Servo-Controlled (spray obscured target)	3	390	1:37	1:48
Remote Controlled (Electric, Pushbutton) Monitor	Remote Controlled Electric Pushbutton	3	310	1:02	0:55
Remote Controlled (Hydraulic, 3 Lever) Monitor	Remote Controlled Hydraulic 3 Lever	3	310	1:00	0:53
Remote Controlled (Hydraulic, Joystick) Monitor	Remote Controlled Hydraulic Joystick (panel position and water spray obscured target)	3	265	2:32	1:45
Programmed Automatic Monitor	Joystick	3	335	0:45	0:43

The servo-controlled mode, the remote controlled (hydraulic, three lever) mode, and the remote controlled (electric, pushbutton) mode were similar to each other but less efficient than the remote controlled (hydraulic, joystick) units in meeting overall maneuverability demands. In considering the automated systems for approval, the maneuverability capabilities are very important because poor maneuverability will result in longer control and extinguishment times.

#### 3.4 Control and Extinguishment Times

The control and extinguishment times for all the fire tests are listed in Table 6. Each fire test covered 1,665 square feet and had a fully involved preburn of one minute. Note that each monitor's application rate was well above the established fire extinguishing rate of 0.06 gpm/square foot. In McDaniel's report on extinguishing deck fires with a manual monitor,<sup>1</sup> he arrived at limiting curves for the relationship between application rate and control or extinguishment times. By displaying these curves with the application rate versus the control time and extinguishment time data of the automated monitors, we find that the automated monitors are capable of extinguishment times which are shorter than these curves (Figure 13). In fact, with the exception of the oscillating and programmed automatic monitors, the remaining automatic monitors had extinguishment times which were below or very close to the limiting curve. These results indicate that the automated monitors performed as well or better than a manual monitor in establishing control and extinguishment times in previous fire tests.

The application rates in these tests were quite similar and thus could not be used to verify the increased control/extinguishment time with increased application rate that McDaniel reports.<sup>2</sup> In the fire tests, the oscillating, servo-controlled, and remote controlled monitors were as much as 2-1/2 times slower than the manual monitor in establishing control and extinguishing the test fires (Table 6).

The foam concentrate required for the different automatic monitors which will provide the same capability as the manual monitor can be calculated. The ratio of the average extinguishment time for the automatic monitor in question to the average extinguishment time for the manual monitor is presented in Table 6 as the "Monitor Equalization Ratio." Thus the quantity of concentrate is equal to the product of this ratio, the foam application rate, the proportioning rate, the fire area, and the time that foam is required.

Another factor to consider in control and extinguishment times was the proportioning rate. The actual test proportioning rates ran from 3 percent to 5 percent and were checked by two previously described methods (Section 2.2). The difference in proportioning rates are attributed to industrial waste in the water and to the huge volume of foam from numerous tests which made its way back into the test water. These proportioning rates were plotted against the control times in Figure 14. This shows no apparent change in control time which can be attributed to proportioning rates. From this data, we conclude that any monitor system, whether automated or manual, should have a sufficient foam concentrate supply to provide for its particular proportioning rate.

TABLE 6

## CONTROL/EXTINGUISHMENT TIMES

EQUIPMENT	NUMBER OF TESTS	FLOW (gpm)	APPLICATION RATE (gpm/sq ft)	Average		EXTINGUISHMENT TIME MINUTES:SECONDS $\pm 24\%$	MONITOR EQUALIZATION RATIO
				CONTROL TIME MINUTES:SECONDS $\pm 33\%$			
Manual Monitor	3	340	.21	0:28		0:47	standard
Oscillating Monitor	3	335	.20	1:33		1:54	2.4
Servo-Controlled Monitor	3	365	.22	0:34		1:06	1.4
Remote Controlled (Electric, Pushbutton) Monitor	3	320	.19	0:46		1:24	1.8
Remote Controlled (Hydraulic, 3 Lever) Monitor	3	275	.17	1:06		1:37	2.1
Remote Controlled (Hydraulic, Joystick) Monitor	3	265	.16	0:31		1:03	1.3
Remote Controlled (Joystick) PAM Monitor	1	320	.19	0:46		1:10	1.5
Programmed Automatic Monitor*	3	275	.17	1:24		2:05	

\*Required use of joystick for control and extinguishment.

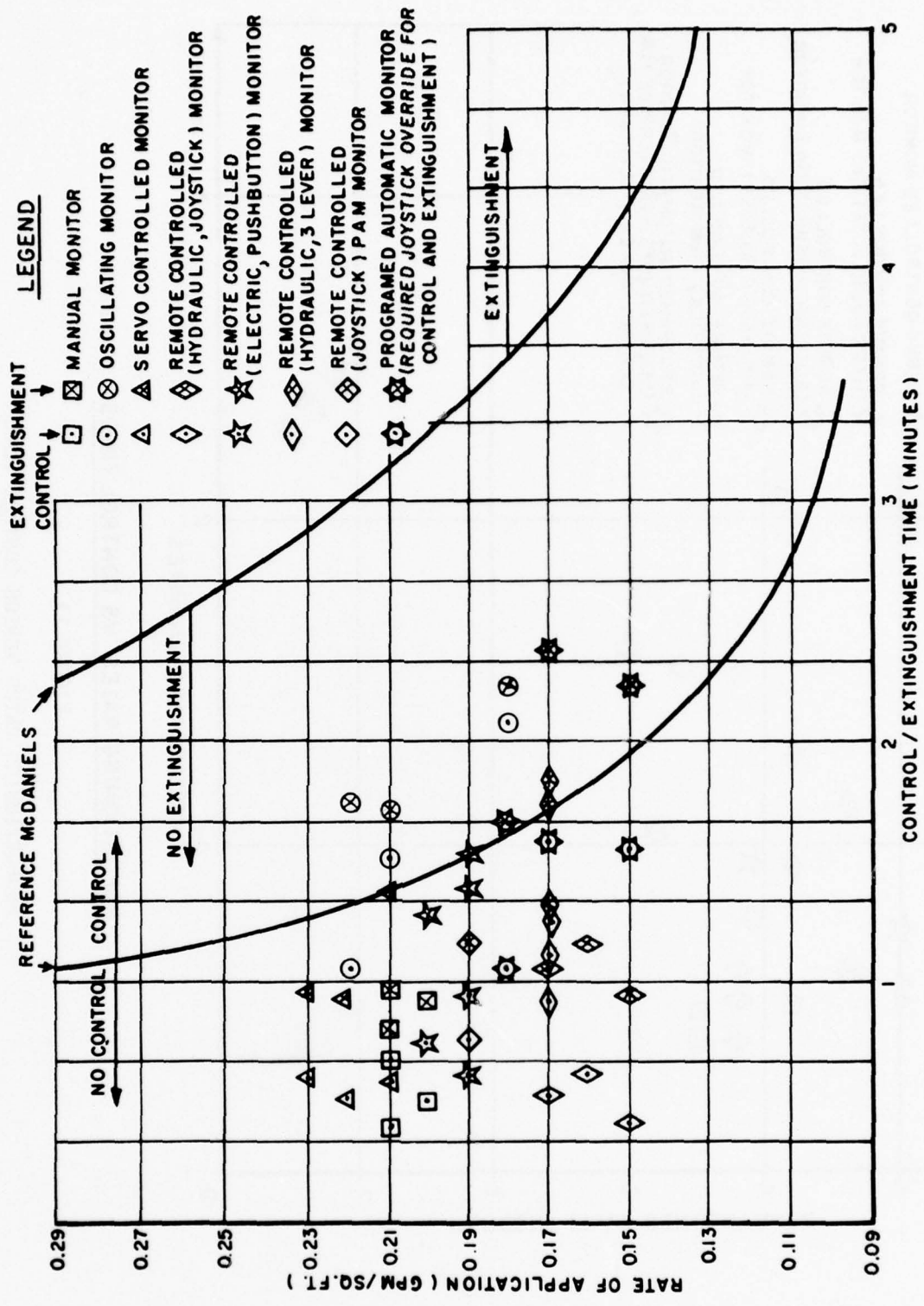

FIGURE 13

APPLICATION RATES VERSUS CONTROL/EXTINGUISHMENT TIMES



TABLE 7

## OPERATIONAL TIMES FOR MONITOR OPERATOR

TEST NUMBER	RUNNING DIFFERENT DISTANCES ACROSS A SHIP'S DECK		CLIMBING A 10' LADDER	OPENING A CONTROL VALVE	TOTAL AT 120 YARDS MINUTES:SECONDS	
	40 YARDS	80 YARDS				
1	18 seconds	37 seconds	1 minute 5 seconds	4.8 seconds	1 second	1:9.8
2	20 seconds	39 seconds	1 minute 3 seconds	4.1 seconds	1 second	1:8.1
3	23 seconds	41.5 seconds	1 minute 1 second	5.0 seconds	1 second	1:7.0

TABLE 8

## TIMES REQUIRED TO DON PROTECTIVE GEAR

GEAR	TEST NUMBER	TIME
Coveralls	1	13.2 seconds
	2	11.8 seconds
	3	12.8 seconds
Gloves	1	8.6 seconds
	2	6.4 seconds
	3	6.2 seconds
Gloves and Helmet-Faceshield	1	8.2 seconds
	2	8.6 seconds
	3	7.4 seconds
Bunker Coat, Gloves	1	21.8 seconds
	2	18.6 seconds
	3	19.4 seconds
Bunker Coat, Gloves, Helmet-Faceshield	1	22.2 seconds
	2	22.2 seconds
	3	19.0 seconds
Proximity Suit	1	1 minute 6 seconds
	2	52.6 seconds
	3	57.8 seconds

### 3.5 Time Study

The two time studies conducted involved timing the approach and initial operation of the monitor (Table 7) and the donning of various types of protective clothing (Table 8). On a large automated ship, it is unlikely that a crewman will be present at a monitor when a fire occurs. Consequently, some crew member will need to proceed a certain distance to the monitor. The test distances were traveled at the quickest pace, considered safe for traversing a tank vessel's main deck. The time study in Table 7 shows that when a monitor operator is required to travel 120 yards (a moderate length considering the size of modern tankers) to reach a monitor and make it operational, approximately one minute of time is consumed. The time study in Table 8 shows how little time is required to don protective gear. This time could make it possible to operate a manual monitor under fire conditions which would be intolerable without such protection. The short time spent donning protective gear could return high dividends in the firefighting operation.

### 3.6 Operational Design Factors

In justifying the approval of any automated monitor system, one of the principal considerations is which monitor can establish the quickest control and extinguishment time for a fire. Full-scale test fires realistically show which monitor performs that task most effectively. The next most important factor to be coupled with this is the mechanical reliability and durability of the monitor.

In the following sections the different monitors are discussed with regard to operational ease, reliability, versatility, serviceability, and equipment design. In order to be an effective and efficient firefighting tool, an automated monitor must meet specific performance requirements. For example, the operation of the controls must be apparent at a glance and require little operator dexterity. Time cannot be wasted in trying to read, understand, and manipulate complex controls. Other factors concerning the control panel include its location and orientation. The most effective and efficient monitor operation took place when the control panel was oriented such that it positioned the operator above and behind the monitor. This panel orientation created a situation where automated control movements were most similar to actual physical movements. Simplicity in control design and manipulation must be a consideration for approval of automated systems.

A monitor system must be reliable. The unit must function regardless of inconsistent use or exposure to adverse weather and/or fire conditions. Endurance tests should be conducted on the automated systems to check reliability. Should the automatics of a system fail, all the advantages for having a remote control system disappear. If the unit does not have a backup manual mode, the entire system is useless. Only the servo-controlled and oscillating monitors had a backup manual mode. The one on the servo-controlled unit failed. If automated monitors are to be approved, a workable, failproof backup manual mode must be incorporated into the system.

All monitor parts exposed to marine conditions should be subjected to exposure tests in a marine atmosphere to ensure reliability of operation. All construction should be of corrosive-resistant materials. Since the automated monitors will probably be positioned close to potential fire hazard areas, all parts should be constructed of heat-resistant materials. Hydraulic hoses and electric cables should be coated with fire-resistant material and/or be placed in protective conduit. The automated monitor must be easily serviced by ship's personnel.

The test monitors had two different drive mechanisms, oil piston and worm gear drives. The piston drive gave quicker and more jerky motions while the worm gear drive was more methodical and deliberate in directing the monitor. The worm gear drive was preferred by the majority of the operators even though it demanded slightly more skill.

#### 3.6.1 Manual Monitor

The manual test monitor (Figure 15) was a Coast Guard-approved unit (Approval Number 162.033/14/0). Little physical effort was required on the part of the operator to direct the monitor discharge. A control handle was used to direct the monitor at its target. No prior training or instruction was necessary. The changeover from fog pattern to straight stream was accomplished by twisting the control handle. This action opened or closed an extension over the discharge end of the shaper tube. The monitor, control handle, and the discharge tube were steel. There were no installation difficulties requiring the use of specialized tools or formal training.

#### 3.6.2 Oscillating Monitor

The oscillating monitor was a complete, self-enclosed unit (Figure 16). It required no electrical or hydraulic power supplies. Once installed, the oscillating monitor required several internal adjustments to cover the particular fire hazard area. The monitor was adjusted for its fixed angle of depression or elevation, its arc of oscillation and its speed of oscillation. The controls for adjusting (Figure 17) were contained in the main body located at the base of the monitor. The necessary requirements were determined and the adjustments were made according to the instruction manual. No specialized tools or trained personnel were necessary. The continuous monitor oscillation is accomplished by diverting a small amount of the incoming fire-fighting solution. The oscillation drive takes less than 1 gpm.

The oscillating monitor had two modes, an oscillating mode, and a manual override mode. Pulling out a small 3-inch removable detent pin on the monitor handle allowed the monitor to become manually operated in elevation or depression. The next step required the disengagement of the oscillating drive gears by pulling a 4-inch manual disengagement handle located at the bottom left-hand side of the monitor control panel. These two actions

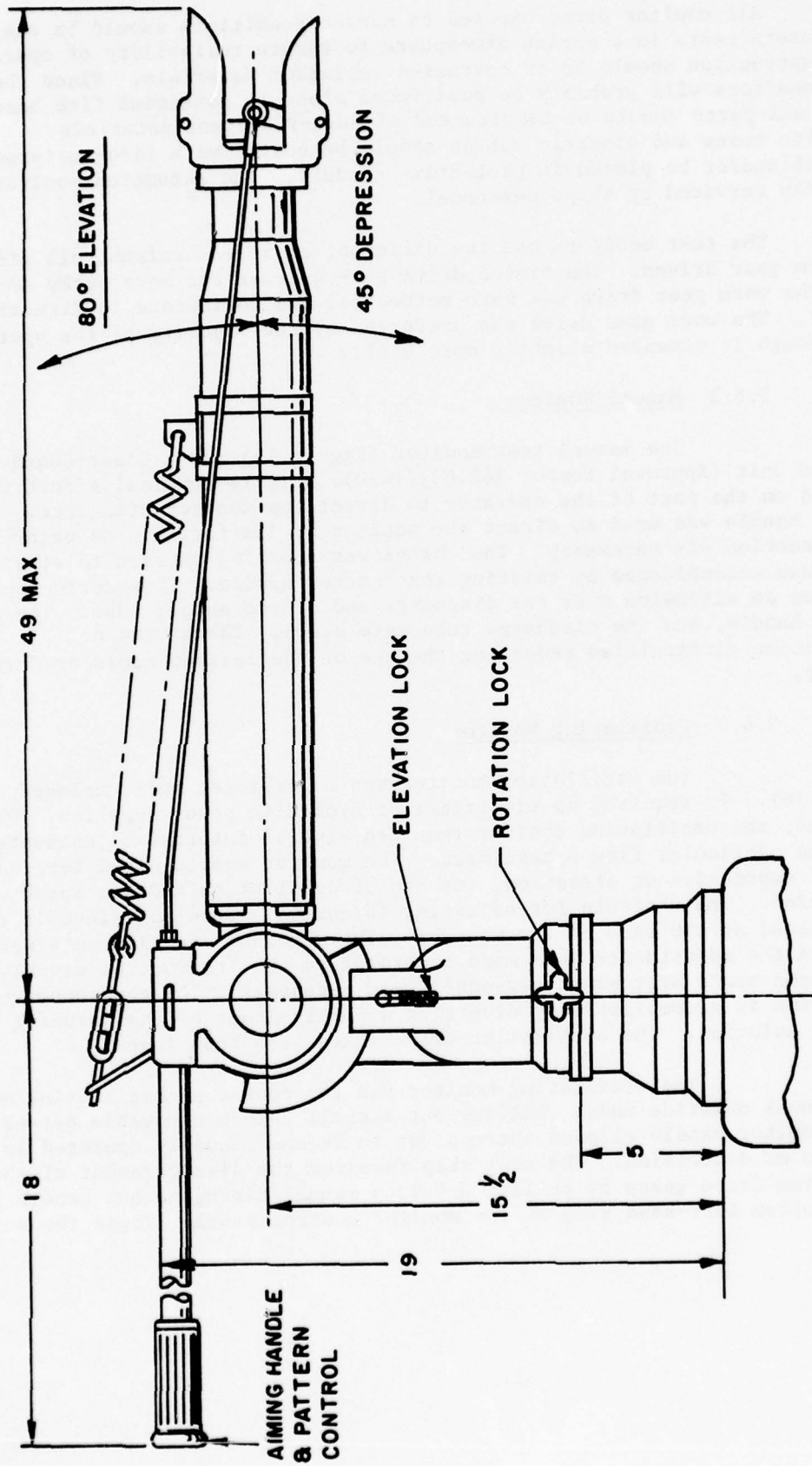

FIGURE 15

COAST GUARD-APPROVED MANUAL MONITOR

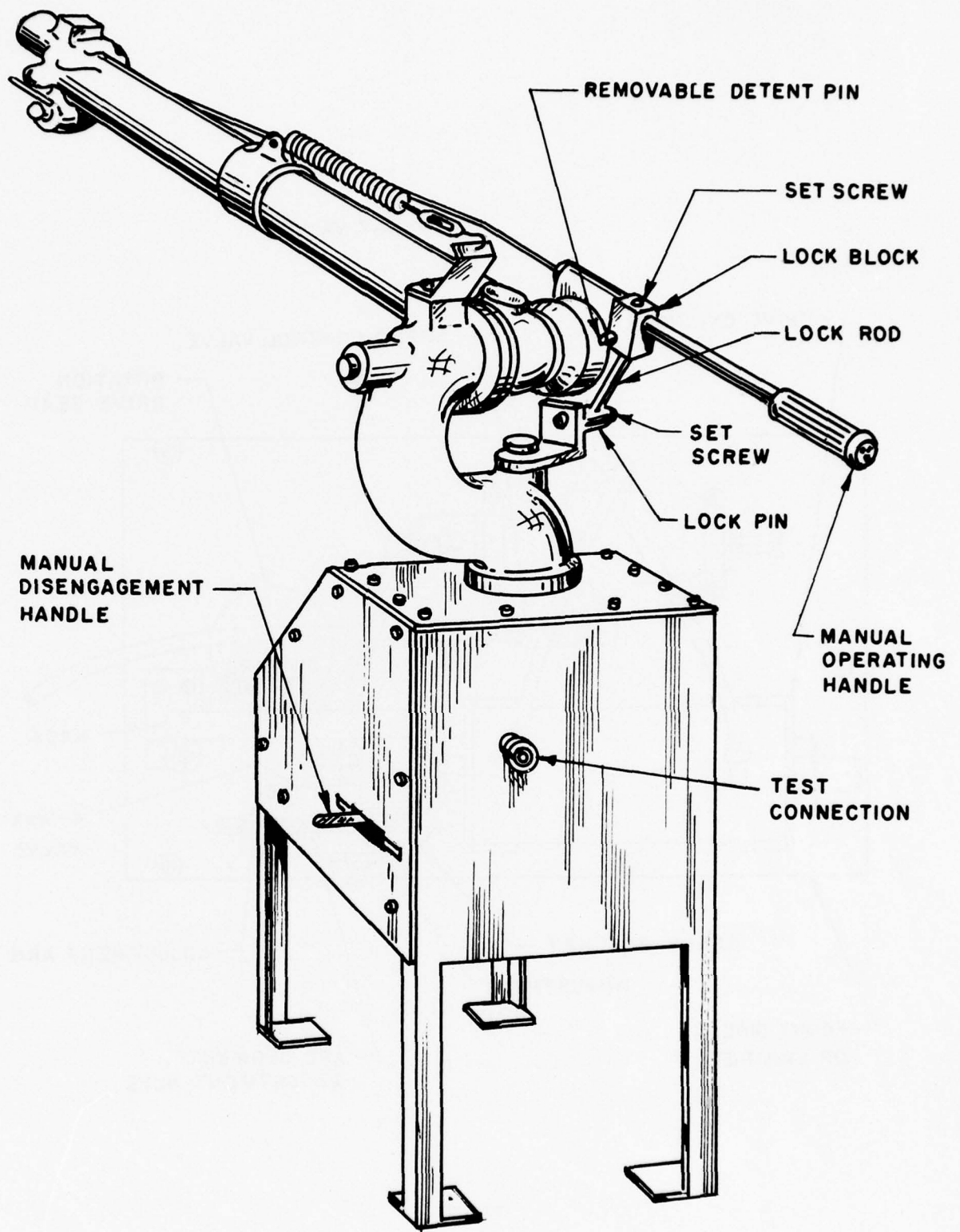

FIGURE 16

OSCILLATING MONITOR

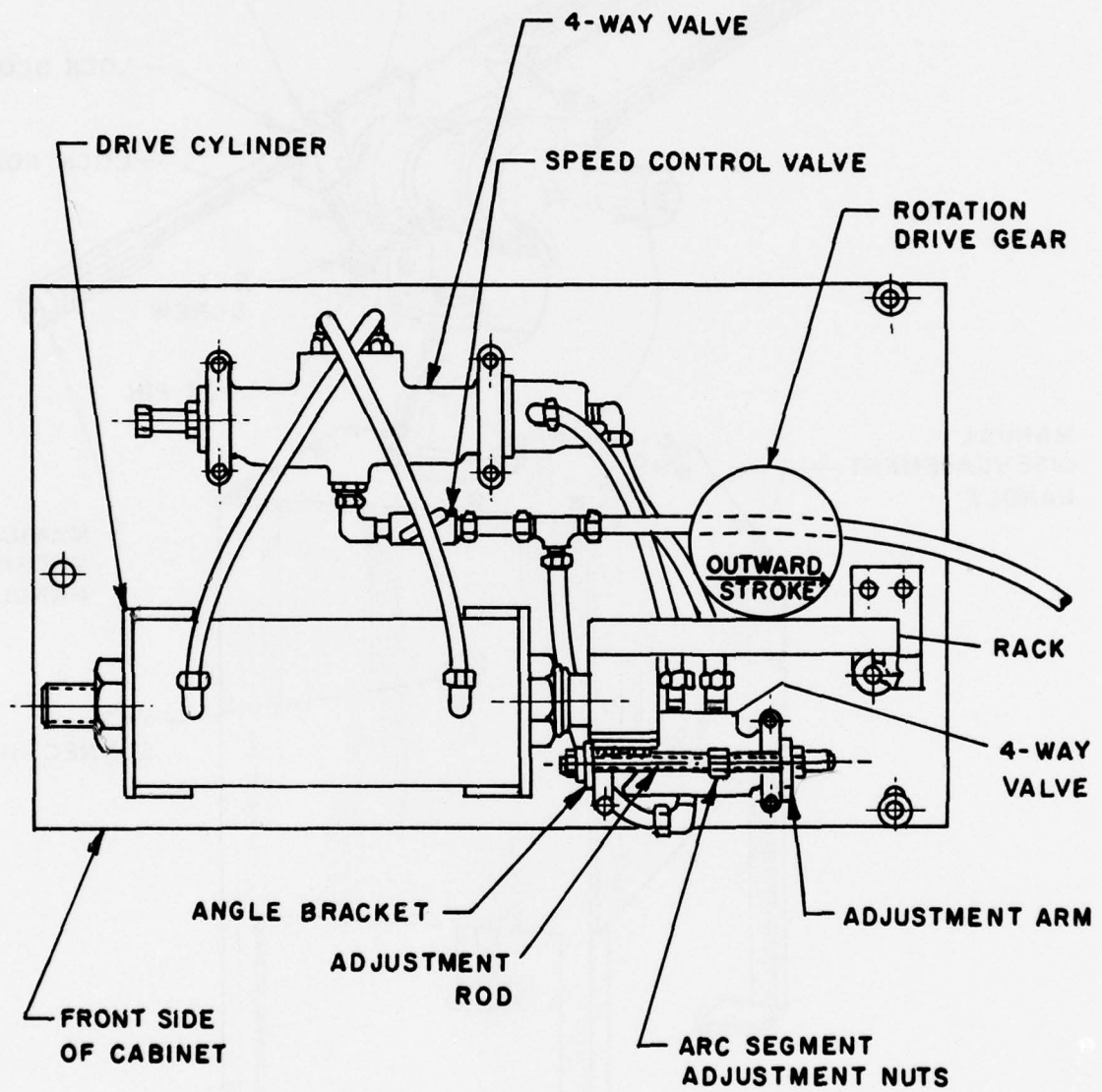

FIGURE 17  
 OSCILLATING MONITOR INTERNAL CONTROLS

gave manual control to the operator. One problem with the detent pin was the difficulty involved in pulling the pin out of the lock block. The steel ring attached to the pin was too small to get a gloved finger in it. When jerked quite suddenly, this ring would straighten out and break. The detent pin, unless pulled exactly horizontally from its lock block, would jam or bind against the sides of the lock rod inside the lock block. This pin would then wedge itself in such a manner that the tighter one pulled, the more firmly it wedged itself.

One of the problems experienced with the oscillating monitor was the slack of  $10^\circ$  found in adjusting its angle of depression or elevation. Once the monitor was preset for a specific angle of depression and the extinguishing solution was applied, the monitor would randomly raise or lower itself to any point within this  $10^\circ$ . This becomes a problem when the monitor is pointed at a critical fire hazard. The monitor had the capability to produce either a fog pattern or a straight stream pattern. This was accomplished manually by twisting the handle of the monitor control.

The control panel requires minor internal changes to be compatible with shipboard use. All plastic tubing and hoses need changing to metal for protection against heat exposure. Gears and metal parts which mesh together or slide across each other need to be treated for prevention of galvanic corrosion or designed against corrosion buildup.

### 3.6.3 Servo-Controlled Monitor

The servo-controlled monitor consisted of the monitor, its four discharge barrels permitting different combinations of foam or water application, a hydraulic power supply, the monitor's base, and the monitor controls extending beneath the base (Figure 18). This unit had hydraulically powered controls. Pistons were employed to move the monitor to control demands. The monitor was placed atop a 7-foot stand so that the operator could stand beneath it for convenient operation. It could be easily directed by one hand without undue strain or exertion. The control levers located underneath the monitor baseplate were numerous and technically worded in describing control functions (Figure 18).

The monitor was capable of a variety of water or foam solution discharges. Added to this was the selection of a fog or straight stream pattern; hence, the control panel became too complex to operate unless the operator had previous training on the unit or followed step-by-step written instructions which required at least 1/2 hour for control familiarization. The control complexity of this unit could be simplified by reducing these capabilities to only those need aboard ship.

The control panel had one main lever used to direct the discharge tube either left, right, up, or down. Other levers controlled selection of the proper barrel. Adjusting screws were used to speed up or

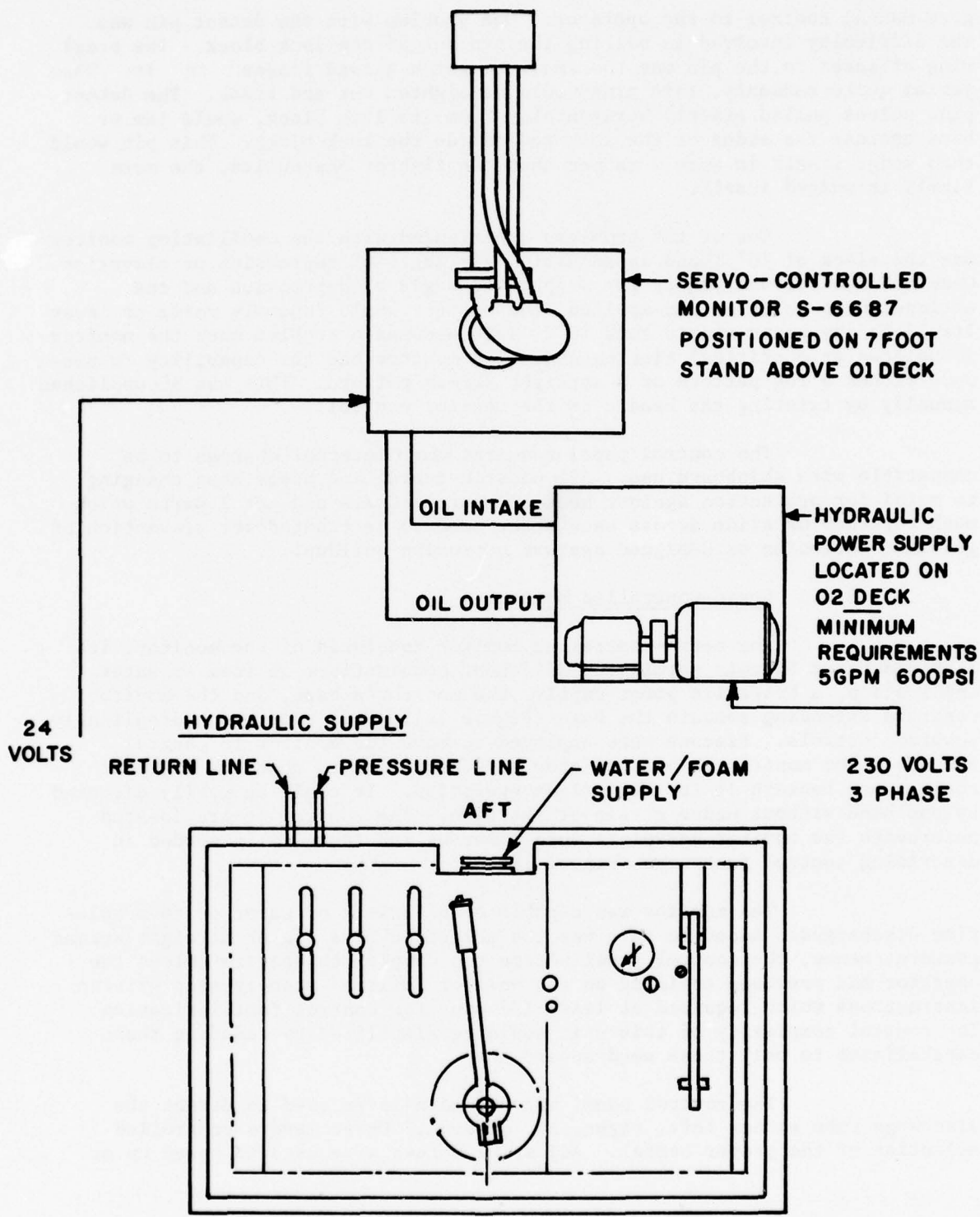

FIGURE 18

SERVO-CONTROLLED MONITOR

slow down the monitor motion by regulating the hydraulic oil flow. The monitor was designed to function in the servo-control mode and in a manual mode. During the tests, the manual mode could not be tested due to failure of the mechanism permitting hydraulic oil to bypass the turret.

The turret did have a slight time lag in responding to control movements. This lag was less than one second but evident to each operator. This slight delay, combined with rapid turret movements, created a sluggishness in the response of the monitor. As the foam solution passed from the monitor into the discharge tube, quantities of the liquid failed to enter the tube collector and were sprayed over both the monitor and its operator.

The monitor was constructed of steel with the discharge tubes made of aluminum. Numerous micro-switches and electrical circuits were employed in the monitors control panel. Those items would be vulnerable to corrosion. The monitor itself required no specialized tools for installation. Should there be a malfunction in the controls, it is questionable whether shipboard personnel could solve the problem. Another problem area would be the protection of the electrical line and hydraulic hoses supplying the monitor.

#### 3.6.4 Remote Controlled Monitors

##### 3.6.4.1 Remote Controlled (Electric, Pushbutton Monitor)

The substitution of the REC-3 special pushbutton control panel changed the RCM-4S system to an electric remotely controlled monitor (Figure 19). This pushbutton panel connected directly to the EVO-1 panel. It consisted of six buttons. Each controlled only one function. The four movements were up, down, left, and right, but the monitor could be moved diagonally by using two control buttons at the same time. Straight stream and fog pattern buttons were also included.

Operation of the pushbutton REC-3 panel was self-explanatory at a glance. No previous training or extensive written instructions were necessary for its effective use. The panel could be operated effectively with one or two hands. This monitor was limited to remotely controlled operation as it was not equipped with a manual override control mode.

The REC-3 panel was constructed of 16-gauge steel. Corrosion problems inside the panel would not appear to be a severe problem because of the solid-type construction. The panel was easily connected to the existing RCM-4S system by simple connecting devices. No special tools or unique training were needed for its installation.

##### 3.6.4.2 Remote Controlled (Hydraulic, 3 Lever) Monitor

This remote controlled monitor consisted of a control panel box (RHC-1), the remote controlled monitor (RCM-4S) with a PC-50 discharge tube, and a hydraulic oil power pack (HPS-1-4-10) (Figure 20). The control panel consisted of a run light (green colored to indicate that the hydraulic supply motor was operating), a hydraulic motor start button, three levers for controlling

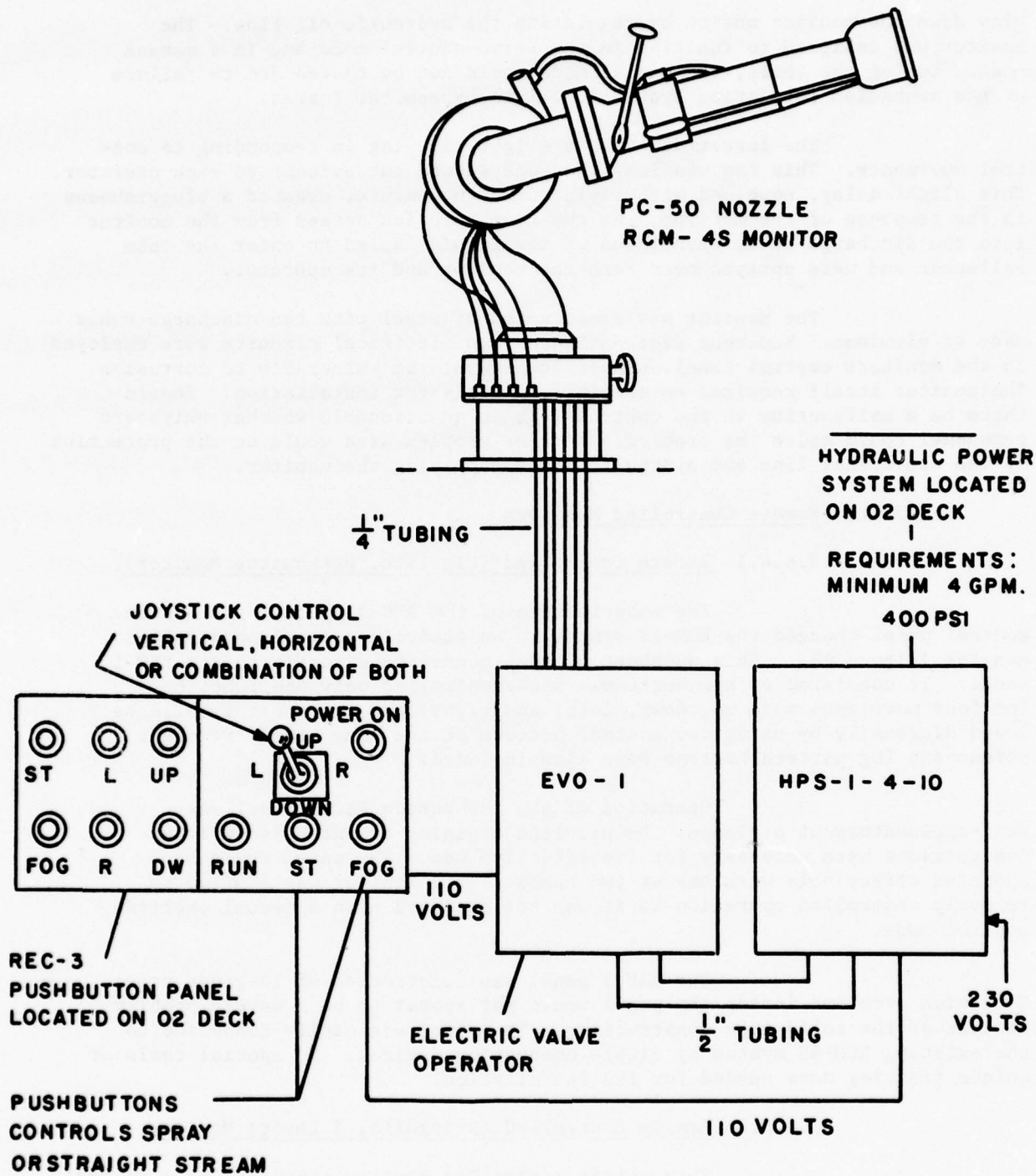

FIGURE 19

REMOTE CONTROLLED (ELECTRIC, PUSHBUTTON) MONITOR

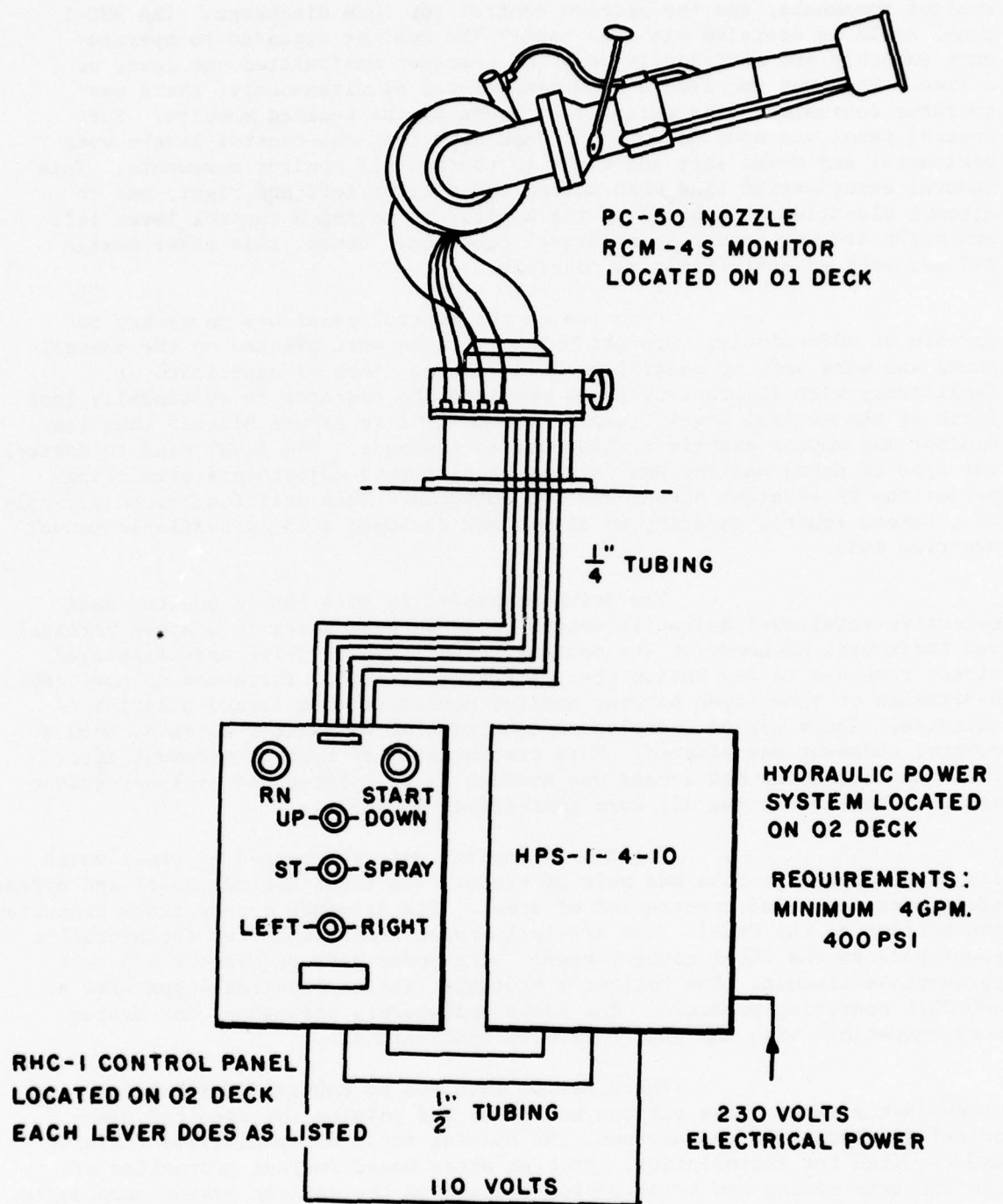

FIGURE 20

REMOTE CONTROLLED (HYDRAULIC, THREE LEVER) MONITOR

monitor movements, and the pattern control for foam discharge. The RHC-1 panel could be operated with one hand. The monitor appeared to operate more smoothly and efficiently when the operator manipulated one lever at a time. Whenever two levers were manipulated simultaneously, there was operator confusion as to which lever produced the desired results. The control panel was mounted on a bulkhead such that the control levers were horizontal and moved left and right to control all monitor movements. This control setup worked fine when moving the monitor left and right; but to attempt elevating or depressing the monitor by moving a control lever left and right did not appear as a natural function. Hence, this panel design did not work as efficiently as possible.

Practice on the control panel was necessary to operate it effectively. Operation instructions were printed on the control panel and were easy to understand at a glance. Lack of experience or familiarity with the control panel required the operator to continually look first at the control panel, then at the monitor to assure himself that the monitor was moving exactly to his desired commands. The lever used to control the type of spray pattern was capable of different adjustments permitting variations of straight stream and fog patterns. This unit functioned strictly in a remote control capacity as it was not equipped with an available manual override mode.

The drive mechanism in this RCM-4S monitor used selective rotational hydraulic motors to drive worm gears to achieve vertical and horizontal movement of the monitor. This type of drive unit displayed direct response to any action the operator initiated. There was no noticeable hesitation or time lapse between monitor movements when issued a series of commands. There was no overplay or continuation of monitor movement once a control movement was stopped. This continuation of monitor movement after the control command has ceased was evident in all piston and cylinder-driven monitors but not in the oil worm gear-driven monitors.

The RCM-4S monitor was constructed of steel while its PC-50 discharge tube was made of brass. The RHC-1 control panel and hydraulic power pack were also constructed of steel. Six 1/4-inch copper tubes connected the monitor to the RHC-1. Two 1/2-inch copper lines connected the hydraulic power pack to the RHC-1 control panel. The power pack required a 230-volt three-phase circuit. The monitor's hydraulic system required 4 gpm flow at 400 PSIG operating pressure. The seals and gaskets throughout the system were compatible with any generally used hydraulic oil.

Installation involved no unusual difficulties other than arranging the various equipment and joining the required electrical and hydraulic connections. No special tools or specialized training was required for installation. Problem areas would include protection of the electric wiring and metal tubing connecting the various system components.

#### 3.6.4.3 Remote Controlled (Hydraulic, Joystick) Monitor

The remote controlled (hydraulic, joystick) monitor consisted of the joystick control panel, the monitor, a discharge tube, a hydraulic power supply, hydraulic hoses, and the necessary electrical wiring (Figure 21). The joystick panel consisted of a small metal box with a single lever and two pushbuttons. If the lever was pushed to the left, the monitor turned left, when pushed to the right, the monitor turned to the right. When the lever was directed forward, the monitor depressed toward the deck, when the lever was pulled back, the monitor elevated. The joystick could effectively be operated with either hand.

One of the two pushbuttons caused the monitor to discharge a fog pattern and the other created a straight stream pattern. The discharge tube used on the monitor did not have the mechanical capability of switching back and forth from straight stream to fog pattern by remote control means, although the monitor and the control panel were capable of handling this function. A lever was provided on the discharge tube to change the pattern. The control panel had explicit operating instructions. The instructions were self-explanatory and easy to understand. No previous training or instruction was found necessary for the operator to control the monitor with a reasonable degree of effectiveness.

The control panel for the monitor was located on the 02 deck and positioned close to the port side of the ship. This placed the control operator above, behind, and to the left of the monitor spray. This panel location created a situation where the maneuverability target was partially obscured from the operator's view by the discharge stream. The long maneuverability times for this unit occurred not because of mechanical problems but because the operators directed the solution discharge at what they thought was the target but in reality was the side of the target. It is normal to expect a forward movement of the control lever to cause an action to go forward or down. If this remote control panel is mounted vertically on a bulkhead, then the action of pushing the joystick forward which is then up causes the monitor to go down. When the panel was mounted vertically on a bulkhead the resultant control confusion caused us to remount the panel on a horizontal surface. We mounted the control panel perpendicular to the ship's length, again the operator experienced an orientation problem. The remote controlled monitor tested had one control mode, that of being remotely controlled by the joystick. Should this unit fail to function in the remote control mode, there would be no means for converting it to a manual mode of operation.

The monitor itself was made of steel while the discharge tube was constructed of aluminum. Two stainless steel pistons enclosed in cylinders were employed on the monitor to move it either left or right and up or down. Hydraulic oil pressure applied to either end

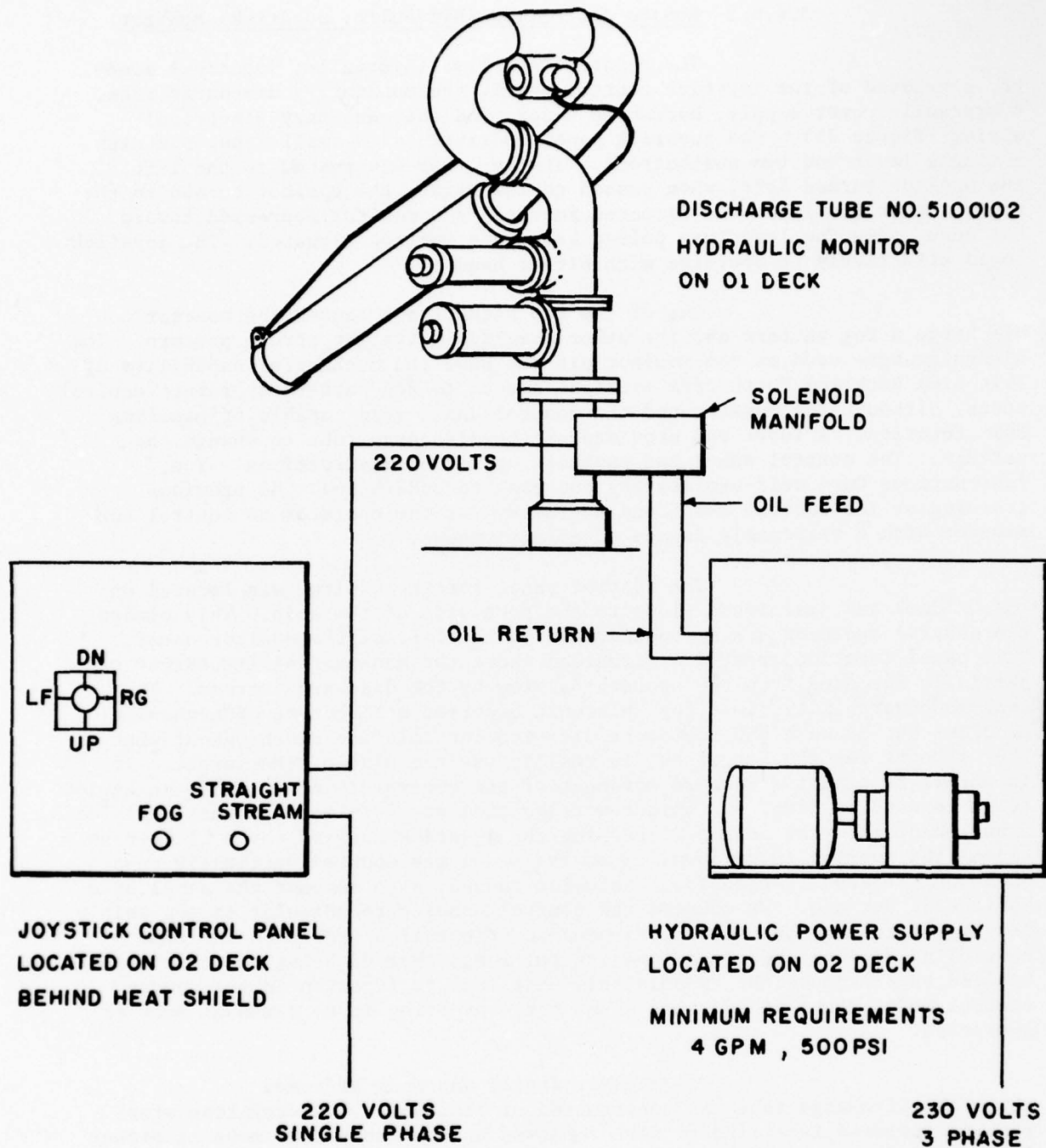

FIGURE 21

REMOTE CONTROLLED (HYDRAULIC, JOYSTICK) MONITOR

of a piston allowed it to direct one of two possible monitor movements. The pistons were attached to the monitor and formed a hydraulic circuit which employed a constant delivery pump to move the pistons at a variable speed corresponding to a fraction of the displacement of the pump. The rate of motion of the piston was controlled by the flow rate of hydraulic liquid into the cylinder housing the piston. Installation of the monitor required connecting a 220-volt, single-phase power source to the control panel. From the control panel 220 volts were directed to a set of six solenoids attached to the monitor base. The solenoids controlled the on/off motion of hydraulic oil in the piston cylinders. Two main oil lines leading from a variable flow and pressure hydraulic pump fed and relieved oil to a dividing manifold at the base of the monitor. This manifold controlled by the solenoids was used to divide and channel oil to the various pistons. Minimum flow and pressure for monitor operation was 4 gpm and 500 PSIG. A hydraulic fluid (MIL-H-5606) capable of being used in all tested monitors was used.

Installation presented no unusual difficulty once we had the necessary electrical wiring, copper tubing, hydraulic hoses, and hose attachments. No special tools or trained personnel were required for installation. During the testing, the monitor experienced failure of two solenoids at different times. As a result of solenoid failure, the monitor lost the control motion to the right. Corrective measures required shutting down the monitor system and replacing the jammed solenoid. This required approximately 45 minutes.

The piston-controlled movement of the monitor had a time lag or overplay between every control command. The monitor when moved in one direction and then another, experienced a slight hesitancy between each control command. This delay is extremely short (i.e., less than one second), but when directing a discharge stream at a target, several cyclic corrections are required to overcome this delay and to keep the solution discharge on target. The malfunction of the solenoids to operate was the biggest reliability problem experienced. Other problem areas would include the protection and placement of electric lines and hydraulic hoses away from fire and harmful conditions.

### 3.6.5 Programmed Automatic Monitor

The PAM (Programmed Automatic Monitor) System consisted of a RCM-4S monitor mounted with two radial ultraviolet locator detectors, a PC-50 discharge tube, one sector ultraviolet detector, an EVO-1 panel, and a PAM override control console (Figure 22). This unit was designed to automatically protect the hazard area. The foam production period was divided into two time segments. During the first segment the sector detector detected the fire and pointed the monitor at the fire's edge. The two radial detectors then directed the monitor at the lower right edge of the fire for a preset time. At the end of this segment, the monitor began an oscillating motion through a solid angle of 0.25 steradians while sweeping from the point of initial attack into and through the lower portion of the fire pens. During the tests, the monitor continued its sweep through the lower portion of the

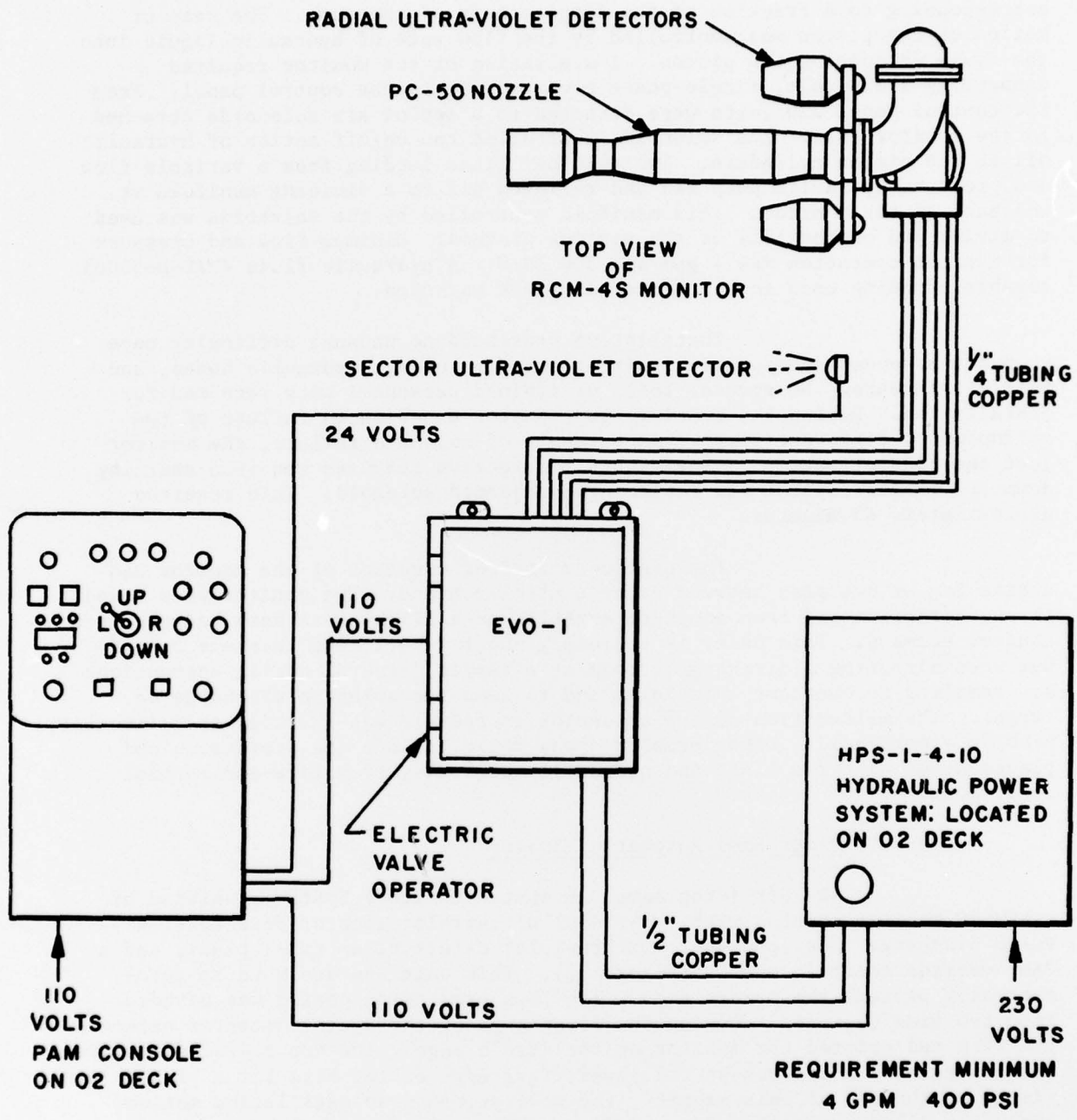

FIGURE 22  
PROGRAMMED AUTOMATIC MONITOR

fire and to the left even though it had gone past the fire pens. It continued until the monitor reached its horizontal arc limit (Figure 23). There, it locked into position, still ejecting foam. The sector radial detector failed to detect the still existing fire and redirect the monitor back into the test fire. Only the lower 15 feet of the 55.5-foot long test fire had been touched by the foam and even that area was not extinguished. Once it was decided that the sector detector would not redirect the monitor back toward the fire, the remote control joystick on the PAM console was employed to extinguish the fire. This action was repeated identically by the PAM system on all three of its test fires despite adjustments to the system by factory representatives.

The PAM console had a joystick control capable of overriding the system's automatic feature should any malfunction occur. The joystick was easily operated by one hand. The control instructions printed on the console were easy to read, understand, and follow. No previous training or unique skills were required to effectively control the monitor. The control console was located on the 02 deck behind and to the port side of the monitor. Manual operation was not a feature of this monitor. Fog and straight stream patterns could be regulated remotely.

The initial installation was performed quickly since all the system components were designed to connect to each other with simple plug attachments. The initial adjustments of the ultraviolet detectors required the assistance of trained personnel. The sensitivity adjustment of the ultraviolet detectors required forehand knowledge of the possible fire intensity to be radiated from the fire hazard. The PAM console consisted of numerous electrical and electronic components and circuits. This panel would require complete protection from the environment to prevent dangerous corrosion to critical internal circuitry. Any malfunction problems in the PAM console would probably require trained personnel to repair it due to its complexity.

#### 4.0 CONCLUSIONS AND OBSERVATIONS

The automated monitors, with the exception of the programmed automatic monitor, were effective in controlling and extinguishing shipboard deck fires. They were slightly slower than the manual monitor in all test times, but their effectiveness was increased by their capability of functioning under fire conditions which rendered the manual monitor impossible to approach and operate. The detectors and circuitry of the programmed automatic monitor could not direct the monitor to either control or extinguish a deck fire. The manual monitor did permit quicker and more precise control than the other monitors, but effective firefighting with monitors did not require the discharge tube to be aimed with precision since the discharge of several hundred gallons per minute initially covered a large target area. Precise control and split-second handling are only partial requirements for effective monitor operation on tanker deck fires. Other important requirements based on test performance, desired objectives and operator requirements show the most effective automated monitor to be a remote controlled (hydraulic,

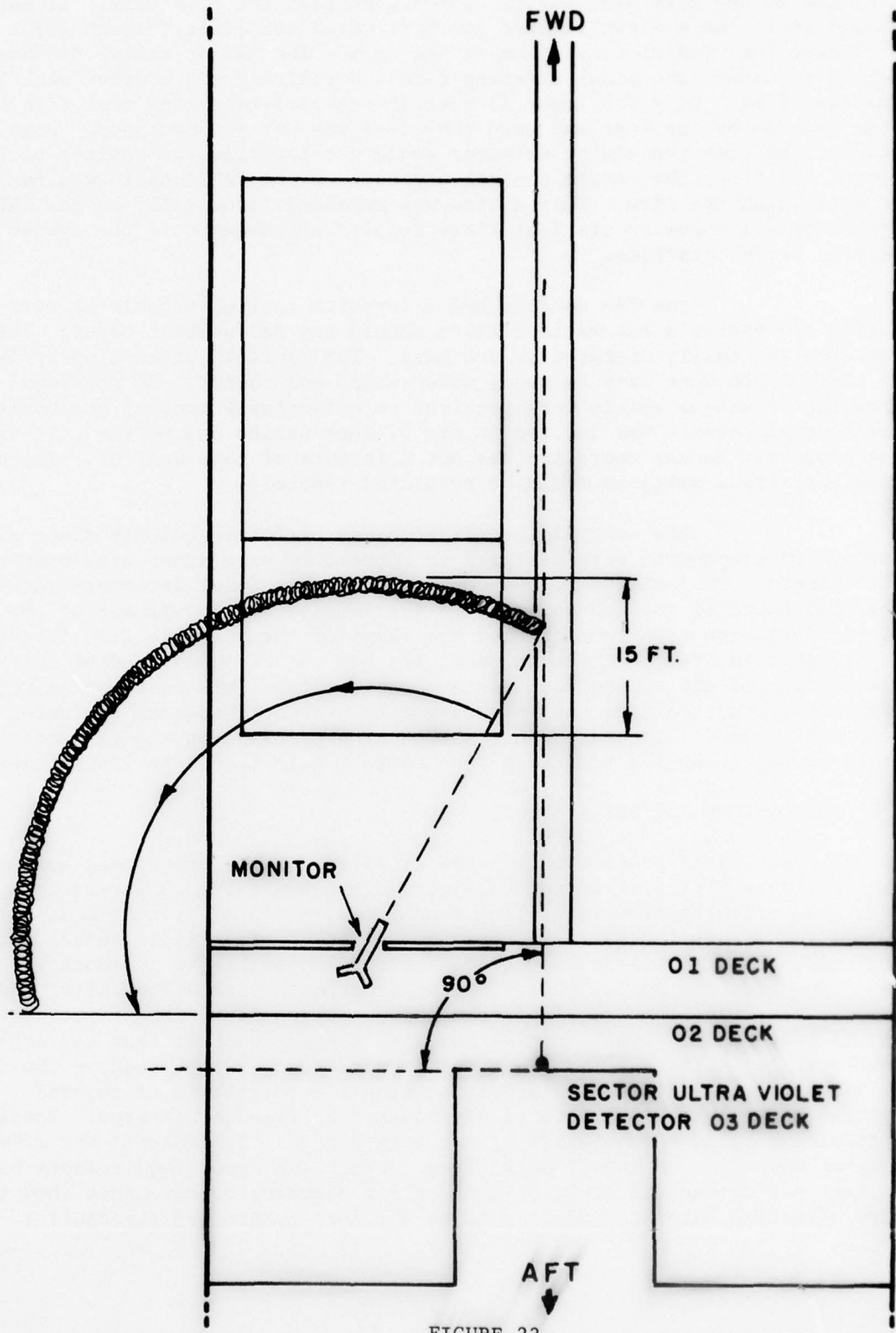

FIGURE 23

PAM, ULTRAVIOLET DETECTOR AND OSCILLATING COVERAGE

joystick) employing a worm gear drive mechanism. The joystick control panel permitted the most coordinated operator control while the worm gear drive mechanism permitted regimented, methodical monitor movements.

Foam wastage in a non-fire situation was best minimized by a regimented, methodical control mode which permitted very little overplay. Control modes producing quicker and more liberal monitor motions permitted more foam wastage.

Control and extinguishment times in fire situations are best minimized by automated control modes which permit quick and liberal monitor movements. Even the foam discharged outside the fire area due to monitor overplay is not wasted but instrumental in preventing fire spread and in creating a deep foam layer to spread across the fire surface. Based on the observed control and extinguishment times of the automated monitors, the monitors most competitive to the manual monitor were the remote controlled (hydraulic, joystick) and the servo-controlled monitors. The slightly slower remote controlled (hydraulic, joystick) monitor using the oil worm gear drive mechanism was preferred by the majority of the operators over the two monitors employing slightly quicker oil piston-drive mechanisms.

Automated monitors can be activated more rapidly than manual monitors. By positioning the control panel inside the ship's bridge, it is possible to energize the monitor almost immediately. Whereas on existent large tanker vessels, up to one minute may be needed by a monitor operator in reaching a distant monitor.

Protective firefighting clothing is recommended for manual monitor operators. The time required for a monitor operator to don protective firefighting clothing is short enough to make it advantageous to do so.

Most of the automated monitors demonstrated poor durability and reliability of functioning through short periods of testing. The foremost problem of the automated monitors was not their ability to effectively and efficiently extinguish a fire but with the reliability of the unit to function after (1) extended periods of intermittent use, (2) corrosive effects of the environment on equipment, and (3) internal component failure. Most of the units tested experienced some minor component failure. Although not critical in this test series, some of these failures could have been crucial if the monitor had been needed immediately. Thus a manual override mode is a necessity on all automated monitors. Since it is probable that automated monitors would be positioned extremely close to the fire hazard, it is essential that all heat-susceptible parts be replaced or protected, all metal components need to be corrosion-resistant, hydraulic hoses and electric lines be protected, and serviceability of the units be feasible by shipboard personnel.

The physical requirements for effective usage of the automated monitors were less demanding than for a manual monitor. Any person physically capable of handling a manual monitor would be more than capable of operating the automated monitors. Depending on control complexity, some monitors required a study before usage while others did not. This should be minimized and instruction should be clear and concise.

## REFERENCES

1. McDaniel, Dale. Report of Deck Foam Fire Extinguishing Test Aboard M/V RHODE ISLAND. Department of Transportation and U. S. Coast Guard, June 1972.
2. McDaniel, Dale. Fire Extinguishing Effectiveness of A Synthetic Surfactant Foam. Department of Transportation and U. S. Coast Guard, August 1974.
3. Rules and Regulations for Tank Vessels. Subchapter D (Title 46, C.F.R., Parts 30 to 40, Inclusive), CG-129.
4. Navigation and Vessel Inspection Circular 6-72. Department of Transportation, U. S. Coast Guard.
5. National Fire Protection Association. Fire Protection Handbook. Thirteenth Edition, 1969.
6. United States Coast Guard, Department of Transportation. Fire Fighting Manual for Tank Vessels, CG-329, 1 January 1974.
7. Fu, Tim T. "Heat Radiation From Fires of Aviation Fuels," FIRE TECHNOLOGY, Vol. 10, No. 1, February 1974.
8. National Fire Codes, Volume 1, 1975. Standard for Foam Extinguishing Systems, NFPA No. 11, 1974.
9. National Fire Codes, Volume 10, 1975. Standard for Evaluating Foam Fire Fighting Equipment on Aircraft Rescue and Fire Fighting Vehicles, NFPA No. 412, 1974.
10. Casey, James F. The Fire Chief's Handbook. Dun Donnelley Publishing Corporation, New York, NY. Third Edition, 1974.
11. Beene, David. E., Jr., Fire Endurance of Aluminum and Steel Hatch Covers. Department of Transportation, U.S. Coast Guard, to be published 1977.

APPENDIX A

FOAM QUALITY TESTS

Foam quality was checked by procedures included in NFPA 412. Foam patterns were measured similar to procedures in NFPA 412 but modified for use on a tank vessel.

## Appendix A — Suggested Test Methods and Calculations

### A-100. GENERAL

#### A-110. Purpose of Appendix

A-111. The following field tests for foam agent capabilities on aircraft rescue and fire fighting vehicles are given in order that standardization may be achieved in testing procedures.

A-112. The differences in the test equipment and the procedures followed to evaluate the characteristics of foams generated when using protein-type (including fluoroprotein) foam-liquid concentrates as distinct from the characteristics of foams generated when using aqueous-film-forming-foam (AFFF) concentrates should be noted and utilized accordingly.

### A-120. Organization of Appendix

A-121. The test methods given are presented in the order of their mention in this Standard (see Article 400).

### A-200. Ground Pattern and Foam Physical Property Tests

#### A-210. Turret Ground Pattern Test

A-211. Prior to the start of the tests the water tank shall be filled, the foam concentrate tank filled with the type of material to be used in actual emergencies (protein, fluoroprotein, or AFFF type), and the proportioner set for normal fire fighting operation. In order to standardize the results, the water and concentrate temperatures should lie within the 60-80° F range; if this is not possible, see A-500 in this Appendix for temperature correction factors when using protein-type foam liquid concentrates. (Similar correction factors have not been established when using AFFF type concentrates.)

A-212. These tests are designed to show the effective fire extinguishing patterns produced by foam falling on a ground spill and to determine the maximum range attainable by the turret stream under test. In order to establish a common condition for defining these patterns, the tests should be conducted under no-wind conditions, or as close to this condition as possible. The turret nozzle should be tilted upward to an angle of 30° with the horizontal. (This angle provides maximum reach for the pattern.) Foam shall be generated onto a paved surface for a period of exactly 30 seconds for each desired nozzle setting, such as straight-stream, dispersed or spray stream, and mid-stream. Immediately after foam discharge has stopped, markers shall be placed around the outside perimeter of the foam pattern as it fell on the ground. Fluid foams will tend to flow

outward on standing and distort the original pattern. For purposes of defining the edge of the pattern any foam less than 1/2 inch in depth should be disregarded and considered ineffective. After distances from the turret to the markers and distance between markers have been plotted on cross-section paper, the vertical axis should show the reach and the horizontal axis the pattern width for each nozzle setting. In the event that greater accuracy is desired, a grid of stakes on 3-ft. centers is preplaced over the area to be foamed. Foam depth measurements are made at each stake and then plotted on a scaled grid laid out on cross section paper. Points of equal depth are joined together in the manner of a contour map. This plot will indicate the uniformness of foam distribution from the nozzle. (See Figures in Article A-300 of this Appendix as typical pattern plots.)

#### A-220. Foam Sampling

A-221. The treatment of a foam after it has left the turret or nozzle has an important bearing on its physical properties. It is, therefore, extremely important that the foam samples taken for analysis represent as nearly as possible the foam reaching the burning surface in normal fire fighting procedure. Foam for analysis from a straight stream should be collected from the center of the ground pattern formed with the nozzle aimed for maximum reach. Similarly, for dispersed stream application foam should be sampled from the center of the resulting ground pattern area with the nozzle set for dispersed stream operation. In order to standardize and facilitate the collecting of foam samples, special collectors are used as shown in Figures 1A and B.

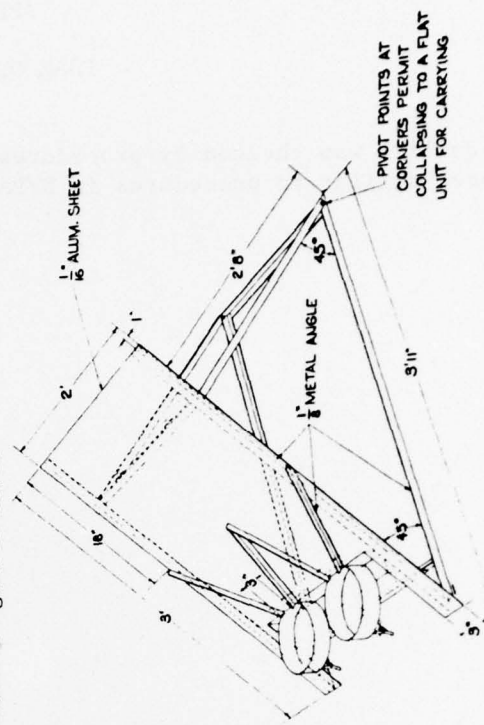

Figure 1A  
Protein Foam Collector

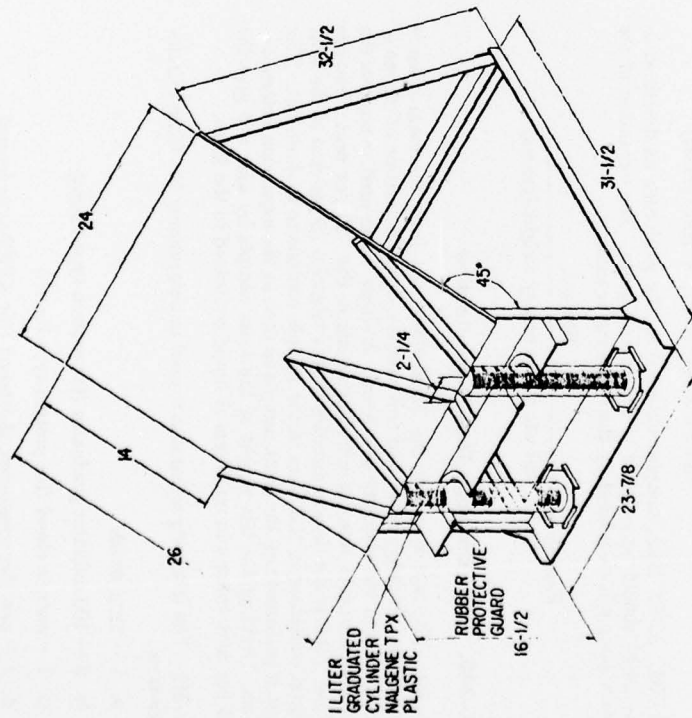

Figure 1B  
Aqueous-Film-Forming-Foam Collector

A-222. The collector should be placed at the proper distance from the nozzle to be in the center of the pattern to be sampled. The nozzle should be placed in operation with the foam pattern off to one side of the collector until equilibrium is reached and then swung over onto the center of the backboard. When sufficient foam volume has accumulated to fill the sample containers (usually only a few seconds), a stop watch should be started to provide the zero time for the drainage tests described in Section A-240 and then the foam pattern should be directed off to one side again. Immediately after the nozzle has been swung away from the board, the sample container is removed, pans are removed, the top struck off with a straight edge, and all foam wiped off from the outside of the container. The sample is then ready for analysis.

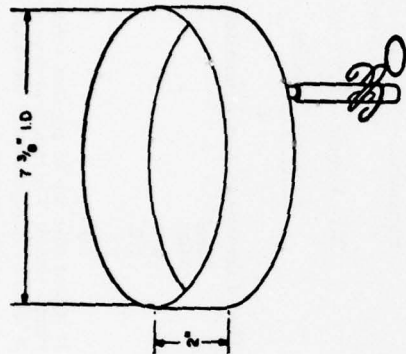

Figure 2. Protein Foam Container

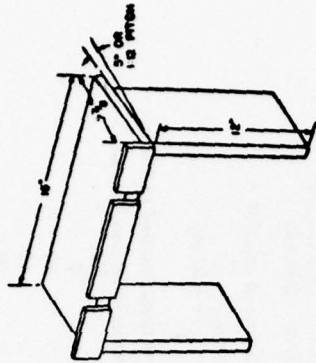

Figure 3. Protein Foam Container Stand

A-223. At the time the turret patterns are being established it will usually be convenient to obtain the foam samples for physical property tests. This may be done by swinging the turret off to one side to permit the pattern to fall on the foam sampling collector board as described above.

A-224. Different foam sample containers are used for collecting foams generated by protein-type foam-liquid concentrates (including the fluoroprotein type) as distinct from AFFF type concentrates (see Figures 1A and 1B).

a. **Collecting Foam Samples Generated by Protein-Type Foam-Liquid Concentrates.** The standard sample container is 2 inches deep and 7 3/8 inches inside diameter (capacity of 1400 milliliters) preferably made of 1/8-inch-thick aluminum or plastic. In the bottom at the edge, a 1/4-inch drain tube with a rubber tube and pinch cock is provided to draw off the foam solution as it accumulates. This device is shown in Figure 2.

b. **Collecting Foam Samples Generated by AFFF-Type Foam-Liquid Concentrates.** The standard container is a one-liter capacity graduated cylinder approximately 14 inches in height and 2 1/2 inches in inside diameter. Either transparent plastic (polypropylene, Nalgene TPX) or glass cylinders may be used, however, the standard graduations on the plastic ones may be missing below 100 ml. and this is usually in the desired working range. For this reason 10 ml. graduation marks will probably have to be marked on the cylinders below 100 ml. In addition, each cylinder shall be cut off at the 1000 ml. mark to ensure a fixed volume of foam as a sample (see Figure 1B).

**A-230. Foam Expansion Determination**

A-231. The following apparatus is used in determining foam expansion data. (The type foam collector and sample container will depend on whether protein or AFFF-type concentrates are used (see A-224).)

- a. 2 — sample containers
- b. 1 — foam collector board
- c. 1 — scale or balance, 1000 gram capacity, weighing to nearest gram.
- d. 2 — work sheet forms (see Appendix B)

A-232. Protein foam samples obtained in the sample pan as described in A-224(a) should be weighed to the nearest gram. The expansion of the foam is calculated by the following equation:

$$\text{Expansion} = \frac{1400 \text{ ml.}}{\text{full wt. minus empty weight (grams)}}$$

A-233. AFFF foam samples obtained in the graduates as described in A-224(b) should be weighed to the nearest gram. The expansion of the foam sample is calculated by the following equation:

$$\text{Expansion} = \frac{1000 \text{ ml.}}{\text{full wt. minus empty weight (grams)}}$$

**A-240. Foam Drainage Time Determination**

A-241. The rate at which the liquid drops out from the foam mass is called the "drainage rate" and this rate is a direct indication of degree of stability and the viscosity of a foam. A single value used to express the relative drainage rates of different foams is the "25 per cent Drainage Time"; this is the time in minutes that it takes for 25 per cent of the total liquid contained in the foam in the sample containers to drain out. This test is performed on the same sample as used in the expansion determination. Dividing the net weight of the foam sample by four will give the 25 per cent volume in milliliters of liquid contained in the foam.

A-242. The following apparatus is used in determining the foam's drainage time:

- a. 1 — stop watch
- b. 2 — 100 milliliter graduates (for protein-type foams)
- c. 1 — sample stand (for protein-type foams)
- d. 2 — one liter graduates, shortened (for AFFF-type foams)
- e. 2 — work sheet forms (Appendix B)

A-243. Protein-Type Foams. The protein foam sample container should be placed on a stand as shown in Figure 3 and at regular suitable intervals the accumulated solution in the bottom of the pan is drawn off into a graduate. The time intervals at which the accumulated solution is drawn off are dependent on the foam expansion. For foams of expansion 4 to 10, one-minute intervals should be used; for foams of expansion 10 and above, two-minute intervals should be used because of the slower drainage rate of foams in this category. In this way a time-drainage volume curve is obtained and after the 25 per cent volume has been exceeded, the 25 per cent drainage time is interpolated from the data.

A-244. AFFF-Type Foams. In order to find the time for the 25 per cent volume to drain out, the AFFF type foam sample container should be placed on a level surface at a convenient height and at one-minute time intervals the level of accumulated solution in the bottom of the cylinder should be noted and recorded on the work sheet. The interface between the liquid on the bottom and the foam above is easily discernible and easy to read. In this way a time-drainage volume relationship is obtained and after the 25 per cent volume has been exceeded, the 25 per cent drainage time is interpolated from the data.

A-245. Sample Calculation — Protein-Type Foams. A sample calculation of expansion and drainage time, using protein foam as an example is as follows:

The net weight of the foam sample in the pan has been found to be 200 grams. Since one gram of foam solution occupies a volume of essentially one milliliter (ml.) the total volume of foam solution contained in the given sample is 200 ml.

$$\text{Expansion} = \frac{\text{volume of foam}}{\text{volume of solution}} = \frac{1400 \text{ ml.}}{200 \text{ ml.}} = 7$$

$$25\% \text{ Volume} = 0.25 \text{ total volume of solution} =$$

$$\frac{\text{Volume of solution}}{4} = \frac{200 \text{ ml.}}{4} = 50 \text{ ml.}$$

Then if the time-solution volume data has been recorded as follows:

Time Min.	Drained Solution Volume Ml.
0	0
1.0	20
2.0	40
3.0	60

It is seen that the 25 per cent volume of 50 ml. lies within the 2 to 3 minute period. The increment to be added to the lower value of 2 minutes is found by interpolation of the data:

$$\frac{50 \text{ ml. (25\% Volume)} - 40 \text{ ml. (2 min. Volume)}}{60 \text{ ml. (3 min. Volume)} - 40 \text{ ml. (2 min. Volume)}} = \frac{10}{20} = 0.5$$

Therefore, the 25 per cent drainage time is found by adding 2.0 min. + 0.5 min. and gives a final value of 2.5 min.

A-246. In the handling of unstable foams it must be remembered that they lose their liquid rapidly and the expansion determination must be carried out with speed and dispatch in order not to miss the 25 per cent drainage volume. It may even be necessary to defer the expansion weighing until after the drainage curve data has been recorded. The stop watch is started at the time the foam container is filled and continues to run during the time the sample is being weighed.

#### A-250. Concentration Determination

A-251. This test is made to determine the percentage of foam concentrate (protein type or AFFF type) solution being supplied to the foam makers. The test is based on using a hand refractometer to measure the refractive index of the solution which varies proportionally to the concentration.

A-252. The first step in this procedure is to prepare a calibration curve for the intended use. This has been found necessary because the source of water and brand or mixture of foam concentrate will affect the results. Using water from the tank and foam concentrate from the tank, standard solutions of 3, 6, and 9 per cent are made up by pipetting 3, 6, and 9 milliliters of foam concentrate respectively into three 100 milliliter graduated and then filling to 100 milliliter mark with the water. After thoroughly mixing, a refractive index reading is taken of each standard. This is done by placing a few drops of the solution on the refractometer prism with a medicine dropper, closing the cover plate and observing the scale reading at the dark field intersection. (See Figures 4, 5, and 6.) A plot is made on graph paper of scale reading against the known foam solution concentrations and serves as a calibration curve for this particular foam test series. Portions of solution drained out during the previously described drainage rate test are conveniently used as a source of sample for the refractometer in analysis. Refractive readings of the unknown are referred to the calibration curve and the corresponding foam solution concentration read off.

NOTE: All refractometer measurements should be conducted at the calibration temperature or appropriate temperature correction factors applied.

#### A-253. Apparatus Needed

- a. 3 — 100 milliliter graduates
- b. 1 — measuring pipette (10 milliliter capacity)
- c. 1 — 100 milliliter beaker
- d. 1 — 500 milliliter beaker
- e. 1-Hand Refractometer (American Optical Co. Model 10430 or equivalent.) There are numerous refractometers of this general type available. The scale markings may vary but this is not important because the user must make his own calibration.



Figure 4. The index of refraction is measured by placing a few drops of the solution to be tested on the prism of a refractometer and closing the cover plate. This is a typical refractometer suitable for this purpose.



Figure 5. When this type refractometer is held up to a light source a reading is taken where the dark field intersects the numbered scale.

lish their protective patterns. If variation is to be expected in nozzle performance due only to partial component operation, this condition should be reproduced and tested.

A-262. At the time the handline nozzle patterns are being taken it will usually be convenient to obtain the foam samples for the physical property tests. This may be done by swinging the nozzle off to one side to permit the foam to fall on the foam collector board described in Section A-210.

A-263. The foam samples are to be analyzed as outlined in Section A-230, 240, and 250.

### A-300. FOAM PATTERN TESTS

#### A-310. Typical Turret Pattern Plot

A-311. Figures 7A, 7B, 7C and 7D show typical plots of the ground patterns of the foam discharge of a turret nozzle which may be used as a model for reporting these and similar patterns. Figure 7E shows how stakes are laid out for measuring the pattern, Figure 7F illustrates a foam turret application, and Figure 7G how measurements are made.

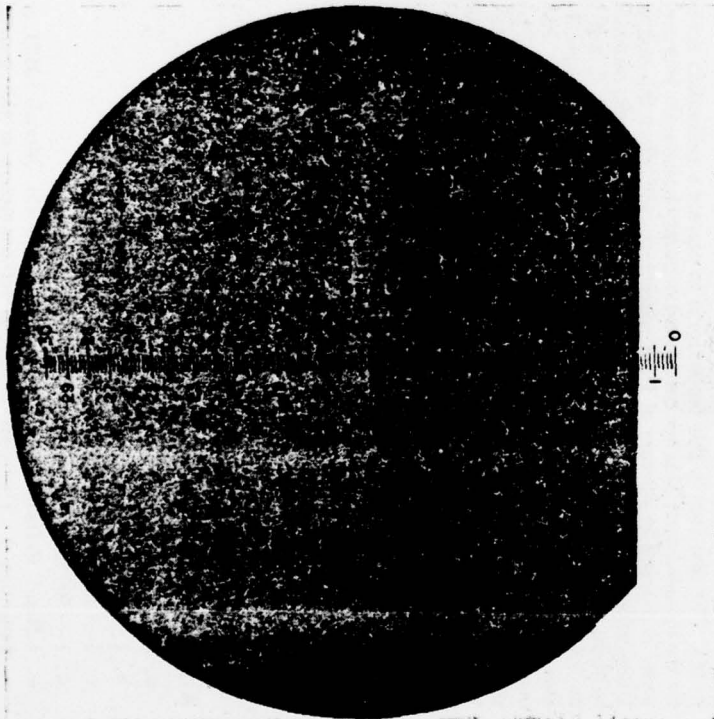

Figure 6. This illustrates the field of view looking into the refractometer illustrated in Figures 4 and 5 containing a 6 per cent AFFF Solution. The dark field intersects the scale at 1.7 and this value is recorded as the reading for a 6 per cent concentration.

#### A-260. Hand Line Test

A-261. The hand line foam nozzle, operating at its recommended pressure, shall discharge foam onto a paved surface for the purpose of determining the output pattern. The nozzle should be held at its normal working height and tilted upward to form a 30-degree angle with the horizontal. Markers shall be set out to denote the outline of the effective foam pattern and plotted, as described under the turret test above. The resultant patterns from both the straight stream nozzle setting and the fully dispersed nozzle setting should be established.

a. Auxiliary nozzles such as bumper and undertruck nozzles (if any) should be operated, elevated for maximum range (if applicable), to estab-

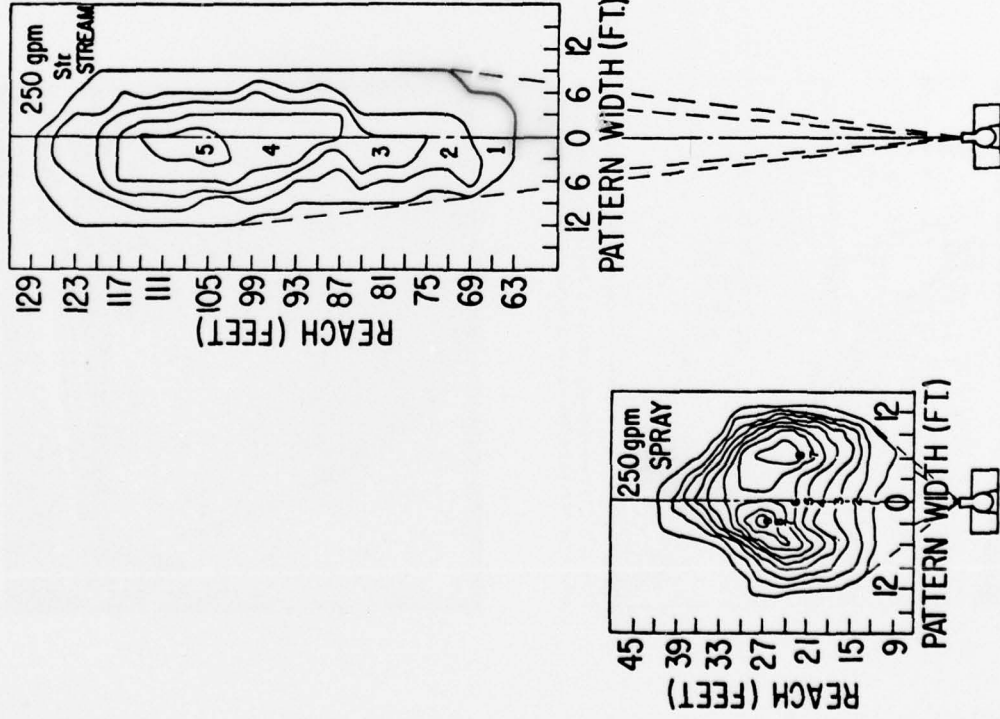

Figure 7A (left) and 7B (right). A plot of the values from a foam pump discharge looks like this. The discharge rate is 250 gpm of foam solution. The straight stream pattern (7B) is compact and of good range and shows a minimum of "weeping." The full spray pattern (7A) shows a width of about 25 ft. out to a distance of about 28 ft. Area within the 1/2-inch depth line is slightly over 800 square feet. Water density 0.30 gpm per square foot.

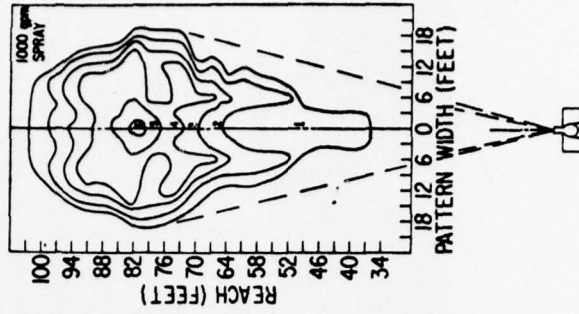
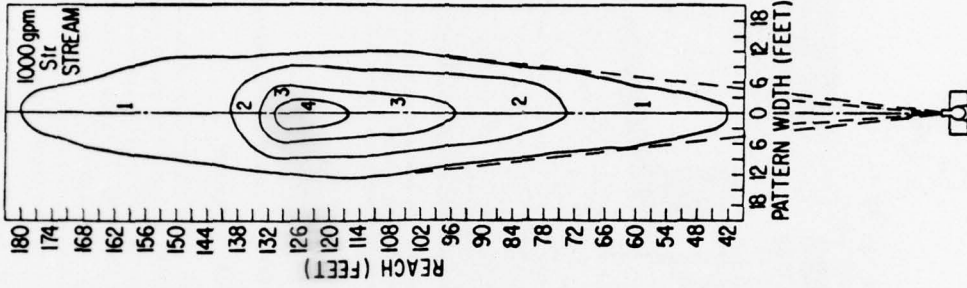

Figure 7C (left) and 7D (right). This shows a 1,000 gpm dual capacity, aspirating nozzle discharge. For the straight stream (7C) note the maximum and minimum reach. For the spray (7D), note the maximum width and best reach.



Figure 7E. Stakes are laid out on 3-foot centers forming a grid over the expected foam ground pattern.

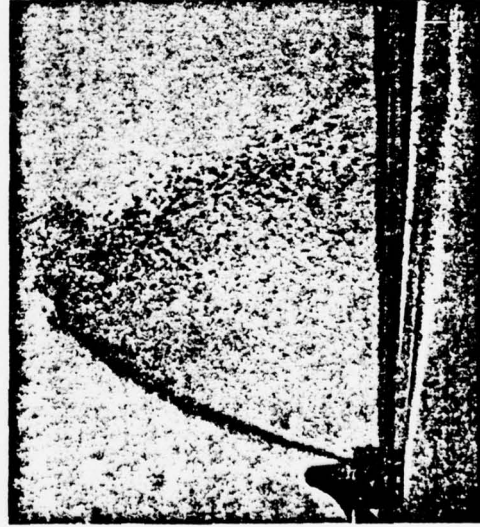

Figure 7F. Foam is discharged over the grid area for a period of 30 seconds.

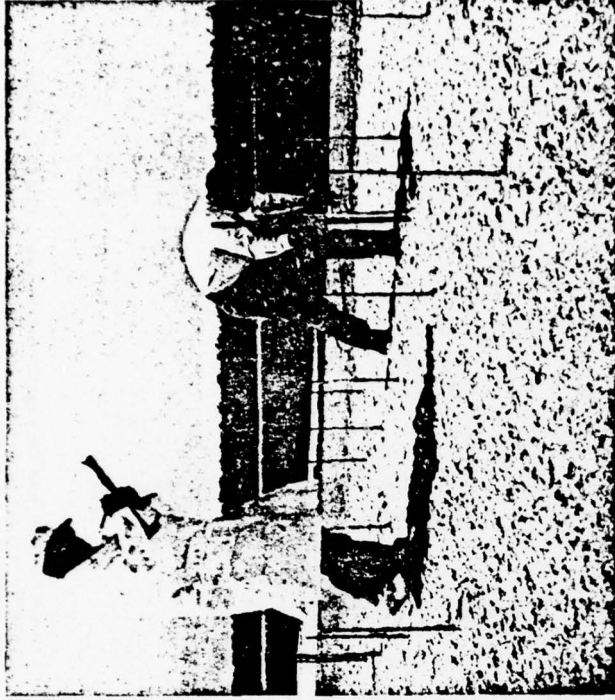

Figure 7G. Immediately after applying foam, measurements are taken of the foam at each marker. Speed is important here as the foam tends to slide around as the foam solution drains out and begins to run off.

### A-500. Temperature Corrections

#### A-510. Purpose

A-511. The temperature of the water in solution with protein foam liquid concentrates influences the expansion and drainage time values. Thus, if the physical property tests are conducted at temperatures varying widely from the 60-80° F. range as recommended herein, a correction should be applied to the results. The temperature of the water used in making the foam is much more influential in controlling the final solution temperature than is the air temperature.

A-520. Solution temperature variations cause opposite effects in the properties of protein type foams. The expansion goes down with lower temperatures but the drainage time goes up, and vice versa.

**A-530.** The following corrections apply for protein foam:

Expansion — If the solution temperature was higher than 70°F, apply no correction.

If the solution temperature was lower than 70°F, add 0.1 unit of expansion for each 3° below 70°.

Drainage Time — If the solution temperature was higher than 70°F, add 0.1 min for each 3°F above 70°.

If the solution temperature was lower than 70°F, subtract 0.1 min for each 3°F lower than 70°.

**A-540.** No temperature correction factors have been developed for AFFF.

#### **A-600. FOAM FIRE TEST**

##### **A-610. Turret or Handline Extinguishing Test**

**A-611.** The exact size of the fire to be used is not critical, however, it should be no less than 100 ft<sup>2</sup> (10 x 10) in area. Large-scale testing has shown that larger area fires do not necessarily require greater application rates or greater quantities of agent (foam) per unit area. The choice of fuel is optional, depending on the data desired. Gasolines are normally the most difficult fuels to extinguish and Jet A (JP-5) the easiest. Jet B (JP-4) is a variable fuel without a specified flash point. Normally the fuel will be contained in a shallow pit or diked area on concrete. Water may be used to level a large pit to ensure a full fuel area but in any event bare ground should be presoaked to prevent loss of fuel. The amount of fuel is partially dependent on the length of preburn to be allowed. With preburn times of one minute, at least one gallon of fuel for each two square feet of area should be used. Local clean air regulations may dictate the length of preburn as this is the period of greatest smoke generation.

**A-612.** Establishing and maintaining the desired rate of foam application will require some work and practice prior to the conduct of the fire test. The object is to sweep the turret or nozzle back and forth over the fire area at an even rate in order to apply the foam at the desired gallons-per-minute (gpm) per square foot. The actual rate is checked by placing one foot square (or other convenient size of known area) shallow pans near the edges of the fire area. After the foam discharge pattern has been swept back and forth over the fire area and pans for a measured period of time, the stream is shut off and the weight of the contents of each pan determined and the application rate calculated. If the rate has been too high, a faster rate and wider angle of sweep will be necessary and vice versa. Once the proper technique has been worked out, the fire is extinguished in the same manner. The pans can be used during the fire test to verify the application rate. NFPA No. 403 recommends a rate of 0.13

gpm per square foot for AFFF and 0.20 gpm per square foot for protein foam.

**A-613.** The following calculations are typical of those used in the determination of the basic extinguishing capability of an aircraft rescue and fire fighting vehicle of 1000 gallon water capacity:

Gross weight of pan with collected foam . . . . . 412 oz  
 Empty weight of pan . . . . . 350  
 Net weight of foam sample . . . . . 62 oz

Water collected =  $\frac{\text{foam wt., oz}}{133.3} = \frac{62}{133.3} = 0.465$  gallons

Total water applied =  $\frac{\text{water collected, gal}}{\text{area of pan, ft}^2} = \frac{0.465}{3.5} = 0.133$  gal/ft<sup>2</sup>

Foam application rate =  $\frac{\text{gallons applied per ft}^2}{\text{time of foam discharge, min}} = \frac{0.133}{1.0} = 0.133$  gpm/ft<sup>2</sup>

Basic extinguishing capability =  $\frac{1000 \text{ gal}}{0.133 \text{ gal/ft}^2} = 7600 \text{ ft}^2/1000 \text{ gal water}$

#### **A-620. Burnback Test**

**A-621.** The resistance of the foam blanket on the fuel to burnback after the fire has been extinguished is of importance. In the determination of this property wind plays a big role and repeat results are difficult to obtain on an outdoor test. Another factor, but one easier to control, is the size of the fire area at the start of reignition. In order to standardize this a short section of stovepipe 12-inches in diameter is dropped into the foam blanket like a cookie cutter. The foam is removed from the inside, the fuel surface ignited and allowed to burn for one minute before the stovepipe is removed. The rate of enlargement of the fire is then observed. A long period of confinement is desired. The delay period after end of foam application and start of reignition may be varied but for comparative tests it must be kept constant.