

AD-A047 371

ADVISORY GROUP FOR AEROSPACE RESEARCH AND DEVELOPMENT--ETC F/G 14/2  
A CATALOGUE OF CURRENT IMPACT DEVICES, (U)  
SEP 77 D H GLAISTER

UNCLASSIFIED

AGARD-R-658

NL

1 OF 1  
AD  
A047371



END  
DATE  
FILMED  
1 - 78  
DDC

# AGARD

ADVISORY GROUP FOR AEROSPACE RESEARCH & DEVELOPMENT

7 RUE ANCELLE 92200 NEUILLY SUR SEINE FRANCE

AD A 0 4 7 3 7 1

AGARD REPORT No. 658

## A Catalogue of Current Impact Devices

A Working Group Report

Edited by

D.H. Glaister



NORTH ATLANTIC TREATY ORGANIZATION



AD NO.

DDC FILE COPY

DISTRIBUTION AND AVAILABILITY  
ON BACK COVER

DISTRIBUTION STATEMENT A  
Approved for public release;  
Distribution Unlimited

NORTH ATLANTIC TREATY ORGANISATION  
ADVISORY GROUP FOR AEROSPACE RESEARCH AND DEVELOPMENT  
(ORGANISATION DU TRAITE DE L'ATLANTIQUE NORD)

6 AGARD Report No.658  
A CATALOGUE OF CURRENT IMPACT DEVICES

A WORKING GROUP REPORT

Edited by David

10 Wing Commander D.H. Glaister, RAF

11 Sep 77

12 61p.

This Report was prepared at the request of the Aerospace Medical Panel of AGARD.

400 043

LB

## THE MISSION OF AGARD

The mission of AGARD is to bring together the leading personalities of the NATO nations in the fields of science and technology relating to aerospace for the following purposes:

- Exchanging of scientific and technical information;
- Continuously stimulating advances in the aerospace sciences relevant to strengthening the common defence posture;
- Improving the co-operation among member nations in aerospace research and development;
- Providing scientific and technical advice and assistance to the North Atlantic Military Committee in the field of aerospace research and development;
- Rendering scientific and technical assistance, as requested, to other NATO bodies and to member nations in connection with research and development problems in the aerospace field;
- Providing assistance to member nations for the purpose of increasing their scientific and technical potential;
- Recommending effective ways for the member nations to use their research and development capabilities for the common benefit of the NATO community.

The highest authority within AGARD is the National Delegates Board consisting of officially appointed senior representatives from each member nation. The mission of AGARD is carried out through the Panels which are composed of experts appointed by the National Delegates, the Consultant and Exchange Program and the Aerospace Applications Studies Program. The results of AGARD work are reported to the member nations and the NATO Authorities through the AGARD series of publications of which this is one.

Participation in AGARD activities is by invitation only and is normally limited to citizens of the NATO nations.

The content of this publication has been reproduced directly from material supplied by AGARD or the author.

Published September 1977  
Copyright © AGARD 1977  
All Rights Reserved

ISBN 92-835-1256-1



*Printed by Technical Editing and Reproduction Ltd  
Harford House, 7-9 Charlotte St, London, W1P 1HD*



# A CATALOGUE OF CURRENT IMPACT DEVICES

by

Wing Commander David H. Glaister  
Royal Air Force Institute of Aviation Medicine  
Farnborough, Hampshire, UK.

## PREFACE

Early in 1972, a Working Group was set up under the auspices of NATO/AGARD Aerospace Medical Panel. Its brief was to consider standardisation of biodynamic impact testing with special reference to helmets, seats and harnesses. The Working Group first met on 29th May, 1972, in Brussels, and areas were defined where standardisation was required between member nations of NATO. One of these areas, the testing of protective helmets for aircrew, has formed the basis for a Working Group Report (AGARD Report No. 629) published in February 1975. Another area considered appropriate was standardisation of impact test facilities, for many such facilities existed within the NATO biodynamic community, but they operated in different ways, imposed diverse impact conditions and utilised varied recording techniques. The approach suggested by the Working Group leader was to compile a "Catalogue of Impact Devices" which would summarize the features of each device on a comparative basis. With this aim in view questionnaires were sent to all known impact research laboratories and, by the time of a meeting of the Working Group held in Soesterberg in September 1973, details of 42 impact test devices had been obtained. Then followed the dissolution of the Working Group and a prolonged period of collation, correction and in some cases, translation.

Study of the completed questionnaires showed such differences in construction and mode of operation of impact devices that it was felt necessary to add a section describing the common and some of the more unique features. In addition many devices, particularly in the United States, were found to use a common propulsion system and it was decided to describe this system in some detail. Whilst most of the members of the Working Group, listed below, contributed on behalf of their own Nation's facilities, the help of Lt. Col. George Kush, who undertook to correct, collate and update information on devices within the American continent, is gratefully acknowledged.

The members of the Working Group were:

Wg Cdr D.H. Glaister, RAF Institute of Aviation Medicine, Farnborough, UK (Working Group Leader).

Gp Capt P. Howard, RAF Institute of Aviation Medicine, Farnborough, UK (Chairman).

Dr R. Auffret, Centre d'Essais en Vol, Brétigny-sur-Orge, France.

Mr J.W. Brinkley, Aerospace Medical Research Laboratory, Wright-Patterson Air Force Base, USA.

Mr W. Law, Naval Air Development Centre, Johnsville, USA.

Lt Col G. Paolucci, Centro Ricerche Medicina Aerospaziale, Roma, Italy.

Col W. Potten, Flugmedizinisches Institut der Luftwaffe, Furstenfeldbruck, Germany.

Dr R.G. Snyder, Highway Safety Research Institute, Michigan, USA.

## CRASH IMPACT TESTING

The function of test impact devices used in aerospace research is to duplicate, under controlled experimental conditions, the acceleration-time histories of impacts which may occur, usually as the result of an accident, in aircraft, or space vehicles. The object of the research may be to study vehicle structures, or cockpit integrity; but the Aerospace Medical Panel has a particular interest in occupant survivability and effectiveness. Since the forces of greatest interest are those bordering on the injurious, or lethal, the subject of experimentation will rarely be man, but animal analogues, human cadavers, or anthropomorphic dummies will generally be utilised. Data will also be obtained for the definition of mathematical models which should eventually make the use of human experimentation less essential.

Of necessity, high level impact forces entail considerable velocity changes and it is inevitable that these occur in aerospace accidents. However, the automobile also attains high speeds and is more frequently involved in crashes. Furthermore, the occupant is not concerned with the type of vehicle, but only with the forces involved, the system of restraint used and any local structures with which he may come into contact. Thus, automobile and aircraft crashes are comparable and the aerospace community has much to learn from research carried out by the automobile industry. This conclusion is supported by the many impact devices listed here which are operated by motor manufacturers, and by their contribution to impact research as evidenced by proceedings of the Stapp Car Crash Conferences, or conferences organised by the International Research Committee on Biokinetics of Impacts (IRCOBI).

Impact devices may be arranged to operate horizontally or vertically, so that the gravitational vector may be perpendicular to, or along the axis of the imposed impact acceleration vector. Furthermore, the devices may be accelerators (the test object being suddenly accelerated from rest and subsequently brought gently to a standstill), or decelerators (the test object being gently accelerated and then brought abruptly to rest). This catalogue lists 15 horizontal accelerators, 21 decelerators, and three devices which produce impact by rebound. In a vertical test facility, of which 12 examples are listed, the gravitational vector can either add to, or subtract from the imposed impact, depending upon whether the test object is impacted following free-fall, or by being suddenly accelerated upwards.

Chandler (1971) has drawn attention to differences in the force environment immediately preceding and following a test impact, and this may have a considerable bearing on test results. Thus, prior to the test the subject could be stationary and unaware of the impending impact, or could be in free-fall, or accelerating, or coasting towards a visible barrier. Psychological factors are also important, particularly if the test is designed to look at aspects of human performance and, certainly at low levels of impact, considerable differences in response are seen depending upon whether the impact can be anticipated.

Another potent source of variability in experimental impacts using dummies is the dynamic response of the dummy. This varies from virtually nil with some life-like, but inert space-models, to be quite representative in what may appear to be a far less realistic dummy. However, even a dynamic dummy may only respond correctly along a single axis. Thus, dummies can behave quite differently even when used as space models to assess clearances between extremities and surrounding vehicle structures. This catalogue gives details of the dummy inventory currently used on the various impact test facilities.

A brief acquaintance with impact acceleration literature yields many examples of incomplete experimental details. For example, peak acceleration and total pulse duration may be quoted, but the pulse waveform and imposed velocity change are left to the imagination of the reader. Knowledge of the impact device, in particular the stroke and maximum velocity change of which it is capable, should help to fill in some of the gaps.

Another important factor is possible interaction between the test subject and the vehicle which carries it at the time of impact. Thus, if the payload is more than about one tenth of the weight of the vehicle on which it is carried, any dynamic response of the payload will significantly alter the impact characteristics of the vehicle - that is, the inertia of the braked, or accelerated mass will vary dynamically during the

impact. For this reason, typical payload/vehicle mass ratios are quoted when available. Similarly, the siting of acceleration transducers and the frequency response of the entire recording system - transducers, amplifiers, filters and recorders - need to be known if reported results are to be interpreted correctly. These data, too, are given where known.

Two further features of the catalogue may prove of value. It provides a source of information for anyone wishing to make use of an impact facility who does not have immediate access. The catalogue will tell him where a suitable facility might be found, whether it could carry the projected payload and what its impact performance would be. Finally, the catalogue refers to published papers in which may be found more detailed descriptions of the construction, operation and use of the individual facilities.

#### The Hyge Accelerator

Whilst differences between the various impact test devices have been stressed, many of them, particularly in North America, share a common actuating mechanism. This is the Dynatest HY-12138, or Hyge, manufactured by the Scientific Instruments and Equipment Division of Bendix, and a more detailed description is given here to save duplication later. (Fuller details may be found in 'Installation and Operating Instructions for Hyge Shock Tester', VE No 38326, The Bendix Corporation, June 1972.)

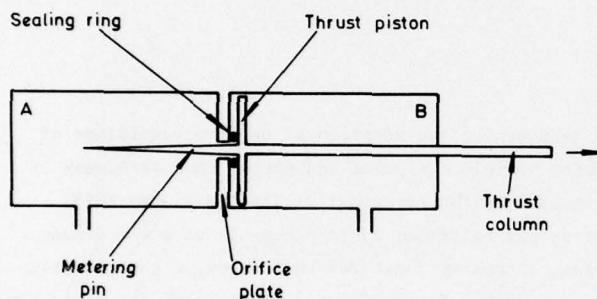

Fig. 1. Basic operation of the Hyge Shock Tester.

The Hyge device uses air pressure, acting on a piston, to apply a sudden thrust to a vehicle which then coasts along a track before being brought gently to rest. The operation of the system may be seen from the diagram (Fig. 1). Air pressure is applied to both sides of a piston in a closed, 12 in (305 mm) diameter, cylinder divided into two 6 ft (1.83 m) long sections separated by an orifice plate. Because the piston area exposed to air pressure in compartment B is greater than that in A, a considerably lower pressure in B keeps the piston back against the seal ring on the orifice plate. As the pressure in compartment A is raised it will first balance the forces and then break the seal and displace the piston. As soon as this occurs a much larger piston area is exposed to the higher pressure and a maximum gross thrust of up to 225,000 lb (1,001 kN) is developed. Thereafter, the force/displacement profile is determined by the profile of a metering pin which controls gas flow between the two compartments. The device operates at pressures of up to 3,000 lb.in.<sup>-2</sup> (2,070 kPa), and with a vehicle weight of 2,200 lb (998 kg), and payload of 1,236 lb (561 kg), acceleration levels of up to 50 G can be obtained. With this payload the maximum acceleration occurs over 97 ms and the vehicle is accelerated to 66 mph (30 m s<sup>-1</sup>). With an increased payload of 5,080 lb (2,304 kg), these figures become 24 G, 138 ms and 46 mph (21 m s<sup>-1</sup>). A modified metering pin can be used to give square wave acceleration profiles with rise times of 25 ms, dwell times of 50 to 31 ms and acceleration plateaux of up to 32 G, for a specimen weight of 625 lb (283 kg) mounted on a 2,000 lb (907 kg) sled.

A larger, 24 in (610 mm) diameter Hyge unit can accelerate a 10,000 lb (4,536 kg) payload to 71 mph (32 m s<sup>-1</sup>) at 44 G. There are also smaller 9 in (229 mm) and 6 in (152 mm) diameter Hyge units.

An advantage claimed for this type of system (i.e. for an impact accelerator) is that the test specimen is static up to the moment of impact, so offering easier setting-up, instrumentation and photography.

However, it does imply the storage of a massive quantity of potential energy with the safety hazard that this entails. Also, whilst the device simulates the physical environment of accidental impacts (absolute values of pre-impact and post-impact velocity being relative) it cannot simulate the psychological aspects. Thus, many facilities, and the majority in Europe, are crash decelerators.

#### Other Systems

Many different methods are used in impact decelerators for the preliminary acceleration of the test vehicle to impact velocity. These vary from the sophistication of linear motors to the simplicity (and reliability) of inclined planes, falling weights, or stretched elastic bungee cords. The acceleration phase is followed usually by a coast period during which the test object is exposed only to the normal force of gravitational acceleration acting perpendicular to the test axis, before impacting with some form of braking system. This may range from a hydraulic system with metering orifices to give a controlled deceleration/displacement profile, to a simple block of crushable material. Many other energy absorbing devices are detailed in the following pages. Control of the impact waveform is governed by selection of an appropriate impact velocity and retardation force, and by the variation of the retardation force with displacement. These impact systems are usually designed for a specific test purpose and many of them are capable of creating representative crashes between two vehicles (cars or trucks), or between one vehicle and some appropriate solid object (barrier collision). Others are designed to allow investigation of the integrity of the passenger compartments, restraint systems and so on, or specifically to look at the biodynamics of impact acceleration.

#### Existing Standards

Within the United Nations there exist agreements 'concerning the adoption of uniform conditions of approval and reciprocal recognition of approval for motor vehicle equipment and parts' done at Geneva on 20 March, 1958. Addendum 15: Regulation No.16 to be annexed to the Agreement drafted on 17 May 1973 details 'uniform provisions concerning the approval of safety belts for adult occupants of power-driven vehicles'. This document describes, in detailed annexes, a trolley, seat and anchorages, a test manikin and a curve of the trolley's deceleration as a function of time. Since this agreement forms the basis for many test devices, a synopsis of the specification is included in the catalogue under the heading 'United Nations Agreement' (p.45).

A further recommended practice of relevance to this catalogue concerns 'Instrumentation for Impact Tests' (Society of Automotive Engineers, J211a). This gives guidelines for instrumentation to be used in motor vehicle and motor vehicle component impact tests with the objective of assuring meaningful comparisons of test results from different sources. Since this recommended practice is being adopted increasingly by test centres, relevant parts are quoted in the following paragraphs.

'Calibration checks should be made at  $\frac{1}{4}$ ,  $\frac{1}{2}$  and full scale for each data channel. A calibration signal equal to at least 80% full scale should be provided at the time of test. Bipolar channels should be checked in each direction. Data channels should be scaled to make allowance for higher than expected test values. Consideration should be given to the effects of test site conditions (for example, temperature). Calibration should be made on a periodic basis utilizing measuring and test equipment traceable to known standards.'

The property of a data channel is specified by a curve which plots the channel output/input ratio versus frequency of the applied calibration signal. Figure 2 shows recommended limits for the various classes of data channels listed in table 1. If the frequency response of the data channel falls entirely within the shaded area of figure 2, it meets the requirements of recommended practice SAE J211a. Values for the parameters shown in figure 2 are listed in table 2 for the four channel classes.

It is further recommended in SAE J211a that impact velocity (calculated by measuring the time required to traverse a known distance prior to impact) should be accurate to  $\pm 1\%$ , and that timing marks

needed to correlate high-speed film and other data channels should have a stability of  $\pm 1\%$  and should be synchronized within  $\pm 1$  ms.

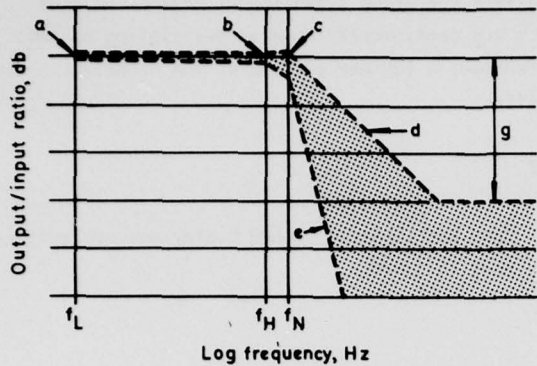

Fig. 2. Frequency response (not to scale) as recommended in SAE J211a. Numerical values for the parameters defining the lines are detailed in Table 2.

TABLE 1. EXAMPLES OF CHANNEL CLASSES

Typical Test Measurement	Channel Class
Vehicle structural accelerations for use in:	
Collision simulation	60
Component analysis	600
Integration for velocity or displacement	180
Belt restraint loads	60
Occupant:	
Head acceleration	1000
Chest acceleration	180
Sled accelerations	60

TABLE 2. FREQUENCY RESPONSE VALUES

Channel class	$f_L$ , Hz	a, dB	$f_H$ , Hz	b, dB	$f_N$ , Hz	c, dB	d, dB/octave	e, dB/octave	g, dB
1,000	0.1	+1, - $\frac{1}{2}$	1,000	+1, -1	1,650	+1, -4	-6	-24	-30
600	"	"	600	"	1,000	"	"	"	"
180	"	"	180	"	300	"	"	"	"
60	"	"	60	"	100	"	"	"	"

#### LAYOUT OF CATALOGUE

Details of each impact test facility are entered on separate pages against numbered headings. These headings are given in full on a pull-out flap at the end of the catalogue. A few facilities have been included on which information has not been adequate to justify a full page entry, and these have been referred to in conjunction with associated devices, though are separately listed in the index and summary.

Access to information on individual facilities may be obtained in three ways. An index at the end of the catalogue lists each facility under the name of the appropriate operating organisation. A summary, following this introduction, lists the facilities according to principle of operation (accelerators, decelerators, horizontal, vertical etc). Finally, the summary lists each facility of one type alphabetically by town where located. In view of the relatively small number of each type it was not considered necessary to list them additionally by country. The summary also gives brief details of the performance of each device in terms of payload, maximum acceleration and velocity change, and also states whether or not it is known to be man-rated.

It is appreciated that, within the nations of NATO, there probably exist several impact test devices which have not been included here. Furthermore, many details are lacking from the descriptions which have been included and, inevitably, there will be errors. Omissions and errors are regretted and it is hoped that the publication of this catalogue will inspire scientists operating crash impact devices to send appropriate details to the Editor. In this way a complete and continuously updated description of test devices would be available and, when appropriate, and if wanted, a further edition of the catalogue could be produced without the delays inevitable in an initial effort.

#### REFERENCE

Chandler, R.F. (1971). Design considerations for Impact Test Facilities. AGARD Conference Proceedings No 88 on Linear Acceleration of Impact Type, pp B1-1 to B1-10.

SUMMARY

IMPACT ACCELERATORS - HORIZONTAL

Pulse shaping	Payload, kg	Accn, G (1)	$\Delta$ Velocity, m s <sup>-1</sup> (1)	Man- rated	Location	Page
Hyge 12	1,360	72	26.8	Yes	Buffalo, NY, USA	1
Hyge 12	1,180	70	26.8	No	Chelsea, Michigan, USA	2
Hyge 12	1,270	80	26.8	No	Dearborn, Michigan, USA	3
Hyge 12	1,372	50	26.8	No	Detroit, Michigan, USA	4
Electrohydraulic	250	30	15.0	Yes	Dortmund, Germany	5
Hyge 24	4,536	100	42.5	Planned	East Liberty, Ohio, USA	6
Hyge 9	1,360 (2)	50	26.8	Yes	Glendale, California, USA	7
Hyge 12	2,270 (2)	50	26.8	No	Milford, Michigan, USA	8
Hyge 6	400	30	13.9	No	Munich, Germany	9
Hyge 12	2,250 (2)	200	40.0	Yes	New Orleans, LA, USA	10
Hydropneumatic	680	40	42.5	Yes	Philadelphia, PA, USA	11
Flywheel and clutch	227	50	15.6	No	Riverdale, Maryland, USA	12
Hyge 12	2,500 (2)	80	36.1	No	Sindelfingen, Germany	13
Hyge 12	2,270 (2)	50	26.8	No	Southfield, Michigan, USA	14
Pneumatic	4,536	150	51.5	Yes	Wright-Patterson, Ohio, USA	15

- VERTICAL

Ejection catapult	(3)	40	(3)	Yes	Brétigny-sur-Orge, France	16
Ejection catapult	(3)	20	20.9	Yes	Farnborough, England	17
Pneumatic	(3)	150	(3)	Yes	Holloman AFB, New Mexico	18
Hydraulic	100	10	6.0	Yes	Loughborough, England	19
Ejection catapult	(3)	(3)	(3)	(3)	Philadelphia, PA, USA	11

- CENTRIFUGE

Pneumatic	(3)	40	(3)	to 15 G	Brétigny-sur-Orge, France	20
-----------	-----	----	-----	---------	---------------------------	----

REBOUND IMPACT DEVICES - HORIZONTAL

Pneumatic	556	75	33.5	No	Ann Arbor, Michigan, USA	21
(3)	272	45	15.6	No	Detroit, Michigan, USA	22
Piston	1,360	60	31.3	Yes	San Antonio, Texas	23

- Notes
- (1) Not necessarily concurrently, or at stated payload
  - (2) Includes sled
  - (3) Details not available

IMPACT DECELERATORS - HORIZONTAL

Pulse shaping	Payload, kg	Accn, G	$\Delta$ Velocity, m s <sup>-1</sup>	Man- rated	Location	Page
Hydraulic, or barrier	2,860	70	27.3	No	Atlantic City, NJ, USA	24
Deformed steel strip	150	(3)	(3)	Yes	Berlin, Germany	25
(3)	(3)	50	(3)	No	Bretigny-sur-Orge, France	26
Deformed plastic tube	300	30	19.4	No	Bron, France	27
Collision	(3)	(4)	24.0	No	Buxton, Derbyshire, England	28
Barrier crash	1,135	(4)	15.2	No	Dayton, Ohio, USA	29
Hydraulic snubber	1,815	50	26.8	Yes	Detroit, Michigan, USA	30
Barrier Crash	910	50	17.9	(3)	Detroit, Michigan, USA	31
(3)	136	50	13.4	(3)	Detroit, Michigan, USA	32
Cable to hydraulic piston	250	50	15.2	Yes	Farnborough, England	33
Deformed steel strip	280	40	19.5	No	Frankfurt, Germany	34
Deformed steel strip	100	40	27.8	No	Heidelberg, Germany	35
Hydraulic piston	454	80	53.3	Yes	Holloman AFB, New Mexico	36
(3)	(3)	25	6.1	Yes	Holloman AFB, New Mexico	36
Barrier crash	4,536	(4)	17.9	Planned	Nuneaton, Warks, England	37
Lead cones and hydraulic piston	635	30	17.9	No	Oklahoma City, USA	38
Friction brake	41	300	18.3	No	Oklahoma City, USA	38
Paper honeycomb, or extrusion straps	454	60	15.2	No	Phoenix, Arizona, USA	39
Lead buffers, or air piston	(3)	>2,000	(3)	No	Rome, Italy	40
Barrier crash	10,000	(4)	25.0	No	Sindelfingen, Germany	41
Barrier crash, or hydraulic piston	2,000	(3)	22.2	No	Turin, Italy	42

- VERTICAL

Hydraulic piston	(3)	100	11.6	(3)	Houston, Texas	43
Hydraulic, or tear webbing	100	5	6.0	Yes	Loughborough, England	19
Springs and hydraulic pistons	(3)	>200	8.5	Yes	Oklahoma City, USA	38
Various materials	(3)	(3)	15.2	(3)	Oklahoma City, USA	38
(3)	(3)	100	30.0	(3)	Philadelphia, PA, USA	11
(3)	(3)	(3)	23.2	No	Phoenix, Arizona, USA	39
Hydraulic piston	907	80	17.1	Yes	Wright-Patterson, Ohio, USA	44

- Notes (3) Details not available  
 (4) Variable depending upon vehicle characteristics

1. Impact Accelerator  
Calspan (Cornell Aerospace Laboratories)  
Buffalo, N.Y., USA.
2. Hyge 12 accelerator (see Introduction, p. vi).
3. October 1968.
4. A man-rated decelerator used for harness and vehicle design and for physiological and biodynamical research, particularly dummy response testing. Test material includes human subjects, dummies and cadavers. Crash barrier also used.
- 5a. Track 94 ft (28.7 m) long.
- b. Sled weighs 2,000 lb (907 kg) and measures 4 ft (1.2 m) wide by 12 ft (3.7 m) long.
- c. Nominally 3,000 lb (1,360 kg) and up to 13 ft (4.0 m) wide by 15 ft (4.6 m) long.
- 6a. 50 G at 5,000 lb (2,270 kg).
- b.
- c. 60 mph ( $26.8 \text{ m s}^{-1}$ ) at 5,000 lb (2,270 kg).
- d. 6 ft (1.8 m).
- e. Half sine, square, sawtooth (to 72 G). Pulse width up to 130 ms.
- f. Peak G  $\pm$  2.5%, velocity change  $\pm$  2.5%.
- 7a. 52 channels on tape.
- b. Flying lead.
- c.
- d. Sled velocity, harness loads, high speed cine (on-board at up to 40 G) at 1,200 to 3,000 frames  $\text{s}^{-1}$  (Stalex and Photosonics cameras).
8.
 

50%ile Sierra male	(4)	'6 yr old' Sierra	(2)
95%ile Sierra male	(1)	50%ile Alderson male	(3)
5%ile Sierra female	(2)	95%ile Alderson male	(1)
'3 yr old' Sierra	(2)	Hybrid humanoid type 2, P50	(4)
- 9.
- 10.
11. Uses include tests on restraint systems (belts and airbags), child seats, two vehicle crashes, measurement of Chest Injury Criteria and Head Injury Criteria. Hyge unit has 10 metering pins including an in-house design.

- 1. Impact Accelerator  
Chrysler - Proving Ground Section  
Chelsea,  
Michigan, USA.
- 2. Hyge 12 Accelerator (see Introduction, p. vi).
- 3. February 1968.
- 4. Tests on car seats, child seats, dashboards, restraint systems (belts and airbags) and on vehicles against barriers, using dummies.
  - 5a. Track 140 ft (42.7 m) long.
  - b. Sled weighs 2,400 lb (1,089 kg) and measures 4 ft (1.2 m) wide by 12 ft (3.7 m) long.
  - c. 2,600 lb (1,180 kg) with allowable overhang.
  - 6a. 30 G at 5,000 lb (2,268 kg) to 70 G with small payload.
  - b.
  - c. 60 mph ( $26.8 \text{ ms}^{-1}$ ) at 5,000 lb (2,268 kg).
  - d. 6 ft (1.8 m).
  - e. Half sine, square, sawtooth, with pulse width up to 130 ms. Irregular with barrier impact.
  - f. Peak G  $\pm$  2.5%, velocity change  $\pm$  2.5%.
  - 7a. 32 channels on magnetic tape.
  - b. Flying lead plus 11 channels of telemetry.
  - c. Two or more accelerometers on 'adult' dummies.
  - d. Sled velocity, harness loads.
- 8.
 

5%ile Alderson	95%ile Sierra	(5)
50%ile Alderson	'3 yr old' Sierra	(13)
95%ile Alderson	'6 yr old' Sierra	(4)
5%ile Sierra		(2)
50%ile Sierra		(10)
- 9.
- 10.
- 11. Seat can be fixed at angular increments of 5 degrees.

1. Impact Accelerator  
Ford - Safety and Service Product Development Group  
Dearborn,  
Michigan, USA.
2. Hyge 12 accelerator (see Introduction, p. vi).
3. April 1966.
4. Studies on motor vehicle restraint systems and occupant protection using dummies.
- 5a. Track 120 ft (36.6 m) long.
- b. Sled weighs 2,200 lb (1,000 kg) and measures 4 ft (1.2 m) wide by 12 ft (3.7 m) long.
- c. Payload 2,800 lb (1,270 kg) with allowable overhang.
- 6a. 50 G at 5,000 lb (2,270 kg) total weight, 80 G at 3,000 lb (1,360 kg).
- b.
- c. 60 mph ( $26.8 \text{ ms}^{-1}$ ) at 5,000 lb (2,270 kg).
- d. 6 ft (1.8 m).
- e. Half sine, square, triangular and a 'double hump' crash signature (see 11, below).
- f. Peak G  $\pm 8\%$ , velocity change  $\pm 5\%$ .
- 7a. 36 channels on tape.
- b. Flying lead.
- c.
- d. On-board and off-board cine at  $1,000 \text{ frames s}^{-1}$  (Photosonics cameras).
8. 50%ile Alderson (26) '3 yr old' Sierra (6)  
50%ile Sierra male (20) '6 yr old' Sierra (3)  
50%ile Sierra female (1)  
95%ile Sierra (7)  
5%ile Sierra female (2)
- 9.
- 10.
11. Hyge unit metering pins include in-house designs.

1. Impact Accelerator  
Allied Chemical - Auto Products Division  
Detroit,  
Michigan, USA.
2. Hyge 12 accelerator (see Introduction, p. vi).
3. June 1972.
4. Tests on car seats and restraint systems using dummies.
- 5a. Track 150 ft (45.7 m) long.
- b. Sled weighs 1,975 lb (896 kg) and measures 4 ft (1.2 m) wide by 12 ft (3.7 m) long.
- c. 3,025 lb (1,372 kg) with allowable overhang.
- 6a. 50 G at 5,000 lb (2,268 kg).
- b.
- c. 60 mph ( $26.8 \text{ ms}^{-1}$ ) at 5,000 lb (2,268 kg).
- d. 6 ft (1.8 m).
- e. Half sine, haversine, square, sawtooth and barrier crash pulse.
- f. Peak G  $\pm 1.5\%$ , velocity change  $\pm 1.5\%$ .
- 7a. 32 channels on magnetic tape.
- b. Flying lead.
- c. Up to 3 accelerometers mounted normal to direction of travel.
- d. Sled velocity, harness loads, on-board (to 40 G) and off-board cameras at up to 3,000 frames  $\text{s}^{-1}$  (Stalex).
8. 95%ile Sierra male (3) )  
50%ile Sierra male (5) )  
5%ile Sierra female (2) ) Also used on Allied Chemical rebound decelerator (see p. 22).  
'3 yr old' Sierra (2) )  
'6 yr old' Sierra )
- 9.
- 10.
- 11.

1. Impact Accelerator  
Max-Planck-Institut für Arbeitsphysiologie,  
Dortmund,  
W. Germany.
2. Electro-hydraulic catapult. Sled subsequently slowed after a free run by hydraulic brakes acting on a centre rail.
3. 1967.
4. Biodynamic research into effect of impact on vehicles and harnesses using dummies, human subjects and cadavers.
- 5a. 17 m (free run of 2.5 to 3.5 m; braking over terminal 8 m).
- b. Sled weighs 205 kg and measures 2.4 m wide (with camera) by 2.2 m long.
- c. Up to 250 kg. Maximum width and length is 1.63 m x 1.80 m.
- 6a. Maximum acceleration, 30 G (24 G with full 250 kg payload).
- b. 30 G attained within 15 ms.
- c. Up to  $15 \text{ m s}^{-1}$ .
- d. 1.0 m.
- e. Rectangular, triangular or half sine (electronically generated).
- f. Peak G and pulse duration better than 5%.
- 7a. Five channels on UV recorder and FM tape.
- b. Flying lead with 14, individually screened, cores.
- c.  $\pm 85 \text{ G}$  inductive accelerometers with natural frequency of 1 kHz sited at centre of mass of sled and on head and chest of dummy.
- d. High speed sled mounted cine ( $1,900 \text{ frames s}^{-1}$  Stalex). Force gauges.
8. Alderson P75.
9. Bony injury in impacted cadavers.
- 10.
11. See Lange, W (1970). Simulation schwerer Auffahrunfälle mit einer elektro-hydraulischen Katapultanlage. Sonderwerk aus ATZ Automobiltechnische Zeitschrift. Nr5, 1970. (Available as RAE Library Translation LT 1886, Simulation of severe collisions with an electrohydraulic catapult system, Procurement Executive, Ministry of Defence, Farnborough, Hants. 1976.)  
Lange, W. (1971). An electro-hydraulic system for simulation of collision. Paper No B3 in AGARD Conference Proceedings No 88 on 'Linear Acceleration of Impact Type'. AGARD-CP-88-71.

1. Crash Simulator  
Transportation Research Centre  
East Liberty,  
Ohio 47319, USA.
2. Hyge 24 in actuator (see Introduction, p. vi).
3. January 1973.
4. Presently used for tests on seats and restraint systems (including airbags and child seats) with cadavers and dummies. To be man-rated.
- 5a. Track 186 ft (56.7 m) long.
- b. Sled weighs 3,600 lb (1,633 kg) and is 12 ft (3.7 m) wide by 6 ft (1.8 m) long.
- c. Payload weighs 10,000 lb (4,536 kg) and can overhang.
- 6a. 44 G at 10,000 lb (4,536 kg); 100 G at 2,000 lb (907 kg).
- b.
- c. 71 mph ( $31.7 \text{ m s}^{-1}$ ) at 10,000 lb (4,536 kg); 95 mph ( $42.5 \text{ m s}^{-1}$ ) at 1,200 lb (544 kg).
- d. 6 ft (1.8 m).
- e. Half sine, square, sawtooth with duration up to 130 ms. Also barrier impacts.
- f. Peak G  $\pm$  2.5%; velocity change  $\pm$  2.5%.
- 7a. 12 channels DC to 20 kHz, 56 channels DC to 2 kHz, on FM tape and multi-channel oscillograph.
- b. Flying lead.
- c. Two or more accelerometers on subjects.
- d. Harness loads. High speed cine at up to 1,000 frames  $\text{s}^{-1}$  off-board and at up to 3,000 frames  $\text{s}^{-1}$  on sled (Stalex, Photosonics, Hycam cameras).
8. 95%ile Alderson male (3) '6 yr old' Alderson child (6)  
50%ile Alderson male (3) Hybrid Humanoid No 572 (4)  
5%ile Alderson female (3)  
'3 yr old' Alderson child (1)
- 9.
- 10.
11. Electronic data reduction system, including digital magnetic tape and high speed electrostatic printer/plotter outputs.

1. Impact Accelerator  
American Safety Equipment  
Glendale,  
California, USA.
2. Hyge 9 in accelerator (For principle of operation, see Introduction, p. vi)
3. June 1972.
4. Seat and harness and human subjects.
- 5a. Track 70 ft (21.3 m) long.
- b. Sled weighs 1,000 lb (454 kg) and measures 4 ft (1.2 m) wide by 8 ft (2.4 m) long.
- c. 3,000 lb (1,360 kg), no overhang.
- 6a. 50 G at 500 lb (227 kg) payload.
- b.
- c. 60 mph ( $26.8 \text{ m s}^{-1}$ ).
- d. 5 ft (1.5 m).
- e. Half sine, square, irregular.
- f. Peak G  $\pm 2.5\%$ , velocity change  $\pm 2.5\%$ .
- 7a. 18 channels (up to 14 on magnetic tape or 18 on oscillograph).
- b. Flying lead.
- c. 2 accelerometer sites on sled. Triaxial accelerometers in chest and head of dummies.
- d. Real time readout, 2 high speed cine cameras.
8. 50%ile Alderson (2)  
50%ile Sierra male (2)  
95%ile Sierra male  
50%ile CGNO  
Child dummies (2)
- 9.
- 10.
11. 6 metering pins available for the 9 in Hyge unit.

1. Impact Accelerators  
General Motors - Proving Ground Section  
Milford,  
Michigan, USA.
2. Hyge 12 accelerator (see Introduction, p. vi).
3. July 1962/September 1968 (2 tracks).
4. Used for tests on seats, harnesses and vehicles with dummies.
- 5a. Tracks 168 ft (51.2 m) long.
- b.
- c. Payload 5,000 lb (2,270 kg).
- 6a. 50 G at 5,000 lb (2,270 kg).
- b.
- c. 60 mph ( $26.8 \text{ m s}^{-1}$ ).
- d. 6 ft (1.8 m).
- e. Half sine, square and sawtooth with pulse width up to 130 ms.
- f.
- 7a. 60 channels on magnetic tape.
- b.
- c.
- d.
- 8.
- 9.
- 10.
- 11.

1. Impact Accelerator  
Bayerische Motoren Werke  
8000 Munich 40,  
Riesenfeld Str, W. Germany.
2. Bendix Hyge 6 in accelerator (For principle of operation, see Introduction, p. vi).
3. 1971.
4. Investigation of car restraint systems and others aspects of car crashworthiness.
- 5a. Track 10 m long.
- b. 750 mm wide by 600 mm long.
- c. Up to 400 kg.
- 6a. 30 G at 300 kg.
- b.
- c.  $50 \text{ km h}^{-1}$  ( $13.9 \text{ m s}^{-1}$ ).
- d. 1.25 m.
- e. Half sine, trapezoidal and irregular.
- f. Velocity within 1%.
- 7a. 16 channels to analogue recorder and on line IBM 1800 computer. Linear to 1,000 Hz.
- b. Trailing lead.
- c. Hottinger-Baldwin type B 12/2000. Three of each in head, chest and pelvis of dummy, and one on the sled.
- d. Thigh forces in dummy; harness loads. High speed cine with Hitachi and Stalex cameras.
8. Sierra 50 and 95%ile male, 5%ile female, '3 yr old' child.  
Humanoid 50%ile male (Hybrid II) and '6 yr old' child.
9. Excessive belt forces.
10. Increased computer facility (HP 2100 and 3000).
- 11.

1. Michoud Accelerator Facility,  
Naval Aerospace Medical Research Laboratory,  
New Orleans,  
Louisiana 70189, USA.
2. Bendix Hyge 12 in accelerator (see Introduction, p. vi). Braking by slipper friction, on-board pneumatic brakes and a track mounted safety barrier. Two sleds.
3. October 1972, man-rated in July, 1973.
4. Testing of humans and large primates to determine dynamic response and relation to injuries of the head, neck and torso. Primarily biological research.
- 5a. Track 213 m long by 1.0 m wide.
  - b. 1. 8,900 N (910 kg) measuring 4 ft (1.2 m) wide by 12 ft (3.65 m) long.
  2. 2,600 N (265 kg) measuring 4 ft (1.2 m) by 2 ft (2.31 m).
  - c. With sled 1, 22,000 N (2,250 kg); with sled 2, 1,780 N (181 kg).  
Typical sled: payload ratio, 4:1 to 10:1.
- 6a. 75 G for 6,600 N (675 kg) payload on sled 1, 200 G for sled 2.
  - b. Selectable from 50 to 4,000 G s<sup>-1</sup>.
  - c. 132 ft s<sup>-1</sup> (40 m s<sup>-1</sup>).
  - d. Up to 5.5 ft (1.68 m).
  - e. Trapezoidal, half sine, quarter cosine, sawtooth, or irregular.
  - f. Peak G,  $\pm 1\%$ ; velocity,  $\pm 1\%$ .
- 7a. Inertial: 30 channel with 24 channel A/D capability. Magnetic disk and FM tape. Variable pass band to 5 kHz.
 

Physiological: 16 channel on FM magnetic tape. DC to 100 Hz.
FM/RF telemetry or flying lead.
Similar accelerometers mounted to give information in 6 degrees of freedom on head, neck and pelvis.
- b. Flying lead.
- c. Piezoresistive accelerometers (up to 6) on sled.
- d. Sled mounted cine at up to 500 frames s<sup>-1</sup>.  
EKG, EEG, EOG, EMG, displacement and pressures as required.
8. 21 human volunteers.  
Chimpanzee, baboon and monkey subjects.  
Alderson CG 9.8 dummy (3).
- 9.
- 10.
11. See Ewing, C.L. and D.J. Thomas (1972). Human head and neck response to impact acceleration. NAMRL monograph 21. Naval Aerospace Medical Institute, Naval Aerospace and Regional Medical Center, Pensacola, Florida 32512.

1. Impact Accelerator  
Aerospace Medical Research Department  
U.S. Naval Air Development Centre  
Warminster,  
Pennsylvania, USA.
2. A Navy designed accelerator sled powered by hydropneumatic catapult. Subsequent braking by two MKV arresting engines and final safety barrier.
3. 1949.
4. Used for tests on seats and harnesses and for physiological and biodynamical research with dummies, animals and human subjects.
  - 5a. Track 450 ft (137 m) long.
  - b.
  - c. Payload 1,500 lb (680 kg) measures 9 ft (2.7 m) wide by 4 ft (1.2 m) long.
  - 6a. 40 G at 1,500 lb (680 kg).
  - b.
  - c. 95 mph ( $42.5 \text{ m s}^{-1}$ ) at 1,500 lb (680 kg).
  - d. 8 ft (2.4 m).
  - e. Half sine and trapezoidal.
  - f. Peak G  $\pm$  5%, velocity  $\pm$  2%.
  - 7a. 48 channels with 28 on magnetic tape.
  - b. Telemetry.
  - c.
  - d.
8. Instrumented anthropomorphic dummies from 5 to 95th %ile.
9. Hardware failure, slippage or excessive stretch of harness. Breakaway of seats, survival kit failure, actuation of pyrotechnic devices.  
Head Injury Criteria (HIC), Dynamic Response Index (DRI).
- 10.
11. Details and photographs of this facility, and of an associated Drop Tower (up to 100 G) and Ejection Seat Tower (150 ft, 45.7 m tall) appear in "Principles in Biodynamics", AGARDograph No 150, pp. 64-65, 1971.  
These facilities are all sited at the U.S. Naval Air Engineering Centre, Philadelphia, Pa.



1. Accident Simulator  
Daimler-Benz AG  
7032 Sindelfingen,  
W. Germany
2. Bendix Hyge 12 in accelerator (see Introduction, p. vi).
- 3.
4. Investigation of vehicle components.
- 5a. 65 m.
- b. 1,000 kg.
- c. 2,500 kg.
- 6a. 80 G.
- b.
- c.  $130 \text{ km h}^{-1}$  ( $36.1 \text{ m s}^{-1}$ ).
- d.
- e. Sinusoidal, triangular, trapezoidal, rectangular, irregular, up to 200 ms duration.
- f.
- 7a. FM tape to SAE J211b. Test signal accuracy  $\pm 3\%$ . Maximum of 96 test positions.
- b. Flying lead.
- c. Force and acceleration transducers on sled and on dummy.
- d. High speed filming with 100,000 lux illumination.
- 8.
- 9.
- 10.
11. This accelerator replaces earlier spring powered (1959) and hydraulically braked (1965/66) devices.

1. Impact Accelerator  
Eaton Corporation - Research Centre  
Southfield,  
Michigan, USA.
2. Hyge-12 powered accelerator sled (see Introduction, p. vi).
3. March 1971.
4. Tests on airbags, restraints and car seats using dummies.
- 5a. Track 120 ft (36.6 m) long.  
b.  
c.
- 6a. 50 G at 5,000 lb (2,270 kg).  
b.  
c. 60 mph ( $26.8 \text{ m s}^{-1}$ ) at 5,000 lb (2,270 kg).  
d.  
e. Sine, half sine, square and sawtooth.  
f.
- 7a. 36 channels, 32 on magnetic tape.  
b.  
c.  
d. Real time Severity Index for head and chest.
8. 50%ile Alderson  
50%ile Sierra female (2)  
50%ile Sierra male (4)  
95%ile Sierra male  
'3 yr old' Sierra
- 9.
- 10.
11. This facility is currently 'inactive' and placed on 'standby'.

1. Impulse Accelerator  
6570th Aerospace Medical Research Laboratories,  
Air Force Systems Command,  
Wright-Patterson AFB,  
Ohio, USA.
2. A 27 ft (8.2 m) long pneumatic accelerator with metering pins. Sled stopped by friction and sled mounted brakes.
3. November 1972.
4. Used for tests on seats, harnesses and vehicles with dummy, human and animal subjects.
- 5a. Track 240 ft (73.2 m) long.
- b. Sled weighs 1,800 lb (815 kg) and measures 4 ft (1.2 m) wide by 6 ft (1.8 m) long.
- c. Payload 2,000 lb up to 10,000 lb (907 kg to 4,535 kg).  
Typical sled: payload weight ratio, 2:1.
- 6a. 150 G with 500 lb (227 kg) payload. 107 G with 1,000 lb (454 kg).
- b. Typically  $230 \text{ G s}^{-1}$  for 10 G peak.
- c.  $169 \text{ ft s}^{-1}$  ( $51.5 \text{ m s}^{-1}$ ) to date.
- d. 8.4 ft (2.56 m)
- e. Trapezoidal, half sine, triangular, irregular.
- f. Peak G  $\pm 2\frac{1}{2}\%$ , velocity change  $\pm 2\frac{1}{2}\%$ .
- 7a. 50 channels, DC to 2,000 Hz.
- b. Flying lead plus telemetry for ECG.
- c. One accelerometer on sled and one on ram, 0-50 or 0-250 G. Two triaxial packages of piezoresistive accelerometers on dummy (in head and over sternum).
- d. Velocity. Harness loads with Lebow gauges and load cells.
8. 5th to 95th Mile Alderson  
95th Mile 'Dynamic Dan' (Sierra).
9. New harnesses are compared against current operational equipment. Tearing of webbing or amplification of loads at tie down points and breakage or jamming of hardware indicates failure of harnesses; fracture or gross distortion indicates failure of seats. Occupant failure indicated by exceeding acceleration limit criteria specified in MIL-S-9479B.
- 10.
11. See Shaffer, J.T. The Impulse Accelerator: An Impact Sled Facility for Human Research and Safety Systems Testing. AMRL-TR-76-8. Aerospace Medical Research Laboratories, Wright-Patterson AFB. (In press)

1. Ejection Tower  
Laboratory of Aerospace Medicine  
Centre d'Essais en Vol  
Brétigny-sur-Orge 91220, France.
2. Vertical ejection rig powered by ejection gun or rocket. Braking by gravity and elevator brake with ratchet.
3. 1955.
4. Tests on aircrew harnesses using dummies, and dynamic tests on ejection seats. Also tests on human and animal subjects.
- 5a. Tower 33 m tall.
  - b.
  - c.
- 6a. 40 G.
  - b.  $300 \text{ G s}^{-1}$ .
  - c.
  - d.
  - e. As produced by standard ejection systems.
  - f.
- 7a.
  - b.
  - c.
  - d.
8. 95%ile Alderson  
5%ile Alderson.
9. Excessive harness loads or failure.
- 10.
- 11.

- 17
1. Ejection Rig  
Royal Aircraft Establishment,  
Farnborough,  
Hants, UK.
  2. A standard ejection catapult fires an ejection seat up rails on near vertical tower. The carriage is braked by gravity and held from falling by a ratchet mechanism.
  - 3.
  4. Used for tests on ejection systems and on seat packs and cushions.
  - 5a. Tower 155 ft (47.2 m) tall inclined  $20^{\circ}$  from vertical.
    - b.
    - c.
  - 6a. About 20 G depending upon catapult charge.
    - b. Typically around  $300 \text{ G s}^{-1}$ .
    - c.  $95 \text{ ft s}^{-1}$  ( $20.9 \text{ m s}^{-1}$ ).
    - d.
    - e. Trapezoidal
    - f.
  - 7a. 11 channels frequency multiplexed on magnetic tape with analogue output on UV recorder. Frequency response from DC to 100 Hz, to DC to 1 kHz. All channels can be replayed with 20 Hz or 100 Hz filters.
    - b. Telemetry.
    - c. Smiths Industries variable reluctance type ALV 692 accelerometers and rate gyros, Shaevitz angular accelerometers.
    - d. Gun pressure by piezoelectric transducer. Harness loads by buckle strain gauges.
  8. 50%ile Anthony-Allen Mk 6 with chest cavity for instrumentation and ballast.
    - 5%ile Ogle.
    - 50%ile Ogle.
    - 95%ile Ogle.
  - 9.
  - 10.
  11. Recording facilities are duplicated in a mobile van used for air to ground telemetry of ejection data.

1. Vertical Accelerator  
6571st Aerospace Medical Research Laboratory,  
Air Force Systems Command,  
Holloman AFB,  
New Mexico.
2. Hyge 6 in accelerator (see Introduction, p. vi, for principle of operation).
- 3.
4. Used for human, animal and equipment tests.
- 5a.
- b.
- c. Maximum thrust of 40,000 lb (18.1 tonne).
- 6a. 150 G at 121 kg, 20 G at 2,000 lb (907 kg).
- b.
- c.
- d.
- e. Half sine, sawtooth and square wave. Trapezoidal of up to 40 G peak and 40 ms duration.
- f.
- 7a.
- b.
- c.
- d.
- 8.
- 9.
- 10.
11. Details and illustration in 'Principles of Biodynamics' AGARDograph No 150, p 67, 1971.

1. Vertical Impact Facility,  
Dept of Human Sciences,  
Loughborough University,  
England.
2. Two modes. 1, Hydraulic actuation from accumulator and quick acting valve to give vertical acceleration. Pulse shaping by accumulator volume and pressure, and ram travel. Braking at 1G or with added pneumatic braking. Ratchet to prevent subsequent fall. 2, Free fall on to hydraulic actuator or on to tear webbings to give longer duration impacts.
3. 1971.
4. Used for physiological and biodynamical research with dummies and human subjects.
- 5a. 6 m tall tower with 2 m of travel.
- b. Cage weighs 200 kg and measures 500 by 500 mm.
- c. Payload up to 100 kg. Takes seated subject. Typical sled : payload ratio = 3:1.
- 6a. Mode 1, 10 G; mode 2, 5 G max.
- b. About 5 ms to peak G, either mode.
- c.  $6 \text{ ms}^{-1}$ , either mode.
- d. Mode 1, 250 mm; mode 2, about 500 mm.
- e. Mode 1, ragged sawtooth; mode 2, trapezoidal pulse.
- f. Peak G repeatable within  $\pm 10\%$ .
- 7a. 7 channels, DC to 5 kHz.
- b. Flying lead.
- c. Wide range piezoelectric accelerometers on table, variable number of  $\pm 20$  G piezoresistive accelerometers on subject.
- d. Force applied to seat, using wide range piezoelectric transducer.
8. Mostly human subjects.
- 9.
- 10.
11. See Sandover, J. and Cole, S. (1974). Human response to impulsive forces. Final Report 1: Description of equipment. Laterg 105. University of Loughborough.  
Sandover, J. (1971). Measurement of human responses during impact. Paper A2 in AGARD Conference Proceedings No 88 on 'Linear Acceleration of Impact Type'. AGARD-CP-88-71.  
Rig can be angled  $25^\circ$  from vertical.

1. Centrifuge  
Laboratory of Aerospace Medicine  
Centre d'Essais en Vol  
Brétigny-sur-Orge 91220,  
France.
2. Centrifuge with rapid acceleration produced by a pneumatic motor capable of delivering a torque of 172 kNm, coupled to the centrifuge axle by cable and piston. Retardation by a central electro-hydraulic brake.
3. 1955.
4. Used for restraint and parachute harness tests with dummy and human subjects, and for physiological and biodynamical research.
- 5a. Centrifuge of 6 m radius.
  - b. Mass of arm with man-carrying gondola, 10,470 kg; with equipment gondola, 8,700 kg. Equipment gondola weighs 600 kg and measures 3.1 m long by 1.68 m wide.
  - c.
- 6a. 15 G with human subject; 40 G with equipment.
  - b.  $12.5 \text{ G s}^{-1}$  with human subject;  $33 \text{ G s}^{-1}$  with equipment.
  - c. Maximum tangential acceleration, 3.24 G with human subject, 5.47 G with equipment.
  - d.
  - e. Square wave.
  - f.
- 7a. 60 channels plus audio-visual monitoring of subjects.
  - b. Sliprings (120).
  - c. Mutual conductance accelerometers at the level of the centrifuge arm and dummy.
  - d.
8. 95%ile Alderson.  
5%ile Alderson.
9. Strain gauge measurement of harness loads. Physiological parameters. Cine-radiography.
- 10.
11. This device is also used as a conventional centrifuge powered by a 55 kw electric motor. See 'Principles of Biodynamics', AGARDograph No 150, 1971, pp 103-15.

1. Impact Sled Facility  
University of Michigan, Highway Safety Research Institute  
Ann Arbor,  
Michigan 48109, USA.
2. The sled is accelerated at up to 3G by a 10 ft (3.0 m) stroke pneumatic catapult, coasts for 35 ft (10.7 m) and rebounds in the impact area (see 11 below). After a further 10 to 20 ft (3.0 to 6.1 m) coast it is brought to rest by a dual pneumatic braking system.
3. February 1969.
4. Tests on seats and harnesses, physiological and biodynamical research; computation of Head Injury Criteria and Severity Indices.
- 5a. Track 60 ft (18 m) long.
- b. Sled weighs 975 lb (442 kg) and measures 6.5 ft (2.0 m) wide by 6.5 ft (2.0 m) long.
- c. Payload is 1,225 lb (556 kg) with allowable overhang. Typical sled/payload weight ratio, 11:1 to 7:1.
- 6a. 42 G at 1,200 lb (544 kg) to maximum 75 G.
- b.
- c. 65 mph (29.0 m s<sup>-1</sup>) at 1,200 lb (544 kg) to maximum of 75 mph (33.5 m s<sup>-1</sup>).
- d. Some 5½ ft (1.7 m).
- e. Square wave.
- f. Peak G ± 2%, velocity change ± 2%.
- 7a. 48 channels, 28 on FM tape and 20 on Honeywell 1612 oscilloscope. Hard wired to PDP 1145 for computation of HIC and SI values.
- b. Flying lead.
- c.
- d. 6 on-board and off-board cameras at up to 5,000 frames s<sup>-1</sup> (Millican, Photosonics, Hicam). Sled velocity, harness loads.
8. 95%ile Sierra male. '3 yr old' Sierra child.  
50%ile Sierra male (3) '6 yr old' Sierra child (2)  
5%ile Sierra female. 50%ile HSRI male.
- 9.
- 10.
11. The 'rebound decelerator' consists of a stationary horizontal cylinder measuring 18 in (460 mm) diameter by 36 in (914 mm) long and pressurised at up to 2,200 psig (15,170 kPa). It contains a 3½ in (92 mm) diameter piston which contacts the sled so imparting a constant (square wave) deceleration/acceleration pulse. Velocity change is 1.7 to 1.9 times entrance velocity.

1. Rebound Impactor  
Allied Chemical - Auto Products Division,  
Detroit,  
Michigan, USA.
2. Monterey design. A short track produces 2 to 3 G acceleration before sled impacts a rebound decelerator.
3. May 1969.
4. Tests on seats and restraint systems (belts and airbags) using dummies.
  - 5a. Track 30 ft (9.1 m) long.
  - b. Sled measures 4 ft (1.2 m) by 4 ft (1.2 m).
  - c. Payload of 600 lb (272 kg) may overhang sled.
  - 6a. 45 G at 600 lb (272 kg).
  - b.
  - c. 35 mph (15.6 m s<sup>-1</sup>) at 600 lb (272 kg).
  - d.
  - e. Half sine, haversine (rise time portion).
  - f. Peak G  $\pm$  2.5%, velocity change  $\pm$  2.5%.
  - 7a. 24 channels with 12 or more on magnetic tape.
    - b. Flying lead.
    - c. 2 accelerometers on 'adult' dummies.
    - d. Sled velocity, harness loads. On-board (to 40 G) and off-board cameras at up to 3,000 frames s<sup>-1</sup> (Stalex).
8. 95%ile Sierra male (3) )  
50%ile Sierra male (5) )  
5%ile Sierra female (2) ) Also used on Allied Chemical accelerator (see p. 4)  
'3 yr old' Sierra (2) )  
'6 yr old' Sierra ( )
- 9.
- 10.
- 11.

1. Rebound Impactor  
Southwest Research Institute  
San Antonio,  
Texas.
2. Rebound decelerator/accelerator includes an 800,000 lb (363 tonne) reaction mass.
- 3.
4. Tests on seats and restraint systems (including airbelts and airbags) using dummies, human subjects, animals (baboons) and cadavers. Also used for physiological and biodynamical research.
- 5a. Track 36 ft (11.0 m) long.
- b. Sled weighs 1,000 lb (454 kg) and measures 4 ft (1.2 m) wide by 6 ft (1.8 m) long.
- c. 3,000 lb (1,360 kg) and up to 8 ft (2.4 m) wide by 10 ft (3.0 m) long.
- 6a. 60 G at 1,000 lb (454 kg) total weight, 40 G at 2,000 lb (907 kg), 24 G at 4,000 lb (1,814 kg).
- b.
- c. 70 mph ( $31.3 \text{ m s}^{-1}$ ) at 1,000 lb (454 kg), 58 mph ( $25.9 \text{ m s}^{-1}$ ) at 2,000 lb (907 kg), 40 mph ( $17.9 \text{ m s}^{-1}$ ) at 4,000 lb (1,814 kg).
- d. 32 in (813 mm) using 16 in (406 mm) piston.
- f. Half sine, square, trapezoidal, triangular with duration up to 50 ms.
- 7a. 28 channels on magnetic tape.
- b. Flying lead.
- c.
- d. Sled velocity, harness loads, femur loads. On-board cameras (4 Photosonics). Off-board cameras to 3,000 frames  $\text{s}^{-1}$  (Hycam).
- 8.
9. Most tests to Federal Safety Standard MBSS 208.
- 10.
- 11.

1. Impact Decelerator  
National Aviation Facilities Experimental Centre  
Federal Aviation Agency,  
Atlantic City,  
New Jersey, USA.
2. Decelerator sled. A NAFEC design track produces 2-3 G acceleration over 90 ft (27.4 m) by pneumatic catapult, coast and subsequent deceleration using two (mark IV) hydraulic aircraft arresting engines. Barrier impacts also possible.
3. 1962.
4. Used for tests on aircraft seats with dummies.
- 5a. Track 300 ft (91 m) long.
- b.
- c. Payload up to 6,300 lb (2,860 kg).
- 6a. 70 G at 1,000 lb (454 kg), 20 G at 5,000 (2,270 kg), 15 G at 6,300 lb (2,860 kg).
- b.
- c. 61 mph ( $27.3 \text{ m s}^{-1}$ ) at 6,300 lb (2,860 kg).
- d. Up to 60 ft (18.3 m) using the arrestor cable.
- e. Triangular or irregular with barrier impact.
- f.
- 7a. Equipment borrowed as required.
- b.
- c.
- d.
8. 95%ile Alderson male (2)  
50%ile Alderson (3)  
5%ile Alderson (2)
- 9.
- 10.
- 11.

1. Impact Decelerator  
Institute for Motor Vehicles,  
Technical University of Berlin,  
W. Germany.
2. Sled accelerated by a falling weight impacted by plastic deformation of sheet metal strip or pneumatically.
3. July 1973.
4. Used for seat and harness testing and for research with human and dummy subjects.
- 5a. Track 11 m long.
- b. Sled weighs 200 to 800 kg and is 1.5 m wide by 2.0 m long.
- c. 150 kg, up to 2.0 m wide. Typical sled : payload ratio, 2:1 to 8:1.
- 6a.
- b.
- c.
- d.
- e. Approximate half-sine or rectangular.
- f. 'Very good'.
- 7a. 16 channels, DC to 400 Hz.
- b. Flying lead.
- c. Locally manufactured accelerometers of various ranges.
- d. Harness loads, high speed cine.
8. 3 Alderson 75%ile  
2 Alderson 'children aged 3 and 6 yr'  
1 Sierra 75%ile.
- 9.
- 10.
- 11.

1. Impact Decelerator  
Laboratory of Aerospace Medicine  
Centre d'Essais en Vol,  
Brétigny-sur-Orge 91220,  
France.
2. Simulator track. Sled guided by flanged rails and braked 'according to the nature of the test'.
- 3.
4. Used for tests on seats and harnesses with dummies, and tests on cargo restraint.
- 5a. Railway track (SNCF) of 2.5 m gauge, 600 m long.
- b.
- c.
- 6a. 50 G.
- b.
- c.
- d.
- e.
- f.
- 7a.
- b.
- c.
- d. High speed filming up to 900 frames s<sup>-1</sup>.
8. 95% Alderson  
5% Alderson.
9. Strain gauge measurement of restraint loads at attachment point.
- 10.
- 11.

1. Impact Deceleration Device  
Organisme National de Securite Routiere (ONSER),  
Laboratoire des Chocs et de Biomecanique, 109 Ave. Salvador Allende,  
69500 Bron,  
France.
2. Sled accelerated at a maximum of 1.5 G by flywheel stored energy, and braked, after a coast period of not less than 1.0 m, by driving metal olives into polyurethane cylinders (see p. 45).
3. 1969.
4. Used with dummies, animals (monkeys) and cadavers for biodynamic research and design of restraint systems - children's seats, belts, airbags.
- 5a. 21 m long.
- b. Sled weighs 80 or 420 kg and measures 0.95 m wide by 1.70 m long.
- c. 300 kg with light sled. Up to 0.95 m x 1.70 m.  
Typical sled : payload weight ratio, 5:1.
- 6a.
- b. Typically 20 ms to 30 G (ECE Regulation 16, see p. 45).
- c. 70 km h<sup>-1</sup> (19.4 m s<sup>-1</sup>), but up to 100 km h<sup>-1</sup> (27.8 m s<sup>-1</sup>) with 200 kg total load.
- d. Up to 1.0 m.
- e. Trapezoidal. 20 ms to 30 G at 50 km h<sup>-1</sup> entry velocity (ECE 16).
- f. Impact velocity repeatable to 1%. Deceleration affected by ageing properties of the polyurethane cylinders.
- 7a. 24 channels. Up to 10 kHz using flying lead. IRIG standard using telemetry and FM magnetic tape recording.
- b. Flying lead and/or telemetry.
- c. 1 or 2 piezoresistive  $\pm 50$  or  $\pm 100$  G accelerometers at sled C of G. Variable number on dummy, piezoresistive  $\pm 20$  to  $\pm 500$  G.
- d. Sled velocity and stopping distance (optico-electronic technique). Load measurements.
8. 50% adult  
'8 yr old' boy.
- 9.
10. Increased number of recording channels (to 36 and 48).  
Improved building and device with 100 km h<sup>-1</sup> (27.8 m s<sup>-1</sup>) performance at 1,200 kg payload.
11. See 'Effectiveness of Safety Belts under Various Directions of Crashes'.  
Cesari, D., R. Quinay and Y. Derrien. Paper 720973, Proceedings of the 16th Stapp Car Crash Conference (1972).

1. Large-scale Impact Machine  
Safety in Mines Research Establishment,  
Field Laboratories,  
Buxton,  
Derbyshire, England.
2. A 'specimen' truck and a 'hammer' truck run on inner and outer rails of a four-rail track. The track rises at either end and the trucks can be released at any heights to collide on a central level section of track.
3. 1963.
4. Impact testing of large metal components.
- 5a. 265 m long track rising 30 m at one end, 12 m at the other.
- b. Hammer trucks weigh either 1 to 2 tonne, or 5 tonne. Specimen truck weighs 9 tonne.
- c. Wire ropes up to 50 mm in diameter and 1.5 m long, or hooks of up to 200 kN safe working load.
- 6a. Maximum available energy is at least 0.73 MJ.
- b.
- c. Theoretical maximum (30 m descent) of  $24 \text{ m s}^{-1}$ .
- d.
- e. Indeterminate. Specimens typically take 30 ms to failure.
- f.
- 7a. U.V. recorder. Digital read-out of impact energy.
- b. Overhead travelling cable.
- c.
- d. Metal foil strain gauges mounted on specimen loading pins, and an optico-electronic extensometer.
- 8.
- 9.
- 10.
11. See SMRE Digest, Engineering and Metallurgy, Nos 1 and 7, 1972; and No 2, 1973.

1. Impact Decelerator  
General Motors - Inland Division  
Dayton,  
Ohio, USA.
2. Crash barrier decelerator with compressed air for initial acceleration phase.
3. 1971.
4. Used for harness tests with dummies.
- 5a. Track 15 ft (4.6 m) long.  
b.  
c. Payload 2,500 lb (1,135 kg).
- 6a.  
b.  
c. 34 mph (15.2 m s<sup>-1</sup>).  
d.  
e. 'variable'.  
f.
- 7a. 32 channels on magnetic tape.  
b.  
c.  
d.
8. 50%ile G.M. Hybrid II, female.  
95%ile G.M. Hybrid II, male.  
'6 yr old' G.M. Hybrid II.
- 9.
- 10.
- 11.

1. Wham III Decelerator Sled  
Wayne State University,  
Detroit,  
Michigan, USA.
2. Sled accelerated over 72 ft (21.9 m), then coasts before impacting a hydraulic snubber.  
Can also be used for barrier crashes.
3. January 1972.
4. Used for tests on seats, harnesses and vehicles, and for physiological and biodynamical research with dummies, human subjects, animals and cadavers.
- 5a. Track 150 ft (45.7 m) long.
- b. Sled weighs 1,500 lb (680 kg) and measures 12 ft (5.4 m) wide by 15 ft (6.8 m) long.
- c. 4,000 lb (1,815 kg).
- 6a. 50 G at 2,500 lb (1,135 kg)
- b.
- c. 60 mph (26.8 m s<sup>-1</sup>) at 2,500 lb (1,135 kg).
- d. Up to 6 ft (1.83 m).
- e. Half sine, square, skewed, triangular, or irregular.
- f. Velocity change within  $\pm 0.2$  mph at 30 mph ( $\pm 0.7\%$ ).
- 7a. 58 channels on tape.
- b. Flying lead.
- c.
- d. 4 cameras, on and off-board at up to 2,000 frames s<sup>-1</sup>.
8. 50%ile Alderson (2)  
50%ile Sierra (2)  
95%ile Sierra male  
'6 yr old' (48 lb, 21.8 kg) child dummy.
- 9.
- 10.
- 11.

1. Wham II Decelerator Sled,  
Wayne State University,  
Detroit,  
Michigan, USA.
2. Sled accelerated over 6 ft (1.83 m) by winch (Flywheel stored energy transferred to winch drum by clutch). Can also be used for barrier impacts.
3. 1968.
4. As for Wham III (see p. 30).
- 5a. Track 150 ft (45.7 m) long.
  - b.
  - c. 2,000 lb (910 kg).
- 6a. 50 G at 2,000 lb (910 kg).
  - b.
  - c. 40 mph ( $17.9 \text{ m s}^{-1}$ ) at 2,000 lb (910 kg).
  - d.
  - e. Half sine, square skewed, irregular.
  - f.
- 7a. 58 channels on tape.
  - b. Flying lead.
  - c.
  - d. Cameras as for Wham III (p. 30). Velocity, harness loads.
8. As for Wham III (p. 30).
- 9.
- 10.
- 11.

1. Wham I Decelerator Sled  
Wayne State University,  
Detroit,  
Michigan, USA.
- 2.
3. 1963.
4. As for Wham III.
- 5a. Track 15 ft (4.6 m) long.
  - b.
  - c. 300 lb (136 kg).
- 6a. 50 G at 300 lb (136 kg).
  - b.
  - c. 30 mph ( $13.4 \text{ m s}^{-1}$ ) at 300 lb (136 kg)
  - d.
  - e.
  - f.
- 7a. 30 channels on tape.
  - b. Flying lead.
  - c.
  - d. Cameras as for Wham III (p. 30). Velocity, harness loads.
8. As for Wham III (p. 30).
- 9.
- 10.
- 11.

1. Linear Decelerator  
Royal Air Force Institute of Aviation Medicine,  
Farnborough,  
Hampshire, England.
2. Stretched rubber bungee cords accelerate sled over 26 m. Sled coasts for 13 m before being arrested by hydraulic energy dissipators.
3. June 1973.
4. Seat and harness testing with dummies. Physiological and biodynamical research with human subjects.
- 5a. 46 m long track.
- b. 400 kg, 0.9 m wide by 4.0 m long.
- c. 250 kg, 3.0 m wide by 3.0 m long (depending on acceptable overhang).  
Maximum all up weight of vehicle, 682 kg.
- 6a. 50 G.
- b. 1,000 G sec<sup>-1</sup>, but unlimited.
- c. 15.2 m s<sup>-1</sup>.
- d. 0.9 m.
- e. Half sine.
- f. Impact velocity  $\pm$  0.25%. Peak G  $\pm$  1%.
- 7a. 14 channels, DC to 200 Hz on magnetic tape.  
12 channels, DC to 60 Hz on UV recorder.
- b. Flying lead.
- c. G<sub>x</sub> on sled c of g. Triaxial mount on bite plate. Triaxial mount over spine of vertebra C7.
- d. High speed filming, impact velocity, harness loads, tension loads in seat structure.
8. 95%ile and 50%ile Sierra.  
RAE Mk V rubber block dummy.  
Human volunteers.
9. Failure has occurred if seat allows secondary collision of dummy with the most prominent cockpit structure.
10. Increased payload.
11. See Giles, A.F. (1971). A Linear deceleration track. Paper B2 in AGARD Conference Proceedings No 88 on 'Linear Acceleration of Impact Type'. AGARD-CP-88-71.  
Dutton, D. (1974). A versatile Linear Decelerator Track. Tech. Memo. No. 360. RAF Institute of Aviation Medicine, Farnborough, Hants.

1. Impact Catapult (Katapultenlage für Aufprallversuche),  
Batelle - Institut c.V.  
Frankfurt am Main,  
W. Germany.
2. Sled accelerated over 6 m by 3 bungee cables coasts for 2 m and impacts a steel strip which is deformed between rollers (see illustration below).
- 3.
- 4.
- 5a. Track 11 m long.
- b. Sled weighs 140 kg and measures 850 mm wide by 2.9 m long.
- c. Car body parts, typically 280 kg and measuring 1.7 x 3.0 m.
- 6a. 40 G to date.
- b.  $2,500 \text{ G s}^{-1}$ .
- c.  $70 \text{ km h}^{-1}$  ( $19.5 \text{ m s}^{-1}$ );  $50 \text{ km h}^{-1}$  ( $14 \text{ m s}^{-1}$ ) with heavy sled.
- d. 800 mm.
- e. As described in ECE Regulation 16 (see p. 45).
- f. Velocity  $\pm 1 \text{ km h}^{-1}$  ( $\pm 0.3 \text{ m s}^{-1}$ ); mean deceleration  $\pm 2 \text{ G}$ .
- 7a. UV recorder and FM tape to SAE J211 and J211a (see Introduction, p.vii).
- b. Flying lead.
- c.
- d. High speed cine up to  $5,000 \text{ frames s}^{-1}$  (Hycam).  
Forces, travel, contact pressure.
8. 50%ile Sierra (2) '6 yr old' TNO  
95%ile Sierra '3 yr old' Sierra  
50%ile Alderson '6 kg baby' Spielzeugpuppe  
'10 yr old' Ogle-Mira

9.

10.

11.

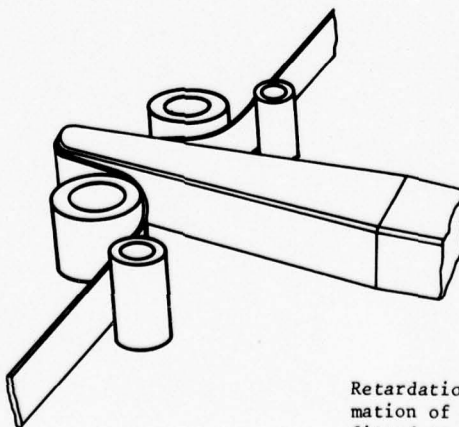

Retardation is achieved by permanent deformation of a flat steel strip with a spike fitted to the front of the sled.

1. Deceleration Sled  
Institute of Medical Jurisprudence,  
University of Heidelberg,  
W. Germany.
2. A sled is accelerated along a track by a falling weight to impact a strip of sheet metal which is plastically deformed.
3. December 1972.
- 4.
- 5a. 24 m long track.
  - b. Sled weighs 500 kg and measures 1.4 m wide by 3.0 m long.
  - c. 100 kg. Typical sled : payload ratio, 5:1.
- 6a. 40 G.
  - b.
  - c.  $100 \text{ km h}^{-1}$  ( $27.8 \text{ m s}^{-1}$ ).
  - d.
  - e.
  - f.
- 7a.
  - b. Flying lead.
  - c. One 100 G Wazau accelerometer on sled, one similar accelerometer on head of dummy or cadaver.
  - d.
8. Human cadavers.  
50%ile Sierra.
- 9.
- 10.
- 11.

1. DAISY Decelerator,  
New Mexico State University,  
Holloman AFB,  
New Mexico.
2. Pneumatic piston accelerates sled over 42 ft (12.8 m). Sled coasts for 80 or 180 ft (24.4 or 54.9 m) and is decelerated by a 4 ft (1.2 m) piston entering a water filled cylinder.
3. 1955.
4. Seat, harness and vehicle testing, physiological and biodynamical research using dummies, human and animal subjects, and cadavers.
- 5a. 220 ft (67.1 m) track.
- b. 465 to 4,830 lb (211 to 2,192 kg), 61 in (1.55 m) wide, 15 ft (4.6 m) long.
- c. 250 to 1,000 lb (113 to 454 kg), 61 in (1.55 m) wide, 91 in (2.31 m) long.  
Typical sled : payload ratio, 2:1 to 4:1.
- 6a. 80 G for 500 lb (227 kg) payload, 25 G for 1,000 lb (454 kg) payload.
- b. 50 to 1,500  $G s^{-1}$ .
- c. 175  $ft s^{-1}$  (53.3  $m s^{-1}$ ).
- d. 4 ft (1.22 m).
- e. Rectangular, half sine, triangular or irregular.
- f. Impact velocity  $\pm 7\%$ , peak G  $\pm 10\%$ .
- 7a. 44 channels, DC to 500 Hz.
- b. Flying lead.
- c. On sled behind piston and two sites on payload platform. Triaxial packages in dummy head and over area of sternum.
- d. Peak sled velocity, impact velocity, sled displacement during deceleration, harness loads, body segment motion.
8. 5th to 95th Zile Alderson and Sierra.
9. Tearing of harness, amplification of loads at tie-down points, breaking or jamming of hardware. Fracture or gross distortion of seat structure. Exceeding acceleration limit criteria laid down in MIL-S-9479B.
- 10.
11. For a 10 G pulse and rectangular waveform a rise time of 7 ms, dwell of 140 ms and offset time of 45 ms would be typical. A triangular pulse would typically have a rise time of 105 ms and offset time of 200 ms.  
The facility at Holloman AFB is leased from the US Air Force by the State University of New Mexico. See Chandler, R.F. (1967). The Daisy Decelerator. ARL-TR-67-3. Aeromedical Research Laboratory, Air Force Systems Command, Wright-Patterson AFB, Ohio.  
There is a 'Bopper Crash Restraint Demonstrator' at Holloman, capable of decelerating human subjects from 6.1  $m s^{-1}$  at 25 G, and used for indoctrination of subjects and development of techniques for the Daisy decelerator.

1. Vehicle Impact Test Facility  
Motor Industry Research Association  
Lindley, Nuneaton,  
Warks, England.
2. Linear induction motor accelerates sled test vehicle into impact area containing target.
3. March 1968.
4. Vehicle impacts against fixed or movable barriers, other vehicle or obstacle.  
Rollover crashes may be performed.
- 5a. 170 ft (51.8 m) track.
- b. No sled is used.
- c. Vehicles up to 10,000 lb (4,536 kg), 17 ft (5.2 m) wide. Length unlimited.
- 6a. Indeterminate.
- b. Indeterminate.
- c. 40 mph ( $17.9 \text{ m s}^{-1}$ ).
- d. Indeterminate.
- e. Complex depending upon type of vehicle and barrier used.
- f. Impact velocity usually  $\pm 1\%$ .
- 7a. 65 channels, DC to 10 kHz on magnetic tape.  
65 channels, DC to 2 kHz on paper.  
Up to 65 accelerometers with ranges of up to  $\pm 500 \text{ G}$ .
- b.
- c.
- d. High speed filming, harness and skeletal loads, displacements, contact timing, pressures, impact velocity, barrier face loads.
8. 50%ile, MIRA/OGLE, Alderson and Sierra.  
95%ile male Sierra.  
RAE Mk Vb.
9. Depends on customer's requirements.
10. Increased impact velocity. Use of facility for human subjects.
11. See Aston, T.R. (1971). The MIRA vehicle impact test facility. Paper B5 in AGARD Conference Proceedings No 88 on 'Linear Acceleration of Impact Type'. AGARD-CP-88-71.

1. Short Track  
Civil Aeromedical Institute  
Federal Aviation Agency - Protection and Survival Laboratory,  
Oklahoma City,  
Oklahoma, USA.
2. Sled, accelerated by falling 3,000 lb (1,361 kg) weight acting through block and tackle system, is impacted against a C 47 landing wheel hydraulic brake attached by cable to a stop on which are mounted calibrated formed lead cones.
3. November 1963.
4. Used to test crashworthiness of seats and harnesses in light civil aircraft, with dummies and animal subjects.
- 5a. Track 150 ft (45.7 m) long.
- b. Sled weighs 860 lb (390 kg) and measures 5 ft (1.5 m) wide by 8 ft (2.4 m) long.
- c. 1,400 lb (635 kg) within dimensions of sled.
- 6a. 30 G at 1,400 lb (635 kg).
- b.
- c. 40 mph ( $17.9 \text{ m s}^{-1}$ ) at 1,400 lb (635 kg).
- d. 20 ft (6.1 m).
- e. Triangular and trapezoidal.
- f. Peak G  $\pm$  2%, velocity change better than  $\pm$  1%.
- 7a. 44 channels, DC to 1,000 Hz on tape.
- b. Flying lead.
- c. One accelerometer on sled.
- d. Up to 8 high speed cameras (to 1,000 frames  $\text{s}^{-1}$ ).
8. 95%ile Alderson male (6)  
50%ile Alderson male (1)  
5%ile Sierra female (1)  
'6 yr old' (2)  
'3 yr old' (1)
9. Failure of hardware, or excessive slippage of harness. Structural failure, or excessive occupant loads. Gadd severity index, Head Injury Criteria, HSRI Head Injury Strain Criteria.
- 10.
11. Details of this and associated FAA impact facilities - Drop Test Apparatus, used for ship-shock studies with 12 ft (3.65 m) free fall: Vertical Decelerator, used for ejection system tests and having a 40 ft (12.2 m) tall tower: Impact Bopper, used for aircraft crash tests on cadaver specimens and similar in construction to that at Holloman AFB (p.36) - may be found in 'Principles of Biodynamics', AGARDograph No 150, pp.73-75, 1971.

1. Impact Decelerator  
Dynamic Science  
Phoenix,  
Arizona, USA.
2. Sled accelerated by falling mass in 90 ft (27.4 m) tall tower to impact a block of crushable material or extrusion straps.
3. 1964.
4. Tests on aircraft seats and harnesses using dummies.
- 5a. Track 70 ft (21.3 m) long.
- b. Sled weighs 2,000 lb (907 kg) and measures 6 ft (1.8 m) wide by 8 ft (2.4 m) long.
- c. 1,000 lb (454 kg). No overhang available.
- 6a. 60 G.
- b.
- c. 34 mph ( $15.2 \text{ m s}^{-1}$ ) at 3,000 lb (1,360 kg) total weight.
- d.
- e. Square, triangular, trapezoidal.
- f. Peak G  $\pm$  5%, using paper honeycomb impact energy absorption.  
Impact velocity  $\pm$  5%.
- 7a. 120 channels on magnetic tape, frequency response to 1 kHz.
- b.
- c. 2 accelerometer positions on sled.
- d. Sled velocity, harness loads.
8. 50%ile Alderson male with G.M. necks (7).
- 9.
10. Track to be extended to 160 ft (48.8 m).
11. The 90 ft (27.4 m) tower can also be used as a drop test facility.

1. Impact Decelerator  
Italian Air Force  
Study and Research Centre of Aviation and Space Medicine  
Rome, Italy.
2. A sled, running on two parallel rows of ball bearings, is accelerated by pre-stretched elastic ropes, to impact against moulded lead buffers or 4 air containing cylinders fitted with pistons.
- 3.
4. Used for experiments on dummies or animals.
- 5a.
- b.
- c.
- 6a. 'Many thousand' G.
  - b.
  - c.
  - d.
  - e.
  - f.
- 7a. 14 channels on a CRO or UV recorder.
  - b.
  - c.
  - d. High speed cine up to 3,000 frames s<sup>-1</sup>.
- 8.
- 9.
- 10.
11. See 'Principles of Biodynamics'. AGARDograph No 150, pp. 108-109. 1971.

1. Vehicle Acceleration Apparatus  
Daimler-Benz AG  
7032 Sindelfingen,  
W. Germany.
2. Test vehicle accelerated by linear motor (Siemens) developing 53 kN over 32 m track then coasts for 33 m prior to impact against concrete barrier weighing 1,000 tonne.
3. January 1973.
4. Crash tests on passenger and commercial vehicles.
- 5a. Track 65 m long.
- b. No sled is used.
- c. 10,000 kg, no dimensional limitations.
- 6a. Depends on impact surface and vehicle dynamics.
- b. " " " " " " " "
- c.  $90 \text{ km h}^{-1}$  ( $25.0 \text{ m s}^{-1}$ ) for 2,000 kg;  $50 \text{ km h}^{-1}$  ( $13.9 \text{ m s}^{-1}$ ) for 10,000 kg vehicle.
- d. Depends on impact surface and vehicle dynamics.
- e. " " " " " " " "
- f. Velocity within 1% over range 8 to  $90 \text{ km h}^{-1}$  ( $2.2$  to  $25.0 \text{ m s}^{-1}$ ).
- 7a. FM tape to SAE J211b (see Introduction, p.vii). Test signal accurate to  $\pm 3\%$ .
- b. Flying lead.
- c. Force and acceleration transducer in vehicle and on dummy.
- d. High speed filming with high level illumination (100,000 lux).
- 8.
- 9.
10. Planned extension of acceleration track and new crash barrier will increase performance to permit impact of 26,000 kg commercial vehicle at  $50 \text{ km h}^{-1}$ .
11. After decoupling of test vehicle, linear motor is braked by counter-torque for velocities of up to  $65 \text{ km h}^{-1}$  ( $18.1 \text{ m s}^{-1}$ ) (max. retardation force of 64 kN). Mechanical brakes are used in addition at higher speeds and in emergency (max. retardation of 210 kN).

1. Impact Decelerator  
Auto Avia Laboratories, FIAT  
Corso Marconi 10/20,  
Turin 10125, Italy.
2. 30 bungees, 20 m long, and stretched to 50 m, act via coil springs, hawser and trolley to accelerate the test vehicle at 2.5 G to 10 G. There is a coast period of 5 to 6 m prior to barrier impact. The trolley can also carry body shells and be braked hydraulically, or by the use of other energy absorbing devices.
- 3.
4. Tests on dummies in whole cars or on a sled mounted seat.
- 5a. 56.5 m long track.
- b.
- c. Cars up to 2,000 kg.
- 6a. Indeterminate.
- b. "
- c.  $80 \text{ km h}^{-1}$  ( $22.2 \text{ m s}^{-1}$ ).
- d. Depends upon crush of test vehicle.
- e.
- f.
- 7a.
- b.
- c.
- d. High speed cine and video tape.
- 8.
- 9.
- 10.
11. See Franchini, E. (1971). Fiat catapults. Paper B4 in AGARD Conference Proceedings No 88 on 'Linear Acceleration of Impact Type', 1971.

1. Impact Test Facility,  
Manned Spacecraft Centre,  
National Aeronautics and Space Administration,  
Houston, Texas.
2. Drop tower with piston entering a water filled perforated cylinder.
- 3.
4. Used for simulating spacecraft impact conditions.
- 5a. Drop height up to 23 ft (7.0 m).
- b.
- c. 2,000 lb (907 kg) payload.
- 6a. 100 G.
- b.  $10,000 \text{ G s}^{-1}$ .
- c.  $38 \text{ ft s}^{-1}$  ( $11.6 \text{ m s}^{-1}$ ).
- d.
- e. Half sine, versine, triangular, trapezoidal.
- f.
- 7a. 40 channel low-level data acquisition system.
- b.
- c.
- d.
- 8.
- 9.
- 10.
11. Waveform is controlled by a mechanically variable orifice predefined by computer programme.  
See 'Principles of Biodynamics'. AGARDograph No 150, pp. 71 and 92, 1971.

1. Vertical Decelerator.  
6570th Aerospace Medical Research Laboratories,  
Air Force Systems Command,  
Wright-Patterson AFB,  
Ohio, USA.
2. Freefall onto a plunger and water filled cylinder.
3. 1962.
4. Used for tests on seats, harnesses and vehicles and for physiological and biodynamical research with dummies, animals and human subjects.
- 5a. Tower 50 ft (15.2 m) tall.
- b. Carriage weighs 2,000 lb (907 kg) and measures 36 in (0.9 m) wide by 81 in (2.1 m) tall.
- c. 2,000 lb (907 kg) measuring 36 in (0.9 m) wide by up to 72 in (1.8 m) tall.
- 6a. 80 G for 500 lb (227 kg) payload, 65 G for 1,000 lb (454 kg).
- b. Typically 20 ms to 10 G for triangular pulse.
- c.  $56 \text{ ft s}^{-1}$  ( $17.1 \text{ m s}^{-1}$ ).
- d. 4 ft (1.2 m).
- e. Triangular and half sine.
- f. Peak G  $\pm$  7.5%, velocity change  $\pm$  7.5%.
- 7a. 14 channels DC to 128 Hz, 44 channels DC to 800 Hz.
- b. Flying lead.
- c. One accelerometer (10-50 G range) on carriage. Two triaxial packages of piezoresistive accelerometers within dummy head and over area of sternum.
- d. Sled velocity measured by interrupted light beam.
8. 5th to 95th Sierra and Alderson dummies. 'Dynamic Dan' used to evaluate energy attenuating seats.
9. New harnesses are tested comparatively against current operational items. Tearing of webbing or amplification of loads at harness tie-down points, and breakage or jamming of hardware indicate failure. Seat failure indicated by fracture or gross distortion of structure. Occupant failure by exceeding MIL-S-9479B.
10. Slide blocks in place of rollers to reduce vibration of carriage at impact.
11. See 'Principles of Biodynamics'. AGARDograph No 150, pp. 65-67. 1971.

1. Impact Deceleration Standard.  
United Nations Agreement, Regulation 16.
2. A trolley is decelerated by a pair of energy absorbing devices each comprising a polyurethane tube in an outer steel casing through which is driven an olive shaped steel knob (see figure at foot of page). The mode of accelerating the trolley prior to impact is left to the user.
3. May 1973.
4. To be used for standardised testing of seat belts for adult occupants of power-driven vehicles.
- 5a. Track not detailed.
- b. Sled to weight  $400 \pm 20$  kg ( $880 \pm 44$ lb). Dimensions not detailed.
- c. Dummy to weigh  $74.5 \pm 1.0$  kg.
- 6a. See adjacent figure.
- b. " " "
- c.  $50 \pm 1$  km h<sup>-1</sup> ( $30 \pm 0.6$  mph,  $13.9 \pm 0.3$  m s<sup>-1</sup>)
- d.  $40 \pm 5$  cm ( $15.8 \pm 2$  in).
- e. See adjacent figure.
- f. " " "
- 7a.
- b.
- c.
- d.
8. Agreed manikin as detailed in Annex 7 to Regulation 16.
9. 'The belt assembly shall not break and the buckle shall not open; and the forward displacement shall be between 100 mm (4 in) and 200 mm (8 in) at pelvic level in the case of lap belts and between 200 mm (8 in) and 300 mm (12 in) at chest level in the case of other types of belt, this displacement being the displacement in relation to the reference points shown in Annex 7 to Regulation 16.'
- 10.
11. See E/ECE/324 )  
E/ECE/TRANS/505 ) Rev.1/add 15/rev.1.

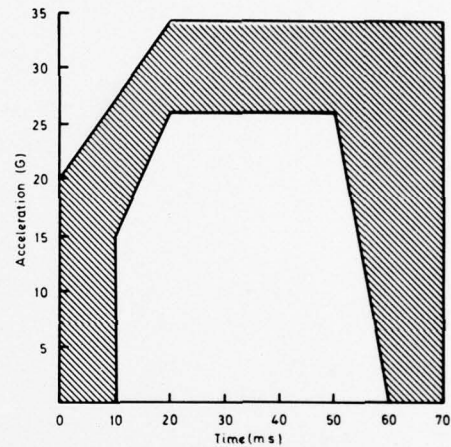

ECE Regulation No 16.  
The deceleration curve of the sled weighted with inert mass to a total of  $455^{+20}$ kg must remain within the shaded area.

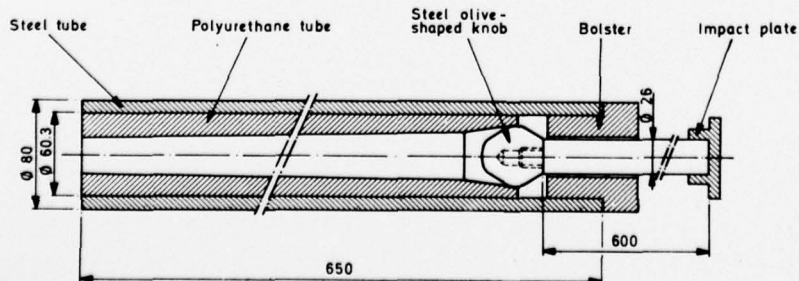

Stopping device recommended in ECE Regulation No 16, though any device giving identical results (see figure above) would be accepted.

1. Title and location of facility
  
2. Principle of operation
  
3. Date facility became operational
  
4. Main use and type of test
  
- 5a. Details: Length of track (height of tower)
- b. Weight, width and length of sled
- c. Weight, width and length of payload
  
- 6a. Performance: Maximum acceleration
- b. jolt
- c. velocity change
- d. stroke
- e. Waveform
- f. Repeatability
  
- 7a. Instrumentation: Number of channels, method of recording and frequency response
- b. Method of signal transmission
- c. Type, range and siting of accelerometers
- d. Other parameters monitored
  
8. Subject/dummy inventory
  
  
  
  
  
  
  
  
  
  
9. Criteria for harness or seat failure
  
  
  
  
  
  
  
  
  
  
10. Planned improvements
  
  
  
  
  
  
  
  
  
  
11. Other details and references

**NOTE**

**FOLD OUT THIS FLAP TO  
USE WITH PAGES 1 TO 45.**

	Page
Aerospace Medical Research Department	11
6570th Aerospace Medical Research Laboratories	15, 44
6571st Aerospace Medical Research Laboratory	18
Allied Chemical - Auto Products Division	4, 22
American Safety Equipment	7
Auto Avia Laboratories	42
Battelle Institut	34
Bayerische Motoren Werke	9
Calspan	1
Centre d'Essais en Vol de Brétigny	16, 20, 26
Centro di Studi e Ricerche di Medicina Aeronautica e Spaziale	42
Chrysler - Proving Ground Section	2
Civil Aeromedical Institute (FAA)	38
Cornell Aerospace Laboratories	1
Daimler-Benz AG	13, 41
Dynamic Science	39
Eaton Corporation - Research Centre	14
Federal Aviation Agency	24, 38
Fiat	42
Ford - Safety and Service Product Development Group	3
French Air Force	16, 20, 26
General Motors	8, 29
Highway Safety Research Institute	21
Holloman Air Force Base	36
Institute of Aviation Medicine (RAF)	33
Institut für Medizinische Jurisprudence	35
Institut für Kraftfahrzeuge	25
Italian Air Force	40
Laboratoire de Médecine Aérospatiale	16, 20, 26
Laboratoire des Chocs et de Biomecanique (ONSER)	27
Manned Spacecraft Center (NASA)	43
Max-Planck-Institut für Arbeitsphysiologie	5
Michoud Station (NAMRL)	10
Motor Industry Research Association	37
National Aeronautics and Space Administration	43
National Aviation Facilities Experimental Center	24
National Highway Transport Safety Association	12
Naval Aerospace Medical Research Laboratory	10
Organisme National de Securite Routiere	27
Royal Aircraft Establishment	17
Royal Air Force Institute of Aviation Medicine	33
Safety in Mines Research Establishment	28
Southwest Research Institute	23
State University of New Mexico	36
Technischen Universität, Berlin	25
United Nations Agreement	45
United States Air Force	15, 18, 44
United States Navy	11
University of Heidelberg	35
University of Michigan	21
University of Technology, Loughborough	19
Wayne State University	30, 31, 32
Wright-Patterson Air Force Base	44

REPORT DOCUMENTATION PAGE												
<b>1. Recipient's Reference</b>	<b>2. Originator's Reference</b>	<b>3. Further Reference</b>	<b>4. Security Classification of Document</b>									
	AGARD-R-658	ISBN 92-835-1256-1	UNCLASSIFIED									
<b>5. Originator</b>	Advisory Group for Aerospace Research and Development North Atlantic Treaty Organization 7 rue Ancelle, 92200 Neuilly sur Seine, France											
<b>6. Title</b>	A CATALOGUE OF CURRENT IMPACT TEST DEVICES											
<b>7. Presented at</b>												
<b>8. Author(s)</b>	Edited by D.H.Glaister		<b>9. Date</b>									
			September 1977									
<b>10. Author's Address</b>	RAF Institute of Aviation Medicine Farnborough, UK		<b>11. Pages</b>									
			110									
<b>12. Distribution Statement</b>	This document is distributed in accordance with AGARD policies and regulations, which are outlined on the Outside Back Covers of all AGARD publications.											
<b>13. Keywords/Descriptors</b>	<table> <tbody> <tr> <td>Impact tests</td> <td>Seats</td> <td>Acceleration (physics)</td> </tr> <tr> <td>Biodynamics</td> <td>Straps</td> <td>Test facilities</td> </tr> <tr> <td>Helmets</td> <td>Loads (forces)</td> <td>Standard operating procedures</td> </tr> </tbody> </table>			Impact tests	Seats	Acceleration (physics)	Biodynamics	Straps	Test facilities	Helmets	Loads (forces)	Standard operating procedures
Impact tests	Seats	Acceleration (physics)										
Biodynamics	Straps	Test facilities										
Helmets	Loads (forces)	Standard operating procedures										
<b>14. Abstract</b>	<p>↘ This report is the result of a Working Group set up in 1972 under the auspices of NATO/AGARD Aerospace Medical Panel to consider the standardisation of biodynamic impact testing with special reference to helmets, seats and harnesses. Helmets were considered separately (Agard Report No. 629). This report is based on replies to questionnaires sent to research laboratories, and catalogues 52 impact test devices. They are listed according to the operating organisations, and classified by principle of operation (accelerators, decelerators, horizontal, vertical etc). Details of construction, performance and use of each facility are given. Also described are some current standards for crash impact testing and the principles of operation of the more common types of test devices. ←</p> <p>This Report was prepared at the request of the Aerospace Medical Panel of AGARD.</p>											

<p>AGARD Report No.658 Advisory Group for Aerospace Research and Development, NATO A CATALOGUE OF CURRENT IMPACT TEST DEVICES Published September 1977 110 pages (of which 62 are printed)</p> <p>This report is the result of a Working Group set up in 1972 under the auspices of NATO/AGARD Aerospace Medical Panel to consider the standardisation of bio-dynamic impact testing with special reference to helmets, seats and harnesses. Helmets were considered separately (Agard Report No.629). This report is based on replies to questionnaires sent to research laboratories, and catalogues 52 impact test devices.</p> <p>P.T.O.</p>	<p>AGARD-R-658</p> <p>Impact tests Biodynamics Helmets Seats Straps Loads (forces) Acceleration (physics) Test facilities Standard operating procedures</p>	<p>AGARD Report No.658 Advisory Group for Aerospace Research and Development, NATO A CATALOGUE OF CURRENT IMPACT TEST DEVICES Published September 1977 110 pages (of which 62 are printed)</p> <p>This report is the result of a Working Group set up in 1972 under the auspices of NATO/AGARD Aerospace Medical Panel to consider the standardisation of bio-dynamic impact testing with special reference to helmets, seats and harnesses. Helmets were considered separately (Agard Report No.629). This report is based on replies to questionnaires sent to research laboratories, and catalogues 52 impact test devices.</p> <p>P.T.O.</p>	<p>AGARD-R-658</p> <p>Impact tests Biodynamics Helmets Seats Straps Loads (forces) Acceleration (physics) Test facilities Standard operating procedures</p>
<p>AGARD Report No.658 Advisory Group for Aerospace Research and Development, NATO A CATALOGUE OF CURRENT IMPACT TEST DEVICES Published September 1977 110 pages (of which 62 are printed)</p> <p>This report is the result of a Working Group set up in 1972 under the auspices of NATO/AGARD Aerospace Medical Panel to consider the standardisation of bio-dynamic impact testing with special reference to helmets, seats and harnesses; Helmets were considered separately (Agard Report No.629). This report is based on replies to questionnaires sent to research laboratories, and catalogues 52 impact test devices.</p> <p>P.T.O.</p>	<p>AGARD-R-658</p> <p>Impact tests Biodynamics Helmets Seats Straps Loads (forces) Acceleration (physics) Test facilities Standard operating procedures</p>	<p>AGARD Report No.658 Advisory Group for Aerospace Research and Development, NATO A CATALOGUE OF CURRENT IMPACT TEST DEVICES Published September 1977 110 pages (of which 62 are printed)</p> <p>This report is the result of a Working Group set up in 1972 under the auspices of NATO/AGARD Aerospace Medical Panel to consider the standardisation of bio-dynamic impact testing with special reference to helmets, seats and harnesses. Helmets were considered separately (Agard Report No.629). This report is based on replies to questionnaires sent to research laboratories, and catalogues 52 impact test devices.</p> <p>P.T.O.</p>	<p>AGARD-R-658</p> <p>Impact tests Biodynamics Helmets Seats Straps Loads (forces) Acceleration (physics) Test facilities Standard operating procedures</p>

<p>They are listed according to the operating organisations, and classified by principle of operation (accelerators, decelerators, horizontal, vertical etc). Details of construction, performance and use of each facility are given. Also described are some current standards for crash impact testing and the principles of operation of the more common types of test devices.</p> <p>This Report was prepared at the request of the Aerospace Medical Panel of AGARD.</p> <p>ISBN 92-835-1256-1</p>	<p>They are listed according to the operating organisations, and classified by principle of operation (accelerators, decelerators, horizontal, vertical etc). Details of construction, performance and use of each facility are given. Also described are some current standards for crash impact testing and the principles of operation of the more common types of test devices.</p> <p>This Report was prepared at the request of the Aerospace Medical Panel of AGARD.</p> <p>ISBN 92-835-1256-1</p>
<p>They are listed according to the operating organisations, and classified by principle of operation (accelerators, decelerators, horizontal, vertical etc). Details of construction, performance and use of each facility are given. Also described are some current standards for crash impact testing and the principles of operation of the more common types of test devices.</p> <p>This Report was prepared at the request of the Aerospace Medical Panel of AGARD.</p> <p>ISBN 92-835-1256-1</p>	<p>They are listed according to the operating organisations, and classified by principle of operation (accelerators, decelerators, horizontal, vertical etc). Details of construction, performance and use of each facility are given. Also described are some current standards for crash impact testing and the principles of operation of the more common types of test devices.</p> <p>This Report was prepared at the request of the Aerospace Medical Panel of AGARD.</p> <p>ISBN 92-835-1256-1</p>