

AD-AU47 208

MAGNAVOX-GENERAL ATRONICS PHILADELPHIA PA F/G 17/2.1
ADAPTIVE SAME FREQUENCY REPEATER (SFR) BREADBOARD IMPROVEMENTS.(U)
OCT 77 B S ABRAMS, M CARACAPPA, A E ZEGER F30602-74-C-0242
GAC-2896-2876-36 RADC-TR-77-347 NL

UNCLASSIFIED

| 07 |

ADAD47 208

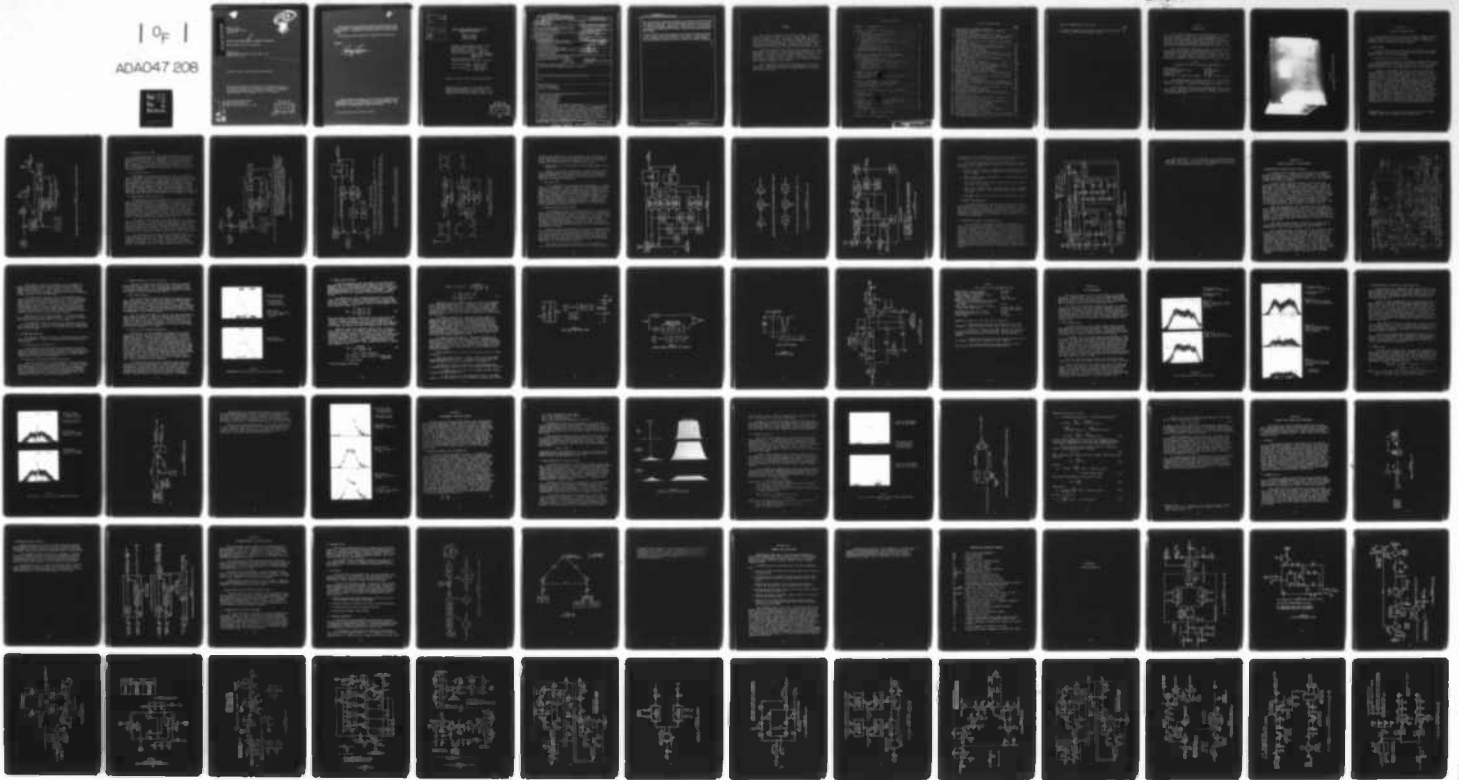

END

DATE

FILMED

1 - 78

DDC

1 OF 1

ADA047 208

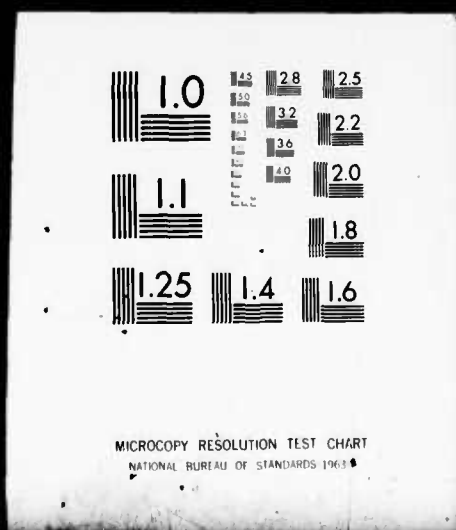

AD A 0 4 7 2 0 8

RADC-TR-77-347
Final Technical Report
October 1977



ADAPTIVE SAME FREQUENCY ^{Repeater} (SFR) BREADBOARD IMPROVEMENTS
Magnavox/General Atronics Corporation

Sponsored by
Defense Advanced Research Projects Agency (DOD)
ARPA Order No. 2750

Approved for public release; distribution unlimited.

The views and conclusions contained in this document are those of the authors and should not be interpreted as necessarily representing the official policies, either expressed or implied, of the Defense Advanced Research Projects Agency or the U. S. Government.

AD No. _____
DDC FILE COPY

ROME AIR DEVELOPMENT CENTER
Air Force Systems Command
Griffiss Air Force Base, New York 13441

DDC
RECEIVED
DEC 2 1977
D

This report has been reviewed by the RADC Information Office (OI) and is releasable to the National Technical Information Service (NTIS). At NTIS it will be releasable to the general public, including foreign nations.

This report has been reviewed and is approved for publication.

APPROVED:

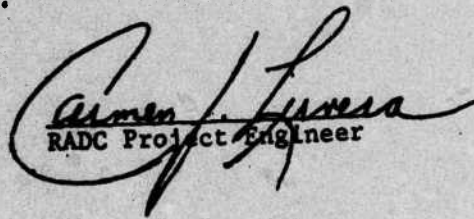
RADC Project Engineer

If your address has changed or if you wish to be removed from the RADC mailing list, or if the addressee is no longer employed by your organization, please notify RADC (DCCR) Griffiss AFB NY 13441. This will assist us in maintaining a current mailing list.

Do not return this copy. Retain or destroy.

ACCESSION for	
NTIS	White Section <input checked="" type="checkbox"/>
DCC	Buff Section <input type="checkbox"/>
UNANNOUNCED	<input type="checkbox"/>
JUSTIFICATION	
BY	
DISTRIBUTION/AVAILABILITY CODES	
DIST.	AVAIL. and/or SPECIAL
A	

ADAPTIVE SAME FREQUENCY REPEATER (SFR)
BREADBOARD IMPROVEMENTS

Burton S. Abrams
Michael Caracappa
Andrew E. Zeger

Contractor: Magnavox/General Atronics Corp
Contract Number: F30602-74-C-0242
Effective Date of Contract: 14 June 1976
Contract Expiration Date: 1 May 1977
Short Title of Work: Adaptive Same Frequency
Repeater (SFR) Breadboard
Improvements

Program Code Number: 7G10
Period of Work Covered: May 1976 - April 1977

Principal Investigator: Andrew E. Zeger
Phone: 215 248-3700
Project Engineer: Carmen J. Luvera
Phone: 315 330-3091

Approved for public release; distribution unlimited.

This research was supported by the Defense Advanced
Research Projects Agency of the Department of
Defense and was monitored by Carmen J. Luvera (DCCR),
Griffiss AFB NY 13441 under Contract F30602-74-C-0242.

D D C
RECEIVED
DEC 2 1977
D

UNCLASSIFIED

SECURITY CLASSIFICATION OF THIS PAGE (When Data Entered)

19 REPORT DOCUMENTATION PAGE		READ INSTRUCTIONS BEFORE COMPLETING FORM	
1. REPORT NUMBER 18 RADC TR-77-347 ✓	2. GOVT ACCESSION NO.	3. RECIPIENT'S CATALOG NUMBER	
4. TITLE (and Subtitle) 9 ADAPTIVE SAME FREQUENCY REPEATER (SFR) BREADBOARD IMPROVEMENTS	5. TYPE OF REPORT & PERIOD COVERED 9 Final Technical Report, 14 Jun 76 - 1 Apr 77		
7. AUTHOR(s) 10 Burton S./Abrams, Michael/Caracappa Andrew E./Zeger	6. PERFORMING ORG. REPORT NUMBER 14 GAC-2896-2876-36 ✓		
9. PERFORMING ORGANIZATION NAME AND ADDRESS Magnavox/General Atronic Corporation 1200 Mermaid Lane Philadelphia PA 19118	8. CONTRACT OR GRANT NUMBER(s) 15 F30602-74-C-0242, ✓ ✓ ARPA Order - 2750		
11. CONTROLLING OFFICE NAME AND ADDRESS Defense Advanced Research Projects Agency 1400 Wilson Boulevard Arlington VA 22209	10. PROGRAM ELEMENT, PROJECT, TASK AREA & WORK UNIT NUMBERS J. O. 27500001 1200 16 62702E		
14. MONITORING AGENCY NAME & ADDRESS (if different from Controlling Office) Rome Air Development Center (DCCR) Griffiss AFB NY 13441 128100	12. REPORT DATE 11 Oct 1977		
16. DISTRIBUTION STATEMENT (of this Report) Approved for public release; distribution unlimited.	13. NUMBER OF PAGES 73		
17. DISTRIBUTION STATEMENT (of the abstract entered in Block 20, if different from Report) Same	15. SECURITY CLASS. (of this report) UNCLASSIFIED		
18. SUPPLEMENTARY NOTES RADC Project Engineer: Carmen J. Luvera (DCCR)	15a. DECLASSIFICATION/DOWNGRADING SCHEDULE N/A		
19. KEY WORDS (Continue on reverse side if necessary and identify by block number) Interference Cancellation Adaptive Antenna Array VHF-UHF Communications Same Frequency Repeater F1 - F1 Radio Relay			
20. ABSTRACT (Continue on reverse side if necessary and identify by block number) This report documents the technical effort conducted under Amendment P00003 to Contract F30602-74-C-0242. It presents the results of modifications to the real time, nonsampling, Same-Frequency Repeater breadboard equipment originally constructed under the above contract effort. The SFR is capable of relaying various types of analog and digital signals using coherent interference cancellation techniques to prevent oscillation. The main thrust of this effort was to increase the forward gain from the 67 dB obtained in the initial effort to a performance goal of 100 - 120 dB.			

391 309

LB

UNCLASSIFIED

SECURITY CLASSIFICATION OF THIS PAGE(When Data Entered)

The actual measured forward gain achieved in this follow-on effort was 102dB. This improved forward gain was attained through modification of circuits in the breadboard equipment. The basic SFR system structure, and the concepts on which it was predicated remain intact. The results of the initial effort are summarized in RADC-TR-76-78 entitled, "Adaptive Same Frequency Repeater (SFR) Study".

The modifications that were performed and the performance results obtained in this follow-on effort are discussed in this report. Updated system and circuit diagrams are included as well as a discussion of those technical areas where additional work would further improve SFR equipment performance.

UNCLASSIFIED

SECURITY CLASSIFICATION OF THIS PAGE(When Data Entered)

SUMMARY

This report documents the technical effort on Amendment P00003 to Contract F30602-74-C-0242. It presents the results of modification to a real time, nonsampling, Same-Frequency Repeater (SFR) breadboard. The SFR is capable of relaying various types of analog and digital signals, using coherent interference cancellation techniques to prevent oscillation. The breadboard was originally constructed under the above contract.

The main thrust of this effort was to increase the forward gain from 67 dB obtained in the initial effort to 102 dB. The improvement was attained through modification of circuits in the breadboard. The basic system structure, and the concepts on which it was founded, remain intact. The results of the initial effort are summarized in RADC-TR-76-78, entitled, "Adaptive Same Frequency Repeater (SFR) Study."

The modifications that were performed are discussed in the report. Updated system and circuit diagrams are included. Areas where additional work would further improve performance are discussed as well.

TABLE OF CONTENTS

	<u>Page</u>
SECTION I - INTRODUCTION.....	1
SECTION II - REVIEW OF PREVIOUS WORK.....	3
1. SFR Concepts.....	3
a. Interference Cancellation System.....	3
b. ICS Applied to an SFR.....	5
c. Pilot-Directed ICS.....	5
d. Multichannel Notch Filter ICS.....	5
e. Combination of Pilot-Direction with the Multi- channel Notch Filter ICS.....	9
f. RF and IF ICS.....	9
g. SFR Conceptual Block Diagram.....	9
2. Hardware Implementation.....	13
3. Experimental Results of Original SFR.....	13
SECTION III - MODIFICATIONS TO SFR BREADBOARD.....	16
1. Description of Modified Block Diagram.....	16
2. System Modifications.....	18
a. IF Rejection in RF Front End.....	18
b. Isolation of Transmitted Signal from Pilot.....	18
c. Redistribution of IF ICS Loop Gain.....	19
d. AGC Time Constant.....	19
e. Drivers for RF Bipolar Attenuators.....	19
f. High Q Notch Filters.....	21
SECTION IV - SFR PERFORMANCE.....	28
1. Pilot Cancellation.....	28
2. Cancellation of Transmitted Signal and Pilot.....	31
3. Forward Gain.....	31
SECTION V - PERFORMANCE LIMITING FACTORS.....	36
1. Transmitted Signal, Pilot Interaction.....	36
2. Noise Modulation of the RF Weight.....	37
3. RF Weight Linearity.....	39
SECTION VI - RESULTS WITH OTHER PILOT WAVEFORMS.....	44
1. FM Pilot.....	44
2. Straddle Pilot.....	44
3. Separate RF and IF Pilots.....	46
SECTION VII - RECOMMENDATIONS FOR FURTHER WORK.....	48
1. Circuit Noise in the RF Weight Control Unit.....	48
2. Linearization of the RF ICS Weight.....	48
3. Straddle Pilot.....	49
4. Field Test.....	49
5. Increased Bandwidth.....	49
SECTION VIII - SUMMARY AND CONCLUSIONS.....	53
APPENDIX A - Circuit Schematics.....	56

LIST OF ILLUSTRATIONS

	<u>Page</u>
1. Same-Frequency Repeater Breadboard.....	1
2. Interference Cancellation System for Colocated Transmitter/Receiver.....	4
3. Interference Cancellation System for SFR.....	6
4. Pilot-Directed Single-Channel ICS to Overcome Problem of Correlation Between Transmitted and Received Waveforms.....	7
5. Multichannel Notch Filter ICS Concept for Broadband Cancellation Notch.....	8
6. Pilot-Directed Multichannel Notch Filter ICS.....	10
7. Distribution of Cancellation between RF and IF.....	11
8. SFR Conceptual Block Diagram.....	12
9. SFR Functional Block Diagram.....	14
10. Block Diagram of Improved SFR Breadboard.....	17
11. Performance of AGC Amplifier with Slow Time Constant..	20
12. Usual Single-Pole Notch Filter.....	23
13. Another Approach to Notch Filter Synthesis.....	24
14. Definition of Terms.....	25
15. 30 MHz Notch Filter Schematic.....	26
16. Pilot Cancellation in RF and IF ICS's.....	29, 30
17. Cancellation of Pilot Plus CW Transmitted Signal.....	32
18. Test Setup for Forward Gain Measurement.....	33
19. SFR Output for Various Input Levels.....	35
20. Modulation Effect of ICS Circuit Noise.....	38
21. SFR Pilot Output Showing Effect of Noise Modulation of RF Weight.....	40
22. Minimum Essentials for Analysis of Effect of Third- Order Weight Nonlinearity.....	41
23. Generation of Straddle Pilot.....	45
24. Implementation of Separate RF and IF ICS Pilots.....	47
25. Generation of a Straddle Pilot with PN BPSK Sidebands.	50
26. SFR Field Test.....	51
27. RF ICS Complex Weight and Canceller A	57
28. RF Bipolar Attenuator Circuit.....	58
29. RF Preamp and Downconverter B	59
30. SFR Pilot Upconverter and RF ICS Weight Control Unit C	60
31. RF and IF Correlators.....	61
32. SFR Synchronous Detector and Lowpass Filter.....	62
33. RF Bipolar Attenuator Driver.....	63
34. SFR IF Canceller and Error Signal Distribution.....	64
35. Notch Filter Processors, Box E	65
36. F , G , H SFR IF Weight Assembly.....	66
37. IF Bipolar Attenuator Circuit.....	67
38. IF ICS Weight Control Units I , J , K	68
39. IF Bipolar Attenuator Driver.....	69
40. Notch Filter Processors, Box L	70
41. SFR Signal Upconverter, Local Oscillator Distribution and Reference Downconverter.....	71

LIST OF ILLUSTRATIONS (Continued)

	<u>Page</u>
42. SFR IF Bandpass Filter and Pilot Distribution System.	72
43. SFR 455 kHz Waveform Generator N	73

SECTION I

INTRODUCTION

This report documents the technical effort on Amendment P00003 to Contract F30602-74-C-0242. It presents the results of modification to a real time, nonsampling Same-Frequency Repeater (SFR) breadboard. The SFR is capable of relaying various types of analog and digital signals, using coherent interference cancellation techniques to prevent oscillation. The breadboard was originally constructed under the above contract.

The main thrust of this effort was to improve the 67 dB forward gain obtained in the initial effort to 102 dB. The improvement was attained through modifications of circuits in the breadboard. The basic system structure, and the concepts on which it was founded, remain intact. A summary of the present performance features of the SFR breadboard is given in Table 1.

Table 1
Performance Features of Modified SFR Breadboard

Forward Gain	102 dB
Retransmitted Signal Power	+28 dBm, linear
Center Frequency	291.8 MHz
Bandwidth	100 kHz
Output Level of Added Pilot Signal	+16 dBm, spread over 100kHz

The SFR breadboard has been packaged in a rack-mounting enclosure having a front panel height of 13-3/4 inches and a depth of 19 inches. A front view photograph is given in Figure 1.

The modifications that were performed are discussed in the report. Updated system and circuit diagrams are included. Areas where additional work would further improve performance are discussed as well.

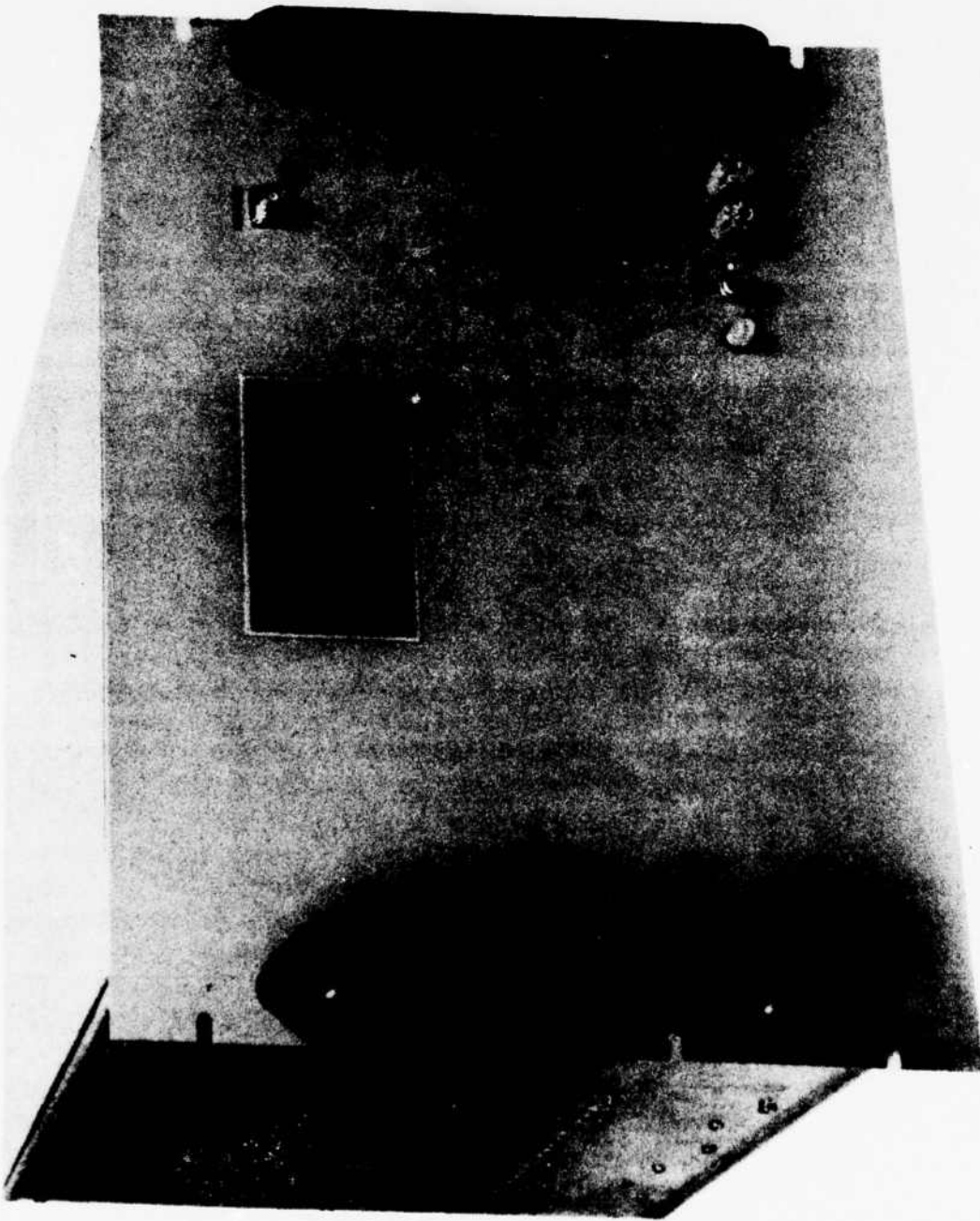

FIGURE 1
SAME-FREQUENCY REPEATER BREADBOARD

SECTION II

REVIEW OF PREVIOUS WORK

In this section, the initial work done by General Atronics in the development of the Same Frequency Repeater (SFR) is reviewed. A full exposition of this earlier work is contained in the final report submitted on that program.*

1. SFR CONCEPTS

In this section the system concepts developed for the SFR are described. Each of these concepts were verified experimentally as part of the initial program.

a. Interference Cancellation System

The motivating concept for the SFR development was the use of an Interference Cancellation System (ICS) to protect a receiver from interference by a colocated transmitter. A block diagram illustrating the ICS in this application is given in Figure 2.

Because of imperfect isolation in the antenna network, nonzero VSWR of the antenna, and reflections from nearby objects, a small portion of the transmitted signal is coupled into the receiver output of the antenna network. The transmitted signal at this point can be further reduced by an ICS. The ICS extracts a portion of the transmitted signal through a directional coupler to use as a reference waveform whose amplitude and phase is adjusted in a complex weight. When the weighted reference is combined with the signal at the output of the antenna network, proper setting of the complex weight allows the transmitted signal to be cancelled while the received signal level is maintained. The complex weight setting is adaptively controlled by a feedback system which correlates the error signal with the reference and seeks to minimize the correlation by minimizing the transmitted component of the error signal. Since the received signal and transmitted signal are generally separated in frequency, correlation of the received signal with the reference is rejected by lowpass filtering in the weight control unit.

*Abrams, B.S., *et al*, "Adaptive Same Frequency Repeater (SFR) Study," Final Report RADC-TR-76-78, March 1976.

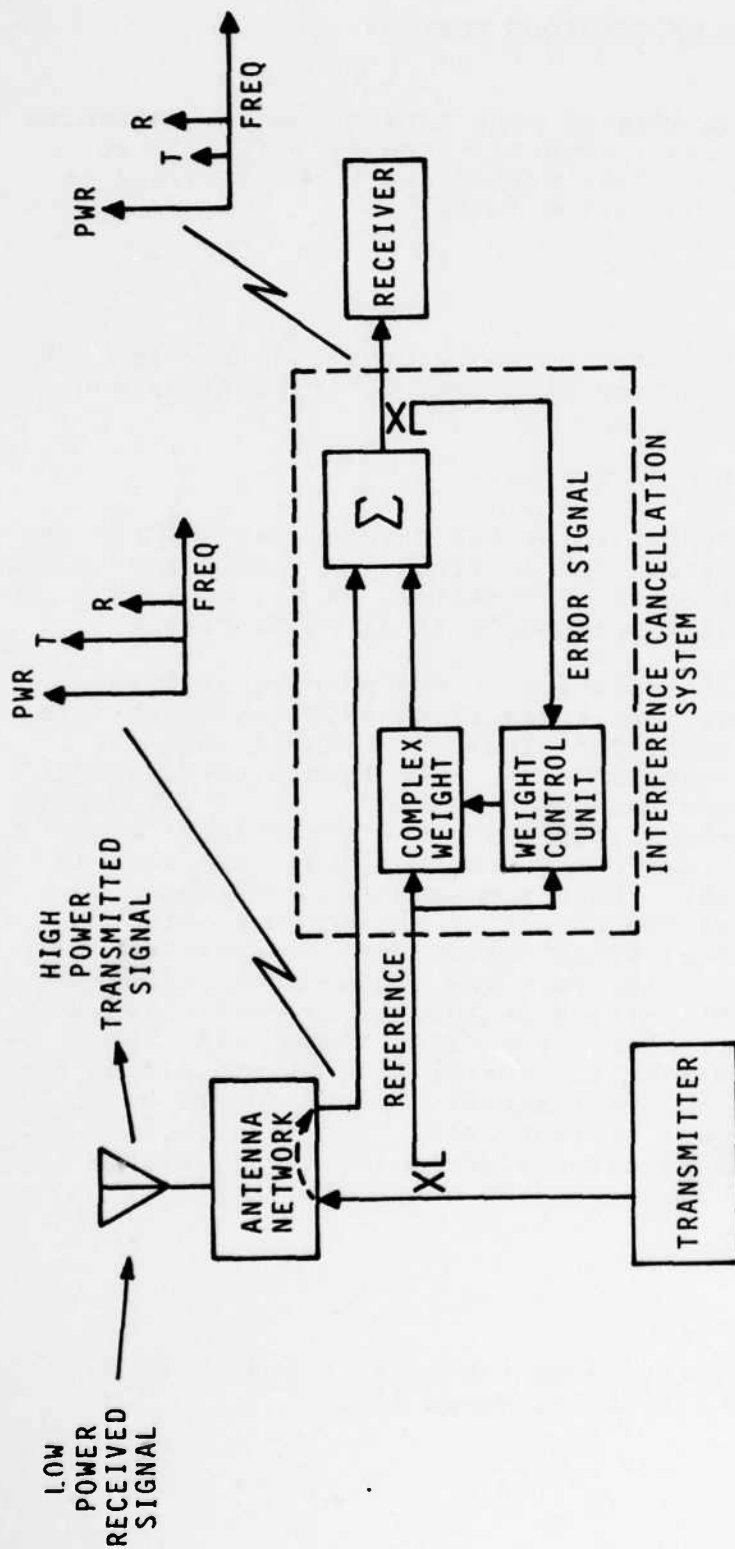

FIGURE 2
INTERFERENCE CANCELLATION SYSTEM FOR COLOCATED TRANSMITTER/RECEIVER

b. ICS Applied to an SFR

Once the principle of ICS isolation between a colocated receiver and transmitter is established, it can be extended to the SFR application without difficulty. This is illustrated in Figure 3. The receiver and transmitter are now tuned to the same frequency and are processing the same waveform to make an SFR. Means must be provided now for the correlation control of the ICS to distinguish between the transmitted waveform and the received waveform.

c. Pilot-Directed ICS

The means of controlling the ICS by what is transmitted and not by what is received is provided by pilot direction of the ICS, as shown in Figure 4. A pilot signal is added to the transmitted signal in the same frequency band, but with a waveform structured to keep it uncorrelated with the transmitted signal. Only the pilot is applied to the ICS correlator inputs, so that the complex weight adapts to cancel the pilot coupled into the receiver. However, since the pilot and the transmitted signal both have the same coupling paths into the ICS combiner, cancelling the pilot also results in cancellation of the transmitted signal.

d. Multichannel Notch Filter ICS

The isolation provided to the SFR must exceed the forward gain if desensitization or oscillation is to be avoided. Thus, high forward gain requires a large amount of cancellation over the entire band which the relay operates. The ICS described thus far is limited in broadband cancellation by the fact that the coupled waveform to be cancelled arrives through several paths whose delays may not be known or fixed. Thus, the phase shift provided by the complex weight is correct for perfect cancellation at only one frequency, and the phase error gets progressively worse at frequencies farther removed from that one.

This effect, and the means for overcoming it, are illustrated in Figure 5. If we assume that the signal to be cancelled has a flat spectrum over some range of frequencies, and that the two paths into the ICS combiner have a differential delay, the output spectrum has an M shape, as shown at the top of the figure. Cancellation is best at the center of the spectrum and gets progressively worse toward its edges, generating a cancellation notch.

The cancellation notch may be broadened, and hence the total rejection improved, by adding other weighted channels with frequency shaping to the ICS. The frequency shaping used is one which looks most like the output spectrum of the single channel ICS, namely, a notch filter. The notch filter channel cancels the second order terms that dominate the output residue

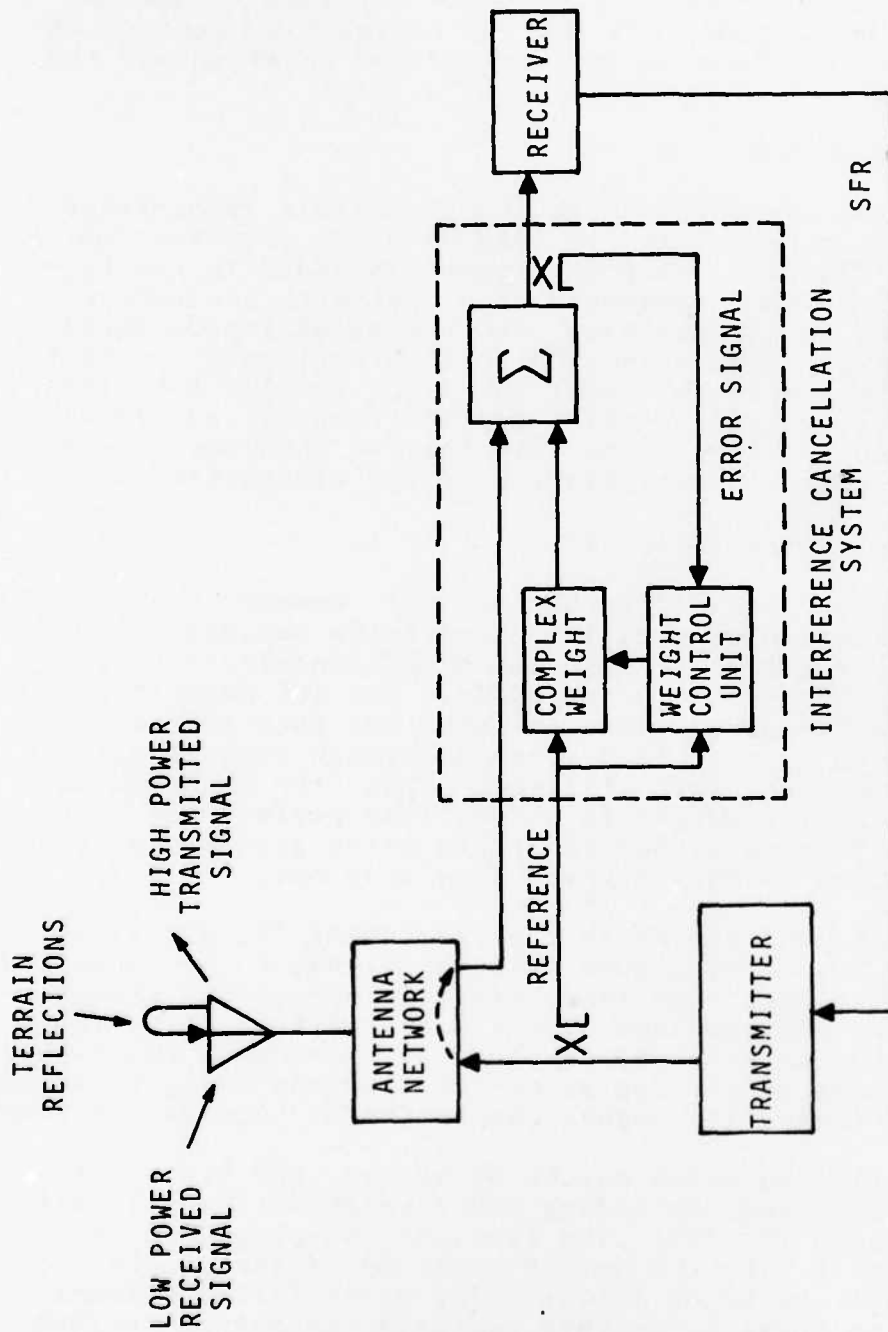

PRINCIPLE OF OPERATION: WE WANT THE ICS COMPLEX WEIGHT TO ADAPT TO CANCEL TRANSMITTER WAVEFORM ONLY, AND NOT THE RECEIVED WAVEFORM. ADAPTATION IS CONTROLLED BY CORRELATING THE CANCELLATION "ERROR SIGNAL" WITH A TRANSMITTER WAVEFORM "REFERENCE." TO MAINTAIN GOOD CANCELLATION OF THE TRANSMITTER WAVEFORM, THE TWO WAVEFORMS MUST BE UNCORRELATED.

FIGURE 3
INTERFERENCE CANCELLATION SYSTEM FOR SIR

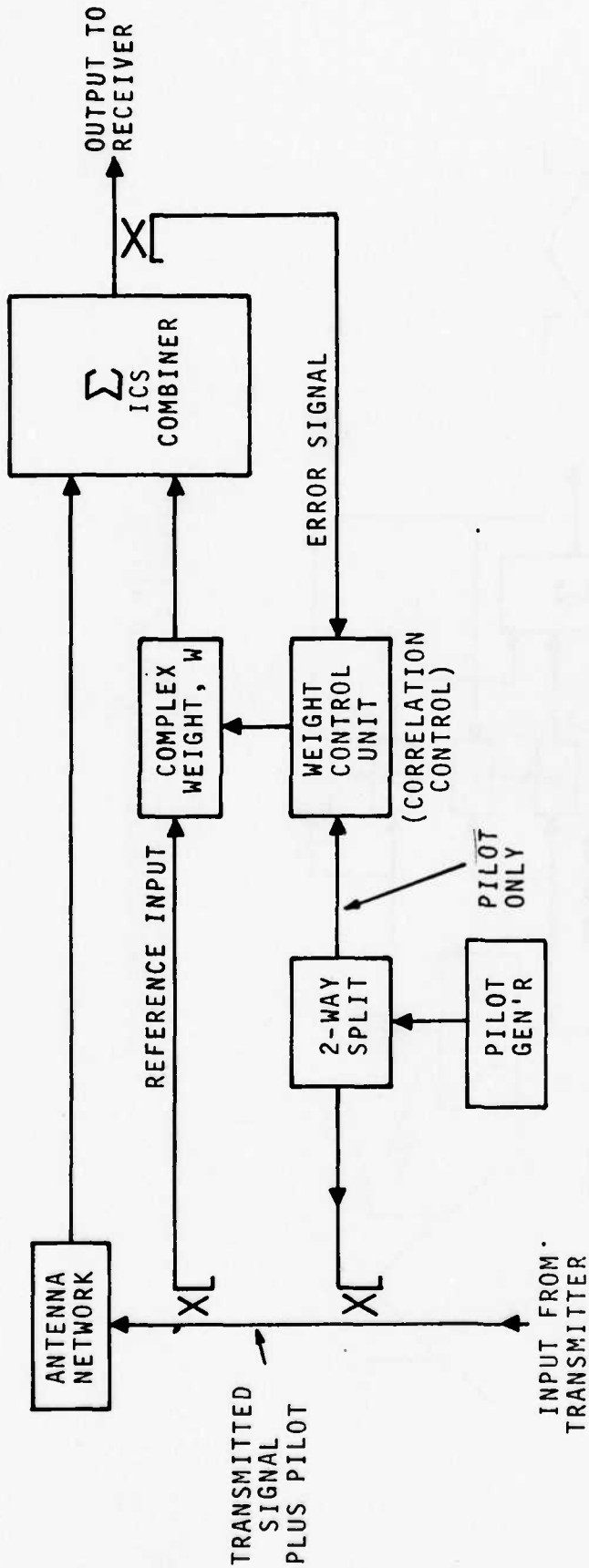

OPERATING PRINCIPLES

1. ICS CONTROLLED BY CORRELATING PILOT ONLY WITH ERROR SIGNAL, SO THAT W IS SET TO CANCEL THE PILOT, COUPLED INTO THE RECEIVER.
2. SINCE PILOT AND TRANSMITTED SIGNAL HAVE THE SAME COUPLING PATH INTO THE ICS COMBINER, THEN PILOT CANCELLATION \Rightarrow TRANSMITTED SIGNAL CANCELLATION.

FIGURE 4
PILOT-DIRECTED SINGLE-CHANNEL ICS TO OVERCOME PROBLEM OF
CORRELATION BETWEEN TRANSMITTED AND RECEIVED WAVEFORMS

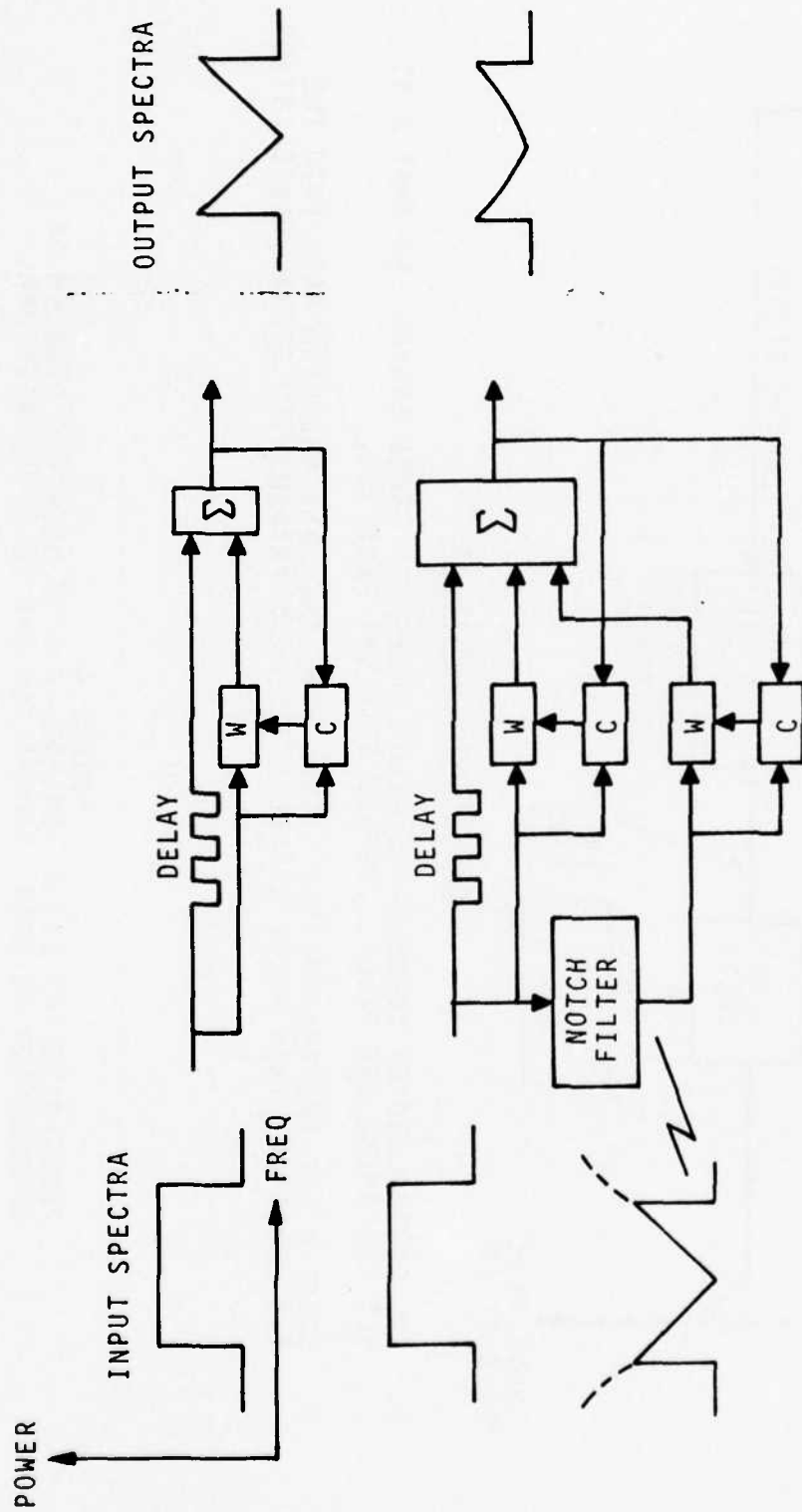

FIGURE 5
 MULTICHANNEL NOTCH FILTER ICS CONCEPT
 FOR BROADBAND CANCELLATION NOTCH

of the single-channel ICS, leaving higher order terms whose combined power level is much lower than that of the second order term. Additional notch filter channels may be used to further broaden the notch and improve broadband cancellation.

e. Combination of Pilot-Direction with the Multichannel Notch Filter ICS

Figure 6 illustrates the means by which the pilot direction and multichannel notch filter ICS concepts are combined. The pilot supplied to the weight control units must undergo the same notch filter processing as the weight inputs do. Hence, there are two notch filter chains.

f. RF and IF ICS

It is important to ensure that the achievement of a large amount of cancellation is not limited by stray leakage of signals around the canceller. Just as high gain is often achieved with gain blocks at two frequencies, with frequency conversion between them, to circumvent leakage problems, the same concept can be applied to cancellation. This is illustrated in Figure 7. The first stage of cancellation is at RF, followed by downconversion to IF, and then additional cancellation at IF. Since a single-channel ICS can provide a significant amount of cancellation before frequency dispersive effects limit it, the multichannel notch filter ICS is used at IF only.

g. SFR Conceptual Block Diagram

The concepts described in the preceding sections form the basis for the formulation of the SFR block diagram. A conceptual block diagram of the SFR is given in Figure 8. It shows a single antenna used for both transmission and reception, with a 6 dB hybrid as the antenna coupler. The received signal passes through a single-channel pilot-directed ICS at RF. The RF ICS is expected to provide 55 dB of transmit-to-receive isolation, sufficient to allow RF amplification and RF-to-IF conversion with negligible distortion.

Following RF-to-IF conversion, the signal is amplified and inserted into a three-channel pilot-directed notch filter ICS at IF. At this point the full isolation is obtained. The signal then passes through an IF filter and amplifier with AGC for output level control. The detected video output of the amplifier may be used to indicate signal presence to control the DC power supplied to the RF transmitter amplifier.

The pilot is generated and added to the signal at IF. It is also supplied to the IF ICS as well as to the RF ICS after

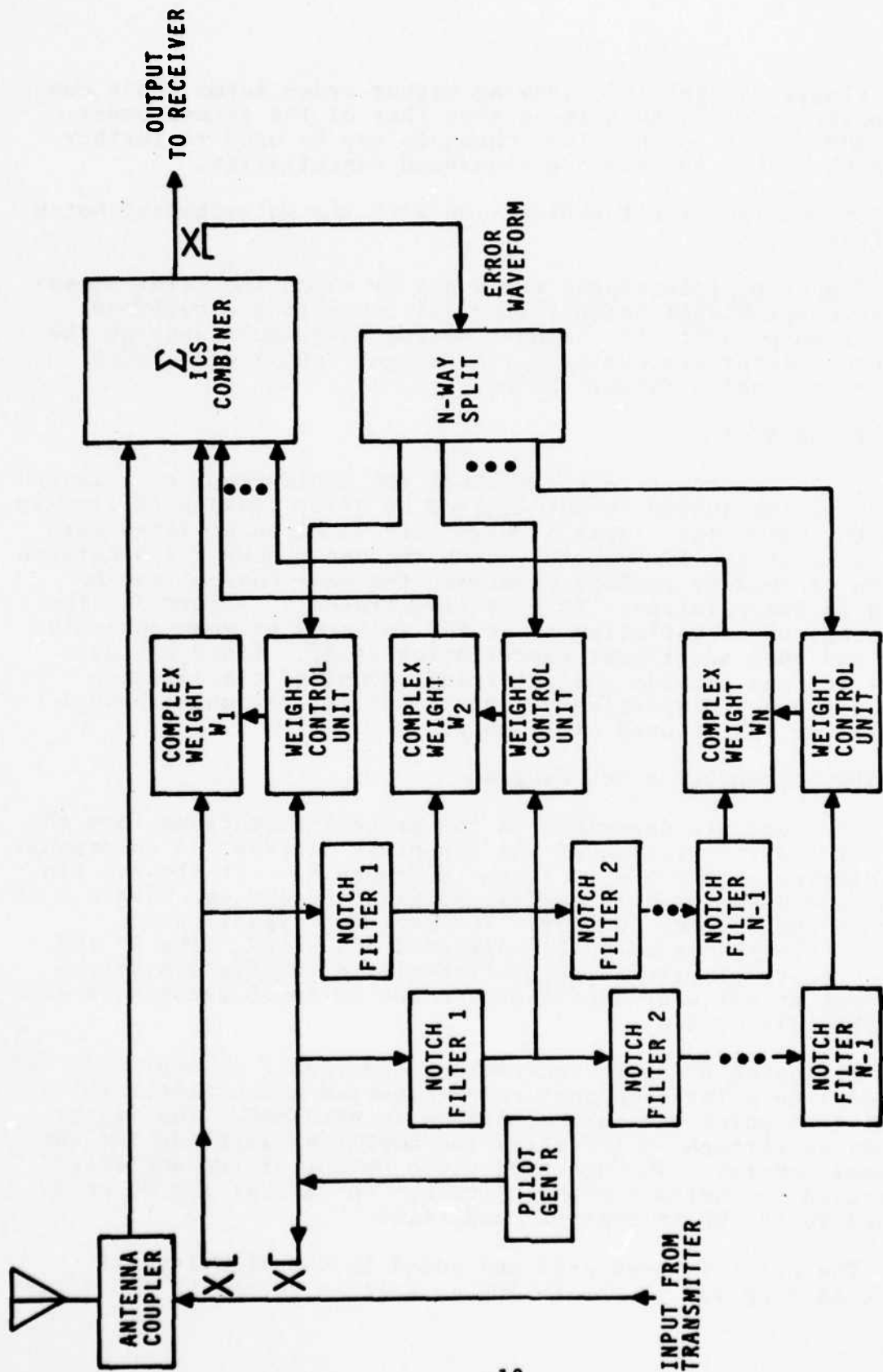
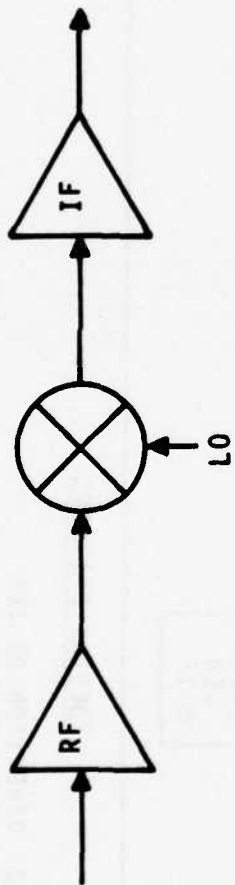
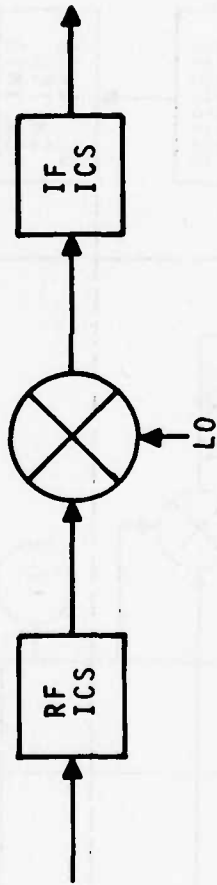

FIGURE 6
PILOT-DIRECTED MULTICHANNEL NOTCH FILTER ICS



HIGH GAIN RECEIVER WITH GAIN DISTRIBUTED BETWEEN RF AND IF



HIGH CANCELLATION DISTRIBUTED BETWEEN RF AND IF ICS'S

FIGURE 7
DISTRIBUTION OF CANCELLATION BETWEEN RF AND IF

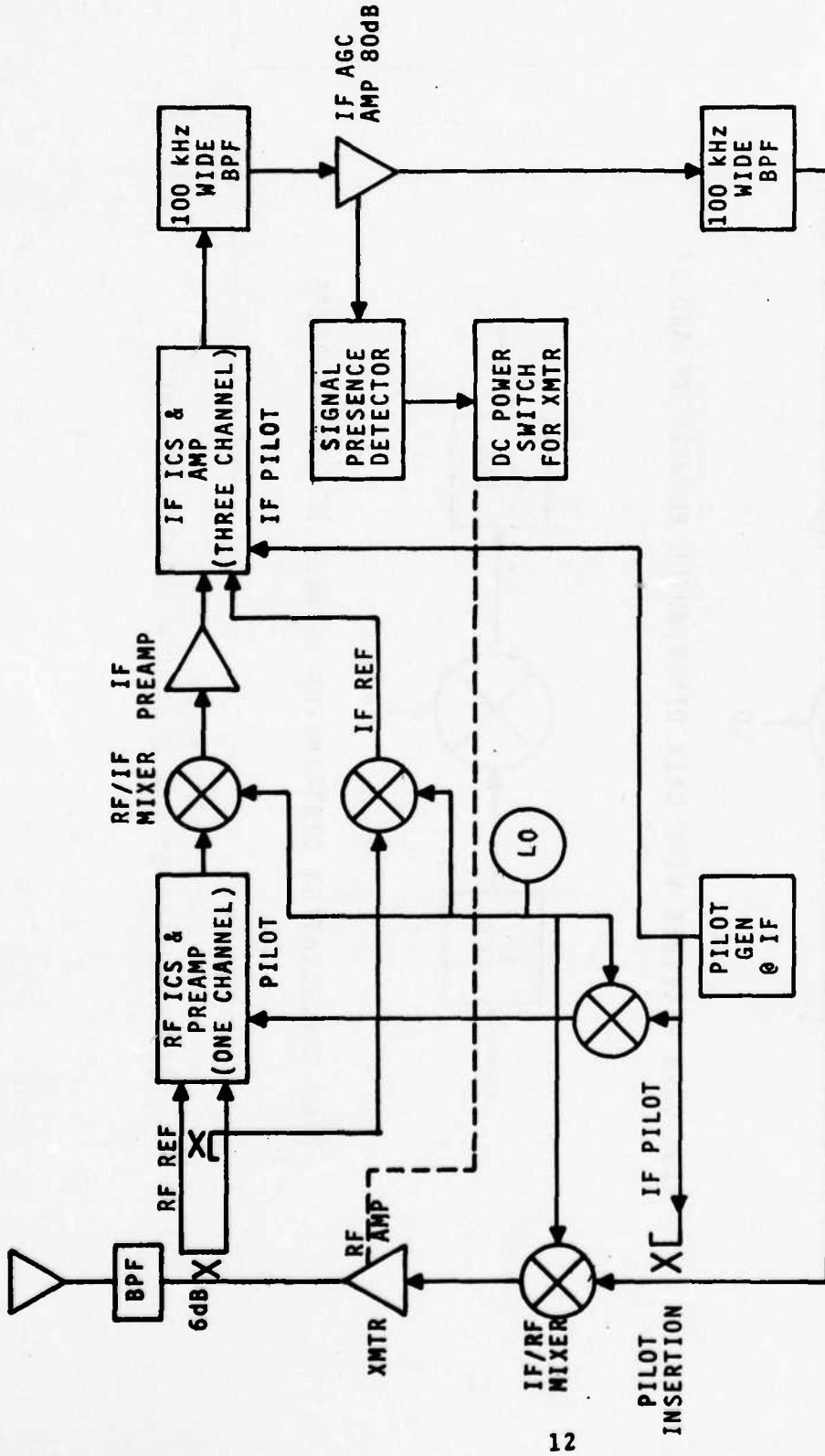

DESIGN FEATURES

1. PILOT DIRECTION OF ICS
2. RF ICS AND IF ICS
3. MULTICHANNEL ICS FOR HIGH CANCELLATION OVER BROADBAND
4. AGC CONTROL OF OUTPUT POWER LEVEL FOR LINEAR OPERATION
5. COMMON TX/RX ANTENNA

FIGURE 8
SFR CONCEPTUAL BLOCK DIAGRAM

upconversion. The combined signal plus pilot are upconverted to RF and amplified to a +28 dBm level for transmission.

The concept of using an ICS to get stable forward gain has been proven. The following design features have also been experimentally verified:

- a. Pilot control of the ICS enables cancellation of the transmitted signal without disturbance of the ICS by the received signal.
- b. High isolation can be achieved by the combination of an IF ICS with an RF ICS.
- c. The multichannel notch filter ICS provides high cancellation over a broad band.
- d. The SFR is a linear relay, with AGC control of its output power level. Thus, it can relay multiple channels within its band.
- e. The SFR operates with a single antenna for transmit and receive.

2. HARDWARE IMPLEMENTATION

A breadboard model of the SFR incorporating the features discussed above was designed and constructed according to the block diagram given in Figure 9. Each subassembly was debugged, and the subassemblies were mounted on a chassis for incorporation into a rack-mounted enclosure. Tests were run on the breadboard to determine its performance, and performance limiting factors were identified.

3. EXPERIMENTAL RESULTS OF ORIGINAL SFR

The breadboard experiments described demonstrated the operating principles on which the SFR design was predicated. They also uncovered some problems in the breadboard implementation which needed to be corrected for the SFR to operate as designed. These problem areas were: bandwidth limitations in the IF notch filter ICS which prevented its effective performance with the 100 kHz repeater bandwidth; stray coupling of the IF transmitted signal into the pilot distribution network through the pilot insertion coupler which degraded the pilot-directed cancellation in both the RF and IF ICS's; and stray coupling of the pilot into the receiver through a path not shared by the transmitted signal, namely, through the LO distribution network.

The experiments did show, however, that the SFR operating principles were valid. Forward gain was measured to be as large as 67 dB; and with modifications to the breadboard, forward gain in excess of 100 dB appeared to be achievable.

SECTION III

MODIFICATIONS TO SFR BREADBOARD

1. DESCRIPTION OF MODIFIED BLOCK DIAGRAM

A detailed block diagram of the modified SFR breadboard is given in Figure 10. It shows how the breadboard is partitioned into subassemblies, designated by letters. The functions of each subassembly are shown in the diagram. Detailed schematic diagrams are given in Appendix A.

An input signal from the antenna is coupled into the Antenna Input of Box A through a 6 dB coupler. Also present on this input are coupled components of the transmitted signal and the pilot. The fourth port of the same 6 dB coupler serves to provide a portion of the transmitted signal and the pilot to the Reference Input of Box A. The Reference Input, attenuated by 26 dB, is outputted from Box A for down-conversion to IF for further use in the IF ICS. A larger portion of the Box A Reference Input (attenuated by 6 dB) is adjusted by the RF weight to effect cancellation of the coupled RF transmitted signal and pilot in a 3 dB hybrid combiner. The RF weight is designed to impart very low intermodulation distortion upon the reference signal.

After RF cancellation, the received signal and cancellation residue are provided to Box B where they are amplified and down-converted to 30 MHz and outputted to Box D. A sample of the RF ICS output is extracted for use as the RF ICS feedback error signal. It is chopped at a 455 kHz rate. Chopping sidebands that appear in the main line of the error coupler are at multiples of 455 kHz from the RF, and will subsequently be rejected by 100 kHz wide filters at IF.

The chopped preamp output is fed to Box C, where it is correlated with I and Q versions of the up-converted pilot to generate the I and Q control signals for the RF weight.

The output from Box A carrying the 26 dB attenuated version of the Box A Reference Input is connected to Box M where it is further attenuated by 20 dB and then down-converted to IF. The attenuation is necessary to avoid generating intermodulation distortion in the down-converting mixer. The resulting signal, containing the transmitted signal and pilot at IF, forms the reference input for the IF ICS weights. It is provided to the three IF ICS weights, located in Boxes F, G and H, from output taps on a cascade of 30 MHz notch filters located in Box E. The taps are extracted by 3 dB hybrid splitters. Each stage of notch filtering is separated by an amplifier to provide isolation between the notches and to restore some gain to the notched signals.

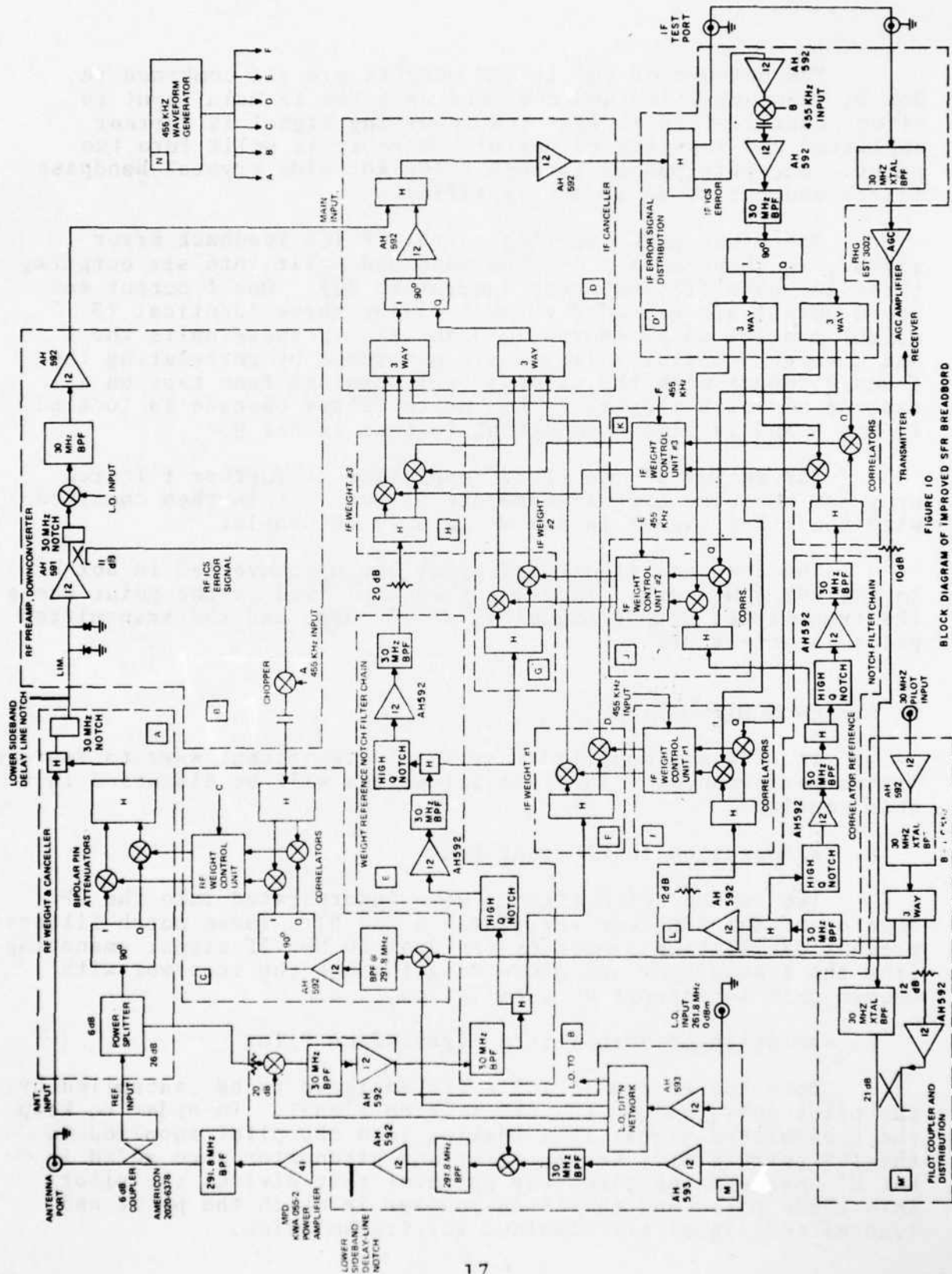

FIGURE 10
BLOCK DIAGRAM OF IMPROVED SFR BREADBOARD

The outputs of the IF ICS weights are all combined in Box D, then amplified and combined with the IF Main Input to effect cancellation at IF. The resulting signal is further amplified and supplied to Box D', where it is split into two paths. One path passes through a 100 kHz wide crystal bandpass filter and out to an IF AGC amplifier.

The other path, serving as the IF ICS feedback error signal, is chopped at a 455 kHz rate and split into six outputs, three in-phase (I) and three quadrature (Q). One I output and one Q output are provided to each of the three identical IF weight control units (Boxes I, J and K). In these units the I and Q weight control voltages are generated by correlating the I and Q inputs with the pilot signal obtained from taps on a cascade of notch filters. This notch filter cascade is located in Box L and is almost identical to that in Box E.

The output of the IF AGC amplifier is further filtered by a 100 kHz wide crystal bandpass filter. It is then combined with the pilot signal in Box M' in a 21 dB coupler.

The combined signal and pilot are up-converted in Box M to the 291.8 MHz RF. They are then amplified to the point where the transmitted output signal is at +30 dBm, and the transmitted pilot is at +18 dBm.

2. SYSTEM MODIFICATIONS

The SFR was modified in several significant ways to improve system performance. These modifications will be discussed in this section.

a. IF Rejection in RF Front End

Two 30 MHz notch filters were incorporated into the RF section of the SFR receiver (Boxes A and B). These notch filters prevent oscillation caused by residual 30 MHz IF signal emanating from the transmitter and proceeding through the receiver with enough gain to support an oscillation.

b. Isolation of Transmitted Signal from Pilot

Both the RF and IF ICS's are designed to be controlled by the pilot only, not by the transmitted signal. In order to keep the transmitted signal from leaking into the pilot supplied to the ICS correlators, an amplifier and attenuator were added in Box M' between the three-way splitter that divides the pilot into three paths and the 21 dB coupler in which the pilot and transmitted signal are combined for transmission.

c. Redistribution of IF ICS Loop Gain

In order to improve the cancellation limitation imposed by DC offsets in IF ICS weight control units, loop gain in the IF ICS was redistributed. A 12 dB amplifier was added in the IF ICS error signal path, and a corresponding amount of DC gain was removed from the weight control units.

d. AGC Time Constant

The IF AGC amplifier (RHG #EST 3002) was supplied with a fast time constant. Thus, when an AM signal with modulating frequencies between 300 Hz and 3 kHz was supplied to it, the AGC would follow the AM and strip it from the carrier. Spectrally, this could be seen as greatly suppressing the modulation sidebands of an AM input signal. The AGC time constant was slowed so that no reduction in the sidebands was apparent when an AM signal with 75% modulation by 400 Hz was applied.

The slow AGC performance is shown in the spectrum analyzer photographs of Figure 11. The upper photograph shows the AM input, with the 400 Hz sidebands \approx 10 dB below the carrier. The lower photograph shows the AGC output, with the 10 dB ratio of carrier to 400 Hz sidebands maintained. The AGC does introduce a small amount of distortion evidenced by the lower level 800 Hz and 1200 Hz sidebands at its output.

e. Drivers for RF Bipolar Attenuators

The drivers for the RF bipolar attenuators are voltage-controlled current sources incorporating nonlinear shaping to compensate for the nonlinear control characteristic of the bipolar attenuators. The shaping is accomplished by a piecewise linear approximation to the desired nonlinear characteristic. The break points in the piecewise linear approximation were originally determined by resistive voltage dividers operating from the -15V system power supply. It was found that the small ripple on the power supply voltage caused slight variations in the control currents for the bipolar attenuators, which in turn caused a low level modulation of the RF signal and pilot passing through the attenuators. This modulation introduces some low level sidebands on the output of the RF ICS, which is fed to the IF ICS. These sidebands are not present on the reference input to the IF ICS, and hence are not cancelled.

The break point network was redesigned using high value resistors to set the break points, so that a bypass capacitor provides heavy filtering before they are provided to the current drivers. Buffering of these high resistance voltages is obtained by operational amplifiers and emitter followers to provide the voltages with the necessary current drive capability. The new circuit is shown in Figure 33 of Appendix A.

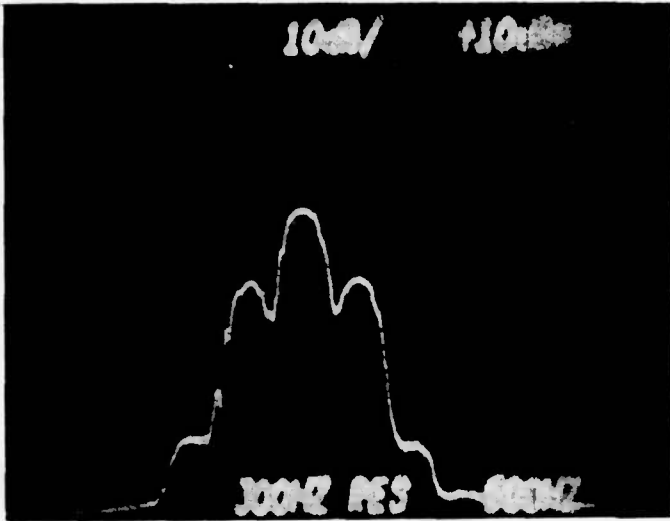

Horizontal Scale:
500 Hz/division

Vertical Scale:
10 dB/division
+10 dBm top line

Upper Photo:
Amplifier Input with
75% AM by 400 Hz
sinusoid

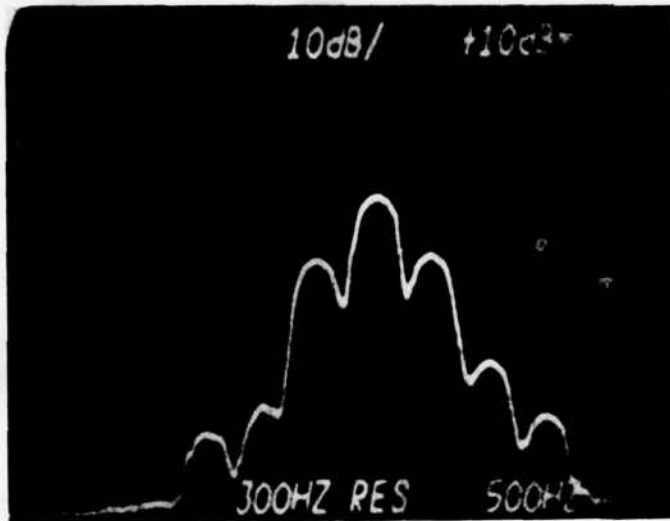

Lower Photo:
Amplifier Output

FIGURE 11
PERFORMANCE OF AGC AMPLIFIER WITH SLOW TIME CONSTANT

f. High Q Notch Filters

It was determined in the first phase of the SFR development that for the three-channel notch filter IF ICS to work properly with a pilot having 100 kHz bandwidth, the notch filter bandwidth should be about 300 kHz at the 3 dB points. Inductors having high enough Q's are not available at 30 MHz to achieve this bandwidth with any reasonable notch depth (in excess of 20 dB).

An examination of the transfer function of the single-stage notch filter in Figure 12 illustrates why a narrow, deep notch is so difficult to build at RF with ordinary lumped inductors and capacitors. The transfer function corresponding to the notch filter in Figure 12 is

$$H(S) = \frac{S^2 + \frac{1}{Q_U} \omega_0 S + \omega_0^2}{S^2 + \frac{1}{Q_L} \omega_0 S + \omega_0^2} \quad (1)$$

The notch depth (term defined in Figure 14) at the center frequency is $|H(j\omega_0)| = Q_L/Q_U$. Thus, for a notch depth of 0.1 (-20 dB), the unloaded Q_U must be ten times larger than the loaded Q_L . For a Q_L of 100 corresponding to a 300 kHz bandwidth at 30.0 MHz, the Q_U must be 1000, an impractically high value.

Figure 13 shows the approach taken to build a narrow, deep notch at 30 MHz. The signal is divided into two channels, a straight-through channel and a channel with a single-pole bandpass frequency response. When the two signals are subtracted, the overall response is that of a single-pole notch filter but with one important feature -- the notch depth may be controlled with just a gain adjustment; resonant elements with ultra-high Q's are not needed. The transfer function of a single-pole bandpass filter is

$$F(S) = \frac{K\omega_0 S/Q_L}{S^2 + \omega_0 S/Q_L + \omega_0^2} \quad (2)$$

$$\omega_0 = 1/\sqrt{LC} = \text{center frequency}$$

$$Q_L = R/2\omega_0 L = f_0/\Delta f, \text{ where } \Delta f \text{ is the 3 dB bandwidth}$$

$$K = \text{gain factor}$$

A little algebra then shows

$$\begin{aligned}
 H(S) &= 1 - F(S) = 1 - \frac{K\omega_0 S/Q_L}{S^2 + \frac{1}{Q_L}\omega_0 S + \omega_0^2} \\
 &= \frac{S^2 + \frac{1}{Q_L}(1-K)\omega_0 S + \omega_0^2}{S^2 + \frac{1}{Q_L}\omega_0 S + \omega_0^2} \quad (3)
 \end{aligned}$$

Comparison of this expression with (1) gives the promised result for notch depth when $K=1$: $|H(j\omega_0)| = 1-K$. Notice that for K slightly greater than one, the transfer function zeroes are to the right of the $j\omega$ -axis in the S -plane, causing a phase reversal at ω_0 . (For $K=2$, $H(S)$ would be a classic all-pass transfer function with pole-zero pairs symmetrically placed about the $j\omega$ -axis.)

A circuit breadboard was constructed whose schematic diagram is shown in Figure 15. A differential amplifier, the $\mu A733$ video amplifier, performed the subtraction of the two channels. Some of the properties of the $\mu A733$ that proved desirable in this application are its 100 MHz bandwidth, 48 dB common mode rejection ratio at 30 MHz, and high input impedance. The 1 dB compression point in this particular circuit is +5 dBm. The amplifier is followed by a step-up "L" section matching network to present a high impedance to the amplifier output, thus eliciting the highest compression point.

A trimmer capacitor permits the center frequency of the notch to be adjust ± 250 kHz about 30 MHz, although the gain factor K has to be reset for each change in the center frequency. The bandwidth of the notch can be broadened by loading the band-pass filter tank with a shunt resistance. For example, 2.7 kilohms shunted across the tank increased the notch bandwidth from 350 kHz to 670 kHz.

The breadboard test results for the notch filters is given in Table 2.

The notch filter chains in Boxes E and L were redesigned using these new notch filters. Schematics for these boxes are given in Figures 35 and 40, respectively, of Appendix A.

Setting up the notch filter must be done methodically. A random search may never get there. The tuning procedure follows:

1. Temporarily disconnect the straight-through channel to the differential amplifier.
2. Tune the input 30 MHz bandwidth filter to 30.0 MHz exactly. If the trimmer is at its minimum or maximum, use a more

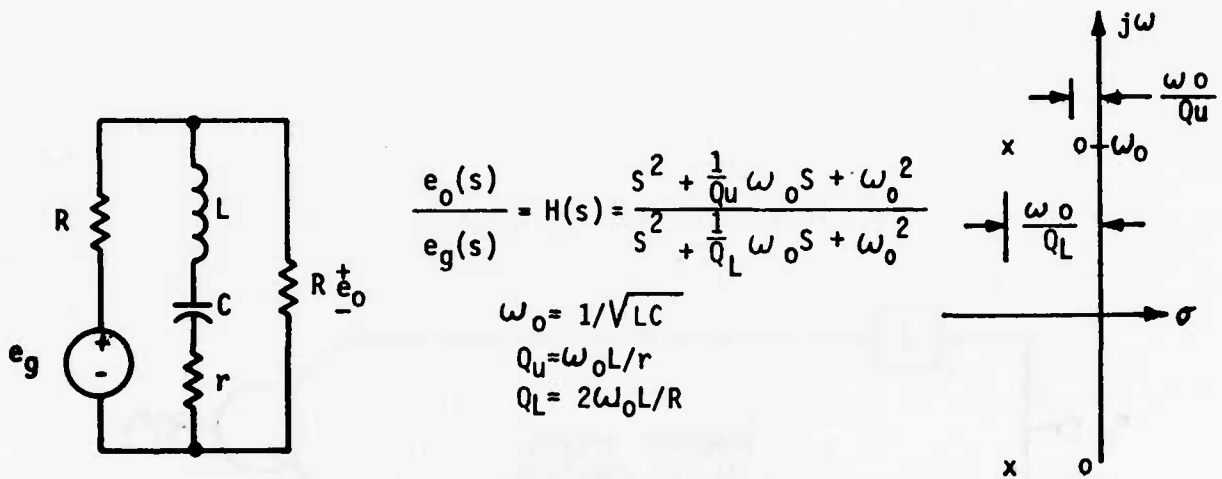
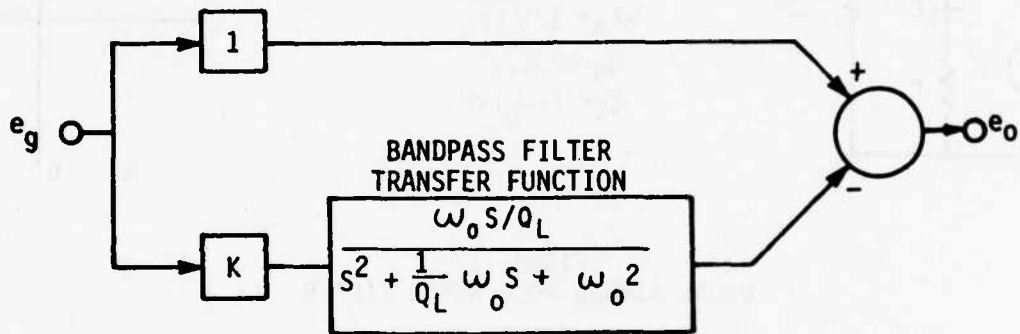

FIGURE 12
USUAL SINGLE POLE NOTCH FILTER



$$\frac{e_o(s)}{e_g(s)} = H(s) = \frac{s^2 + \frac{1}{Q_L} (1-K) \omega_0 s + \omega_0^2}{s^2 + \frac{1}{Q_L} \omega_0 s + \omega_0^2}$$

FIGURE 13
ANOTHER APPROACH TO NOTCH FILTER SYNTHESIS

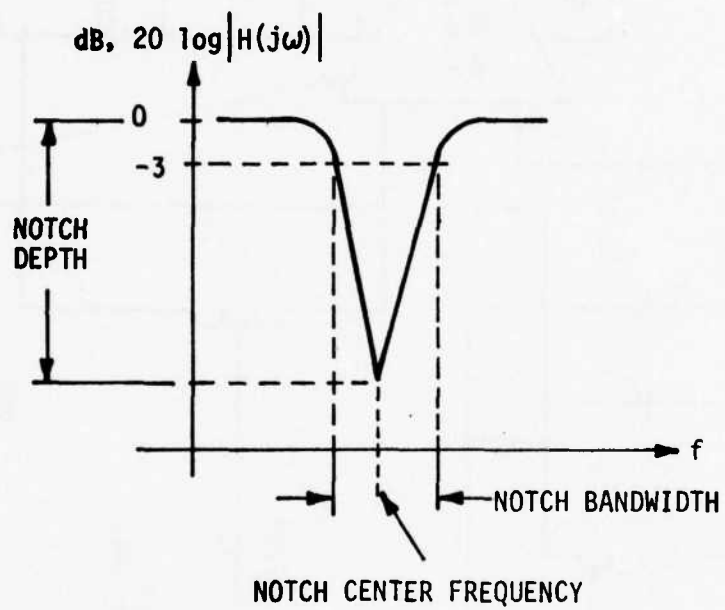

FIGURE 14
DEFINITION OF TERMS

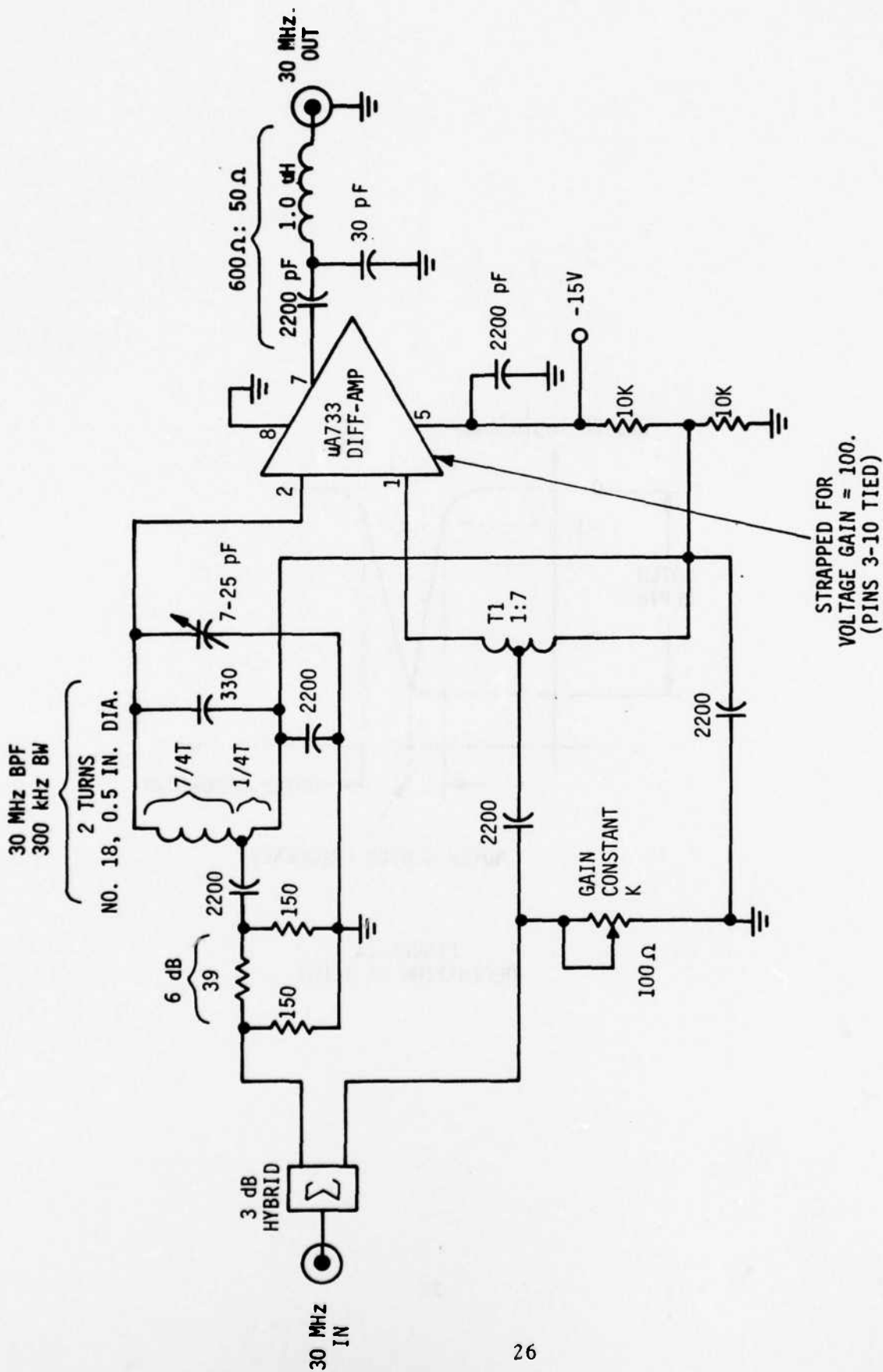

FIGURE 15
30 MHz NOTCH FILTER SCHEMATIC

Table 2

Test Results on the Breadboard Model

Notch filter center frequency	30.0 MHz
Notch filter 3 dB bandwidth	350 kHz
Center frequency adjustment range with trimmer capacitor	±250 kHz
Overall -3 dB frequencies	2 MHz & 60 MHz
Worst-case notch depth during localized heating or cooling with heat gun or freon	25 dB
Worst-case change in center frequency under same conditions	+40 kHz when cooled -25 kHz when heated
Maximum power gain (at 31 MHz)	22 dB
1 dB compression point at 31 MHz	+5 dBm
Power supply	-15 volts

appropriate value for the fixed 330 pf capacitor.

3. Move the inductor tap up or down until the 3 dB bandwidth is approximately 400 kHz ("up" increases bandwidth).

4. Feed in a signal at 30.0 MHz and mark the output on a spectrum analyzer as a reference point. Then disconnect the bandpass filter channel and reconnect the straight-through channel.

5. Adjust gain factor K until the same reference level is reached. Reconnect the bandpass filter channel.

6. Judiciously tweak the trimmer capacitor and the gain factor pot to achieve the desired notch depth.

SECTION IV

SFR PERFORMANCE

The ultimate figure of merit for the SFR is the amount of stable forward gain. This, in turn, is determined by the amount of isolation provided around the SFR loop. The bulk of the isolation is achieved by cancellation in the RF and IF ICS's, and a low VSWR antenna provides an additional 15 dB.

The ICS's in the SFR operate under direction of a biphasic pseudonoise PSK pilot signal with 100 kHz bandwidth that is added to the transmitted signal. Ideally, whatever cancellation is achieved on the pilot signal will also be achieved on the transmitted signal. Performance results will be presented in this section showing cancellation of the pilot signal alone, cancellation of the pilot plus the additional transmitted signal, and forward gain.

1. PILOT CANCELLATION

In order to measure pilot signal cancellation, the SFR was opened by disconnecting the output of the IF ICS (Box D') from the input of the IF AGC amplifier. All measurements were then taken at the IF ICS output to avoid the need for accounting for gain factors between various points in the system.

A sequence of five spectrum analyzer photographs is given in Figure 16 which shows the pilot cancellation performance. The photo at the upper left (#1) shows the pilot at the IF ICS output with its input level 60 dB lower than usual, and all ICS's disabled. (Disabling an ICS is accomplished by disconnecting the weight reference input and terminating the opened ports.) The 60 dB reduction is done to avoid saturation on the uncanceled pilot in the SFR receiver, and to allow the same scale to be used on the spectrum analyzer display as on the subsequent photos. All other photos in Figure 16 are taken with the pilot input at its full operating level (-8 dBm).

Photo #2 shows the pilot output with only the RF ICS enabled. It shows cancellation of the pilot in excess of 60 dB.

Photo #3 shows the pilot output with the RF ICS and the first IF ICS loop enabled. The pilot cancellation at the band edges is not improved much over that achieved by the RF ICS alone, but the spectrum has developed a notch in it due to dispersive effects. The second and third IF ICS loops correct for these dispersive effects, as shown in photos #4 and #5. The resulting pilot cancellation is in the order of 95 dB.

Vertical Scales:
10 dB/div, -30 dBm top

Horizontal Scales:
20 kHz/div

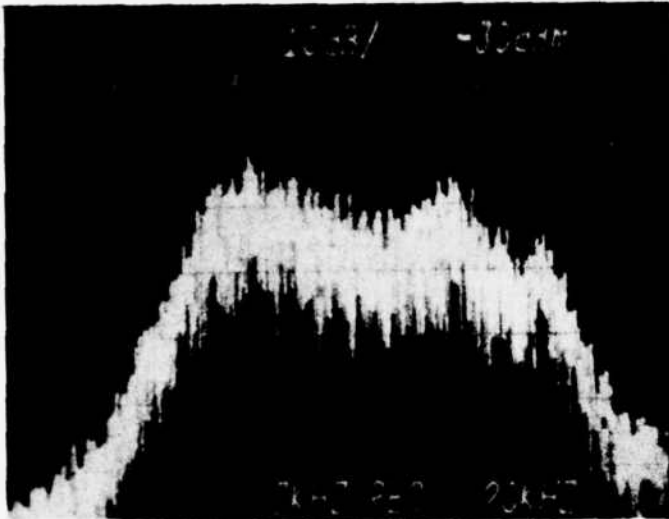

Photo #1:
Output with 60 dB attenuation at input, all ICS's disabled

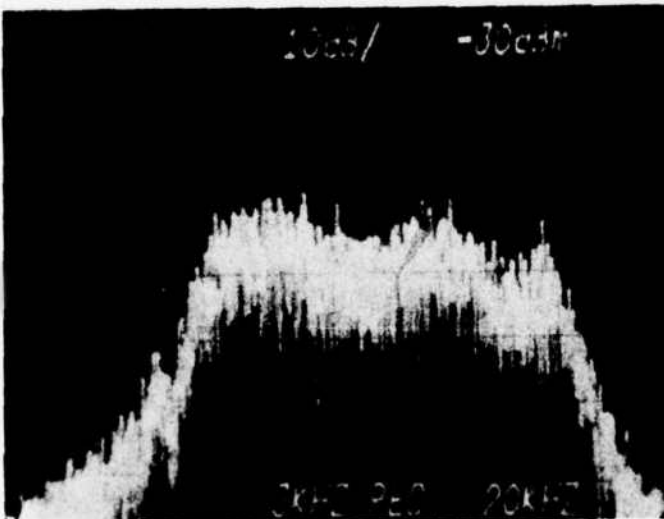
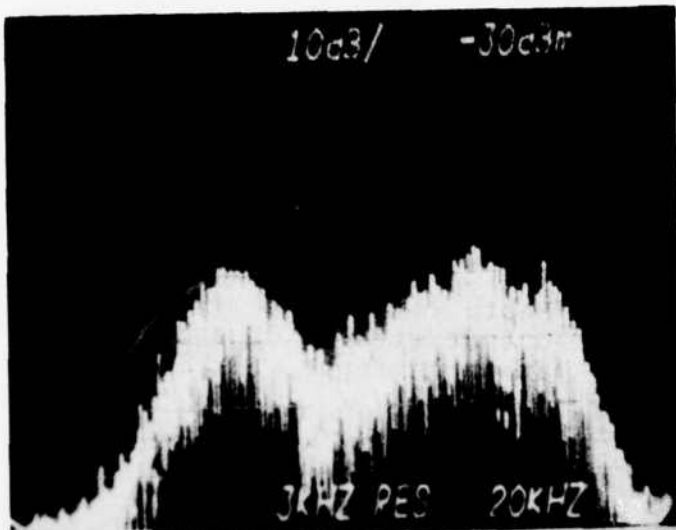

Photo #2:
Output with full pilot input, only RF ICS enabled

FIGURE 16
PILOT CANCELLATION IN RF AND IF ICS'S



Vertical Scales:
10 dB/div, -30 dBm top

Horizontal Scales:
20 kHz/div

Photo #3:
Output with RF ICS and
first IF ICS loop enabled



Photo #4:
Output with RF ICS and
first and second IF ICS
loops enabled



Photo #5:
Output with RF ICS and
all three IF ICS loops
enabled

FIGURE 16
[concluded]

2. CANCELLATION OF TRANSMITTED SIGNAL AND PILOT

Cancellation of a transmitted signal along with the pilot was tested by inserting a 30 MHz CW test signal at the IF transmitted signal input to Box M'. The input level was set to produce a desired corresponding output level at 291.8 MHz at the SFR antenna port. The output of the IF ICS was monitored on the spectrum analyzer.

Figure 17 shows photographs of the spectrum analyzer display under two conditions of transmitted signal output. The upper photo is the result with the SFR transmitted signal output level at +23 dBm. With 15 dB isolation in the antenna, 5 dB loss in Box A, 13 dB gain in Box B, 8 dB gain in Box D, and 4 dB gain in Box D', the equivalent level at the IF ICS output with no cancellation and without saturation would be +26 dBm. The cancellation residue is -64 dBm, producing a cancellation ratio of 90 dB on the transmitted signal. This cancellation ratio holds as the frequency of the transmitted signal is moved across the 100 kHz band.

The lower photo shows the result when the SFR transmitted signal output level is +28 dBm. Although the transmitted signal is 5 dB higher than above, it may be seen from the photos that its cancellation residue has increased by 10 dB, producing a cancellation ratio of 85 dB.

Cancellation of high level transmitted signals is not as good as pilot cancellation, and it degrades as the transmitted signal level is increased. This effect has been determined to be due to nonlinearity in the complex weight of the RF ICS. It is discussed more fully in Section V-3.

3. FORWARD GAIN

The SFR has one RF port (the antenna port) through which both input and output signals flow. In order to separate input and output signals, a network was made with a directional coupler and attenuator, as shown in Figure 18. Loss through the network on the output signal was measured to be 17 dB. For the input signal the loss was measured to be 27 dB. Thus, the SFR forward gain may be computed using the formula

$$\begin{aligned} G_{\text{SFR}} (\text{dB}) &= P_{\text{SA}} (\text{dBm}) - P_{\text{GEN}} (\text{dBm}) + 17 + 27 \\ &= P_{\text{SA}} (\text{dBm}) - P_{\text{GEN}} (\text{dBm}) + 44 \end{aligned} \quad (4)$$

where P_{SA} is the power level displayed on the spectrum analyzer
 P_{GEN} is the power level from the HP608 generator.

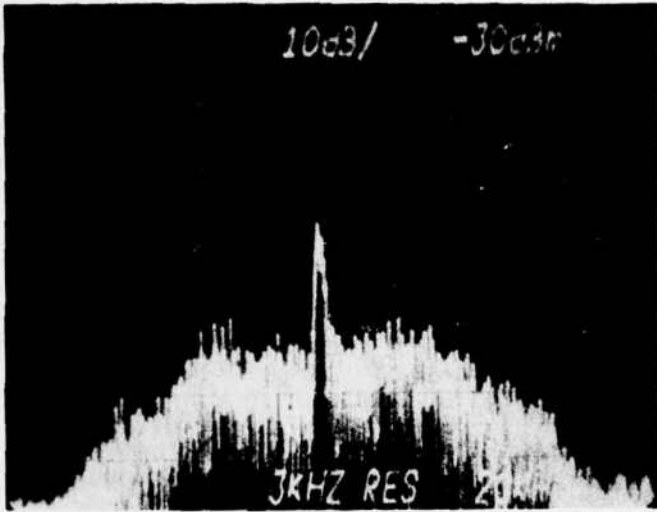

Vertical Scale:
 10 dB/division
 -30 dBm top line

Horizontal Scale:
 20 kHz/division

Upper Photo:
 Transmitted signal
 output at +23 dBm

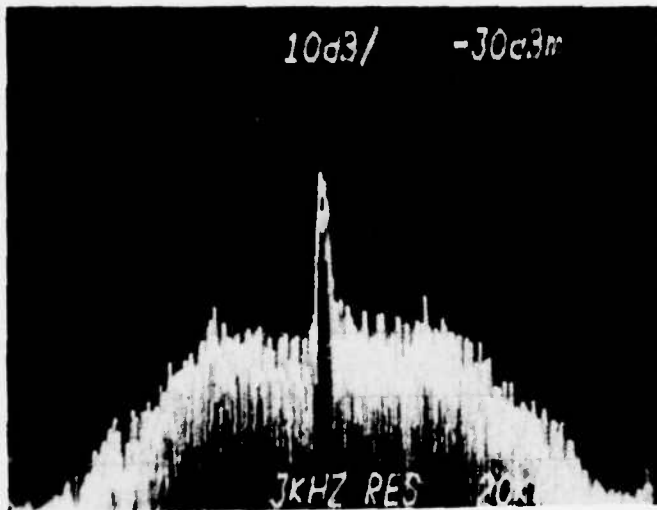

Lower Photo:
 Transmitted signal
 output at +28 dBm

FIGURE 17
 CANCELLATION OF PILOT PLUS CW TRANSMITTED SIGNAL

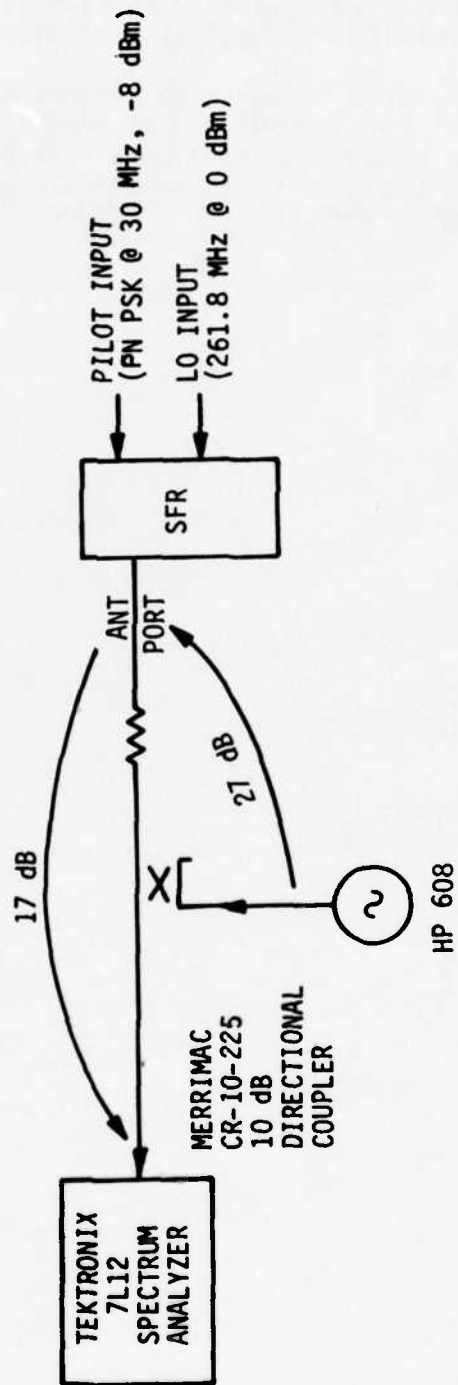
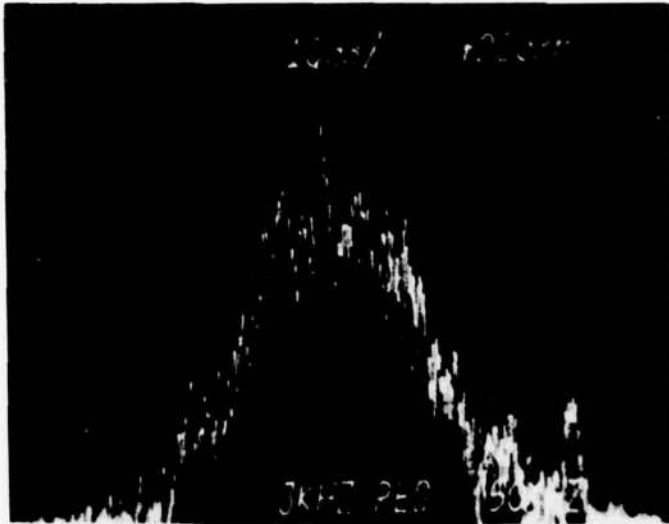

FIGURE 18
 TEST SETUP FOR FORWARD GAIN MEASUREMENT

Photographs of the SFR output are shown in Figure 19 for three difference generator levels: -36 dBm in the upper photo, -41 dBm in the middle photo, and -46 dBm in the lower photo. The output display shows a constant +12 dBm output level, corresponding to +29 dBm out of the antenna port. The forward gain for the lowest input level is computed from Equation (4) to be 102 dB.

Varying the input frequency across the 100 kHz band causes a 5-10 dB ripple in the output level when the generator level is -46 dBm. When the generator level is -36 dBm, the ripple is no larger than 1 dB. Thus, the isolation around the SFR is just sufficient to achieve the 102 dB of forward gain.



Vertical Scale:
 10 dB/division
 +20 dBm top line

Horizontal Scale:
 50 kHz/division

Upper Photo:
 Generator output at
 -36 dBm

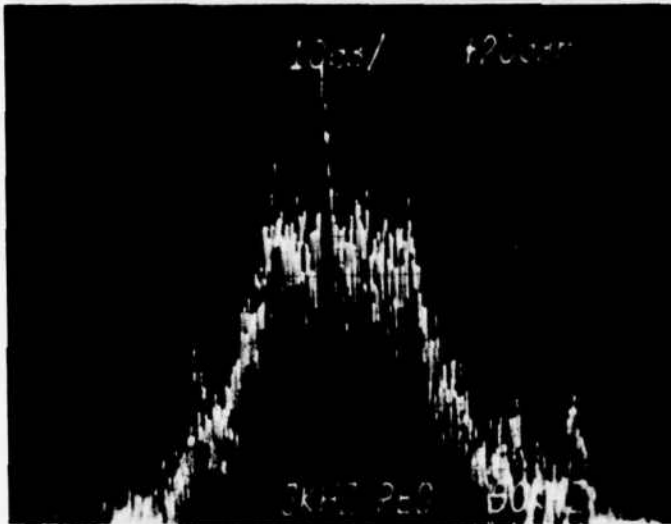

Middle Photo:
 Generator output at
 -41 dBm



Lower Photo:
 Generator output at
 -46 dBm

FIGURE 19
 SFR OUTPUT FOR VARIOUS
 INPUT LEVELS

SECTION V

PERFORMANCE LIMITING FACTORS

Several factors have been identified as ones which place limits on the achievable cancellation in the ICS's, and hence on the achievable SFR forward gain. The first factor is caused by an interaction between the pilot and the transmitted signal which would cause ICS control loop instability without very narrow loop filtering. The second factor is circuit noise in the RF ICS control loop (primarily 1/f noise and popcorn noise) which the IF ICS is too sluggish to track out due to its narrow loop filtering. The third factor is a slight amount of nonlinear distortion in the RF ICS complex weight which causes a small change in the ratio of pilot-to-transmitted signal, but a change large enough to prevent cancellation of the transmitted signal in the IF ICS by the same amount that the pilot is cancelled. These three factors are discussed more explicitly in the following subsections.

1. TRANSMITTED SIGNAL, PILOT INTERACTION

It has been found that when the ratio of transmitted signal-to-pilot is strong enough, it can cause a pilot-directed ICS to become unstable. This effect can be understood by application of the following line of reasoning. Assume initially that the pilot-directed ICS is cancelling pilot only, and then the level of the transmitted signal is gradually increased. The small transmitted signal is cancelled by the same amount as the pilot. However, since the transmitted signal appears in the pilot band, there are some correlation components between the transmitted signal residue and the pilot which pass through the loop lowpass filter and deviate the weight from its original setting. The deviated weight results in an increase in cancellation residue -- both of the pilot and of the transmitted signal. The increased pilot residue generates a control voltage which tends to restore cancellation, but the increased transmitted signal generates control voltage variations which tend to further deteriorate cancellation. The ratio of transmitted signal-to-pilot determines which effect dominates. When that ratio gets high enough, cancellation abruptly ceases. For a spread pilot in which the spacing between its spectral lines is much less than the ICS loop bandwidth, it has been found experimentally that the condition for stability is

$$\frac{P_T}{P_p} < \frac{B_p}{B_{CL}} \quad (5)$$

P_T is the transmitted signal power
 P^P is the transmitted pilot power
 B^P is the pilot bandwidth
 B_{CL}^P is the closed loop bandwidth of the ICS

Another way to view this phenomenon is that the ICS correlators provide a form of spread spectrum rejection of the transmitted signal in the control loop. For the control loop to remain stable, sufficient rejection must be provided so that the post-processing level of the transmitted signal is below that of the pilot.

The conclusion drawn from the result in (5) is that loss of cancellation due to transmitted signal-pilot interaction is prevented by making the loop bandwidth very narrow. If the transmitted signal is 12 dB stronger than the pilot, and the pilot bandwidth is 100 kHz, then the ICS closed loop bandwidth must satisfy

$$B_{CL} < 6 \text{ kHz} \quad (6)$$

Since the closed loop bandwidth is the product of the open loop bandwidth and the loop voltage gain, a loop with 60 dB of gain needs an open loop bandwidth less than 6 Hz.

2. NOISE MODULATION OF THE RF WEIGHT

Circuit noise generated in the RF ICS weight control unit will cause slight variations in the setting of the complex weight. These weight variations will, in turn, modulate the reference signal flowing through the weight. Since the modulation components are not present on the main input to the ICS, when that is combined with the weighted reference for cancellation, the modulation components will not be cancelled. This effect is illustrated in Figure 20 both for cancellation of a CW signal and cancellation of a spread signal.

Following the RF ICS by a second ICS at IF will allow cancellation of these noise modulation components only if the IF ICS loop bandwidth is wide enough to follow the modulation, thereby duplicating the modulation in its own weight. The ICS loop bandwidth is restricted, however, in order to prevent the transmitted signal-pilot interaction discussed previously.

In the time domain the noise modulation causes the cancellation residue to fluctuate. In other words, the cancellation, and hence the isolation provided by the ICS's is time-varying. Once in a while the isolation is momentarily reduced to a point where it is insufficient to keep the SFR from oscillating. This effect may be seen by examining the SFR output

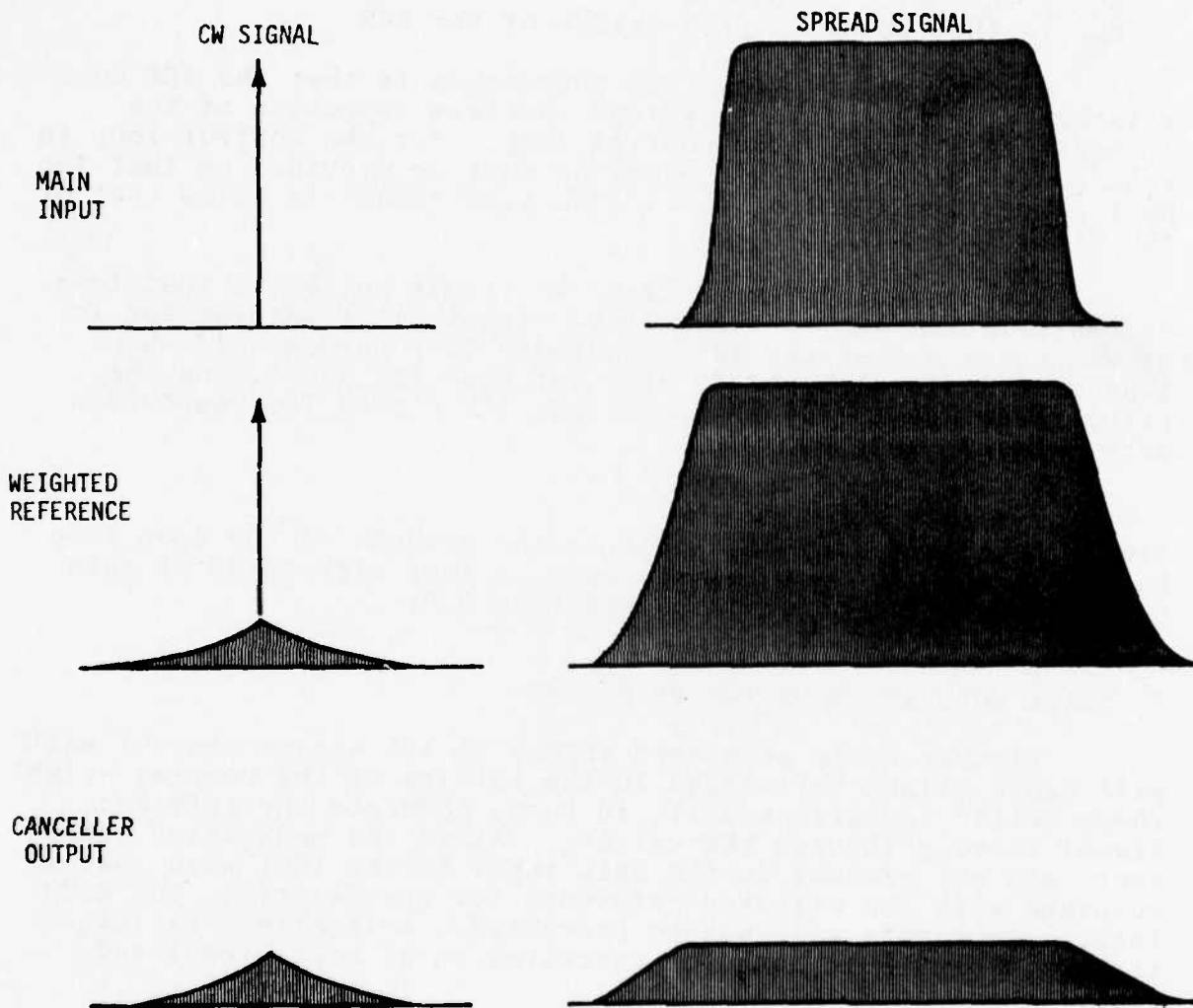

FIGURE 20
 MODULATION EFFECT OF ICS CIRCUIT NOISE

with no input signal, and full forward gain. Under this condition, the output consists only of the pilot.

Figure 21 shows spectrum analyzer photos of the pilot at the SFR's (antenna) output. The upper photo is the pilot output with the SFR loop open. The lower photo shows the SFR pilot output with the SFR loop closed. Spectral lines can be seen which are not steady, but pop up at random locations and random times.

3. RF WEIGHT LINEARITY

The third factor found to be limiting SFR performance is the linearity of the complex weight with respect to RF signals flowing through it. Deviation from perfect linearity is evidenced by the generation of third-order intermodulation products between the pilot and the transmitted signal. Thus, even if the pilot and transmitted signal could be cancelled perfectly, a residue would remain which is caused by third-order intermodulation in the weight.

A more serious problem exists, however, which arises from the same cause. That problem is that the weight nonlinearity, in addition to generating intermodulation products, also changes the ratio of the transmitted signal to the pilot. For example, if this ratio were changed by 1%, then perfect cancellation of the pilot would result in 40 dB cancellation of the transmitted signal.

It is possible to quantitatively relate the ratio change, and hence the achievable transmitted signal cancellation, to the level of the third-order intermod product generated. To do that we refer to the simple block diagram of Figure 22 in which the cancelled output voltage is given by

$$e_c = (\alpha - W)e_i - Wk_3e_i^3 \quad (7)$$

where e_i is the reference input voltage,

α is a complex scale factor that relates the main input of the ICS to its reference input,

W is the complex value assumed by the complex weight, and

k_3 is the coefficient of the cubic term that describes the weight nonlinearity

The reference is composed of two tones

$$e_i = V_T \cos \omega_T t + V_p \cos \omega_p t, \quad (8)$$

where V_T is the amplitude of the transmitted signal tone and

ω_T is its radian frequency,

V_p is the amplitude of the pilot tone and

ω_p is its radian frequency

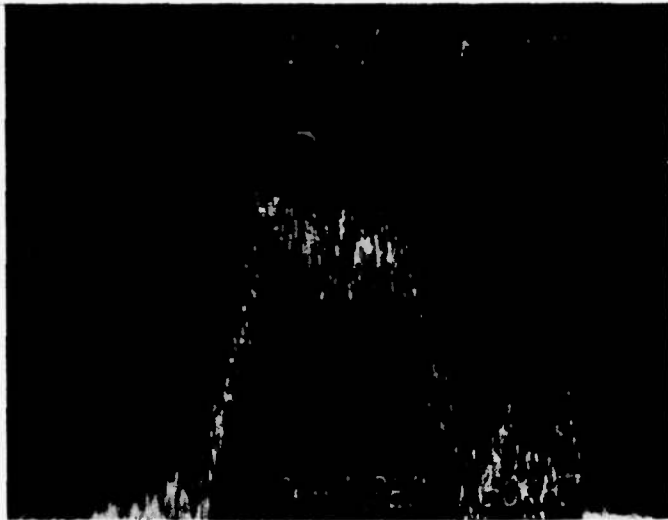

PILOT AT SFR OUTPUT
WITH SFR LOOP OPEN

Horizontal Scale:
50 kHz/division
Vertical Scale:
10 dB/division

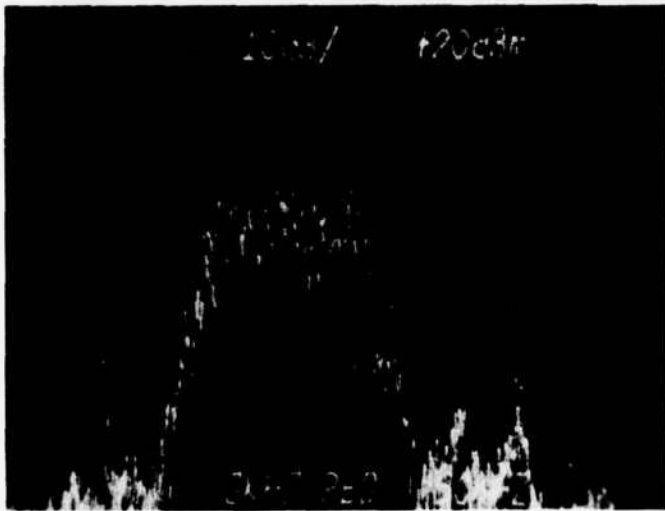

PILOT AT SFR OUTPUT
WITH SFR LOOP CLOSED

FIGURE 21
SFR PILOT OUTPUT SHOWING EFFECT OF NOISE MODULATION
OF RF WEIGHT

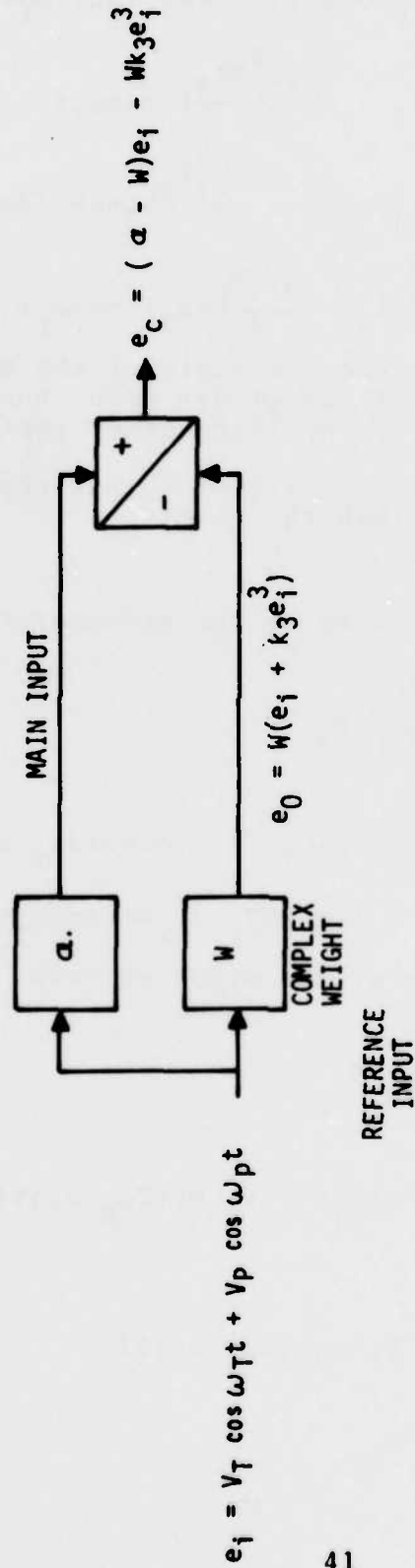

FIGURE 22
 MINIMUM ESSENTIALS FOR ANALYSIS OF EFFECT OF THIRD-ORDER WEIGHT NONLINEARITY

Inserting (8) into (7) gives

$$\begin{aligned}
 e_c &= (\alpha - W)(V_T \cos \omega_T t + V_p \cos \omega_p t) - W k_3 (V_T \cos \omega_T t + V_p \cos \omega_p t)^3 \\
 &= [(\alpha - W)V_T - \frac{3V_T^3}{4} W k_3 - \frac{3V_T V_p^2 W k_3}{2}] \cos \omega_T t \\
 &\quad - \frac{3V_T V_p^2}{4} W k_3 \cos(2\omega_T - \omega_p)t - \frac{3V_T^2 V_p}{4} W k_3 \cos(2\omega_p - \omega_T)t \\
 &\quad + [(\alpha - W)V_p - \frac{3V_p^3}{4} W k_3 - \frac{3V_T^2 V_p}{2} W k_3] \cos \omega_p t
 \end{aligned} \tag{9}$$

It may be seen from (9) that the ratio of the amplitude of $\cos \omega_T t$ to the amplitude of $\cos \omega_p t$ has been changed from V_T/V_p by an amount determined by the third-order coefficient k_3 .

We may simplify (9) by assuming that the transmitted signal is much stronger than the pilot,

$$V_T \gg V_p \tag{10}$$

and by defining the amplitude of the stronger third-order intermod to be

$$V_I = \frac{3V_T^2 V_p}{4} k_3 \tag{11}$$

We have

$$\begin{aligned}
 e_c &\approx [(\alpha - W)V_T - \frac{V_T V_I W}{V_p}] \cos \omega_T t - V_I W \cos(2\omega_p - \omega_T)t \\
 &\quad + [(\alpha - W)V_p - 2V_I W] \cos \omega_p t
 \end{aligned} \tag{12}$$

For perfect cancellation of the pilot we have

$$\alpha - W = \frac{2V_I}{V_p} W \tag{13}$$

which gives

$$e_c \approx \frac{\alpha}{1 + 2V_I/V_p} \left[\frac{V_T V_I}{V_p} \cos \omega_T t - V_I \cos(2\omega_p - \omega_T)t \right] \tag{14}$$

For $V_p \gg V_I$, we have

$$e_c \approx \alpha \left[\frac{V_T V_I}{V_p} \cos \omega_T t - V_I \cos(2\omega_p - \omega_T)t \right] \tag{15}$$

From (15) it can be seen that the amplitude of the transmitted signal cancellation residue

$$\alpha V_{CT} = \alpha V_I (V_T/V_p) \quad (16)$$

is equal to the output amplitude of the stronger third-order intermod scaled by the input ratio of transmitted signal-to-pilot. For example, if the output intermod is at a level corresponding to 100 dB of cancellation, and $V_T/V_p = 10$ dB, then the transmitted signal cancellation is limited to 90 dB.

Recent measurements of the third-order intermodulation performance of the RF ICS complex weight have shown that with the transmitted signal output level at +28 dBm and the pilot output level at +16 dBm, the third-order intermod generated by the RF ICS complex weight appears at the IF ICS output at a level of -68 dBm. According to the above theory, the transmitted signal cancellation residue at the same point should be -56 dBm (12 dB higher). This agrees with the level of the cancelled transmitted signal measured at the IF ICS output, as shown in the lower photograph of Figure 17.

It should be noted that the initial data taken* on a breadboard of the RF complex weight showed a third-order intercept approximately 8 dB higher than is currently being measured. A check of the RF ICS complex weight circuit showed it to be operating properly, except for the third-order intermod performance. Further work is needed to reestablish the intermod performance to previously measured levels.

*Abrams, B.S., *et al.*, "Adaptive Same Frequency Repeater (SFR) Study," Final Report RADC-TR-76-78 on Contract F30602-74-C-0242, March 1976, p. 62.

SECTION VI

RESULTS WITH OTHER PILOT WAVEFORMS

The bulk of the results reported herein were achieved with a pilot generated with biphase PSK modulation of a carrier by a pseudorandom noise source. The pilot was then confined to a 100 kHz band by crystal filtering. Other pilot types were tried briefly with varying results. These results are presented in this section.

1. FM PILOT

A sinusoidally frequency-modulated pilot with 100 kHz bandwidth was tested briefly. It was found that cancellation of the pilot and the transmitted signal was always worse than with the PSK pilot. If the modulation rate was high, then the pilot spectrum contained few lines, each with a significant fraction of the power. If the transmitted signal frequency were located on one of those lines, it would cause ICS loop instability far worse than when the pilot energy was more evenly distributed across the band. If the modulation rate was lowered so that the pilot spectrum contained more lines, each with a lower power level, then the ICS would tend to optimize cancellation at the instantaneous frequency, with cancellation degradation at some other frequency. The PSK pilot has the advantage of close spectral lines without an instantaneous frequency, so that cancellation is optimized over the entire 100 kHz band.

2. STRADDLE PILOT

In order to remove the interaction problem between the pilot and the transmitted signal, a pilot structure was tried in which the pilot straddles the signal band. The pilot was generated as shown in Figure 23. In order to make use of this pilot, the 100 kHz wide crystal pilot filter in Box M was bypassed.

Some difficulty was experienced in getting the second and third loops in the notch filter IF ICS to operate at all with this pilot. When they did operate, transmitted signal cancellation was about the same as with the PSK pilot. At the time, the limitations in the RF weight (noise modulation and third-order nonlinearity) were not recognized, and the straddle pilot was not pursued. It is felt that further work with the straddle pilot may be fruitful if the other performance limitations can be overcome.

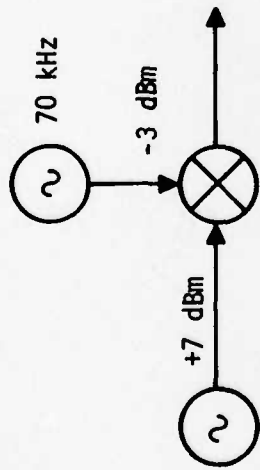
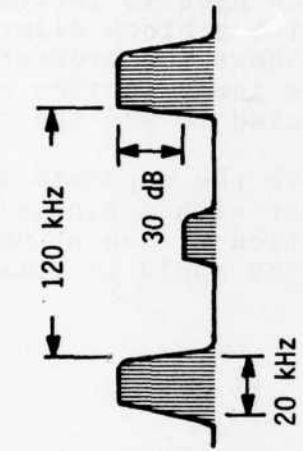

30 MHz FM
OSCILLATOR
+10 kHz
DEVIATION

FIGURE 23
GENERATION OF STRADDLE PILOT

3. SEPARATE RF AND IF PILOTS

Some tests were also run with separate RF and IF pilots. The PSK pilot was kept for the IF ICS, but a CW pilot was used for the RF ICS. The CW pilot was kept outside the 100 kHz band to prevent interaction with the transmitted signal in the RF ICS.

The breadboard modification used to implement a separate RF pilot is shown in Figure 24 with a block diagram of Box M'. The upper section of the figure shows the present setup in the system using a single pilot. The lower section of the figure shows the additional components used to add the second pilot.

Cancellation tests run with the separate RF and IF pilots showed performance similar to that with a single pilot. The same limitations of noise modulation of the RF weight and third-order nonlinearity in the RF weight apply to both cases.

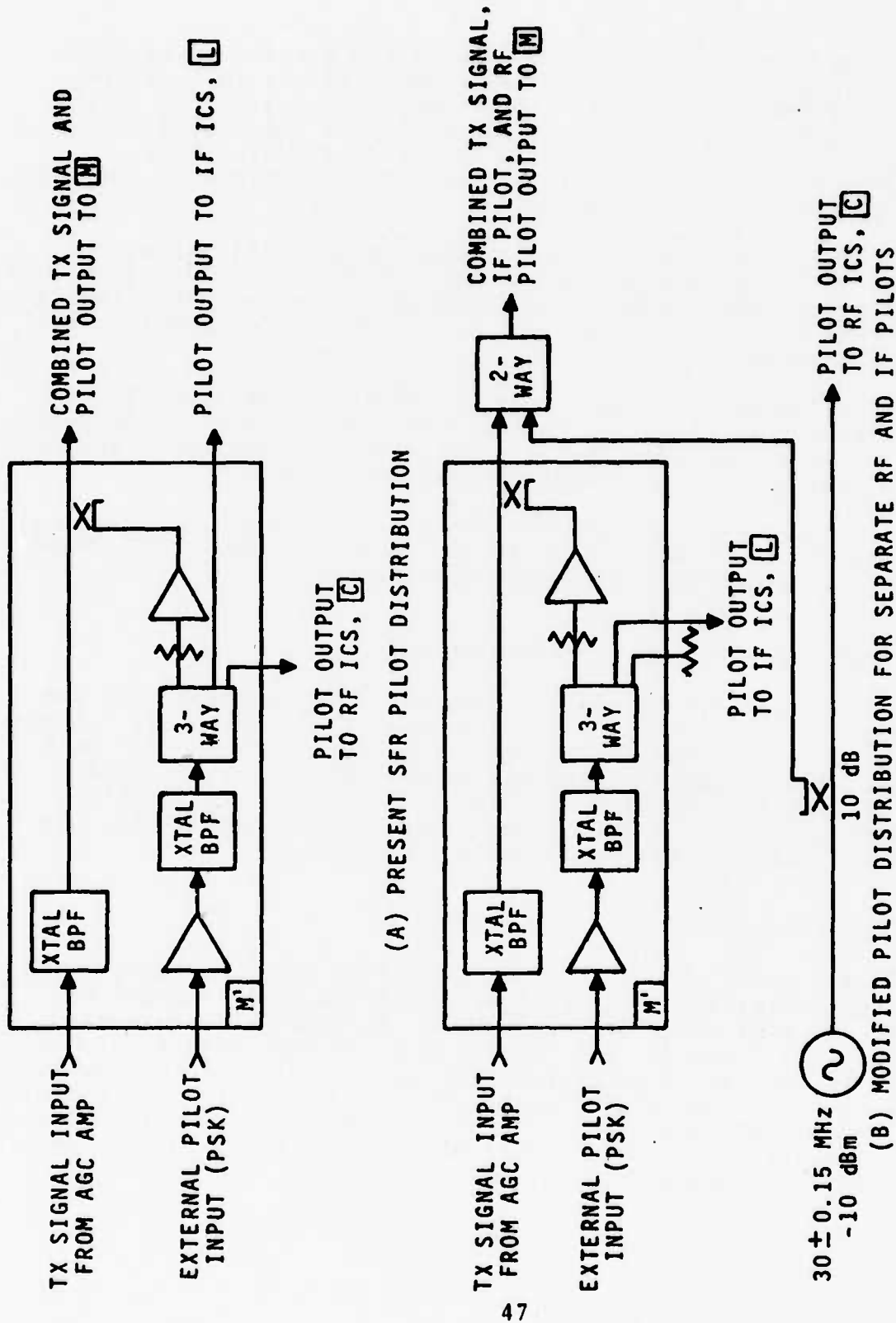

FIGURE 24
IMPLEMENTATION OF SEPARATE RF AND IF ICS PILOTS

SECTION VII

RECOMMENDATIONS FOR FURTHER WORK

The experiments on the modified SFR breadboard have uncovered areas in which further work would result in improved SFR performance. They are: reduction of circuit noise in the RF ICS weight control unit, linearization of the RF ICS weight, and further investigation of the use of a straddle pilot. Recommended approaches for effecting these improvements are outlined in the subsections below.

It is believed that these improvements will allow the present 102 dB of forward gain to be achieved with less than 2 dB ripple across the 100 kHz band and without the momentary lapses in cancellation. It should also be possible to extend the forward gain capability to 110 dB.

Following these improvements, further laboratory tests should be run to establish the new performance levels. At that point it is recommended that field tests be conducted on the SFR with a real antenna in a real terrain environment.

Another area of investigation is also proposed. That is, widening the SFR bandwidth to allow relaying of more narrowband channels or relaying spread spectrum signals.

1. CIRCUIT NOISE IN THE RF WEIGHT CONTROL UNIT

The most likely circuit components to be generating the control unit circuit noise are the operational amplifiers. There are improved versions presently on the market which offer much improved low frequency noise characteristics (e.g., products made by Precision Monolithics, Inc.). Some are pin-for-pin replacements of the currently used operational amplifiers, and do not sacrifice other performance features.

2. LINEARIZATION OF THE RF ICS WEIGHT

Two areas should be investigated in order to improve the RF weight linearity. First, individual PIN diodes should be tested in order to select those with the minimum third-order nonlinearity. Second, the design of the weight driver circuit should be reexamined experimentally to determine if the two DC drive currents into the PIN diode network are optimized to provide minimum third-order nonlinearity. The third-order performance measured with the original RF weight breadboard provides an achievable target for this experiment.

3. STRADDLE PILOT

Further experimentation with a straddle pilot should be conducted. Because this pilot straddles the transmitted signal band, the interaction between the pilot and the transmitted signal in the ICS control loops is greatly reduced. This allows the loop bandwidth to be widened, providing greater ability to track out the circuit noise effects.

The straddle pilot experiment discussed in Section VI.2 used FM sidebands. Figure 25 shows a means of implementing a straddle pilot with the two sidebands originating from a PN-BPSK source.

4. FIELD TEST

After the above improvements have been incorporated into the SFR, laboratory tests should be run to establish the new performance levels. At that point, the SFR should be field-tested with a real antenna in a real terrain environment.

A field test diagram is shown in Figure 26, with spacing between antennas of 50 or 100 meters. Using these relatively short transmission distances allows one test team to operate all the equipment. Path loss attenuation is simulated by coaxial attenuators in line with the source transmitter antenna and the final receive antenna. The objectives accommodated by this test would be:

- a. Measure forward gain and demonstrate suitability for AM voice channels in outdoor environment.
- b. Measure effects of reflecting terrain on SFR performance.
- c. Test SFR use for multiple channel relaying.
- d. Demonstrate dynamic range of SFR.

5. INCREASED BANDWIDTH

Increasing the SFR bandwidth from the present value of 100 kHz will allow greater utility in relaying more channels or accommodating spread spectrum signals. The pilot bandwidth would be similarly increased, as would the IF filter bandwidths and the bandwidths of the notch filters in the IF ICS.

As bandwidth is increased, the achievable SFR forward gain in a real environment decreases.* For example, with 100 kHz

*See Section II of RADC-TR-76-78, "Adaptive SFR Study," March 1976.

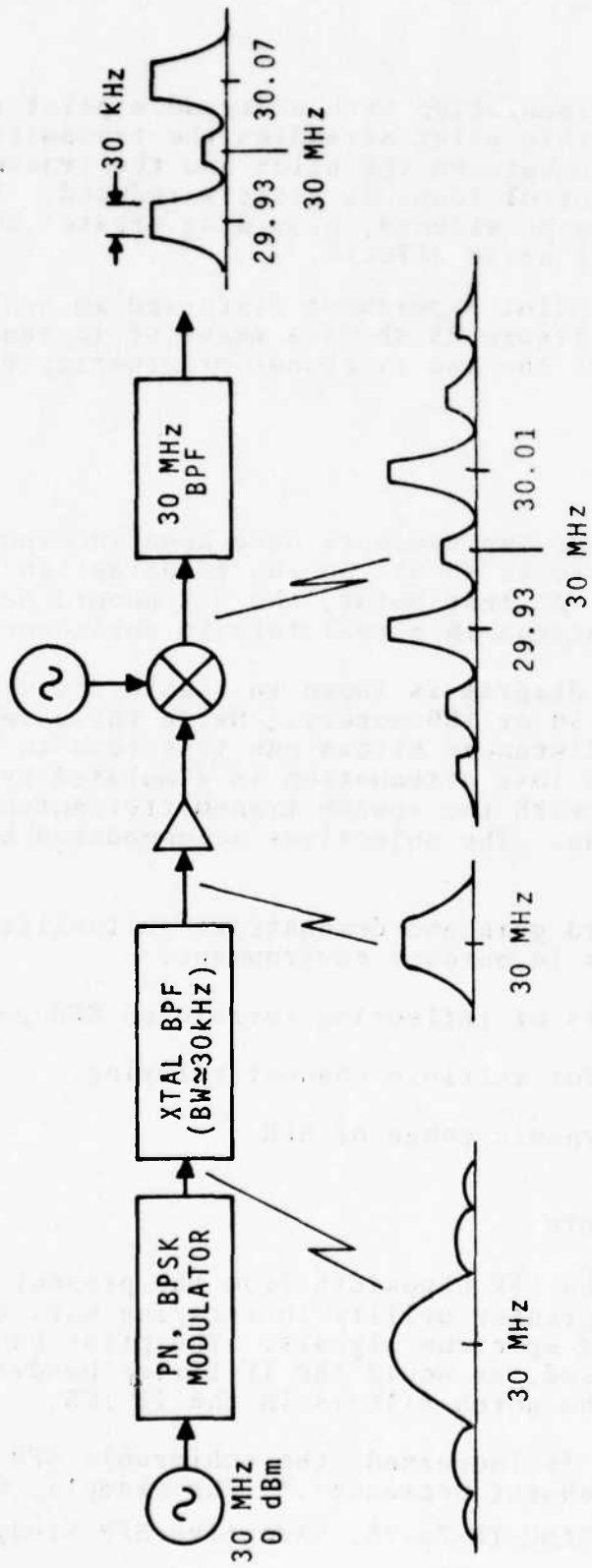

FIGURE 25
GENERATION OF A STRADDLE PILOT WITH PN BPSK SIDEBANDS

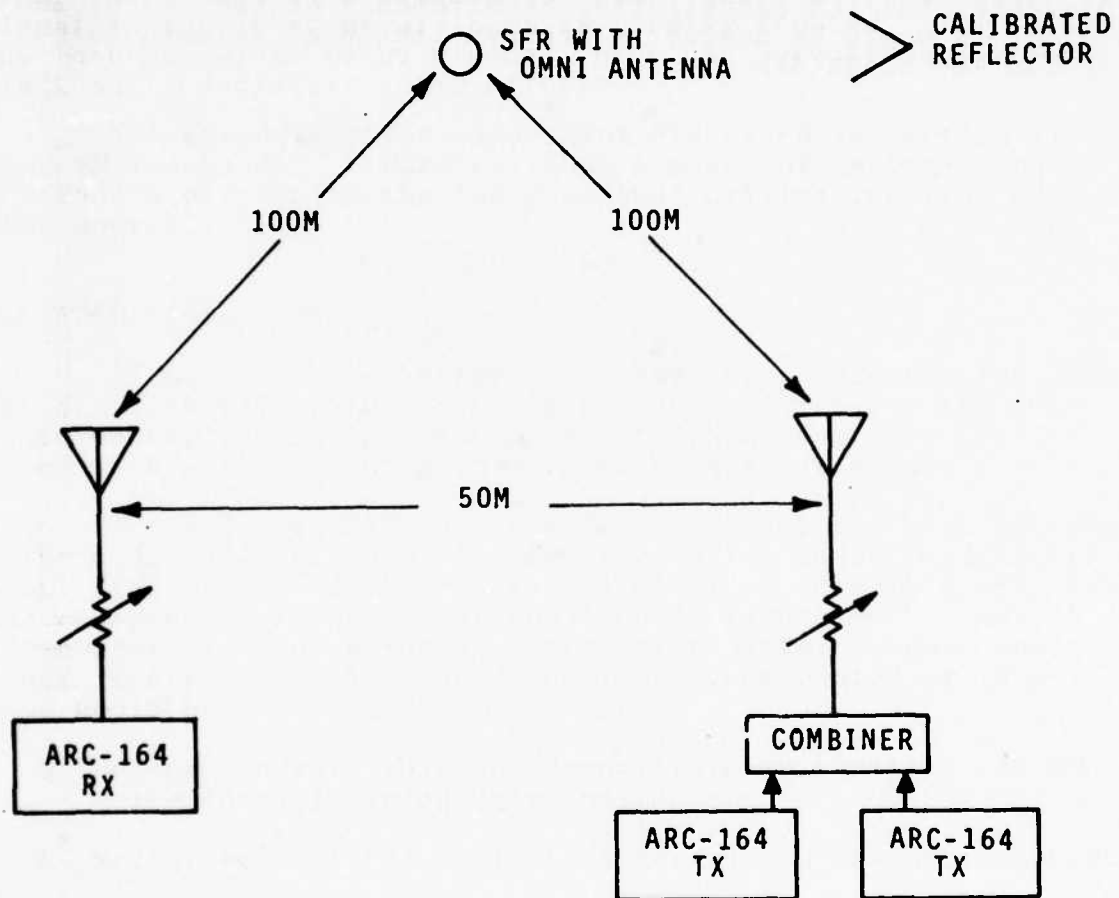

FIGURE 26
SFR FIELD TEST

bandwidth, the transmit-to-receive isolation is limited to 116 dB by ground clutter effects. For 1 MHz bandwidth, the Tx/Rx isolation drops to 96 dB. Since only 96 dB of forward gain is achievable, the ICS cancellation requirements on the ICS are not as great as would be needed to achieve 110 dB of forward gain with 100 kHz bandwidth.



SECTION VIII

SUMMARY AND CONCLUSIONS

Improvements were made in the SFR breadboard model to increase its forward gain from 67 dB to 102 dB. These improvements were in the nature of circuit modifications. The basic system structure, and the concepts on which it was founded, remained intact.

The modifications incorporated into the SFR breadboard were:

- a. IF notch filters inserted into the RF front end to prevent IF ring-around,
- b. Isolation of the transmitted signal from the pilot lines to ensure that the ICS's are controlled strictly by the pilot,
- c. Redistribution of gain in the IF ICS control loops to reduce the cancellation limit imposed by DC offsets,
- d. Decreasing the AGC time constant so that AM signals may be relayed without distortion,
- e. Improved isolation from power supply ripple of the drivers for the RF complex weight,
- f. Redesign of the notch filter chains for the IF ICS to narrow the notch bandwidth from 2 MHz to 300 kHz without sacrificing notch depth.

Investigations were carried out to determine those factors which limit the SFR forward gain to its present level of 102 dB when used with a common antenna for transmission and reception. The limiting factors are those which limit the cancellation performance of the ICS's. The first is the third-order nonlinearity of the RF ICS complex weight which slightly changes the ratio of the transmitted signal and the pilot waveforms passing through it. Thus, even with perfect cancellation of the pilot, some residue of the transmitted signal would still remain uncanceled. The second is circuit noise in the RF ICS control loop which imposes a low level noise modulation on the signals passing through the RF ICS complex weight. The IF ICS is not fast enough to follow this noise modulation because its closed loop bandwidth is constrained to be narrow to prevent an interaction between the pilot and transmitted signal in the ICS loop which would severely degrade cancellation.

Further modifications to the breadboard to overcome these limitations have been outlined. After further performance refinement, the SFR breadboard should be field-tested, where natural reflecting terrain will provide a far more realistic performance test than can be accomplished in the laboratory.

ACRONYMS AND PRINCIPAL SYMBOLS

B_{CL}	= ICS closed loop bandwidth
B_p	= pilot bandwidth
BPF	= bandpass filter
C	= control unit for complex weight
e_i	= reference input voltage
e_c	= voltage at ICS output
F(S)	= bandpass filter transfer function
$G_{SFR}(dB)$	= SFR forward gain in dB
H(S)	= notch filter transfer function
ICS	= Interference Cancellation System
K	= gain factor in notch filter circuit
k_3	= coefficient of the cubic term in a power law expansion describing the weight nonlinearity
$P_{GEN}(dBm)$	= generator output power level in dBm
P_p	= power level of the pilot signal
$P_{SA}(dBm)$	= power level into the spectrum analyzer in dBm
P_T	= power level of the transmitted signal
Q_L	= loaded quality factor of a resonator
Q_U	= unloaded quality factor of a resonator component
SFR	= Same-Frequency Repeater
V_{CT}	= amplitude of cancelled transmitted signal
V_p	= amplitude of the pilot
V_T	= amplitude of the transmitted signal
W	= complex weight value
α	= complex scale factor that relates the main input level of the ICS to its reference input level
ω_0	= center frequency in radians per second of the notch filter
ω_p	= pilot frequency in radians per second
ω_T	= transmitted signal frequency in radians per second

APPENDIX A
CIRCUIT SCHEMATICS

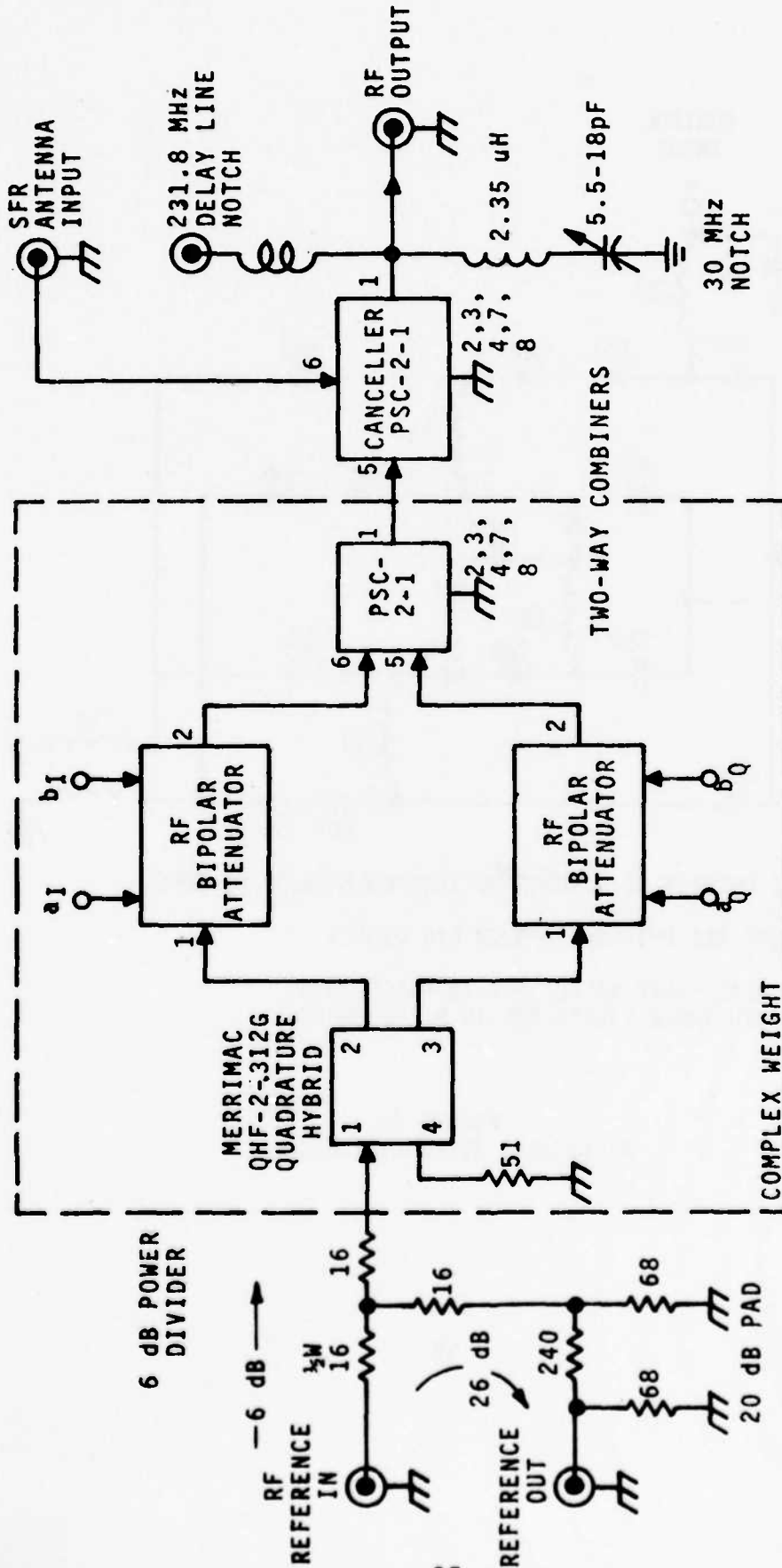
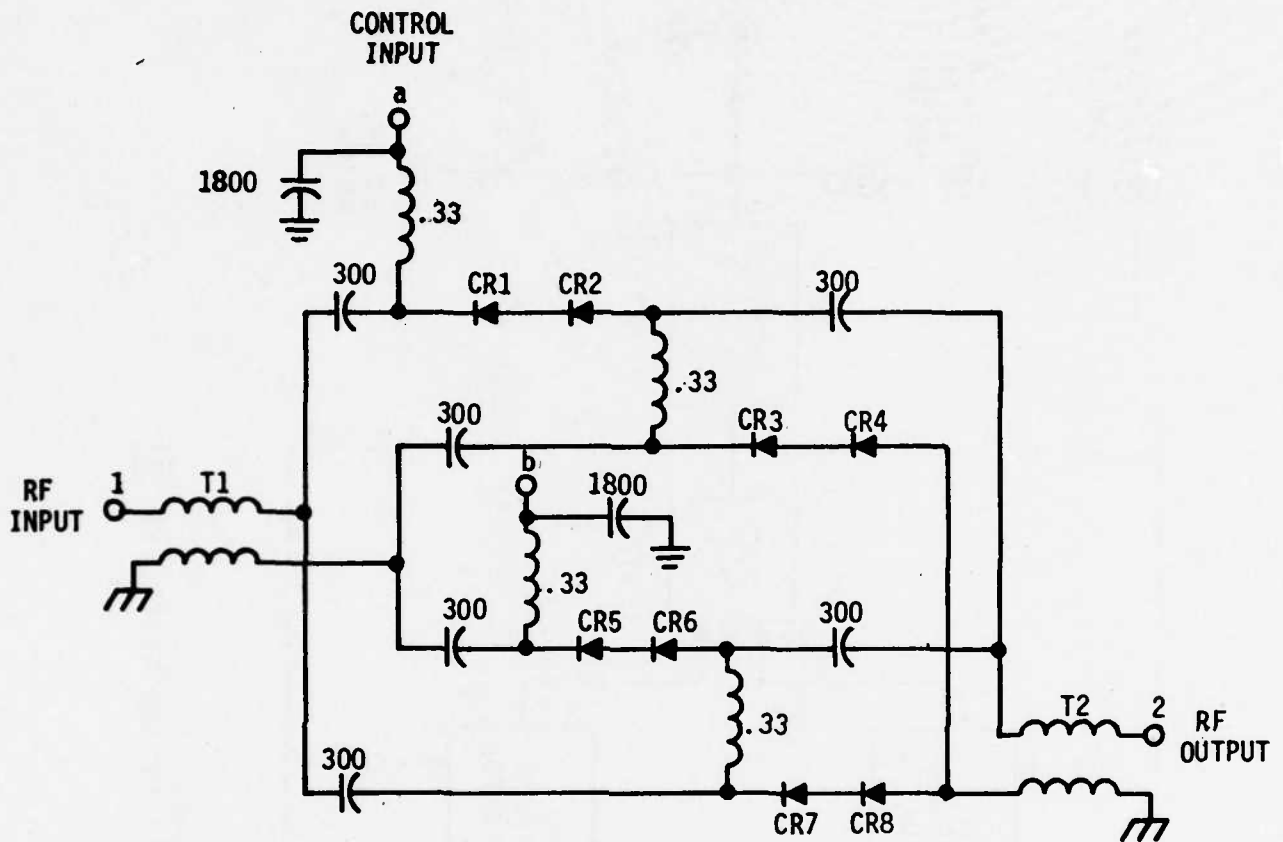

FIGURE 27
RF ICS COMPLEX WEIGHT AND CANCELLER [A]



T1-T2 CONSIST OF 3 TURNS*30 TWISTED PAIR ON Q1 CORE

CR1-CR8 ARE UNITRODE UM9303 PIN DIODES

ALL CAPACITANCE VALUES ARE IN PICO FARADS
ALL INDUCTANCE VALUES ARE IN MICROHENRIES

FIGURE 28
RF BIPOLAR ATTENUATOR CIRCUIT

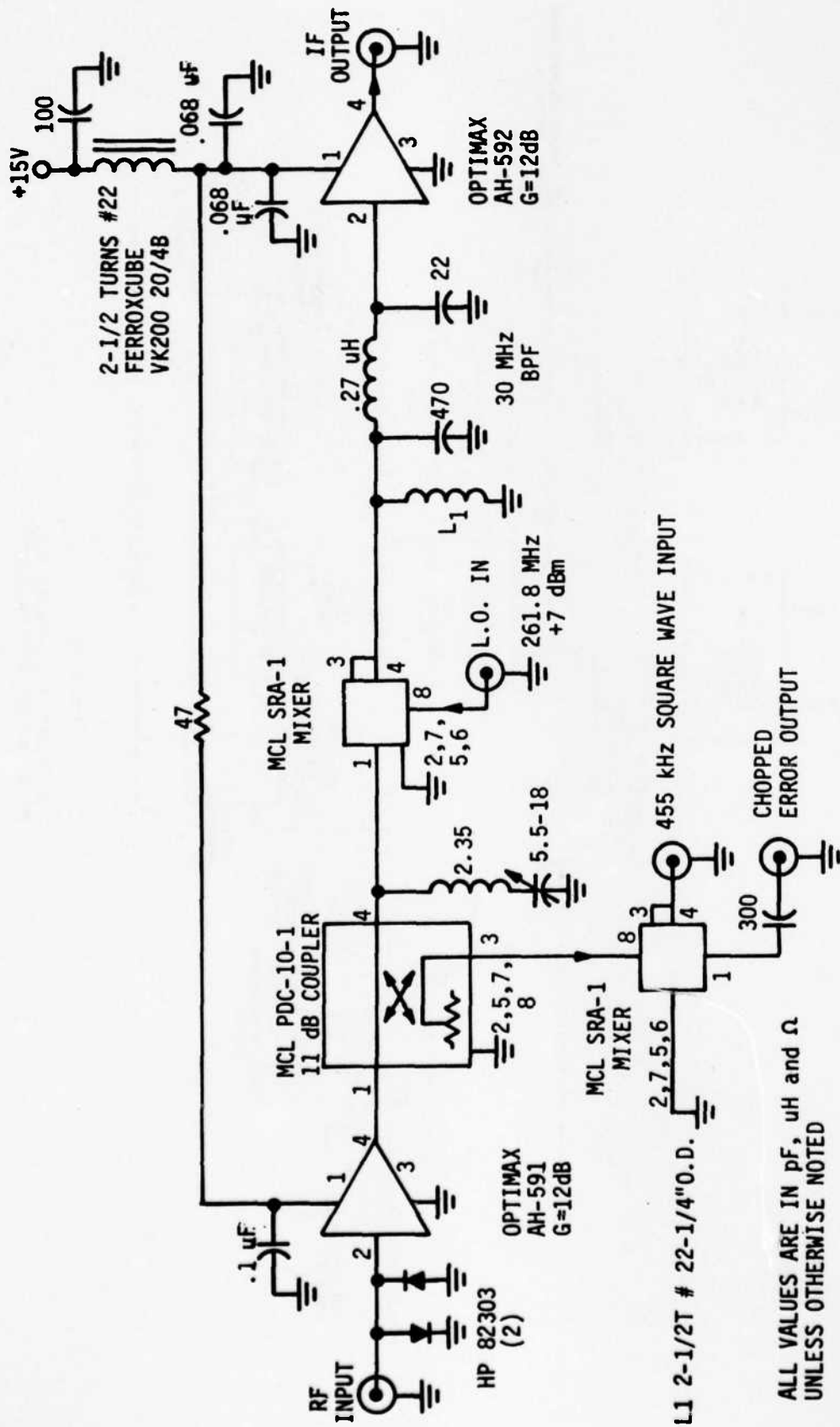

ALL VALUES ARE IN pF, uH and Ω UNLESS OTHERWISE NOTED

FIGURE 29
RF PREAMP AND DOWN CONVERTER **B**

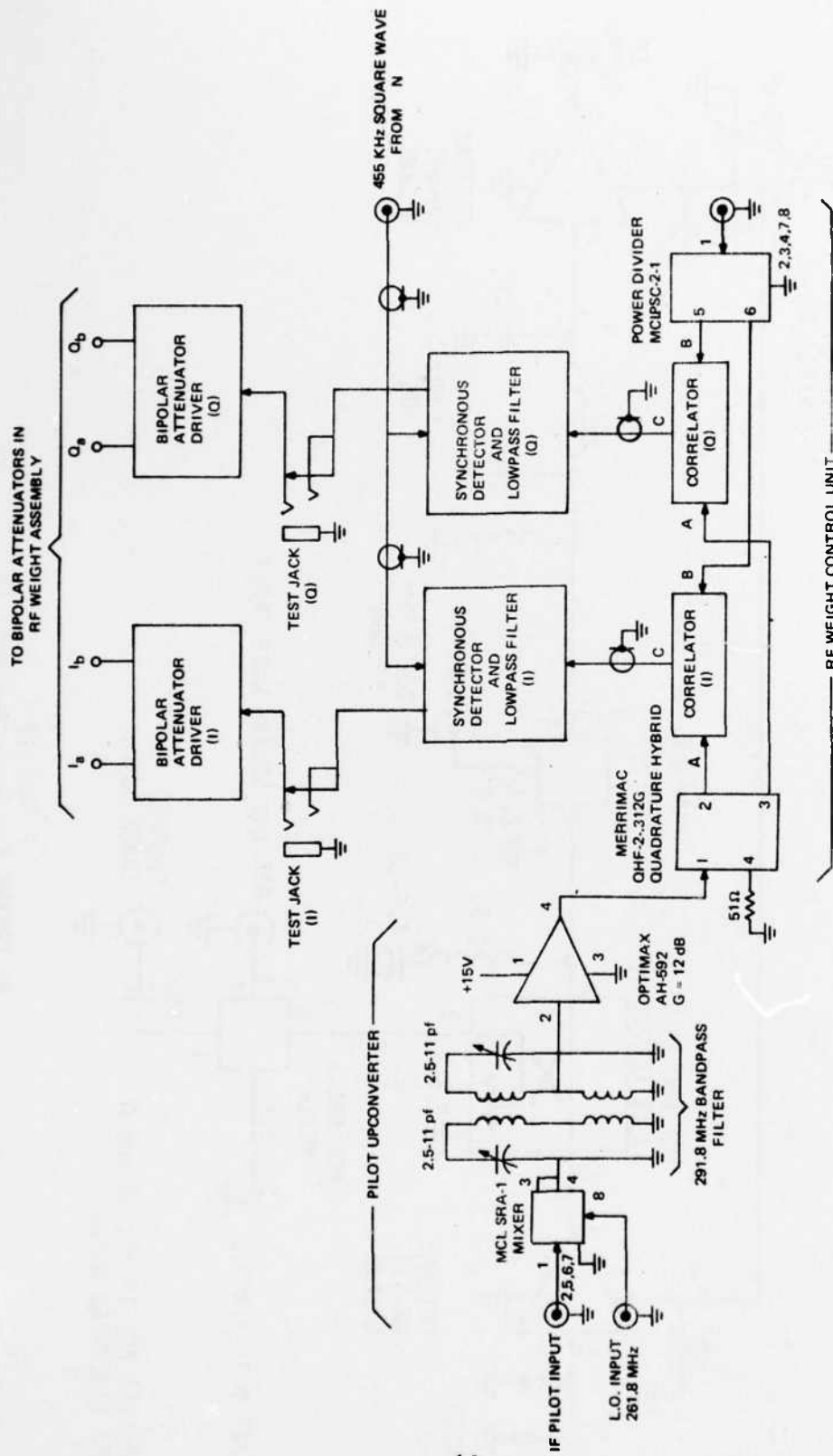

FIGURE 30

SFR PILOT UP CONVERTER AND RF ICs WEIGHT CONTROL UNIT [C]

COMPONENT	VALUE	
	RF CORRELATOR	IF CORRELATOR
C1	300 pf	1000 pf
C2	.15 uf	.15 uf
C3	.15 uf	.15 uf
C4	.15 uf	.15 uf
C5	300 pf	1000 pf
C6	.15 uf	.15 uf
C7	300 pf	1000 pf

CR1 - CR4 ARE FAIRCHILD FH1100

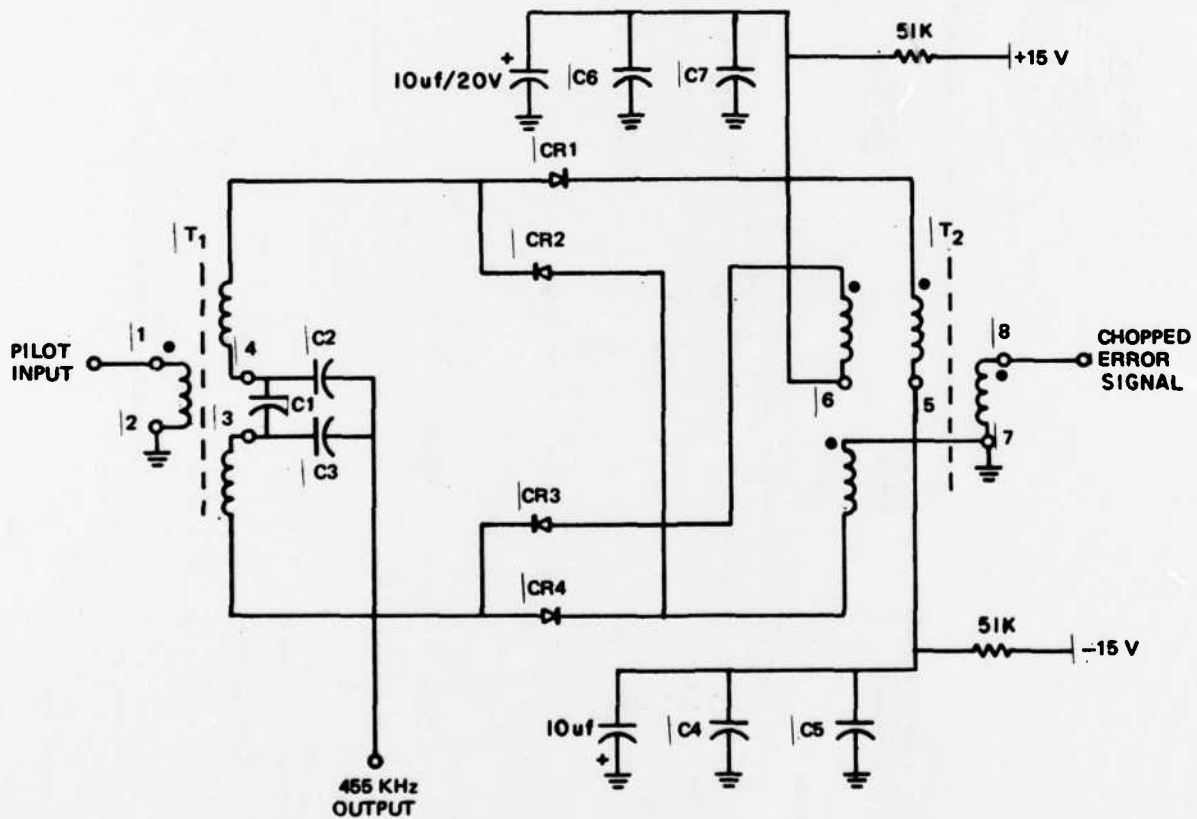

FIGURE 31
RF AND IF CORRELATORS
(USED IN RF AND IF WEIGHT CONTROL UNITS)

CANCELLER	R _f	C _f	R ₁
RF (C)	3.3M	10 μ f	10K
IF-1 (I)	3.3M	4 μ f	150
IF-2 (J)	3.3M	10 μ f	30K
IF-3 (K)	330K	10 μ f	3K

SEE CHART ABOVE
FOR R₁, R_f, C_f

NOTES
1. THE 733 OUTPUT IS TAKEN FROM PIN 7 ONLY IN THE O CHANNEL OF THE IF CANCELLERS

UNLESS OTHERWISE SPECIFIED:
ALL RESISTANCE VALUES ARE IN OHMS, $\pm 5\%$ 1/4 W
ALL CAPACITANCE VALUES ARE IN μ F
ALL INDUCTANCE VALUES ARE IN μ H

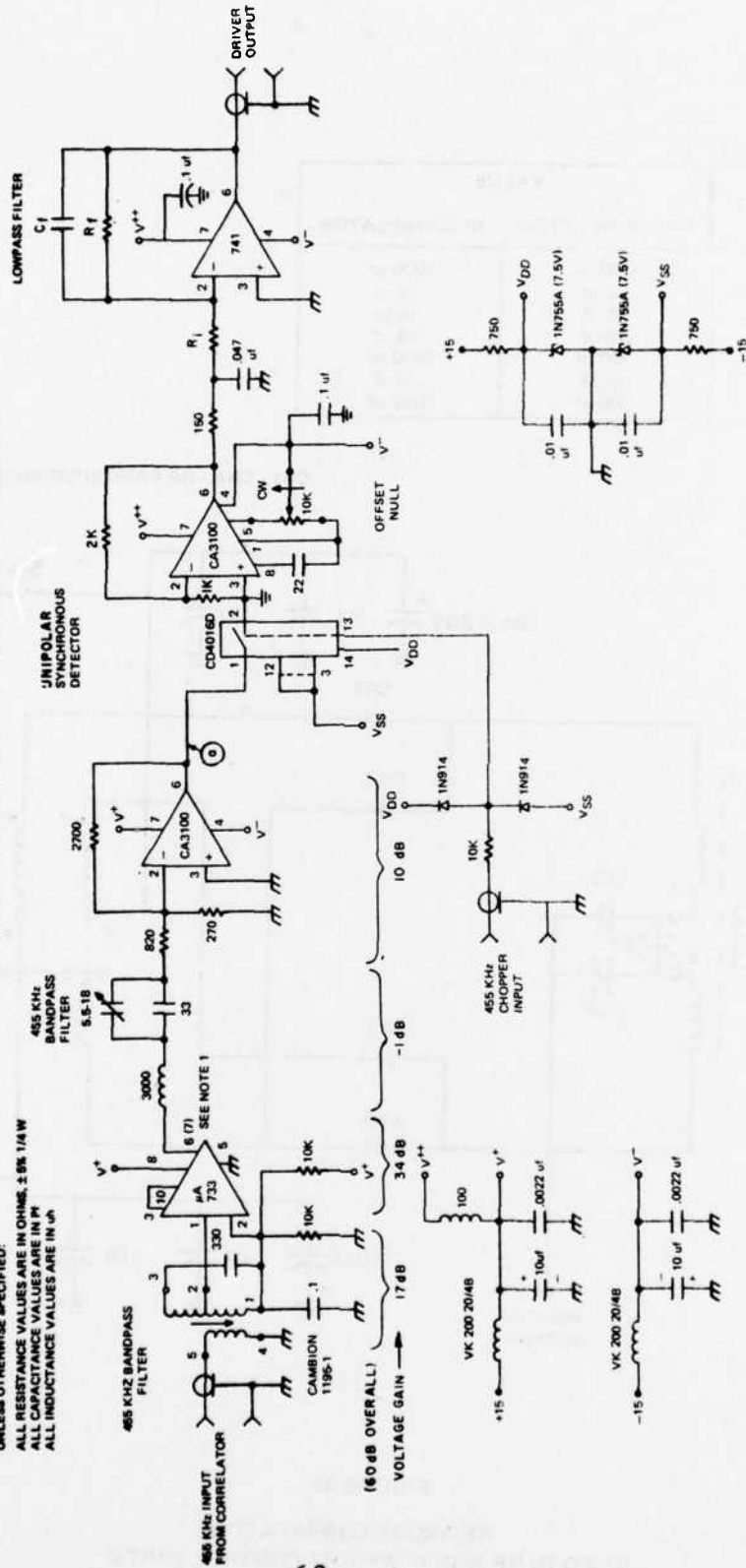
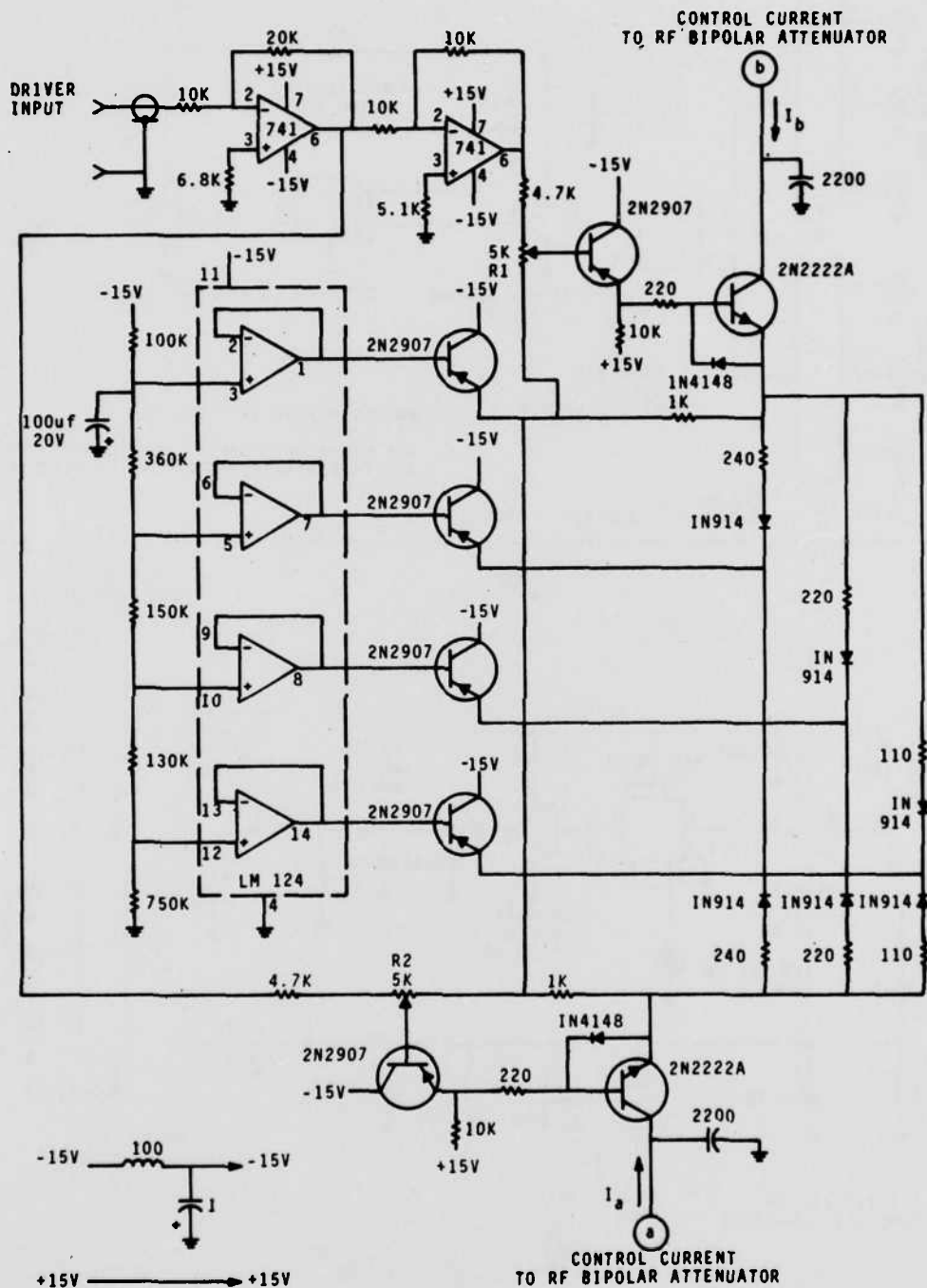
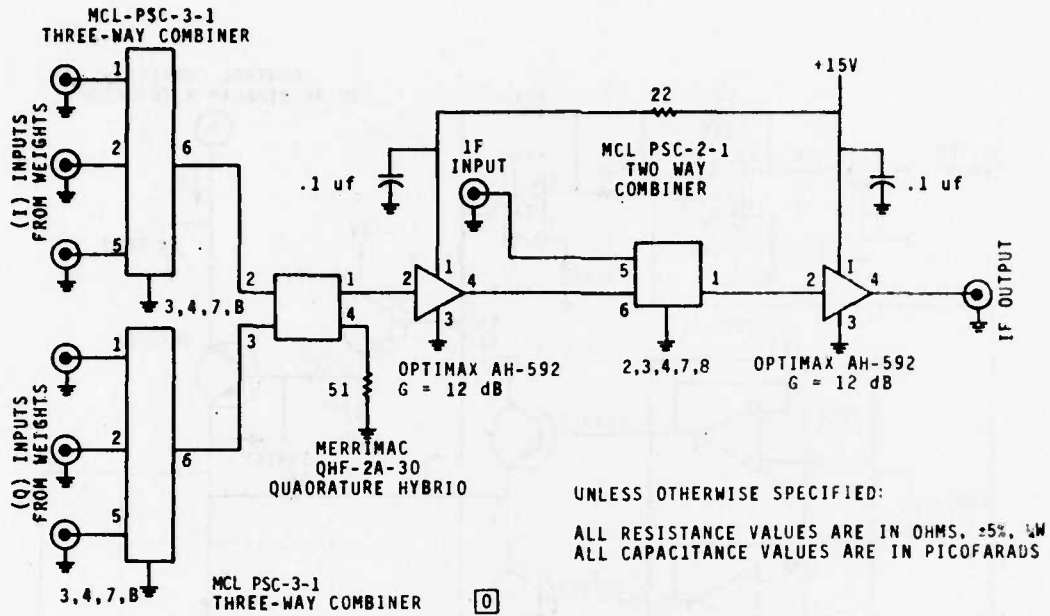

FIGURE 32
SFR SYNCHRONOUS DETECTOR AND LOWPASS FILTER



UNLESS OTHERWISE SPECIFIED:
 ALL RESISTANCE VALUES ARE IN OHMS, $\pm 5\%$, $\frac{1}{4}$ W
 ALL INDUCTANCE VALUES ARE IN μ h, $\pm 10\%$
 ALL CAPACITANCE VALUES ARE IN μ f, $\pm 10\%$

FIGURE 33
 RF BIPOLAR ATTENUATOR DRIVER



D

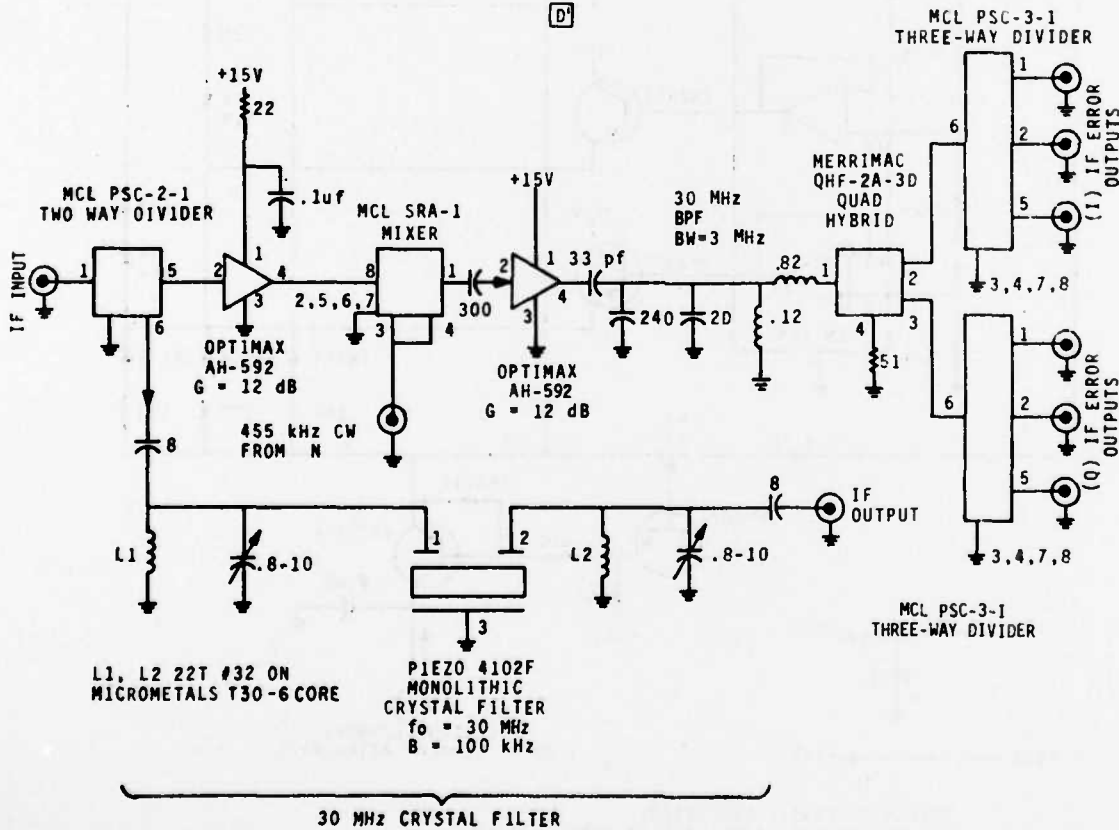

FIGURE 34
SFR IF CANCELLER AND ERROR SIGNAL OISTRIBUTION

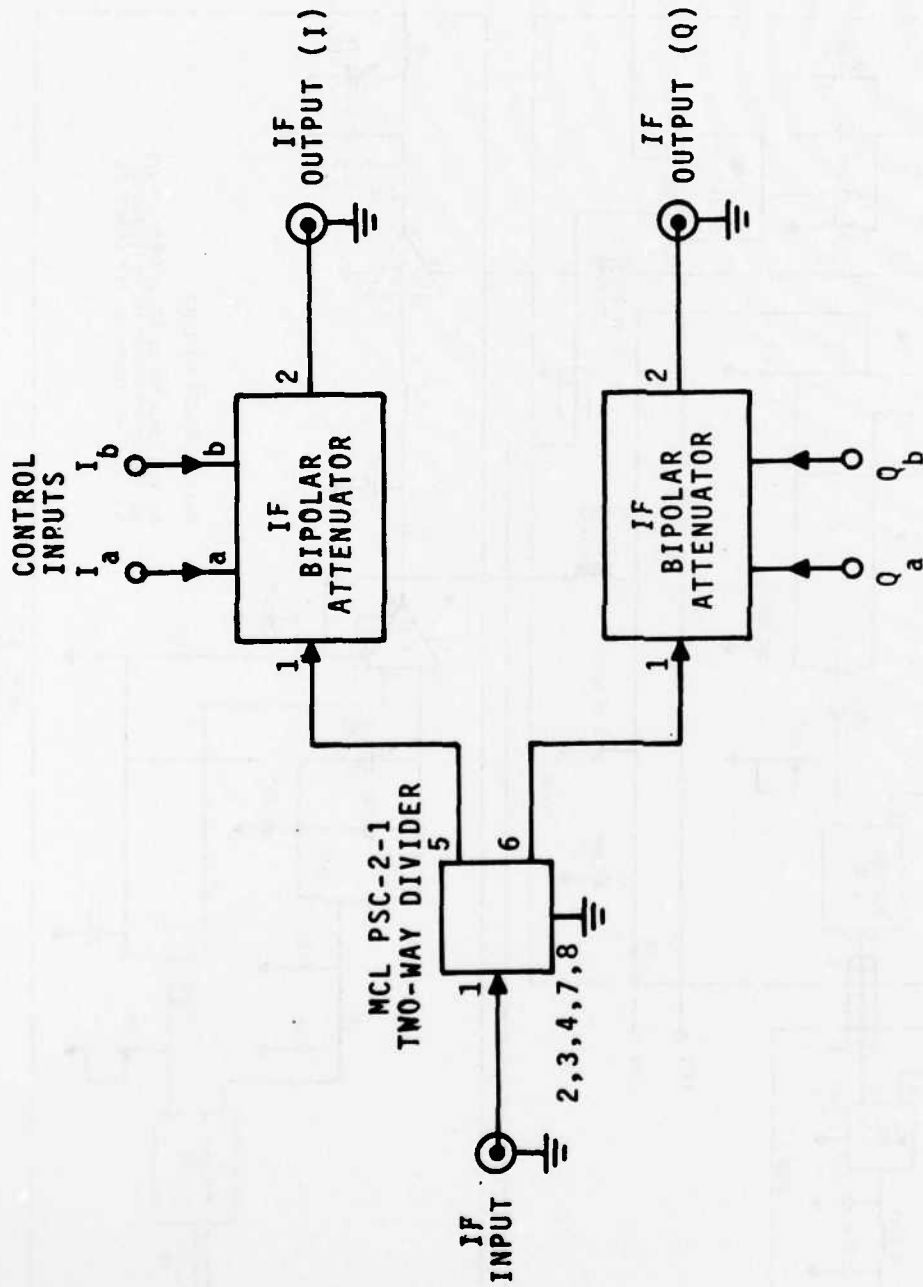

FIGURE 36
F G H SFR IF WEIGHT ASSEMBLY

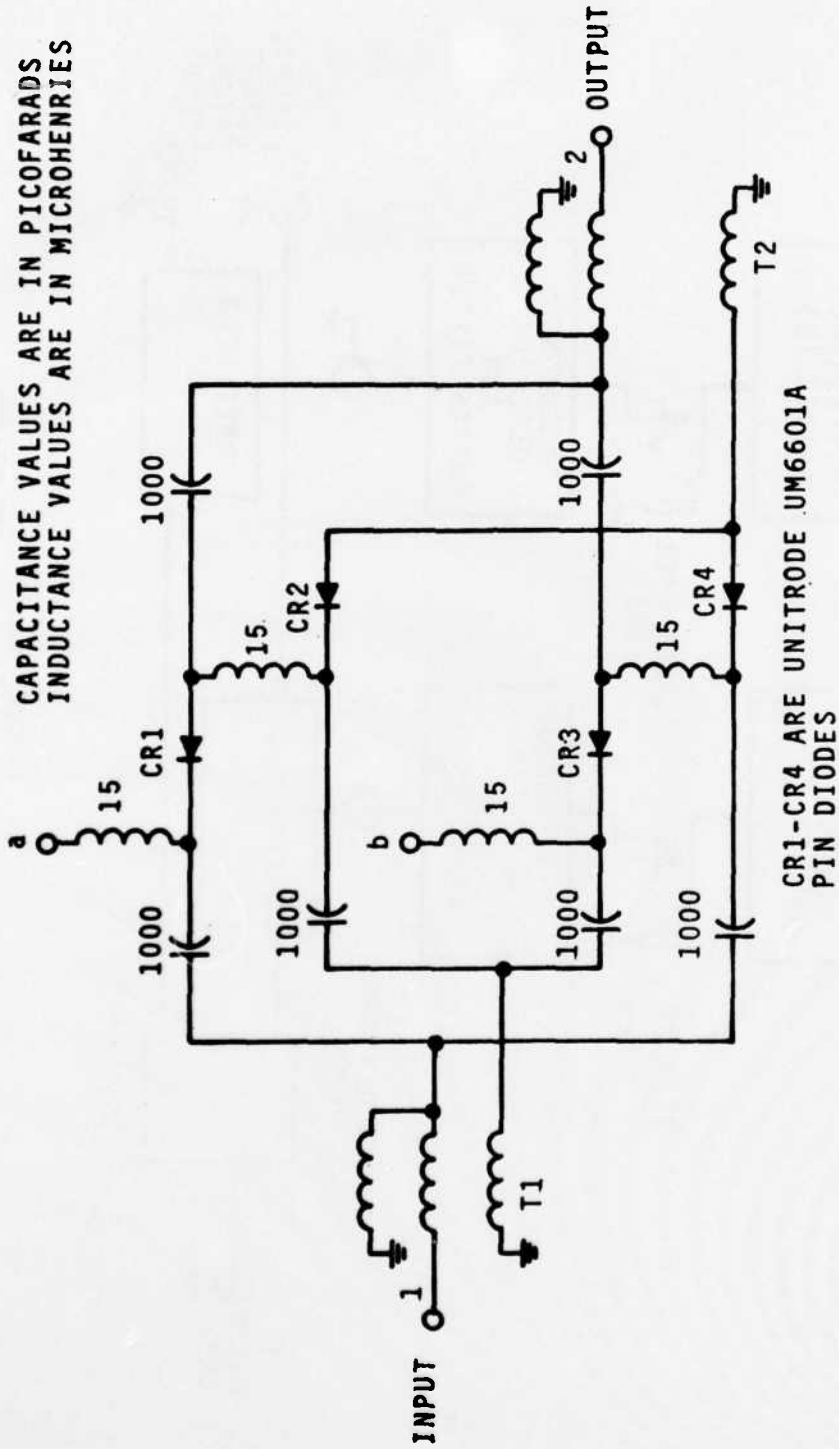

FIGURE 37
IF BIPOLAR ATTENUATOR CIRCUIT

TO BIPOLAR ATTENUATORS IN IF WEIGHT ASSEMBLY

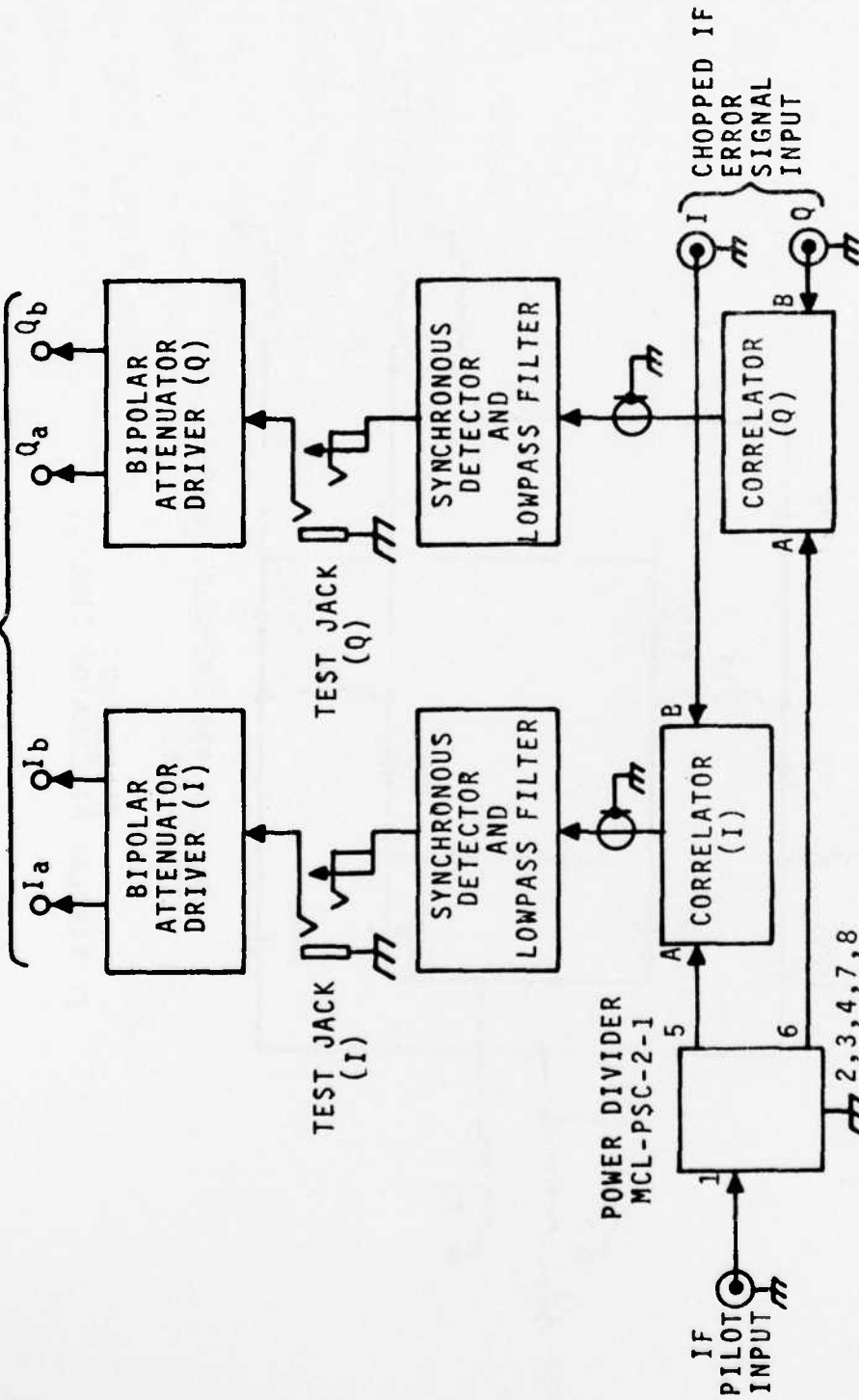

FIGURE 38
IF ICS WEIGHT CONTROL UNITS I J K

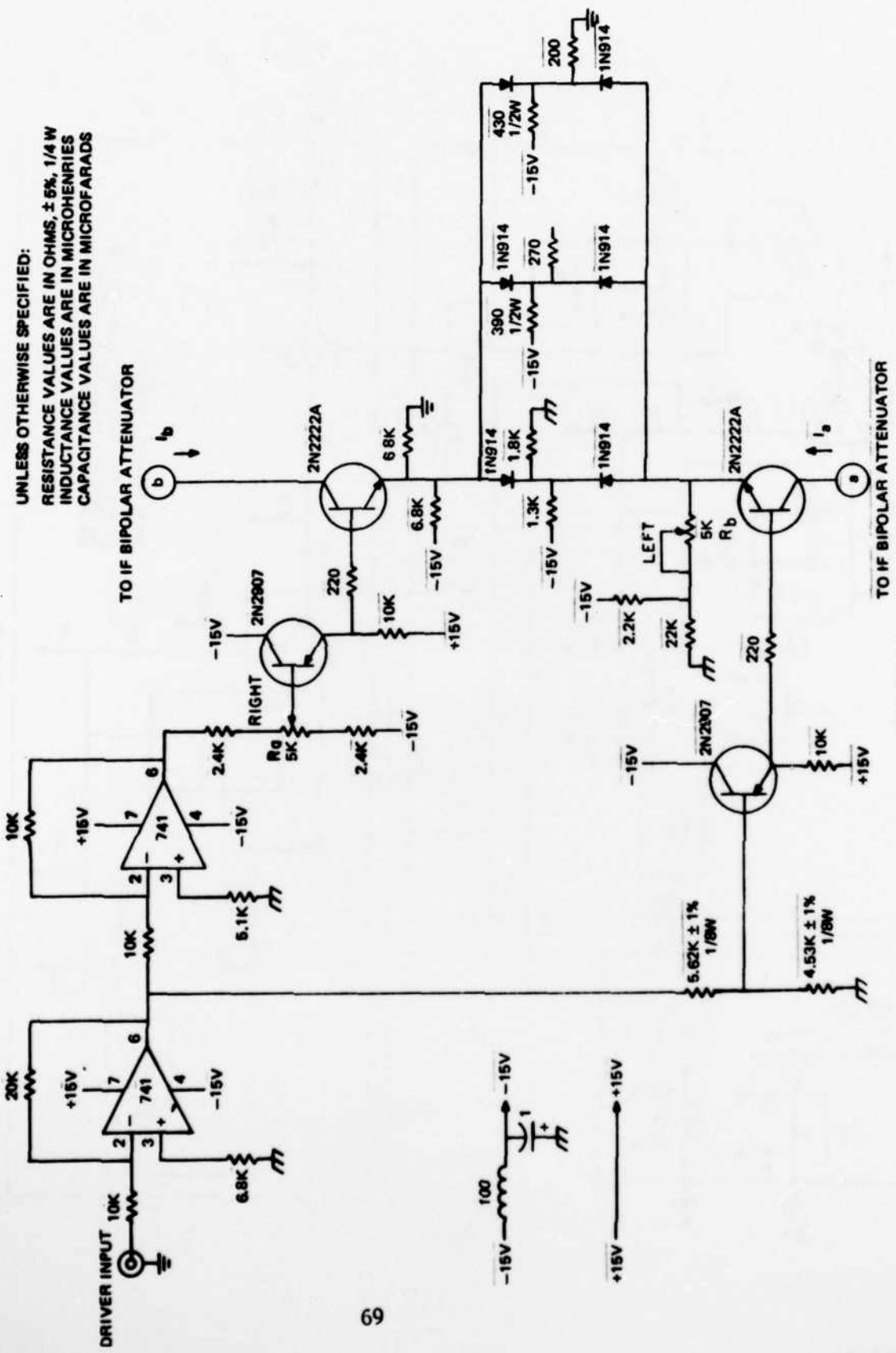
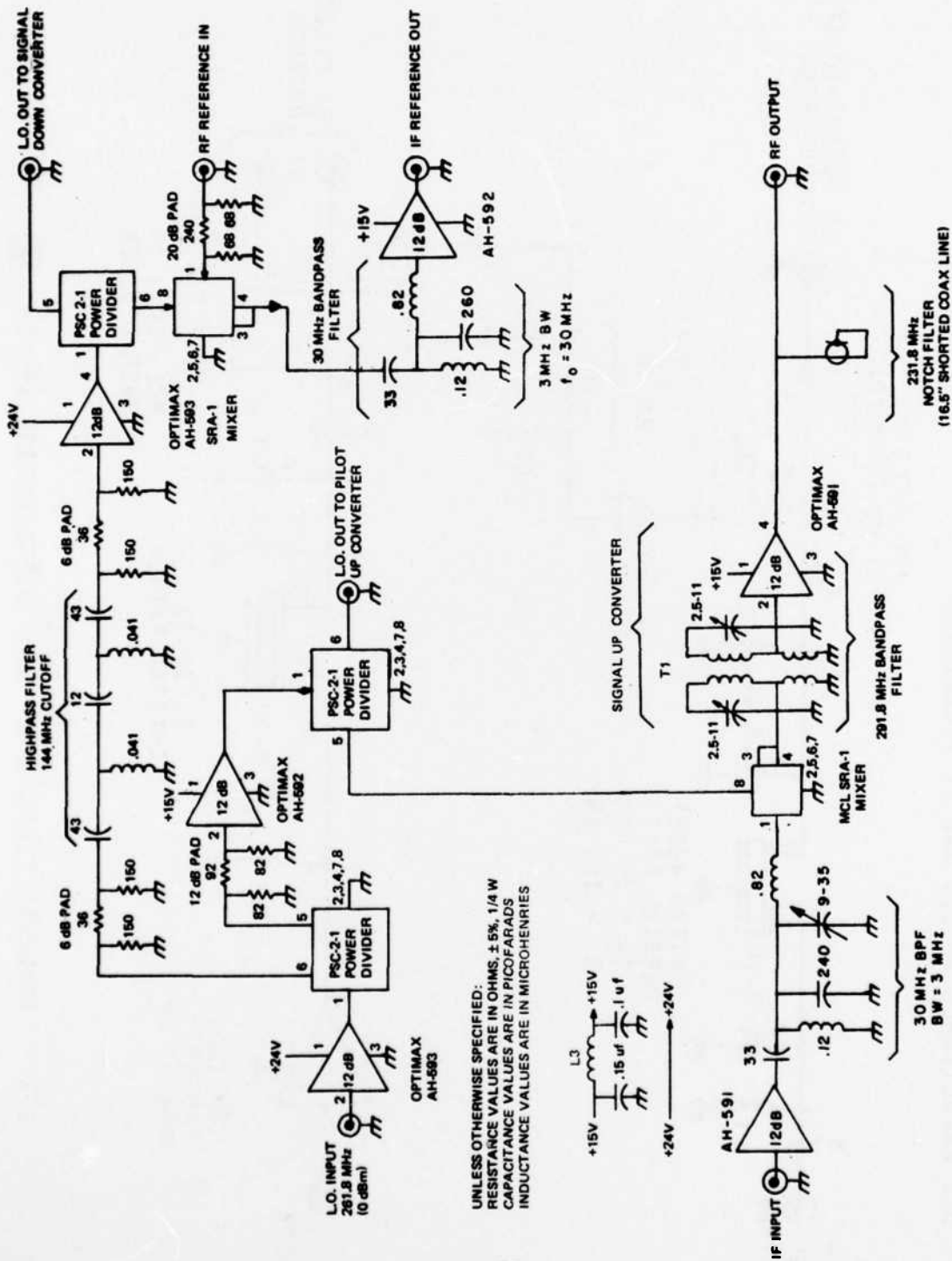

FIGURE 39
 IF BIPOLAR ATTENUATOR DRIVER



UNLESS OTHERWISE SPECIFIED:
 RESISTANCE VALUES ARE IN OHMS, ±5%, 1/4 W
 CAPACITANCE VALUES ARE IN PICOFARADS
 INDUCTANCE VALUES ARE IN MICROHENRIES

FIGURE 41
 SFR SIGNAL UP-CONVERTER, LOCAL OSCILLATOR
 DISTRIBUTION AND REFERENCE DOWN-CONVERTER

L1-L4: 22T #32 WIRE ON
 MICROMETALS T30-6 CORE
 ALL CAPACITANCE VALUES ARE IN PICOFARADS

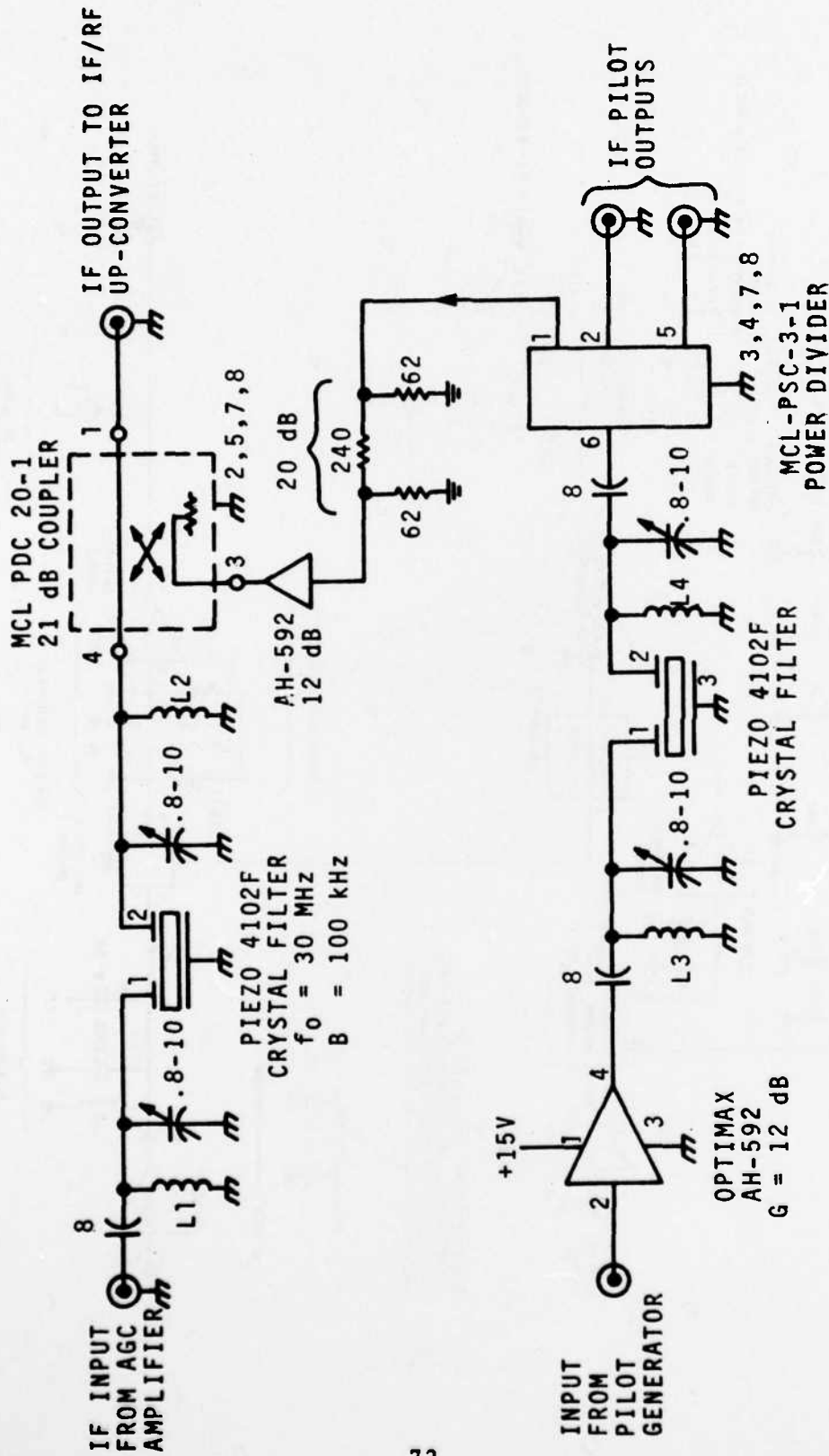

FIGURE 42
 SFR IF BANDPASS FILTER AND PILOT DISTRIBUTION SYSTEM [M]

DATE
FILME