

AD A 0 4 7 4 9 3

**PROCEDURES MANUAL**

*12*  
*B.S.*

**DYNAMIC STABILITY ANALYSIS  
FOR  
U.S. NAVY SMALL CRAFT**

**Approved for Public Release  
Distribution Unlimited**

**COMBATANT CRAFT ENGINEERING  
NAVAL SHIP ENGINEERING CENTER, NORFOLK DIVISION  
NORFOLK, VIRGINIA**

**AD No. \_\_\_\_\_  
DDC FILE COPY**

**January 1977**

**ASSET Incorporated  
REPORT NO. 23095-1**

**DDC  
RECEIVED  
DEC 8 1977  
RECEIVED**

UNCLASSIFIED

SECURITY CLASSIFICATION OF THIS PAGE (When Data Entered)

| REPORT DOCUMENTATION PAGE   |   | READ INSTRUCTIONS<br>BEFORE COMPLETING FORM |
|---|---|---|
| 1. REPORT NUMBER<br>14 23095-1  | 2. GOVT ACCESSION NO.   | 3. RECIPIENT'S CATALOG NUMBER               |
| 4. TITLE (and Subtitle)<br>6 Procedures Manual-<br>Dynamic Stability Analysis for U.S. Navy<br>Small Craft  | 5. TYPE OF REPORT & PERIOD COVERED<br>9 Final<br>Technical Report |   |
|   | 6. PERFORMING ORG. REPORT NUMBER                                  |   |
| 7. AUTHOR(s)<br>10 Joseph G. Koelbel, Jr  | 8. CONTRACT OR GRANT NUMBER(s)<br>15 N00189-74-A-0229             |   |
| 9. PERFORMING ORGANIZATION NAME AND ADDRESS<br>ASSET, Inc.<br>8550 Arlington Blvd.<br>Fairfax, VA 22030   | 10. PROGRAM ELEMENT, PROJECT, TASK<br>AREA & WORK UNIT NUMBERS    |   |
| 11. CONTROLLING OFFICE NAME AND ADDRESS<br>Naval Sea Systems Command (PMS 300)<br>Washington, DC 20362  | 12. REPORT DATE<br>11 January 1977                                | 13. NUMBER OF PAGES<br>78 1280p.            |
| 14. MONITORING AGENCY NAME & ADDRESS (if different from Controlling Office)<br>Naval Ship Engineering Center<br>Norfolk Division<br>Norfolk, VA 23511   | 15. SECURITY CLASS. (of this report)<br>Unclassified              |   |
|   | 15a. DECLASSIFICATION/DOWNGRADING<br>SCHEDULE                     |   |
| 16. DISTRIBUTION STATEMENT (of this Report)<br>Approved For Public Release: Distribution Unlimited  |   |   |
| 17. DISTRIBUTION STATEMENT (of the abstract entered in Block 20, if different from Report)  |   |   |
| 18. SUPPLEMENTARY NOTES<br>Sponsored by the Naval Sea Systems Command Combatant Craft Improvement<br>Program  |   |   |
| 19. KEY WORDS (Continue on reverse side if necessary and identify by block number)<br>Small Craft<br>Dynamic Stability  |   |   |
| 20. ABSTRACT (Continue on reverse side if necessary and identify by block number)<br>This manual presents the procedures and background information necessary<br>to perform a transverse dynamic stability analysis of U.S. Navy small craft.<br>The manual is intended for use by new engineers and technicians who might not<br>be familiar with the stability aspects of Naval Architecture. The procedure<br>has been ordered and sequenced (and work sheets provided) so that the analysis<br>can be performed, comparison made with stability criteria, and conclusions<br>(OVER) |   |   |

DD FORM 1 JAN 73 1473

EDITION OF 1 NOV 65 IS OBSOLETE  
S/N 0102-014-6601

UNCLASSIFIED 407442  
SECURITY CLASSIFICATION OF THIS PAGE (When Data Entered)

UNCLASSIFIED

SECURITY CLASSIFICATION OF THIS PAGE(When Data Entered)

drawn with respect to the adequacy of the craft's stability. The step-by-step method presented will expedite the performance of the analysis, reduce the possibility of errors, and provide complete documentation for design reference. Included is a limited amount of theory explaining each significant step in the analysis. The intent is to provide the analyst with a basic understanding of transverse stability. A complete treatment of the subject may be found in other publications. ↑

UNCLASSIFIED

SECURITY CLASSIFICATION OF THIS PAGE(When Data Entered)

|                                 |   |
|---------------------------------|---|
| ACCESSION for                   |   |
| NTIS                            | White Section <input checked="" type="checkbox"/> |
| BDC                             | Buff Section <input type="checkbox"/>             |
| UNANNOUNCED                     | <input type="checkbox"/>                          |
| JUSTIFICATION.....              |   |
| BY.....                         |   |
| DISTRIBUTION/AVAILABILITY CODES |   |
| Dist.                           | AVAIL. and/or SPECIAL                             |
| A                               |   |

**PROCEDURES MANUAL**  
**DYNAMIC STABILITY ANALYSIS**  
**FOR**  
**U. S. NAVY SMALL CRAFT**

Prepared for

**Combatant Craft Engineering**  
**Naval Ship Engineering Center, Norfolk Division**  
**Norfolk, Virginia**

by

**ASSET Incorporated**  
**8550 Arlington Boulevard**  
**Fairfax, Virginia 22030**

Joseph G. Koelbel, Jr., Naval Architect

Contract No. N00189-74-A-0229

January 1977

Report No. 23095-1

**DDC**  
**RECEIVED**  
 DEC 8 1977  
**RECEIVED**  
**D**

TABLE OF CONTENTS

PART I THEORY

|   | <u>PAGE NO.</u> |
|---|-----------------|
| 1.0 INTRODUCTION  | 2               |
| 1.1 DEFINITION  | 2               |
| 1.2 CONDITION OF CRAFT LOADING                              | 3               |
| 1.3 INTACT AND DAMAGE STABILITY                             | 4               |
| 1.4 OPERATION OF THE CRAFT                                  | 4               |
| 1.5 ENVIRONMENT   | 4               |
| 1.6 CRITICAL COMBINATIONS OF FORCES                         | 5               |
| <br>  |                 |
| 2.0 HYDROSTATIC CHARACTERISTICS OF THE VESSEL               | 5               |
| 2.1 METACENTER & METACENTRIC HEIGHT                         | 7               |
| 2.2 STABILITY AT LARGE ANGLES                               | 9               |
| 2.3 CROSS CURVES OF STABILITY                               | 11              |
| 2.4 RIGHTING ARM CURVE                                      | 11              |
| 2.5 CORRECTION TO RIGHTING ARM CURVES FOR VCG LOCATION (KG) | 14              |
| 2.6 CORRECTION FOR OFF-CENTER CG                            | 14              |
| 2.7 EFFECT OF ADDED WEIGHT ON RIGHTING ARM CURVES           | 20              |
| 2.8 FREE SURFACE EFFECT                                     | 20              |
| <br>  |                 |
| 3.0 UPSETTING FORCES  | 22              |
| 3.1 OFF-CENTER PASSENGERS                                   | 22              |
| 3.2 LIFTING HEAVY WEIGHTS OVER THE SIDE                     | 23              |
| 3.3 WIND HEELING  | 26              |

|                                     | <u>PAGE NO.</u> |
|-------------------------------------|-----------------|
| 3.4 WAVE ACTION                     | 30              |
| 3.5 HEELING ARM PRODUCED BY TURNING | 30              |
| 3.6 TOPSIDE ICING                   | 32              |
| 4.0 DAMAGE STABILITY                | 33              |
| 5.0 STABILITY CRITERIA              | 36              |
| 5.1 INTACT STABILITY CRITERIA       | 36              |
| 5.2 DAMAGE STABILITY CRITERIA       | 41              |

## PART II

### PROCEDURE FOR ANALYSIS

|  |    |
|--|----|
| 6.0 DATA REQUIRED FOR STABILITY ANALYSIS | 45 |
| 6.1 INTACT STABILITY                     | 45 |
| 6.2 DAMAGE STABILITY                     | 46 |
| 7.0 ANALYSIS PROCEDURE                   | 46 |
| 7.1 RIGHTING ARM CURVE                   | 46 |
| 7.2 HEELING ARM CURVES                   | 47 |
| 7.2.1 WIND HEEL                          | 47 |
| 7.2.2 OFF-CENTER WEIGHT                  | 49 |
| 7.2.3 HIGH SPEED TURNING                 | 49 |
| 7.3 DAMAGE STABILITY                     | 50 |
| REFERENCES                               | 50 |
| EXAMPLE CALCULATION                      | 51 |
| APPENDIX - STANDARD FORMS                |    |

## LIST OF FIGURES

| Figure No. | Title   | Page No. |
|------------|---|----------|
| 1          | Curves of Form for 100' CPIC-X                      | 6        |
| 2          | Positive, Negative, and Neutral Stability           | 8        |
| 3          | Stability Definitions at Large Angles               | 10       |
| 4          | Cross Curves of Stability                           | 12       |
| 5          | Righting Arm Curve                                  | 13       |
| 6          | Correction for VCG Location                         | 15       |
| 7          | Righting Arm Curve and VCG Correction               | 16       |
| 8          | Craft With Off-Center Weight                        | 17       |
| 9          | Correction for Off-Center CG                        | 18       |
| 10         | Righting Arm Curve and Off-Center Correction        | 19       |
| 11         | Free Surface Effects                                | 21       |
| 12         | Hoisting Weights Alongside                          | 24       |
| 13         | Partial Restraint of Swinging Load                  | 25       |
| 14         | Wind Velocity Profile                               | 27       |
| 15         | Determination of Projected Sail Area                | 28       |
| 16         | Projected Sail Area at Several Heel Angles          | 29       |
| 17         | Wind Heeling Arm Curve                              | 31       |
| 18         | Sample Damage Stability Output                      | 34       |
| 19         | Damaged Center of Buoyancy                          | 35       |
| 20         | Criteria for Beam Winds Combined With Rolling       | 38       |
| 21         | Criteria for Off-Center Weights or High Speed Turns | 39       |
| 22         | Criteria for Damage Stability                       | 42       |
| 23         | Required Stability in Damaged Condition             | 43       |

LIST OF FORMS

- FORM NO. 1. WEIGHT AND C.G. CALCULATION WORK SHEET
- FORM NO. 2. RIGHTING ARM CALCULATION
- FORM NO. 3. WIND HEEL CALCULATIONS
- FORM NO. 4. STABILITY CURVES
- FORM NO. 5. CALCULATION FOR OFF-CENTER LOAD
- FORM NO. 6. CALCULATION FOR HIGH SPEED TURN

ESTIMATE OF WEIGHT FOR BOATS

WORK SHEET

BOAT IN LIGHT CONDITION

BOAT IN HOISTING CONDITION

BOAT IN TRIAL CONDITION

BOAT IN FULL LOAD CONDITION

PART I

THEORY

## PART I - THEORY

### 1.0 INTRODUCTION

This manual presents the procedures and background information necessary to perform a transverse dynamic stability analysis of U.S. Navy small craft.

The manual is intended for use by new engineers and technicians who might not be familiar with the stability aspects of Naval Architecture. The procedure has been ordered and sequenced (and work sheets provided) so that the analysis can be performed, comparison made with stability criteria, and conclusions drawn with respect to the adequacy of the craft's stability. The step-by-step method presented herein will expedite the performance of the analysis, reduce the possibility of errors, and provide complete documentation for design reference.

Included is a limited amount of theory explaining each significant step in the analysis. The intent is to provide the analyst with a basic understanding of transverse stability. A complete treatment of the subject may be found in "Principles of Naval Architecture" published by the Society of Naval Architects and Marine Engineers and in other standard works.

### 1.1 DEFINITION

When a craft is tilted by some disturbing influence it tends to return to its upright position or else to overturn. This tendency to rotate one way or another is referred to as its stability. The measure of this stability is

a moment tending to restore or overturn the ship. The moment is made up of two forces: buoyancy and gravity. When the ship is at rest these forces both act in the same vertical line. When the ship is rotated from the at rest position the shape of the buoyant volume changes thereby shifting the center of buoyancy away from its initial line of action through the center of gravity. This displacement of the two equal and opposite forces produces the above mentioned moment.

The disturbances to stability are wave action, wind, high speed turns, recoil from gun fire, rocket blasts, off-center weights and others. An analysis of transverse stability is made to determine the effectiveness of the ship in countering some or all of these disturbances.

The buoyancy characteristics of a particular craft are set forth in the "Curves of Form" and "Cross Curves of Stability". Examples of these are shown in Figures 1 and 4.

## 1.2 CONDITION OF CRAFT LOADING

Transverse stability varies with the condition of the craft in that the relationship between the two forces, buoyancy and gravity, are varied with change in loading, i.e., the weight of the craft and its distribution. Typical load conditions which are checked against stability criteria are:

- (a) Full load condition
- (b) Full load plus overload
- (c) Minimum operating
- (d) Minimum operating plus overload
- (e) Light

These load conditions are influenced by craft weight, ammunition, stores, potable water, fuel, cargo, complement, and other items of variable load determined by the requirements of the craft's mission and its condition at departure and return.

NAVSHIPS FORM 4616 A-4 (11-57) "Estimate of Weight for Ships" or NAVSHIPS FORM 4616-2 (REV 11-57) "Estimate of Weight for Boats" (several pages) provides the load conditions with a weight breakdown and other information required for this stability analysis (See Appendix - sample copy of a weight/condition estimate).

### 1.3 INTACT AND DAMAGE STABILITY

The underwater body may be intact or it may be damaged so that the sea is no longer excluded. Analysis of both conditions must be performed. The procedure is basically the same. Damage results in flooding, however, which causes a change in buoyancy, trim and other factors which must be allowed for in the stability analysis. The changes in buoyancy characteristics of the flooded compartments are set forth in "Damage Stability Calculations". See Figure 18 for sample computer printout of the buoyancy data for a damaged condition.

### 1.4 OPERATION OF THE CRAFT

Forces which influence the stability of the craft during operation are as follows:

- (a) High Speed Turn
- (b) Gun fire, rocket blast
- (c) Shifting of weights on board
- (d) Addition of off-center weights
- (e) Collision or enemy hit impact

### 1.5 ENVIRONMENT

Operating environment influences the stability of the craft and the upsetting forces are from:

- (a) Wind - primarily beam

(b) Icing - primarily top side

(c) Wave action

The effect of these items and those in section 1.4 above are included in the stability analysis.

#### 1.6 CRITICAL COMBINATIONS OF FORCES

The transverse stability is examined for a combination of forces acting concurrently, usually beam wind and wave action, but frequently including icing or other factors set forth above. One of the objectives of the analysis is to determine the limitations of the craft or, sometimes, the operational techniques which can be used to minimize the effects of extreme environment.

#### 2.0 HYDROSTATIC CHARACTERISTICS OF THE CRAFT

The hydrostatic characteristics of the craft in the upright position, i.e., zero heel and zero trim, are given in the "Curves of Form". These curves represent various geometric properties of the hull form. They are calculated for the portion of the hull below each of several waterlines and then plotted against draft as shown in Figure 1. The more important curves from the standpoint of stability are those for:

- (a) Displacement, which gives the draft at LCF at which the craft will float in a given loading condition.
- (b) LCB (longitudinal center of buoyancy) which, when compared with the LCG, indicates whether or not the craft will float at level trim. The difference between LCB and LCG is the trimming lever.
- (c) MT1 (moment to trim one inch) by which the amount of trim is calculated.
- (d) KM (the height of the metacenter above the baseline), from which KG is subtracted to get GM for a specific condition of loading.

DAP = 1 INCH = 10 LT.  
 KMT = 1.00 FT.  
 BMT = 1.00 FT.  
 VCB = 1.00 FT. ABOVE B.  
 LCB = 1.00 FT. FROM MIDSHIPS  
 LCF = 1.00 FT. FROM MIDSHIPS

VOLUME = 1 INCH = 400 CUBIC FT.  
 MTI = 1 TON-FT.  
 W.P. AREA = 1 = 100 SQ. FT.  
 CHANGE IN DISPL. FOR 1 FT. OF TRIM = 1 INCH = 1 L.T.

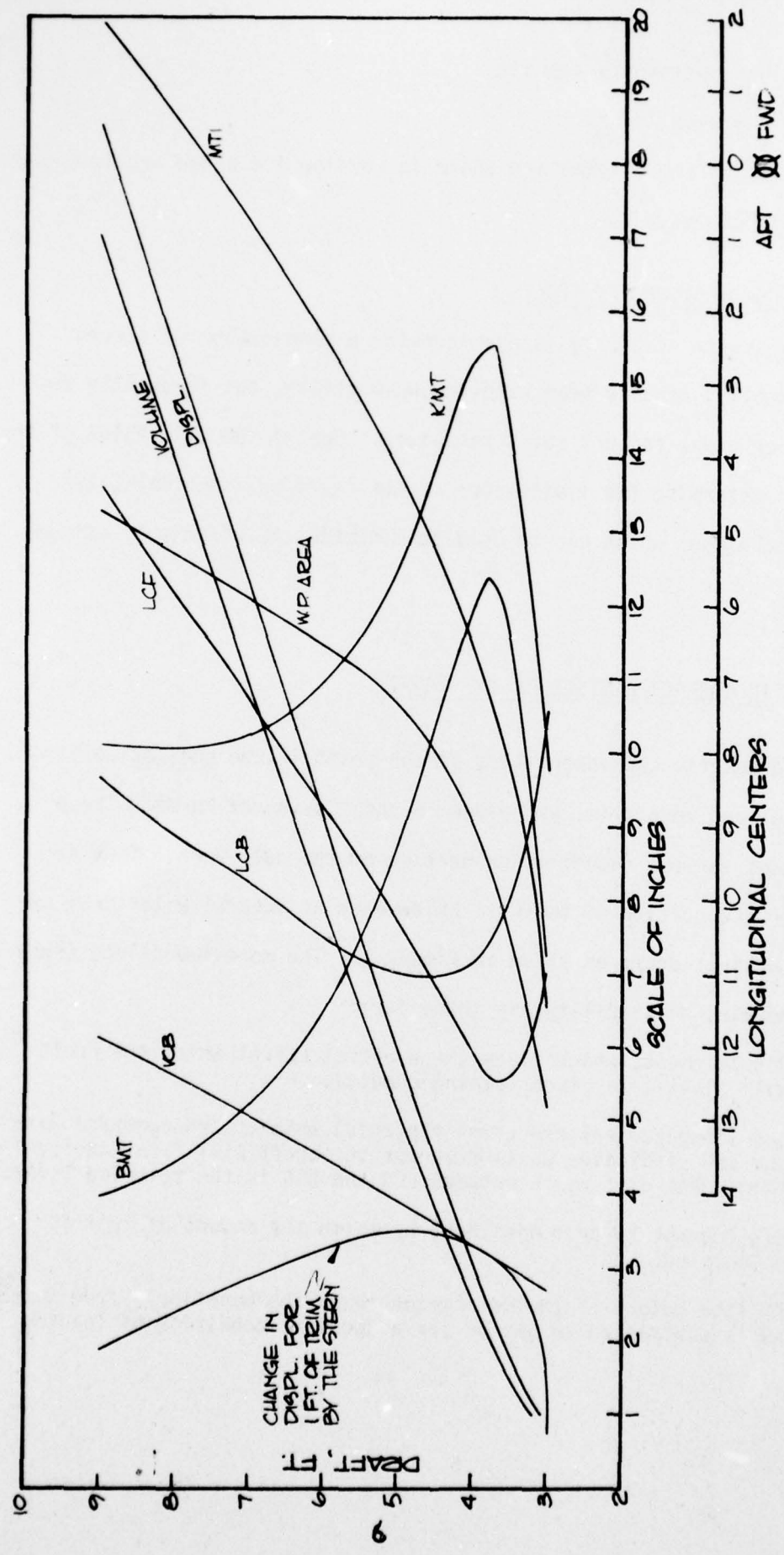

CURVES ARE BASED ON 0 TRIM. DO NOT SCALE DRAWING

FIGURE 1  
CURVES OF FORM FOR 100 CPIC-X

In general, these calculations are done on the summary weight sheets of the Navships forms mentioned in paragraph 1.2 above.

The hydrostatic characteristics of the craft when inclined to small and large angles are discussed in sections 2.1 and 2.2 following.

## 2.1 METACENTER AND METACENTRIC HEIGHT

As a craft is rotated, at constant displacement, away from its upright position of equilibrium the centroid of the underwater volume moves off the centerline and upward describing a curve. The center of curvature of this curve is the metacenter. Looked at another way, the metacenter is the intersection of verticals through the center of buoyancy when the craft is rotated, at constant displacement, through an infinitesimally small angle. There is a metacenter for any position of a body which pierces the surface of the water, whether wholly or partially supported by the buoyancy of the immersed volume. Physically the metacenter is the highest point to which the center of gravity may be raised and still retain positive stability, as described in the next paragraph. In general, the metacenter is a useful measure of stability at small angles only. See Figure 2, as discussed below.

If the center of gravity,  $G$ , is at the metacenter,  $M$ , the craft is neutrally stable. That is, when given a small rotation it will tend to remain in its new position. If  $G$  is above  $M$  (negative  $GM$ ) the craft is in unstable equilibrium and, if given a small rotation, will tend to rotate further. Conversely, when  $G$  is below  $M$  (positive  $GM$ ), the craft is in stable equilibrium and, when given a small rotation will tend to return to the original position. The greater the  $GM$  (assumed positive) the stronger the tendency to remain upright. The distance  $GM$  is known as the metacentric height and is a direct measure of initial stability, as just described. However,  $GM$  itself does not

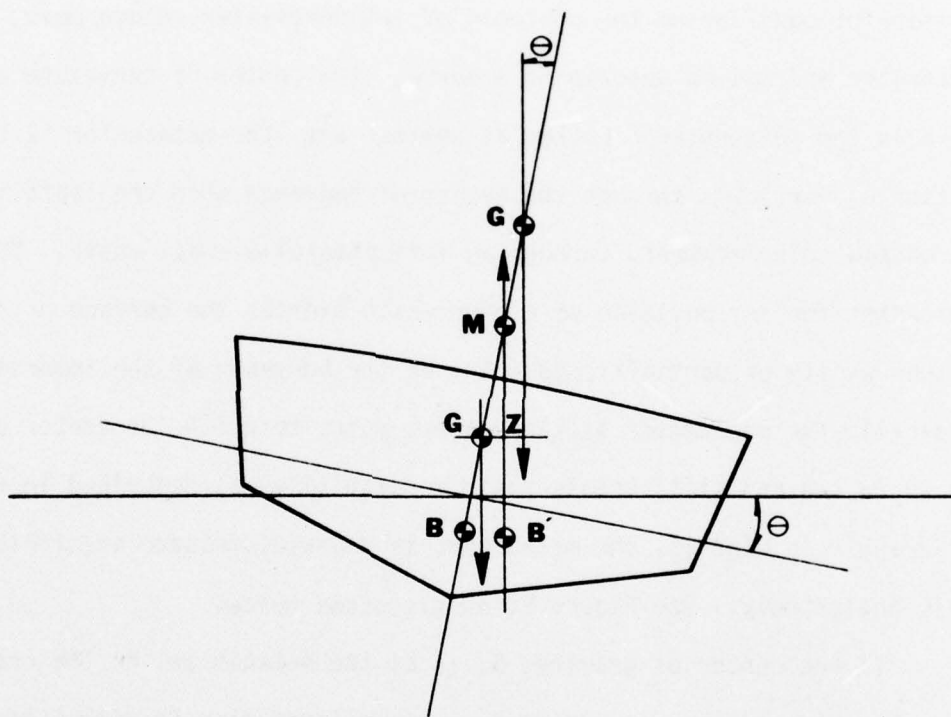

**FIGURE 2**  
**POSITIVE, NEGATIVE, AND NEUTRAL STABILITY**

right the craft, but the couple formed by the weight and buoyancy of the craft when they are displaced from their co-linear positions.

These features are illustrated in Figure 2 in which the heel angle,  $\theta$ , is exaggerated for clarity. The distance between the lines of action of buoyancy and gravity is shown in the figure as GZ, the righting arm. The righting moment is equal to the righting arm multiplied by the displacement,  $\Delta$ , or

$$RM = \Delta GZ$$

For small heel angles, up to about  $7^\circ$ , the metacenter is considered to remain fixed on the centerline of the craft. Thus for small angles the righting arm is

$$GZ = GM \sin \theta$$

and the righting moment is therefore

$$RM = \Delta GM \sin \theta$$

The stability is directly proportional to GM.

The initial GM is related to the period of roll of the craft by the equation

$$T = \frac{kB}{\sqrt{GM}} \quad \text{where } T = \text{natural roll period, sec.}$$

B = maximum beam of the craft, ft

k = constant

The constant, k, accounts for the transverse radius of gyration (a function of beam) and the damping effects. A value of 0.44 is used unless another value has been determined by model or, preferably, full scale tests.

## 2.2 STABILITY AT LARGE ANGLES

At angles of inclination beyond 8 to 10 degrees the metacenter is no longer significant since the righting arm (and moment) is no longer proportional to the initial GM. The stability of the craft is still, however, dependent on the relationship of the center of buoyancy to the center of



gravity. Referring to Figure 3:

Heel angle =  $\theta$

Weight of craft,  $W$ , = buoyant force,  $\Delta$ , = displacement.

$GZ$  = righting arm

Restoring Couple =  $\Delta GZ$  = Righting Moment,  $RM$ .

Calculations of righting arm for pole height = 0 ( $G$  assumed at baseline) at several displacements and heel angles are done on a computer and printed out for use in the stability analysis.

### 2.3 CROSS CURVES OF STABILITY

Righting arms for several displacements at each angle of heel are plotted as shown in Figure 4. They are based on an assumed vertical location of the center of gravity of the craft, considered to be at the base line (pole height equals zero). Righting arms can be corrected for any vertical location of the center of gravity. They are based on the assumption of fixed trim of the craft for all heel angles. This assumption is considered to be valid for trims less than 1% of the waterline length. If greater trim will occur the righting arms must be calculated for one or more additional trim conditions.

### 2.4 RIGHTING ARM CURVE

Figure 5 shows a curve of  $GZ$  plotted against heel angle. This curve must be drawn for a specific loading condition, that is, a specific displacement and vertical center of gravity. The righting arms at a specific displacement are read off the cross curves at each heel angle and corrected for the vertical shift in C.G. as described in 2.5 below. They are then plotted against heel angle as in Figure 5.

The curve shows the following important characteristics of transverse stability and the craft's ability to resist capsizing in a given condition.

ASSUMED C.G. AT - BASELINE

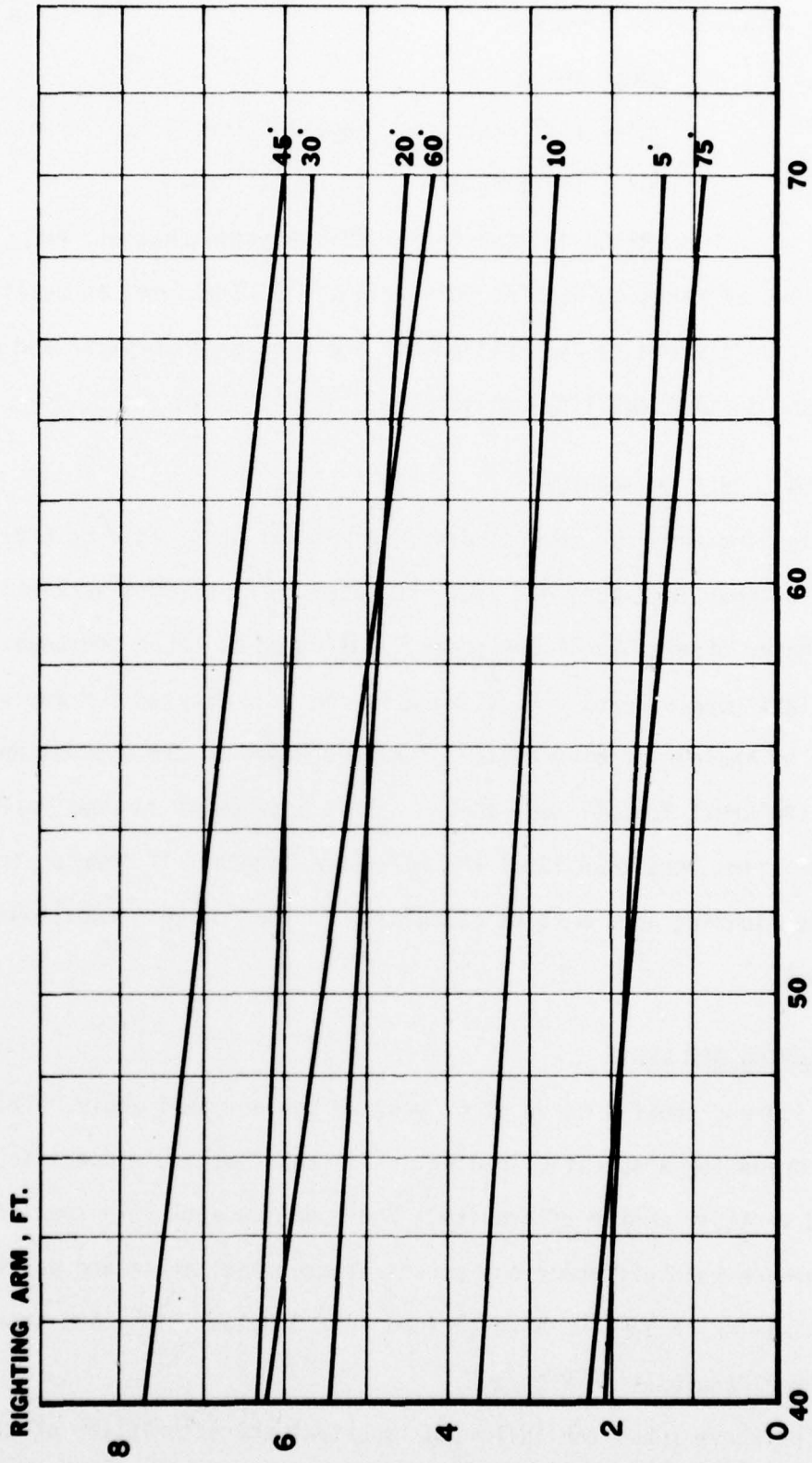

DISPLACEMENT, L.T.  
FIGURE 4  
CROSS CURVES OF STABILITY (INTACT)

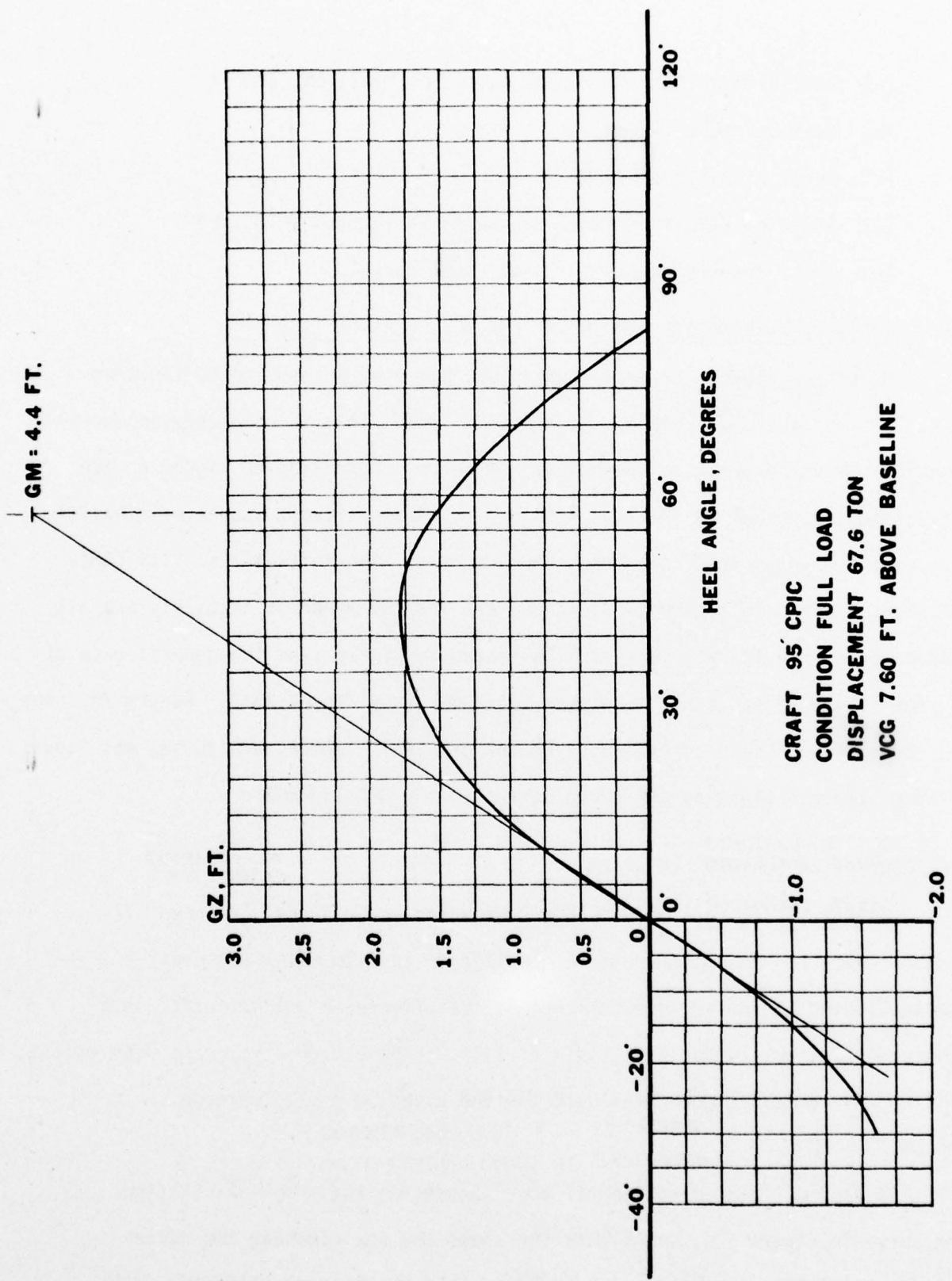

CRAFT 95' CPIC  
 CONDITION FULL LOAD  
 DISPLACEMENT 67.6 TON  
 VCG 7.60 FT. ABOVE BASELINE

FIGURE 5  
 RIGHTING ARM CURVE

- (a) Initial stability for small angles of heel, GM, 4.4 ft
- (b) Maximum righting arm, GZ, 1.76 ft
- (c) Angle of maximum GZ, 42°
- (d) Range of stability (angle at which GZ returns to 0), 83°
- (e) Total dynamic stability (area under curve)

## 2.5 CORRECTION TO RIGHTING ARM CURVES FOR VCG LOCATION (KG)

As stated above, the cross curves are based on an assumed CG location on the centerplane and, usually, at the base line. This is obviously an unreal location but it serves as a convenient reference. Referring to Figure 6, the correction for actual CG location =  $KG \sin \theta$ . A significant aspect of stability will become obvious from this correction process. The initial stability (GM), the righting arms (GZ) throughout the range, and the range of stability are all reduced by a rise in CG. This is illustrated in Figure 7 as the general case of CG rise from G to G' rather than the particular case from K to G. Figure 7a shows the curve of  $GG' \sin \theta$  superimposed on the original righting arm curve, and Figure 7b shows the new righting arm curve corrected for  $GG' \sin \theta$ .

## 2.6 CORRECTION FOR OFF-CENTER CG

Weight shifts such as passengers crowding to one side, or cargo off-center reduce the amount of reserve stability. In calm water the craft remains listed at the angle determined by the off-center weight shift; in a seaway it will roll about this angle of list. Figure 8 shows a craft with weight shifted off-center. Figure 9 illustrates the righting arm correction =  $CG' \cos \theta$ .

A plot of this correction is superimposed on the original righting arm curve in Figure 10a, and Figure 10b shows the new righting arm curve corrected for  $CG' \cos \theta$ . It will be noted that the lateral shift of weight increases the stability for rotations away from the initial list.

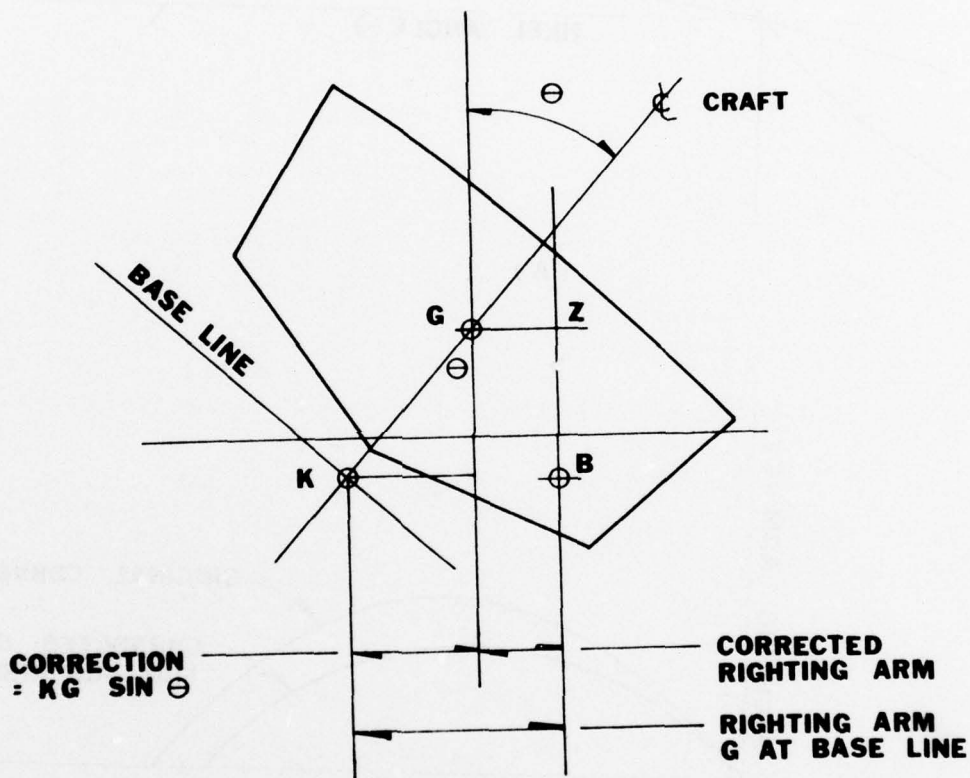

**FIGURE 6**  
**CORRECTION FOR VCG LOCATION**  
**(INITIALLY ASSUMED AT BASE LINE)**

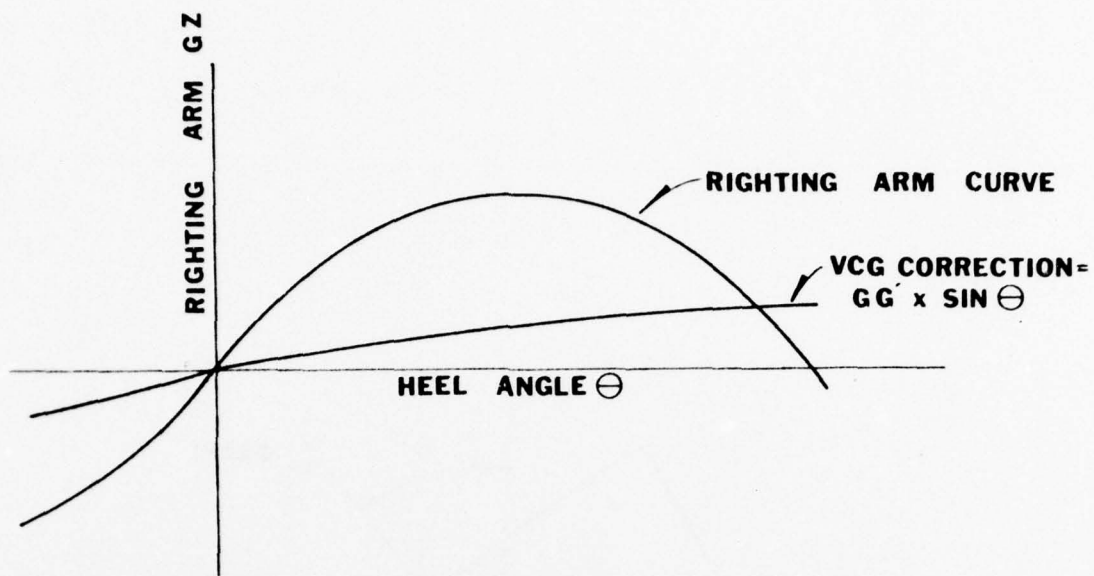

( A )

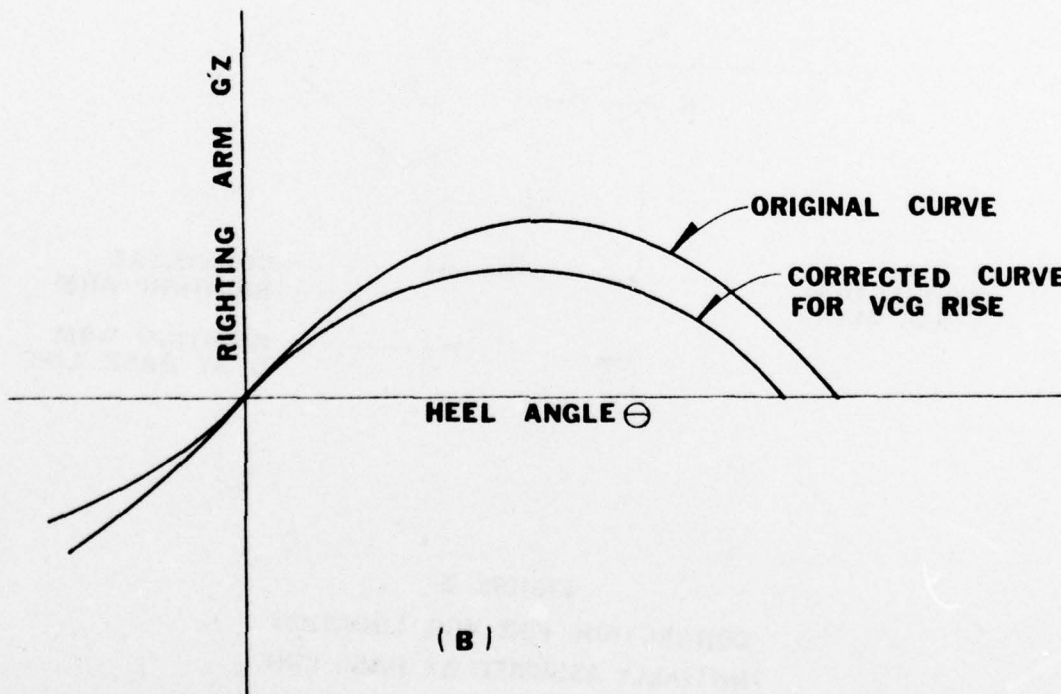

( B )

**FIGURE 7**  
**RIGHTING ARM CURVE & VCG CORRECTION**

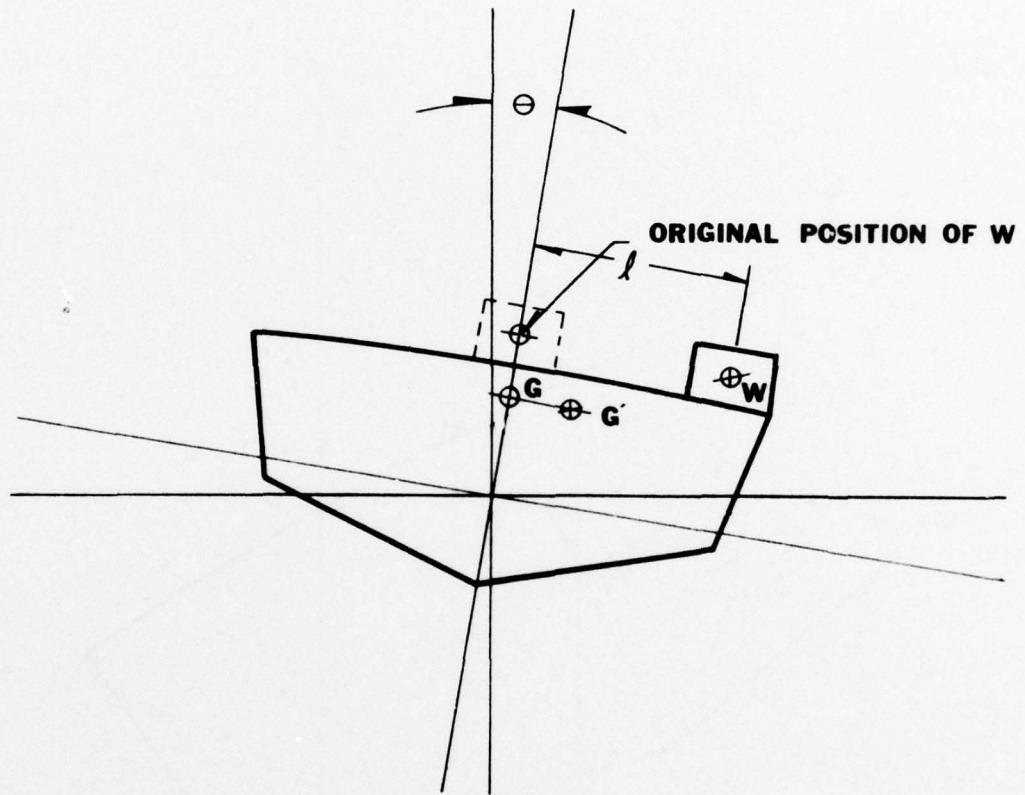

**FIGURE 8**  
**CRAFT WITH OFF-CENTER WEIGHT**

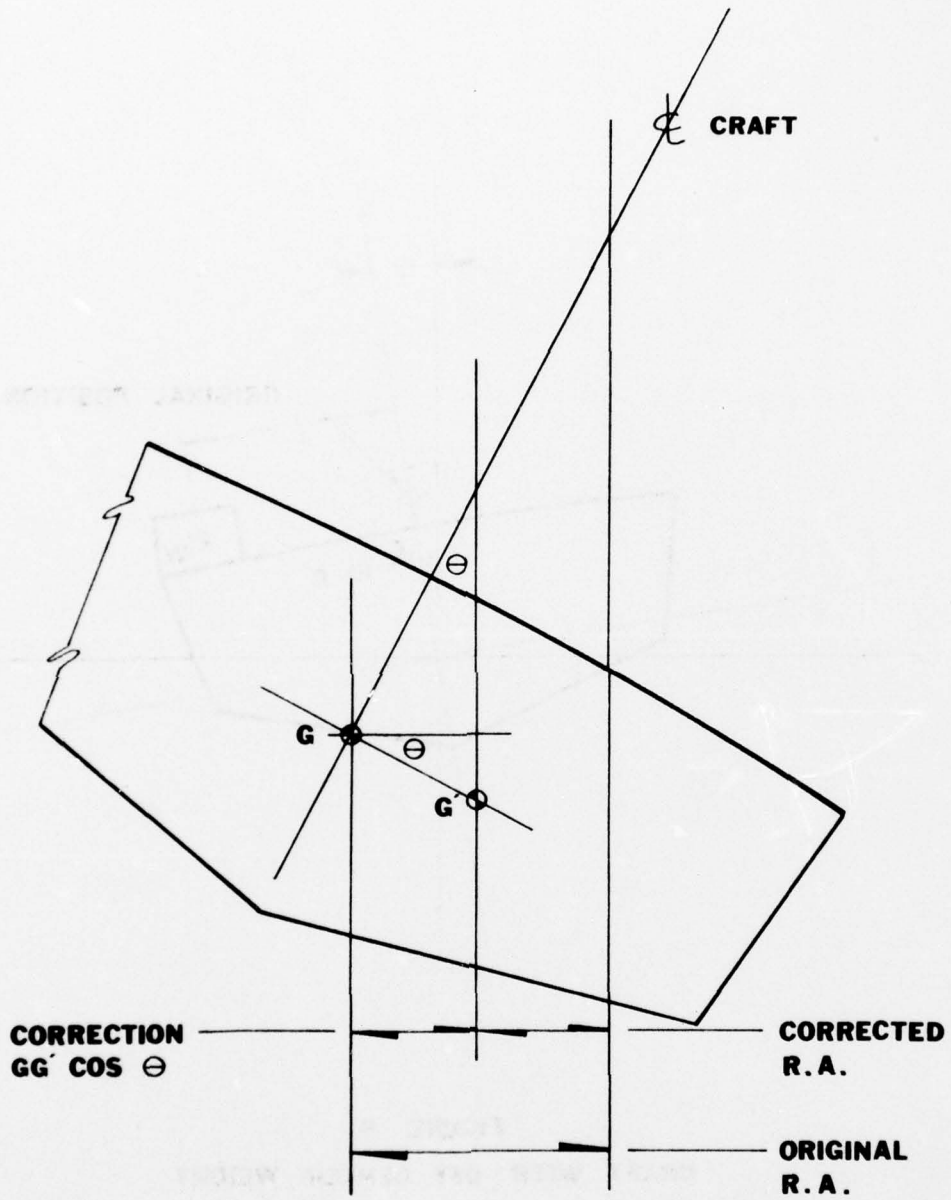

**FIGURE 9**  
**CORRECTION FOR OFF-CENTER CG**

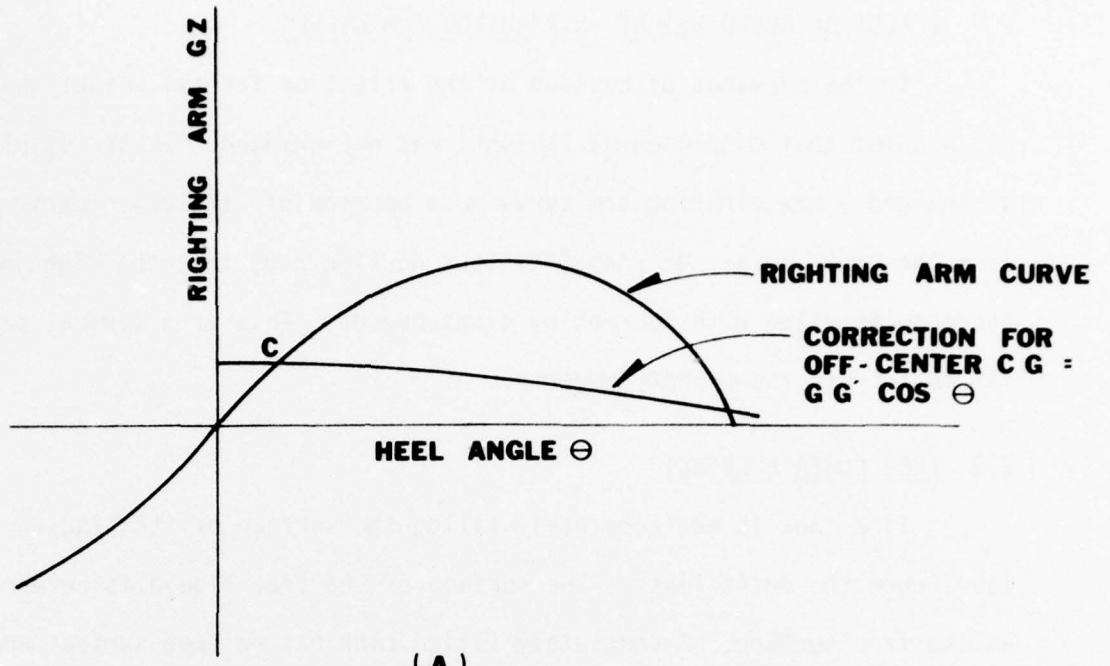

(A)

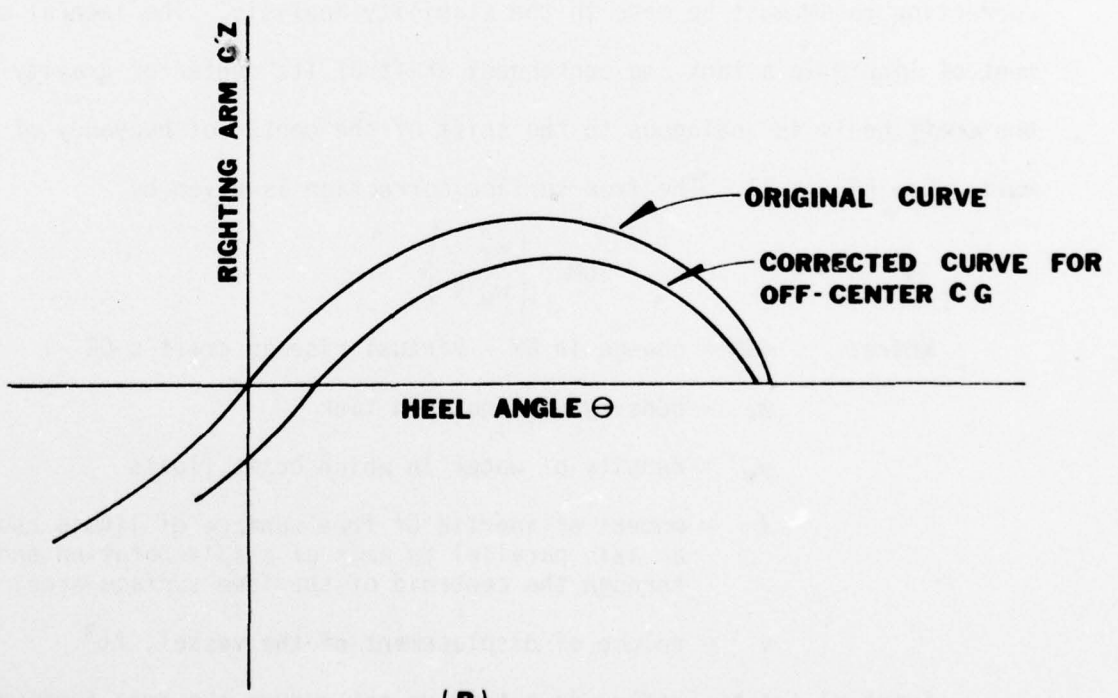

(B)

FIGURE 10  
 RIGHTING ARM CURVE & OFF-CENTER CORRECTION

## 2.7 EFFECT OF ADDED WEIGHT ON RIGHTING ARM CURVES

In the previous discussion of the effect of lateral weight shift it was assumed that displacement (weight) was not changed. If the displacement is changed a new righting arm curve must be read off the cross-curves. Note from the cross curves of stability (see Section 2.3) that the righting arms decrease in value with increasing displacement. This is a typical pattern for most craft though not universal.

## 2.8 FREE SURFACE EFFECT

If a tank is not completely filled the surface of its liquid remains level when the craft lists. The surface of the free liquid is referred to as the free surface. A completely filled tank has no free surface and can be treated as a solid. If the tank is not filled completely a free surface correction to GM must be made in the stability analysis. The lateral movement of liquid in a tank and consequent shift of its center of gravity when the craft heels is analogous to the shift of the center of buoyancy of the hull. See Figure 11. The free surface correction is given by

$$\delta GM = \left( \frac{w_l i}{w_w \nabla} \right)$$

Where:  $\delta GM$  = change in GM = virtual rise in craft's CG

$w_l$  = density of liquid in tank

$w_w$  = density of water in which craft floats

$i$  = moment of inertia of free surface of liquid about an axis parallel to axis of ship's rotation and through the centroid of the free surface area, ft<sup>4</sup>.

$\nabla$  = volume of displacement of the vessel, ft<sup>3</sup>.

Swash plates or baffles in a tank do not reduce the free surface unless they are completely tight thus creating separate tanks. If two (or more) tanks are cross connected, even by a small leveling line, they act as a single tank for free surface effect and the moment of inertia of the total surface

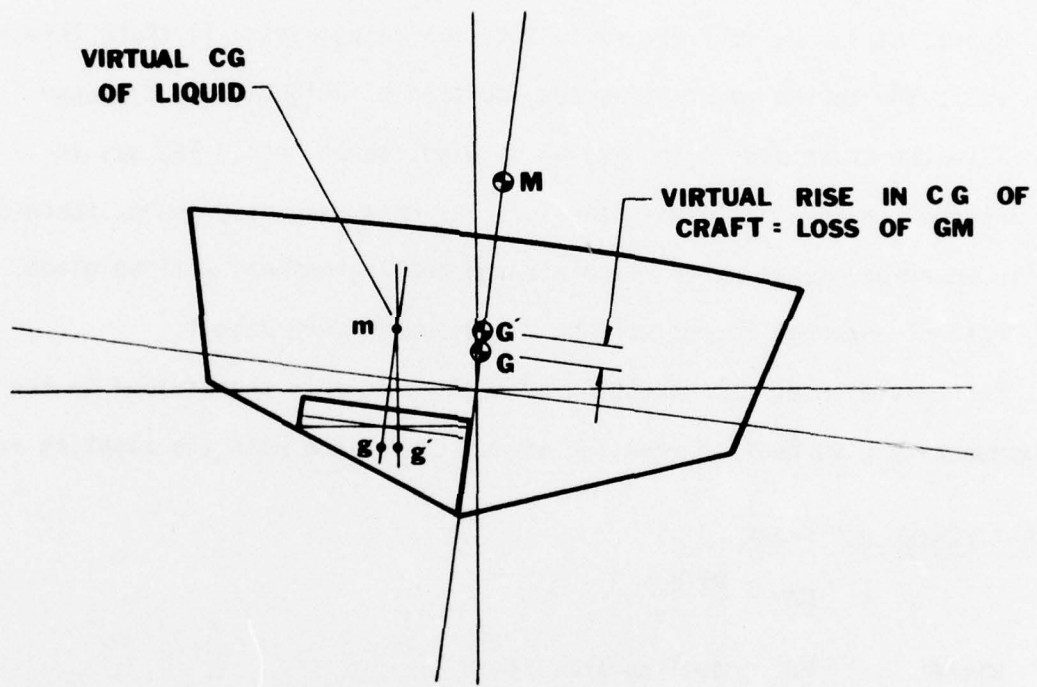

**FIGURE 11**  
**FREE SURFACE EFFECTS**

area about a longitudinal axis through the combined centroid of surface area must be used for  $\bar{c}$  in the above equation.

If there are large, deep tanks, it is sometimes necessary to correct the vertical and transverse CG of the craft at several (large) angles of heel to obtain a righting arm correction for movement of loose liquid in the tank.

### 3.0 UPSETTING FORCES

Upsetting forces fall generally into two categories: 1) those internal to the craft due to the movement and/or addition of weights, and 2) those external to the craft due to the action of wind, waves, etc. The way in which internal changes influence stability has been discussed above; therefore, only the equation necessary to calculate the heeling moments will be given. The effects of external forces will be discussed in more detail.

For convenience, the upsetting or heeling moments are divided by the displacement to give heeling arms for direct comparison with the righting arms.

### 3.1 OFF-CENTER PASSENGERS

$$HA = \frac{Wa \cos \theta}{\Delta}$$

Where:

HA = heeling arm, ft

W = weight of passengers, lb

a = distance from  $\bar{c}$  craft to center of gravity of passengers, ft

$\Delta$  = displacement, lb

$\theta$  = heel angle

Assume:

- each passenger occupies 2 sq. ft;
- each passenger weighs 165 lbs, or as specified for the particular case;

- all passengers have moved to one side as far as possible. See discussion of Reference 1 by James B. Robertson, Jr.

### 3.2 LIFTING HEAVY WEIGHTS OVER THE SIDE

If the weight to be lifted has not been included in the craft's weight calculation, a righting arm curve must be plotted for a displacement which includes the lifted weight, assumed to be added at the VCG (pole height) for which the cross curves are plotted.

If the weight lifted is free to swing on the hoisting cable, the weight will always act downward through the point of attachment on the boom. This has the same effect as locating the entire weight at the point of attachment. Therefore the vertical center of gravity location (VCG) must be corrected for the addition of the weight at that height. For this purpose the weight is initially assumed to be on the centerline. Then a further correction is made for the lateral shift of the weight out to the actual point of attachment on the boom. See Figure 12. If the load is restrained against swinging, its effective vertical location is as shown in Figure 13.

The steps are (referring to Figures 12 and 13):

- Add weight at axis for cross curves.
- Move weight,  $W$ , up to height,  $h$ , above the base line. The new VCG is

$$KG' = (\Delta KG + W h) / (\Delta + W)$$

and the correction to the righting arm is

$$KG' \sin \theta.$$

- Move the weight a distance,  $\ell$ , off center. The shift of the vessel's center of gravity is

$$G'G'' = W\ell / (\Delta + W)$$

and the correction to the righting arm is

$$G'G'' \cos \theta.$$

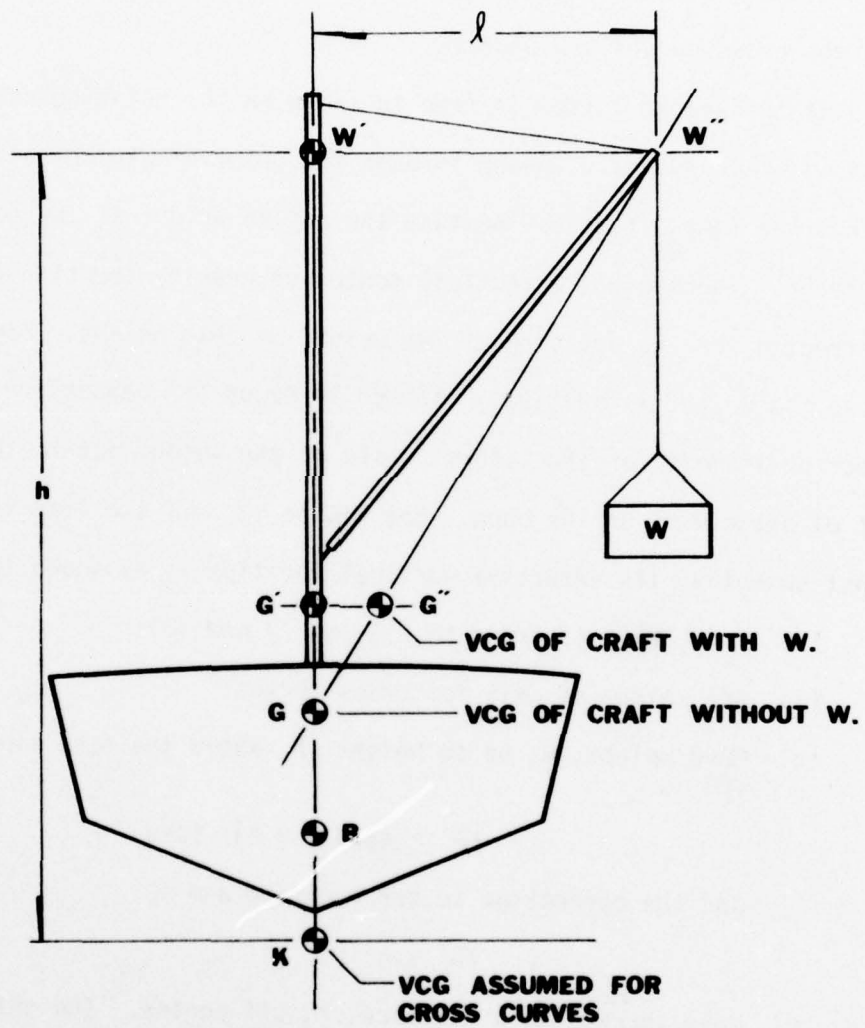

**FIGURE 12**  
**HOISTING WEIGHTS ALONGSIDE**

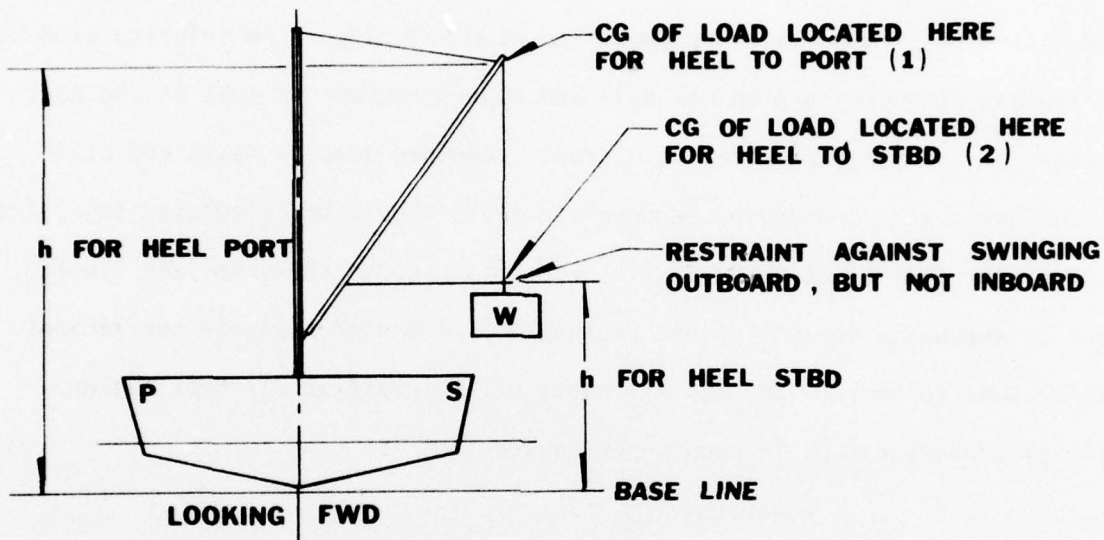

**THIS SITUATION CAUSES A DISCONTINUITY IN THE RIGHTING ARM CURVE**

- (1) THIS CONDITION IS OF INTEREST ONLY IN THE CASE OF ROLLING IN WAVES, BECAUSE HEEL TO PORT CANNOT OCCUR IN CALM WATER
- (2) THIS CONDITION IS OF PRIMARY INTEREST

**FIGURE 13  
PARTIAL RESTRAINT OF SWINGING LOAD**

### 3.3 WIND HEELING

Wind velocity increases with height above the water because of ground effect. It is conventional to measure velocity at a height of 10 meters (33 ft approx). Figure 14 shows the decrease in velocity below this level for a 100 kt wind. The velocities also represent percentages of the velocity at 10 meters to be used with any specified wind velocity. The velocity used to calculate wind pressure on the hull and superstructure is that at the half height of the projected profile of these combined areas. Masts and other structures extending above the superstructure should be calculated separately using the velocity at their level. For this purpose the areas are blocked out in approximately equivalent rectangles. The wind pressure coefficient is assumed to be the same for all parts of the craft at all heel angles. The wind pressure,  $p$ , in pounds per square foot is

$$p = 0.004 V_k^2$$

Where  $V_k$  = wind velocity in knots at centroid of the area in question

0.004 = a constant to account for both the drag coefficient and the units.

The projected area on which the wind is assumed to act is taken from an end view of the blocked out rectangular profile planes described above. Figures 15 and 16 illustrate this. The moment of area about the half draft point is calculated at each of several heel angles and multiplied by the wind pressure,  $p$ , as calculated above, to give heeling moments. These are divided by the displacement (in pounds, to be consistent with the wind pressure), to produce heeling arms:

$$HA = p A h / \Delta$$

Where: HA = heeling arm, ft

A = the total projected area, ft<sup>2</sup>

h = the height of the centroid of the area above the half draft point, ft, as shown in Figure 16 for 90° heel.

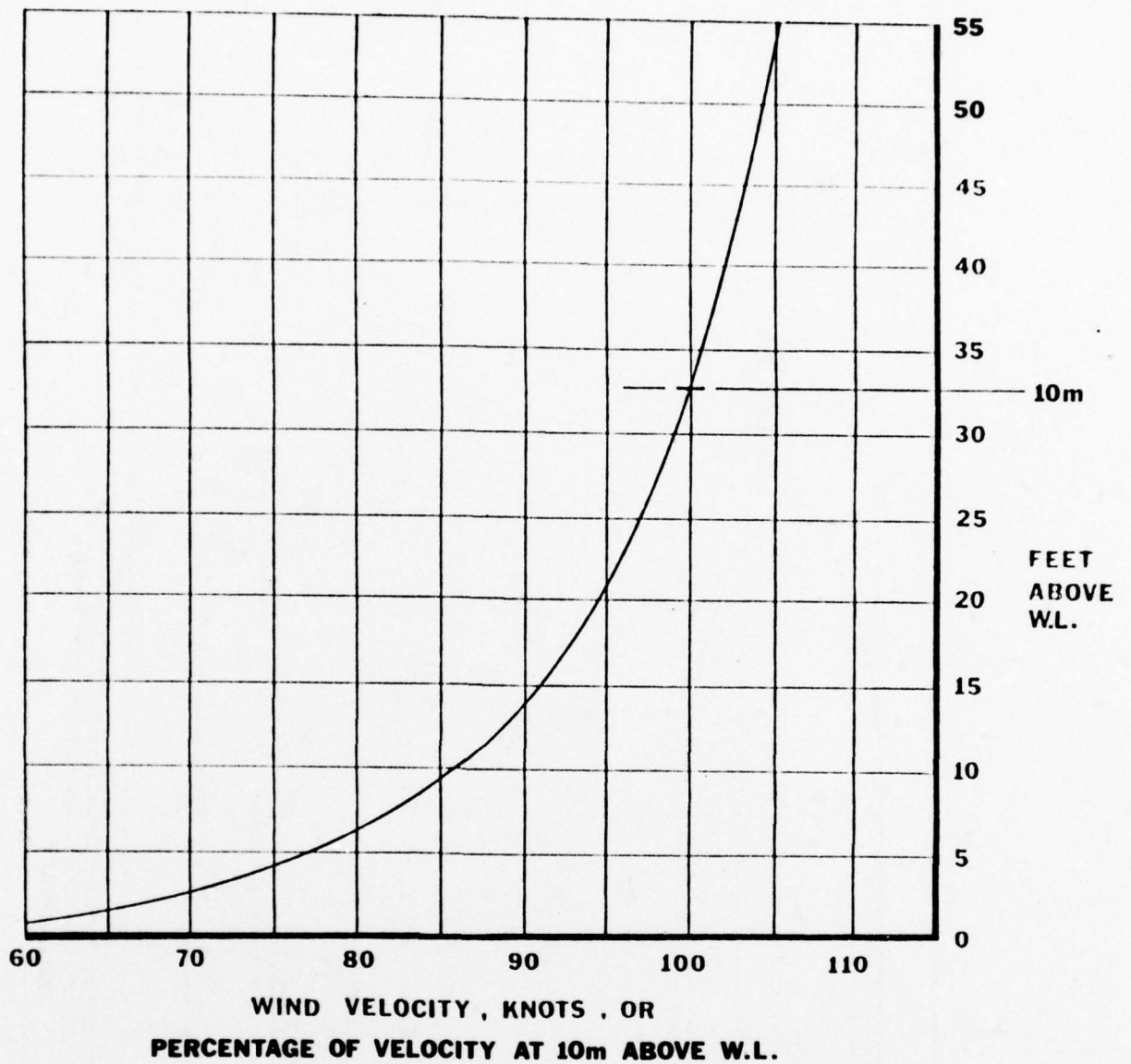

**EXAMPLE :**

**CENTROID OF SAIL AREA      10' ABOVE W.L.**  
**DESIGN WIND VELOCITY        60 KNOTS**

$$\text{VELOCITY AT 10' } = \frac{85}{100} \times 60 = 51 \text{ KNOTS}$$

**FIGURE 14**  
**WIND VELOCITY PROFILE**

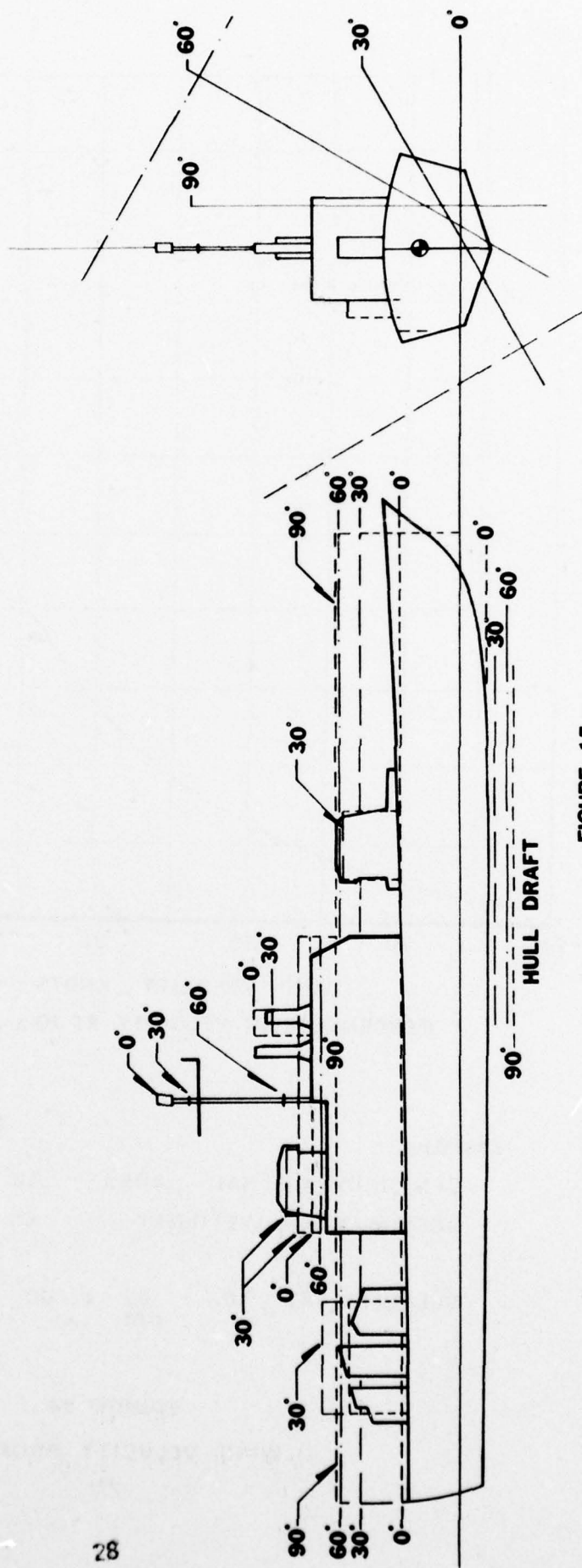
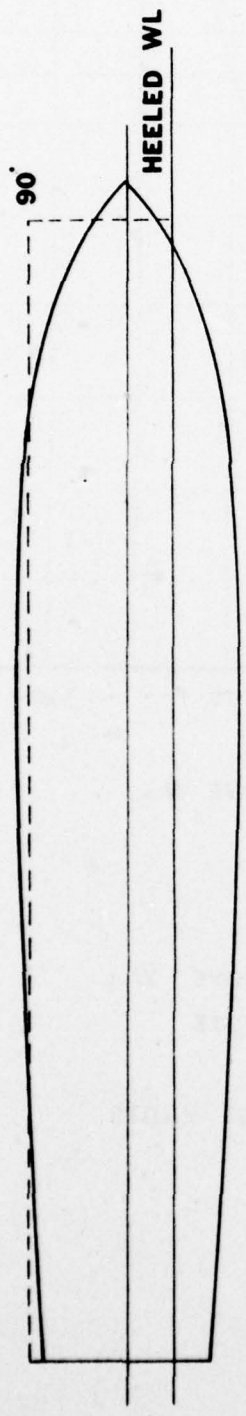

FIGURE 15  
DETERMINATION OF PROJECTED SAIL AREA

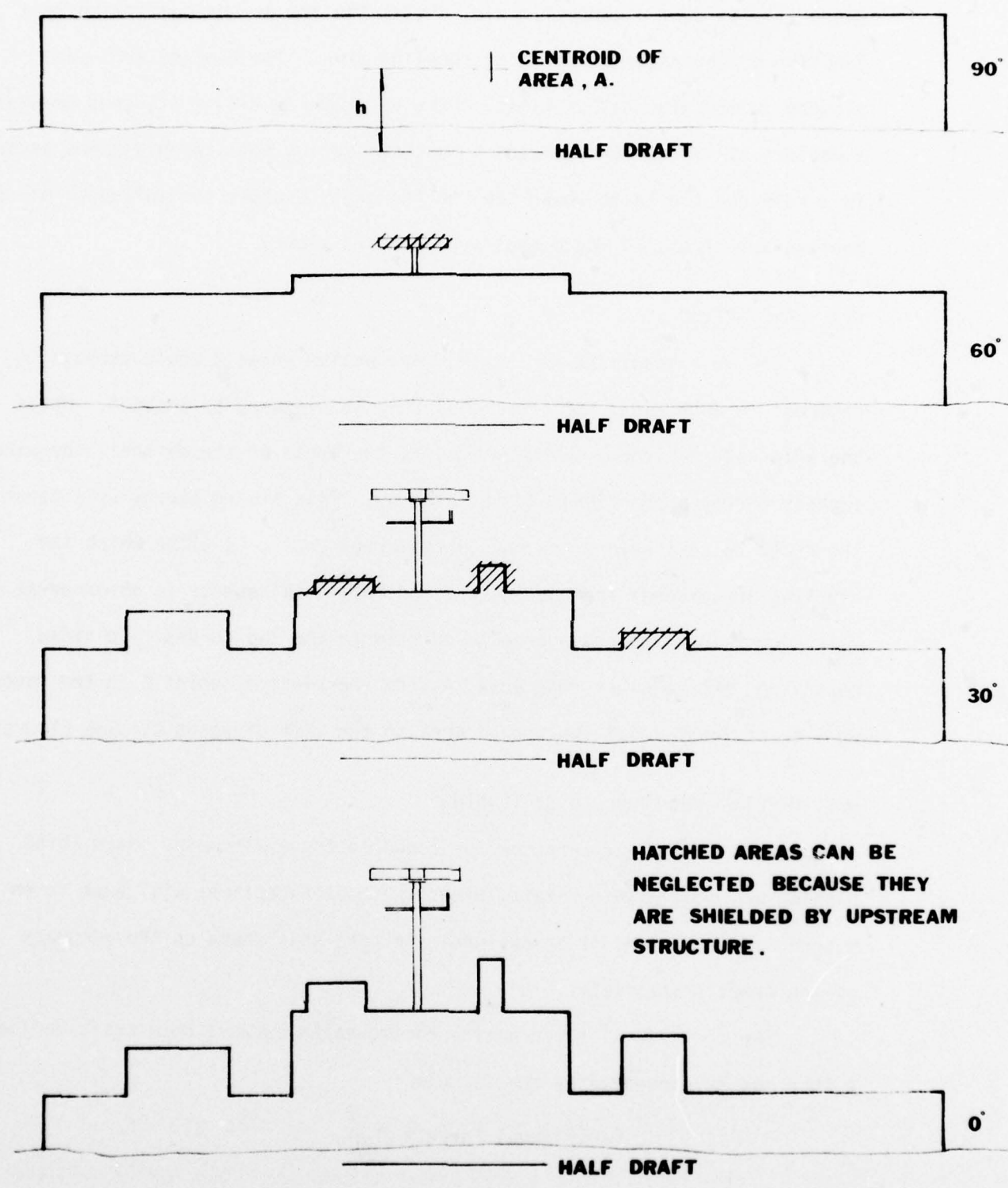

FIGURE 16  
 PROJECTED SAIL AREA AT SEVERAL HEEL ANGLES

Since this is done at specific heel angles the arm is not multiplied by a function of the angle as for other heeling arms. The heeling arms are plotted on the statical stability curve as shown in Figure 17, thus providing a measure of the energy imparted to a craft during roll to an assumed angle. In a calm sea the craft would heel to the angle C under the influence of the heeling arm shown, if the moment were applied slowly.

### 3.4 WAVE ACTION

If, in a specified sea state, wave action rolls a craft through  $\theta_r$  degrees\* to each side, the craft will roll to windward to angle A. While the ship returns from a windward roll to the angle of steady heel, the wind imparts energy proportional to the area  $A_2$ . This stored energy will cause the craft to roll beyond the equilibrium heel angle, C, after which the righting arm exceeds the heeling arm and rotational energy is absorbed at a rate proportional to the accrued area between the two curves. To avoid capsizing, the total of this area,  $A_1$ , to the right of point C in the figure must be at least equal the shaded area to the left of point C. See Figure 17.

### 3.5 HEELING ARM PRODUCED BY TURNING

This is usually a factor for round bottom craft only. Hard chine planing and semi-planing craft, almost without exception, will bank in on a turn. Nevertheless it is advisable to make this check on the adequacy of the craft's stability.

The centrifugal force acting horizontally outward on a craft during a turn may be expressed by the formula:

$$\text{Centrifugal Force} = \frac{\Delta v^2}{gR}$$

\*Described in Section 5.1.1.

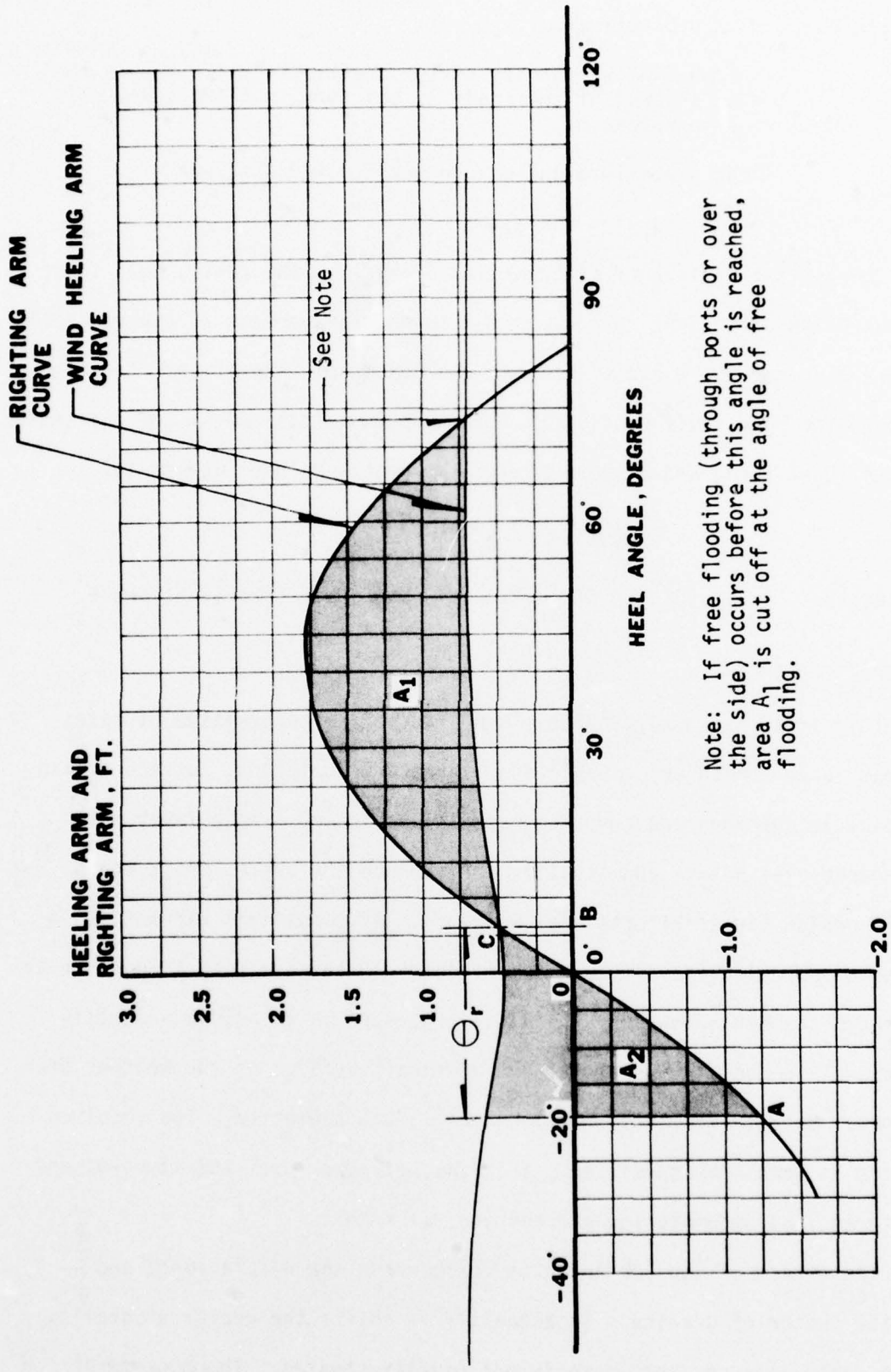

Note: If free flooding (through ports or over the side) occurs before this angle is reached, area A<sub>1</sub> is cut off at the angle of free flooding.

FIGURE 17  
WIND HEELING ARM CURVE

Where:  $\Delta$  = Displacement, lb  
 $v$  = linear velocity of the craft, ft/sec. This is the speed of the craft in the turn, not the speed of approach.  
 $g$  = Acceleration due to gravity, 32.2 ft/sec<sup>2</sup>  
 $R$  = turning radius, ft

The lateral resistance of the hull is equal to the centrifugal force and opposite in direction. The lever for the heeling moment is the vertical distance,  $a$ , between the craft's CG and the center of lateral resistance of the underwater body (half draft), ft. If this is multiplied by the expression for centrifugal force and divided by displacement, the heeling arm is

$$HA = \frac{v^2 a \cos \theta}{g R}$$

Where:  $\theta$  = angle of inclination and other symbols as above.

### 3.6 TOPSIDE ICING

This is an extremely variable condition. Ice accumulates at rates which vary with atmospheric conditions, surface orientation, surface finish (some plastic coatings and coverings accumulate ice at a much lower rate than conventional paints and metals), location on the craft, craft speed and hull design (as it affects deck wetness). If conditions warrant it, a reasonable approximation of the icing effects can be made with a model in an atmospheric chamber. However, the usual procedure is to assume a certain thickness of ice on all horizontal and vertical surfaces on the weather deck and above. Masts, lifelines, fittings, etc., are neglected. The required thickness is sometimes specified. If it is not, two cases are studied; one for a three inch accumulation and one for six inches.

The effect of topside icing is to increase the displacement and raise the center of gravity. In actuality it shifts the center of gravity off the centerline but this case is not usually studied. The procedures for

making these calculations have been outlined in Sections 2.5 and 2.7 above. For this purpose, the approximate average density of ice is taken as 56.7 lb per cubic ft.

Since the stability criteria for topside icing (Section 5.1.5) are based on wind heel, it is sometimes necessary to limit the beam winds in which the craft may operate when iced. The amount of restriction is determined by adjusting the wind heeling arm curve downward until the craft in the iced condition meets the criteria. After this is done the equivalent wind velocity is calculated as follows:

$$V_i = V_0 \times \left( \frac{HA_i}{HA_0} \right)^{1/2}$$

- Where:
- $V_i$  = Maximum allowable wind velocity with specified or assumed thickness of ice.
  - $HA_i$  = Heeling arm at 0° heel from the above trial and error procedure.
  - $HA_0$  = Heeling arm at 0° heel for the design wind condition, no ice.
  - $V_0$  = Design wind velocity, no ice, knots.

The criteria are given in Section 5, below.

#### 4.0 DAMAGE STABILITY

The calculations for damage stability have been completely computerized. A sample of the output is shown in Figure 18. Figure 19 illustrates the quantities which are tabulated in Figure 18. The righting arms are calculated for a specific condition of loading, including the correct VCG and LCG, therefore no corrections have to be made. The righting arms from the print-out are plotted against heel angle and compared to the applicable stability criteria.

SHIP- SHCP SAMPLE SHIP S.S.SUSAN GAIL SERIAL NUMBER- 717 DATE- 6/30/75

DAMAGED STATICAL STABILITY CALCULATIONS

INPUT COMPARTMENT DESCRIPTIONS

| ID  | NAME                    | SYM | PERM | X1D    | X2D    | Y1D     | Y2D     | Z1D      | Z2D   |
|-----|-------------------------|-----|------|--------|--------|---------|---------|----------|-------|
| 101 | ENGINE ROOM 18-36 FEET  | -0  | .90  | 118.00 | 168.00 | 9999.99 | 9999.99 | 18.00    | 36.00 |
| 102 | ENGINE ROOM 4-14 FEET   | -0  | .70  | 118.00 | 168.00 | 9999.99 | 9999.99 | 4.00     | 14.00 |
| 200 | FIRE ROOM               | -0  | .90  | 168.00 | 216.00 | 9999.99 | 9999.99 | 16.00    | 36.00 |
| 201 | WATER TK. FULL 1/3 LV   | 1   | -.03 | 168.00 | 216.00 | 9999.99 | 9999.99 | 11.11.44 | 12.00 |
| 202 | DEDUCT FIRE ROOM FROM 2 | 1   | -.03 | 168.00 | 216.00 | 9999.99 | 9999.99 | 9999.99  | 12.00 |
| 203 | WATER TK. HT 2/3 TOP    | 1   | -.98 | 168.00 | 216.00 | 9999.99 | 9999.99 | 12.00    | 36.00 |
| 204 | DEDUCT FIRE ROOM FROM 2 | 1   | -.98 | 168.00 | 216.00 | 9999.99 | 9999.99 | 12.00    | 36.00 |
| 303 | STORE ROOM              | -0  | .85  | 216.00 | 256.00 | 9999.99 | 9999.99 | 24.00    | 36.00 |
| 304 | FUEL OIL FULL BOTTOM    | -0  | .88  | 216.00 | 256.00 | 9999.99 | 9999.99 | 9999.99  | 24.00 |
| 306 | FUEL OIL FULL           | -0  | .98  | 216.00 | 256.00 | 20.00   | 9999.99 | 24.00    | 36.00 |

CONDITION 1 COMPARTMENTS INCLUDED 101 102 200 201 202 203 204 303 304 306

COMPARTMENT AND INTACT SHIP PROPERTIES AT BALANCE CONDITION

| HEEL  | DRAFT  | TRIM  | I.O. | DISPL     | VOLUME    | TCB    | VCB    | LCB     |
|-------|--------|-------|------|-----------|-----------|--------|--------|---------|
| 20.00 | 30.029 | 6.791 | 101  | 1239.896  | 43390.38  | 17.026 | 25.791 | 6.705   |
|       |        |       | 102  | 839.138   | 29369.82  | .434   | 11.496 | 6.775   |
|       |        |       | 200  | 1746.441  | 61125.43  | 8.489  | 21.610 | -41.428 |
|       |        |       | 201  | 7.730     | 270.54    | 11.345 | 8.255  | -3.108  |
|       |        |       | 202  | -2.966    | -103.80   | 7.840  | 9.874  | -33.214 |
|       |        |       | 203  | 1338.463  | 46840.21  | 22.293 | 24.318 | -41.777 |
|       |        |       | 204  | -1106.562 | -40824.67 | 13.385 | 24.615 | -41.317 |
|       |        |       | 303  | 245.673   | 10348.56  | 5.261  | 28.715 | -35.303 |
|       |        |       | 304  | 915.163   | 32030.71  | 1.333  | 16.432 | -13.542 |
|       |        |       | 306  | 281.428   | 9849.99   | 30.342 | 30.266 | -34.316 |
|       |        |       | INT  | 11978.741 | 419255.94 | 10.010 | 21.793 | -4.157  |

CONDITION 1 COMPARTMENTS INCLUDED 101 102 200 201 202 203 204 303 304 306

NET DAMAGED SHIP PROPERTIES

| DISPL   | LCG   | POLE HT | HEEL   | KA     | TCB    | VCB    | LCB   | DRAFT  | TRIM    |
|---------|-------|---------|--------|--------|--------|--------|-------|--------|---------|
| 7739.81 | 4.828 | 26.00   | 0.00   | -.430  | -.830  | 20.501 | 4.614 | 33.208 | 11.609  |
|         |       |         | 5.00   | 1.182  | 1.658  | 20.609 | 4.633 | 32.883 | 13.869  |
|         |       |         | 10.00  | 3.394  | 4.335  | 20.960 | 4.665 | 32.134 | 4.698   |
|         |       |         | 15.00  | 5.532  | 6.924  | 21.532 | 4.703 | 31.181 | 3.339   |
|         |       |         | 20.00  | 7.555  | 9.384  | 22.305 | 4.745 | 30.029 | 6.791   |
|         |       |         | >30.00 | 11.253 | 13.419 | 24.398 | 4.811 | 26.989 | 3.046   |
|         |       |         | 40.00  | 14.008 | 17.523 | 26.909 | 4.826 | 22.859 | -.653   |
|         |       |         | 50.00  | 15.623 | 20.127 | 29.506 | 4.782 | 17.289 | -4.012  |
|         |       |         | 60.00  | 16.270 | 21.956 | 32.110 | 4.573 | 8.492  | -7.534  |
|         |       |         | 70.00  | 16.180 | 23.205 | 34.773 | 4.434 | -6.279 | -13.437 |

FIGURE 18  
 SAMPLE DAMAGE STABILITY OUTPUT  
 FROM SHIP HULL CHARACTERISTICS PROGRAM

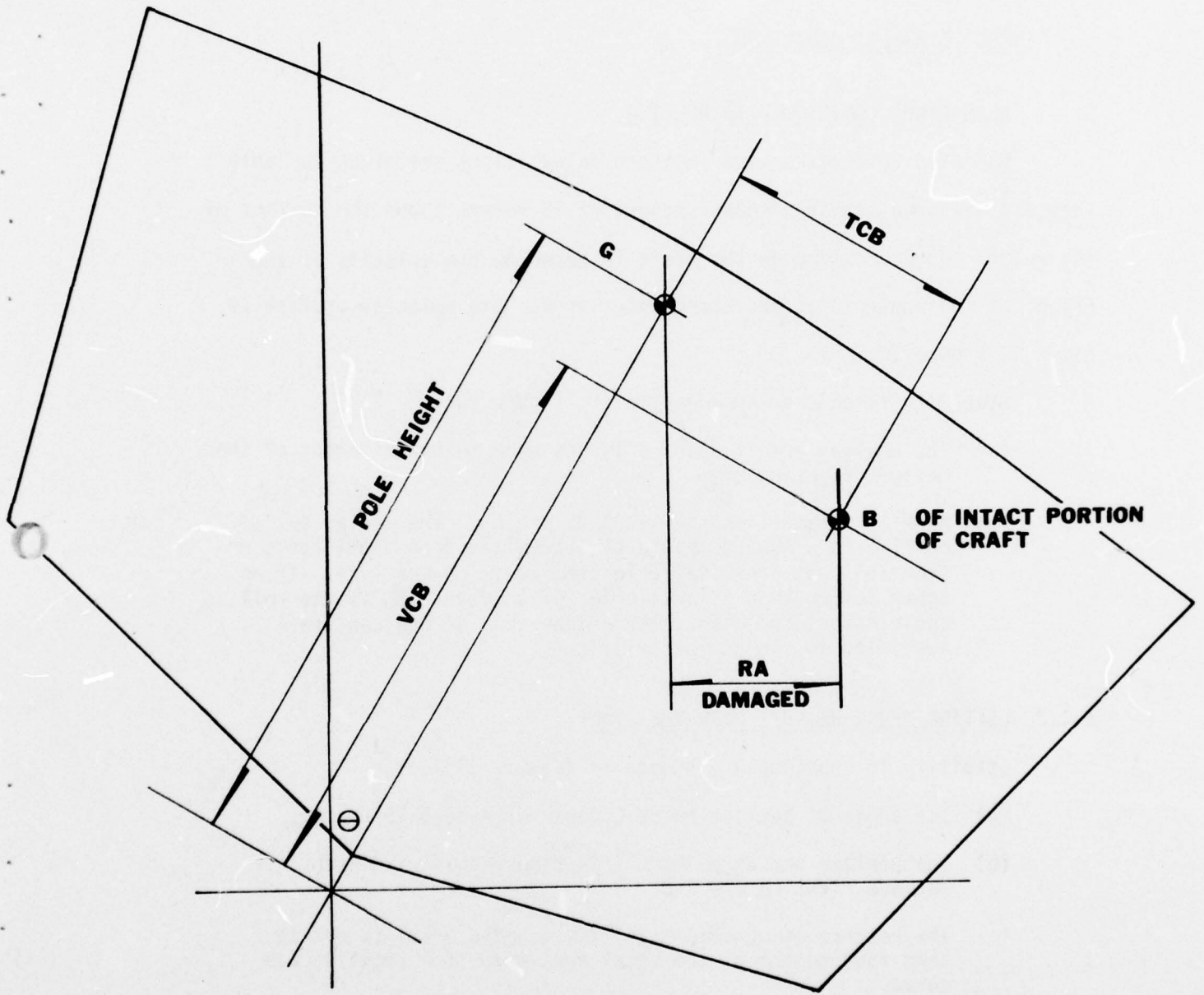

**FIGURE 19**  
**DAMAGED CENTER OF BUOYANCY**

## 5.0 STABILITY CRITERIA

These stability criteria are taken from References 1 and 2 which should be consulted for a more complete understanding of the subject.

### 5.1 INTACT STABILITY CRITERIA

#### 5.1.1 BEAM WINDS COMBINED WITH ROLLING

The wind velocities used in these calculations are given in Table 1. They are measured at the standard height of 10 meters above the surface of the water. Wind pressure on the craft is based on the velocity at the height of the centroid of the above water area. The velocity profile is given in Figure 14.

Stability is considered adequate if (Figure 20):

- (a) The heeling arm at point C is not more than six tenths of the maximum righting arm.
- (b) Area  $A_1$  is not less than 140% of area  $A_2$ . The angle,  $\theta_r$ , of rolling to windward should be determined from model tests or from the best data available from craft of the type. If no other information is available  $25^\circ$  is used.  $\theta_r$  is the roll angle associated with fully arisen seas of the sea state specified in the characteristics.

#### 5.1.2 LIFTING HEAVY WEIGHTS OVER THE SIDE

Stability is considered adequate if (Figure 21):

- (a) The angle of heel at point C does not exceed  $15^\circ$ .
- (b) The heeling arm at point C is not more than six tenths the maximum righting arm and
- (c) The reserve of dynamic stability (shaded area) is not less than four tenths of the total area under the righting arm curve.

#### 5.1.3 CROWDING OF PASSENGERS TO ONE SIDE

Stability is considered adequate if (Figure 21):

- (a) The angle of heel at point C does not exceed  $15^\circ$ .

Table 1. Wind Velocities

| Service  | Minimum wind velocity for design purposes (knots) | Minimum Acceptable wind velocity for craft after 5 years in service (knots) |
|--|---|---|
| 1. Ocean   |   |   |
| (a) Craft which will be expected to weather full force of tropical cyclones. This includes all craft which will move with the amphibious and striking forces | 100   | 90  |
| (b) Craft which will be expected to avoid centers of tropical disturbances   | 80  | 70  |
| 2. Coastwise   |   |   |
| (a) Craft which will be expected to weather full force to tropical cyclones  | 100   | 90  |
| (b) Craft which will be expected to avoid centers of tropical disturbances, but to stay at sea under all other circumstances of weather                      | 80  | 70  |
| (c) Craft which will be recalled to protected anchorages if winds over Force 8 are expected  | 60  | 50  |
| 3. Harbor  | 60  | 50  |

Taken from Reference 1 & 2

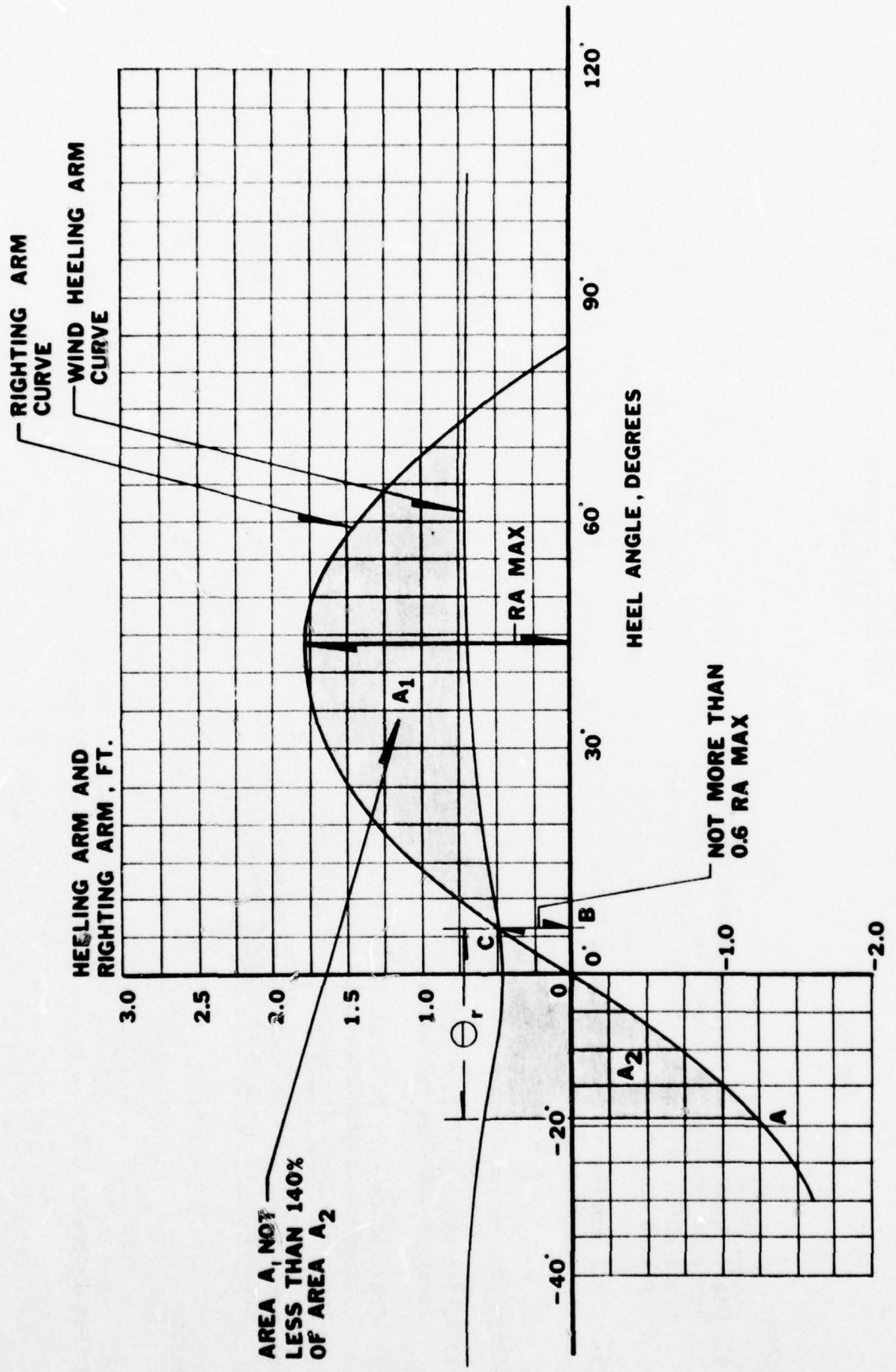
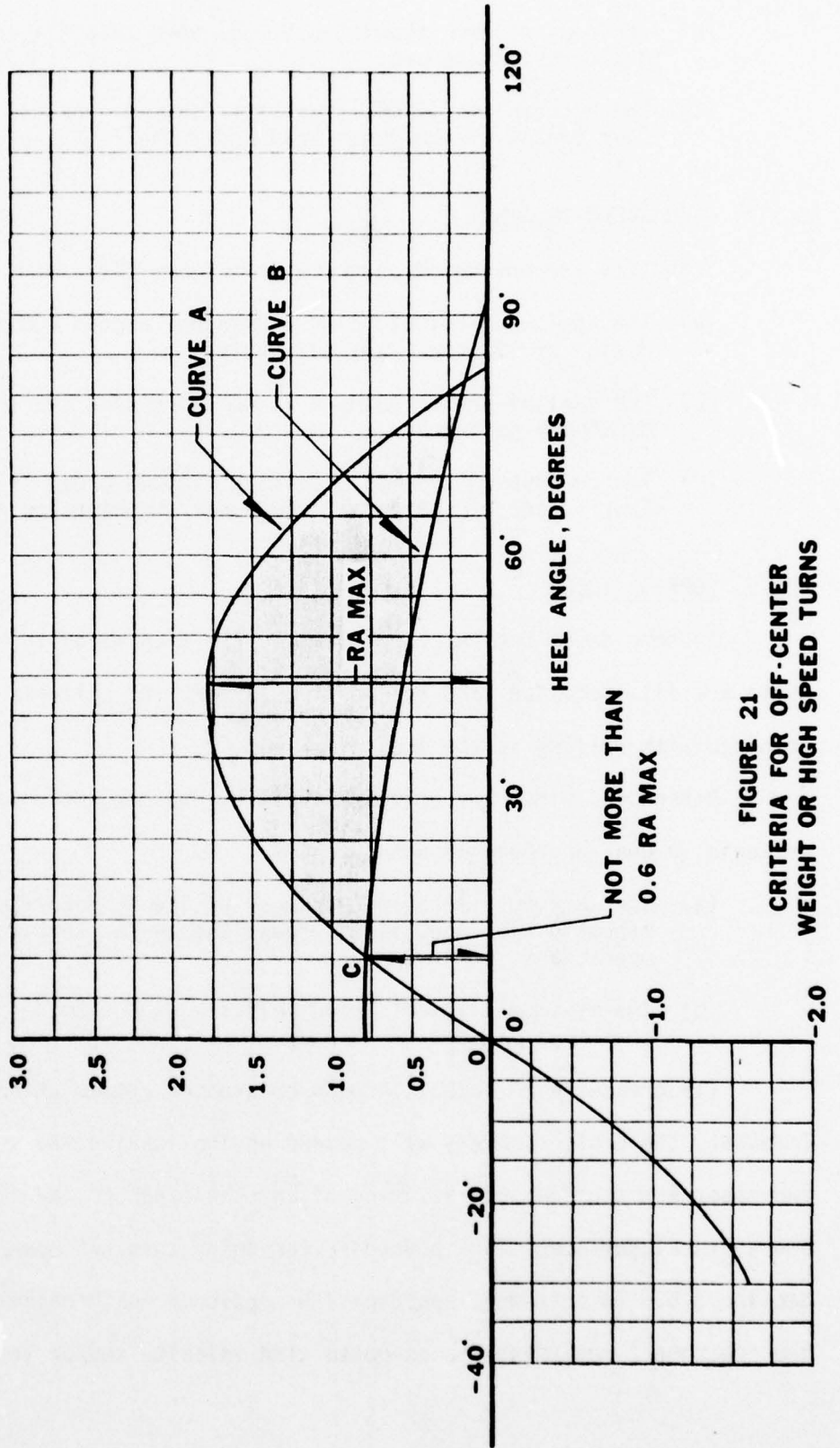

FIGURE 20  
 CRITERIA FOR BEAM WINDS  
 COMBINED WITH ROLLING

**CURVE A - GZ FOR CRAFT WITH CG ON CENTERLINE**

**CURVE B - HA CURVE DUE TO OFF-CENTER WEIGHT OF PASSENGERS OR HOISTING WEIGHT OVER SIDE, OR HIGH SPEED TURN.**

**HEELING ARMS AND RIGHTING ARMS, FT.**



**FIGURE 21  
CRITERIA FOR OFF-CENTER  
WEIGHT OR HIGH SPEED TURNS**

- (b) The heeling arm at point C is not more than six tenths of the maximum righting arm.
- (c) The reserve of dynamic stability (shaded area) is not less than four tenths of the total area under the righting arm curve.

#### 5.1.4 HIGH-SPEED TURNING

Stability is considered adequate if (Figure 21):

- (a) The angle of heel at point C does not exceed 10° for a new design or 15° for craft in service.
- (b) The heeling arm at point C is not more than six tenths of the maximum righting arm.
- (c) The reserve of dynamic stability (shaded area) is not less than four tenths of the total area under the righting arm curve.

#### 5.1.5 TOPSIDE ICING

In some cases the thickness of ice, the wind velocity, and the sea state are all specified, and the craft must meet the criteria for beam wind combined with rolling in the iced condition.

Otherwise, since the craft's stability has been determined by other criteria, a dual approach is used:

- (a) The maximum allowable thickness of ice is determined for the probable wind conditions prevailing in the specified area of operations, or
- (b) The maximum allowable wind velocity is determined for an assumed thickness of ice.

(If greater wind velocities and/or greater accumulations of ice are forecast, the craft's safety will depend on its leaving the area.) Usually two cases are studied: one assuming 3" and the other 6" ice on all horizontal and vertical surfaces. The procedure for doing this has been outlined in Section 3.6. In this dual approach, the designer must receive guidance from the "customer" regarding the expected wind velocity and/or ice accumulation.

## 5.2 DAMAGE STABILITY CRITERIA

Reference 1 states that new designs without side protective systems must meet the following subdivision criterion:

- (a) Seagoing craft less than 100 ft in length shall be capable of withstanding, as a minimum, the flooding of any single main compartment.
- (b) Craft between 100 and 300 ft in length shall be capable of withstanding, as a minimum, the flooding of any two adjacent main compartments.

Every effort is made to exceed this minimum requirement even for craft under 100 ft, because damage is almost as likely to occur at a bulkhead (thus flooding two compartments) as between bulkheads.

Once this criterion (called the standard of subdivision) has been established, the stability of the craft in the damaged condition can be evaluated. This is done for all the most severe combinations of flooded compartments.

Referring to Figure 22, stability shall be considered adequate if:

- (a) The initial angle of heel after damage, point C, caused by either negative initial stability or unsymmetrical flooding, does not exceed  $15^\circ$ .
- (b) The available reserve dynamic stability beyond point D and up to angle  $\theta$  (shaded area) is not less than the amount shown in Figure 23. If scales of  $1'' = 1'$  righting arm and  $1'' = 20^\circ$  heel are used, the required area in actual square inches on the drawing can be obtained from Figure 23.

The angle,  $\theta$ , in Figure 22 is  $45^\circ$  or the angle at which unrestricted flooding occurs, whichever is less.

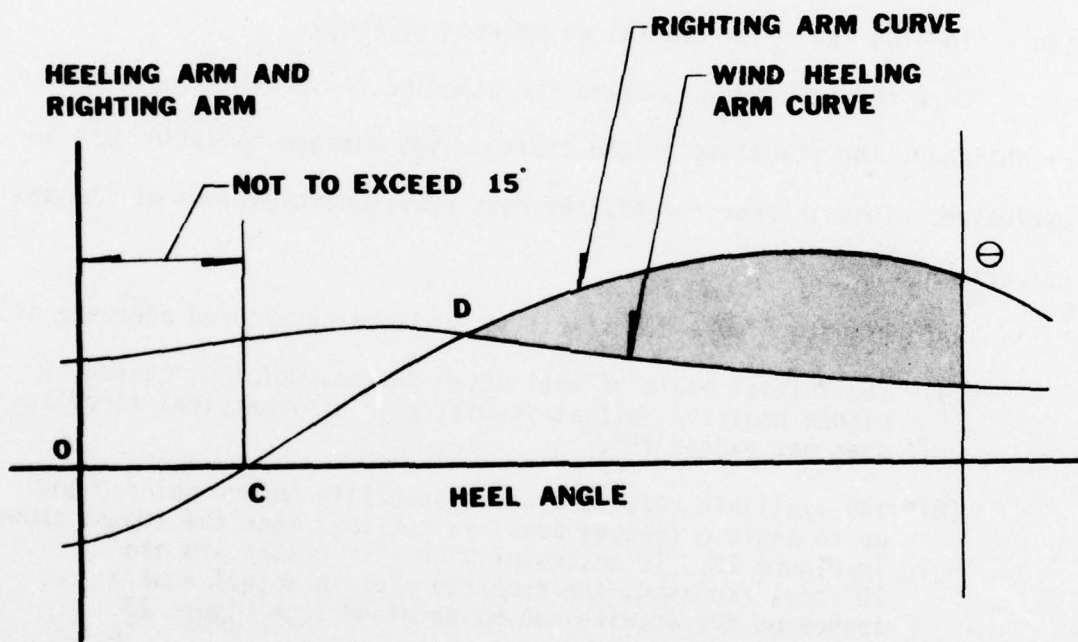

$\theta$  AND A  $\rho_s$  DEFINED IN SECTION 5.2

**FIGURE 22  
DAMAGED STABILITY CRITERIA**

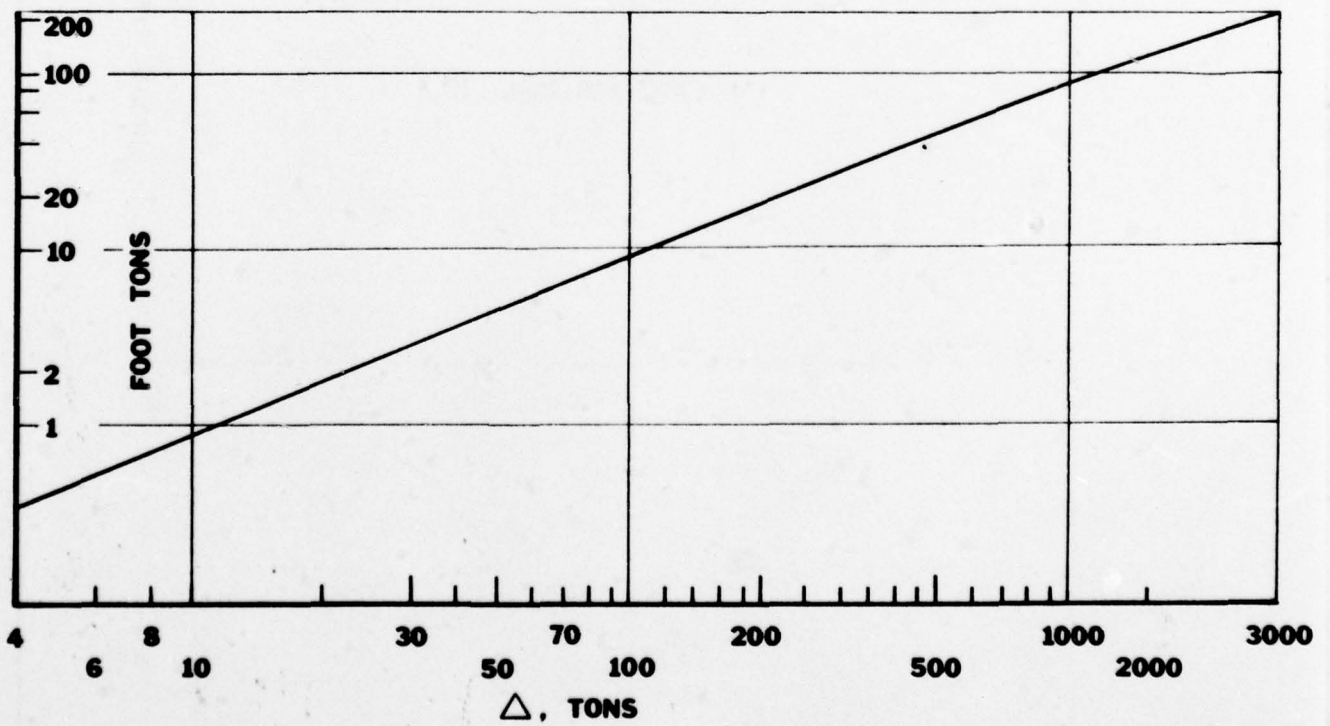
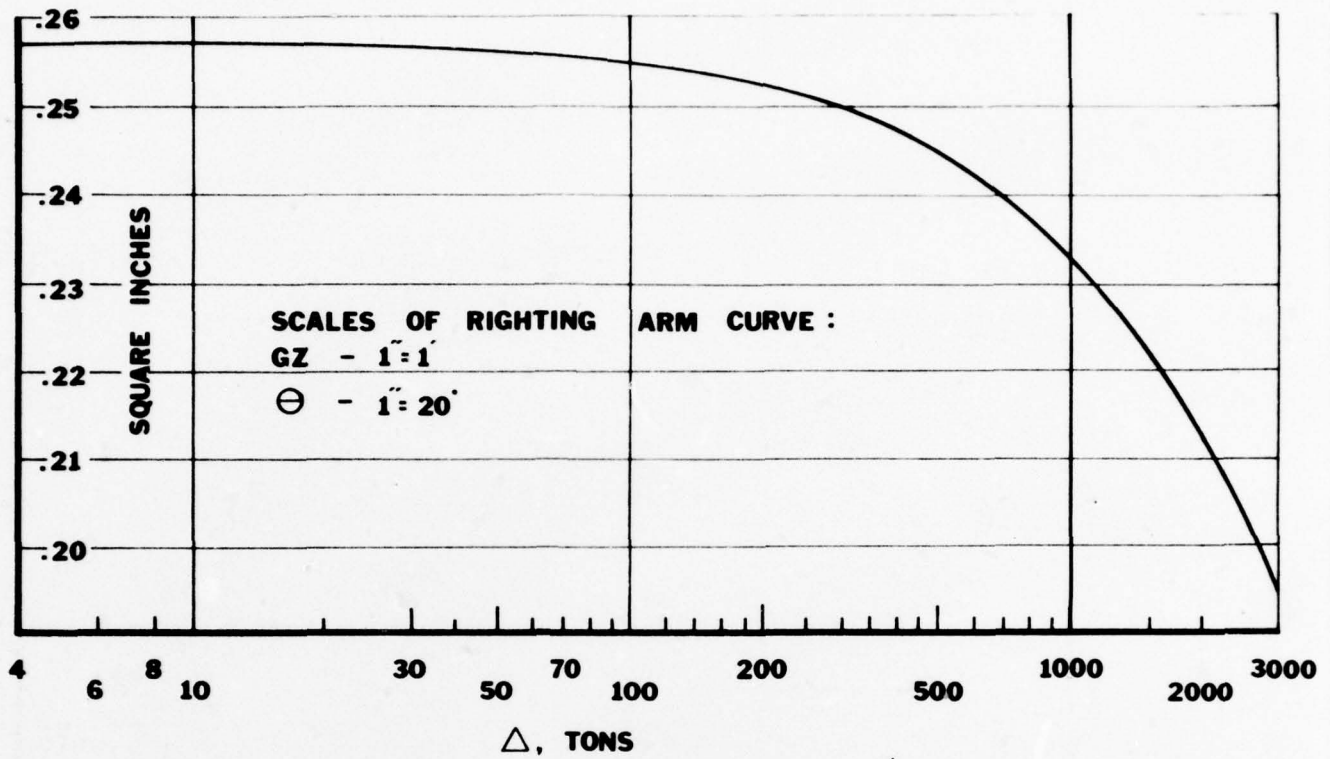

**FIGURE 23**  
**REQUIRED STABILITY**  
**IN DAMAGED CONDITION**

PART II

PROCEDURE FOR ANALYSIS

PART II - PROCEDURE FOR ANALYSIS

6.0 DATA REQUIRED FOR STABILITY ANALYSIS

6.1 INTACT STABILITY

6.1.1 BEAM WINDS COMBINED WITH ROLLING

| <u>Item</u>                 | <u>Source</u>          |
|-----------------------------|------------------------|
| Profile & Bow View of Craft | Drawing File           |
| Cross curves of stability   | Drawing File           |
| Displacement and VCG        | Weight control file    |
| Roll angle                  | Sections 3.4 and 5.1.1 |
| GM                          | Weight control file    |

6.1.2 LIFTING HEAVY WEIGHTS OVER THE SIDE

| <u>Item</u>                            | <u>Source</u>           |
|--|-------------------------|
| Location of attachment of load to boom | Rigging drawing         |
| Amount of weight to be lifted          | Operational Requirement |
| Cross curves                           | Drawing file            |
| Displacement and VCG                   | Weight control file     |

6.1.3 CROWDING OF PASSENGERS TO ONE SIDE

| <u>Item</u>                                 | <u>Source</u>           |
|---|-------------------------|
| Plan of deck areas accessible to passengers | Drawing File            |
| Number of passengers                        | Operational Requirement |
| Cross curves                                | Drawing File            |
| Displacement and VCG                        | Weight Control File     |

6.1.4 HIGH SPEED TURNING

| <u>Item</u>            | <u>Source</u>           |
|------------------------|-------------------------|
| Speed of craft in turn | Operational Requirement |
| Radius of turn         | Operational Requirement |
| Cross curves           | Drawing File            |
| Displacement and VCG   | Weight Control File     |

### 6.1.5 TOPSIDE ICING

| <u>Item</u>   | <u>Source</u>           |
|---|-------------------------|
| Maximum expected wind velocity and/<br>or ice thickness in area of<br>operation | Operational Requirement |
| Roll angle  | Sections 3.4 and 5.1.1  |
| Cross curves  | Drawing File            |
| Displacement and VCG  | Weight Control File     |

### 6.2 DAMAGE STABILITY

| <u>Item</u>   | <u>Source</u>   |
|---|-----------------|
| Damaged righting arms in various<br>conditions      | Computer output |
| Roll angle  | Section 5.2     |
| Heel angle at which unrestricted<br>flooding occurs | *               |

### 7.0 ANALYSIS PROCEDURE

The basic procedure is always to compare the characteristics of two curves:

- Righting Arm Curve - reflects conditions internal to the craft, CG on centerline.
- Heeling Arm Curve - reflects conditions external to the craft, and/or CG off centerline.

### 7.1 RIGHTING ARM CURVE

STEP 1. Determine the exact displacement for which the investigation is to be made. This may require adding weights, such as a hoisted load or ice, to the load condition reported on the weight summary sheets of the "ESTIMATE OF WEIGHT FOR BOATS". The total

---

\*This is determined by checking the actual waterline in the damaged condition (from the damaged stability computer output) against the craft arrangement drawings.

displacement and center of gravity location may be calculated on Form 1 (See Appendix), or other suitable form.

STEP 2. Enter the craft condition, displacement and KG in the blocks provided on Form 2.

STEP 3. Enter in Column 1 each angle for which the cross curves have been plotted. If desired, for hand calculations, enter the sine of each angle in Column 2.

STEP 4. Multiply KG by the sine of each heel angle,  $\theta$ , and enter in Column 3.

STEP 5. Enter the cross curves at the value of displacement found in Step 1 above, and read the value of righting arm, RA, for each heel angle. Enter these values on Form 2 in Column 4.

STEP 6. Subtract  $KG \sin \theta$  (Col. 3) from RA to get GZ and enter in Column 5.

STEP 7. Plot the righting arm curve (from Step 6) on Form 4.

## 7.2 HEELING ARM CURVES

### 7.2.1 WIND HEEL

STEP 1. Prepare a simplified outboard profile and end view of the craft, similar to Figure 15.

STEP 2. Block out the profile in the minimum number of rectangular planes that will represent the projected sail area.

STEP 3. Locate these planes on the end view.

STEP 4. Construct the lateral projections of these planes at a few heel angles, say  $30^\circ$ ,  $60^\circ$  and  $90^\circ$ . For this purpose the craft can be considered to remain at constant trim, to rotate about the CG with the waterline a constant distance below the CG. For

convenience in simplifying the areas it may be desirable to trace them roughly as shown in Figure 16. Calculate these areas and enter them in Column 1 of Form 3.

STEP 5. Locate the centroid of the sail area, and the half draft point at each heel angle. (Note that the draft changes with heel angle.) Measure the vertical distance,  $h$ , between the two at each heel angle, and enter this in Column 2 of Form 3.

STEP 6. Multiply the distance,  $h$ , by the projected sail area,  $A$ , at each heel angle and enter the product in Column 3 of Form 3.

STEP 7. Calculate the wind pressure,  $p$ , in pounds per square foot, from the formula  $p = 0.004 V_k^2$ , for one or more wind velocities as specified. Figure 14 should be used to obtain the correct local velocity at the centroid of area,  $A$ , for the specified velocity (which is taken at a height of 10 meters).

STEP 8. Multiply the pressure,  $p$ , by the area moment in Column 3 to get the heeling moment. Enter this in Column 4.

STEP 9. Divide the values in Column 4 by the displacement of the craft to obtain heeling arms and enter these in Column 5. NOTE: The reason for separating the procedure into such a large number of steps is to facilitate additional calculations for different displacements and/or wind velocities. Any equivalent procedure may be used.

STEP 10. Plot the heeling arms on the righting arm curve, Form 4.

STEP 11. Note the angle of intersection of the two curves.

STEP 12. Lay off angle,  $\theta_r$ , as defined in Section 5.1.1.

STEP 13. Measure areas  $A_1$  and  $A_2$  as shown in Figure 20.

STEP 14. Divide  $A_1$  by  $A_2$ , and note ratio.

STEP 15. Divide the heeling arm at point C by the maximum righting arm, and note ratio.

#### 7.2.2 OFF-CENTER WEIGHT

It is assumed that a righting arm curve has been plotted for the correct displacement and vertical center of gravity, including the effects of added or swinging weights, etc., as described in Sections 2.5, 2.7, and 3.2.

STEP 1. List the amount of off-center weight, its distance off center, and the displacement in the correct places at the head of Form 5, and calculate GG' as shown.

STEP 2. Enter the desired number of heel angles in Column 1 and their cosines in Column 2. Multiply GG' by the cosine of each heel angle and enter the values in Column 3 of Form 5.

STEP 3. Plot the values from Column 3 on the righting arm curve, Form 4, for the condition under investigation.

STEP 4. Note the angle of intersection of the two curves at point C, as shown in Figure 10(A), on page 19.

STEP 5. Divide the heeling arm at point C by the maximum righting arm and note the ratio.

STEP 6. Measure the area between the curves and the total area under the righting arm curve, divide the former by the latter, and note the ratio.

#### 7.2.3 HIGH SPEED TURNING

STEP 1. Obtain the vertical distance,  $a$ , from the half draft point to the vertical center of gravity.

STEP 2. Using the distance,  $a$ , the craft speed,  $v$ , and the turning radius,  $R$ , calculate the heeling arm for each of several

heel angles using the formula  $HA = v^2 a \cos \theta / gR$ . Tabulate all calculations as shown on Form 6. ( $v = 1.69 V_k$ )

STEP 3. Plot the values from Column 6 on the righting arm curve for the condition under investigation. Use Form 4.

STEP 4. Note the angle, point C, at which the heeling arm curve and righting arm curve intersect.

STEP 5. Divide the heeling arm at point C by the maximum righting arm and note the ratio.

STEP 6. Measure the area between the curves and the total area under the righting arm curve, divide the former by the latter, and note the ratio.

### 7.3 DAMAGE STABILITY

STEP 1. Plot the damage righting arms, as given in the computer print-out, on a copy of Form 4.

STEP 2. Plot the wind heel curve, based on the projected areas, and calculated for the specified wind velocity, on the righting arm curve.

STEP 3. Note the intersection of the two curves.

STEP 4. Measure the area between the curves, and check it against the required area from Figure 23.

### REFERENCES

1. Sarchin, T. H., and Goldberg, L. L., "Stability and Buoyancy Criteria for U.S. Naval Surface Ships," SNAME 1962
2. Goldberg, L. L., and Tucker, R. G., "Current Status of U. S. Navy Stability and Buoyancy Criteria for Advanced Marine Vehicles," AIAA/SNAME Advanced Marine Vehicles Conference, San Diego 1974

EXAMPLE CALCULATION

## EXAMPLE CALCULATION

The following example calculation has been prepared to clarify the procedure and illustrate one way to carry out the calculations outlined in Section 7. Other ways are possible, especially if an electronic calculator is used. Examples of two possible differences are:

- The trigonometric functions of the heel angles need not be tabulated.
- The sail area and its moment arm need not be tabulated separately.

In the process of summing the individual smaller rectangles which make up the total sail area at a given heel angle, their moments may be taken about the half draft point. The sum of these moments is  $Ah$  as given on Form 3, and this may be multiplied by  $p/\Delta$  and entered directly in column (5) for the heel angle in question.

This example calculation is for a craft which approximates CPIC-X. The numbers used are not in exact agreement with any particular weight report and are not entirely consistent within themselves, but will serve well enough as an illustration.

In carrying out a stability calculation, the values for displacement, GM, etc., are found on one of the summary sheets in the Estimate of Weight for Boats, or a similar report in the weight control file. The calculation carried out on Form 1 would normally be on one of the summary sheets but is used here simply as an illustration of the summation of weights and moments. The load item shown is itself a summation of many smaller items.

After determining the new loading condition for which the stability is to be calculated, the new GM must be determined as described on Form 1 of this sample calculation. Note that the VCG shift (i.e., the KG shift) is not applied

directly to the old GM because KM changes with a change in displacement.  
At a particular displacement  $GM = KM - KG$ .\*

The value of GM thus found is plotted at  $57.3^\circ$  on Form 4, as shown in the example, and a line is drawn from that point through the origin. The righting arm curve must be tangent to this line at the origin.

The work carried out on each of the sheets follows the outline in Section 7, therefore the procedure will not be repeated. If the forms and the procedure outline are studied together their use will become clear.

---

\* It may be convenient to use a blank copy of one of the summary sheets (pages 2, 3 or 4) as these provide blanks for the calculation of GM, trim, and other hydrostatic characteristics.



# BEST AVAILABLE COPY

EXAMPLE

Page 9 of 11

## CROSS CURVES OF STABILITY

ARM ASSUMED 0 FEET ABOVE REFERENCE LINE  
 SHIP CONSIDERED WATERLOOFT TO Main Deck

Form OTIC-X

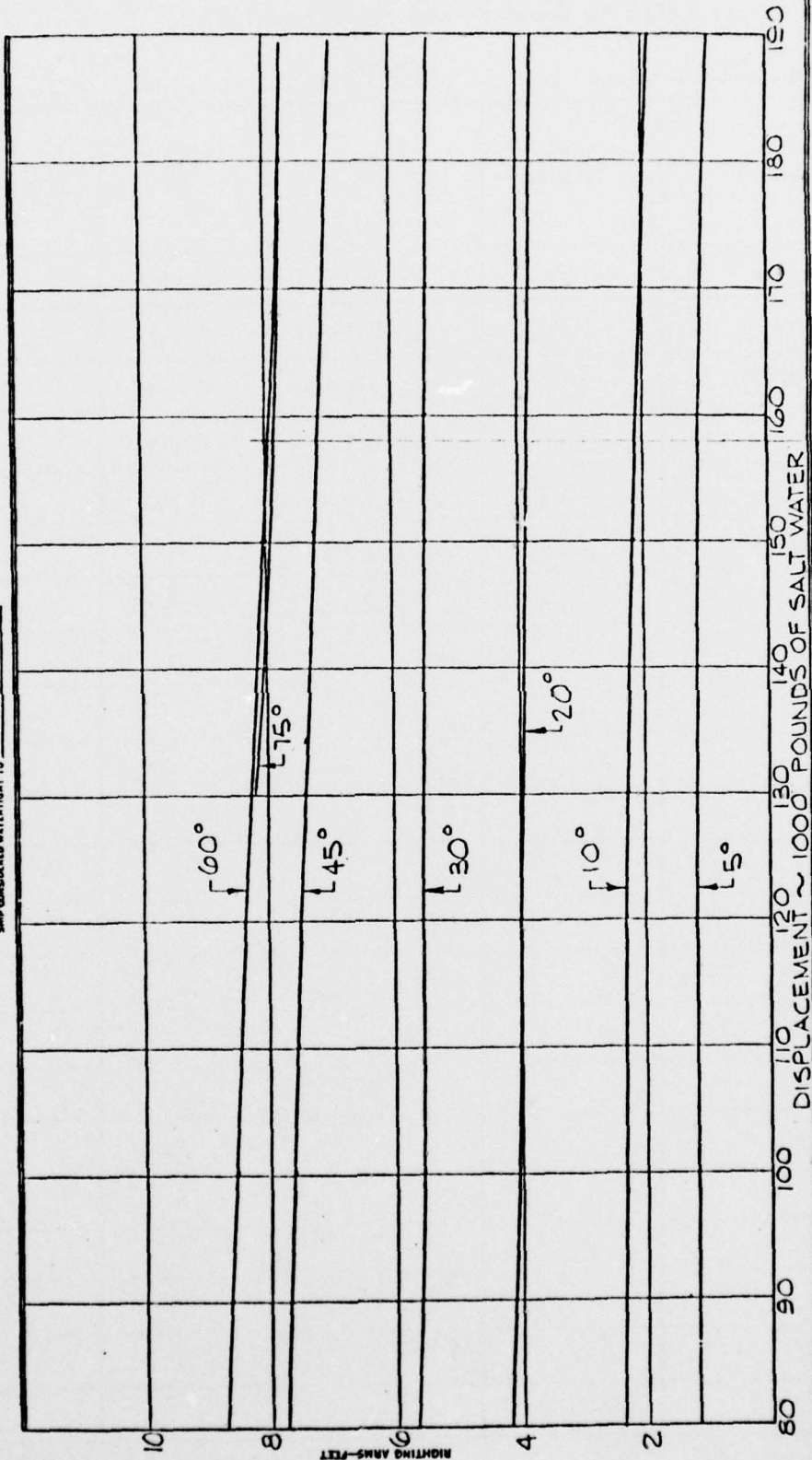

READ RIGHTING ARMS FOR  
 DISP = 158,000 LB = 70.40 TONS  
 ENTER THEM ON FORM 2 IN COL. (4)

REMARKS (if desired):

REMARKS ON THIS FORM MUST BE IN COL. (4) OF FORM 2

**BEST AVAILABLE COPY**

STABILITY ANALYSIS

EXAMPLE  
FORM NO. 2

RIGHTING ARM CALCULATION  
(Correction to Cross Curves for VCG shift)

CRAFT CPIC-X

REMARKS \_\_\_\_\_

|   | (1)<br>Heel, $\theta$ | (2)<br>Sin $\theta$ | (3)<br>KG Sin $\theta$ | (4)<br>RA | (5)<br>(4)-(3) = GZ |
|---|-----------------------|---------------------|------------------------|-----------|---------------------|
| CRAFT CONDITION <u>D (w/ FUEL AFT)</u><br>DISPLACEMENT <u>70,40 TONS</u><br>KG <u>5,14 FT</u> | 5                     | .0872               | .709                   | 1.08      | .37                 |
|   | 10                    | .1736               | 1.413                  | 2.10      | .69                 |
|   | 20                    | .3420               | 2.784                  | 3.94      | 1.16                |
|   | 30                    | .5000               | 4.070                  | 5.45      | 1.38                |
|   | 45                    | .7071               | 5.756                  | 7.12      | 1.36                |
|   | 60                    | .8660               | 7.049                  | 7.95      | .90                 |
|   | 75                    | .9659               | 7.863                  | 7.83      | - 0.03              |
| CRAFT CONDITION _____<br>DISPLACEMENT _____<br>KG _____                                       |                       |                     |                        |           |                     |
|   |                       |                     |                        |           |                     |
|   |                       |                     |                        |           |                     |
|   |                       |                     |                        |           |                     |
|   |                       |                     |                        |           |                     |
|   |                       |                     |                        |           |                     |
|   |                       |                     |                        |           |                     |
|   |                       |                     |                        |           |                     |
|   |                       |                     |                        |           |                     |
|   |                       |                     |                        |           |                     |

Sheet No. 2 of 6

Prepared By W. T. Hatfield

Date 1/14/77

Checked By C. NOBLE

STABILITY ANALYSIS

EXAMPLE  
FORM NO. 3

WIND HEEL CALCULATIONS

BEST AVAILABLE COPY

CRAFT SPIC-X

REMARKS

CONDITION D (w/ FUEL AFT) DESIGN WIND SPEED 60 KT, AT 10 m.

WIND SPEED FOR CALC.  $V_h$  48 KT, AT CENTROID OF SAIL AREA (av. 6.4' ABOVE W.L.)

WIND PRESS.\*  $p = 0.004 V_h^2 = 0.004(48)^2 = 9.22$  lb/ft<sup>2</sup>  $\Delta = 158,007$  lr

| 0  | A<br>(1) | h<br>(2) | Ah<br>(3) | $V_h$<br>* | p<br>* | pAh<br>(4) | (4): $\Delta$<br>(5) |
|----|----------|----------|-----------|------------|--------|------------|----------------------|
| 0  | 1022     | 7.75     | 7921      |            |        | 73031      | .462                 |
| 30 | 1217     | 8.69     | 10576     |            |        | 79511      | .617                 |
| 60 | 1230     | 8.82     | 10849     |            |        | 100028     | .633                 |
| 90 | 1219     | 9.00     | 10969     |            |        | 101134     | .640                 |
|    |          |          |           |            |        |            |                      |
|    |          |          |           |            |        |            |                      |
|    |          |          |           |            |        |            |                      |
|    |          |          |           |            |        |            |                      |

CONDITION \_\_\_\_\_ DESIGN WIND SPEED \_\_\_\_\_ KT, AT 10 m.

WIND SPEED FOR CALCS,  $V_h$  \_\_\_\_\_ KT, AT CENTROID OF SAIL AREA

WIND PRESS.\*  $p = 0.004 V_h^2 = 0.004( \quad )^2 = \quad$  lb/ft<sup>2</sup>

| 0 | A<br>(1) | h<br>(2) | Ah<br>(3) | $V_h$<br>* | p<br>* | pAh<br>(4) | (4): $\Delta$<br>(5) |
|---|----------|----------|-----------|------------|--------|------------|----------------------|
|   |          |          |           |            |        |            |                      |
|   |          |          |           |            |        |            |                      |
|   |          |          |           |            |        |            |                      |
|   |          |          |           |            |        |            |                      |
|   |          |          |           |            |        |            |                      |
|   |          |          |           |            |        |            |                      |
|   |          |          |           |            |        |            |                      |
|   |          |          |           |            |        |            |                      |

\*Wind pressure should be calculated separately for each heel angle if the height of the centroid of the sail area above the water surface varies more than 10% from the value at 0°.

Sheet No. 3 of 6

Prepared by W.T. Hatch

Date 1/14/77

Checked by C. NOBLE

STABILITY ANALYSIS

EXAMPLE  
FORM NO. 4

$GZ_c = 0.48$  ft at  $7^\circ$  heel

$GZ_{max} = 1.42$  ft at  $37^\circ$  heel

$\frac{GZ_c}{GZ_{max}} = \frac{0.48}{1.42} = 0.34 < 0.6$

Area  $A_1 = 1.60 \text{ IN}^2$   $1.48 > 1.40$

Area  $A_2 = 1.08 \text{ IN}^2$

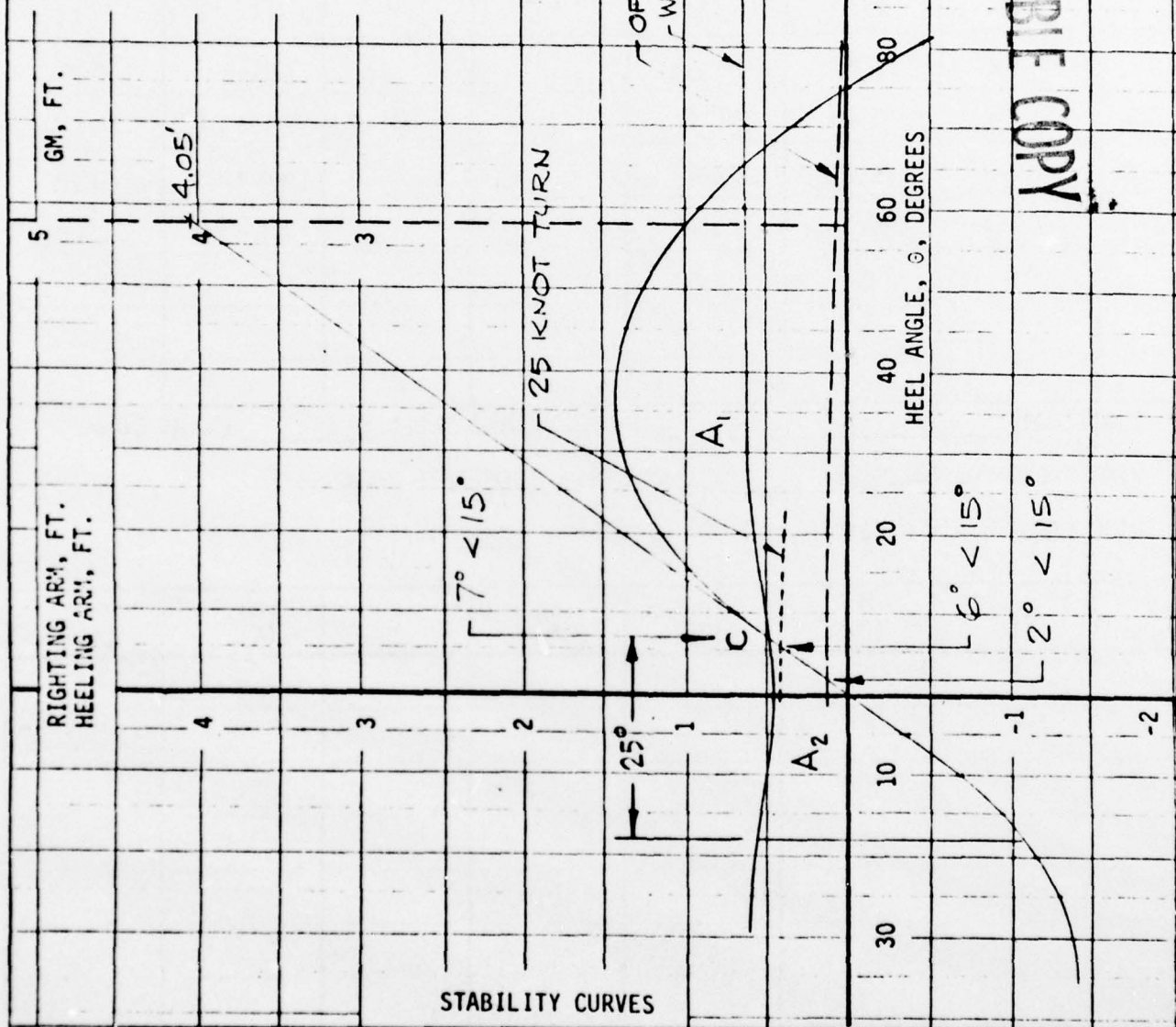

BEST AVAILABLE COPY

CRAFT CPIC-X DISPLACEMENT 70.40 TONS = 158,000 LB

CONDITION D (w/FUCL AFT). GM 4.05 FT

Sheet No. 4 of 6

Date 1/14/77

Prepared by W.T. Hatch

Checked by C. NOBLE



STABILITY ANALYSIS

EXAMPLE  
FORM NO. 6

CALCULATION FOR HIGH SPEED TURN

CRAFT CPIC-X

CONDITION D (w/FUEL AFT)

$$HA = \frac{v^2 a \cos \theta}{gR}$$

Displacement 158,000 lb

v = speed of craft in turn, fps

VCG 8.14 - 6.0 = 2.14 Draft (Hull) 3.3 FT

g = 32.2 ft/sec<sup>2</sup>

R = turning radius, ft.

θ = heel angle

a = dist of VCG above half-draft,  $\frac{2.14}{+ 1.65} = 3.77$  ft.

| (1)<br>v<br>in turn<br>fps    | (2)<br>R *<br>ft | (3)<br>$\frac{v^2 a}{gR}$ | (4)<br>heel<br>θ<br>degrees | (5)<br>cos θ | (6)<br>heeling arm<br>(3) x (5) |
|-------------------------------|------------------|---------------------------|-----------------------------|--------------|---------------------------------|
| <sup>25 x 1.69</sup><br>42.25 | 500              | .420                      | 0                           | 1.000        | .420                            |
|                               |                  |                           | 10                          | .985         | .414                            |
|                               |                  |                           | 20                          | .940         | .395                            |
|                               |                  |                           |                             |              |                                 |
| <sup>35</sup><br>59.15        | 1000             | .412                      | 0                           | 1.000        | .412                            |
|                               |                  |                           | 10                          | .985         | .406                            |
|                               |                  |                           | 20                          | .940         | .387                            |
|                               |                  |                           |                             |              |                                 |
|                               |                  |                           |                             |              |                                 |
|                               |                  |                           |                             |              |                                 |
|                               |                  |                           |                             |              |                                 |
|                               |                  |                           |                             |              |                                 |
|                               |                  |                           |                             |              |                                 |
|                               |                  |                           |                             |              |                                 |
|                               |                  |                           |                             |              |                                 |

BEST AVAILABLE COPY

Sheet No. 6 of 6

Prepared by W.F. Hinch

Date 1/14/77

Checked by C. NOBLE

\* THESE ARE HYPOTHETICAL FIGURES.

APPENDIX

STANDARD FORMS



STABILITY ANALYSIS

FORM NO. 2

RIGHTING ARM CALCULATION  
(Correction to Cross Curves for VCG shift)

CRAFT \_\_\_\_\_

REMARKS \_\_\_\_\_

|   | (1)<br>Heel, $\theta$ | (2)<br>Sin $\theta$ | (3)<br>KG Sin $\theta$ | (4)<br>RA | (5)<br>(4)-(3) = GZ |
|---|-----------------------|---------------------|------------------------|-----------|---------------------|
| CRAFT CONDITION _____<br>DISPLACEMENT _____<br>KG _____ |                       |                     |                        |           |                     |
|   |                       |                     |                        |           |                     |
|   |                       |                     |                        |           |                     |
|   |                       |                     |                        |           |                     |
|   |                       |                     |                        |           |                     |
|   |                       |                     |                        |           |                     |
|   |                       |                     |                        |           |                     |
|   |                       |                     |                        |           |                     |
|   |                       |                     |                        |           |                     |
|   |                       |                     |                        |           |                     |
| CRAFT CONDITION _____<br>DISPLACEMENT _____<br>KG _____ |                       |                     |                        |           |                     |
|   |                       |                     |                        |           |                     |
|   |                       |                     |                        |           |                     |
|   |                       |                     |                        |           |                     |
|   |                       |                     |                        |           |                     |
|   |                       |                     |                        |           |                     |
|   |                       |                     |                        |           |                     |
|   |                       |                     |                        |           |                     |
|   |                       |                     |                        |           |                     |
|   |                       |                     |                        |           |                     |

Sheet No. \_\_\_\_\_ of \_\_\_\_\_

Prepared By \_\_\_\_\_

Date \_\_\_\_\_

Checked By \_\_\_\_\_

STABILITY ANALYSIS

FORM NO. 3

WIND HEEL CALCULATIONS

CRAFT \_\_\_\_\_

REMARKS \_\_\_\_\_

CONDITION \_\_\_\_\_

DESIGN WIND SPEED \_\_\_\_\_ KT, AT 10 m.

WIND SPEED FOR CALC,  $V_h$  \_\_\_\_\_ KT, AT CENTROID OF SAIL AREA

WIND PRESS.\*  $p = 0.004 V_h^2 = 0.004( \quad )^2 = \quad \text{lb/ft}^2$

| $\theta$ | A<br>(1) | h<br>(2) | Ah<br>(3) | $V_h$<br>* | p<br>* | pAh<br>(4) | (4) ÷ Δ<br>(5) |
|----------|----------|----------|-----------|------------|--------|------------|----------------|
|          |          |          |           |            |        |            |                |
|          |          |          |           |            |        |            |                |
|          |          |          |           |            |        |            |                |
|          |          |          |           |            |        |            |                |
|          |          |          |           |            |        |            |                |
|          |          |          |           |            |        |            |                |
|          |          |          |           |            |        |            |                |
|          |          |          |           |            |        |            |                |
|          |          |          |           |            |        |            |                |
|          |          |          |           |            |        |            |                |

CONDITION \_\_\_\_\_

DESIGN WIND SPEED \_\_\_\_\_ KT, AT 10 m.

WIND SPEED FOR CALCS,  $V_h$  \_\_\_\_\_ KT, AT CENTROID OF SAIL AREA

WIND PRESS.\*  $p = 0.004 V_h^2 = 0.004( \quad )^2 = \quad \text{lb/ft}^2$

| $\theta$ | A<br>(1) | h<br>(2) | Ah<br>(3) | $V_h$<br>* | p<br>* | pAh<br>(4) | (4) ÷ Δ<br>(5) |
|----------|----------|----------|-----------|------------|--------|------------|----------------|
|          |          |          |           |            |        |            |                |
|          |          |          |           |            |        |            |                |
|          |          |          |           |            |        |            |                |
|          |          |          |           |            |        |            |                |
|          |          |          |           |            |        |            |                |
|          |          |          |           |            |        |            |                |
|          |          |          |           |            |        |            |                |
|          |          |          |           |            |        |            |                |
|          |          |          |           |            |        |            |                |
|          |          |          |           |            |        |            |                |

\*Wind pressure should be calculated separately for each heel angle if the height of the centroid of the sail area above the water surface varies more than 10% from the value at 0°.

Sheet No. \_\_\_\_\_ of \_\_\_\_\_

Prepared by \_\_\_\_\_

Date \_\_\_\_\_

Checked by \_\_\_\_\_

STABILITY ANALYSIS

FORM NO. 4

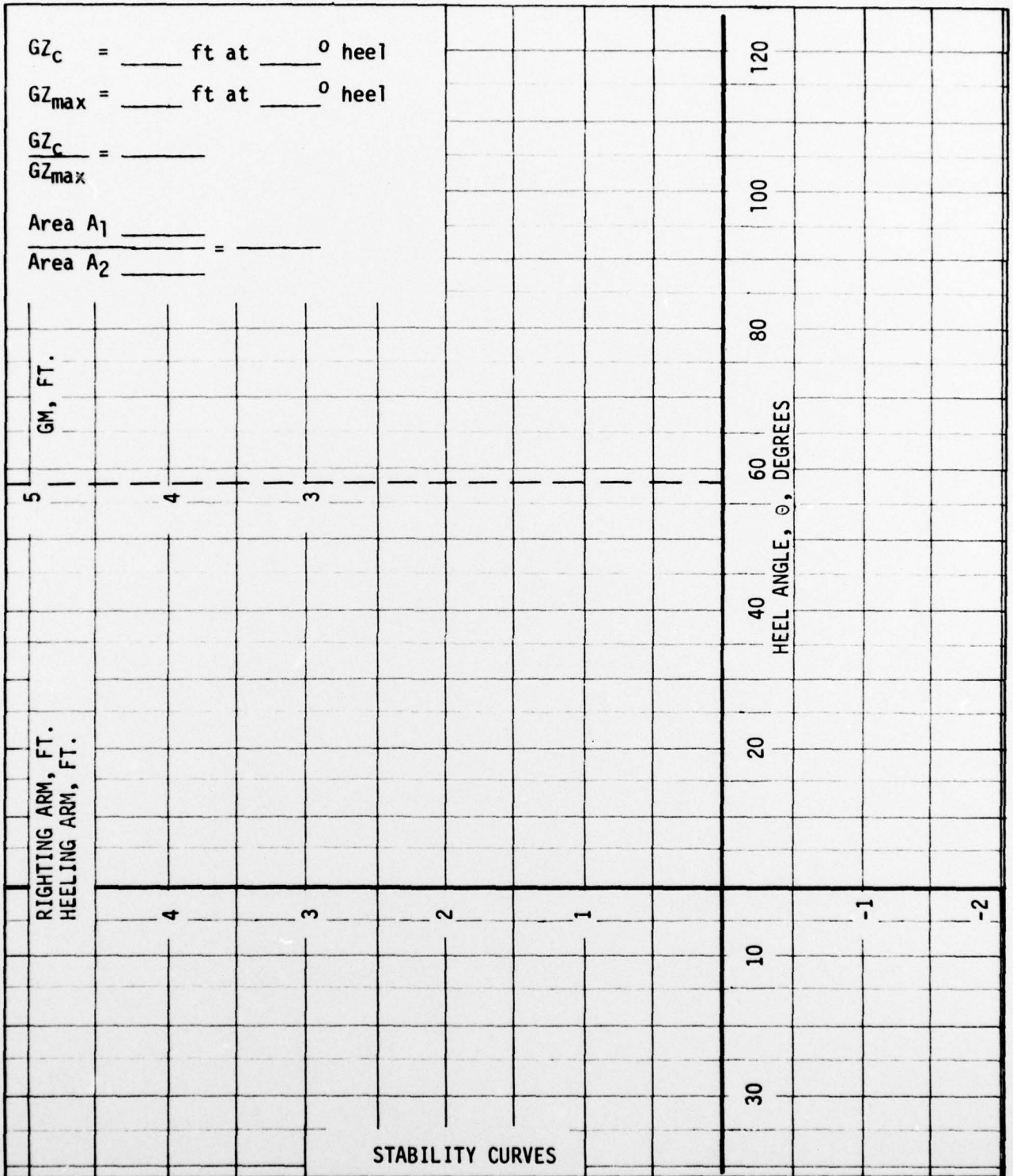

CRAFT                      DISPLACEMENT                     

CONDITION                      GM                     

Sheet No.        of       

Prepared by                                     

Date                                     

Checked by







**ESTIMATE OF WEIGHT FOR BOATS**  
**BOAT IN LIGHT CONDITION - PAGE 1**  
 NAVSHIPS 4816-2 (REV. 11-57)

U.S.S. \_\_\_\_\_

BUDGET BUREAU NO. 45-4281  
 REPORT-BUSHIPS-9291-4

PAGE 1 OF \_\_\_\_\_  
 DATE \_\_\_\_\_

| GROUP   | DESCRIPTION               | WEIGHT<br>(Pounds) | CENTER OF GRAVITY |                      | MOMENTS |
|---|---------------------------|--------------------|-------------------|----------------------|---------|
|   |                           |                    | ABOVE<br>BASE     | REFERRED TO FRAME NO |         |
| 1   | HULL STRUCTURE            |                    |                   |                      |         |
| 2   | PROPULSION                |                    |                   |                      |         |
| 3   | ELECTRIC PLANT            |                    |                   |                      |         |
| 4   | COMMUNICATION AND CONTROL |                    |                   |                      |         |
| 5   | AUXILIARY SYSTEMS         |                    |                   |                      |         |
| 6   | OUTFIT AND FURNISHINGS    |                    |                   |                      |         |
| 7   | ARMAMENT                  |                    |                   |                      |         |
|   | SOFFAGE                   |                    |                   |                      |         |
|   | MARGIN                    |                    |                   |                      |         |
| <b>BOAT IN LIGHT CONDITION</b>                |                           |                    |                   |                      |         |
| BASE ABOVE/BELOW BOTTOM OF KEEL - FEET        |                           |                    |                   |                      |         |
| CENTER OF GRAVITY ABOVE BOTTOM OF KEEL - FEET |                           |                    |                   |                      |         |

**LIGHT CONDITION**

Boat complete, ready for service in every respect, but without ammunition, stores, fresh water, complement, fuel or any other items of consumable or variable load. Includes liquids in machinery and systems at operating levels.

|   |            |
|---|------------|
| DRAFT CORRESPONDING TO ABOVE DISPLACEMENT AT CENTER OF FLOTATION        | FEET       |
| TRANSVERSE METACENTER ABOVE _____ AT ABOVE MEAN DRAFT                   | FEET       |
| C.G. ABOVE _____  | FEET       |
| GM _____  | FEET       |
| MOMENT TO ALTER TRIM 1 INCH   | FT. POUNDS |
| C.B. OF BOAT ON EVEN KEEL AT ABOVE DRAFT FORWARD/AFT OF REFERENCE FRAME | FEET       |
| C.G. FORWARD/AFT OF REFERENCE FRAME                                     | FEET       |
| TRIMMING LEVER FORWARD/AFT  | FEET       |

TRIM =  $\frac{\text{DISP. T (pounds)} \times \text{TRIMMING LEVER (ft.)}}{\text{MOMENT TO ALTER TRIM 1 IN. (ft. pounds)}} = \frac{\text{_____}}{\text{_____}} = \text{_____}$  INCHES BY HEAD/STEM

DIFF. IN DRAFT BETWEEN L.C.F. AND MIDSHIPS =  $\frac{\text{TRIM} \times \text{CG OF WP AFT OF WP (ft.)}}{\text{L.B.P. (ft.)}} = \frac{\text{_____}}{\text{_____}} = \text{_____}$  FEET INCREASE/DECREASE

LIST =  $\frac{\text{HEELING MOMENT (ft. pounds)}}{.01745 \times \text{DISP. T (pounds)} \times \text{GM}} = \frac{\text{_____}}{\text{_____}} = \text{_____}$  DEGREES PORT/STARBOARD

|                                      |         |     |
|--------------------------------------|---------|-----|
| DRAFTS ABOVE _____ AT PERPENDICULARS | FORWARD | FT. |
|                                      | AFT     | FT. |
|                                      | MEAN    | FT. |

COMPUTING BY \_\_\_\_\_ COMPUTING CHECKED \_\_\_\_\_

**ESTIMATE OF WEIGHT FOR BOATS**  
**BOAT IN HOISTING CONDITION - PAGE 2**  
 NAVSHIPS 4816-2 (REV. 11-57)

U.S.S. \_\_\_\_\_

BUDGET BUREAU NO. 45-2281  
 REPORT-BUSHIPS-9291-A

PAGE 2 OF \_\_\_\_\_  
 DATE \_\_\_\_\_

| DESCRIPTION                                   | WEIGHT<br>(Pounds) | CENTER OF GRAVITY |         |                       |        |
|---|--------------------|-------------------|---------|-----------------------|--------|
|   |                    | ABOVE<br>BASE     | MOMENTS | REFERRED TO FRAME NO. |        |
|   |                    | FT                | INCHES  | AFT                   | INCHES |
| BOAT IN LIGHT CONDITION (Free Page 1)         |                    |                   |         |                       |        |
| AMMUNITION                                    |                    |                   |         |                       |        |
| STORES  |                    |                   |         |                       |        |
| POTABLE WATER                                 |                    |                   |         |                       |        |
| FUEL  |                    |                   |         |                       |        |
| CARGO   |                    |                   |         |                       |        |
| COMPLEMENT                                    |                    |                   |         |                       |        |
| SLINGS  |                    |                   |         |                       |        |
| <b>BOAT IN HOISTING CONDITION</b>             |                    |                   |         |                       |        |
| BASE ABOVE/BELOW BOTTOM OF KEEL - FEET        |                    |                   |         |                       |        |
| CENTER OF GRAVITY ABOVE BOTTOM OF KEEL - FEET |                    |                   |         |                       |        |

**HOISTING CONDITION**

This condition is defined  
 in the detail specifications.

|   |                         |    |        |
|---|-------------------------|----|--------|
| DRAFT CORRESPONDING TO ABOVE DISPLACEMENT AT CENTER OF FLOTATION  | FEET                    |    |        |
| TRANSVERSE METACENTER ABOVE _____ AT ABOVE MEAN DRAFT   | FEET                    |    |        |
| C. G. ABOVE _____   | FEET                    |    |        |
| GM NO CORRECTION FOR FREE SURFACE. FEET (CORRECTION = _____) GM CORRECTED FOR FREE SURFACE.   | FEET                    |    |        |
| MOMENT TO ALTER TRIM 1 INCH   | FT. POUNDS              |    |        |
| C. B. OF BOAT ON EVEN KEEL AT ABOVE DRAFT FORWARD/AFT OF REFERENCE FRAME  | FEET                    |    |        |
| C. G. FORWARD/AFT OF REFERENCE FRAME  | FEET                    |    |        |
| TRIMMING LEVER FORWARD/AFT  | FEET                    |    |        |
| TRIM = $\frac{\text{DISP'T (pounds)} \times \text{TRIMMING LEVER (ft.)}}{\text{MOMENT TO ALTER TRIM 1 IN. (ft. pounds)}}$ = _____         | INCHES BY HEAD/STERN    |    |        |
| DIFF. IN DRAFT BETWEEN L. C. F. AND MIDSHIPS = $\frac{\text{TRIM} \times \text{CG OF WP AFT OF WP (ft.)}}{\text{L. B. P. (ft.)}}$ = _____ | FEET INCREASE/DECREASE  |    |        |
| LIST = $\frac{\text{HEELING MOMENT (ft. pounds)}}{0.7854 \times \text{DISP'T (pounds)} \times \text{GM}}$ = _____                         | DEGREES PORT/STARBOARD  |    |        |
| DRAFTS ABOVE _____ AT PERPENDICULARS  | FORWARD                 | FT | INCHES |
|   | AFT                     | FT | INCHES |
|   | MEAN                    | FT | INCHES |
| COMPUTING BY _____  | COMPUTING CHECKED _____ |    |        |

**ESTIMATE OF WEIGHT FOR BOATS  
BOAT IN TRIAL CONDITION - PAGE 3  
NAVSHPIS 4816-2 (REV. 11-57)**

U.S.S. \_\_\_\_\_

PAGE 3 OF \_\_\_\_\_

BUDGET BUREAU 45-4281  
REPORT-BUSHPIS-9291-A

DATE \_\_\_\_\_

| DESCRIPTION   | WEIGHT<br>(Pounds) | MOMENTS       |               | CENTER OF GRAVITY       |                              |
|---|--------------------|---------------|---------------|-------------------------|------------------------------|
|   |                    | ABOVE<br>BASE | BELOW<br>BASE | FEED                    | REFERRED TO FRAME NO.<br>AFT |
| BOAT IN LIGHT CONDITION (From Page 1)   |                    |               |               |                         |                              |
| AMMUNITION  |                    |               |               |                         |                              |
| STORES  |                    |               |               |                         |                              |
| POTABLE WATER   |                    |               |               |                         |                              |
| FUEL  |                    |               |               |                         |                              |
| CARGO   |                    |               |               |                         |                              |
| COMPLEMENT  |                    |               |               |                         |                              |
| <b>BOAT IN TRIAL CONDITION</b>  |                    |               |               |                         |                              |
| BASE ABOVE/BELOW BOTTOM OF KEEL - FEET  |                    |               |               |                         |                              |
| CENTER OF GRAVITY ABOVE BOTTOM OF KEEL - FEET   |                    |               |               |                         |                              |
| <b>TRIAL CONDITION</b>  |                    |               |               |                         |                              |
| DRAFT CORRESPONDING TO ABOVE DISPLACEMENT AT CENTER OF FLOTATION  |                    |               |               |                         |                              |
| TRANSVERSE METACENT. ABOVE _____ AT ABOVE MEAN DRAFT  |                    |               |               |                         |                              |
| C.G. ABOVE _____  |                    |               |               |                         |                              |
| GM NO CORRECTION FOR FREE SURFACE. FEET (CORRECTION = $\frac{\text{feet} \times \text{GM}}{\text{feet}}$ )  |                    |               |               |                         |                              |
| MOMENT TO ALTER TRIM 1 INCH _____ FT. POUNDS  |                    |               |               |                         |                              |
| C.B. OF BOAT ON EVEN KEEL AT ABOVE DRAFT FORWARD/AFT OF REFERENCE FRAME   |                    |               |               |                         |                              |
| C.G. FORWARD/AFT OF REFERENCE FRAME   |                    |               |               |                         |                              |
| TRIMMING LEVER FORWARD/AFT  |                    |               |               |                         |                              |
| TRIM = $\frac{\text{DISP'T (pounds)} \times \text{TRIMMING LEVER (ft.)}}{\text{MOMENT TO ALTER TRIM 1 IN. (ft. pounds)}}$ = _____ INCHES BY HEAD/STERN        |                    |               |               |                         |                              |
| DIFF. IN DRAFT BETWEEN L.C.F. AND MIDSHIPS = $\frac{\text{TRIM} \times \text{CG OF SP. AFT OF MP (ft.)}}{\text{L.B.P. (ft.)}}$ = _____ FEET INCREASE/DECREASE |                    |               |               |                         |                              |
| LIST = $\frac{\text{HEELING MOMENT (ft. pounds)}}{.01745 \times \text{DISP'T (pounds)} \times \text{GM}}$ = _____ DEGREES PORT/STARBOARD                      |                    |               |               |                         |                              |
| DRAFTS ABOVE _____ AT PERPENDICULARS FORWARD _____ FT. INCHES   |                    |               |               |                         |                              |
| AFT _____ FT. INCHES  |                    |               |               |                         |                              |
| MEAN _____ FT. INCHES   |                    |               |               |                         |                              |
| COMPUTING BY _____  |                    |               |               | COMPUTING CHECKED _____ |                              |

This condition is defined in the detail specifications.

ESTIMATE OF WEIGHT FOR BOATS  
BOAT IN FULL LOAD CONDITION - PAGE 4  
NAVSHPIS 4816.2 (REV. 11-57)

U.S.S. \_\_\_\_\_

BUDGET BUREAU 45-928/  
REPORT-BUSHIPS-929-4

PAGE 4 OF \_\_\_\_\_  
DATE \_\_\_\_\_

| DESCRIPTION   | WEIGHT<br>(Pounds) | CENTER OF GRAVITY |         |                       |
|---|--------------------|-------------------|---------|-----------------------|
|   |                    | ABOVE<br>BASE     | MOMENTS | REFERRED TO FRAME NO. |
|   |                    | FEET              | FEET    | MOMENTS               |
| <b>BOAT IN LIGHT CONDITION (From Page 1)</b>  |                    |                   |         |                       |
| AMMUNITION  |                    |                   |         |                       |
| STORES  |                    |                   |         |                       |
| POTABLE WATER   |                    |                   |         |                       |
| FUEL  |                    |                   |         |                       |
| CARGO   |                    |                   |         |                       |
| COMPLEMENT  |                    |                   |         |                       |
| <b>BOAT IN FULL LOAD CONDITION</b>  |                    |                   |         |                       |
| BASE ABOVE/BELOW BOTTOM OF KEEL - FEET  |                    |                   |         |                       |
| CENTER OF GRAVITY ABOVE BOTTOM OF KEEL - FEET   |                    |                   |         |                       |
| <b>FULL LOAD CONDITION</b>  |                    |                   |         |                       |
| Boat complete, ready for service in every respect; officers and men and their effects; standard allowance plus mobilization supply of ammunition; full supply of consumable stores for period specified in the design characteristics; all equipment, spare parts, tools and maintenance supplies; potable water (full tanks); fuel (full tanks); full cargo, whether liquid or solid, plus passengers. |                    |                   |         |                       |
| DRAFT CORRESPONDING TO ABOVE DISPLACEMENT AT CENTER OF FLOTATION  |                    |                   |         |                       |
| TRANSVERSE METACENTER ABOVE _____ AT ABOVE MEAN DRAFT   |                    |                   |         |                       |
| C.G. ABOVE _____  |                    |                   |         |                       |
| GM NO CORRECTION FOR FREE SURFACE. FEET (CORRECTION = $\frac{GM}{\text{feet}}$ ). GM CORRECTED FOR FREE SURFACE.  |                    |                   |         |                       |
| MOMENT TO ALTER TRIM 1 INCH   |                    |                   |         |                       |
| C.B. OF BOAT ON EVEN KEEL AT ABOVE DRAFT FORWARD/AFT OF REFERENCE FRAME   |                    |                   |         |                       |
| C.G. FORWARD/AFT OF REFERENCE FRAME   |                    |                   |         |                       |
| TRIMMING LEVER FORWARD/AFT  |                    |                   |         |                       |
| TRIM = $\frac{\text{DISP'T (pounds)} \times \text{TRIMMING LEVER (ft.)}}{\text{MOMENT TO ALTER TRIM 1 IN. (ft. pounds)}}$ = _____   |                    |                   |         |                       |
| DIFF. IN DRAFT BETWEEN L.C.F. AND MIDSHIPS = $\frac{\text{TRIM} \times \text{CG OF WP AFT OF WP (ft.)}}{\text{L.B.P. (ft.)}}$ = _____   |                    |                   |         |                       |
| LIST = $\frac{\text{HEELING MOMENT (ft. pounds)}}{.01745 \times \text{DISP'T (pounds)} \times \text{GM}}$ = _____   |                    |                   |         |                       |
| DRAFTS ABOVE _____ AT PERPENDICULARS  |                    |                   |         |                       |
| FORWARD   |                    |                   |         |                       |
| AFT   |                    |                   |         |                       |
| MEAN  |                    |                   |         |                       |
| COMPUTING BY _____  |                    |                   |         |                       |
| CHECKED BY _____  |                    |                   |         |                       |
| COMPUTING CHECKED _____   |                    |                   |         |                       |

H22213