

AD-A047 507

VEHICLE SYSTEMS DEVELOPMENT CORP UPLAND CA
HELICOPTER GROUND MOBILITY SYSTEM (HGMS) CONCEPT FORMULATION AN--ETC(U)
SEP 77 R W FORSYTH, J P FORSYTH

F/G 1/3

DAAJ02-76-C-0037

UNCLASSIFIED

USAAMRDL-TR-77-35

NL

1 OF 1
AD
A047507



END
DATE
FILMED
1 -78
DDC

USAAMRDL-TR -77-35

12
b.s



**HELICOPTER GROUND MOBILITY SYSTEM (HGMS) CONCEPT
FORMULATION AND SELECTION**

Vehicle Systems Development Corporation
1251 West 9th Street
Upland, Calif. 91786

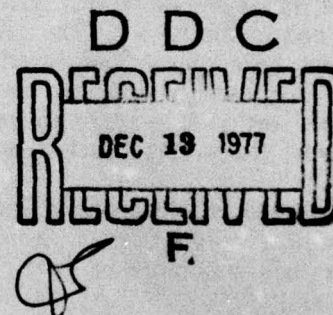

September 1977

Final Report for Period 29 June 1976 - 20 June 1977

Approved for public release;
distribution unlimited.

Prepared for
APPLIED TECHNOLOGY LABORATORY
RESEARCH AND TECHNOLOGY LABORATORIES (AVRADCOM)
Fort Eustis, Va. 23604

AD A 0 4 7 5 0 7

DDC FILE COPY

EUSTIS DIRECTORATE POSITION STATEMENT*

This report was prepared by the Vehicle Systems Development Corporation under Contract DAAJ02-76-C-0037. It describes the approach, the trade-offs, and the selected configuration of a helicopter ground mobility system that could be used to move both wheeled and skid-equipped light helicopters across rough terrain for purposes of concealment in natural foliage or for maintenance purposes. The selected configuration can also be used to tow medium helicopters and all Army fixed-wing aircraft on hard ramp areas. The report and associated layout drawings, along with a hardware procurement specification, were the objectives of a Ground Mobility System concept formulation and configuration selection required by the contract.

Finite Ground Mobility System performance and mobility requirements were described in the Statement of Work. Many potential approaches were reviewed and screened as described in the report. The selected HGMS is an innovative application of the concept of using helicopter weight to achieve the required traction in soft, rough terrain and retain a lightweight and low volume in the HGMS for air mobility. The depth of analysis was good, and the selected concept yields a high degree of confidence of achieving the required performance.

The selected HGMS concept described in the report and the associated specification is to be fabricated into concept verification that can be tested on the applicable helicopters under field conditions to verify the performance.

This report has been reviewed by the appropriate technical personnel of this Directorate, who concur with the conclusions contained herein. The U.S. Army Project Engineer for this effort was Mr. R. L. Campbell, Sr. of the Military Operations Technology Division.

*On 1 September 1977, after this report had been prepared, the name of this organization was changed from Eustis Directorate, U.S. Army Air Mobility Research and Development Laboratory to Applied Technology Laboratory, U.S. Army Research and Technology Laboratories (AVRADCOM).

DISCLAIMERS

The findings in this report are not to be construed as an official Department of the Army position unless so designated by other authorized documents.

When Government drawings, specifications, or other data are used for any purpose other than in connection with a definitely related Government procurement operation, the United States Government thereby incurs no responsibility nor any obligation whatsoever; and the fact that the Government may have formulated, furnished, or in any way supplied the said drawings, specifications, or other data is not to be regarded by implication or otherwise as in any manner licensing the holder or any other person or corporation, or conveying any rights or permission, to manufacture, use, or sell any patented invention that may in any way be related thereto.

Trade names cited in this report do not constitute an official endorsement or approval of the use of such commercial hardware or software.

DISPOSITION INSTRUCTIONS

Destroy this report when no longer needed. Do not return it to the originator.

Unclassified

SECURITY CLASSIFICATION OF THIS PAGE(When Data Entered)

20. Abstract (Cont d.)

selection; Task III - HGMS Design Layouts; and Task IV - Skid Helicopter Adapter. The first task resulted in the definition of some 30 ground mobility system concepts, including wheeled and tracked, frame-type transporters, auxiliary wheel systems, all-wheel-drive prime movers, and two-element, articulated mover systems designed for load transfer from the helicopter. In Task II, the contractor developed evaluation criteria and conducted a preliminary analysis of the suitability of the various concepts for the mission of providing local ground mobility for the AAH and UTTAS helicopters in unimproved terrain. The task was concluded with a review of the results of the contractor's analysis by USAAMRDL and other cognizant Army agencies and a selection of one concept for further development and prototype design.

The third task involved the preparation of prototype design layouts of the selected concept, a four-wheeled, two-element, articulated prime mover, with provisions for offloading the tail wheel of the helicopter for weight transfer, and controls for a walking operator. With tractive effort provided by this, the flotation required for the helicopter is achieved by temporarily attaching tracks on the main landing gear of the helicopter. Additionally, under Task III, the contractor prepared the system specification for the HGMS.

The program effort was concluded with Task IV, which involved the development of a concept design and preliminary layout drawings for the adapter unit enabling use of the HGMS with skid-equipped helicopters.

The program described in this report clearly demonstrates the technical, operational, and economic feasibility of a helicopter ground movement system to mobilize the AAH and UTTAS helicopters, and, with an adapter, skid-equipped helicopters for dispersal and concealment on the ground in unprepared landing areas.

Unclassified

SECURITY CLASSIFICATION OF THIS PAGE(When Data Entered)

PREFACE

This investigation was conducted for the Eustis Directorate, U.S. Army Air Mobility Research and Development Laboratory (USAAMRDL), Fort Eustis, Virginia, under Contract DAAJ02-76-C-0037.

USAAMRDL technical direction was provided by Mr. Robert L. Campbell, Sr.

The Vehicle Systems Development Corporation (VSDC) personnel involved in performance of the subject concept formulation and feasibility investigation were: Robert W. Forsyth, president and chief engineer; Nathan N. Shiovitz senior design engineer; John P. Forsyth, vice president and engineering analyst; and Dennis F. Otto, senior designer.

ACCESSION for	
NTIS	White Section <input checked="" type="checkbox"/>
DDC	Buff Section <input type="checkbox"/>
(UNANNOUNCED)	<input type="checkbox"/>
CLASSIFICATION	
BY	
DISTRIBUTION/AVAILABILITY CODES	
Dist.	/ or SPECIAL
A	

TABLE OF CONTENTS

	<u>Page</u>
LIST OF ILLUSTRATIONS.	6
LIST OF TABLES	7
1.0 INTRODUCTION.	8
1.1 Background	8
1.2 Mission Definition	12
1.3 Program History and Organization	14
2.0 CONCEPT DESCRIPTIONS.	16
2.1 General Considerations	16
2.2 HGMS Design Concepts	17
3.0 HGMS CONCEPT SCREENING AND EVALUATION	41
3.1 Preliminary Screening.	41
3.2 Matrix Analysis.	44
3.3 Comparison Profile Evaluation.	49
3.4 Concept Selection.	61
4.0 PROTOTYPE DESIGN.	64
4.1 Physical and Performance Characteristics	64
4.2 Skid-Equipped Helicopter Adapter	75
5.0 CONCLUSIONS AND RECOMMENDATIONS	81
REFERENCES	84
BIBLIOGRAPHY	85
APPENDIX A - VCI Procedure, Motion Resistance, and Power Requirements.	86

ENCLOSURE PAGE BLANK-NOT FILMED

LIST OF ILLUSTRATIONS

<u>Figure</u>		<u>Page</u>
1.	Concept 1 - Auxiliary Wheel Frame	19
2.	Concept 2 - Extendable Twin-Boom Carrier	20
3.	Concept 3 - Fixed Frame Transporter	21
4.	Concept 4 - Tracked Transporter Frame	22
5.	Concept 5 - Tracked Straddle-Lift Carrier	24
6.	Concept 6 - Tandem Cradle-Lift Carriers	25
7.	Concept 7 - Expanding Frame Transporter	26
8.	Concept 8 - Sling Band Transporter	27
9.	Concept 9A - Articulated Load-Transfer Mover	28
10.	Concept 9B - Articulated Load-Transfer Mover	30
11.	Concept 10 - Pivoting Frame Load-Transfer Mover	31
12.	Concept 11 - Two-Element Load-Transfer Mover	32
13.	Concept 12 - Twin Auxiliary-Wheel Mover	34
14.	Concept 13 - All-Wheel-Drive Prime Mover	35
15.	Concept 14 - Wheel Propulsion System	38
16.	Concept 15 - Air-Cushion Mover System	39
17.	HGMS Concepts Matrix Analysis	45
18.	Concept 9 - Comparison Profile Chart	50
19.	Concept 10 - Comparison Profile Chart	51
20.	Concept 11 - Comparison Profile Chart	52
21.	Concept 13 - Comparison Profile Chart	53
22.	Concept 14 - Comparison Profile Chart	54
23.	TEAMS Concept	63

LIST OF ILLUSTRATIONS (Cont'd.)

<u>Figure</u>		<u>Page</u>
24.	General Arrangement - Helicopter Ground Mobility System (HGMS)	65
25.	Operating Controls - Helicopter Ground Mobility System (HGMS)	71
26.	Flotation Track Installation - Helicopter Ground Mobility System (HGMS).	73
27.	Skid-Equipped Helicopter Adapter (HGMS).	77

LIST OF TABLES

<u>Table</u>		<u>Page</u>
1.	HGMS CONCEPT VEHICLE CONE INDEX (VCI ₁)	46
2.	ESTIMATED LIFE-CYCLE UNIT COSTS	59
3.	ENGINE CANDIDATES.	67
A-1	HGMS CONCEPT VEHICLE CONE INDEX (VCI ₁)	87

1.

INTRODUCTION

1.1 BACKGROUND

Skid-equipped helicopters, since their introduction into general, civil, and military use, have presented problems with respect to local, on-the-ground movement for servicing and maintenance. Where these helicopters are based on improved operational sites, ground movement, with the lift system static, has been routinely accomplished by the use of a combination of castered or wheeled landing pads, towbars, and lightweight prime movers or tow tugs, or skid-mounted, ground-handling wheels, adapters, and tugs. Often, in military operations, however, skid-equipped helicopters must operate from unimproved landing areas where the problem of local ground movement is magnified and the typical landing pad or ground-handling wheel arrangement will not provide the required levels of mobility.

The incorporation of wheeled landing gear on civil and military helicopters eliminates the need for much of the support equipment associated with the ground handling of skid-equipped helicopters on paved surfaces, but in operations from unprepared landing areas the situation is not much improved over that experienced with the typical skid-equipped helicopter.

In reviewing tactical considerations in the employment of utility and attack helicopters in possible European operational areas, the 7th Army, in the early 1970's, concluded that a means would have to be developed to move skid-equipped helicopters into concealed positions in forward laager areas to reduce the possibility of detection and, in turn, their vulnerability to hostile action while they were being serviced and rearmed. This ultimately led to the approval and publication of a Required Operational Capability (ROC)

document in June 1973, defining a requirement for a ground movement or mobility system for skid-equipped helicopters.

Development and test activity directed toward satisfaction of this requirement involved the Army Aviation Systems Command¹, the Land Warfare Laboratory², and the U.S. Army MASSTER at Fort Hood, Texas³. Their mutual efforts resulted in the fabrication and evaluation of several candidate helicopter ground mobility systems. These included: A self-propelled, rough-terrain, ground-handling system mounted on tracks; an air-cushion platform with ramps and a winch; UH-1 ground-handling wheels modified for use on the OH-58; powered UH-1 ground-handling wheels; a powered helicopter transporter with tracks and roller-type skid ramps; so-called "field wheels", wheels mounted on axle assemblies attached to the helicopter skids and carrying high-flotation tires; and various configurations or arrangements of UH-1 ground-handling wheels and towbars.

MASSTER was assigned the task of testing and evaluating these systems in terrain conditions approximating those which were characteristic of unprepared laager areas. The powered ground-

¹HELICOPTER MOVEMENT ON UNIMPROVED TERRAIN, USAEWES Technical Report M-74-1, U.S. Army Aviation Systems Command/U.S. Army Engineer Waterways Experiment Station, Vicksburg, Mississippi, January 1974.

²EXPEDIENT MEANS FOR MOVING HELICOPTERS, USALWL Technical Report 74-75, U.S. Army Land Warfare Laboratory, Aberdeen Proving Ground, Maryland, April 1974.

³HELICOPTER GROUND MOVEMENT SYSTEMS TEST, MASSTER Test Report FM 161, Headquarters, Modern Army Selected System Test, Evaluation, and Review, Fort Hood, Texas, March 1975.

handling wheels and the rough-terrain ground-handling system were dropped from the MASSTER test program early on because of mechanical deficiencies that developed in the initial engineering shakedown. The remaining systems were evaluated with respect to mobility, maneuverability, power, speed, signature, transportability, helicopter attach/detach times, and tow vehicle requirements.

The air-cushion platform and the helicopter transporter both suffered from control and maneuvering problems, and their size and weight were such as to make their transportability, on the ground or by aircraft, questionable. Because of these considerations, and such other factors as the signature of the air-cushion platform and the poor ratio of availability to downtime for the helicopter transporter, both designs were found unsatisfactory. Use of the UH-1 ground-handling wheels on the OH-58 was found, generally, to be an acceptable concept; however, the impact and torsional loads transmitted to the helicopter's skid landing gear while it was being towed over irregular terrain indicated this approach could, ultimately, prove to be damaging to the skid structure.

The field wheels, both the four-wheel and two-wheel versions, demonstrated satisfactory performance from a mobility standpoint. But a drawback of the four-wheel version was a weight of approximately 1500 pounds. It was also found that the equipment presented some difficulties in maneuvering, particularly with regard to changing the direction of travel. The two-wheel version of the field wheels resolved these problems and was found to be an acceptable means of mobilizing the UH-1 helicopter hulks used in the MASSTER tests. The extended UH-1 ground-handling wheels were also found to be generally satisfactory, providing additional ground clearance and improved flotation. As with the UH-1 ground-handling wheels used on

the OH-58, and as with the field-wheel devices, however, no means were available to evaluate the magnitude of the torsional and impact loads imposed on helicopter structure during negotiation of the MASSTER test course.

While, as noted, some of the systems were found satisfactory, the overall conclusion resulting from MASSTER's test and evaluation was that none of the concepts warranted further development. Consequently, no further activity took place until the advent of the developmental programs for the Army's new attack helicopter (the AAH) and utility helicopter (UTTAS). Although all of the candidate designs were to incorporate wheeled landing gear, the constraints imposed by aerodynamic and performance considerations dictated the use of relatively high-pressure, small footprint tires on the main landing gear of the helicopters. While this would provide a good capability for local ground movement at prepared operational sites, the initial indications were that the wheeled running gear would not prove satisfactory for local ground movement in unprepared laager areas.

This situation resulted in a decision in mid-1975 by the Eustis Directorate, U.S. Army Air Mobility Research and Development Laboratory (USAAMRDL), to initiate a program to develop a Helicopter Ground Mobility System (HGMS) for the wheeled AAH and UTTAS helicopters to provide a capability for local ground movement in rough terrain. A secondary objective of the program was to determine, through additional design and analysis, whether the wheeled helicopter HGMS could be adapted for skid-equipped helicopters. This report summarizes the results of the first phase of the USAAMRDL development program - the HGMS concept feasibility investigation, selection and design layout.

1.2 MISSION DEFINITION

In possible future mid-intensity conflicts in Europe, the U.S. Army plans to employ utility and attack helicopters in close support of ground operations. These helicopters, including the UTTAS and AAH (now designated the UH-60A and YAH-64), will obviously be vulnerable to detection and hostile action when they are on the ground between sorties for refueling, rearming, and servicing. To reduce their vulnerability, the Army requires a capability to mobilize the helicopters with their lift systems static and to locally move them into and out of positions affording natural concealment. In its most fundamental aspect, achieving this capability calls for a Helicopter Ground Mobility System (HGMS) that will provide tractive effort, flotation, and obstacle-crossing ability in adverse terrain employing its own power source or a power source on the helicopter. A secondary HGMS objective is the movement of applicable helicopters to sites within the laager area for maintenance purposes. An additional desired HGMS capability is the use of the selected device for loading or unloading of the affected helicopters onto or off transport aircraft such as the C-130, C-141, and C-5A, preferably without extensive HGMS reconfiguration from its field operating configuration.

The basic mission requirement for the HGMS is to mobilize Army helicopters for local ground movement, making use of an integral power source or a helicopter power source to develop tractive effort through a high-flotation, ground-engaging means, thereby enabling the negotiation of adverse terrain. Defining the HGMS mission in greater detail, the system must be capable of accommodating helicopters with weights up to 16,000 pounds and must be designed so as to permit a change in configuration, if required, in no more than 3 minutes to adapt it to either the AAH or UTTAS helicopters. The HGMS, additionally, must be air transportable by the UTTAS helicopter, either as an

internal or sling load, to enable its movement with aviation units to which it is organic, or to which it is attached. If disassembly of the HGMS is required for air transport, then the disassembly and reassembly operations, with two mechanics, shall not require more than 1 hour each to complete.

A USAAMRDL operational scenario for the HGMS was generated using various Training and Doctrine Command (TRADOC) documents. The assumptions are: (1) the helicopters in the laager area are dispersed into a treeline adjacent to the landing/takeoff site, are 30 meters (98.4 feet) apart, and have been fueled, armed, and preflight inspected; and (2) the laager area is an unprepared site with no surface treatment and having rough terrain between the concealment point and takeoff site. Upon mission alert, one HGMS would be required to extract up to five helicopters, moving each 60 feet to clear the treeline. Using maximum task times of 3 minutes to attach or detach the HGMS to or from a helicopter and a rough terrain helicopter movement speed of 1 mile per hour (1.4 feet/second), with "unloaded" HGMS movements of 100 feet between helicopters, a time line analysis determined that 39 minutes would be required to move five helicopters to takeoff positions, assuming no HGMS reconfiguration is required if one of the helicopters is an escort gunship. This was felt to be a maximum allowable time and should be reduced if technically possible.

The definition of rough, unprepared terrain stemmed from an earlier Army Joint Working Group decision in conjunction with a previous Required Operational Capability (ROC) for a skid-equipped helicopter ground movement system. USAAMRDL discussions with Waterways Experiment Station personnel resulted in citing soil firmness in terms of Cone Index (CI) in lieu of California Bearing Ratio (CBR) to better define subsurface conditions. Thus a CBR of 1.0 was converted to a CI

of 50 on a shallow (3 percent) slope, with graduations to a harder CBR of 2.5 (CI of 125) on the maximum (15 percent) slope. The obstacle, or ditch, depth was set at 6 inches, with spacing between obstacles set at 10 feet. It should be noted that the original design requirements for the AAH and UTTAS aircraft prototypes called for inherent mobility, or towability, in a CBR as low as 2.5. The HGMS will, therefore, extend the ground mobility of those wheeled helicopter models into the much less firm terrain to be encountered in the unprepared operational sites in a combat area.

Additional requirements imposed by the overall or basic HGMS mission description include provisions for precise directional, speed, and braking control, and a weight distribution on the system with a helicopter payload that will assure lateral and longitudinal stability on irregular terrain, grades, and slopes.

1.3 PROGRAM HISTORY AND ORGANIZATION

As noted previously, USAAMRDL made a decision in mid-1975 to initiate a program to develop a Helicopter Ground Mobility System (HGMS) to provide local ground mobility for the wheeled UTTAS and AAH helicopters, with the secondary objective of determining whether the system could be adapted for use on skid-equipped helicopters. The first phase of the program, the concept design and feasibility investigation which is the subject of this report, was contracted for in July 1976. Initially the contractor, Vehicle Systems Development Corporation (VSDC), was tasked to develop HGMS design concepts which could be used, interchangeably, on both of the two competitive designs for the UTTAS helicopter (the YUH-60A and the YUH-61A), and for the AAH helicopter (the YAH-63A and the YAH-64A). This involved incorporating provisions in all candidate HGMS concepts for rapid configuration changes to adapt the systems to use on nosewheel and tailwheel landing gear layouts. However,

with the study approximately two-thirds complete, in December 1976, the Army announced its selection of the UH-60A (formerly the YUH-60A) as the winner of the UTTAS competition, and shortly thereafter selected the YAH-64 as the winner of the AAH competition. This action on the part of the Army took place shortly after USAAMRDL, and representatives of other Army agencies, in conjunction with VSDC had reviewed the candidate HGMS concepts and had selected the most promising HGMS design.

While the selection of two helicopter models having a tail-wheel landing gear layout in common ultimately simplified the HGMS design task, the HGMS concept configurations developed up to the time of the announcement of the winners of the AAH and UTTAS competition had to be modified to delete provisions for the accommodation of the unsuccessful helicopter candidates with their nosewheel landing gear layouts. Additionally, as the design analysis and investigation progressed, a determination was made that the basic HGMS could be adapted to use on the Army's current inventory, skid-equipped helicopters and the contract was modified to expand the scope of work to include the concept design of a skid-equipped helicopter adapter.

The HGMS concept design and feasibility investigation was organized as a three-step effort, with the first task covering concept formulation, including the development of preliminary concepts and a definition of criteria, followed by a concept evaluation and selection task, and concluding with a task devoted to preparation of design layouts for the selected HGMS concept and the development of a specification defining the system. USAAMRDL will use the HGMS engineering data package as the basis for procurement of HGMS prototypes, which will be the second phase in the overall development program.

2.

CONCEPT DESCRIPTIONS

2.1 GENERAL CONSIDERATIONS

Basically, the approach used in developing the conceptual HGMS designs involved investigation of specific mission requirements and the expected operating environments, and an analysis of equipment transportability parameters. This relatively brief activity was followed by the preliminary conception of a number of possible HGMS configurations and the definition of system criteria and constraints. This activity resulted in the development of some 30 individual HGMS candidate designs, including the alternate configurations for several of the basic designs.

A procedure was then developed to accomplish a preliminary screening of the HGMS candidates and to select the most promising concepts for further development. Essentially a three-step operation, this involved a first examination of the candidate systems to eliminate those with obvious technical, operational, or cost shortcomings, followed by a more detailed evaluation using a matrix of parameters such as weight, payload, and ground pressure. The candidate systems surviving these two screening steps were then subjected to additional design efforts to achieve a more complete definition of functional, physical, and cost characteristics so that comparison profile charts could be constructed for each and used as a basis for final selection action.

Of the criteria applied to the HGMS candidates, perhaps the most critical related to mobility. With respect to the requirement for the systems to successfully negotiate a 3 percent grade on soils with a Rating Cone Index (RCI) or Cone Index (CI) as low as 50, they must possess a Vehicle Cone Index (VCI) sufficiently below the 50 index figure to assure gradeability in self-propelled designs and to assure a low enough value for towed

motion resistance in towed designs to enable movement by the types of vehicles (prime movers) that could be expected to be available in forward laager areas. Also, in self-propelled HGMS designs, the systems must incorporate power plants and drive systems capable of producing the horsepower and torque needed, at maximum gross helicopter weights, to overcome the motion and grade resistance typically encountered in the specified soil conditions. Basically, 20 to 30 horsepower was considered adequate to provide sufficient reserves to achieve both a 1 mph speed on level ground in soil with a CI of 50 and a 3 mph speed on level ground in soil with a CI of 125. With auxiliary high-flotation devices attached to the helicopter main landing gear, or with auxiliary wheels with high-flotation tires, a maximum tractive effort of approximately 3,500 pounds was considered adequate to overcome the worst-case combinations of grade and motion resistance which are anticipated.

2.2 HGMS DESIGN CONCEPTS

As set forth in the Statement of Work of Contract DAAJ02-76-C-0037, the subject concept design and feasibility analysis contract, the HGMS candidate designs developed in the concept formulation phase included self-propelled and towed versions, designs incorporating the use of high-flotation tires and tracks, a design for a ground propulsion system integral to the helicopter, self-propelled versions of the HGMS utilizing power sources integral to the helicopter, and various advanced types of power plants integral to the HGMS. The following pages contain illustrations and descriptive material on each of the HGMS candidate designs which were investigated. In several instances, the concepts which are presented are representative of a family of designs, similar but varying in one or more configurational details.

For example, while only one track-laying, platform-type carrier is shown, it is representative of three different types. And the one wheeled, articulated, nosewheel/tailwheel prime mover is representative of 12 different types. In total, the contractor, VSDC, developed and investigated some 30 individual HGMS designs. Supporting technical data was generated for each design so that the engineering team conducting the program could make comparisons of the operational potential of each HGMS.

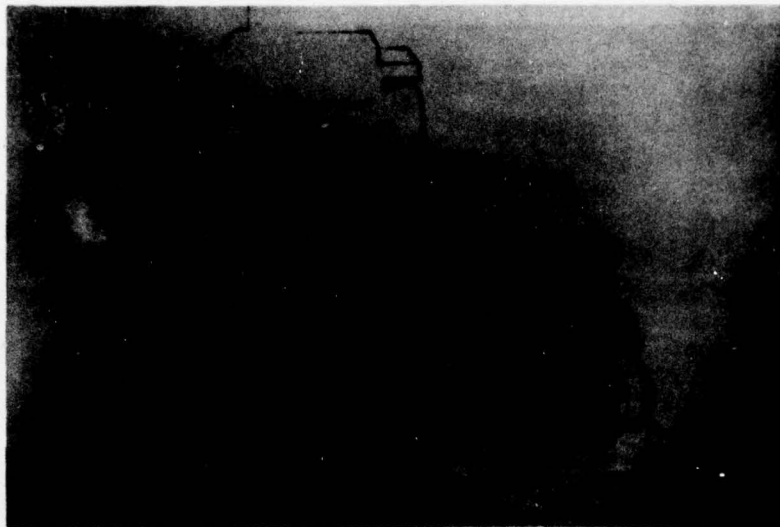

Figure 1. Concept 1 - Auxiliary Wheel Frame

Of U-shaped planform as shown in Figure 1, HGMS Concept 1 includes two high-flotation tires which offload the helicopter landing gear by approximately 60 percent. In addition to weight transfer, this concept employs a split drive from the M561, 1-1/4-ton prime mover to power the flotation wheels. Auxiliary, cuff-type flotation wheels are also fitted to the trailing tail wheel of the helicopter.

Concept 1 would be applicable to the Sikorsky UH-60A UTTAS and Hughes YAH-64 AAH helicopters. While the U-shaped frame could accommodate other payloads, its use would be limited to the leading element of the M561 1-1/4-ton truck if the benefits of powering the flotation wheels are to be gained.



Figure 2. Concept 2 - Extendable Twin-Boom Carrier

A twin, extendable boom layout, Concept 2, was configured to move the YAH-63 and YAH-64 AAH as well as the YUH-60A and YUH-61A UTTAS candidates. A VH4D, 30 hp Teledyne Wisconsin engine coupled to a pair of Commercial Shearing hydraulic pumps and motors completes the drive system. Hydraulic power is also employed for yaw-type articulated steering and boom extension and retraction.

The helicopter nose/tail and main landing gear are carried on wheel pads that are an integral element of the assembly. The wheel pads are lowered to ground level to facilitate loading by means of jacks. As can be seen in Figure 2, the Concept 2 HGMS can accommodate a wide range of helicopter wheelbase and main landing gear tread arrangements.

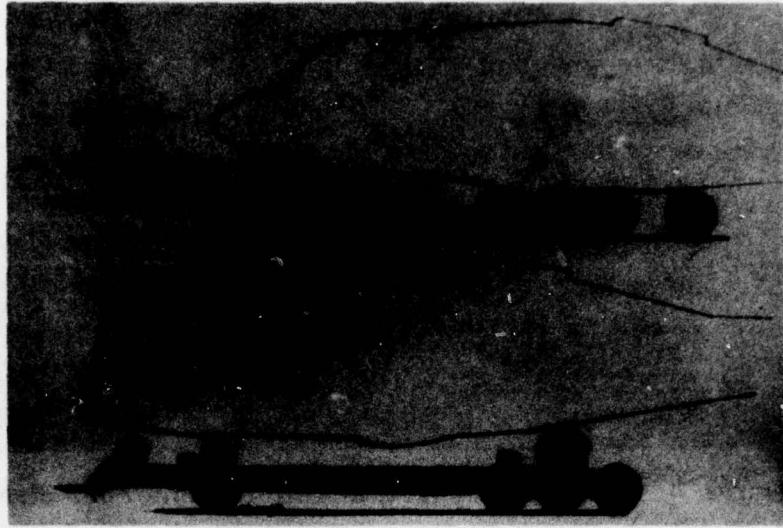

Figure 3. Concept 3 - Fixed Frame Transporter

A relatively simple towed carrier, this design was configured for moving the YAH-63 and YUH-61A helicopters with tricycle landing gear layouts.

For loading, the trailing-arm/walking-beam suspension elements are unlocked and the treadways lowered to ground level to form ramps for the helicopter landing gear. An electric winch using the 24-volt prime mover electrical system is then employed to winch the helicopter on the carrier. Jacks on the frame are then employed to raise the carrier to the travel position, at which time the suspension locks are engaged. Helicopter unloading is the reverse of the loading process.

Suitable prime movers include the M561 1-1/4-ton truck, the M880 series 1-1/4-ton truck, and the M37 3/4-ton truck.

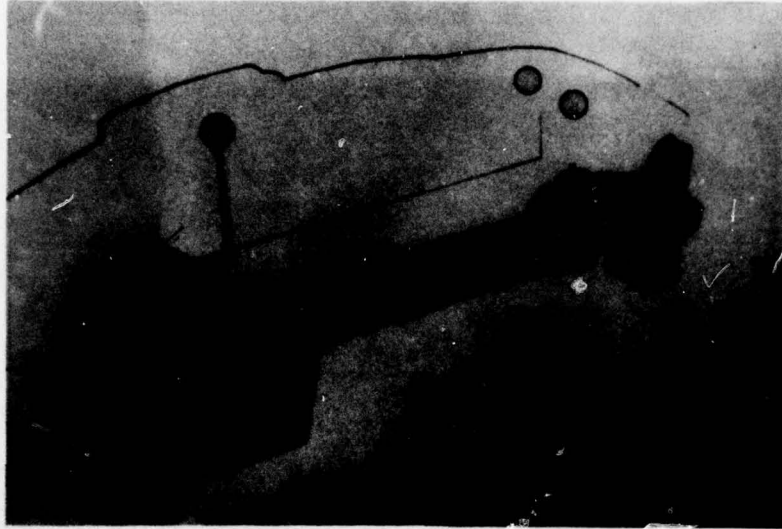

Figure 4. Concept 4 - Tracked Transporter Frame

A track-laying configuration with differential steering, Concept 4 utilizes air motors and helicopter bleed air for propulsion. Control of the mover on the ground is accomplished by the helicopter pilot from his flight station with the aid of an auxiliary joystick for speed and direction. A Briggs and Stratton engine with a generator/storage battery unit is fitted to the carrier for the operation of the winch and any local ground movement (spotting) without the helicopter payload. The small power unit is also utilized to raise and lower the carrier.

While Concept 4 could be configured to accommodate both conventional and tricycle-gear layouts, as a practical consideration, preliminary design effort was limited to tricycle-gear type designs. It is representative of several tracked carrier designs.

An additional possibility with Concept 4 is the opportunity for incorporating a wireless, hand-held remote controller in the helicopter. The controller would provide for HGMS engine starting, speed, steering, forward and reverse controls, and engine shutdown.

With this concept, the helicopter could takeoff and land directly on the HGMS. This feature, in combination with the remote controller in the helicopter, would permit an unmanned HGMS to be "called" from a secure area by the hovering helicopter crew. On takeoff, the helicopter crew would command the return of the HGMS to a tree line or other secure area.

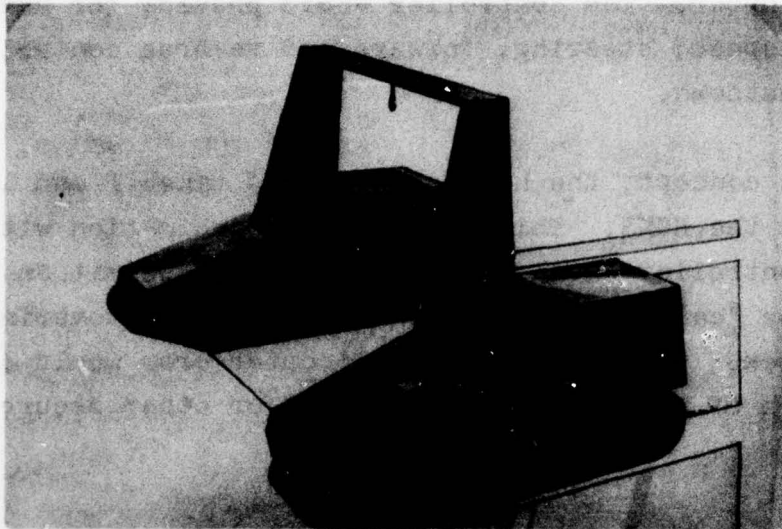

Figure 5. Concept 5 - Tracked Straddle-Lift Carrier

A full-tracked, straddle-lift mover, Concept 5 is capable of moving all of the UTTAS and AAH candidates as well as AH-1, UH-1, and OH-58A skid-type helicopters.

In addition to the HGMS mission, Concept 5 could be utilized for damaged or disabled helicopter recovery and transport. Endless band Military Standard (T125) tracks, engine (M151), transmission (M151), and developmental Military Standard (Bowen) cross-drive steer unit complete the layout.

Lateral positioning and restricted fore and aft movement of the helicopter is accomplished by means of secondary retention straps.



Figure 6. Concept 6 - Tandem Cradle-Lift Carriers

This HGMS design concept consists of two cradle-lift elements with walking beams and tandem low-profile Goodyear Terra-Tires (23 x 8.5-12).

The cradle assemblies are configured for attachment to the helicopter hard (jack) points and incorporate a spreader device to accommodate variations in helicopter fuselage widths. The lead cradle assembly is part of a two-wheel (wagon steer) power element that incorporates a Kohler K5825 23 hp engine, Vickers hydraulic pump/motor, and Dana Spicer drive axle with AUSCO disc brakes for differential steering.

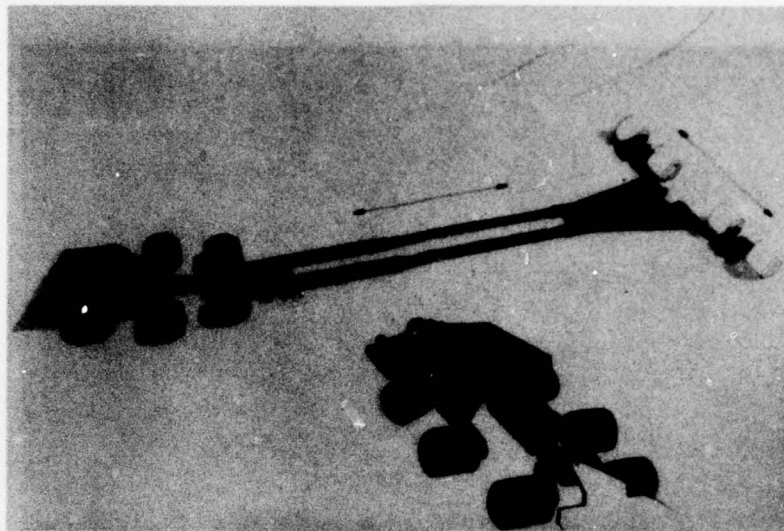

Figure 7. Concept 7 - Expanding Frame Transporter

This HGMS concept is capable of transporting all of the AAH/UTTAS helicopter candidates by means of an extendable frame for variations in landing gear wheelbase and tread. The wheelbase requirements of the conventional-gear (tail wheel) AAH and UTTAS candidates, however, would make the approach marginally acceptable. For example, the breakover angle of the frame in the fully extended configuration would preclude operation in undulating terrain, and even a modest obstacle or ditch could not be negotiated with any degree of confidence.

A four-wheel, all-wheel-drive power element with Ackermann-type steering is employed as the integral prime mover. A two-cylinder Onan CCKB (vehicle) engine in combination with a Char-Lynn (Eaton) pump and motors constitute the power train. When operated separately from the carrier frame assembly, the lead or power element with its elevatable fifth wheel can be adapted for ordnance loading, helicopter jacking, and forklift tasks.

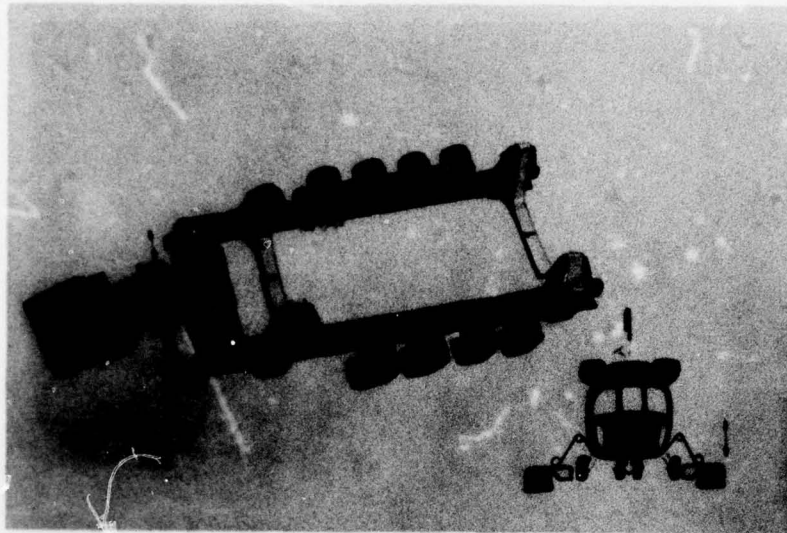

Figure 8. Concept 8 - Sling Band Transporter

This self-powered, sling-type mover is designed with two "belly" bands for lifting helicopters of different configuration. Tension (lift) in the bands is obtained by means of powered rollers. The roller mountings are capable of being positioned fore and aft on the frame rails to accommodate variations in helicopter layout.

The lead or power element is an integral part of this HGMS design and incorporates an articulation joint (which operates in roll and yaw). A single, double-acting ram is employed for the yaw steering function. An AVCO Lycoming W-44D (diesel) engine and Abex-Denison vane-type pump and motor combination are utilized for propulsion, power steering, sling tensioning, and operation of winch. The latter two functions, sling tensioning and winching, could also be accomplished with electric motors.

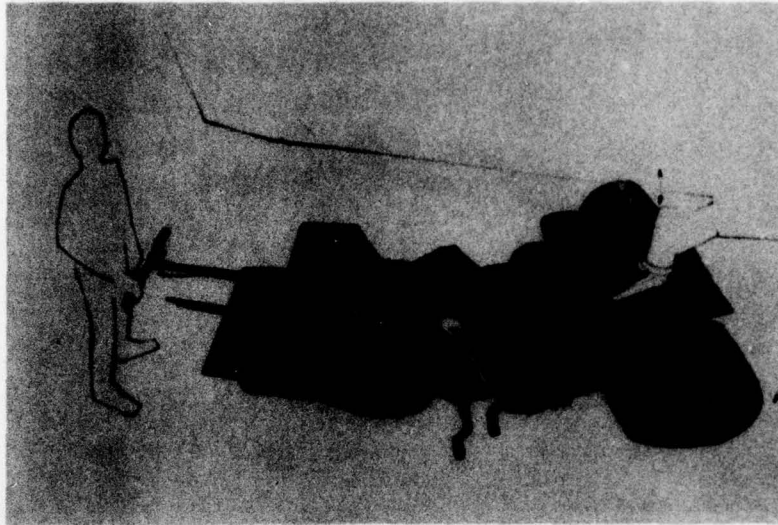

Figure 9. Concept 9A - Articulated Load-Transfer Mover

This self-propelled HGMS design is directed at utilizing helicopter weight to meet the tractive effort requirement to move a 15,000 - 18,000 pound payload. The configuration is based on the transfer of helicopter weight from the nose or tail wheel to the mover.

With this design, a wraparound, high-flotation track is secured to each helicopter main landing gear wheel assembly. The additional contact area of the track facilitates the movement of the helicopter over soft soil, and provides for a significant reduction in bulldozing resistance with an attendant reduction in drawbar pull for a given soil condition.

The flotation wheels and tires are mounted on trailing arms which are used to raise and lower the helicopter wheel carrier. An interesting feature of the concept is the dual-function crank and shift mechanism. In actual operation, the HGMS is

positioned at either the helicopter nose gear or tail wheel, the three-position mechanical shift lever is then moved to the "raise/lower" detent, and the hand crank rotated until the wheel carrier pan is in contact with the ground. At this point the lever is shifted to the "winch" detent and, with the winch bridle attached to the helicopter landing gear, the helicopter (nose or tail wheel) is winched on to the carrier pan. The control lever is then moved back to the "raise/lower" position, and the hand crank is rotated until the helicopter is raised to the "travel/lock" position.

The helicopter wheel carrier pan underside is designed with spades to minimize the problem of HGMS movement during the loading phase.

A single, swivel-type drive wheel, power pack (Military Standard A042 engine), and TORQMOTOR (T.R.W. Ross Gear) driving a sprocket/roller chain final drive, are arranged as an integral package. A simple, foldable hand control unit incorporating throttle, braking, and start/stop switch permits the crew member to "walk" the helicopter in either a forward or reverse direction.

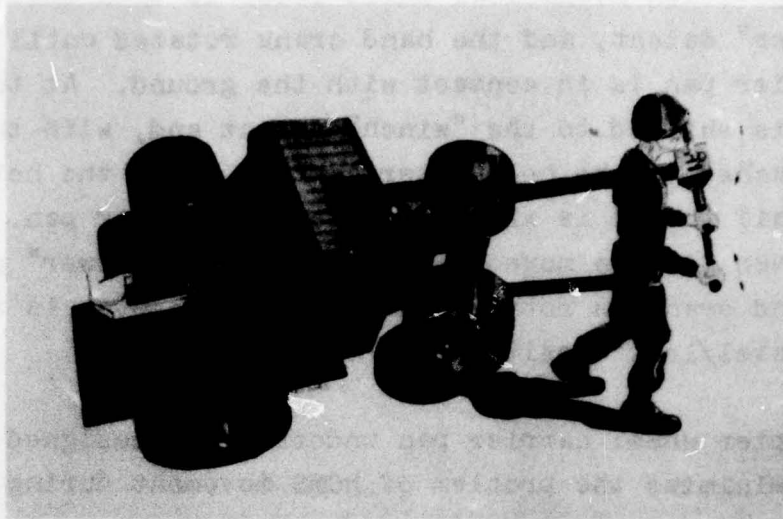

Figure 10. Concept 9B - Articulated Load-Transfer Mover

Similar in layout and function to Concept 9A, Concept 9B incorporates Military Standard 2A042, 18 hp engine, Sundstrand hydrostatic drive (pump and motor), Dana Spicer differential, and roller chain final drive which is contained in each of the rear element trailing arms.

Ausco disc brakes are fitted to the axle shafts and the two-position (load and transport) hydraulic rams raise and lower the helicopter wheel carrier by imposing a rotational force on the trailing arms. In contrast to Concept 9A, all functions, including winching, are accomplished hydraulically by means of a power takeoff from the propulsion drive system.

All control functions for the Concept 9B HGMS are contained in the foldable handlebar at the walking crew station. The HGMS can be operated in either direction (forward or reverse) with equal facility.

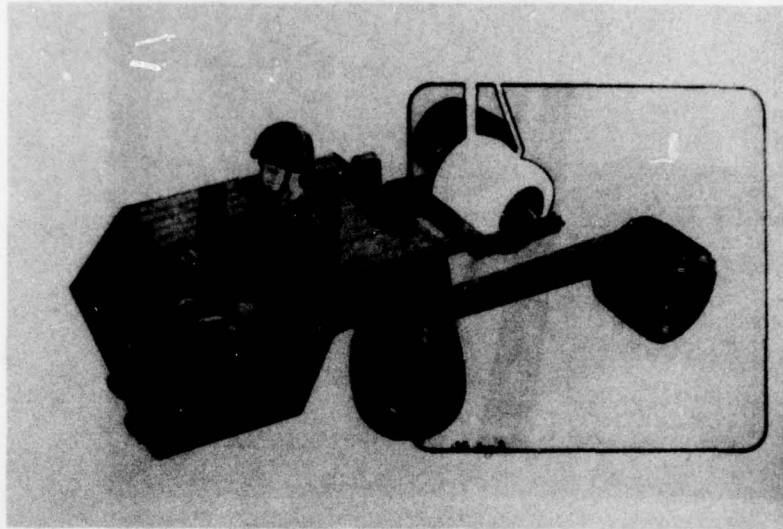

Figure 11. Concept 10 - Pivoting Frame Load-Transfer Mover

This pivoting frame HGMS design is configured to lift either the helicopter nose wheel or tail wheel to realize a weight transfer for the development of tractive effort.

The long trailing arms, which are pivoted at the vertical center-line of the leading axle, contain the hydraulic lines for the rearwheel Char-Lynn (Eaton) drive motors. Frame pivoting is accomplished with two vertical hydraulic jacks located 18 inches forward of the lead element (Ackermann-type steering) axle. Control of front axle steering is achieved by the lateral displacement of the control stick.

A fork-type, hydraulically activated and mechanically lockable, carrier engages the helicopter axle spindle (tow-bar) fitting to lift the helicopter clear of the surface. Lightweight flotation tracks are secured to the main gear wheels of the helicopter during movement. This HGMS concept employs an Onan CCKB engine to power the Char-Lynn hydrostatic drive system.

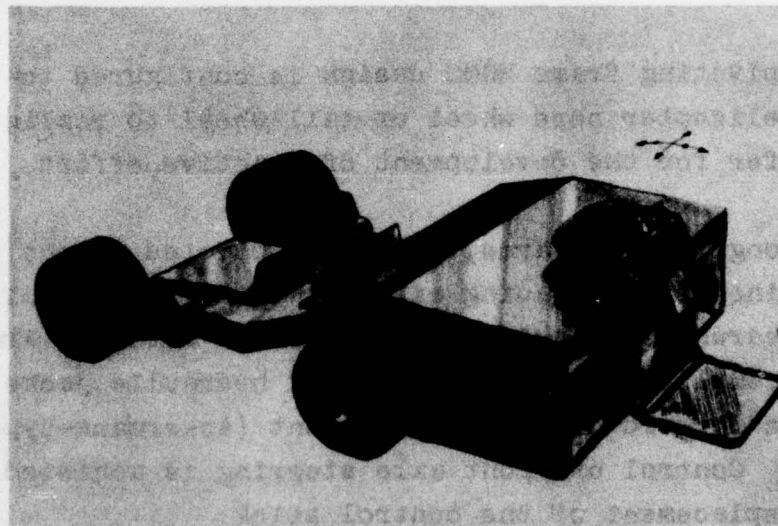
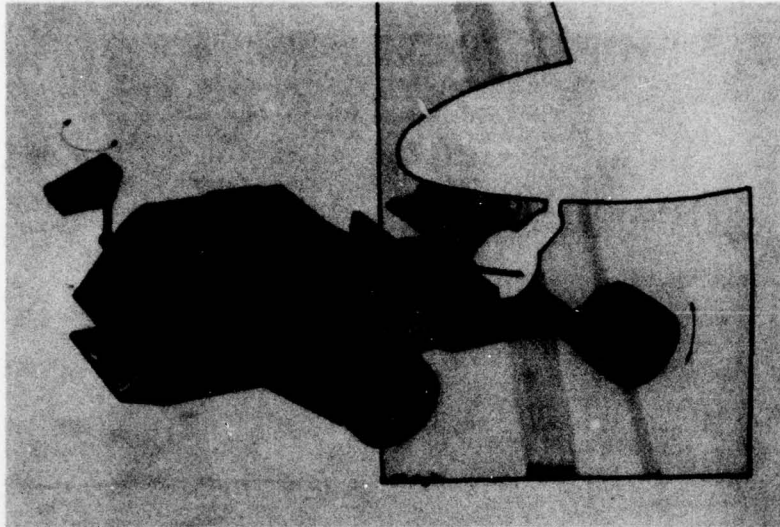

Figure 12. Concept 11 - Two-Element Load-Transfer Mover

This series of HGMS concepts is derived from the TEAMS aircraft mover design developed by Robert Forsyth in December 1962. The original TEAMS (two-element, articulated, aircraft mover system) was predicated on the transfer and use of a

portion of aircraft weight as ballast on the mover driving wheels.

While each of the mover concepts depicted is of the same general arrangement, they differ in terms of components, materials, and detail. Either differential (yaw) steering or articulated (yaw) power steering is employed. Either wide-base, low-profile conventional off-the-road tires or Goodyear Terra-Tires are employed. Each design employs an air-cooled gasoline engine in combination with a hydrostatic drive. Weights range from 1800 pounds to 2550 pounds and are dependent on the engine and drive train components, and the use of either steel or aluminum construction.

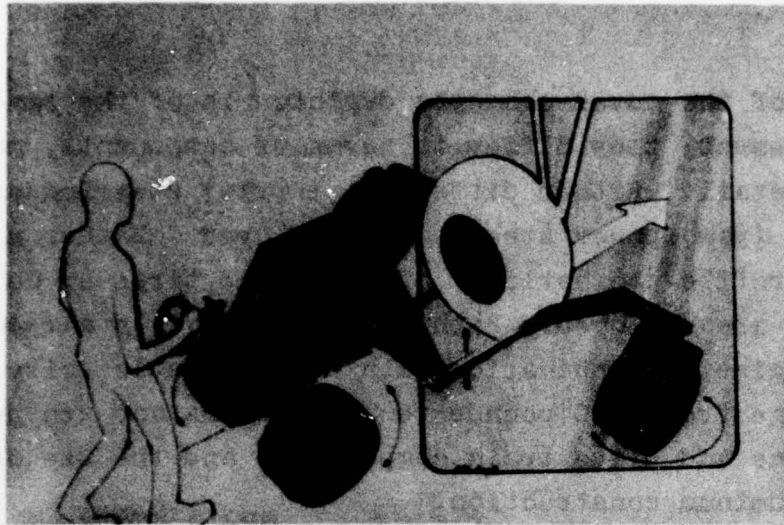

Figure 13. Concept 12 - Twin Auxiliary-Wheel Mover

This design is based on the idea of lifting only the main landing gear of the helicopter to offload the wheels and to spread the weight borne by each main landing gear assembly out over the larger footprint provided by the four flotation tires of an auxiliary propulsion device. This device incorporates a light, air-cooled engine of 20 hp producing input power for a hydrostatic drive that propels two driving wheels mounted on a steering post. The leading, castered wheels support two hydraulically actuated arms.

Two of the devices would be used to move a helicopter. The helicopter's main landing gear would be engaged from the side, and the landing gear wheels would be lifted for partial off-loading by the parallel arms acting like a forklift. The walking operator on each side of the helicopter would steer the driving wheels for forward or rearward movement and apply power. The castered wheels, supporting the major portion of the helicopter's weight, would orient themselves to the direction of travel as the devices started to move the helicopter.

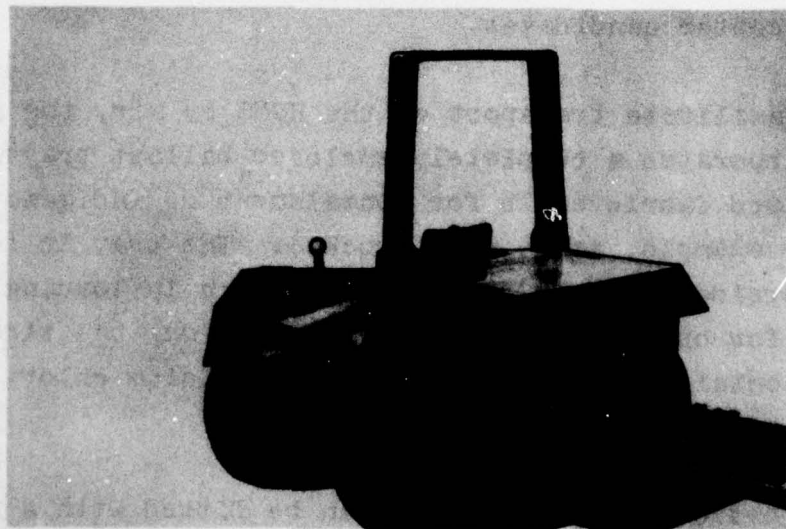
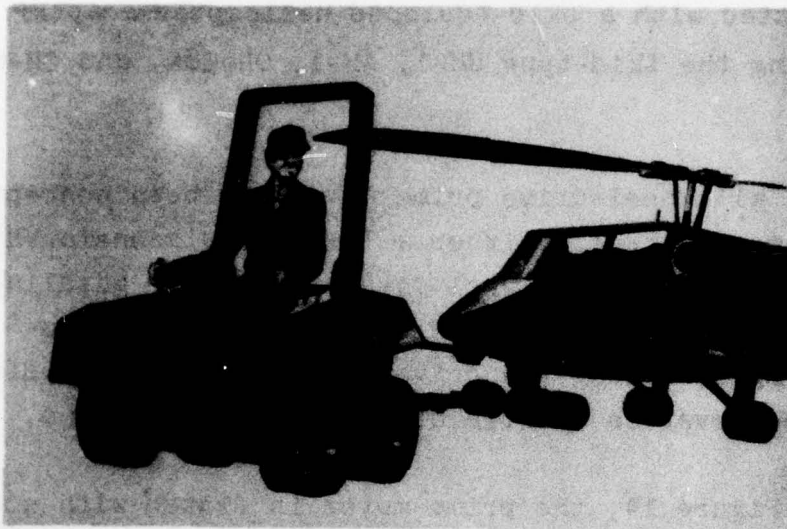

Figure 14. Concept 13 - All-Wheel-Drive Prime Mover

In combination with wraparound flotation tracks and a towbar with flotation wheels, this HGMS concept is capable of moving all of the UTTAS and AAH wheeled helicopter candidates. The towbar, when fitted with a skid-equipped helicopter adapter is capable of moving the skid-type UH-1, AH-1, OH-58A, and OH-6A helicopters.

The four-wheel, all-wheel-drive prime mover has been concepted in both aluminum and steel. Either a Teledyne Wisconsin VH4D or Military Standard 4A084 (diesel developmental or gasoline) engine is utilized in conjunction with a Sundstrand hydrostatic drive. By operating the drive motors in opposite directions, the prime mover is capable of pivot-in-place turns.

As depicted in Figure 14, the prime mover is fitted with stowage provisions for the towbar, and, with the two-position ROP bar folded, it can be transported internally in both UTTAS helicopter candidates.

To facilitate transport of the HGMS by air, the prime mover incorporates a completely enclosed ballast tray with five rubberized fabric cells for containment of indigenous ballast (for example, sand, dirt, rocks). The tray is located on the underside of the HGMS for convenience in loading and unloading and for optimum stability. In addition, the tires are capable of containing 90 to 120 pounds of calcium chloride if required for additional ballast.

The basic HGMS prime mover can be fitted with a dozer blade, forklift attachment, ordnance loader, or could be employed as a general-purpose towing tractor in Army aviation units.

The HGMS tire profile (section) is identical to the 8.5 x 10 helicopter main landing gear tire which permits the use of the flotation tracks on the prime mover. The additional track length required is obtained by adding links. The incorporation of an increased capacity alternator and air compressor permits the use of the HGMS prime mover as a power source for hand tools, lighting, tire inflation, and miscellaneous maintenance tasks.

Figure 10 - Wheel Flotation System

Typical of several self-powered RWD concepts, this design employs a pair of air-turbine motors, driving the drive shafts which are coupled to wheel-mounted, cast-iron traction gears. As with the previously mentioned RWD concept, helicopter flotation is achieved by water-saturated tracks.

Air for the air-turbine motor drive system is obtained from the helicopter APU. Directional control of the helicopter on the ground is accomplished with the autorotation (hand) pedals, and speed is regulated by a hand throttle in the cockpit.

Since a hydraulic drive or electric drive system would be substituted for the concept detailed.

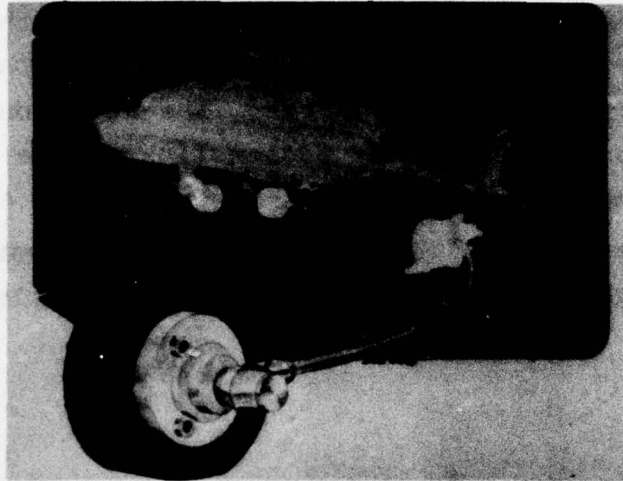

Figure 15. Concept 14 - Wheel Propulsion System

Typical of several self-powered HGMS concepts, this design employs a pair of air-turbine motors, driving flexible shafts, which are coupled to wheel-mounted, cuff-type reduction gears. As with the previously described HGMS concepts, helicopter flotation is achieved by wraparound tracks.

Air for the air-turbine motor drive system is obtained from the helicopter APU. Directional control of the helicopter on the ground is accomplished with the antitorque (rudder) pedals, and speed is regulated by a hand throttle in the cockpit.

Either a hydrostatic drive or electric drive system could be substituted for the concept depicted.

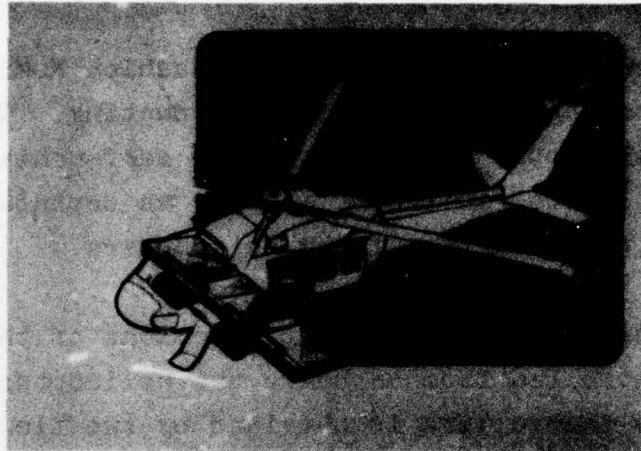

Figure 16. Concept 15 - Air-Cushion Mover System

Depicted in Figure 16 moving the Sikorsky UH-60A UTTAS helicopter, this air-cushion HGMS concept incorporates a number of novel features. The design has a modular layout, for example, with each air/lift cell configured dimensionally to permit transport as an internal UTTAS load. This HGMS concept could accommodate both AAH and UTTAS competitors.

To facilitate tracking and provide for positive directional control, the air-cushion HGMS employs a pair of differentially driven low-pressure rollers. The pneumatic rollers are bolted to a laterally disposed box-beam which is the basic structural member of the assembly. The helicopter main landing gear is accommodated in treadways, the sides of which are the principal lengthwise structural members.

For helicopter loading and unloading, the air cushion is evacuated and the treadways form inclined ramps. With the helicopter secured by means of the landing gear strut tiedown rings,

the air cells are inflated and the helicopter is ready to be moved.

The skirted plenum chambers of the air-cushion HGMS receive air from a centrifugal fan via flexible ducting. The fan, engine, and fuel supply are a completely self-contained package and can be located in the helicopter as depicted or mounted on a weapon pylon on the attack helicopters.

The power and differential steering functions of the pneumatic rollers are controlled from on board the helicopter. Power transmission to the rollers is obtained by two flexible-shaft reduction gear assemblies.

3. HGMS CONCEPT SCREENING AND EVALUATION

3.1 PRELIMINARY SCREENING

As noted previously, the screening of the HGMS candidate designs involved three steps, including: An initial elimination based on obvious technical, operational, or cost problems; a second, more detailed evaluation employing a matrix to assess parameters such as payload, weight, and ground pressure; and the final selection of a concept for further development based on a comparison of the physical, functional, and cost characteristics of the designs surviving the first and second evaluations.

The HGMS candidate designs eliminated in the first step of the screening process included the following:

Concept 3 - "Kneeling" Wheeled Carrier Frame

A towed HGMS, this concept has an estimated weight of 7,500 lb, which, with the eight high-flotation tires, and an assumed high weight for the typical helicopter of 16,000 lb, would result in ground pressure of approximately 24 psi, providing mobility adequate to meet the stated performance requirement. However, the physical size of the system would cause air transportability problems, acquisition and maintenance costs would be relatively high, its use in the field would result in relatively long turnaround times (for example, winching the helicopter onto and off of the frame), and its use would require the availability of a separate prime mover in the laager area.

Concept 4 - Track-Laying Platform-Type Carrier

Three of the individual HGMS designs fall generally into a type of track-laying carrier incorporating a wheeled forward portion with a T-shaped or triangular-shaped platform to provide a supporting base for carriage of the helicopter. The track assemblies are mounted to the rear of the platform, under

the area of major concentration of helicopter weight. The relatively large contact area of the tracks would give a ground pressure of approximately 16 psi which would result in excellent mobility in the specified soil conditions. The shortcomings of the concept, on the other hand, including high cost, a lack of air transportability, and excessive load/unload times, outweigh the mobility advantage.

Concept 5 - Straddle-Lift Carrier

This straddle-lift, track-laying, helicopter movement system, constructed of high-strength, lightweight materials would have an estimated weight of 10,500 lb which, when related to the typical helicopter gross weight and the contact area of the tracks, would provide a low ground pressure of 10 psi. However, the obvious complexity and cost of the system, combined with a need for a high level of operator skill and obvious deficiencies from the standpoint of air transportability, are not entirely compensated for by mobility advantages and the potential for relatively short turnaround times for helicopter ground movement.

Concept 7 - Telescoping Twin-Boom Carrier

A self-propelled system, this HGMS design has a calculated empty weight of 8,500 lb and an approximate ground pressure of 21 psi with a helicopter on the carrier. As with the other concepts that were eliminated from additional development, this twin-boom, telescoping, wheeled carrier would be difficult to transport by air, would require relatively long periods of time to load and unload helicopters, and would be complex to manufacture and maintain. It would also have a relatively high acquisition and life-cycle cost.

Concept 8 - Wheeled Sling-Type Carrier

This self-propelled, sling-type helicopter transporter, with a running gear carrying eight high-flotation tires on the cradle assembly, would have a ground pressure of approximately 26 psi based on an estimated gross weight of 25,500 lb for the transporter with a helicopter on board. The drawbacks of this design include a high potential for helicopter damage if the system is deployed in the field, and, while it would possess adequate mobility for the selected soil conditions, it would be costly to develop and produce and difficult to maintain in the field. Additionally, it could not be transported by any of the aircraft expected to be found with Army aviation units.

Concept 12 - Auxiliary Wheel System

This concept relies on the combined ground contact area of the HGMS high flotation tires and the helicopter main landing gear to provide a ground pressure of approximately 38 psi, assuming a system weight (two devices) of 2,000 lb and a gross weight of 16,000 lb for the typical helicopter. While it could obviously be adapted for quick engagement, this concept would be difficult to employ because of the coordination problems between operators on each side of the helicopter, and it would provide only a moderate increase in helicopter mobility. Consequently, despite weight and size advantages, the concept was not subjected to further development.

The foregoing elimination of concepts in the initial screening process was accomplished by VSDC, and reported to and concurred with, by USAAMRDL and the representatives of other Army agencies in the concept review and selection meeting held at the contractor's facility midway through the program.

3.2 MATRIX ANALYSIS

The second step of the screening process involved the development of additional data on the concepts surviving the first-cut elimination so that they could be evaluated by a simple matrix analysis. The parameters examined, as shown in Figure 17, included mobility, speed, maneuverability, gradeability, payload, stability, and transportability as related to Concepts 1, 2, 6, 9 through 11, and 13 through 15.

The prediction of mobility was based on the application of equations developed by the U.S. Army Engineer Waterways Experiment Station (USAEWES). These equations, covering wheeled and tracked, self-propelled and towed vehicles, by weighting of certain vehicle characteristics, provide a Mobility Index (MI) figure which can be converted to a Vehicle Cone Index (VCI) so that comparisons can be made with soil conditions defined by a Cone Index (CI) or Rating Cone Index (RCI) to determine the expected trafficability. The VCI values calculated for the surviving HCMS concepts are presented in Table 1 and discussed in detail in Appendix A.

HCMS CONCEPTS

	1	2	6	9	10	11	13	14	15
Mobility	(N)	(N)	(N)	Y	Y	Y	Y	Y	Y
Speed	Y	Y	Y	Y	Y	Y	Y	Y	Y
Maneuverability	Y	(N)	(N)	Y	Y	Y	Y	Y	(N)
Gradeability	(N)	(N)	(N)	Y	Y	Y	Y	Y	(N)
Payload	Y	Y	Y	Y	Y	Y	Y	Y	Y
Stability	Y	(N)	(N)	Y	Y	Y	Y	Y	Y
Transportability	Y	(N)	Y	Y	Y	Y	Y	Y	Y

(N) = Not Acceptable Y = Acceptable

Figure 17. Matrix Analysis

TABLE 1. HGMS CONCEPT VEHICLE CONE INDEX (VCI_1)

HGMS Concept	Calculated VCI_1^a
1	51
2	45
6	43
9A	23
9B	24
10	24
11	25
13	21
14	35
15	25

^a VCI_1 relates to soil strength required for a single passage of vehicle over terrain as opposed to the (usually higher) requirement for repeated passages (designated VCI_{50}).

The relatively poor mobility of Concept 1 results from the fact that even though they are driven, there are only two wheels carrying flotation tires on the frame and, in effect, only one axle. Consequently, with the gross weight of the combination of the helicopter, the frame and the leading element of the M561 truck, there is substantial reason to expect extensive sinkage and high motion resistance in the specified soil with a CI of 50, and the formula analysis to determine a mobility index and VCI_1 confirms this expectation.

Much the same situation applies to Concepts 2 and 6 where the flotation provided is not sufficient to avoid extensive sinkage and motion resistance. With regard to the VCI_1 of each of these concepts, 45 and 43 respectively, it should be noted that, while the ratings are below a CI of 50, the spread is inadequate to provide sufficient reserve mobility to assure

successful negotiation of the specified grades. As a result, the accompanying matrix reflects failures of the concepts on both mobility and gradeability just as it does for Concept 1. Concepts 9 (9A and 9B for slightly different configurations of the same basic design) and 10 were rated as inadequate on mobility and gradeability originally in the matrix analysis because they were not considered in combination with the use of high-flotation tracks on the main landing gear of the UTTAS and AAH helicopters. The inclusion of this factor in the recalculation of the VCI_1 figures for these concepts resulted in a VCI_1 of 23 and a VCI_1 of 24, respectively, which are indicative of satisfactory mobility and adequate reserves to meet the required gradeability in the expected operating environment.

Concepts 11 and 13, with a VCI_1 of 25 and a VCI_1 of 21 respectively, require no discussion, as they fully meet mobility and gradeability criteria. Concept 14, the concept in which the main landing gear of the helicopter is driven by a power means integral to the helicopter, on the other hand, is marginal. The relatively poor VCI_1 of 35 reflects the fact that, even though high-flotation track assemblies are attached to the driven wheels of the main landing gear, the unit loading of the tracks is high and therefore sinkage and motion resistance can be expected to be extensive, and this situation is made worse by the use of differential track speeds for steering. Nevertheless, the concept offers other advantages such as transportability and ease of control which justify satisfactory ratings in the matrix on the assumption that further development could produce some improvement in mobility and gradeability.

Concept 15, where use is made of an air-cushion device to partially offload helicopter weight from the device's running gear, quite naturally has a good mobility rating on level

ground because of the low unit loading that can be achieved. However, the resulting loss in frictional contact with the terrain being negotiated would cause grade performance to be relatively poor and would create problems in maneuverability. Consequently, the matrix shows unsatisfactory ratings for both these parameters.

Returning to Concepts 2 and 6 and their capabilities to meet matrix parameters or criteria, it will be noted that both have been rated unsatisfactory on stability. This is a consequence of the height from the ground of the center of gravity of the combination of the helicopter and transporter, which is caused by the helicopter being taken completely out of ground contact by the twin-boom carrier frame and the cradle-lift device and raised substantially above ground level to assure good clearance. The resultant instability would, of course, be most apparent and troublesome on side slopes.

Both Concepts 2 and 6, additionally, received unsatisfactory ratings on maneuverability, primarily because the long wheel-base of each would prevent a small turning radius and would also present difficulties in reverse movements. Concept 2 also received an unsatisfactory rating on transportability because, despite the ability to extend and retract the boom assemblies and to draw them together and extend them directly behind the prime mover, it would not be practical to move this HGMS by air with any of the aircraft to be found within Army aviation units.

Summarizing the results of the matrix analysis, Concepts 1, 2, 6, and 15 were eliminated from further consideration for development as viable HGMS candidates.

3.3 COMPARISON PROFILE EVALUATION

The third and final step in the HGMS candidate screening process involved the preparation of comparison profile charts on Concepts 9 (9A and 9B are considered as one basic design), 10, 11, 13, and 14. This included examination of an expanded list of parameters or criteria and the introduction of system cost as a basic factor in decision making.

The charts are based on an averaging of ratings for various concept characteristics to establish a baseline, or what may be termed an "average" HGMS that all the concepts may be evaluated against to determine how much the capabilities of each fall above or below average. The cost line included in each comparison profile chart reflects the estimated life-cycle cost of the HGMS concept, based on an initial production run of 500 units and an expected unit life of 8 years in normal service. Examination of the charts, shown in Figures 18 - 22, in addition to showing the percentage by which the rated HGMS concept exceeds or falls below average in capabilities and features also indicates how much capability can be obtained for each dollar of cost or investment.

As may be seen from the charts, all the concepts are rated equal or average for three characteristics: speed, stability, and endurance/range. The maximum speeds required on level ground, 1 mph in soils with a CI of 50 and 3 mph in soils with a CI of 125, assuming, as is the case, mobility in these conditions, are achievable by all five concepts. Likewise, since none of the concepts, when in use with the helicopters, involve any substantial upward displacement of the integrated CG (helicopter and HGMS combined) there is no significant change from the longitudinal and lateral stability exhibited by the helicopters alone. Because endurance/range is a simple function of HGMS fuel capacity and consumption, and similar

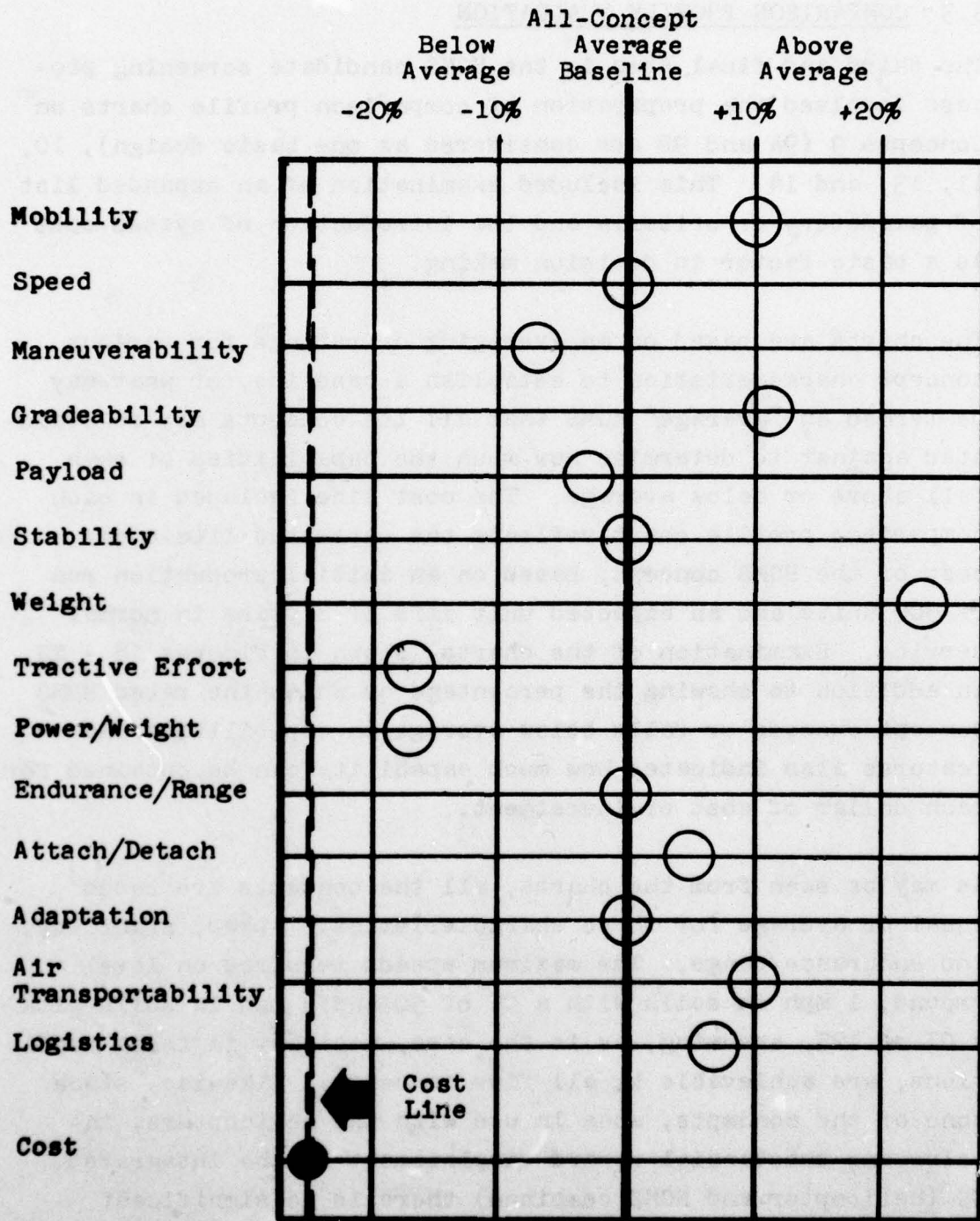

Figure 18. Concept 9 - Comparison Profile Chart

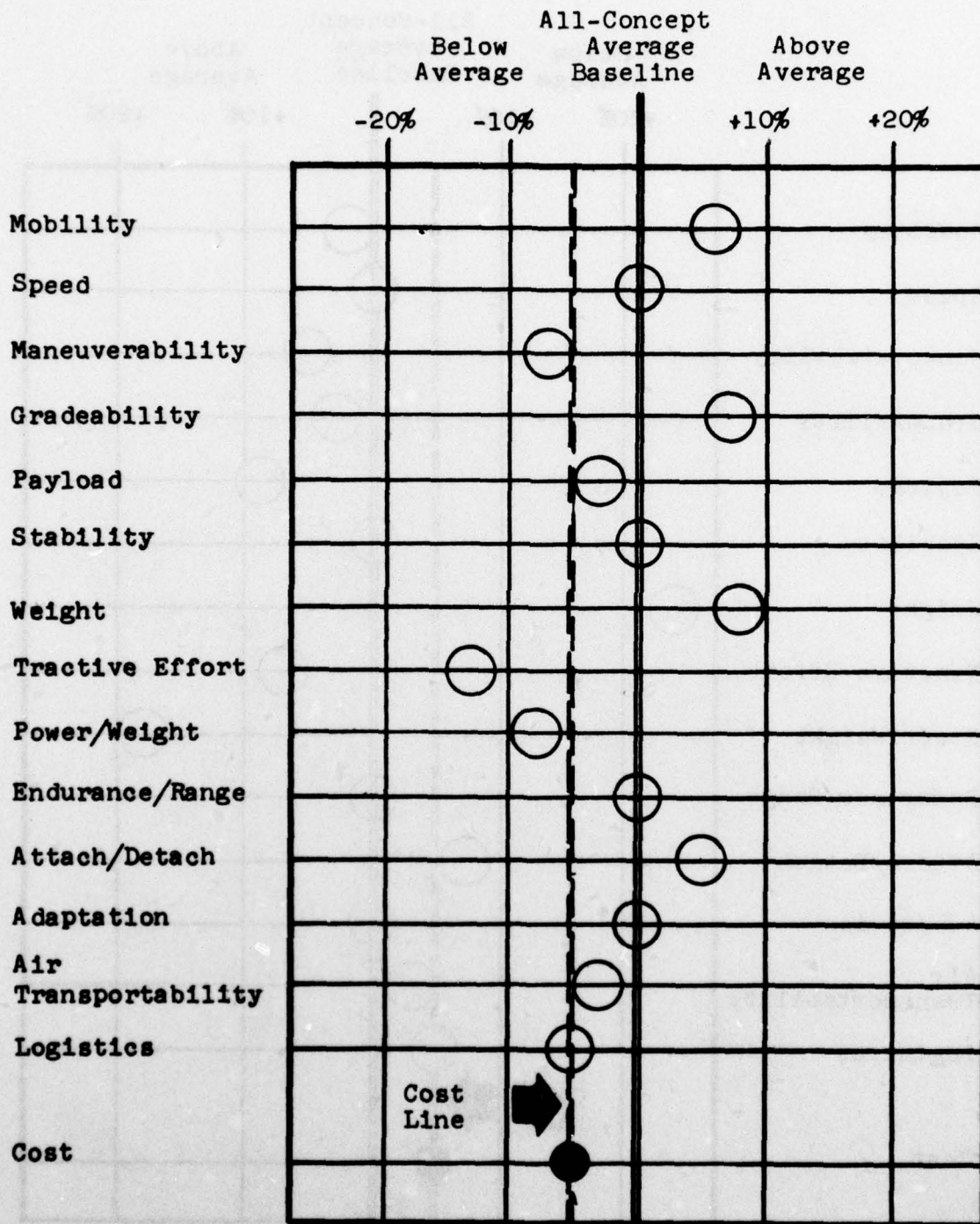

Figure 19. Concept 10 - Comparison Profile Chart

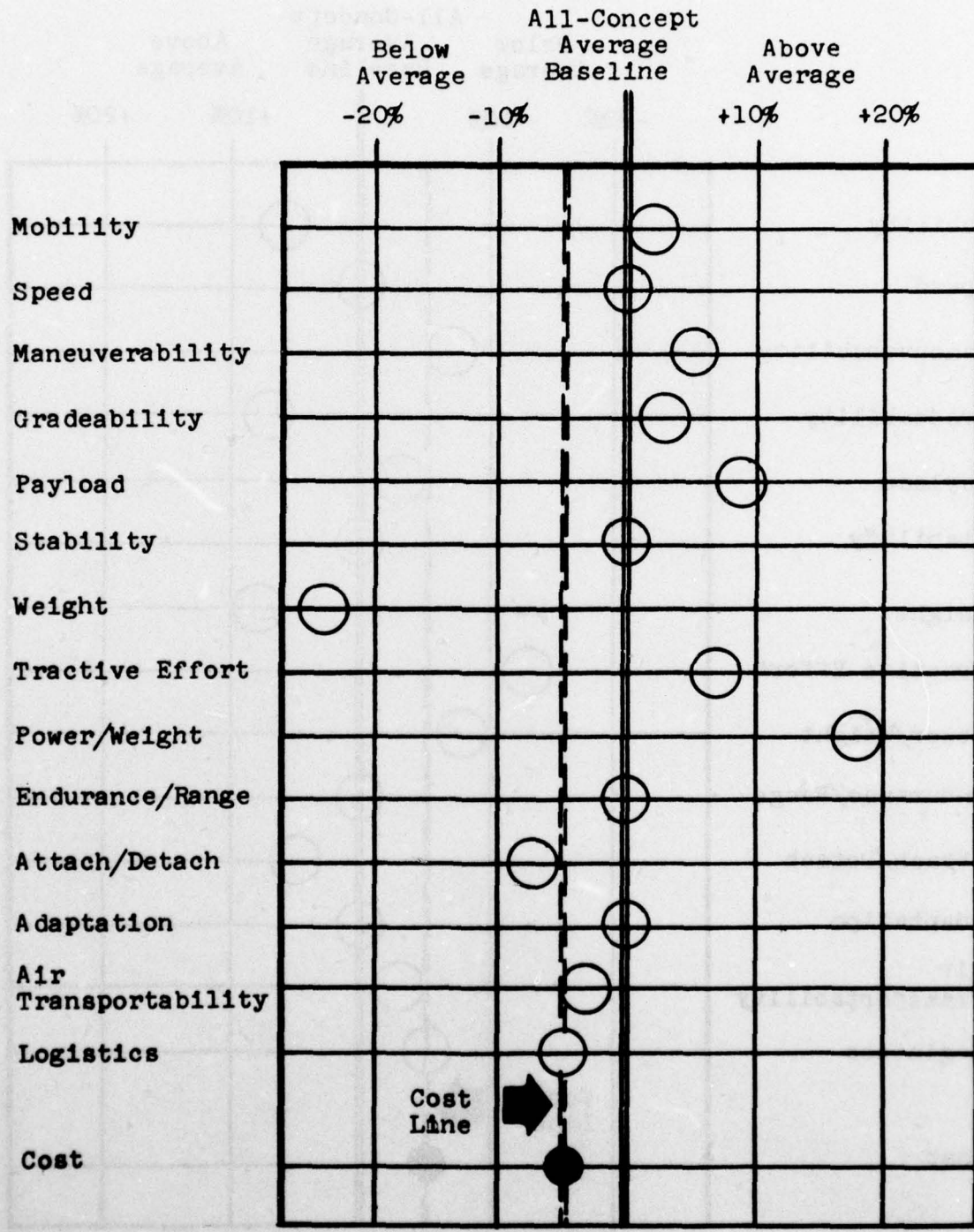

Figure 20. Concept 11 - Comparison Profile Chart

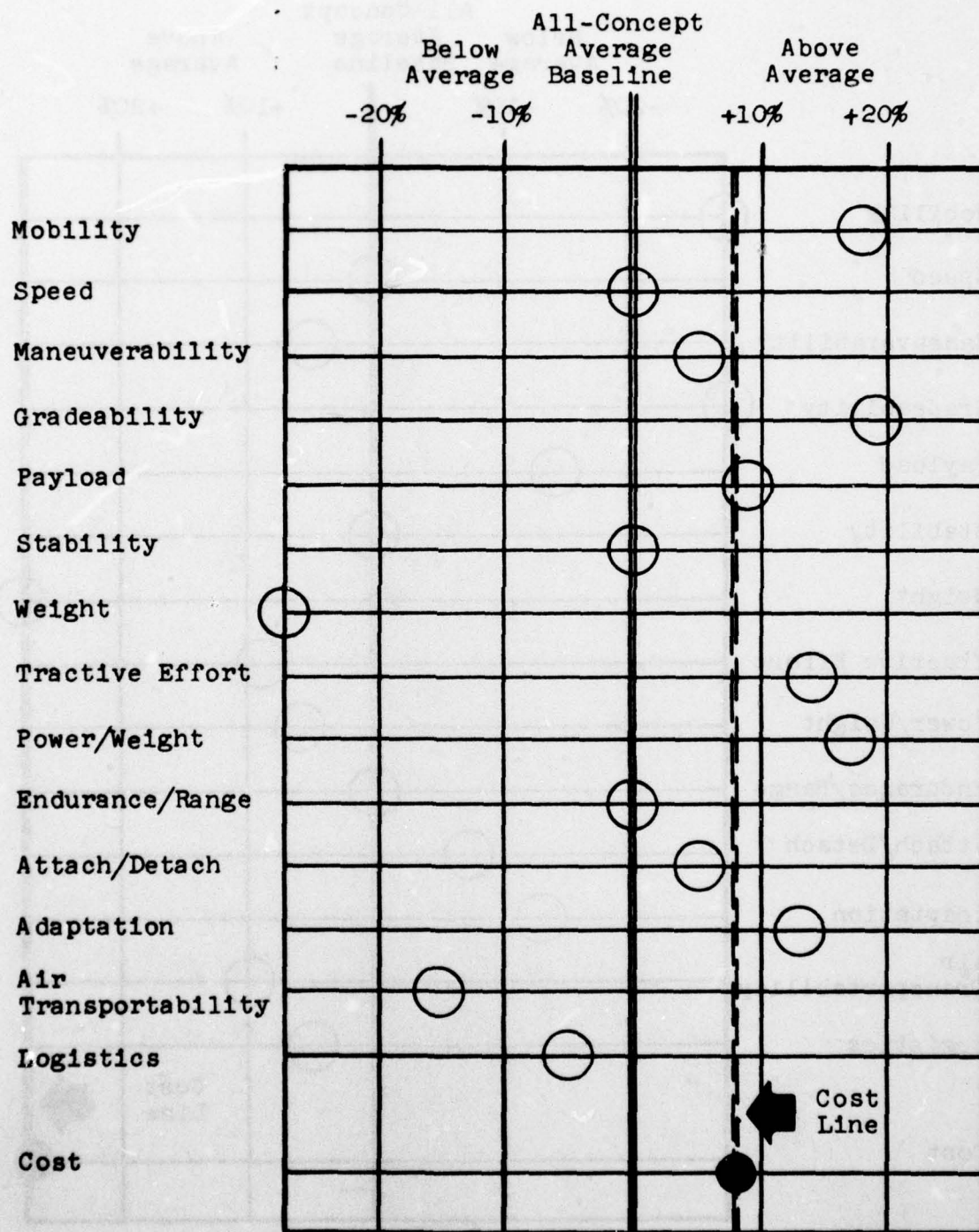

Figure 21. Concept 13 - Comparison Profile Chart

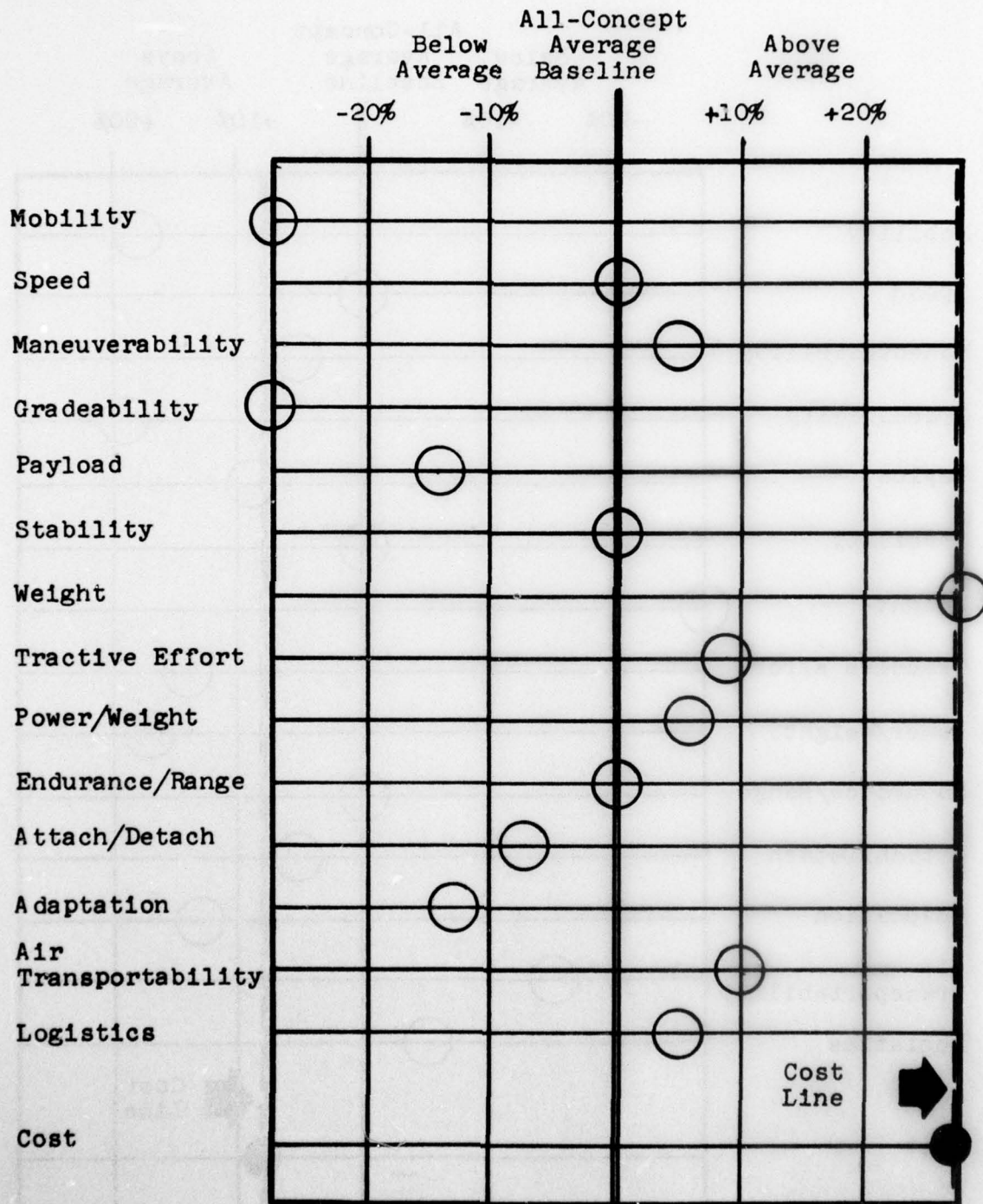

Figure 22. Concept 14 - Comparison Profile Chart

ratios for each concept may be readily obtained as a function of the design process, they can be made equal in this respect.

As has been discussed before in connection with the matrix analysis, the characteristics of mobility and gradeability in the specified soil conditions are directly related. First, the ability to move across level ground must be satisfied, as indicated by a VCI_1 for the HGMS which is lower than the soil's CI and, second, the spread between the HGMS VCI_1 and the soil's CI must be sufficient to assure the required gradeability.

Concepts 9 (representative of Concepts 9A and 9B), 10, 11 and 13 offer above average capability on both counts, with Concept 13 exceeding the average by nearly 20 percent. Because of the high unit loading of the auxiliary tracks on Concept 14, flotation is marginal and sinkage and motion resistance would be high, resulting in substantially below average mobility and gradeability. The maneuverability exhibited by Concepts 11, 13, and 14, primarily turning and reverse operations, is above average and approximately equal. However, Concepts 9 and 10 would be somewhat limited in this regard because of the type of steering employed and the loading on the steered wheels. Consequently, they fall below average on this characteristic.

In examining payload capability, it is obvious that a basic design consideration for all five HGMS concepts was the provision of enough power and physical capacity to accommodate a helicopter with a 16,000-lb gross weight. Thus all the surviving HGMS concepts (9, 10, 11, 13, and 14) covered in the comparison profile charts are equivalent in that regard. However, payload capability as compared in the charts also includes adaptability to other functions in addition to moving the AAH and UTTAS helicopters. This adaptability could include, for example, employing the HGMS with additional accessory equipment,

move skid-equipped helicopters, or tow other items of support equipment. Concepts 9 and 10 are limited in this respect and fall below average in this characteristic. Concepts 11 and 13, on the other hand, may be employed to move skid-equipped helicopters as well as move other types of ground support equipment. Therefore, they are both rated average on this count.

The weight of the HGMS is an important consideration in evaluating the candidate systems, primarily because it bears directly on air transportability. As with such parameters as mobility, speed, and gradeability, the ratings on the comparison profile charts were arrived at on a quantitative basis. The average weight for the five concepts in final consideration is 2100 lb. Ratioing the transport weight of each candidate against this figure results in the percentage ratings above and below the optimum weight reflected by the average baseline on the charts. As may be expected, Concepts 11 and 13, with the highest weights, are less than optimum concerning this characteristic.

Tractive effort, as a candidate system rating characteristic, is related to the weight of the system, the power-to-weight ratio, and the mobility rating of the HGMS concept. Adequate power without sufficient weight on the driven wheels to convert the power to tractive effort, or insufficient mobility to avoid soil failure before full tractive effort is developed made it necessary to evaluate this parameter on a figure-of-merit basis to make it meaningful. As would be expected, the heavier systems with greater power and above-average mobility (Concepts 11 and 13) provide the most capability. Concept 14, while it possesses adequate power and weight on the driven wheels (the helicopter's main landing gear with auxiliary tracks), has a lower rating because of relatively poor mobility. Concepts 9, 10, and 14, with relatively low weights, are also

power-limited by virtue of size and space available for the power plant. Consequently, when the gross weight of the combination of the HGMS and a 16,000-lb helicopter is ratioed against available horsepower, the highest ratings are again associated with the heavier systems with higher output power plants.

While the attach/detach time for all five candidate systems is relatively similar, and Concepts 9, 10, and 13 are above average on this characteristic, Concepts 11 and 14 fall short of the average. In this judgemental process used to derive figures of merit for this characteristic, on Concept 11 consideration was given to the problem of using the system with the Bell AAH helicopter, and to Concept 14 which requires a precise fitup of close-tolerance drive components for attachment to the helicopter main landing-gear wheels. Similar considerations affected the equivalent ratings for Concepts 9, 10, and 11 on the average baseline for adaptation to the two AAH and UTTAS helicopters, and the above-average rating for Concept 13 where a standard towbar accommodates all four helicopters. The below-average rating for Concept 14 results from the fact that the dissimilar main landing gear of each of the four helicopters would require "customized" adaptation hardware to enable installation of the basic drive system. This would mean that each HGMS would be comprised of a number of functionally duplicated parts.

Air transportability is, of course, a function of physical size and weight. Consequently, the smallest and lightest concepts, 9 and 14, achieved above-average ratings on this parameter and Concepts 10, 11, and 13, progressively heavier and larger systems, received below-average ratings. Considering the logistic implications of each of the five candidate systems involved a judgemental process to derive figures of merit,

with judgements being influenced by such factors as the approximate numbers of parts and major components used in each system, the compatibility of the systems with existing parts stockage and logistics support, and an evaluation of the potential for system failures and the need for repairs. Concepts 9 and 14 were rated above-average for logistics because of the mechanical simplicity of the former and the compatibility of the latter with existing logistics support systems for aircraft.

The discussion of the comparison of the five candidate systems thus far has been limited to a review of the relative capabilities of the systems and their physical characteristics. On this basis Concept 13 appeared to offer the greatest overall advantage in capabilities and features, and Concept 14 represented a marginal approach to satisfaction of the HGMS mission requirement. However, decision-making on which concept, or concepts, are, in fact, the most promising and therefore deserving of additional development must also include a consideration of cost. Obviously, if system acquisition cost is so high that it would be infeasible for the Army to procure the number of systems required to fully support its active aviation units, then, regardless of how superior the system's capabilities and features may be, it will represent an unsatisfactory approach to the requirement.

To include cost in the subject analysis in a meaningful way, it was first necessary to develop estimates of the total or life-cycle cost of each different candidate system, and then provide a means to evaluate this cost in terms of the performance and features it would buy. Life-cycle cost per unit has been first estimated by determining the expected development costs, calculating the expected production costs on the basis of a serial production run of 500 units, and determining maintenance and repair costs per unit over an 8-year service life.

No provision has been included for personnel costs because special training requirements for any of the candidate systems would be minimal, and employment of the systems would not require exclusive dedication of personnel to their operation. The estimated life-cycle unit costs are presented in Table 2.

TABLE 2. ESTIMATED LIFE-CYCLE UNIT COSTS

Concept	Development Costs ^a	Production Cost	Maintenance Cost	Life-Cycle Unit Cost
9	\$216,820	\$13,136	\$394/yr - 8 yrs	\$16,700
10	233,320	16,480	494/yr - 8 yrs	20,900
11	233,320	16,480	494/yr - 8 yrs	20,900
13	241,320	18,912	567/yr - 8 yrs	23,900
14	244,820	22,780	683/yr - 8 yrs	28,700

^aDevelopment costs are amortized over an initial production quantity of 500 units.

These figures include prorated development costs ranging from \$216,820 to \$244,820, including \$94,000 of HGMS and skid-equipped helicopter adapter concept development work.

Concept 14 has a high cost because the air motor or turbine drive system involves the use of high-value components (quotations have been received with prototype unit costs ranging from \$5,800 to \$10,000 and production unit costs ranging from \$3,000 to \$5,000 in quantities of 600 to 1,000 units) designed and manufactured to aircraft rather than automotive standards as are the components for the other candidate systems. The necessity for the use of such components arises from the fact that certain of the components of the integral drive system become part of the helicopter system. It should also be noted that the estimated costs for the integral drive system package

of Concept 14 do not include any costs that would be associated with the modification of the helicopters necessary to adapt them to use of the system. For example, for any of the four helicopter models it would be necessary to install additional bleed-air line plumbing from the APU to provide a quick-attach/detach coupling for air supply to each of the motors. Obviously these costs will be significant and should logically be applied as part of the total system cost. However, there is no reasonably accurate way to estimate such costs at this point so there is no reliable means by which they can be taken into account.

The estimated candidate system life-cycle costs were averaged to arrive at a baseline system cost. This is represented on the comparison profile charts by the average baseline. The percentage by which the estimated cost of each system is above or below the average cost was then calculated and included in the charts as the "cost line". This line may be used in conjunction with the percentage ratings of system capabilities and features to evaluate the cost-benefit aspects of the concepts. For example, in the Concept 9 chart (Figure 18), the cost line is approximately 24 percent below the average baseline, which means this HGMS candidate has an expected life-cycle cost 24 percent below the cost of the average HGMS system. The cost line is also approximately 7 percent below the rating for tractive effort and the power-to-weight ratio, meaning that, per dollar of cost, Concept 9 offers 7 percent more capability relative to these two parameters than the average HGMS system does. This is true despite the fact that on a strict comparison basis (concept versus concept), Concepts 11, 13, and 14 possess above-average capabilities on these parameters. It should also be noted that the other concepts, for example, Concept 11, with a cost approximately 5 percent below average, offers roughly 12 percent greater tractive effort and

possesses a 23 percent better power-to-weight ratio than the average system for each dollar of cost. Consequently, if a choice were to be made between Concepts 9 and 11, based on these two parameters alone, the selection would be Concept 11 because it not only offers greater performance but also, despite a higher life-cycle cost, it provides a significant cost benefit advantage.

Analyzing the comparison profile charts in this manner, it becomes apparent that Concept 14, with a life-cycle cost roughly 30 percent above average (not including required helicopter modifications) and mobility and gradeability well below average, does not represent a promising approach for further development. Likewise Concepts 10 and 11, while offering certain cost benefit advantages, possess only average capabilities and features and therefore represent only marginal opportunities for additional development efforts. Concept 9, on the other hand, with an estimated life-cycle cost approximately 24 percent below average, has significant cost benefit advantages and offers somewhat better than average capabilities and features. Consequently, Concept 9 possesses the attributes which justify further development work. While Concept 13 does not, with an estimated life-cycle cost approximately 8 percent higher than average, offer cost benefit advantages like those of Concept 9, it is clearly superior to the other four concepts in capabilities and features.

3.4 CONCEPT SELECTION

Based on the findings of the three-step screening process used to select the most promising HGMS concept, and the extensive examination of these findings in the concept review and selection meeting held between the contractor, USAAMRDL, and representatives of USAAVSCOM and the U. S. Army Transportation School, midway through the program, it was determined that Concept 9 (a combination of the best features of Concepts 9A and 9B) offered

the greatest operational potential and the most advantageous cost benefit relationship. Consequently, USAAMRDL directed the contractor to concentrate all final design activity on translating this concept into a configuration suitable for prototyping.

Additionally, and subsequent to this decision by USAAMRDL, the contractor and USAAMRDL made a mutual determination that the selected HGMS concept could be effectively employed to mobilize skid-equipped helicopters on the ground through the use of an adapter device providing auxiliary flotation for such helicopters. To implement this determination, the subject contract was modified to include the task of preparing a preliminary design for the skid-equipped helicopter adapter.

An interesting aspect of the selected HGMS concept is its generic relationship to a design for a civil transport aircraft ground movement system developed in 1962. As can be seen from Figure 23, the TEAMS concept was a two-element articulated tractor with the rear element functioning as a load platform. The design was based on the idea of transferring aircraft weight borne by the nose landing gear to the tractor to increase its capability to develop tractive effort. A tractor incorporating this feature could thus be made much lighter and would require less ballasting than a conventional towing tractor for a given tractive effort requirement. Consequently, it would be more fuel efficient and reduce the damage to airport service roads attributable to the traffic of heavy, poorly suspended tractors.

4.

PROTOTYPE DESIGN

4.1 PHYSICAL AND PERFORMANCE CHARACTERISTICS

The Helicopter Ground Mobility System (HGMS) consists of a power module, developing motive power and tractive effort, and auxiliary devices to increase flotation and to reduce helicopter towing resistance. The basic system shown in Figure 24 incorporates a power module and a pair of flotation tracks which are capable of mobilizing, interchangeably, either of the advanced wheeled helicopters. An adapter, described in Section 4.2, extends that capability to include current generation, skid-equipped helicopters. The tractive effort and power requirements are discussed in detail in Appendix A.

The power module, common to all configurations, is essentially a small, four-wheel, walking tractor with a variable-height load platform at the aft end and the operators controls at the forward end. The two elements of the power module, the leading (power) unit and the trailing (load platform) unit are connected by a kingpin to permit yaw steering and a limited roll motion between units. The drive system provides selective two-wheel (rear axle) drive or full performance four-wheel drive.

The power unit consists of a light structure on which the engine, transmission, and forward drive train are mounted. The required power, as determined in Appendix A, is provided by a 16 hp Briggs and Stratton engine coupled to dual hydrostatic transmissions and Dana Spicer axles. This engine was selected after a review of available units producing the necessary power. Candidate engines, as shown in Table 3, included both gasoline and diesel fueled units in a power range from 13 to 40 hp. Selection criteria reflected considerations as to physical size and weight; the availability of options such as electric starter and generator or alternator, fuel pump, fuel tank, and spark

LOADING SEQUENCE

1. USING TWIST GRIP CONTROL, BACK HGMS UNTIL WHEEL PLATFORM IS APPROXIMATELY 4 FEET BEHIND AND IN LINE WITH HELICOPTER TAIL WHEEL.
2. USING JACK CONTROL VALVE, EXTEND JACKS AND RAISE HGMS REAR WHEELS SUFFICIENTLY TO RELEASE PIN-LOCKS. RETRACT JACKS, LOWERING WHEEL PLATFORM TO RAMP POSITION.
3. REMOVE FLOTATION TRACKS FROM WHEEL PLATFORM AND POSITION TRACKS IMMEDIATELY BEHIND AND IN LINE WITH MAIN LANDING GEAR WHEELS.
4. PLACE HYDRAULIC SELECTOR VALVE IN "PARK" POSITION, PAY OUT WINCH CABLE, USING WINCH CONTROLLER, AND CONNECT CABLE TO TAILWHEEL TOWING FITTING.
5. USING CONTROLLER, REEL IN WINCH CABLE UNTIL HELICOPTER TAIL WHEEL IS PROPERLY POSITIONED ON THE WHEEL PLATFORM RAMP. IN THIS POSITION BOTH MAIN GEAR WHEELS WILL BE RESTING ON THE FLOTATION TRACKS WITH BOTH ENDS OF EACH TRACK EXTENDED.
6. SECURE TAILWHEEL WITH WHEEL CHOCK AND CLOSE TRACKS AROUND MAIN GEAR WHEELS (SEE DRAWING HGMS-900-3).
7. EXTEND JACKS TO RAISE WHEEL PLATFORM UNTIL PIN-LOCKS ENGAGE. REVERSE JACK CONTROL TO TRANSFER LOAD TO HGMS WHEELS AND RETRACT JACKS TO STORAGE POSITION.
8. RETURN HYDRAULIC SELECTOR VALVE TO "DRIVE" POSITION, ENGAGING THE REAR WHEEL DRIVE SYSTEM OR, IF REQUIRED, SELECT "A-WHEEL DRIVE." THE HELICOPTER IS NOW SECURED AND READY FOR GROUND MOVEMENT.

BEST AVAILABLE COPY

BEST AVAILABLE

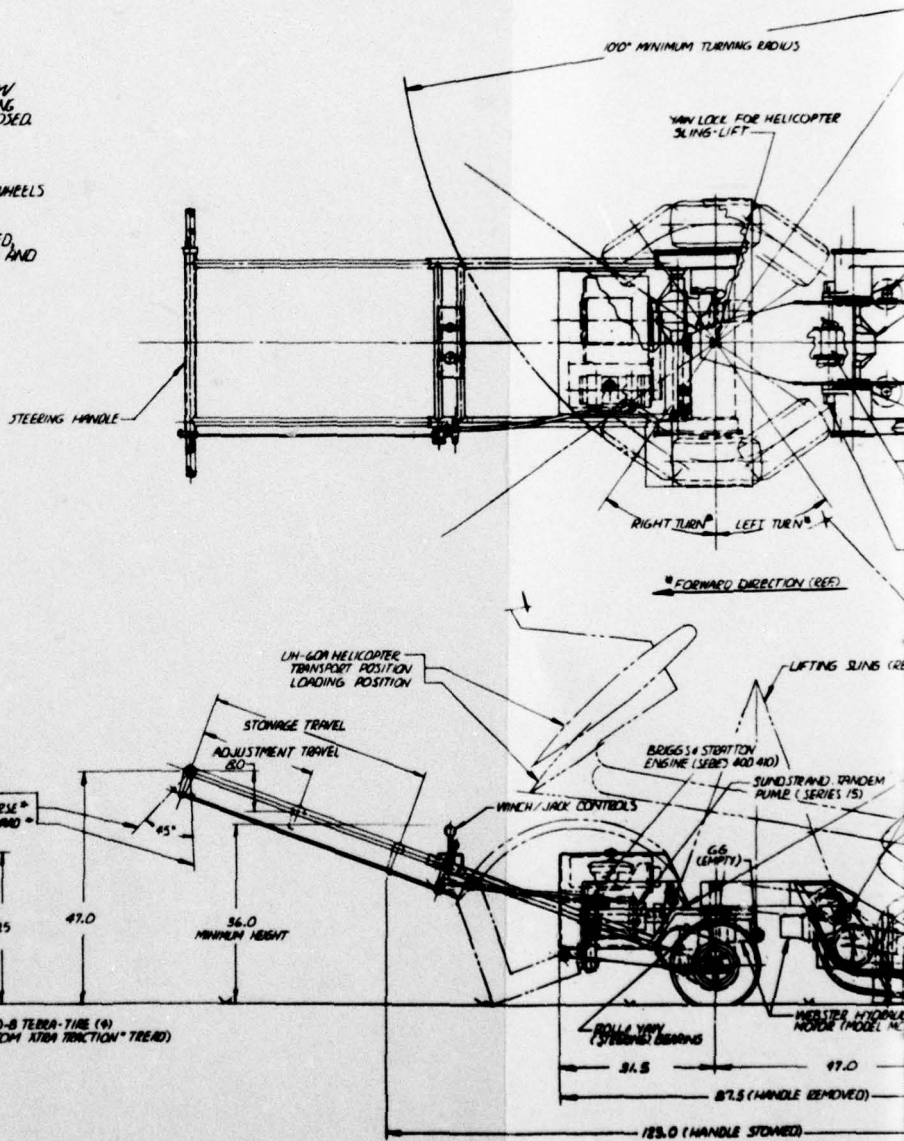
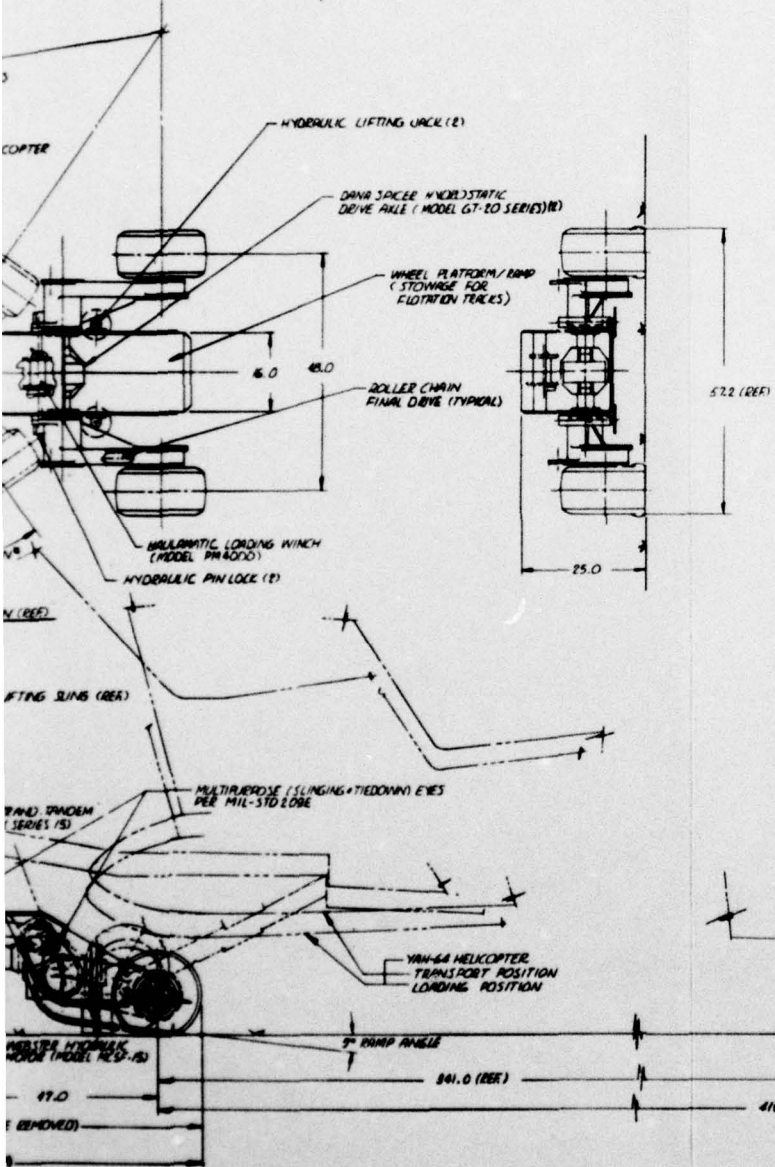

Figure 24. General Arrangement - Helicopter Ground Mobility System (HGMS)

AVAILABLE COPY



HGMS CONCEPT CHARACTERISTIC DATA

1. PERFORMANCE (WITH 1600 LB. HELICOPTER)

MAXIMUM SPEED	3.0 MPH
MAXIMUM GRADE	
SOIL BATING CONE INDEX-115	15 %
SOIL BATING CONE INDEX-50	9 %

2. CHARACTERISTICS

DRIVING WHEELS	417 OR 418 SELECTIVELY
WEIGHT (EMPTY)	800 LB.
FRONT UNIT	800 LB.
REAR UNIT	800 LB.
WHEEL PLATFORM CAPACITY	3000 LB.
ENGINE (BUGGSI STRATTON)	SERIES 4000-10
MAXIMUM OUTPUT	16 HP @ 3600 RPM
CONTINUOUS OUTPUT	12.6 HP @ 3600 RPM
MAXIMUM TORQUE	75.8 FT. LB.
TRANSMISSION (GEAR RATIO INDEPENDENT)	HYDROSTATIC
PUMP (SUNSTRAND)	SERIES 15 (TANDEM)
AXLE DRIVE MOTOR (WEBSTER)	MODEL MCF-15
MAXIMUM SYSTEM PRESSURE	3000 PSI.
AXLE (DANA-SPICER)	MODEL GT-20 SERIES
RATIO	20.9:1
FINAL DRIVE RATIO (ROLLER CHAIN)	1.57:1
TIRE SIZE (GOOD YEAR TERRA TIRE)	18 x 9.50-11 CXT (DIED NR 1183) WHEEL
WINCH (HYDRAULIC)	MODEL FM 4000 SUPERWINCH
HYDRAULIC JACKS	BASED ON STANDARD HYDRAULIC CYLINDER (TEUS HYDRAULICS, INC. OR EQUAL)
BATTERY TYPE (12VOLT)	SAE NR 18M1

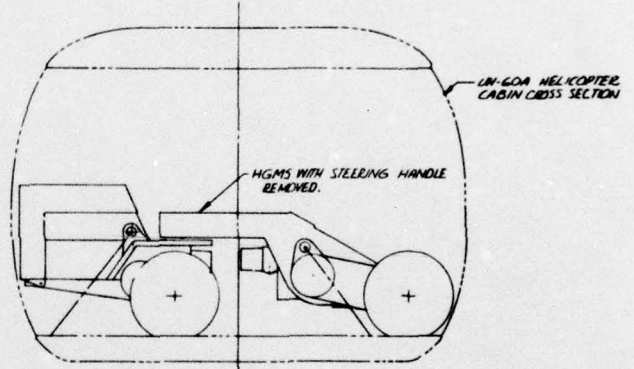

HGMS RIGGED FOR AIRLIFT IN UH-60A

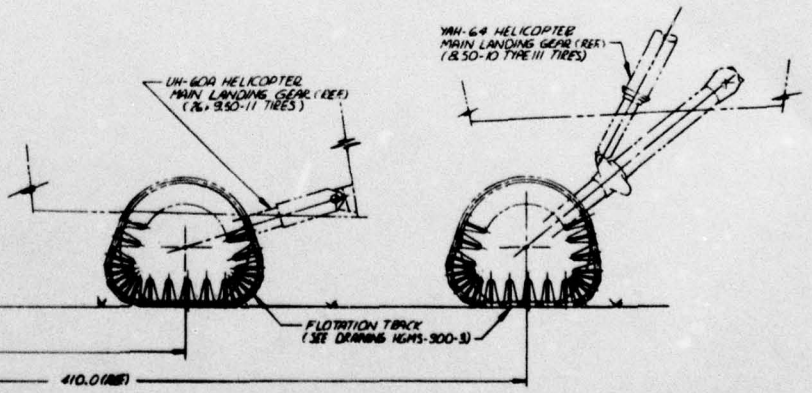

TABLE 3. ENGINE CANDIDATES

MFR	MODEL TYPE	RATING		PK. TORQUE FT-LB	HT	LGTH	WIDTH	NGT	REMARKS
		HP	RPM						
ONAN	CCKB-MS 2CYL-H.O.	20	3900	51.2	22.10	15.04	19.50	159	HT-20.3 W/MANUAL STARTER
	CCKB(SR) VEHICULAR			2500	19.88	20.62	25.56		DESIGNED SPECIFICALLY FOR VEHICULAR & TRACTOR USAGE.
PETTER	AC 2 2CYL-INT.	19.2	3600	20	19.0	21.85	20.25	172	8 NOT INCLUDING PTO SHAFT. INCL 10.8 PT FUEL TANK. OPT. ELEC. ST.
	K662S 2CYL-H.O.	24	3200	44.5	28.5	22.44	23.15	286	HI-STANDING CAB & AX. HT COULD BE REDUCED TO 3' 10.5" W/HORR. DEFT CAB.
KOHLER	K582S 2CYL-H.O.	23	3600	40.8	19.25*	18.94	20.5	187	
	VH4D 4CYL-V	30	2800	65.8	22.06	25.98	21.5	335	NGT INCLUDES 25 LB FOR FLYWHEEL ALTERNATOR - DIMS DO NOT INCLUDE AX
TELEDYNE WISCONSIN	TJD 2CYL	18	3600	34.4	27.5	22.81	19.25	240	NGT INCLUDES 20 LB FOR FLYWHEEL ALTERNATOR
	# 790 2CYL	30	3000	57.3	25.88	28.44	17.64	356	INCLUDES FUEL TANK. DIMENS MAY BE REDUCED IF REMOVED.
BRIGGS & STRATTON	400410 2CYL-H.O.	16	3600	25.8	17.75	16.0	17.81	87	DIMENS * NGT INCLUDES ELECT START & DUAL CIRCUIT ALTERNATOR, FUEL PUMP
	326430 1CYL	16	3600	25.8	21.09	15.62	24.62	106.5	INCLUDES 60 PT FUEL TANK - ROPE START w/O ALTERNATOR
CONTINENTAL	4084 4CYL-H.O.	34	3150	60	22.12	24.5	28.0	205	MILITARY STANDARD ENGINE
AVCO	M-42 2CYL-V	20	3000	40.5	26.88*	20.03	28.75	397	INCLUDES FUEL TANK, ELECTRIC STARTER & GENERATOR
	M-44 4CYL-V	40	3000	82	26.88*	27.40	29.53	458	INCLUDES FUEL TANK, ELECTRIC STARTER & GENERATOR
TECUMSEH	OH160 1CYL	16	3600	25	18.5	17.25	15.56	95	NO FUEL TANK - SMALL MUFFLER OVER PTO SHAFT.
PETTER	B42 2CYL-INT.	22	3000	2800	25.35	23.25	19.45	324	CLEANK START. NO ELECTRICS DE FUEL TANK INCLUDED.

* ESTIMATED REDUCED HEIGHT W/ COMPONENTS RELOCATED. ● DIESEL ENGINE

PREVIOUS PAGE BLANK - NOT FILLED

arrester/muffler; engine availability and maintainability; and cost in addition to purely performance characteristics.

The selected engine, the Briggs and Stratton Series 400410, offers adequate power at the lowest installed weight and includes an integral electric starter-alternator. The engine's small physical size minimizes installation problems and eliminates the need to reposition or repackage engine components. Although only recently entering production, this engine is representative of proven technology and has ample parts and service support.

A hydrostatic transmission system was selected because it offers full performance in either direction with simple controls and a minimum of mechanical complexity in the installation. The choice of specific components, pumps and motors, was predicated on achieving the necessary performance with the lowest practical system working pressure and a minimum of mechanical reductions. The Sundstrand Series 15 tandem pump meets these requirements with a single pumping unit which requires only one mounting and one drive. The unit provides two independent pumping systems and includes integral charge pumps and the necessary circuit valving and pressure reliefs. Like the engine, the Sundstrand unit is highly reliable, commercially available, and representative of the latest in the state-of-the-art. The Webster Model MC5F-15 hydraulic motors selected are compatible with the pumps and, by virtue of their 1.30 cubic inch displacement, contribute to the overall gear reduction. The Dana Spicer Model GT-20 axle is designed specifically for use with a hydrostatic transmission and incorporates an integral input reduction gearbox giving an overall ratio of 20.9:1. This axle, unlike others investigated, incorporates rugged, automotive-quality components, in a lightweight aluminum housing. Roller chain final drives, with reduction ratios of 1.57:1.0,

serve as trailing arms which connect the 18 x 9.50-8 Goodyear Terra-Tires and wheels to the axle output shafts. The chassis structure which supports the axle housing and tubes also provides mountings for the engine and pump unit, telescopic control/steering handle, and the trailing unit attachment. The engine is offset to the right at the forward end of the unit. A timing belt drive, with a 1:1, ratio drives the Sundstrand Series 15 tandem pump assembly, mounted to the left of the engine, which is the input end of the hydrostatic transmission. The pumping unit is mounted parallel to the engine crankshaft and provides independently controllable, closed-loop hydraulic flow to the hydraulic motor at each axle input. Pump outputs are controlled from twist grips on the control/steering handle and provide equal performance in both forward and reverse directions of travel. Excess flow from the charge pumps integral with the Sundstrand pumping unit are used to operate the hydraulic lifting jacks on the load platform.

The engine is governed to drive the pumps at a constant 3,000 rpm. The variable displacement Series 15 pumps, with a displacement range of from 0 to .913 cubic inches per revolution in either direction, produce a maximum output of 11.9 gpm per pump. This flow, when delivered to the hydraulic motor (1.3 cubic inches per revolution), with the selected tire, produces a ground speed of 3 mph in either direction. The tractive effort (four-wheel drive) necessary to climb a 15-percent grade is developed at a system pressure differential of 2,860 psi. At this pressure, the available engine power can achieve a vehicle speed of approximately 0.9 mph. The engine incorporates an electric starter and alternator and can also provide 3 amperes of electrical current at 12 VDC for battery charging as well as an additional 100 watts for operation of other electrical equipment and the loading winch. The winch control is grouped with those for the jacks on the control/steering handle.

The control/steering handle assembly, shown in Figure 25, is telescopic and may be adjusted to provide for comfortable and effective use by operators in the 5th to 95th percentile anthropometric range per MIL-STD 1472B. The travel speed and direction of the HGMS are controlled by a twist grip which functions naturally with the operator facing in the direction of travel. Release of the control by the operator will result in the transmission returning automatically to the neutral position.

All operating systems are adequately covered by sheet-metal enclosures which provide environmental protection for the equipment while also safeguarding the operator from injury. The tires are covered by fenders which protect the operator from material thrown up by the wheels during reverse operation.

The rear, or load, unit is essentially a scoop-shaped load platform mounted on wheels. The wheels are mounted on trailing arms which house the 1.57:1.0 ratio chain drives connecting the wheels to the axle unit as described above. The arms are arranged to rotate about the axle shaft centerline, permitting the load platform to be raised or lowered by the two 2500-pound capacity hydraulic jacks attached to the platform. The arms are locked to the platform in the "up" position by pins which must be withdrawn prior to lowering the platform. An electric 4000-pound capacity winch is mounted above the axle gearbox and is used to pull the helicopter tail wheel onto the lowered platform. The rear unit structure incorporates the attachment fittings for the Skid-Equipped Helicopter Adapter unit which is discussed in Section 4.2.

When used to move the wheel-equipped AAH or UTTAS helicopters, the power module is complemented by a pair of flotation tracks which are fitted loosely around each of the aircraft main

- ① TWIST GRIP: SPEED FORWARD; REVERSE
- ② BAR POSITION: 95% MAN
- ③ BAR POSITION: 5% MAN
- ④ STOWED BAR POSITION
- ⑤ JACK AND WINCH CONTROLS

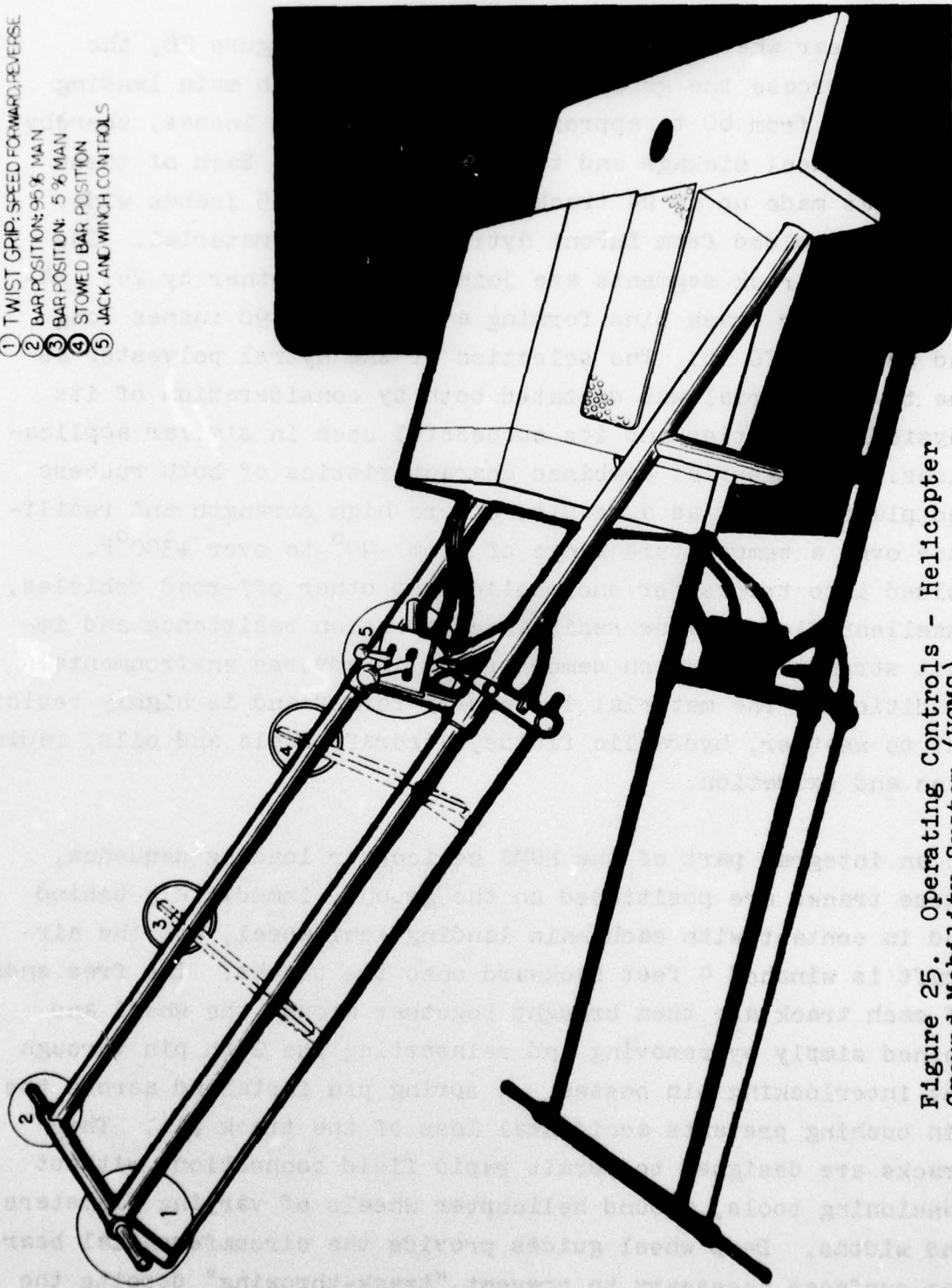

Figure 25. Operating Controls - Helicopter
Ground Mobility System (HGMS)

landing gear wheels. As shown in detail in Figure 26, the tracks increase the ground contact area of each main landing gear wheel from 60 to approximately 250 square inches, thereby reducing wheel sinkage and towing resistance. Each of these tracks is made up of 24 track segments, each 15 inches wide, which are molded from DuPont Hytrel polyester material. The individual track segments are joined to each other by 24, 1/4-inch diameter track pins forming a flat track 90 inches long and weighing 70 lb. The selection of the Hytrel polyester as the track material was dictated both by consideration of its physical properties and its successful uses in similar applications. The material combines characteristics of both rubbers and plastics and, as a result, offers high strength and resilience over a temperature range of from -90° to over +300°F. Molded into tracks for snowmobiles and other off-road vehicles, excellent flex-fatigue resistance, abrasion resistance and impact strength have been demonstrated in adverse environmental conditions. The material is readily formed and is highly resistant to weather, hydraulic fluids, aircraft fuels and oils, radiation and oxidation.

As an integral part of the HGMS helicopter loading sequence, these tracks are positioned on the ground, immediately behind and in contact with each main landing gear wheel, and the aircraft is winched 4 feet backward onto the tracks. The free ends of each track are then brought together around the wheel and joined simply by removing and reinserting the 24th pin through the interlocking pin bosses. A spring pin installed across the pin bushing prevents accidental loss of the track pin. The tracks are designed to permit rapid field connection, without tensioning tools, around helicopter wheels of varying diameters and widths. Deep wheel guides provide the circumferential bearing surfaces necessary to prevent "track-throwing" despite the typically loose track-to-wheel fit. As the wheel rolls inside

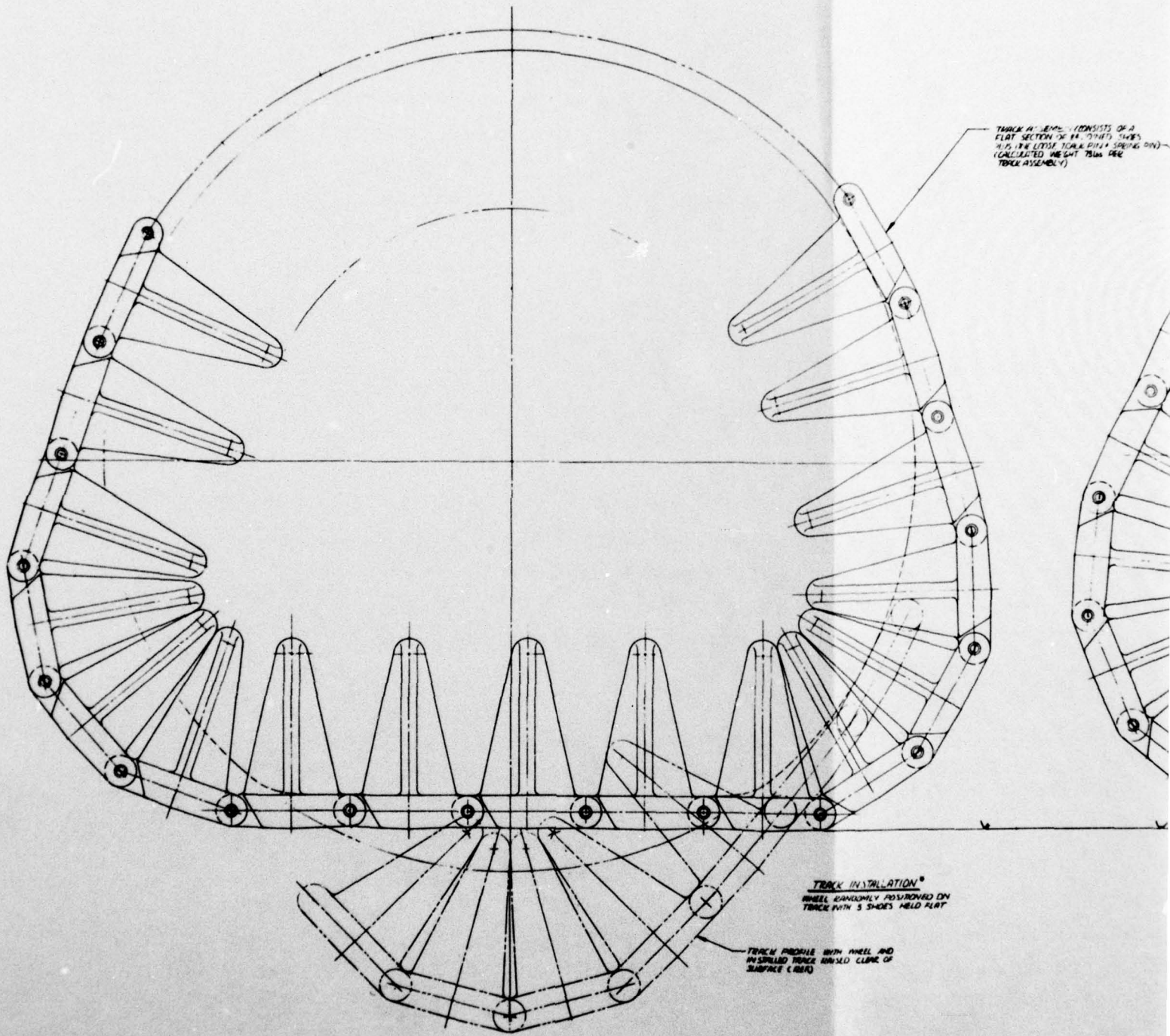
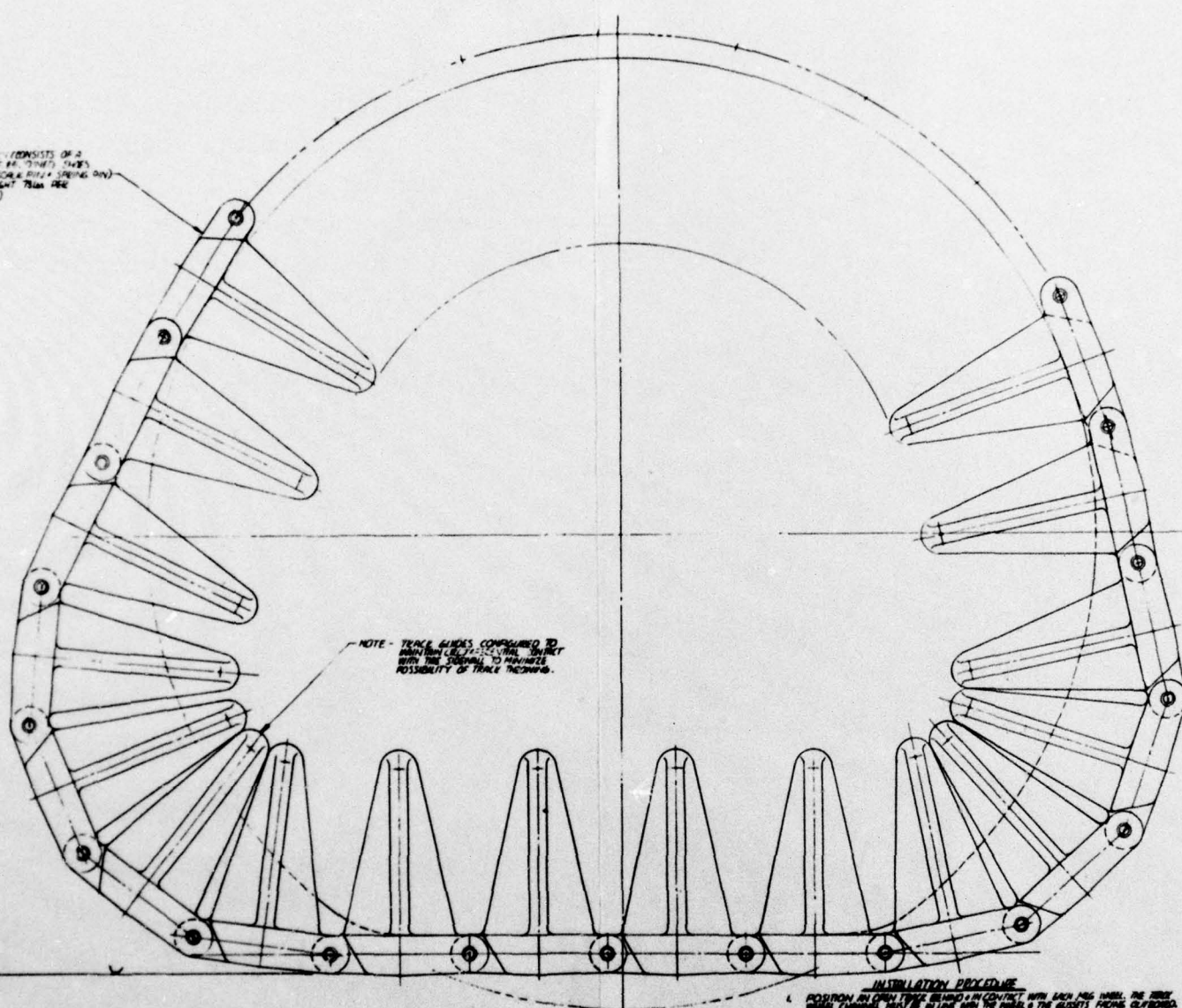

Figure 26. Flotation Track Installation - Helicopter Ground Mobility System (HGMS)

WHEEL ASSEMBLY (CONSISTS OF A
 3/4" SECTION OF 1/2" DIA. SHAFT
 1/2" DIA. LITTLE TOOTH ROLLER SPRING PIN)
 BELIEVED WEIGHT FROM THE
 WHEEL ASSEMBLY



NOTE - TRACK GUIDES COMPARED TO
 MOUNTAIN RAIL TRACKS. CONTACT
 WITH THE SPRING TO MINIMIZE
 POSSIBILITY OF TRACK TIPPING.

*NOTE - BASED ON AN 11-1/2" DIA. JOINTED
 CONTACT LENGTH OF 6.5" TRACK.
 WITHIN THE BROAD CONTACT
 AREA OF EACH ROLLER A TRACK
 UNIT BELONGS APPROPRIATELY
 200 SOME INCHES.

TRACK INSTALLATION
 WHEEL ORIGINALLY POSITIONED ON
 TRACK WITH LABEL AND FLAG

- INSTALLATION PROCEDURE**
1. POSITION AN OPEN TRACK BEHIND IN CONTACT WITH EACH WHEEL. THE TRACK CHANNEL MUST BE IN LINE WITH THE WHEEL & THE SLIGHTLY FACING OUTWARD.
 2. PUSH THE WHEELS FORWARD INTO THE TRACKS UNTIL TO LEADING EDGE OF TRACK IS IN CONTACT WITH THE TRACK'S CENTER (1/2" DIA.) OF TRACK IS POSITIONED IN FRONT OF EACH WHEEL.
 3. OPEN THE FORWARD END OF ONE TRACK. BACK UP AND COVER THE LEADS END AND FORWARD AND ALIGNMENT WITH THE FORWARD END.
 4. OPEN THE TRACK END BY ACCEPTING THE LEADER TRACK PIN THROUGH THE WHEEL CENTER. THE PIN IS A LIGHT WIRELESS. IT SHOULD BE FIRSTLY SHARP THE PIN DOWN THE TRACK AND A 1/2" DIA. PIN DOWN THE TRACK. THE PIN IS PLACED BY HOLDING THE TRACK AND PIN. THE PIN IS DOWN THE TRACK. THE PIN IS WITH THE TRACK END OF THE TRACK.
 5. REMOVE STRIPS 24" WITH THE BRIDGE TRACK.
 6. TO REMOVE THE TRACK, REMOVE STRIPS 24". ANY CONVENIENT TRACK PIN MAY BE REMOVED. USE THE PIN PINCH TO REMOVE SPRING PIN & JES OR PIN PINCH TO GRAB THE TRACK PIN.



2

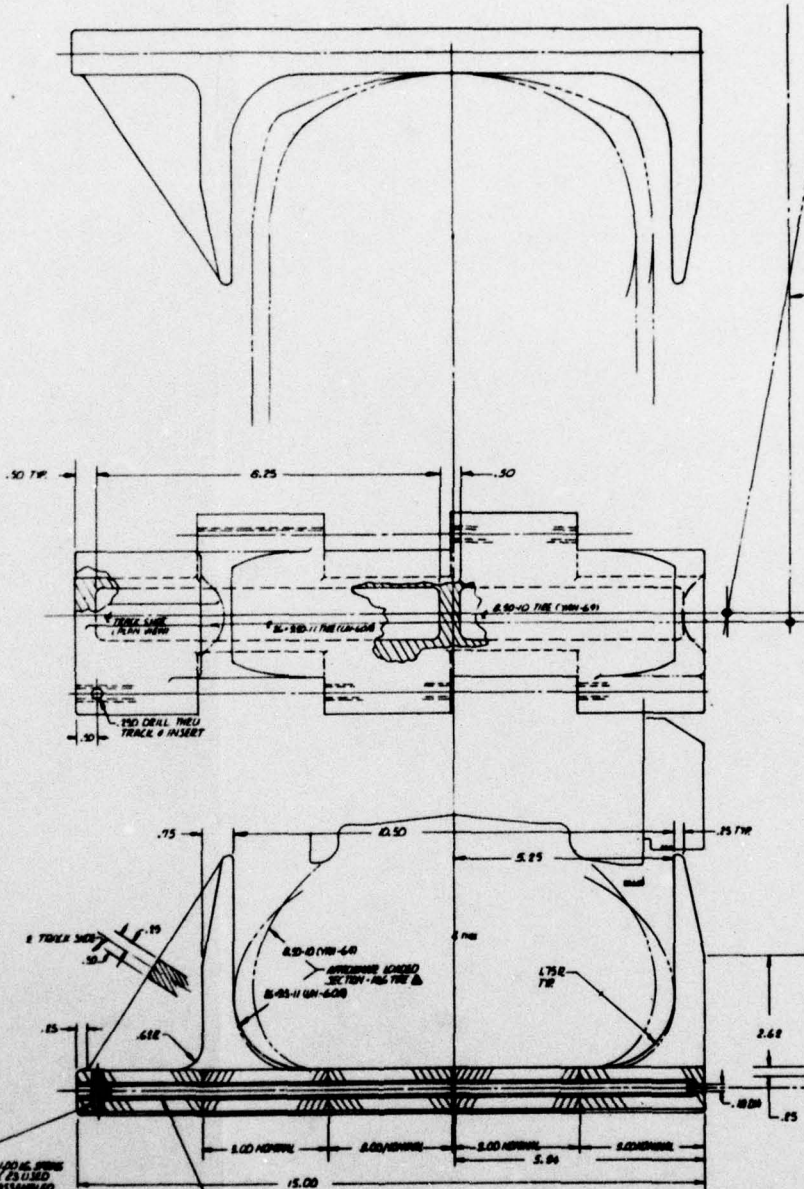
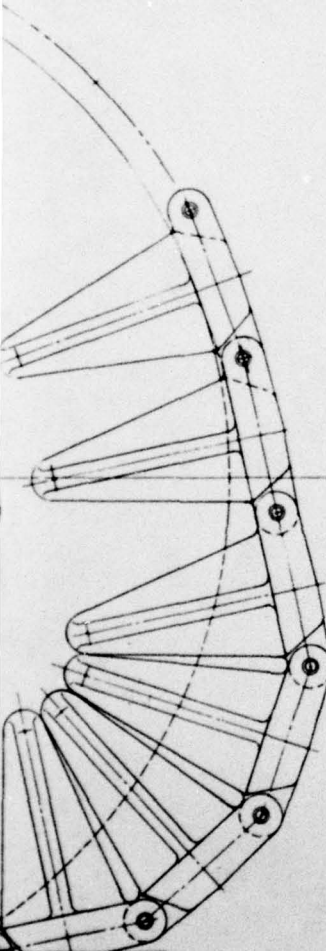

NOTES:

1. TRACK SHOES MOLDED BY W. R. TEELE & CO. INC. 15-35 SLACK DUPONT NYLON POLYESTER ELASTOMER WITH STEEL BUSHING INSERTS.
2. DEPLETED TIRE GEOMETRY AND FOOTPRINT DIMENSIONS CALCULATED FROM MANUFACTURER'S HANDBOOK DATA AND MATERIAL CONTAINED IN NATIONAL BUREAU OF STANDARDS MONOGRAPH 172- MECHANICS OF PNEUMATIC TIRES.
3. TRACK SHOE PITCH AND TRACK LENGTH DESIGNED TO PERMIT FIELD ASSEMBLY AROUND WHEEL RADIUSLY POSITIONED ON TRACK WITH 3/4" TRACK TENSIONING TACKS.

INSTALLATION PRECAUTIONS:

1. TRACK SHOES TO BE INSTALLED WITH EACH PIVOT HUB. THE HOLES IN THE TRACK SHOES MUST BE ALIGNED WITH THE HOLES IN THE PIVOT HUBS. THE TRACK SHOES MUST BE INSTALLED ON THE PIVOT HUBS IN THE ORDER SHOWN IN THE DRAWING. THE TRACK SHOES MUST BE INSTALLED ON THE PIVOT HUBS IN THE ORDER SHOWN IN THE DRAWING. THE TRACK SHOES MUST BE INSTALLED ON THE PIVOT HUBS IN THE ORDER SHOWN IN THE DRAWING.

3/16" DIA. TACKS ARE USED AT PIVOT POINTS TO PERMIT SLIPPERY LOADS FOR FIELD-ASSEMBLY JOINTS.

3/16" DIA. TACKS ARE USED AT PIVOT POINTS TO PERMIT SLIPPERY LOADS FOR FIELD-ASSEMBLY JOINTS.

78

of the track the wheel load will be transferred alternately to four or five track sections in contact with the ground. The track pitch, 3.75 inches, and track length eliminate any requirement to precisely position the wheel with respect to track length in order to connect the ends. Similarly, the track may be taken apart at any convenient point, for removal from the wheel, by removing any one of the 24 identical track segment-connecting pins.

4.2 SKID-EQUIPPED HELICOPTER ADAPTER

The Skid-Equipped Helicopter Adapter shown in Figure 27 evolved from a series of concepts. Initially it appeared that the major differences in physical size and weight between the two large helicopters (UH-1 and AH-1) and the two light helicopters (OH-6A and OH-58A) now in the inventory precluded the design of a single, universally useful, adapter. As a consequence, the first concept studied was a frame-type semi-trailer designed to pick up and carry the UH-1 and AH-1 helicopters. Basic to this concept was the use of the standard helicopter ground handling wheel attachment fittings as the interface between helicopter and adapter. The concept incorporated tandem-mounted Terra-Tires and an integral jacking system. A gooseneck fitting provided a towing attachment to the HGMS power module described in Section 4.1.

The second concept, configured for the OH-6A and OH-58A helicopters, envisioned that the helicopter would "fly on" and "fly off" the adapter. It was essentially a deckless, four-wheeled trailer with a towbar and front-wheel steering mechanism. The longitudinal frame members consisted of channel-like treadways on which the helicopter could be landed. The running gear utilized 20 x 14.00 Terra-Tires and incorporated a jacking system which permitted the treadway/platform to be lowered into firm, level ground contact for flight operations. The raised adapter

could be towed by any vehicle organic to aviation units and fitted with a towing pintle, as well as by the HGMS power module.

A review of the two concepts described above indicated that the first concept could be configured to handle all four helicopters. A third design concept incorporating these modifications was prepared. In addition, the suspension unit design was changed to permit the adapter to be used to load a UH-1 helicopter into the C-130 or C-141 aircraft for air transport. This latter capability was achieved by removing the tandem-mounted wheel/walking beam units from the outboard sides of the adapter frames (loading position) and reinstalling them inboard of the frames, thereby achieving the necessary reduction in overall width. An additional concept incorporating all of the principal features noted evaluated the use of dual-wheel suspension units which could be swung into position for loading on cargo aircraft, eliminating the need to remove and reinstall wheel units.

The fifth exploratory concept design was predicated on the desire to achieve the minimum possible weight for an adapter capable of handling all four helicopters models. This concept featured an adjustable-width main frame whose side members passed under the fuselage rather than outboard of the skids. The concept also used single wheels and screw jacks assembled into a rear support/wheel unit.

The five concepts described were evaluated in the context of the basic requirements to provide an effective means of moving current inventory skid-equipped helicopters in conjunction with the HGMS equipment and personnel. This review resulted in the concept shown in Figure 27 which combines the most compatible features of the five concepts. This final concept utilizes the ground handling wheel attachment fittings on the skids as the

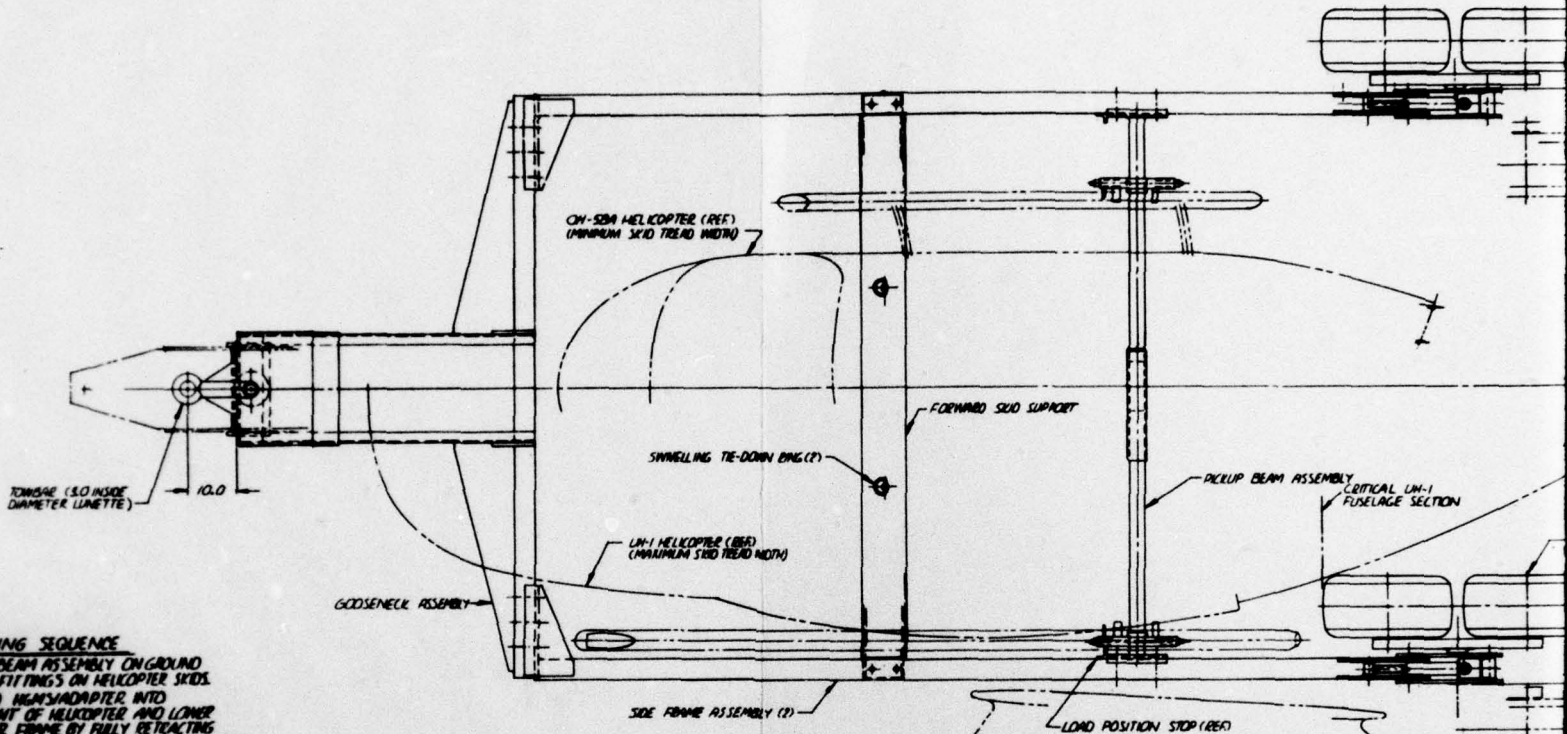

LOADING SEQUENCE
 PICKUP BEAM ASSEMBLY ON GROUND TO GEAR FITTINGS ON HELICOPTER SKIDS.
 ASSEMBLED HGM/ADAPTER INTO 1 IN FRONT OF HELICOPTER AND LOWER ADAPTER FRAME BY FULLY RETRACTING EYES ON WALKING BEAM / ANCEL ASSEMBLIES.
 ADAPTER UNTIL LOAD POSITION STOPS AT PICKUP BEAM END ATTACHMENT FLANGES.
 END PICKUP BEAM UNTIL ATTACHMENT'S CONTACT ADAPTER SIDE FRAMES.
 ADAPTER AS NECESSARY WITH JACK SCREWS (LURE PICKUP BEAM FLANGES TO SIDE FRAMES) BALL LOCK PINS. ELEVATE ADAPTER TO ANY HEIGHT BY FULLY EXTENDING JACK (WHEN HELICOPTER WILL ASSUME A DOWN ATTITUDE).
 UP ON HELICOPTER WAS SKID TO POSITION OF HELICOPTER IN A SUITABLE ANGLE OF ATTITUDE.
 IN FORWARD SKID SUPPORT UNDER SEATS AND BRINE WALKER PINS. LOWER HELICOPTER SKIDS ON TO SUPPORT.
 TIE-DOWN STRAPS TO FORWARD HOISTING FITTINGS TOP OF HELICOPTER AND THE HELICOPTER IS READY FOR TO MOVEMENT.

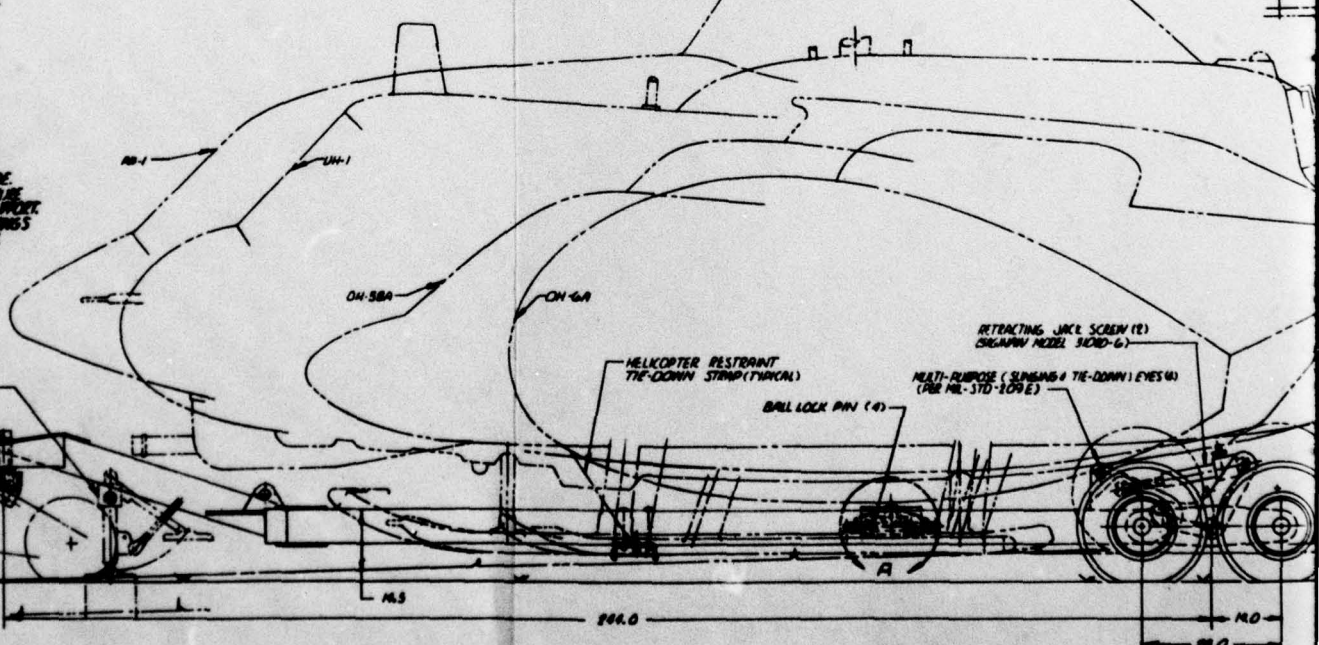

2

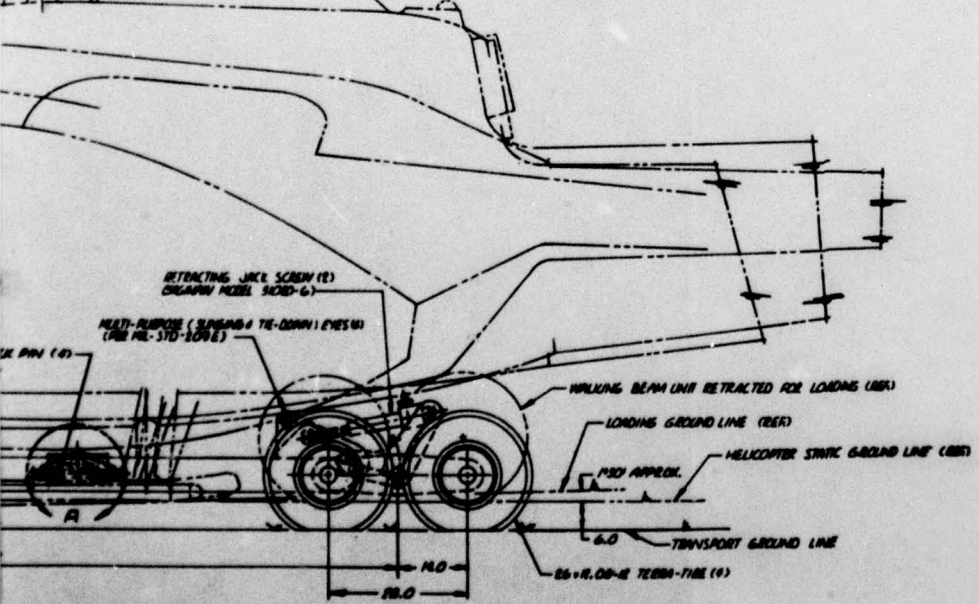
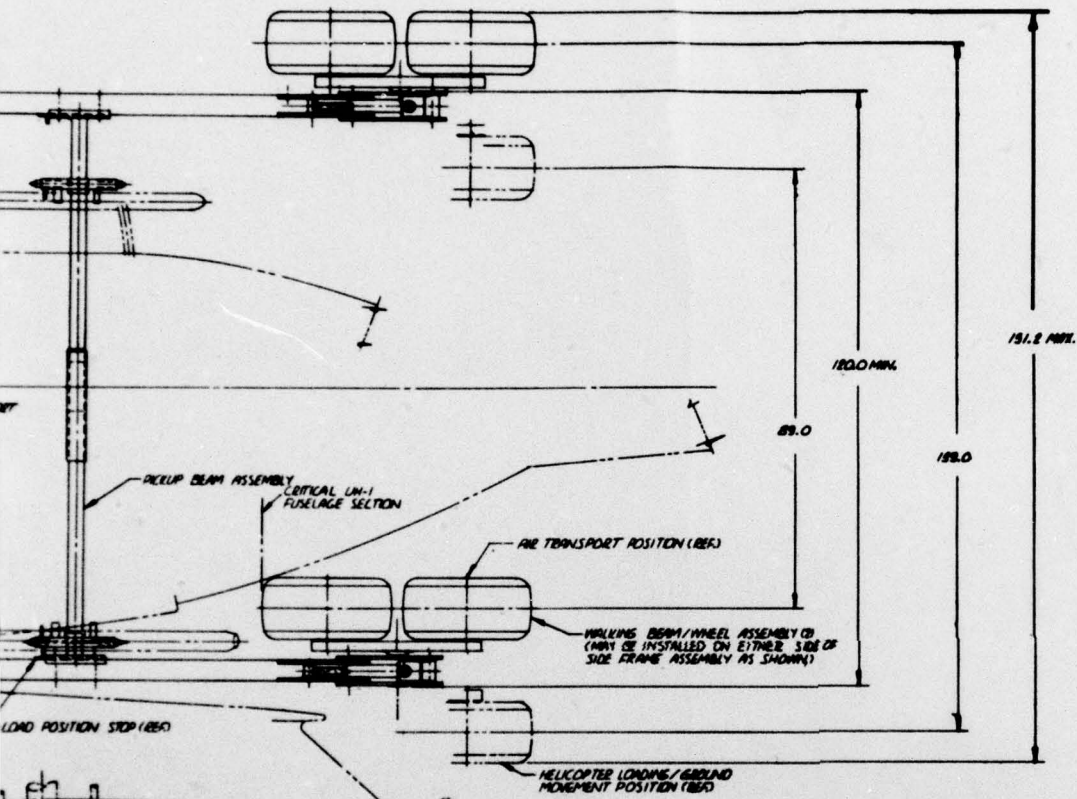

5

pickup point, but provides adequate structure to minimize the possibility of overloading and consequent damage to the skids and the helicopter.

The adapter frame consists of a pair of side frame assemblies bolted to the forward gooseneck assembly. The ends of the side frames each carry a suspension unit consisting of two 26 x 12.00-12 Goodyear Terra-Tires and wheels mounted on a walking beam. The walking beam may be attached to either side of a bellcrank linkage which also incorporates a screw-jack member. The jack is used to raise or lower the end of the frame with respect to the ground line on which the adapter wheels are resting. The side frames are connected transversely near their midpoints by the forward skid support. The gooseneck assembly which bolts to the side frames is fitted with both a towing lunette and an attachment fitting to mate with the HGMS power module. An optional jack screw/support may also be provided to facilitate attachment to the prime mover. The telescoping tubular pickup beam assembly incorporates hanger units at each end which lock onto the standard attachment fittings on the skids of any of the four helicopter models. The hanger units are arranged to rotate and slide laterally on the reduced diameter section of the tubular beam. This lateral freedom is provided to permit the same beam to accommodate skid treadwidths ranging from the nominal 74.4 inches of the OH-58A to the 102 inch maximum allowed on the UH-1. The beam ends incorporate angle-shaped flanges which mate with holes in the side frames. The side frames also provide positive stops which serve to automatically align the flange holes with those in the frame. The use of aluminum for major structural elements permits a basic adapter weight of approximately 1100 pounds.

The loading sequence for the adapter consists of several steps. First, the pickup beam is passed under the helicopter and secured and locked to the skid fittings on the helicopter. Next,

the adapter frame, with wheels in the outboard position and the frame lowered, is positioned in front of, and centered on, the helicopter. The adapter is moved backward until the load position stops on the HGMS adapter side frames contact the end flanges of the pickup beam. The beam is then extended fully and the adapter frame raised as required to permit installation of the ball-lock pins which secure the beam to the frame. The suspension jack screws are then extended fully, raising the frame to transport height and causing the helicopter to assume a nose-down attitude. Using sufficient load applied to the helicopter tail skid to position and hold the helicopter in a slightly nose-up attitude, the forward skid support is positioned below the landing skids and secured with ball-lock pins. The helicopter is then lowered until the skids rest on the forward skid support and is further secured by attaching tiedown straps.

The helicopter is unloaded by reversing the loading sequence. If the loaded helicopter is to be air transported it is necessary to move the wheel/walking beam units to the inboard position. This is accomplished by retracting the jack screws to lower the frame ends onto blocks, thus unloading the wheels so they may be easily removed and reinstalled. The wheel assemblies must, however, be returned to the outboard position before the helicopter can be unloaded from the adapter.

Although not shown in Figure 27, the adapter may be fitted with deck panels to also permit its use as an effective, easily loaded, low-bed utility trailer, towable by a variety of vehicles organic to aviation units.

5.

CONCLUSIONS AND RECOMMENDATIONS

The concept design and feasibility investigation documented in this report clearly demonstrates the technical, operational, and economic feasibility of a ground movement system configured to provide local mobility for the AAH and UTTAS helicopters. Additionally, the engineering and design efforts of the latter part of the study produced a practical configuration for an adapter to enable use of the wheeled-helicopter ground movement system (HGMS) as a means of locally moving the Army's current inventory skid-equipped helicopters.

The contractor's concept formulation activities resulted in the development of some 30 different approaches to providing the tractive effort and flotation required to move the YAH-64 AAH and UH-60A UTTAS helicopters across the unimproved terrain described in the report, and to accomplish such movement within a cycle time of no more than 6.7 minutes so that five helicopters could be moved between a landing area and concealed positions within 39 minutes, including HGMS movement time between helicopters. The concepts investigated included wheeled and tracked, self-propelled and towed, and frame-type as well as auxiliary flotation and auxiliary power ground movement systems.

These concepts were subjected to a comprehensive three-step evaluation to determine mission suitability. The concept ultimately selected for further development and prototype design in a direct comparison with the four other concepts that survived the first two evaluation steps, and as measured against an average or "optimized" design, demonstrated its overall superiority on a cost benefit basis on 13 critical rating points. These points included mobility, speed, maneuverability, gradeability, weight, tractive effort, power/weight ratio, and air transportability. The selected HGMS concept can handle the wheeled AAH

and UTTAS helicopters and, with the adapter device shown in Figure 27, will also accommodate the Army's current inventory skid-equipped helicopters.

It must be recognized that the selected concept is a highly specialized system, especially adapted to the mobility requirements specified in the contract and defined in this report and particularly adapted to the military environment in which it and the noted helicopters will be operating. Furthermore, while it may be considered the major element, the prime mover is only a part of the total HGMS system. It supplies tractive effort, but cannot, by itself, perform the ground mobility mission. The track assemblies for the main landing gear of the wheeled AAH and UTTAS helicopters, and the adapter for the skid-equipped helicopters, provide the second essential for ground mobility - soft terrain flotation.

Considering the foregoing, it is evident that the typical commercial light aircraft or helicopter ground mobility equipment (for example, small tugs or wheel power units designed to operate on improved surfaces) could not be expected to perform the HGMS mission. They cannot satisfy the Army mobility requirement, and they do not possess the reliability and durability needed to survive and perform dependably in a military environment.

To gain the maximum benefit from the HGMS concept formulation and feasibility investigation documented in this report, VSDC recommends that the Army proceed with its plans to prototype the selected HGMS concept and the skid-equipped helicopter adapter. The design and analytical work which has been accomplished provides a high level of confidence in the functional capability of the system, and the near-term availability of prototypes will afford an opportunity, in field trials, to

develop effective operational techniques for its use that will justify placing it in service. Based on a knowledge of the operational demands that will be made on Army aviation units in the next decade, it is clear that employment of the HGMS could measurably enhance the survivability of attack and utility helicopters in forward areas and thereby increase their combat effectiveness.

REFERENCES

1. HELICOPTER MOVEMENT ON UNIMPROVED TERRAIN, USAEWES
Technical Report M-74-1, U.S. Army Aviation Systems
Command/U.S. Army Engineer Waterways Experiment Station,
Vicksburg, Mississippi, January 1974.
2. EXPEDIENT MEANS FOR MOVING HELICOPTERS, USALWL Technical
Report 74-75, U.S. Army Land Warfare Laboratory, Aberdeen
Proving Ground, Maryland, April 1974.
3. HELICOPTER GROUND MOVEMENT SYSTEM TEST, MASSTER Test
Report FM 161, Headquarters, Modern Army Selected
System Test, Evaluation, and Review, Fort Hood, Texas,
March 1973.

BIBLIOGRAPHY

1. AIRCRAFT FLOTATION CONCEPTS STUDY - AIRCRAFT MOVER VEHICLES, AFWL Test Report 71-172, Air Force Weapons Laboratory, Kirtland Air Force Base, New Mexico, March 1972.
2. ENGINEERING DESIGN HANDBOOK - HELICOPTER ENGINEERING, PART ONE, PRELIMINARY DESIGN, AMCP Pamphlet 706-201, Headquarters, U.S. Army Materiel Command, Washington, D.C. August 1974.
3. ENGINEERING DESIGN HANDBOOK - SYSTEMS ANALYSIS AND COST-EFFECTIVENESS, AMCP Pamphlet 706-191, Headquarters, U.S. Army Materiel Command, Washington, D.C., April 1971.
4. EVALUATION OF SOIL STRENGTH OF UNSURFACED FORWARD-AREA AIRFIELDS BY USE OF GROUND VEHICLES, USAEWES Paper No. S-70-14, U.S. Army Engineer Waterways Experiment Station, Vicksburg, Mississippi, May 1970.
5. REFERENCE DATA FOR ARMY AVIATION, U.S. Army Special Text ST 1-100-1, U.S. Army Aviation School, Fort Rucker, Alabama, May 1973.
6. SYSTEMS FOR TRANSPORTING AIRCRAFT ON THE GROUND, FAA Report RD-74-92, U.S. Department of Transportation - FAA, Washington, D.C., December 1973.

APPENDIX A

VCI PROCEDURE, MOTION RESISTANCE, AND POWER REQUIREMENTS

APPLICATION OF VCI PROCEDURE TO HGMS

The Vehicle Cone Index (VCI) designator system developed by USAEWES (see reference 1) provides an estimate of vehicle "go" or "no-go" capability in a soil characterized by a Rating Cone Index (RCI).

USAEWES has experimentally determined VCI values for a large number of vehicles, both wheeled and track-laying, and vehicle-trailer combinations. Based on field measurements, USAEWES has also formulated a set of equations which can be used to calculate the VCI of a vehicle of more or less conventional configuration, based on consideration of certain vehicle characteristics such as weight, ground clearance, wheel or track dimensions, and available power. Low numerical VCI values indicate greater mobility.

The equations are available for both wheeled and tracklaying vehicles and certain assumptions are implicit in their application. These are:

- The vehicle moves in straight, unaccelerated motion.
- Adequate torque is available.
- All wheels or tracks share the gross load equally.
- All wheels or tracks in contact with the ground are powered.

Application of these equations to vehicles which do not meet these requirements, or to vehicle-trailer combinations, can only be accomplished reliably through the integration of complex considerations which require much more detailed information than is available from the preliminary designs for the candidate HGMS concepts developed in the subject investigations. However, it is possible to calculate VCI values based

on the standard equations for use as comparative figures of merit for mobility, recognizing that the VCI values so obtained do not necessarily indicate the actual performance which can be expected.

The results of such calculations for the selected concepts are presented in Table A-1.

TABLE A-1. HGMS CONCEPT VEHICLE CONE INDEX (VCI_1)

<u>Concept No.</u>	<u>VCI_1</u>	<u>Concept No.</u>	<u>VCI_1</u>
1	51	10	24
2	45	11	25
6	43	13	21
9A	23	14	35
9B	24	15	25

In connection with these VCI figures, it should be noted that Concepts 1, 2, and 14, with the highest values, most nearly meet all the criteria for full use of the formula since they are self-propelled vehicles. These values should closely approximate the true mobility performance of the concepts. The others, with the exception of Concept 15, are wheeled vehicle-trailer combinations and are uniquely configured for low ground pressures and reduced motion resistance. Reference to the USAEWES listings of VCI values shows that the combination vehicles which have been tested exhibit VCI_1 values in a range from 21 to 35, with the lower values characteristic of low ground pressures. This correlation between conceptual VCI's and recorded VCI values confirms the validity of their use in the HGMS concept matrix analysis.

HGMS TRACTIVE EFFORT AND POWER REQUIREMENTS

The program work statement defined the HGMS performance goals in terms of speeds and the gradeability to be achieved on soils of a specified Cone Index (CI). Specifically, the requirements

state that the HGMS must, with a helicopter gross weight of 10,000 - 15,000 pounds, be capable of negotiating a 3-percent grade in soil with a one-pass CI of 50 and a 15-percent grade in soil with a CI of 125, and sustaining ground speeds of at least 1 and 3 mph on dry, level ground with one-pass CI's of 50 and 125, respectively.

These requirements provide a reasonable basis from which to develop a test to measure the adequacy of the HGMS performance. They do not, however, express the performance goals in terms of specific design criteria to which the HGMS may be designed. These criteria must be expressed in terms of the motion resistance which will be experienced and the tractive effort necessary to overcome that resistance. The latter value, and the requirements of grade and speed, permit the development of drive system criteria including the engine power, wheel size, and the intervening gear ratios.

The USAEWES Mobility and Environmental Systems Laboratory at Vicksburg, Mississippi (the originator of the Cone Index system for soil classification) has performed a study of the problems associated with the movement of helicopters on unimproved terrain. The study, sponsored by the U.S. Army Aviation Systems Command and reported in Reference 1 measured the towing resistance of tires proposed for the UTTAS and AAH helicopters in a variety of soil conditions. Table 4 of Reference 1 presents estimates of the towing resistance of the complete helicopter, which range from 12-percent to 152-percent of the gross weight (depending on tire sizes, tire pressures, and soil conditions). Two soil conditions, RCI's of 105 and 52, are presented in the table. Figure 42 of Reference 1 shows a plot of resistance as a function of RCI and also indicates the towing performance of several military vehicles.

The data presented in the USAEWES study treats the helicopter as a three-wheeled trailer towed by another vehicle. The chosen HGMS concept removes the tail wheel from contact with the soil surface and uses flotation devices on the main landing gear to reduce sinkage and consequently lower towing resistance.

A generalized system for quantifying both the motion resistance exhibited and the maximum tractive effort which may be developed by a vehicle, or vehicle combination, in terms of an "Excess Rating Cone Index (RCI_x)" is also presented briefly in Appendix A, Soil-Vehicle Models, to Reference 1 and in more detail elsewhere. The RCI_x is defined as the difference between the Rating Cone Index (RCI) of a given soil and the Vehicle Cone Index (VCI) of a given vehicle. The calculated single-pass Vehicle Cone Index (VCI_1) for the HGMS power module (including 2700 pounds of transferred load) is 23 based on the current USAEWES formula. Calculation of a VCI_1 of 35.5 for the helicopter, considered as a trailer, is also possible, but because of the complexity of applying the formulas involved, does not (in USAEWES' opinion) provide a valid or useful result.

The RCI_x system as published by USAEWES is applicable to self-propelled vehicles and/or self-propelled vehicles towing "inoperable powered vehicles", and does not include trailers or self-propelled vehicles with non-powered wheels. However, USAEWES has published lists of "measured" VCI data for a variety of vehicles, including tractor-trailer or combination vehicles similar to the proposed HGMS-helicopter combination. The list includes VCI_1 values in a range from 21 to 35 for combinations designed for off-road service. The lower values are associated with vehicles exhibiting low ground pressures. As a specific example, the military 2-1/2-ton M35A2 truck towing a 1-1/2-ton M105A2 trailer (gross weight in excess of 25,000 pounds) has a

VCI₁ of 34. The truck alone has a VCI₁ of 26 at a weight of 19,000 pounds.

Considering the substantially lower weight of the HGMS-helicopter combination, the previously noted calculated VCI₁ of 23 for the power module and the use of flotation tracks on the helicopter main landing gear, it appears that an estimated VCI₁ of 30 for the combination is realistic and conservative. Using this value, and assuming a gross combination weight of 16,500 pounds, applying the USAEWES system procedure produces the following figures:

$$RCI_x = RCI - VCI$$

$$RCI_{x50} = 50 - 30 = 20$$

$$RCI_{x125} = 125 - 30 = 95$$

From Figure A5 of Reference 1, the coefficients of towing resistance (the ratio of resistance to total weight) may be derived for the above values of RCI_x, and the corresponding motion resistance and required zero-grade tractive effort (TE) can be calculated:

$$RCI_{x50} = 20 = 0.134 \quad TE_{50} = 0.134 \times 16,500 = 2211 \text{ pounds}$$

$$RCI_{x125} = 95 = 0.068 \quad TE_{125} = 0.068 \times 16,500 = 1122 \text{ pounds}$$

The excess tractive effort (TE_s) required for the grade performance specified for the HGMS is equal to the product of the percentage of grade and the gross weight of the combination of the HGMS and helicopter payload:

$$TE_s = 0.03 \times 16,500 = 495 \text{ pounds}$$

$$TE_s = 0.15 \times 16,500 = 2475 \text{ pounds}$$

The total tractive effort (TE) required by the HGMS to achieve the performance specified for the HGMS-helicopter combination is equal to the sum of the tractive effort necessary to overcome motion resistance and the tractive effort needed for grade-ability:

$$TE_{50T} = 2211 + 495 = 2706 \text{ pounds}$$

$$TE_{125T} = 1122 + 2475 = 3597 \text{ pounds}$$

With these values established, an initial determination may be made of the engine power required for the HGMS. Assuming that the maximum speed of 3 mph on soil with a one-pass CI of 125 is to be achieved on level ground, then the nominal engine power needed would be the following:

$$Hp = \frac{\text{Motion Resistance} \times \text{Velocity}}{375}$$

$$Hp = \frac{1122 \text{ pounds} \times 3 \text{ mph}}{375} = 9 \text{ Hp}$$

The engine selected for the preliminary design of the HGMS will produce 16 hp at 3600 rpm under standard conditions. Even with the engine power reduced to account for a density altitude of 10,000 feet and guaranteed minimum production engine performance, the available horsepower exceeds the above requirement. The HGMS maximum possible speed on the maximum grade of 15-percent may be determined as follows:

$$\text{Velocity (mph)} = \frac{(375 \times \text{hp})}{\text{Motion Resistance}}$$

$$\text{Velocity (mph)} = \frac{(375 \times 9)}{3597} = 0.9 \text{ mph}$$

Summarizing this cursory analysis, it demonstrates that the selected engine will enable the HGMS with its helicopter payload to attain the performance goals, speed and gradeability at a density altitude of 10,000 feet, specified for the system in the subject contract.