

AD-A047 532

AERONAUTICAL RESEARCH LABS MELBOURNE (AUSTRALIA)  
THE PERFORMANCE OF CONVENTIONAL AND ENERGY ABSORBING RESTRAINTS--ETC(U)  
SEP 75 S R SARRAILHE, N D HEARN

F/G 6/17

UNCLASSIFIED

ARL/STRUC. 359

NL

1 of 1  
AD  
AO47532

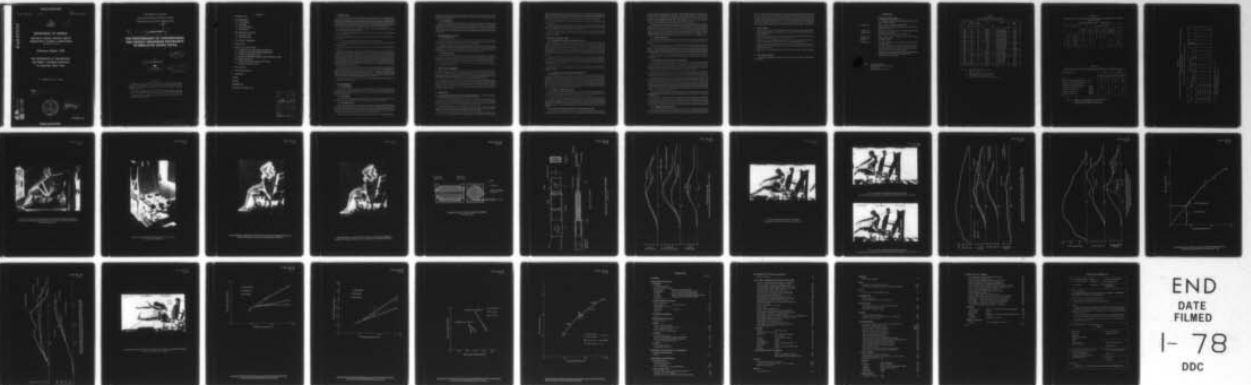

END  
DATE  
FILMED  
1-78  
DDC

UNCLASSIFIED

ARL/Struc. Report 359

ARL/Struc. Report 359



AD A 047532

DEPARTMENT OF DEFENCE

AUSTRALIAN DEFENCE SCIENTIFIC SERVICE  
AERONAUTICAL RESEARCH LABORATORIES  
MELBOURNE, VICTORIA

Structures Report 359

THE PERFORMANCE OF CONVENTIONAL  
AND ENERGY ABSORBING RESTRAINTS  
IN SIMULATED CRASH TESTS

by

S. R. SARRAILHE and N. D. HEARN

DISTRIBUTION STATEMENT A  
Approved for public release;  
Distribution Unlimited

DDC  
RECEIVED  
DEC 35 1977  
REGULATED  
A



AD No. \_\_\_\_\_  
DDC FILE COPY

SEPTEMBER 1975

UNCLASSIFIED

DEPARTMENT OF DEFENCE  
AUSTRALIAN DEFENCE SCIENTIFIC SERVICE  
AERONAUTICAL RESEARCH LABORATORIES

14 ARL / ~~STRUCTURES REPORT~~ 359

6 **THE PERFORMANCE OF CONVENTIONAL  
AND ENERGY ABSORBING RESTRAINTS  
IN SIMULATED CRASH TESTS,**

12 35 p.

by

10 S.R./SARRAILHE  
N.D./HEARN

11 Sep 75

SUMMARY

Dynamic tests were done using conventional lap sash seat belt restraints, and assemblies incorporating energy absorbers in the sash strap. Three restraint geometries, rigid and cushioned seats and assemblies with the straps slack, tight and preloaded were tested.

The load in the sash strap with an energy absorber was half of that in the same strap of a conventional restraint in tests with the same peak acceleration of 280 m/s<sup>2</sup>.

The results were also compared with those from previous tests where a shorter acceleration distance was used.

009650-

## CONTENTS

1. INTRODUCTION	3
2. TEST EQUIPMENT	3
2.1 Crash Simulator	3
2.2 Test Dummy	3
2.3 Test Frame and Seat	3
2.4 Instrumentation	4
3. THE RESTRAINT SYSTEMS	4
3.1 Four-point System	4
3.2 Three-point System	4
4. THE ENERGY ABSORBERS	4
5. PROCEDURE	4
6. RESULTS AND DISCUSSION	5
6.1 Comparison of Four-point and Three-point Systems	5
6.2 Comparison of Tests with Cushioned and Rigid Seats	5
6.3 The Effect of Tightening the Strap	5
6.4 The Effect of Sled Peak Acceleration on the Strap and Seat Loads	5
6.5 Dummy Displacement	6
6.6 The Effect of Energy Absorbers in the Sash Strap	6
6.7 Comparison with Previous Tests	6
7. CONCLUSIONS	7
8. ACKNOWLEDGEMENT	7
9. REFERENCES	8

### TABLES

### FIGURES

### DISTRIBUTION

### DOCUMENT CONTROL DATA

ACCESSION FOR	
KFIS	White Section <input checked="" type="checkbox"/>
DAC	Buff section <input type="checkbox"/>
UNCLASSIFIED	<input type="checkbox"/>
JUSTIFICATION	
<i>Letter on file</i>	
BY	
DISTRIBUTION AVAILABILITY CODES	
AVAIL	SPECIAL
A	

## 1. INTRODUCTION

Seat belts with upper torso restraint provide valuable protection for the occupants of an aircraft or motor vehicle in the event of a crash. The restraint forces in the conventional webbing system are clearly dependent on the vehicle deceleration, but the relationship is complex and may also depend on the velocity change, the restraint geometry, the initial slackness of the system and the stretching properties of the restraint. Incorporation of energy absorbers into the system can reduce restraint loads and alter the relationship between load and vehicle deceleration.

To investigate these factors, dynamic tests were done on a crash simulator to measure restraint loads and dummy movement with:

- (a) Conventional all webbing restraints having separate anchorages for the lap and sash straps. (Four-point system).
- (b) Conventional all webbing restraints with the sash strap joined to the lap strap. (Three-point system).
- (c) Conventional four-point systems with rigid and cushioned seats.
- (d) Conventional four-point systems fitted with initial slack, fitted tightly and fitted with the straps preloaded.
- (e) Energy absorbing systems with two alternative types of energy absorber installed in the sash strap.

The test acceleration pulses ranged from a peak acceleration of  $90 \text{ m/s}^2$  to a peak of  $280 \text{ m/s}^2$ , although not all configurations were tested over this whole range. The lowest acceleration was intended to produce loads comparable to the current design strength of aircraft restraint systems (which is based on a deceleration of  $9g$  on an occupant of mass  $77 \text{ kg}$  with a factor of safety of  $1.33$ ). The high accelerations were comparable with the design longitudinal pulse suggested in the Crash Survival Design Guide<sup>1</sup> for the cockpit region of light aircraft. (This is a triangular pulse with an average acceleration of  $15g$ , peak  $30g$  and velocity change of  $15 \text{ m/s}$ ). The high acceleration pulse was also comparable to that used in automotive test conditions, and provided for testing an energy absorber designed for automotive use.

The crash simulator sled acceleration stroke was approximately one metre. This corresponds to a vehicle stopping distance of a little less than one metre and also to the stopping distance implied by the Crash Survival Design Guide pulse. The distance was greater than that commonly used in automotive restraint tests and in earlier A.R.L. tests<sup>2,3</sup>. Comparison with these earlier tests, which used a similar peak acceleration range but lower velocity changes, allowed assessment of the relative importance of peak acceleration and velocity change.

The work was done as part of the Crash Safety Programme supported by the Department of Transport (Air Transport Group).

## 2. TEST EQUIPMENT

### 2.1 Crash Simulator

The tests were carried out on the General Motors Holden's "Hyge" crash simulator. This machine reproduced the essential dynamics of a crash deceleration by accelerating a sled carrying the test seat and restrained dummy from rest to the required velocity. The acceleration pulse was approximately sinusoidal.

### 2.2 Test Dummy

An "Alderson" VIP50 anthropomorphic dummy (mass  $77 \text{ kg}$ ) representing a 50th percentile male was used. It was clothed in cotton stockinette garments as shown on Fig. 1.

### 2.3 Test Frame and Seat

A test frame mounted on the sled provided anchorages for the seat and restraint as shown in Fig. 1. Most seat belt installations have the high mounting for the sash strap on the outer side of the seat relative to the cabin, therefore the side of the test assembly having the high sash anchorage is referred to as the "outer side", and the side with the low mounting for the sash or the intersection of the sash and lap straps at the buckle, is referred to as the "inner side".

The seat base had a strong frame and a seat pan formed by a lattice of seat belt webbing as

shown in Fig. 2. In most tests this was covered by a plastic foam cushion, but in four tests the cushion was replaced by a rigid wooden platform. Unless referred to as a rigid seat test, results apply to the cushioned seat.

#### **2.4 Instrumentation**

The loads in the straps adjacent to the anchorages, the horizontal load in the seat and the sled acceleration were measured and recorded on an oscillograph. Velocity was calculated by integrating the sled acceleration pulse. Movement of the dummy was recorded by two high speed cine cameras. One of these was mounted on the sled, the other was in a fixed position on the opposite side of the sled. Timing marks on the film and oscillograph trace allowed synchronization of the records.

### **3. THE RESTRAINT SYSTEMS**

#### **3.1 Four-point System**

The inner side of the four-point system is shown on Fig. 1. The position of the outer lap strap anchorage corresponded to the position of the inner lap anchorage, but on the other side of the seat; the upper sash strap was connected to the frame by the link AB.

In addition to tests with conventional webbing straps, tests were carried out with energy absorbers in the sash strap. Two types of energy absorber were tested; these were designated type A and type B. Type A was fitted to the link AB at A, whilst type B replaced the link AB. The length of webbing between A and the lower sash anchorage was the same for all tests.

#### **3.2 Three-point System**

This was an automotive lap sash assembly. The upper sash and outer lap anchorage positions were the same as with the four-point system, but the straps from these anchorages were joined to a common inner lap strap at the buckle as shown on Figs. 3 and 4. The outer lap and sash straps were formed from a continuous length of webbing which could slide through the buckle tongue.

The assembly was tested with the common inner lap strap anchored at two alternative positions, shown on Figs. 3 and 4.

### **4. THE ENERGY ABSORBERS**

The Type A energy absorber, shown on Fig. 5a was a commercial unit which dissipated energy by twisting a torsion bar. Extra webbing on the end of the sash strap was stored on a reel, the rotation of which was controlled by the torsion bar. When the torque from the tension in the strap exceeded the torsional strength of the bar the reel rotated and allowed the sash strap to extend. Tests with this type of load limiter have been described by Seiffert<sup>4</sup> et al.

The type B unit was developed at A.R.L. and dissipated energy by plastic bending of two mild steel strips. These were folded to a U shape and fitted in a case. One end of each strip was welded to the case. Load was applied to the case and the other end of the strips. When the load overcame the bending strength of the strips the fold rolled along the case allowing the unit to extend. Construction is shown on Fig. 5b. Loose packing pieces stabilized the strips in the case. The unit has been described previously<sup>5</sup>.

### **5. PROCEDURE**

The nominal peak acceleration levels were 90, 180, 240 and 300 m/s<sup>2</sup>. These values were not achieved exactly and actual peak values were 93, 170, 220 and 280 m/s<sup>2</sup>.

Conventional four-point systems with a cushioned seat and 25 mm of slack were tested at all acceleration levels. Conventional four-point systems were tested at 170 m/s<sup>2</sup> peak acceleration with a rigid seat, tight and preloaded straps. Conventional three-point systems were also tested at peak accelerations of 170 m/s<sup>2</sup> with a cushioned seat and 25 mm slack.

Energy absorbing systems with a cushioned seat and 25 mm slack were tested with peak accelerations of 170 and 280 m/s<sup>2</sup>. The test sequence is shown in Table I. The final test, without dummy or restraint was to determine the load produced by seat inertia.

In each test the dummy was positioned centrally in the seat and against the backrest. A new belt assembly was fitted and adjusted to the required position. Except for tests with tight or

preloaded straps the assembly was adjusted to allow 25 mm of forwards movement of the dummy. This is consistent with the amount of slack specified by the Australian Design Rules<sup>6</sup>, and Regulation for Testing Seat Belts<sup>7</sup> proposed by the Economic Commission for Europe (E.C.E.). Details of the method used for setting the slack are given in a previous A.R.L. Report<sup>3</sup>.

In the test with tight straps the straps were tightened as much as possible by hand, using the normal adjusters.

In the test with the preloaded straps, the normal adjusters were used to obtain a 'snug' fit and tension was applied to the straps by moving the anchorages backwards by a mechanical loading device. The anchorages were secured with tension in the belt.

After adjusting the straps the webbing was marked where it passed through adjusters, and the test pulse was applied. After the test the webbing was checked for slip and energy absorber extensions were noted.

## 6. RESULTS AND DISCUSSION

### 6.1 Comparison of Four-point and Three-point Systems

Both configurations were tested with 25 mm slack and sled peak accelerations of  $170 \text{ m/s}^2$ . Typical strap load traces are shown on Fig. 6. The maximum loads are summarised in Table II A, and it is seen that the total strap load was similar with either system. The upper sash load was slightly smaller and the outer lap load slightly greater with the four-point system. This was probably because the lower sash strap was higher on the dummy, as shown on Figs. 7 and 8. The load distribution on a body would appear to be better with the three-point system, but the four-point configuration would have been better if the lower sash anchorage had been lower or further forwards.

The three-point systems were tested with the inner lap strap attached at two alternative positions. These gave a noticeable difference in the slope of the lap strap in the unloaded condition, as shown on Figs 3 and 4 but during the tests the loads developed in the straps, given in Table II A, and the slopes of the straps, as shown on Figs 8 and 9 and in Table II B, were approximately the same with both anchorage positions.

As described in section 3.2 the strap forming the sash and overlap strap could slide through the buckle tongue, but examination of the cine film showed that slip only occurred late in the acceleration pulse.

### 6.2 Comparison of Tests with Cushioned and Rigid Seats

Four-point assemblies were tested at  $170 \text{ m/s}^2$  peak acceleration with the flexible seat cushion and with the rigid seat. Typical load and acceleration traces are shown on Fig. 10, and results are summarized in Table III. When set up with 25 mm slack the strap loads with either rigid or cushioned seats were approximately the same. In all tests with the cushioned seat there was an abrupt increase in the seat load at about the time the dummy reached its furthest forward position ('Peak seat load' on Fig. 10.). This was probably a direct loading between the dummy and the front member of the seat frame (through the compressed cushion), and was particularly severe in tests at higher accelerations. It is referred to later in section 6.4.

### 6.3 The Effect of Tightening the Straps

Tight or preloaded assemblies should produce an earlier build up of load and the maximum values should be lower than an assembly fitted with initial slack. Tests to investigate these effects were carried out with the rigid seat at a sled peak acceleration of  $170 \text{ m/s}^2$ .

The strap loads in the tight system were approximately 10% less than those with 25 mm of slack as shown in Table III. Preloading the straps produced a further reduction of 10% in the lap strap, but did not reduce the sash load. The preload applied was approximately 600N but this dropped to about 200N by the time the acceleration pulse was applied. The loads in the tight and preloaded systems were only developed slightly earlier than with the slack system as shown in Table III.

### 6.4 The Effect of Sled Peak Acceleration on the Strap and Seat Loads.

Strap and seat loads developed in a test on a conventional four-point system at a sled peak acceleration of  $280 \text{ m/s}^2$  are shown on Fig. 11. The sharp peak in the seat load referred to in section

6.2 is evident. Vertical loading of the seat was not measured, but elongation of bolt holes in the front legs of the seat indicated that a load in excess of 18kN had been developed. The magnitude of these seat loads would depend on the rigidity of the seat frame and dummy, or body, so the possibility of such loading should be considered in the design of the seat. There are two important reasons for such consideration, firstly such a shock loading to the spine or pelvis could be injurious, and secondly the seat and its attachments could be overloaded.

The peak loads in the sash strap are seen on Fig. 11 to have been reached later than those in the lap strap, and therefore the maximum value of the sum of the loads in the straps. (the total strap load) was less than the sum of the maximum loads in the individual straps. The maximum strap and seat loads, and the total strap loads are shown over the range of peak accelerations from 93 to 280  $m/s^2$  in Table IV. The total strap load is plotted against peak acceleration on Fig. 12, and this indicates that the typical aircraft design load of 9.1 kN (170 lb x 9g x 1.33 = 2060 lbf = 9.1 kN) would be reached with an aircraft deceleration peak of about 80  $m/s^2$  corresponding to 8g.

### 6.5 Dummy Displacement

The maximum forward displacement of the dummy torso in the test of the conventional four-point system at a peak acceleration of 280  $m/s^2$  is shown on Fig. 13. Shoulder displacement was 300 mm.

The maximum forward displacements of hip and shoulder datum points with the four-point system, over the range of peak accelerations from 93 to 280  $m/s^2$  are shown on Fig. 14, where the upper sash load is plotted against shoulder displacement, and the combined lap strap loads (inner plus outer lap) are plotted against hip displacement. The lines (AB and CD respectively) also correspond approximately to load deflection measurements made successively during a single test.

Tests with the three-point system and with the rigid seat both resulted in slightly less shoulder movement and slightly more movement at the hip. Tightening the straps produced less movement at both places.

### 6.6 The Effect of Energy Absorbers in the Sash Strap.

The development of the loads in the sash straps of the conventional and energy absorbing systems at a sled peak acceleration of 280  $m/s^2$  are shown on Fig. 15. The type B (A.R.L.) unit is seen to have limited the load to half the value developed in the conventional system, and to have maintained an almost uniform load. The load was less uniform with the type A (commercial) unit, but the peak load was still much less than with the conventional sash strap.

The reduction in load was achieved by permitting a greater extension of the restraint. Movement of the shoulder is shown on Fig. 15 and the extreme forward position of the dummy with the energy absorbing system is shown on Fig. 16 (cf. Fig. 13 for the conventional system)

The maximum upper sash strap loads, displacement of the shoulder and extension of the energy absorbers are summarized in Table V and plotted against peak acceleration on Figs 17 and 18. At the maximum peak acceleration of 280  $m/s^2$  it is seen that for the 50% reduction of load there was a 50% increase in shoulder movement. It can also be deduced from Fig 17 that the sash load in the energy absorbing (type B) system at a sled peak acceleration of 280  $m/s^2$  corresponded to the load to be expected in the conventional system at a sled peak acceleration of approximately 120  $m/s^2$ . Sash strap loads are plotted against shoulder displacement on Fig. 19 to indicate the "trade off" of load against displacement.

The two types of energy absorbers displayed approximately similar effectiveness, with type B giving marginally greater reduction in load, probably because of its more uniform load extension characteristics.

The loads in the lap straps were up to 13% greater, when the energy absorbers were fitted in the sash straps. (see Table VI). This was probably because the increased torso movement transferred load to the pelvis, however the total strap load was lower with the energy absorbing system than with the conventional assembly. In a previous report<sup>1</sup> it was shown that by using energy absorbers in both the sash and pelvic restraint, the loads in all the straps can be reduced.

### 6.7 Comparison with Previous Tests

The restraint loads depend on the peak acceleration and the velocity change. In this series of tests the acceleration distance was approximately constant and velocity change was a function of the acceleration. It is not possible to separate the relative importance of the two parameters from

these test results, but the relative importance may be inferred by comparison of the results with those of a previous test series which used a shorter acceleration distance<sup>1</sup>. Three-point restraints similar to those referred to in section 3.2 were used but, as is shown in section 6.1, the total strap load with the three and four-point systems are similar and therefore results of the two series can be compared. The total strap loads for both series are shown on Fig. 20 and it is seen that similar peak accelerations produced similar loads. This is also shown in Table VII and it is seen that the relationship of load to peak acceleration was much closer than the relationship to velocity change.

## **7. CONCLUSIONS**

1. Tests with a conventional seat belt indicated that the forces in the restraint could reach the typical design ultimate loads for light aircraft, at a cabin peak deceleration of only  $80 \text{ m/s}^2$  corresponding to 8g.
2. Energy absorbers in the restraint would allow the system to withstand cabin decelerations of greater severity without an increase in the restraint forces.
3. Incorporation of an energy absorber into the sash strap of a restraint system reduced the load in that strap to half the value developed in the conventional configuration.
4. When tested with the same acceleration pulse, the total load developed in the straps of the three-point system or the four-point system with the cushioned or rigid seat were all approximately the same.
5. High loads were developed between the dummy and seat frame in the tests using a cushioned seat.

## **8. ACKNOWLEDGEMENT**

The assistance of General Motors Holden's by allowing use of their "Hyge" crash simulator is acknowledged.

## REFERENCES

1. Crash Survival Design Guide  
USAAMRDL Technical Report 71-22.  
US. Air Mobility Research and Development Laboratory, Fort  
Eustis, Virginia. Oct. 1971
2. Sarrailhe S.R. Dynamic tests of a Yielding Seat Belt System  
ARL Report SM 340 Aeronautical Research Laboratories  
Melbourne June 1972.
3. Sarrailhe S.R. and Hearn N.D. Dynamic test of a Yielding Seat and Seat Belt System ARL  
Report 358.. March 1975.  
Aeronautical Research Laboratories, Melbourne
4. Seiffert U.W. Three point Energy Absorbing Seat Belt System  
Carbon E and  
Ristau H. Volkswagenwerk. AG  
SAE Paper 720434
5. Sarrailhe S.R. An Energy Absorber for Crash Protective Restraint Systems  
Note ARL SM 324.  
Aeronautical Research Laboratories Melbourne, April 1968.
6. Australian Design Rules for Motor Vehicle Safety Rule 4a.  
Department of Transport Australia. July 1973.
7. *Uniform Provisions Concerning the Approval of Safety Belts for  
Adult Occupants of Power Driven Vehicles E.C.E.*  
Regulation 16. United Nations

Postal Address: Chief Superintendent,  
Aeronautical Research Laboratories,  
P.O. Box 4331,  
MELBOURNE, Victoria 3001

TABLE I  
TEST SEQUENCE AND CONDITIONS

Test <sup>1</sup> No.	Peak Accn m/s <sup>2</sup>	Vel. Change m/s	Seat	System	Strap fitting
1336	93	10	cushion	conventional 4pt	slack <sup>2</sup>
1337	93	10	cushion	conventional 4pt	slack
1338	170	14	cushion	conventional 4pt	slack
1339	170	14	cushion	conventional 4pt	slack
1340	170	14	cushion	conventional 3pt <sup>3</sup>	slack
1343	170	14	cushion	conventional 3pt <sup>4</sup>	slack
1344	170	14	cushion	conventional 3pt <sup>4</sup>	slack
1345	170	14	rigid	conventional 4pt	slack
1346	170	14	rigid	conventional 4pt	slack
1347	170	14	rigid	conventional 4pt	tight
1348	170	14	rigid	conventional 4pt	preloaded
1349	170	14	cushion	EA type A 4pt	slack
1350	170	14	cushion	EA type B 4pt	slack
1351	220	16.6	cushion	conventional 4pt	slack
1352	280	19	cushion	conventional 4pt	slack
1353	280	19	cushion	EA type A 4pt	slack
1354	280	19	cushion	EA type B 4pt	slack
1355	280	19	cushion	EA type A 4pt	slack
1356	280	19	cushion	none <sup>5</sup>	none

- Notes: 1. Test numbers allocated by G.M.H.  
 2. Slack — 25 mm.  
 3. Inner lap attached to forward anchorage  
 4. Inner lap attached to rear anchorage.  
 5. No dummy. Test to determine seat inertia load.

TABLE IIA  
 MAXIMUM STRAP LOADS WITH CONVENTIONAL FOUR-POINT AND THREE-  
 POINT SYSTEMS

Sled peak acceleration 170 m/s<sup>2</sup> Slack 25 mm

Test No.	System	Max. Strap load kN					
		Upper sash	Outer lap	Lower sash	Inner lap	Common inner lap	Total
1338	4 Point	5.7	5.6	3.5	5.3		20.1
1339	4 Point	6.0	5.3	4.5	5.3		21.1
1340	3 Point	6.2	4.8			8.9	19.9
1343	3 Point	6.7	4.9			9.3	20.9
1344	3 Point	6.7	4.7			8.9	20.3

TABLE IIB  
 THREE-POINT SYSTEM INNER ANCHORAGE POSITIONS AND STRAP ANGLES

Anchorage position		Rear		Forward	
		Installed	Loaded <sup>2</sup>	Installed	Loaded <sup>3</sup>
Distance of anchorage below datum <sup>1</sup>	mm	130	130	130	130
Distance of anchorage behind datum <sup>1</sup>	mm	70	70	-20	-20
Angle of line from anchorage to location of lap belt on dummy	degrees <sup>2</sup>	45		60	
Angle of common strap	degrees <sup>2</sup>	54	40	67	42
Angle of strap over lap	degrees <sup>2</sup>		19		23
Angle of Sash at lap	degrees <sup>2</sup>		69		73

- Notes: 1. Datum is the intersection of the seat and seat back.  
 2. Angles are projected angle to the horizontal.  
 3. Approximately the minimum angle in the test.

TABLE III  
 RESTRAINT LOADS WITH CUSHIONED AND RIGID SEATS AND WITH SLACK, TIGHT AND  
 PRELOADED STRAPS.

Conventional four-point systems. Sled peak acceleration  $170 \text{ m/s}^2$

Test No.	Seat	Strap fitting	Max. Strap Load kN				Max. <sup>1</sup> Seat Load kN	<sup>2</sup> T <sub>1</sub> ms	<sup>3</sup> T <sub>2</sub> ms
			Upper sash	Lower sash	Outer lap	Inner lap			
1338	cushion	slack	5.7	3.5	5.6	5.3	6.23	43	52
1339	cushion	slack	6.0	4.5	5.3	5.3	4.9	39	52
1345	rigid	slack	6.1	4.7	5.8	5.1	3.6	39	54
1346	rigid	slack	5.7	4.5	5.8	5.1	3.6	41	52
1347	rigid	tight	5.3	4.0	5.1	4.7	4.0	39	50
1348	rigid	preload	5.6	4.0	4.5	4.0	3.6	35	42

Notes: 1. Seat load includes seat inertia of approximately 1.5 kN

2. Time for sash load to reach 2kN

3. Time for outer lap strap load to reach 2kN

TABLE IV  
 RESTRAINT LOADS WITH SLED PEAK ACCELERATION 93 TO 280 m/s<sup>2</sup>  
 Conventional four-point systems, cushioned seat, 25 mm slack.

Test No.	Peak Accn m/s <sup>2</sup>	Max. Strap loads kN					Max Seat load kN	
		Upper sash	Lower sash	Outer lap	Inner lap	Total <sup>1</sup>	Total <sup>2</sup>	Seat inertia <sup>3</sup>
1336	93	3.3	2.2	2.7	2.5	10.5	2.7	0.8
1337	93	3.1	2.2	3.0	2.9	11.0	2.7	0.8
1338	170	5.7	3.5	5.6	5.3	18.7	6.2	1.5
1339	170	6.0	4.5	5.3	5.3	21.0	4.9	1.5
1351	220	7.2	5.1	6.5	6.2	22.5	8.0	1.7
1352	280	8.9	6.0	7.3	7.6	27.6	12.0	2.2

- Notes: 1. Max. value of sum of strap loads  
 2. Including seat inertia  
 3. calculated seat inertia

TABLE V  
 EFFECT OF ENERGY ABSORBERS ON THE SASH LOAD AND SHOULDER MOVEMENT

Conventional and energy absorbing systems

Test No.	System	Peak accn. m/s <sup>2</sup>	Max. upper sash strap load kN	shoulder displacement mm	EA extension mm
1338	Conventional	170	5.7	220	0
1339	Conventional	170	6.1	220	0
1349	EA Type A	170	4.3	300	120
1350	EA Type B	170	4.1	250	107
1352	Conventional	280	8.9	300	0
1353	EA Type A	280	5.6	400	290
1355	EA Type A	280	5.6	— <sup>1</sup>	300
1354	EA Type B	280	4.5	440	370

Note: 1. Strap cut by arm joint of dummy.

TABLE VI  
 MAXIMUM STRAP LOADS WITH CONVENTIONAL AND ENERGY  
 ABSORBING FOUR-POINT SYSTEMS

Sled Peak acceleration 280 m/s<sup>2</sup>

Test No.	System	Max. Strap loads kN				Max. Total Load kN
		Upper sash	Lower sash	Outer lap	Inner lap	
1352	Conventional	8.9	6.0	7.3	7.6	27.6
1353	EA Type A	5.6	5.8	8.5	8.0	25
1355	EA Type A	5.6	5.3	8.2	8.0	26
1354	EA Type B	4.5	5.8	7.7	7.6	23

Note: 1. Max value of sum of strap loads.

TABLE VII  
 COMPARISON WITH PREVIOUS TESTS. LONG AND SHORT ACCELERATION DISTANCES  
 Conventional Three-point systems

Test No.	Acceleration Distance mm	Peak accn m/s <sup>2</sup>	Velocity change m/s	strap loads kN			
				upper sash	outer lap	inner lap	total
1344	830	170	14	6.7	4.7	8.9	20.3
619 <sup>1</sup>	420	180	11	6.2	4.7	8.9	19.8
623 <sup>1</sup>	420	240	13	7.1	7.1	11.8	26.0

Note: 1. Data from Ref. 3.

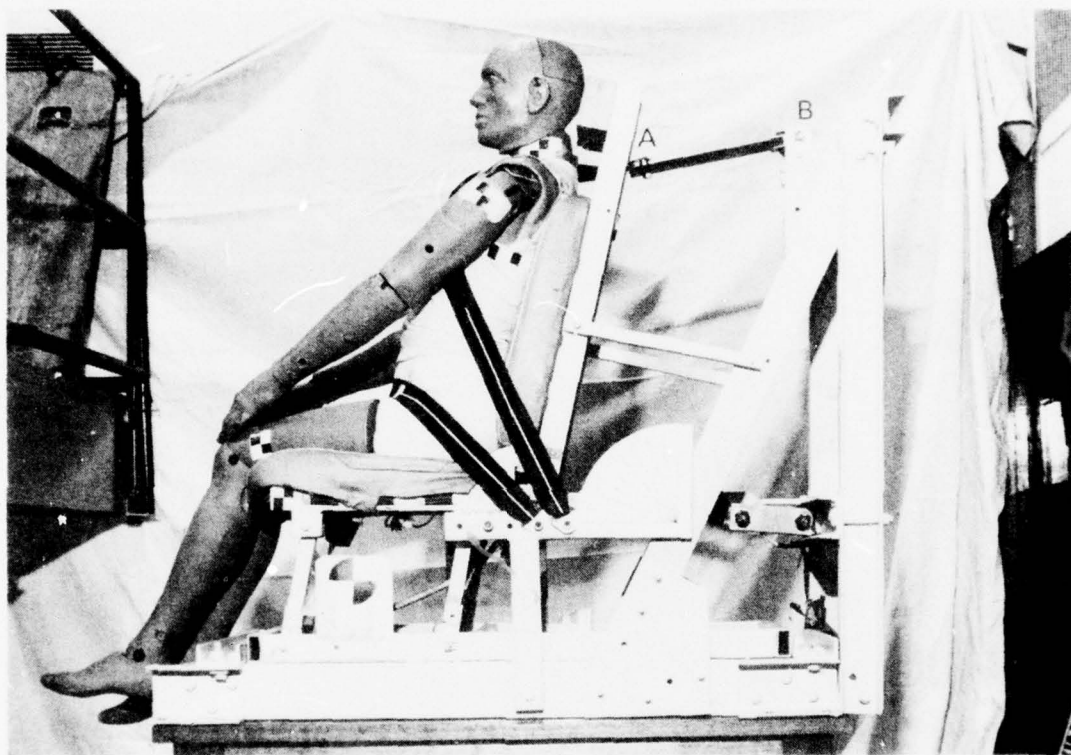

THE TEST FRAME, SEAT AND DUMMY WITH CONVENTIONAL FOUR-POINT RESTRAINT SYSTEM VIEWED FROM THE "INNER" SIDE. UPPER END OF SASH STRAP ANCHORED AT A.

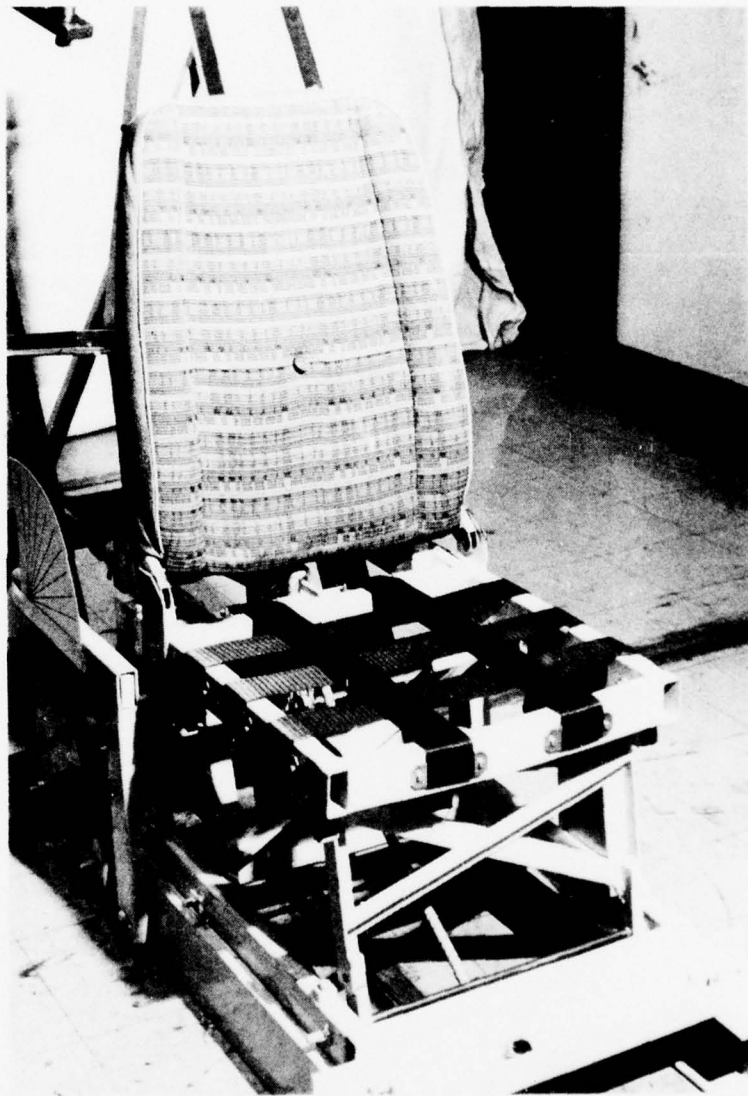

TEST SEAT SHOWING SEAT PAN MADE FROM A LATTICE  
OF SEAT BELT WEBBING.

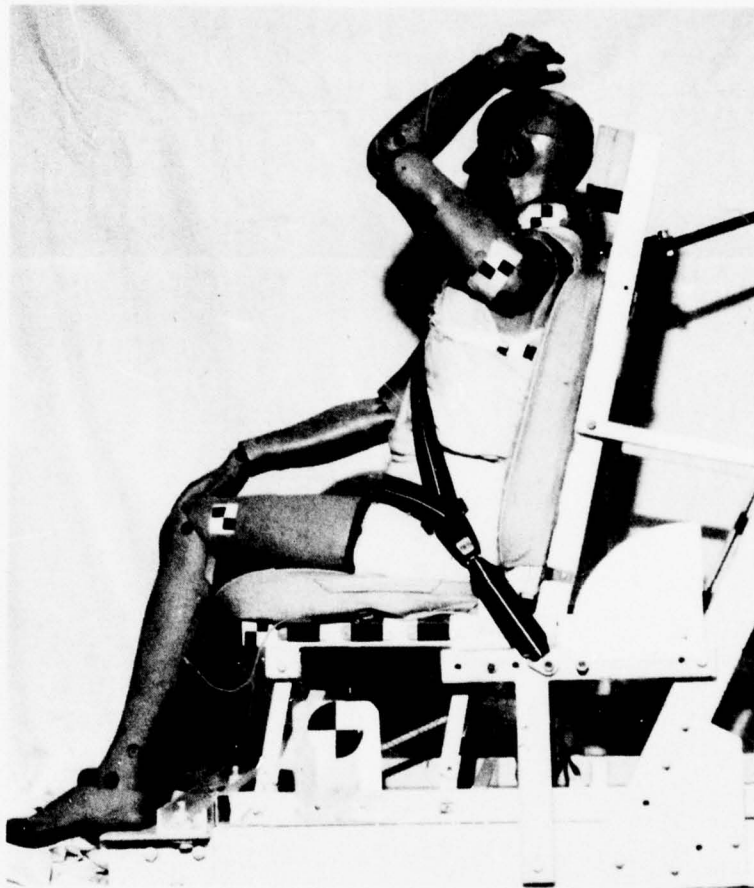

CONVENTIONAL THREE-POINT RESTRAINT SYSTEM WITH COMMON INNER LAP STRAP ATTACHED TO THE REAR ANCHORAGE POSITION.

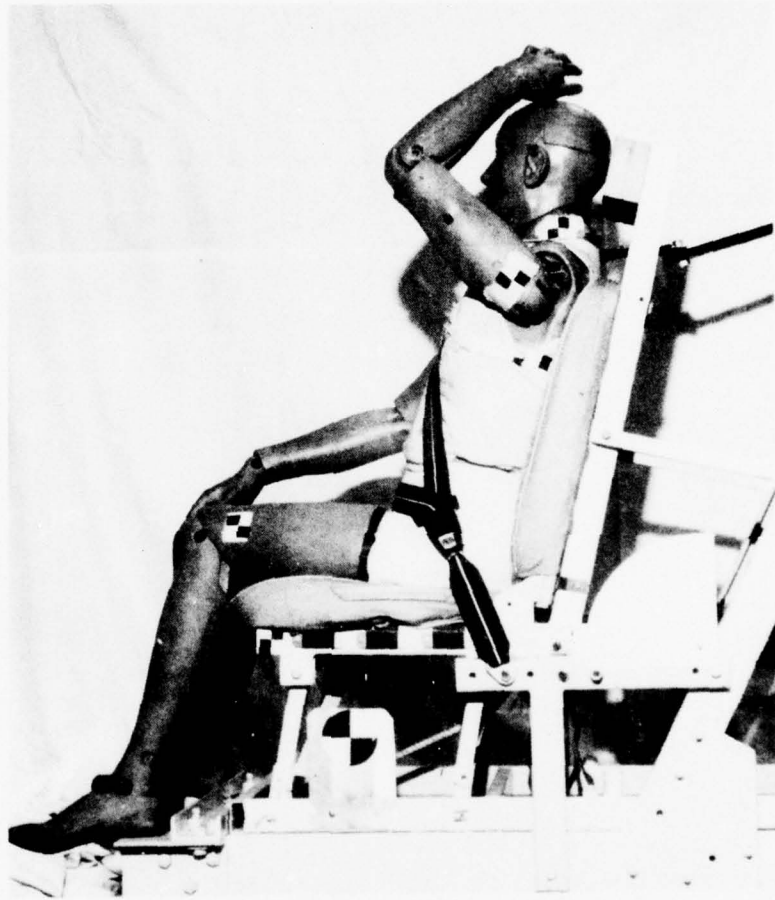

CONVENTIONAL THREE-POINT RESTRAINT SYSTEM WITH COMMON  
INNER LAP STRAP ATTACHED TO THE FORWARD ANCHORAGE POSITION.

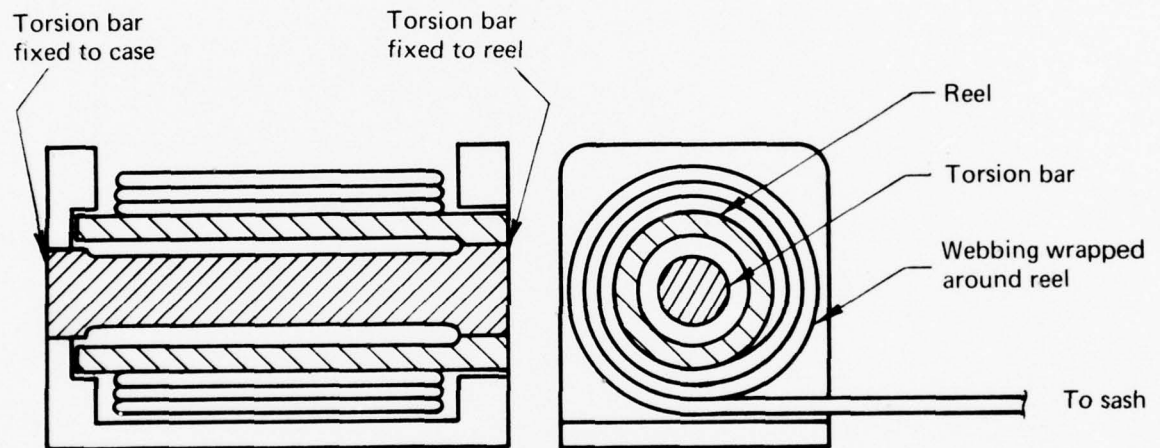

CONSTRUCTION OF TYPE 'A' ENERGY ABSORBER.  
(Commercial unit)

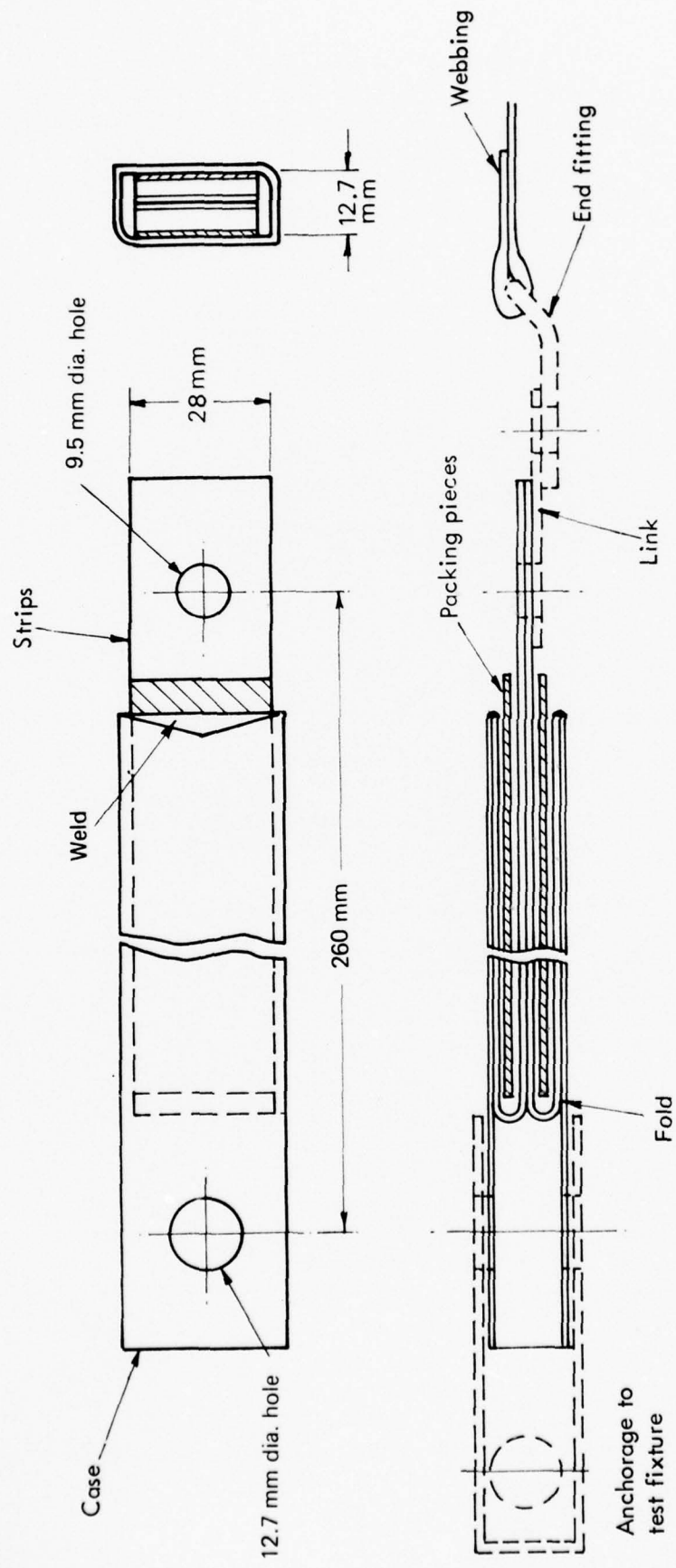

Material: Mild steel 18 B.G.

CONSTRUCTION OF TYPE 'B' ENERGY ABSORBER.  
A.R.L. unit.



STRAP LOADS versus TIME.  
Conventional three and four-point systems. Peak acc'n. 170 m/s<sup>2</sup>.

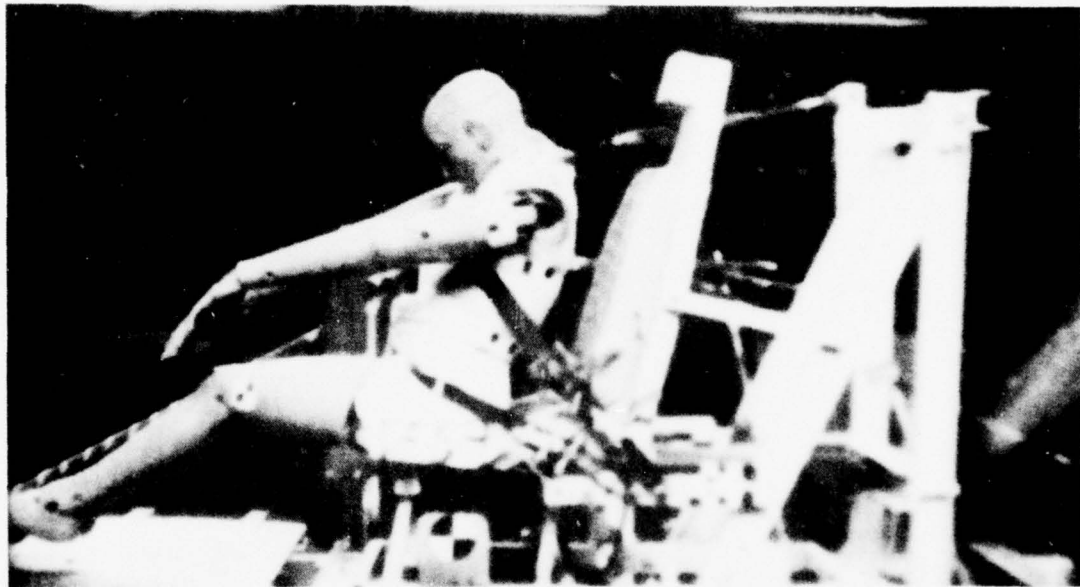

EXTREME FORWARD POSITION OF DUMMY.  
Conventional four-point system. Peak acc'n.  $170 \text{ m/s}^2$ .

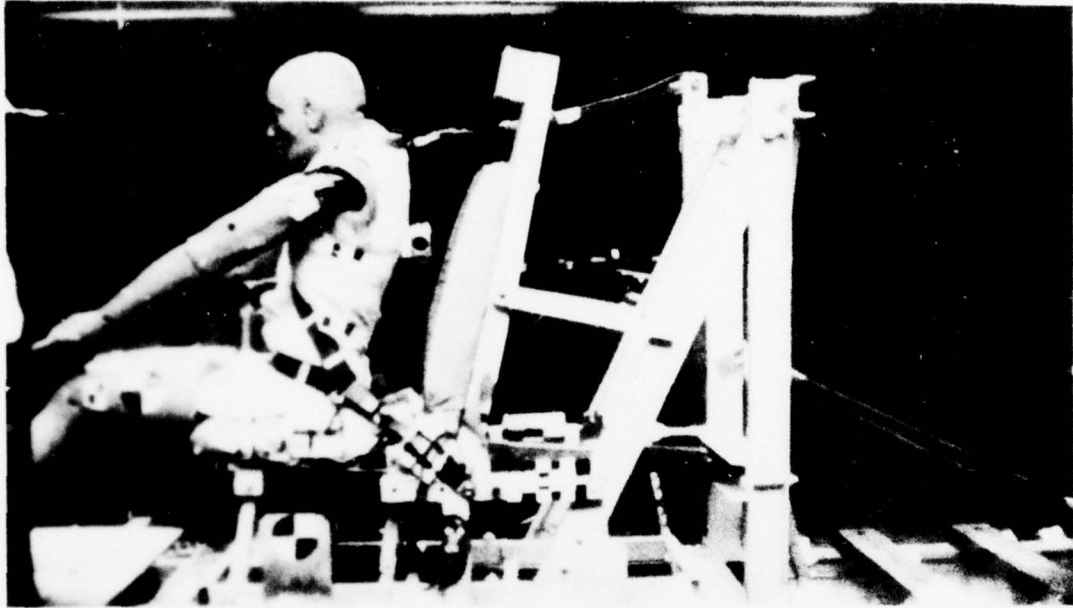

FIG. 8 EXTREME FORWARD POSITION OF DUMMY.  
Conventional three-point system. Lap strap on rear anchorage. Peak acc'n.  $170 \text{ m/s}^2$ .

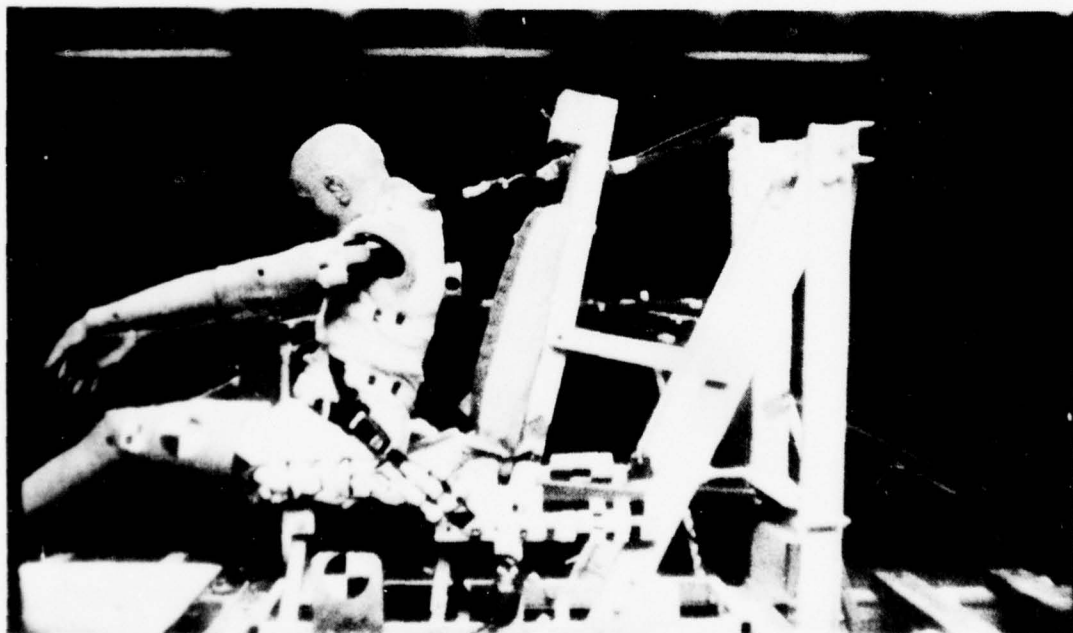
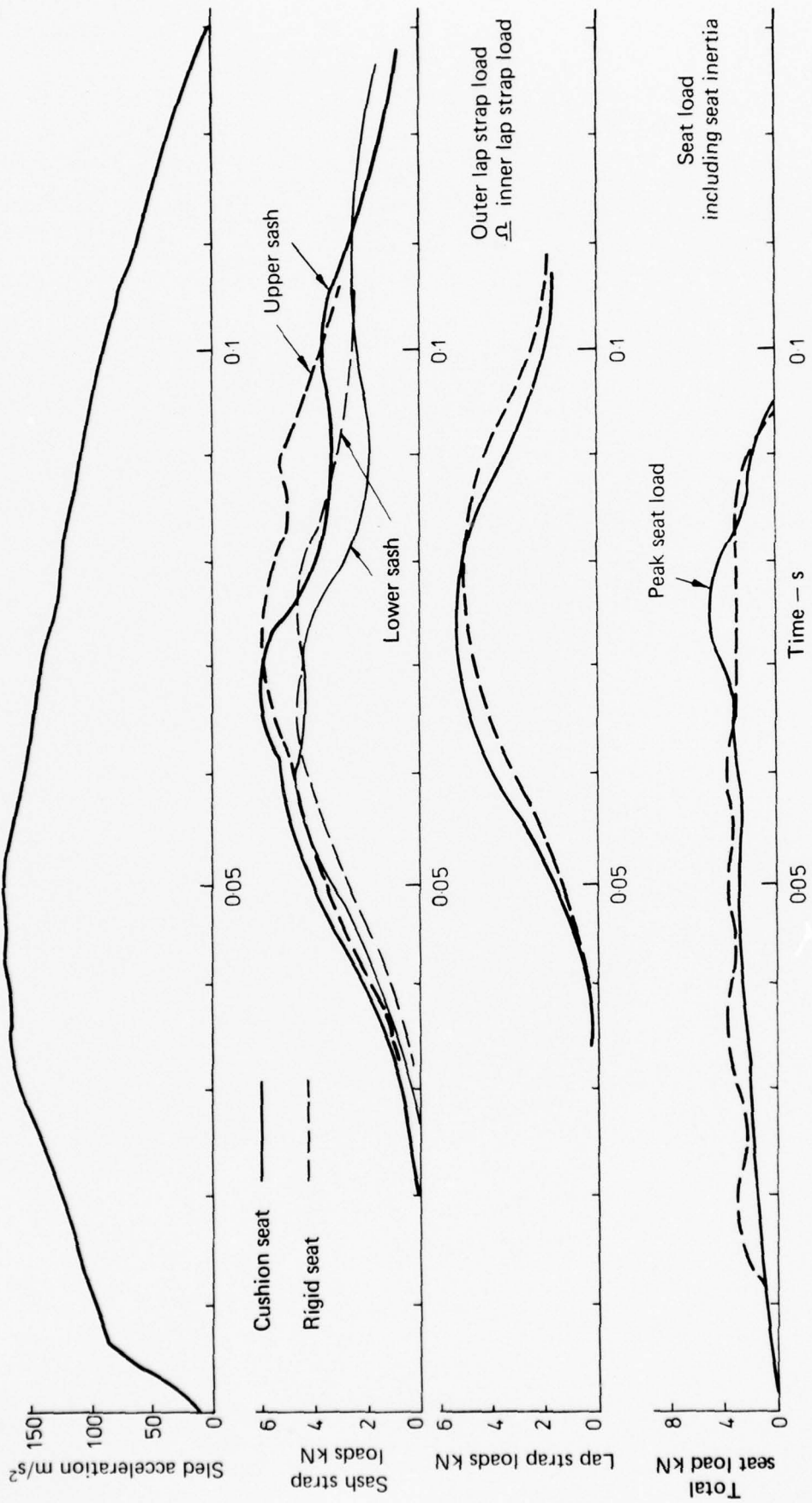
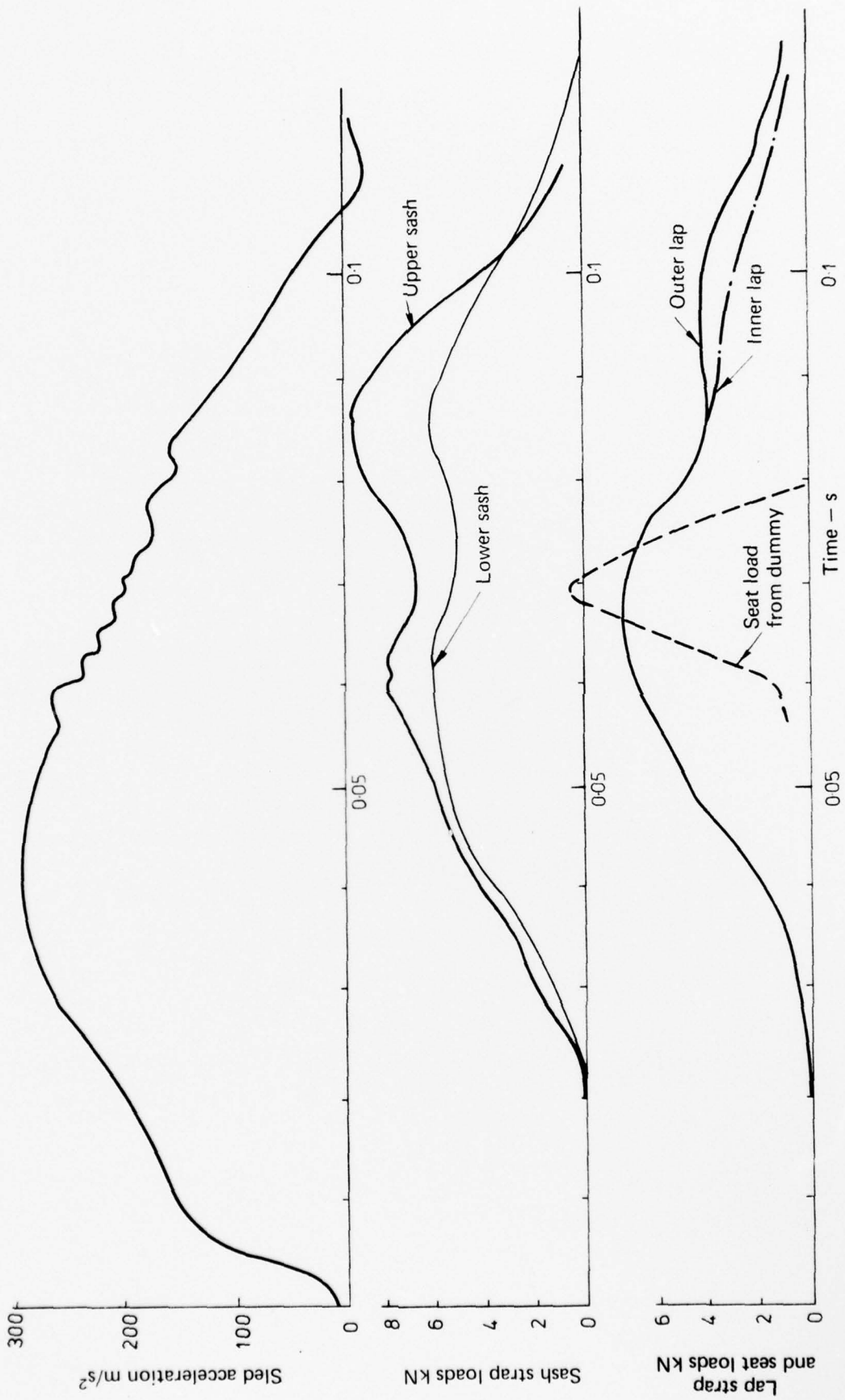

FIG. 9 EXTREME FORWARD POSITION OF DUMMY.  
Conventional three-point system. Lap strap on forward anchorage. Peak acc'n.  $170 \text{ m/s}^2$ .



SLED ACCELERATION, STRAP AND TOTAL SEAT LOADS versus TIME.  
Conventional four-point system. Rigid and cushioned seats. Peak acc'n. 170 m/s<sup>2</sup>.



SLED ACCELERATION, STRAP AND SEAT LOADS versus TIME.  
Conventional four-point system. Peak acc'n. 280 m/s<sup>2</sup>.  
(Seat load shown is from dummy only).

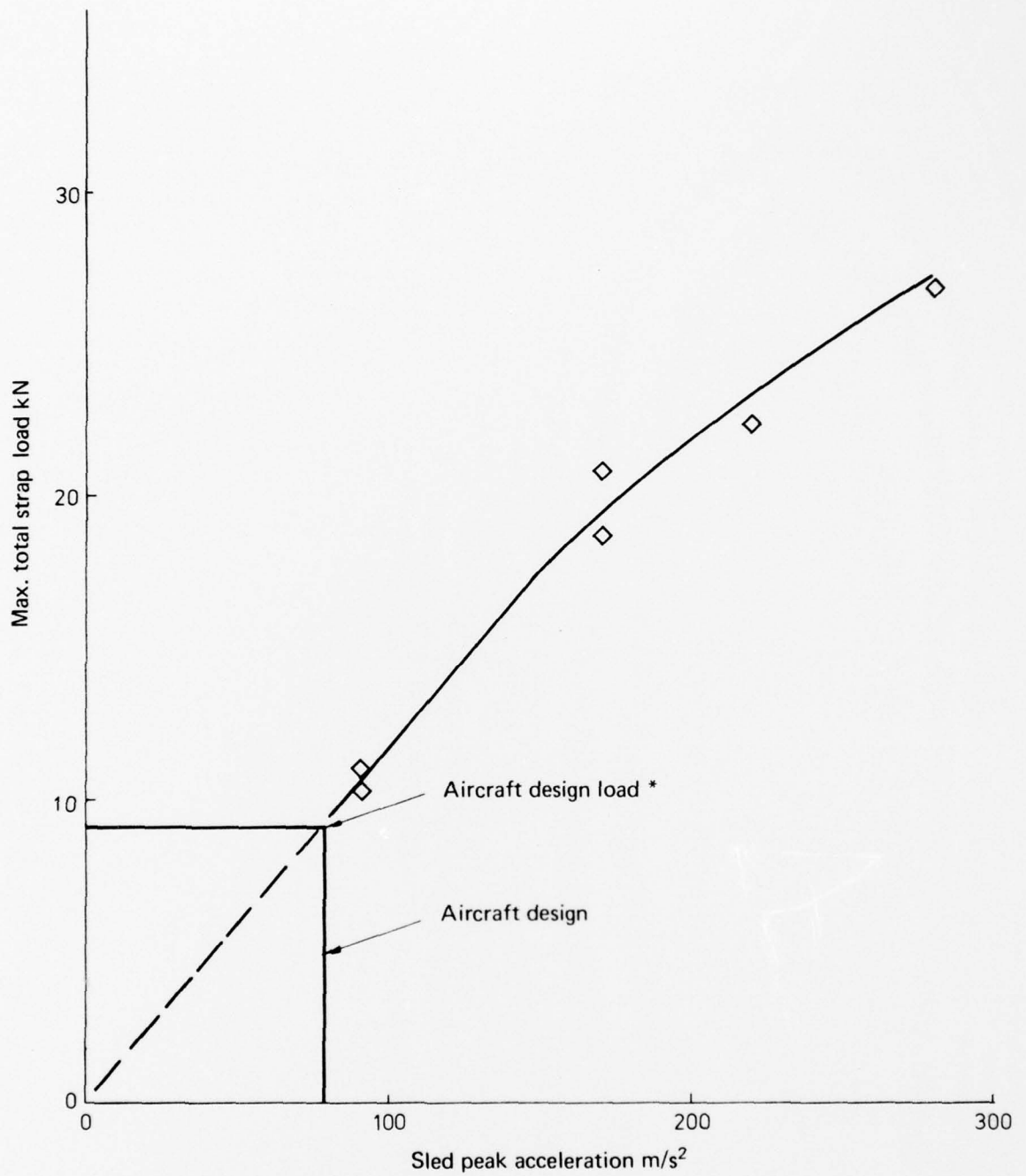

MAXIMUM TOTAL STRAP LOAD versus SLED PEAK ACCELERATION.  
Conventional four-point system. \* [9 g on 77 kg x 1.33]

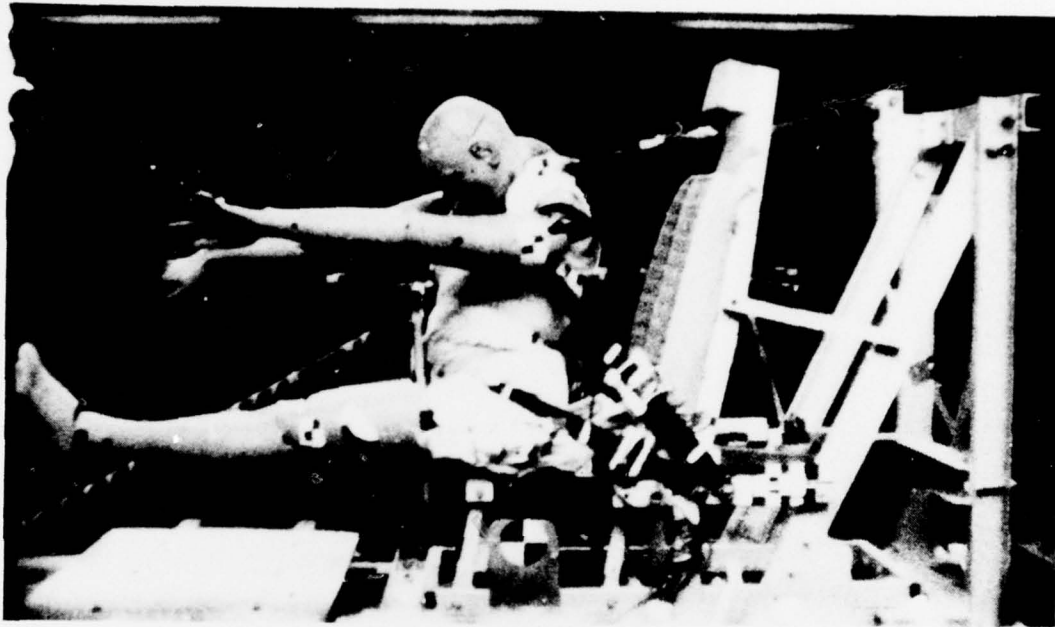

EXTREME FORWARD POSITION OF DUMMY.  
Conventional four-point system. Peak acc'n.  $280 \text{ m/s}^2$ .

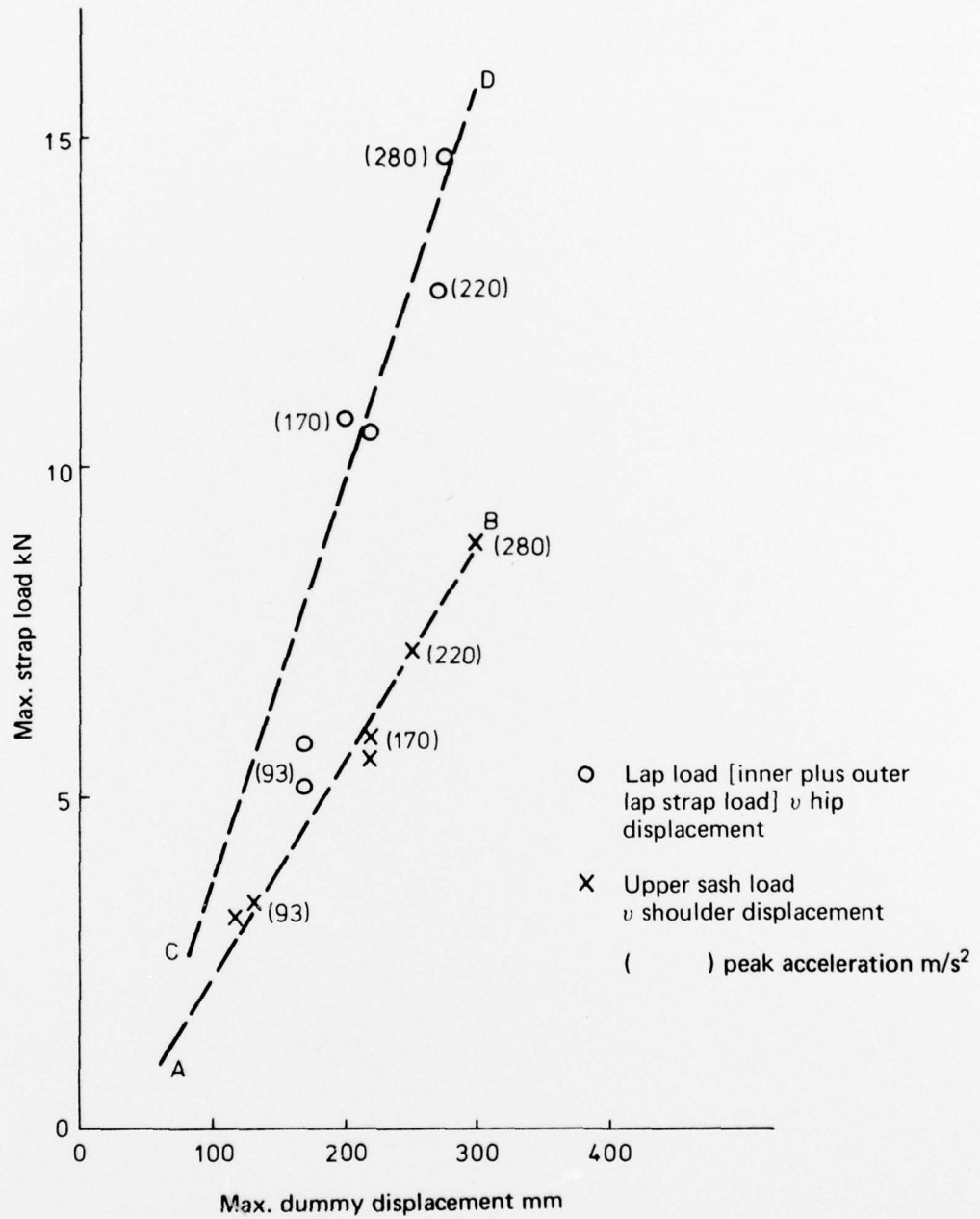

**MAXIMUM STRAP LOAD versus MAXIMUM DUMMY DISPLACEMENT**  
 Conventional four-point system, cushion seat, 25 mm slack.



UPPER SASH STRAP LOAD AND SHOULDER DISPLACEMENT versus TIME.  
Conventional and energy absorbing four-point systems. Peak acc'n. 280 m/s<sup>2</sup>.

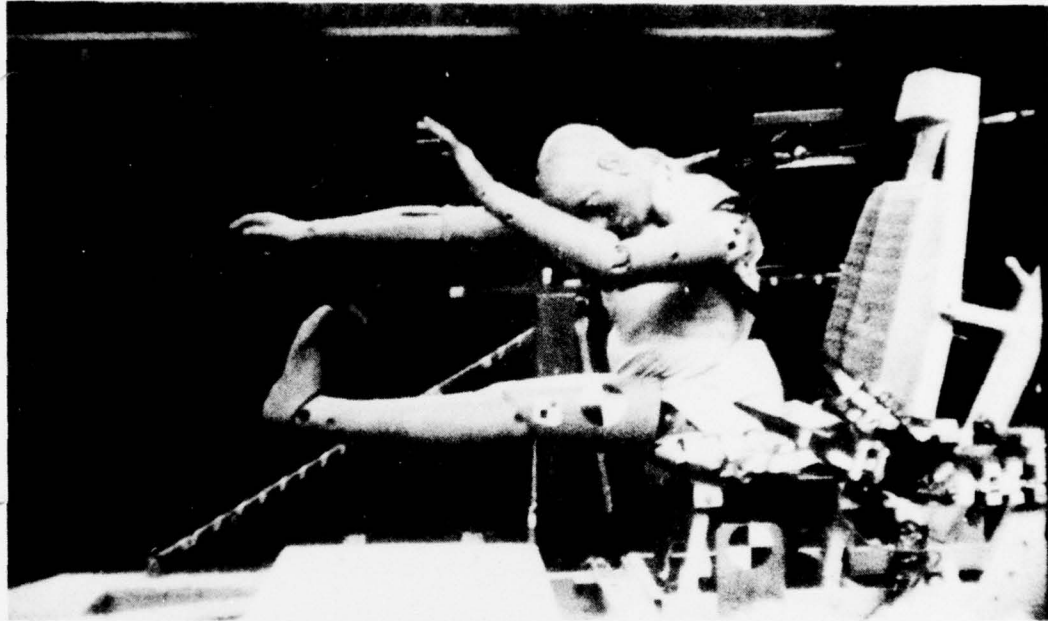

EXTREME FORWARD POSITION OF DUMMY WITH ENERGY ABSORBING SYSTEM.  
Four-point system. Peak acc'n.  $280 \text{ m/s}^2$ .

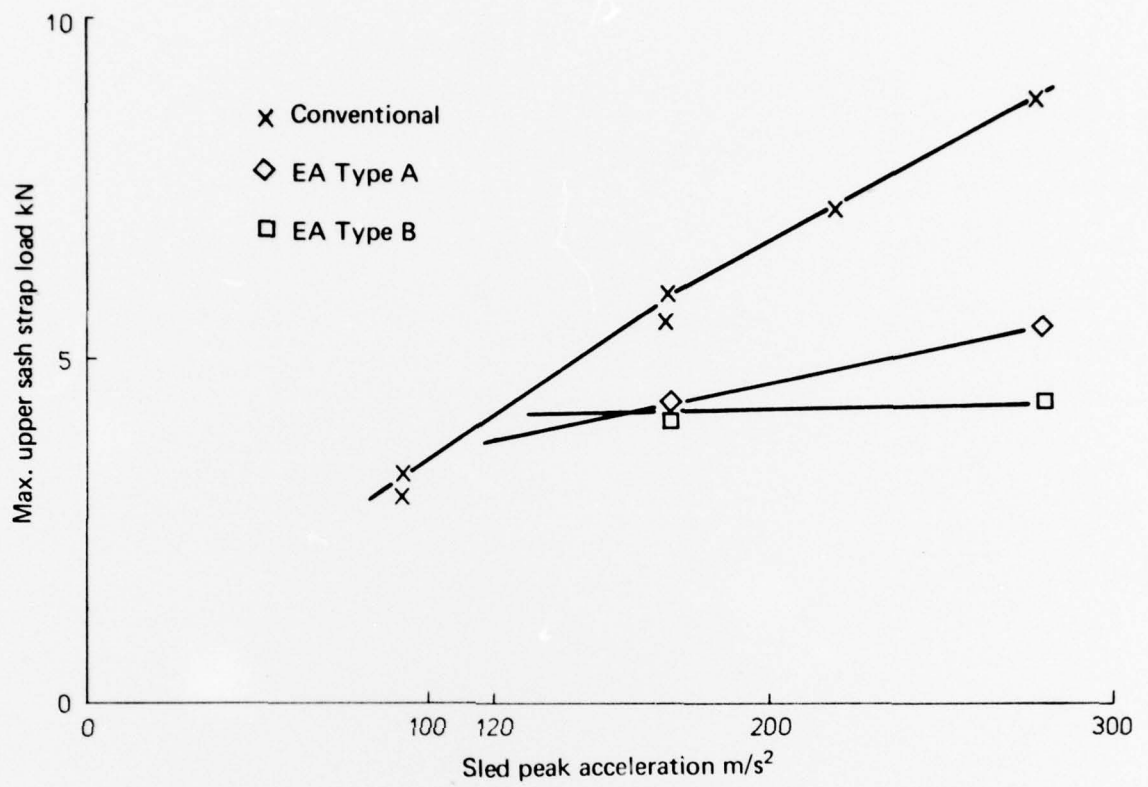

**MAXIMUM UPPER SASH STRAP LOAD versus SLED PEAK ACCELERATION**  
Conventional and energy absorbing four-point systems.

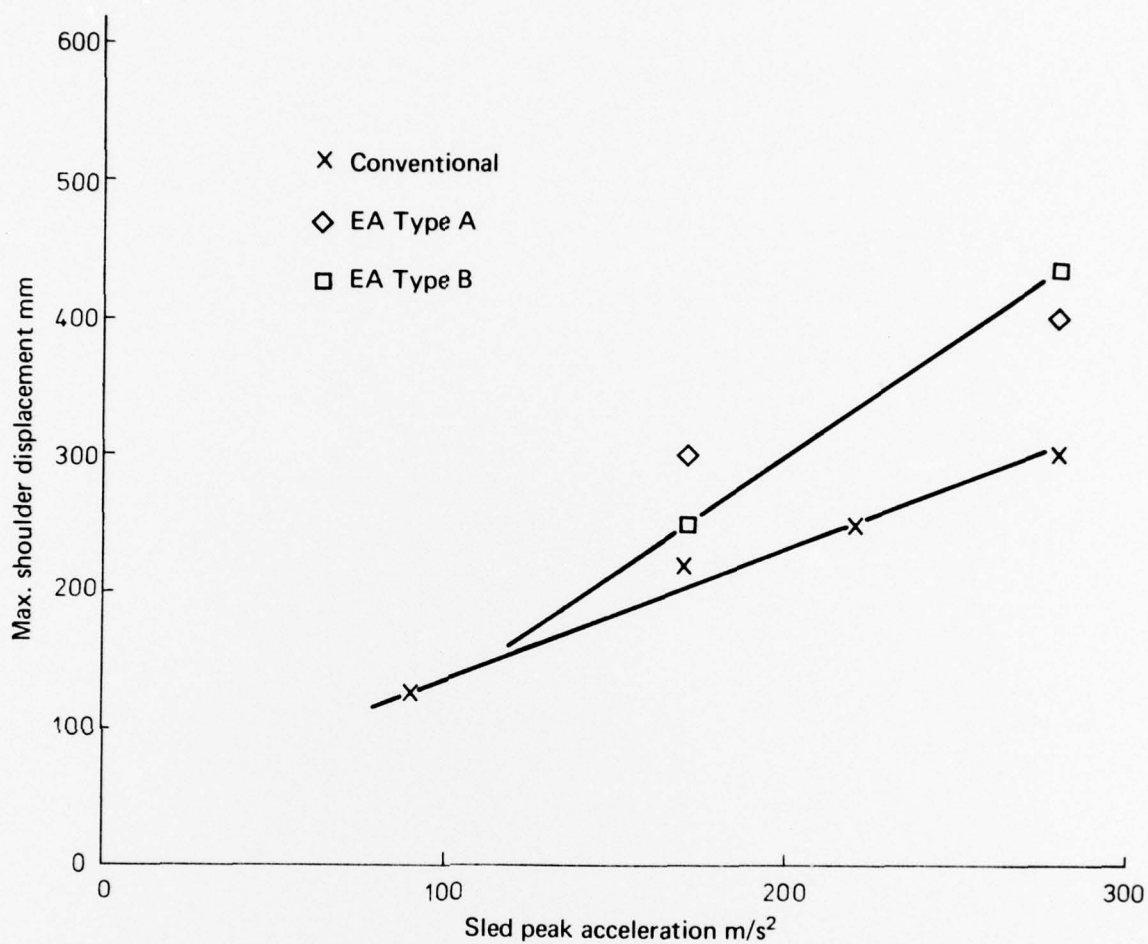

MAXIMUM SHOULDER DISPLACEMENT versus SLED PEAK ACCELERATION.  
Conventional and energy absorbing four-point systems.

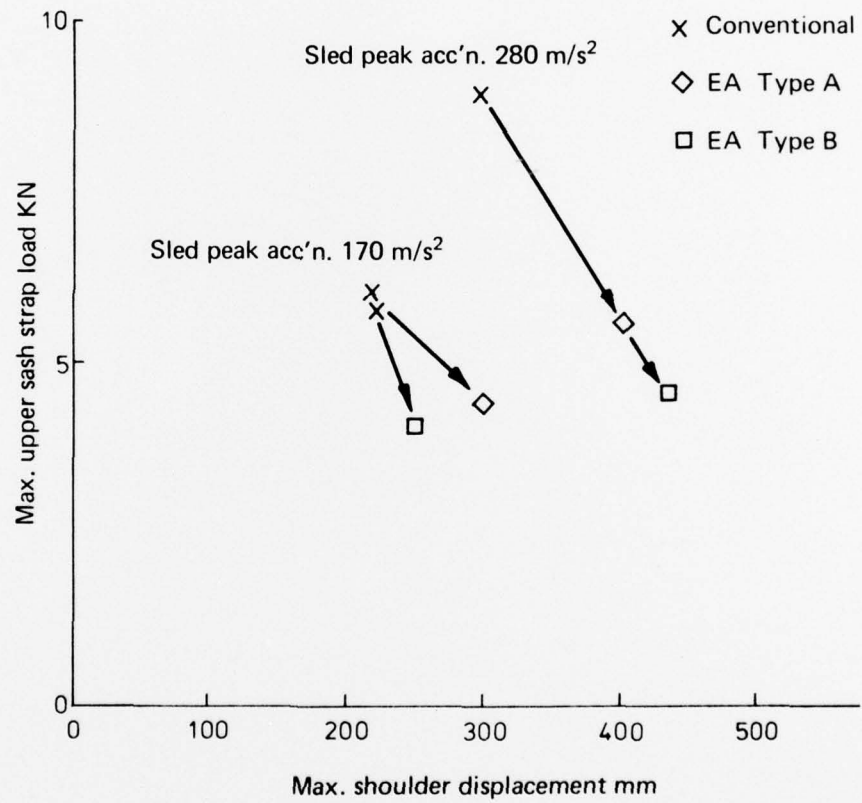

MAXIMUM UPPER SASH STRAP LOAD versus MAXIMUM SHOULDER DISPLACEMENT  
Conventional and energy absorbing four-point systems.

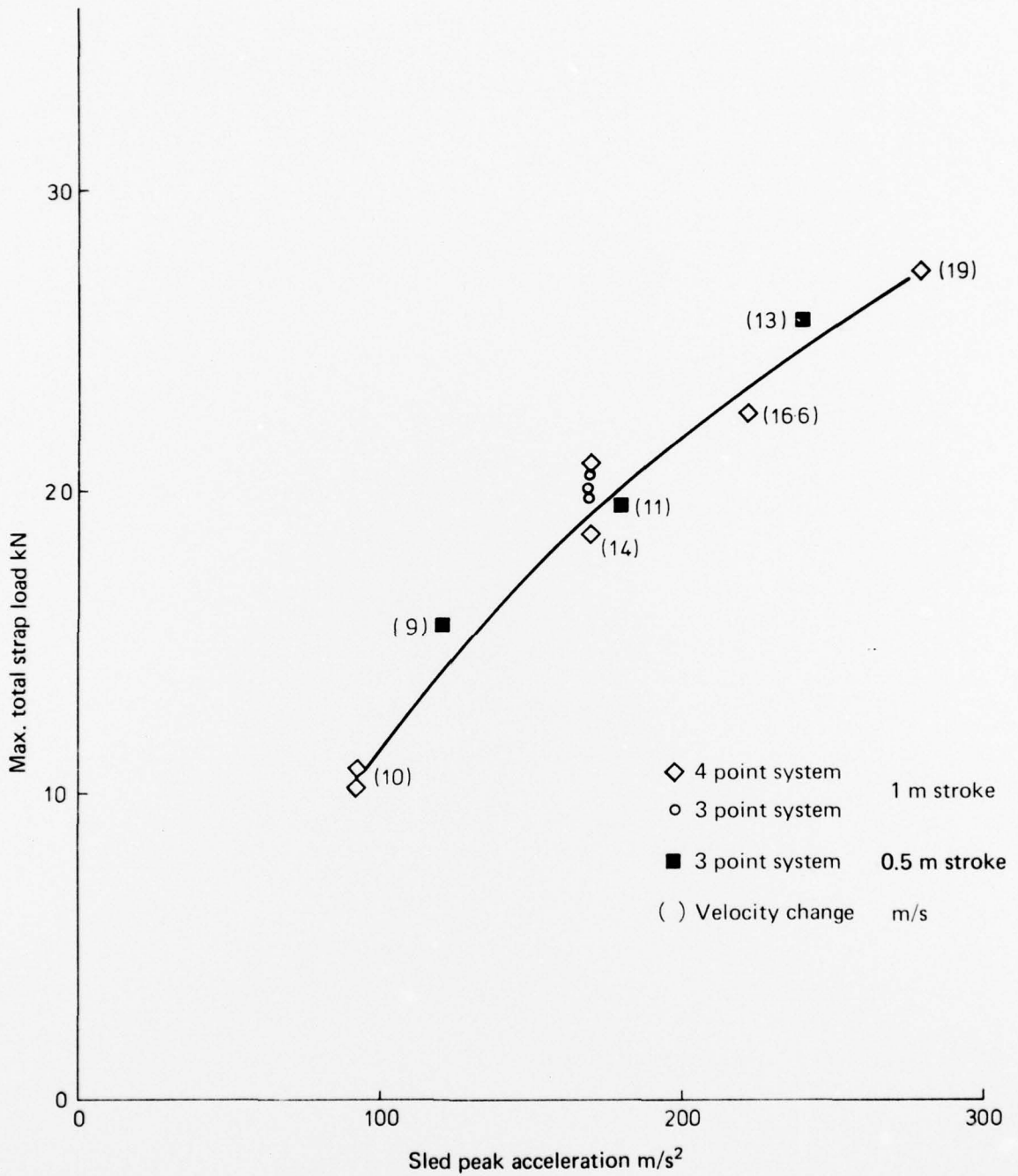

MAXIMUM TOTAL STRAP LOAD versus SLED PEAK ACCELERATION FOR BOTH LONG AND SHORT ACCELERATION DISTANCES.

## DISTRIBUTION

Copy No.

### AUSTRALIA

#### DEPARTMENT OF DEFENCE

##### Central Office

Chief Defence Scientist	1
Executive Controller, ADSS	2
Superintendent --Defence Science Administration	3
Superintendent --Assistant to Executive Controller ADSS	4
Controller --Service Laboratories and Trials Division	5
Controller --Military Studies and Operational Analysis Division	6
Controller --Programme Planning and Policy Division	7
Central Library	8

##### Aeronautical Research Laboratories

Chief Superintendent	9
Superintendent --Structures Division	10
Structures Divisional File	11
S.R. Sarraillhe )	12-13
N.D. Hearn ) co-authors	14
Library	15

##### Central Studies Establishment

Library	16
---------	----

##### Materials Research Laboratories

Library (Victoria)	17
--------------------	----

##### Air Office

Air Force Scientific Adviser	18
Library, Engineering (AMTS) Canberra	19-22
Library, A.R.D.U. Laverton	23
S.T.S.O. Support Command, H.Q.	24

##### Army Office

Army Scientific Adviser	25
The Head, Engineering Development Establishment	26
Library, Engineering Development Establishment	27
U.S. Army Standardisation Group	28

##### Navy Office

Naval Scientific Adviser	29
Superintendent, R.A.N.R.L.	30

#### DEPARTMENT OF INDUSTRY AND COMMERCE

##### Government Aircraft Factories

Library	31-32
---------	-------

#### DEPARTMENT OF TRANSPORT

##### Air Transport Group

Director-General/Library	33
Mr. P.S. Langford	34
Dr. J.C. Lane, Director of Aviation Medicine	35-36

##### Surface Transport Group

Assistant Secretary, Road Safety Research, Canberra	37
Chairman, A.C.S.V.D. Canberra	38
Chairman, A.C.S.V.D., Seat Belts Sub-Committee, Canberra	39

## DEPARTMENT OF NATIONAL RESOURCES

Secretary, Canberra 40

## STATUTORY AUTHORITIES AND PRIVATE INDUSTRY

Director: Australian Road Research Board, Vermont, Vic. 41  
Director: Standards Association of Australia, N.S.W. 42  
Dr. M. Henderson, Traffic Accident Research Unit, N.S.W. 43  
Mr. D.C. Herbert, Traffic Accident Research Unit, N.S.W. 44  
Road Safety and Traffic Authority, Victoria 45  
State Electricity Commission of Victoria, Library, H.O. 46  
C.S.I.R.O. Library, Mechanical Engineering Dept. H.O. 47  
B.P. Australia Ltd, (Mr. Gattengo) Vic. 48  
Broken Hill Pty Ltd, Central Research Labs., N.S.W. 49  
Broken Hill Pty Ltd, Melbourne Research Labs., Clayton. 50  
Commonwealth Aircraft Corporation, (Manager) 51  
Hawker de Havilland Pty Ltd, (Tech. Librarian) Bankstown 52-53  
I.C.I.A.N.Z. Library 54  
Library, Ansett Airlines of Australia 55  
Library, Qantas 56  
Library, Trans-Australia Airlines 57  
Library of New South Wales, Acquisition Department 58  
Chief Engineer: General Motors Holden's, Port Melbourne 59  
Chief Engineer: Ford Motor Company, Geelong 60  
Chief Engineer: Cooldrive Consolidated Industries, Pty. Ltd. Broadmeadows 61  
Chief Engineer: British Leyland Motor Corporation, N.S.W. 62  
Chief Engineer: Britax Wibroc, N.S.W. 63  
Chief Engineer: Rex Aviation, N.S.W. 64  
Chief Engineer: Chrysler of Australia Pty Ltd, S.A. 65  
Chief Engineer: Rainsford Metal Products Pty Ltd, S.A. 66  
T.R.W. Marrickville N.S.W. 67

### Universities

Adelaide Barr Smith Library 68  
Australian National Library 69  
Melbourne Library, Engineering School 70  
Dr. E. Hoffman 71  
Monash Professor R.W. Cumming 72  
Newcastle Library 73  
New England Library 74  
New South Wales Library, Serials Department 75  
Queensland Library 76  
Sydney Professor D.W. George, Mech. Eng. 77  
Tasmania Library 78

### Royal Melbourne Institute of Technology

Library 79  
Aero. Eng. Dept. (Mr. H. Millicer) 80  
Head of Mech. Eng. Dept. (Mr. S. Sears) 81

## CANADA

National Research Council of Canada 82-83  
C.A.A.R.C. Co-ordinator Structures -- Dr. G.R. Cowper 84  
McGill University Library 85

## FRANCE

A.G.A.R.D. Library 86

<b>GERMANY</b>		
DFVLR. West Germany		87
<b>INDIA</b>		
Department of Civil Aviation, (Director)		88
C.A.A.R.C. Co-ordinator Structures -- Professor P.N. Murthy		89-93
<b>ITALY</b>		
Fiat Co., Dr. Guieseppe Gabrielli, Torino		94
<b>NETHERLANDS</b>		
N.L.R. Amsterdam		95
Central Technical Institute, T.N.O. Apeldoorn		96
<b>NEW ZEALAND</b>		
Air Department, R.N.Z.A.F., Aero. Documents Section		97
Department of Transport, Library		98
University of Canterbury, Library		99
<b>SWEDEN</b>		
Aeronautical Research Institute		100
Chalmers University of Technology, (Professor B. Aldman)		101
Library, S.A.A.B. Linkoping		102
<b>UNITED KINGDOM</b>		
Department of Industry and Commerce, Senior Representative		103
Defence Research Information Centre		104-105
Mr. A.R.G. Brown, ADR/MAT(MEA)		106-107
Royal Aircraft Est., Library, Farnborough		108-109
Royal Aircraft Est., Mr. R.G. Thorne		110
Aircraft and Armament Experimental Est.,		111
Military Engineering Experimental Est.,		112
Military Vehicles and Experimental Est.		113
National Engineering Labs., (Superintendent) Scotland		114
The British Library, Science Reference Library, (High Holborn Divn.)		115
Aircraft Research Association, Library, Bedford		116
Fulmer Research Institute Ltd, (Research Director)		117
Motor Industries Research Association, (Director)		118
Science Museum Library		119
Road Research Laboratory, (Director) Crowthorn, Berks.		120
R.A.F. Institute of Aviation Medicine, Farnborough		121
<b>Aircraft Companies</b>		
Hawker Siddeley Aviation Ltd, Brough		122
British Aircraft Corporation Ltd, Commercial A/C Divn. Filton		123
Westland Helicopters Ltd., Yeovil		124
<b>Universities</b>		
Bristol	Library Eng. Dept.	125
Cambridge	Library Eng. Dept.	126
London	Professor A.D. Young, Queen's College	127
Manchester	Professor Applied Maths	128
Nottingham	Library	129
Southampton	Library	130
<b>Colleges &amp; Institutes</b>		
Cranfield Inst. of Tech.	Library	131

## UNITED STATES OF AMERICA

Australian Defence Research & Development Attache	132
Civil Air Attache, Washington, D.C.	133
Aerospace Research Labs., Wright-Patterson A.F.B., Ohio	134
National Technical Information Service, Springfield	135
Library, National Bureau of Standards, Washington D.C.	136
F.A.A. Aeronautical Center, Flight Standards Technical Division Okla	137
F.A.A. National Aviation Experimental Centre, Atlantic City, N.J.	138
F.A.A. Civil Aeromedical Institute -- Oklahoma	139
Dynamic Science Ultrasystems Inc., Phoenix, Arizona	140
Calspan Corporation, Buffalo, N.Y.	141
N.A.S.A. Langley Research Center, Hampton, Va.	142
National Transportation Safety Board, U.S. Dept. of Transportation	143
Chief Engineer -- Piper Aircraft Corporation, Lock Haven, Penn.	144
Chief Engineer -- Beech Aircraft Corporation, Wichita, Kansas	145
Chief Engineer -- Cessna Aircraft Company, Wichita, Kansas	146
Cessna Aircraft Coy, (Mr. D.W. Mallonee, Executive Eng.)	147
U.S. Army Research & Development Labs., Fort. Belvoir	148

### Universities

California (L.A.)	Institute of Transportation & Traffic Engineering	149
Cornell (Ithaca)	Library	150
Massachusetts	Library	151
Michigan	Dr. R.G. Snyder, Highway Safety Research Institute	152
Oklahoma	Dr. Bergoy	153
Wayne State	Professor L.M. Patrick	154

### Institutes of Technology

California	Library, Guggenheim Aero. Labs.	155
------------	---------------------------------	-----

Spares

156-167

**DOCUMENT CONTROL DATA**

<p>1. Security Grading/ Release Limitation</p> <p>(a) Document Content : Unclassified</p> <p>(b) This Page : Unclassified</p>	<p>2. Document Type/ Number</p> <p>Structures Report 359 ✓</p>
	<p>3. Document Date</p> <p>September 1975</p>
<p>4. Title and Sub-Title</p> <p><b>THE PERFORMANCE OF CONVENTIONAL AND ENERGY ABSORBING RESTRAINTS IN SIMULATED CRASH TESTS</b></p>	
<p>5. Personal Author: S.R. Sarraillhe and N.D. Hearn</p> <p>6. Corporate Author(s): Aeronautical Research Laboratories ✓</p>	
<p>7. Abstract</p> <p><i>Dynamic tests were conducted using conventional lap sash seat belt restraints, and assemblies incorporating energy absorbers in the sash strap. Three restraint geometries, rigid and cushioned seats, and assemblies with the straps slack, tight and preloaded were tested.</i></p> <p><i>The load in the sash strap with an energy absorber was half of that in the same strap of a conventional restraint in tests with the same peak acceleration of 280 m/s<sup>2</sup>.</i></p> <p><i>The results were also compared with results of previous tests where a shorter acceleration distance was used.</i></p>	
<p>8. Computer Program(s) -- Title and Language</p> <p align="center">Not applicable</p>	
<p>9. Descriptors</p> <p>Crash tests Restraints Motor vehicle accidents Seat belts Seats Aviation safety Safety engineering</p>	<p>11. Cosati Classifications</p> <p>0102, 1407, 1312</p>
	<p>12. Task Reference (RD/ P)</p> <p>(RD/ P) RD 72</p>
<p>10. Library Distribution (Defence Group)</p> <p>Central Library (Canberra) A.R.E., C.S.E., M.R.L. Air Office: Engineering, A.R.D.U. Army Office: E.D.E.</p>	<p>13. Sponsoring Agency Reference</p> <p>DCA 63/3</p>
	<p>14. Cost Code</p> <p>26-1311</p>
<p>15. Imprint</p> <p align="center">MELBOURNE -- AERONAUTICAL RESEARCH LABORATORIES 1976</p>	