

AD-A047 656

ARMY AVIATION ENGINEERING FLIGHT ACTIVITY EDWARDS AF--ETC F/O 17/4
AIRWORTHINESS QUALIFICATION EVALUATION U-21A AIRPLANE WITH LOW --ETC(U)
JAN 76 W A NORTON, R B SMITH

UNCLASSIFIED

USAAEFA-75-10

NL

1 OF 2
AD
AO47656



AD A 0 4 7 6 5 6

USAAEFA PROJECT NO. 75-10



6

AIRWORTHINESS QUALIFICATION EVALUATION U-21A AIRPLANE WITH LOW REFLECTIVE PAINT AND HOT METAL SUPPRESSORS

FINAL REPORT

RAYMOND B. SMITH
PROJECT ENGINEER

WILLIAM A. NORTON
CPT, INF
US ARMY
PROJECT OFFICER/PILOT

JANUARY 1976

DDC
RECEIVED
DEC 14 1977
F

AD No. _____
DDC FILE COPY

Approved for public release; distribution unlimited.

UNITED STATES ARMY AVIATION ENGINEERING FLIGHT ACTIVITY
EDWARDS AIR FORCE BASE, CALIFORNIA 93523

DISCLAIMER NOTICE

The findings of this report are not to be construed as an official Department of the Army position unless so designated by other authorized documents.

DISPOSITION INSTRUCTIONS

Destroy this report when it is no longer needed. Do not return it to the originator.

TRADE NAMES

The use of trade names in this report does not constitute an official endorsement or approval of the use of the commercial hardware and software.

UNCLASSIFIED

SECURITY CLASSIFICATION OF THIS PAGE (When Data Entered)

| REPORT DOCUMENTATION PAGE | | READ INSTRUCTIONS BEFORE COMPLETING FORM |
|---|-----------------------|---|
| 1. REPORT NUMBER USAAEFA PROJECT NO. 75-10 ✓ | 2. GOVT ACCESSION NO. | 3. RECIPIENT'S CATALOG NUMBER |
| 4. TITLE (and Subtitle) 6 AIRWORTHINESS QUALIFICATION EVALUATION U-21A AIRPLANE WITH LOW REFLECTIVE PAINT AND HOT METAL SUPPRESSORS, | | 9. TYPE OF REPORT & PERIOD COVERED FINAL REPORT. 25 June - 17 Sep 1975, 10. PERFORMING ORG. REPORT NUMBER USAAEFA PROJECT NO. 75-10 |
| 7. AUTHOR(s) 10 WILLIAM A. NORTON RAYMOND B. SMITH | | 8. CONTRACT OR GRANT NUMBER(s) |
| 9. PERFORMING ORGANIZATION NAME AND ADDRESS US ARMY AVIATION ENGINEERING FLIGHT ACTIVITY EDWARDS AIR FORCE BASE, CALIFORNIA 93523 ✓ | | 10. PROGRAM ELEMENT, PROJECT, TASK AREA & WORK UNIT NUMBERS 20-5-R0121-02-20-EJ |
| 11. CONTROLLING OFFICE NAME AND ADDRESS US ARMY AVIATION ENGINEERING FLIGHT ACTIVITY EDWARDS AIR FORCE BASE, CALIFORNIA 93523 | | 11. REPORT DATE Jan 1976 |
| | | 13. NUMBER OF PAGES 12 185 P. |
| 14. MONITORING AGENCY NAME & ADDRESS (if different from Controlling Office) 14 USAAEFA-75-10 | | 15. SECURITY CLASS. (of this report) UNCLASSIFIED |
| | | 15a. DECLASSIFICATION/DOWNGRADING SCHEDULE NA |
| 16. DISTRIBUTION STATEMENT (of this Report) Approved for public release; distribution unlimited | | |
| 17. DISTRIBUTION STATEMENT (of the abstract entered in Block 20, if different from Report) DDC RECEIVED DEC 14 1977 E | | |
| 18. SUPPLEMENTARY NOTES | | |
| 19. KEY WORDS (Continue on reverse side if necessary and identify by block number) Airworthiness qualification Infrared suppressors U-21A airplane Flying qualities and performance base-line data Acrylic lacquer low reflective paint Performance degradation | | |
| 20. ABSTRACT (Continue on reverse side if necessary and identify by block number) → The United States Army Aviation Engineering Flight Activity conducted an airworthiness qualification evaluation of a U-21A airplane painted with acrylic lacquer low reflective (LR) olive drab paint and with infrared (IR) hot metal suppressors installed. The evaluation was accomplished in three phases between 25 June and 17 September 1975 to establish a flying qualities and performance base line for the basic U-21A and then to separately determine the degradation (contd) → | | |

UNCLASSIFIED

SECURITY CLASSIFICATION OF THIS PAGE(When Data Entered)

20. Abstract

due to the application of LR paint and the installation of the IR suppressors. During the test program 47 productive test flight hours were flown. Performance, stability and control characteristics, and miscellaneous engineering tests were conducted. During these tests no deficiencies and ten handling qualities shortcomings (not a result of the LR paint or IR suppressor installation) were noted. In general, the most significant changes resulting from the addition of LR paint were the 3-knot indicated airspeed (KIAS) increase in stall airspeed, the slight reduction in the pitot-static source position error, and a minor performance degradation. The combination of LR paint and IR suppressors resulted in an additional 3-KIAS airspeed increase in stall airspeed (total of 6 KIAS) and sufficient degradation in performance to warrant recommending the publication of an IR performance supplement to the operator's manual, using the data for the U-21A with all IR modifications as a basis and annotating it for use by all LR-painted U-21A airplanes, with and without IR suppressors installed. Because of the deterioration of the IR suppressor surface coating material and the vibrations of the suppressors in flight, it was recommended that the release of the IR suppressors be limited to operational necessity until further reliability tests had been conducted. Measurements were made to determine the standard exhaust stub and IR suppressor surface and exhaust gas stream temperatures in flight. The results were reported in a separate classified addendum (Report No. 75-10-1) to this report.

| | |
|---------------------------------|---|
| ACCESSION for | |
| NTIS | White Section <input checked="" type="checkbox"/> |
| DDC | Buff Section <input type="checkbox"/> |
| UNANNOUNCED | <input type="checkbox"/> |
| JUSTIFICATION | |
| BY | |
| DISTRIBUTION/AVAILABILITY CODES | |
| Dist. | AIR and/or SPECIAL |
| A | |

UNCLASSIFIED

SECURITY CLASSIFICATION OF THIS PAGE(When Data Entered)



DEPARTMENT OF THE ARMY
HQ, US ARMY AVIATION RESEARCH AND DEVELOPMENT COMMAND
P O BOX 209, ST. LOUIS, MO 63166

DRDAV-EQ

NOV 15 1977

SUBJECT: Directorate for Development and Engineering Position on the Conclusions and Recommendations of the Final Report on USAAEFA Project No. 75-10, Airworthiness Qualification Evaluation U-21A Airplane with Low Reflective Paint and Hot Metal Suppressors, dated January 1976

SEE DISTRIBUTION

1. The Directorate for Development and Engineering position on USAAEFA's conclusions and recommendations is provided herein. Paragraph numbers from the subject report are provided for reference.
2. Paragraphs 80b, c, and d. A change in airspeed position error between the flights made with the basic and painted aircraft and a difference in the position error of the test aircraft and that presented in the Operator's Manual were reported. The conclusions reached regarding take-off distance are based on take-offs made at the same indicated airspeed and in the presence of this change are misleading. When the take-off distances are compared on the basis of calibrated airspeed, the basic U21A ground roll is only approximately 140 feet longer than that presented in the referenced 1972 Operator's Manual, not 400 feet as stated in the report. Also on a calibrated airspeed basis, the addition of LR paint and IR suppressors increases take-off distance approximately 300 feet, not 100 feet as stated in the report.
3. Paragraph 80s. The conclusion that the pitot static source position error was reduced by the application of LR paint is seriously questioned. The basic aircraft with standard paint airspeed calibration presented in the report is suspect, as it does not agree with the position error presented in the Operator's Manual which is based on previous contractor and Government test data. The LR painted aircraft position error is within one knot of the Operator's Manual values which is a logical change.
4. Paragraphs 81 and 83. The shortcomings outlined in paragraph 81 deal with the easily excited phugoid mode, persistent Dutch Roll, low stick forces, stall warning, trim during gear retraction, field of view, and ineffective lateral trim. These shortcomings are considered minor in nature and typical of aircraft procured off the shelf. The effort required to overcome them is not justified. Agree with the recommendation that these shortcomings be corrected in future designs.

NOV 15 1977

DFFAV-EQ

SUBJECT: Directorate for Development and Engineering Positions on the Conclusions and Recommendations of the Final Report on USAAEFA Project No. 75-10, Airworthiness Qualification Evaluation U-21A Airplane with Low Reflective Paint and Hot Metal Suppressors, dated January 1976

5. Paragraph 82. The release of the IR suppressor design tested has been restricted as recommended. IR suppressors of an improved design are undergoing airworthiness qualification, therefore additional testing of the original design would not be meaningful.

6. Paragraph 84. The V_{MC} chart (Figure 57 of Appendix F) is not a valid presentation of minimum control speed and incorporation of this chart in the Operator's Manual is not contemplated. Minimum single engine control speed is a function of temperature, pressure altitude, and calibrated airspeed. Table 3 of the subject report indicates testing was accomplished at several temperatures and altitudes, and other data presented indicate changes in airspeed position error with changes in configuration. Thus Figure 57, which presents V_{MC} based on indicated airspeed and density altitude, is invalid since engine power is a function of pressure and temperature, not density. It should be noted that the Operator's Manual referenced in the subject report and those for all of the U-21 series aircraft have been replaced by manuals in the new MIL-N-63029A format. These new manuals present V_{MC} as a function of temperature and pressure altitude. Action is being taken to use applicable data from the subject report to update the data presented in the Operator's Manuals to reflect dynamic V_{MC} and adequate warnings concerning flight below these speeds.

7. Paragraph 85a. The present Operator's Manual procedures which provide for approach with less than full flaps, and the use of crab attitude to correct for drift are considered acceptable. These procedures provide a good balance between minimum landing distance and aircraft handling qualities. The suggested change is not contemplated.

8. Paragraphs 85b and c. Action is being taken to include the recommended cautions on maneuvering with flaps extended and flight at less than zero g in the Operator's Manual.

9. Paragraph 87a, b, and c. Action is being taken to include the recommended change in Operator's Manual minimum run landing instructions.

10. Paragraph 87g and h. The power-off stall speed graph presented in the "new format" Operator's Manual is based on contractor test and this graph and accompanying text are considered adequate.

11. Paragraph 87j and 88a. Action is being taken to initiate testing to develop minimum run take-off techniques and investigate effect of lift off speed on pilot workload.

NOV 15 1977

DRDAV-EQ

SUBJECT: Directorate for Development and Engineering Position on the Conclusions and Recommendations of the Final Report on USAAEFA Project No. 75-10, Airworthiness Qualification Evaluation U-21A Airplane with Low Reflective Paint and Hot Metal Suppressors, dated January 1976

12. Paragraph 89. Control measures to insure uniform standards of paint application have been established.

FOR THE COMMANDER:

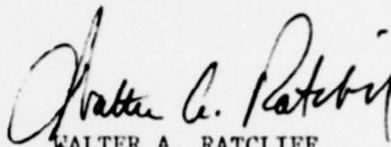

WALTER A. RATCLIFF
Colonel, GS
Director of Development
and Engineering

DISTRIBUTION:

Same as USAAEFA U-21A Airplane
Report Project No. 75-10

TABLE OF CONTENTS

| | <u>Page</u> |
|---|-------------|
| INTRODUCTION | |
| Background | 3 |
| Test Objectives | 3 |
| Description | 3 |
| Test Scope | 4 |
| Test Methodology | 8 |
| RESULTS AND DISCUSSION | |
| General | 9 |
| Performance | 9 |
| General | 9 |
| Takeoff and Landing Performance | 9 |
| Climb Performance | 11 |
| Level Flight Performance | 12 |
| General | 12 |
| Dual-Engine | 12 |
| Single-Engine | 14 |
| Stall Performance | 14 |
| Handling Qualities | 16 |
| General | 16 |
| Level Flight Trim | 16 |
| Static Longitudinal Stability | 17 |
| Static Lateral-Directional Stability | 17 |
| Dynamic Longitudinal Stability | 19 |
| Short-Period Characteristics | 19 |
| Phugoid Characteristics | 19 |
| Dynamic Lateral-Directional Stability | 22 |
| Dutch-Roll Characteristics | 22 |
| Spiral Stability | 22 |
| Maneuvering Stability | 22 |
| Roll Performance | 25 |
| Stall Characteristics | 26 |
| General | 26 |
| Stall Warning | 26 |
| Stalls | 28 |
| Unaccelerated Stalls | 28 |
| Accelerated Stalls | 29 |
| Single-Engine Stalls | 29 |
| Stall Recovery | 29 |

| | <u>Page</u> |
|--|-------------|
| Single-Engine Characteristics | 30 |
| Static Single-Engine Minimum Control Airspeed | 31 |
| Dynamic Single-Engine Minimum Control Airspeed | 31 |
| Takeoff and Landing Characteristics | 32 |
| Trimmability | 34 |
| Subsystem Tests and Modification Evaluation | 34 |
| Engine Performance | 34 |
| Infrared Suppressors | 35 |
| Vibration | 35 |
| Reliability | 36 |
| Low Reflective Paint | 41 |
| Pitot-Static Source Position Error | 44 |

CONCLUSIONS

| | |
|------------------------|----|
| General | 46 |
| Shortcomings | 47 |

RECOMMENDATIONS 49

APPENDIXES

| | |
|--|-----|
| A. References | 53 |
| B. Description | 54 |
| C. Instrumentation | 67 |
| D. Test Techniques and Data Analysis Methods | 74 |
| E. Handling Qualities Rating Scale | 88 |
| F. Test Data | 89 |
| G. Drag Polar Coefficient Tables | 173 |
| H. List of Symbols and Abbreviations | 177 |

DISTRIBUTION

INTRODUCTION

BACKGROUND

1. Hughes Helicopter Company was tasked by contract to design and fabricate suppressors for the T74-CP-700 engine to provide the U-21A aircraft with increased survivability from the infrared (IR) and heat-seeking missile threat. Beech Aircraft Corporation (BAC) conducted a 10-week flight test evaluation of the U-21A equipped with the Hughes IR suppressor. The United States Army Aviation Engineering Flight Activity (USAAEFA) was then tasked by the United States Army Aviation Systems Command (AVSCOM) (ref 1, app A) to conduct an airworthiness qualification evaluation on the U-21/RU-21 T74-CP-700 engine series IR suppressors.

TEST OBJECTIVES

2. The objectives of the airworthiness qualification evaluation were as follows:
- a. Establish the basic U-21A performance and handling qualities data.
 - b. Determine any changes due to the addition of low reflectivity (LR) paint.
 - c. Perform an airworthiness qualification evaluation of the IR suppressors.
 - d. Provide data and operational techniques for inclusion in the operator's manual (ref 2, app A).
 - e. Obtain preliminary reliability data of the exhaust hot metal IR suppressor construction and material.

DESCRIPTION

3. The test aircraft, serial number 66-18008, was a production U-21A, which for a portion of the tests was modified by the addition of LR paint (NSN 8010-00-083-6588; MIL-L-46159) covering the aircraft's normally painted exterior surfaces (excluding propellers) and the substitution of aluminum engine IR exhaust hot metal suppressors (IR suppressors) for the standard engine exhaust stacks. The IR suppressors were manufactured by Hughes Helicopter Company according to top drawing No. M30295. (Part numbers and top drawing numbers are the same.) Paint was not applied to the static ports or the normally polished circular metal surface which comprises the static port. The basic U-21A airplane is an unpressurized low wing all-metal aircraft with retractable tricycle landing gear. Power is provided by two T74-CP-700 turboprop engines, each rated at 550 shaft horsepower (shp) at standard-day, sea-level static conditions. Appendix B contains

a more detailed description of the U-21A test aircraft, including photographs with and without LR paint and suppressors installed. Additional information on the U-21A is contained in the operator's manual.

TEST SCOPE

4. A quantitative and qualitative flying qualities and performance evaluation was conducted by USAAEFA at Edwards Air Force Base, California, from 24 June through 17 September 1975. During the test program 33 flights were conducted for a total of 63.7 test flight hours, of which 47 hours were productive. The airplane was tested in three phases: (a) basic, (b) with LR paint applied, and (c) with LR paint and IR suppressors installed. The three configurations were evaluated and the results compared to determine any changes due to the addition of the paint and suppressors. Test configurations are shown in table 1 and average test conditions are shown in tables 2, 3, and 4. Flight restrictions and operating limitations applicable to this evaluation are contained in the operator's manual. Flight tests were conducted in compliance with the safety-of-flight release (ref 3, app A).

Table 1. Test Configurations.

| Configuration | Gear Position | Flaps (%) | Power Setting | Propeller Speed (rpm) |
|---------------------|---------------|-----------|-------------------|-----------------------|
| Takeoff (TO) | Down | Zero | TO ¹ | 2200 |
| Climb (CL) | Up | Zero | NRCP ² | 2000 |
| Cruise (CR) | Up | Zero | PLF ³ | 1900 |
| Power approach (PA) | Down | 35 | PLF | 2000 |
| Landing (L) | Down | 100 | Idle | 2200 |
| Glide (G) | Up | Zero | Engines off | Note ⁴ |
| Wave-off (WO) | Down | 100 | TO | 2200 |

¹TO: Takeoff power (see app B).

²NRCP: Normal rated climb power (see app B).

³PLF: Power for level flight.

⁴Propellers feathered and stopped.

Table 2. Performance Test Conditions.

| Test | Test Phase | Density Altitude (ft) | Outside Air Temperature (°C) | Gross Weight (lb) | Center-of-Gravity Location (in.) | Indicated Airspeed Range (kt) | Configuration |
|--|-------------------------|-----------------------|------------------------------|-------------------|----------------------------------|-------------------------------|----------------------|
| Takeoff | B ¹ | 3150 | 19 | 9640 | 153.5 (fwd) | 83 to 105 | TO |
| | P + S ² | 3210 | 19 | 9650 | 153.4 (fwd) | 85 to 110 | TO |
| Dual-engine climbs and propeller-feathered sinks | B | 12,160 | 11 | 9010 | 150.5 (fwd) | 80 to 180 | CR, TO |
| | B | 11,850 | 15.5 | 9290 | 153.0 (fwd) | 90 to 198 | CR, TO |
| | B | 11,820 | 12 | 9180 | 152.5 (fwd) | 90 to 208 | CR, TO |
| | P ³ | 11,590 | 10 | 9370 | 153.0 (fwd) | 101 to 208 | CR, TO |
| | P + S | 11,170 | 7.5 | 9230 | 153.0 (fwd) | 100 to 208 | CR, TO |
| | P w/o inst ⁴ | 10,840 | 2.5 | 8000 | 150.5 (fwd) | 99 to 170 | CR, TO |
| | B | 11,930 | 12 | 9290 | 153.0 (fwd) | 90 to 186 | CR, TO |
| Dual-engine speed powers | B | 11,200 | 5 | 9160 | 153.0 (fwd) | 90 to 180 | CR |
| | B | 7590 | 28 | 9290 | 153.0 (fwd) | 90 to 190 | CR |
| | P + S | 10,950 | 4 | 9290 | 153.0 (fwd) | 90 to 175 | CR, TO |
| | P w/o inst | 11,000 | 3 | 7870 | 150.5 (fwd) | 91 to 185 | CR |
| Single-engine speed powers | B | 9110 | 19 | 9210 | 153.0 (fwd) | | CR |
| | P + S | 8370 | 14 | 9380 | 153.0 (fwd) | 95 to 120 | CR |
| Single-engine climb | B | 8990 | 19.5 | 9030 | 152.5 (fwd) | | CR |
| | P + S | 8390 | 14 | 9200 | 152.5 (fwd) | 95 to 110 | CR |
| Stall performance | B | 12,070 | 14.5 | 9270 | 159.9 (aft) | | |
| | P | 11,760 | 10.5 | 9150 | 159.6 (aft) | ---- | CR, TO, PA, L, WO |
| | P + S | 11,570 | 9 | 9220 | 159.6 (aft) | | |
| Landing performance | P + S | 3100 | 18.5 | 9650 | 160.2 (aft) | 110 to 90 | TO |

¹B: Basic U-21A.²P + S: LR-painted U-21A with IR suppressors installed.³P: LR-painted U-21A.⁴P w/o inst: LR-painted U-21A without pitot-static boom.

Table 3. Handling Qualities Test Conditions.

| Test | Test Phase | Density Altitude (ft) | Outside Air Temperature (°C) | Gross Weight (lb) | Center-of-Gravity Location (in.) | Indicated Trim Airspeed (kt) | Configuration |
|--|------------|-----------------------|------------------------------|-------------------|----------------------------------|------------------------------|-------------------|
| Static longitudinal stability | B | 11,730 | 12 | 9320 | 160.0 (aft) | 180, 138, 120 | CR, PA |
| | P + S | 10,880 | 7.5 | 9200 | 159.5 (aft) | 180, 140, 120 | CR, PA |
| Static lateral-directional stability | B | 11,640 | 12 | 8920 | 159.0 (aft) | 182, 142, 119 | CR, PA |
| | P + S | 11,030 | 7 | 8830 | 159.0 (aft) | 176, 140, 120 | CR, PA |
| Dynamic stability | B | 12,400 | 12 | 8920 | 159.0 (aft) | 160, 141, 120 | CR, PA |
| | P + S | 11,260 | 8 | 8980 | 159.0 (aft) | 160, 140, 120 | CR, PA |
| Maneuvering stability | B | 11,920 | 11.5 | 9060 | 159.2 (aft) | 170, 140 | CR |
| | P + S | 11,730 | 10 | 9080 | 159.0 (aft) | 160, 140, 120 | CR, PA |
| Roll performance | B | 12,400 | 12 | 8920 | 159.0 (aft) | 161, 141, 120 | CR, PA |
| | P + S | 11,260 | 8 | 8980 | 159.0 (aft) | 160, 140, 120 | CR, PA |
| Stall characteristics | B | 12,070 | 14.5 | 9270 | 159.9 (aft) | ----- | CR, TO, PA, L, WO |
| | P | 11,760 | 10.5 | 9150 | 159.6 (aft) | ----- | |
| Single-engine minimum-control airspeed | P + S | 11,570 | 9 | 9220 | 159.6 (aft) | ----- | |
| | B | 12,170 | 14.5 | 8400 | 152.0 (mid) | ----- | |
| | B | 9870 | 21 | 8620 | 150.1 (mid) | ----- | |
| | P | 11,610 | 9 | 7820 | 151.5 (mid) | ----- | |
| | P | 9310 | 16 | 7560 | 150.5 (mid) | ----- | |
| | P + S | 11,610 | 9 | 7990 | 152.0 (mid) | ----- | CR, TO, WO |
| | P + S | 9310 | 16 | 7730 | 151.0 (mid) | ----- | |
| | P + S | 7030 | 23 | 7610 | 150.5 (mid) | ----- | |

Table 4. Miscellaneous Engineering Test Conditions.

| Test | Test Phase | Density Altitude (ft) | Outside Air Temperature (°C) | Gross Weight (lb) | Center-of-Gravity Location (in.) | Test Indicated Airspeed (kt) | Configuration |
|-------------------------------------|--------------------------|-----------------------|------------------------------|-------------------|----------------------------------|------------------------------|------------------------|
| Airspeed calibration | B | 11,930 | 11 | 9100 | 152.5 (fwd) | 77 to 177 | CR, PA, WO |
| | P | 12,000 | 12 | 8390 | 151.5 (fwd) | 86 to 180 | CR, PA, WO |
| Thrust stand runs | --- | 3550 | 20 | NA | NA | Static | Note ¹ |
| Temperature measurements | B | 11,770 | 10.5 | 9360 | 153.0 (fwd) | 180, 130, 120, 100 | CR, PA, L ² |
| | B | 12,600 | 6 | 8200 | 150.0 (fwd) | 160, 130 | CR, L ² |
| | B and P + S ¹ | 3550 | 20 | NA | NA | Static | Note ¹ |
| | P + S | 11,610 | 9 | 9160 | 153.0 (fwd) | 180, 130, 170, 100 | CR, PA, L |
| Vibration measurements ³ | P + S | 8360 | 14 | 9380 | 153.0 (fwd) | 100 | WO |
| | P + S | 11,610 | 9 | 9160 | 152.7 (fwd) | 140 | CR |
| | P + S | 3550 | 20 | 9600 | 153.3 (fwd) | Zero to 140 | TO |
| | P + S | 11,570 | 9 | 9210 | 159.6 (aft) | 98 to 180 | CR, PA, TO, WO, L |

¹Separate thrust stand runs were made with standard exhaust stubs and IR suppressors installed.

²Rolls of 45 degrees left and right were also made in the PA and L configurations.

³Propeller speed was varied from 1800 to 2200 rpm.

TEST METHODOLOGY

5. Established flight test techniques and data reduction procedures were used during this program (refs 4 through 7, app A). The test methods are described briefly in the Results and Discussion section of this report. Flight test data were recorded on a magnetic tape unit located in the center cabin area of the aircraft. Additional flight test data were recorded by hand from test instrumentation installed in the pilot, copilot, and auxiliary instrument panels. A detailed list of the test instrumentation is contained in appendix C. Takeoff flight path data were recorded by two Fairchild Flight Analyzers. Test techniques, weight and balance, and data reduction procedures are contained in appendix D. A Handling Qualities Rating Scale (HQRS) (app E) was used to augment pilot comments relative to handling qualities. Airspeed calibrations were obtained by using space positioning radar and a calibrated F-51D pace aircraft. Deficiencies and shortcomings are in accordance with the definitions presented in Army Regulation 70-10.

RESULTS AND DISCUSSION

GENERAL

6. Performance and handling qualities of the U-21A aircraft were evaluated for the basic airplane, the airplane with LR paint applied, and after addition of IR suppressors to the LR-painted airplane. Each configuration was evaluated under a variety of operating conditions near the military maximum gross weight of 9650 pounds. Performance degradation because of the addition of LR paint and IR suppressors warrants publishing a supplement to the operator's manual covering the changed performance of the airplane. No deficiencies and ten handling qualities shortcomings were identified. Temperature measurements were made to evaluate the IR suppressor effectiveness and wing and nacelle heating effects. The results of these measurements are discussed in a separate classified addendum to this report (Project No. 75-10-1).

PERFORMANCE

General

7. The U-21A airplane was evaluated at the military maximum gross weight of 9650 pounds at the forward center-of-gravity (cg) limit (fuselage station (FS) 153.17). The drag polars of the airplane in each configuration (basic, LR-painted, and LR-painted with IR suppressors installed) were used to calculate the degradation to performance because of those external modifications. The addition of LR paint and installation of IR suppressors to the airplane slightly degraded the performance of the basic U-21A in all areas tested.

Takeoff and Landing Performance

8. Limited takeoff performance tests were conducted from a 5000-foot asphalt runway at General William J. Fox Airfield, Lancaster, California (elevation 2347 feet). Takeoff test conditions are presented in table 2. After each takeoff and landing, ballast was added to offset fuel consumed in order to maintain a constant weight and cg for each takeoff. All takeoffs were made using the maximum performance technique. The brakes were released after takeoff power had been developed and stabilized for 5 seconds. Takeoff power was maintained throughout the takeoff sequence. Rotation for nose wheel lift-off was started at 3 to 5 knots indicated airspeed (KIAS) prior to the desired lift-off airspeed, the landing gear was retracted immediately upon lift-off, and the lift-off airspeed maintained during the climb-out. All takeoffs were recorded on the on-board magnetic tape instrumentation and by two Fairchild Flight Analyzers. Surface winds were recorded for each takeoff, using a calibrated wind sensor located 50 feet from the start point on the runway. Test results are presented in figure 1, appendix F.

9. The operator's manual takeoff distance chart is not representative of takeoff performance. The actual takeoff ground roll and obstacle clearance distances for the basic U-21A were approximately 400 feet longer than those presented in the operator's manual. Because of this large disparity the following NOTE should be incorporated in the operator's manual until such time as the takeoff distance chart is corrected. In addition, further testing should be accomplished as soon as possible to develop accurate takeoff performance charts, to include distances for minimum-run takeoffs with one-half flaps.

NOTE

Add 400 feet to all takeoff distances computed from the takeoff performance charts for the basic U-21A.

10. The addition of LR paint and IR suppressors to the basic airplane increased the ground roll distance by 50 feet and the air distance to clear a 50-foot obstacle by 30 feet (total of 80 feet). Variations in operational pilot technique will cause variations in the takeoff distance on the same order of magnitude as those caused by the addition of LR paint and IR suppressors to the airplane. However, the operator's manual should include the following NOTE both in the description of normal takeoff techniques and on the takeoff charts.

NOTE

For aircraft painted with low reflectivity paint, with and without IR suppressors installed, an additional 100 feet should be added to all distances computed from the corrected takeoff performance chart.

11. The landing performance of the basic and externally modified airplane was estimated during each landing, and the landing distance charts as presented in the operator's manual were found to be representative of the actual airplane performance. The addition of LR paint and IR suppressors to the airplane had no effect on the landing performance. Several minimum-run landings were made using two different procedures and the techniques outlined in the operator's manual. Landings were made with the engine condition levers at low idle and high idle. With the condition levers at high idle prior to touchdown, landing distances were shorter than those attempted with condition levers at low idle. Placing the engine condition levers to high idle prior to touchdown prevented the engines from decelerating below 70 percent gas producer speed, shortened the time required to produce maximum reverse thrust, and eliminated dangerous airplane swerve tendencies due to unequal engine acceleration. The following changes should be incorporated in the operator's manual:

- a. The last two sentences in the Normal Operation section entitled **Minimum Run Landing** should be changed to read:

For maximum reverse propeller thrust, place the engine condition levers to HI IDLE as part of the final landing check. Return to Beta range when reverse is no longer needed and place the condition levers to LO IDLE.

- b. The following check should be added to the landing checklist:
 3. Condition levers - HI IDLE (for minimum run landing only).
- c. The after-landing checklist should be amended to read:
 1. Condition levers - LO IDLE.

12. Within the scope of this test, the takeoff and landing performance of the basic, LR-painted, and LR-painted and IR suppressor-configured U-21A airplane is satisfactory.

Climb Performance

13. Both dual- and single-engine climb performance were evaluated at the conditions shown in table 2, using the sawtooth-climb method of test. All dual-engine climbs were conducted with both engines operating at normal rated climb power. All single-engine climb tests were conducted with the left engine shut off, the propeller feathered, the right engine operating at normal rated climb power, and the aircraft banked 5 degrees into the good engine. Zero sideslip was maintained on the dual-engine climbs. Test results are presented in figures 2 through 5, appendix F. The climb drag polars for each of the configurations are presented in tables 1 and 2, appendix G.

14. The standard-day dual-engine climb capability at 10,000 feet and 9650 pounds gross weight, as presented in figure 2, appendix F, was degraded by 7.6 percent (95 feet per minute) (ft/min) by the addition of LR paint and IR suppressors. This degradation of climb rate would add approximately 0.5 minute to the time to climb to 10,000 feet from sea level. The airspeeds for best angle of climb and best rate of climb were essentially unchanged (only 3 knots true airspeed (KTAS) difference between the basic and LR-painted airplane with IR suppressors installed). The calculated rate of climb, as presented in figure 3, indicated a 5-percent degradation (55 ft/min) and the same 3-KTAS difference in best rate of climb airspeeds. Single-engine rate of climb at 5000 feet and 9650 pounds gross weight was decreased by 27 percent (70 ft/min) by the addition of LR paint and suppressors. This decrease represents a loss in single-engine service ceiling of 2000 feet or a reduction in payload of 400 pounds to maintain the original service ceiling. The single-engine best rate of climb airspeed was essentially unchanged (only 3 KTAS difference). The rate of climb for both the basic U-21A and the U-21A with all IR modifications was sensitive to small changes in rudder or aileron surface

movements. The additional drag caused by even small increased surface deflection at low airspeeds was enough to cause a significant rate of climb reduction. Within the scope of this test, the dual- and single-engine climb performance of the U-21A airplane with LR paint applied and IR suppressors installed is satisfactory. The IR supplement to the operator's manual should be based on the data for the LR-painted U-21A with IR suppressors installed, and should be used by all IR-configured aircraft.

Level Flight Performance

General:

15. The level flight performance of the U-21A was evaluated at the conditions and configurations presented in table 2. The engine-off propeller-feathered glide test method was used to obtain the power-off drag polars for the basic airplane and for the aircraft after LR paint and IR suppressor installation. The aircraft was stabilized and trimmed at incremental airspeeds in a descent with both engines shut off and the propellers feathered. The constant pressure altitude technique was used for power-on single-engine (propeller feathered) and dual-engine speed power polar determination. The aircraft was stabilized and trimmed at incremental airspeeds from the maximum airspeed for level flight (V_H) to near stall airspeed ($1.1V_S$). The level flight drag polar coefficients for each configuration are presented in tables 3 and 4, appendix G. Performance at conditions not specifically tested was calculated using drag polars and specification power-available data which included accessory losses. The specification engine, as defined by United Aircraft of Canada Ltd (UACL), is an engine ready for overhaul (degraded fuel consumption and power available). For this reason, the fuel flow and power available dependent performance calculations are conservative. The results of these tests are presented in figures 6 through 11, appendix F.

Dual-Engine:

16. The LR paint and IR suppressor effects on range and endurance for level flight in the CR configuration at 10,000 feet, at standard conditions and a maximum gross weight of 9650 pounds, are summarized in tables 5 and 6. The combined effect of paint and suppressors on range and endurance is relatively minor, in that the total range will be shortened by only 5.9 percent and endurance by 3.4 percent. The V_H at maximum gross weight was reduced by 8.5 KTAS in the LR-painted configuration with IR suppressors installed.

17. The current operator's manual basic airplane range and endurance summaries are satisfactory and should remain unchanged for the basic U-21A, except for the Specific Range Chart (fig. 14-26 in the manual), on which the true airspeed scale is in error by approximately 20 KTAS and should be corrected. Because of the relatively minor individual effects of the LR paint and the IR suppressors on the overall airplane performance, the IR performance supplement to the operator's manual should contain level flight performance charts based on the combined effect.

Table 5. Dual-Engine Level Flight Range Performance Summary.¹

| Data Basis | True Airspeed ² (kt) | Specific Range ³ | Maximum Range ⁴ |
|--|---------------------------------|-----------------------------|----------------------------|
| Operator's manual | 177 | .430 | 931 |
| Basic U-21A (test) | 181 | .426 | 922 |
| LR-painted U-21A | 177 | .413 | 894 |
| U-21A with LR paint and IR suppressors | 175 | .401 | 868 |

¹Based on calculations using specification engine and flight test drag polars corrected to standard conditions at 10,000 feet density altitude and a constant 9650-pound gross weight.

²Recommended cruise airspeed selected at 99 percent of maximum specific range, high airspeed side.

³Specific range in nautical air miles per pound of fuel.

⁴Maximum range in nautical miles.

Table 6. Dual-Engine Level Flight Endurance Performance Summary.¹

| Data Basis | True Airspeed ² (kt) | Specific Range ³ | Endurance ⁴ (hr) |
|--|---------------------------------|-----------------------------|-----------------------------|
| Operator's manual | 121 | .3815 | 6.82 |
| Basic U-21A (test) | 115 | .3485 | 6.56 |
| LR-painted U-21A | 117 | .3485 | 6.45 |
| U-21A with LR paint and IR suppressors | 118 | .3455 | 6.34 |

¹Based on calculations using specification engine and flight test drag polars corrected to standard conditions at 10,000 feet density altitude and a constant 9650-pound gross weight.

²Airspeed for maximum endurance selected at 101 percent minimum thrust shp required, high airspeed side of the curve.

³Specific range in nautical air miles per pound of fuel.

⁴Endurance in hours, based on flight using 2165 pounds of fuel with 10 percent reserve.

Single-Engine:

18. The flight test data for the single-engine level flight tests are presented in figures 9 and 10, appendix F. A comparison of effects at standard conditions is presented in figure 11. The combined effects of LR paint and IR suppressors degraded the single-engine range by 2.6 percent and endurance of the U-21A by 6 percent, and should be used as a basis for publishing the single-engine level flight data supplement to the operator's manual for the LR-painted and IR suppressor-configured aircraft.

Stall Performance

19. Dual-engine stall performance was evaluated at the conditions presented in table 2. Stalls were initiated from the specified trim conditions by decelerating at approximately 1 knot per second until the aircraft stalled. Stall was defined as an uncontrollable roll or nose-down pitch. Test results are presented in figures 12 through 14, appendix F. Since no position error data were available in the airspeed range near stall, an assumption was made that in that flight regime the basic U-21A position error was identical to that shown in the operator's manual.

20. A representative sample of the normal power-off stall airspeed variation with gross weight for the basic, LR-painted, and LR-painted and IR suppressor configurations is presented in figure A for the CR configuration. Data from the operator's manual have been added for comparison purposes. The LR paint increased the stall airspeed, on the average, 2 KIAS for the CR and PA configurations and 3 KIAS for the L configuration. The addition of IR suppressors increased the stall airspeed an additional 3 KIAS. There is a 14-KIAS difference between the stall airspeed in the CR configuration presented in the operator's manual and that determined in flight testing the basic U-21A. This difference is the result of the definition of stall having been changed. When the U-21A operator's manual was published, BAC defined stall as buffet onset; they now define stall as an uncontrollable roll or nose-down pitch. For this reason, the data presented in figure 12, appendix F, should be included as a change to the operator's manual, with the following NOTE added both to the data and to the discussion of stall in the Flight Characteristics portion of the operator's manual. Also, the definition of stall airspeed as defined for this test should be included in the manual discussion.

NOTE

For airplanes painted with low-reflectivity paint, add 3 KIAS to the stall airspeed determined from the stall airspeed chart. For airplanes with both LR paint and IR suppressors installed, add 6 KIAS to the stall airspeed determined from the stall airspeed chart.

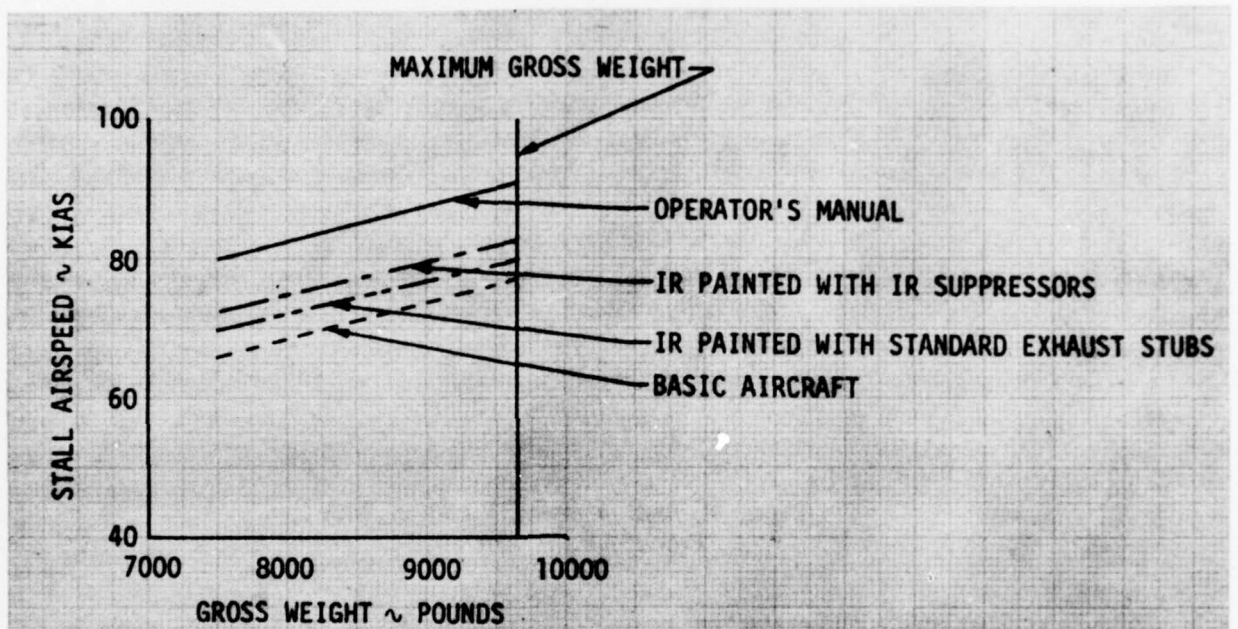

Figure A. Stall Airspeed Variation With Modification - Cruise Configuration.

21. Stall airspeed variation with power is presented in figure B for the basic U-21A. The stall airspeed variation with power and normal acceleration for the LR-painted, and LR-painted and IR suppressor-configured airplane was identical to that of the basic U-21A. A discussion of unaccelerated, accelerated, and single-engine stall characteristics is presented in paragraph 47. Within the scope of this test, the power-off, power-on, unaccelerated, and accelerated stall airspeeds are satisfactory for all configurations and external modifications of the U-21A airplane tested.

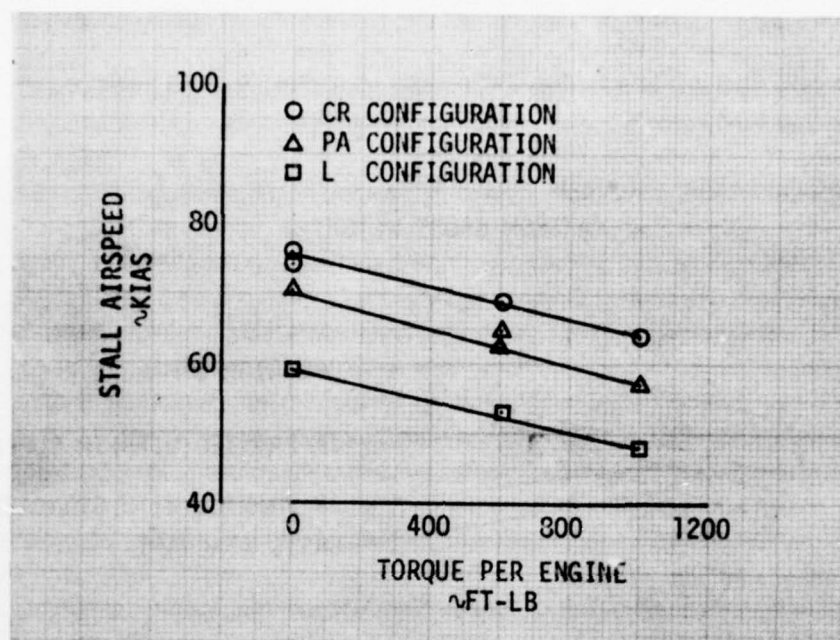

Figure B. Stall Airspeed Variation With Power - Basic Aircraft.

HANDLING QUALITIES

General

22. The handling qualities of the U-21A were evaluated before and after application of the LR paint and after installation of the IR suppressors. The handling qualities were evaluated under a variety of operating conditions, with emphasis on operation in the normal cargo configuration near the military maximum gross weight of 9650 pounds at the aft cg limit (FS 160.4). No deficiencies and 10 shortcomings were identified. The shortcomings are related to the poor stick-free maneuvering stability in the PA configuration at an aft cg, the lightly damped easily excited phugoid and Dutch-roll modes of the airplane, the ineffective lateral trim, and the premature artificial stall warning in the CR, TO, and PA configurations. None of the shortcomings are a result of the addition of LR paint and IR suppressors to the airplane.

Level Flight Trim

23. Control system positions in trimmed forward flight were evaluated at the conditions shown in table 3 and are presented in figures 15 and 16, appendix F. The requirement for left aileron throughout the airspeed range was attributed to the drag of the flight test pitot-static boom mounted on the right wing. Trimmed

aileron control position in level flight without the pitot-static boom showed an essentially neutral aileron position requirement at all airspeeds. Control system positions in trimmed forward flight were essentially unchanged by the addition of LR paint and IR suppressors to the airplane. Within the scope of this test, the control system positions in trimmed forward flight are satisfactory.

Static Longitudinal Stability

24. The static longitudinal stability characteristics of the U-21A airplane were evaluated at the conditions shown in table 3. The aircraft was trimmed in steady-heading, ball-centered level flight at the desired trim airspeed. At constant power, the aircraft was stabilized in 5-KIAS increments about the trim airspeed. Longitudinal control forces and positions were measured at each point. Test results for the basic aircraft and the LR-painted aircraft with IR suppressors installed are presented in figures 17 and 18, appendix F.

25. The stick-free static longitudinal stability, as indicated by the variation of control force with airspeed about a trim airspeed, was positive in both the CR and PA configurations. For the basic U-21A with an aft cg, control force gradients were more shallow on the low-speed side of trim than on the high-speed side. At airspeeds approaching a stall in the PA configuration, the control force gradient became essentially neutral. The control force gradients about all trim airspeeds increased slightly with the addition of LR paint and IR suppressors to the aircraft; however, this change was negligible and not apparent to the pilot. The near-neutral control force gradient at low airspeeds in the PA configuration was not objectionable to the pilot and the 2- to 3-pound force required was sufficient to discourage inadvertent excursions into stall.

26. The stick-fixed longitudinal static stability, as indicated by the variation of elevator control position with airspeed, was positive in the CR configuration, requiring 0.20 inch of displacement for a 37-KCAS change. In the PA configuration, the stick-fixed static stability was essentially neutral, with less than 0.10-inch displacement required to produce a 30-KCAS change in airspeed. In cruise flight the shallow control position gradients were not objectionable, due to the positive elevator force cues of airspeed variation from trim. Within the scope of this test, the static longitudinal stability of the U-21A in the CR configuration with LR paint and IR suppressors installed is satisfactory because of the adequate force cues. The aft cg limit as published in the basic U-21A operator's manual is satisfactory for operational use.

Static Lateral-Directional Stability

27. The static lateral-directional stability characteristics of the U-21A airplane were evaluated at the conditions shown in table 3. The aircraft was initially trimmed for zero sideslip at the desired airspeed. The aircraft was then stabilized at incremental sideslip angles left and right at constant airspeed and heading. Maximum

sideslip attained was limited in the PA configuration by a divergent Dutch roll and in the CR configuration by aileron control forces. Test results are presented in figures 19 through 24, appendix F.

28. Static directional stability, as indicated by the variation of sideslip angle with rudder pedal force, was positive and essentially linear for sideslips between 10 degrees left and right from trim. Addition of the LR paint and IR suppressors to the basic airplane only slightly increased the force gradients; however, the increases were not perceptible to the pilot in flight. In the CR configuration, the maximum sideslip attainable was limited by aileron forces (30 to 40 pounds). In the PA configuration, maximum sideslip was limited by a divergent Dutch roll. This oscillation had a damping ratio of $\delta_d = -0.029$ and an undamped natural frequency of $\omega_{nd} = 1.57$ radians/sec (0.25 Hz). This occurred at approximately 7-1/2 degrees angle of bank in the basic airplane and was not affected by the addition of LR paint and IR suppressors. A representative time history of this oscillation is presented in figure 25, appendix F. Recovery from this oscillation was immediately effected by decreasing rudder deflection. The oscillation presented no problem, in that it occurred at a point well beyond normal maneuvering limits; however, final runway alignment during approaches with crosswind components near the 21-knot limit required sideslips approaching the boundary of this oscillation. During these approaches the handling qualities of the airplane were improved by making the approach without flaps and maintaining an approach speed of 120 KIAS until just prior to touchdown. Because of the possibility of encountering this Dutch roll during crosswind approaches, the following CAUTION should be incorporated in the operator's manual.

CAUTION

Approaches with a crosswind component in excess of 15 knots should be made with the flaps up and with an approach speed of 120 KIAS maintained until just prior to touchdown.

29. Further evaluation of the static directional stability during aileron-only turns revealed that during normal maneuvering, the aircraft could be flown virtually as a two-control (aileron and elevator) airplane. During maneuvers simulating realignment with the runway after breaking out of the clouds on an instrument approach, only 2 to 3 degrees of adverse yaw were generated and minimal rudder coordination was required (HQRS 3).

30. Dihedral effect, as indicated by the variation of aileron control displacement with sideslip angle, was positive and essentially linear. Some pitch coupling was present, as indicated by the requirement for increasing aft elevator control displacement and force with increasing sideslip angles in both directions. Further evaluation using rudder-only turns confirmed strong dihedral effect, in that bank angle was easily controlled by small rudder displacements. Small heading changes were easily accomplished during approaches using rudders only (HQRS 2).

31. The side-force characteristics, as indicated by the variation of bank angle with sideslip angle, were positive and essentially linear for all configurations tested. The strong side-force characteristics provided the pilot good cues of out-of-trim flight conditions. Within the scope of this test, the static lateral-directional stability characteristics of the U-21A airplane with and without LR paint and IR suppressors installed are satisfactory.

Dynamic Longitudinal Stability

32. The dynamic longitudinal stability characteristics of the U-21A were evaluated at the conditions presented in table 3. The short-period dynamic characteristics were evaluated by elevator control pulses and doublets. The phugoid mode of motion was evaluated by trimming the airplane for hands-off level flight at the desired trim airspeed, stabilizing at 10 KIAS both above and below trim airspeed, and then releasing the control, allowing it to seek the trim position.

Short-Period Characteristics:

33. The short-period characteristics are summarized in table 7, with representative time histories presented in figures 26 through 28, appendix F. For all configurations and airspeeds tested, the short period appeared essentially deadbeat and the undamped natural frequency decreased with airspeed. The undamped natural frequency in the PA configuration was low, and in conjunction with the control system characteristics, affected the handling qualities of the airplane, as discussed in paragraphs 41 and 65. Within the scope of this test the short-period characteristics of the U-21A are satisfactory.

Phugoid Characteristics:

34. The phugoid characteristics of the U-21A are summarized in table 8. Representative time histories of the phugoid mode are presented in figures 29 through 32, appendix F.

35. The phugoid response of the U-21A was oscillatory, lightly damped, and easily excited in the CR configuration at 160 KIAS, and neutrally damped at 140 KIAS. In the PA configuration, the phugoid mode was divergent, as shown in figure 29, appendix F. However, since the pilot was normally tightly in the control loop during approaches, the negative damping of the phugoid had little effect on the airplane flying qualities in the PA configuration. The addition of LR paint and IR suppressors increased the damping and decreased the period of the phugoid slightly but not enough to be evident to the pilot. The long period, low damping, and ease of excitement of the phugoid in the CR configuration made long-term longitudinal trimmability of the airplane impossible to achieve. Airspeed variations of 3 to 5 KIAS were common in all flight regimes where the pilot was not tightly in the control loop to suppress the incipient phugoid oscillation. The lightly damped and easily excited phugoid mode will increase pilot workload during instrument flight and is a shortcoming which should be corrected in future designs.

Table 7. Short-Period Dynamic Stability Characteristics.

| Test Phase | Configuration | Calibrated Trim Airspeed (kt) | Damping Ratio (ζ_{sp}) | Undamped Natural Frequency | |
|--|---------------|-------------------------------|--------------------------------|----------------------------|-------|
| | | | | Radians/Second | Hertz |
| Basic U-21A | PA | 120 | 0.59 | 1.62 | 0.26 |
| U-21A with LR paint and IR suppressors | PA | 120 | 0.50 | 1.54 | 0.25 |
| Basic U-21A | CR | 140 | 0.59 | 2.59 | 0.41 |
| U-21A with LR paint and IR suppressors | CR | 140 | 0.40 | 2.74 | 0.44 |
| Basic U-21A | CR | 160 | 0.59 | 3.24 | 0.52 |
| U-21A with LR paint and IR suppressors | CR | 160 | 0.40 | 3.26 | 0.52 |

Table 8. Phugoid Characteristics.

| Test Phase | Configuration | Calibrated Trim Airspeed (kt) | Damping Ratio (ζ_p) | Undamped Natural Frequency (rad/sec) | Period (sec) |
|--|---------------|-------------------------------|-----------------------------|--------------------------------------|--------------|
| Basic U-21A | PA | 120 | -0.091 | 0.172 | 36.7 |
| U-21A with LR paint and IR suppressors | PA | 120 | -0.023 | 0.178 | 35.3 |
| Basic U-21A | CR | 140 | Zero | 0.141 | 44.5 |
| U-21A with LR paint and IR suppressors | CR | 140 | 0.035 | 0.151 | 41.5 |
| Basic U-21A | CR | 160 | 0.040 | 0.123 | 51.0 |
| U-21A with LR paint and IR suppressors | CR | 160 | 0.046 | 0.128 | 49.0 |

Dynamic Lateral-Directional Stability

Dutch-Roll Characteristics:

36. The dynamic lateral-directional stability characteristics were evaluated at the conditions presented in table 3. The Dutch-roll characteristics were evaluated by exciting the aircraft from a coordinated level flight trim condition with rudder pulses, rudder doublets, aileron pulses, and releases from steady-heading sideslips. Time histories of representative dynamic lateral-directional airplane responses are presented in figures 33 through 35, appendix F. Test results are summarized in table 9.

37. The Dutch roll was easily excited and tended to damp out in three to four cycles in smooth air. In the presence of turbulence, however, the Dutch roll persisted, was annoying to the pilot, and was extremely difficult to damp using primary flight controls (HQRS 5). The lightly damped, easily excited persistent Dutch roll in the presence of turbulence is objectionable and is a shortcoming. The LR paint and IR suppressors had no appreciable effect on the Dutch-roll characteristics of the U-21A airplane.

Spiral Stability:

38. The spiral stability characteristics of the U-21A were evaluated by establishing trimmed level flight conditions and then stabilizing in a 10-degree bank angle, using rudders only. After the bank angle was established, the rudder pedal was slowly returned to trim and the resulting tendency of the aircraft to increase or decrease bank angle noted. The basic U-21A exhibited neutral spiral stability in both left and right banked turns. Any small disturbance of the control system or gust could disturb this balance and cause the airplane to diverge or converge. The addition of LR paint and IR suppressors to the airplane made the spiral mode slightly convergent for all configurations and airspeeds tested. Within the scope of this test, the spiral stability of the U-21A with and without LR paint and IR suppressors installed is satisfactory.

Maneuvering Stability

39. Maneuvering stability characteristics were evaluated at the conditions presented in table 3. The variation of elevator control force and control position with normal acceleration was determined by trimming the aircraft in coordinated level flight at the desired trim airspeed and configuration and then stabilizing at incremental bank angles in both left and right turns. Airspeed was held constant and the aircraft allowed to descend during the maneuver. Data were obtained at each stabilized bank angle. Symmetrical pull-up and pushover maneuvers were also utilized to evaluate the aircraft maneuvering stability in level flight and to obtain data below 1.0g. The load factor was varied incrementally to the maximum allowable during the maneuvers. The results of the maneuvering stability evaluation for the basic U-21A and the U-21A with LR paint and IR suppressors installed are presented in figures 36 through 44, appendix F.

Table 9. Dutch-Roll Characteristics.

| Test Phase | Configuration | Calibrated Trim Airspeed (kt) | Damping Ratio (ζ_d) | Undamped Natural Frequency (rad/sec) | Period (sec) | Roll to Yaw Ratio (ϕ/β) |
|--|---------------|-------------------------------|-----------------------------|--------------------------------------|--------------|------------------------------------|
| Basic U-21A | PA | 120 | 0.10 | 1.64 | 3.85 | 1.32 |
| U-21A with LR paint and IR suppressors | PA | 120 | 0.11 | 1.63 | 3.90 | 1.33 |
| Basic U-21A | CR | 140 | 0.10 | 1.86 | 3.40 | 1.32 |
| U-21A with LR paint and IR suppressors | CR | 140 | 0.11 | 1.98 | 3.20 | 1.55 |
| Basic U-21A | CR | 160 | 0.10 | 2.18 | 2.90 | 1.51 |
| U-21A with LR paint and IR suppressors | CR | 160 | 0.10 | 2.25 | 2.80 | 1.67 |

40. The stick-free maneuvering stability, as indicated by the variation of elevator control force with normal acceleration, was positive and essentially linear for all conditions tested. The elevator control force gradients (stick force per g) were invariant with external airframe modification and are summarized in table 10. The stick-fixed maneuvering stability, as indicated by the variation of elevator control position with normal acceleration, was positive, essentially linear, and essentially constant at approximately 0.65-inch per g for all configurations tested.

Table 10. Maneuvering Stability Control Force Gradients.

| Maneuver | Configuration | Calibrated Trim Airspeed (kt) | Elevator Control Force Gradient (lb/g) |
|------------------------------------|---------------|-------------------------------|--|
| Symmetrical pull-ups | PA | 117 | 24 |
| Steady turns | PA | 117 | 24 |
| | CR | 140 | 38 |
| Symmetrical pull-ups and pushovers | CR | 140 | 32 |
| | CR | 171 | 32 |
| Steady turns | CR | 171 | 36 |

41. Buffeting in the CR configuration below the design maneuvering speed of 169 KCAS was encountered between 0.2g and 0.7g prior to the airframe structural limit, and provided an excellent cue of the approach of the aircraft limit load factor. In turns, the airplane consistently stalled prior to reaching the limit load factor. The maneuvering control forces in the CR configuration were high enough to prevent inadvertent control inputs which might give abrupt aircraft responses and to prevent exceeding the limit load factor in sudden panic maneuvers in all configurations except PA. Pitch and load factor response was also immediate and predictable in all configurations except the PA configuration. In the PA configuration, the low longitudinal stick force per g, coupled with the low undamped natural frequency of the short period, allowed the limit load factor of the airplane to be exceeded. In spite of extensive pilot compensation, the g limits were inadvertently exceeded (with flaps extended) by 0.25g and 0.15g during symmetrical pull-ups (HQRS 7). A time history of the airplane response to a 1/2-inch aft step input at 120 KIAS in the PA configuration is presented in figure 45, appendix F. The low stick force per g gradient in the PA configuration is a shortcoming. Although abrupt maneuvers and control movements are not a normal part of the U-21A operation, the following CAUTION should be included in the operator's manual.

CAUTION

Avoid large or abrupt elevator control movements when operating at an aft cg with the gear and flaps extended, as maneuver load factor limits for flaps-extended flight may be exceeded.

42. Load factors below $-0.5g$ were difficult to achieve because of high stick forces and engine surges. At $-0.5g$ the engine oil pressures, fuel pressures, torque, and power drastically dropped and the engines began decelerating because of lack of fuel. This situation will normally never be encountered by the operational pilot because it is difficult to achieve and is extremely uncomfortable for the pilot. However, the following CAUTION should be added to the Maneuvers paragraph of the Operating Limitations section of the operator's manual.

CAUTION

Load factors of less than $0.0g$ may cause dual-engine flameout due to fuel starvation.

43. Within the scope of this test, the maneuvering stability of the U-21A airplane in the CR configuration with LR paint and IR suppressors installed is satisfactory.

Roll Performance

44. Roll performance was evaluated at the conditions presented in table 3. These tests were initiated from a trimmed unaccelerated flight condition by applying both one-half deflection and full deflection aileron control inputs (in 0.2 second) without changing either elevator or rudder pedal control position. Test results are presented as representative time histories of airplane response with one-half and full deflection aileron inputs in figures 46 through 55, appendix F, and summarized for the full deflection rolls in figure 56.

45. The roll performance of the basic U-21A was satisfactory, with one-half aileron control deflection rolls developing only 2 degrees adverse yaw and only slightly exciting the Dutch-roll mode. Full aileron control deflection rolls developed 4 to 5 degrees maximum adverse yaw and again only slightly excited the Dutch-roll mode. Addition of LR paint to the airplane had a significant effect on the maximum roll rate developed and the handling qualities of the airplane. Adverse yaw increased significantly, more than doubling at the higher airspeeds (4 to 5-degree sideslips during one-half deflection rolls and 9 to 10 degrees with full deflection rolls). The significant increase in adverse yaw excited the Dutch-roll mode, making the roll rate highly oscillatory with roll rate reversal during the roll very apparent. The degraded roll performance after LR paint application is shown in figure 56, appendix F, in terms of the ratio of the oscillatory to average roll rate. The excitation of the Dutch roll decreased the average steady-state roll rate by as much as 10 degrees per second and increased the force necessary to obtain maximum aileron control deflection from 65 to 85 pounds. Pitch coupling with roll was

increased because of the increased magnitude of the Dutch roll; however, the maximum g attained was 2.2g at 160 KIAS and was not a significant factor in airplane control. The addition of IR suppressors had no effect on the roll performance of the U-21A.

46. The operational pilot will normally not encounter the poor roll handling qualities associated with full aileron deflection rolling maneuvers because the large control deflection (98 degrees) and control force (85 pounds) required to achieve maximum aileron control deflections are sufficient deterrent to discourage such maneuvers. Within the scope of this test, the roll performance characteristics of the U-21A with LR paint and IR suppressors added are satisfactory.

Stall Characteristics

General:

47. Dual- and single-engine stall characteristics of the U-21A airplane were evaluated at the conditions listed in table 3. Stalls were initiated from the specified trim conditions by decelerating at a rate of approximately 1 knot per second until the airplane stalled. Stall warning, stall, and stall recovery characteristics were evaluated qualitatively. Dual-engine stalls were evaluated with power off, partial power (600 foot-pounds torque per engine), and high power (1000 foot-pounds torque per engine). Single-engine stalls were evaluated with the critical engine (left engine) shut off, propeller feathered, and normal rated climb power on the remaining engine.

Stall Warning:

48. Initial stall warning for all stalls was provided by a stall warning horn triggered by a stall warning vane mounted in the leading edge of the left wing at wing station 231. The angle of attack for stall warning horn activation was virtually independent of either IR modification or power setting. The horn activated consistently at 14 degrees angle of attack in CR, 15 degrees in PA, and 16 degrees in the L configurations. Configuration, power, and external airplane modifications did, however, affect the stall warning margin, as shown in table 11.

49. Additional stall warning was provided by decreased control effectiveness and the extreme nose-high attitudes required to stall the airplane (15 to 20 degrees, power off, in the CR configuration and 25 to 30 degrees with power on). These extreme attitudes provided excellent cues of the approach of stall; however, these cues were degraded by the addition of flaps. The power-off stall in the L configuration occurred in a near-level attitude and only slightly nose high (5 to 10 degrees) with power addition. As shown in the "horn to stall" column of table 11, the inability of the artificial stall warning system to adjust with configuration change required that the system be adjusted to activate early in the CR, TO, and PA configurations so that it would provide adequate warning

Table 11. Stall Warning Margin.

| Configuration | Test Phase | Horn to Buffet | Buffet to Stall | Horn to Stall |
|-----------------|------------|--------------------------|-----------------|---------------|
| | | Knots Indicated Airspeed | | |
| CR/TO | B | 7 | 19 | 26 |
| | P | 7 | 17 | 24 |
| | P + S | 7 | 13 | 20 |
| CL ¹ | B | 16 | 10 | 26 |
| | P | 14 | 7 | 21 |
| | P + S | 14 | 4 | 18 |
| PA | B | 8 | 8 | 16 |
| | P | 6 | 10 | 16 |
| | P + S | 4 | 8 | 12 |
| L | B | 8 | 8 | 16 |
| | P | 5 | 9 | 12 |
| | P + S | 3 | 7 | 10 |
| WO ¹ | B | 13 | 3 | 16 |
| | P | 12 | Zero | 12 |
| | P + S | 11 | Zero | 11 |

¹Power: 1000 ft-lb torque per engine.

in the WO configuration, where it was virtually the only stall warning available. The premature activation of the artificial stall warning device in the CR, TO, and PA configurations is a shortcoming, because pilots may tend to ignore it.

50. Airframe buffet warning prior to stall is shown in the "buffet to stall" column in table 11. Airframe buffet, when present, increased in intensity as the stall approached and provided excellent cues of the impending stall; however, rapid deceleration to a stall minimized this characteristic. Power effects also minimized buffet and in the WO configuration, after LR paint addition, stall occurred simultaneously with buffet onset. The addition of LR paint to the airplane caused buffet onset and stall at higher airspeeds than the basic airplane. Installation of IR suppressors on the LR-painted aircraft caused not only an additional increase in buffet onset airspeed but changed the character of the buffet. Before the suppressors were installed, buffet onset was distinct. After suppressor installation, there was a marked increase in the airspeed interval over which the airframe was in light buffet. Intervals as large as 8 to 10 KIAS occurred where the airframe was in very light buffet before significant, recognizable buffet occurred. The 8 to 10-KIAS area of light buffet was not included in the "buffet to stall" figures in table 11 because the intensity was low enough that it could be easily mistaken for light turbulence.

Stalls:

Unaccelerated Stalls

51. The power-off stall was characterized in the basic airplane by a gentle but definite nose-down pitch accompanied by a roll if any sideslip was allowed to develop. Rudder application to prevent sideslip while holding the aircraft in stall produced a cyclic pitching motion, with the aircraft alternately stalling and recovering. All controls except ailerons were fully effective throughout the entire stall sequence. Due to the low apparent aileron control power, the ailerons were virtually ineffective in controlling roll, and the large aileron deflections required to produce even minimal roll control induced adverse yaw, which tended to increase the roll tendency. Rudders were the most effective roll and sideslip controls in the stall. Power-on stalls exhibited the same characteristics as power-off stalls, except that airplane response was more pronounced.

52. With the addition of LR paint to the aircraft, the stall generally retained the same characteristics as the basic airplane, both power-on and power-off, except that the pitch rate and attitude changes were decreased by almost half, and the longitudinal control displacement required to achieve stalls was increased by 10 percent. With IR suppressors installed, the stall was characterized by a further diminished nose-down pitch tendency, heavy elevator buffet in addition to airframe buffet, and sink rates near 2500 ft/min, regardless of power. The only configuration/power combination where these cues were degraded was the full-power WO configuration, in which the stall occurred simultaneously with buffet onset at 54 KIAS. Following the stall, the airplane rapidly rolled 135 degrees to

the left and pitched down 70 degrees below the horizon. The artificial warning horn was the only indicator of the impending stall. While this stall is dangerous, it occurs well below the normal airspeed band for approach, landing, and wave-off.

Accelerated Stalls

53. Accelerated stalls were evaluated with power on and power off in the CR, TO, PA, and WO configurations in 30, 45, and 60-degree right and left banked turns. At stall the aircraft tended to roll left. In accelerated stalls to the right a concerted effort was required to hold the aircraft in a stall, with increasing aileron into the turn required as the aircraft approached stall. This inherent left roll initiated recovery for the pilot and minimal pilot compensation was required to complete the recovery (HQRS 3). The left roll tendency increased with the increase of bank angle, flap setting, and power. In left turns the airplane tended to roll further left at stall, but at a reduced roll rate from that experienced in a right turn. The left roll required moderate pilot compensation (HQRS 4) to correct. Full right rudder and aileron were required to arrest the roll and power reduction was required to facilitate recovery. The severity of the airplane reaction at stall increased with bank angle and considerable pilot compensation was required to minimize altitude loss and attitude excursion at stall in a 60-degree left banked turn (HQRS 5). In all accelerated stalls, adequate warning in the form of airframe buffet was present and would prevent inadvertent excursions into accelerated stalls. Also, angles of bank greater than 30 or 45 degrees are seldom encountered during normal maneuvers with this airplane.

Single-Engine Stalls

54. Single-engine stalls with either engine out exhibited essentially the same characteristics as dual-engine stalls, with the exception that stall was always at or below the static airspeed for minimum control (VMC). Rudder deflection was insufficient to prevent sideslip, so all stalls were characterized by a roll coupled with a pitch nose-down. Airplane response was most pronounced in single-engine stalls with the left engine inoperative. These stalls were characterized by a rapid left roll, which increased in rate with the power applied to the operating engine. The significant elevator, rudder, and aileron forces required to maintain single-engine level flight near stall are sufficient to warn the pilot of impending stall.

Stall Recovery:

55. Flaps-up unaccelerated stalls were recovered by relaxing aft control force, lowering the nose of the airplane slightly below the horizon, coordinating rudder and aileron to level the wings, and addition of power to minimize altitude loss. Rapid recovery was hampered by the pronounced secondary stall tendency (reoccurrence of buffet) of the airplane regardless of power, configuration, or external modification. The significant secondary stall tendency of the airplane in all configurations is a shortcoming which should be avoided in future designs.

56. Further investigation of recovery techniques for the full-power WO stall, as discussed in paragraph 52, revealed that altitude loss could be minimized by leaving power on and applying full right rudder and aileron together with rapid forward control at the instant of stall. This recovery technique, however, required exact knowledge of when the stall would occur and precise timing of control inputs. Since the airplane does not adequately buffet prior to stall in the full-power WO configuration, the operational pilot could not be expected to apply the proper controls to prevent post-stall gyrations. An optimum technique to minimize attitude excursions and altitude loss was to simultaneously reduce power to idle and apply forward elevator and full right rudder and aileron to level the wings. Aft stick and power were then coordinated to arrest the rate of descent. The stall characteristics and recovery techniques for stalls with flaps extended should be demonstrated or discussed in detail during U-21 transition training. A discussion of the consequences of stalls with flaps extended should be included in the operator's manual. A proposed change to the text of paragraph 8-11, page 8-1 of the operator's manual discussion of power-on stall recovery is presented below and should be incorporated in the operator's manual.

The roll and pitching tendency present in all U-21A stalls is more pronounced in power-on stalls and increases in severity with flap extension.

NOTE

Power-on stalls with gear and flaps extended occur without the usual warning buffet and may result in the aircraft rolling past a 90-degree left bank angle and rapidly pitching nose-down to near vertical. This results in altitude losses of 1000 feet or more prior to recovery. To minimize attitude excursions and altitude loss, simultaneously reduce power to idle and apply forward elevator and full right rudder and aileron to level the wings. Avoid approaches and go-arounds below 70 KIAS with full flaps and 80 KIAS with approach flaps.

Single-Engine Characteristics

57. The single-engine handling qualities of the U-21A airplane were evaluated for the basic, LR-painted, and LR paint and IR suppressor-configured airplane at the conditions presented in table 3. With the left engine shut down and propeller feathered, the airplane was decelerated at 0.5 knot per second, wings level, until a control limit or stall was reached. The airplane was then banked 5 degrees into the good engine, control deflection adjusted to maintain steady heading, and the deceleration commenced again until a control limit or stall was reached, establishing the static VMC for the airplane. The minimum dynamic VMC was then determined. The minimum dynamic VMC was defined as the lowest possible airspeed at which the pilot could regain and maintain steady straight flight in any configuration following a sudden complete failure of the critical engine. All flight controls were used to effect recovery; however, power was not reduced, trim was not changed,

and the propeller was not feathered. To allow for pilot reaction and recognition time, 2 seconds, a 20-degree bank angle, or 20-degree heading change, whichever came first, was allowed before any corrective action was taken. For additional safety margin, the airspeed selected as the minimum dynamic VMC was that airspeed where 90 percent control deflection, excessive control force, or excessive pilot coordination or skill were required to regain and maintain control. Test results are presented in figure 57, appendix F.

Static Single-Engine Minimum Control Airspeed:

58. Static single-engine VMC in wings-level flight was defined by loss of directional control as a result of achieving full rudder deflection. With a 5-degree bank angle into the operating engine, VMC was defined by airframe stall at 10,000 feet in the CR and TO configurations and full right aileron with associated high aileron forces (40 to 50 pounds) in the WO configuration. Minimum airspeed for trim effectiveness (V_{\min} trim) was 102 KIAS in the CR configuration, 97 KIAS in the TO configuration with right rudder trim at its limit, and 105 KIAS in the WO configuration with both right aileron and right rudder trim at the limit. Because of the inability of the trim system to trim all forces to zero at the static VMC, *sustained flight at the static VMC was uncomfortable, requiring at least 40 pounds of rudder force in all configurations and as much as 40 pounds of aileron force in the WO configuration.* The requirement to hold rudder and aileron forces provides excellent cues of the approach of VMC. Increasing airspeed to the single-engine airspeed for maximum rate of climb (V_{\max} R/C) increased trim effectiveness and single-engine flight was more comfortable.

Dynamic Single-Engine Minimum Control Airspeed:

59. Dynamic VMC was established by the ability of the pilot to regain control of the airplane after a sudden failure of the critical engine and was always higher than the static VMC. Transient control forces at the dynamic VMC were as high as 120 pounds right rudder and 35 pounds right aileron force. With 90 percent rudder and aileron applied after the appropriate delay for normal pilot reactions, the aircraft in all cases continued rolling to as much as 30 degrees of bank angle in the CR and TO configurations and 50 degrees in the WO configuration. Engine failure at airspeeds lower than the dynamic VMC resulted in significantly increased attitude excursions and a corresponding increase in altitude loss, in spite of the full application of prorecovery controls. The dynamic VMC presented in figure 57, appendix F, represent the minimum airspeeds at which the operational pilot could expect a reasonable chance of recovering from a sudden engine failure. For this reason, the data presented in figure 57 and the following WARNING should be included in the operator's manual.

WARNING

Flight below the dynamic minimum control airspeed for the altitude and configurations shown should be limited to operational necessity only, as aircraft control may be lost

following a sudden engine failure below those airspeeds. The static airspeeds for minimum control apply only after the airplane is stabilized in single-engine flight.

60. Addition of the LR paint and IR suppressors to the airplane did not change the VMC for the airplane. Within the scope of this test, the single-engine characteristics of the U-21A airplane are satisfactory.

Takeoff and Landing Characteristics

61. The takeoff and landing characteristics of the basic U-21A airplane and the U-21A with LR paint and IR suppressors installed were evaluated under the conditions presented in table 3. The runways were dry and wind conditions varied from zero during takeoff performance tests to approximately limit crosswind conditions. Takeoff characteristics were evaluated using normal technique (brake release with gradual application of power until achieving takeoff power) and maximum performance techniques (brake release after takeoff power had been achieved and stabilized). The airplane was initially lined up 5 degrees right of the center line to counteract torque effects during maximum performance takeoffs. The brakes were capable of holding the airplane at takeoff power; however, a brake pedal force of 150 to 200 pounds was required to prevent creeping. Simultaneous brake release was accomplished easily and torque effects aligned the airplane with the center line, permitting a smooth takeoff roll. Representative time histories of takeoffs are presented in figures 58 through 60, appendix F.

62. Normal takeoff with a forward cg was easily accomplished (HQRS 3). Nose-up trim was preset before takeoff and as the airplane accelerated, an aft control force of 10 pounds was required to lift the nose wheel off the runway at 104 KIAS. Holding the nose wheel off, aft force was gradually relaxed to approximately 2 pounds as the main landing gear lifted off the runway at 97 KIAS. The landing gear was immediately retracted upon lift-off and aft control wheel force was again required to prevent the airplane from accelerating past the 127-KIAS gear retraction limit speed because of the slow (6 seconds) gear retraction travel time. The low retraction limit airspeed is a shortcoming, because it can easily be inadvertently exceeded. Once the landing gear had been retracted, a forward control force of 20 to 30 pounds followed by a nose-down trim change was required during transition to a trimmed 140-KIAS climb condition.

63. During takeoffs using the maximum performance technique the main landing gear lift-off speed of 97 KIAS was maintained during climb-out. This required an initial aft control force (up to 7 pounds) followed by a push force of up to 30 pounds to counter the pitch-up tendency with gear retraction. A nose-up pitch attitude of 20 degrees was required to maintain airspeed as the landing gear was retracted. The large trim change with gear retraction after takeoff is a shortcoming which should be corrected in future designs.

64. The forward field of view during climb-out using the maximum performance technique was severely restricted by the instrument panel glare shield, which

blocked out everything below 30 degrees above the horizon. The restriction to forward field of view was extremely annoying and posed a potential safety problem during climb-out in that the pilot could not see to avoid obstacles. The poor forward field of view of the U-21A during climb-out is a shortcoming which should be corrected in future designs.

65. The low (0.2 to 0.3 Hz) undamped natural frequency of the short period, the light elevator control forces and the large trim change with gear retraction significantly increased pilot work load to maintain constant airspeed during maximum performance takeoffs as the target lift-off airspeed decreased. Pilot work load was extensive at 85 KIAS (HQRS 6). An indication of this pilot work load is shown by the elevator control force in figures 58 through 60, appendix F. Large control inputs (as much as ± 8 percent) at a frequency of one per second with smaller inputs up to three per second, were necessary to obtain desired airplane response. Pilot work load at 100 KIAS, however, was significantly improved, as shown by the elevator control force in figure 60, appendix F. Control inputs at 100 KIAS were smaller (less than ± 1 percent) with the same frequency. Because of the improved handling qualities, decrease in work load, improved field of view, and dynamic VMC considerations discussed in paragraph 59, the lift-off airspeed should be increased to 100 KIAS for normal operations with acceleration to 140 KIAS for climb-out, and performance charts developed for this technique.

66. Takeoffs with an aft cg were more difficult both in the basic and modified U-21A airplane. The takeoff sequence was essentially the same except for the initial trim setting. Moderate pilot compensation was required to prevent unintentional overrotation (HQRS 4). Precise airspeed control during the takeoff sequence was also more difficult. Field of view was essentially the same as described for the forward cg takeoffs.

67. Landing characteristics were evaluated using normal landing techniques at the conditions shown in table 3. Power approaches to landing were performed primarily because of the high test gross weights. Downwind airspeed was 140 KIAS with transition to 120 KIAS by the 180-degree point, 110 KIAS on base, and 100 KIAS on final approach. Touchdown airspeeds were approximately 80 KIAS with full flaps, 90 KIAS with approach flaps, and 100 KIAS with no flaps. At a forward cg, aircraft and airspeed control were easy in all wind conditions up to limit crosswinds. At an aft cg, precise airspeed control and tracking tasks such as glide slope maintenance required minimal pilot compensation to achieve desired results (HQRS 3). In the presence of light turbulence, these tasks required moderate pilot compensation (HQRS 4). During the round-out phase of the landing sequence the overly sensitive pitch response in the PA configuration due to the light longitudinal stick forces caused a ballooning tendency prior to touchdown (HQRS 4). Airspeed and attitude control during landing round-out were improved at cg locations near the forward limit. In both the forward and aft cg loadings, the stall warning horn intermittently activated (well above stall airspeed) during the round-out for landing. The premature activation of the stall warning horn prior to touchdown during the landing round-out is a shortcoming which should be corrected in future designs.

68. The addition of LR paint and IR suppressors to the airplane had no effect on the takeoff and landing handling qualities of the U-21A.

Trimmability

69. The capability to trim the aircraft to a given airspeed and zero control force was evaluated throughout all flight tests. For all configurations tested, longitudinal and directional control forces could be trimmed to zero (dual-engine) throughout the flight envelope. Longitudinal and directional trim were compatible in sensitivity. The pilot could select large trim changes with very little trim control movement in both the longitudinal and directional axes. Lateral trim control, however, was almost totally ineffective. At 140 KCAS the aileron trim could be displaced full travel (± 30 units left and right of zero trim) with less than 2 pounds total lateral force change at the stick in straight and level flight. The ineffective lateral trim system of the U-21A is a shortcoming which should be corrected in future designs.

SUBSYSTEM TESTS AND MODIFICATION EVALUATION

Engine Performance

70. Engine performance with and without the IR suppressors installed was evaluated by UACL in an engine test cell; during static thrust runs on the Air Force thrust stand at Edwards Air Force Base, California, at the conditions presented in table 4; and during level flight performance tests. Results were compared in the form of referred engine parameters and representative curves are presented in figures 61 through 64, appendix F.

71. In a letter report dated 17 July 1975, UACL stated that as a result of the engine test cell runs, the IR suppressors had the following effect on the T74-CP-700 engine at sea-level, standard-day conditions:

a. With the IR suppressors installed, at 36,000 rpm referred gas producer speed, there was a reduction of 12 referred shp (approximately 2.5 percent) available.

b. At the takeoff rating of 550 referred shp, with the IR suppressors installed, the engine ran 210 rpm referred gas producer speed faster and 6°C referred interstage turbine temperature hotter.

72. Static ground runs and level flight performance test results are presented in table 12. Static ground run data confirmed the UACL engine test cell data and in-flight data confirmed the reduction in available shp. This loss of power available due to the IR suppressors represents approximately 12 shp. All other installation losses are included in reference 11, appendix A. All performance calculations for flights with IR suppressors installed were based on an additional 12-shp loss per

engine. The 12-shp loss was treated as an additional accessory loss which was input to the UACL engine deck. Within the scope of this test, engine performance with the IR suppressors installed is satisfactory.

Table 12. IR Suppressor Effects on Engine Performance.

| Test | Engine | Propeller Speed (rpm) | Reduction in Available Referred Shaft Horsepower ¹ | Increase in Referred Gas Producer Speed ² (rpm) |
|-------------------|--------|-----------------------|---|--|
| Static ground run | No. 1 | 2200 | 16 | 282 |
| | | 2000 | 14 | 263 |
| | | 1900 | 15 | 282 |
| | No. 2 | 2200 | 13 | 244 |
| | | 2000 | 12 | 225 |
| | | 1900 | 12 | 225 |
| Level flight | No. 1 | 1900 | 19 | 263 |
| | No. 2 | 1900 | 19 | 263 |

¹Read at $36,000 N_1/\sqrt{\theta}$ (constant referred gas producer speed).
100 percent $N_1 = 37,540$ rpm.

²Read at $510 \text{ shp}/\delta\sqrt{\theta}$ (constant referred shaft horsepower).

Infrared Suppressors

Vibration:

73. Triaxial accelerometers were mounted in the vertical plane on the tips of the IR suppressors; but a malfunction of the system prevented any data from being obtained. Time did not allow correction of the problem before the termination of the program. Tests were conducted at the conditions presented in table 4.

74. Throughout all flight regimes, the left engine inboard exhaust suppressor tip vibrated more visibly than any of the other three suppressors. An amplitude of approximately 1/8 inch was estimated at 1900 propeller rpm with power applied. The frequency of such a vibration, corresponding to the three blade propeller passage, was estimated at approximately 95 Hz. An amplitude of 1/8 inch at 95 Hz corresponds to 57g. Because vibration amplitudes observed in flight apparently

exceeded those reported during ground structural qualification tests at BAC, further testing should be accomplished to determine if this vibration is detrimental to the structural life of the suppressors.

Reliability:

75. The external foamed aluminum coating deteriorated during the conduct of the tests. Two types of deterioration were noted:

a. Internal failure of the honeycomb-type structure of the foamed aluminum, with erosion occurring under normal air loads, as shown in photos 1 through 3.



Photo 1. Surface Erosion.



Photo 2. Surface Erosion.



Photo 3. Surface Erosion.

b. Separation of the foamed aluminum in chunks from the suppressor surface because of bonding fatigue between the aluminum sections and the suppressors, as shown in photos 4 through 6. A possible cause for both types of coating failure could be the vibrations of the suppressors discussed in paragraph 74. Also, the foamed aluminum coating was extremely vulnerable to any rough handling and crushed very easily, as shown in photo 7. Further reliability testing should be accomplished to determine the ability of the suppressor coating to withstand normal handling and extended use.



Photo 4. Bonding Separation.

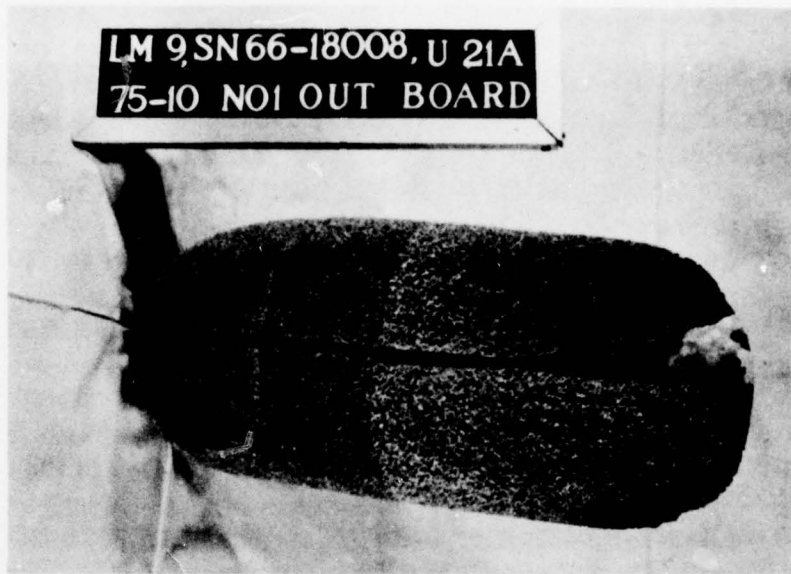

Photo 5. Bonding Separation.

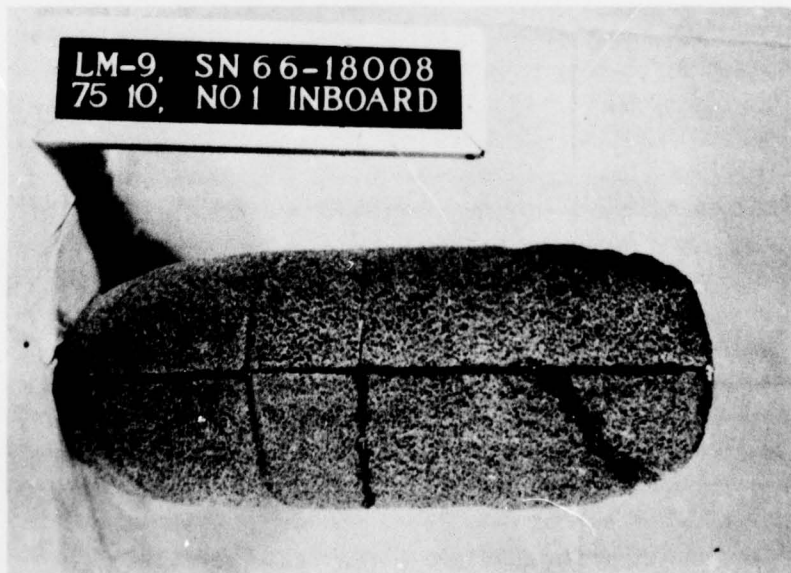

Photo 6. Bonding Separation.

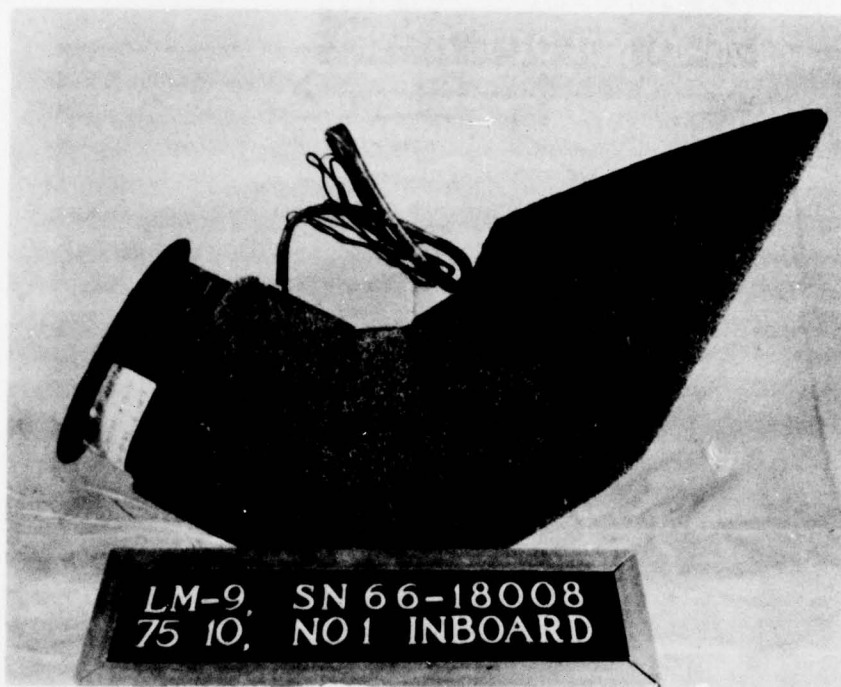
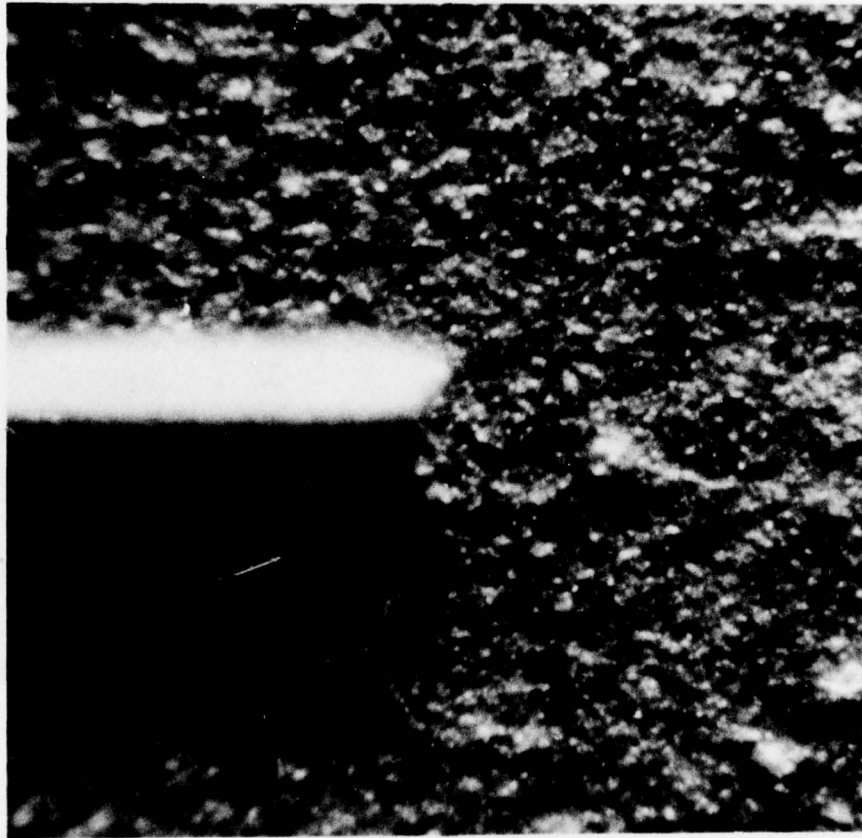

Photo 7. Surface Crushing.

Low Reflective Paint

76. A qualitative evaluation of other LR-painted aircraft revealed a marked variation in paint surface roughness. A special technique is required to apply the paint evenly without an unnecessary roughness resulting. The painters who painted the test aircraft had received recent instruction in the proper method of painting aircraft with LR paint. Examples of typical variations in paint roughness are shown in closeup photos 8 through 10, taken of an OH-58, AH-1G, and the test airplane, all painted by different painters at different times. The U-21A was the most uniform and least rough of the three.



**Photo 8. OH-58A LR Paint Closeup With
a Mechanical Pencil Lead for Contrast.**



**Photo 9. AH-1G LR Paint Closeup
With a Dime for Comparison.**

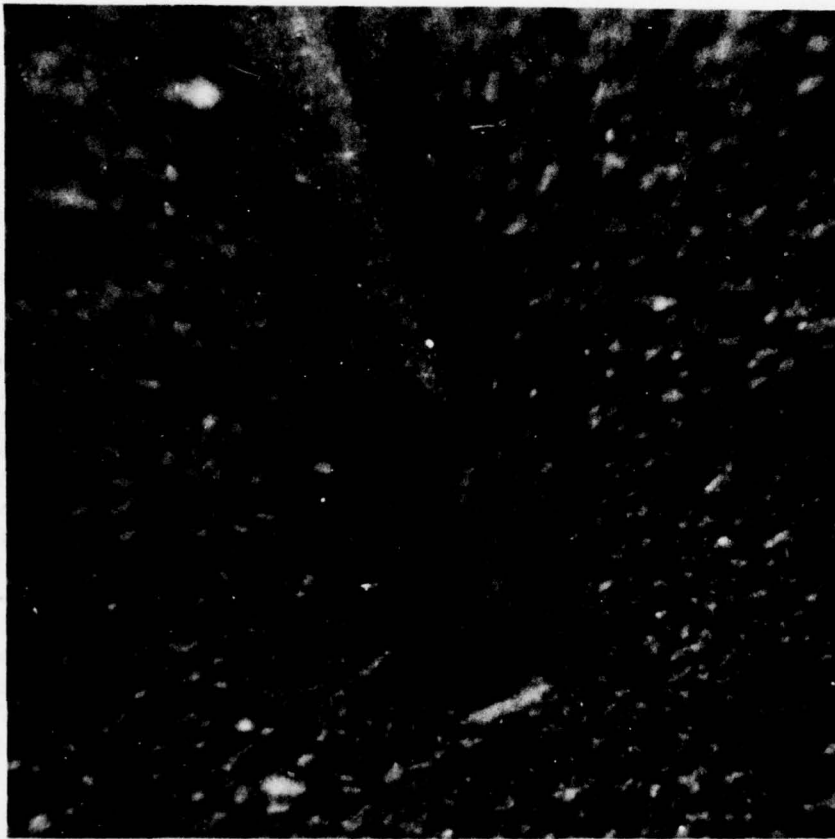

**Photo 10. U-21 A LR Paint Closeup With
a Mechanical Pencil Lead for Contrast.**

77. Because of the surface roughness variations, the data in this report may not be representative of other LR-painted U-21A airplanes. The highly variable nature of the paint application requires that stringent control measures be implemented to ensure that operational airplanes receive an LR paint application with a quality equal to that of the test aircraft, in order to ensure that the handbook data obtained during these tests will be representative of the operational airplanes. An increase in the surface roughness could cause increased degradation in performance beyond that measured during the tests.

Pitot-Static Source Position Error

78. The pitot-static source position error was determined at the conditions presented in table 4, using space positioning radar and the pace method. Airspeed calibrations were accomplished before flight tests of the basic U-21A began and after the LR paint was applied. The test results are presented in figures 65 through 70, appendix F. A summary of paint effects on the altimeter position error is presented in figure C.

79. The airspeed and altimeter calibrations for the basic U-21A showed slightly higher airspeed (2 to 3 knots) and higher (10 to 20 feet) altimeter position errors than presented in the operator's manual. Application of LR paint reduced the aircraft pitot-static position error, as shown in figure C. The low-air-speed position errors in the 100 to 208-KIAS range after application of LR paint will enhance accurate instrument and visual flight because the pilot can fly indicated airspeed essentially as calibrated airspeed. The pitot-static position error change after painting decreased the altimeter correction to be added by 10 to 45 feet in CR and by 20 to 35 feet in PA configurations and the airspeed correction by 2 to 3 KIAS in all configurations. The small altimeter position error above 130 KIAS in CR and near 120 KIAS in PA configuration will allow the pilot to fly indicated altitude as calibrated altitude and will enhance the precision and safety of instrument flight. The pitot-static position error data presented in figures 65 through 70, appendix F, should be included in the operator's manual for both the basic and LR-painted airplanes. No change of position error occurred with the addition of the IR suppressors to the airplane.

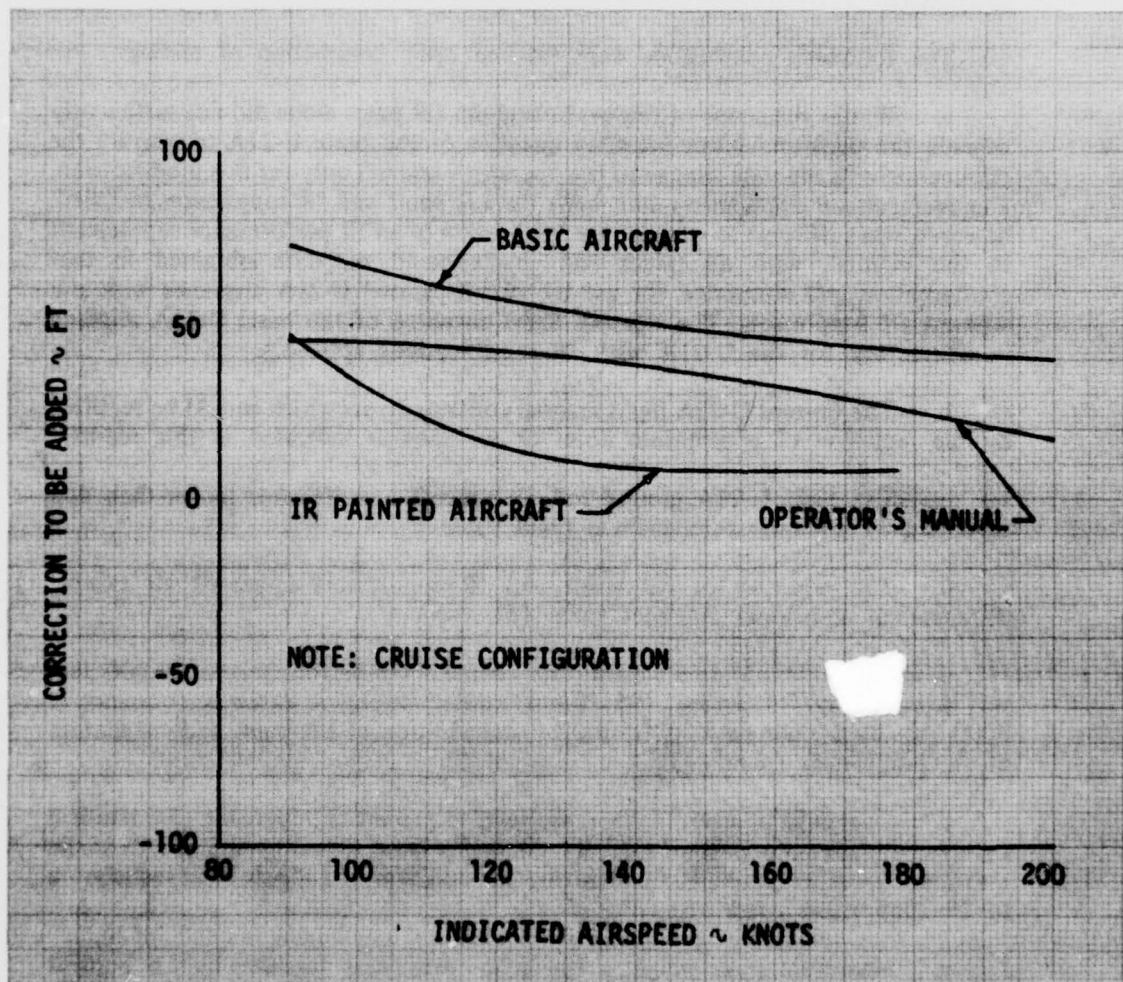

Figure C. Altimeter Position Error Variation at 10,000 Feet With External Modification.

CONCLUSIONS

GENERAL

80. The following conclusions were reached upon completion of testing:

a. Within the scope of this evaluation the LR paint alone did not sufficiently degrade the performance or handling qualities of the basic U-21A to warrant the publication of a separate change to the operator's manual only for this modification. The performance degradation with both the LR paint and IR suppressors installed, however, was sufficient to warrant the publication of an IR performance supplement to the manual, with all tables and charts based on data obtained in that configuration and annotated for use by all LR-painted U-21A airplanes with and without IR suppressors. The existing flight envelope of the basic U-21A airplane is satisfactory for the U-21A with IR modifications applied.

b. The current U-21A flight manual contains errors which should be rectified by the inclusion of appropriate notes or revisions as indicated in this report.

c. The basic U-21A ground roll for takeoff was 400 feet longer than that presented in the operator's manual (para 9).

d. The addition of LR paint and IR suppressors increased all takeoff distances an additional 100 feet (para 10).

e. At maximum gross weight, dual-engine climb performance at 10,000 feet was degraded by 7.6 percent (95 ft/min) and single-engine climb performance at 5000 feet by 27 percent (70 ft/min) by the addition of LR paint and installation of IR suppressors (para 14).

f. Dual-engine level flight range was degraded 5.9 percent (54 nautical miles), endurance 3.4 percent (.22 hours), and V_H decreased by 8.5 KTAS at the maximum gross weight at 10,000 feet by the addition of LR paint and installation of IR suppressors (para 16).

g. Maximum gross weight single-engine range was degraded by 2.6 percent and endurance by 6 percent by the addition of LR paint and installation of IR suppressors (para 18).

h. Stall airspeeds increased approximately 3 KIAS with the addition of LR paint and 3 KIAS more (total of 6 KIAS) with the installation of the IR suppressors (para 20).

i. The static longitudinal stability control force gradients about all trim airspeeds increased slightly with the addition of LR paint and installation of IR suppressors (para 25).

j. The static lateral-directional stability control force gradients about all trim airspeeds increased slightly with the addition of LR paint and installation of IR suppressors (para 28).

k. The phugoid damping increased and the period decreased slightly with the addition of LR paint and installation of IR suppressors (para 35).

l. The spiral mode was slightly convergent after LR paint and IR suppressors had been installed (para 38).

m. The roll rate response following a step aileron input became more oscillatory after LR paint addition (para 45).

n. The addition of LR paint and IR suppressors decreased the stall warning margin slightly and changed the character of the buffet (para 50).

o. The pitch rate and attitude changes at stall were decreased considerably by the addition of LR paint and IR suppressors (para 52).

p. The addition of IR suppressors to the engines decreased maximum power available by 2.5 percent (para 71).

q. The in-flight vibration amplitudes of the IR suppressors apparently exceeded those reported during ground structural qualification tests at BAC (para 74).

r. Erosion, bonding failure, and crushing of the IR suppressor surface coating makes the reliability of the suppressors questionable (para 75).

s. The pitot-static source position error was reduced with the application of LR paint to the airplane (para 79).

t. Ten handling qualities shortcomings which were not attributable to the LR paint or IR suppressors were identified during the evaluation. Shortcomings were defined in accordance with AR 70-10.

SHORTCOMINGS

81. The following shortcomings were identified:

a. The lightly damped, easily excited phugoid mode of motion (para 35).

b. The lightly damped, easily excited, persistent Dutch roll in the presence of turbulence (para 37).

c. The low longitudinal stick force per g in the PA configuration (para 41).

- d. The premature activation of the artificial stall warning horn in the CR and PA configurations (para 49).
- e. The significant secondary stall tendency of the airplane in all configurations (para 55).
- f. The low landing gear retraction limit airspeed (para 62).
- g. The large trim change with retraction of the landing gear after takeoff (para 63).
- h. The poor field of view of the U-21A during climb-out (para 64).
- i. The premature activation of the artificial stall warning horn prior to touchdown during landing round-out (para 67).
- j. The ineffective lateral trim system of the airplane (para 69).

RECOMMENDATIONS

82. The U-21A airplane with LR paint applied should be released for operational use within the limits defined by the current operator's manual, and the recommendations of this report. The release of the IR suppressors for flight should be restricted to operational necessity until the suppressor coating reliability has been improved, the vibration characteristics on all suppressors have been quantitatively evaluated in flight throughout the entire propeller operation speed range, and the suppressors structurally qualified.

83. Correct the shortcomings listed in paragraph 81 in future designs.

84. Include the following WARNING in the operator's manual in conjunction with the VMC chart in figure 57, appendix F (para 59).

WARNING

Flight below the dynamic minimum control airspeeds for the altitude and configurations shown should be limited to operational necessity only, as aircraft control may be lost following a sudden engine failure below those airspeeds. The static airspeeds for minimum control apply only after the airplane is stabilized in single-engine flight.

85. Include the following CAUTIONS in the operator's manual:

a. From paragraph 28:

CAUTION

Approaches with a crosswind component in excess of 15 knots should be made with flaps up and an approach speed of 120 KIAS maintained until just prior to touchdown.

b. From paragraph 41:

CAUTION

Avoid large or abrupt elevator control movements when operating at an aft cg with the gear and flaps extended, as maneuver load factor limits for flaps-extended flight may be exceeded.

- c. From paragraph 42:

CAUTION

Load factors of less than 0.0g may cause dual-engine flameout due to fuel starvation.

- 86. Include the following NOTES in the operator's manual:

- a. From paragraph 9:

NOTE

Add 400 feet to all takeoff distances computed from the takeoff performance charts for the basic U-21A.

- b. From paragraph 10:

NOTE

For aircraft painted with low reflectivity paint, with and without IR suppressors installed, an additional 100 feet should be added to all distances computed from the corrected takeoff performance chart.

- c. From paragraph 20:

NOTE

For airplanes painted with low reflectivity paint, add 3 KIAS to the stall airspeed determined from the stall airspeed chart. For airplanes with both LR paint and IR suppressors installed, add 6 KIAS to the stall airspeed determined from the stall airspeed chart.

- 87. Incorporate the following changes to the operator's manual (para 11).

- a. Change the last two sentences in the Normal Operation section entitled "Minimum Run Landing" to read:

For maximum reverse propeller thrust, place the engine condition levers to HI IDLE as part of the final landing check. Return to Beta range when reverse is no longer needed and place the condition levers to LO IDLE.

- b. Add the following check to the landing checklist (para 11):
 - 3. Condition levers - HI IDLE (for minimum run landing only).
- c. Amend the after landing checklist to read (para 11):
 - 1. Condition levers - LO IDLE.
- d. Publish the dual- and single-engine climb data for the LR-painted U-21A with IR suppressors installed in the IR performance supplement to the operator's manual (para 14).
- e. Correct the true airspeed scale on figure 14-26 of the performance charts section (para 17).
- f. Publish the dual- and single-engine level flight data for the LR-painted U-21A with IR suppressors installed in the IR performance supplement to the operator's manual (para 17).
- g. Include the stall airspeed data in figure 12, appendix F, with the NOTE referenced in paragraph 86, as shown in paragraph 20.
- h. Change paragraph 8-11, page 8-1, to read (para 56):

The roll and pitching tendency present in all U-21A stalls is more pronounced in power-on stalls and increases in severity with flap extension.

NOTE

Power-on stalls with gear and flaps extended occur without the usual warning buffet and may result in the aircraft rolling past a 90-degree left bank angle and rapidly pitching nose-down to near vertical. This results in altitude losses of 1000 feet or more prior to recovery. To minimize attitude excursions and altitude loss, simultaneously reduce power to idle and apply forward elevator and full right rudder and aileron to level the wings. Avoid power approaches and go-arounds below 70 KIAS with full flaps and 80 KIAS with approach flaps.

- i. Include the data presented in figure 57, appendix F, with the WARNING referenced in paragraph 84, as shown in paragraph 59.
- j. Increase the recommended lift-off airspeed for normal takeoffs to 100 KIAS and develop performance charts for this technique (para 65).

88. Accomplish the following additional testing:

a. Develop accurate takeoff performance charts, to include distances for minimum run takeoffs with one-half flaps (para 9).

b. Determine if the vibration of the IR suppressors is detrimental to the structural life of the suppressors (para 74).

c. Determine the ability of the suppressor coating to withstand normal handling and extended use (para 75).

89. Establish stringent control measures to ensure uniform standards of paint application, so that data obtained during these tests will be applicable to all operational LR-painted U-21A's (para 77).

APPENDIX A. REFERENCES

1. Letter, AVSCOM, AMSAV-EQI, 25 February 1975, subject: Airworthiness Qualification Tests on the U-21/RU-21 (T74-CP-700 Engine Series) Hot Metal Suppressors.
2. Technical Manual, TM 55-1510-209-10/01, *Operator's Manual, Army Model U-21A, RU-21A, and RU-21D Aircraft*, with Change 4, 28 June 1974.
3. Letter, AVSCOM, AMSAV-EQI, 6 May 1975, subject: Safety of Flight Release for U-21 with IR Suppressor System Installation.
4. Flight Test Manual, Naval Air Test Center, FTM No. 104, *Fixed Wing Performance*, 28 July 1972.
5. Flight Test Manual, Naval Air Test Center, FTM No. 103, *Fixed Wing Stability and Control*, 1 August 1969.
6. Handbook, Air Force Test Pilot School, FTC-TIH-70-1001, *Performance*, September 1970.
7. Handbook, Air Force Test Pilot School, FTC-TIH-68-1002, *Stability and Control*, September 1968.
8. Military Specification, MIL-M-63029A(TM), *Requirements for Operators and Crewmembers Manual and Checklist for Aircraft*, 15 April 1974.
9. Technical Note, USAAEFA, TN No. 75-84, *Determination of Airspeed Position Error on the F-51D Using Radar Tracking and the Timed Ground Speed Course*, 7 May 1975.
10. Federal Aviation Administration, Federal Air Regulation FAR Part 23, *Airworthiness Standards: Normal, Utility, and Aerobatic Category Airplanes*, 13 March 1971.
11. UACL Computer Performance Program 1518B, "PT6 General Installed Engine Performance," December 1972.

APPENDIX B. DESCRIPTION

GENERAL

1. The U-21A test aircraft was a production U-21A. A three-view drawing of the basic U-21A is shown in figure 1. Two views of the basic test aircraft are shown in photos 1 and 2. The same two views of the test aircraft with LR paint and IR suppressors installed are shown in photos 3 and 4.

AIRCRAFT DIMENSIONS

General

| | |
|----------------------------|-------------------|
| Span | 45 ft, 10-1/2 in. |
| Length (overall) | 35 ft, 6 in. |
| Height | 14 ft, 2-9/16 in. |
| Propeller ground clearance | 12 in. |
| Design gross weight | 9650 lb |

Wings

| | |
|--|------------------------|
| Type | Low |
| Airfoil section (theoretical at center line of fuselage) | 23014.10 modified NACA |
| At root of outer panel | 23016.22 modified NACA |
| Theoretical tip | 23012 modified NACA |
| Chord at root (theoretical at center line of fuselage) | 84.611 in. |
| Chord near tip (theoretical tip) | 42 in. |
| Mean aerodynamic chord | 77.86 in. |
| Incidence at root | 4.8 deg |
| Incidence at theoretical tip | Zero deg |
| Dihedral | 7 deg |
| Sweepback (outer panel at 25 percent chord) | Zero deg |
| Aspect ratio | 7.51 |

Stabilizer

| | |
|---|----------------|
| Span | 17 ft, 2.7 in. |
| Maximum chord (center line at fuselage) | 66.20 in. |
| Incidence | 1 deg |
| Dihedral | 7 deg |
| Sweepback of leading edge | 10 deg, 13 min |

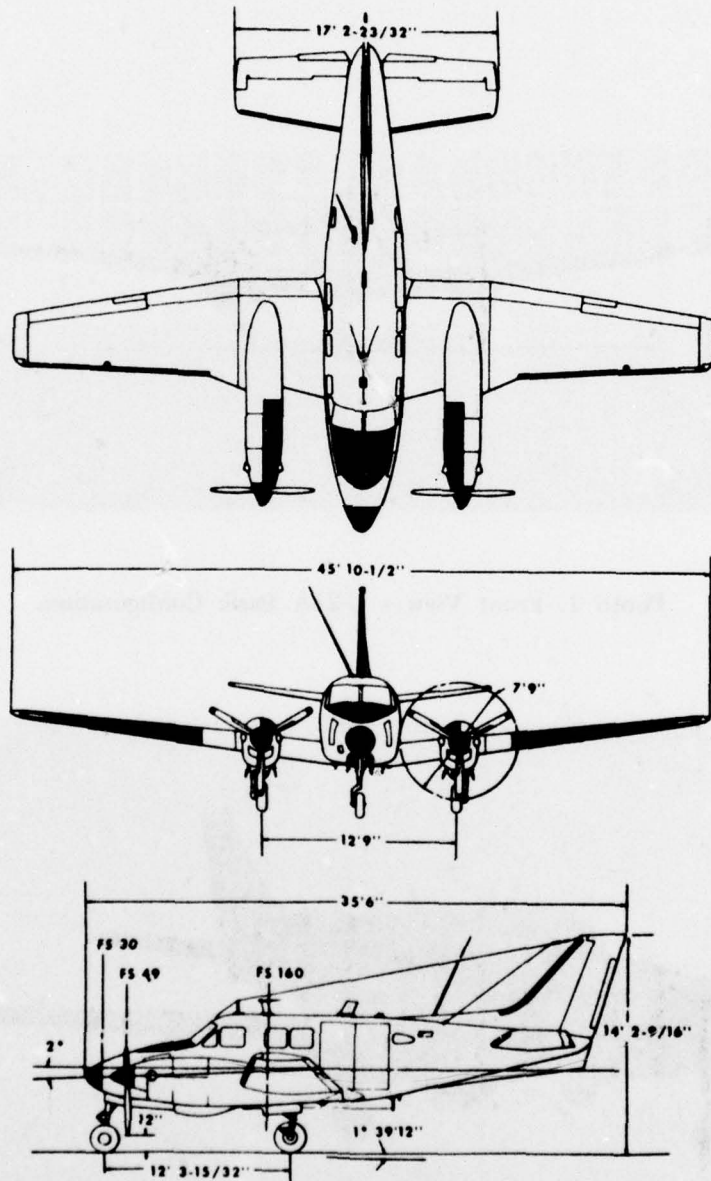

Figure 1. Three Views - Basic U-21A Airplane.

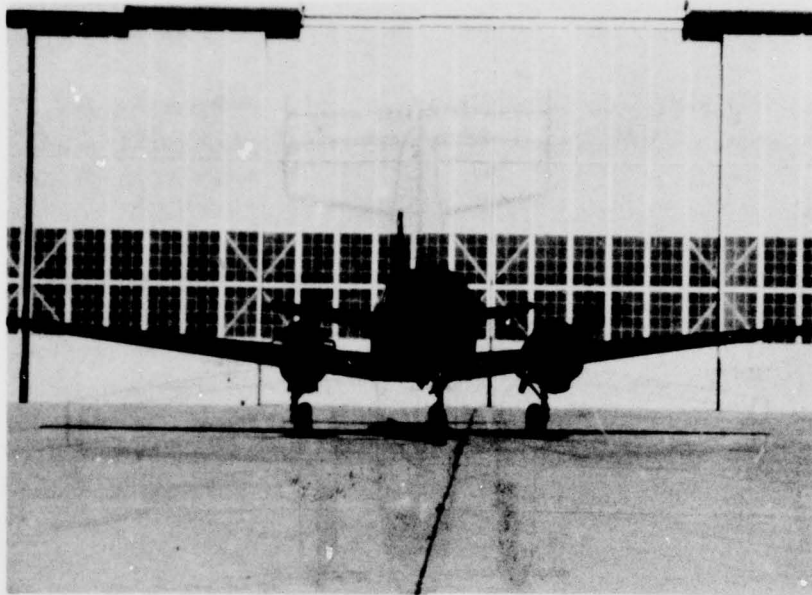

Photo 1. Front View - U-21A Basic Configuration.



Photo 2. Left Front Quarter View - U-21A Basic Configuration.

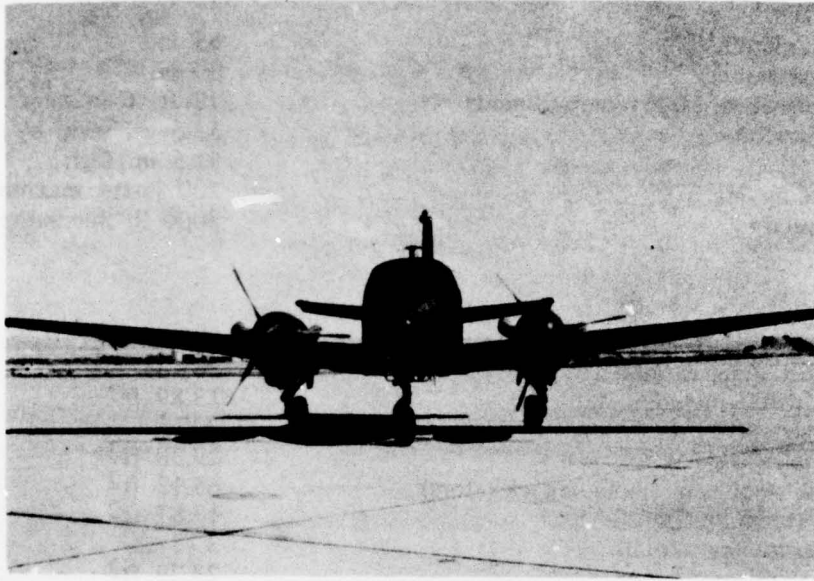

Photo 3. Front View - U-21A With LR Paint and IR Suppressors.



Photo 4. Left Front Quarter View - U-21A With LR Paint and IR Suppressors.

Fuselage

| | |
|--------------------------------------|-----------------------------------|
| Width (maximum) | 55 in. |
| Height (maximum) | 57 in. |
| Length (passenger-cargo compartment) | 12 ft, 6 in. |
| Door dimensions | 53.5 in. wide by 51.5 in. high |
| Floor loading (cargo) | 200 lb/ft ² maximum |
| Cargo capacity | 3000 lb maximum |

Areas

| | |
|--|------------------------|
| Wings (total) | 279.74 ft ² |
| Wings (with flaps extended) | 265.85 ft ² |
| Ailerons (total) including tab | 13.89 ft ² |
| Aileron tab | 2 ft ² |
| Flaps (total) | 29.30 ft ² |
| Horizontal stabilizers (including elevators) | 65.12 ft ² |
| Elevators (including tabs) | 17.87 ft ² |
| Elevator trim tabs (total) | 3.13 ft ² |
| Vertical stabilizer | 23.29 ft ² |
| Rudder (including tab) | 14 ft ² |
| Rudder tab | 2.05 ft ² |

FLIGHT CONTROL SYSTEM

Primary Flight Controls

2. The U-21A airplane is provided with a fully reversible flight control system consisting of conventional dual controls for the pilot and copilot. Control wheels, interconnected by a T-column, and adjustable rudder pedals interconnected by a linkage below the floor, are linked to the control surfaces through a closed system of cables, bell cranks, and push-pull tubes. A set of elevator downsprings has been incorporated to improve longitudinal control force static stability in flight. A set of rudder surface return springs has been incorporated to assist in positive rudder centering and to provide additional force feel in the directional control system, particularly at high rudder deflection angles.

Secondary Flight Controls

3. Trim control for the rudder, aileron, and elevator is accomplished through a manually actuated cable drum system for each set of control surfaces. Trim tabs are located on each of the flight control surfaces and incorporate antiservo action on the ailerons and elevator. A resultant increase in effective control surface deflection and control force is realized by this action. The rudder trim is adjustable left and right to maintain a desired position or displacement for yaw trim.

4. The all-metal, single-slotted flaps are electrically operated and consist of two sections on each wing. These sections extend from the inboard end of each aileron to the wing and fuselage juncture. During operation, the flaps are actuated as a single unit by separate but synchronized jackscrews. The jackscrews are driven through flexible shafting by a single reversible electric motor. Flap displacement is displayed in percent of travel by a position indicator on the center pilot control pedestal. Normal flap positions are UP (zero percent), APPROACH (35 percent-15 degrees), and FULL DOWN (100 percent-43 degrees). Flaps may be modulated between APPROACH and FULL DOWN.

Limit Control Travel

5. The maximum limits of control travel are presented in table 1.

Table 1. Control Surface Travel.

| Control Surface | Travel (deg) | | Tolerance (deg) |
|---|--------------|-------|-----------------|
| | Up | Down | Plus |
| Ailerons | 20 | 20 | 1-1/2 |
| Aileron trim tab (left-hand only) | 7-1/2 | 7-1/2 | 1-1/2 |
| Aileron antiservo tabs (right-hand antiservo) | 14 | 8 | 2 |
| Elevators | 25 | 15 | 1 |
| Elevator trim tab | 10 | 21 | 1-1/2 |
| Elevator antiservo tabs | 12 | 8 | 1-1/2 |
| Flaps | -- | 43 | 1 |
| Rudder | Right | Left | 1 |
| | 24 | 26 | |
| Rudder trim tab | 30 | 30 | 1-1/2 |

PROPULSION SYSTEM

6. The T74-CP-700 (PT6A-20) engine, manufactured by United Aircraft of Canada, Ltd, has a three-stage axial, single-stage centrifugal compressor driven by a single-stage reaction turbine. The power turbine, counterrotating with the compressor turbine, drives the output shafts with speed reduction being provided by a two-stage planetary gearing. The engines produce 550 shp sea level standard-day each in the standard configuration with the standard exhaust stubs. Maximum continuous speed of the compressor is 38,100 rpm (101.5 percent N₁). Prior to gear reduction, the maximum power turbine speed is 36,850 rpm which, when reduced, corresponds to 2200 propeller rpm at 1315 ft-lb of torque. The two engines installed on the test aircraft were production engines (left engine SN PC-E-30009 and right engine SN PC-E-21153). Both power plants are 3000-hour time-before-overhaul engines and each had 112 hours flight time at the beginning of the flight tests.

7. Exhaust gases from the engine are passed from the turbine into the exhaust ducts and exit the engine through exhaust ports located on each side of the duct. On the basic airplane engine, a standard divergent heat resistant steel exhaust stub (photo 5) is attached to each exhaust port (photo 6). With the standard exhaust stub the exhaust gases from the exhaust ports are turned approximately 45 degrees and directed outboard and aft into the air stream. The Hughes IR suppressor, as shown in photo 7 and the drawing in figure 2, was designed to replace the standard exhaust stub. The Hughes IR suppressor consists of an all-aluminum exhaust tube bolted to a 321/347 annealed steel mounting stack. The aluminum tube is covered with a 1/2-inch-thick coat of foamed aluminum bonded to the surface of the tube. The suppressor is mounted to the exhaust port in the same manner as the standard exhaust stub. With the IR suppressor installed, exhaust gases from the exhaust ports are turned 90 degrees aft and elevated 18 degrees before discharge into the air stream, as shown in figure 3 and photos 8, 9, and 10.

8. Engine power ratings for the T74-CP-700 engine series as installed in the U-21A are shown in table 2.

Table 2. Engine Power Ratings.

| Power Setting | Interturbine Temperature (°C) | Torque (ft-lb) | Gas Producer Speed (%) | Time Limit (min) |
|---------------------------|-------------------------------|----------------|------------------------|------------------|
| Takeoff power | 750 | 1315 | 101.5 | 5 |
| Normal rated climb power | 725 | -- | 101.5 | Continuous |
| Normal rated level flight | 705 | -- | 101.5 | Continuous |



**Photo 5. Standard U-21A Engine Exhaust Stubs.
(with special thermocouples installed)**

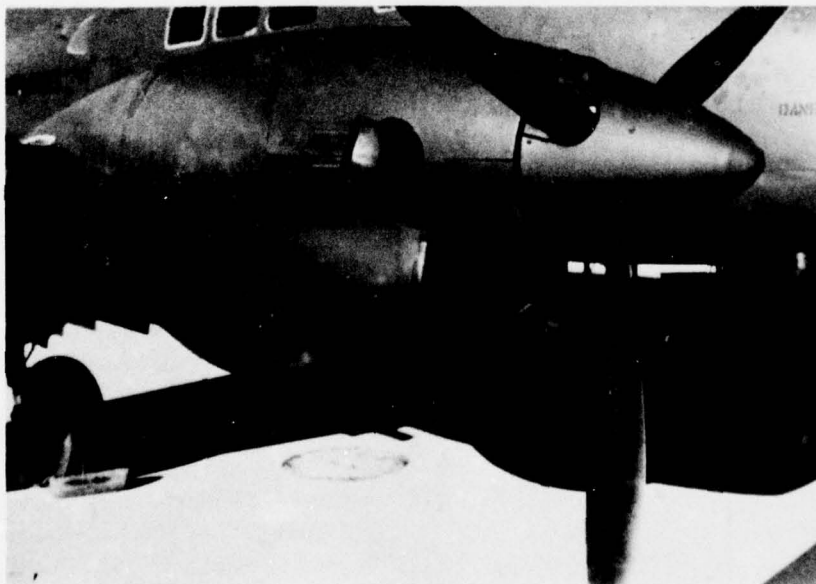

Photo 6. Standard U-21A Engine Exhaust Stubs Installed on Aircraft.

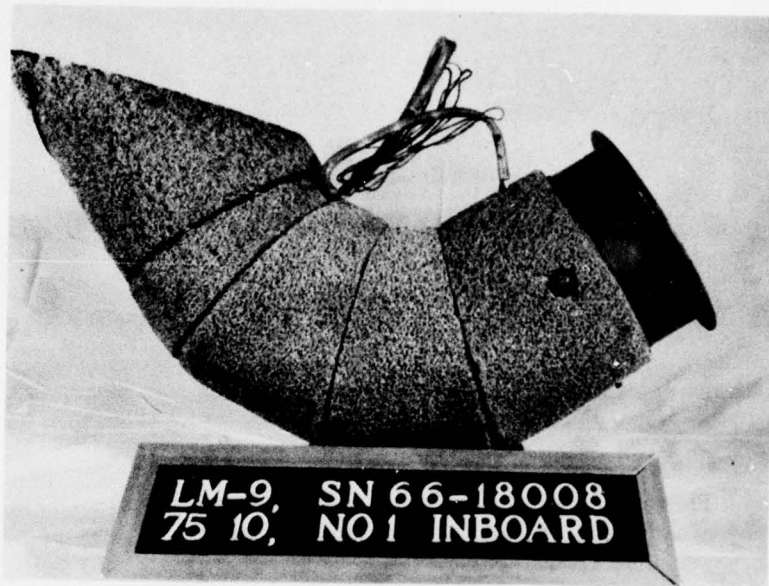

Photo 7. IR Suppressor.

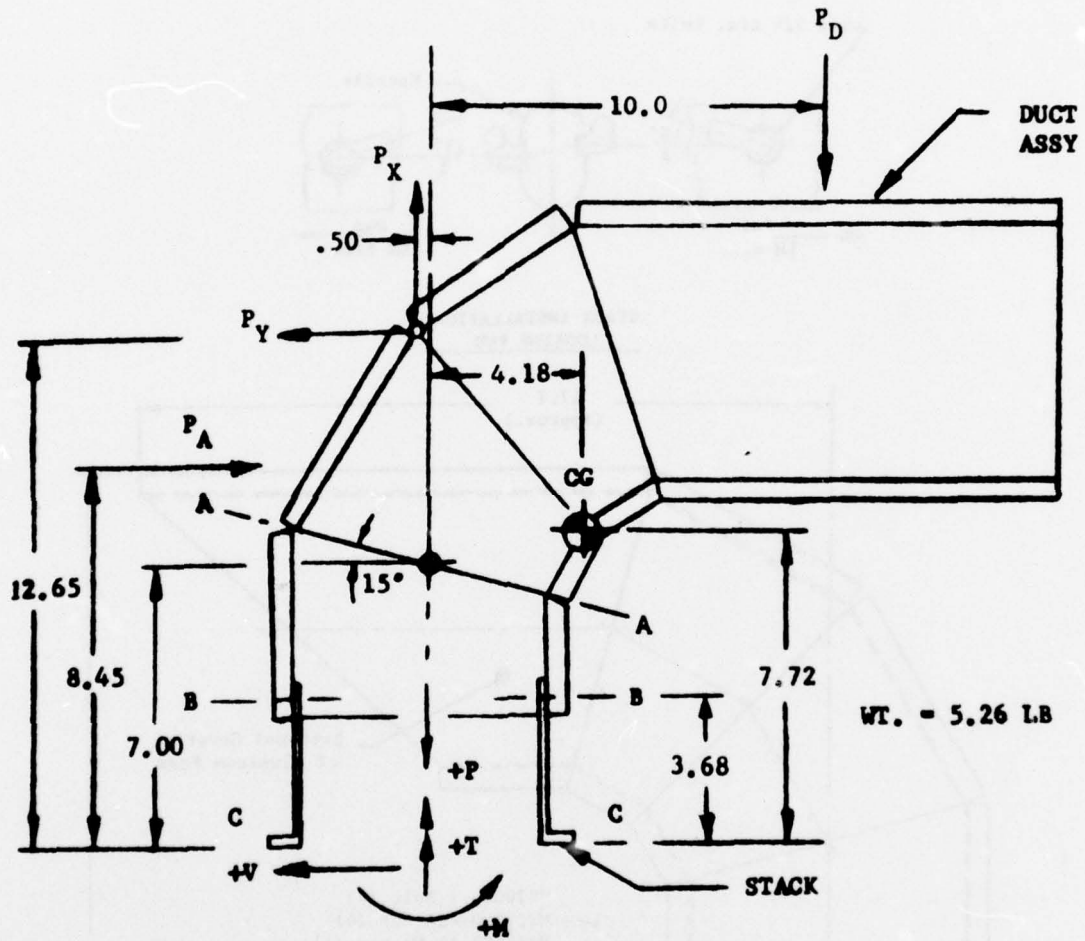

Figure 2. Engineering Drawing of an IR Suppressor.

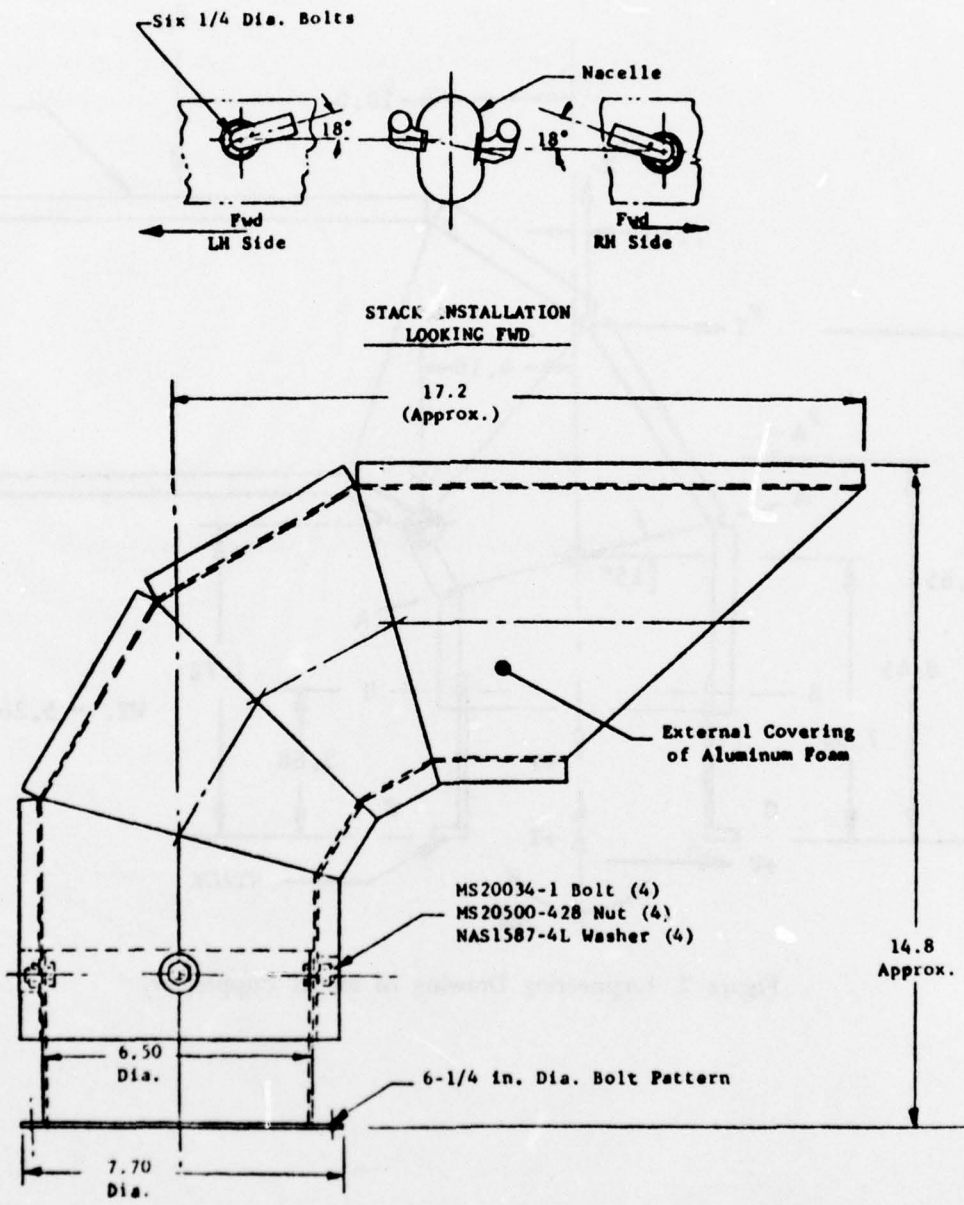
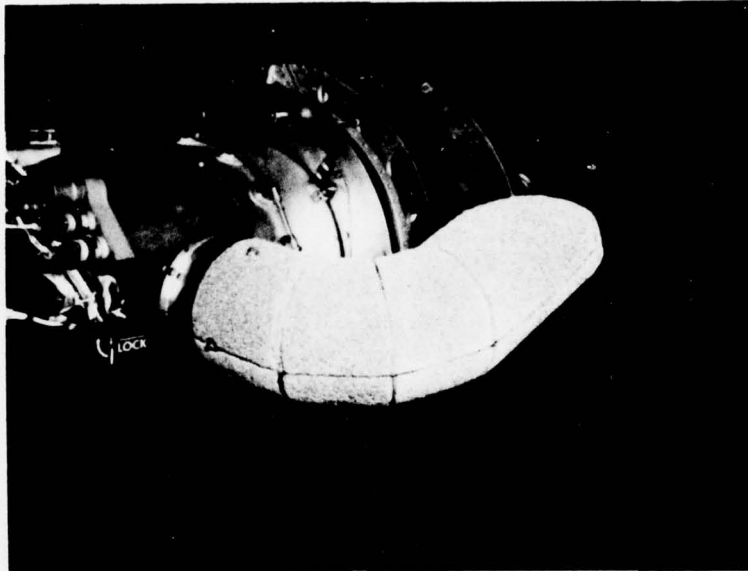
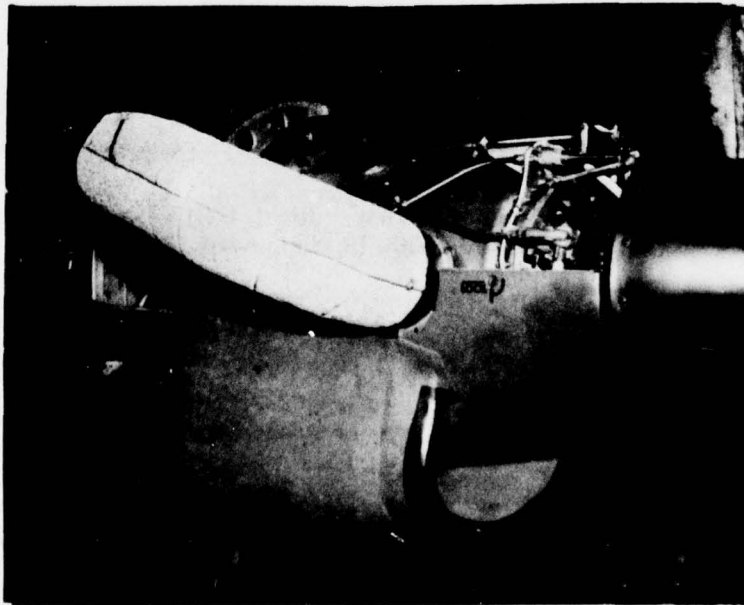

Figure 3. IR Suppressor Detail Drawings.



**Photo 8. Front View - Right U-21A Engine (No. 2)
With IR Suppressors Installed.**



**Photo 9. Left Front Quarter View - Right U-21A Engine (No. 2)
Left Exhaust Stub With IR Suppressor Installed.**

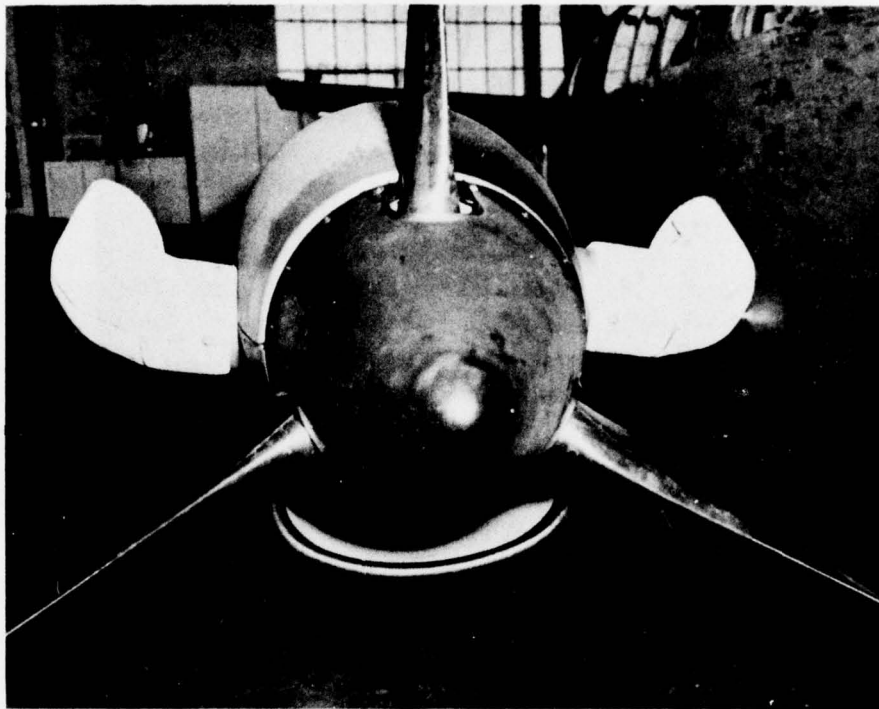

**Photo 10. Right Front Quarter View - Right U-21A Engine (No. 2)
Right Exhaust Stub With IR Suppressor Installed.**

APPENDIX C. INSTRUMENTATION

1. The test instrumentation on the U-21A aircraft, serial number 66-18008, was installed, calibrated, and maintained by USAAEFA personnel. A list of all test instrumentation is presented below. Photos 1 through 4 show the cockpit instrument panel, auxiliary instrument panel, and the cabin location and installation of the magnetic tape package and associated hardware.

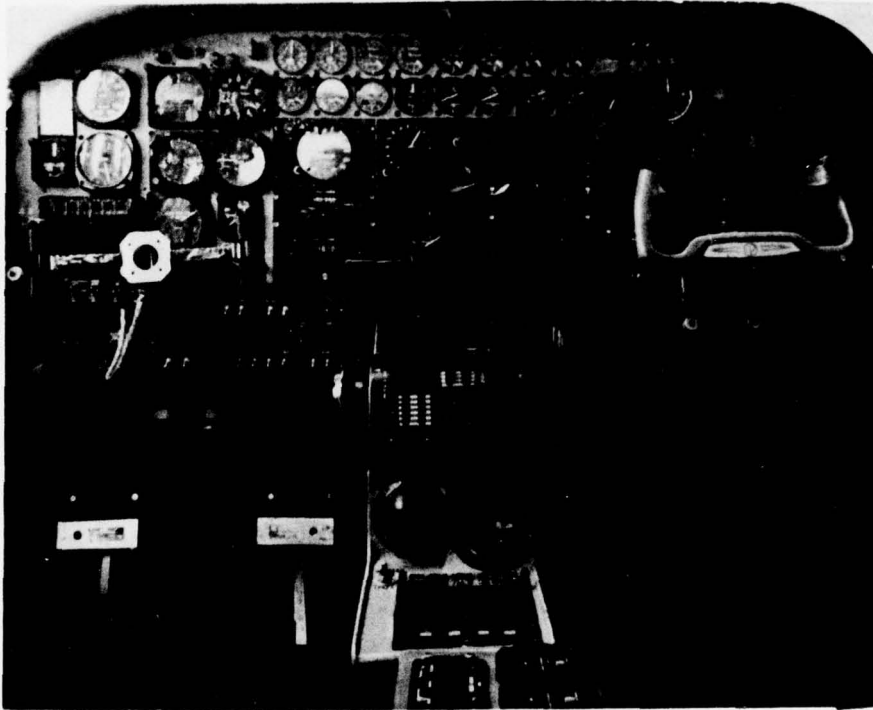

Photo 1. Cockpit Instrument Panel.

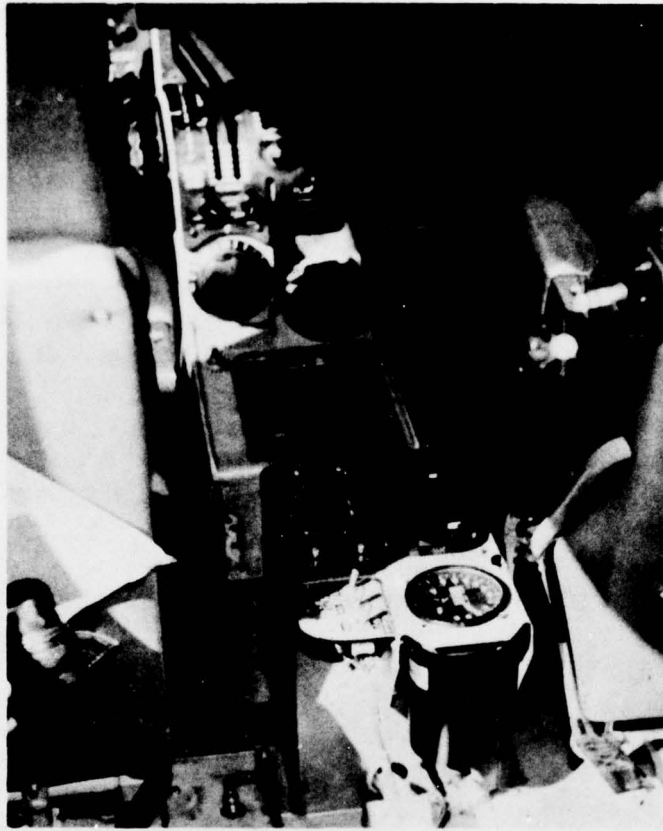
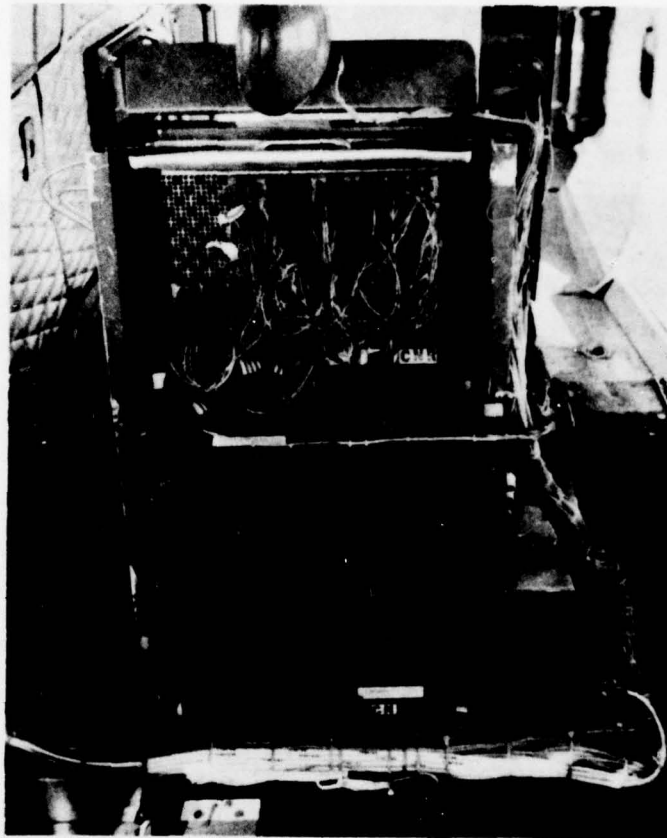
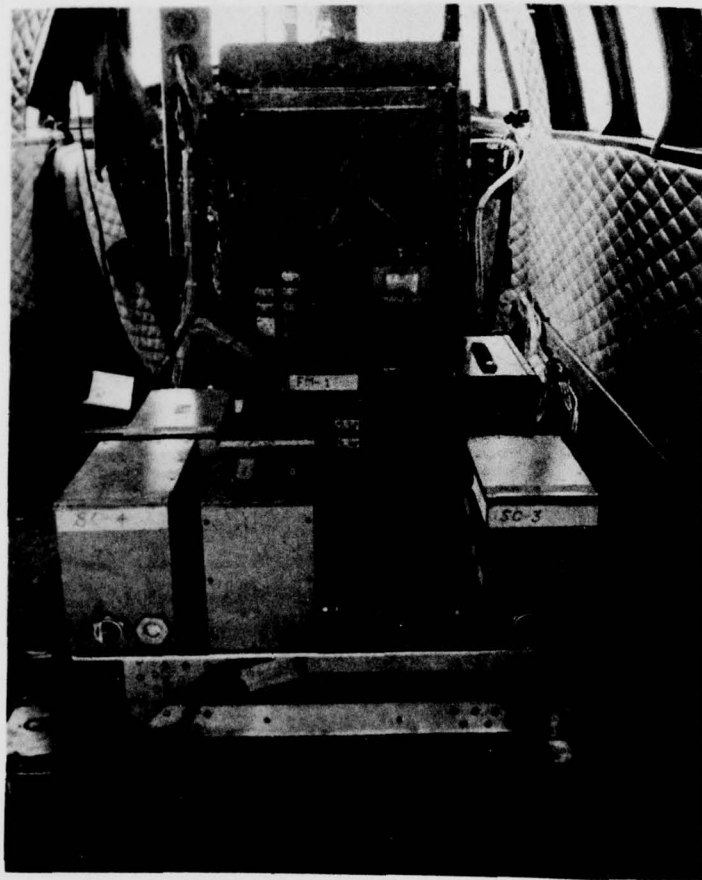

Photo 2. Auxiliary Instrument Panel.



**Photo 3. Magnetic Tape Unit.
(front end facing aft)**



**Photo 4. Magnetic Tape Unit
(aft end facing forward)**

2. In addition to the instrumentation listed below, the aircraft was also equipped with the following special instrumentation:

a. A pitot-static boom mounted at right wing station (WS) 211.92, which incorporates angle-of-attack and angle-of-sideslip vanes and a Rosemount outside air temperature probe (photo 5).

b. A C-band beacon installed in the nose compartment avionics bay to permit positive radar tracking for the radar airspeed calibration.

c. A microswitch mounted on the nose wheel strut torque knee and connected electrically to an amber light on the pilot instrument panel to give positive indication of nose wheel lift-off during takeoff performance tests.

Instrument Panel

Pilot airspeed (ship's system)
Pilot airspeed (boom)
Copilot altimeter (ship's system)
Pilot altimeter (boom)
Center-of-gravity normal acceleration
Digital interstage turbine temperature
(left and right engine)
Left and right engine gas producer tachometer
Left and right engine torquemeter
Left and right engine torquemeter (ship's system)
Left and right engine torquemeter (sensitive)
Left and right propeller (power turbine) tachometer
Left and right fuel flow
Angle of sideslip
Angle of attack
Wing surface temperatures
Exhaust gas stream temperature

Auxiliary Instrument Panel

Left and right engine fuel flow and totalizers
Outside air temperature (boom)
Time code generator

PCM Magnetic Tape

Time
Airborne/brake release event
Stall warning event
Pilot/engineer event
Left-hand fuel counter
Right-hand fuel counter

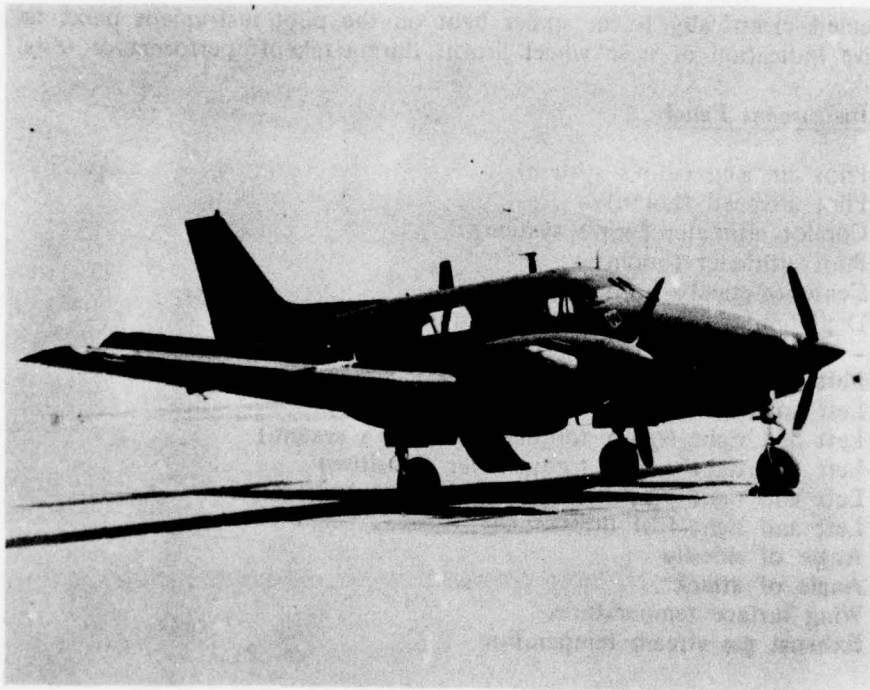

Photo 5. Flight Test Pitot-Static Boom Installation.

Altitude (boom)
Airspeed (boom)
Left-hand power turbine speed
Right-hand power turbine speed
Left-hand gas producer speed
Right-hand gas producer speed
Left-hand engine torque
Right-hand engine torque
Left-hand interstage turbine temperature
Right-hand interstage turbine temperature
Left-hand fuel flow
Right-hand fuel flow
Outside air temperature
Angle of attack
Angle of sideslip
Pitch attitude
Roll attitude
Yaw attitude
Pitch rate
Roll rate
Yaw rate
Center-of-gravity normal acceleration
Longitudinal stick position
Lateral stick position
Rudder pedal position
Longitudinal stick force
Lateral stick force
Rudder pedal force
Elevator surface position
Aileron surface position
Rudder surface position
Flap surface position

APPENDIX D. TEST TECHNIQUES AND DATA ANALYSIS METHODS

GENERAL

1. This appendix amplifies some of the data reduction and analysis methods used to evaluate the U-21A aircraft (refs 4 through 7, app A). The topics discussed include glide, climb, level flight, takeoff and landing performance, and weight and balance computations. All calculated parameters were corrected to account for additional drag due to external test instrumentation.

PERFORMANCE

2. The propeller-feathered engine-off glide method was used to develop the base-line drag polar for the U-21A in all three phases of testing (basic airplane, LR-painted airplane, and LR-painted airplane with IR suppressors installed). Level flight performance tests were conducted using the constant pressure altitude method, and the sawtooth-climb method was used for climb performance. All test data were converted into nondimensional coefficients which were used to develop the base-line drag polar and the final generalized equations for each phase of testing. The equations were then used to predict aircraft performance data at conditions not specifically tested. Because of the drag of the flight test pitot-static boom, additional data were obtained with the boom removed to determine its contribution to the drag of the airplane. All flight test data were then corrected for the ΔC_{D_0} shift ($\Delta C_{D_0} = 0.001$) due to the boom installation.

3. For propeller-feathered glide tests, the aircraft was stabilized in a descent at a constant airspeed with both engines shut off and the propellers feathered. Prior to shutting down the engines, the test instrumentation magnetic tape package was switched from primary aircraft power to the emergency 24-volt battery power. The airspeed range (1.1VS to VMO) (stall airspeed to maximum operating airspeed) was investigated over the target altitude band. The following technique was used to develop the base-line drag coefficient equation:

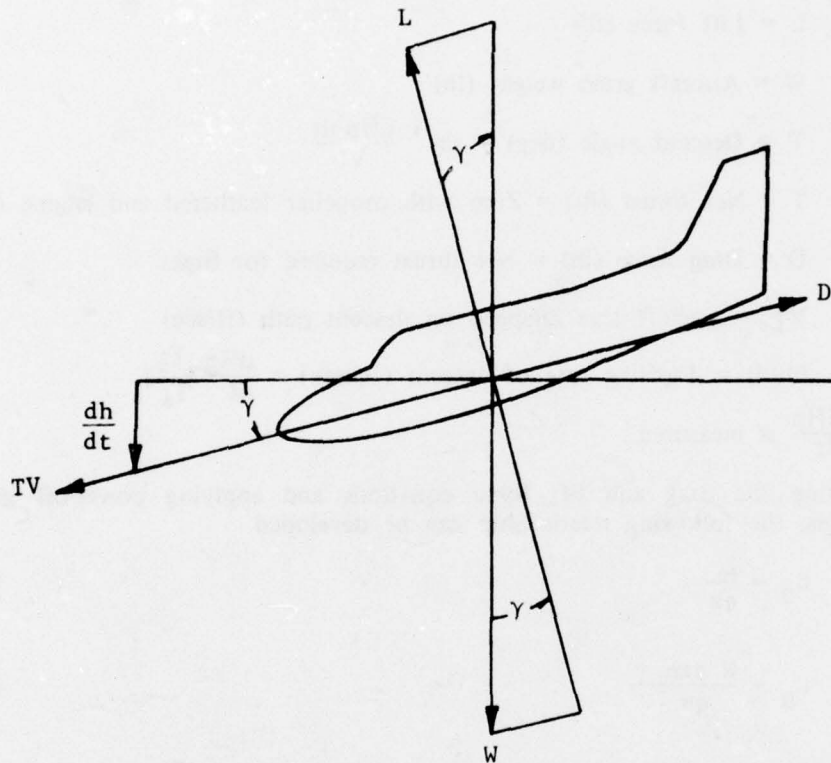

$$L = W \cos \gamma \quad (1)$$

$$D = T - W \sin \gamma \quad (2)$$

$$DV = T V_T - W V \sin \gamma \quad (3)$$

$$-V \sin \gamma = dh/dt = \frac{TV - DV}{W} \quad (4)$$

Where:

L = Lift force (lb)

W = Aircraft gross weight (lb)

γ = Descent angle (deg) = $\sin^{-1} \frac{dHp/dt}{V_t}$

T = Net thrust (lb) = Zero with propeller feathered and engine off

D = Drag force (lb) = Net thrust required for flight

V_T = Aircraft true airspeed on descent path (ft/sec)

dh/dt = Tapeline rate of descent (ft/min) = $\frac{dHp}{dt} \left(\frac{T_T}{T_S} \right)$

Where $\frac{dHp}{dt}$ is measured.

Considering the drag and lift force equations and applying power-off glide conditions, the following relationship can be developed.

$$C_D = \frac{D}{qS} \quad (5)$$

$$C_D = \frac{W \sin \gamma}{qS} \quad (6)$$

$$C_L = \frac{L}{qS} \quad (7)$$

$$C_L = \frac{W \cos \gamma}{qS} \quad (8)$$

Where:

C_D = Coefficient of drag

$q = 1/2 \rho V^2$ (lb/ft²) dynamic pressure

S = Wing area = 279.74 ft²

C_L = Coefficient of lift

ρ = Air density (slug/ft³)

The base-line coefficient of drag ($C_{D_{BL}}$) was then developed by plotting C_D versus C_L^2 and fitting a first order equation to the test points using a linear regression.

(diagram)
(equation 9)

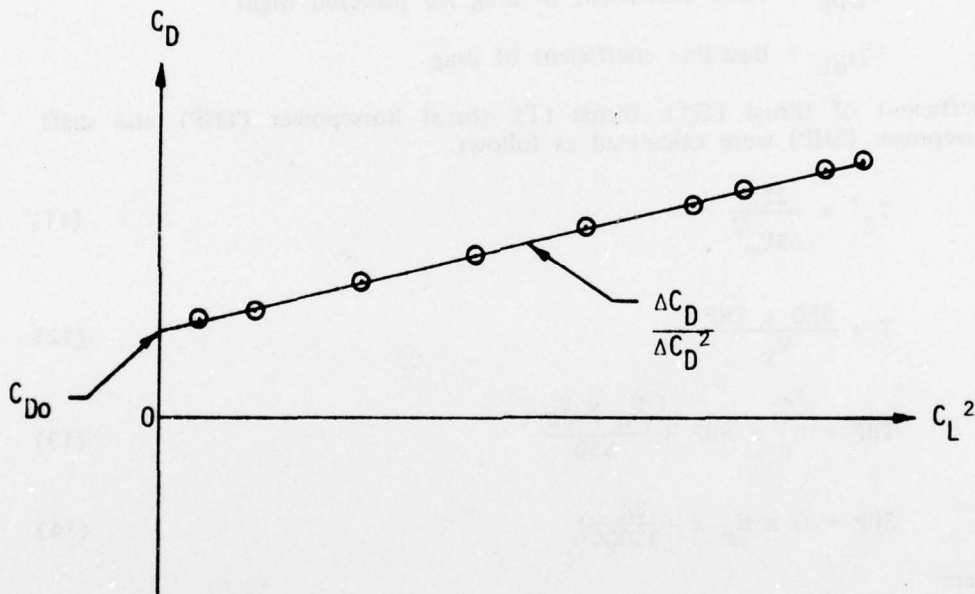

$$C_{D_{BL}} = C_{D0} + \frac{\Delta C_D}{\Delta C_L^2} C_L^2 \quad (9)$$

4. During powered flight, the drag of the aircraft increased with thrust. To reflect the change, the basic drag equation was modified.

$$\Delta C_{D_{PF-BL}} = C_{D_{PF}} - C_{D_{BL}} \quad (10)$$

Where:

$\Delta C_{D_{PF-BL}}$ = Increased coefficient of drag due to thrust effect

$C_{D_{PF}}$ = Total coefficient of drag for powered flight

$C_{D_{BL}}$ = Base-line coefficient of drag

Coefficient of thrust (T_C'), thrust (T), thrust horsepower (THP), and shaft horsepower (SHP) were calculated as follows:

$$T_C' = \frac{2T}{\rho S V_T^2} \quad (11)$$

$$T = \frac{550 \times THP}{V_T} \quad (12)$$

$$THP = \eta_p \times SHP + \frac{F_n \times V_T}{550} \quad (13)$$

$$SHP = Q \times N_p \times \left(\frac{2\pi}{33000} \right) \quad (14)$$

Where:

T_C' = Coefficient of thrust

T = Thrust (lb)

THP = Thrust horsepower

η_p = Propeller efficiency (obtained from propeller chart)

SHP = Shaft horsepower

F_n = Jet thrust (lb) (obtained from curve 1202-2, sheets 1-7 of UACL Spec. No. 584, Apr 15, 1967)

Q = Engine torque expressed at propeller rotational speed (ft/lb)

N_p = Propeller speed (rpm)

The values of $\Delta C_{D_{PF-BL}}$ and T_C' were then analyzed to develop a generalized equation that represented the change in drag due to thrust. A linear fitting was used.

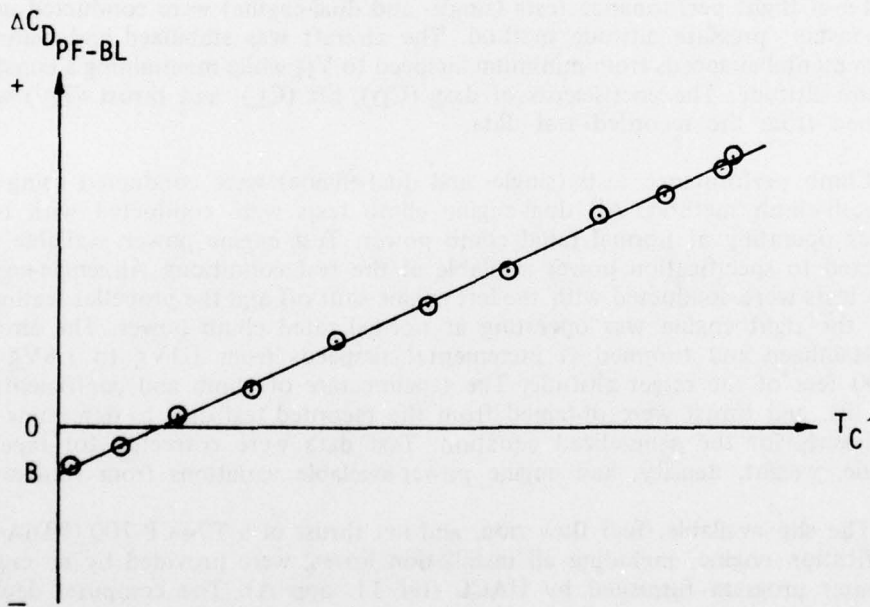

$$\Delta C_{D_{PF-BL}} = AT_C' + B \quad (15)$$

From equation 10,

$$C_{D_{PF}} = C_{D_{BL}} + \Delta C_{D_{PF-BL}}$$

or

$$C_{D_{PF}} = C_{D_{BL}} + AT_C'^2 + BT_C' + C \quad (16)$$

Equation 16 represents the generalized equation for all level flight and climb performance in either single- or dual-engine operation.

5. Level flight performance tests (single- and dual-engine) were conducted using the constant pressure altitude method. The aircraft was stabilized and trimmed at incremental airspeeds from minimum airspeed to V_H while maintaining a constant pressure altitude. The coefficients of drag (C_D), lift (C_L), and thrust (T_C') were obtained from the recorded test data.

6. Climb performance tests (single- and dual-engine) were conducted using the sawtooth-climb method. All dual-engine climb tests were conducted with both engines operating at normal rated climb power. Test engine power available was corrected to specification power available at the test conditions. All single-engine climb tests were conducted with the left engine shut off and the propeller feathered while the right engine was operating at normal rated climb power. The aircraft was stabilized and trimmed at incremental airspeeds from $1.1V_S$ to $1.8V_S$ for ± 1000 feet of the target altitude. The tapeline rate of climb and coefficients of drag, lift, and thrust were obtained from the recorded test data to determine the coefficients for the generalized equation. Test data were corrected for tapeline altitude, weight, density, and engine power-available variations from standard.

7. The shp available, fuel flow rate, and net thrust of a T74-CP-700 (PT6A-20) specification engine, including all installation losses, were provided by an engine computer program furnished by UACL (ref 11, app A). The computer deck is based on the minimum performing engine that has accumulated the maximum allowable time before overhaul. For this reason, the calculated aircraft performance data, which were based on the specification engine, were always less than the observed test data. In order to simulate losses due to IR suppressor installation, 12 shp was input to the computer deck as additional accessory losses (ref para 72). The test engines, SN's PC-E-30009 and PC-E-21153, used for this evaluation were production engines, each with 112 hours since overhaul as of the start of flight testing. The propeller efficiency chart was furnished by BAC and is presented in table 1.

Table 1. Propeller Efficiency Chart.

| C_p | 0.040 | 0.050 | 0.060 | 0.070 | 0.080 | 0.090 | 0.100 | 0.110 | 0.120 | 0.140 | 0.150 | 0.160 | 0.170 | 0.190 |
|------------------|-------|-------|-------|-------|-------|-------|-------|-------|-------|-------|-------|-------|-------|-------|
| J = 0.200 effi = | 0.430 | 0.401 | 0.380 | 0.370 | 0.340 | 0.320 | 0.300 | 0.280 | 0.260 | 0.210 | 0.180 | 0.160 | 0.140 | 0.120 |
| J = 0.300 effi = | 0.580 | 0.550 | 0.525 | 0.500 | 0.475 | 0.455 | 0.430 | 0.415 | 0.390 | 0.350 | 0.330 | 0.300 | 0.280 | 0.260 |
| J = 0.400 effi = | 0.680 | 0.662 | 0.640 | 0.620 | 0.600 | 0.575 | 0.550 | 0.530 | 0.505 | 0.460 | 0.430 | 0.420 | 0.400 | 0.370 |
| J = 0.500 effi = | 0.755 | 0.740 | 0.720 | 0.704 | 0.680 | 0.665 | 0.640 | 0.620 | 0.600 | 0.560 | 0.530 | 0.510 | 0.482 | 0.440 |
| J = 0.600 effi = | 0.782 | 0.780 | 0.773 | 0.762 | 0.749 | 0.730 | 0.714 | 0.695 | 0.675 | 0.636 | 0.620 | 0.595 | 0.575 | 0.530 |
| J = 0.700 effi = | 0.798 | 0.812 | 0.810 | 0.804 | 0.791 | 0.780 | 0.768 | 0.754 | 0.738 | 0.705 | 0.680 | 0.668 | 0.650 | 0.610 |
| J = 0.800 effi = | 0.822 | 0.839 | 0.837 | 0.832 | 0.825 | 0.818 | 0.808 | 0.796 | 0.783 | 0.756 | 0.739 | 0.725 | 0.708 | 0.675 |
| J = 0.900 effi = | 0.832 | 0.846 | 0.851 | 0.849 | 0.844 | 0.839 | 0.834 | 0.827 | 0.818 | 0.796 | 0.782 | 0.770 | 0.755 | 0.725 |
| J = 1.000 effi = | 0.834 | 0.849 | 0.859 | 0.861 | 0.858 | 0.855 | 0.851 | 0.845 | 0.839 | 0.825 | 0.817 | 0.806 | 0.796 | 0.770 |
| J = 1.100 effi = | 0.833 | 0.848 | 0.861 | 0.870 | 0.870 | 0.867 | 0.863 | 0.859 | 0.854 | 0.842 | 0.837 | 0.830 | 0.823 | 0.804 |
| J = 1.200 effi = | 0.830 | 0.846 | 0.857 | 0.866 | 0.871 | 0.871 | 0.870 | 0.867 | 0.864 | 0.856 | 0.850 | 0.844 | 0.839 | 0.828 |
| J = 1.300 effi = | 0.824 | 0.843 | 0.854 | 0.862 | 0.868 | 0.871 | 0.872 | 0.871 | 0.870 | 0.864 | 0.861 | 0.856 | 0.850 | 0.841 |
| J = 1.400 effi = | 0.816 | 0.839 | 0.852 | 0.858 | 0.864 | 0.867 | 0.871 | 0.872 | 0.871 | 0.868 | 0.865 | 0.863 | 0.860 | 0.850 |
| J = 1.500 effi = | 0.809 | 0.833 | 0.848 | 0.856 | 0.861 | 0.866 | 0.870 | 0.871 | 0.872 | 0.871 | 0.869 | 0.867 | 0.864 | 0.860 |
| J = 1.600 effi = | 0.801 | 0.825 | 0.843 | 0.853 | 0.857 | 0.863 | 0.867 | 0.870 | 0.871 | 0.872 | 0.871 | 0.869 | 0.867 | 0.864 |
| J = 1.700 effi = | 0.795 | 0.818 | 0.835 | 0.851 | 0.855 | 0.859 | 0.863 | 0.867 | 0.870 | 0.871 | 0.872 | 0.870 | 0.869 | 0.867 |
| J = 1.800 effi = | 0.786 | 0.810 | 0.828 | 0.846 | 0.853 | 0.857 | 0.860 | 0.863 | 0.867 | 0.870 | 0.871 | 0.871 | 0.870 | 0.870 |
| J = 1.900 effi = | 0.780 | 0.820 | 0.821 | 0.837 | 0.851 | 0.854 | 0.858 | 0.861 | 0.863 | 0.867 | 0.868 | 0.868 | 0.868 | 0.868 |

3-blade Hartzell propeller.

$$J = (101.4) (V_T) / N_p D$$

$$C_p = (SHP) / 200 \sigma \left(\frac{N_p}{1000} \right)^3 \left(\frac{D}{10} \right)^3$$

J = Advance ratio

SHP = Shaft horsepower

$\sigma = \rho / \rho_{SSL}$

N_p = Propeller speed (rpm)

D = Propeller diameter (7.79 ft)

V_T = True airspeed (kt)

8. Ambient test temperatures (T_a) were obtained by correcting the indicated test temperature (T_i) for instrument error (ΔT_{ic}) and for compressibility (ΔT_c).

$$T_a = T_i + \Delta T_{ic} + \Delta T_c \quad (17)$$

9. Pressure altitudes were obtained by correcting indicated pressure altitudes (H_{pi}) for instrument error (ΔH_{pic}) and static source position error (ΔH_{pc}).

$$H_p = H_{pi} + \Delta H_{pic} + \Delta H_{pc} \quad (18)$$

10. The density ratio (σ) was determined from the following relationship:

$$\sigma = \left(\frac{T_{SSL}}{T_a} \right) \left(\frac{P_a}{P_{SSL}} \right) \quad (19)$$

Where:

T_{SSL} = Standard-day static sea-level temperature

P_{SSL} = Standard-day static sea-level pressure.

11. The density altitudes were determined from the test density ratio (σ test) and the US Standard Atmosphere 1962 tables.

12. True airspeeds (V_T) were determined from the test altitude air density ratio (σ) and calibrated airspeed, as follows:

$$V_T = \frac{V_{cal}}{\sqrt{\sigma}} \quad (20)$$

Takeoff Performance

13. Takeoff performance was evaluated using the General William J. Fox Airfield in Lancaster, California. The airport elevation is 2349 feet above mean sea level and has one east-west runway (6-24) which is 150 by 5000 feet with an effective gradient of .022 percent uphill to the west. All takeoffs were recorded by using two Fairchild Flight Analyzers. Each takeoff roll commenced at the same point on the runway, with brakes held until takeoff power had been achieved and stabilized for 5 seconds. Power was maintained at maximum allowable torque limits (1315 ft-lb) throughout the takeoff sequence. Lift-off airspeeds of 110 KIAS to 1.1V_S were used with rotation and nose wheel lift-off 3 to 5 knots prior to the desired lift-off airspeed. Immediately after lift-off, the landing gear was retracted and the airplane attitude adjusted to maintain the lift-off airspeed until reaching an altitude of 5000 feet above ground level (AGL). Time and distance information

for ground roll to lift-off and total distance to 50 feet AGL were recorded from the Fairchild Flight Analyzer plates. Time and airspeed from brake release to main wheel lift-off were recorded from the PCM magnetic tape on board the aircraft.

14. Takeoff performance data were corrected to standard conditions using empirical equations from reference 6, appendix A.

$$S_{g_s} = S_{g_t} \left(\frac{W_s}{W_t}\right)^{2.6} \left(\frac{\sigma_t}{\sigma_s}\right)^{1.9} \left(\frac{N_t}{N_s}\right)^{0.7} \left(\frac{P_{a_t}}{P_{a_s}}\right)^{0.5} \quad (21)$$

$$S_{a_s} = S_{a_t} \left(\frac{W_s}{W_t}\right)^{2.6} \left(\frac{\sigma_t}{\sigma_s}\right)^{1.9} \left(\frac{N_t}{N_s}\right)^{.8} \left(\frac{P_{a_t}}{P_{a_s}}\right)^{0.6} \quad (22)$$

Where:

Subscript s refers to standard data

Subscript t refers to test data

S_g = Ground distance

S_a = Air distance

W = Gross weight (lb)

σ = Air density ratio

N = Propeller speed (rpm)

P = Air pressure (inches of mercury)

15. The following simplifying assumptions were made:

a. Because of the essentially level runway (.022 percent), the slope had essentially no effect (less than .003 percent), and therefore, $S_{g_{SL}} \cong S_g$.

b. Since propeller rpm was constant, $\frac{N_T}{N_S} \cong 1$

c. Since wind velocity was zero for all takeoffs, $S_w = S_{g_w} = S_g$.

Therefore, the following equations were the ones used for all takeoff performance calculations.

$$S_{g_s} = S_{g_t} \left(\frac{W_s}{W_t}\right)^{2.6} \left(\frac{\sigma_t}{\sigma_s}\right)^{1.9} \left(\frac{P_{a_t}}{P_{a_s}}\right)^{0.5} \quad (23)$$

$$S_{a_s} = S_{a_t} \left(\frac{W_s}{W_t}\right)^{2.6} \left(\frac{\sigma_t}{\sigma_s}\right)^{1.9} \left(\frac{P_{a_t}}{P_{a_s}}\right)^{0.6} \quad (24)$$

AIRSPEED CALIBRATION

16. The U-21A boom and ship's pitot-static system were calibrated during base-line tests, using both space positioning radar and the pace method using the two calibrated boom pitot-static systems on the F-51D pace airplane. The U-21A boom and ship's pitot-static systems were again calibrated using the F-51D after the U-21A aircraft had been painted with the LR paint. Data reduction techniques using the pace method were standard, with calibrated airspeeds (V_{ca}) obtained by correcting indicated airspeed (V_i) for instrument error (ΔV_{ic}) and position error (ΔV_{pc}). Test techniques and data reduction techniques using space positioning radar data were based on techniques developed at USAAEFA and published in a technical note (ref 9, app A). For the flights with radar tracking, reciprocal headings were flown. Temperature data were corrected for ram-rise due to airspeed before further use by the following equation:

$$OAT_{static} = \frac{(OAT_{ic} + 273.15)}{1 + \left(\frac{V_{ic}^2}{2187673.8 \times \frac{P_a}{P_{SSL}}}\right)} - 273.15 \quad (25)$$

Where V_{ic} is the indicated airspeed corrected for instrument error and P/P is the pressure ratio from the atmospheric tables, using the instrument-corrected pressure altitude ($H_{p_{ic}}$) for each system as the base-line pressure altitude for that system. The pressure ratio and static outside air temperature thus obtained were then used to compute the square root of the density ratio, as follows:

$$\sqrt{\sigma} = \sqrt{\frac{\left(\frac{P_a}{P_{SSL}}\right) 288.15}{OAT_{static} + 273.15}} \quad (26)$$

Radar true velocities (V_T) were changed to calibrated airspeed in the following manner:

$$V_{cal} = V_T \sqrt{\sigma} \quad (27)$$

The effects of crosswind were subtracted from the radar-tracked velocities by averaging the two calibrated airspeeds obtained on two reciprocal airspeed runs and multiplying it by the cosine of the average differential track ($\Delta\psi$) from true 180 degrees (with respect to the ground) on the reciprocal heading points as follows:

$$\text{Avg } \Delta\psi = \frac{(|\text{radar track}_1 - \text{radar track}_2| - 180)}{2} \quad (28)$$

$$\text{Radar } V_{cal(\text{wind corrected})} = V_{cal} \cos(\text{avg } \Delta\psi) \quad (29)$$

Position error information was then calculated by the following method:

$$\Delta H_{pc} = \text{Radar } V_{cal(\text{wind corrected})} - \text{avg } V_{ic} \quad (30)$$

Where avg V_{ic} is the average instrument-corrected airspeed for the selected system over two reciprocal runs.

The agreement between the radar tracking and the pace method indicates that the curves shown in figures 65 and 70, appendix F, are representative of the current position error correction.

DYNAMIC STABILITY

17. Dynamic stability characteristics were tested using techniques described in references 5 and 7, appendix A. Data recorded from dynamic testing were presented as time histories of the pertinent parameters that describe the motion of the aircraft. Analyses of these time histories were performed to determine the resulting damping ratio (ζ) and undamped natural frequencies (ω_n). The undamped natural frequencies and damping ratios were derived by two methods, the logarithmic decrement and time ratio method, for all conditions tested. For lightly damped oscillations ($\zeta < .5$) the following technique was used to eliminate the requirement to know the steady-state values.

$$\zeta\omega_n = \frac{\ln \left(\frac{D_1}{D_2} \right)}{\frac{T}{2}} \quad (31)$$

$$\omega_n \sqrt{1-\zeta^2} = \frac{2\pi}{T} \quad (32)$$

Where $\omega_n \sqrt{1 - \zeta^2} = \omega$ or the imaginary part on a root locus plot and $\zeta \omega_n$ the real part. For calculation of the undamped natural frequencies (ω_n) of the motion in radians per second and the damping factor, the following relationships were used:

$$\tan \epsilon_d = \frac{\zeta}{\sqrt{1-\zeta^2}} = \frac{\zeta \omega_n}{\omega_n \sqrt{1-\zeta^2}} = \frac{\ln\left(\frac{D_1}{D_2}\right)}{\pi} \quad (33)$$

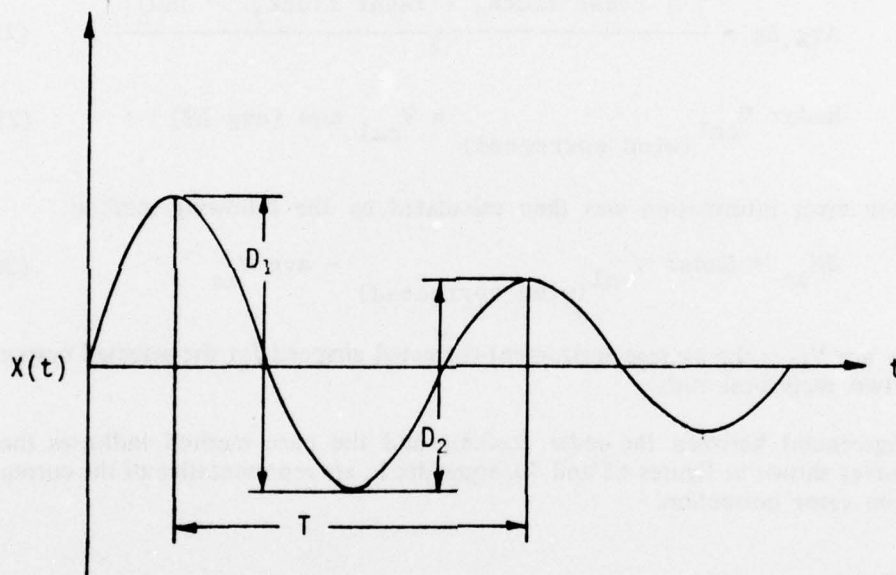

And since

$$\sin \epsilon_d = \zeta \quad (34)$$

then

$$\zeta = \sin^{-1} \epsilon_d \quad (35)$$

and

$$\cos \epsilon_d = \sqrt{1-\zeta^2} \quad (36)$$

therefore,

$$\omega_n = \frac{\omega_n \sqrt{1-\zeta^2}}{\cos \epsilon_d} = \frac{\frac{2\pi}{T}}{\cos \epsilon_d} \quad (37)$$

Roll Performance

18. Roll performance and characteristics were evaluated by using the techniques described in references 5 and 7, appendix A. The data recorded were presented as time histories of the pertinent parameters that describe the motion of the aircraft and analyzed to determine the roll mode time constant, steady-state roll rates, and the character of the response. Because of the adverse yaw and Dutch-roll characteristics of the U-21A, it was necessary to fair a curve through the Dutch-roll oscillation in order to determine the roll rate response. From this faired curve the time for the roll rate to reach 63.2 percent of steady state was measured and the roll mode time constant determined.

WEIGHT AND BALANCE

19. The aircraft weight and longitudinal cg were calculated prior to each weight and/or cg configuration change. The aircraft was weighed three times - once upon initial receipt of the aircraft, after instrumentation installation, and after application of the LR paint. In addition to these weighings, the longitudinal cg shift with fuel burnoff was measured during the initial weighing. The aircraft was weighed empty, then fuel was added in 10-gallon increments through a calibrated fuel pump, fuel specifics determined, and then the aircraft was weighed after each increment had been added. The nacelle tanks were filled first, and then the wing tanks. In this manner the cg shift was accurately determined and provided data for accurate cg determination during flight tests. By ensuring that fuel from the wing tanks was manually transferred to maintain full nacelle tanks at all times during the flight, the cg location for each test point could be calculated. A cross-plot of the longitudinal cg shift with fuel burnoff data presented in the operator's manual, and the cg shift data obtained with fuel addition during the initial weighing, verified the accuracy of the manual information.

APPENDIX E. HANDLING QUALITIES RATING SCALE

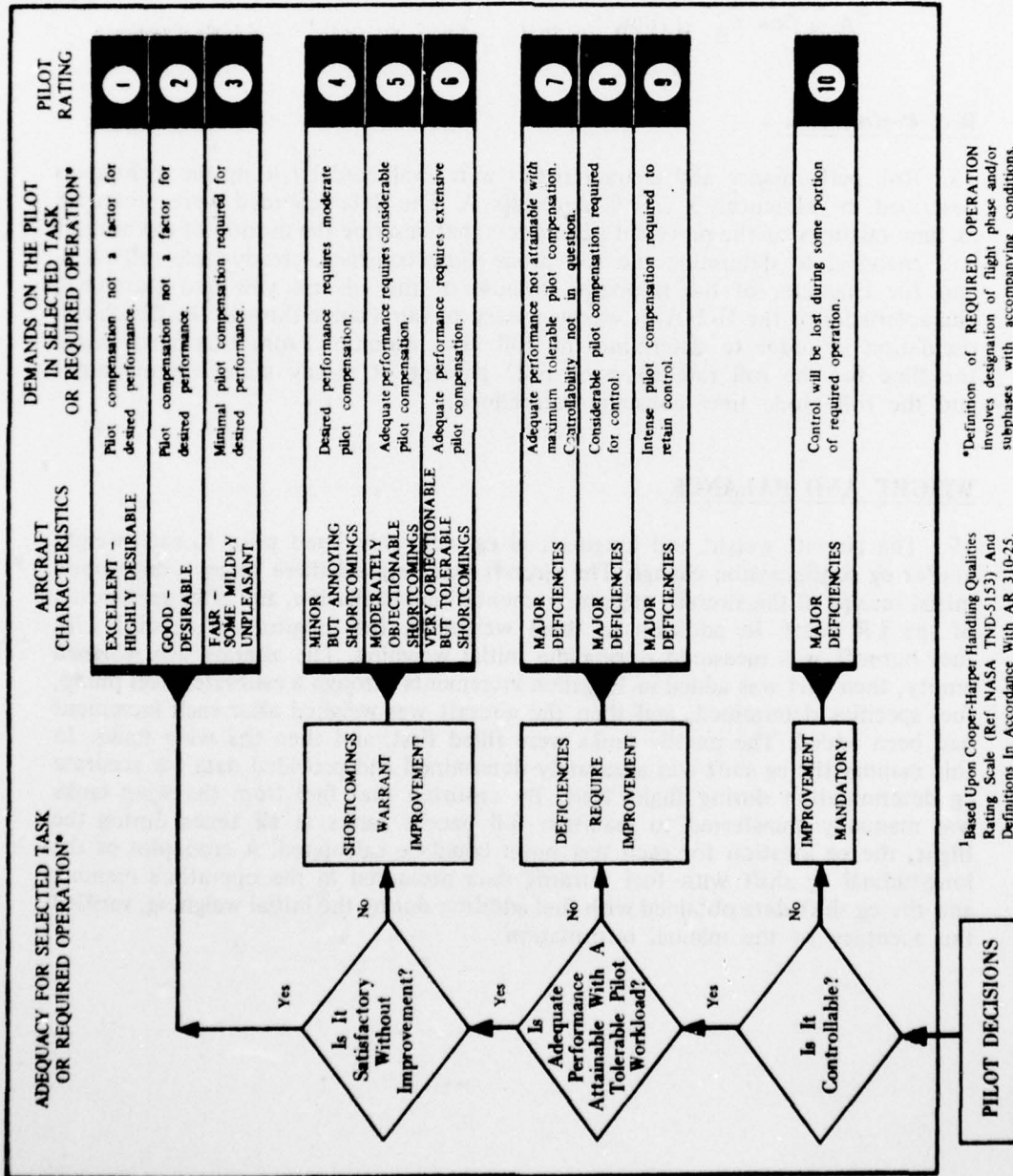

APPENDIX F. TEST DATA

INDEX

| <u>Figure</u> | <u>Figure Number</u> |
|--|----------------------|
| Standard Day Takeoff Performance | 1 |
| Dual-Engine Climb Performance | 2 |
| Calculated Dual-Engine Climb Performance | 3 |
| Single-Engine Climb Performance | 4 |
| Calculated Single-Engine Climb Performance | 5 |
| Dual-Engine Level Flight Performance | 6 and 7 |
| Calculated Dual-Engine Level Flight Performance Comparison | 8 |
| Single-Engine Level Flight Performance | 9 and 10 |
| Calculated Single-Engine Level Flight Performance Comparison | 11 |
| Stall Airspeed Variation | 12 through 14 |
| Control Positions in Trimmed Forward Flight | 15 and 16 |
| Static Longitudinal Stability | 17 and 18 |
| Static Lateral-Directional Stability | 19 through 24 |
| Dutch Roll | 25 |
| Aircraft Response Following an Aft Longitudinal Pulse | 26 |
| Aircraft Response Following a Longitudinal Control Doublet | 27 |
| Aircraft Response Following an Aft Longitudinal Pulse | 28 |
| Dynamic Longitudinal Stability (Phugoid) | 29 through 32 |
| Aircraft Response Following a Rudder Doublet | 33 |
| Dutch Roll | 34 |
| Aircraft Response Following a Rudder Doublet | 35 |
| Maneuvering Stability | 36 through 44 |
| Aircraft Response Following a Half-Inch Aft Longitudinal Step | 45 |
| Aircraft Response Following a Half-Deflection Lateral Step | 46 through 49 |
| Aircraft Response Following a Full-Deflection Lateral Step | 50 and 51 |
| Aircraft Response Following a Half-Deflection Lateral Step | 52 and 53 |

AD-A047 656

ARMY AVIATION ENGINEERING FLIGHT ACTIVITY EDWARDS AF--ETC F/6 17/4
AIRWORTHINESS QUALIFICATION EVALUATION U-21A AIRPLANE WITH LOW --ETC(U)
JAN 76 W A NORTON, R B SMITH

UNCLASSIFIED

USAAEFA-75-10

NL

2 OF 2

AD
A047656



END
DATE
FILMED
1 -78
DDC

| | |
|---|---------------|
| Aircraft Response Following a Full-Deflection Lateral Step | 54 and 55 |
| Roll Performance | 56 |
| Minimum Single-Engine Control Airspeed Variation With Altitude | 57 |
| Takeoff Performance | 58 through 60 |
| Referred Engine Characteristics | 61 through 64 |
| Airspeed Calibration | 65 and 66 |
| Altimeter Calibration | 67 through 70 |
| Propeller-Feathered Glide Drag Polar | 71 through 73 |
| Dual-Engine Level Flight Drag Polar | 74 and 75 |
| Single-Engine Level Flight Drag Polar | 76 and 77 |
| Dual-Engine Climb Drag Polar | 78 through 80 |
| Single-Engine Climb Drag Polar | 81 and 82 |

FIGURE 1
 STANDARD DAY TAKEOFF PERFORMANCE
 U-21A USA S/N 66-18008

- NOTES: 1. DAY ASPHALT RUNWAY
 2. STANDARD DAY CONDITIONS - 2180 FT ELEV
 3. LONG CG - 153.5(FWD)
 4. PROPELLER SPEED = 2200 RPM
 5. TAKEOFF CONFIGURATION
 6. ○ BASIC AIRCRAFT - SOLID LINE FAIRING
 7. □ IR PAINTED AIRCRAFT WITH IR SUPPRESSORS - DASHED LINE FAIRING
 8. GROSS WEIGHT = 9650 POUNDS.
 9. POWER AVAILABLE CORRECTED TO SPECIFICATION TAKEOFF POWER.

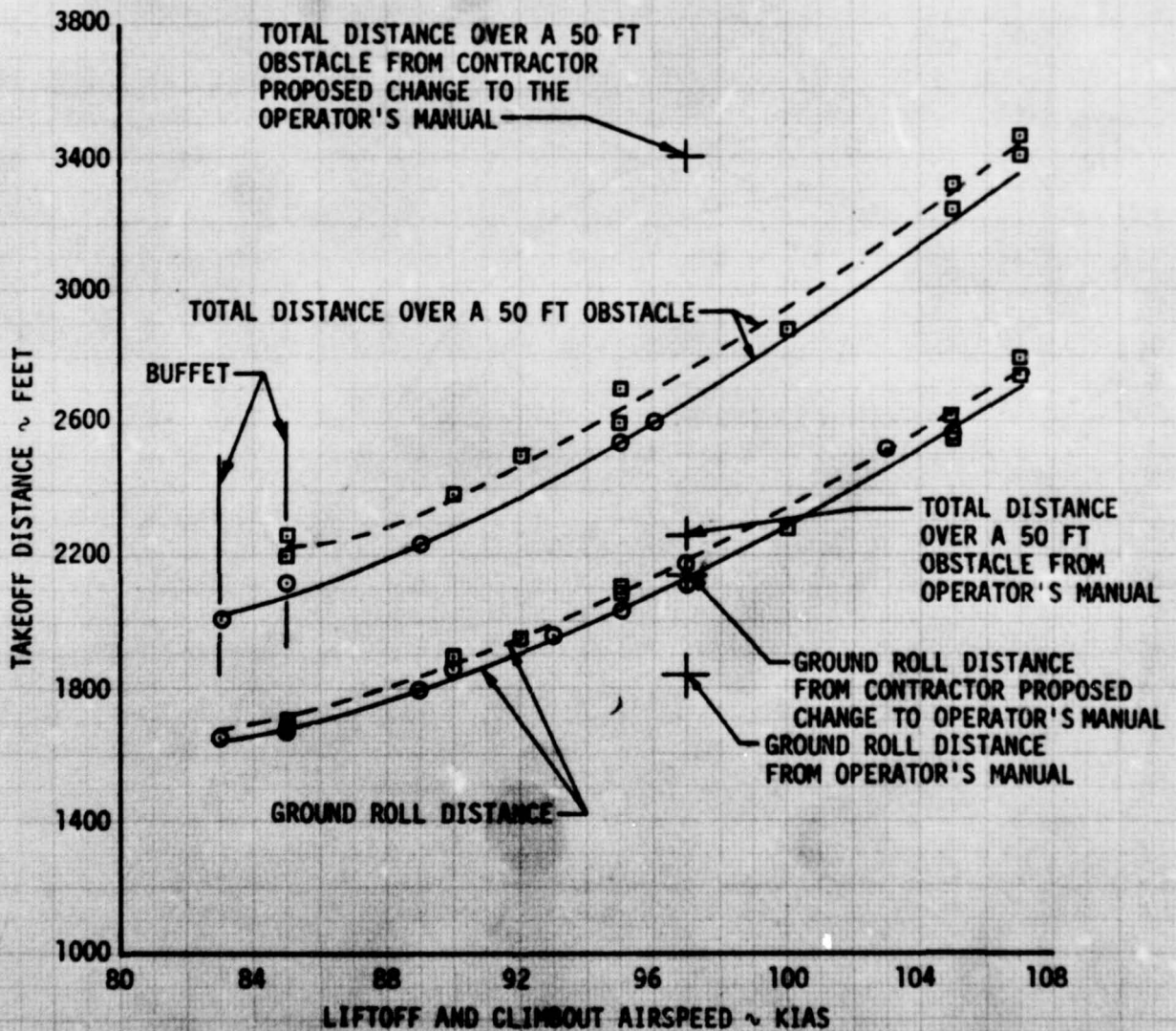

FIGURE 2
DUAL ENGINE CLIMB PERFORMANCE
U-21A USA S/N 66-18008

- NOTES:**
1. STANDARD DAY CONDITIONS = 10,000 FT
 2. GROSS WEIGHT = 9650 POUNDS.
 3. PROPELLER SPEED = 2000 RPM.
 4. ○ BASIC AIRCRAFT.
 5. □ IR PAINTED AIRCRAFT WITH STANDARD EXHAUST STUBS.
 6. △ IR PAINTED AIRCRAFT WITH IR SUPPRESSORS.
 7. NORMAL RATED CLIMB POWER (TEST ENGINES).
 8. CRUISE CONFIGURATION.
 9. POWER AVAILABLE FROM UAEL ENGINE DECK #1518B.

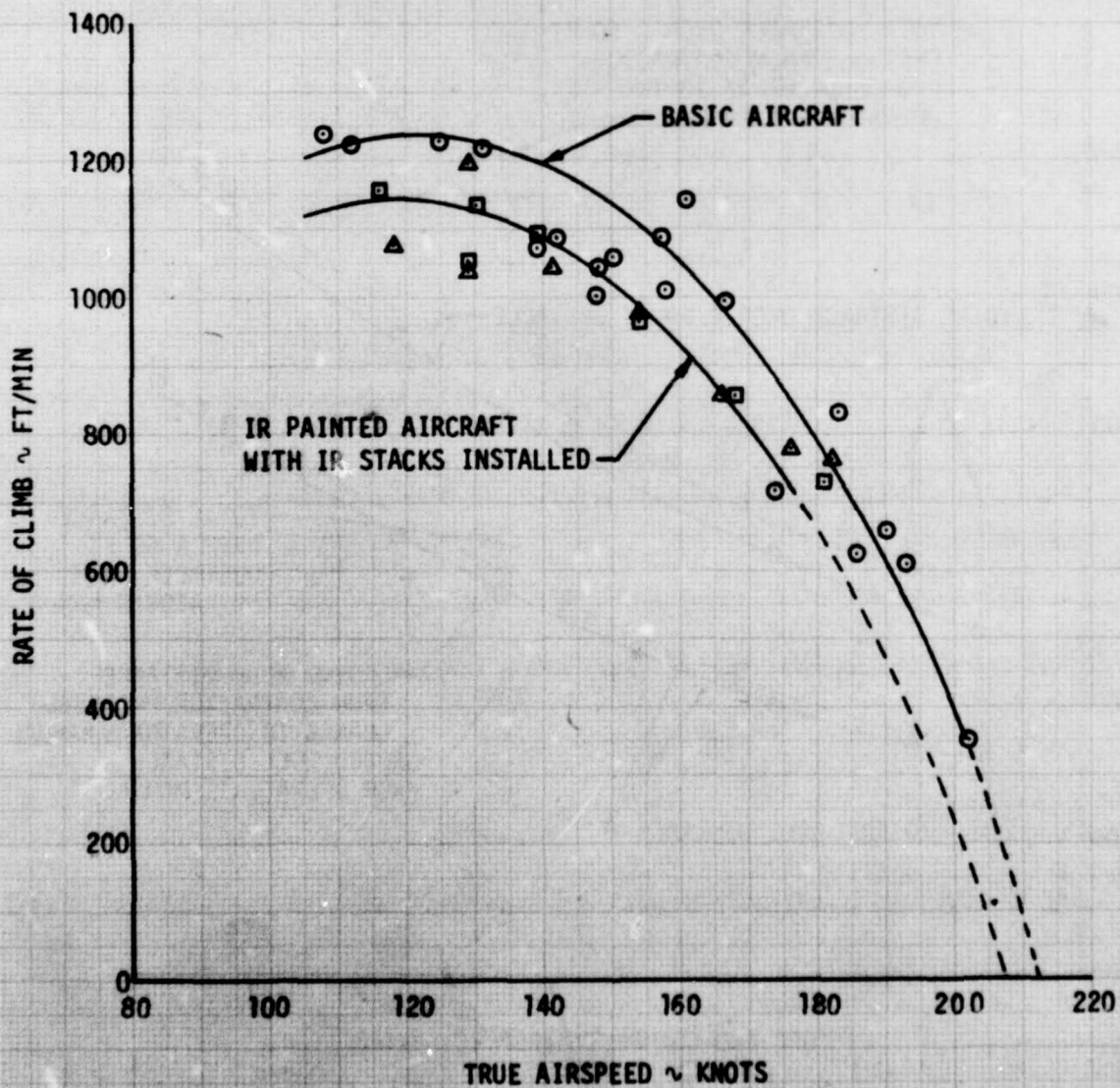

FIGURE 3
CALCULATED DUAL ENGINE CLIMB PERFORMANCE COMPARISON

AIRCRAFT = U-21A
GROSS WEIGHT = 9650 LB
10000 FT = STANDARD DAY
PROPELLER SPEED = 2000 RPM
CRUISE CONFIGURATION
BASED ON SPECIFICATION ENGINE NORMAL RATED CLIMB POWER

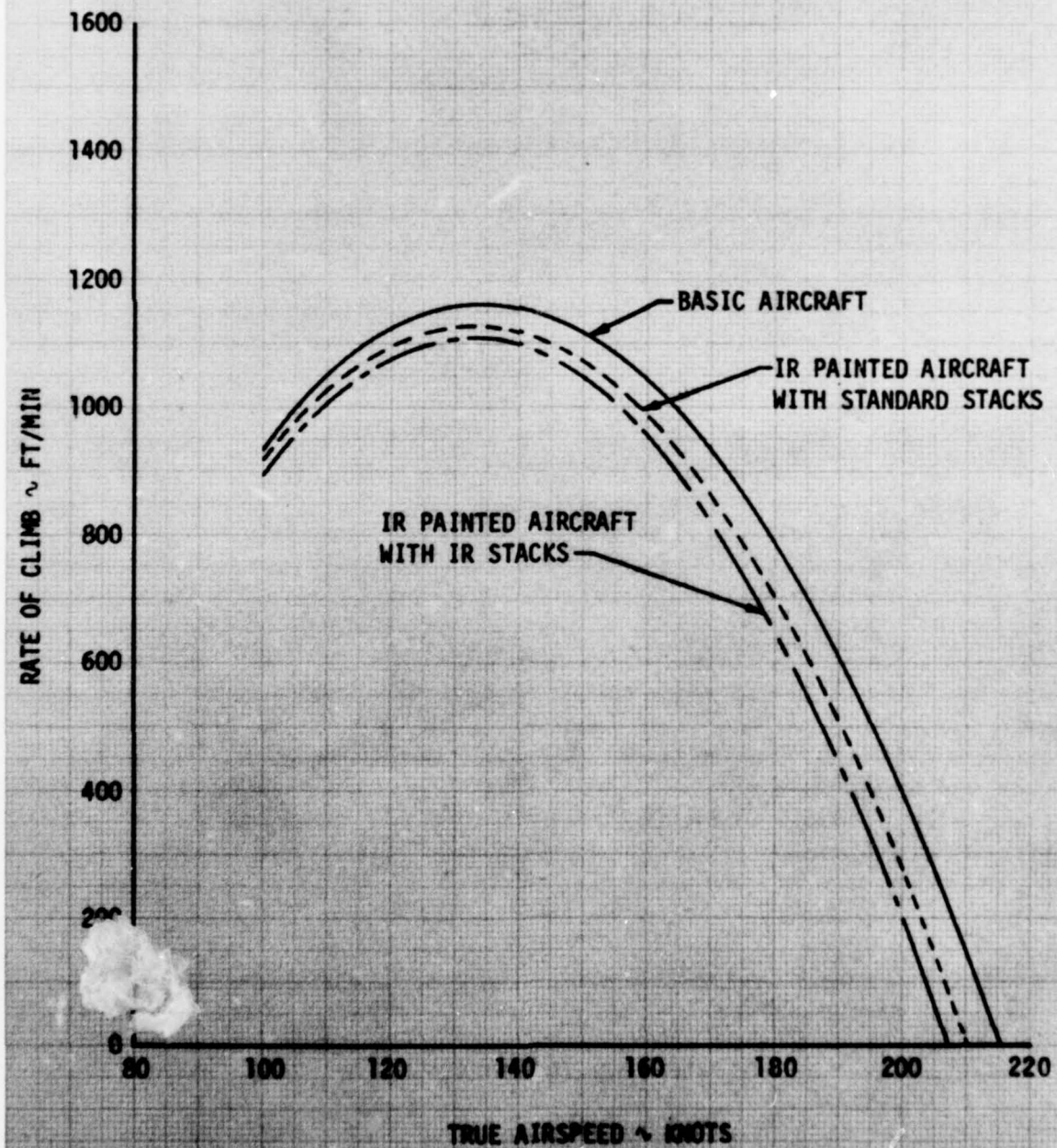

FIGURE 4
SINGLE ENGINE CLIMB PERFORMANCE
U-21A USA S/N 66-18008

- NOTES: 1. STANDARD DAY CONDITIONS = 5000 FT.
2. GROSS WEIGHT = 9650 POUNDS.
3. PROPELLER SPEED = 2000 RPM.
4. LEFT ENGINE OUT, PROPELLER FEATHERED.
5. ○ BASIC AIRCRAFT.
6. □ IR PAINTED AIRCRAFT WITH IR SUPPRESSORS.
7. NORMAL RATED CLIMB POWER (TEST ENGINE).
8. CRUISE CONFIGURATION.
9. POWER AVAILABLE FROM VACL ENGINE DECK #1518B.

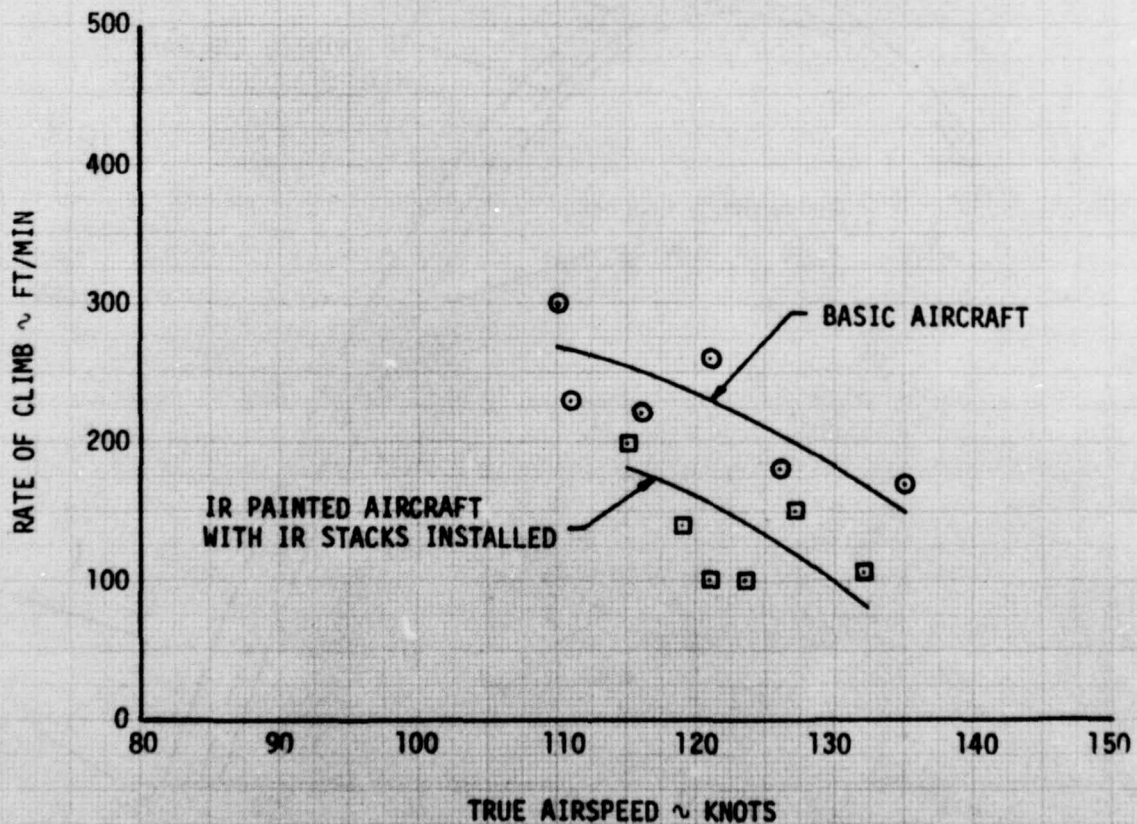

FIGURE 5
CALCULATED SINGLE ENGINE CLIMB PERFORMANCE COMPARISON

AIRCRAFT = U-21A
GROSS WEIGHT = 9650 LB
5000 FT = STANDARD DAY
PROPELLER SPEED = 2000 RPM
CRUISE CONFIGURATION
BASED ON SPECIFICATION ENGINE NORMAL RATED CLIMB POWER

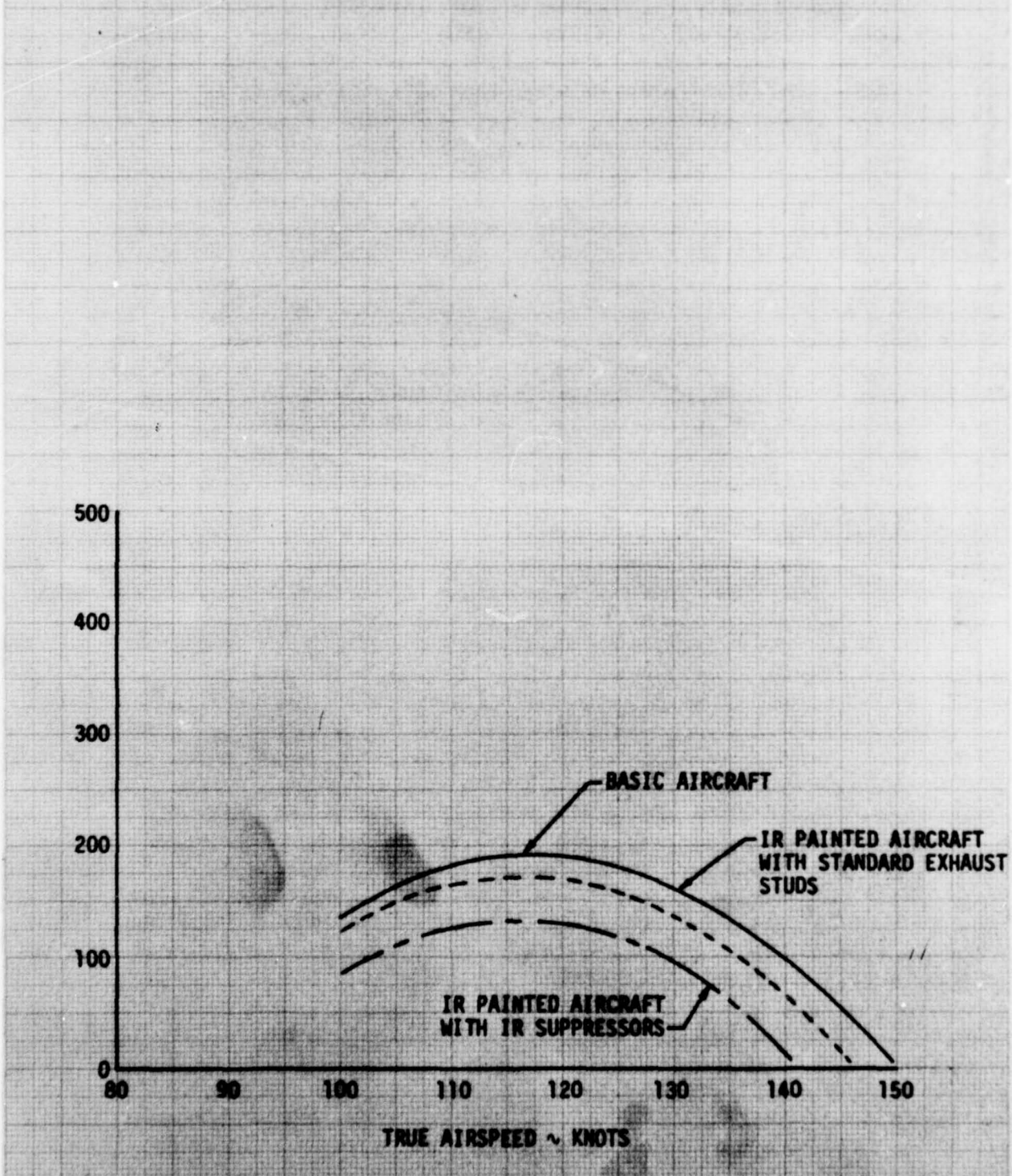
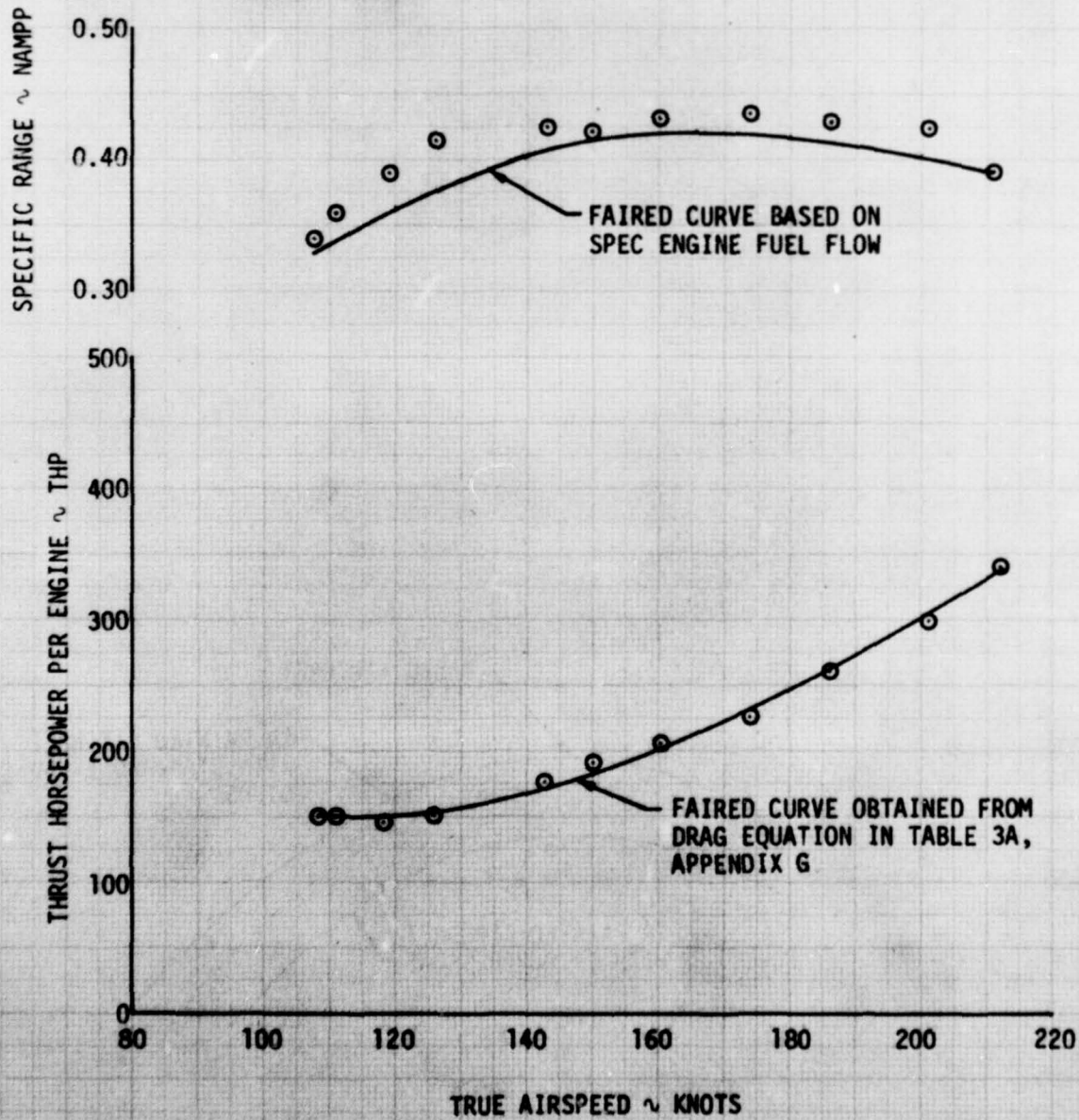

FIGURE 6
DUAL ENGINE LEVEL FLIGHT PERFORMANCE
U-21A USA S/N 66-18008
BASIC AIRCRAFT

| AVG GROSS WEIGHT ~LB | AVG LONG. CG ~FS | AVG DENSITY ALTITUDE ~FT | AVG OAT ~°C | PROPELLER SPEED ~RPM | CONFIGURATION |
|-------------------------|---------------------|-----------------------------|----------------|-------------------------|---------------|
| 9290 | 152.9(FWD) | 11930 | 12.0 | 1900 | CRUISE |

NOTE: NAMPP TEST POINTS OBTAINED FROM TEST FUEL FLOW DATA.



**FIGURE 7
DUAL ENGINE LEVEL FLIGHT PERFORMANCE
U-21A USA S/N 66-18008
IR PAINTED AIRCRAFT WITH IR SUPPRESSORS**

| AVG GROSS WEIGHT ~LB | AVG LONG. CG ~FS | AVG DENSITY ALTITUDE ~FT | AVG OAT ~°C | PROPELLER SPEED ~RPM | CONFIGURATION |
|-------------------------|---------------------|-----------------------------|----------------|-------------------------|---------------|
| 9280 | 152.8(FWD) | 10950 | 4.0 | 1900 | CRUISE |

NOTE: NAMPP TEST POINTS OBTAINED FROM TEST FUEL FLOW DATA.

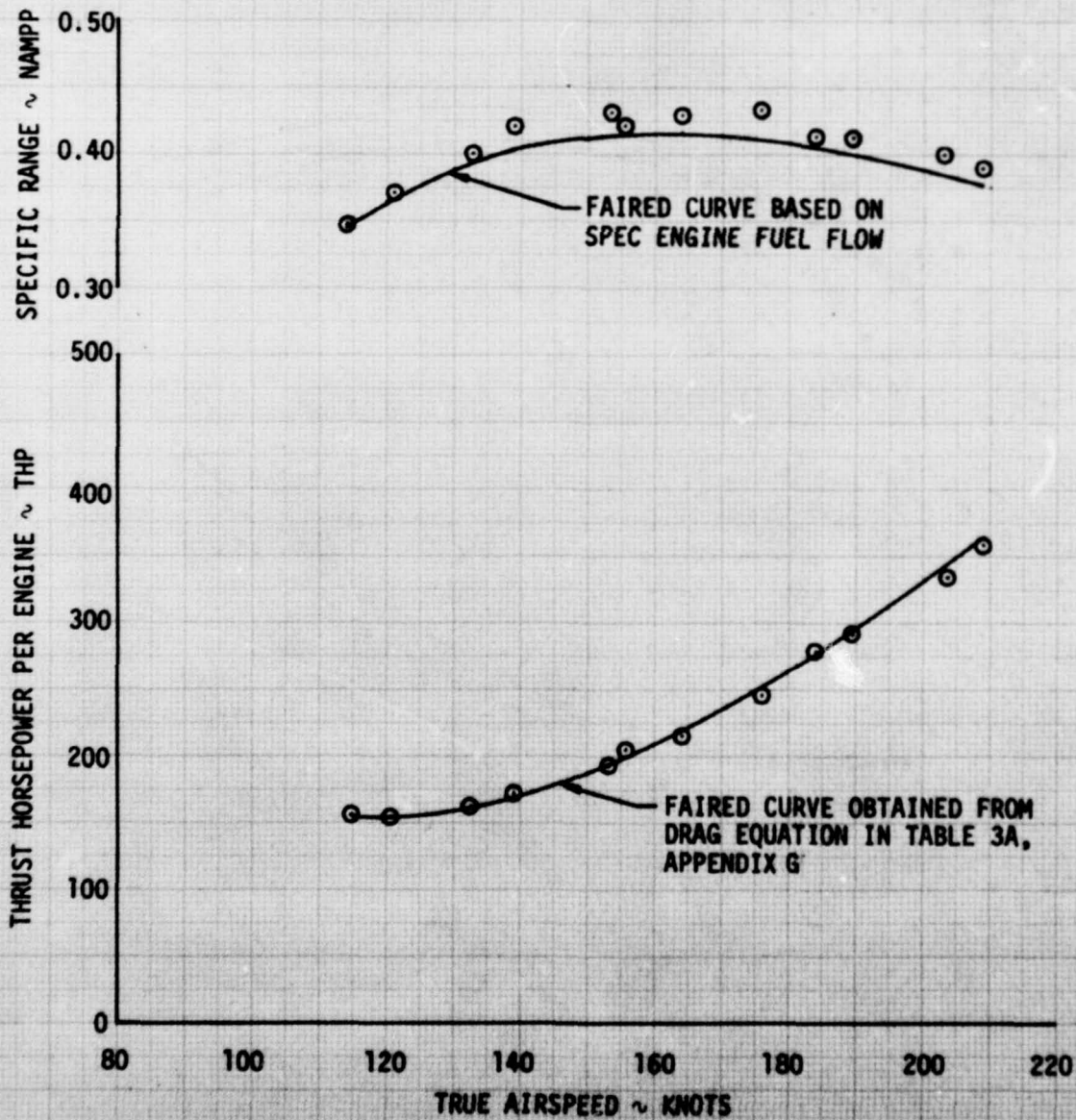

FIGURE 8
CALCULATED DUAL ENGINE LEVEL FLIGHT PERFORMANCE COMPARISON

AIRCRAFT = U21A
GROSS WEIGHT = 9650 LB
10000 FT - STANDARD DAY
PROPELLER SPEED = 1900 RPM
CRUISE CONFIGURATION
SOLID LINE = BASIC AIRCRAFT
SHORT DASH = PAINTED AIRCRAFT WITH STANDARD STACKS
DOT-DASH = PAINTED AIRCRAFT WITH IR STACKS
SPECIFIC RANGE FAIRINGS FROM SPEC ENGINE FUEL FLOW
THRUST HORSEPOWER FAIRINGS FROM EQUATIONS IN TABLE 3a-3c, APP G

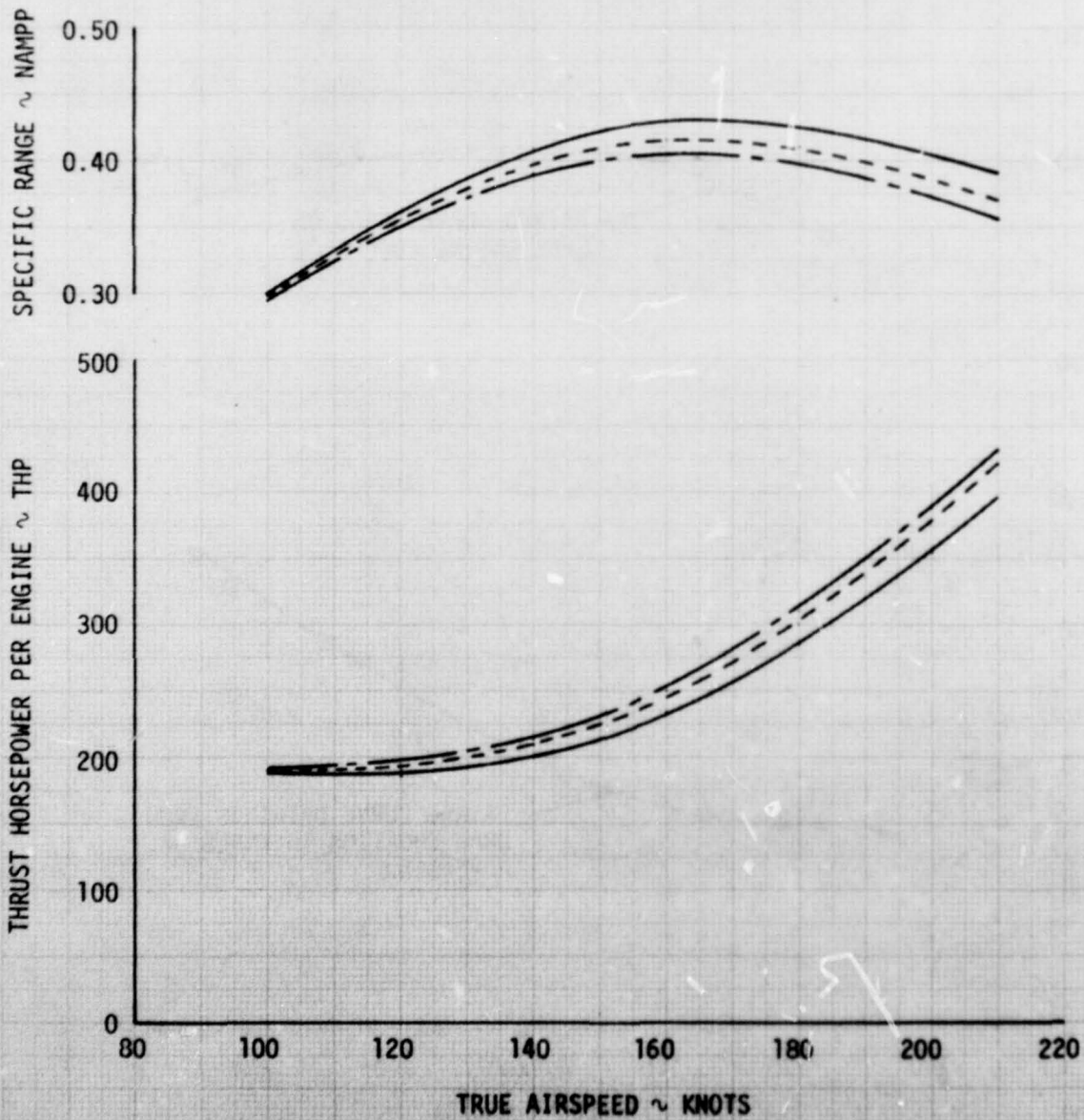

FIGURE 9
 SINGLE ENGINE LEVEL FLIGHT PERFORMANCE
 U-21A USA S/N 66-18008
 BASIC AIRCRAFT

| AVG GROSS WEIGHT ~LB | AVG LONG CG ~FS | AVG DENSITY ALTITUDE ~FT | AVG OAT ~°C | AVG PROPELLER SPEED ~RPM | CONFIGURATION |
|-------------------------|--------------------|-----------------------------|----------------|-----------------------------|---------------|
| 9210 | 152.7 (FWD) | 9110 | 19.0 | 1900 | CRUISE |

NOTE: 1. NAMPP TEST POINTS OBTAINED FROM TEST FUEL FLOW DATA
 2. LEFT ENGINE INOPERATIVE AND PROPELLER FEATHERED

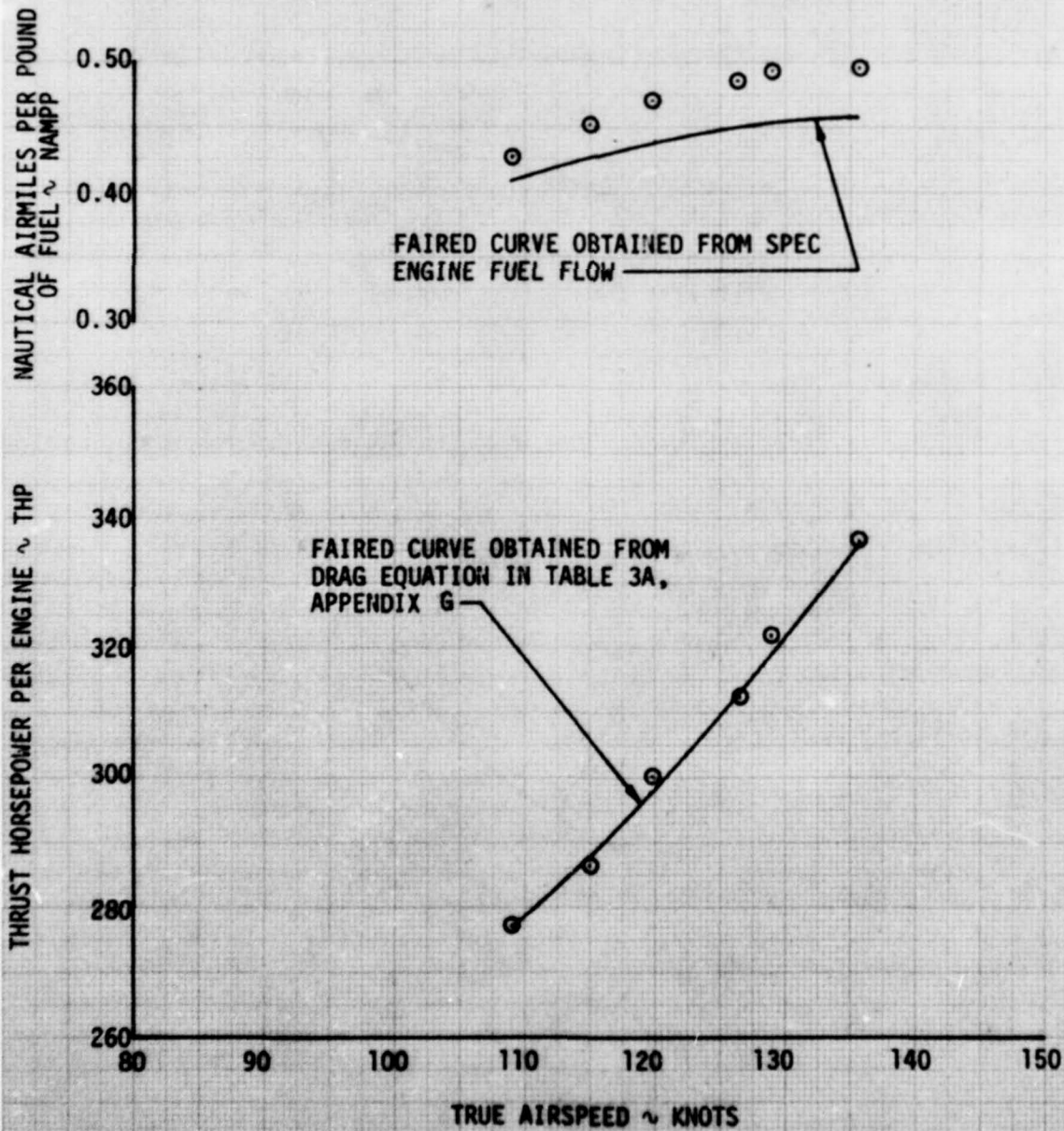

FIGURE 10
 SINGLE ENGINE LEVEL FLIGHT PERFORMANCE
 U21A USA S/N 66-18008
 IR PAINTED AIRCRAFT WITH IR STACKS

| AVG GROSS WEIGHT ~LB | AVG LONG CG ~FS | AVG DENSITY ALTITUDE ~FT | AVG OAT ~°C | AVG PROPELLER SPEED ~RPM | CONFIGURATION |
|-------------------------|--------------------|-----------------------------|----------------|-----------------------------|---------------|
| 9830 | 153.0 (FWD) | 8360 | 14.0 | 1900 | CRUISE |

NOTE: 1. NAMPP TEST POINTS OBTAINED FROM TEST FUEL FLOW DATA
 2. LEFT ENGINE INOPERATIVE AND PROPELLER FEATHERED

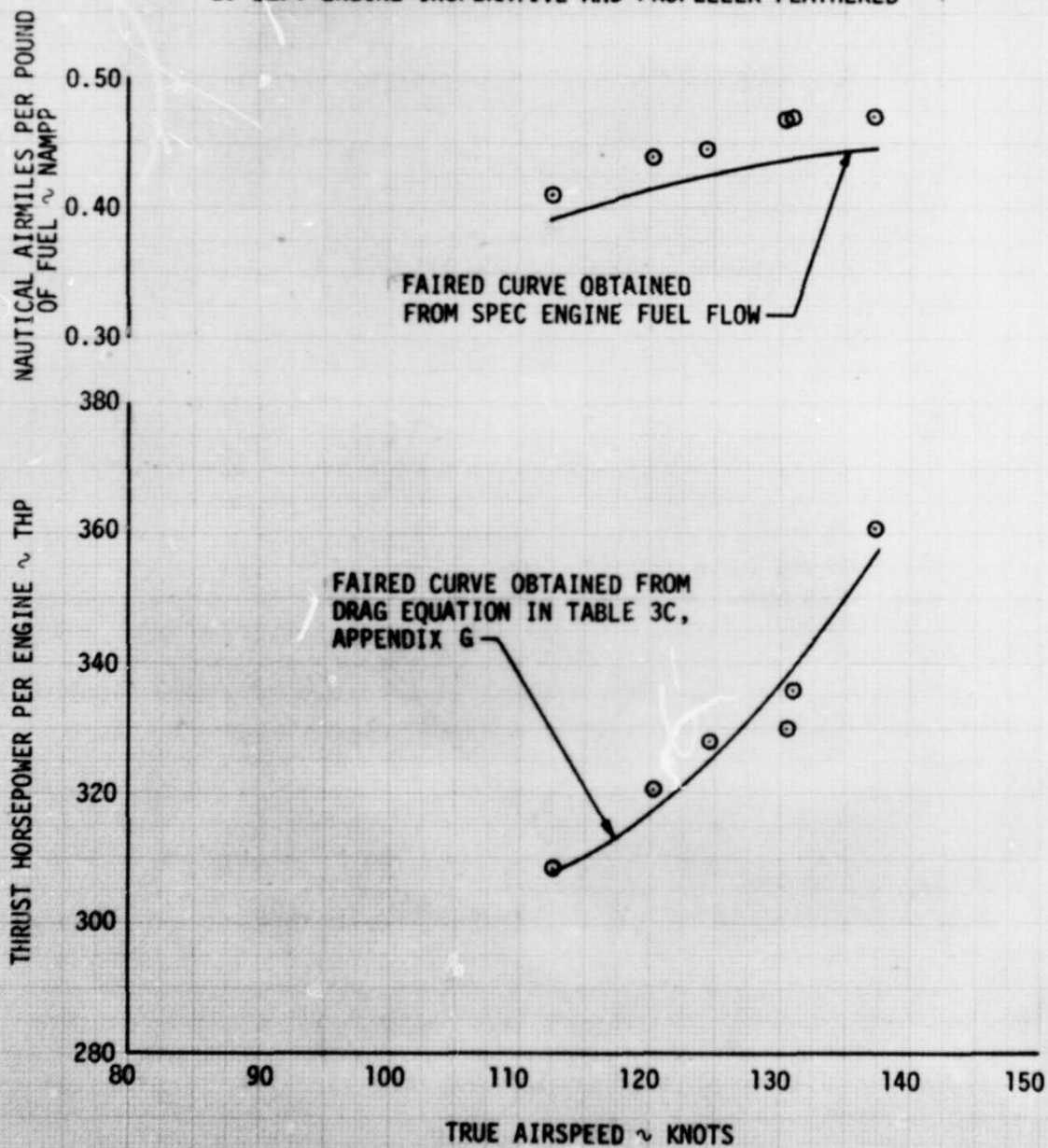

FIGURE 11
 CALCULATED SINGLE ENGINE LEVEL FLIGHT PERFORMANCE COMPARISON

AIRCRAFT = U-21A
 GROSS WEIGHT = 9650 LB
 10000 FT - STANDARD DAY
 PROPELLER SPEED = 1900 RPM
 CRUISE CONFIGURATION
 SOLID LINE = BASIC AIRCRAFT
 SHORT DASH = PAINTED AIRCRAFT WITH STANDARD STACKS
 DOT-DASH = PAINTED AIRCRAFT WITH IR STACKS
 SPECIFIC RANGE FAIRINGS FROM UAEL ENGINE DECK
 THRUST HORSEPOWER FAIRINGS FROM EQUATIONS IN TABLE 3a-3c, APP G

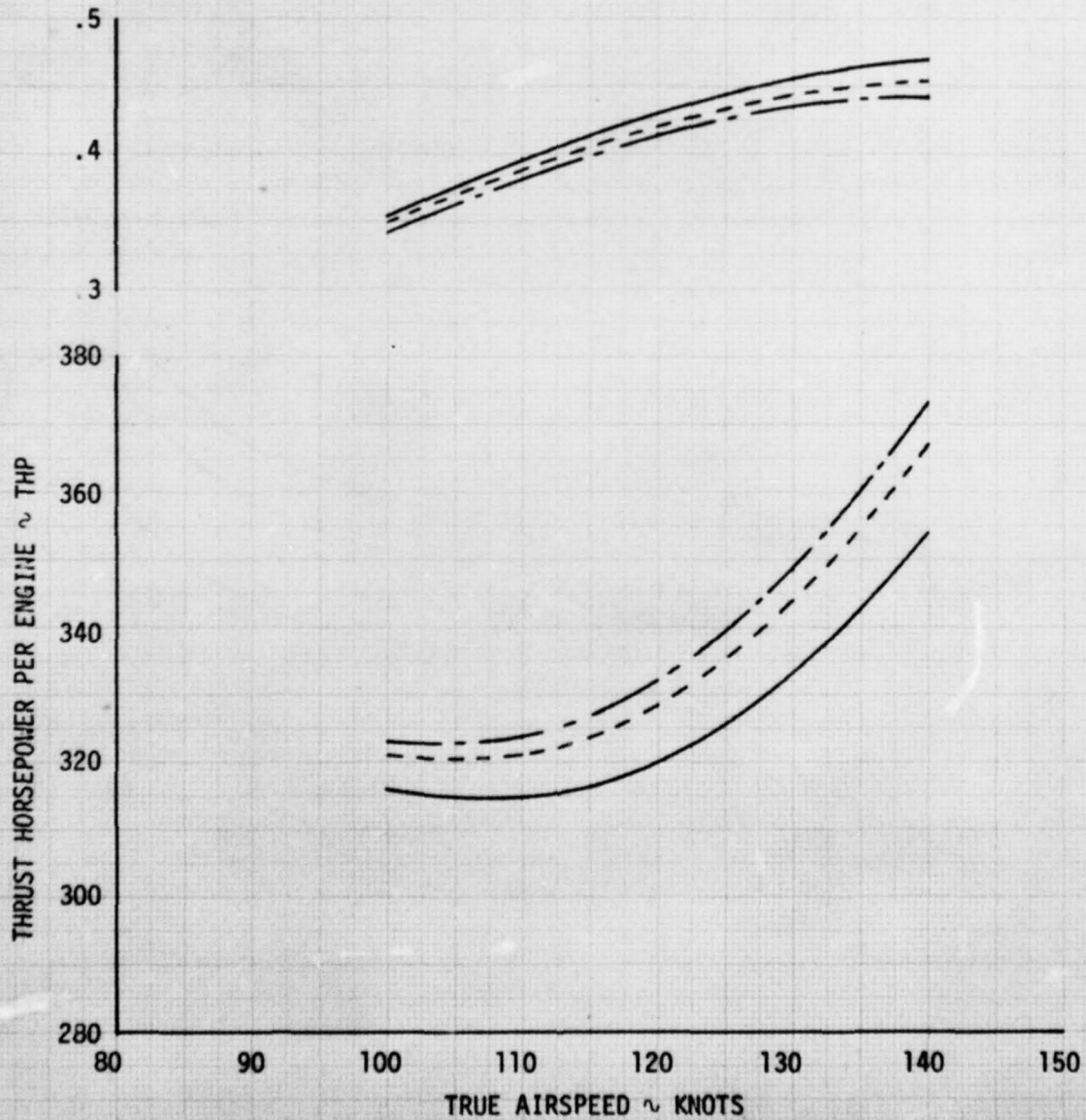

FIGURE 12
 STALL AIRSPEED VARIATION
 U-21A USA S/N 66-18008
 BASIC AIRCRAFT

- CRUISE CONFIGURATION
- △ POWER APPROACH CONFIGURATION
- LANDING CONFIGURATION

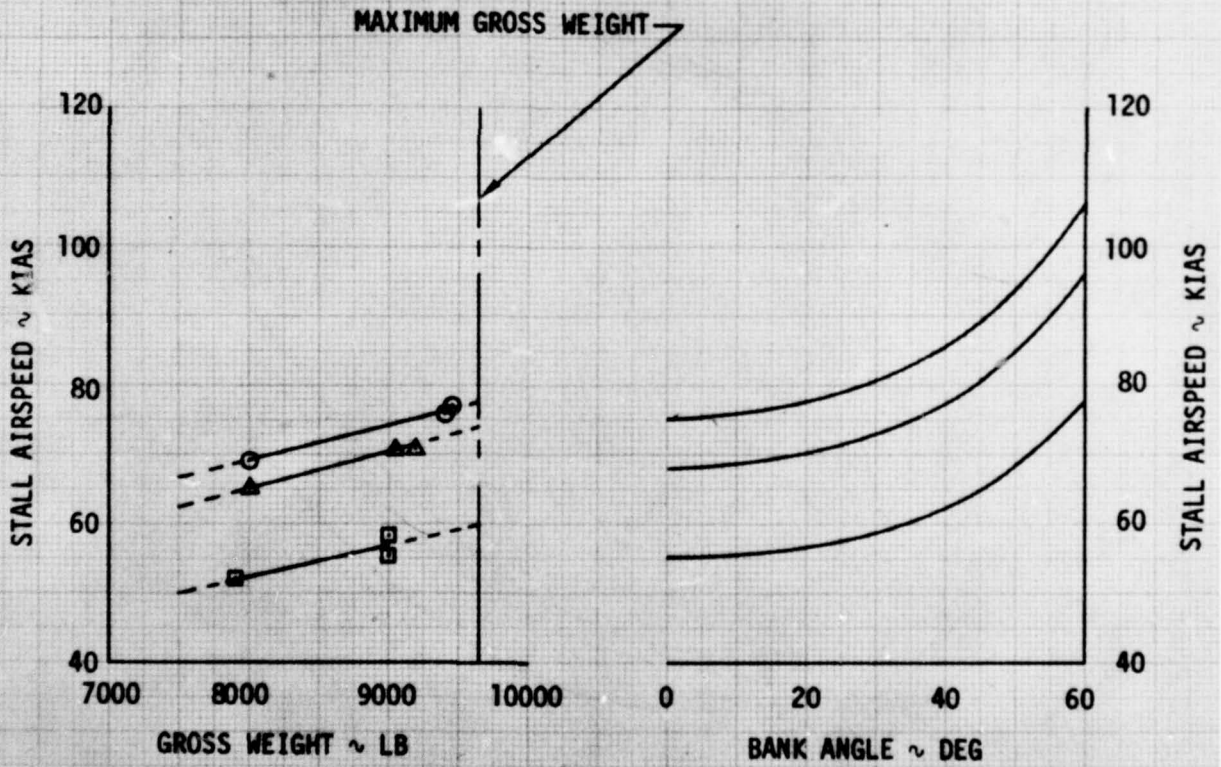

FIGURE 13
 STALL AIRSPEED VARIATION
 U-21A USA S/N 66-18008
 IR PAINTED AIRCRAFT WITH STANDARD EXHAUST STUBS

- CRUISE CONFIGURATION
- △ POWER APPROACH CONFIGURATION
- LANDING CONFIGURATION

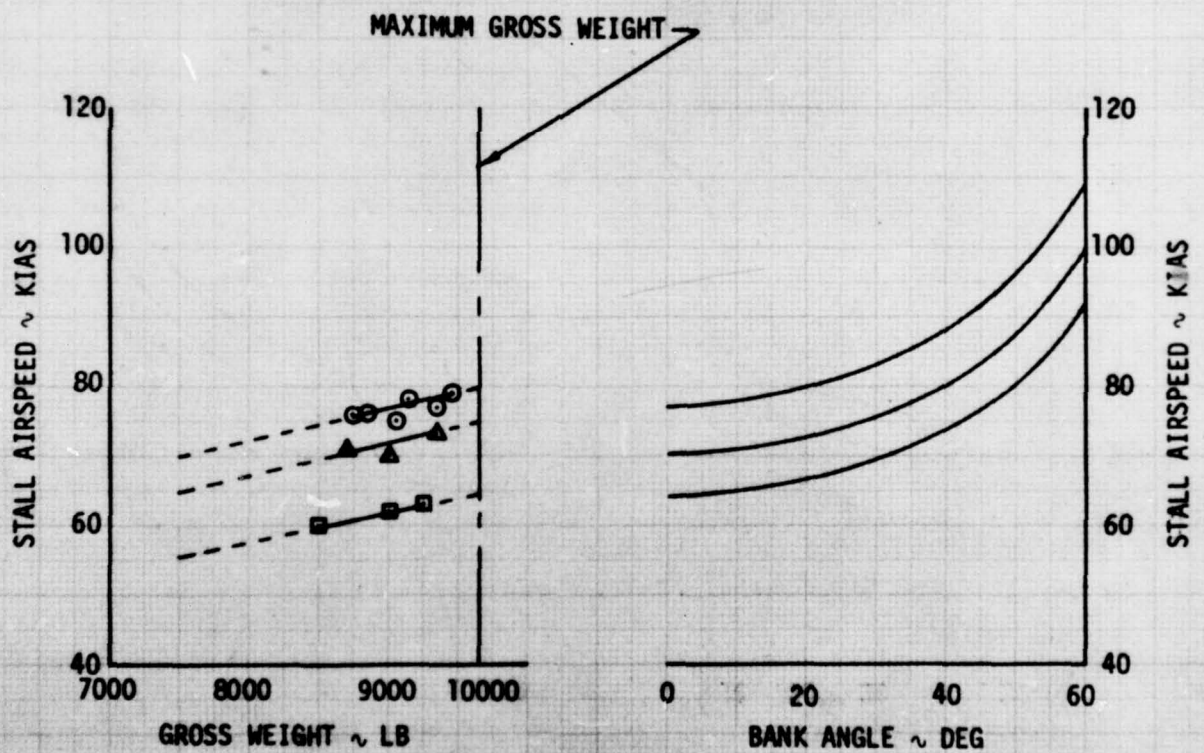

FIGURE 14
 STALL AIRSPEED VARIATION
 U-21A USA S/N 66-18008
 IR PAINTED AIRCRAFT WITH IR SUPPRESSORS

- CRUISE CONFIGURATION
- △ POWER APPROACH CONFIGURATION
- LANDING CONFIGURATION

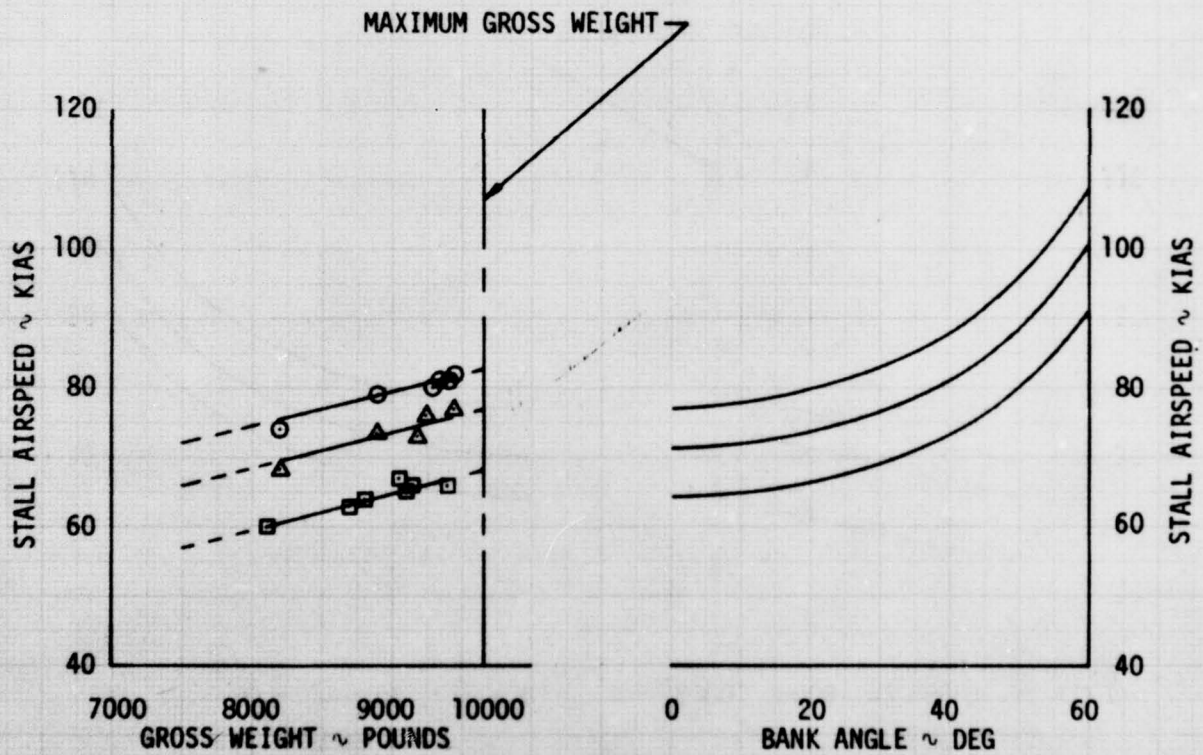

FIGURE 15
CONTROL POSITIONS IN TRIMMED FORWARD FLIGHT
 U-21A USA S/N 66-18008
 BASIC AIRCRAFT

| AVG GROSS WEIGHT ~ LB | AVG LONG CG LOCATION ~ FS | AVG DENSITY ALTITUDE ~ FT | AVG OAT ~ °C | PROPELLER SPEED ~ RPM | CONFIGURATION | FLIGHT CONDITION |
|--------------------------|------------------------------|------------------------------|-----------------|--------------------------|---------------|------------------|
| 9290 | 152.9 (FWD) | 11930 | 12.0 | 1900 | CRUISE | LEVEL FLIGHT |

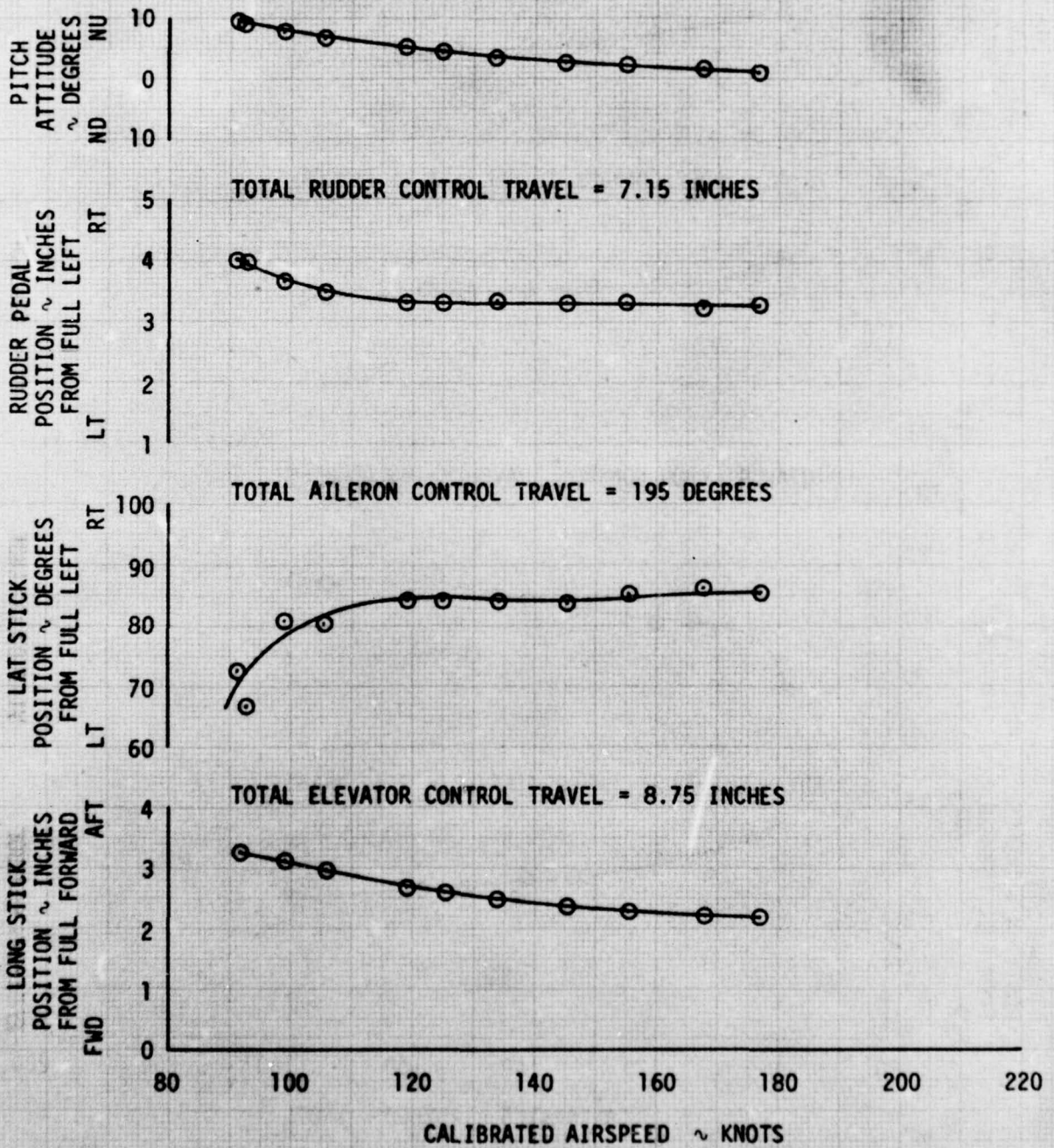

FIGURE 16
CONTROL POSITIONS IN TRIMMED FORWARD FLIGHT
U-21A USA S/N 66-18008
IR PAINTED AIRCRAFT WITH IR SUPPRESSORS

| AVG GROSS WEIGHT ~ LB | AVG LONG CG LOCATION ~ FS | AVG DENSITY ALTITUDE ~ FT | AVG OAT ~ °C | PROPELLER SPEED ~ RPM | CONFIGURATION | FLIGHT CONDITION |
|--------------------------|------------------------------|------------------------------|-----------------|--------------------------|---------------|------------------|
| 9280 | 152.8 (FWD) | 10950 | 4.0 | 1900 | CRUISE | LEVEL FLIGHT |

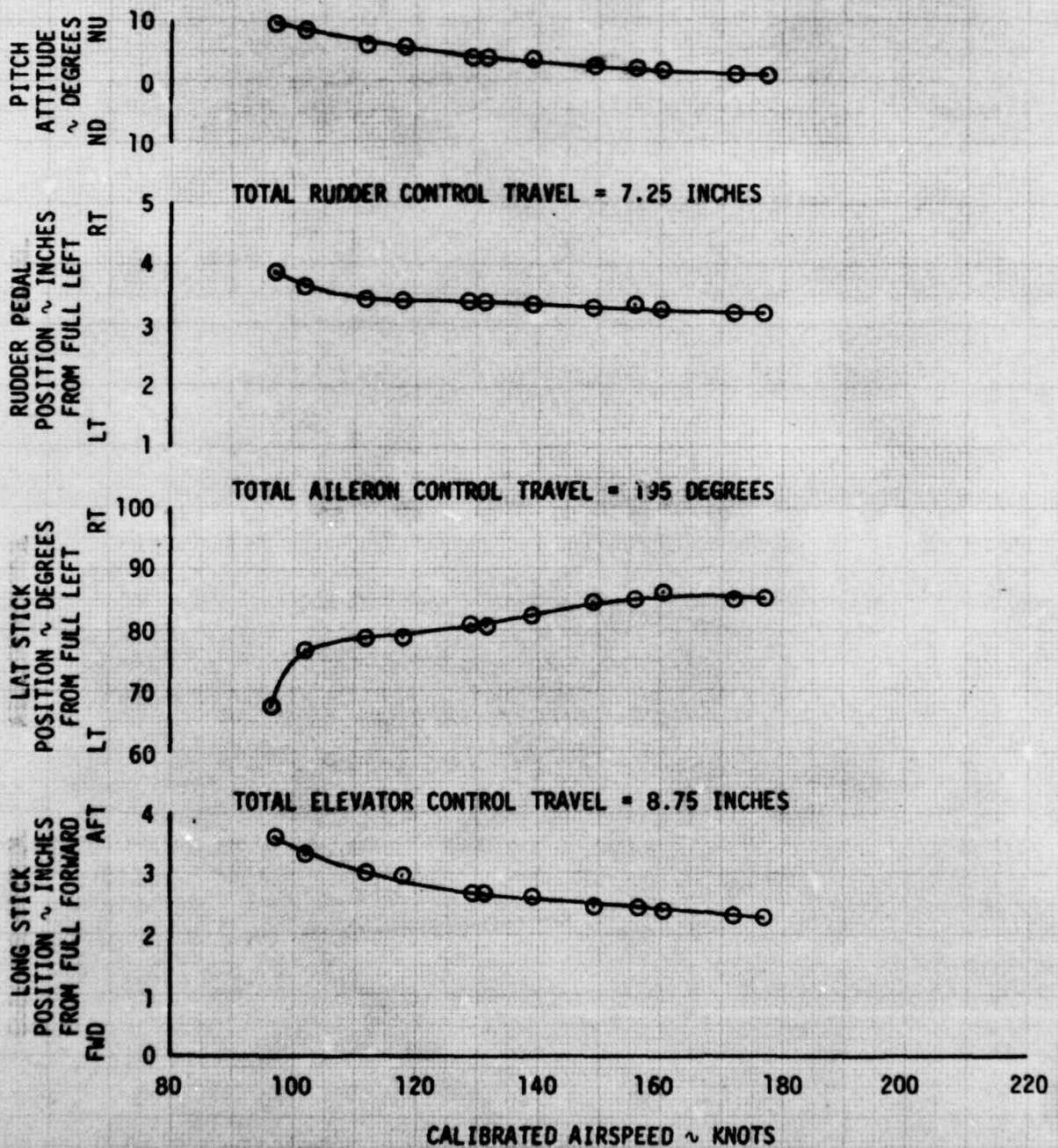

FIGURE 17
STATIC LONGITUDINAL STABILITY
U-21A USA S/N 66-18008
BASIC AIRCRAFT

| SYM | AVG GROSS WEIGHT ~ LB | AVG LONG CG LOCATION ~ FS | AVG DENSITY ALTITUDE ~ FT | AVG OAT ~ °C | PROPELLER SPEED ~ RPM | CONFIGURATION | FLIGHT CONDITION |
|-----|--------------------------|------------------------------|------------------------------|-----------------|--------------------------|----------------|------------------|
| ○ | 9150 | 159.4 (AFT) | 12100 | 11.0 | 2000 | POWER APPROACH | LEVEL FLIGHT |
| □ | 9320 | 159.7 (AFT) | 11730 | 12.5 | 1900 | CRUISE | LEVEL FLIGHT |
| △ | 9490 | 160.0 (AFT) | 11770 | 12.0 | 1900 | CRUISE | LEVEL FLIGHT |

NOTE: SHADED SYMBOLS DENOTE TRIM

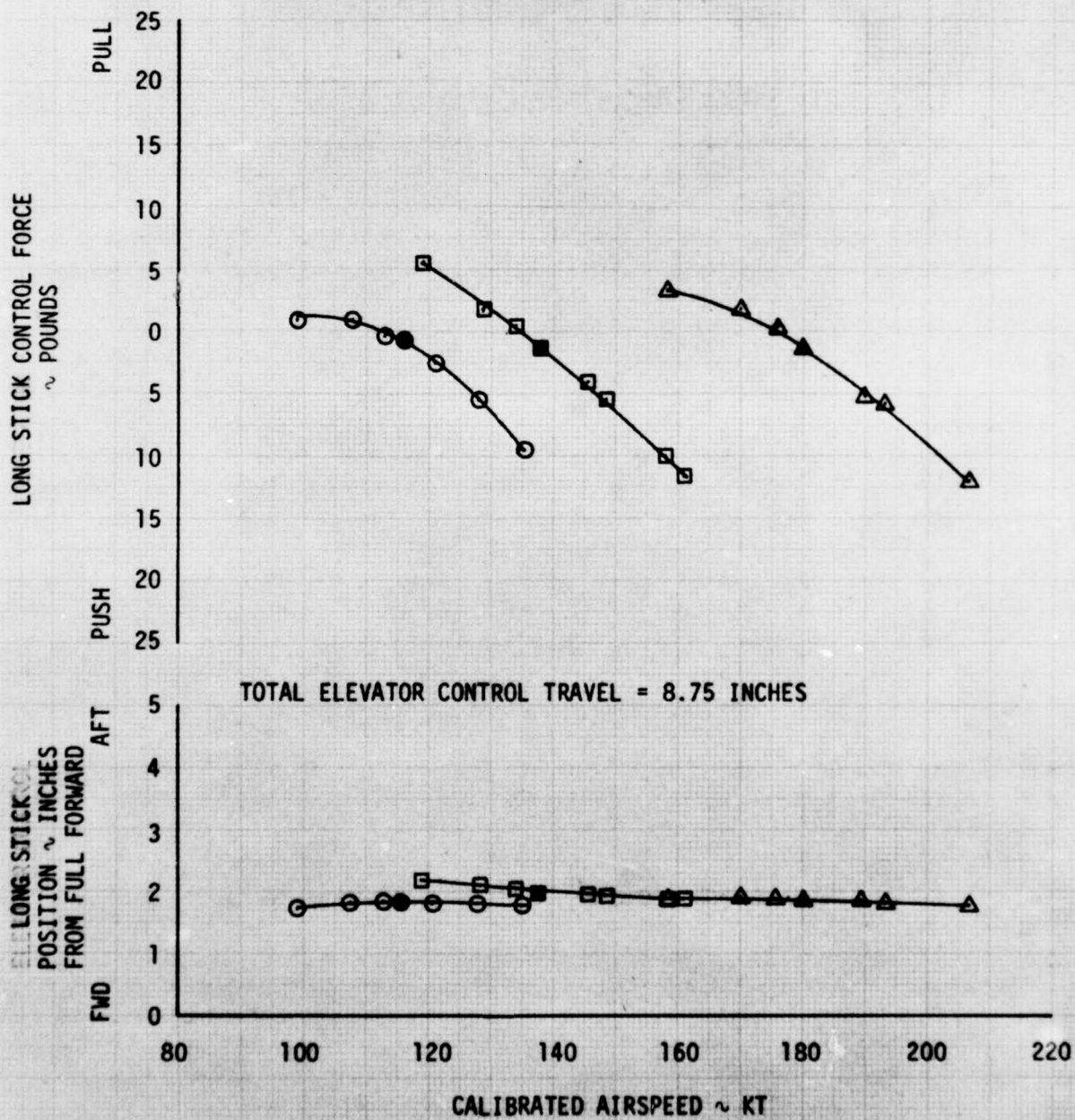

FIGURE 18
 STATIC LONGITUDINAL STABILITY
 U-21A USA S/N 66-18008
 IR PAINTED AIRCRAFT WITH IR SUPPRESSORS

| SYM | AVG GROSS WEIGHT ~ LB | AVG LONG CG LOCATION ~ FS | AVG DENSITY ALTITUDE ~ FT | AVG OAT ~ °C | PROPELLER SPEED ~ RPM | CONFIGURATION | FLIGHT CONDITION |
|-----|--------------------------|------------------------------|------------------------------|-----------------|--------------------------|----------------|------------------|
| ○ | 9010 | 159.2 (AFT) | 11330 | 6.0 | 2000 | POWER APPROACH | LEVEL FLIGHT |
| □ | 9200 | 159.5 (AFT) | 10880 | 7.4 | 1900 | CRUISE | LEVEL FLIGHT |
| △ | 8540 | 158.3 (AFT) | 11100 | 6.3 | 1900 | CRUISE | LEVEL FLIGHT |

NOTE: SHADED SYMBOLS DENOTE TRIM

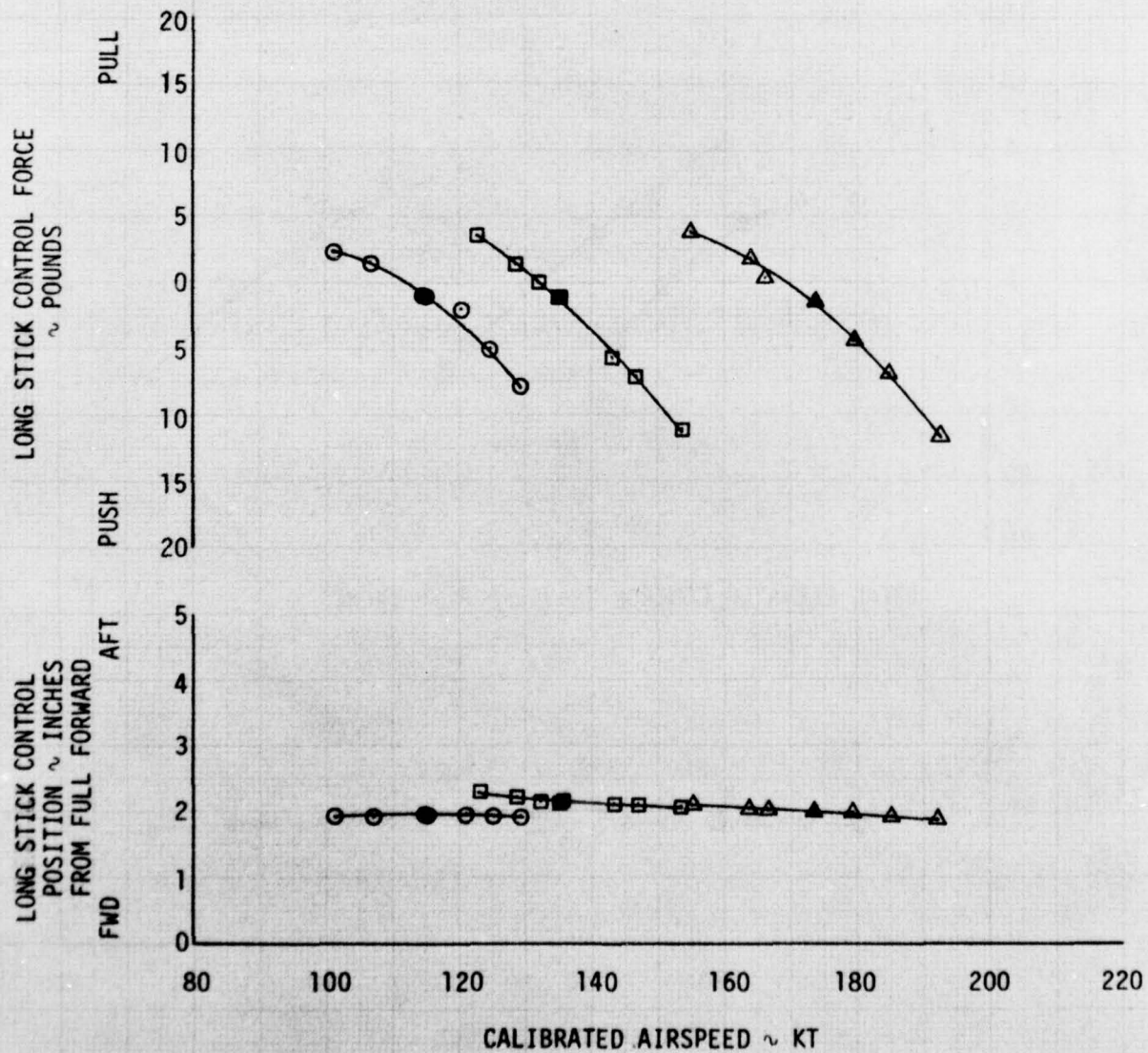

FIGURE 19
STATIC LATERAL-DIRECTIONAL STABILITY
U-21A USA S/N 66-18008
BASIC AIRCRAFT

| AVG GROSS WEIGHT ~ LB | AVG LONG CG LOCATION ~ FS | AVG DENSITY ALTITUDE ~ FT | AVG OAT ~ °C | TRIM AIRSPEED ~ KCAS | PROPELLER SPEED ~ RPM | CONFIGURATION | FLIGHT CONDITION |
|--------------------------|------------------------------|------------------------------|-----------------|-------------------------|--------------------------|----------------|------------------|
| 9050 | 159.2 (AFT) | 11890 | 11.5 | 116 | 2000 | POWER APPROACH | LEVEL FLIGHT |

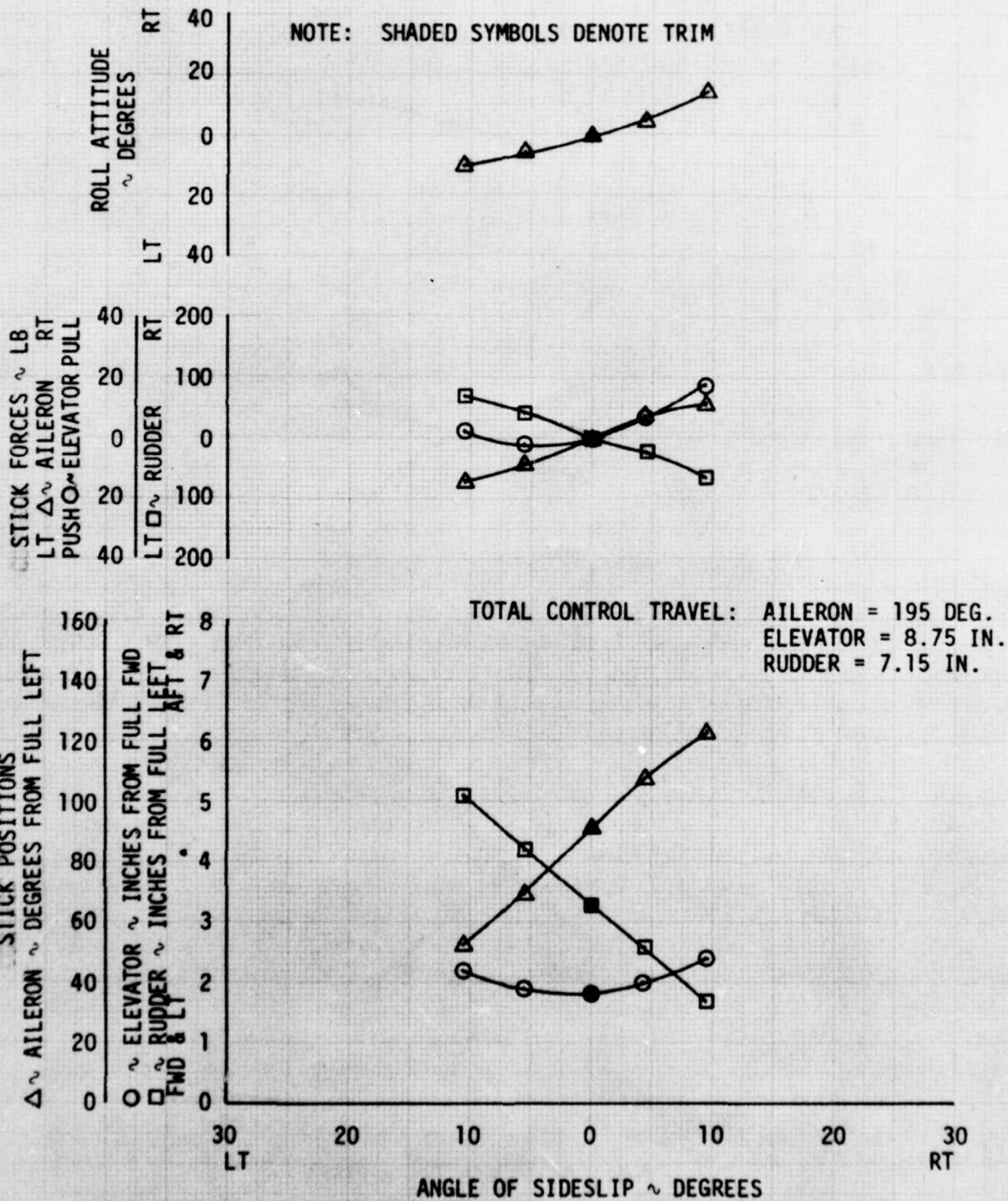

FIGURE 20
STATIC LATERAL-DIRECTIONAL STABILITY
U-21A USA S/N 66-18008
IR PAINTED AIRCRAFT WITH STACKS

| AVG GROSS WEIGHT ~ LB | AVG LONG CG LOCATION ~ FS | AVG DENSITY ALTITUDE ~ FT | AVG OAT ~ °C | TRIM AIRSPEED ~ KCAS | PROPELLER SPEED ~ RPM | CONFIGURATION | FLIGHT CONDITION |
|--------------------------|------------------------------|------------------------------|-----------------|-------------------------|--------------------------|----------------|------------------|
| 8830 | 158.8 (AFT) | 11030 | 7.0 | 112 | 2000 | POWER APPROACH | LEVEL FLIGHT |

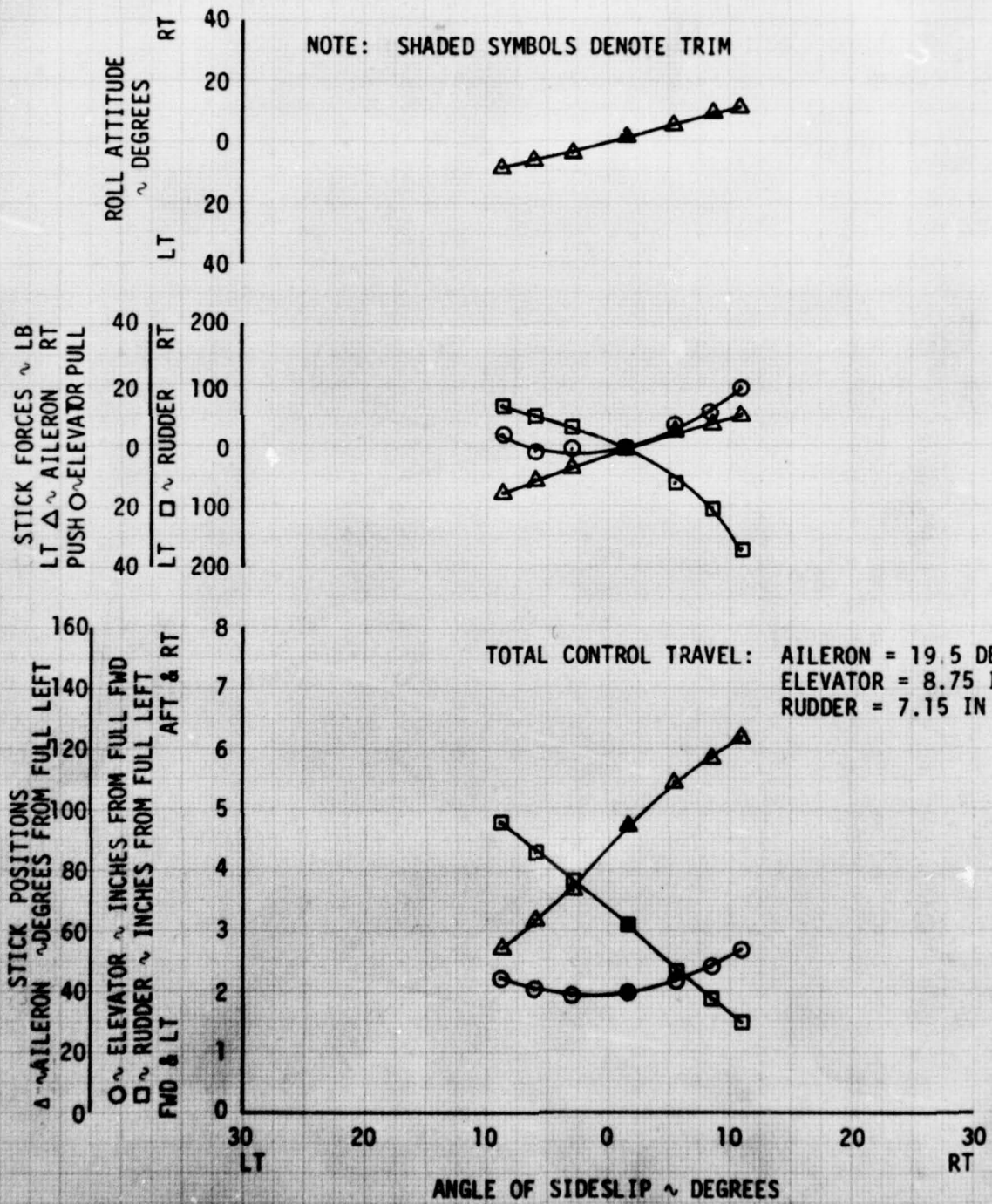

FIGURE 21
STATIC LATERAL-DIRECTIONAL STABILITY
U-21A USA S/N 66-18008
BASIC AIRCRAFT

| AVG GROSS WEIGHT ~ LB | AVG LONG CG LOCATION ~ FS | AVG DENSITY ALTITUDE ~ FT | AVG OAT ~ °C | TRIM AIRSPEED ~ KCAS | PROPELLER SPEED ~ RPM | CONFIGURATION | FLIGHT CONDITION |
|--------------------------|------------------------------|------------------------------|-----------------|-------------------------|--------------------------|---------------|------------------|
| 8930 | 159.0 (AFT) | 11640 | 12.0 | 143 | 1900 | CRUISE | LEVEL FLIGHT |

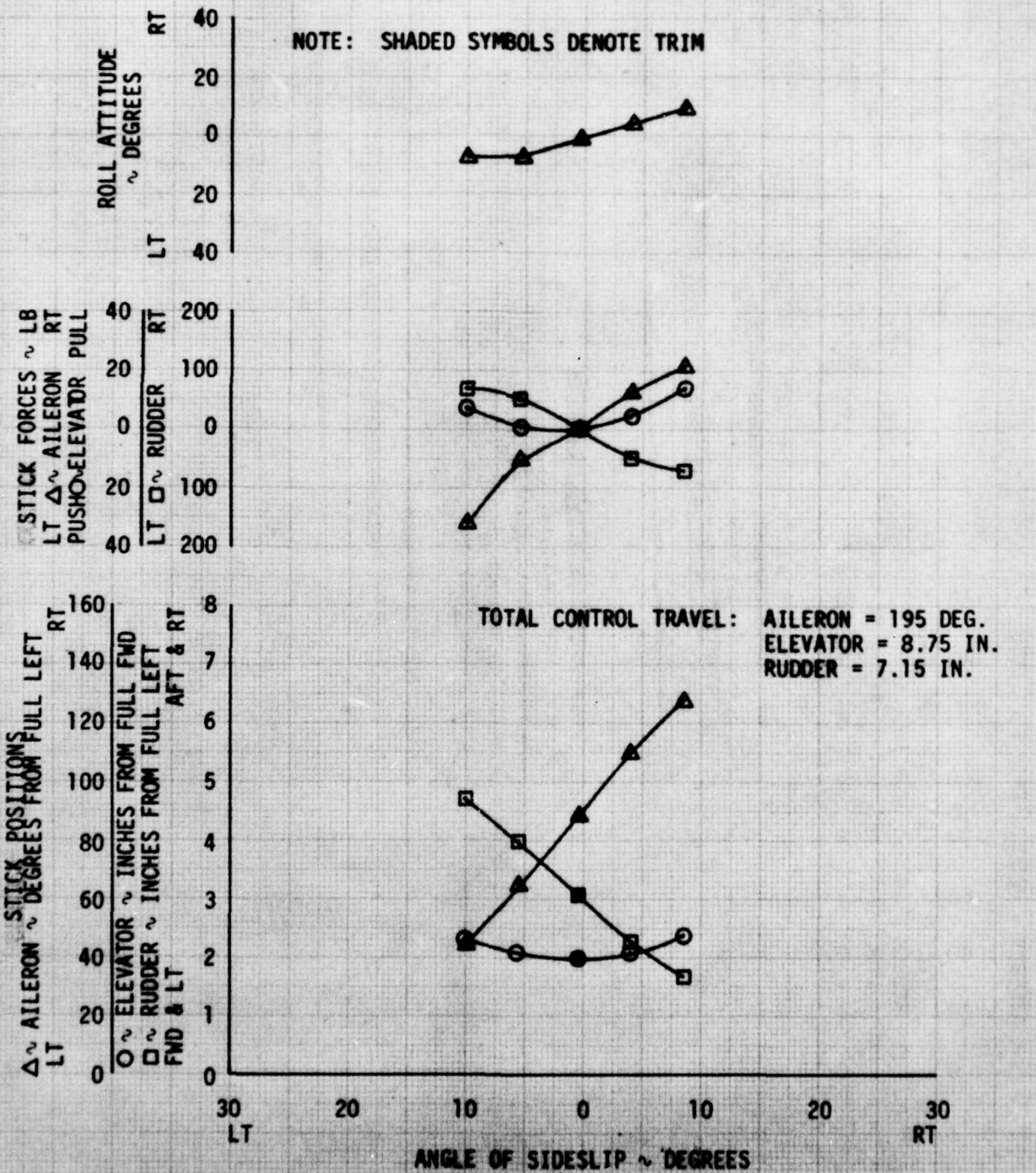

FIGURE 22
STATIC LATERAL-DIRECTIONAL STABILITY
U-21A USA S/N 66-18008
IR PAINTED AIRCRAFT WITH IR SUPPRESSORS

| AVG GROSS WEIGHT | AVG LONG CG LOCATION | AVG DENSITY ALTITUDE | AVG OAT | TRIM AIRSPEED | PROPELLER SPEED | CONFIGURATION | FLIGHT CONDITION |
|------------------|----------------------|----------------------|---------|---------------|-----------------|---------------|------------------|
| ~ LB | ~ FS | ~ FT | ~ °C | ~ KCAS | ~ RPM | | |
| 8670 | 158.5 (AFT) | 10770 | 7.5 | 136 | 1900 | CRUISE | LEVEL FLIGHT |

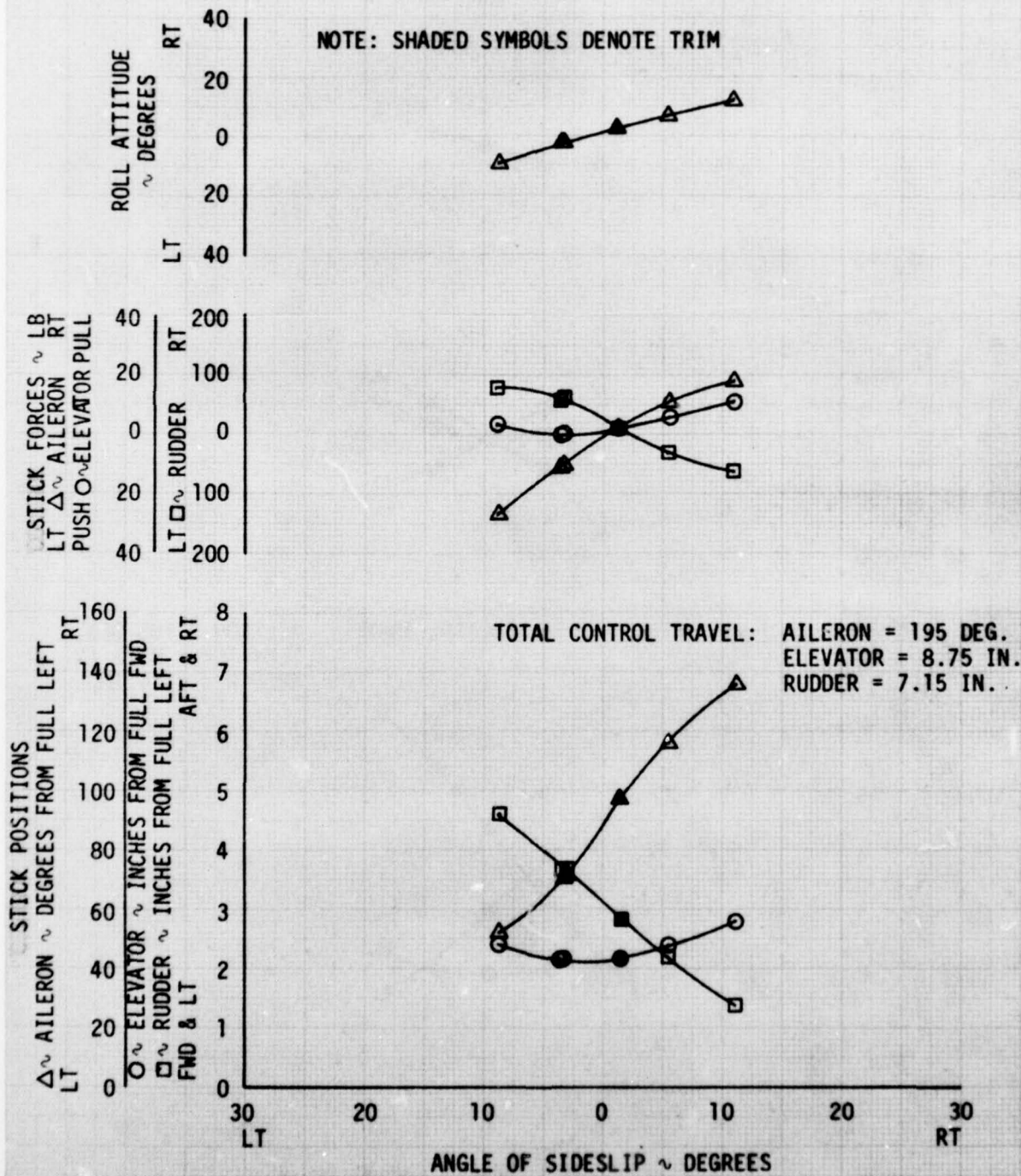

FIGURE 23
STATIC LATERAL-DIRECTIONAL STABILITY
U-21A USA S/N 66-18008
BASIC AIRCRAFT

| AVG GROSS WEIGHT ~ LB | AVG LONG CG LOCATION ~ FS | AVG DENSITY ALTITUDE ~ FT | AVG OAT ~ °C | TRIM AIRSPEED ~ KCAS | PROPELLER SPEED ~ RPM | CONFIGURATION | FLIGHT CONDITION |
|--------------------------|------------------------------|------------------------------|-----------------|-------------------------|--------------------------|---------------|------------------|
| 8790 | 158.8 (AFT) | 11800 | 11.0 | 184 | 1900 | CRUISE | LEVEL FLIGHT |

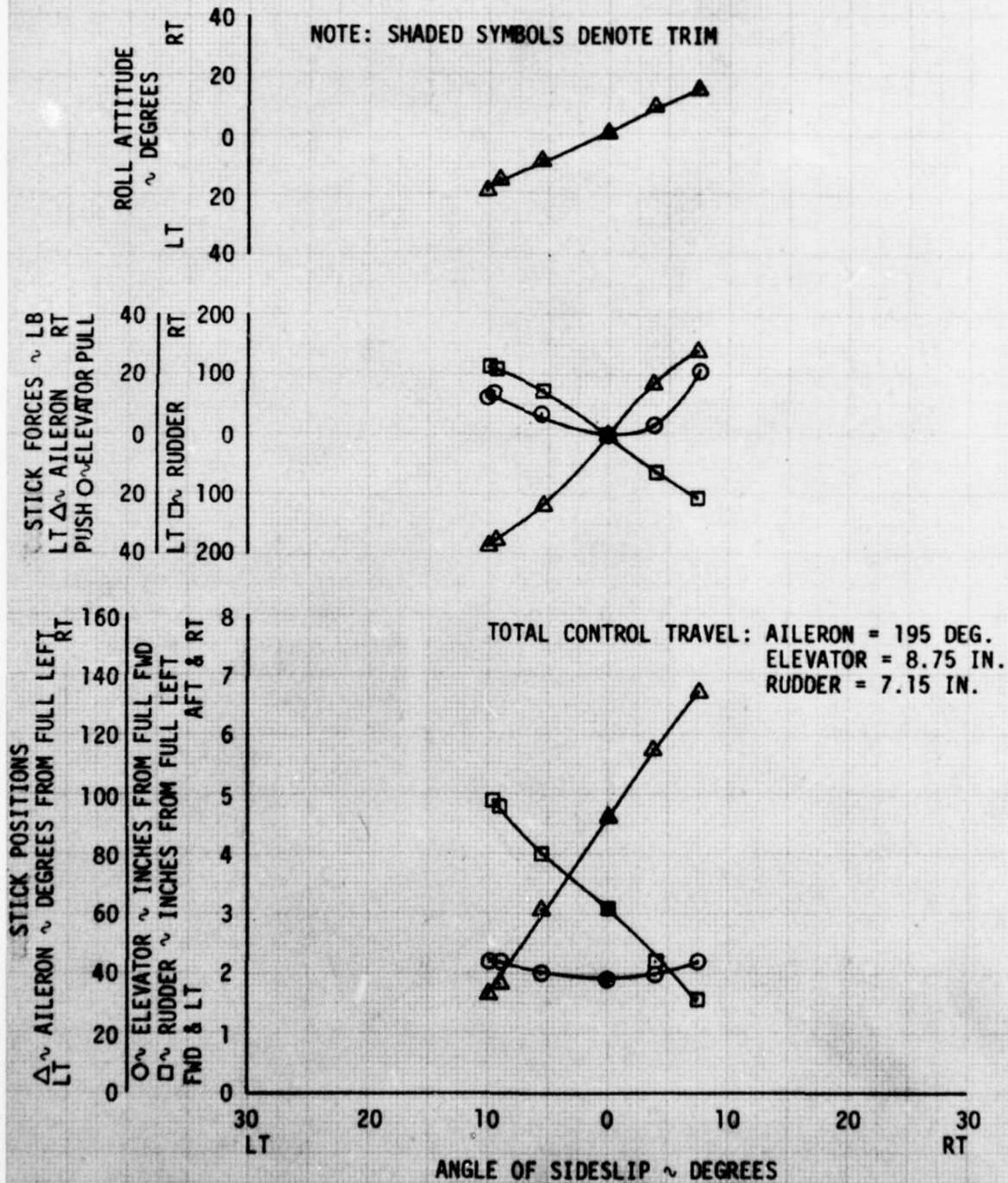

FIGURE 24
STATIC LATERAL-DIRECTIONAL STABILITY
U-21A USA S/N 66-18008
IR PAINTED AIRCRAFT WITH IR SUPPRESSORS

| AVG GROSS WEIGHT | AVG LONG CG LOCATION | AVG DENSITY ALTITUDE | AVG OAT | TRIM AIRSPEED | PROPELLER SPEED | CONFIGURATION | FLIGHT CONDITION |
|------------------|----------------------|----------------------|---------|---------------|-----------------|---------------|------------------|
| ~ LB | ~ FS | ~ FT | ~ °C | ~ KCAS | ~ RPM | | |
| 8540 | 158.3 (FWD) | 11100 | 6.5 | 173 | 1900 | CRUISE | LEVEL FLIGHT |

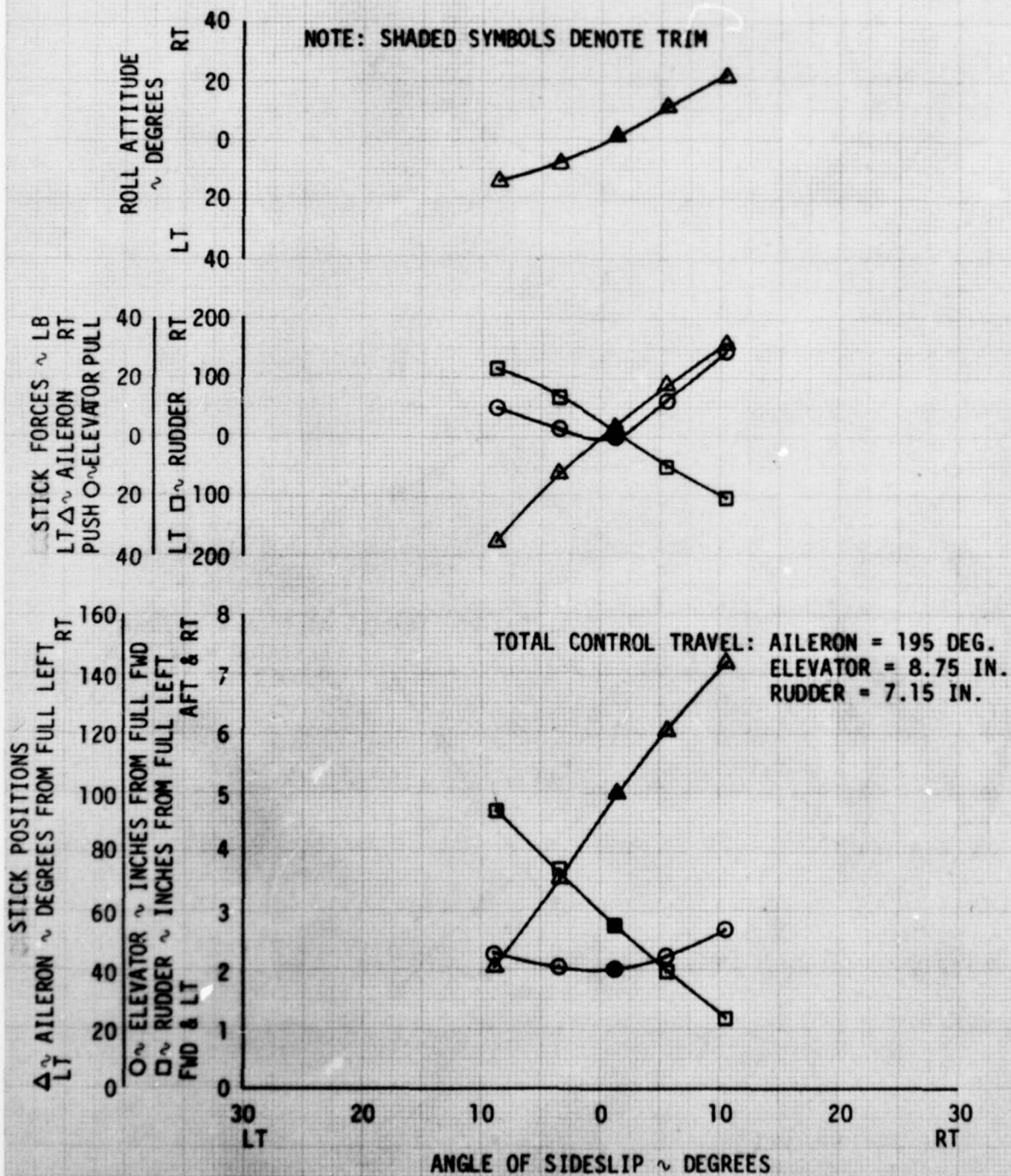

FIGURE 25
 DUTCH ROLL
 U-21A USAF S/N 68-19008
 IR PRINTED AIRCRAFT WITH IR SUPPRESSORS
 CONFIGURATION POWER APPROACH FLIGHT CONDITION
 TRIM AIRSPEED
 ALTITUDE (FT) 10600 TRIM (DEG C) 5.6 AIRSPEED (KTS) 114
 LONG CG LOCATION (IN) 169.5 (AFT) PROPELLER SPEED (RPM) 2000
 GROSS WEIGHT (LB) 9260

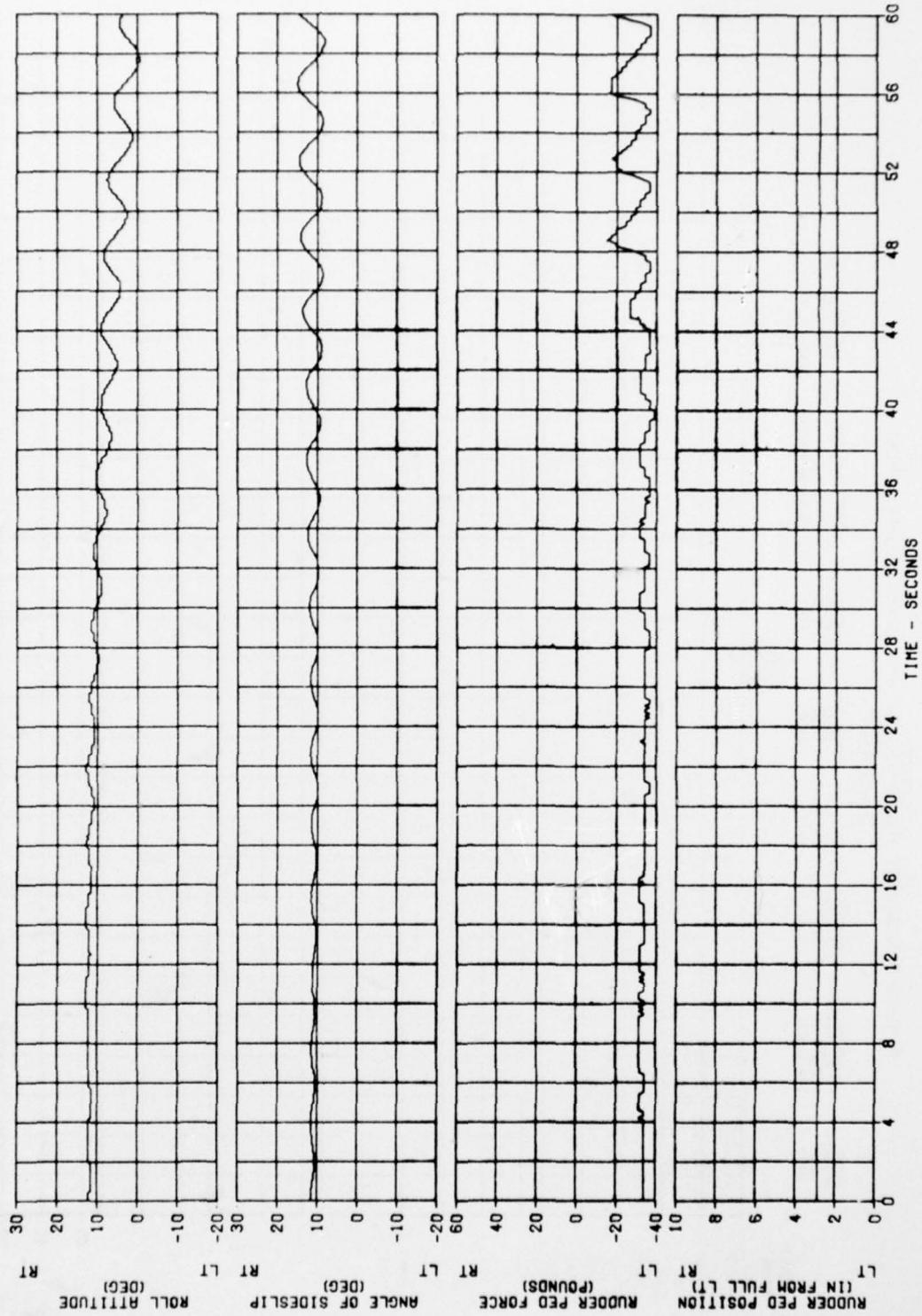

FIGURE 26
 AIRCRAFT RESPONSE FOLLOWING AN AFT LONGITUDINAL PULSE
 U-21A USA S/N 66-18008
 BASIC AIRCRAFT

CROSS WEIGHT (LB) 9310
 LONG CG LOCATION (IN) 159.7 (AFT)
 DENSITY ALTITUDE (FT) 12180
 ORT (DEG C) 14.1
 PROPELLER SPEED (RPM) 2000
 TRIM AIRSPEED (KT) 118
 CONFIGURATION POWER APPROACH
 FLIGHT CONDITION LEVEL FLIGHT

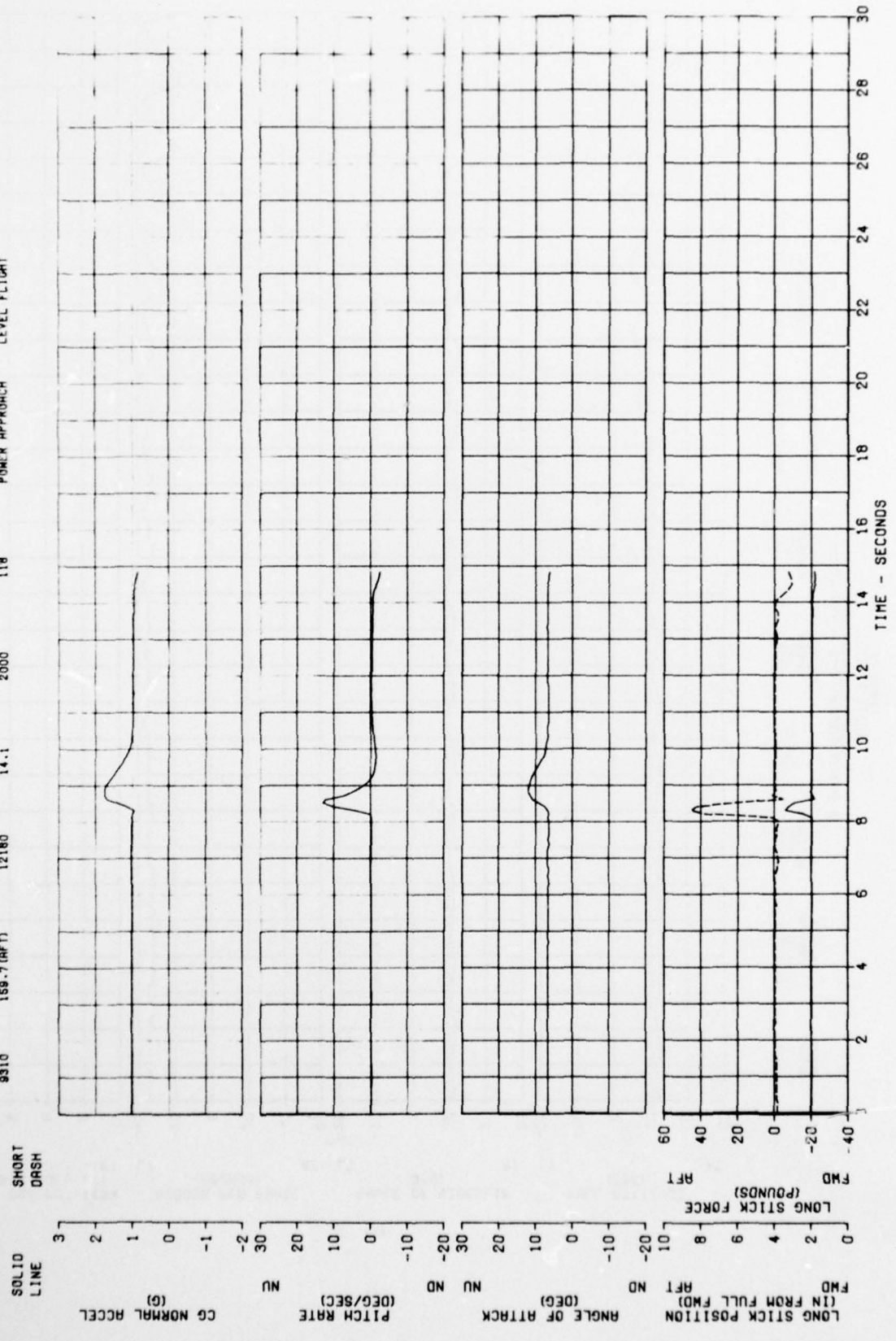

FIGURE 27
 AIRCRAFT RESPONSE FOLLOWING A LONGITUDINAL CONTROL DOUBLET

IR PRINTED AIRCRAFT WITH IR SUPPRESSORS

| | | | | | | | | | |
|-----------------------|-------------|-----------------------|-------|----------------------|------|-----|-----|------------------|----------------|
| GROSS WEIGHT (LB) | 8460 | ORF | ORF | PARALLEL SPEED (RPM) | 2000 | IAS | 118 | FLIGHT CONDITION | LEVEL FLIGHT |
| LONG CG POSITION (IN) | 169.8 (AFT) | DENSITY ALTITUDE (FT) | 14500 | ORF (DEG C) | 6.7 | IAS | 118 | CONFIGURATION | POWER APPROACH |

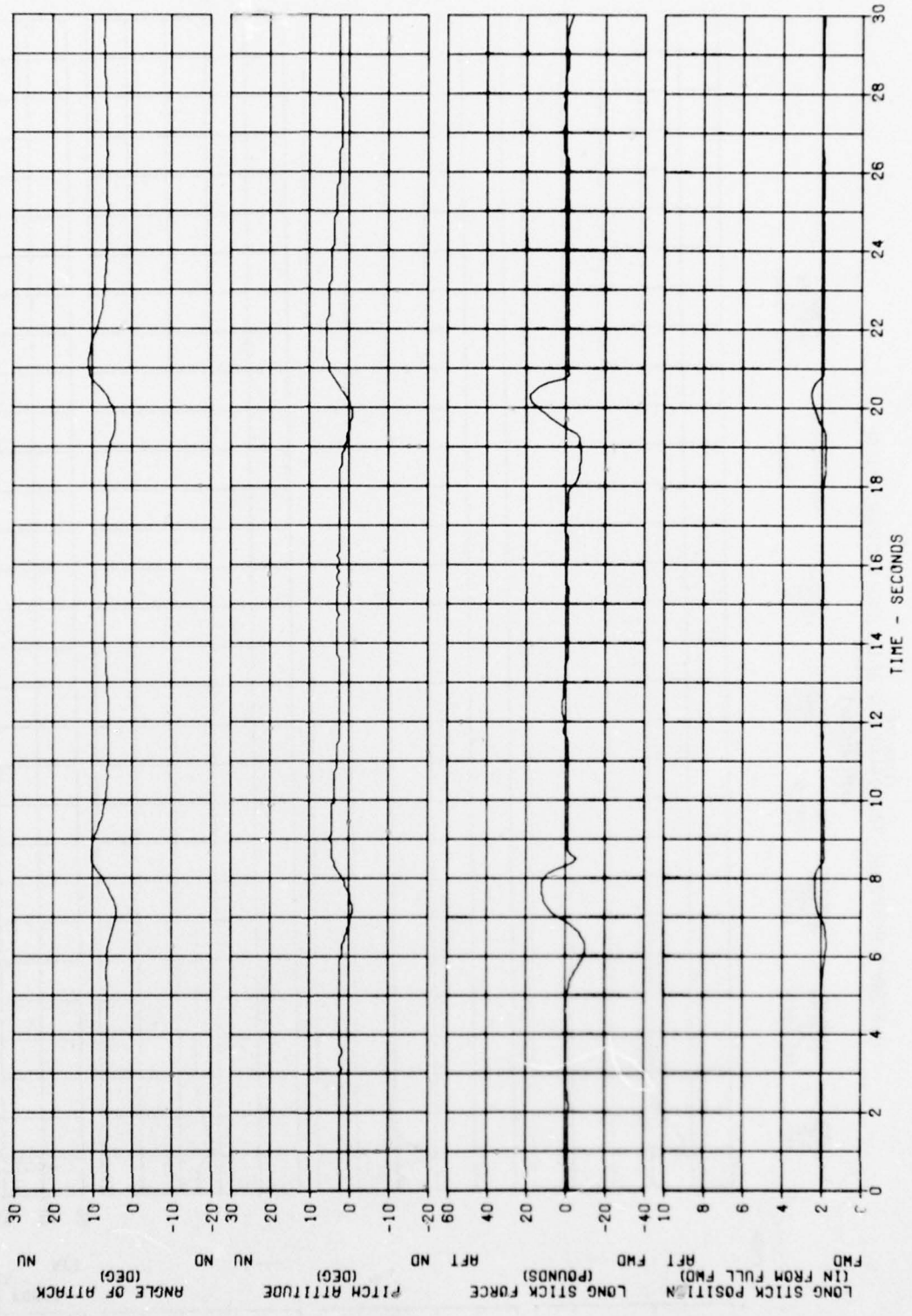

FIGURE 28
 AIRCRAFT RESPONSE FOLLOWING AN AFT LONGITUDINAL PULSE
 U-21A USA S/N 66-18008
 BASIC AIRCRAFT

CROSS HEIGHT 6820
 LONG CG POSITION 158-0 (AFT)
 DENSITY ALTITUDE 12410
 ORT (DEG C) 11.6
 PROPELLER RPM 1900
 TRAIL SPEED 158
 CONFIGURATION CRUISE
 FLIGHT CONDITION LEVEL FLIGHT

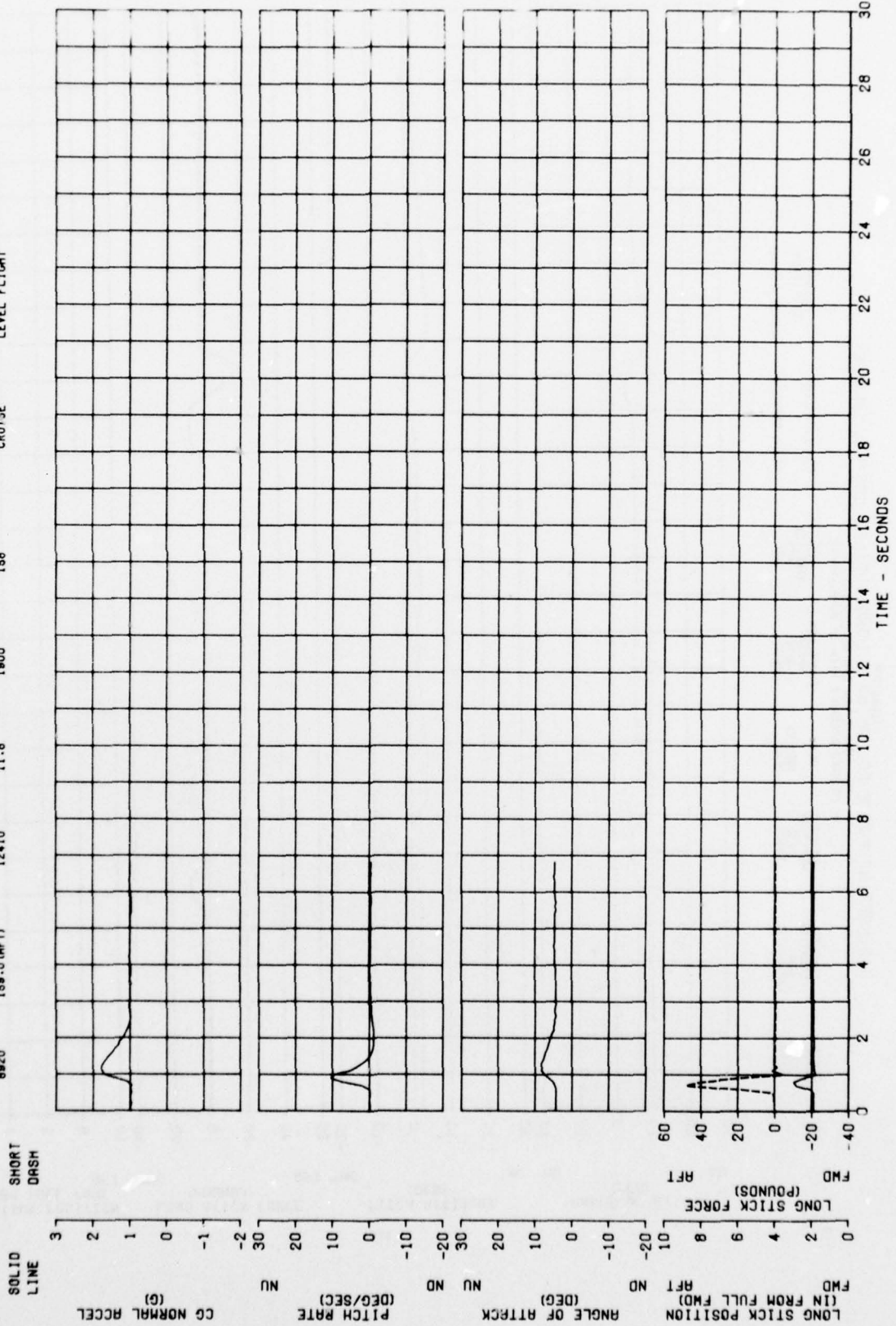

FIGURE 29
 DYNAMIC LONGITUDINAL STABILITY (PHUGOID)

U-21A USR S/N 66-8008
 IR PRINTED AIRCRAFT WITH IR SUPPRESSORS

| | | | | | | | | | | | | | |
|-----------------------|-------------|-----------------------|-------|-------------|-----|------------------------|------|--------------------|-----|---------------|----------------|------------------|--------------|
| GROSS WEIGHT (LBS) | 9420 | DENSITY ALTITUDE (FT) | 10910 | ORF (DEG C) | 6.9 | PROPPELLER SPEED (RPM) | 2000 | TRIM AIRSPEED (KT) | 118 | CONFIGURATION | POWER APPROACH | FLIGHT CONDITION | LEVEL FLIGHT |
| LONG CG LOCATION (IN) | 159.9 (AFT) | | | | | | | | | | | | |

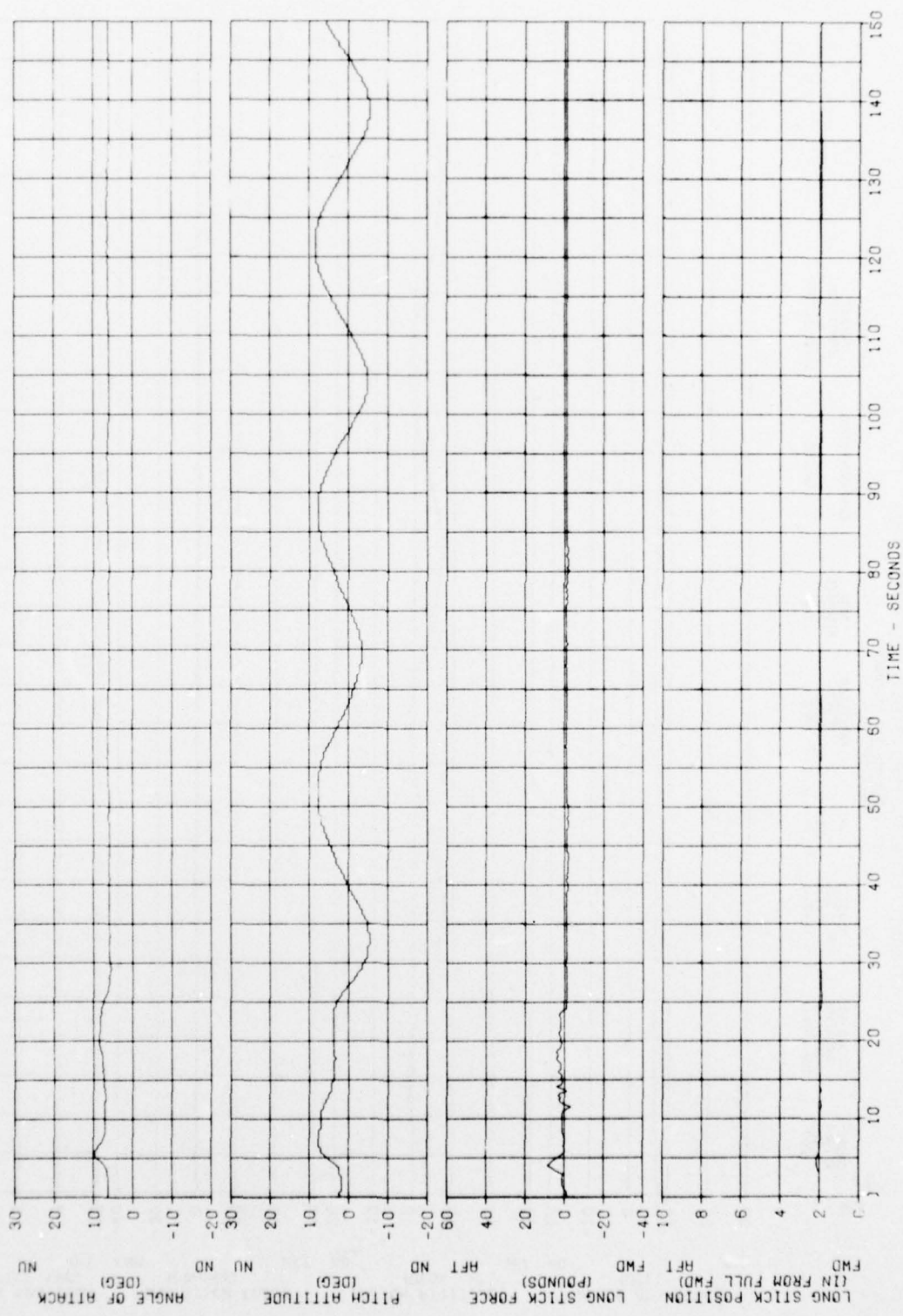

FIGURE 30
 DYNAMIC LONGITUDINAL STABILITY (PHUGOID)

U-21A, USAF, SN, 86-18008
 BASIC AIRCRAFT

| | | | | | | | | | | | | | |
|-----------------------|-------------|-----------------------|-------|--------------|------|-----------------------|------|--------------------|-----|---------------|--------|------------------|--------------|
| GROSS WEIGHT (LB) | 9200 | DENSITY ALTITUDE (FT) | 11400 | DART (DEG C) | 15.4 | PROPELLER SPEED (RPM) | 1900 | TRIM AIRSPEED (KT) | 141 | CONFIGURATION | CRUISE | FLIGHT CONDITION | LEVEL FLIGHT |
| LONG CG LOCATION (IN) | 159.4 (AFT) | | | | | | | | | | | | |

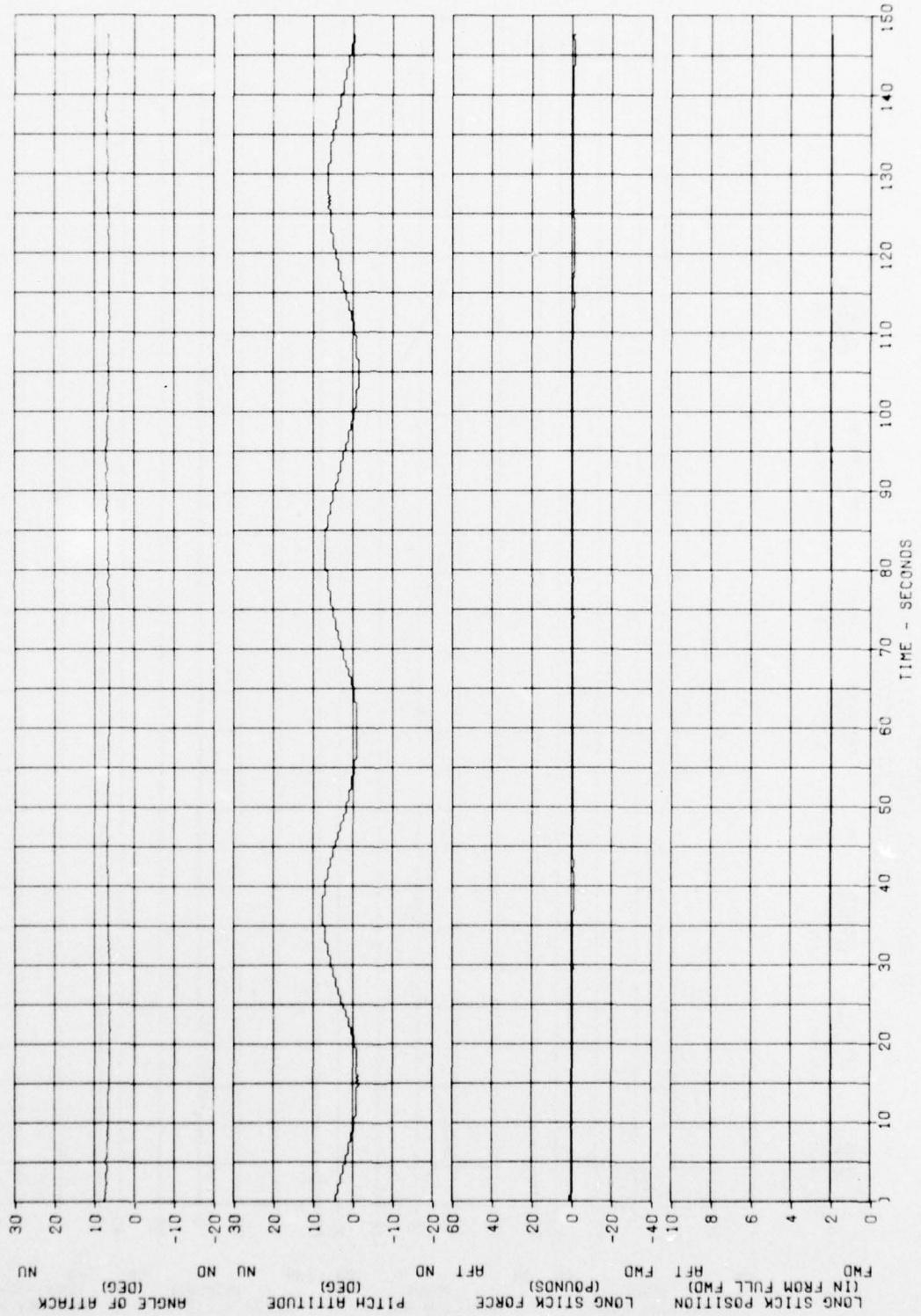

FIGURE 3/
DYNAMIC LONGITUDINAL STABILITY (PHUGOID)

U-21A USA S/N 66-18008

IR PRINTED AIRCRAFT WITH IR SUPPRESSORS

TRIM AIRSPEED 142

PROPELLER SPEED 1900

DRT (DEG C) 7.7

DENSITY ALTITUDE 11260

LONG CG LOCATION 159.1

GROSS WEIGHT 8990

CONFIGURATION CRUISE

FLIGHT CONDITION LEVEL FLIGHT

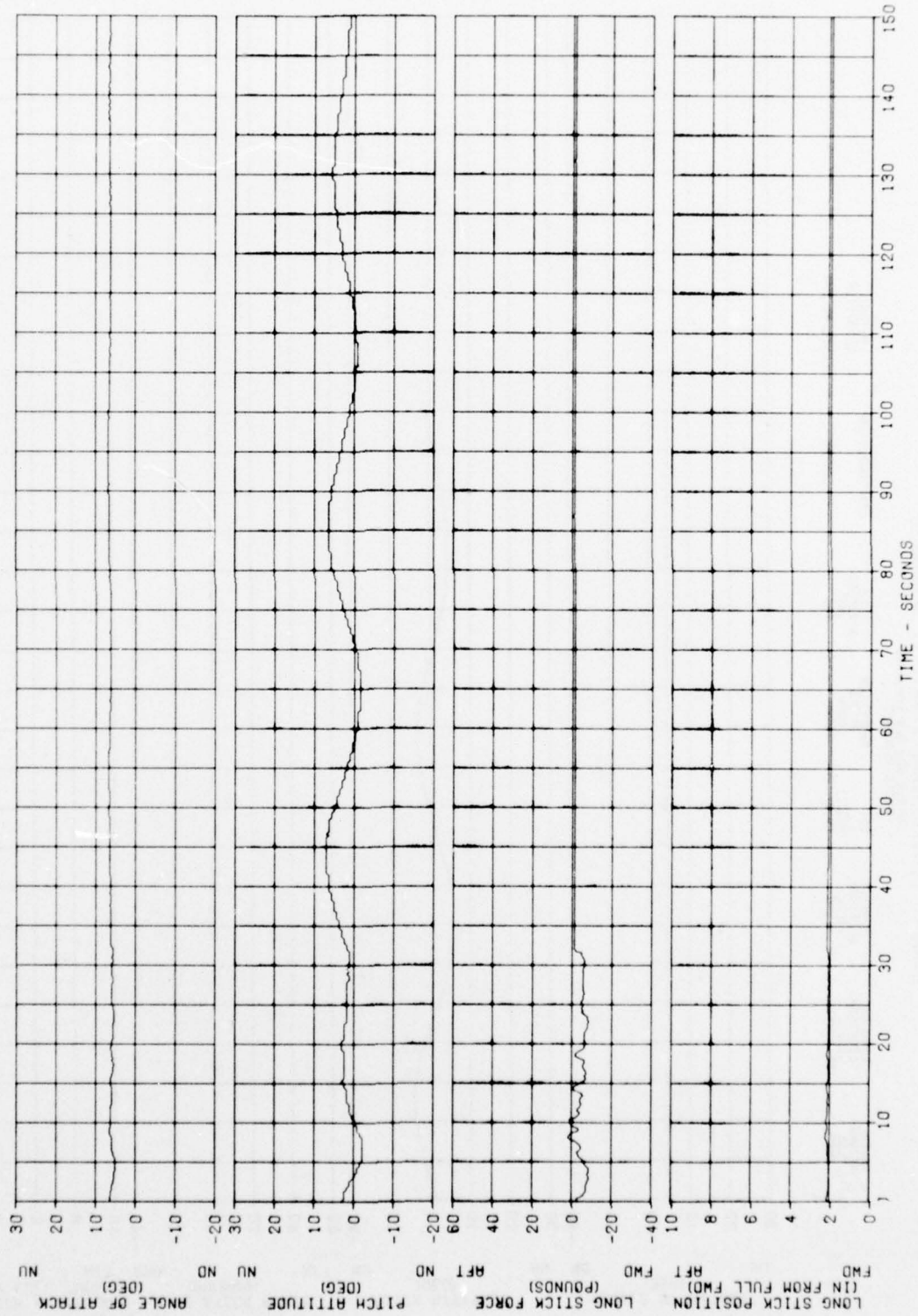

FIGURE 32
 DYNAMIC LONGITUDINAL STABILITY (PHUGOID)

U-218 USA S/N 66-10008
 BASIC AIRCRAFT

GROSS WEIGHT (LB) 8630
 LONG CG LOCATION (IN) 188.8 (AFT)
 DENSITY ALTITUDE (FT) 12370
 ORT (DEG C) 11.8
 PROPELLER SPEED (RPM) 1900
 TRIM AIRSPEED (KT) 188
 CONFIGURATION CRUISE
 FLIGHT CONDITION LEVEL FLIGHT

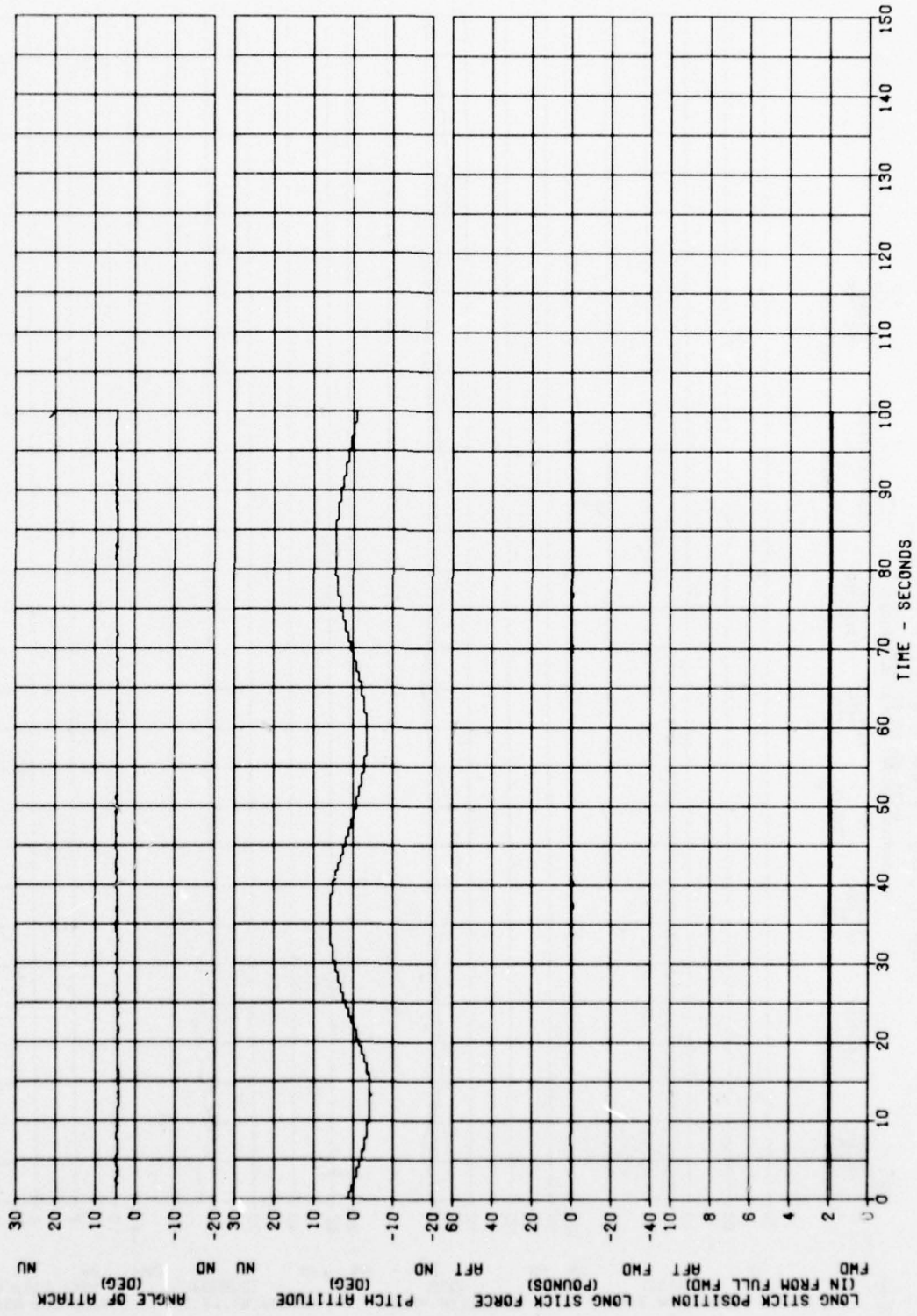

FIGURE 33
 AIRCRAFT RESPONSE FOLLOWING A RUDDER DOUBLET

U-21A USA S/N 98-18008
 BASIC AIRCRAFT

| | | | | | | | | | | | | | |
|-----------------------|-------------|-----------------------|-------|-------------|------|-----------------------|------|--------------------|-----|---------------|----------------|------------------|--------------|
| GROSS WEIGHT (LB) | 9440 | DENSITY ALTITUDE (FT) | 11940 | ORF (DEG C) | 14.0 | PROPELLER SPEED (RPM) | 2000 | TRIM AIRSPEED (KT) | 119 | CONFIGURATION | POWER APPROACH | FLIGHT CONDITION | LEVEL FLIGHT |
| LONG CD LOCATION (IN) | 189.9 (AFT) | | | | | | | | | | | | |

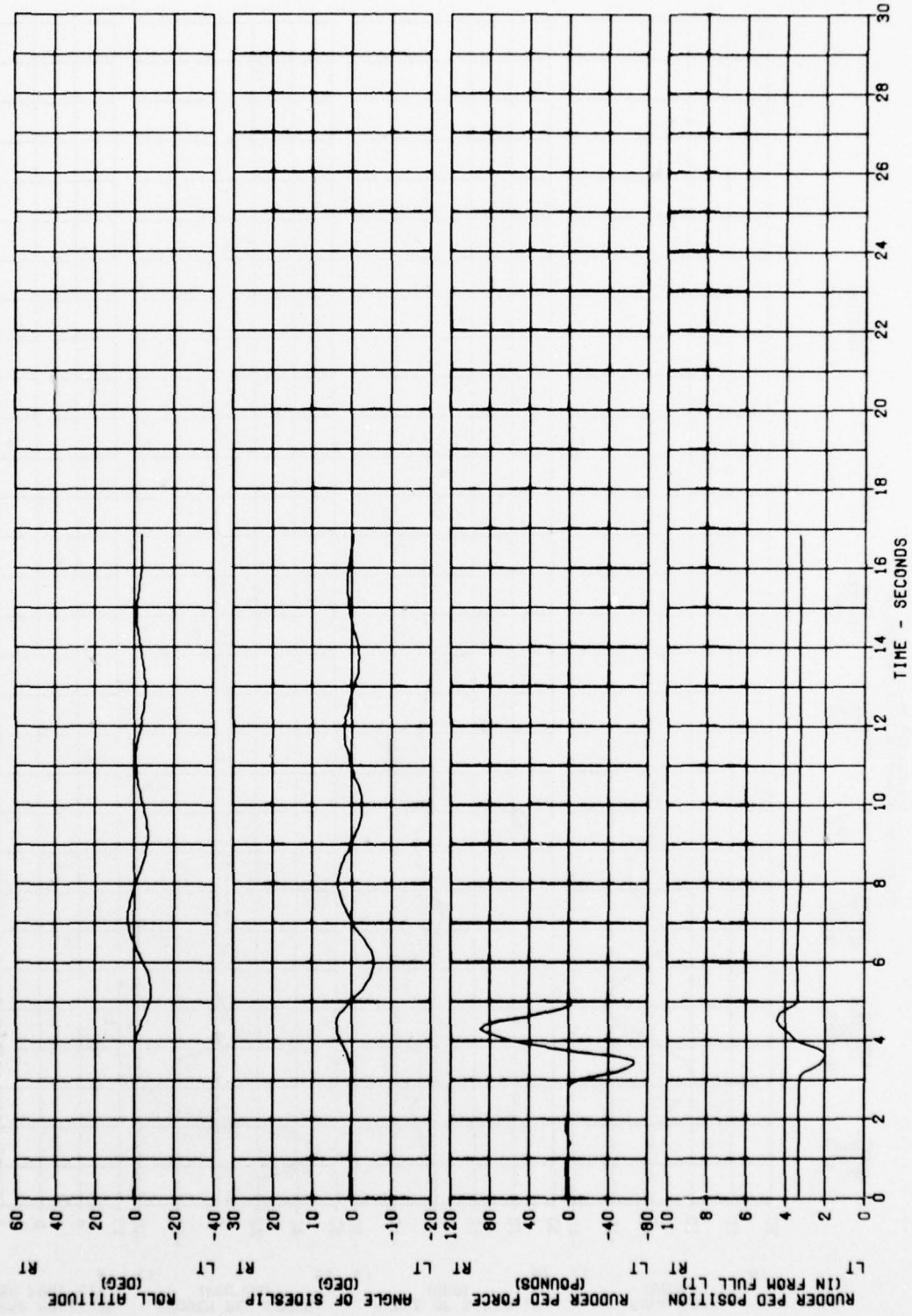

FIGURE 34
DUTCH ROLL
 U-21A USA S/N 66-18008
 IR PRINTED AIRCRAFT WITH IR SUPPRESSORS
 CONFIGURATION CRUISE
 FLIGHT CONDITION LEVEL FLIGHT
 TRIM AIRSPEED (KT) 142
 PROPELLER SPEED (RPM) 1800
 ORT (DEG C) 7.0
 DENSITY ALTITUDE (FT) 11390
 LONG CG LOCATION (IN) 169.0 (AFT)
 GROSS WEIGHT (LB) 8970

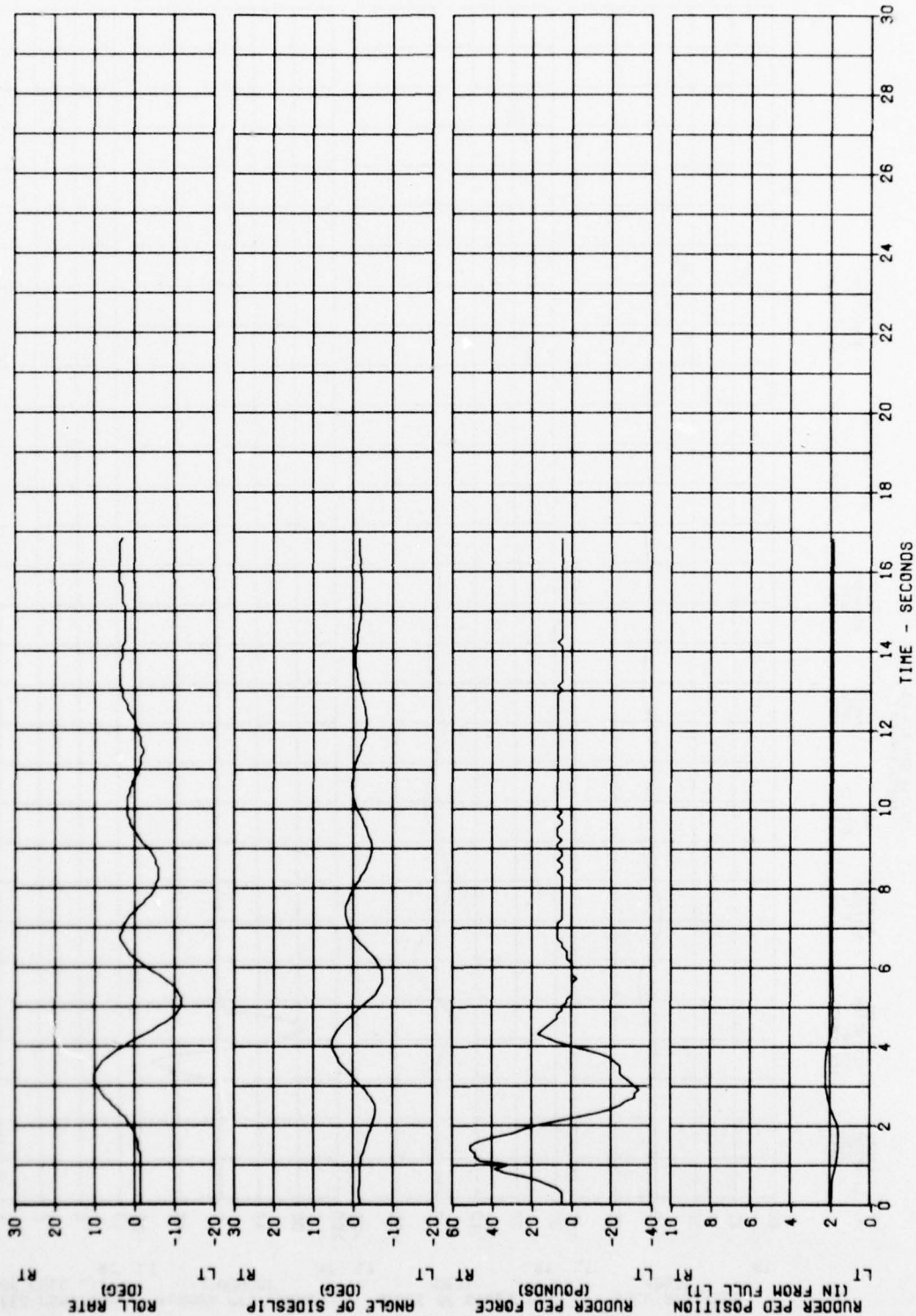
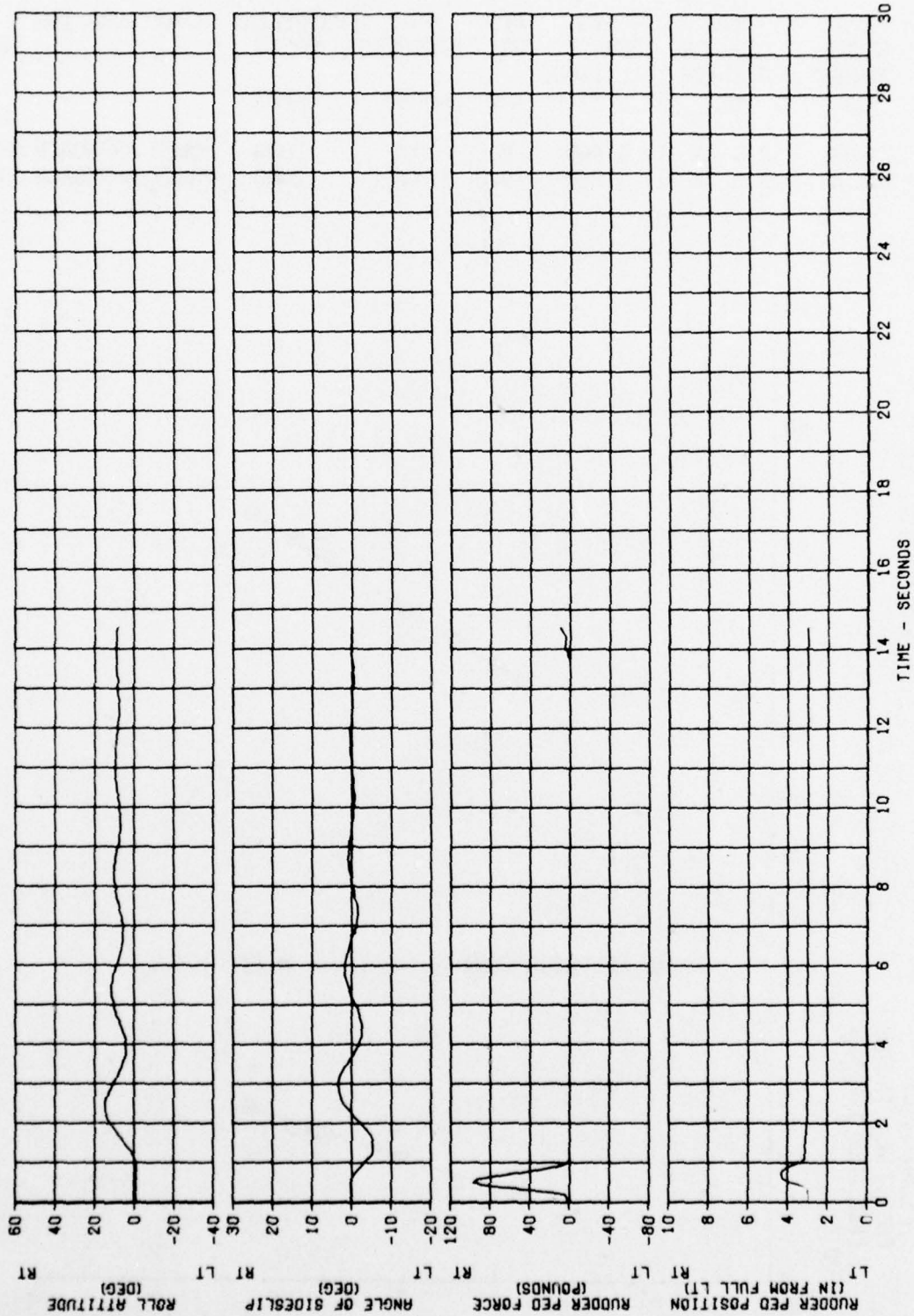

FIGURE 35
 AIRCRAFT RESPONSE FOLLOWING A RUDDER DOUBLET

U-21A USA S/N 66-10008
 BASIC AIRCRAFT

| | | | | | | | | | | | | | |
|-------------------|------|-----------------------|-------|-------------|------|-----------------------|------|--------------------|-----|---------------|--------|------------------|--------------|
| GRASS WEIGHT (LB) | 9770 | DENSITY ALTITUDE (FT) | 12200 | ORF (DEG C) | 12.1 | PROPELLER SPEED (RPM) | 1900 | TRIM AIRSPEED (KT) | 161 | CONFIGURATION | CRUISE | FLIGHT CONDITION | LEVEL FLIGHT |
|-------------------|------|-----------------------|-------|-------------|------|-----------------------|------|--------------------|-----|---------------|--------|------------------|--------------|



**FIGURE 36
MANEUVERING STABILITY
U-21A USA S/N 66-18008
IR PAINTED AIRCRAFT WITH IR SUPPRESSORS**

| SYM | AVG GROSS WEIGHT ~LB | AVG LONG CG LOCATION ~FS | AVG DENSITY ALTITUDE ~FT | AVG OAT ~°C | TRIM AIRSPEED ~KCAS | PROPELLER SPEED ~RPM | CONFIGURATION | FLIGHT CONDITION |
|-----|-------------------------|-----------------------------|-----------------------------|----------------|------------------------|-------------------------|----------------|------------------|
| ○ | 9260 | 159.6 (AFT) | 11440 | 9.0 | 117 | 2000 | POWER APPROACH | SYM PULL UP |
| □ | 9230 | 159.5 (AFT) | 11210 | 10.0 | 117 | 2000 | POWER APPROACH | SYM PUSH OVER |

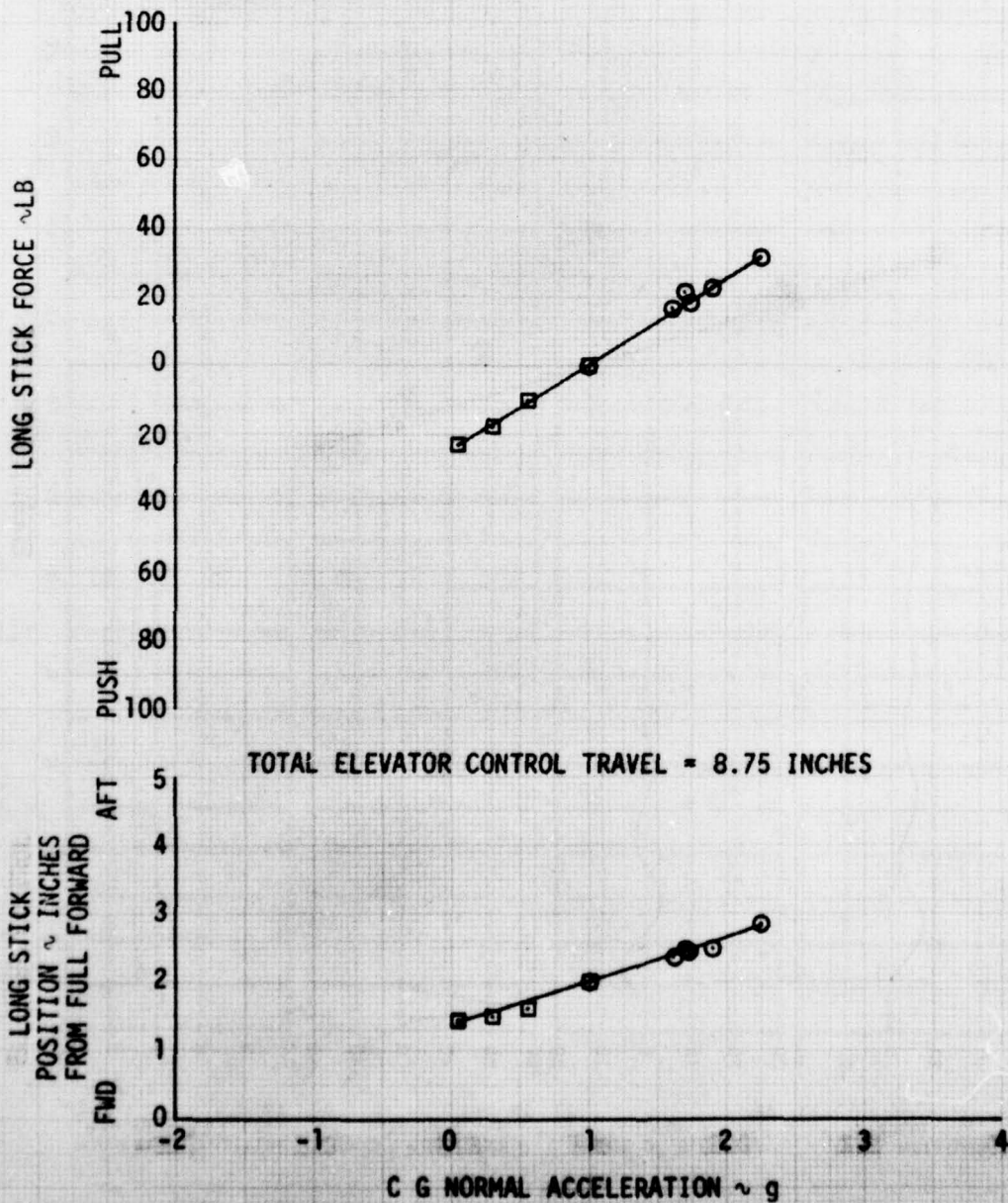

**FIGURE 37
MANEUVERING STABILITY
U-21A USA S/N 66-18008
BASIC AIRCRAFT**

| SYM | AVG GROSS WEIGHT ~LB | AVG LONG CG LOCATION ~FS | AVG DENSITY ALTITUDE ~FT | AVG OAT ~°C | TRIM AIRSPEED ~KCAS | PROPELLER SPEED ~RPM | CONFIGURATION | FLIGHT CONDITION |
|-----|----------------------|--------------------------|--------------------------|-------------|---------------------|----------------------|---------------|------------------|
| ○ | 9060 | 159.2(AFT) | 11920 | 11.5 | 141 | 1900 | CRUISE | SYM PULL UP |
| □ | 9050 | 159.2(AFT) | 11840 | 12.5 | 138 | 1900 | CRUISE | SYM PUSH OVER |
| △ | 9040 | 159.2(AFT) | 11250 | 13.5 | 140 | 1900 | CRUISE | SYM PULL UP |

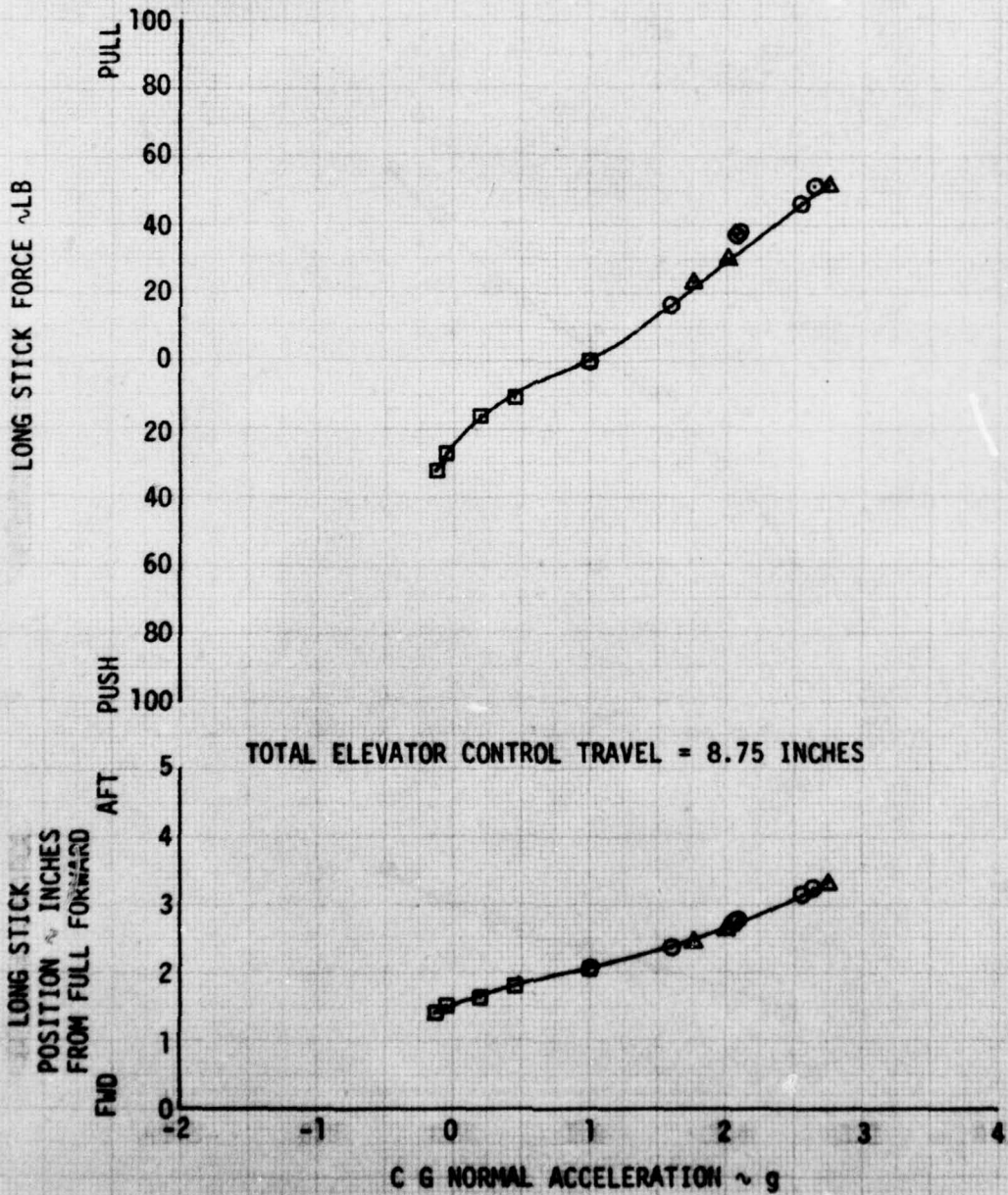

FIGURE 38
 MANEUVERING STABILITY
 U-21A USA S/N 66-18008
 IR PAINTED AIRCRAFT WITH IR SUPPRESSORS

| SYM | AVG GROSS WEIGHT ~LB | AVG LONG CG LOCATION ~FS | AVG DENSITY ALTITUDE ~FT | AVG OAT ~°C | TRIM AIRSPEED ~KCAS | PROPELLER SPEED ~RPM | CONFIGURATION | FLIGHT CONDITION |
|-----|----------------------|--------------------------|--------------------------|-------------|---------------------|----------------------|---------------|------------------|
| ○ | 8900 | 158.9(AFT) | 11730 | 9.5 | 140 | 1900 | CRUISE | SYM PULL UP |
| □ | 8880 | 158.9(AFT) | 11400 | 10.0 | 138 | 1900 | CRUISE | SYM PUSH OVER |

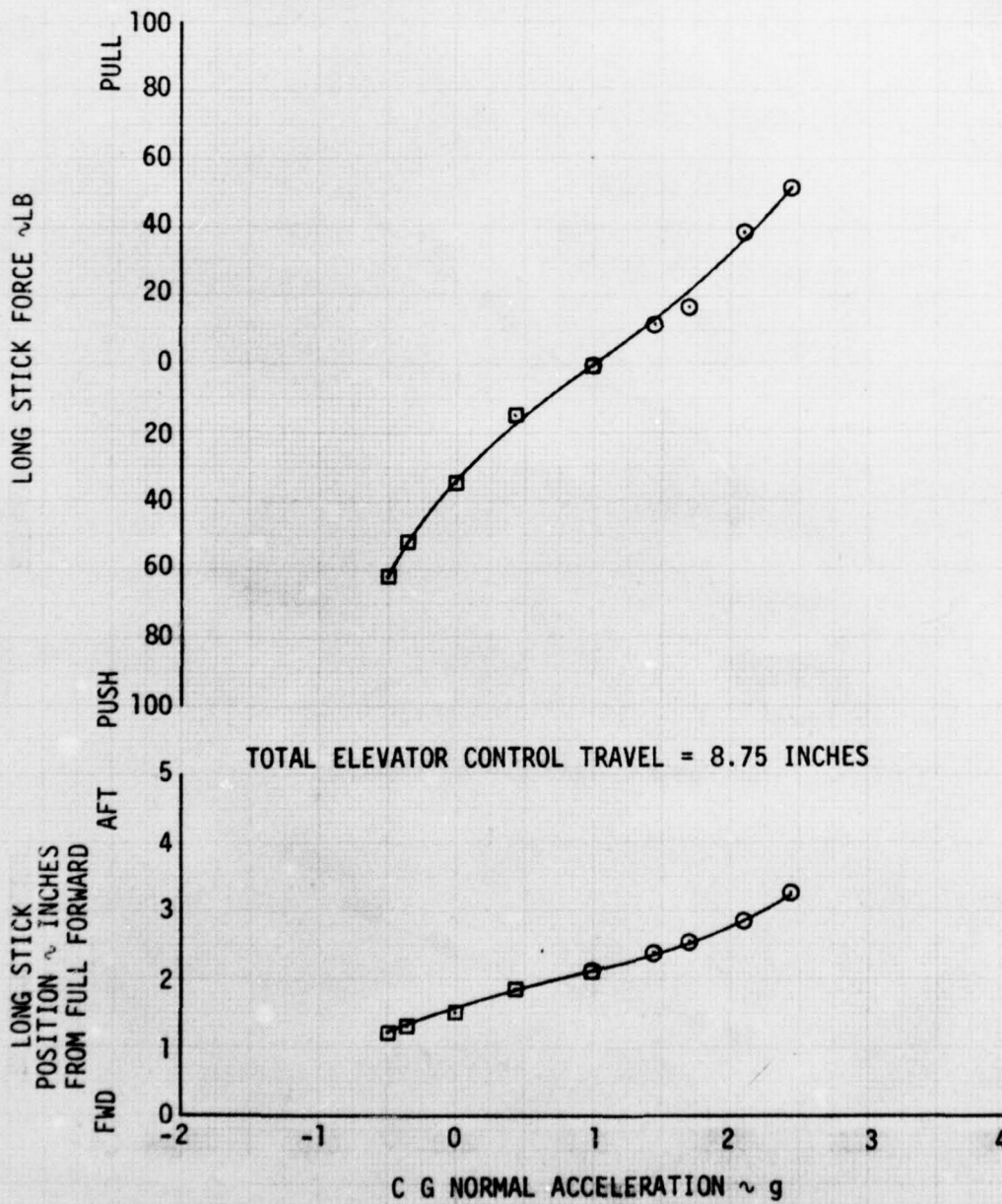
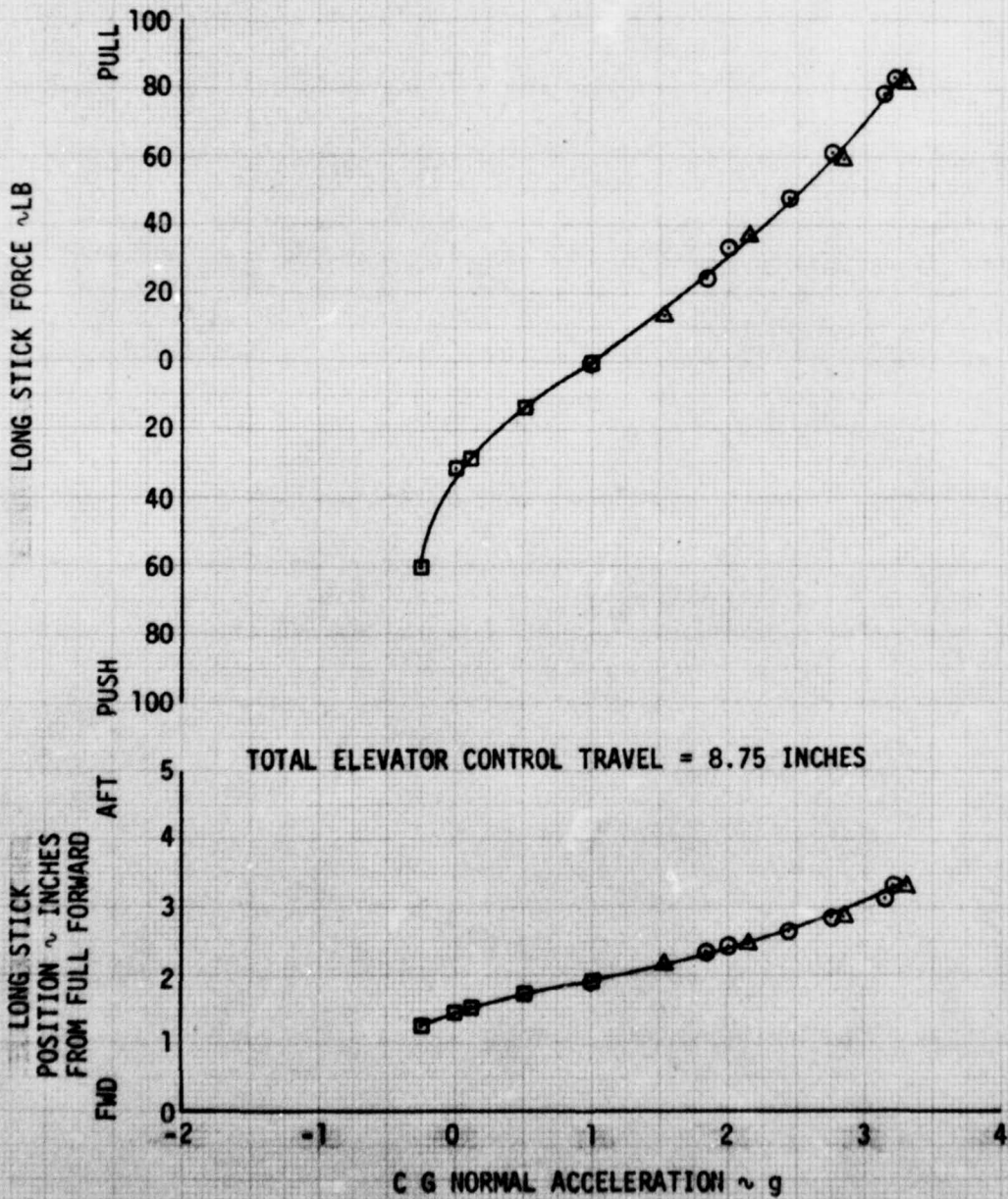

FIGURE 39
 MANEUVERING STABILITY
 U-21A USA S/N 66-18008
 BASIC AIRCRAFT

| SYM | AVG GROSS WEIGHT ~LB | AVG LONG CG LOCATION ~FS | AVG DENSITY ALTITUDE ~FT | AVG OAT ~°C | TRIM AIRSPEED ~KCAS | PROPELLER SPEED ~RPM | CONFIGURATION | FLIGHT CONDITION |
|-----|-------------------------|-----------------------------|-----------------------------|----------------|------------------------|-------------------------|---------------|------------------|
| ○ | 9390 | 159.8(AFT) | 11850 | 10.5 | 168 | 1900 | CRUISE | SYM PULL UP |
| □ | 9380 | 159.8(AFT) | 11160 | 13.0 | 169 | 1900 | CRUISE | SYM PUSH OVER |
| △ | 9300 | 159.7(AFT) | 11800 | 10.0 | 172 | 1900 | CRUISE | SUDDEN PULLUP |



**FIGURE 40
MANEUVERING STABILITY
U-21A USA S/N 66-18008
IR PAINTED AIRCRAFT WITH IR SUPPRESSORS**

| AVG GROSS WEIGHT ~LB | AVG LONG CG LOCATION ~FS | AVG DENSITY ALTITUDE ~FT | AVG QAT ~°C | TRIM AIRSPEED ~KCAS | PROPELLER SPEED ~RPM | CONFIGURATION | FLIGHT CONDITION |
|-------------------------|-----------------------------|-----------------------------|----------------|------------------------|-------------------------|---------------|------------------|
| 8740 | 158.6(AFT) | 11710 | 9.5 | 154 | 1900 | CRUISE | SYM PULL UP |

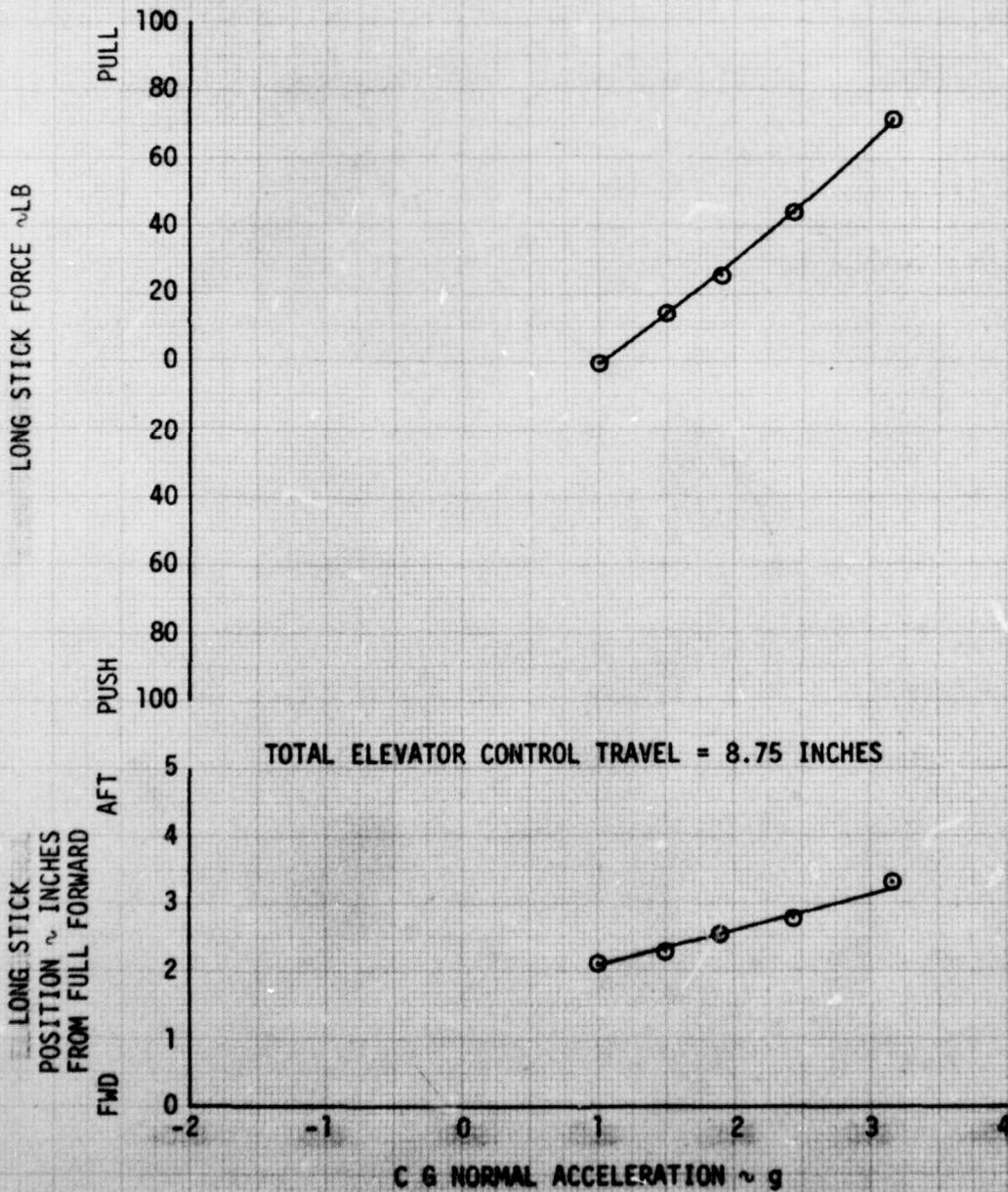

**FIGURE 41
MANEUVERING STABILITY
U-21A USA S/N 66-18008
IR PAINTED AIRCRAFT WITH IR SUPPRESSORS**

| SYM | AVG GROSS WEIGHT ~LB | AVG LONG CG LOCATION ~FS | AVG DENSITY ALTITUDE ~FT | AVG OAT ~°C | TRIM AIRSPEED ~KCAS | PROPELLER SPEED ~RPM | CONFIGURATION | FLIGHT CONDITION |
|-----|-------------------------|-----------------------------|-----------------------------|----------------|------------------------|-------------------------|----------------|------------------|
| ○ | 9080 | 159.3(AFT) | 11730 | 9.5 | 117 | 2000 | POWER APPROACH | STDY LT TURN |
| □ | 9140 | 159.4(AFT) | 12130 | 9.5 | 117 | 2000 | POWER APPROACH | STDY RT TURN |

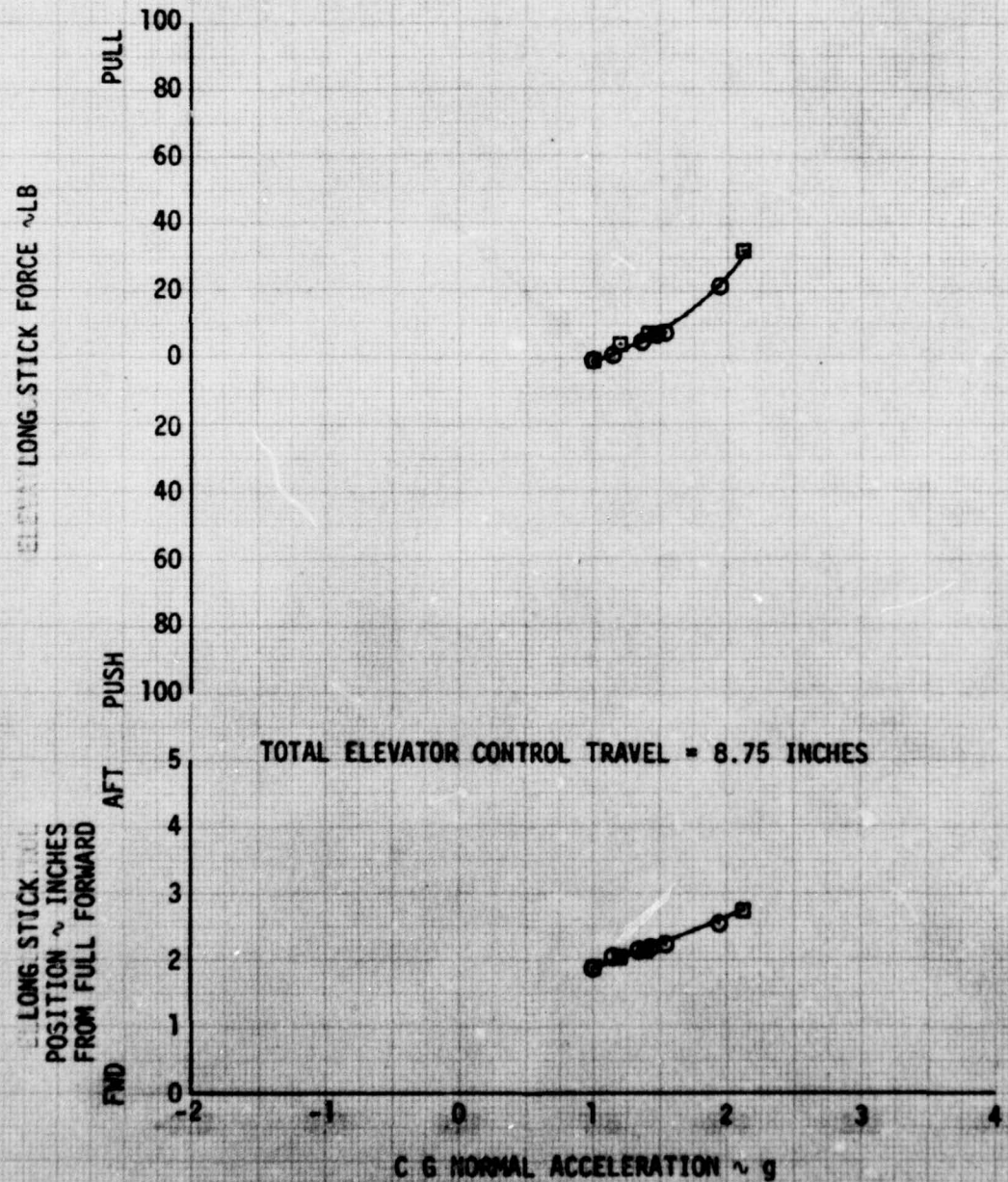

**FIGURE 42
MANEUVERING STABILITY
U-21A USA S/N 66-18008
BASIC AIRCRAFT**

| SYM | AVG GROSS WEIGHT ~LB | AVG LONG CG LOCATION ~FS | AVG DENSITY ALTITUDE ~FT | AVG OAT ~°C | TRIM AIRSPEED ~KCAS | PROPELLER SPEED ~RPM | CONFIGURATION | FLIGHT CONDITION |
|-----|-------------------------|-----------------------------|-----------------------------|----------------|------------------------|-------------------------|---------------|------------------|
| ○ | 9000 | 159.1(AFT) | 12040 | 11.5 | 141 | 1900 | CRUISE | STDY LT TURN |
| □ | 8950 | 159.0(AFT) | 11650 | 9.5 | 135 | 1900 | CRUISE | STDY RT TURN |

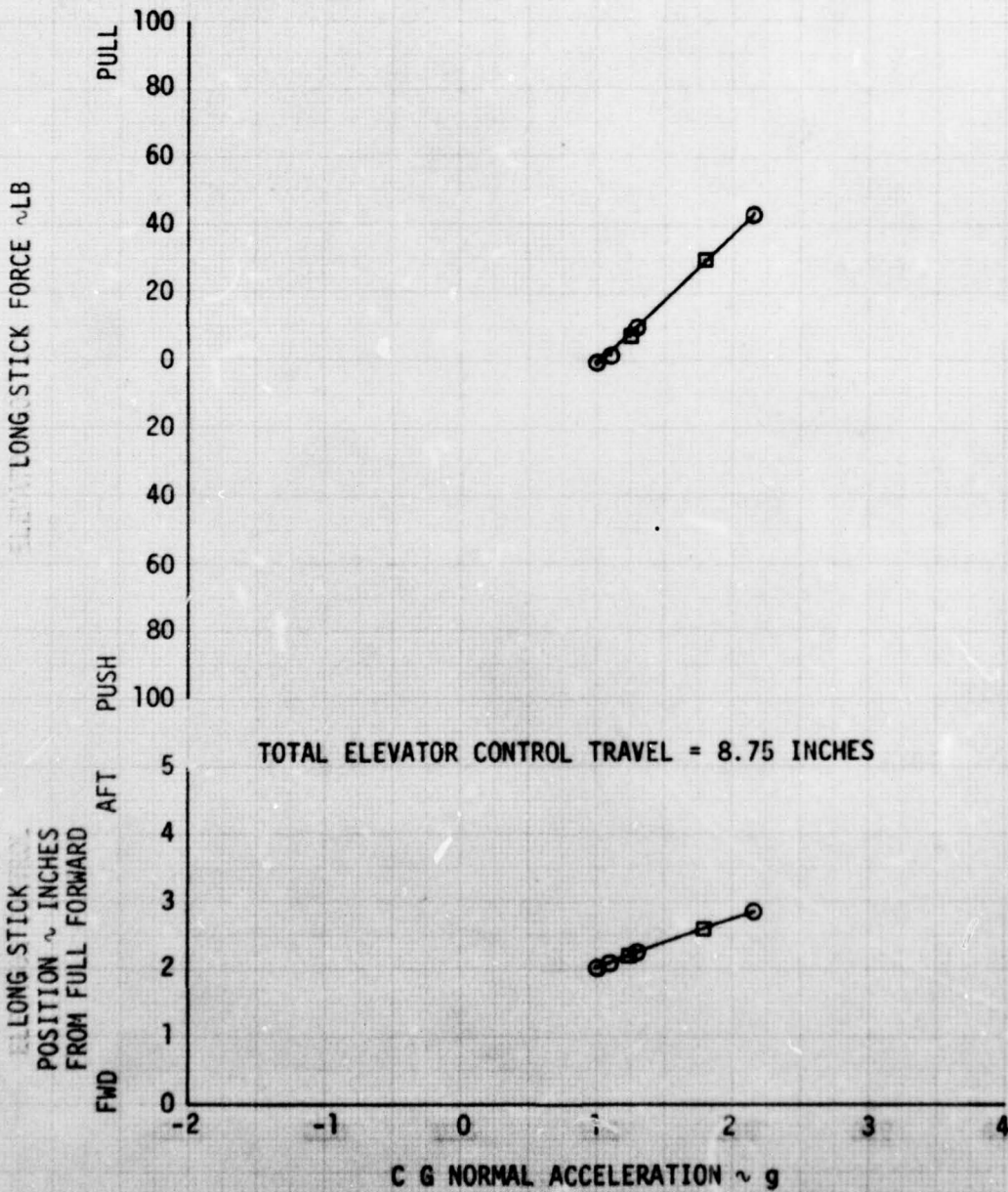

**FIGURE 43
MANEUVERING STABILITY
U-21A USA S/N 66-18008
IR PAINTED AIRCRAFT WITH IR SUPPRESSORS**

| SYM | AVG GROSS WEIGHT ~LB | AVG LONG CG LOCATION ~IPS | AVG DENSITY ALTITUDE ~FT | AVG OAT ~°C | TRIM AIRSPEED ~KCAS | PROPELLER SPEED ~RPM | CONFIGURATION | FLIGHT CONDITION |
|-----|-------------------------|------------------------------|-----------------------------|----------------|------------------------|-------------------------|---------------|------------------|
| ○ | 3760 | 158.7(AFT) | 11720 | 8.0 | 141 | 1900 | CRUISE | STDY LT TURN |
| □ | 8810 | 158.8(AFT) | 11880 | 8.5 | 139 | 1900 | CRUISE | STDY RT TURN |

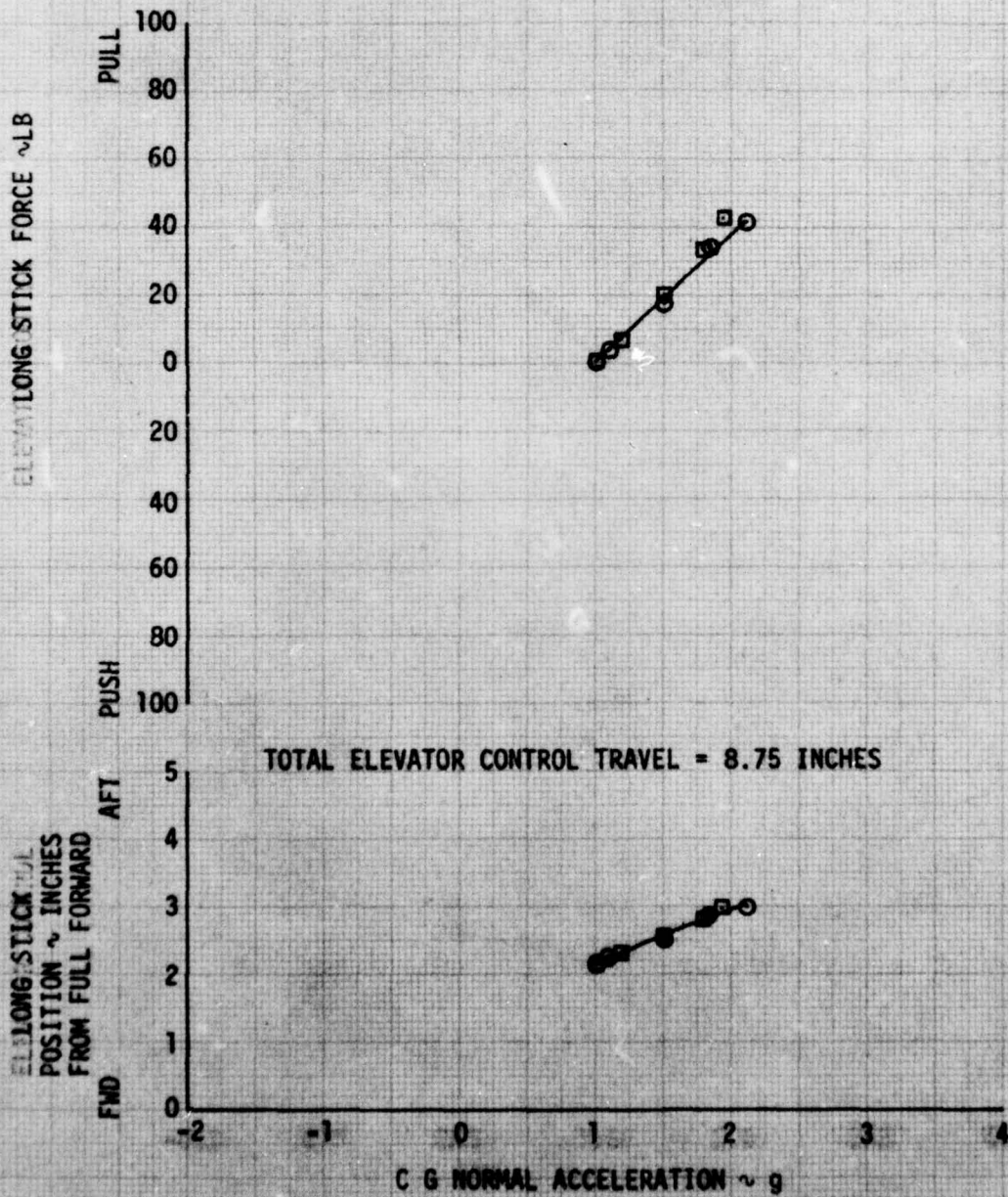

**FIGURE 44
MANEUVERING STABILITY
U-21A USA S/N 66-18008
BASIC AIRCRAFT**

| SYM | AVG GROSS WEIGHT ~LB | AVG LONG CG LOCATION ~FS | AVG DENSITY ALTITUDE ~FT | AVG OAT ~°C | TRIM AIRSPEED ~KCAS | PROPELLER SPEED ~RPM | CONFIUGRATION | FLIGHT CONDITION |
|-----|----------------------|--------------------------|--------------------------|-------------|---------------------|----------------------|---------------|------------------|
| ○ | 9250 | 159.6(AFT) | 12500 | 9.5 | 171 | 1900 | CRUISE | STDY LT TURN |
| □ | 9170 | 159.4(AFT) | 11250 | 8.5 | 172 | 1900 | CRUISE | STDY RT TURN |

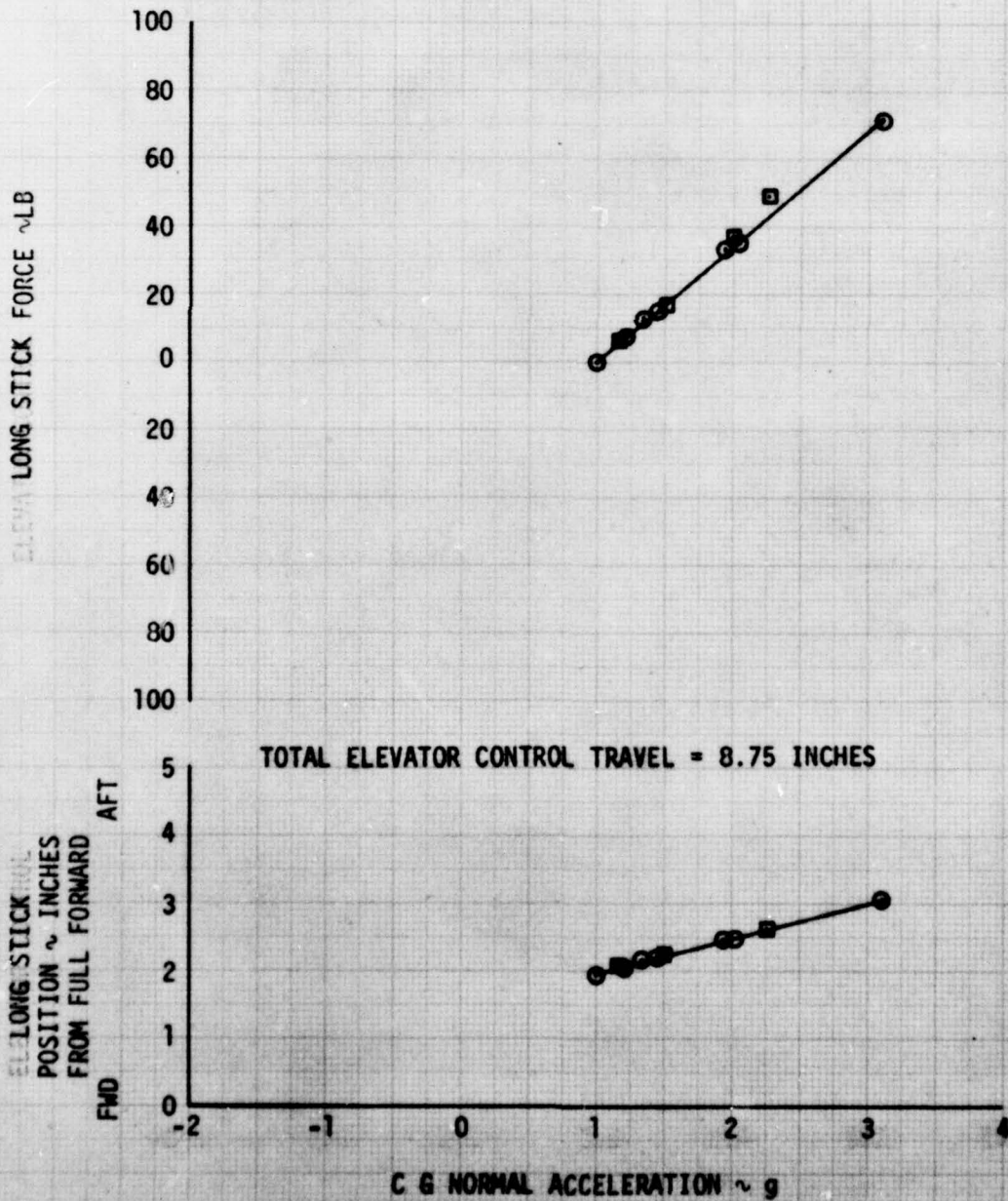

FIGURE 45
 AIRCRAFT RESPONSE FOLLOWING A HALF-INCH LONG, STEP INPUT

U-21A USA B/N 66-10008
 IR PRINTED AIRCRAFT WITH IR SUPPRESSORS

| | | | | | | | | | | | | | |
|--------------------|------|-----------------------|-------|-------------|------|-----------------------|------|--------------------|-----|---------------|----------------|------------------|--------------|
| GRASS WEIGHT (LBS) | 8450 | DENSITY ALTITUDE (FT) | 11740 | ORT (DEG C) | 10.5 | PROPELLER SPEED (RPM) | 2000 | TSIM AIRSPEED (KT) | 118 | CONFIGURATION | POWER APPROACH | FLIGHT CONDITION | LEVEL FLIGHT |
|--------------------|------|-----------------------|-------|-------------|------|-----------------------|------|--------------------|-----|---------------|----------------|------------------|--------------|

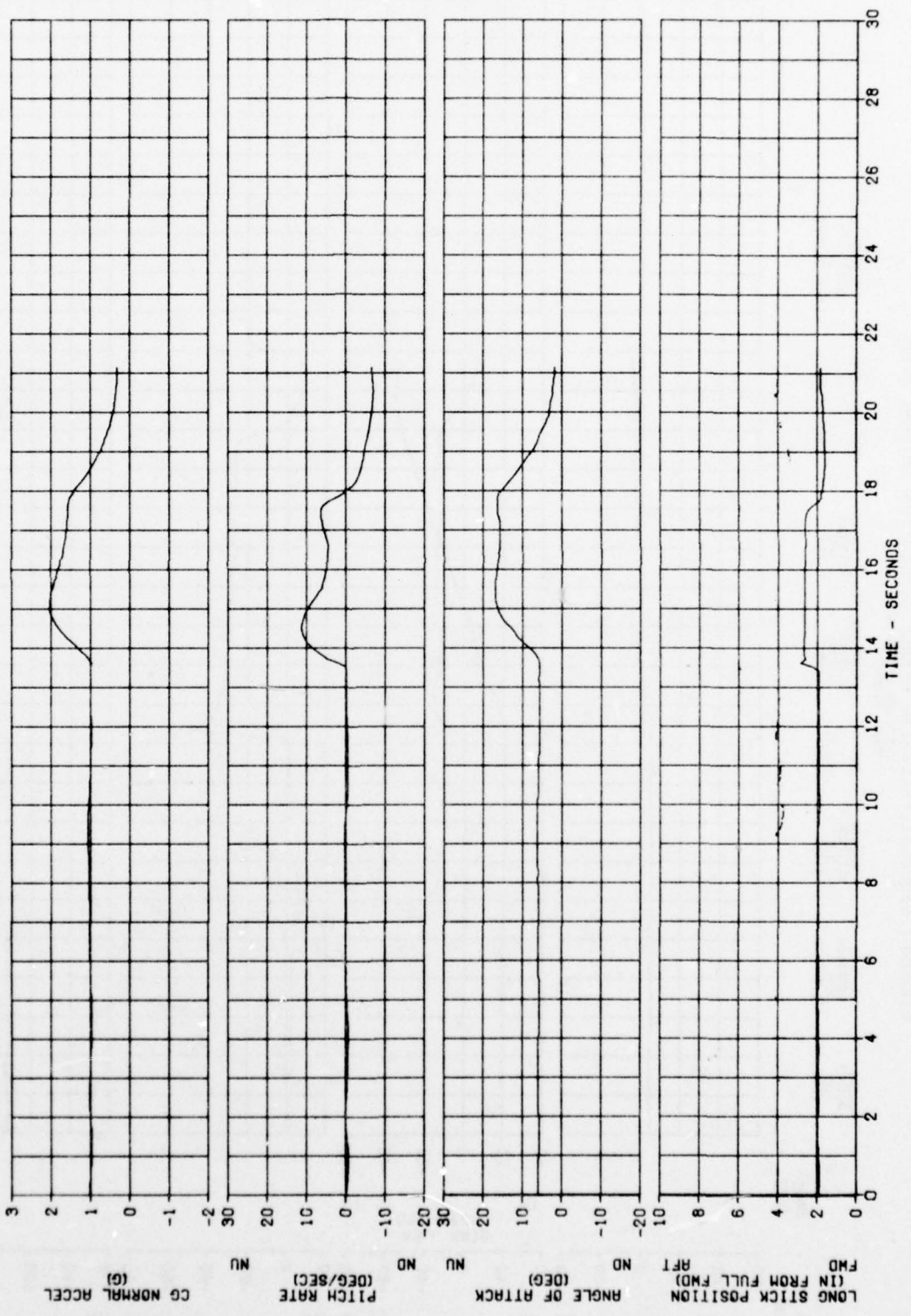

FIGURE 46
 AIRCRAFT RESPONSE FOLLOWING A HALF DEFLECTION LATERAL STEP
 U-21A USA S/N 88-18008
 BASIC AIRCRAFT

GROSS WEIGHT (LB) 9380
 LONG CG LOCATION (IN) 158.8 (AFT)
 DENSITY ALTITUDE (FT) 11660
 ORT (DEG C) 14.4
 PROPELLER SPEED (RPM) 2000
 TRIM AIRSPEED (KT) 120
 CONFIGURATION POWER APPROACH
 FLIGHT CONDITION LEVEL FLIGHT

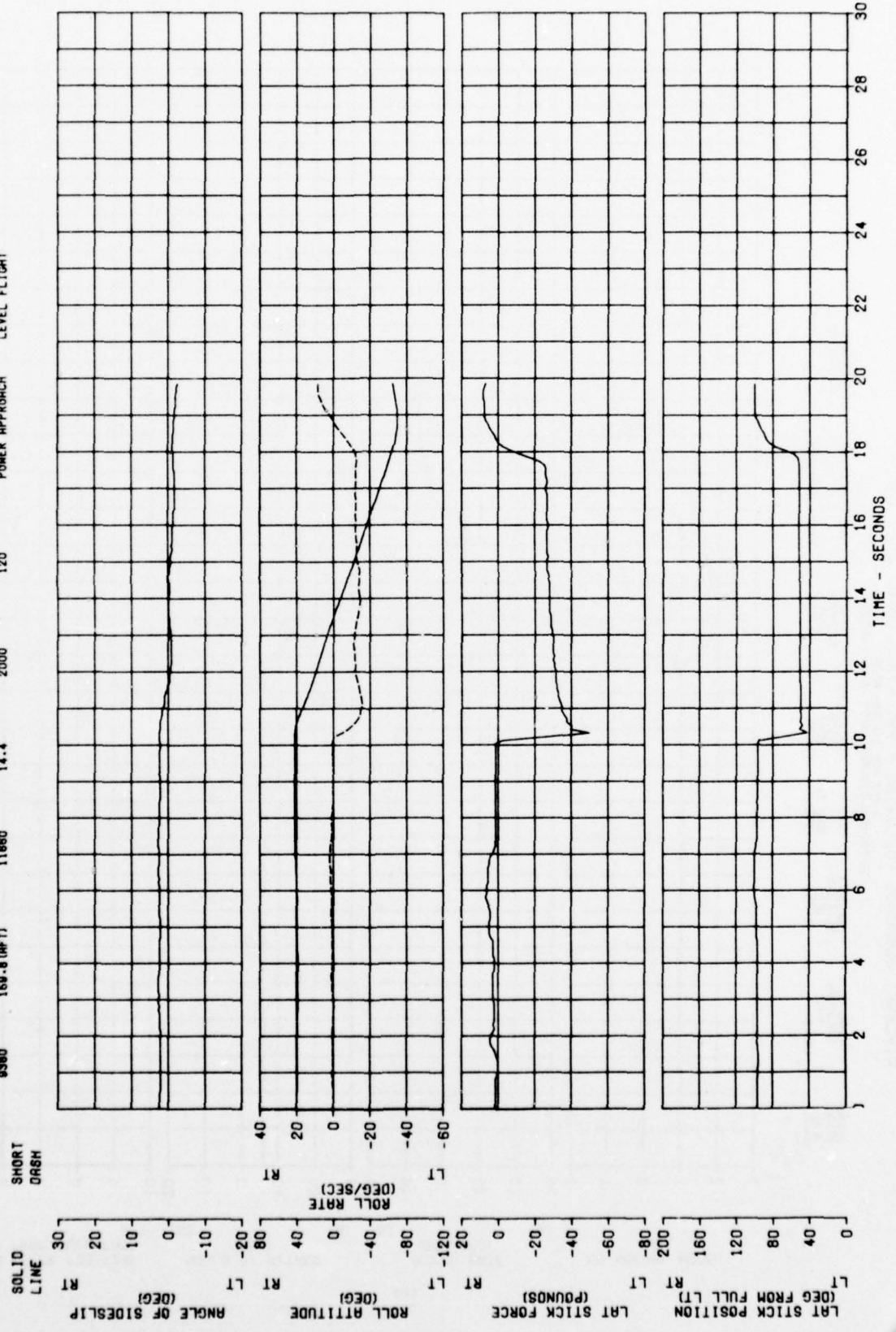

FIGURE 7
 AIRCRAFT RESPONSE FOLLOWING A HALF DEFLECTION LATERAL STEP

IR PRINTED AIRCRAFT WITH IR SUPPRESSORS

| | | | | | | | | | | | | | |
|-------------------|------|-----------------------|-------|-------------|-----|------------------------|------|--------------------|-----|---------------|----------------|------------------|--------------|
| CROSS HEIGHT (LB) | 8000 | DENSITY ALTITUDE (FT) | 11480 | ORF (DEG C) | 9.2 | PROPPELLER SPEED (RPM) | 2000 | TRIM AIRSPEED (KT) | 116 | CONFIGURATION | POWER APPROACH | FLIGHT CONDITION | LEVEL FLIGHT |
|-------------------|------|-----------------------|-------|-------------|-----|------------------------|------|--------------------|-----|---------------|----------------|------------------|--------------|

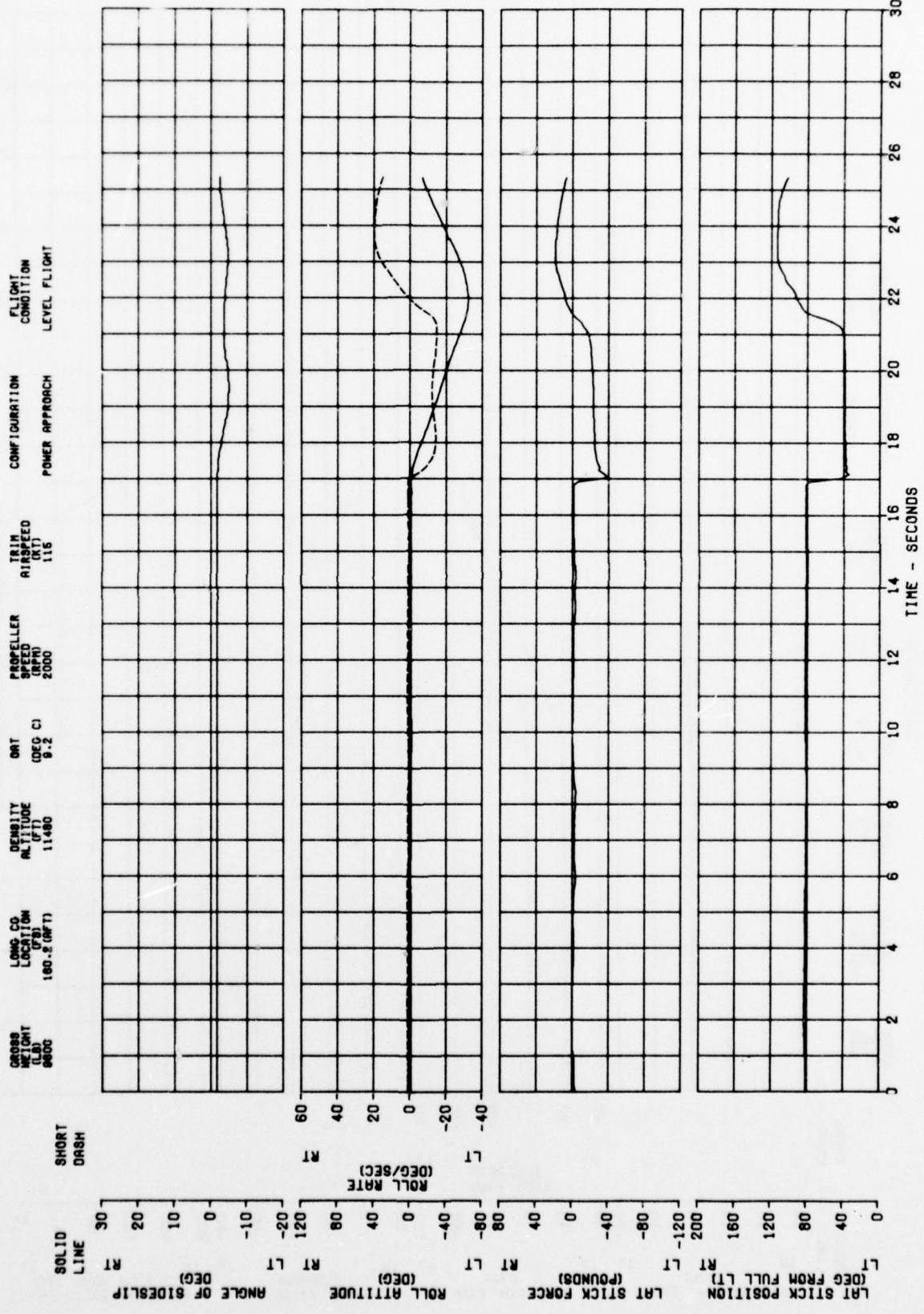

FIGURE 48
 AIRCRAFT RESPONSE FOLLOWING A HALF DEFLECTION LATERAL STEP
 U-21A USA S/N 86-18008
 BASIC AIRCRAFT

CROSS WEIGHT (LBS) 9000
 LONG CG POSITION (IN) 169.1 (AFT)
 DENSITY ALTITUDE (FT) 11600
 ORT (DEG C) 15.0
 PROPELLER RPM (RPM) 1900
 TRIM AIRSPEED (KTS) 142
 CONFIGURATION CRUISE
 FLIGHT CONDITION LEVEL FLIGHT

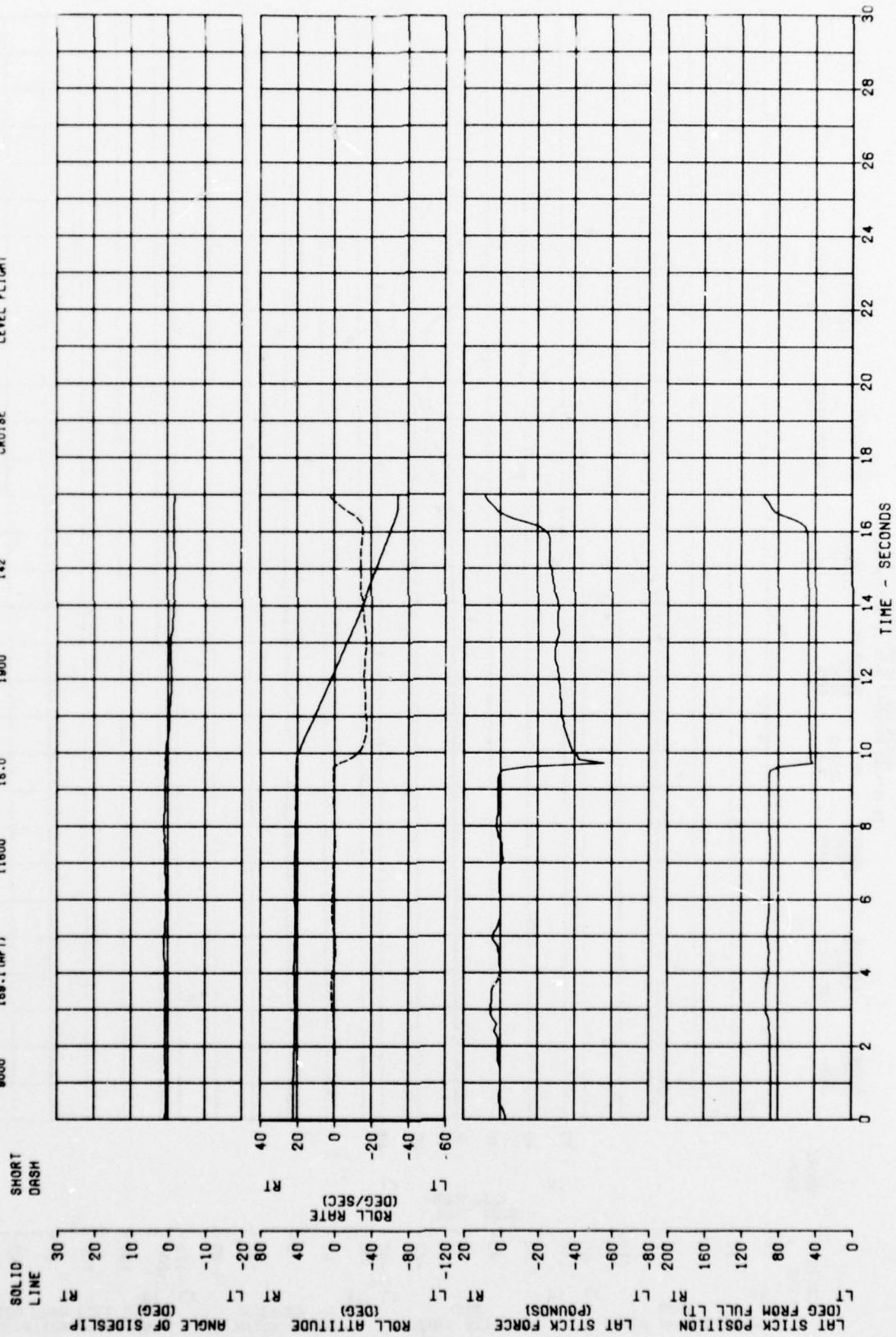

FIGURE 4?
 AIRCRAFT RESPONSE FOLLOWING A HALF DEFLECTION LATERAL STEP

IR PRINTED AIRCRAFT WITH IR SUPPRESSORS

GROSS WEIGHT (LBS) 8880
 LONG CO LOCATION (IN) 168.0 (WPT)
 DENSITY ALTITUDE (FT) 11420
 ORT (DEG. C) 7.2
 PROPELLER SPEED (RPM) 1800
 AIRSPEED (KT) 141
 CONFIGURATION POWER APPROACH
 FLIGHT CONDITION LEVEL FLIGHT

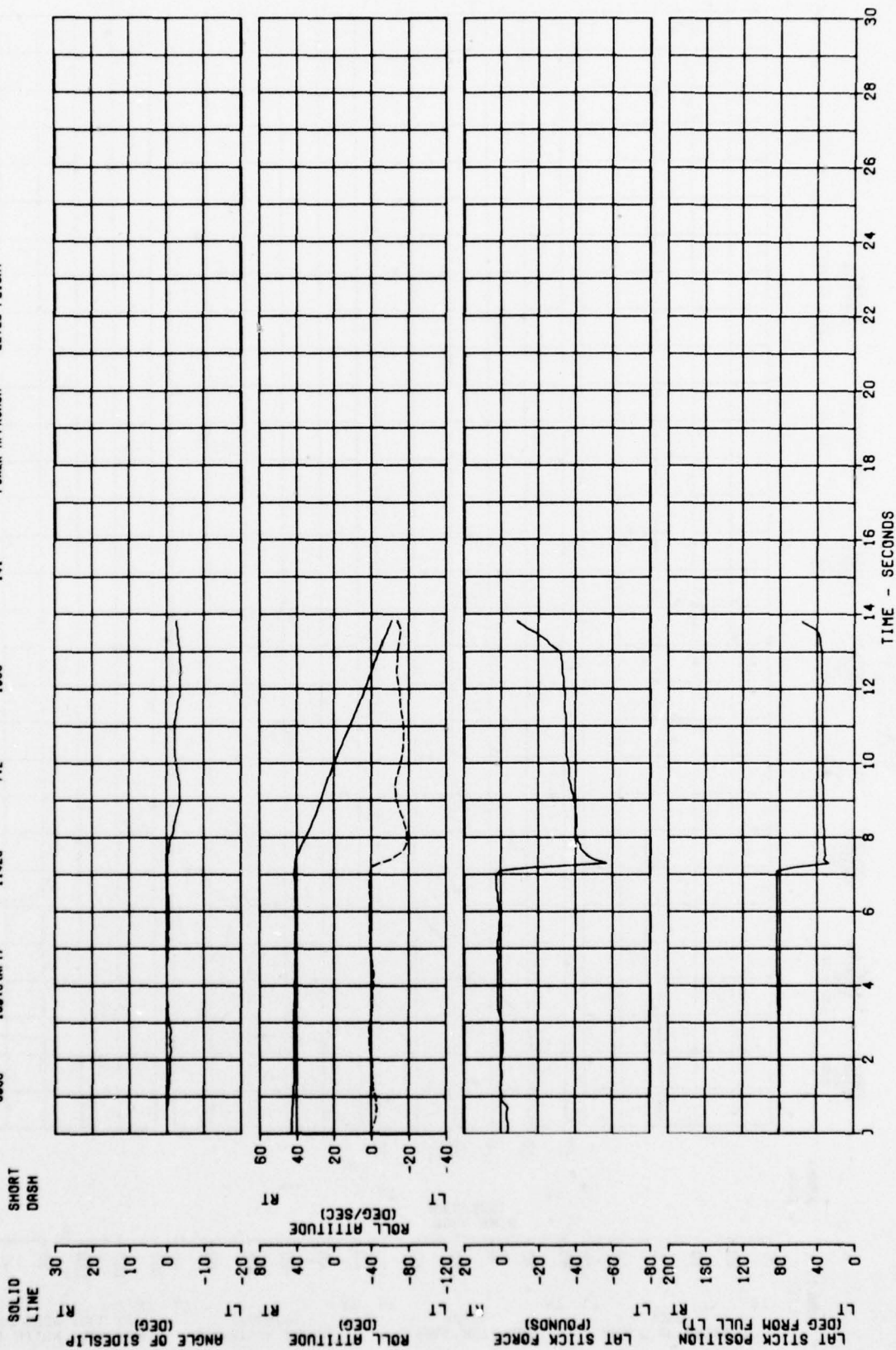

FIGURE 50
 AIRCRAFT RESPONSE FOLLOWING A FULL DEFLECTION LATERAL STEP
 U-21A USA S/N 66-10008
 BASIC AIRCRAFT

| | | | | | | | | | | | | | | | |
|--------------------|------|-----------------------|-------------|-----------------------|-------|-------------|------|-----------------------|------|---------------------|-----|---------------|--------|------------------|--------------|
| GROSS WEIGHT (LBS) | 8960 | LONG CG LOCATION (IN) | 189.1 (AFT) | DENSITY ALTITUDE (FT) | 11560 | ORT (DEG C) | 18.3 | PROPELLER SPEED (RPM) | 1900 | TRIM AIRSPEED (KTS) | 143 | CONFIGURATION | CRUISE | FLIGHT CONDITION | LEVEL FLIGHT |
|--------------------|------|-----------------------|-------------|-----------------------|-------|-------------|------|-----------------------|------|---------------------|-----|---------------|--------|------------------|--------------|

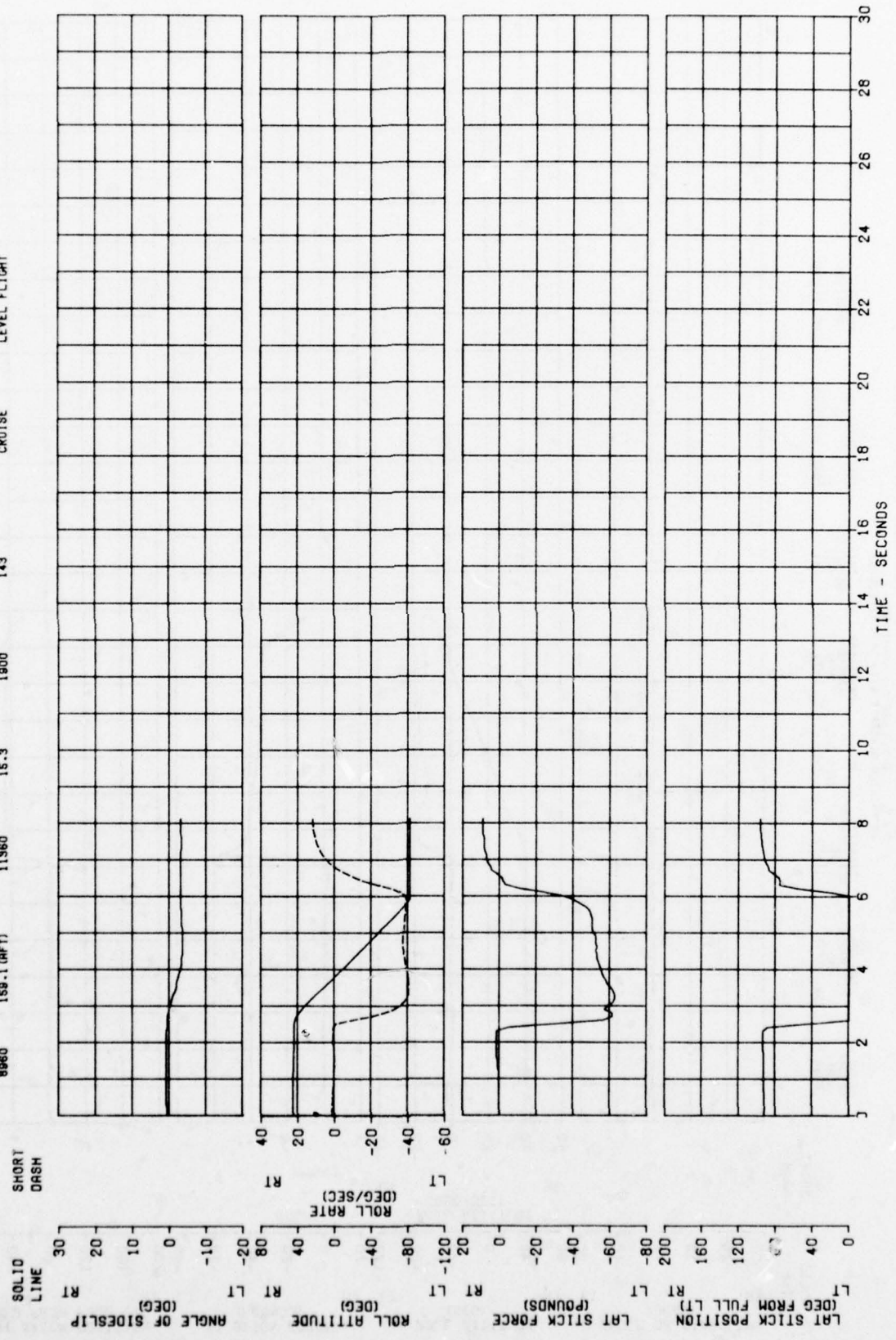
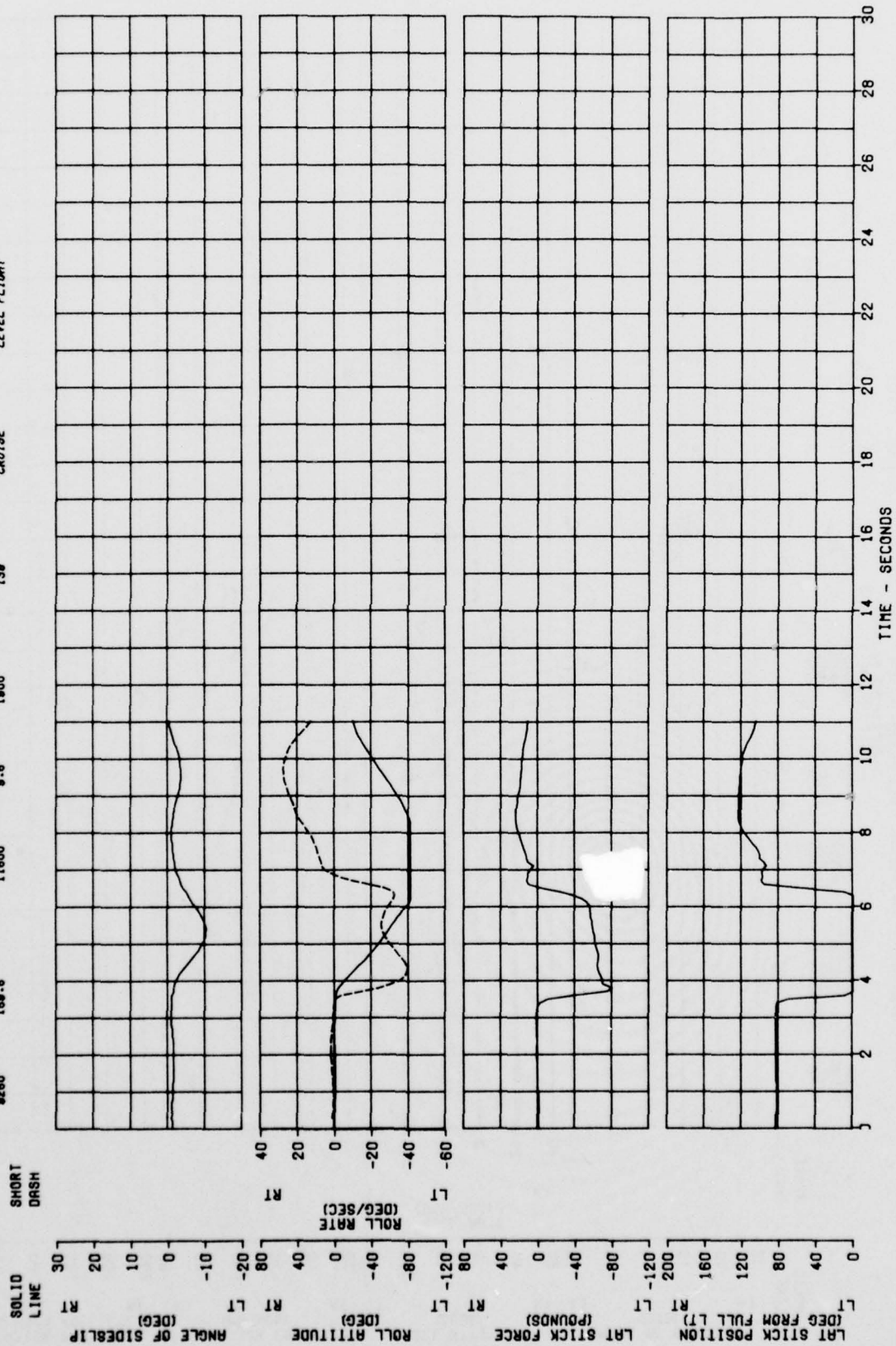

FIGURE 5/
AIRCRAFT RESPONSE FOLLOWING A FULL DEFLECTION LATERAL STEP

U-21A USA S/N 98-18000
IR PRINTED AIRCRAFT WITH IR SUPPRESSORS

| | | | | | | | | | | | | | | | |
|---------------------|------|-----------------------|-------|-----------------------|-------|-------------|-----|-----------------------|------|--------------------|-----|---------------|--------|------------------|--------------|
| GROSS WEIGHT (L.B.) | 8260 | LONG CO LOCATION (F#) | 169-6 | DENSITY ALTITUDE (FT) | 11000 | OAT (DEG C) | 9.6 | PROPELLER SPEED (RPM) | 1800 | TRIM AIRSPEED (KT) | 139 | CONFIGURATION | CRUISE | FLIGHT CONDITION | LEVEL FLIGHT |
|---------------------|------|-----------------------|-------|-----------------------|-------|-------------|-----|-----------------------|------|--------------------|-----|---------------|--------|------------------|--------------|



AIRCRAFT RESPONSE FOLLOWING A HALF DEFLECTION LATERAL STEP

FIGURE 52
U-21A UBR 87N 86-18008
BASIC AIRCRAFT

| | | | | | | | | | | | | | | | |
|-------------------|------|-----------------------|-------------|-----------------------|-------|-------------|------|-----------------------|------|--------------------|-----|---------------|--------|------------------|--------------|
| CROSS HEIGHT (LB) | 6700 | LONG CG LOCATION (IN) | 168.6 (AFT) | DENSITY ALTITUDE (FT) | 12080 | ORT (DEG C) | 13.8 | PROPELLER SPEED (RPM) | 1900 | TRIM AIRSPEED (KT) | 161 | CONFIGURATION | CRUISE | FLIGHT CONDITION | LEVEL FLIGHT |
|-------------------|------|-----------------------|-------------|-----------------------|-------|-------------|------|-----------------------|------|--------------------|-----|---------------|--------|------------------|--------------|

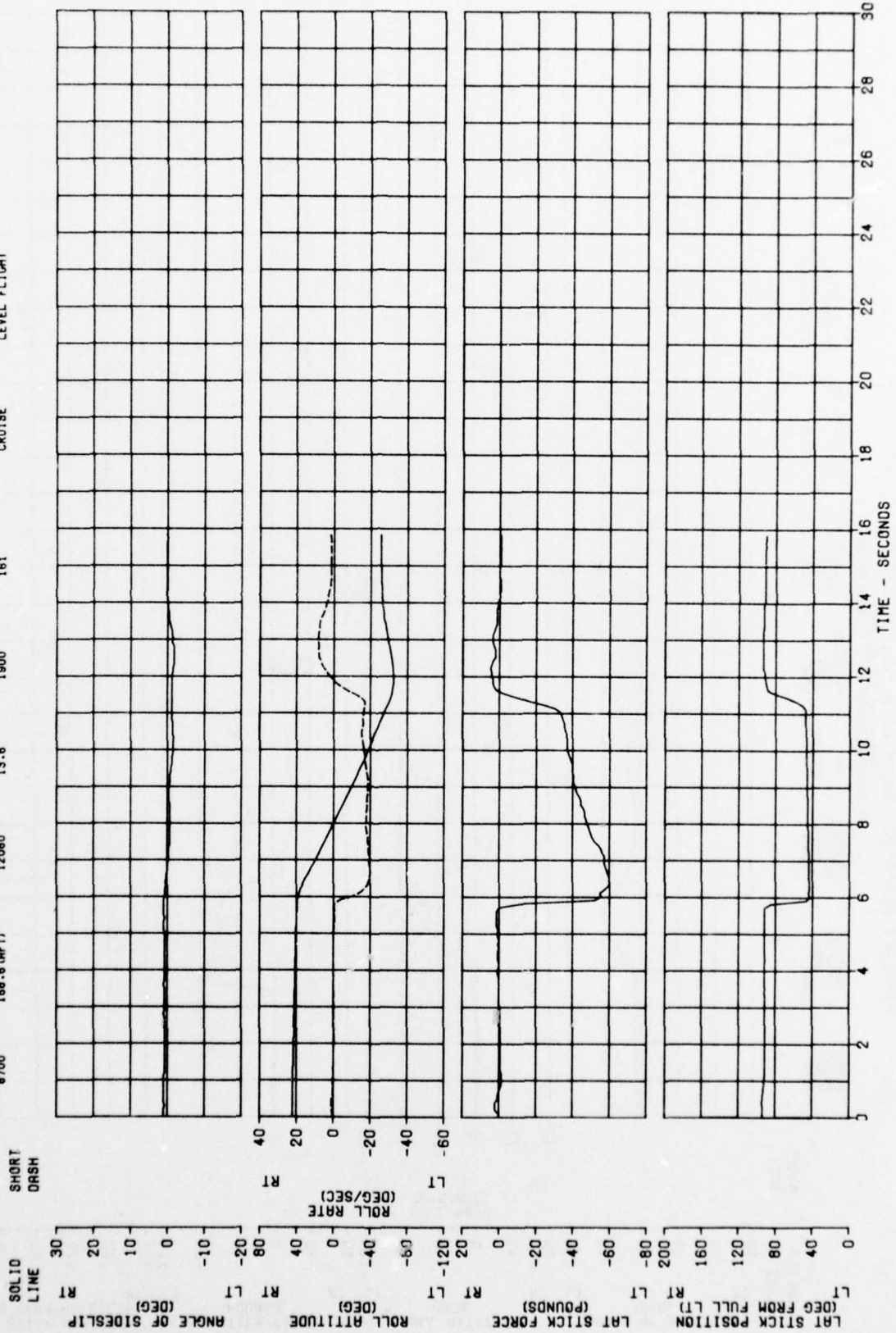

FIGURE 5-3
 AIRCRAFT RESPONSE FOLLOWING A HALF DEFLECTION LATERAL STEP

U-21A USAF S/N 86-18006
 IR PRINTED AIRCRAFT WITH IR SUPPRESSORS

| | | | | | | | | | | | | | | | |
|-------------------|------|-----------------------|-------------|-----------------------|-------|-------------|-----|-----------------------|------|--------------------|-----|---------------|--------|------------------|--------------|
| GROSS WEIGHT (LB) | 8750 | LONG CG LOCATION (IN) | 158.6 (AFT) | DENSITY ALTITUDE (FT) | 11390 | ORT (DEG C) | 7.4 | PROPELLER SPEED (RPM) | 1900 | TRIM AIRSPEED (KT) | 162 | CONFIGURATION | CRUISE | FLIGHT CONDITION | LEVEL FLIGHT |
|-------------------|------|-----------------------|-------------|-----------------------|-------|-------------|-----|-----------------------|------|--------------------|-----|---------------|--------|------------------|--------------|

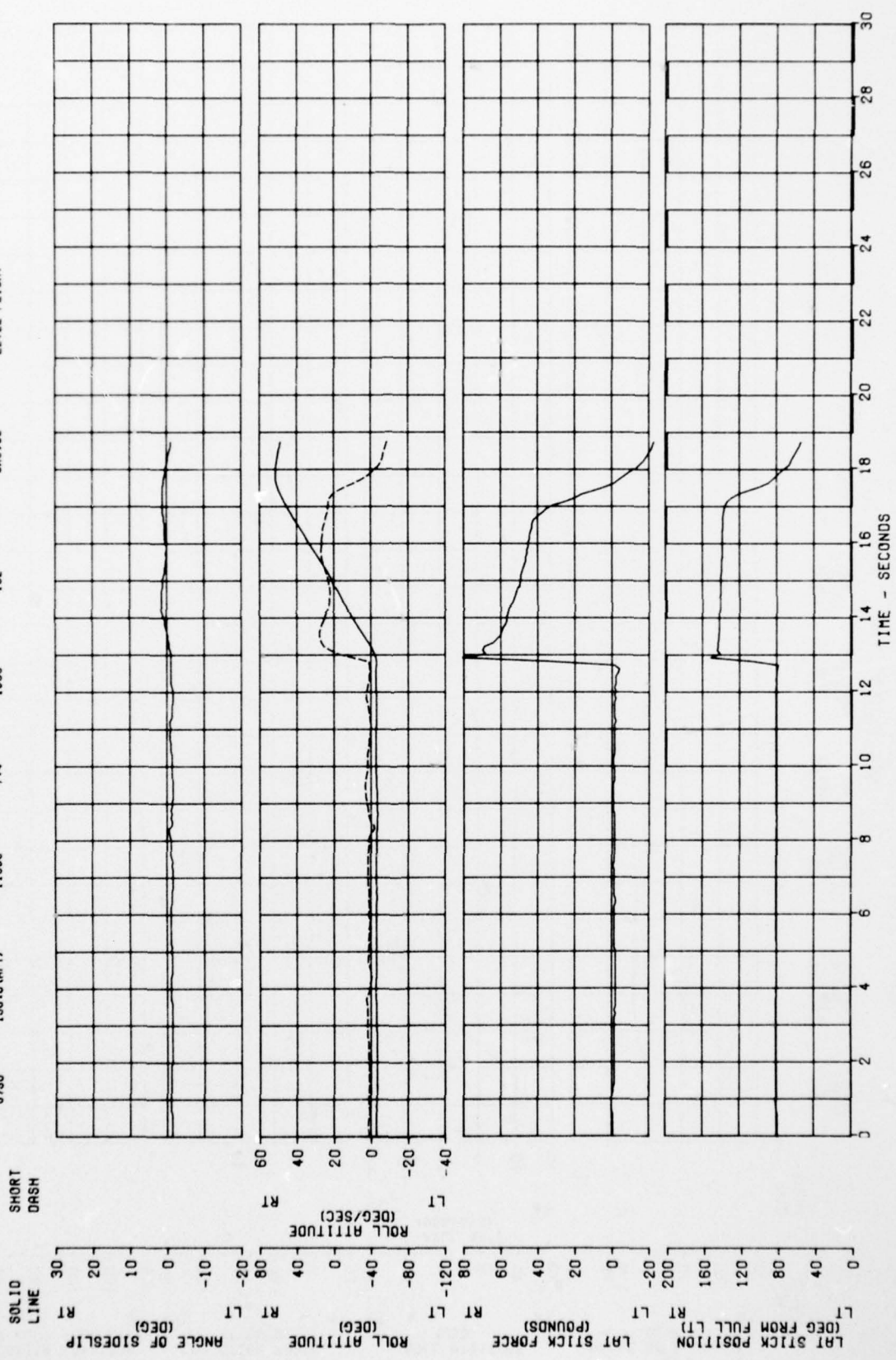

FIGURE 3-4
 AIRCRAFT RESPONSE FOLLOWING A FULL DEFLECTION LATERAL STEP

U-21A USA S/N 68-19008
 BASIC AIRCRAFT

FLIGHT
 CONDITION
 LEVEL FLIGHT

CONFIGURATION
 CRUISE

TRIM
 AIRSPEED
 161

PROPELLER
 SPEED
 1900

DRT
 (DEG C)
 14.7

DENSITY
 ALTITUDE
 11450

LONG CG
 LOCATION
 158.5 (AFT)

GROSS
 WEIGHT
 6670

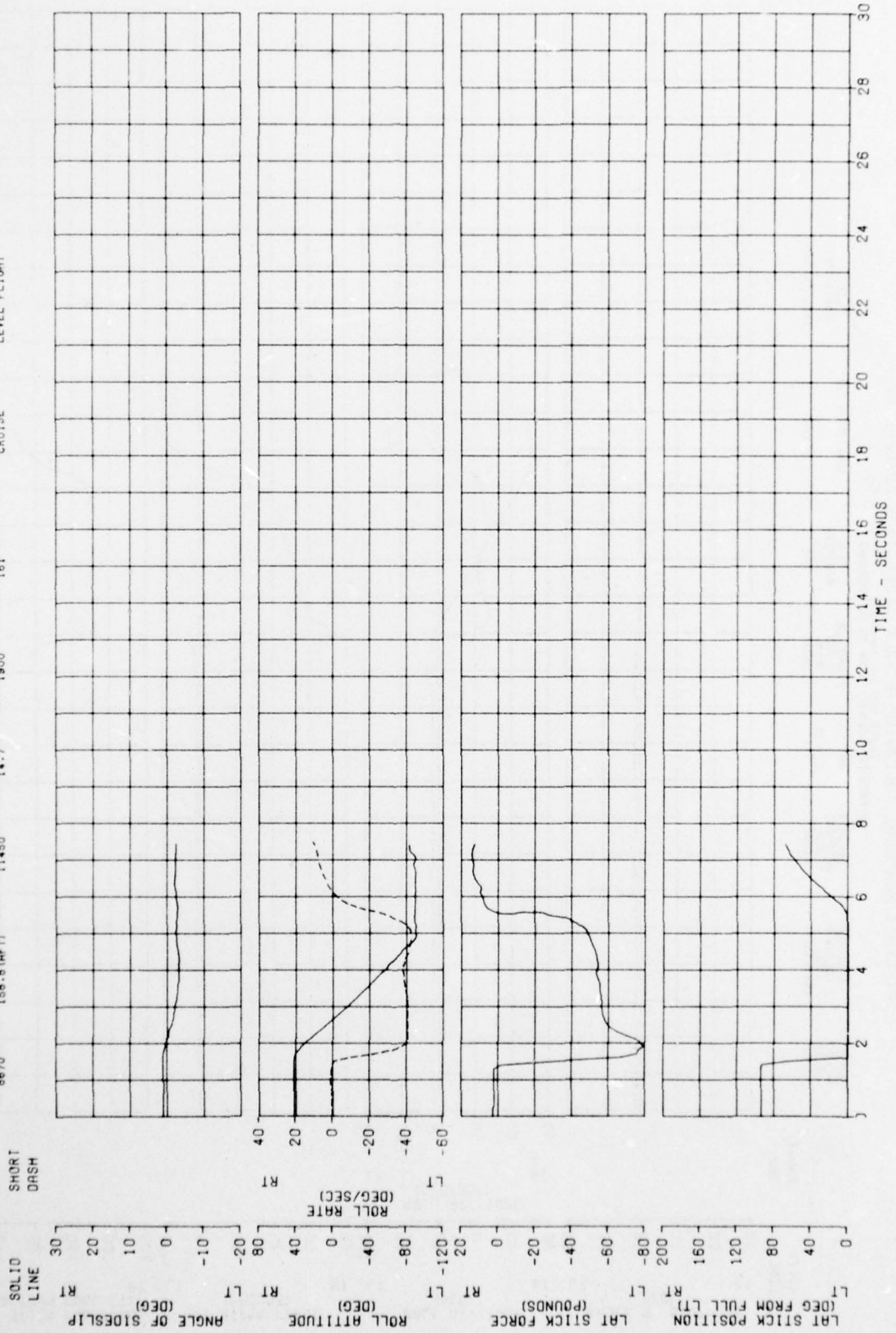

FIGURE 55
 AIRCRAFT RESPONSE FOLLOWING A FULL DEFLECTION LATERAL STEP

U-21A USA S/N 66-18008
 IR PRINTED AIRCRAFT WITH IR SUPPRESSORS

| | | | | | | | | | | | | | | | |
|--------------------|------|-----------------------|-------------|-----------------------|-------|-------------|-----|-----------------------|------|--------------------|-----|---------------|--------|------------------|--------------|
| CROSS WEIGHT (LBS) | 8740 | LONG CG LOCATION (IN) | 168.6 (aft) | DENSITY ALTITUDE (FT) | 11400 | ORF (DEG C) | 7.3 | PROPELLER SPEED (RPM) | 1900 | TRIM AIRSPEED (KT) | 161 | CONFIGURATION | CRUISE | FLIGHT CONDITION | LEVEL FLIGHT |
|--------------------|------|-----------------------|-------------|-----------------------|-------|-------------|-----|-----------------------|------|--------------------|-----|---------------|--------|------------------|--------------|

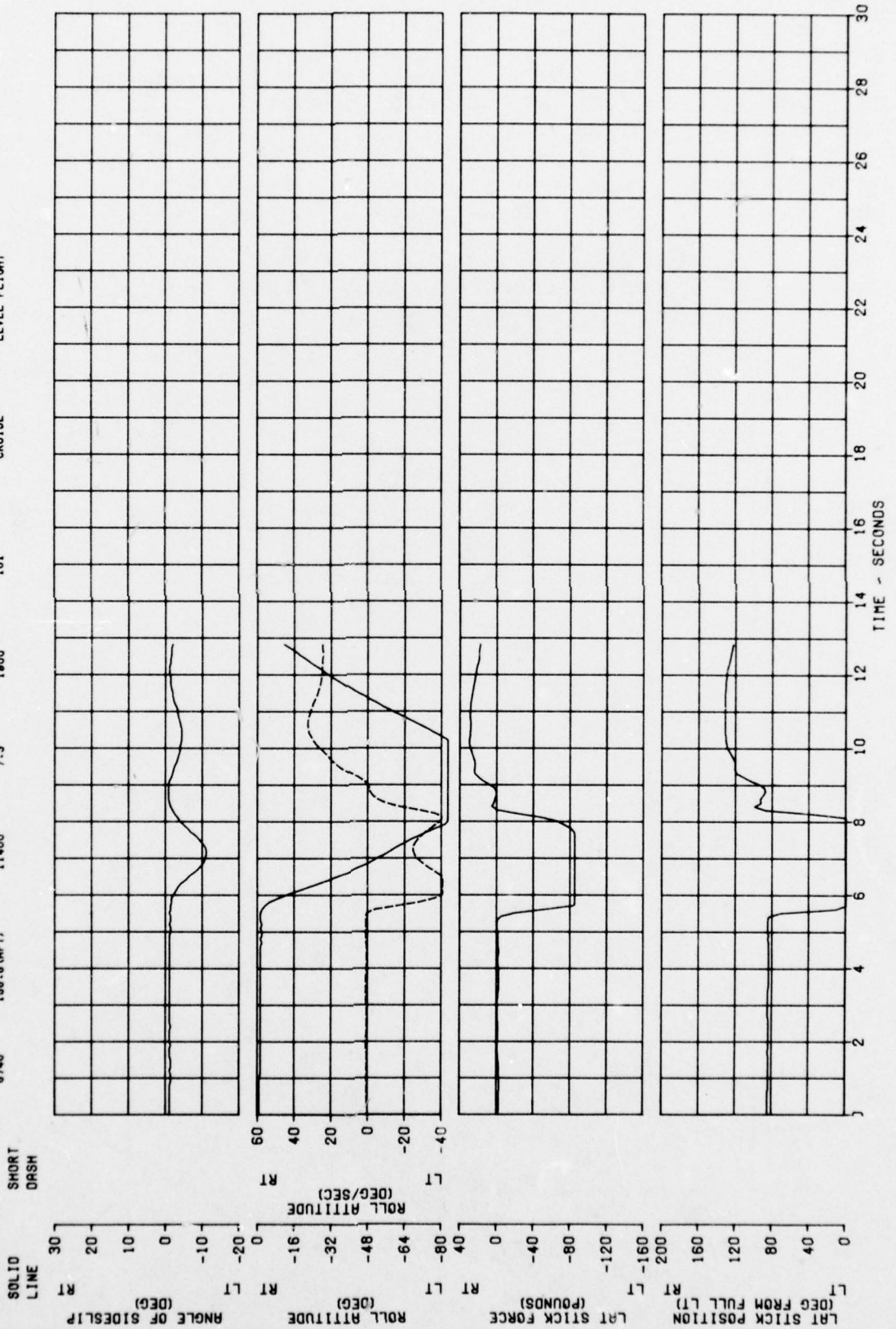

FIGURE 56
ROLL PERFORMANCE
U-21A USA S/N 66-18008

| AVG GROSS WEIGHT ~LB | AVG LONG CG LOCATION ~FS | AVG DENSITY ALTITUDE ~FT | AVG OAT ~°C | TRIM AIRSPEED ~KCAS | PROPELLER SPEED ~RPM | CONFIGURATION | FLIGHT CONDITION |
|-------------------------|-----------------------------|-----------------------------|----------------|------------------------|-------------------------|---------------|------------------|
| 8920 | 159.0 (AFT) | 12400 | 12.0 | 160,140,120 | 1900 | CR, PA | LEVEL FLIGHT |
| 8980 | 159.0 (AFT) | 11260 | 8.0 | 160,140,120 | 1900 | CR, PA | LEVEL FLIGHT |

- BASIC AIRCRAFT
- IR PAINTED AIRCRAFT WITH IR SUPPRESSORS

NOTE: FULL AILERON DEFLECTION.

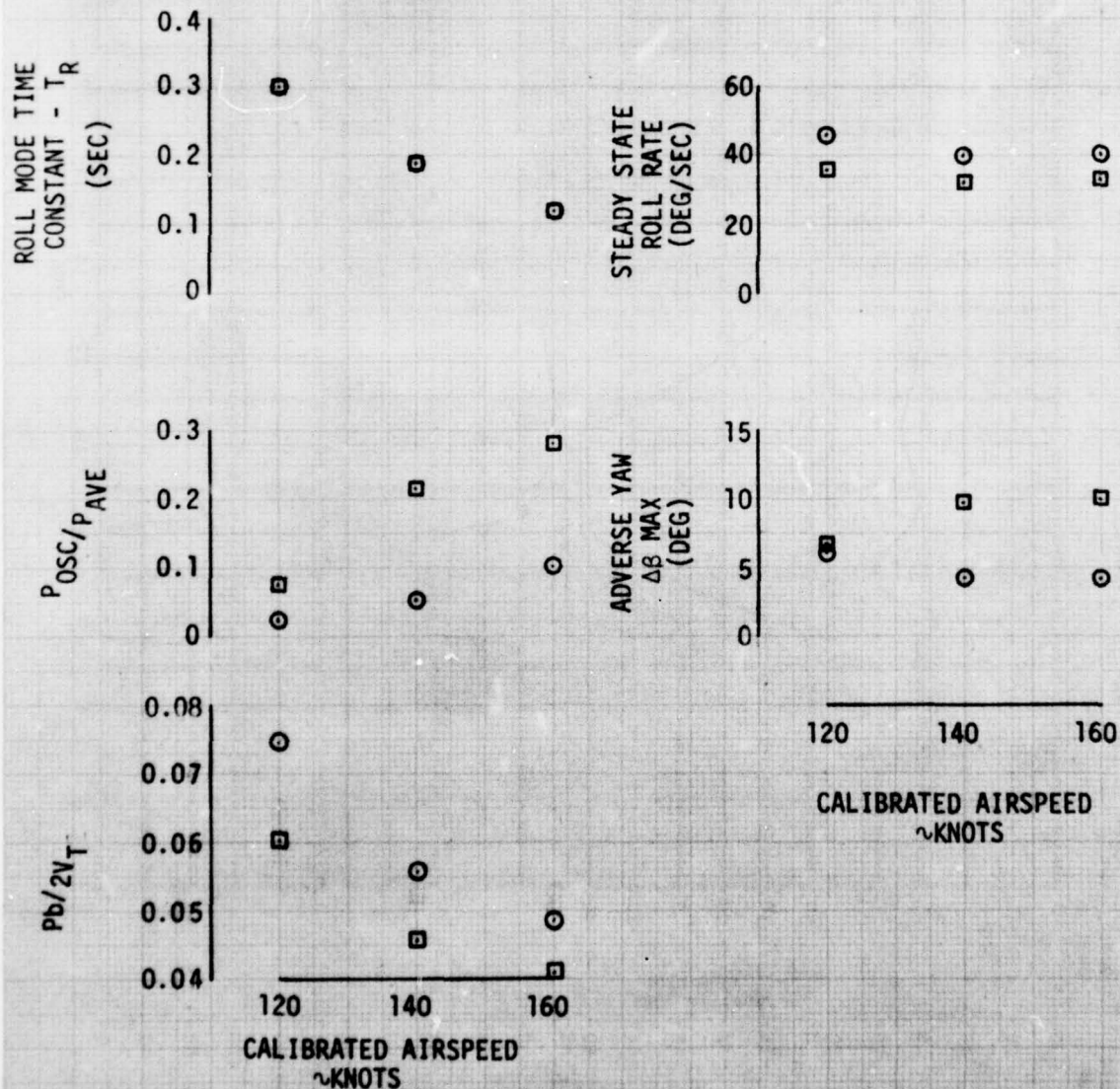

FIGURE 57
 MINIMUM SINGLE ENGINE CONTROL
 AIRSPEED VARIATION WITH ALTITUDE
 U21-A USA S/N 66-18008

| SYMBOL | AVG GROSS WEIGHT ~ LB | AVG LONG CG LOCATION ~ FS | PROPELLER SPEED ~ RPM | CONFIGURATION | FLIGHT CONDITION |
|--------|--------------------------|------------------------------|--------------------------|---------------|------------------|
| ○ | 8100 | 152.0(MID) | 1900 | CRUISE | CLIMB |
| △ | 7990 | 152.0(MID) | 2200 | TAKEOFF | CLIMB |
| □ | 7820 | 151.5(MID) | 2200 | WAVEOFF | CLIMB |

———— STATIC V_{MC}
 - - - - DYNAMIC V_{MC}

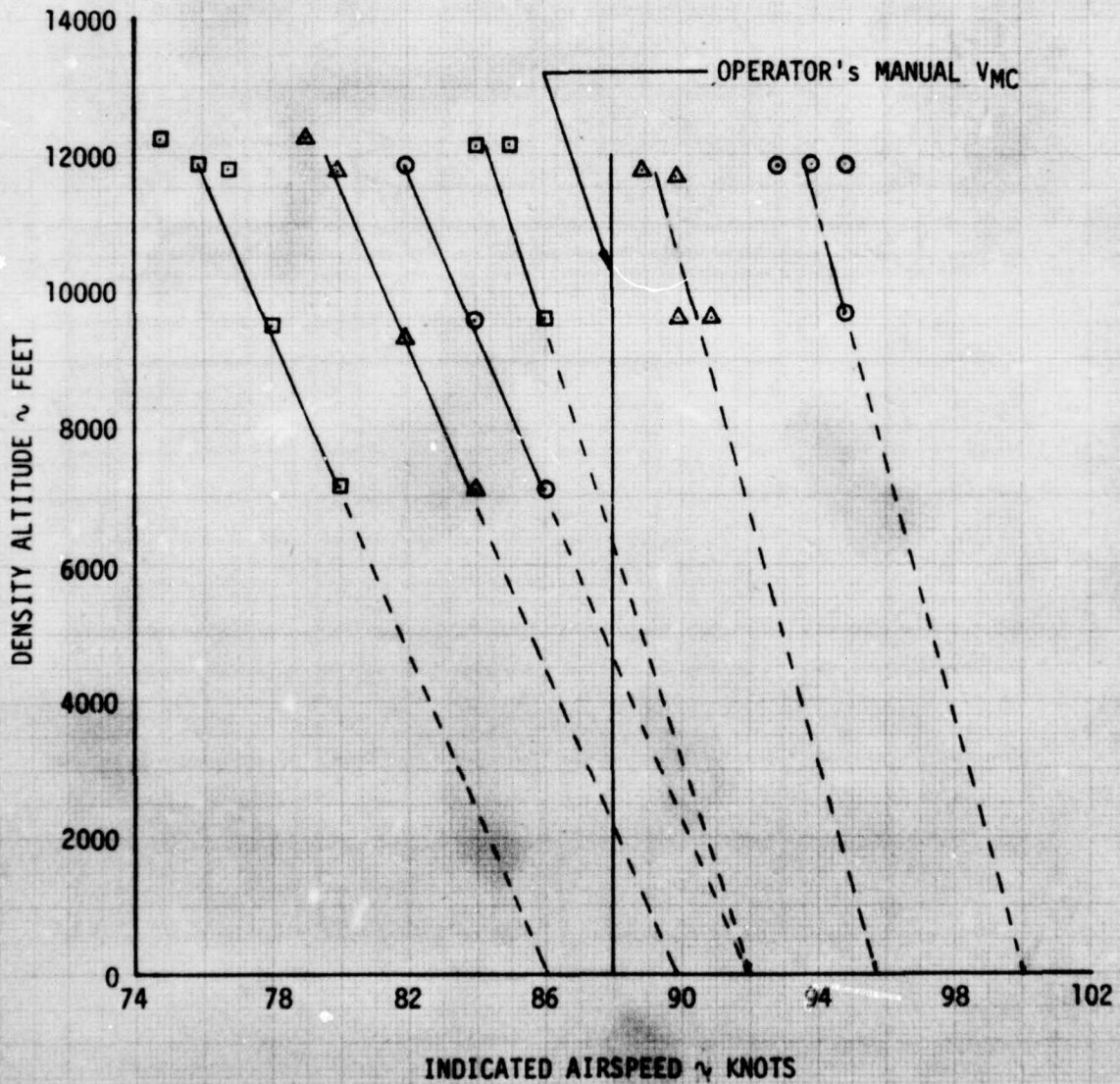

FIGURE 58
 TAKEOFF PERFORMANCE - 85 KIAS LIFTOFF

U-21A USA S/N 66-18008
 IR PAINTED AIRCRAFT WITH IR SUPPRESSORS

| | | | | | | | | | |
|------------------------|-------|-----------------------|------|-------------|------|-----------------------|------|---------------|---------|
| GROSS WEIGHT (LBS) | 8610 | DENSITY ALTITUDE (FT) | 3750 | ORT (DEG C) | 24.1 | PROPELLER SPEED (RPM) | 2200 | CONFIGURATION | TAKEOFF |
| LONG CG LOCATION (FWD) | 153.6 | | | | | | | | |

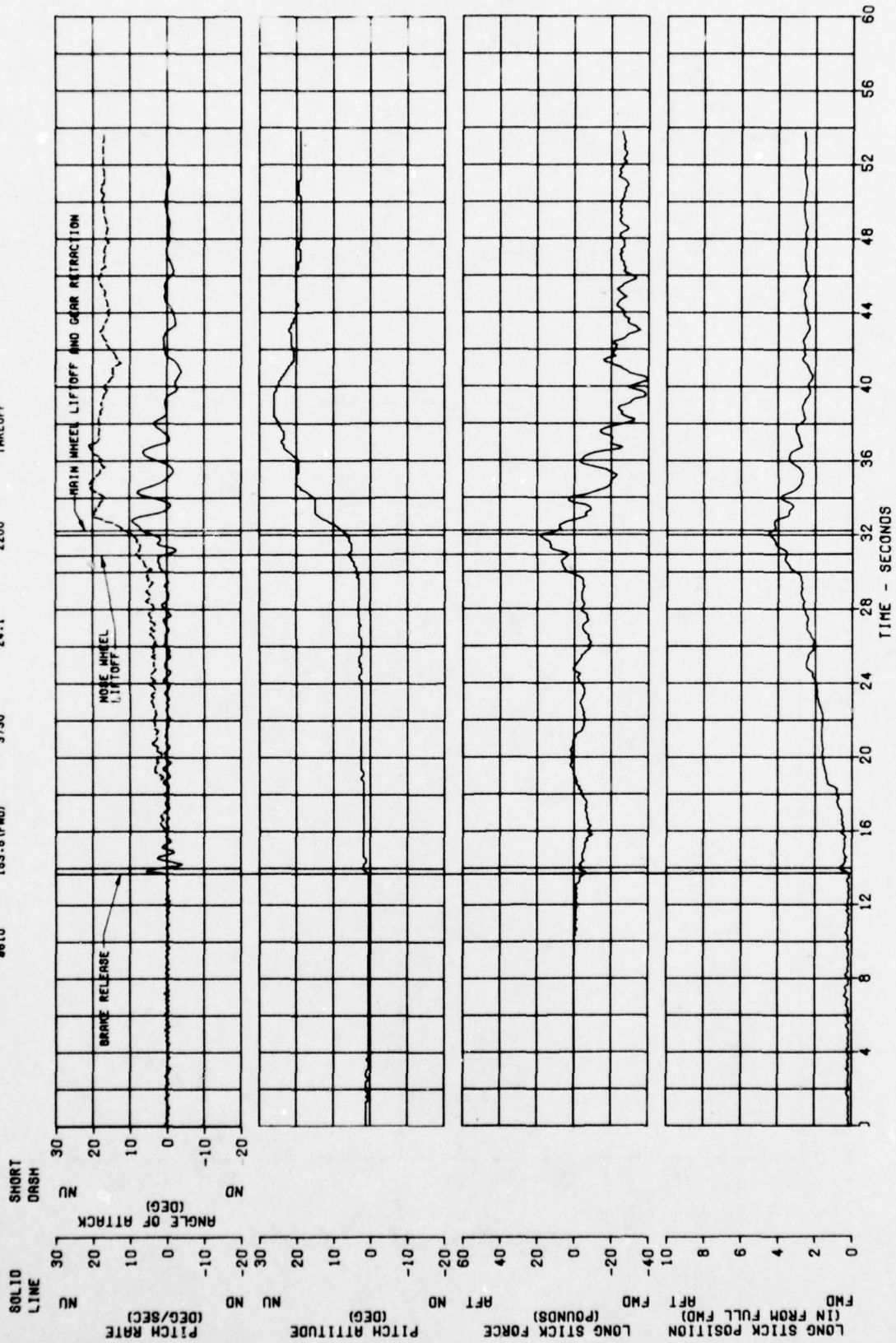

FIGURE 59
 TAKEOFF PERFORMANCE -- 95 KIAS LIFTOFF

U-219 USA S/N 66-11008
 IR PRINTED AIRCRAFT WITH IR SUPPRESSORS

| | | | | | | | |
|-----------------------|-------------|-----------------------|------|------------------------|------|---------------|---------|
| GROSS WEIGHT (LBS) | 9610 | DENSITY ALTITUDE (FT) | 3610 | PROPPELLER SPEED (RPM) | 2200 | CONFIGURATION | TAKEOFF |
| LONG CG LOCATION (F8) | 153.5 (FWD) | ORF (DEG C) | 23.0 | | | | |

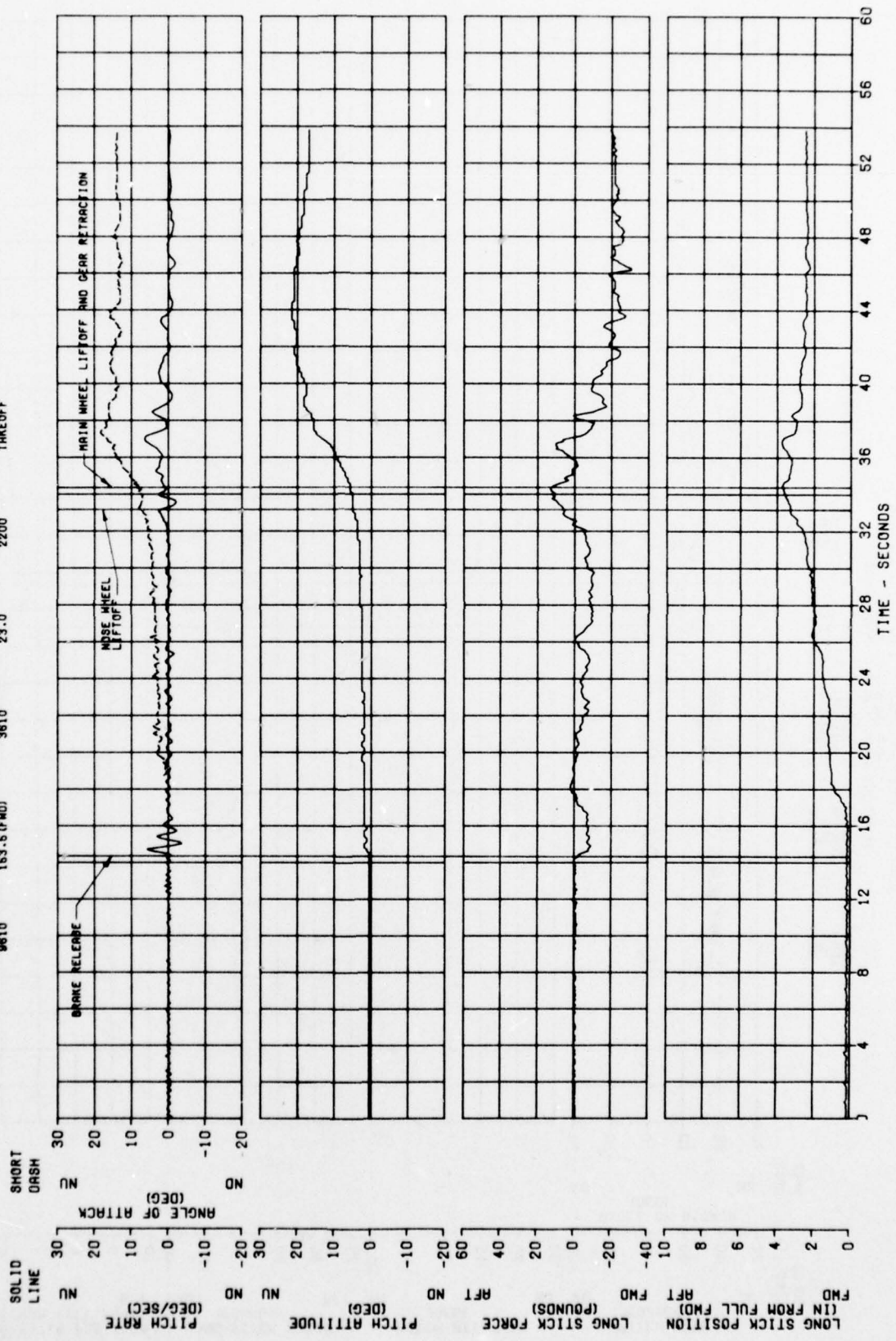

FIGURE 60
 TAKEOFF PERFORMANCE - 100 KIAS LIFTOFF

U-21A USA S/N 86-18009
 JR PAINTED AIRCRAFT WITH IR SUPPRESSORS

| | | | | | | | |
|-----------------------|-------------|-----------------------|------|------------------------|------|---------------|---------|
| GROSS WEIGHT (LB) | 9610 | DENSITY ALTITUDE (FT) | 3430 | PROPPELLER SPEED (RPM) | 2200 | CONFIGURATION | TAKEOFF |
| LONG CO LOCATION (FS) | 189.6 (FWD) | OAT (DEG C) | 21.4 | | | | |

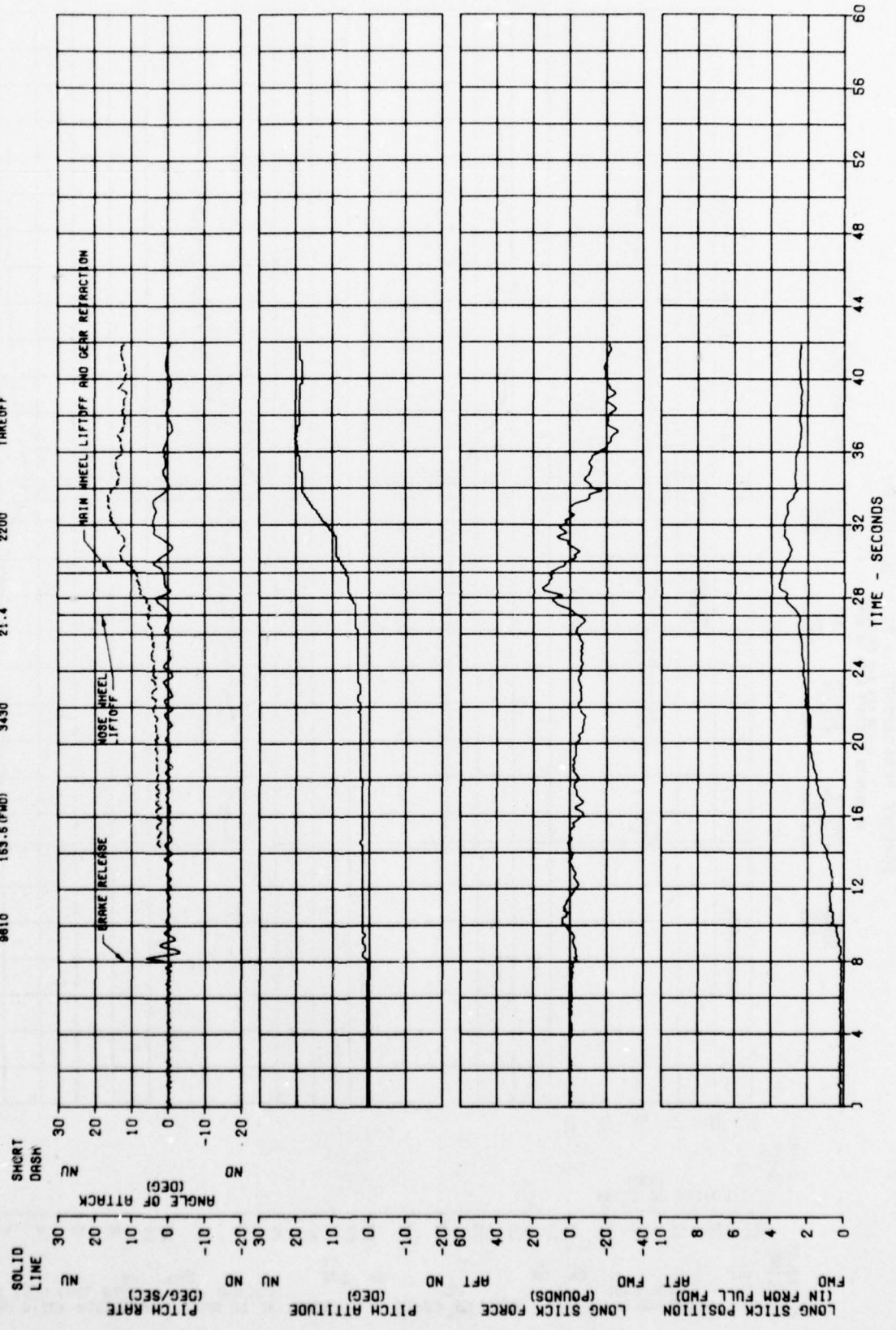

FIGURE 61
REFERRED ENGINE CHARACTERISTICS
U-21A USA S/N 66-18008

- NOTES: 1. STATIC GROUND RUN
2. NO. 2 ENGINE S/N PC-E-21153
3. PROP SPEED - 1900 RPM
4. ○ BASIC AIRCRAFT
5. □ IR PAINTED AIRCRAFT WITH IR SUPPRESSORS
6. ZERO AIR BLEED AND ANTI-ICE OFF

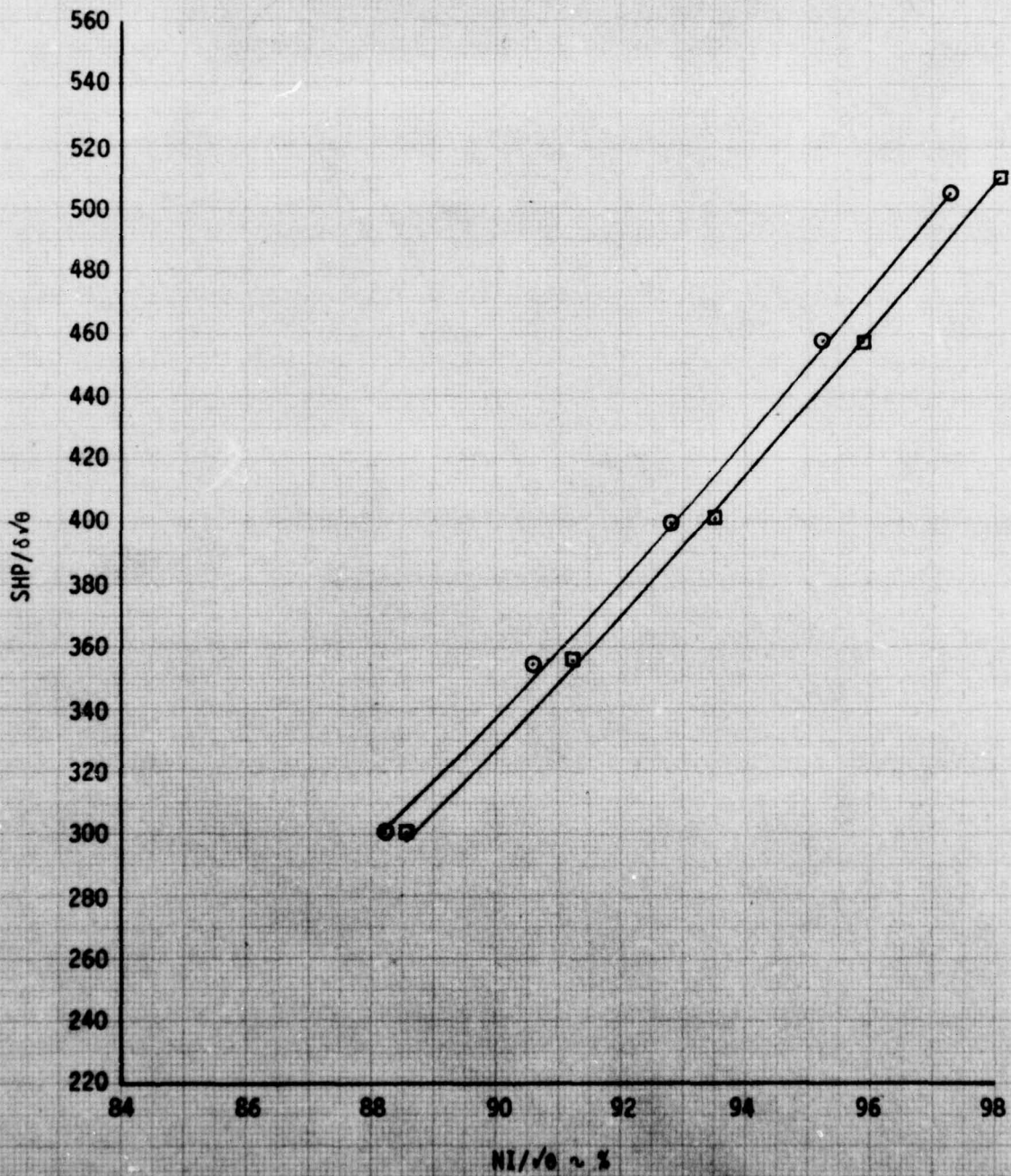

FIGURE 62
REFERRED ENGINE CHARACTERISTICS
U-21A USA S/N 66-18008

- NOTES: 1. STATIC GROUND RUN
2. NO. 2 ENGINE S/N PC-E-21153
3. PROP SPEED - 1900 RPM
4. ○ BASIC AIRCRAFT
5. □ IR PAINTED AIRCRAFT WITH IR SUPPRESSORS
6. ZERO AIR BLEED AND ANTI-ICE OFF

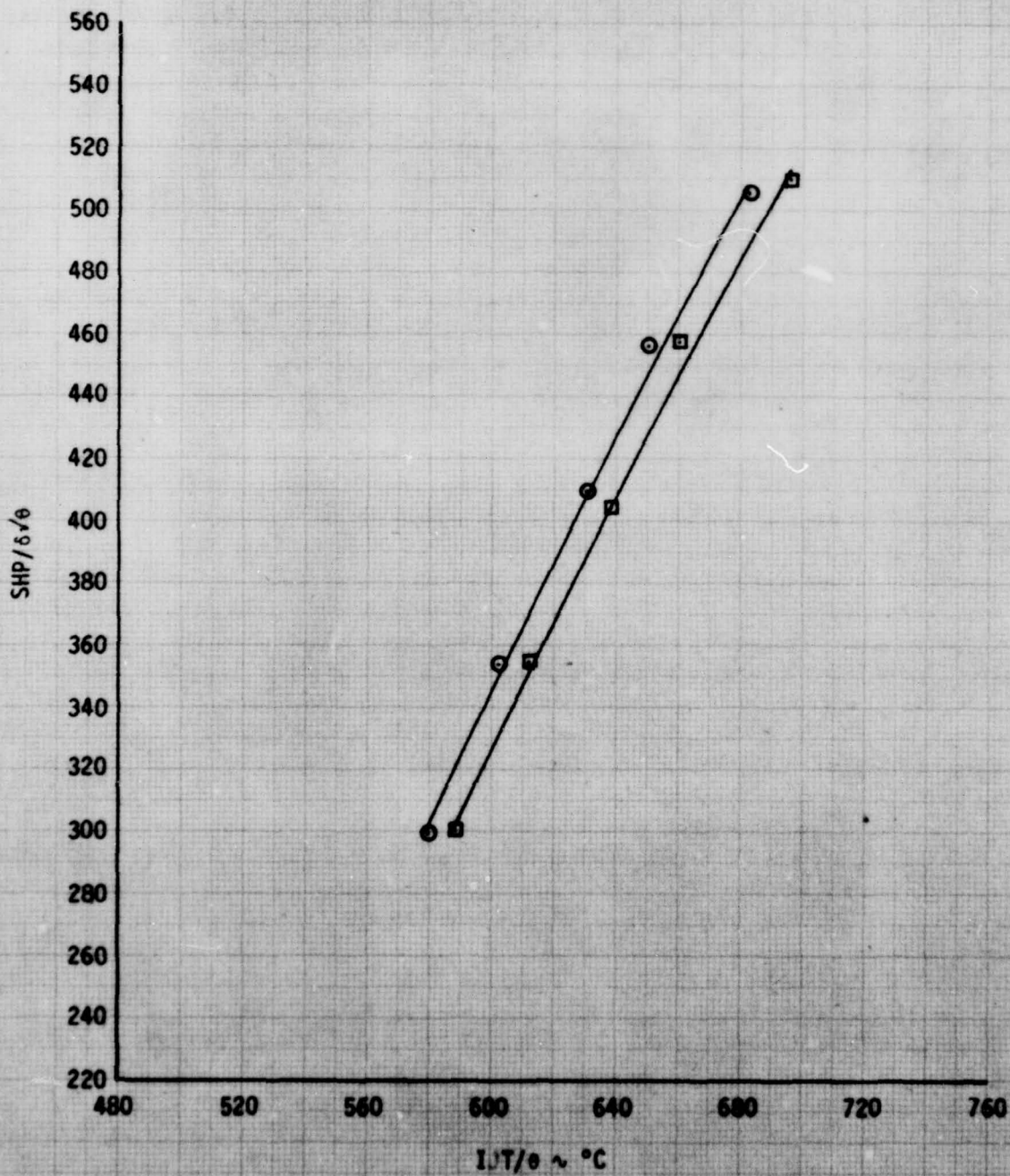

FIGURE 63
 REFERRED ENGINE CHARACTERISTICS
 U-21A USA S/N 66-18008

- NOTES: 1. LEVEL FLIGHT
 2. NO. 2 ENGINE S/N PC-E-21153
 3. PROPELLER SPEED = 1900 RPM
 4. ○ BASIC AIRCRAFT
 5. □ IR PAINTED AIRCRAFT WITH IR SUPPRESSORS
 6. ZERO AIR BLEED AND ANTI-ICE OFF

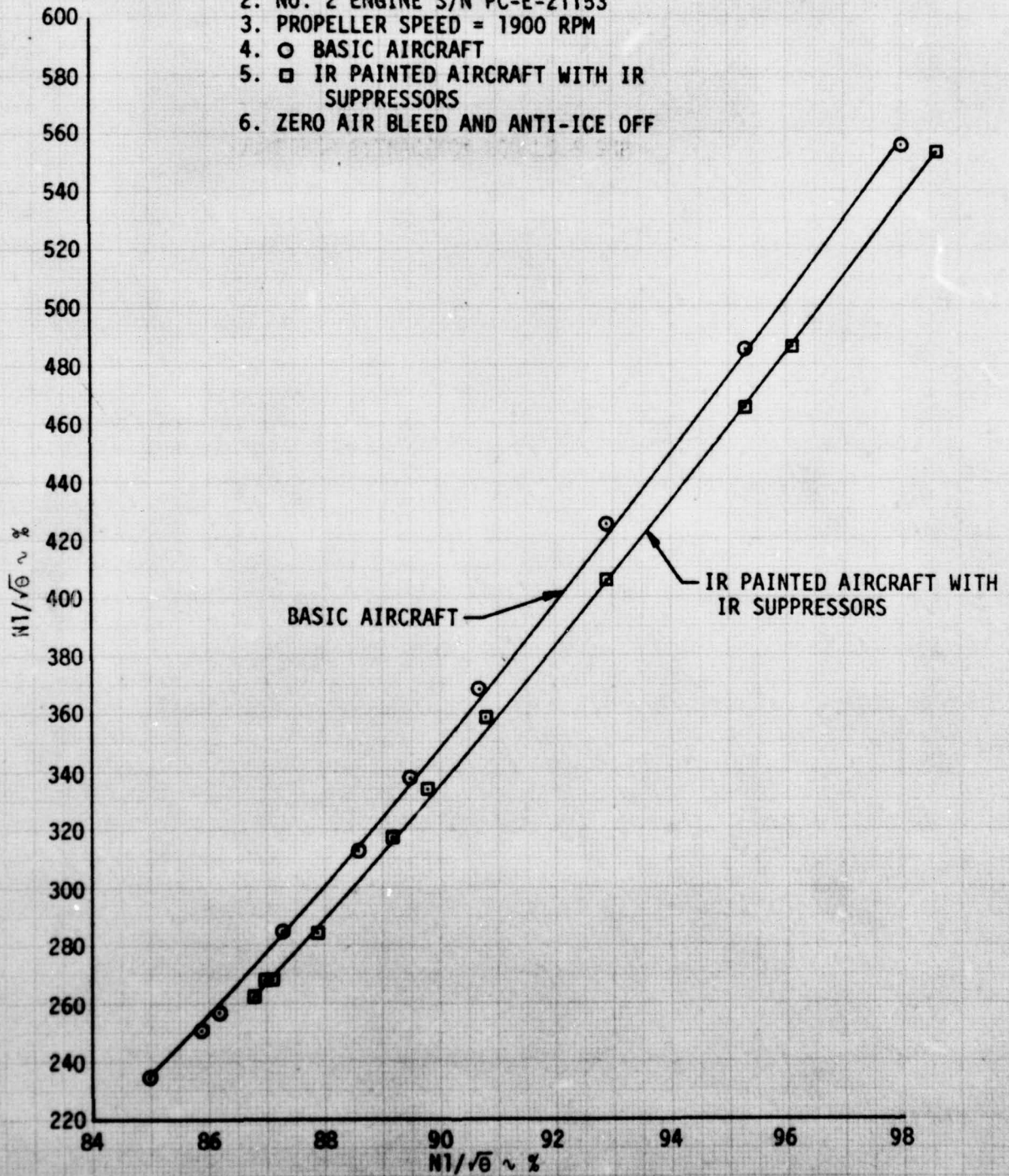

FIGURE 64
 REFERRED ENGINE CHARACTERISTICS
 U-21A USA S/N 66-18008

- NOTES: 1. LEVEL FLIGHT
 2. NO. 2 ENGINE S/N PC-E-21153
 3. PROPELLER SPEED - 1900 RPM
 4. ○ BASIC AIRCRAFT
 5. □ IR PAINTED AIRCRAFT WITH IR SUPPRESSORS
 6. ZERO AIR BLEED AND ANTI-ICE OFF

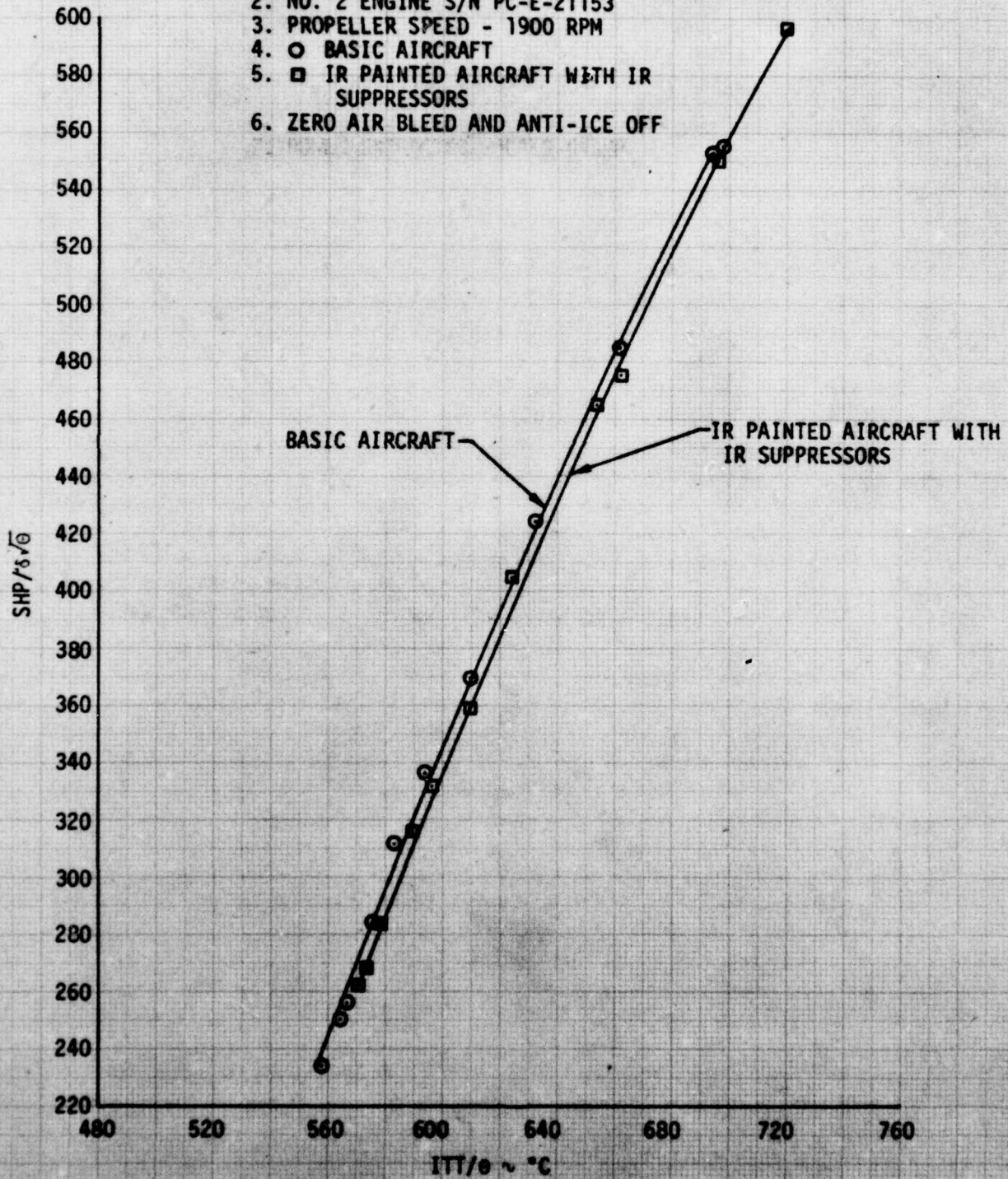

FIGURE 65
AIRSPEED CALIBRATION
U-21A USA S/N 66-18008
BASIC AIRCRAFT - SHIP SYSTEM POSITION ERROR

| SYM | AVG GROSS WEIGHT ~LB | AVG LONG CG LOCATION ~FS | AVG DENSITY ALTITUDE ~FT | AVG OAT ~°C | PROPELLER SPEED ~RPM | CONFIGURATION | FLIGHT CONDITION |
|-----|-------------------------|-----------------------------|-----------------------------|----------------|-------------------------|----------------|------------------|
| ○ | 9290 | 152.9(FWD) | 11760 | 10.5 | 1900 | CRUISE | LEVEL FLIGHT |
| □ | 9100 | 152.5(FWD) | 11930 | 11.0 | 2000 | POWER APPROACH | LEVEL FLIGHT |
| △ | 8970 | 152.3(FWD) | 11920 | 11.5 | 2200 | WAVEOFF | LEVEL FLIGHT |

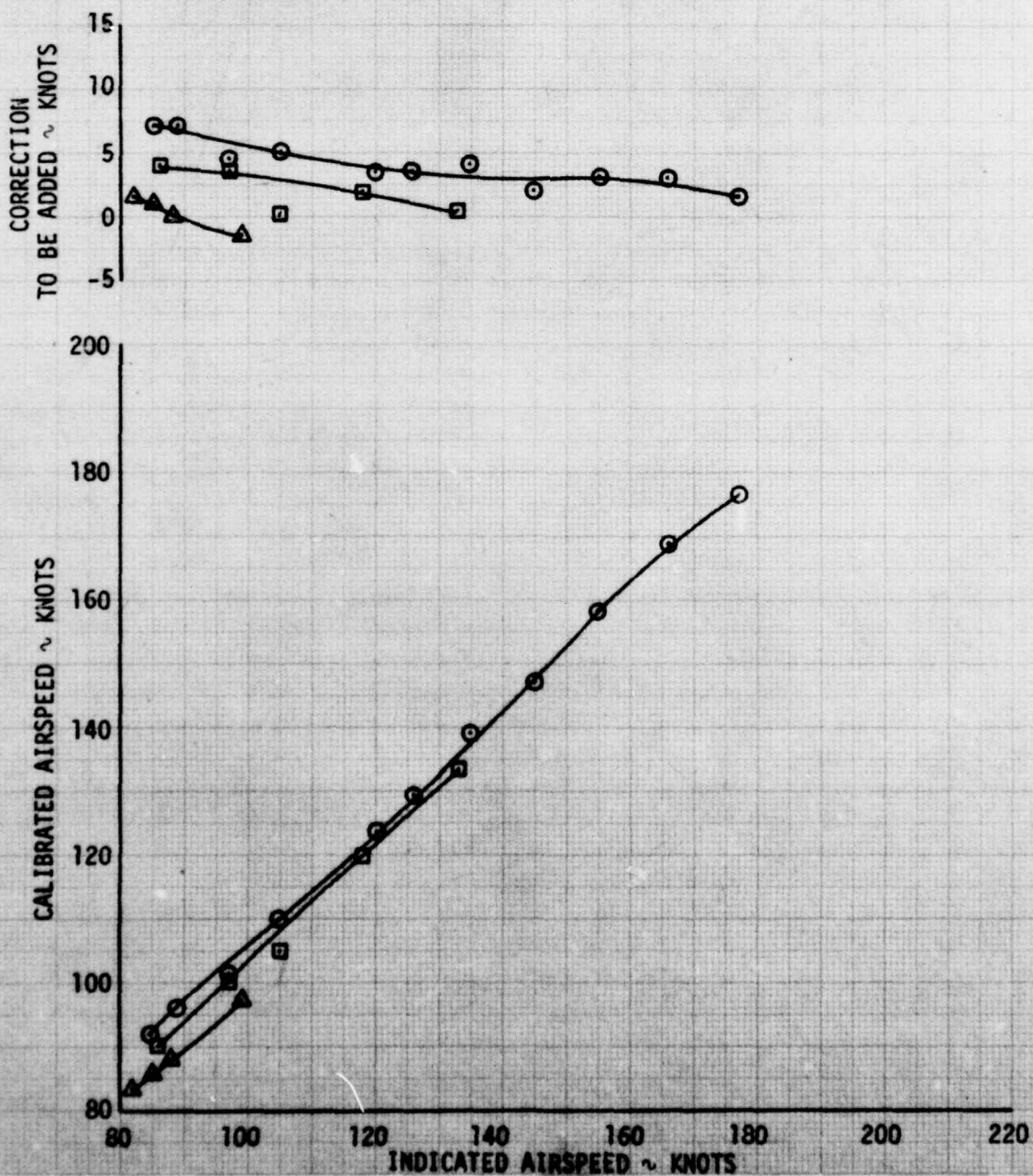

FIGURE 66
AIRSPEED CALIBRATION
U-21A USA S/N 66-18008
IR PAINTED AIRCRAFT - SHIP SYSTEM POSITION ERROR

| SYM | AVG GROSS WEIGHT ~LB | AVG LONG CG LOCATION ~FS | AVG DENSITY ALTITUDE ~FT | AVG OAT ~°C | PROPELLER SPEED ~RPM | CONFIGURATION | FLIGHT CONDITION |
|-----|-------------------------|-----------------------------|-----------------------------|----------------|-------------------------|----------------|------------------|
| ○ | 9200 | 152.7(FWD) | 11700 | 12.5 | 1900 | CRUISE | LEVEL FLIGHT |
| □ | 9100 | 152.5(FWD) | 11950 | 12.0 | 2000 | POWER APPROACH | LEVEL FLIGHT |

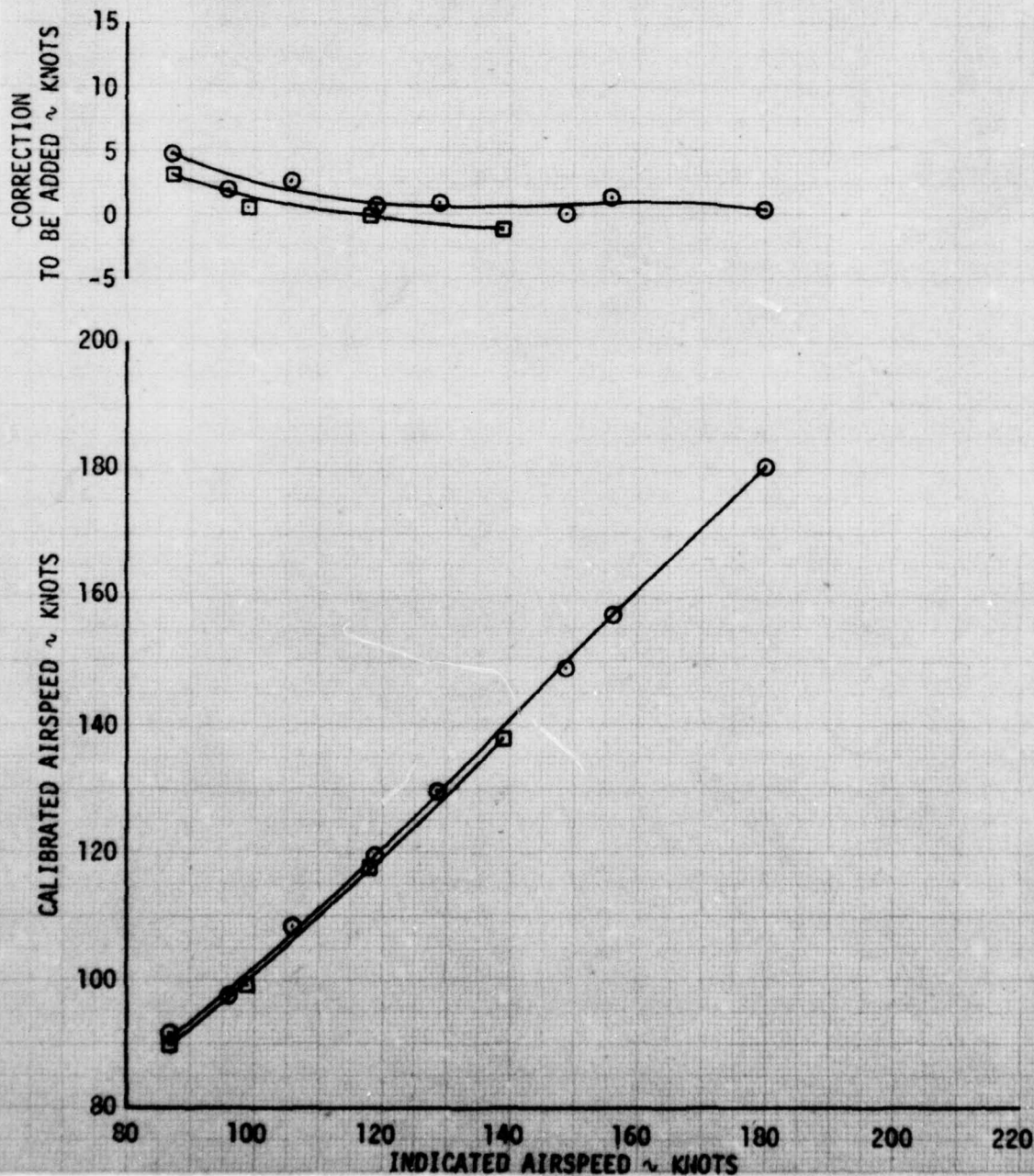
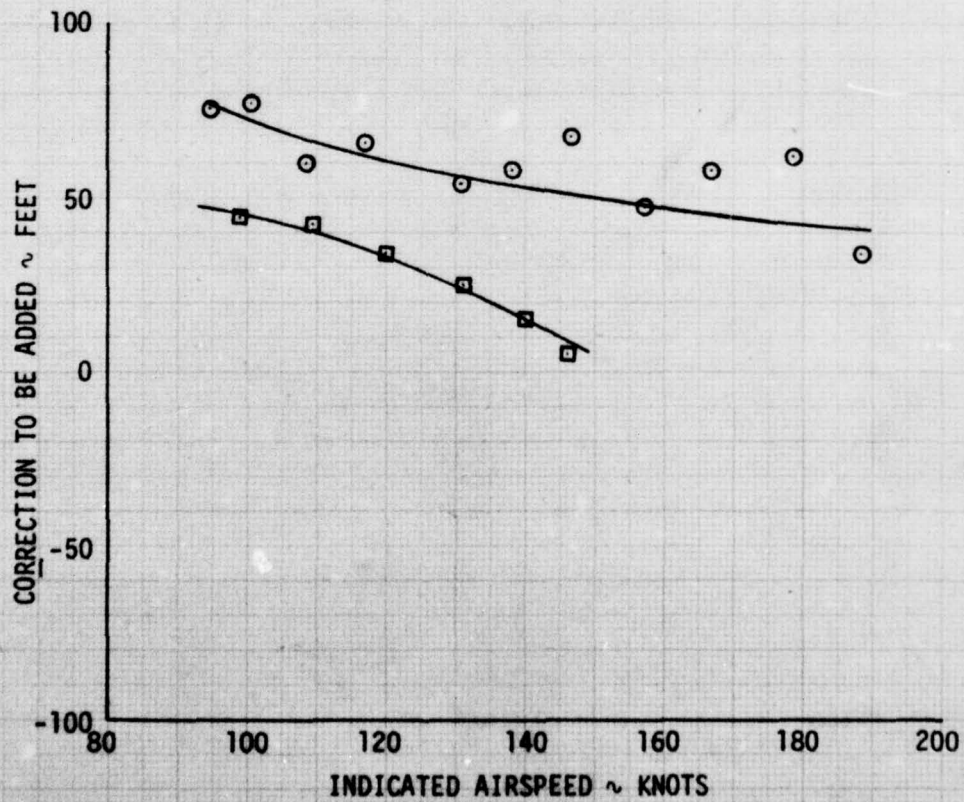

FIGURE 67
 ALTIMETER POSITION ERROR
 U-21A USA S/N 66-18008
 IR PAINTED AIRCRAFT - SHIP SYSTEM

| SYM | AVG GROSS WEIGHT ~LB | AVG LONG CG LOCATION ~FS | AVG DENSITY ALTITUDE ~FT | AVG OAT ~°C | PROPELLER SPEED ~RPM | CONFIGURATION | FLIGHT CONDITION |
|-----|-------------------------|-----------------------------|-----------------------------|----------------|-------------------------|----------------|------------------|
| ○ | 9100 | 152.5(FWD) | 11930 | 11.0 | 1900 | CRUISE | LEVEL FLIGHT |
| □ | 8390 | 159.5(FWD) | 12000 | 12.0 | 2000 | POWER APPROACH | LEVEL FLIGHT |



**FIGURE 68
 ALTIMETER POSITION ERROR
 U-21A USA S/N 66-18008
 BASIC AIRCRAFT - SHIP SYSTEM**

| SYM | AVG GROSS WEIGHT ~LB | AVG LONG CG LOCATION ~FS | AVG DENSITY ALTITUDE ~FT | AVG QAT ~°C | PROPELLER SPEED ~RPM | CONFIGURATION | FLIGHT CONDITION |
|-----|----------------------|--------------------------|--------------------------|-------------|----------------------|----------------|------------------|
| ○ | 9290 | 152.9(FWD) | 11760 | 10.5 | 1900 | CRUISE | LEVEL FLIGHT |
| □ | 9100 | 152.5(FWD) | 11930 | 11.0 | 2000 | POWER APPROACH | LEVEL FLIGHT |

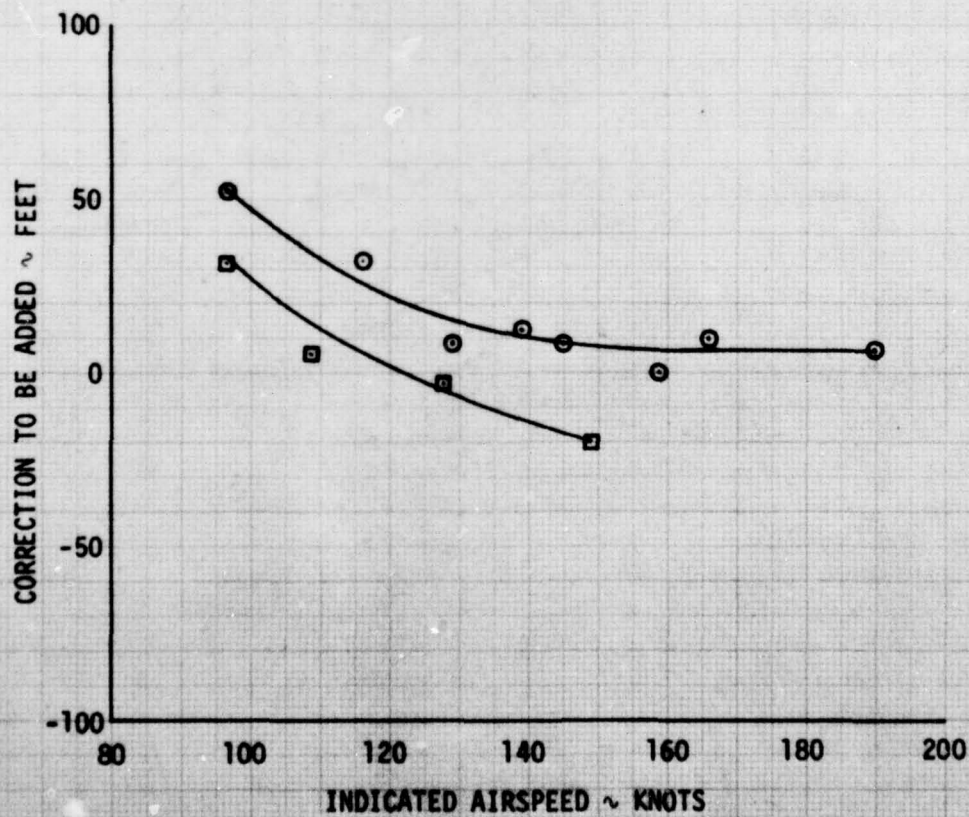

FIGURE 69
ALTIMETER POSITION ERROR
U-21A USA S/N 66-18008
BASIC AIRCRAFT - SHIP SYSTEM

- NOTES: 1. STANDARD DAY CONDITIONS - SEA LEVEL
2. GROSS WEIGHT = 9000 LB
3. PROPELLER SPEED
CRUISE = 1900 RPM
PA = 2000 RPM
4. LEVEL FLIGHT

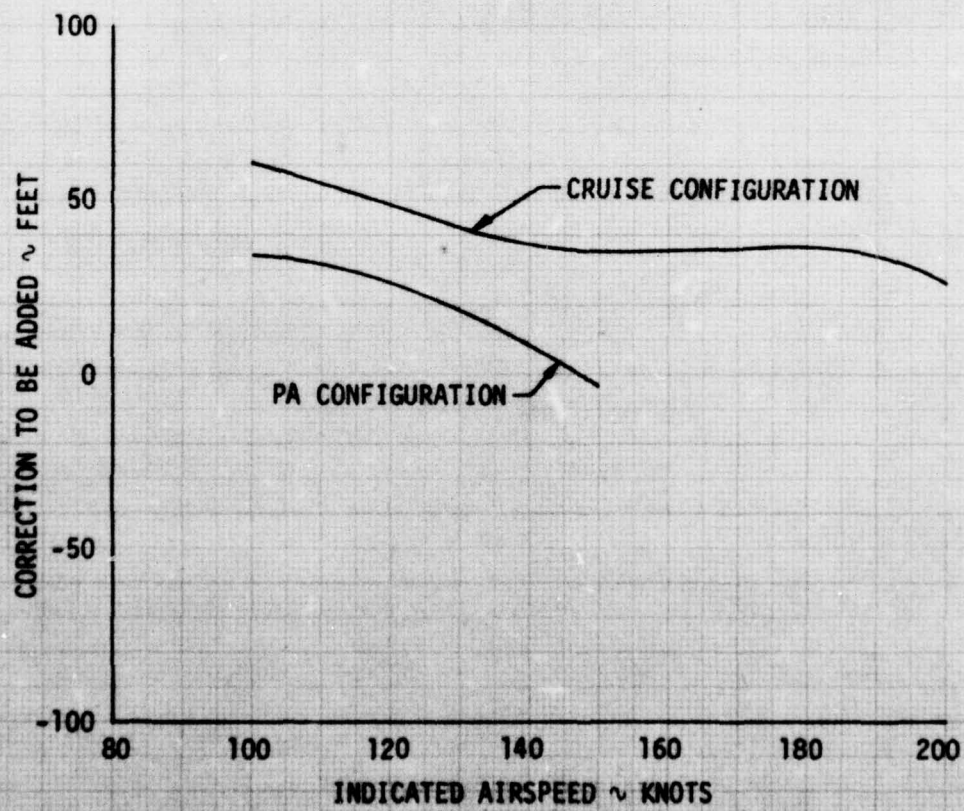

FIGURE 70
ALTIMETER POSITION ERROR
U-21A USA S/N 66-18008
IR PAINTED AIRCRAFT - SHIP SYSTEM

- NOTES:**
1. STANDARD DAY CONDITIONS - SEA LEVEL
 2. GROSS WEIGHT = 9000 LB
 3. PROPELLER SPEED
CRUISE = 1900 RPM
PA = 2000 RPM
 4. LEVEL FLIGHT

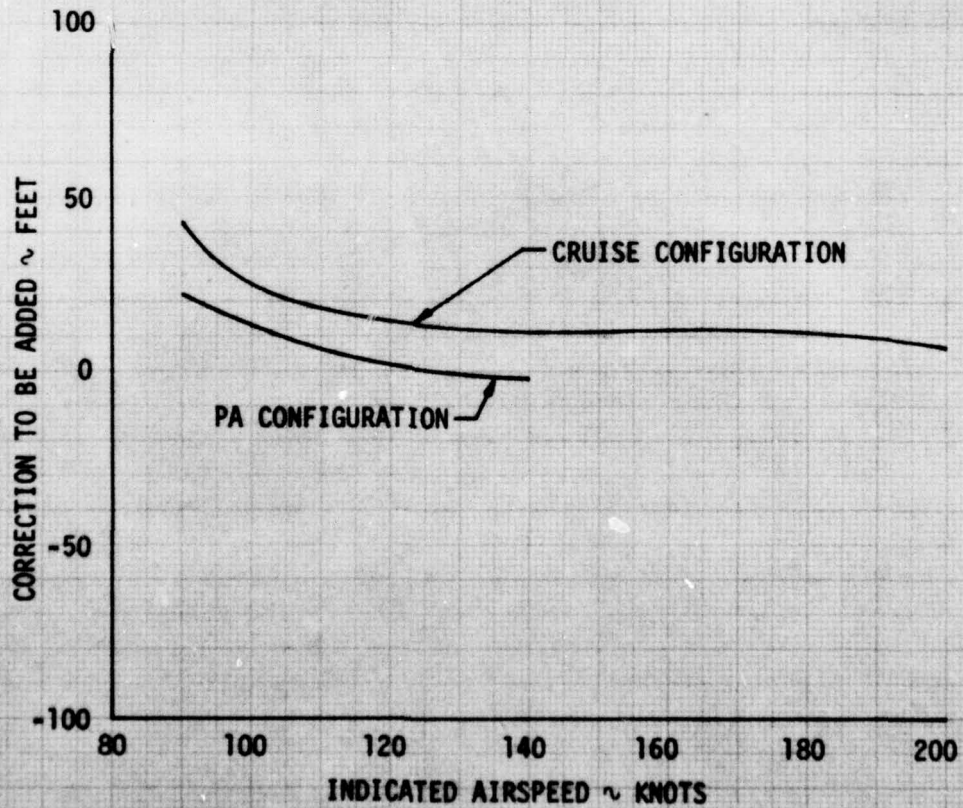

FIGURE 71
 PROPELLER FEATHERED GLIDE DRAG POLAR
 U-21A USA S/N 66-18008
 BASIC AIRCRAFT

| SYM | AVG GROSS WEIGHT ~ LB | AVG C.G. LOCATION ~ IN | AVG DENSITY ALTITUDE ~ FT | AVG OAT ~ °C | PROPELLER SPEED ~ RPM | CONFIGURATION | FLIGHT CONDITION |
|-----|--------------------------|---------------------------|------------------------------|-----------------|--------------------------|---------------|------------------|
| ○ | 9180 | 152.7 (FWD) | 11820 | 12.0 | 0 | CRUISE | GLIDE |
| □ | 8900 | 152.4 (FWD) | 11400 | 12.5 | 0 | TAKEOFF | GLIDE |

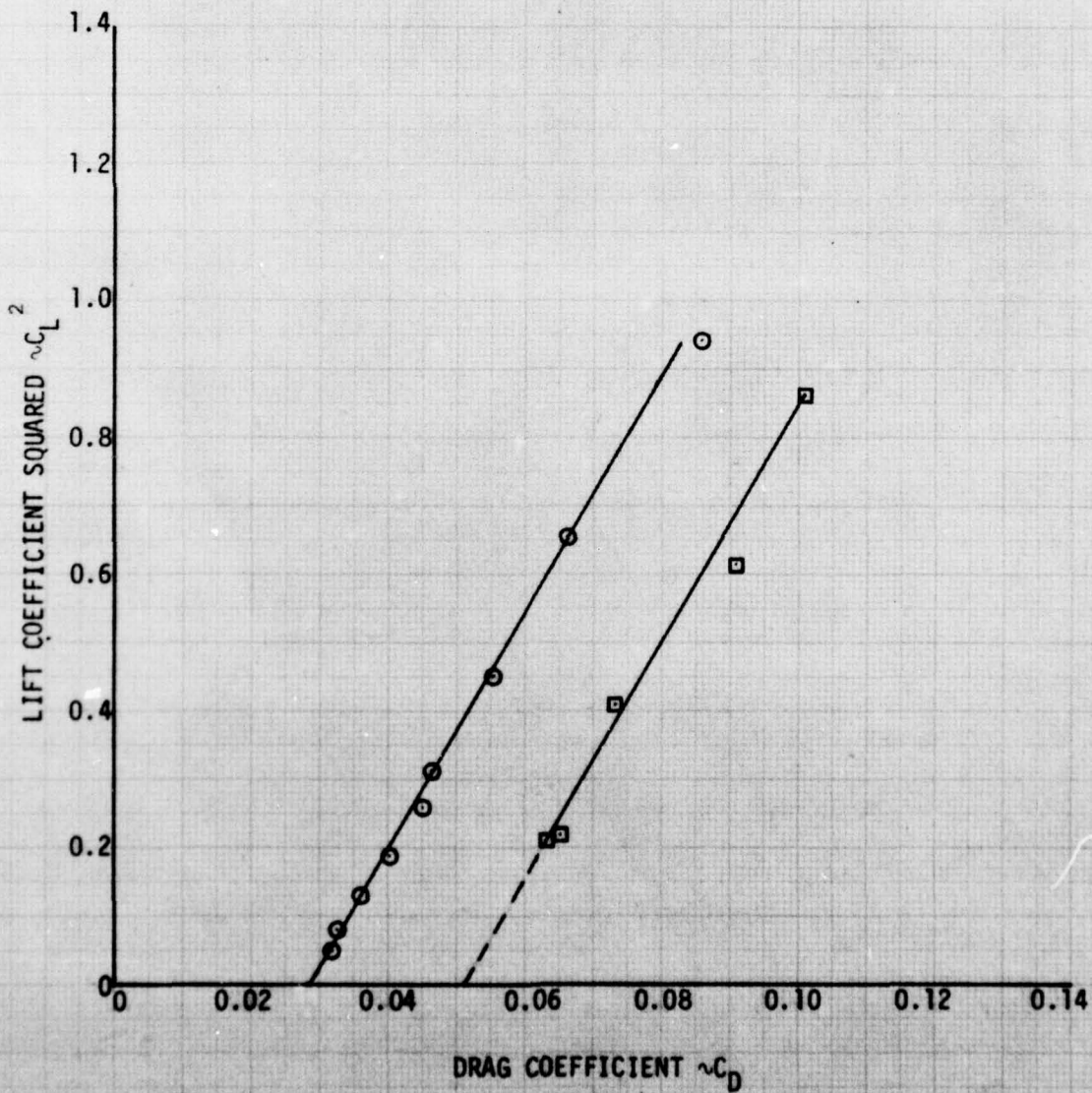

FIGURE 72
PROPELLER FEATHERED GLIDE DRAG POLAR
U-21A USA S/N 66-18008
IR PAINTED AIRCRAFT WITH STANDARD EXHAUST STUBS

| SYM | AVG GROSS WEIGHT ~ LB | AVG C.G. LOCATION ~ IN | AVG DENSITY ALTITUDE ~ FT | AVG OAT ~ °C | PROPELLER SPEED ~ RPM | CONFIGURATION | FLIGHT CONDITION |
|-----|--------------------------|---------------------------|------------------------------|-----------------|--------------------------|---------------|------------------|
| ○ | 9370 | 153.0 (FWD) | 11590 | 10.0 | 0 | CRUISE | GLIDE |
| □ | 8940 | 152.2 (FWD) | 11510 | 10.0 | 0 | TAKEOFF | GLIDE |

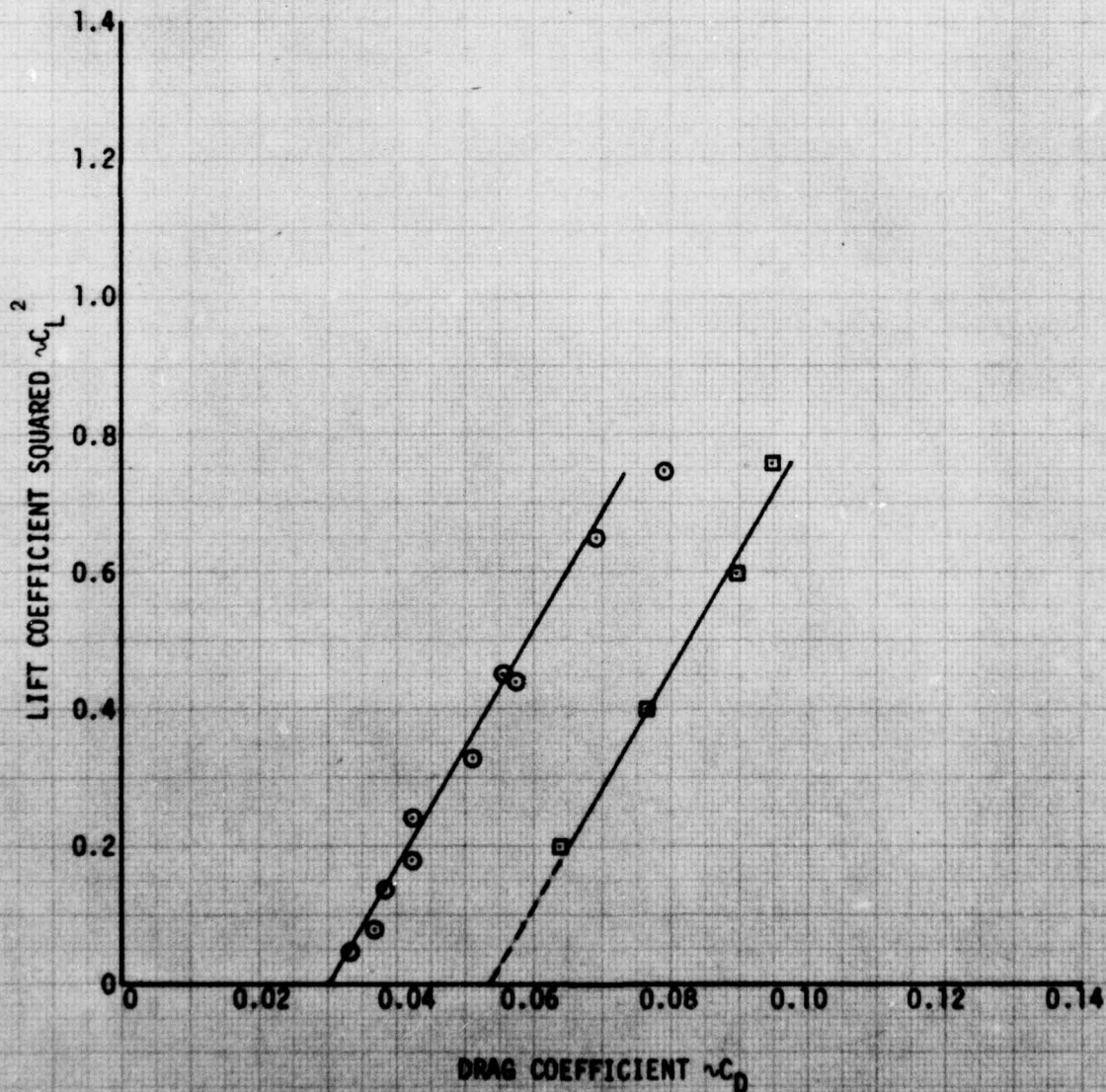

FIGURE 73
 PROPELLER FEATHERED GLIDE DRAG POLAR
 U-21A USA S/N 66-18008
 IR PAINTED AIRCRAFT WITH IR SUPPRESSORS

| SYM | AVG GROSS WEIGHT ~ LB | AVG C.G. LOCATION ~ IN | AVG DENSITY ALTITUDE ~ FT | AVG OAT ~ °C | PROPELLER SPEED ~ RPM | CONFIGURATION | FLIGHT CONDITION |
|-----|--------------------------|---------------------------|------------------------------|-----------------|--------------------------|---------------|------------------|
| ○ | 9230 | 152.7 (FWD) | 11170 | 7.5 | 0 | CRUISE | GLIDE |
| □ | 8980 | 152.2 (FWD) | 11050 | 8.0 | 0 | TAKEOFF | GLIDE |

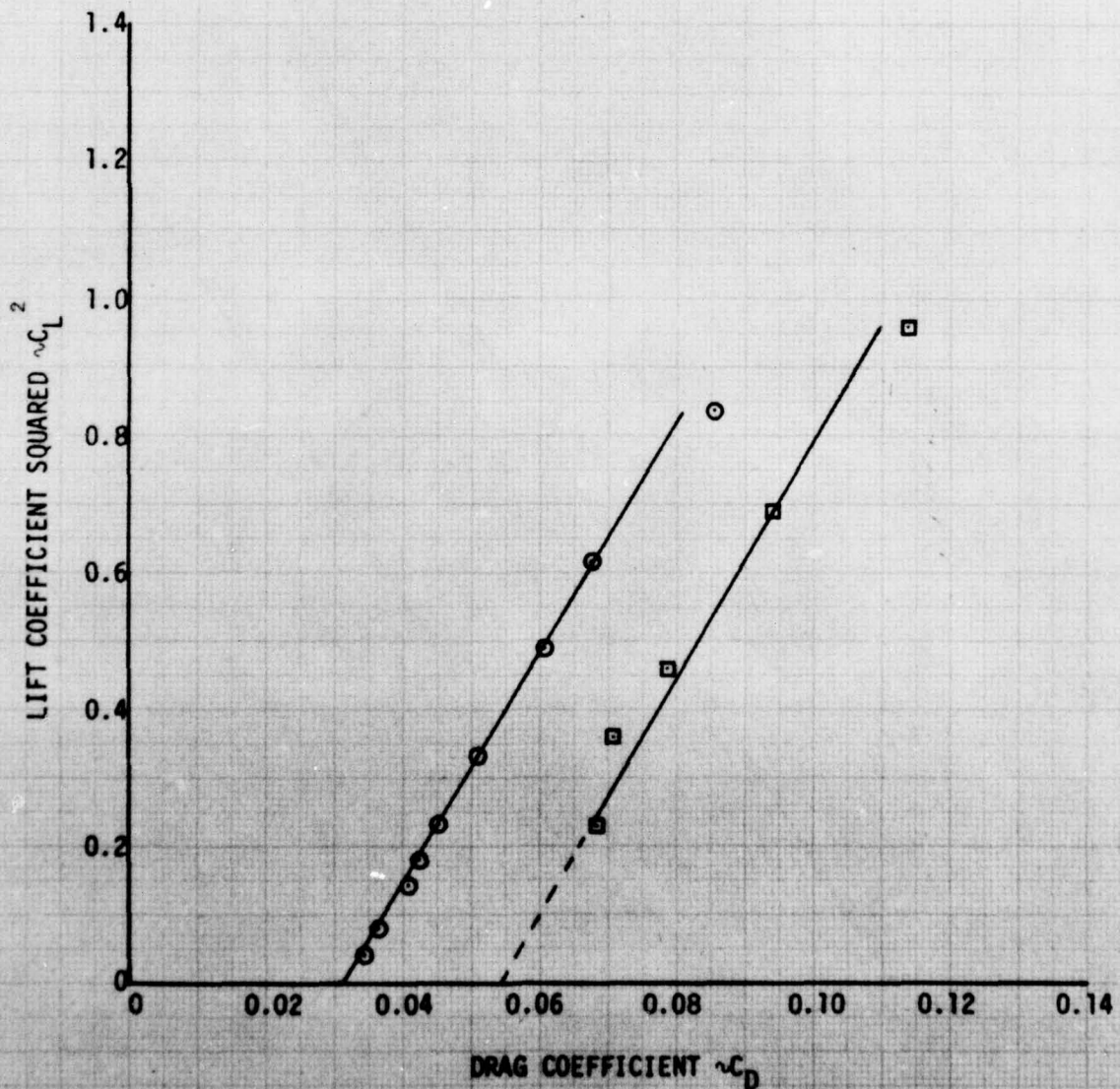

FIGURE 74
DUAL ENGINE LEVEL FLIGHT DRAG POLAR
U-21A USA S/N 66-18008
BASIC AIRCRAFT

| SYM | AVG GROSS WEIGHT ~ LB | AVG C.G. LOCATION ~ IN | AVG DENSITY ALTITUDE ~ FT | AVG OAT ~ °C | PROPELLER SPEED ~ RPM | CONFIGURATION | FLIGHT CONDITION |
|-----|--------------------------|---------------------------|------------------------------|-----------------|--------------------------|----------------|------------------|
| ○ | 9290 | 152.9 (FWD) | 11930 | 12.0 | 1900 | CRUISE | L.F. |
| □ | 9090 | 152.5 (FWD) | 12030 | 12.0 | 2000 | POWER APPROACH | L.F. |

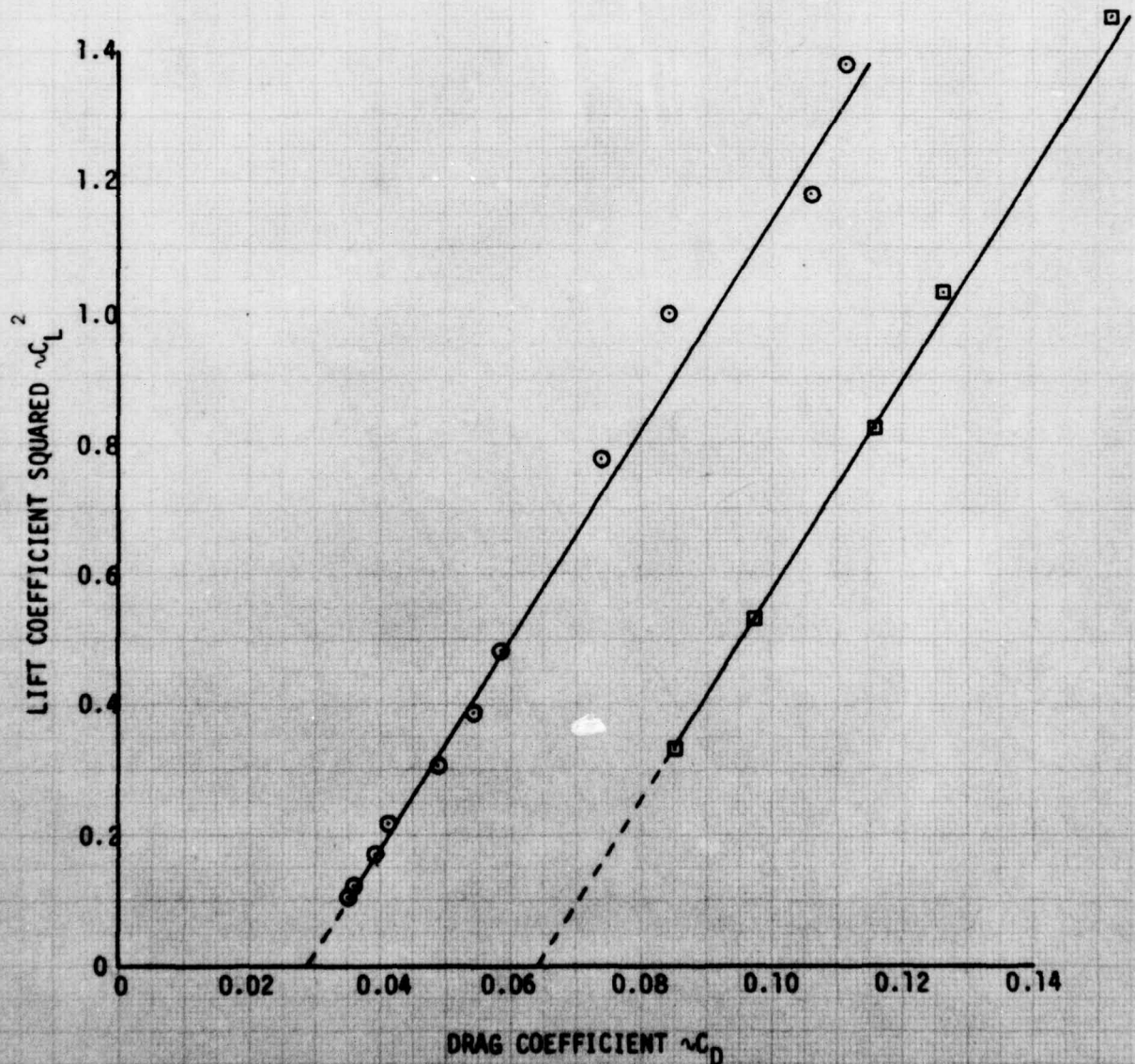

FIGURE 75
 DUAL ENGINE LEVEL FLIGHT DRAG POLAR
 U-21A USA S/N 66-18008
 IR PAINTED AIRCRAFT WITH IR SUPPRESSORS

| AVG GROSS WEIGHT ~ LB | AVG C.G. LOCATION ~ IN | AVG DENSITY ALTITUDE ~ FT | AVG OAT ~ °C | PROPELLER SPEED ~ RPM | CONFIGURATION | FLIGHT CONDITION |
|--------------------------|---------------------------|------------------------------|-----------------|--------------------------|---------------|------------------|
| 9280 | 1528 (FWD) | 10950 | 4.0 | 1900 | CRUISE | LEVEL FLIGHT |

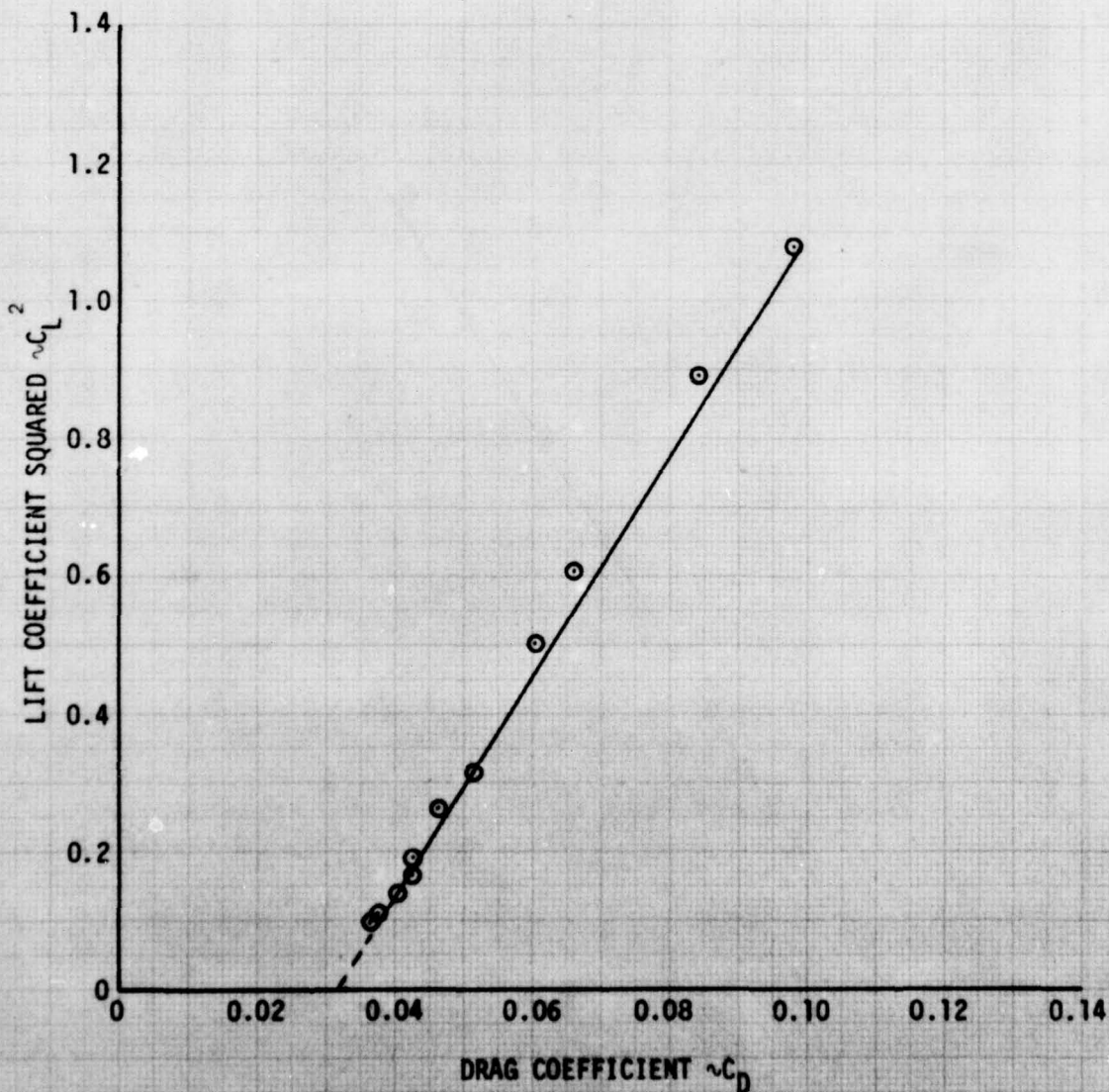

FIGURE 76
 SINGLE ENGINE LEVEL FLIGHT DRAG POLAR
 U-21A USA SIN 66-18008
 BASIC AIRCRAFT

| AVG GROSS WEIGHT ~ LB | AVG C.G. LOCATION ~ IN | AVG DENSITY ALTITUDE ~ FT | AVG OAT ~ °C | PROPELLER SPEED ~ RPM | CONFIGURATION | FLIGHT CONDITION |
|--------------------------|---------------------------|------------------------------|-----------------|--------------------------|---------------|------------------|
| 9210 | 152.7 (FWD) | 9110 | 19.0 | 1900 | LT ENG FEATH | L.F. |

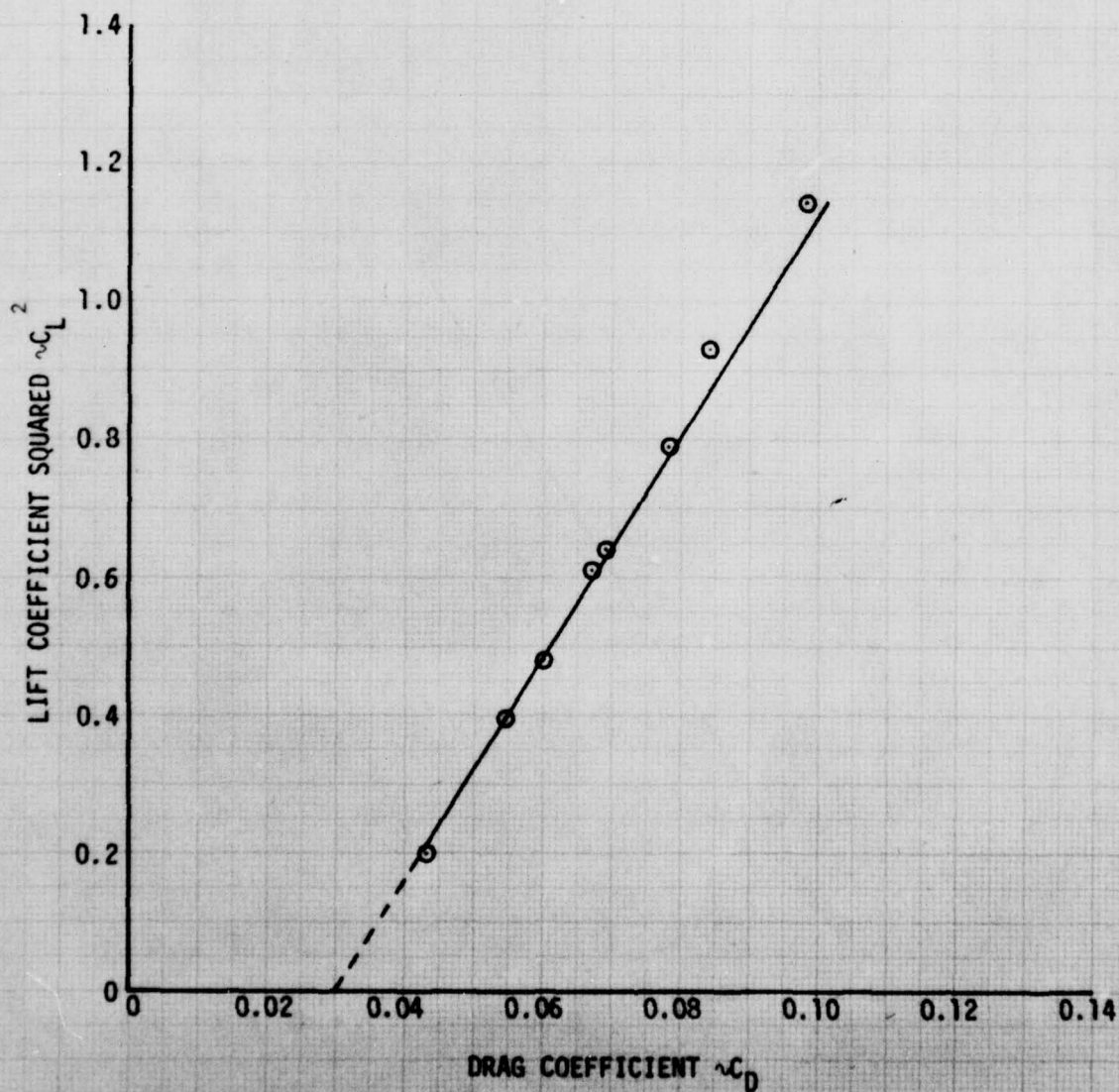

FIGURE 77
 SINGLE ENGINE LEVEL FLIGHT DRAG POLAR
 U-21A USA SIN 66-18008
 IR PAINTED AIRCRAFT WITH IR SUPPRESSORS

| AVG GROSS WEIGHT ~ LB | AVG C.G. LOCATION ~ IN | AVG DENSITY ALTITUDE ~ FT | AVG OAT ~ °C | PROPELLER SPEED ~ RPM | CONFIGURATION | FLIGHT CONDITION |
|--------------------------|---------------------------|------------------------------|-----------------|--------------------------|---------------|------------------|
| 9380 | 153.0 (FWD) | 8360 | 14.0 | 1900 | CRUISE | L.F. |

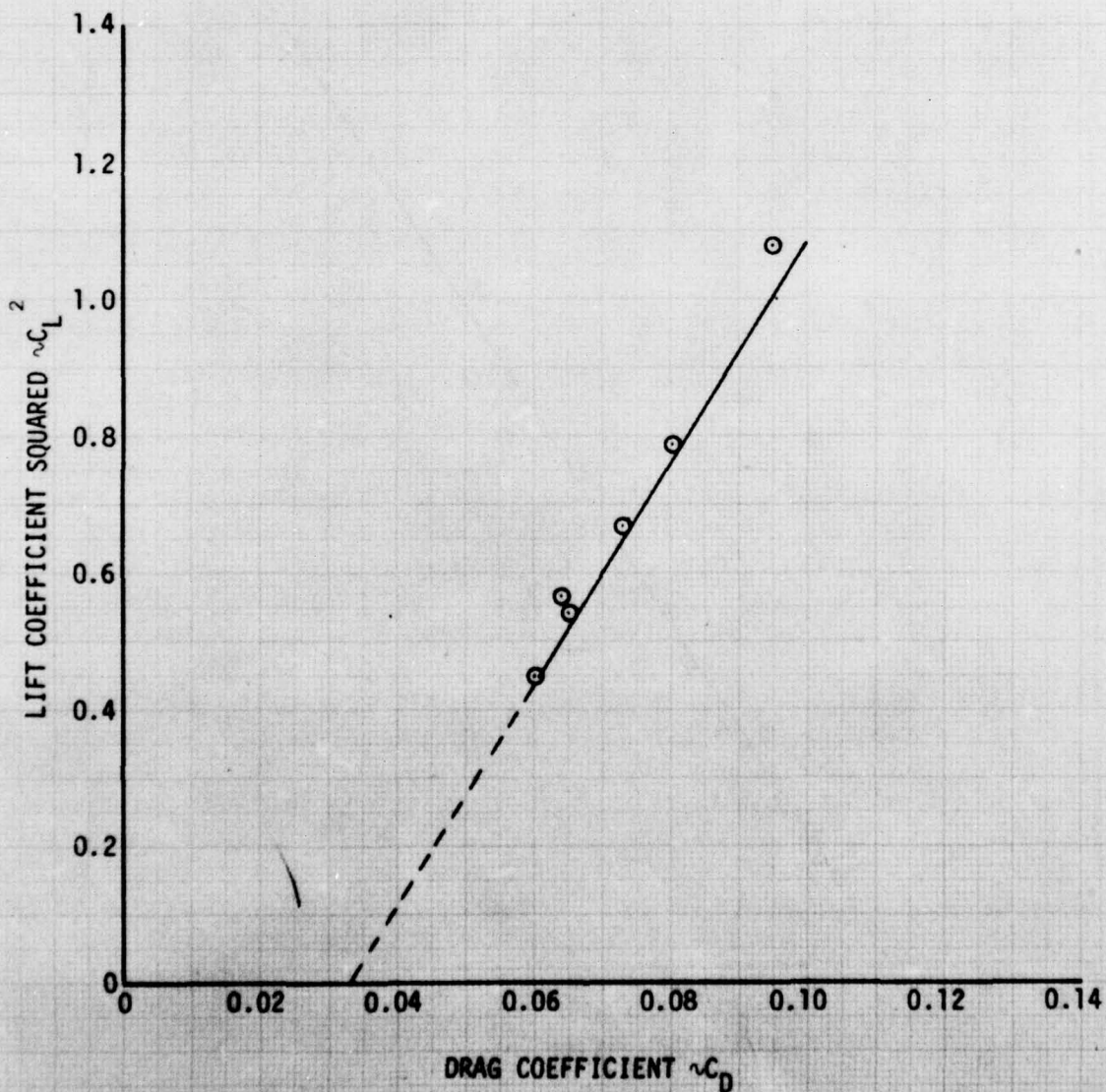

FIGURE 78
 DUAL ENGINE CLIMB DRAG POLAR
 U-21A USA SIN 66-18008
 BASIC AIRCRAFT

| SYM | AVG GROSS WEIGHT ~ LB | AVG C.G. LOCATION ~ IN | AVG DENSITY ALTITUDE ~ FT | AVG OAT ~ °C | PROPELLER SPEED ~ RPM | CONFIGURATION | FLIGHT CONDITION |
|-----|--------------------------|---------------------------|------------------------------|-----------------|--------------------------|---------------|------------------|
| ○ | 9010 | 150.6 (FWD) | 12160 | 11.0 | 2000 | CRUISE | CLIMB |
| □ | 9290 | 152.9 (FWD) | 11850 | 15.5 | 2000 | CRUISE | CLIMB |
| △ | 9180 | 152.7 (FWD) | 11820 | 12.0 | 2200 | CRUISE | CLIMB |

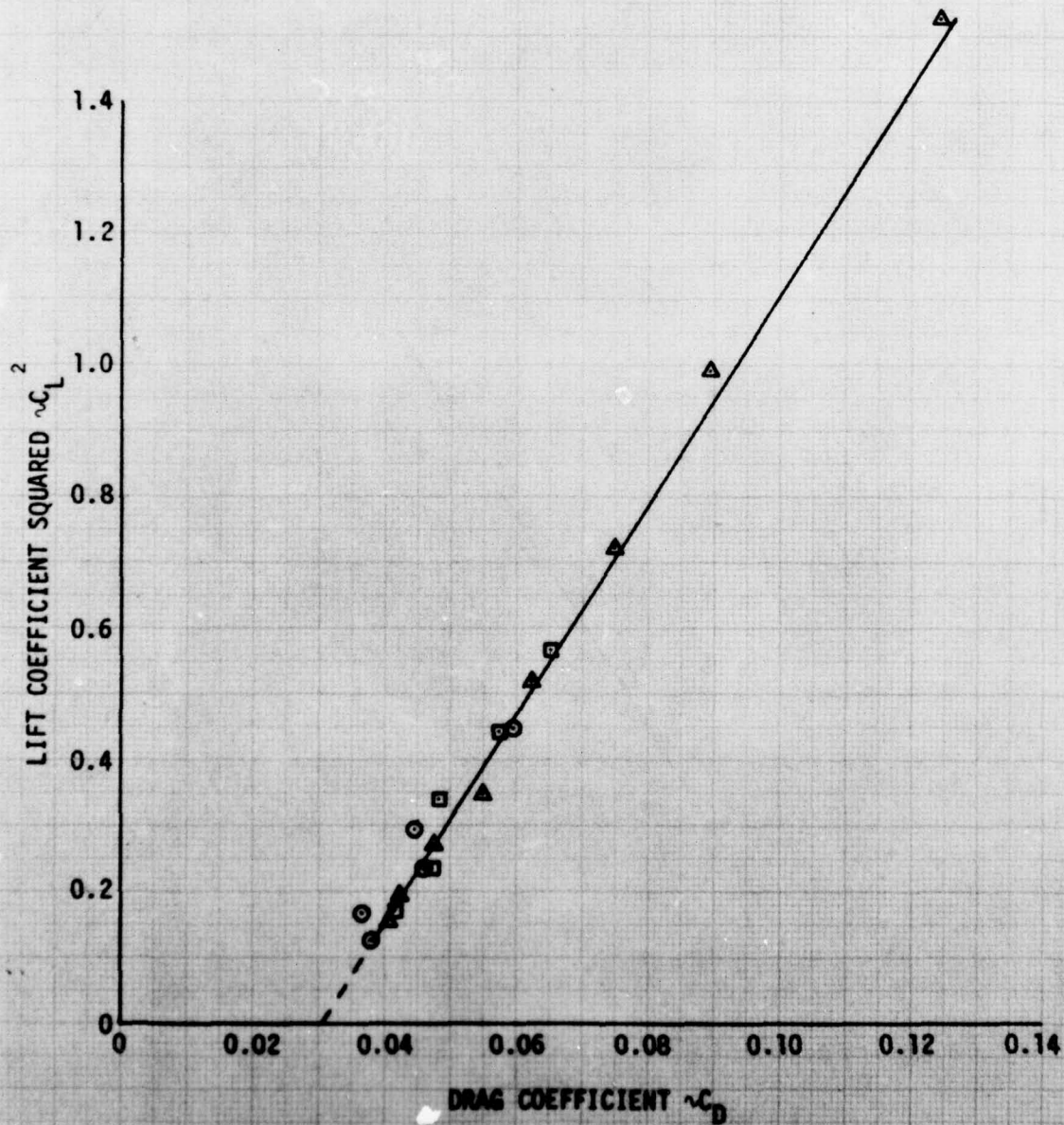

FIGURE 79
 DUAL ENGINE CLIMB DRAG POLAR
 U-21A USA SIN 66-18008
 IR PAINTED AIRCRAFT WITH STANDARD EXHAUST STUBS

| SYM | AVG GROSS WEIGHT ~ LB | AVG C.G. LOCATION ~ IN | AVG DENSITY ALTITUDE ~ FT | AVG OAT ~ °C | PROPELLER SPEED ~ RPM | CONFIGURATION | FLIGHT CONDITION |
|-----|--------------------------|---------------------------|------------------------------|-----------------|--------------------------|---------------|------------------|
| ○ | 9370 | 153.0 (FWD) | 11590 | 10.0 | 2000 | CRUISE | CLIMB |
| □ | 8940 | 152.2 (FWD) | 11510 | 10.0 | 2000 | TAKEOFF | CLIMB |

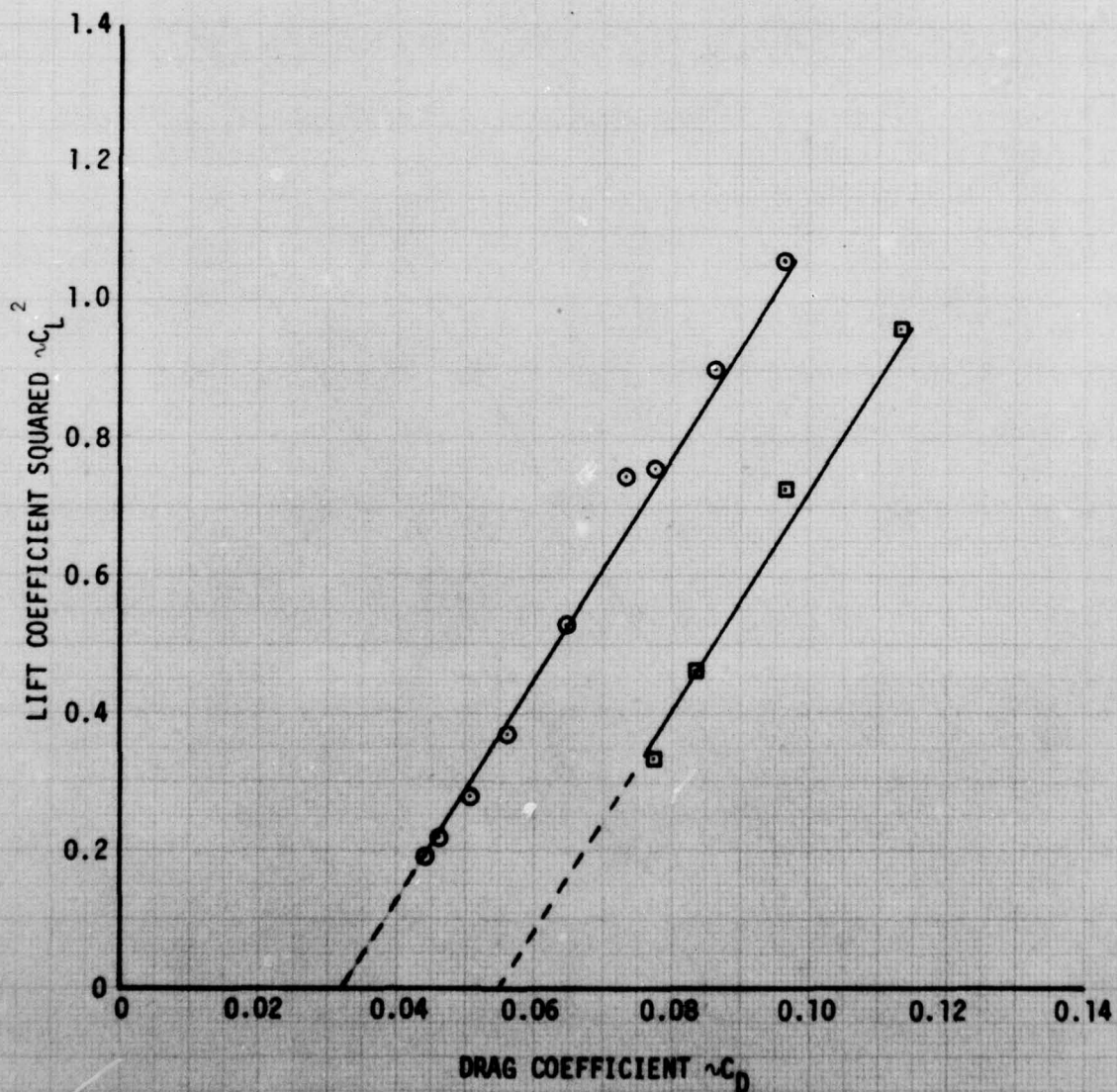

FIGURE 80
 DUAL ENGINE CLIMB DRAG POLAR
 U-21A USA SIN 66-18008
 IR PAINTED AIRCRAFT WITH IR SUPPRESSORS

| SYM | AVG GROSS WEIGHT ~ LB | AVG C.G. LOCATION ~ IN | AVG DENSITY ALTITUDE ~ FT | AVG OAT ~ °C | PROPELLER SPEED ~ RPM | CONFIGURATION | FLIGHT CONDITION |
|-----|--------------------------|---------------------------|------------------------------|-----------------|--------------------------|---------------|------------------|
| ○ | 9230 | 152.7 (FWD) | 11170 | 7.5 | 2000 | CRUISE | CLIMB |
| □ | 8980 | 152.2 (FWD) | 11050 | 7.5 | 2200 | TAKEOFF | CLIMB |

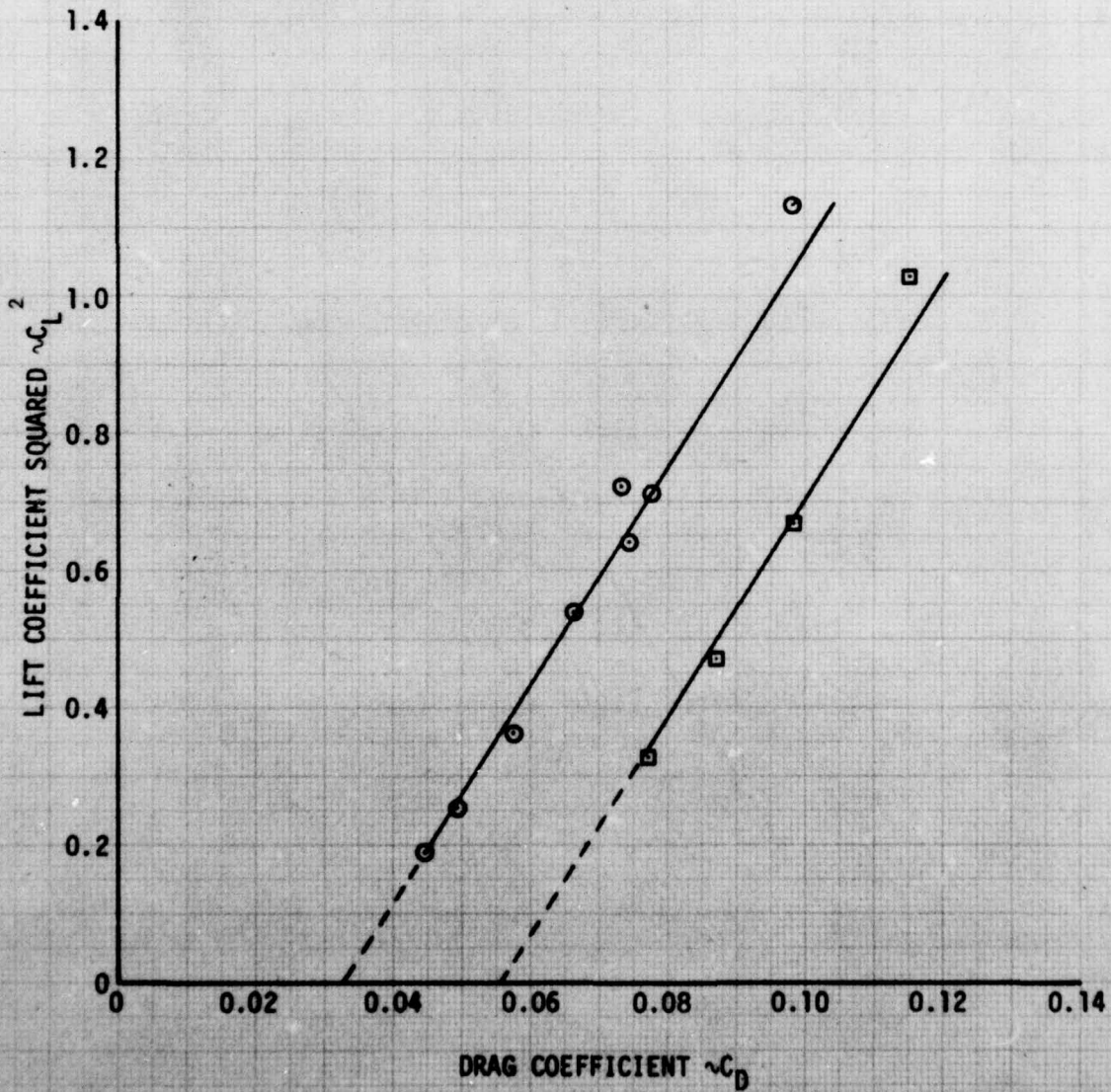

FIGURE 81
 SINGLE ENGINE CLIMB DRAG POLAR
 U-21A USA SIN 66-18008
 BASIC AIRCRAFT

| AVG GROSS WEIGHT ~ LB | AVG C.G. LOCATION ~ IN | AVG DENSITY ALTITUDE ~ FT | AVG OAT ~ °C | PROPELLER SPEED ~ RPM | CONFIGURATION LT ENG FEATH | FLIGHT CONDITION CLIMB |
|--------------------------|---------------------------|------------------------------|-----------------|--------------------------|-------------------------------|---------------------------|
| 9030 | 152.4 (FWD) | 8990 | 19.5 | 2200 | | |

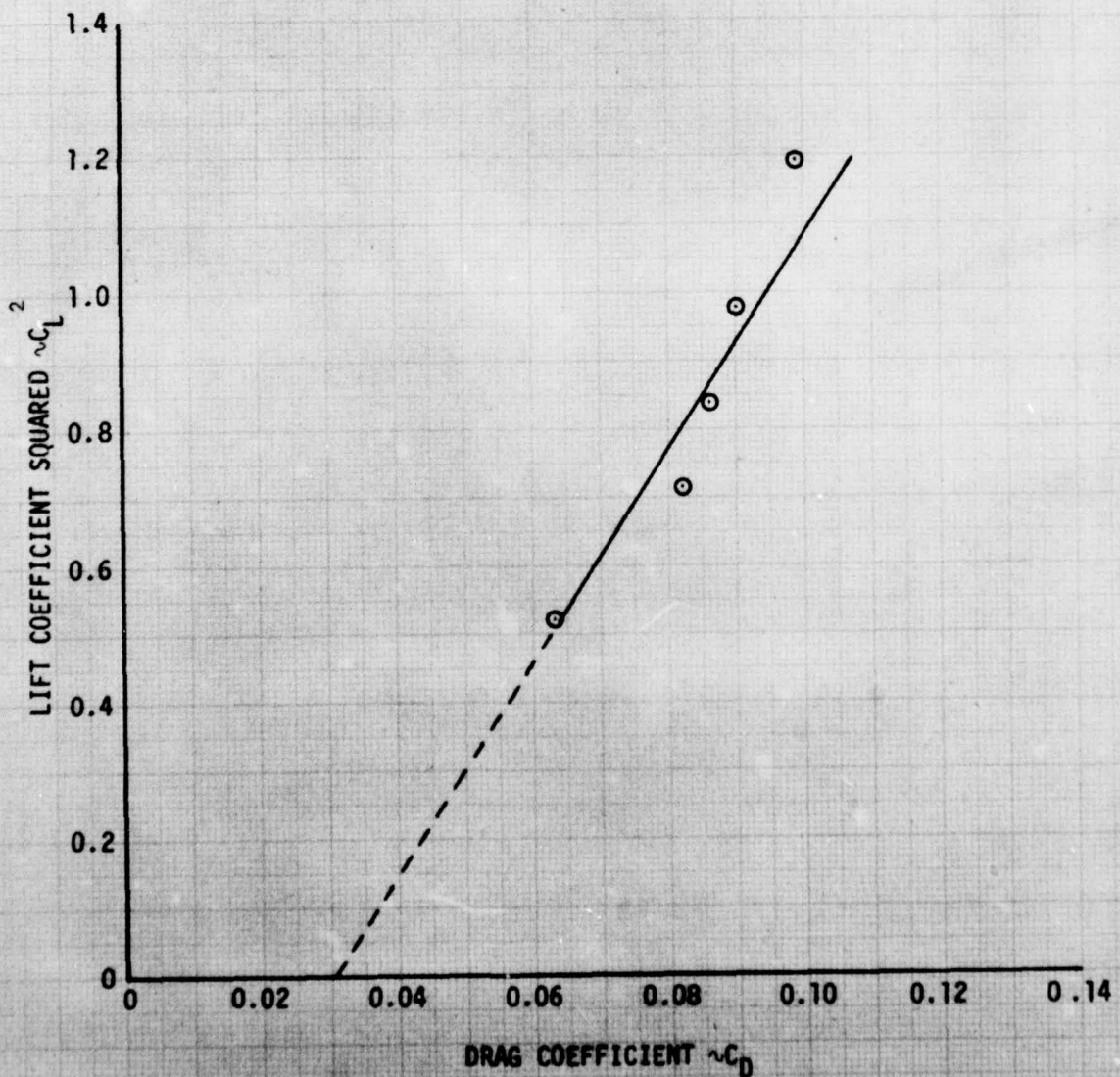
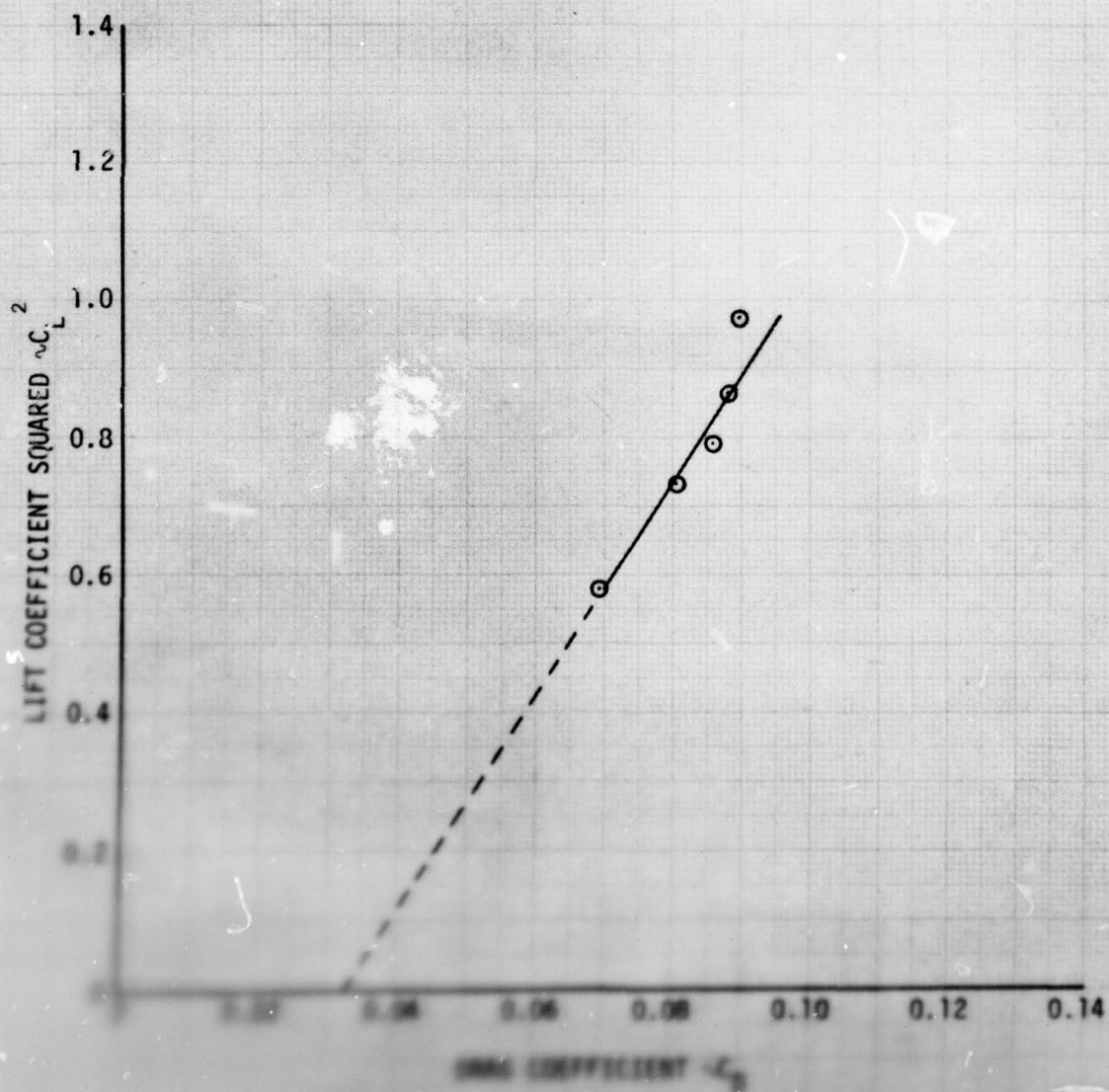

FIGURE 82
 SINGLE ENGINE CLIMB DRAG POLAR
 U-21A USA SIN 66-18008
 IR PAINTED AIRCRAFT WITH IR SUPPRESSORS

| AVG GROSS WEIGHT | AVG C.G. LOCATION | AVG DENSITY ALTITUDE | AVG OAT | PROPELLER SPEED | CONFIGURATION | FLIGHT CONDITION |
|------------------|---------------------|----------------------|--------------|-----------------|----------------------------|------------------|
| ~ LB 9180 | ~ IN 152.6 (FWD) | ~ FT 8400 | ~ °C 14.0 | ~ RPM 2200 | CRUISE LT ENG FEATHERED | CLIMB |



APPENDIX G. DRAG POLAR COEFFICIENT TABLES

Table 1. Climb Drag Polar Coefficients.¹

a. Basic Aircraft

| Configuration | Number of Engines Operating | C_{D_0} | $\frac{\Delta C_D}{\Delta C_L^2}$ | A | B |
|---------------|-----------------------------|-----------|-----------------------------------|---------|-----------|
| Cruise | Zero | 0.02857 | 0.05764 | Zero | Zero |
| | 1 | | | 0.06726 | -0.000009 |
| | 2 | | | 0.03078 | 0.000502 |

b. Painted Aircraft With Standard Stacks

| Configuration | Number of Engines Operating | C_{D_0} | $\frac{\Delta C_D}{\Delta C_L^2}$ | A | B |
|---------------|-----------------------------|-----------|-----------------------------------|---------|----------|
| Cruise | Zero | 0.03110 | 0.05764 | Zero | Zero |
| | 1 | | | 0.06726 | 0.000397 |
| | 2 | | | 0.03078 | 0.000312 |

c. Painted Aircraft With IR Stacks

| Configuration | Number of Engines Operating | C_{D_0} | $\frac{\Delta C_D}{\Delta C_L^2}$ | A | B |
|---------------|-----------------------------|-----------|-----------------------------------|---------|----------|
| Cruise | Zero | 0.03172 | 0.05764 | Zero | Zero |
| | 1 | | | 0.06726 | 0.000601 |
| | 2 | | | 0.03078 | 0.000261 |

¹General drag equation: $C_D = C_{D_0} + \frac{\Delta C_D}{\Delta C_L^2} C_L^2 + AT_C + B$

Table 2. Climb Drag Polar Coefficients.¹

a. Basic Aircraft

| Configuration | Number of Engines Operating | C_{D_0} | $\frac{\Delta C_D}{\Delta C_L^2}$ | A | B |
|---------------|-----------------------------|-----------|-----------------------------------|---------|----------|
| Takeoff | Zero | 0.05130 | 0.05764 | Zero | Zero |
| | 1 | | | NA | NA |
| | 2 | | | 0.03078 | 0.000349 |

b. Painted Aircraft With Standard Stacks

| Configuration | Number of Engines Operating | C_{D_0} | $\frac{\Delta C_D}{\Delta C_L^2}$ | A | B |
|---------------|-----------------------------|-----------|-----------------------------------|---------|----------|
| Takeoff | Zero | 0.05353 | 0.05764 | Zero | Zero |
| | 1 | | | NA | NA |
| | 2 | | | 0.03078 | 0.000090 |

c. Painted Aircraft With IR Stacks

| Configuration | Number of Engines Operating | C_{D_0} | $\frac{\Delta C_D}{\Delta C_L^2}$ | A | B |
|---------------|-----------------------------|-----------|-----------------------------------|---------|---------|
| Takeoff | Zero | 0.5445 | 0.05764 | Zero | Zero |
| | 1 | | | NA | NA |
| | 2 | | | 0.03078 | 0.00090 |

¹General drag equation: $C_D = C_{D_0} + \frac{\Delta C_D}{\Delta C_L^2} C_r^2 + AT_C' + B$

Table 3. Level Flight Drag Polar Coefficients.¹

a. Basic Aircraft

| Configuration | Number of Engines Operating | C_{D_o} | $\frac{\Delta C_D}{\Delta C_L^2}$ | A | B |
|---------------|-----------------------------|-----------|-----------------------------------|---------|----------|
| Cruise | Zero | 0.02857 | 0.05764 | Zero | Zero |
| | 1 | | | 0.07197 | -0.00153 |
| | 2 | | | 0.05909 | -0.00145 |

b. Painted Aircraft With Standard Stacks

| Configuration | Number of Engines Operating | C_{D_o} | $\frac{\Delta C_D}{\Delta C_L^2}$ | A | B |
|---------------|-----------------------------|-----------|-----------------------------------|---------|-----------|
| Cruise | Zero | 0.03110 | 0.05764 | Zero | Zero |
| | 1 | | | 0.07197 | -0.000939 |
| | 2 | | | 0.05909 | -0.000897 |

c. Painted Aircraft With IR Stacks

| Configuration | Number of Engines Operating | C_{D_o} | $\frac{\Delta C_D}{\Delta C_L^2}$ | A | B |
|---------------|-----------------------------|-----------|-----------------------------------|---------|-----------|
| Cruise | Zero | 0.03172 | 0.05764 | Zero | Zero |
| | 1 | | | 0.07197 | -0.000659 |
| | 2 | | | 0.05909 | -0.000630 |

¹General drag equation: $C_D = C_{D_o} + \frac{\Delta C_D}{\Delta C_L^2} C_L^2 + AT_C + B$

Table 4. Level Flight Drag Polar Coefficients.

a. Basic Aircraft

| Configuration | Number of Engines Operating | C_{D_0} | $\frac{\Delta C_D}{\Delta C_L^2}$ | A | B |
|---------------|-----------------------------|-----------|-----------------------------------|---------|----------|
| Takeoff | Zero | 0.05130 | 0.05764 | Zero | Zero |
| | 1 | | | NA | NA |
| | 2 | | | 0.05909 | -0.00278 |

b. Painted Aircraft With Standard Stacks

| Configuration | Number of Engines Operating | C_{D_0} | $\frac{\Delta C_D}{\Delta C_L^2}$ | A | B |
|---------------|-----------------------------|-----------|-----------------------------------|---------|----------|
| Takeoff | Zero | 0.05468 | 0.05764 | Zero | Zero |
| | 1 | | | NA | NA |
| | 2 | | | 0.05909 | -0.00223 |

c. Painted Aircraft With IR Stacks

| Configuration | Number of Engines Operating | C_{D_0} | $\frac{\Delta C_D}{\Delta C_L^2}$ | A | B |
|---------------|-----------------------------|-----------|-----------------------------------|---------|----------|
| Takeoff | Zero | 0.05445 | 0.05764 | Zero | Zero |
| | 1 | | | NA | NA |
| | 2 | | | 0.05909 | -0.00197 |

¹General drag equation: $C_D = C_{D_0} + \frac{\Delta C_D}{\Delta C_L^2} C_L^2 + AT_C + B$

APPENDIX H. LIST OF SYMBOLS AND ABBREVIATIONS

| | |
|----------------------------|---|
| B | Basic U-21A |
| BAC | Beech Aircraft Corporation |
| C_D | Coefficient of drag |
| C_{DBL} | Base-line coefficient of drag |
| $C_{D_{PF}}$ | Total coefficient of drag for powered flight |
| C_{D_0} | Propeller-feathered coefficient of drag |
| cg | Center of gravity |
| C_L | Coefficient of lift |
| CL | Climb configuration |
| CR | Cruise configuration |
| D | Drag force (lb) |
| d | Propeller diameter |
| dh/dt | Tapeline rate of descent (ft/min) |
| F_n | Jet thrust (lb) |
| FS | Fuselage station |
| fwd | Forward |
| g | Gravitational acceleration (ft/sec ²) |
| G | Glide configuration |
| H _p | Pressure altitude (ft) |
| H _{p_i} | Indicated pressure altitude (ft) |
| HQRS | Handling Qualities Rating Scale |
| Hz | Hertz (1 cycle per second) |
| IR | Infrared |
| J | Advance ratio |
| kt | Knot |
| KIAS | Knots indicated airspeed |
| KTAS | Knots true airspeed |
| L | Lift force (lb) |
| L | Landing configuration |
| LR | Low reflective |
| N _p | Propeller speed (rpm) |
| NRCP | Normal rated climb power |
| N ₁ | Gas producer speed |

| | |
|---------------------------------|--|
| OAT | Outside air temperature (°C) |
| P | Air pressure (in. of mercury) |
| P | LR-painted U-21A |
| PA | Power approach configuration |
| PLF | Power for level flight |
| P + S | LR-painted U-21A with IR suppressors installed |
| P w/o inst | LR-painted U-21A without pitot-static boom |
| PSSL | Standard day static sea-level pressure |
| q | Dynamic pressure = $1/2 \rho V_T^2$ |
| Q | Engine torque (ft-lb) |
| S | Wing area = 279.74 ft ² |
| S _a | Air distance (ft) |
| S _g | Ground distance (ft) |
| SHP | Shaft horsepower |
| T | Net thrust (lb) |
| T _a | Ambient temperature (°C) |
| T _C | Thrust coefficient |
| THP | Thrust horsepower |
| T _i | Indicated temperature (°C) |
| TO | Takeoff configuration |
| TSSL | Standard drag static sea-level temperature (°C) |
| UACL | United Aircraft of Canada, Ltd |
| USAAEFA | United States Army Aviation Engineering Flight Activity |
| V _{cal} | Calibrated airspeed (kt) |
| V _H | Maximum airspeed for level flight |
| V _{ic} | Indicated airspeed (corrected for instrument error) (kt) |
| V _{MC} | Single-engine minimum control airspeed (kt) |
| V _{MO} | Maximum operating airspeed (kt) |
| V _S | Stall airspeed (kt) |
| V _T | True airspeed (kt) |
| W | Aircraft gross weight (lb) |
| WO | Waveoff configuration |
| ΔC _{D_o} | Drag coefficient due to test instrumentation boom |
| ΔC _{D_{PF-BL}} | Increased coefficient of drag due to thrust effects |
| ΔH _{PC} | Static source position error (ft) |

| | |
|---------------------|---|
| $\Delta H_{p_{ic}}$ | Indicated pressure altitude instrument error |
| ΔT_C | Indicated temperature correction due to compressibility ($^{\circ}C$) |
| ΔT_{ic} | Indicated temperature instrument error ($^{\circ}C$) |
| θ | Temperature ratio |
| δ | Pressure ratio |
| Υ | Descent angle (deg) |
| ρ | Air density (slug/ft ³) |
| ζ | Damping ratio |
| η_p | Propeller efficiency |
| ω_n | Undamped natural frequency (Hz) |
| σ | Density ratio |
| Subscript s | Standard data |
| Subscript t | Test data |

DISTRIBUTION

| | |
|---|----|
| Director of Defense Research and Engineering | 2 |
| Deputy Director of Test and Evaluation, OSD (OAD(SSST&E)) | 1 |
| Assistant Secretary of the Army (R&D), Deputy for Aviation | 1 |
| Deputy Chief of Staff for Research, Development, and Acquisition (DAMA-WSA, DAMA-RA, DAMA-PPM-T) | 4 |
| US Army Materiel Development and Readiness Command (DRSAV-WF, DRCSF-A, DRCQA) | 4 |
| US Army Aviation Systems Command (DRSAV-EQ) | 12 |
| US Army Training and Doctrine Command (ATCD-CM-C) | 1 |
| US Army Materiel Systems Analysis Activity (DRXSY-CM) | 2 |
| US Army Test and Evaluation Command (DRSTE-AV, USMC LnO) | 3 |
| US Army Electronics Command (AMSEL-VL-D) | 1 |
| US Army Forces Command (AFOP-AV) | 1 |
| US Army Armament Command (SARRI-LW) | 2 |
| US Army Missile Command (DRSMI-QT) | 1 |
| Hq US Army Air Mobility R&D Laboratory (SAVDL-D) | 2 |
| US Army Air Mobility R&D Laboratory (SAVDL-SR) | 1 |
| Ames Directorate, US Army Air Mobility R&D Laboratory (SAVDL-AM) | 2 |
| Eustis Directorate, US Army Air Mobility R&D Laboratory (SAVDL-EU-SY) | 2 |
| Langley Directorate, US Army Air Mobility R&D Laboratory (SAVDL-LA) | 2 |
| Lewis Directorate, US Army Air Mobility R&D Laboratory (SAVDL-LE-DD) | 1 |
| US Army Aeromedical Research Laboratory | 1 |
| US Army Aviation Center (ATZQ-D-MT) | 3 |
| US Army Aviation School (ATZQ-AS, ATST-CTD-DPS) | 3 |
| US Army Aircraft Development Test Activity (PROV) (STEBG-CO-T, STEBG-PO, STEBG-MT) | 5 |
| US Army Agency for Aviation Safety (IGAR-TA, IGAR-Library) | 2 |
| US Army Maintenance Management Center (DRXMD-EA) | 1 |
| US Army Transportation School (ATSP-CD-MS) | 1 |
| US Army Logistics Management Center | 1 |
| US Army Foreign Science and Technology Center (AMXST-WS4) | 1 |
| US Military Academy | 3 |
| US Marine Corps Development and Education Command | 2 |

| | |
|---|----|
| US Naval Air Test Center | 1 |
| US Air Force Aeronautical Division (ASD-ENFTA) | 1 |
| US Air Force Flight Dynamics Laboratory (TST/Library) | 1 |
| US Air Force Flight Test Center (SSD/Technical Library, DOEE) | 3 |
| US Air Force Electronic Warfare Center (SURP) | 1 |
| Department of Transportation Library | 1 |
| US Army Hughes Plant Activity | 2 |
| Beech Aircraft Corporation | 5 |
| Hughes Helicopter Company | 5 |
| United Aircraft of Canada Ltd | 5 |
| Defense Documentation Center | 12 |