

AD-A047 795

ARMY ENGINEER WATERWAYS EXPERIMENT STATION VICKSBURG MISS F/G 17/2
INVESTIGATION OF REMOTE WATER-QUALITY MONITORING SYSTEMS FOR US--ETC(U)
NOV 77 A W FORD

UNCLASSIFIED

WES-TR-Y-77-5

NL

| of |

AD
A047795

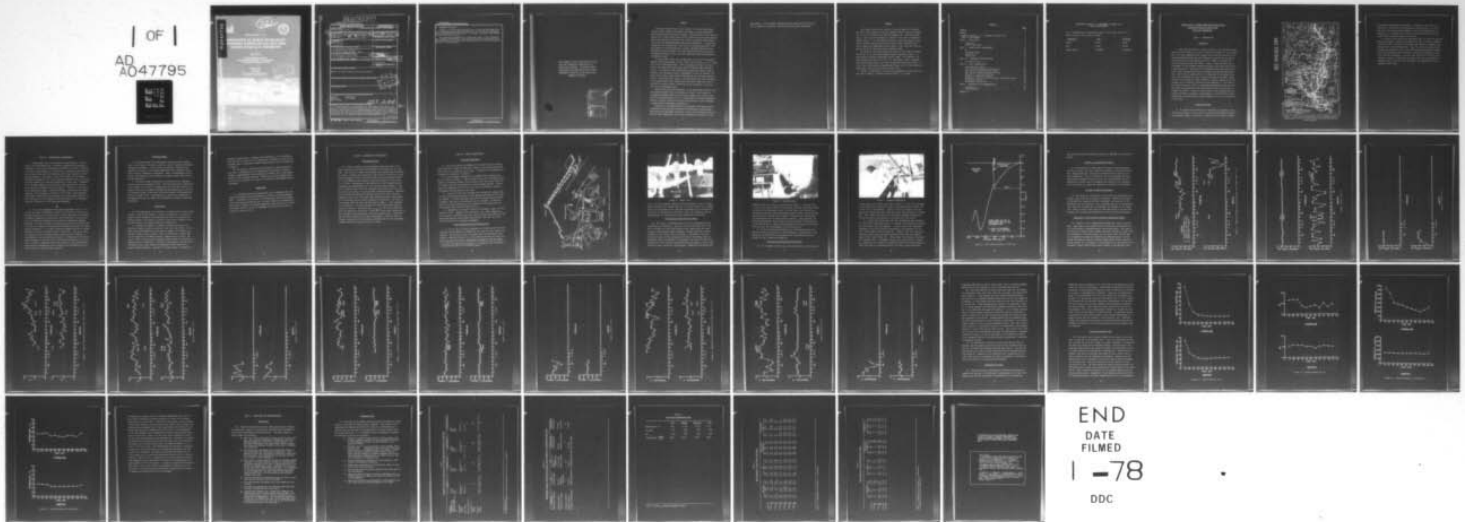

END
DATE
FILMED
1 -78
DDC

TECHNICAL REPORT Y-77-5

**INVESTIGATION OF REMOTE WATER-QUALITY
MONITORING SYSTEMS FOR USE WITH GOES
OR ERTS WATER DATA TRANSMITTER**

by

Alfred W. Ford

**Environmental Effects Laboratory
U. S. Army Engineer Waterways Experiment Station
P. O. Box 631, Vicksburg, Miss. 39180**

D D
FORM

14 WES-TR-Y-77-5

Unclassified

SECURITY CLASSIFICATION OF THIS PAGE (When Data Entered)

REPORT DOCUMENTATION PAGE		READ INSTRUCTIONS BEFORE COMPLETING FORM
1. REPORT NUMBER Technical Report Y-77-5 ✓	2. GOVT ACCESSION NO.	3. RECIPIENT'S CATALOG NUMBER
4. TITLE (and Subtitle) INVESTIGATION OF REMOTE WATER-QUALITY MONITORING SYSTEMS FOR USE WITH GOES OR ERIS WATER DATA TRANSMITTER	5. TYPE OF REPORT & PERIOD COVERED Final Report, Jul-Dec '76	6. PERFORMING ORG. REPORT NUMBER
7. AUTHOR(s) Alfred W./Ford	8. CONTRACT OR GRANT NUMBER(s)	
9. PERFORMING ORGANIZATION NAME AND ADDRESS U. S. Army Engineer Waterways Experiment Station Environmental Effects Laboratory P. O. Box 631, Vicksburg, Miss. 39180	10. PROGRAM ELEMENT, PROJECT, TASK AREA & WORK UNIT NUMBERS	
11. CONTROLLING OFFICE NAME AND ADDRESS River and Reservoir Control Center U. S. Army Engineer Division, Lower Mississippi Valley, Vicksburg, Miss. 39180	12. REPORT DATE Nov 1977	
14. MONITORING AGENCY NAME & ADDRESS (if different from Controlling Office)	13. NUMBER OF PAGES 46	12/50p.
	15. SECURITY CLASS. (of this report) Unclassified	
16. DISTRIBUTION STATEMENT (of this Report) Approved for public release; distribution unlimited.		
17. DISTRIBUTION STATEMENT (of the abstract entered in Block 20, if different from Report)		
18. SUPPLEMENTARY NOTES		
19. KEY WORDS (Continue on reverse side if necessary and identify by block number) Equipment Transmitters Monitoring Water quality Remote sensing		
20. ABSTRACT (Continue on reverse side if necessary and identify by block number) A field demonstration was implemented to deploy under actual field conditions several water-quality monitoring systems to determine their overall suitability and compatibility with the LaBarge designed remote water data transmitter. In addition, the study was to establish an information base upon which decisions could be made for selecting water-quality monitoring equipment capable of gathering reliable data for extended periods with limited maintenance. (Continued)		

D D C
RECEIVED
DEC 21 1977
F.

038 100

See

Unclassified

SECURITY CLASSIFICATION OF THIS PAGE(When Data Entered)

20. ABSTRACT (Continued).

Results of the investigation revealed that in long-term unattended situations, equipment operation was unsatisfactory. But in short-term deployments with sufficient attention being given to calibration techniques, the equipment rendered satisfactory results.

The operational environment has a significant effect on data reliability and equipment maintainability. Even though the data were inconclusive, there were indications that turbidity and water temperature and currents affected the accuracy of the measurements.

Unclassified

SECURITY CLASSIFICATION OF THIS PAGE(When Data Entered)

THE CONTENTS OF THIS REPORT ARE NOT TO BE
USED FOR ADVERTISING, PUBLICATION, OR
PROMOTIONAL PURPOSES. CITATION OF TRADE
NAMES DOES NOT CONSTITUTE AN OFFICIAL EN-
DORSEMENT OR APPROVAL OF THE USE OF SUCH
COMMERCIAL PRODUCTS.

ACCESSION for	
NTIS	<input checked="" type="checkbox"/> Section
DDC	<input type="checkbox"/> Section
UNANNOUNCED	<input type="checkbox"/>
JUSTI	
BY	
DISTRIBUTION/AVAILABILITY CODES	
Dist.	SPECIAL
A	

SUMMARY

The River and Reservoir Control Center of the Lower Mississippi Valley Division (LMVD) is presently developing a satellite-oriented water resources data collection network. The objective of this investigation was to deploy under actual field conditions several water-quality monitoring systems to determine their overall suitability and compatibility with the LaBarge designed water data transmitter. A water data transmitter was installed at a test site on the Mississippi River with the capability of being operated in either the ERTS (Earth Resources Technology Satellite) mode or the GOES (Geostationary Operational Environmental Satellite) mode, with the operational mode being primarily determined by LMVD.

Original plans called for the deployment of four different water-quality monitoring systems, two at a time, for test intervals of 2 weeks each in the Mississippi River. This was required because the transmitter can handle only eight analog and four digital input signals at a time. In addition, these water-quality monitoring systems would be tested in the laboratory prior to deployment in order to evaluate stability and accuracy specification published by the instrument manufacturers. From these bench tests, it was determined that only the Martek V and Hydrolab 6D12 units demonstrated sufficient stabilities and accuracies to justify further consideration and evaluation at the test site on the Mississippi River.

Once the two units were deployed, it was anticipated that the evaluation would require daily surveillance to detect deterioration in equipment performance and to recover water samples that could be analyzed in the laboratory at the U. S. Army Engineer Waterways Experiment Station in order to define an accurate baseline which would establish a common base for instrument comparisons.

Generally, it was determined that operational environments have a significant effect on data reliability and maintenance requirements. Even though the data were inconclusive, there were indications that turbidity, water temperature, and current affected the accuracies of the

measurements. The equipment deployed presented many questions pertaining to accuracy, reliability, and long-term unattended performance.

PREFACE

This report presents the results of an investigation to evaluate and select water-quality monitoring equipment based on overall suitability, as well as compatibility with the LaBarge, Inc. Water Data Transmitter. The study was performed by request of the River and Reservoir Control Center, U. S. Army Engineer Division, Lower Mississippi Valley (LMVD), and was formally authorized by letter dated 26 August 1975. Basic guidance and management during conduct of the study were given by Messrs. Warren L. Sharp and Charles Bradshaw, LMVD.

The study was conducted during the period of July 1976 to December 1976 by Mr. A. W. Ford, Environmental Effects Laboratory (EEL), U. S. Army Engineer Waterways Experiment Station (WES). The study was conducted under the direction of Mr. N. R. Francingues, Chief, Treatment Processes Research Branch, and under the general supervision of Mr. A. J. Green, Chief, Environmental Engineering Division, and Dr. John Harrison, Chief, EEL. The report was written by Mr. Ford.

Director of WES during the study and preparation of this report was COL John L. Cannon. Technical Director was Mr. F. R. Brown.

CONTENTS

	<u>Page</u>
SUMMARY	2
PREFACE	4
CONVERSION FACTORS, U. S. CUSTOMARY TO METRIC (SI)	
UNITS OF MEASUREMENT	6
PART I: INTRODUCTION	7
Background	7
Purpose and Scope	7
PART II: WATER-QUALITY MEASUREMENTS	10
pH	10
Dissolved Oxygen	11
Conductivity	11
Temperature	12
PART III: LABORATORY INVESTIGATIONS	13
Preliminary Tests	13
PART IV: FIELD INVESTIGATION	14
Instrument Deployment	14
River Conditions During Testing Period	14
Test Results During Low River Stage	16
Test Results During Rising River Stage	17
Analysis of Hydrolab Performance	20
Analysis of Martek Performance	20
Comparison of Data from the Different Transmission Modes	20
Measurement Accuracy	33
Instrument Response Time	34
PART V: CONCLUSIONS AND RECOMMENDATIONS	40
Conclusions	40
Recommendations	41
TABLES 1-5	

CONVERSION FACTORS, U. S. CUSTOMARY TO METRIC (SI)
UNITS OF MEASUREMENT

U. S. customary units of measurement used in this report can be converted to metric (SI) units as follows:

<u>Multiply</u>	<u>By</u>	<u>To Obtain</u>
inches	0.0254	metres
feet	0.3048	metres
pounds (mass)	0.4535924	kilograms

INVESTIGATION OF REMOTE WATER-QUALITY MONITORING
SYSTEMS FOR USE WITH GOES OR ERTS
WATER DATA TRANSMITTER

PART I: INTRODUCTION

Background

1. The River and Reservoir Control Center of the Lower Mississippi Valley Division (LMVD), in the fall of 1975, laid plans for the development of a fully automated water resource data collection system for the Lower Mississippi Valley that would employ the services of the Geostationary Operational Environmental Satellite (GOES) or the Earth Resources Technology Satellite (ERTS). Figure 1 shows the LMVD plan of development for an automated hydrometeorological and water-quality data collection network. Each station is equipped with a Water Data Transmitter (WDT) capable of storing water-quality and hydrometeorological data. Monitoring at remote sites is accomplished at prescribed intervals with transmission of data to either the GOES or the ERTS. These data are then relayed via radio telemetry to ground stations which disseminate the information to interested user agencies. In association with the development, the U. S. Army Engineer Waterways Experiment Station (WES) was requested by the River and Reservoir Control Center to prepare and submit a proposal to investigate currently marketed water-quality monitoring equipment for the purpose of evaluating the overall suitability and applicability of such equipment for use in conjunction with the WDT.

Purpose and Scope

2. The intent of the study was to establish an information base upon which decisions could be made for selecting water-quality monitoring equipment capable of gathering reliable data for extended periods

BEST AVAILABLE COPY

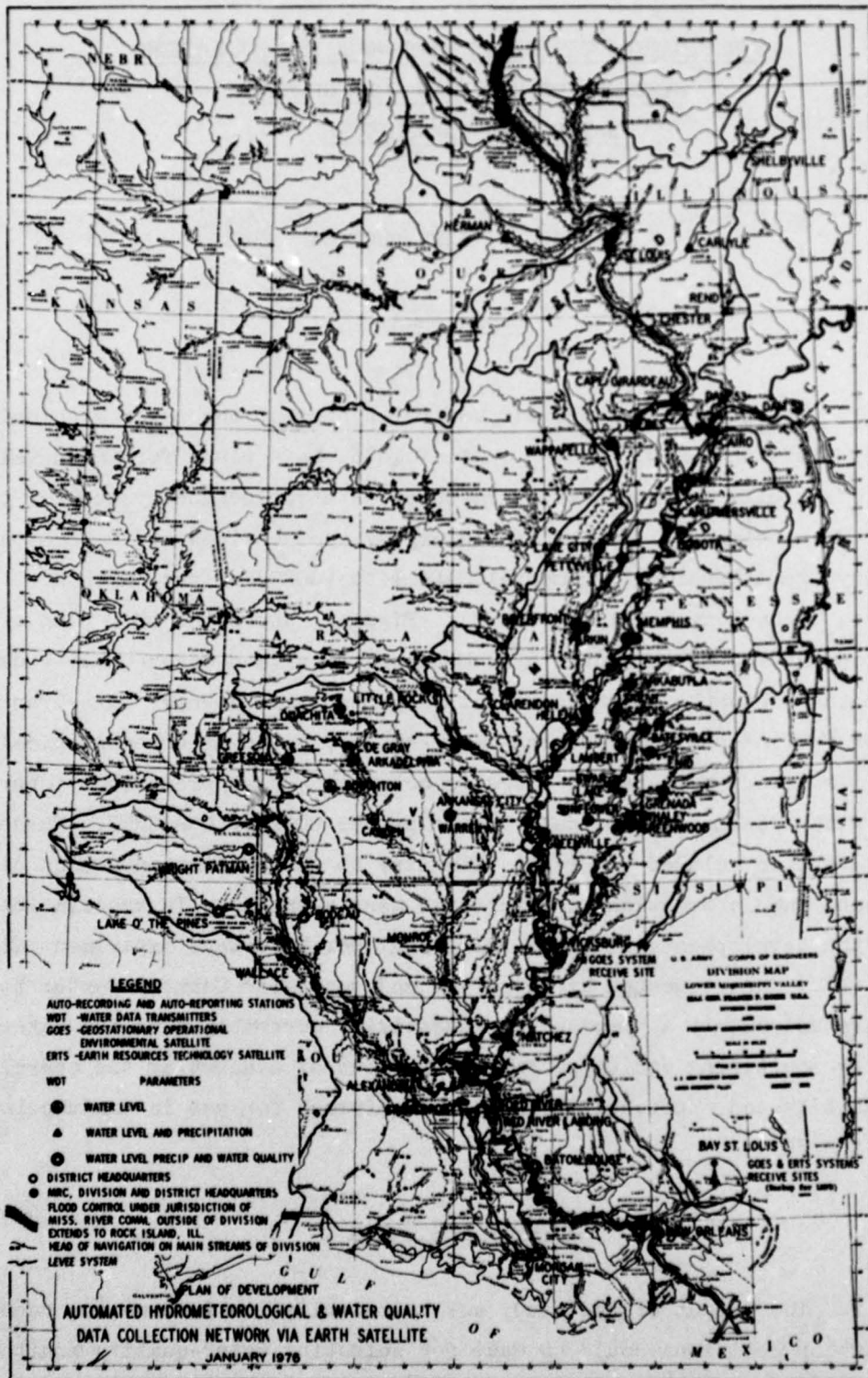

Figure 1. LMVD plan of development for an automated hydro-meteorological and water-quality data collection network via earth satellite

with minimal maintenance requirements. In addition, the study was to identify an "off-the-shelf" water-quality monitoring unit (or units) that would be electronically compatible with the WDT manufactured by LaBarge, Inc., in Tulsa, Okla., which is being used by LMVD and other Corps offices to monitor data via satellite.

3. Early in the study it was determined that at least four off-the-shelf water-quality units were available that were, in theory, compatible with the WDT. The four units tested were Martek V, Oceandata 101B, Hydrolab 6D12, and InterOcean 513D. They were evaluated based on the accuracy and response to each of the water-quality parameters measured, short- and long-term probe stabilities, and required frequency of mission essential maintenance. In plan, each unit was to have been subjected to a series of laboratory and field tests, but in actuality, as explained later in detail, only the Martek V and Hydrolab 6D12 were deployed in the field.

PART II: WATER-QUALITY MEASUREMENTS

4. Water-quality data are collected for many purposes. For instance, data requirements may be primarily established by geographic conditions, such as those that might be dictated in riverine, estuarine, or reservoir applications, or by scientific or judicial considerations, such as those established by regulatory, monitoring, baseline, and research guidelines. The scope of work of this study did not permit a detailed investigation of all water-quality parameters, but it did allow a cursory evaluation of the more significant or basic ones. Comparison of the pertinent physical and electrical characteristics of the four units that were evaluated is given in Table 1. Table 2 is a listing of normal measurement ranges, calibration methods, accuracies, and system responses of the parameters evaluated in this study. Other important operational considerations are presented for informational purposes. A brief description of the importance and significance of the parameters evaluated is presented in the following paragraphs.

pH

5. One of the fundamental water-quality parameters is pH. It is a term used rather universally to express the intensity of the acid or alkaline condition of a solution and is a factor that must be considered in chemical coagulation, disinfection, water softening, corrosion control, and sewage and industrial waste treatment employing biological processes. It gives a measure of hydrogen ions present in solution and is but one of a family of ion-selective measurements available for water-quality evaluation. It is almost universally measured by use of a glass electrode filled with a definite acidic electrolyte. This probe, used in conjunction with a standard calomel reference probe, produces an electromotive force proportional to pH units. Technology of the instruments evaluated is such that a user could expect accuracies of ± 1 percent. It might be emphasized that this accuracy is only attainable by calibrating the instruments prior to usage and by validating the calibration after the data have been collected.

Dissolved Oxygen

6. Dissolved oxygen (DO) measurements generally provide indications of the degree of pollution caused by organic compounds undergoing biological degradation. Since aerobic and anaerobic conditions are ubiquitous in nature, it is highly advantageous that conditions favorable to aerobic organisms be maintained. Thus, DO measurements are vital for ascertaining aerobic conditions in natural waters that receive pollutional matter.

7. Dissolved oxygen concentration is measured using a membrane-covered, passive polarographic probe. The partial-pressure proportional output signal of the probe is automatically corrected for variations of oxygen solubility and membrane permeability with temperature to provide an indication either in parts per million (by weight) or milligrams per litre (by volume) of DO. Accuracies of ± 1 percent are attainable if the same precautions are taken with calibration procedures as mentioned previously.

Conductivity

8. The conductivity of a solution is a measure of the total concentration of ions in the solution. As such, conductivity is closely related to other parameters that generally vary with ion concentration. Notable examples are salinity, chlorinity, total ionic strength, total dissolved solids, and oxygen solubility (salting out).

9. Chemically, seawater is commonly described in terms of its salinity (roughly, total salt content). The total salt content of seawater varies considerably, but the relative amounts of the major constituents remain nearly constant. This is another way of saying that the ion population in seawater varies in number but not in kind. Because of this, a one-to-one relationship exists between the salinity of seawater and its conductivity. Using this relationship, salinity can be determined from a quick electrical measurement rather than from a lengthy chemical analysis. Chlorinity (halogen content of seawater) is

similarly proportional to salinity, since salinity = $1.81 \times$ chlorinity. Assuming that the relative ionic composition of seawater is more or less constant, then a correlation between conductivity and ionic strength can be deduced.

10. The range of conductivities encountered in natural waters is very great, extending from a few micromhos per centimetre in glacial streams to approximately 60,000 μ mhos/cm in seawater and to even higher values in brine springs and wells. Therefore, to attain maximum accuracy from the equipment, the range of the particular measurement must be determined.

Temperature

11. Accurately monitoring temperature is the singularly most important instrumentation task necessary to produce valid water-quality data. It becomes so not because of the measurement itself but because other water-quality parameters are critically dependent on temperature. For greatest accuracy the maximum temperature span should be 0° to 40°C . The present state of the art of equipment will furnish data that are accurate to within $\pm 0.5^{\circ}\text{C}$.

PART III: LABORATORY INVESTIGATIONS

Preliminary Tests

12. Prior to placing the water-quality monitoring units in the field, laboratory procedures were performed to calibrate the four systems. Only two units, Martek and Hydrolab, were successfully calibrated. The others, Oceandata and InterOcean, would either not stabilize on one or more parameters within the 90-sec warm-up time provided by the WDT, or if the parameters did stabilize, calibration began to drift within 12 hr or less. Manufacturer's specifications on the Oceandata system recommended a minimum warm-up of 5 min for successful operation. This was not realized until after the equipment was in-house, for if it had been previously known, it could have been eliminated earlier. Therefore, it was decided that Martek and Hydrolab would be the units initially deployed in the river. Both units were operated during a 3-week period in the laboratory and both units remained in calibration. The data obtained using these two units are presented in Table 3. Also presented is a comparison of the monitored data with data obtained by standard analytical methods. Analytical data, L_A and L_B , were taken before and after the laboratory test period. There was a very close correlation in the calibration data between the units and analytical data. The water-quality monitors placed in an ideal environment of clean tap water at constant temperature in the laboratory demonstrated that the unattended equipment performed satisfactorily for 3 weeks.

PART IV: FIELD INVESTIGATION

Instrument Deployment

13. The water-quality instruments were located near the Vicksburg River gage site so that the WDT used to monitor river stage and precipitation could be utilized for this study. A diagram of the equipment installation is presented in Figure 2.

14. The instrument packages were suspended from a channel buoy, which is shown in Figure 3. The electronic cable from the packages were routed to electronic surface units located on the river bank; from here the signals were fed concurrently to a tape recorder and WDT. Figure 4 shows the deployment of the buoy in the river, and Figure 5 shows the instruments being installed on the buoy.

15. A plan of action was initiated that attempted to compare data from the water-quality monitors to data gathered and analyzed by classical methods. At hourly intervals data from the monitors were recorded on magnetic tape and simultaneously stored in the WDT. In addition, data were recorded from meters on the monitors coincidentally with the times samples were extracted from the river.

16. Deployment of the units in the field brought a number of problems into focus: changing river conditions, e.g., water temperature, river currents, turbidity, and river level; problems associated with the monitoring systems; and problems with the WDT. The first two items will be discussed in subsequent paragraphs.

River Conditions During Testing Period

17. At the time of initial deployment on 20 October 1976 the river stage was low and falling, turbidity was low, and the river current was moderate. The profile of the river bottom when the instruments were placed is depicted in Figure 6. At the time the profile was taken the river state was 10.2 feet.* Subsequently, during the test the stage

* A table of factors for converting U. S. customary units of measurement to metric (SI) can be found on page 6.

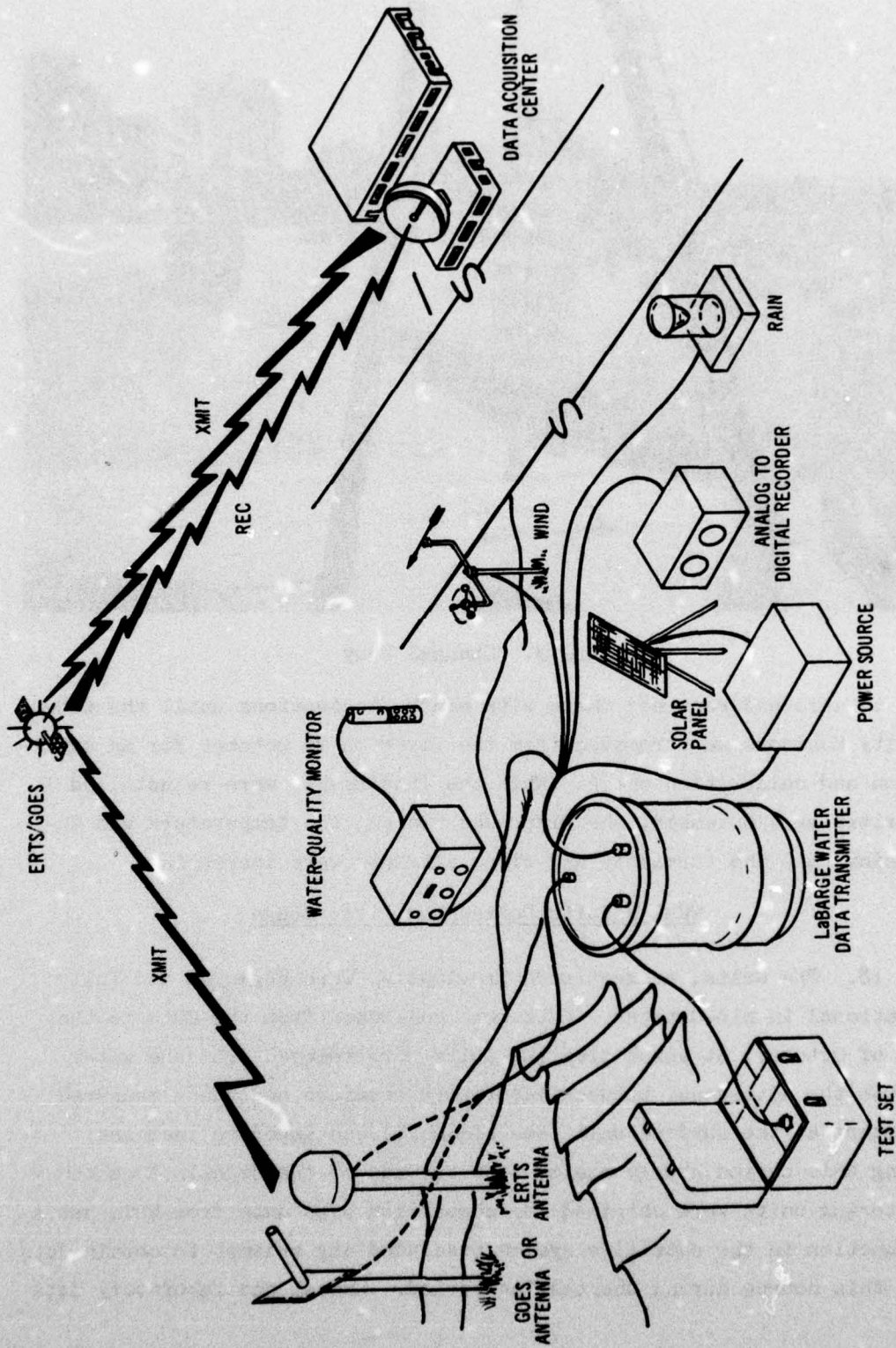

Figure 2. Typical ERTS/GOES water data transmitter installation

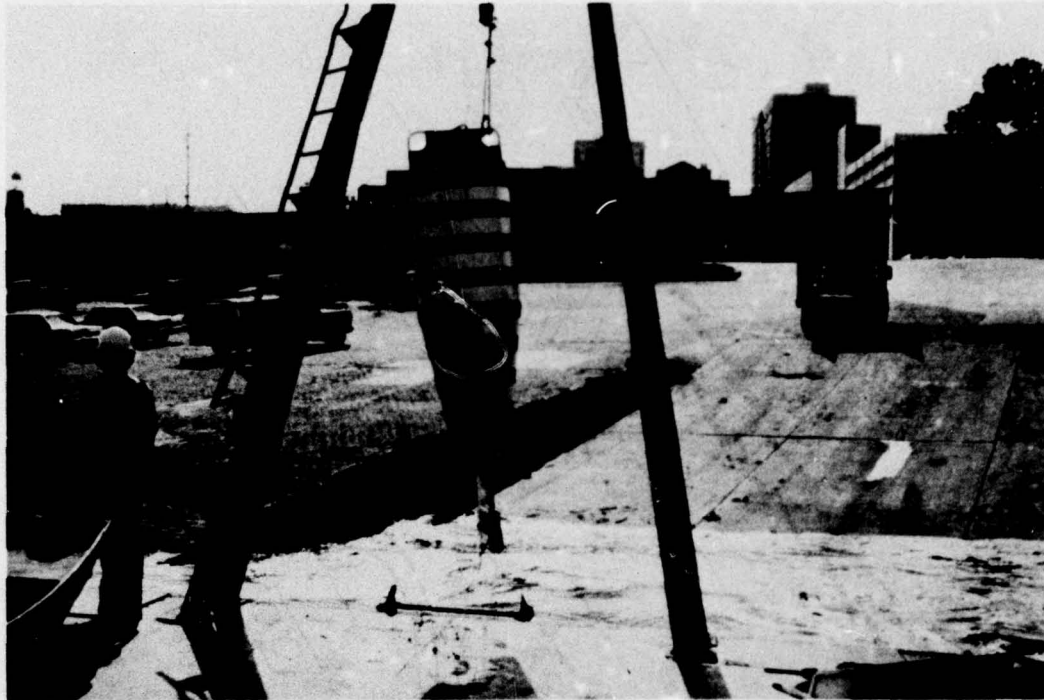

Figure 3. Channel buoy

fell to zero and remained there with minor fluctuations until the water-quality monitors were removed from the river on 26 October for an examination and calibration check. When the instruments were reinstalled in the river on 4 November, the river was rising, the temperature was decreasing, and the turbidity and river currents were increasing.

Test Results During Low River Stage

18. The units, as mentioned previously, were deployed and fully operational in mid-October. Data were collected from the 20th to the 26th of October, at which time the units were removed from the water because the divergency between laboratory readings and those measured by meters at the surface unit (see Figure 1) continued to increase. During this period hourly analog tape records of the signals from the monitoring units were obtained for comparison with data from WDT, but a malfunction in the satellite system precluded any attempt to obtain data from this source during the testing period. Manual and laboratory data

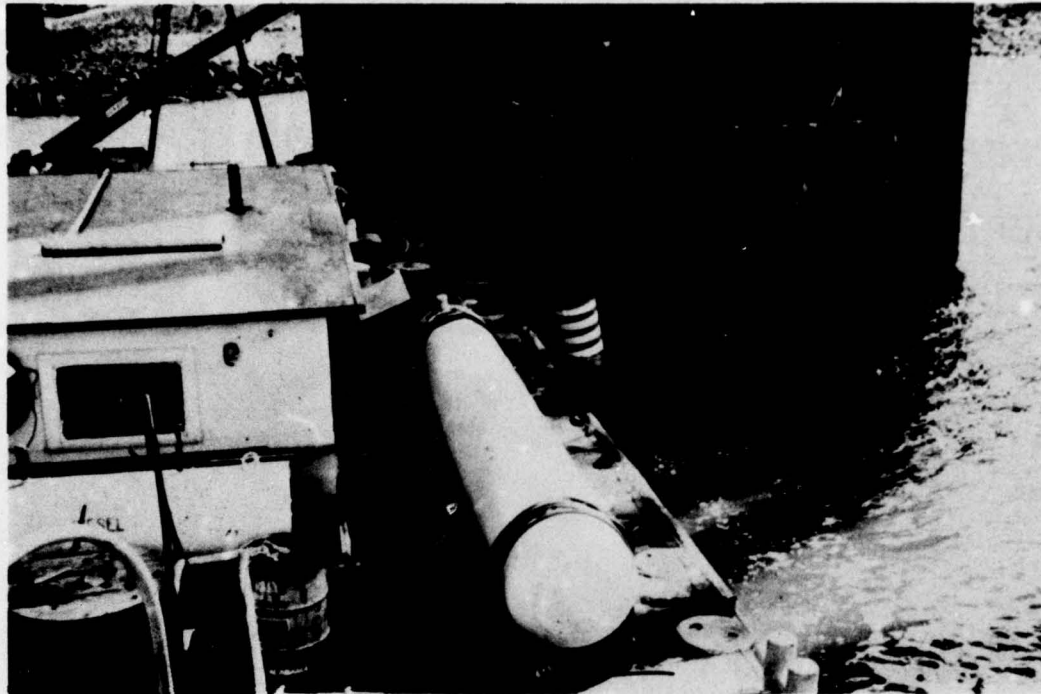

Figure 4. Buoy deployment

gathered during this period are presented in Table 4. From the table, it can be seen that the Martek and Hydrolab DO and pH measurements began to deviate from laboratory results in a very short time, whereas the conductivity and temperature measurements agreed rather closely and data gathered hourly verified these findings. There was one problem which was unassociated with the water-quality monitors. Tape data from the Hydrolab conductivity were rendered valueless because of a malfunction in the tape recorder. These problems prompted the removal of the units from the river for investigation of the problem areas.

19. From the laboratory evaluation, it was determined that the Martek pH probe was inoperative, and, therefore, it was replaced. The Martek DO and Hydrolab DO and pH probes were recalibrated and reinstalled in their respective assemblies.

Test Results During Rising River Stage

20. On 3 November 1976 the units were reinstalled at the site and

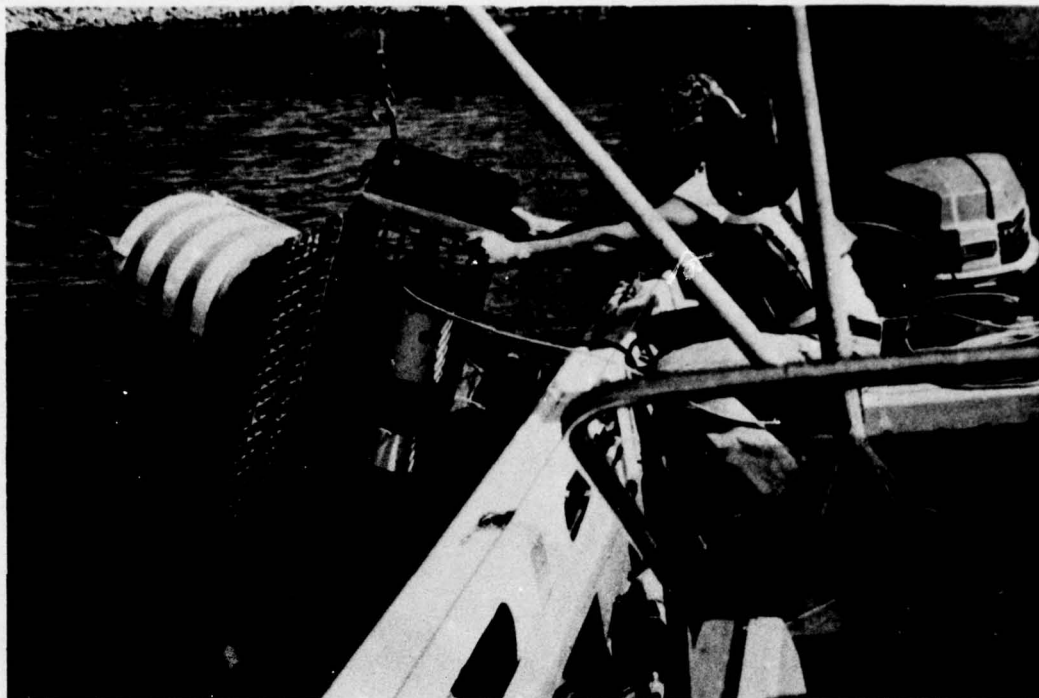

Figure 5. Monitor installation

results during this period are noted in Table 5. On the 4th of November it was noted that the Martek DO probe was malfunctioning as before and at this time it was replaced. However, due to an operator error the system was inadvertently shut down and no data were received on 4 November. Even though there were less identifiable hardware malfunctions during this period, inaccuracies in the data were still noted.

21. During this period there was also considerably more instability in the data than before and it is surmised (even though the evidence is inconclusive) that environmental conditions caused this phenomenon. Comparison of the data indicates considerably less agreement for the more turbid, higher current conditions. However, there are other environmental factors which may have influenced these data, for example, stage levels, algae growth, etc. These should be rigorously assessed in the expanded study. A program of larger scope would provide a systematic evaluation of a range of environmental conditions representative of those that might be encountered within the LMVD's overall operation.

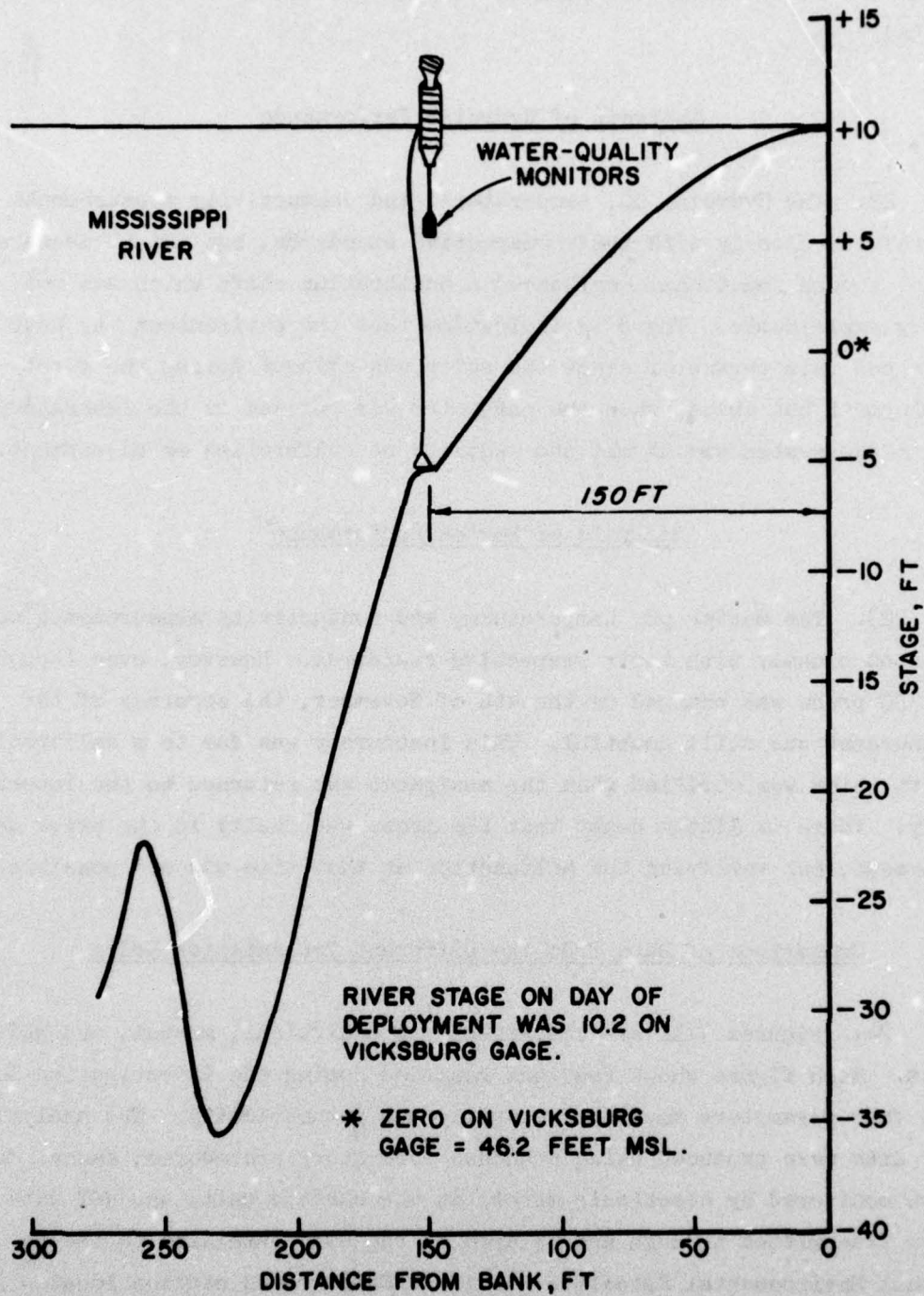

Figure 6. River bottom profile at test site

Data were successfully transmitted through the WDT-GOES link during this period.

Analysis of Hydrolab Performance

22. The Hydrolab DO, temperature, and conductivity measurements correlated closely with their respective standards, but the pH measurement, though functional, evidenced a calibration shift which was not fully explainable. There is indication that the environment may have affected this parameter since the shift was evident during the first deployment but absent when the parameter was checked in the laboratory where the system was normal and required no calibration or adjustment.

Analysis of Martek Performance

23. The Martek pH, temperature, and conductivity measurements correlated closely with their respective standards. However, even though the DO probe was changed on the 4th of November, the accuracy of the measurement was still doubtful. This inaccuracy was due to a calibration shift which was verified when the equipment was returned to the laboratory. There is little doubt that the probe was faulty in the prior deployment, but verifying the malfunction at that time was not possible.

Comparison of Data from the Different Transmission Modes

24. Figures 7-10 are comparisons of analytical, manual, and WDT data. Each figure shows readings recorded during the investigation for the four parameters monitored manually and automatically. The analytical data were produced using standard laboratory procedures; manual data were monitored by electronic meters at the surface unit; and WDT data were transmitted through and relayed by the GOES satellite to the National Environmental Satellite Service (NESS) ground station located in Wallops Island, Va. Originally, it was planned to use the United States Geological Survey (USGS) ground station located at the National Space

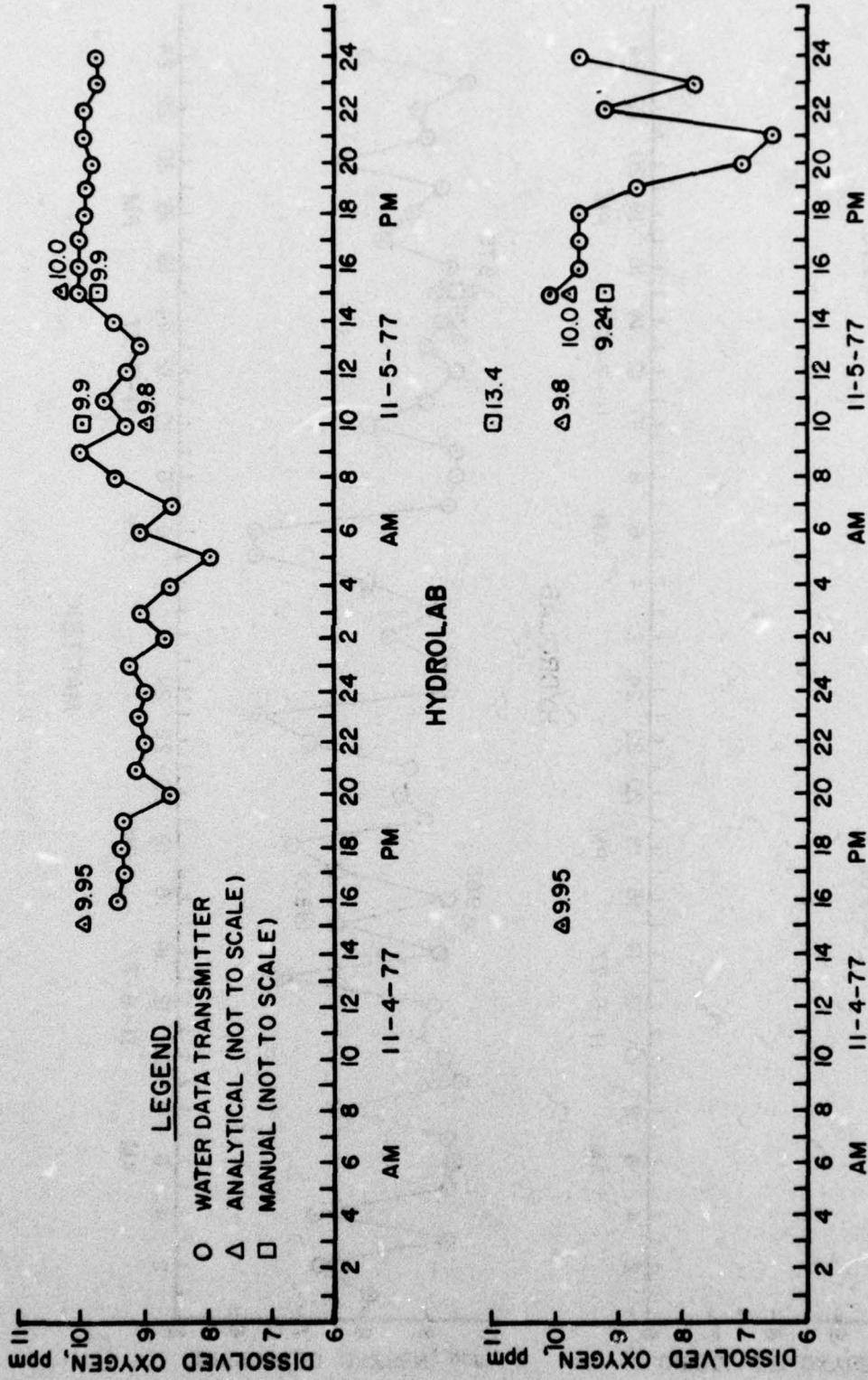

Figure 7. Dissolved oxygen data during rising river stage (sheet 1 of 3)

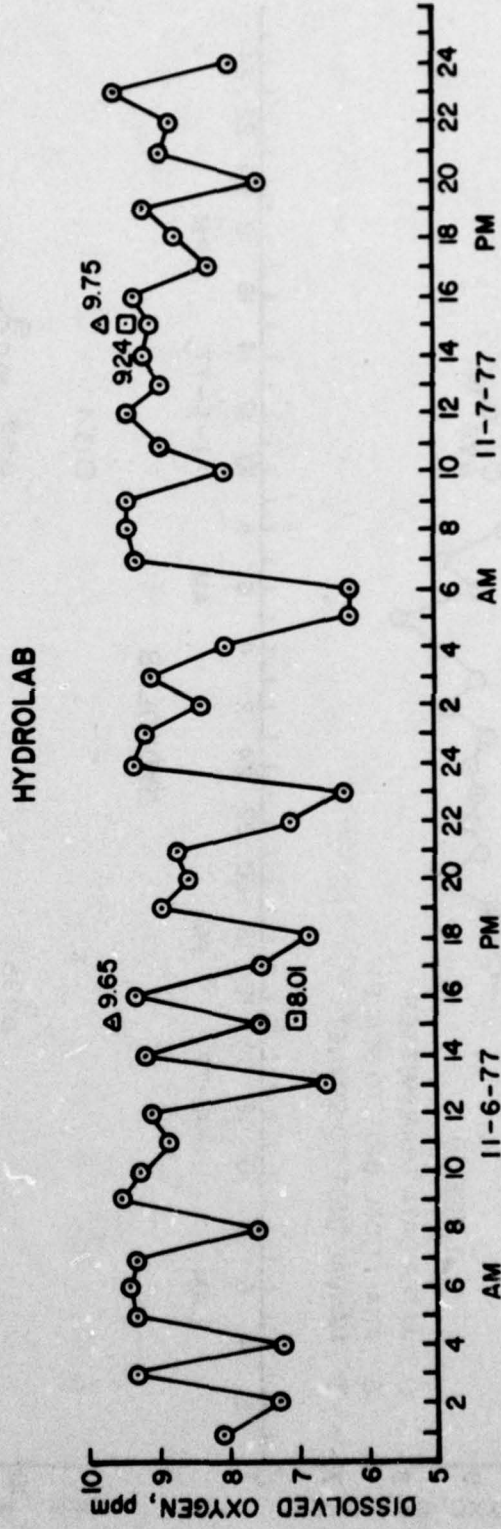
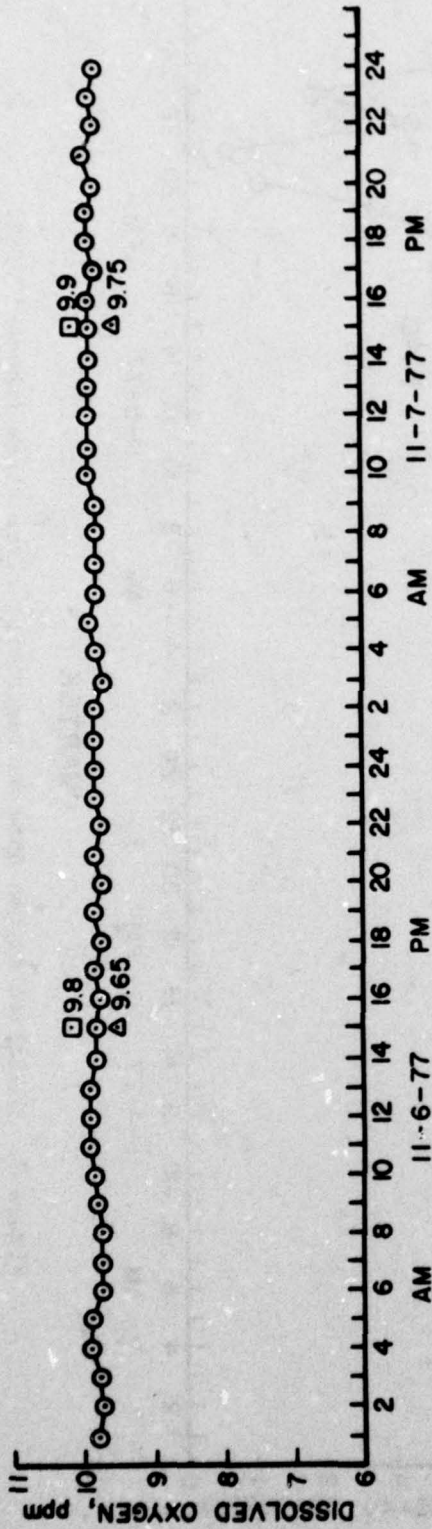

Figure 7 (sheet 2 of 3)

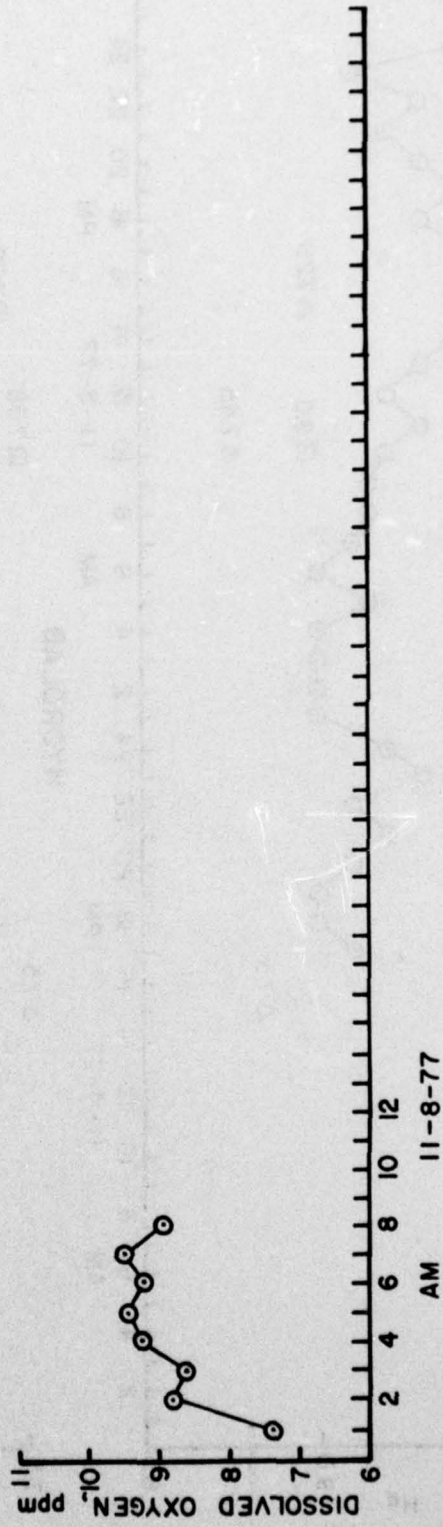
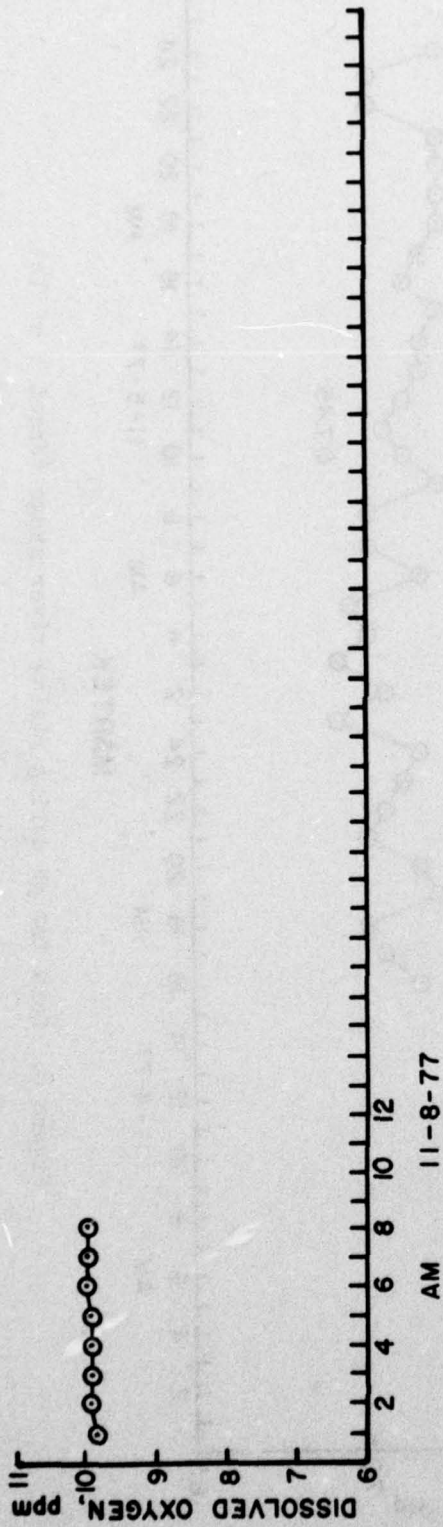

Figure 7 (sheet 3 of 3)

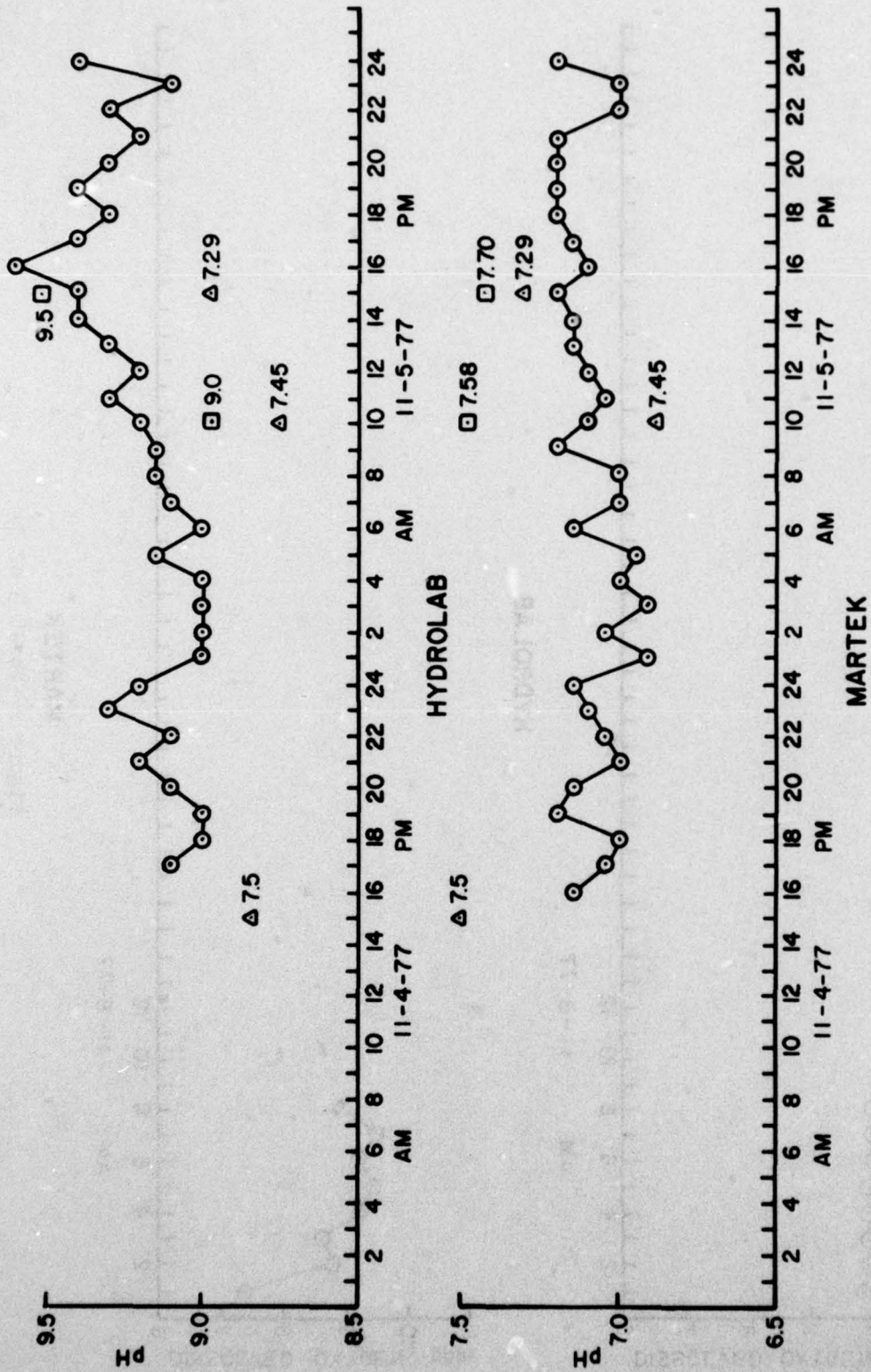
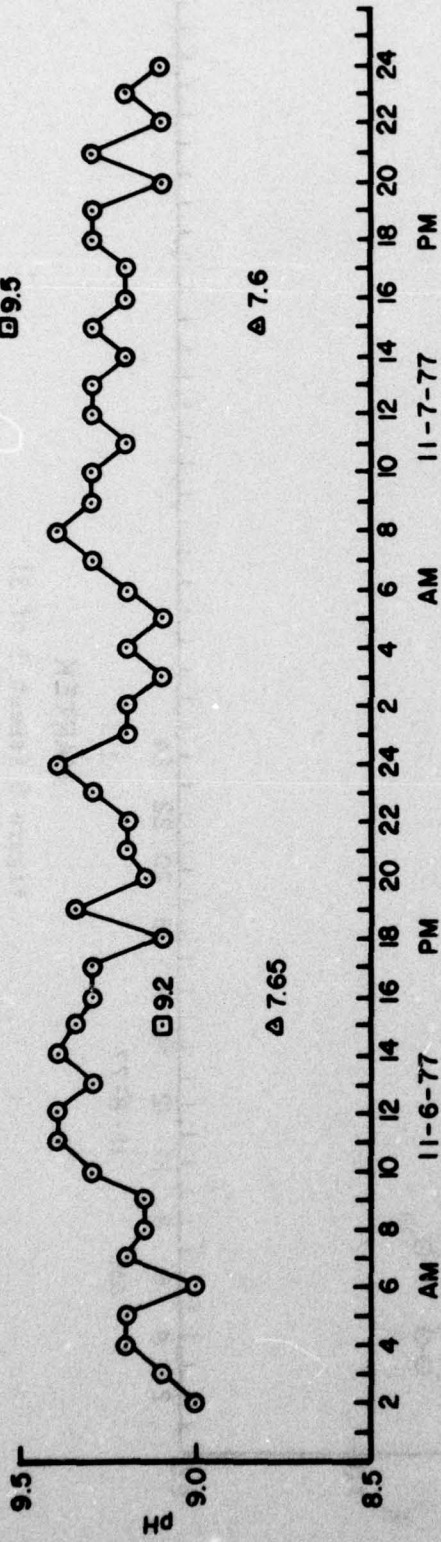
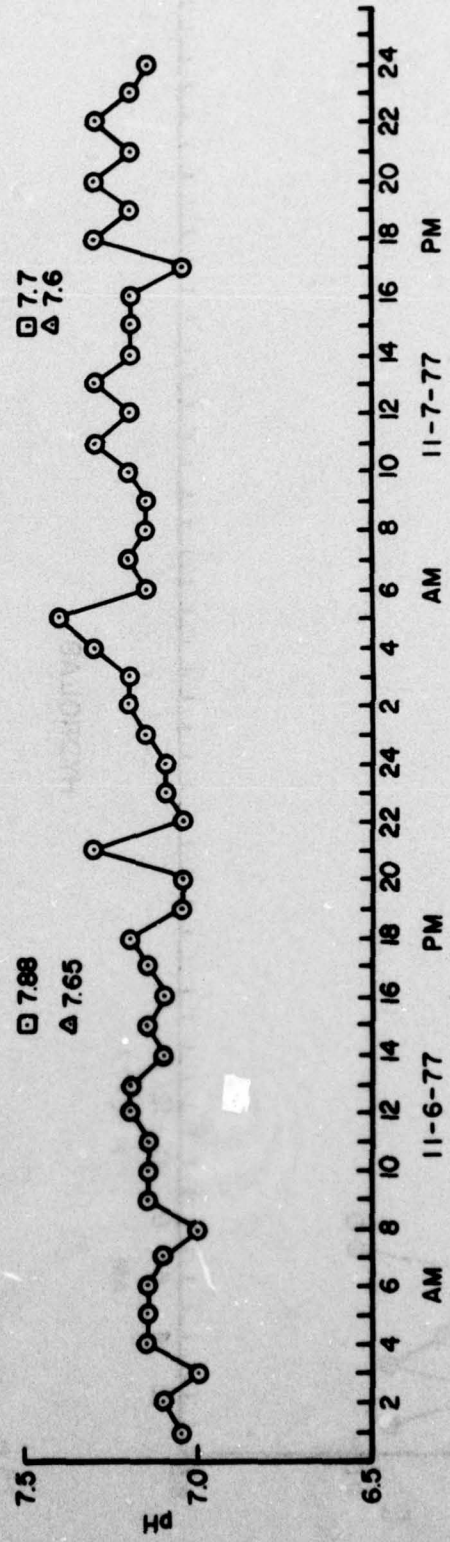

Figure 8. Data for pH during rising river stage (sheet 1 of 3)



HYDROLAB



MARTEK

Figure 8 (sheet 2 of 3)

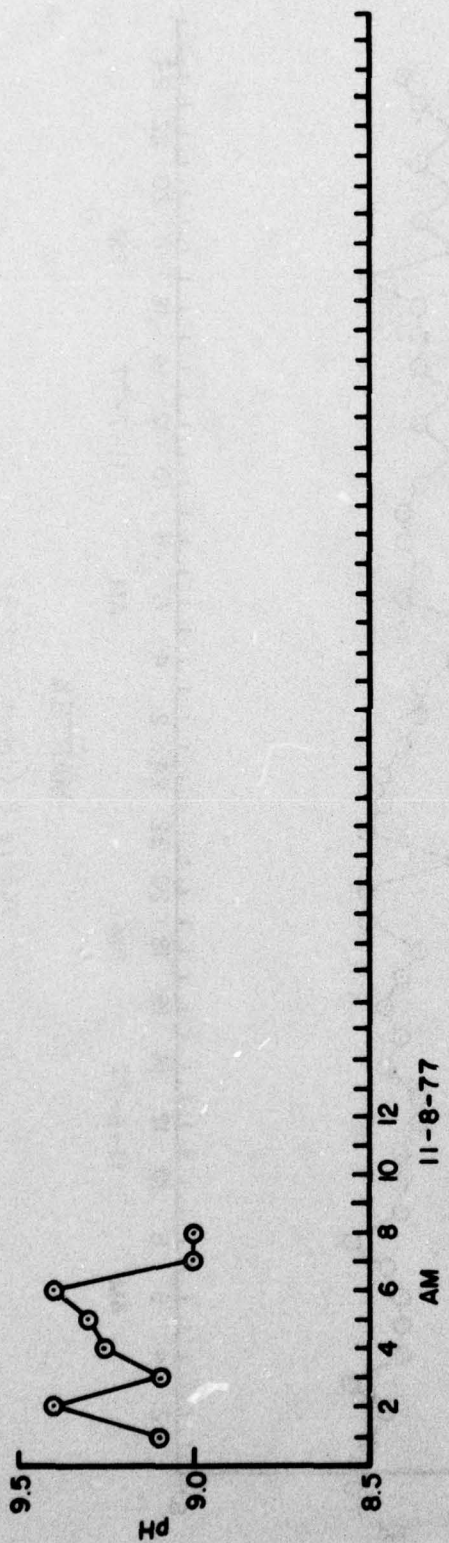

HYDROLAB

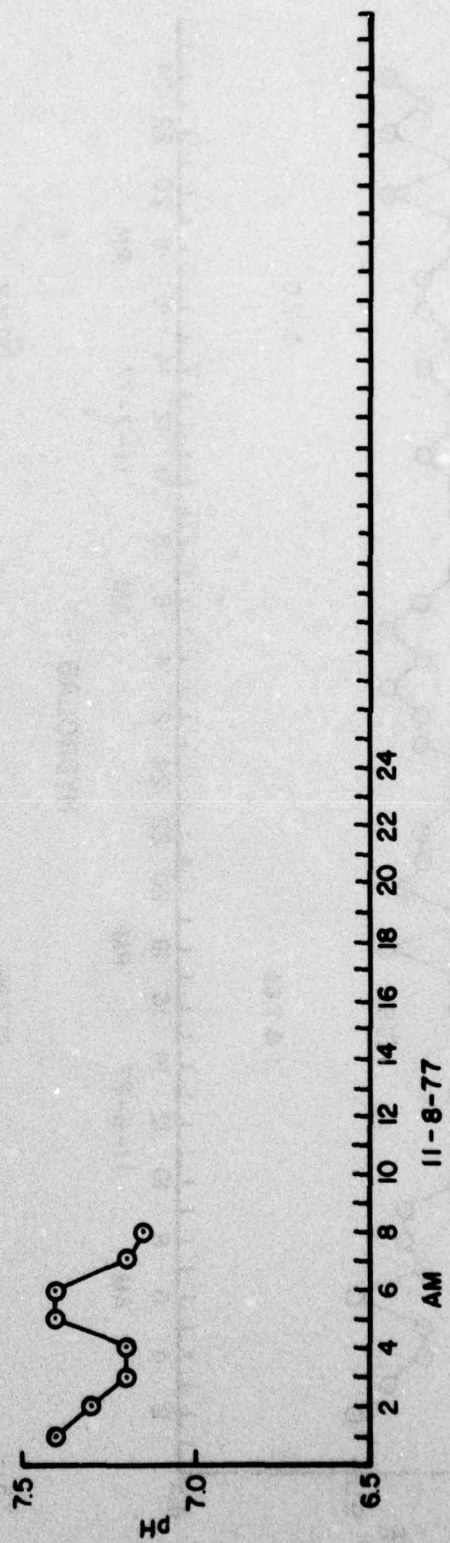

MARTEK

Figure 8 (sheet 3 of 3)

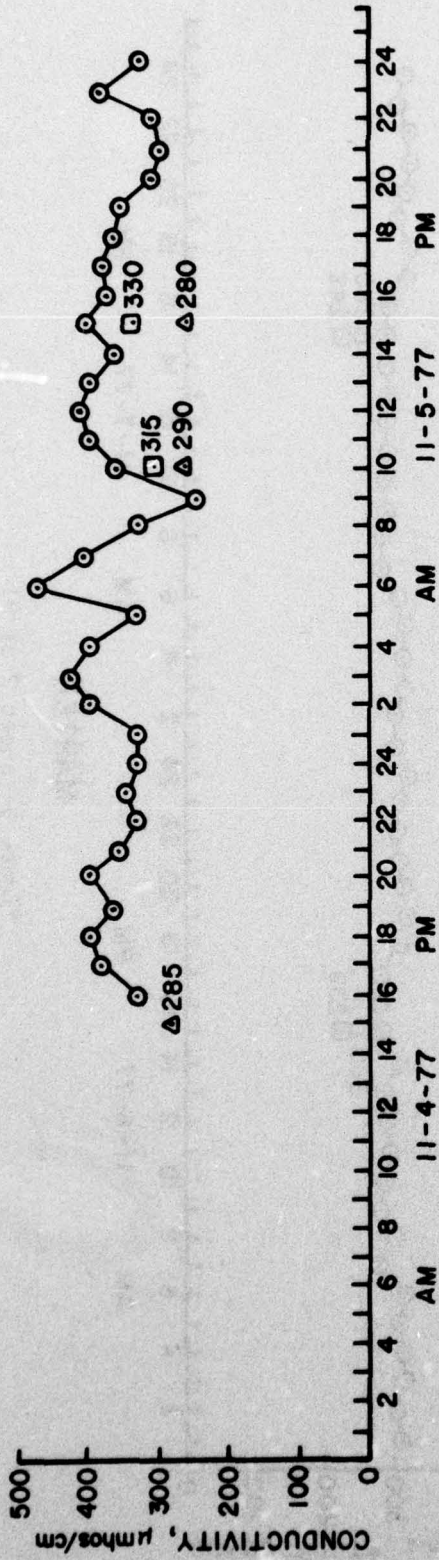

HYDROLAB

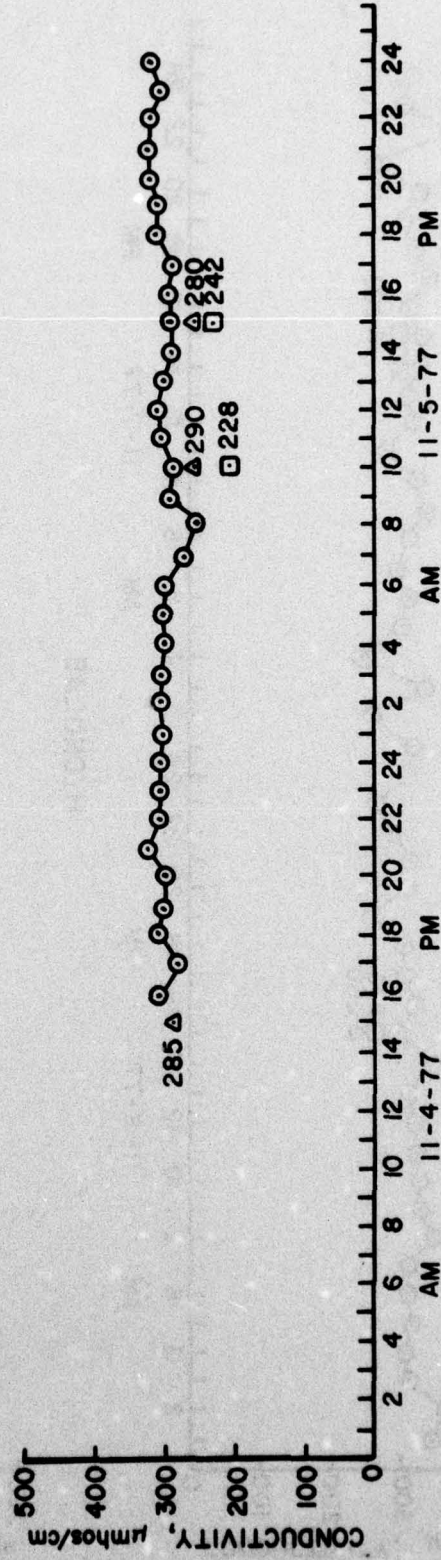

MARTEK

Figure 9. Conductivity during rising river stage (sheet 1 of 3)

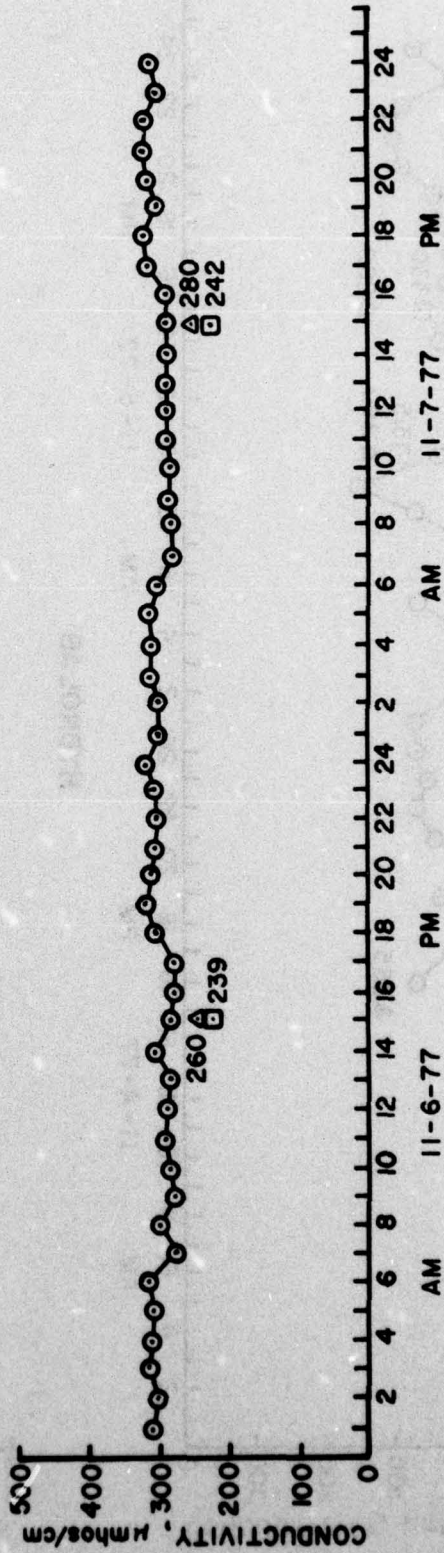
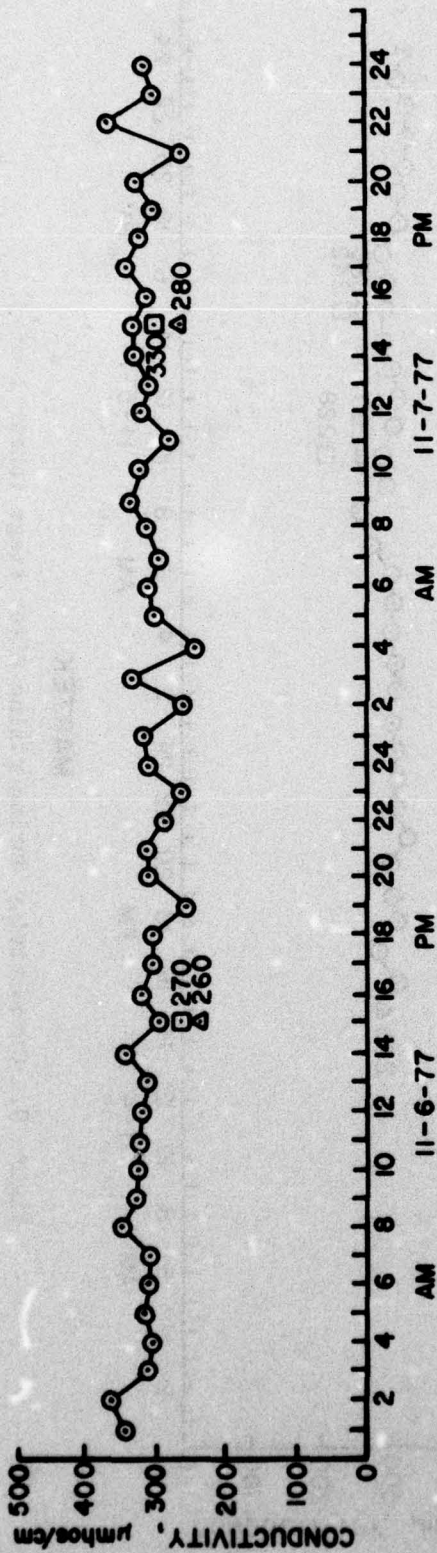

Figure 9 (sheet 2 of 3)

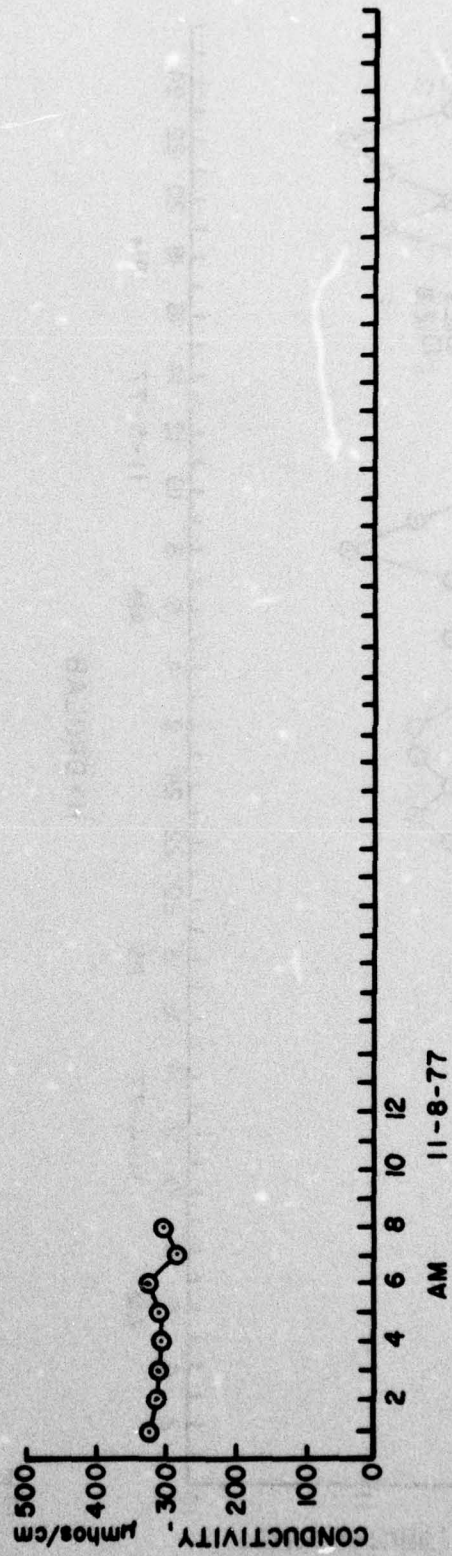
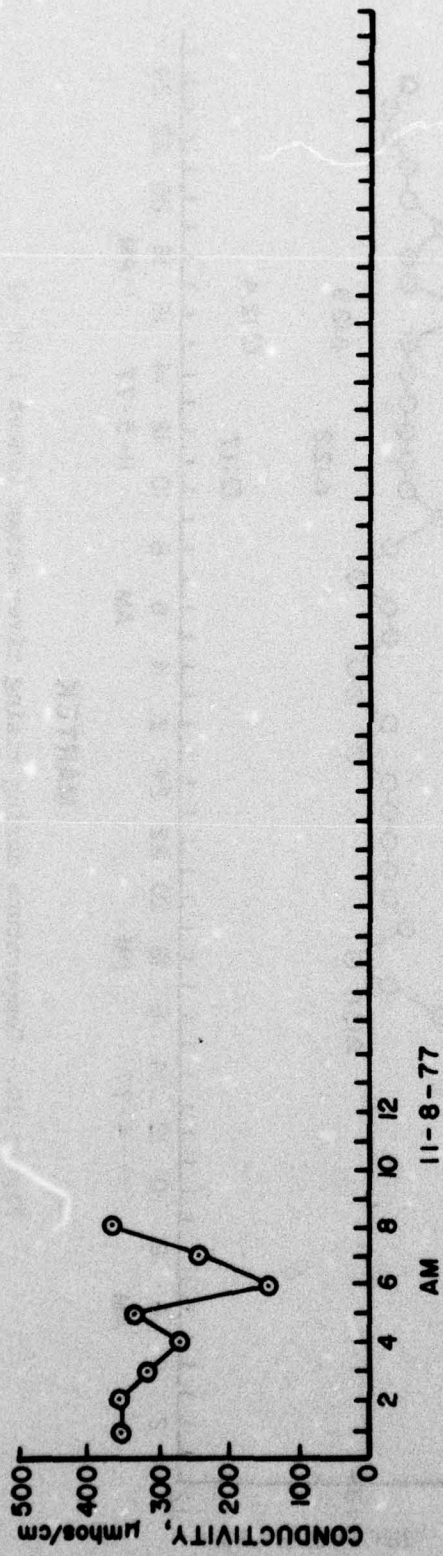

Figure 9 (sheet 3 of 3)

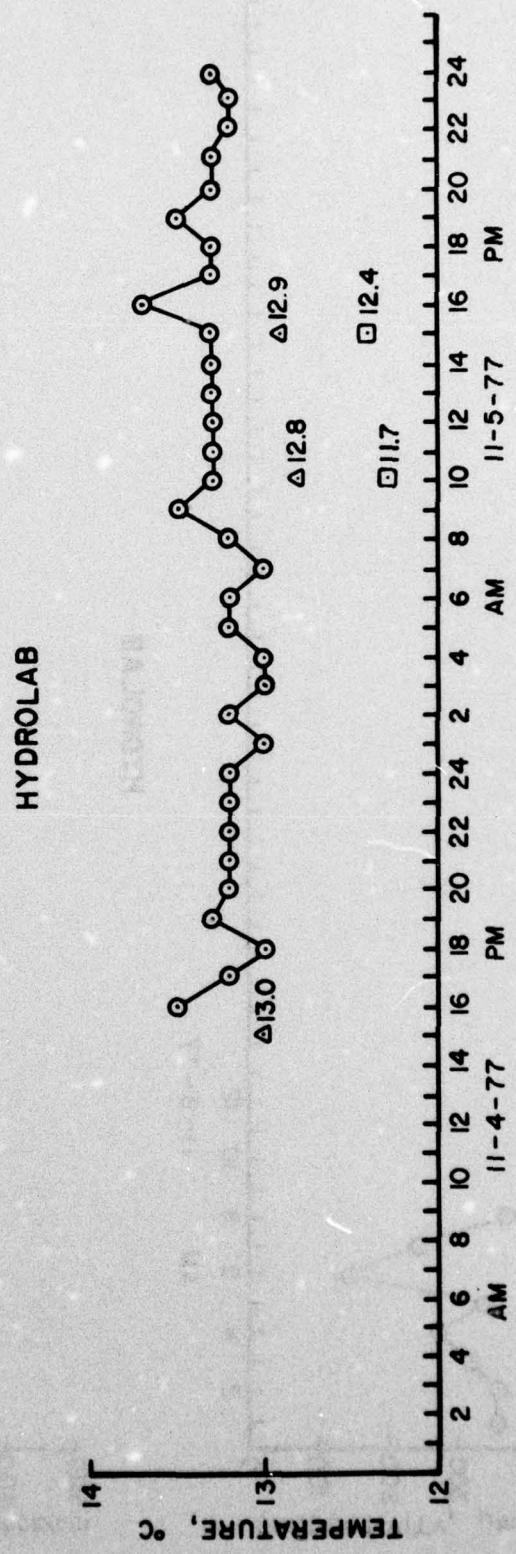
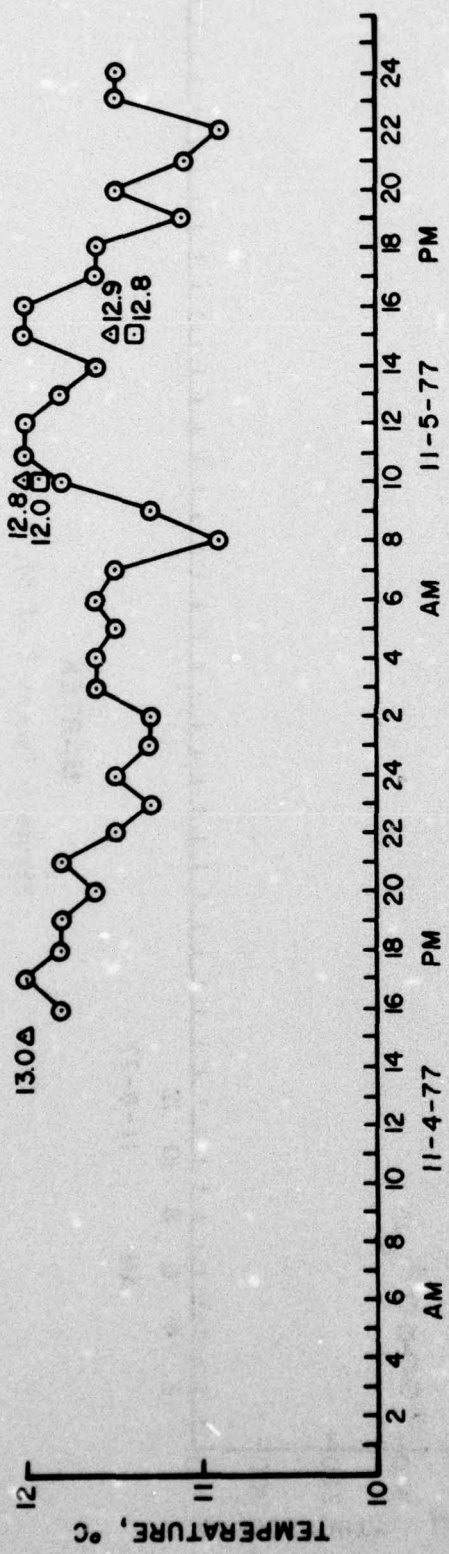
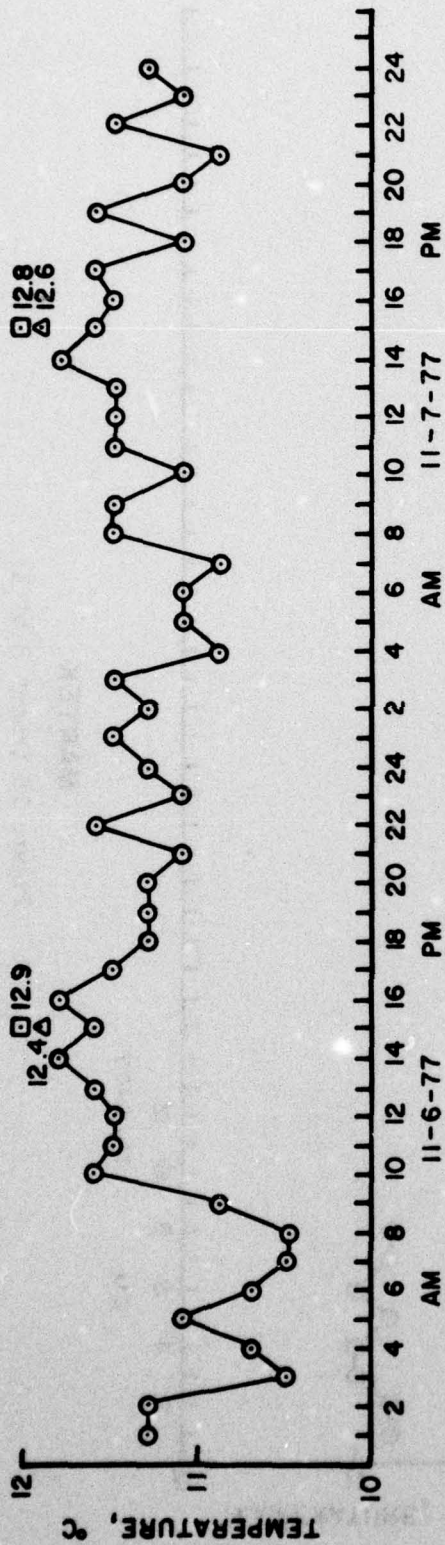
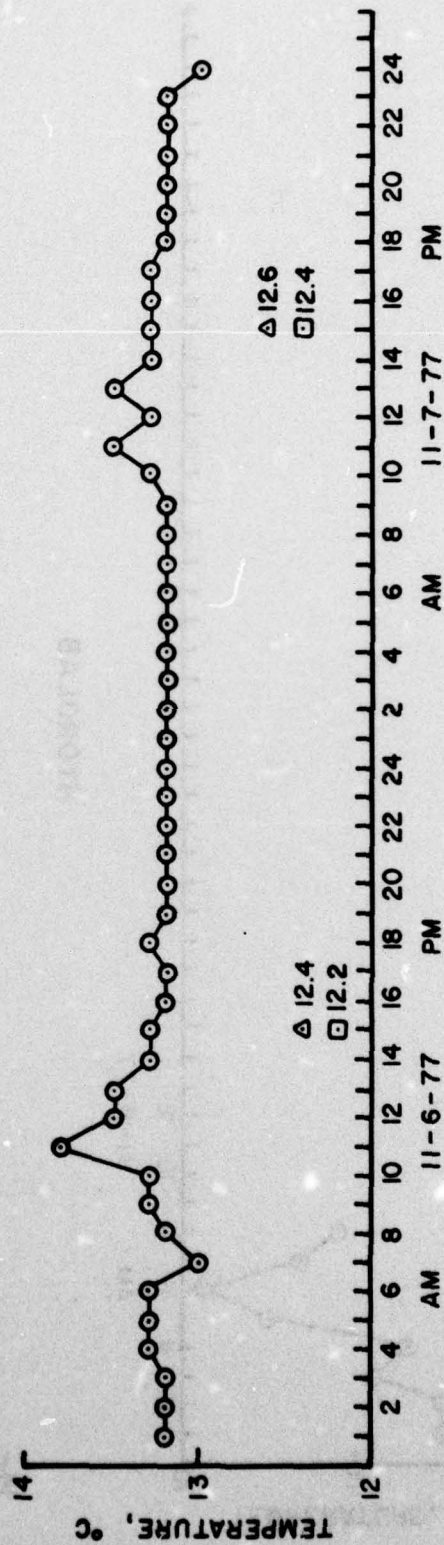

Figure 10. Temperature during rising river stage (sheet 1 of 3)



HYDROLAB



MARTEK

Figure 10 (sheet 2 of 3)

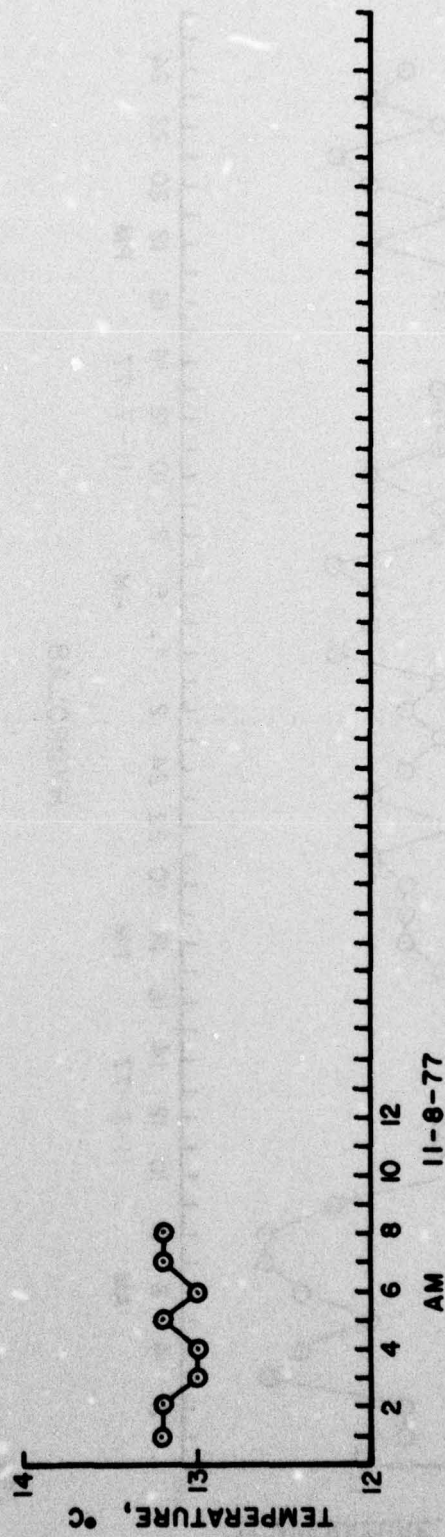
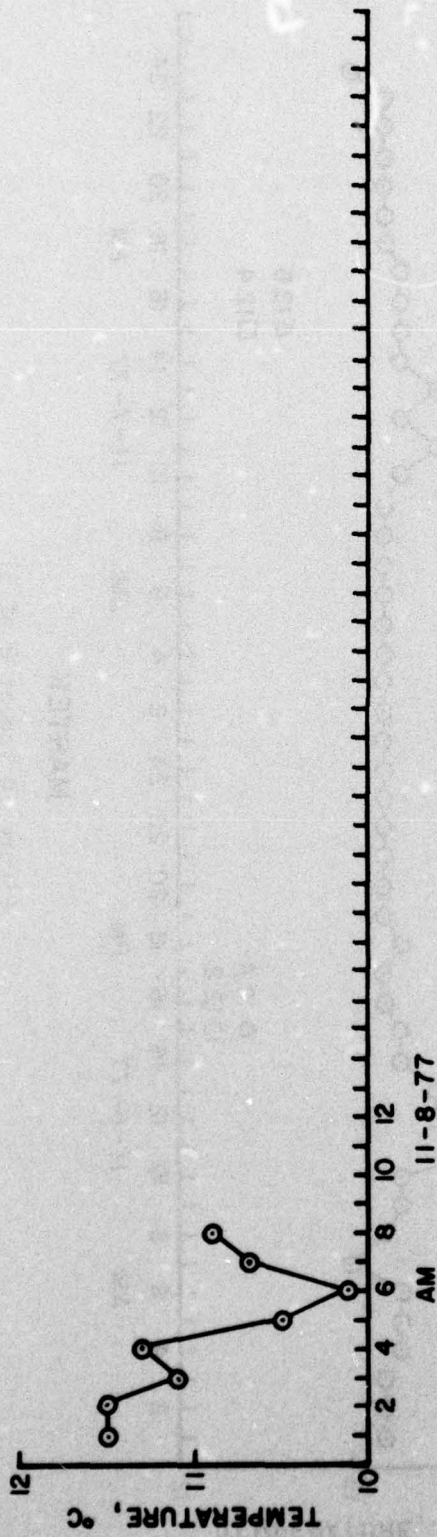

Figure 10 (sheet 3 of 3)

Technology Laboratory in Bay St. Louis, Miss. Due to repeated equipment malfunctions it was necessary to utilize the NESS data facility.

25. Data were gathered at hourly intervals except for the analytical (laboratory) data, which were taken once or twice a day between 0800 and/or 1600 hr. It was assumed that this diurnal sampling frequency was sufficient to establish enough baseline data for the data comparison. In addition, it was assumed that there would be very little variation in the hourly data. These assumptions were proven to be generally correct, but it became apparent that maintaining parameter calibration was difficult in an unattended data gathering operation. It is evident therefore that for future studies calibration techniques should be addressed in detail to ensure that the most accurate data within the limits of equipment capability are attained. Recommendations from the equipment manufacturers were universal in their approach to calibration: use standard buffer solutions to set prescribed parameter limits. This led, as mentioned earlier, to satisfactory results in the laboratory, but equipment reaction to field conditions was more critical. The scope of this study did not permit the determination of causes for degradations in equipment calibration; however, it may be attributed to silt deposition evident on all submerged surfaces, biological growths, mishandling of equipment, or mechanical defects.

26. An examination of the plots of test data reveals that the Hydrolab unit had roughly half the accuracy as did the Martek unit except for the Martek DO parameter which was very erratic. The data are inconclusive, but there is strong indication that the measurements are flow sensitive. Readings in the laboratory and in conditions of low river flows were very consistent but under the condition of increased flow, the scatter in the data increased markedly.

Measurement Accuracy

27. Using the baseline established by standard laboratory procedures, the accuracy of the Hydrolab DO measurements is 0.2 ppm. The Hydrolab pH data have accuracies of approximately 2.0, whereas the

Martek unit has an accuracy of 0.5. The error in the Hydrolab unit was caused by a shift in calibration. The Hydrolab conductivity data have accuracies of approximately 80 $\mu\text{mhos/cm}$, while the Martek unit exhibited an accuracy of approximately 20 $\mu\text{mhos/cm}$. Similarly, the temperature plots for both instruments show that the accuracy in the Hydrolab approaches 1°C , whereas the accuracy of the Martek unit is 0.5°C . Except for the Martek DO and Hydrolab conductivity measurements, the WDT data were very precise, but the data emphasize that calibration techniques are quite critical. Even though the values presented are precise representations of the sensor measurement, deviation of results from the "true" values is the measure of system accuracy. An important distinction between precision and accuracy is that accurate measurements are always precise, but the converse is not necessarily true. Generally stated, the accuracies as presented in published specifications by the equipment manufacturers for the water-quality monitoring packages were not verified.

Instrument Response Time

28. The rate at which sensors respond to the change in test variables is referred to as "response time." This is an indication of the time required for the sensor signal to follow a percentile of instantaneous full-scale change in the measured variable. Response time is an important characteristic and should be defined for each dynamic or static sensor deployed in water-quality investigations. Tests were performed in the field to determine the length of time a sensor took to exhibit stability for the parameters represented. Figures 11-14 are presentations of the responses of each of the sensors monitored during the testing period. Data were collected from each sensor at 10-sec intervals for 2 min. The 2-min period was deemed adequate because the WDT specification allows 90 sec nominally for stabilization of the transducers. These tests were indicative of the response times for the entire measuring system. Examination of the responses reveals that both the Martek and Hydrolab DO probes required about 60 sec to equilibrate.

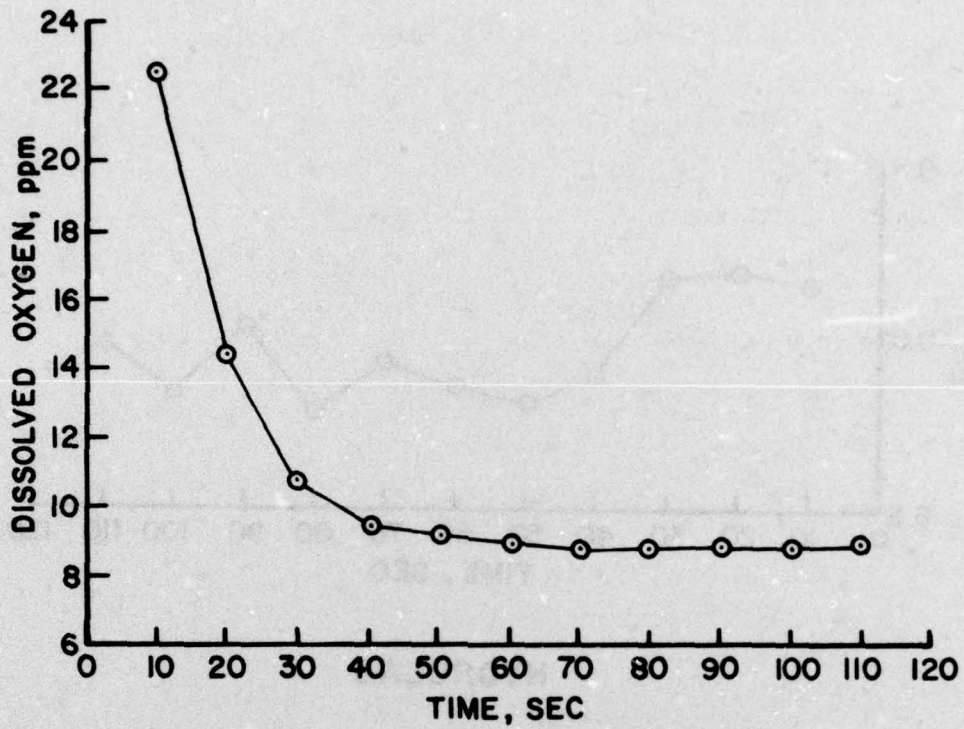

HYDROLAB

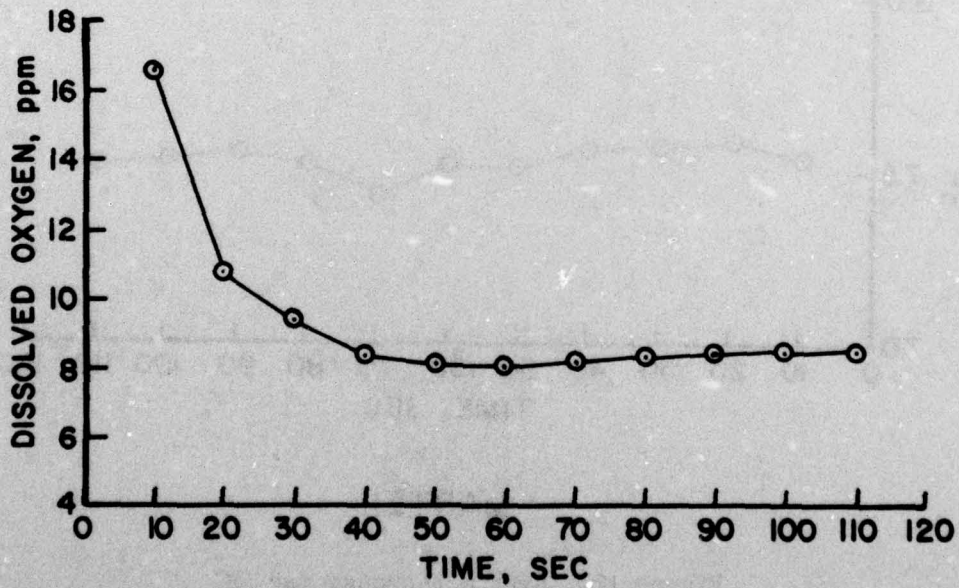

MARTEK

Figure 11. System response for DO

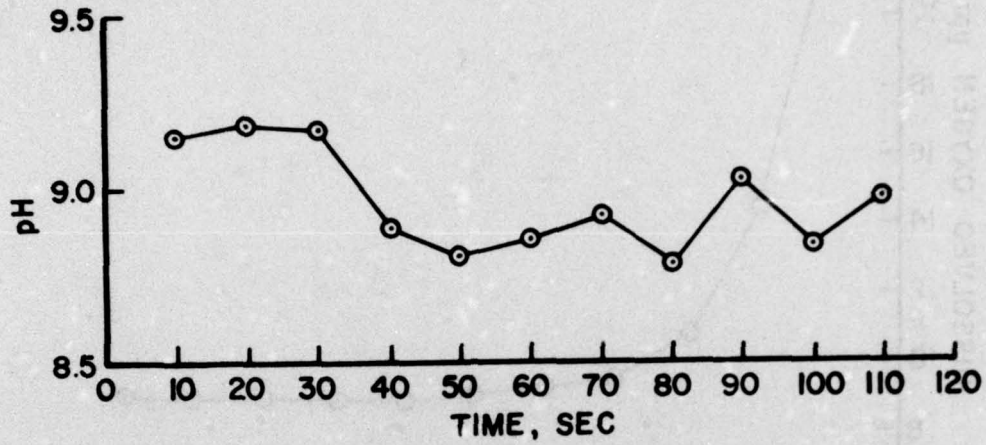

HYDROLAB

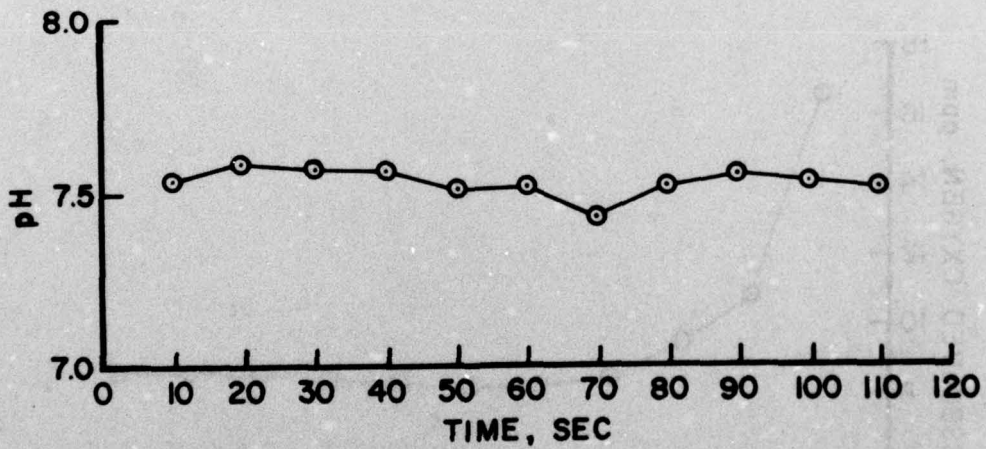

MARTEK

Figure 12. System response for pH

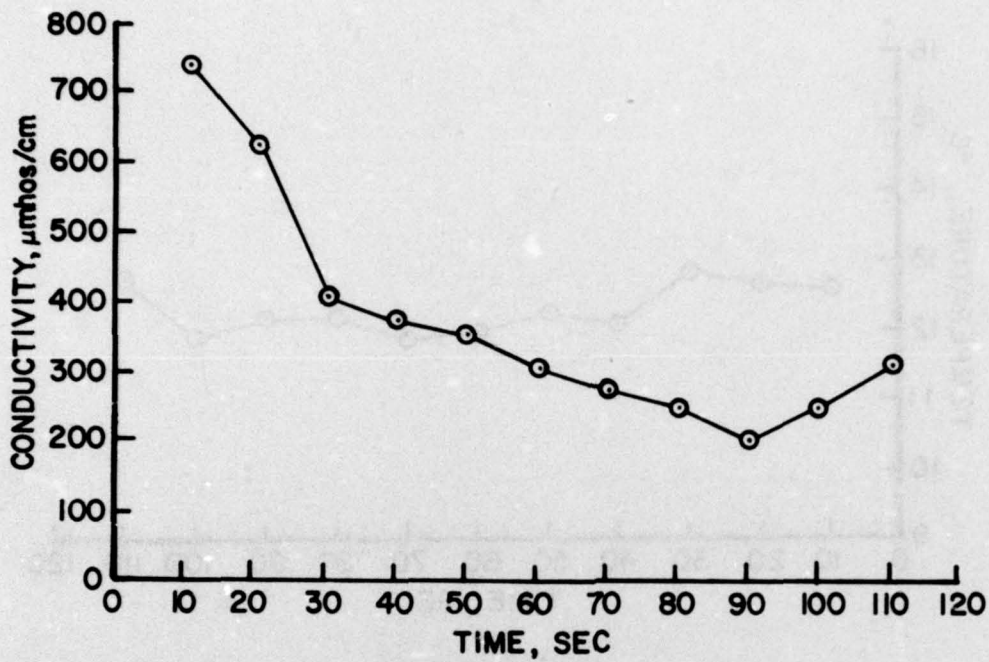

HYDROLAB

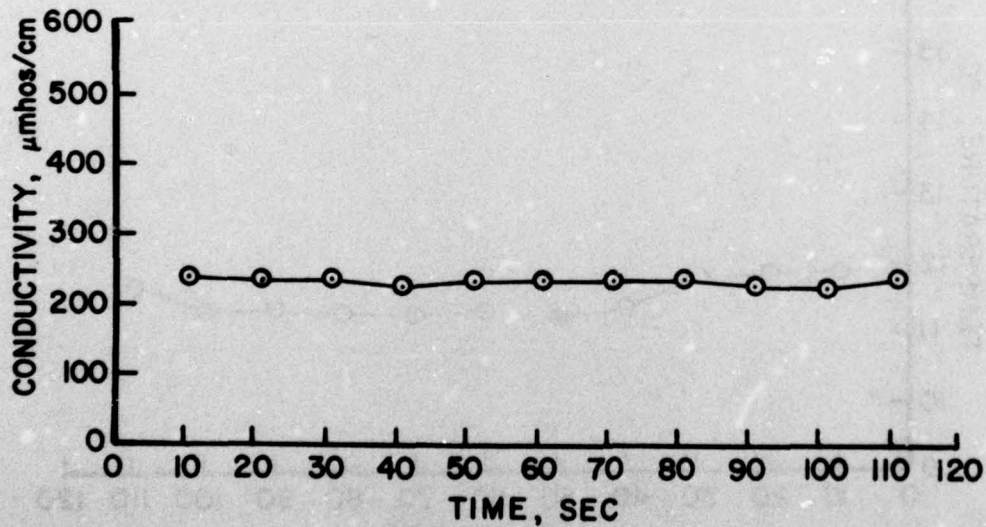

MARTEK

Figure 13. System response for conductivity

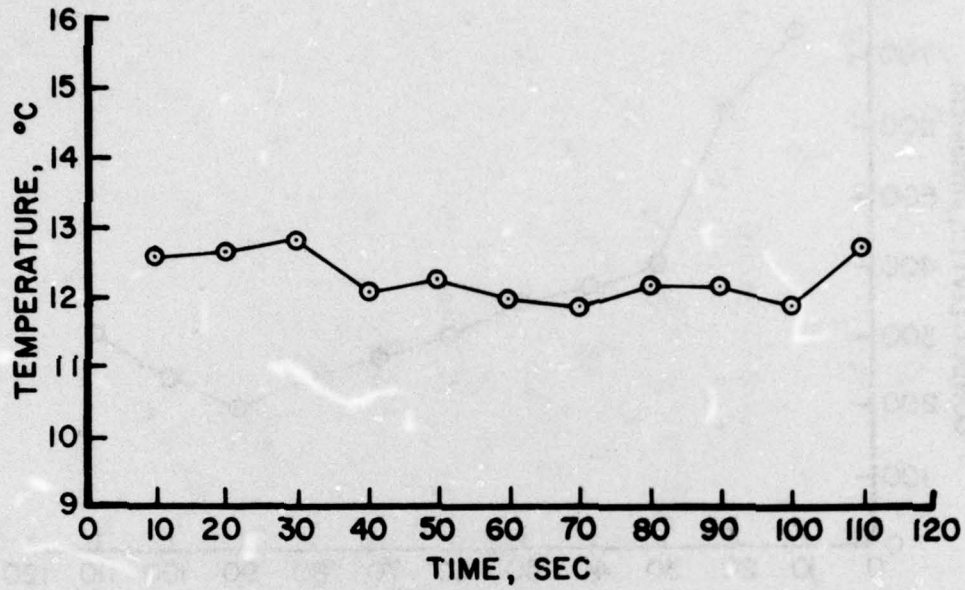

HYDROLAB

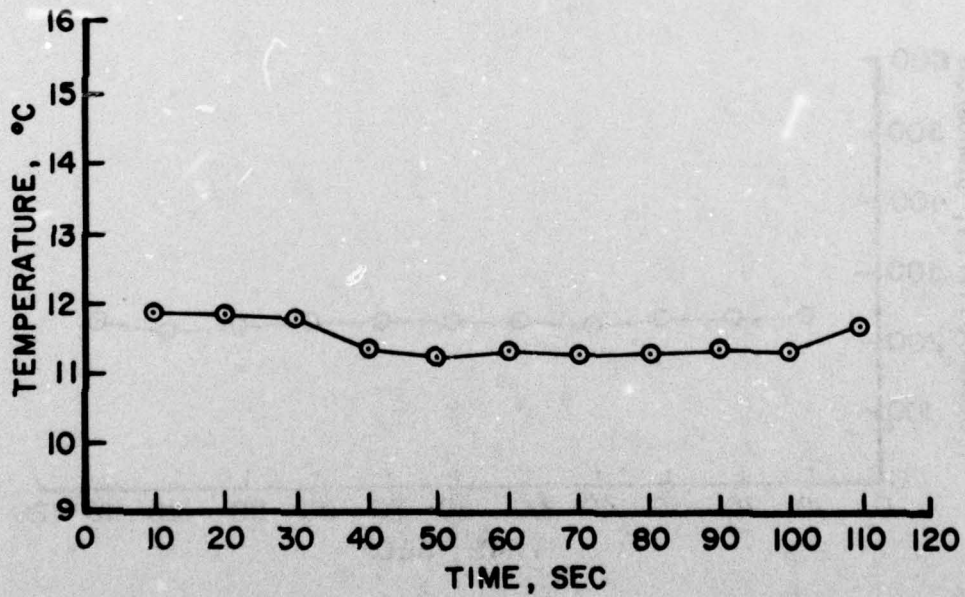

MARTEK

Figure 14. System response for temperature

The Hydrolab pH sensor, after the normally recommended time of 60 sec had elapsed, displayed pH output variations in excess of 0.2 between consecutive 10-sec intervals. Since pH can be assumed as being constant (within these environs) for such a short time frame, these variances are interpreted as equipment error. This value alone exceeds the total accuracy specified by the manufacturer by four times. An investigation of the same parameter for the Martek unit reveals similar output variations but only half as much, but this value still represents an error of over twice that specified by the manufacturer. Scrutiny of the Hydrolab conductivity histogram reveals that the sensor did not sufficiently equilibrate in the 2-min period; thus, an accurate assessment of response could not be made. This substantiates the findings as displayed in Figure 8, which illustrates that the Hydrolab measurement was more erratic than the Martek. Conversely, the Martek histogram was relatively stable over the 2-min data acquisition period; this was substantiated by long-term tests. Response tests for the temperature measurements displayed output variances in successive 10-sec measurements of approximately 0.5°C for both units. It might be noted that measurements took twice as long in the field to equilibrate as those taken in the laboratory. This indicates that the sensor's sensitivity and response to change were affected by the river environment.

PART V: CONCLUSIONS AND RECOMMENDATIONS

Conclusions

29. Completed laboratory and field investigations have revealed that there are a number of uncertainties involving field deployment of off-the-shelf water-quality monitoring units. The facts brought to light include the following:

- a. There was little difference in probe design for each package. For long-term deployment, reliability, stability, and maintainability results were unsatisfactory. For short-term deployment, both units would render satisfactory results if adequate attention were given to calibration procedures.
- b. The operational environment has a significant effect on data reliability and maintenance requirements. Even though the data were inconclusive, there were indications that turbidity, water temperature and currents affected the accuracy of the measurements.
- c. There exists a great disparity between the warm-up periods required by the water-quality packages in the laboratory and warm-up periods in the field. Warm-up periods in the fields are substantially longer, probably due to environmental and adverse temperature conditions. The importance of the warm-up period in acquiring accurate data cannot be overly emphasized, and the normal 90-sec transducer stabilization time of the WDT should be specified as a minimum requirement.
- d. Important deployment considerations must be given to each water-quality and WDT field installation.
- e. Both the Hydrolab and Martek units were compatible with the WDT.
- f. Accuracies as presented in the published specifications were not verified for any of the units.
- g. Calibration procedures were inadequately emphasized by manufacturers and it became evident that in order to obtain accurate data in the field good calibration techniques must be implemented. The calibration program used by WES was to calibrate the units in the laboratory and transport them to the test site, but as the data attests, the procedure proved to be inadequate.

Recommendations

30. The scope of the program discussed herein was limited to evaluation of a selection of existing sensor packages. The conduct of the experiment was affected by the need to check out the WDT and water-quality unit compatibility at the same time as the water-quality units were being evaluated. It is recommended that a comprehensive program be initiated to include the following:

- a. Conduct a state-of-the-art review of sensor design technology, including a review of the latest work being done in environmental, medical, and space sciences (e.g., bioprobe of Mars).
- b. Evaluate individual sensors and/or sensor packages available from other manufacturers under a variety of environmental conditions encompassing the total range of conditions that may be related to LMVD's overall mission. Deploy sensor packages by different manufacturers in the same environment simultaneously, at least in pairs, and use a baseline for comparing them.
- c. Develop calibration techniques for each parameter under various environmental conditions.
- d. Examine the feasibility of increasing the number of parameters that may be monitored.
- e. Develop and evaluate sensors compatible with LMVD monitoring requirements.
- f. Design and develop digital circuitry compatible with the digital input of the WDT to increase the accuracy of analog measurements.
- g. Deploy and evaluate the performance of water-quality sensors under various field environments in the LMVD.

Table 1
 Electrical and Physical Characteristics of Water-Quality Monitoring Units Evaluated

	Martek V	Oceandata 101B	HydroLab 6D12	InterOcean 513D
Parameters				
Temperature, °C	-5°/45°	-5°/40°	-5°/45°	-5°/45°
Condition, μmhos	0/1000	0/30	0/1000	0/65
Dissolved oxygen, ppm	0/20	0/30	0/20	0/20
pH	0/12	0/14	2/12	2/14
Unit output				
Sonde*	Millivolts, DC	Millivolts, DC	Millivolts, DC	Volts, DC
Surface	0/1 V DC	Scaled	0/5 V DC	-----
Power input	+18/36 V DC	+12 V DC	+6 V DC	+12 V DC
Warm-Up time,** min	1	5	1	1
Unit weight, lb				
Sonde	3	14	15	20
Surface	15	25	12	-----
Unit size				
Sonde	2-1/2 in. diam x 11 in.	8 in. diam x 24 in.	6-3/4 in. diam x 21 in.	5-1/2 in. diam x 29 in.
Surface	6 in. x 9-1/4 in. x 11 in.	12 in. x 11 in. x 9 in.	14 in. x 10 in. x 9 in.	-----

* Underwater unit.

** Water data transmitter energizes instrumentation 90 sec prior to transmission.

Table 2
Measurement Range, Calibration Method, and Accuracies of Parameters Evaluated

<u>Parameter</u>	<u>pH</u>	<u>DO</u>	<u>Conductivity</u>	<u>Temperature</u>
<u>Measuring technique</u>	Polarographic	Membrane Amperometric	Conductometric	Resistance
<u>Measuring range</u>	Varied	0 to 20 ppm	Varied	5°/45°C
<u>Calibration method</u>	pH-buffer solutions	Winkler method	Standard solution	Ice point
<u>Accuracy, percent</u>	1	0.5	5	0.1
<u>System response</u>	<10 sec	<1 min	<10 sec	<10 sec
<u>Possible interference</u>	Highly sensitive to contamination from silt and algae			

Table 3
Laboratory Calibration Data

	<u>L_A</u>	<u>Martek</u>	<u>Hydrolab</u>	<u>L_B</u>
Temperature, °C	17.1	17.55	17.55	17.5
DO, ppm	8.9	8.85	8.85	8.85
pH	7.95	7.85	7.85	7.85
Conductivity, $\frac{\mu\text{mhos}}{\text{cm}}$	188.0	187.0	187.0	188.0

Note: L_A and L_B represent analytical data.

Table 4

Data Gathered During Low River Stage

	DO ₁ ppm			pH			Conductivity µmhos/cm			Temperature °C		
	H	M	L	H	M	L	H	M	L	H	M	L
10/20 PM	9.2	9.35	9.4	7.8	7.57	7.6	425	430	430	17	17	17
10/21 AM	9.6	9.34	9.03	8.9	5.88	7.45	450	463	450	16	16.4	16.5
PM	9.7	9.40	9.10	8.85	5.50	7.2	450	450	450	16	16.45	16.25
10/22 AM	9.6	7.01	8.8	6.65	4.56	7.65	430	432	435	16	16	16
PM	9.55	7.3	8.88	6.70	4.65	7.45	430	432	435	16	16.3	16
10/23 AM	9.6	17.8	9.0	9.0	5.42	7.8	415	422	420	15.9	16.1	16
PM	8.8	19.0	9.0	9.0	5.32	7.8	422	415	420	16.1	15.9	16
10/24 AM	9.8	11.65	8.9	8.8	5.35	7.35	415	420	420	15.8	16.0	16.0
PM	9.6	11.98	8.85	8.75	5.0	7.25	410	416	415	15.8	16.0	16.0
10/25 AM	9.8	10.8	8.9	8.7	5.45	7.45	405	415	412	15.8	15.9	16.0
PM	9.4	10.6	8.93	8.9	5.28	7.35	405	414	414	15.8	15.9	16.0
10/26 AM	9.8	12.8	8.7	8.9	5.2	7.35	400	390	395	15.3	15.4	15.5
PM	9.7	11.3	8.55	8.95	5.15	7.38	390	395	400	15.3	15.4	15.5

Note: H = Hydrolab, M = Martek, L = Laboratory.

Table 5

Data Gathered During Rising River Stage

	DO, ppm			pH			Conductivity µmhos/cm			Temperature °C		
	H	M	L	H	M	L	H	M	L	H	M	L
11/3 PM	9.8	12.5	9.95	8.7	7.62	7.4	360	254	260	13.0	12.4	13.0
11/4 AM	*	*	9.9	*	*	7.5	*	*	285	*	*	13.0
11/4 PM	*	*	9.95	*	*	7.5	*	*	285	*	*	13.0
11/5 AM	9.9	13.4	9.8	9.0	7.58	7.45	315	228	290	12.0	11.7	12.8
11/5 PM	9.9	9.24	10.0	9.5	7.70	7.29	330	242	280	12.8	12.4	12.9
11/6 PM	9.8	8.01	9.65	9.2	7.88	7.65	270	239	260	12.9	12.2	12.4
11/7 PM	9.9	9.24	9.75	9.5	7.7	7.6	330	242	280	12.8	12.4	12.6

Note: H = Hydrolab, M = Martek, L = Laboratory.

* Operator error, data unavailable.

In accordance with letter from DAEN-RDC, DAEN-ASI dated 22 July 1977, Subject: Facsimile Catalog Cards for Laboratory Technical Publications, a facsimile catalog card in Library of Congress MARC format is reproduced below.

Ford, Alfred W

Investigation of remote water-quality monitoring systems for use with GOES or ERTS water data transmitter / by Alfred W. Ford. Vicksburg, Miss. : U. S. Waterways Experiment Station ; Springfield, Va. : available from National Technical Information Service, 1977.

41, [5] p. : ill. ; 27 cm. (Technical report - U. S. Army Engineer Waterways Experiment Station ; Y-77-5)

Prepared for River and Reservoir Control Center, U. S. Army Engineer Division, Lower Mississippi Valley, Vicksburg, Miss.

1. Equipment. 2. Monitoring. 3. Remote sensing. 4. Transmitters. 5. Water quality. I. United States. Army. Corps of Engineers. Lower Mississippi Valley Division. II. Series: United States. Waterways Experiment Station, Vicksburg, Miss. Technical report ; Y-77-5.
TA7.W34 no.Y-77-5