

AD-A047 850

NAVAL WEAPONS CENTER CHINA LAKE CALIF
TEMPERATURE DEPENDENCE OF THE DIELECTRIC CONSTANT OF QUARTZ POL--ETC(U)
DEC 77 J W BATTLES, K D KUEHN

F/G 11/2

UNCLASSIFIED

NWC-TP-5983

NL

| OF |
AD
A047850



END
DATE
FILMED
1 -78
DDC

AD A 0 4 7 8 5 0

(13) sc

NWC TP 5983

Temperature Dependence of the Dielectric Constant of Quartz Polyimide

by
James W. Battles
Research Department
and
Karl D. Kuehn
Weapons Department

DECEMBER 1977



Approved for public release; distribution unlimited.

AD No. _____
DDC FILE COPY

Naval Weapons Center

CHINA LAKE, CALIFORNIA 93555



Naval Weapons Center

AN ACTIVITY OF THE NAVAL MATERIAL COMMAND

FOREWORD

This report is the result of a radome measurement program performed for the Weapons Development Department, Code 39. This is a final report and represents work performed during March and April 1977. The funding was supplied under AIRTASK Project No. A03P-03P2/008C/7W055/-001.

This report has been reviewed for technical accuracy by Mr. D. J. White.

Approved by
E. B. ROYCE, *Head*
Research Department
14 September 1977

Under authority of
W. L. HARRIS, JR.
RAdm., U.S. Navy
Commander

Released for publication by
R. M. HILLYER
Technical Director (Acting)

NWC Technical Publication 5983

Published by Technical Information Department
Collation Cover, 4 leaves
First printing 80 unnumbered copies

INITIAL DISTRIBUTION

- 5 Naval Air Systems Command
 - AIR-31B, J. Willis (1)
 - AIR-360, R. Thyberg (1)
 - AIR-360E, V. A. Tarulis (1)
 - AIR-954 (2)
- 1 Naval Electronics Systems Command (PME-121)
- 2 Naval Sea Systems Command (SEA-09G32)
- 1 Naval Air Development Center, Warminster (AFTD Radar Division, M. Foral)
- 2 Naval Ocean Systems Center, San Diego
 - Code 2330
 - J. H. Provencher (1)
 - D. Rubin (1)
- 1 Naval Research Laboratory (Radar Division, Dr. Skolnik)
- 1 Office of Naval Research Branch Office, Pasadena (Dr. R. G. Brandt)
- 1 Army Missile Research & Development Command, Redstone Arsenal (AMSMI-RER, Hammond Green)
- 1 Army Ballistics Research Laboratories, Aberdeen Proving Ground (AMXBR-CA, Ken Richer)
- 2 Air Force Armament Laboratory, Eglin Air Force Base
 - DLMT
 - Charles Brown (1)
 - Dr. D. B. Ebeogla (1)
- 1 Air Force Cambridge Research Laboratory, Laurence G. Hanscom Field (Dr. E. E. Altshuler)
- 1 Defense Advanced Research Projects Agency, Arlington (Dr. James Tegnalia)
- 12 Defense Documentation Center
 - 1 Vought Corporation, Systems Division, Dallas, TX (Pat Fremming)

UNCLASSIFIED

SECURITY CLASSIFICATION OF THIS PAGE (When Data Entered)

REPORT DOCUMENTATION PAGE		READ INSTRUCTIONS BEFORE COMPLETING FORM
1. REPORT NUMBER NWC-TP-5983 ✓	2. GOVT ACCESSION NO.	3. RECIPIENT'S CATALOG NUMBER
4. TITLE (and Subtitle) TEMPERATURE DEPENDENCE OF THE DIELECTRIC CONSTANT OF QUARTZ POLYIMIDE.		5. TYPE OF REPORT & PERIOD COVERED Final rept.
7. AUTHOR(s) James W./Battles Karl D./Kuehn		6. PERFORMING ORG. REPORT NUMBER
8. PERFORMING ORGANIZATION NAME AND ADDRESS Naval Weapons Center China Lake, CA 93555 ✓		8. CONTRACT OR GRANT NUMBER(s)
11. CONTROLLING OFFICE NAME AND ADDRESS Naval Weapons Center China Lake, CA 93555	12. REPORT DATE Dec 1977	10. PROGRAM ELEMENT, PROJECT, TASK AREA & WORK UNIT NUMBERS AIRTASK Project No. A03P-03P2/008C/7W055/-001
14. MONITORING AGENCY NAME & ADDRESS (if different from Controlling Office)	13. NUMBER OF PAGES 6	11. SECURITY CLASS. (of this report) UNCLASSIFIED
		15a. DECLASSIFICATION/DOWNGRADING SCHEDULE
16. DISTRIBUTION STATEMENT (of this Report) Approved for public release; distribution unlimited.		
17. DISTRIBUTION STATEMENT (of the abstract entered in Block 20, if different from Report)		
18. SUPPLEMENTARY NOTES		
19. KEY WORDS (Continue on reverse side if necessary and identify by block number) Millimeter Wave Dielectric Constant Temperature Composite		
20. ABSTRACT (Continue on reverse side if necessary and identify by block number) See back of form.		

DD FORM 1 JAN 73 1473

EDITION OF 1 NOV 65 IS OBSOLETE
S/N 0102-014-6601

UNCLASSIFIED

SECURITY CLASSIFICATION OF THIS PAGE (When Data Entered)

403019

net

UNCLASSIFIED

SECURITY CLASSIFICATION OF THIS PAGE(When Data Entered)

(U) *Temperature Dependence of the Dielectric Constant of Quartz Polymide*, by James W. Battles and Karl D. Kuehn. China Lake, Calif., Naval Weapons Center, December 1977. 6 pp. (NWC TP 5983, publication UNCLASSIFIED.)

(U) A doppler generator was used to measure the complex dielectric constant of quartz polymide at 35 GHz from room temperature to 840°F (450°C).



UNCLASSIFIED

SECURITY CLASSIFICATION OF THIS PAGE(When Data Entered)

INTRODUCTION

A quartz polyimide sample was provided the Naval Weapons Center by the Vaught Corporation for the purpose of measuring the temperature dependence of its dielectric constant at 35 GHz. The method used to measure the dielectric constant is new and will be briefly described.

EXPERIMENTAL METHOD

An object moving with a known velocity in a waveguide creates a unique doppler frequency for each electromagnetic wavelength in the normal operating band of the waveguide. The measured doppler frequency can be used to calculate the carrier frequency. When each half of the waveguide is filled with a dielectric leaving a narrow slit for the post, then the doppler frequency change caused by the dielectric can be used to calculate the dielectric constant.

Figure 1 is a drawing of a doppler generator that will work as described above. Since the waveguide circle is a known diameter and the rotor and post rotate at a known frequency, the real part of the dielectric constant, K_e , will be given by

$$K_e = [(\frac{f_c}{f_\tau})^2 + (\frac{f_d}{f_\tau})^2 (C/4\pi r f_o)^2] A \quad , \quad (1)$$

where

f_c = waveguide cutoff frequency

f_τ = carrier frequency

f_d = doppler frequency

C = velocity of light

r = radius of waveguide circle

f_o = rotor rotational frequency

$A = \frac{\text{cross sectional area of waveguide}}{\text{cross sectional area of dielectric}}$

ACCESSION for	
NTIS	White Section <input checked="" type="checkbox"/>
DDC	Buff Section <input type="checkbox"/>
UNANNOUNCED	<input type="checkbox"/>
DISTRIBUTION _____	
BY _____	
DISTRIBUTION/AVAILABILITY CODES	
	SPECIAL
A	

NWC TP 5983

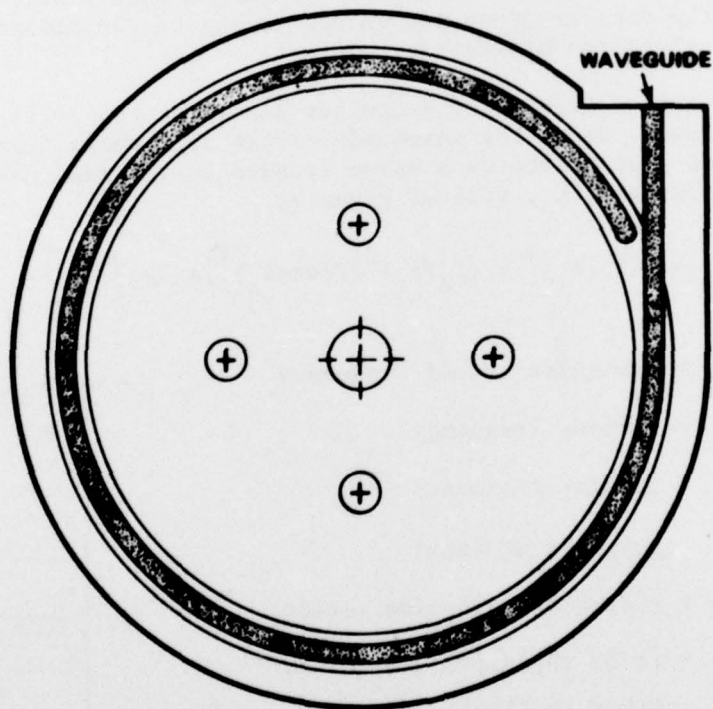
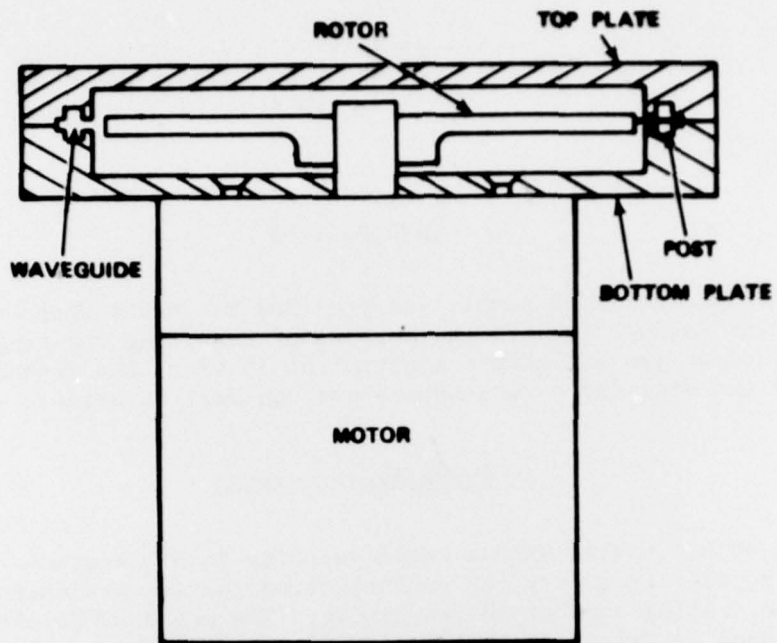

FIGURE 1. Basic Design of a Waveguide Doppler Generator.

The loss tangent of the dielectric can be determined from the amplitudes of the doppler signal for two or more different path lengths in the dielectric. Figure 2 shows two positions of the post as it is being rotated in the dielectric filled doppler generator. The doppler signal from the post in position A has required the carrier to traverse the dielectric length in both directions. Thus, if we measure the amplitudes of the signal envelope, the post positions A and B, we can calculate the loss tangent from

$$\tan \delta = - \frac{\ln R}{2\omega \ell \sqrt{\epsilon' \mu_0}} \quad (2)$$

where

$$R = \frac{\text{signal amplitude at A}}{\text{signal amplitude at B}}$$

ℓ = arc length from point A to point B through the dielectric

$$\omega = 2\pi f$$

$$\epsilon' = K_e \epsilon_0; \quad \epsilon_0 = 8.854 \times 10^{-12}$$

$$\mu_0 = 4\pi \times 10^{-12}$$

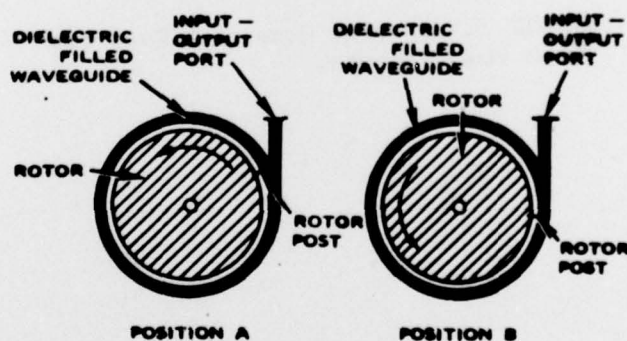

FIGURE 2. Position A Indicates the Post at the Farthest Point in the Dielectric Waveguide from the Waveguide Port; Position B Indicates the Post Near the Waveguide Port. The signal envelope amplitudes at positions A and B can be used to calculate the loss tangent.

A doppler generator was designed and built that would keep the rotor bearing and the motor cool during the temperature cycle (see

Figure 3). A cooling gas (98% N; 2% H) was used to keep the bearings cool and was vented out through the waveguide. The flow rate was 3 ml/sec. The 2% H was used to keep the copper waveguide walls clean of oxides. Figure 4 is a schematic diagram of the test setup.

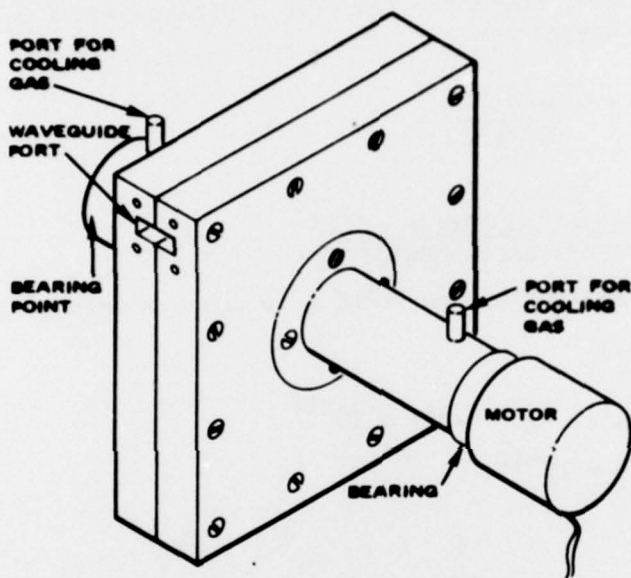

FIGURE 3. Doppler Generator Used for These Measurements.

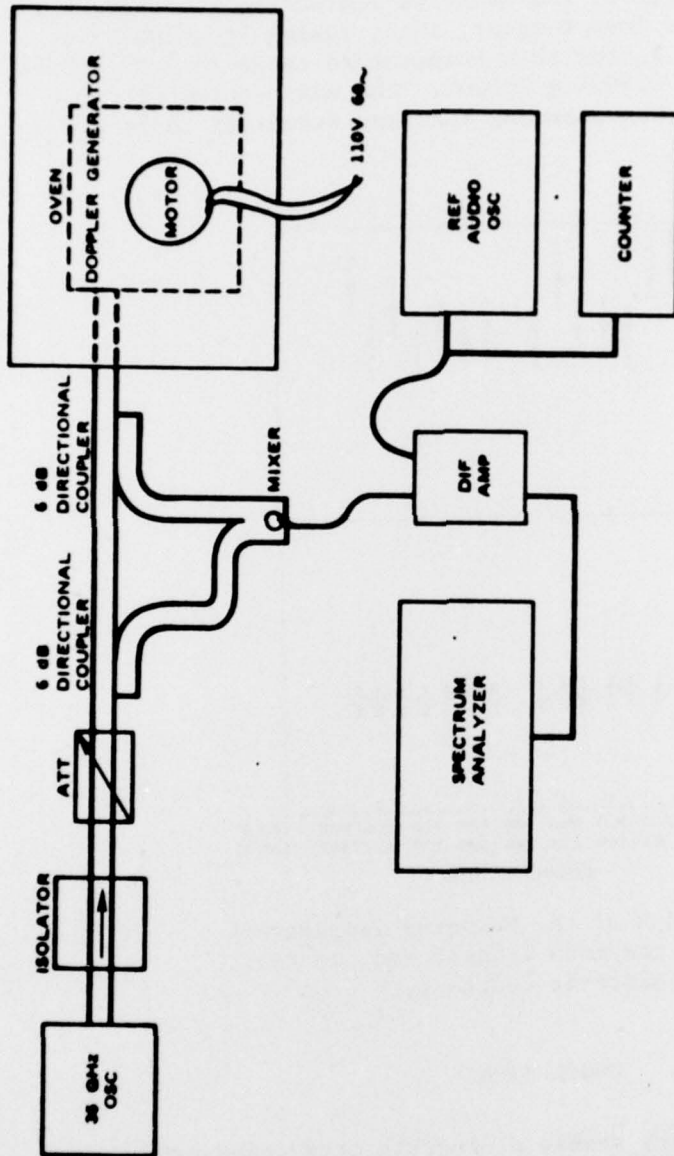

FIGURE 4. Schematic Diagram of the Test Setup.

RESULTS

Data were taken over the temperature range 70 to 840°F (21 to 449°C). Figure 5 is a graph of the measured dielectric constant, K_e , (using Equation 1) and the loss tangent, $\tan\delta$, (using Equation 2) as a function of temperature. K_e for this temperature range is 3.00 ± 0.005 . $\tan\delta$ is best described by 0.0034 ± 0.0005 . The main source of error during these measurements was assuming the line frequency to be a constant 60 Hz.

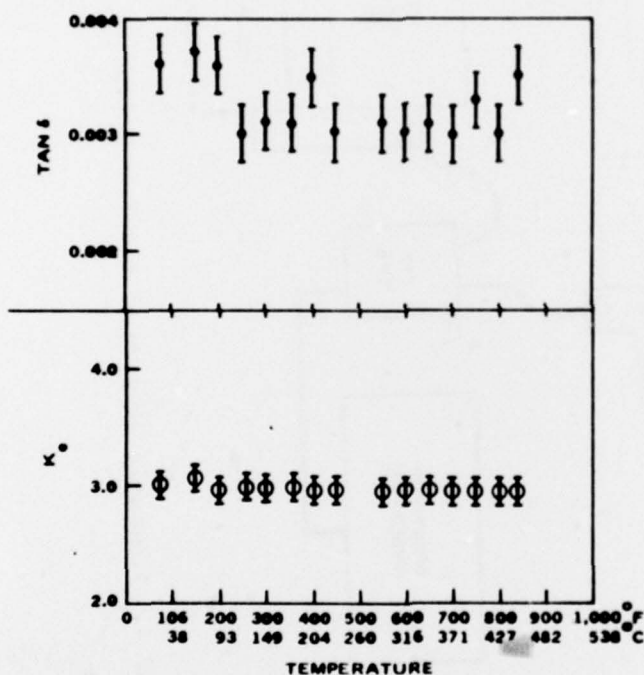

FIGURE 5. Graph of the Measured Temperature Dependence of the Loss Tangent and the Real Part of the Dielectric Constant.

CONCLUSIONS

Quartz polyimide has very stable dielectric properties over this temperature range. It should be noted that no oxygen was present near the quartz polyimide during these tests. Thus, it may be necessary to heat the quartz polyimide in air for a fixed period of time at each temperature and then cool the sample to room temperature for the dielectric constant measurements. In this way, the copper waveguide would not be heated and there would be no waveguide oxidation problem.