

AD-A047 853

ARMY ELECTRONICS COMMAND FORT MONMOUTH N J
FIBER-OPTICS DOSIMETER FOR CIVIL DEFENSE.(U)
NOV 77 S KRONENBERG, C SIEBENTRITT
ECOM-4545

F/G 6/18

UNCLASSIFIED

NL

| OF |
ADA047853



END
DATE
FILMED
1 - 78
DDC



12

Research and Development Technical Report
ECOM-4545

AD A 047853

FIBER-OPTICS DOSIMETER FOR CIVIL DEFENSE

Stanley Kronenberg
Electronics Technology & Devices Laboratory

Carl Siebentritt
Defense Civil Preparedness Agency

November 1977

DDC
RECEIVED
DEC 27 1977

97

DISTRIBUTION STATEMENT
Approved for public release;
distribution unlimited.

AD NO.

DDC FILE COPY

ECOM

US ARMY ELECTRONICS COMMAND FORT MONMOUTH, NEW JERSEY 07703

NOTICES

Disclaimers

The findings in this report are not to be construed as an official Department of the Army position, unless so designated by other authorized documents.

The citation of trade names and names of manufacturers in this report is not to be construed as official Government indorsement or approval of commercial products or services referenced herein.

Disposition

Destroy this report when it is no longer needed. Do not return it to the originator.

UNCLASSIFIED

SECURITY CLASSIFICATION OF THIS PAGE (When Data Entered)

REPORT DOCUMENTATION PAGE		READ INSTRUCTIONS BEFORE COMPLETING FORM	
1. REPORT NUMBER 14 ECOM-4545	2. GOVT ACCESSION NO.	3. RECIPIENT'S CATALOG NUMBER 9 Research and development	
4. TITLE (and Subtitle) 6 FIBER-OPTICS DOSIMETER FOR CIVIL DEFENSE		5. TYPE OF REPORT & PERIOD COVERED Technical rept.	
7. AUTHOR(S) 10 Stanley Kronenberg Carl Siebentritt - Defense Civil Preparedness Agency		8. CONTRACT OR GRANT NUMBER(s)	
9. PERFORMING ORGANIZATION NAME AND ADDRESS Electronic Materials Research Technical Area US Army Electronics Technology & Devices Lab Fort Monmouth, NJ 07703 DRSEL-TL-EN		10. PROGRAM ELEMENT, PROJECT, TASK AREA & WORK UNIT NUMBERS 697417.W48.60.06.04 (DCPA)	
11. CONTROLLING OFFICE NAME AND ADDRESS US Army Electronics Command DRSEL-TL-EN Fort Monmouth, NJ 07703		11 12. REPORT DATE November 1977	
14. MONITORING AGENCY NAME & ADDRESS (if different from Controlling Office) 12 14p.		13. NUMBER OF PAGES 7	
		15. SECURITY CLASS. (of this report) UNCLASSIFIED	
		15a. DECLASSIFICATION/DOWNGRADING SCHEDULE	
16. DISTRIBUTION STATEMENT (of this Report) Approved for public release; distribution unlimited.			
17. DISTRIBUTION STATEMENT (of the abstract entered in Block 20, if different from Report)			
18. SUPPLEMENTARY NOTES			
19. KEY WORDS (Continue on reverse side if necessary and identify by block number) Dosimeter Fiber optics Radiation effects in fiber optics Glass dosimetry			
20. ABSTRACT (Continue on reverse side if necessary and identify by block number) The Defense Civil Preparedness Agency (DCPA) has a requirement for a shelter dosimeter, a standby instrument for monitoring gamma ray doses in the event of an atomic war or a nuclear disaster. Its most important requirement is dependability without reliance on external components such as power sources. Radiation-induced darkening of optical fiber has been utilized to construct such a dosimeter in which the dose dependent darkening of glass fibers is read visually by means of a dose-calibrated gray scale.			

D D C
DECLASSIFIED
DEC 27 1977
F

037 620

JB

CONTENTS

	Page
INTRODUCTION	1
BASIC PRINCIPLE OF OPERATION	1
CONSTRUCTION OF PROTOTYPE FIBER-OPTICS DOSIMETERS	2
CALIBRATION AND PERFORMANCE	5
PERSISTENCE OF READING	5
ENERGY DEPENDENCE	7
ALTERNATE APPLICATION IN A FIBER-OPTICS PERSONNEL DOSIMETER	7

FIGURES

1. Principle of operation and construction of prototypes of the fiber-optics shelter dosimeter	3
2. Ratio of transparency after irradiation with 1000 rad (tissue) ⁶⁰ Co gamma rays to transparency before irradiation as a function of wavelength	4
3. Calibration of the fiber-optics dosimeter	6

ACCESSION FOR	
NTIS	<input checked="" type="checkbox"/>
DDC	<input type="checkbox"/>
UNANNOUNCED	<input type="checkbox"/>
JUSTIFIED	<input type="checkbox"/>
BY	
DISTRIBUTION/AVAILABILITY NOTES	
A	

FIBER-OPTICS DOSIMETER FOR CIVIL DEFENSE

INTRODUCTION

Radiological instruments are required for emergency operations directed at the survival of citizens in the event of a nuclear attack. To this end, the Defense Civil Preparedness Agency has a requirement for gamma dosimeters for monitoring in fallout shelters. Requirements for such dosimeters differ significantly from other types of dosimeters such as those for field or laboratory use.

The most important requirement of a shelter dosimeter is its reliability. It should be capable of storage in a civil defense shelter or in secure repositories for many years without maintenance or recalibration and be instantly available for use in case of need. Other pertinent requirements are: 1) Its range, dictated by its application in monitoring exposure of personnel during a nuclear war or nuclear disaster, should provide readings from about 20 rad (tissue) up to the lethal dose of about 1000 rad (tissue). 2) It must be self-contained, requiring neither separate readout device nor power source. 3) It must be easy to operate and interpret. 4) It must be a low-cost instrument capable of being mass produced.

For strategic nuclear weapons, which apply in the case of Civil Defense, the range of total destruction is larger than the range of fast neutrons; therefore only the response of the dosimeter to gamma rays produced by radioactive isotopes (e.g., from fallout) is of interest. The utilization of the radiation-induced darkening of glasses or plastics is an approach which can satisfy all these requirements.

BASIC PRINCIPLE OF OPERATION

Ionizing radiation such as gamma rays darkens glass by producing absorption centers. The value of the resulting absorption coefficient (μ) depends on the density of these absorption centers as well as the type of glass and the wavelength (λ) of the light transmitted. The transparency (T) can be expressed in general as

$$T = \exp [-\mu(D, \lambda)x]$$

where x is the thickness of the glass and D is the delivered dose. In most cases the density of centers is linear with dose; therefore the absorption coefficient can be written

$$\mu(D, \lambda) = D k(\lambda)$$

where $k(\lambda)$ depends only on the type of glass.

To induce significant darkening in small thicknesses of glass, large doses are required. Various glass dosimeters are thus commonly used for measurements of high gamma doses (in the range of 10^3 - 10^7 rads).¹ To utilize the effect for personnel dosimetry, the sensitivity must be raised by drastically increasing the thickness of the glass. This is accomplished in practice

1. Frank H. Attix and William C. Roesch, Radiation Dosimetry (Academic Press, New York, 1966), pp. 248-257.

by the use of optical fibers. Figure 1 illustrates both the basic principle of such a dosimeter and the finished working prototype. Two pieces of optical fiber, one short and the other much longer, are arranged so that the same light intensity is incident on one end of each. Exposure to gamma rays darkens both pieces, the longer one much more severely. After irradiation, the light intensities emerging from the opposite ends are compared visually and equalized by attenuating the light incident on the short piece by means of a transmission gray scale. The dose can then be read out by means of a calibrated dose scale attached to the gray scale.

CONSTRUCTION OF PROTOTYPE FIBER-OPTICS DOSIMETERS

We constructed 30 identical working models of such fiber-optics dosimeters to test their operational parameters using Corning 5010 fiber (lead silicate with borosilicate cladding, numerical aperture - 0.67). It is a "high loss" fiber with the normal attenuation of 1 dB m^{-1} for red light. Three hundred and eighty individual 0.04-mm diameter fibers are bundled in plastic tubing of approximately 2 mm outside diameter. This type of fiber was chosen because its radiation-induced darkening was more permanent than that of other commercially available cables which were tried. It also exhibited a strong response to radiation, permitting use of relatively short lengths. The wavelength dependence and permanence of the radiation-induced darkening for this fiber-optics cable is shown in Figure 2. The darkening effect was strongest in the blue region and most permanent there. Blue was therefore chosen as the region of operation. The length of the long piece of fiber was chosen to be 160 cm. One thousand rad (tissue) of ^{60}Co gamma rays changed the transparency of that length in the blue region by a factor of 400 (corresponding to a change in density of 1.6). This was found to be within a convenient range of operation.

The readout of the instrument depends on making two areas of light appear equal in intensity to the viewer's eye; thus the psychophysical effects in human vision had to be considered. It is difficult to compare accurately the intensities of two areas of light of different color. The fiber exposed to radiation appears red brown. Placing a filter of blue glass at the light input of the instrument eliminated this problem. The blue filter strongly reduces the incident light, requiring a high input intensity such as strong daylight. This can be corrected in future models by using instead of a gray scale a scale resembling in color the radiation affected fiber and leaving the filter out entirely.

Another psychophysical effect to be considered is the difficulty in deciding visually if two light spots are equal when they have a borderline between them. The most accurate reading can be taken if at the setting for equal brightness the light spots melt into a single light spot. To obtain this the fibers of the long and of the short bundles are compressed into a single bundle at the output end and glued together with epoxy. The reading is taken by looking through the magnifying lens at the output and rotating the gray scale in front of the short fiber until the circular blue spot which is subdivided into two irregular regions of darker and lighter shades becomes closest to a circle of uniform blue light. Nonuniformity in the appearance of the dots formed by individual fibers caused some difficulty in reading out the dose. This can be alleviated by more carefully polishing the cutoff ends of the fibers.

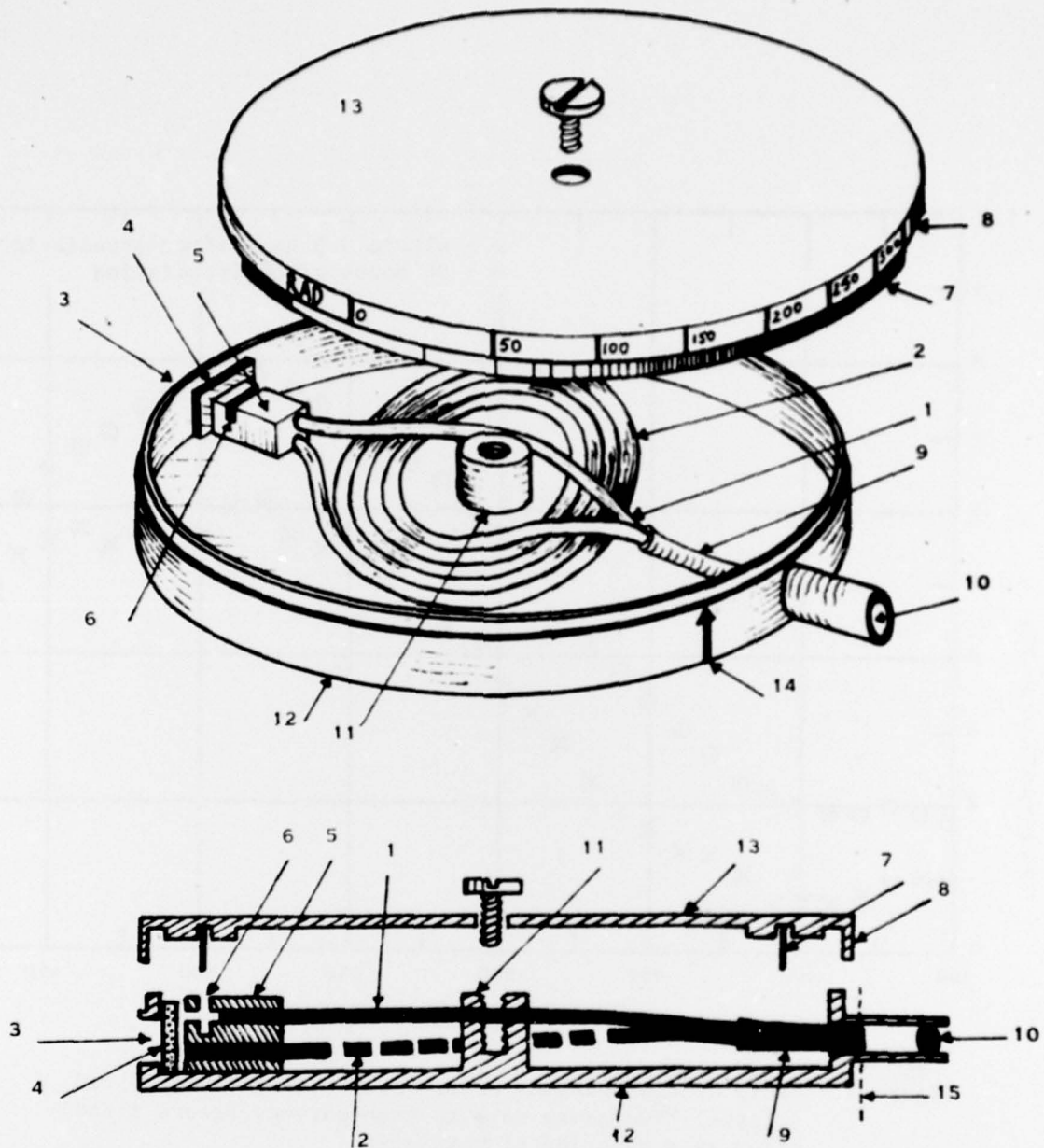

Figure 1. Principle of operation and construction of prototypes of the fiber-optics shelter dosimeter

- | | |
|--|---|
| 1 - Short fiber bundle | 9 - Joined fiber bundles |
| 2 - Coil of long fiber bundle | 10 - Readout lens (acrylic plastic) |
| 3 - Light input window | 11 - Pivot block for top cover |
| 4 - Blue filter (glass) | 12 - Body (phenolic plastic) |
| 5 - Mounting block for fibers (phenolic plastic) | 13 - Rotating top cover (acrylic plastic) |
| 6 - Slot for the gray scale | 14 - Readout marker |
| 7 - Gray scale (photographic film) | 15 - Focal plane |
| 8 - Readout scale | |

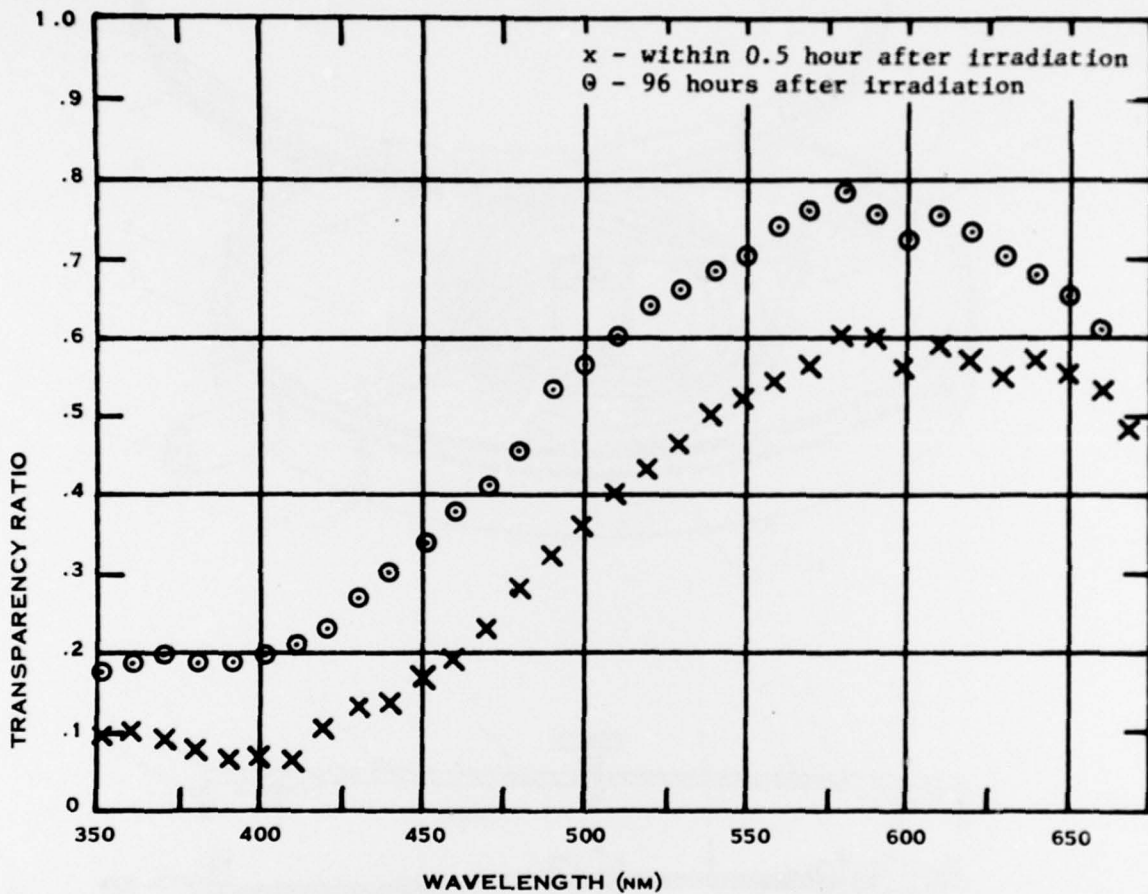

Figure 2. Ratio of transparency after irradiation with 1000 rad (tissue) ^{60}Co gamma rays to transparency before irradiation as a function of wavelength.

The instrument is contained in a flat cylindrical box 10 cm in diameter and 1.5 cm high (see Figure 1). Both the gray scale and the readout scale are mounted on one edge of the cover, which can be rotated relative to a readout marker on the body of the instrument.

CALIBRATION AND PERFORMANCE

Two of the instruments were sacrificed to obtain scale calibration for the remaining ones. They were exposed to ^{60}Co gamma rays in increments of 50 rads and the dose was plotted against the average of two independent visual readings of the corresponding position on the gray scale (Figure 3). The readings are surprisingly reproducible considering the crudeness of the device and line up closely with the best fit curve. The scale obtained in this manner was inscribed on the periphery of the rotatable covers of the remaining instruments.

The following operating instructions were attached to the dosimeter:

NUCLEAR RADIATION FIBER-OPTICS DOSIMETER

OPERATING INSTRUCTIONS

When the recessed window is aimed toward a bright light, an irregular pattern of blue dots will be visible in the viewer opposite. While looking through the viewer, rotate the black disk until the changing intensity of half the dots best matches the fixed intensity of the other half. The accumulated dose, in rads (tissue), can then be read directly from the position of the pointer on the scale on the edge of the disk. Take a total of 3 readings and average the results.

PERSISTENCE OF READING

In all types of glass the radiation-induced darkening fades with time. The extent of fading depends on the type of glass, the wavelength of the transmitted light, and the ambient temperature. This introduces errors in readout which make many types of glass useless for dosimetry. In the fibers used here the rate of room temperature fading is considerable within the first several hours but then slows to a very low value. Successive readings after delays of four months have changed by only about 10%. Exposure to high ambient temperatures accelerates the fading significantly and temperatures of approximately 60°C reduce the reading by about 50% within a day.

We have found a way to reduce the fading of the lead silicate fiber. Exposure to a dose of 2×10^4 rad (tissue) darkens the fiber very strongly. This darkening can be partially annealed by keeping the fiber for 12 hours at a temperature of 200°C . Subsequent exposures produce darkening which fades at a slower rate than in an untreated fiber. We did not use this treatment for dosimeters described here because the normal fading did not seriously affect the operation of a shelter dosimeter, whose accuracy requirements are not very stringent. Other types of glass such as borosilicates show a higher persistence even at elevated temperatures and are being considered for this application.

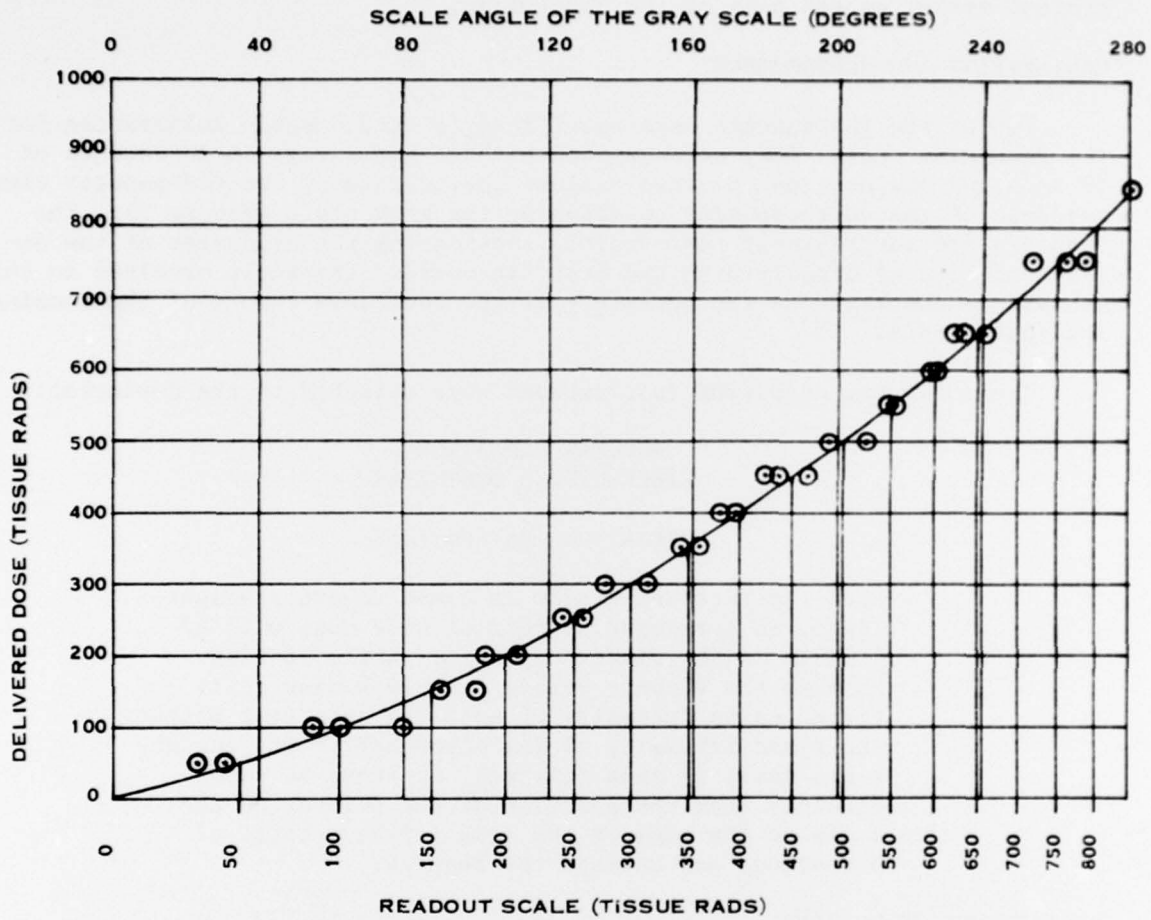

Figure 3. Calibration of the fiber-optics dosimeter. Dose of ^{60}Co gamma rays (delivered in 50 rad increments) versus scale angle of the gray scale. The readout scale at bottom was constructed by projecting the dose at left from the best fit curve.

The best solution of the fading problem appears to be the use of single plastic fibers approximately 1 mm in diameter, which change color permanently when exposed to radiation. Such plastics are routinely used in dosimetry involving large doses such as in food sterilization.² The long and short plastic fibers would be fused under heat at the viewing end. Care should be taken to fuse only a length shorter than the fiber diameter to avoid fusion of the two images.

Pure silica fiber or germanium doped silica low-loss fibers such as those used for fiber-optics communication purposes show a fast fading. This and their low sensitivity to radiation-induced darkening exclude the use of these fibers for dosimetry.

ENERGY DEPENDENCE

The diameter of the fiber is smaller than the average range of electrons produced by the gamma rays, so that the electron equilibrium in the fiber is predominantly defined by the plastic body of the instrument, whose response is very close to tissue. Therefore, according to the Brag Gray relation the quantum energy response of this dosimeter is, in practice, tissue equivalent within the accuracy limitations of the readout.

ALTERNATE APPLICATION IN A FIBER-OPTICS PERSONNEL DOSIMETER

Optical fibers also can be used to construct other kinds of personnel dosimeters than shelter dosimeters. An example is a very simple battery-operated tissue-equivalent dosimeter based on the transmission of light from a light emitting diode(LED) through a single fiber. Closing a switch activates the LED as well as a solid-state light detector whose output is displayed on a scale calibrated in rads. A 0.1-mm diameter borosilicate fiber can be utilized in this dosimeter for readings in tissue rads provided that the body of the dosimeter is constructed of tissue equivalent plastic. Such a dosimeter would also be sensitive to fast neutrons. The diameter of the fiber being less than the range of average energy recoil protons, the neutron dose received is close to the equilibrium dose of the hydrogenous bulk material. In practice, such a dosimeter could be built with a removable fiber unit which either could be replaced with a fresh one after exposure or re-activated by exposure to heat.

2. W.L. McLaughlin, "Solid Phase Chemical Dosimeters, Sterilization by Ionizing Radiation," Proc. Conf., Vienna, 1974, edited by E.R.L. Goughran and A.J. Goudie, Multiscience Montreal, pp. 219-253.