

AD-A047 903

ROCKWELL INTERNATIONAL RICHARDSON TEX HYBRID MICROEL--ETC F/G 9/5  
A PRODUCTION ENGINEERING MEASURE FOR TWO L-BAND SOLID STATE MIC--ETC(U).  
MAY 77 L D BACHMAN

DAAB07-76-C-0026

NL

UNCLASSIFIED

1 of 1

ADA047903

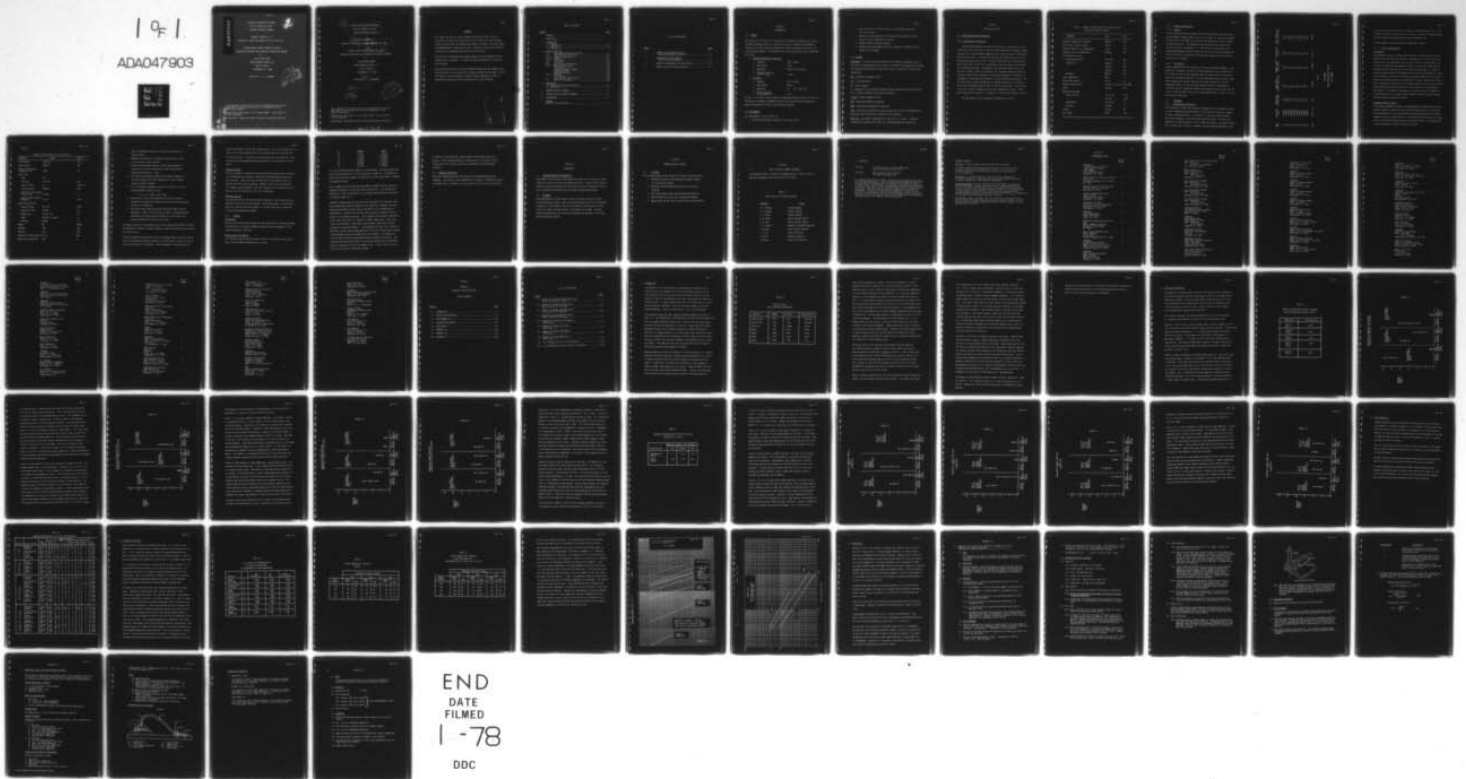

END  
DATE  
FILMED  
1 -78  
DDC

AD A 0 4 7 9 0 3

A PRODUCTION ENGINEERING MEASURE  
FOR TWO L-BAND SOLID STATE  
MICROWAVE FREQUENCY SOURCES



QUARTERLY REPORT NO. 4

COVERING THE PERIOD 28 FEBRUARY 1977 TO 31 MAY 1977

PREPARED UNDER CONTRACT DAAB07-76-C-0026

MANUFACTURING METHODS AND TECHNOLOGY ENGINEERING PROGRAM

BY

COLLINS RADIO GROUP

HYBRID MICROELECTRONICS DIV.

1200 N. ALMA RD.

RICHARDSON, TX 75080

WRITTEN BY: L. D. BACHMAN

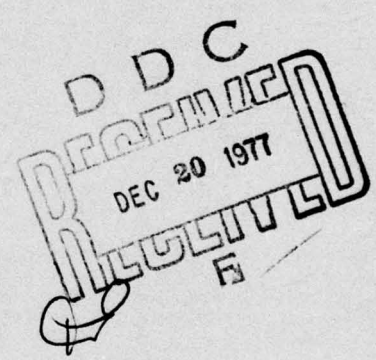

"The findings in this report are not to be construed as an official department of the army position unless so designated by other authorized documents."

"Destroy this report when it is no longer needed. Do not return it to the originator."

Unclassified: Approved for public release; distribution unlimited.

AD No. \_\_\_\_\_  
DDC FILE COPY

6

A PRODUCTION ENGINEERING MEASURE  
FOR TWO L-BAND SOLID STATE  
MICROWAVE FREQUENCY SOURCES

9

QUARTERLY REPORT NO. 4,  
COVERING THE PERIOD 28 FEBRUARY ~~1977~~ TO 31 MAY 1977,

15

PREPARED UNDER CONTRACT DAAB07-76-C-0026  
MANUFACTURING METHODS AND TECHNOLOGY ENGINEERING PROGRAM  
BY

COLLINS RADIO GROUP

HYBRID MICROELECTRONICS DIV.

1200 N. ALMA RD.

RICHARDSON, TX 75080

10

WRITTEN BY: L. D. BACHMAN

11

31 May 77

12

72p.

DDC  
REGISTERED  
DEC 20 1977  
F

"The findings in this report are not to be construed as an official  
department of the army position unless so designated by other  
authorized documents."

"Destroy this report when it is no longer needed. Do not return it  
to the originator."

Unclassified: Approved for public release; distribution unlimited.

409 963

LB

ABSTRACT

This report describes the specifications and approach, details the work completed in the design and fabrication of two L-band solid state frequency sources, and describes the progress made towards an eventual high rate production demonstration of these two circuits. These two circuits are a Modulator/Transmitter for Radiosonde applications and an FM Source.

The fourth set of Radiosonde engineering samples has been completed and performance data is available. All effort has been terminated on this portion of the program.

Work on the fourth set of FM Source engineering models has been stopped until complete analysis of the second order linearity problem has been made. Analytical analysis is being performed on several network topologies in order to determine the optimum oscillator configuration for best linearity.

ACCESSION for

NTIS	Write Section	<input checked="" type="checkbox"/>
DDC	Buff Section	<input type="checkbox"/>
UNANNOUNCED		<input type="checkbox"/>
JUSTIFICATION		

BY

DISTRIBUTION/AVAILABILITY CODES

Dist.	Avail.	Conf.	SP. CIAL
A			

## TABLE OF CONTENTS

<u>Section</u>	<u>Page</u>
ABSTRACT.....	i
FORM DD1473.....	
1 INTRODUCTION	
1.1 Purpose.....	1-1
1.2 Requirements.....	1-2
1.3 Glossary.....	1-2
2 NARRATIVE AND DATA	
2.1 Radiosonde Modulator/Transmitter.....	2-1
2.1.1 Description of the Device.....	2-1
2.1.2 Design Considerations.....	2-3
2.1.2.1 General.....	2-3
2.1.3 Test Results.....	2-3
2.2 FM Source.....	2-3
2.2.1 Description of the Device.....	2-3
2.2.2 Design Considerations.....	2-5
FM Linearity.....	2-5
Computer Synthesis Program.....	2-5
Snapstrate Design.....	2-8
Manufacturing Plan.....	2-8
2.2.3 Problems.....	2-8
FM Linearity.....	2-8
Shock and Spin Test Results.....	2-8
2.3 Materials Evaluation.....	2-10
3 CONCLUSIONS	
3.1 Radiosonde Modulator/Transmitter.....	3-1
3.2 FM Source.....	3-1
4 PROGRAMS FOR NEXT INTERVAL.....	4-1
5 IDENTIFICATION OF PROJECT PERSONNEL.....	5-1
6 DISTRIBUTION.....	6-1
7 APPENDIX	
Material Evaluation Report.....	7-1

LIST OF ILLUSTRATIONS

<u>Table</u>		<u>Page</u>
1	Summary of Requirements for the Radiosonde Modulator/Transmitter.....	2-2
2	Radiosonde Test Data Summary - Fourth Engineering Samples.....	2-4
3	Summary of Requirements for the FM Source.....	2-6
4	Identification of Project Personnel.....	5-7

SECTION 1  
INTRODUCTION

1.1 PURPOSE

The purpose of this contract is to establish the design and producibility of two microwave frequency sources, to improve the ability to produce the component or process and to compile data for production of these two sources on the basis of existing plant capacity. The characteristics of the devices are briefly described as follows:

A. Radiosonde Modulator/Transmitter

- |  |                      |
|--|----------------------|
| 1. Frequency                               | 1680 $\pm$ 20 MHz    |
| 2. Power Output                            | 65 mW                |
| 3. Modulation                              | 100% AM 0 to 1835 Hz |
| 4. Frequency Stability<br>(-70°C to +70°C) | $\pm$ 2 MHz          |

B. FM Source

- |   |                    |
|---|--------------------|
| 1. Frequency                              | 1375 $\pm$ 25 MHz  |
| 2. Power Output                           | 500 mW             |
| 3. Modulation                             | FM 0 to 1 MHz rate |
| 4. Tuning Linearity<br>(50 MHz Bandwidth) | $\pm$ 2%           |

Further, it is a goal of this program to investigate the application of thick film technology in microwave integrated circuits and to determine the processes and materials required for low cost, high volume production.

1.2 REQUIREMENTS

The requirements of this contract are:

1. Deliver 40 engineering samples of each circuit type.

2. Test and deliver, with test reports, 50 confirmatory samples of each circuit type.
3. Establish a pilot production line and fabricate 500 units of each type at a rate of 4000 units per month.
4. Prepare technical data and reports.
5. Determine the requirements and plans to support a production rate of 40,000 units per month.

### 1.3 GLOSSARY

Radiosonde - A miniature radio transmitter with instruments attached, which is carried by an unmanned balloon to a height of 105,000 ft and dropped by parachute, for broadcasting by means of precise tone signals, information on humidity and temperature.

MIC - Microwave integrated circuit

TBD - To be determined

RF - Radio frequency

Q - A measure of the relationship between stored energy and the rate of dissipation in certain elements, structures or materials

TC Bond - Thermo compression bond

PEM - Production engineering measures

MM&T - Manufacturing Methods and Technology

FRIT - Melted-glass composition, ground up and used in thick film compositions, that melts upon firing to give adhesion to the substrate.

MESH SIZE - The number of openings per lineal inch in a screen. A 200-mesh screen has 200 openings per lineal inch, 40,000 openings per square inch.

## SECTION 2

## NARRATIVE AND DATA

2.1 RADIOSONDE MODULATOR/TRANSMITTER2.1.1 Description of the Device

The Radiosonde Modulator/Transmitter consisting of a mechanically tuned L-Band thick film oscillator, a thick film hybrid modulator, a negative voltage regulator and a discone antenna comprises 90% of the electronics of Atmospheric Meteorological Probes. The modulator generates and shapes pulses which 100% amplitude modulate an RF carrier. The pulse repetition rate of the modulator which varies from 0 to 950 Hz, is determined by the resistance of the temperature and humidity sensors. The modulator also generates identification frequencies of 1395 Hz, 1630 Hz and 1835 Hz and a reference frequency of 950 Hz. The data, identification frequencies and reference frequency is sequentially telemetered to the ground station when it can be automatically processed. The oscillator can be tuned from 1660 MHz to 1700 MHz and delivers a minimum of 65 mW across the operating band under all operating conditions. The RF signal is fed into a discone antenna having an input impedance of 50 ohms. After testing the entire transmitter is assembled in a protective dielectric housing.

The requirements of the radiosonde are summarized in Table 1.

Table 1. Summary of Requirements for the Radiosonde  
Modulator/Transmitter Module

PARAMETER	VALUE	UNITS
Frequency (Mechanically Tunable)	1680±20	MHz
Power Output (Coaxial Output)	65 min.	mW
Frequency Stability (vs Temperature)	4 max.	MHz
Frequency Shift with Modulation	150 max.	KHz
Pulse Modulation Rates		
Meteorological Data	25 to 950	pps
Identifiers	1395±115	pps
	1630±115	pps
	1835±75	pps
Reference	950±50	pps
Super-regeneration	None	-
Sensor Base Current	75 max.	μA
Transfer characteristic	per para. 3.2.1.12 of SCS-408A	
Weight	150 max.	gms
Operating Conditions		
Supply Voltage	-20 to -30	Volts
	-24 nom.	Volts
Temperature	-70 to +70	°C
Altitude	105,000	ft
Current	100 max.	ma
Pulse Width	60±20	μsec

## 2.1.2 Design Considerations

### 2.1.2.1 General

The major design effort was complete during the preceding reporting period, and by agreement between Rockwell (Collins) and ECOM, all effort on the Radiosonde portion of this MM&T was to end with the completion of the last group of engineering units. The engineering units have been built and the test results are shown in paragraph 2.1.3. The conclusion reached during the Radiosonde development effort was that thick film is a viable replacement for thin film circuits and significant time and cost savings can be realized by using thick film methods.

### 2.1.3 Test Results

Table 2 summarizes the test results for the fourth engineering samples. Construction is identical to that of the third engineering units, except that a chip capacitor (1 $\mu$ F) on the modulator board was replaced with an axial lead device for increased reliability. All units met power output, current, reference frequency and transfer characteristics specifications over the full temperature range. Six units met the frequency stability requirement of 4 MHz over the full temperature range and the remaining four met the spec from -50°C to +70°C but were slightly out of spec between -70°C to -50°C. All units met the pulse width spec.

## 2.2 FM SOURCE

### 2.2.1 Description of the Device

The FM Source is a thick film microwave integrated circuit intended for use as a linear frequency modulated transmitter in applications requiring a rugged, low cost, lightweight device. It consists of a varactor tuned transistor oscillator followed by a transistor power amplifier stage. The oscillator operates at a fixed frequency of 1375  $\pm$  25 MHz and delivers a minimum of 500 mw into a 50 ohm load. The unit is capable of being frequency modulated at any

UNIT S/N	TEST FREQ. (GHz)	POWER OUTPUT @ 25°C (mW)	POWER OUTPUT @ WORST TEMP. (mW)	CURRENT @ WORST TEMP. (mA)	PULSE WIDTH (µSec)	FREQ. STABILITY -70° TO 70°C (MHz)
31	1.68015	116	90	95.5	44	2.13
32	1.68049	149	116	98	44	4.57
33	1.68039	145	111	97	44	4.92
34	1.68040	132	114	94	44	0.63
35	1.68019	114	97	94	43	5.57
36	1.68053	132	104	95	47	2.27
37	1.68072	110	90	92	44	3.04
38	1.68022	111	91	95	42	4.29
39	1.68046	117	104	97	43	3.76
40	1.68002	110	79	96	44	0.86
SPEC	1.68 + .02	N/A	65 MIN.	100 MAX.	60 ± 20	4 MAX.

TABLE 2

RADIOSONDE  
FOURTH ENGINEERING SAMPLES  
TEST SUMMARY

rate up to 1 MHz by application of a signal on a designated input lead. Total frequency deviation is 50 MHz minimum. The unit is housed in a rugged hermetic structure capable of withstanding severe environmental stress.

The requirements for the FM Source are summarized in Table 3.

### 2.2.2 Design Considerations

#### FM Linearity

The importance of the  $\pm 2\%$  second order linearity of the FM Source in system operation has been discussed with HDL. The present Collins oscillator design does not meet this requirement, and the previous RCA circuit would meet  $\pm 2\%$  over only a 35 MHz band and appeared to require a significant amount of post assembly tuning to achieve this limited linearity performance. In order to develop a manufacturable oscillator/amplifier having this high degree of second order linearity, one must first develop an analytical model of the circuit to determine the maximum theoretical bandwidth for a given linearity and, then, be able to evaluate the effect of circuit element variations, variation of varactor diode characteristics and the effect of load variations on the theoretical performance. The synthesis and analysis of a network having an inbedded non-linear element such as a varactor diode cannot be handled by general purpose optimizer programs presently available.

#### Computer Synthesis Program

A new analysis/synthesis program is being generated to synthesize and analyze networks capable of linearizing the reactive tuning portion of the FM Source. This new program will use some presently available optimization sub-routines imbedded in a new structure which will allow program optimization of all components, including the required range of the varactor diode. The technique used in this new program is briefly outlined as follows:

Table 3

## Summary of Requirements for the FM Source

PARAMETER	VALUE	UNITS
RF Frequency	1375 $\pm$ 25	MHz
Power Output	500 Min.	mW
Power Variation over Frequency Range	1 Max.	dB
Modulation		
Type	FM	
Deviation	$\pm$ 25 Min.	MHz
Tuning Voltage	30	Volts p-p
Input Impedance	1000 Min.	ohms
Deviation from constant tuning slope	$\pm$ 2 Max.	%
Input Voltage @ Center Frequency	15 $\pm$ 5	Volts
Operating Conditions		
Supply Voltage	24 $\pm$ .25	Volts
Current @ 24 VDC	175 Max.	ma
Temperature	-40 to + 70	°C
Shock	150 (for 11 msec)	g
Altitude	50,000	ft
Weight	65	grams
AM Noise	-100	dBc
FM Noise	-60	dBc
Frequency Turn On Stability	$\pm$ 2.5	MHz
Power Turn On Stability	$\pm$ 10	%

1. Define a mathematical equation for the C/V relationship of a varactor diode.
2. Determine the reactance vs frequency characteristics for the active portion of the oscillator.
3. Define a tuning network topology, either lumped-element or transmission line form, based on the linear tuning network techniques developed by L. Tozzi.
4. By iterative calculation, determine the resonant frequency of the tuning network/oscillator reactance for a given voltage range and voltage increments.
5. Fit the voltage vs frequency curve found in step 4 to a fourth order polynomial having the form:

$$f = A_0 + A_1 V + A_2 V^2 + A_3 V^3 + A_4 V^4.$$

6. Derivatives of the function generated in step 5 are used to determine the second order linearity, points of minima and maxima, and points of inflection.
7. The tuning range, tuning sensitivity and second order linearity generated in steps 1-6 will be used to direct a synthesis/analysis sub-routine to create an optimum network for a gain center frequency, bandwidth and linearity restriction.

The analysis portion of the program can be used to analyze the effect on linearity and bandwidth of changes in network elements, varactor characteristics and oscillator load variation.

The basic concepts have been proven using a programmable desk calculator routine. Due to limited speed and memory capability, only the analysis portion of the program can be handled by this machine. Final programming is being done on the

Univac 1108 system in the Collins computer center. All circuit elements will be input with the lossy elements and stray reactances normally associated with microstrip circuits. The oscillator model generated by this method will yield the design plan and expected performance objectives for the rework of the FM Source.

#### Snapstrate Design

The first shipment of snapstrates has been received from the vendor and sample lot of substrates was screened to check the tolerances between screens and hole locations. These units have not been built up and tested electrically because of the FM linearity problems. Changes in the circuit configuration will probably require changes in the hole locations on the substrate which will require a new soft tooling and a new lot of substrates.

#### Manufacturing Plan

The manufacturing plan for the Confirmatory Samples of the FM Source has been completed, based on the existing design. Anticipated change in the FM Source design will require only minor changes in this plan which will be submitted with the fourth engineering samples.

#### 2.2.3 Problems

##### FM Linearity

Analysis of the FM linearity problem has been discussed in a previous paragraph. The completion of the fourth engineering samples has been stopped until the linearity problem is resolved.

##### Shock and Spin Test Results

The following units have been returned to Collins for evaluation after shock tests at Harry Diamond Laboratories as indicated:

<u>SN</u>	<u>SETBACK</u>	<u>IMPACT</u>
22	11,470G	< SETBACK
25	11,660G	< SETBACK
23	24,290G	> SETBACK
26	24,670G	>> SETBACK
29	24,770G	>> SETBACK

All units sustained external damage of varying degrees. The output cable separated from the housing on all units except serial number 25. No attempt was made to evaluate serial numbers 23, 26 and 29 since the impact shock is unknown and damage was severe.

Serial numbers 22 and 25 exhibited less damage, although the outer cups were permanently deformed .013 and .022 inches, respectively. This exceeds the deflection of .0051 inches which will withstand without cracking as discussed in Quarterly Report No. 2.

Inspection revealed that the inner and outer cups made of 410 stainless steel had not been heat treated to Rockwell C-41 as specified. However, the calculated maximum dynamic bending stress of 44,360 PSI for a 30,000G shock of 6MS duration is slightly less than the yield strength of 45,000 PSI for the material in an annealed condition. Serial numbers 22 and 25 were subjected to a much lower shock level of 11,470G and 11,660G, respectively. These shock levels should produce a significantly lower bending stress than the yield strength of the annealed material. The deformation of these units indicate an additional external load has been applied to the inner and outer cups, increasing the bending stress and exceeding the yield strength. The samples also show the inner and outer cups deformed concave in opposite directions. This indicates that the potting material used during the shock test has deformed, causing a compressive force on the opposing cups. A shock fixture may be required to eliminate this additional loading.

In addition to the additional loading caused by the potting material, H. Gerlack of Harry Diamond Laboratory indicates there is some concern about the accuracy of "G" levels to which serial numbers 22 and 25 have been subjected.

2.3 MATERIALS EVALUATION

During this reporting period, the evaluation of screened-thru-holes was completed. The results of this experiment are included in the Materials Evaluation Report which is Appendix I of this report and will not be discussed here.

SECTION 3

CONCLUSIONS

3.1 RADIOSONDE MODULATOR/TRANSMITTER

Development of this portion of the program has shown thick film to be a viable method of building this type of microwave oscillator. Further effort would be required to develop techniques for high-volume, high-yield production, but the basic production and manufacturing techniques have been demonstrated.

3.2 FM SOURCE

The added emphasis on second order linearity has caused a delay in the FM Source development program. Analysis and optimization tools must be developed to generate a linearization circuit and to determine the sensitivity of the circuit to element variation before a final design can be made. Previous modeling techniques are not sufficient to generate and evaluate an oscillator with the required linearity.

SECTION 4

PROGRAM FOR NEXT INTERVAL

4.1 FM SOURCE

The following objectives are planned for the next reporting period:

1. Complete the analysis and optimization computer program for linearization network.
2. Determine the best network configuration for optimum linearity.
3. Build and evaluate linear network oscillator/amplifier.
4. Fabricate and test fourth set of engineering samples.
5. Repeat shock and spin test on properly heat treated modules.

## SECTION 5

## 5.0 IDENTIFICATION OF PROJECT PERSONNEL

The personnel directly related to the ECOM project are listed in Table 4. Resumes of personnel new to the project are included.

TABLE 4

## Identification of Project Personnel

<u>Personnel</u>	<u>Titles</u>
R. E. Shipley	Program Manager
L. D. Bachman	Project Engineer
J. K. McCoy	Project Engineer
K. W. Hoover	Design Engineer (Elect.)
L. G. Ward	Design Engineer (Mech.)
H. D. Jenkins	Mechanical Engineer/Group Head
R. Schultz	Senior Process Engineer
C. L. Fox	Senior Technician
V. Miller	Assembly Technician
D. Warner	Thick Film Technician

L. D. BACHMAN

POSITION: Project Engineer, RF Products Department  
Hybrid Microelectronics Division

EDUCATION: BSEE, Oklahoma State University,  
Stillwater, Oklahoma, 1965.

Mr. Bachman joined Collins in 1965. Since that time, his design activities have included development of high and medium power broadband UHF amplifiers, low-noise GaAs FET microwave amplifiers, phase-locked L-band oscillators, broadband HF amplifiers and other rf components. He has also had experience in VHF oscillator design, digital decoding systems and VLF navigation equipment design. Specific project engineering responsibilities include the development of 100 Watt UHF power amplifier modules for the ARC 172 and E2-C/53-A UHF transceivers as well as the development of a selective calling system for a VHF marine band transceiver and the development of a broadband amplitude modulator for automatic testing application.

Robert E. Schultz

Position: Process Engineer, Hybrid Microelectronics Division

Mr. Schultz joined Collins Radio Group in January, 1977, and has been assigned to the Hybrid Microelectronics Division. He is working on process development for RF hybrid circuits utilizing either thick or thin film technique.

Education: Mr. Schultz received his Master of Science and Bachelor of Science degrees from the University of Washington, Seattle, Washington in Ceramic Engineering in 1966 and 1963 respectively.

Related Experience: Prior to joining Collins Radio Group Mr. Schultz was at Texas Instruments, Dallas, Texas and worked on process development of thick film and thin film hybrid circuits. He was responsible for processes and hybrid designs for the Customer Engineering Center. His responsibilities included design of hybrids for high g loading, custom packaging for new, advanced integrated circuits and continual evolution of new thick film materials and processes for improved yields and cost reduction.

From February, 1966, to January, 1973, Mr. Schultz was a project engineer at the Semi Conductor Products Division of Motorola, Phoenix, Arizona. He was responsible for development glasses, metallization used for ceramic I/C packages and hybrid circuits.

SECTION 6  
DISTRIBUTION LIST

	<u>No. of Copies</u>
Commander US Army Materiel Development and Readiness Command ATTN: DRCMT 5001 Eisenhower Avenue Alexandria, VA 22333	1
NASA Scientific & Tech Info Facility PO Box 8757 Baltimore/Washington Int'l Airport MD 21240	2
Advisory Group on Electron Devices 201 Varick Street, 9th Floor New York, NY 10014	2
Defense Documentation Center ATTN: DDC-TCA Cameron Station (Bldg 5) Alexandria, VA 22314	2
Department of Defense Deputy for Science & Technology Ofc Assist Sec Army (R&D) Washington, DC 20310	1
Commander Picatinny Arsenal ATTN: SARPA-FR-S-P Dover, NJ 07801	1
Director, US Army Ballistic Rsch Labs ATTN: DRXBR-LB (Bldg 305) Aberdeen Proving Ground MD 21005	1
Cdr, US Army Research Office ATTN: DRXRO-IP PO Box 12211 Research Triangle Park, NC 27709	1
Commander US Army Missile Command Redstone Scientific Info Ctr ATTN: Chief, Document Section Redstone Arsenal, AL 35809	1
Commander Harry Diamond Laboratories ATTN: Library 2800 Power Mill Rd. Adelphi, MD 20783	1

	<u>No. of Copies</u>
U.S. Army Production Equipment Agency ATTN: DRXPE-MT Mr. Charles E. McBurney Rock Island, IL 61201	2
Harry Diamond Labs 2800 Powder Mill Road ATTN: DRXDO-PP Mr. Julius Hoke Adelphi, MD 20783	1
U.S. Army Missile Command ATTN: DRSMI-RLS Mr. Richard Kotler Redstone Arsenal, AL 35805	1
U.S. Army Missile Command ATTN: DRSMI-RGP Mr. Victor Ruwe Redstone Arsenal, AL 35805	1
U.S. Army Missile Command ATTN: DRSMI-RGR Mr. Jake Herron Redstone Arsenal, AL 35805	1
Commanding Officer U.S. Army Electronics Command Fort Monmouth, NJ 07703 ATTN: I. Pratt	1
Commander Harry Diamond Labs 2800 Powder Mill Road ATTN: DRXDO-RAA Mr. H. Gerlich Adelphia, MD 20783	1
Department of Navey Office of Naval Research Code 427 Arlington, VA 22217	1
Department of Navy Naval Ships Engineering Center ATTN: Code 6157D Prince Georges Center Huattsville, MD 20782	1
Cdr, Naval Surface Weapons Ctr White Oak Laboratory Library Code WX-21 Silver Spring, MD 20910	1

	<u>No. of Copies</u>
Commandant, Marine Corps HQ, US Marine Corps ATTN: Code LMC Washington, DC 20380	1
Commander Naval Air Systems Command ATTN: AIR-310B Washington, DC 20361	1
Commander Naval Air Systems Command ATTN: AIR-954 Washington, DC 20361	1
Commander Naval Air Systems Command ATTN: AIR-360G Washington, DC 20361	1
Commander Naval Air Systems Command ATTN: AIR-52022 Washington, DC 20361	1
Commander Naval Avionics Facility ATTN: D. Tague 21st & Arlington Avenue Indianapolis, IN 42618	1
Director Naval Research Laboratory ATTN: Dr. L. Jarvis, Code 617 Washington, DC 20390	1
Director Naval Research Laboratory ATTN: Dr. W. Weisenberger, Code 5215 Washington, DC 20390	1
Director Naval Research Laboratory ATTN: Dr. Paul Becker, Code 2627 Washington, DC 20390	
Commander Naval Weapons Center ATTN: Dr. F. Essig, Code 601 China Lake, CA 93555	1

	<u>No. of Copies</u>
Commander Naval Electronics Lab. Ctr. ATTN: Roy Potter, Code 2600 San Diego, CA 92152	1
Commander Naval Electronics Lab. Ctr. ATTN: Dr. Dean McKee, Code 4800 San Diego, CA 92152	1
Commander Naval Electronics Lab. Ctr. ATTN: Library San Diego, CA 92152	
Commander US Navy Material Ind. Res. Office ATTN: Code 226 NAVMIRO Mr. Oscar Wilskar Philadelphia, PA 19112	1
Commanding Officer Code 7024, Bldg. 2906 Naval Weapons Support Ctr. Crane, Indiana 47522 ATTN: C.R. Patel	
Director, ARPA 1400 Wilson Blvd. ATTN: Dr. M. Stickley Arlington, VA 22209	1
HQDA (DAMA-ARP) Dr. F. D. Verderame Washington, DC 20310	1
Commander Rom Air Dev Center/RBRP ATTN: DAPC/RBRM Mr. J. Ferrell Griffiss Air Force Base, NY 13341	1
Dept. of Air Force Rome Air Development Center ATTN: Documents Library (TILD) Griffiss AFB, NY 13441	1
Dept. of Air Force HQ ESD (DRI) L. G. Hanscom AFB Bedford, MA 01730	1

	<u>No. of Copies</u>
Commander Air Force Avionics Laboratory Wright-Patterson AFB, OH 45433 ATTN: H. Steenbergen, AVTM	1
Commander AFML/LTE (Dr. Larry Yarrington) Wright-Patterson Air Force Base Ohio 45433	1
Commander AFML/LTE (Donald Hutchens) Wright-Patterson Air Force Base Ohio 45433	1
National Bureau of Standards Bldg. 225, Rm. A-331 ATTN: Mr. G. Harmon Washington, DC 20234	1
Metals and Ceramics Inf Ctr Battelle 505 King Avenue Columbus, OH 43201	
Bell Laboratories Whippany Road ATTN: M.A. Rello, Libr. Whippany, NJ 07981	1
Bell Laboratories ATTN: Dr. H. Cohen Allentown, PA 18103	1
Bell Laboratories ATTN: Dr. Y. Kim Allentown, PA 18103	1
Cermalloy 14 Fayette Street ATTN: F. E. Buzan, V.P. Conshohocken, PA 19428	1
E. I. DuPont Electrochemical Department ATTN: Dr. L. C. Hoffman Wilmington, DE 19898	1
E. I. DePont Electronics Products Division ATTN: Dr. F. J. Anders, Jr. Niagara Falls, NY	1

	<u>No. of Copies</u>
Engelhard Industries Division 1 West Center Avenue ATTN: S. S. Cole Marketing Manager East Newark, NJ 07029	1
Mr. J. Schmidt General Dynamics Corp. PO Box 81127 Microelectronics Center San Diego, CA 92138	1
Hybrid Microcircuit Technology Div. 2431 Sandia Laboratories ATTN: Dr. R. K. Traeger Albuquerque, NM 87115	1
Hybrid Microcircuit Technology Div. 2432 Sandia Laboratories ATTN: Dr. J. T. Grissom Albuquerque, NM 87115	1
Hughes Ground Systems Group ATTN: J. R. Kubik Fullerton, CA 92634	1
Honeywell Hybrid Microelectronics ATTN: Dr. Rudolph G. Oswald 13350 US 19 St. Petersburg, FL 33733	1
IBM, Dept LO4 Bldg. 052 Box 390 ATTN: Dr. K. L. Mittal Poughkeepsie, NY 12602	1
IBM Components Division Dept. 931/Bldg. 800 101 ATTN: Dr. L. F. Miller Hopewell Junction, NY 12533	1
Jet Propulsion Laboratory 4800 Oak Grove Dr. ATTN: Lois Baird, Libr. Pasadena, CA 91103	1

	<u>No. of Copies</u>
Johns Hopkins APL 11100 Johns Hopkins Place ATTN: D. Zimmerman	1
Mansanto Research Corporation Dayton Laboratory 1515 Nicholas Road ATTN: Dr. R. Janowiecki Dayton, OH 45477	1
Mr. W. H. Armbruster Motorola Inc. 2200 W. Broadway Mesa, AZ 85036	1
Owens-Illinois, Inc. Electronic Materials, Box 1035 ATTN: R. Dietz Toledo, OH 43561	1
Purdue University Electrical Engineering Dept. ATTN: Dr. Robert Vest School of Materials Engineering W. Lafayette, IN 47907	1
Materials Research Laboratory Department of Ceramic Science Pennsylvania State University ATTN: Prof. J. V. Biggers University Park, PA 16802	1
Raytheon Company Missile Systems Div. West Andover Plant ATTN: W. L. Mularz Andover, MA 01810	1
Librarian Raytheon Semiconductor Mountain View, CA 94040	1
Rockwell International Autonetics Division Anaheim, CA 92803 ATTN: J. Licari-Microcircuits	1
RCA Defense Electronic Products ATTN: Mr. E. Waldron PO Box 588 Burlington, MA 01801	1

	<u>No. of Copies</u>
RCA Laboratories ATTN: T.T. Hitch Princeton, NJ 08540	1
3M Company Manufactures Rd & Peerless Street ATTN: Mr. Thomas McKinney Chatanooga, TN 37405	1
Western Electric Engineering Research Center Box 900 ATTN: Dr. D. J. Shanefield	1
Western Electric Engineering Research Center Box 900 ATTN: Dr. J. R. Piazza Princeton, NJ 08540	1
Westinghouse P.O. Box 746-M.S. 777 ATTN: L. Razzetti Baltimore, MD 21203	1
Westinghouse P.O. Box 746-M.S. 777 ATTN: CA Harper Baltimore, MD 21203	1
Westinghouse D&E Systems Ctr. P.O. Box 1897, MS 717 Baltimore, MD 21203 ATTN: Dr. Ted Foster	1

SECTION 7

APPENDIX I

MATERIALS EVALUATION REPORT

64

TABLE OF CONTENTS

<u>Section</u>	<u>Page</u>
7.1 INTRODUCTION.....	7-1
7.2 METALLIZATION ADHESION.....	7-6
7.3 WIRE BONDABILITY.....	7-22
7.4 ELECTRICAL EVALUATION.....	7-24
7.5 CONCLUSIONS.....	7-31
7.6 APPENDIX I-A.....	7-32
7.7 APPENDIX I-B.....	7-37
7.8 APPENDIX I-C.....	7-40

## LIST OF ILLUSTRATIONS

<u>Figure</u>	<u>Page</u>
7-1 Adhesion of Cermalloy 7029 Copper Using 62% Sn, 36% Pb, 2% Ag Solder.....	7-8
7-2 Adhesion of Dupont 9770 PtAg Using 62% Sn, 36% Pb, 2% Ag Solder.....	7-10
7-3 Adhesion of Dupont 9308 PdAg Using 62% Sn, 36% Pb, 2% Ag Solder.....	7-12
7-4 Adhesion of Dupont 9885 PtAu Using 62% Sn, 36% Pb, 2% Ag Solder.....	7-13
7-5 Adhesion of Cermalloy 7029 Copper vs Solder Type.....	7-17
7-6 Adhesion of Dupont 9770 PtAg vs Solder Type.....	7-18
7-7 Adhesion of Dupont 9308 PdAg vs Solder Type.....	7-19
7-8 Adhesion of Dupont 9885 PtAu vs Solder Type.....	7-21
7-9 Q vs Frequency for Thick Film Conductors.....	7-29
7-10 Q vs Sheet Resistivity for Thick Film Conductors.....	7-30

## 7.1 INTRODUCTION

The purpose of this investigation was to determine the compatibility of specific thick film conductors for use in high frequency hybrid circuits. This evaluation did not include all thick film material presently on the market, nor were all the processing variations investigated for determining optimum results. A typical material from each of the major thick film conductor systems was evaluated. Thick film inks were chosen so that each bonding mechanism - reactive, mixed and frit - was also investigated.

The conductors chosen and their respective bonding mechanism are shown in Table 7-1. From manufacturers' published data, the gold, PtAg and copper inks have the highest electrical conductivity. PtAu are the most solder leach resistant and have the highest D.C. resistivity. Copper requires nitrogen atmosphere during firing to prevent oxidation at elevated temperatures. Resistivity of copper conductors is low and solder leach resistance is good. PdAg is an economical thick film material but has a higher resistivity than the golds or PtAg's and also has a decrease in aged adhesion using tin bearing solders. The conductors chosen for the evaluation cover the range of resistivity and metal types presently available.

Bonding mechanism of thick film materials to alumina substrates is a complex reaction involving the melting of glasses, wetting characteristics of glass to ceramic and metal particles, and the formation of compounds with the ceramic. Present thick film inks can be divided into three categories: reactive bonded, mixed bonded and frit systems. Reactive bonded thick film inks do not have glass forming compounds present. Instead, reactive components are added to the conductor material; during firing these materials

TABLE 7-1

THICK FILM INKS  
USED IN MATERIALS EVALUATION

SUPPLIER	NUMBER	MATERIAL	BOND MECHANISM
Electro-Oxide	6990	Gold	Reactive
Electro-Oxide	1130	PtAg	Reactive
Cermalloy	7029	Copper	Mixed
Dupont	9791	Gold	Mixed
Dupont	9885	PtAu	Mixed
Dupont	9770	PtAg	Mixed
Dupont	8308	PdAg	Frit

form a spinel compound with alumina. The reactive component is usually copper with other minor additions to insure satisfactory reaction. These materials generally have a narrow firing range, and required peak temperature is close to the melting point of the conductor; i.e., a reactive bonded gold requires a firing temperature of 1000°C and reactive bonded PtAg requires 925°C. A fritted conductor contains glass which during firing becomes fluid, wets the metal particle and reacts with the glass in the alumina substrate to form a bond of the metal particle to the base material. Firing temperature is less critical and depends only on reaching adequate temperature for the glass to become fluid. A mixed bonded system is a combination of a glass frit and a reactive component: The glass reacts with the substrate, as in a frit bonded system, but also acts as a catalyst for the formation of the spinel structure of the reactive component. These systems have a wider firing temperature than the reactive bonded system. Adhesion of the mixed bonded system is generally better than a frit bonded system of the same metal family. Generally, adhesion and electrical conductivity will increase with decreasing frit content for a given conductor type.

Substrates used for this evaluation were obtained from two suppliers: 3M, Technical Ceramics Products Division, Laurens, South Carolina and Materials Research Corporation, Orangeburg, New York. Three different substrate types were used: 3M 614, 96% alumina with a nominal surface of 34 micro-inches and an average grain size of 10-12 microns; MRC 96% alumina with a surface finish of 6-8 micro-inches and grain size of 3-4 microns; and MRC 99.5% superstrate alumina with a surface finish of 3-4 micro-inches and grain size of less than two microns.

Specific reactions between thick film inks and the three substrate types are complex, but some general predictions can be made. Frit bonded inks should

react adequately with the 96% aluminas and form an adherent conductive film. There is enough glass (4-8 percent) in the 96% alumina to react with the glass frit in the ink to insure proper adherence. For the 99.5% alumina, insufficient glass is present to obtain adequate adherence. For a reactive bonded system, the surface area of the alumina, or grain size, becomes important. The larger surface area, fine grain alumina, should show higher adhesion provided the glass present in the alumina does not interfere with the copper aluminate spinel formation. More alumina surface is available for reaction with the copper in the reactive system. Adhesion on the large grain 96% alumina should be lower due to less alumina surface area available for bonding. Mixed bonded systems should have good adhesion on all three types of alumina since they are bonded both by a reactive component and a glass frit. Electrical conductivity should not vary significantly with substrate type using the same thick film material.

Evaluation of the thick film material was done in two areas: adhesion testing and electrical testing. Adhesion testing was performed using a wire pull test; wire was attached using a soft solder. Samples were aged at 150°C for 48 hours to determine the effect of high temperature storage on adhesion. For adhesion testing of gold conductors, Au-Sn solder was used since lead-tin solders leach gold too rapidly to obtain meaningful adhesion data. Conventional thermo-compression wire bonding was done to all conductor materials to determine compatibility for chip and wire type hybrid circuits. Electrical measurements consisted of a D.C. resistivity measurement, continuity check for screened-thru-hole metallization, and Q measurements at 2, 4 and 8 GHz. All procedures for fabrication of test samples are in the appendices.

All patterns for testing were screened through a 325 mesh screen with a .0005 inch emulsion. This procedure resulted in a fired film thickness of 11-13 microns. Samples were fired following manufacturers' recommendations where possible.

Testing of these selected thick film conductors was designed to demonstrate compatibility of these materials with assembly techniques and provide a hybrid circuit with desired electrical performance.

## 7.2 METALLIZATION ADHESION

The purpose of the adhesion tests on thick film conductors was to determine the effect of substrate type and solder type on the initial and aged adhesion. Samples were tested initially and after thermal aging for 48 hours at 150°C. Soft solders were used in these tests except for the gold conductors where a hard, gold-bearing solder was used. Table 7-2 shows the solder compositions used and their respective melting points.

As previously discussed, the bonding mechanism of the thick film conductor will determine the compatibility of the ink with the substrate types.

Figures 7-1 thru 7-4 show initial and aged (150°C, 48 hours) adhesion of four thick film inks on the three substrate types previously described. These figures show the average strength and  $\pm \sigma$ . All samples were soldered using 62% Sn, 36% Pb, 2% Ag solder. The procedure for fabrication of test samples is described in Appendix I. All materials were fired using standard profiles when possible. The Cermalloy 7029 copper required a nitrogen ambient during firing, and the Electro-Oxide 6990 gold required significantly higher temperature for proper firing.

Figure 7-1 shows the adhesion of Cermalloy 7029 copper as a function of aging and substrate type. Average initial adhesion on all three substrate types is excellent. The higher values occurring on the 96% aluminas indicate the glass in the system reacts with glass in the alumina to serve as a catalyst for creation of the solid state reaction between active materials in the ink and alumina. This is confirmed by the lower adhesion on MRC 99.5% superstrate alumina where a low initial average strength is observed and there is a larger spread in strength values. Aged adhesion dropped dramatically on

TABLE 7-2

COMPOSITION AND MELTING POINT OF SOLDERS  
USED FOR CONDUCTOR ADHESION TESTING

COMPOSITION	MELTING POINT
95% Sn 5% Ag	220°C
93.5% Pb 5% Sn 1.5% Ag	280°C
63% Sn 37% Pb	180°C
62% Sn 36% Pb 2% Ag	179°C
80% Au 20% Sn	280°C

ADHESION OF CERMALLOY 7029 COPPER  
USING 62% Sn, 36% Pb, 2% Ag SOLDER

FIGURE 7-1

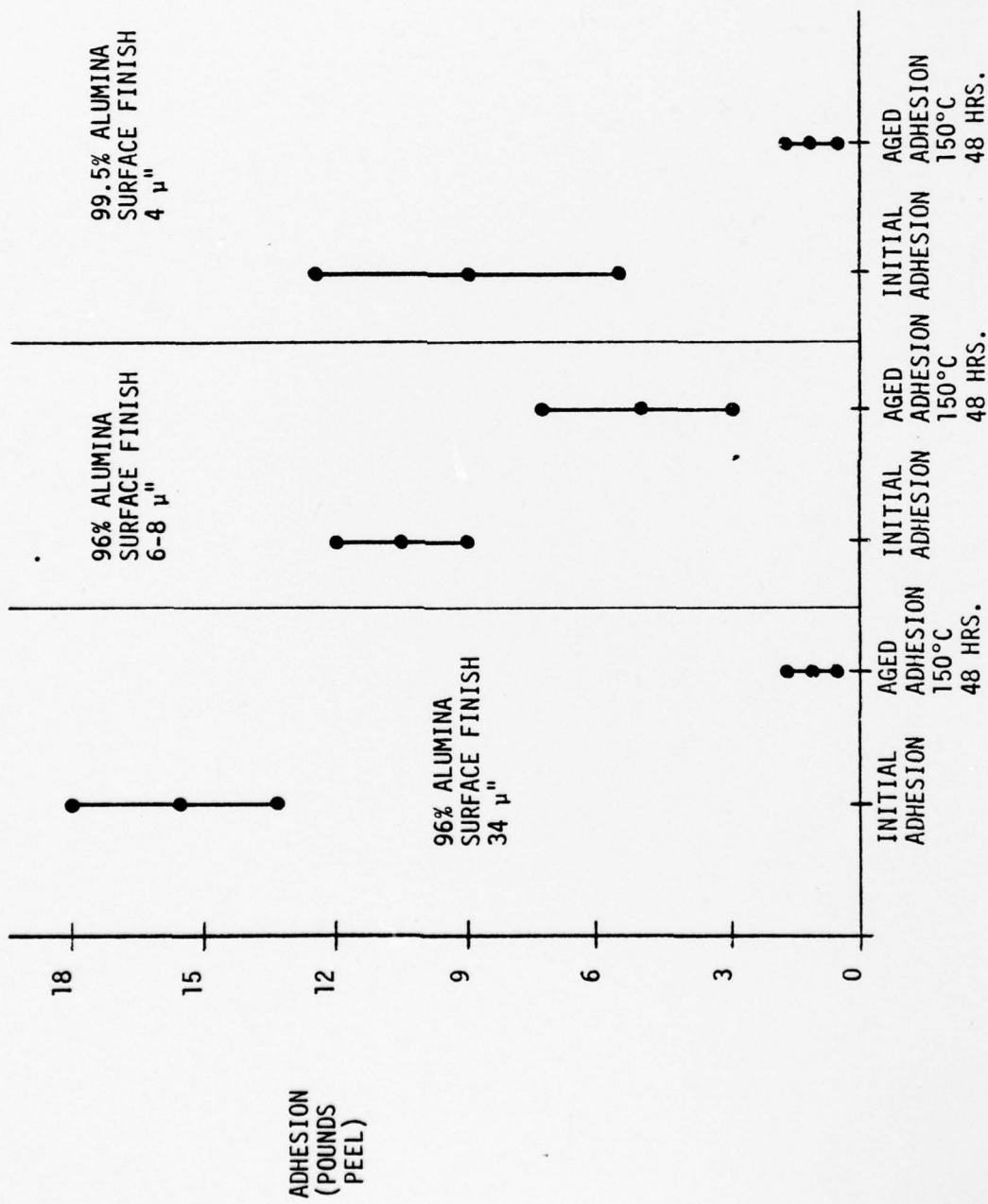

all substrate types. Communications with Cermalloy indicated some explanation for this rather surprising behavior. First, they believed the solder flux that was used in this experiment was too active. They recommend the use of Alpha 711 instead of Kester 1544. The major factor for aged adhesion decreasing was due to the fired conductor thickness. For good aged adhesion, Cermalloy stated the conductor thickness should be about 20 microns rather than the 11-13 micron conductor thickness of these samples. This implies that during aging solid state reactions are occurring which leach the solder and seriously affect the bonding mechanism. Aging the samples only 20°C below the melting point of the solder further accelerated the loss of adhesion. To achieve a 20 micron fired film thickness, a dry print thickness of 30-35 microns is necessary. A dry print thickness in this range would seriously impair our ability to define small accurate geometries. Further investigation of fired thickness, definition and aged adhesion would be required to determine optimum processing conditions.

Figure 7-2 shows adhesion, both initial and aged, for Dupont 9770 PtAg. The average adhesion and  $\pm \sigma$  limits are shown. The data is quite similar to the mixed bonded copper system. Initial adhesion is satisfactory and aged adhesion drops to an unacceptable low value. Initial adhesion on the 96% alumina once again is higher than the 99.5% alumina, indicating the glass in the ink reacts with the glass in the alumina which results in higher adhesion. The quantity of glass in the 99.5% alumina is not sufficient for this reaction to occur, and therefore a lower adhesion results. A finer grained 96% alumina with surface finish of 6-8 micro-inches showed the highest initial adhesion. The combination of fine grain with proper glass content on this material resulted in the highest adhesion with our standard furnace profile. Aged adhesion decreased due to the thickness of the fired film, 11-13 microns. Further

FIGURE 7-2

ADHESION OF DUPONT 9770 PtAg  
USING 62% Sn, 36% Pb, 2% Ag SOLDER

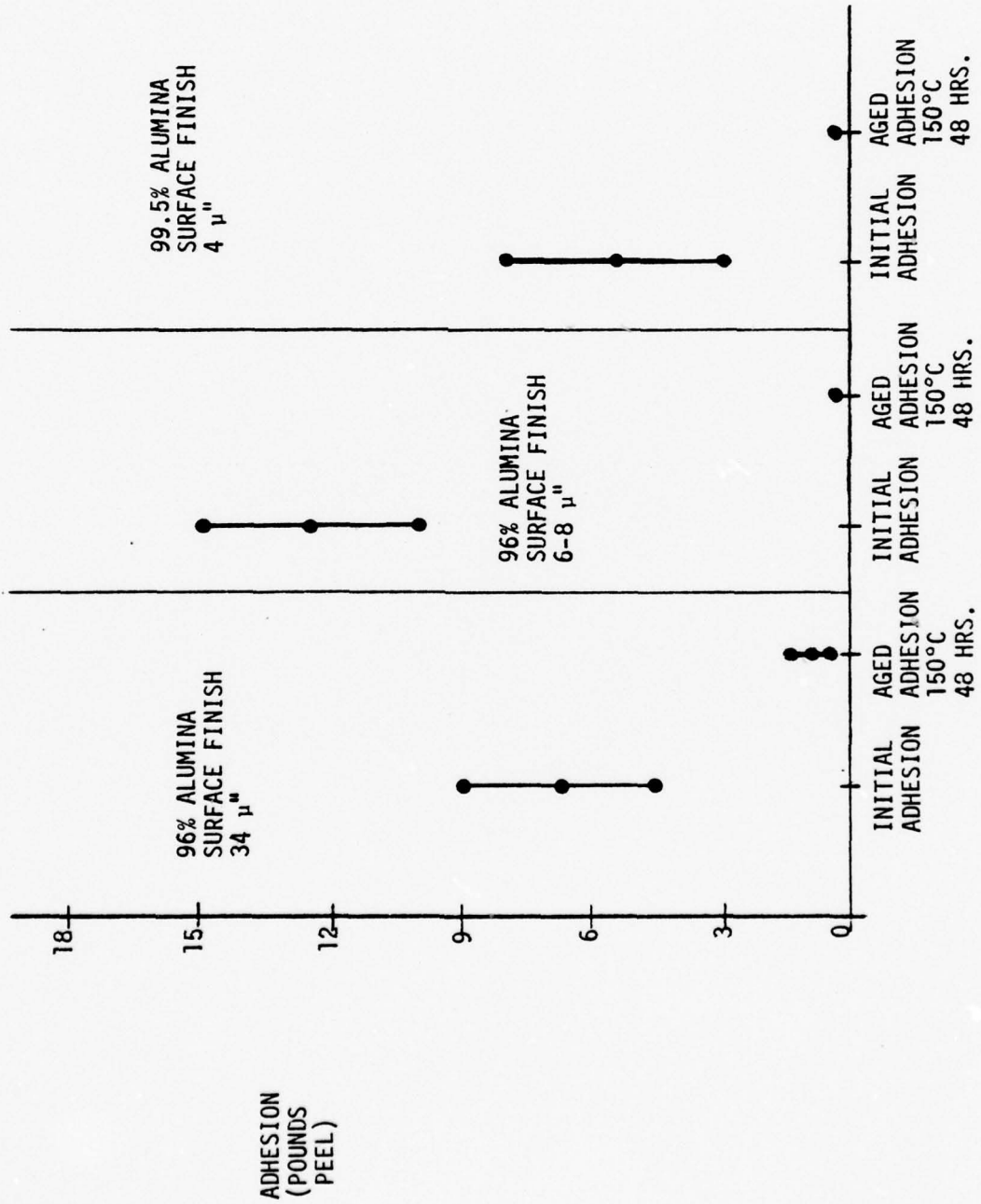

investigation of fired thickness, firing temperature, line definition and aged adhesion is required to optimize process conditions.

Figure 7-3 is a plot of adhesion of Dupont 9308 PdAg. This material reacted in a predictable fashion. Initial adhesion of this fritted system is best on the 96% aluminas. Specifically, this material was formulated for optimum results on 3M 614 96% alumina. Therefore, initial adherence was best on the 3M 34 micro-inch surface finish material. Adhesion on the 99.5% alumina is typically lower due to the bonding mechanism of this frit system. The glass in the thick film ink does not react properly with the 99.5% alumina for maximum adherence. Aged adhesion decreases, as expected, due to a solid state reaction between palladium and tin in lead-tin solders. For this PdAg ink, the decrease in adhesion on aging corresponds well to data published by Dupont. This material is acceptable for hybrid use on the 96% alumina substrates tested but cannot be reliably used on 99.5% alumina substrates.

Figure 7-4 shows adhesion of Dupont 9885 PtAu. Average adhesion and  $\pm \sigma$  are plotted for each substrate type. Initial adhesion was very consistent with all substrate types tested. Aged adhesion on the 96% aluminas showed minimal change. On the 99.5% alumina, a drop in aged adhesion was observed. On the 96% alumina, the glass in the ink reacts with the glass in the alumina, promoting the reactive bond; hence, good initial adhesion results. This reaction does not occur as readily on the 99.5% alumina, and aging of the solder conductor disrupts the bonding mechanism and lowers the aged adhesion. Since there are no intermetallic compounds formed during aging between the conductor and solder, aged adhesion is almost the same using a 96% alumina.

No adhesion tests were conducted with soft solders to gold metallization. Although a skilled operator can make a connection using this metallurgical

FIGURE 7-3

ADHESION OF DUPONT 9308 PdAg  
USING 62% Sn, 36% Pb, 2% Ag SOLDER

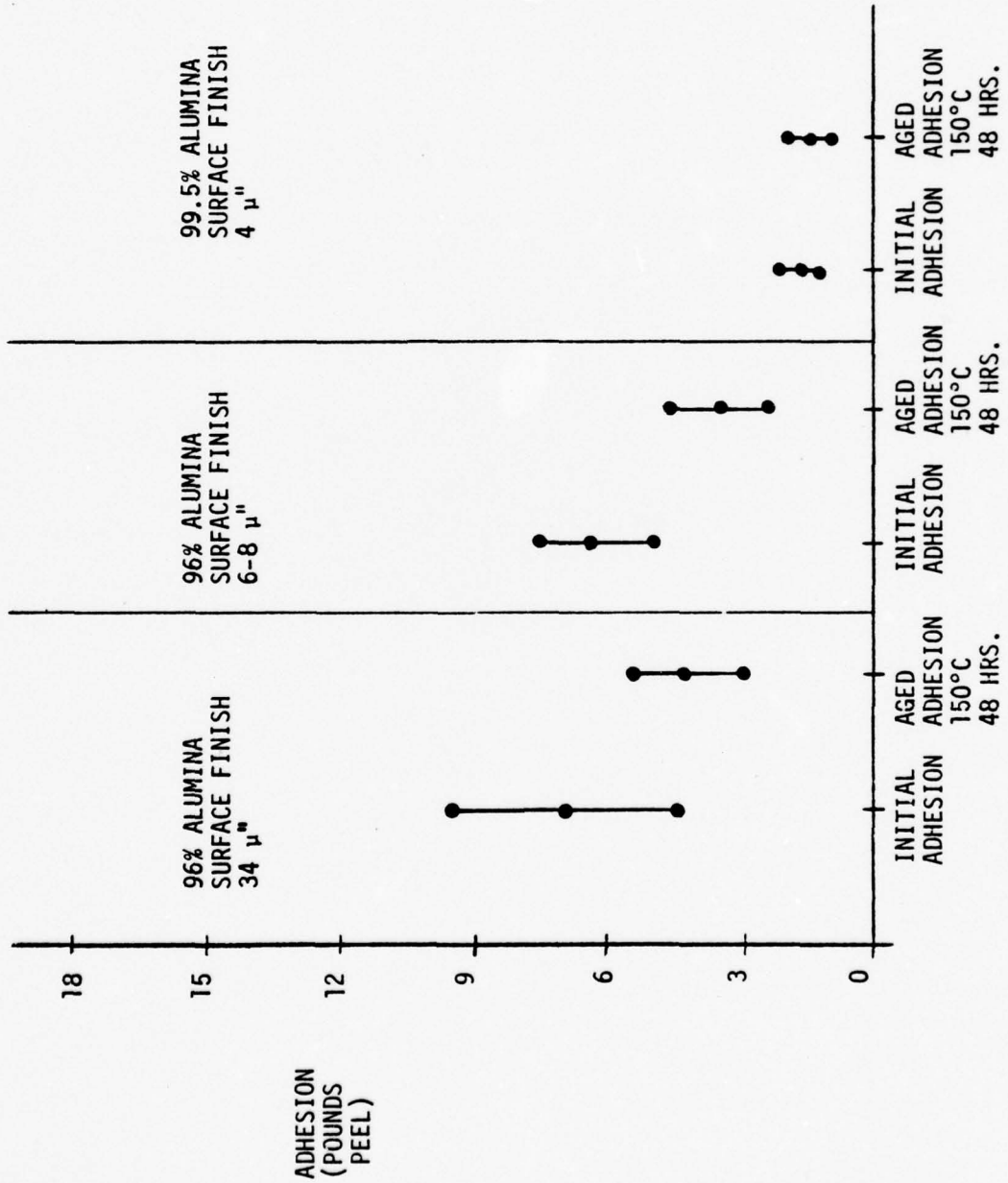
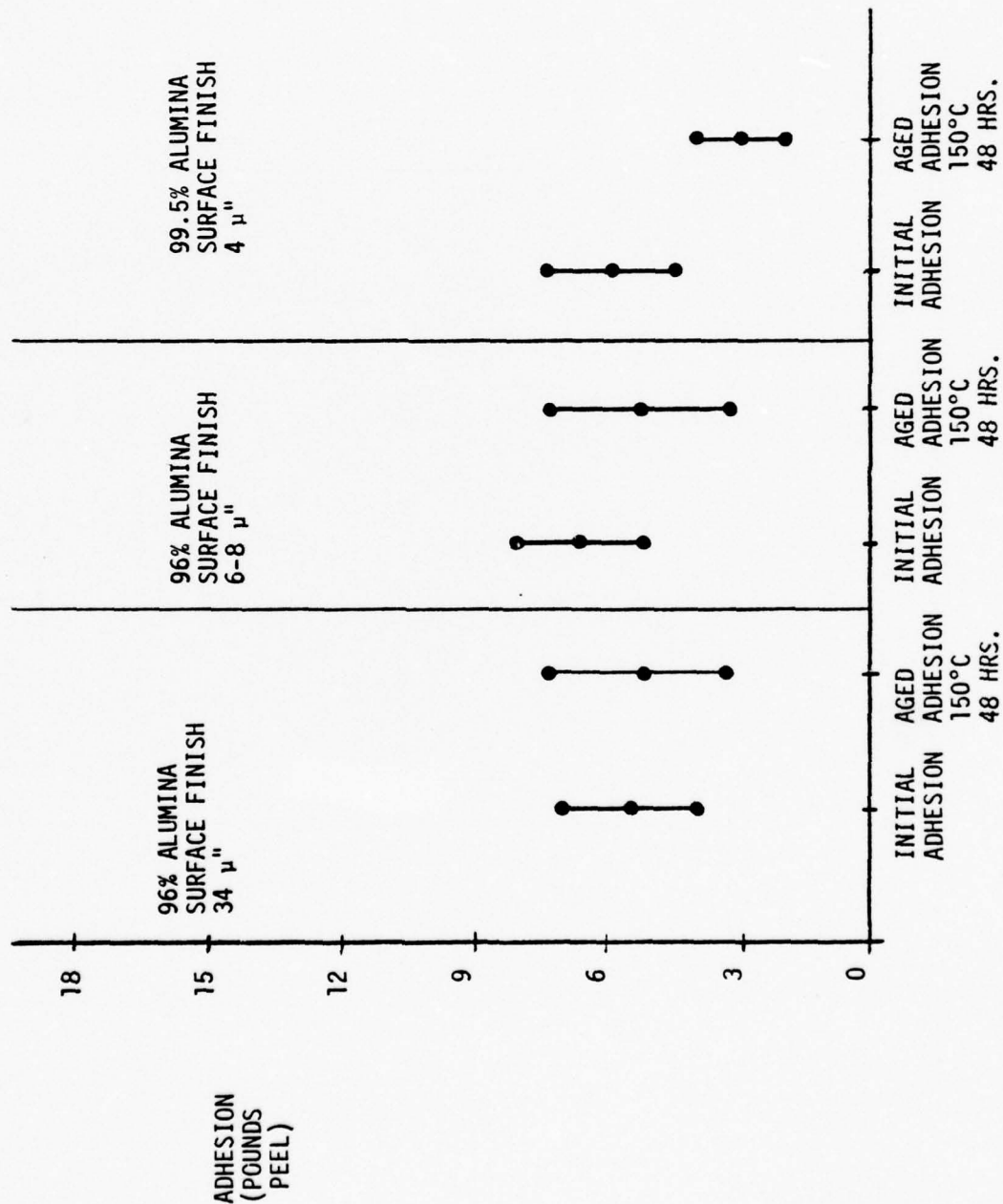

FIGURE 7-4

ADHESION OF DUPONT 9885 PTAU  
USING 62% Sn, 36% Pb, 2% Ag SOLDER



combination, it is not recommended as a production technique. Some adhesion testing was done on gold conductors using 80% Au - 20% Sn solder. The data is summarized in Table 7-3. No aged adhesion testing was done. This limited data suggests the mixed bonded Dupont 9791 gold reacts better with the substrate material at the firing profile used - 850°C. The Electro-Oxide 6990 gold is a frittless system and firing temperature is extremely critical. Recommended firing temperature is 980°C - 1020°C. The Electro-Oxide gold was fired in our laboratory BTU furnace at 985°C, the maximum temperature for this furnace. If we could have achieved a 1000°C furnace profile, higher adhesion values would be expected from this system. Therefore, adhesion comparison of these two golds indicates the Dupont gold had better substrate adhesion under the firing conditions of this experiment. Due to the unique, high-firing temperature of the Electro-Oxide 6990 gold, this material is not compatible with our present standard furnace profiles.

Adhesion testing was done on Electro-Oxide 1130 PtAg. The adhesion was very poor when fired with our standard 850°C furnace profile. This conductor, according to Electro-Oxide, requires a 925°C temperature profile for satisfactory adherence. Electro-Oxide 1130 PtAg is a frittless conductor, and the maximum firing temperature is critical. The required profile, 925°C for ten minutes, is not a standard in our facility at this time; therefore optimum processing (i.e., adherence) was not achieved. During screen printing, this material exhibited excellent line definition and electrical measurements which are discussed later indicate this could be a good conductor for use in high frequency circuits. Further work would be required to define process parameters before use of this material in hybrid circuits.

The next series of adhesion tests on soft solderable conductors varied the tin content since some interest was indicated very early in the program in

TABLE 7-3

ADHESION CHARACTERISTICS OF THICK FILM GOLD  
USING 80% Au - 20% Sn

METALLIZATION	ADHESION (POUNDS, PEEL STRENGTH)		
	LOW	AVERAGE	HIGH
ELECTRO-OXIDE 6990 Au	0	1.30	1.75
DUPONT 9791 Au	3.25	5.08	6.75

in the use of various soldering temperatures in the construction of hybrid circuits. The data is presented in Figures 7-5 thru 7-8. All conductors were printed with a 325 mesh screen with .0005 inch emulsion, resulting in a fired thickness of 11-13 microns. Samples were processed as outlined in Appendix I-A. All samples were fabricated on 3M 614 96% alumina substrates.

Figure 7-5 is a plot of Cermalloy 7029 copper vs adhesion as a function of solder type. The high, low and average adhesions are shown. Initial adhesion appears to be more a function of the melting point of the solder. Aged adhesion shows a significant decrease due to film thickness and solid state diffusion as explained earlier when 62% Sn, 36% Pd, 2% Ag adhesion results were discussed.

Figure 7-6 shows adhesion of Dupont 9770 PtAg. The high, low and average adhesions are plotted. The initial adhesion on the lower melting point solders are satisfactory. Aged adhesion drops dramatically, indicating solid state diffusion and disruption of the bond mechanism in the fired conductor. The high temperature solder, 93.5% Pb, 5% Sn, 1.5% Ag, with melting point 280°C evidently severely leached the conductor, causing immediate and permanent loss of adhesion.

Figure 7-7 is a plot of adhesion for Dupont 9308 PdAg. The high, low and average values are shown for each solder type and initial and aged adhesion. Initial adhesion values are lower than expected from Dupont product literature. This could be due to some leaching of the solder during attachment of wires for adhesion testing. Variation in solder temperature and time could cause the initial adhesion to be low. Aged adhesion values behaved as expected and according to other published literature. As the tin content of the solder increases, aged adhesion decreases. This is due to brittle

FIGURE 7-5

ADHESION OF CERMALLOY 7029 Cu  
VS  
SOLDER TYPE

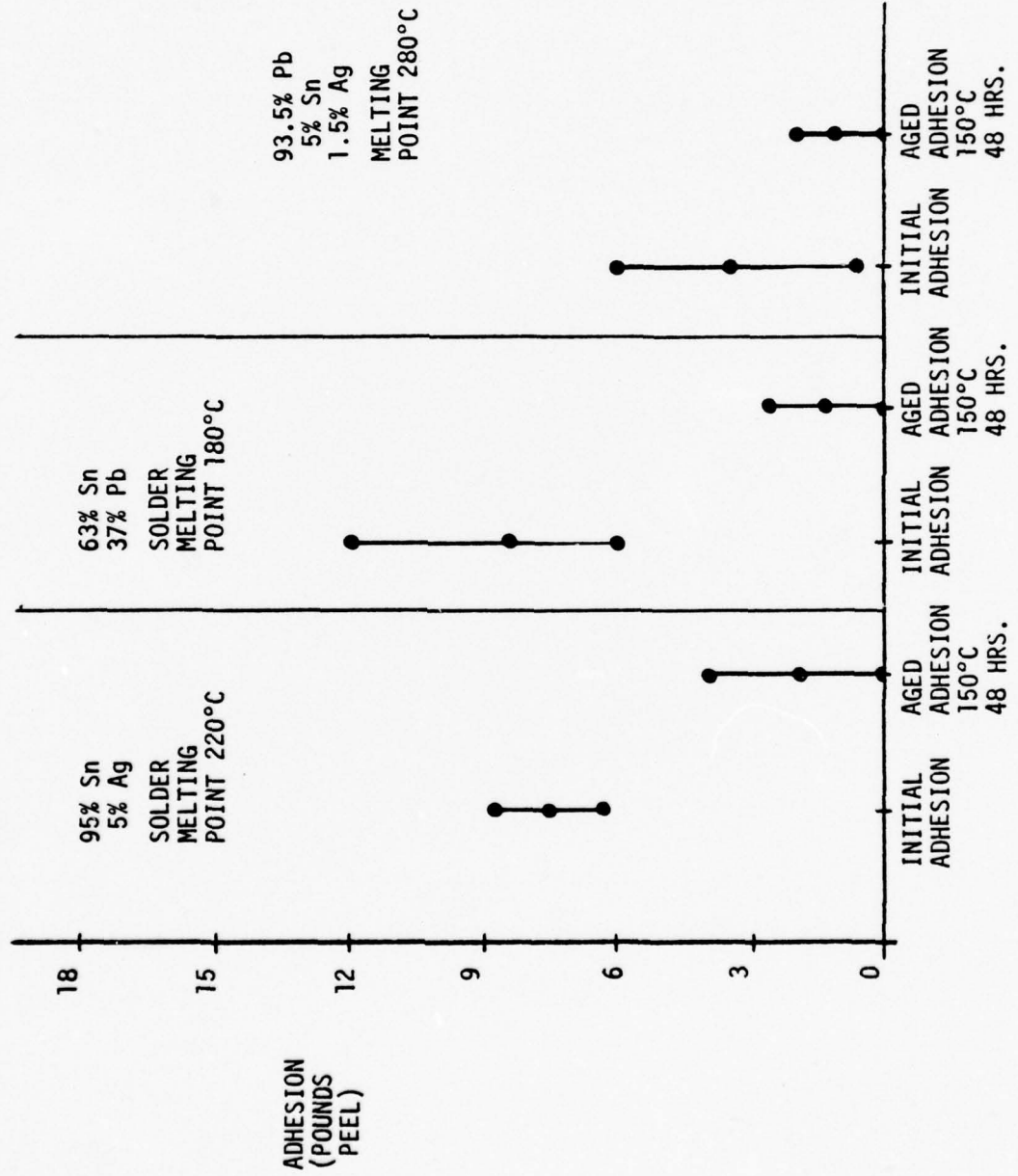

FIGURE 7-6

ADHESION OF DUPONT 9770 PtAg  
VS  
SOLDER TYPE

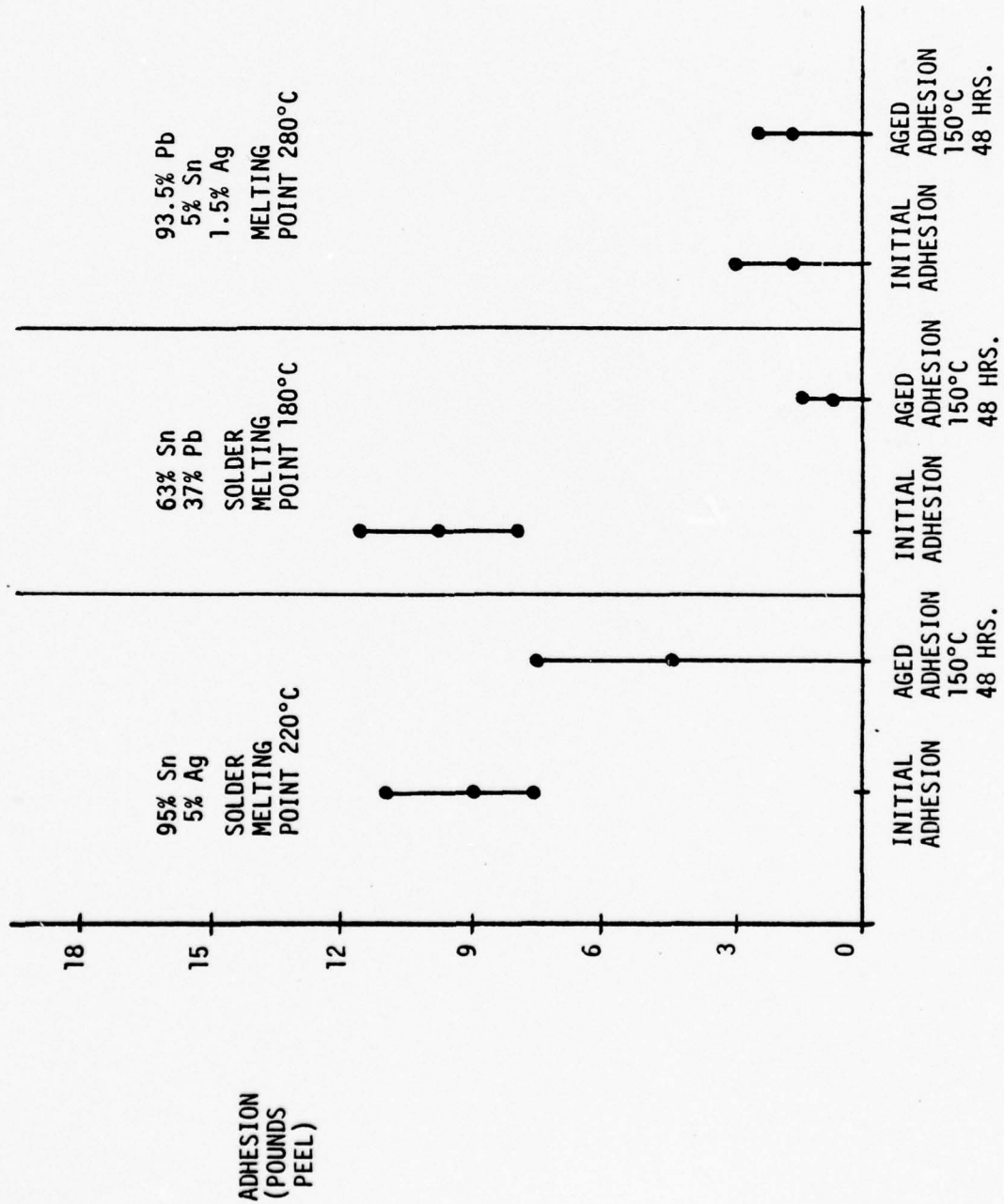
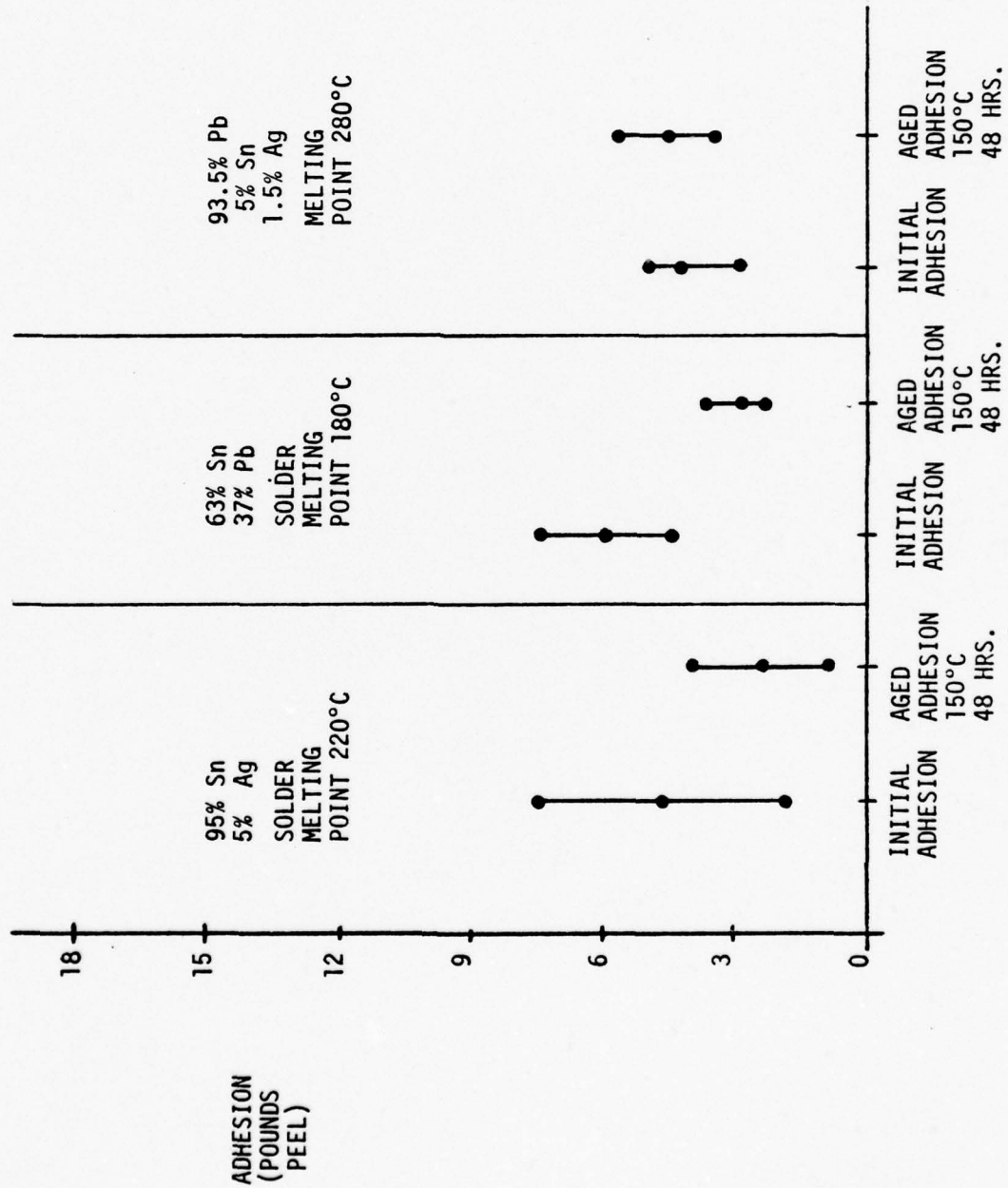

FIGURE 7-7

ADHESION OF DUPONT 9308 PdAg  
VS  
SOLDER TYPE



intermetallic compound formation between pallidum and tin with the 93.5% Pb, 5% Sn, 1.5% Ag exhibiting the highest average aged adhesion and 95% Sn, 5% Ag the lowest.

Figure 7-8 is a plot of adhesion vs solder type for Dupont 9885 PtAu. Plotted values are high, low and average adhesions. Initial adhesion appears to be dependent upon tin content of the solder. Aged adhesion did not follow the same trend but rather seemed to be more affected by the melting point of the solder. This may indicate a disruption of the bonding mechanism with higher temperature solders. Aging further disturbs the reactive products with some loss of adhesion. Dupont noted their data does not include different solders, but they felt that adhesion values were reasonable.

These two adhesion tests showed generally expected results, varying substrate type and solder type on selected thick film conductors. Dupont's 9308 PdAg showed good adhesion to 96% alumina substrates using different solders. Dupont's 9885 PtAu showed typical results for this type of material; that is, minimal loss (or in some cases increase) of adhesion during aging. PtAg and copper metallization indicated significant loss of adhesion during aging. Dupont's 9791 gold had acceptable adhesion, using AuSn solder, but should not be used with soft solders in a manufacturing environment.

FIGURE 7-8

ADHESION OF DUPONT 9885 PTAU  
VS  
SOLDER TYPE

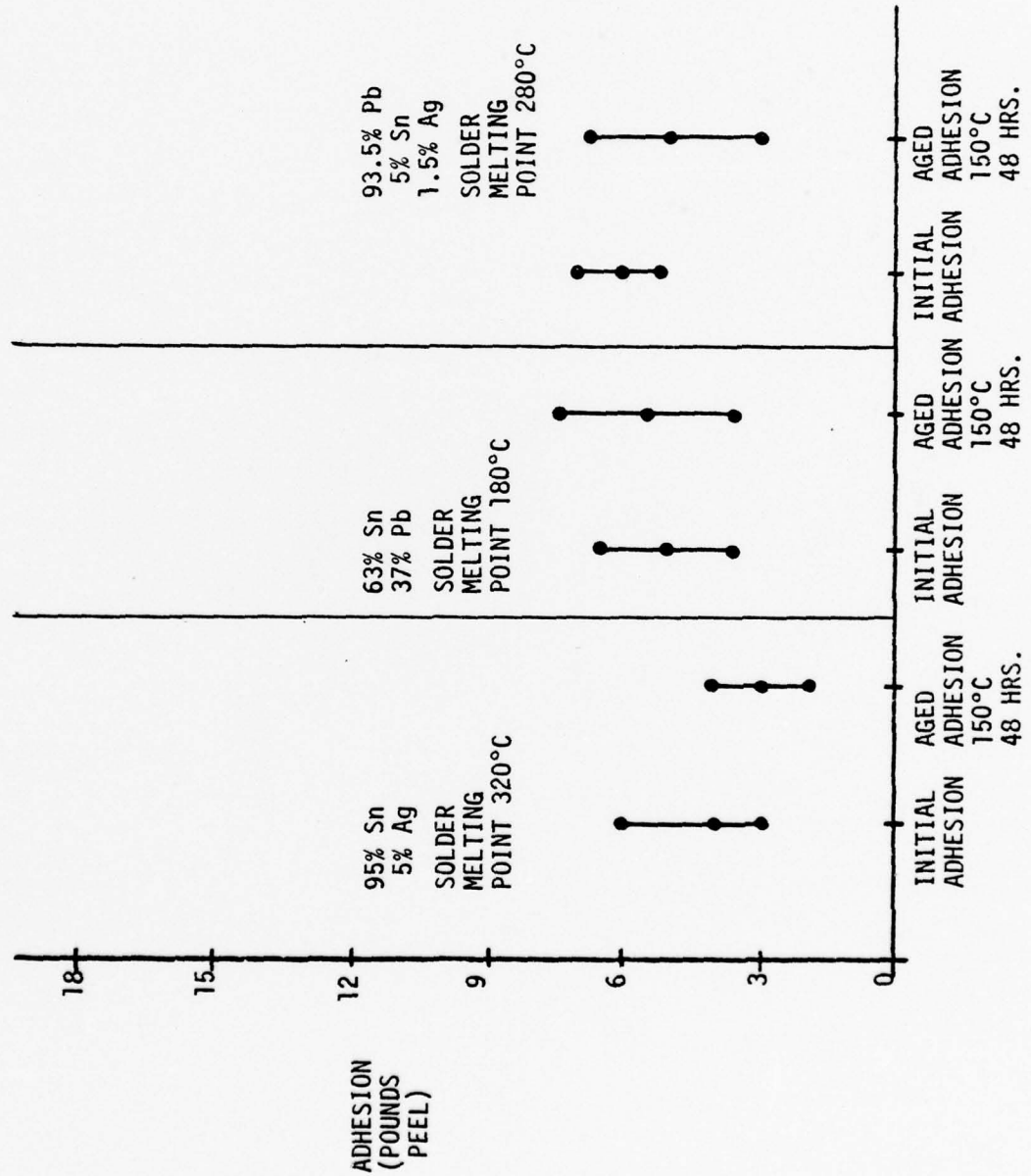

### 7.3 WIRE BONDABILITY

Samples prepared for wire bonding (gold, thermo-compression, ball bonding) were prepared as outlined in Appendix I-B. The bondability bond-strength data had little affect on the elimination or acceptance of any of the conductors. However, this data did tend to confirm some of the trends observed in the adhesion testing reported earlier. The data is presented in Table 7-4. Samples were aged at 150°C for 48 hours.

The ball lifts and metallization failures listed for Cermalloy's 7029 copper tend to confirm the material was too thin for formation of reactive products for optimum adhesion.

The metal failures of Electro-Oxide material after aging on MRC superstrates tend to indicate the firing cycle for this material was not optimized.

The other metallizations, gold PtAu and PtAg, indicate acceptable bond strengths since there were no failures in the metallization material or the wire to the film interface. All of the thick film materials were bondable and, with some firing cycle adjustment, could be made acceptable.

## BONDING CHARACTERISTICS OF THICK FILM CONDUCTORS

SUBSTRATE	METALLIZATION	CONDI- TIONING	MODE OF FAILURE						AVG. PULL
			WIRE BREAKS	HEEL	NECK	WEDGE LIFT	BALL LIFT	METAL. FAIL.	
6 - 8 $\mu$ inch	CERMALLOY 7029 Cu	INITIAL	89.3%	3.6%	3.5%	3.6%	0	0	5.76g
		AGED	83.3%	16.7%	0	0	0	0	6.70g
	ELECTRO-OXIDE 6990 Au	INITIAL	93.3%	0	6.7%	0	0	0	7.88g
		AGED	100%	0	0	0	0	0	8.54g
	DUPONT 9770 PtAg	INITIAL	90%	6.6%	3.4%	0	0	0	7.87g
		AGED	93.3%	3.3%	3.4%	0	0	0	7.85g
MRC 96% $Al_2O_3$	DUPONT 9308 PdAg	INITIAL	100%	0	0	0	0	0	6.10g
		AGED	96.7%	3.3%	0	0	0	0	7.32g
	DUPONT 9885 PtAu	INITIAL	86.7%	13.3%	0	0	0	0	8.24g
		AGED	100%	0	0	0	0	0	7.77g
	DUPONT 9791 Au	INITIAL	100%	0	0	0	0	0	6.11g
		AGED	100%	0	0	0	0	0	7.46g
MRC 99.5% $Al_2O_3$	CERMALLOY 7029 Cu	INITIAL	77.8%	11.1%	0	3.7%	3.7%	0	7.13g
		AGED	80.0%	6.7%	13.3%	0	0	0	7.24g
	ELECTRO-OXIDE 6990 Au	INITIAL	96.6%	0	3.4%	3.4%	0	0	6.86g
		AGED	72.4%	3.5%	10.3%	0	0	13.8%	8.04g
	DUPONT 9770 PtAg	INITIAL	100%	0	0	0	0	0	6.90g
		AGED	96.6%	0	3.4%	0	0	0	7.90g
	DUPONT 9308 PdAg	INITIAL	100%	0	0	0	0	0	6.78g
		AGED	96.7%	0	3.5%	0	0	0	7.71g
	DUPONT 9885 PtAu	INITIAL	100%	0	0	0	0	0	7.99g
		AGED	100%	0	0	0	0	0	7.59g
	DUPONT 9791 Au	INITIAL	100%	0	0	0	0	0	7.21g
		AGED	100%	0	0	0	0	0	7.43g
AlSiMag 614 - 96% $Al_2O_3$	CERMALLOY 7029 Cu	INITIAL	90%	3.4%	3.3%	0	3.3%	0	6.32g
		AGED	56.7%	16.7%	13.3%	0	10.0%	3.3%	6.03g
	ELECTRO-OXIDE 6990 Au	INITIAL	100%	0	0	0	0	0	6.87g
		AGED	100%	0	0	0	0	0	7.98g
	DUPONT 9770 PtAg	INITIAL	90%	3.3%	6.7%	0	0	0	6.20g
		AGED	93.3%	6.7%	0	0	0	0	7.20g
	DUPONT 9308 PdAg	INITIAL	100%	0	0	0	0	0	6.15g
		AGED	100%	0	0	0	0	0	7.22g
	DUPONT 9885 PtAu	INITIAL	90%	6.7%	3.3%	0	0	0	7.32g
		AGED	96.7%	3.3%	0	0	0	0	7.68g
	DUPONT 9791 Au	INITIAL	100%	0	0	0	0	0	6.03g
		AGED	100%	0	0	0	0	0	6.94g

#### 7.4 ELECTRICAL EVALUATION

Several types of electrical measurements were made. D.C. resistivity was measured on all conductors using a serpentine pattern with an aspect ratio of 436:1. A D.C. electrical continuity check for screened-through-holes was done to determine relationship of hole size to substrate thickness. High frequency measurements were made and a relationship of Q vs frequency established.

D. C. resistivity as a function of substrate type is shown in Table 7-5. All samples were fired with the same profile used for the adhesion tests. All resistivity values are in the range of values reported by the thick film manufacturers' data. No significant differences as a function of substrate type were observed although measurement accuracy may not have been good enough to establish significant differences between substrate type.

The feasibility, yield and reliability of screen-through-holes was investigated. Substrate thicknesses were .025, .040 and .060 inches. Laser drilled hole diameters were .020, .025, .030 and .040 inches. The procedure used for preparation of samples is outlined in Appendix I-C. Table 7-5 summarizes the initial evaluation using Dupont 9308 PdAg. (Only this material was used for this investigation.) With a hole diameter equal to or greater than the substrate thickness, screened-through-hole process can be done with high yield. Table 7-6 summarizes the results after the same samples shown in Table 7-7 are then subjected to 1000 hours at 150°C and ten temperature cycles from -55°C to +125°C. Two screened-through-holes on substrates .025 inches thick with .020 diameter holes failed during environmental conditioning. Hole diameters equal to or greater than the thickness of the substrate should produce screened-through-holes with high yield. The only requirement is proper tooling. The platen should have holes 10% smaller in diameter which are centered exactly below the substrate holes to insure the vacuum will pull the

TABLE 7-5  
 D.C. RESISTIVITY CHARACTERISTICS  
 OF THICK FILM CONDUCTORS  
 ALL MEASUREMENTS IN MILLIOHMS/SQUARE

MATERIAL		96% AlSiMag 614	96% MRC	99.5% "SUPERSTRATES"
DUPONT 9770 PtAg	$\bar{x}$ $\sigma$	3.126 .053	3.452 0.87	3.248 .015
ELECTRO-OXIDE 1130 PtAg	$\bar{x}$ $\sigma$	3.636 .038	3.986 .242	3.778 .242
DUPONT 9791 Au	$\bar{x}$ $\sigma$	2.794 .021	2.806 .038	2.882 .026
ELECTRO-OXIDE 6990 Au	$\bar{x}$ $\sigma$	3.210 .059	3.448 .078	3.298 .065
CERMALLOY 7029 Cu	$\bar{x}$ $\sigma$	2.940 .045	2.890 .122	2.820 .049
DUPONT 9308 PdAg	$\bar{x}$ $\sigma$	31.02 .62	31.22 .38	30.59 .63
DUPONT 9885 PtAu	$\bar{x}$ $\sigma$	115.40 2.43	115.78 2.43	115.28 .90

TABLE 7-6  
PLATED THROUGH HOLE CONTINUITY  
INITIAL

HOLE DIAMETER	SUBSTRATE THICKNESS (INCHES)					
	.020		.040		.060	
	SAMPLE SIZE	YIELD %	SAMPLE SIZE	YIELD %	SAMPLE SIZE	YIELD %
.020	197	98.5	176	98.9	160	5%
.025	200	100	176	100	160	27.5%
.030	200	100	176	100	160	50%
.040	200	100	176	94.9	160	35.6%

TABLE 7-7  
 PLATED THROUGH HOLE CONTINUITY  
 AGED 1000 HOURS 150°C  
 TEMPERATURE CYCLE 10 TIMES -55°C TO 125°C

HOLE DIAMETER	SUBSTRATE THICKNESS (INCHES)					
	.020		.040		.060	
	SAMPLE SIZE	YIELD %	SAMPLE SIZE	YIELD %	SAMPLE SIZE	YIELD %
.020	200	97.5	176	98.9	160	5%
.025	200	100	176	100	160	27.5%
.030	200	100	176	100	160	50%
.040	200	100	176	94.9	160	35.6%

thick film ink through the holes. The vacuum opening should be consistent with the requirement that the substrate be held tightly during printing.

High frequency measurements of the thick film metallizations were made, and the procedure for the measurements is outlined in Appendix I-D. Q measurements were made at 2, 4 and 8 GHz. For comparison, thin film gold metallization 250  $\mu$ inch thick is also presented. Figure 7-9 is a plot of Q vs frequency for the thick film conductors designed to produce a 50 $\Omega$  impedance. As expected, an inverse relationship is displayed between Q and sheet resistivity; i.e., the lower the sheet resistivity, the higher the Q. The high resistivity inks, PtAu and PdAg, had the lowest Q, while the conductive inks, gold, PtAg and copper, had the highest Q. Figure 7-10 graphically shows the relationship of Q to sheet resistivity at the three frequencies of measurement. This data is for only one firing type profile. Should optimum electrical properties be necessary at these frequencies, investigation of Q as a function of firing temperature would be necessary. Resistivity, and therefore Q, would be expected to vary as a function of firing temperature and time at temperature due to further diffusion of glass in the thick film ink for a frit system, or the additional sintering of metal particle and possible diffusion and reaction of reactive components in the thick film ink during firing.

46 4973

K·E SEMI-LOGARITHMIC #2 CYCLES X 70 DIVISIONS  
KEUFFEL & ESSER CO. MADE IN U.S.A.

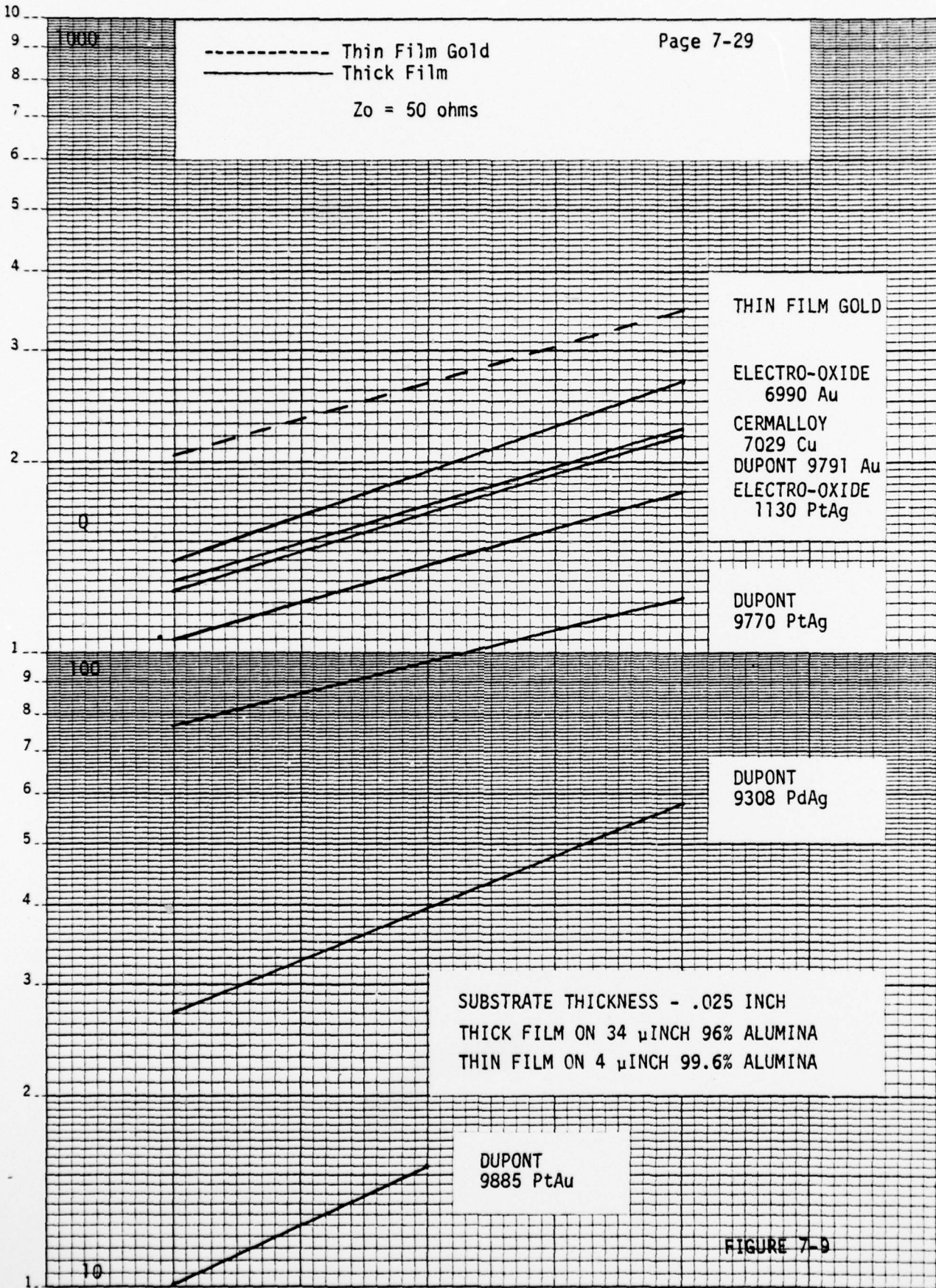

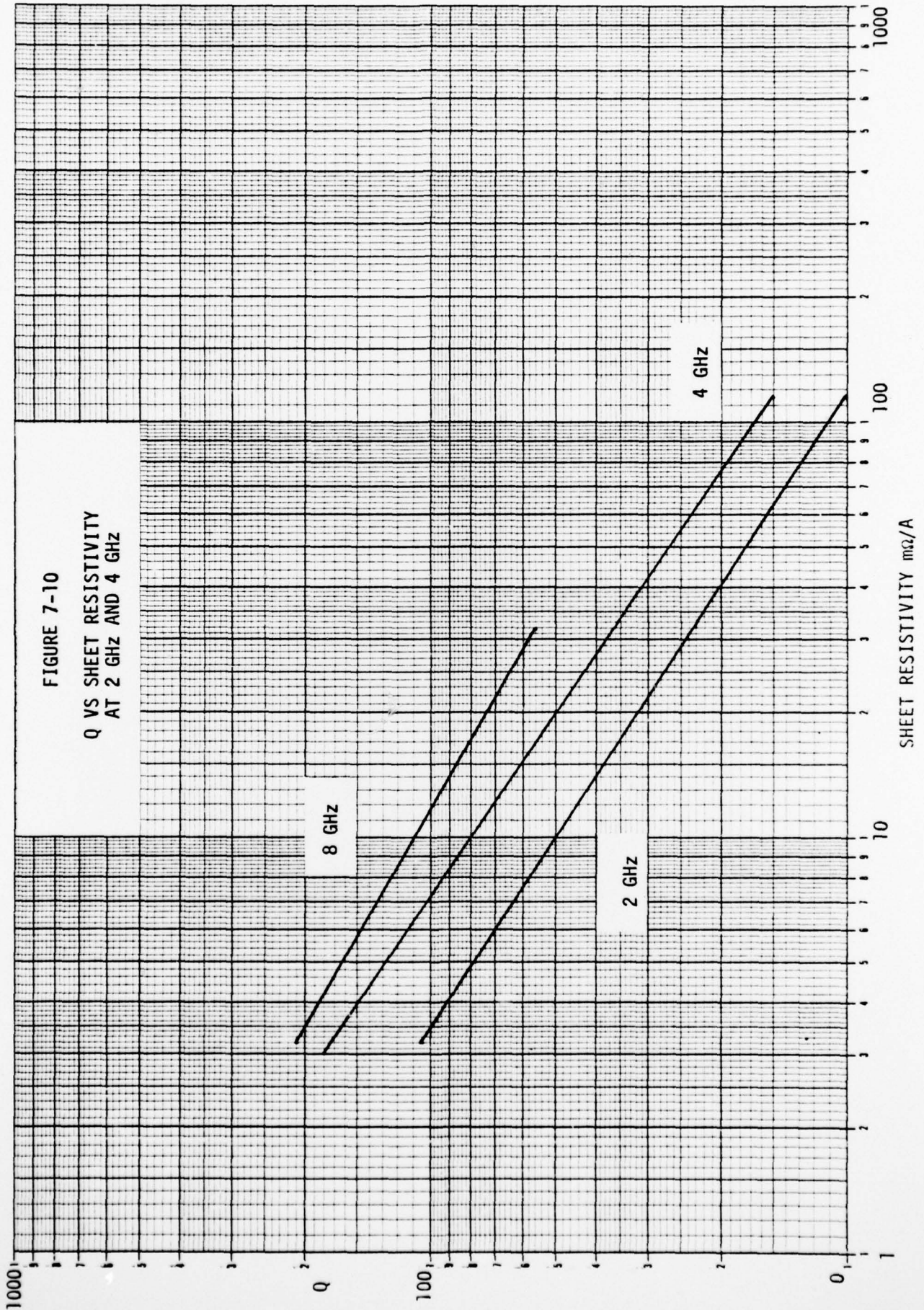

## 7.5 CONCLUSIONS

Adhesion of thick film conductors is affected by substrate type, film thickness and firing profile. To insure adequate adhesion, all three variables should be investigated and the process optimized. Adhesion, both initial and aged, must be determined to insure proper performance of circuits over operating life and temperature. The tests conducted in this investigation showed the Dupont 9308 PdAg and Dupont 9885 PtAu had satisfactory adhesion with profiles suggested by Dupont used and screening parameters chosen. Using gold bearing solders, Dupont 9791 gold had satisfactory adhesion. Further investigation of film thickness and furnace profiles is necessary to achieve maximum adhesion of thick film conductor materials.

Screened-through-hole process for ground connections is a reliable process provided hole diameters are equal to or greater than the substrate thickness. Proper platen tooling is necessary to insure the ink is pulled through the holes by vacuum.

Electrical resistivity is not affected by substrate type within the accuracy of measurement. Changes of furnace profile could produce a lower film resistivity.

Q measurements correlate well with D.C. resistivity measurements. Once again, effect of firing profile was not investigated, and Q measurement could be a more sensitive parameter to monitor than D. C. resistivity.

For the thick film conductors investigated, Dupont 9791 Au is recommended for maximum Q and satisfactory adherence; however, gold bearing solders must be used for solder attachment of passive and active components. For hybrid assemblies using soft solders, either Dupont 9308 PdAg or Dupont 9885 PtAu is recommended. Further work is required to characterize a conductor system with high Q and compatibility with soft solders.

## APPENDIX I-A

7.6 METHOD OF TEST FOR WIRE PEEL ADHESION OF SOLDERED THICK FILM CONDUCTORS TO CERAMIC SUBSTRATES1.0 SCOPE

This method of test covers a procedure for determining the bond-strength characteristics of microcircuit thick films bonded to insulating substrates.

2.0 DEFINITION

- 2.1 Breaking Strength - the average load for a specified bond area and bending distance required to separate one member from the other over the adhered surfaces. The load shall be applied in tension and perpendicular to the bond plane at a point determined by the bending distance.

3.0 APPARATUS

- 3.1 Testing Machine - a tensile testing machine which fulfills the following requirements:
- 3.1a Fixed Member - A fixed or stationary member carrying one grip.
  - 3.1b Movable Member - A movable member or crosshead carrying a second grip.
  - 3.1c Grips - Grips for holding a test specimen between the fixed and the movable member.
  - 3.1d The applied tension as measured and recorded shall be accurate to  $\pm 5\%$ .
  - 3.1e A suitable device for recording the maximum load value for each thick film.
  - 3.1f The machine should be of such capacity that the maximum applied load during test shall not exceed 85% nor be less than 15% of rated capacity. However, experimental readings will be recorded regardless of percentage of scale reading.

4.0 TEST SPECIMENS

- 4.1 The test specimens shall consist of ceramic wafers upon one surface of which a thick film to be tested has been formed to a specific shape and thickness. (See Section 5 - "Preparation of Test Specimen".)
- 4.2 The part of the test specimen for applying the loading force shall consist of the following:

Wire of a specified diameter (gauge). Recommended: 0.081 cm (0.932") dia. (AWG #20 gauge.)

- 4.3 Several test specimens shall be prepared. Each specimen is to have test pads of uniform size, square shaped and equally spaced. The thickness of the film shall be measured and recorded.

Recommended pad size: 0.20 cm X 0.20 cm (0.08" X 0.08")

## 5.0 PREPARATION OF TEST SPECIMENS

### 5.1 Materials

- 5.1a Conductor composition to be tested.
- 5.1b Screen Pattern - 200 mesh or 325 mesh.
- 5.1c Wire - #20 AWG bare wire.
- 5.1d Solder - 62 Sn/36 Pb/2 Ag
- 5.1e Solder Flux - Kester 1544 or Kester 1571
- 5.1f Substrates - As supplied per experiment.

### 5.2 Test Patterns

- 5.2a Print, dry and fire conductor test patterns as specified.
- 5.2b Handle test substrates along edges only during all phases of sample preparation.
- 5.2c Compositions to be tested should be thoroughly mixed prior to printing. Printed patterns should be uniform in appearance.

### 5.3 Wire Leads

- 5.3a Wire to be used with this test should be clean and free of tarnish to ensure good solder wetting.
- 5.3b If test wire leads are to be made from spool wound stock, all bends and kinks must be removed. This can be done by cutting a length of wire several feet long, fastening one end in a suitable stationary fixture and stretching the wire from the other end with pliers. The stretch should not exceed 0.5"/foot.
- 5.3c After straightening wire, cut 4-inch lengths, handling wire as little as possible. Carefully form crooks at one end of each wire lead and twist crooks shut to form loops. Needle-nose pliers are suitable for this purpose.
- 5.3d Degrease formed wire leads in solvent and allow to dry. After this cleaning step, handle wire leads at extreme ends only.

#### 5.4 Lead Attachment

- 5.4a Dip the substrate into solder flux to a depth of about 1/4". Allow excess to drain off.
- 5.4b Make sure the solder bath surface is free of flux residues and dross. Place flux-coated edge of substrate in contact with molten solder surface, holding substrate in a vertical position while doing so. Hold in this position for several seconds to allow heating of flux. When flux shows evidence of wicking up the substrate, lower the substrate into bath until all adhesion test pads are fully immersed.
- 5.4c Solder immersion time should be sufficient to ensure complete wetting of the test pads. Adequate immersion periods will depend upon type of material to be tested and may have to be determined prior to preparation of adhesion test samples. Immersion periods should be no longer than necessary to prevent excessive leaching of test material. Consult the manufacturer for specific soldering schedules.
- 5.4d Withdraw the immersed test patterns from the solder bath at a uniform rate to allow draining of excess solder. A withdrawal rate of 0.5-1.0"/sec. is appropriate in most cases. Do not attempt to force cool the solder bonds by means of a cool air draft or blowing upon them.
- 5.4e Using soldering iron set to temperature for reflowing solder and pre-heated hot plate (115°C), solder leads onto center of pads. More flux may be used.
- 5.4f When the substrate has cooled to a safe-to-touch temperature, rinse with solvent to remove flux residue and allow to air dry.

#### 5.5 Sample Curing

Allow a minimum 16-hour room temperature curing period prior to performing adhesion measurements. During this period, the solder system will have approached a sufficient degree of structural equilibrium to permit best reproducibility during testing.

#### 5.6 Lead Wire Bending

- 5.6a Carefully place a straight edged rule across the lead wires and bend .050" from edge of test pattern. The peeling force is very dependent upon the length of wire between the bend point and the pad edge. Exercise care in making wire bends at a uniform distance from the pads.

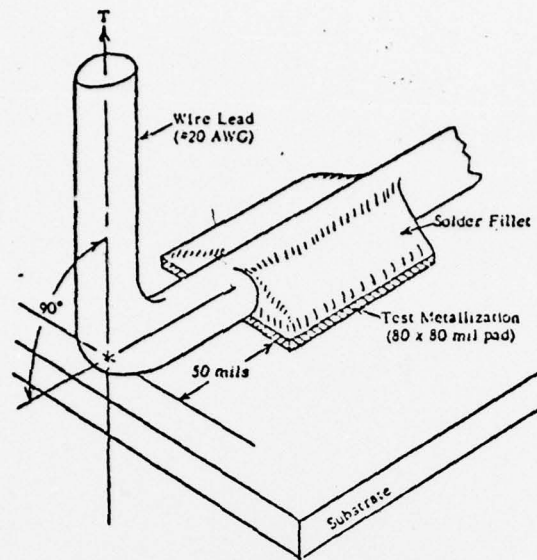

ADHESION TEST BOND CONFIGURATION

- 5.6b Bend each wire to a perpendicular with the substrate surface and mount onto the test instrument, being careful to maintain perpendicularity between wire and substrate. It may be necessary to bend each lead wire immediately prior to testing the associated pad to prevent interference from adjacent lead wires during clamping.

## 6.0 MEASUREMENT PROCEDURE

- 6.1 Measure each bond-strength as pulled and record the data.

## 7.0 DATA RECORDING

In addition to a description of pertinent sample processing conditions and materials used, the following items should appear on the test report:

- 7.1 Individual pad breaking strengths in instrument measurement dimensions (lbs or grams). In general, the recorded values should be precise to within 1% of instrument full-scale (e.g., 0.1 lb for a 10-lb scale). Each recorded value should be easily identifiable as to substrate and material.
- 7.2 Bond failure mode for each test pad. The following notation should be adequate and appropriate entry made next to each recorded breaking strength.

<u>Failure Mode</u>	<u>Description</u>
A	Separation of metallizing from substrate. Small amounts of metallizing may remain in isolated pad areas.
B	Separation occurs within the solder fillet, leaving metallizer pad essentially intact. A plane of separation close to the pad surface is usually apparent.
C	Separation occurs between lead wire and solder fillet. Partial removal of metallizer and fillet may also occur.

- 7.3 Calculate and record the average breaking strength ( $\bar{X}$ ), standard deviation ( $\sigma$ ), the coefficient of variation (CV) and the number of pad samples tested (n). The following formulae should be used:

Average Breaking Strength:

$$\bar{X} = \frac{X_1 + X_2 + \dots + X_n}{n} \quad (1b)$$

Standard Deviation:

$$\sigma = \frac{\sqrt{\sum (X_i - \bar{X})^2}}{\sqrt{n}} \quad (1b)$$

Coefficient of Variation:

$$CV = \frac{100\sigma}{\bar{X}} \quad (\%)$$

## APPENDIX I-B

7.7 BONDABILITY TESTS FOR THICK FILM METALLIZATIONS

The following procedure outlines minimum tests to ensure bondability of thick film materials. Note that a bonding process with 99.9% confidence results in a circuit yield of about 82% if the circuit contains 100 intraconnections.

Sample Preparation - Cleaning

1. 5 - 10 minute wash in A20 Stripper \*
2. Hot water rinse
3. Isopropyl alcohol rinse
4. Blow dry with N<sub>2</sub>

Materials and Equipment

1. Gold Wire
  - A. 1.0 mil dia., CPN 431-0668-070
  - B. 0.7 mil dia., CPN 431-0668-100
2. Collins C500A bonders equipped with beryllium oxide capillaries

Machine Setup

The C500a bonder is set up according to standard procedure.

Bonding Procedure

Bonding is performed according to standard procedure. Basic parameters are as follows:

1. 1.0 mil wire
  - A. 90 grams force, ball bond
  - B. 1.0 - 1.2 seconds dwell, ball bond
  - C. 220 ± 10°C work temperature
  - D. 600 ± 15°C capillary temperature
  - E. 50 grams force, wedge bond
  - F. Minimum dwell, wedge bond
2. 0.7 mil wire
  - A. 55 grams force, ball bond
  - B. 1.0 - 1.2 seconds dwell, ball bond
  - C. 220 ± 10°C work temperature
  - D. 600 ± 15°C capillary temperature
  - E. 35 grams force, wedge bond
  - F. Minimum dwell, wedge bond

Sample Size Per Material Combination

Material combination includes:

1. Wire size
2. Metallization composition
3. Metallization process conditions
4. Substrate
5. Underlying metallizations or classifications

\* Allied Chemical Chlorinated Phenol Solvent

Minimum sample size is twenty wires per test. This at most yields a 95% confidence in bondability.

### Tests

1. As Bonded Conditions
  - A. Visual inspect to requirements of MPM 768-4080-001
  - B. Destructively pull test using the hook technique mil std. 883A, method 2011.1, condition D
  - C. Record breaking strength in grams and failure mode. For definitions of failure modes see Figure 1.
2. Stressed by Aging and Temperature Cycling
  - A. Age for 48 hours at 150°C
  - B. Temperature cycle (10 cycles) per mil std. 883A, method 1010.1, condition C
  - C. Destructively pull test using hook technique mil std. 883A, method 2011.1, condition D
  - D. Record breaking strength in grams and failure mode

### Definitions of Failure modes

Figure 1.

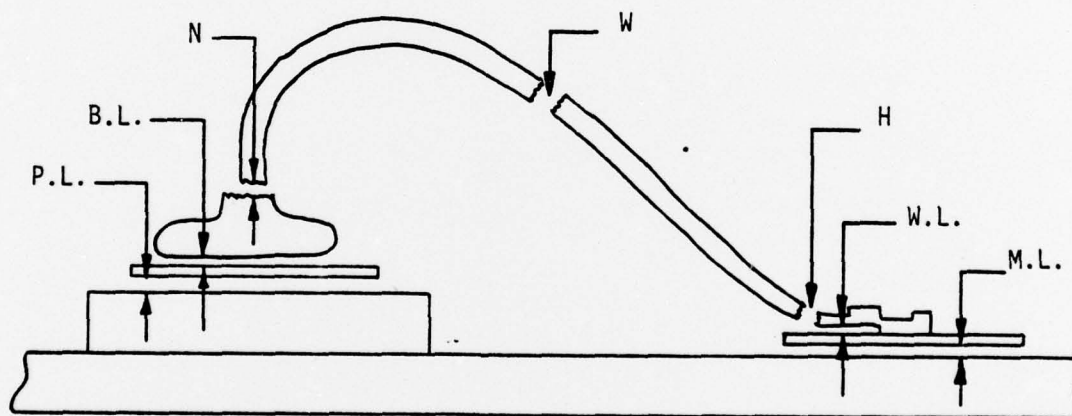

P.L. - Bond Pad Lift  
 B.L. - Ball Lift  
 N. - At Neck Down Above Ball  
 W. - Wire Failed

H. - Heel of Wedge  
 W.L. - Wedge Lift  
 M.L. - Metallization Lift  
 O. - Other Modes

Disposition of Material

1. Bondability - Good

This condition is met if after testing all wires met the strength requirements of mil std. 883A, method 2011.1, condition D and all failures occurred in the wire.

2. Bondability - Questionable

This condition is met if after testing all wires met the strength requirements of mil std. 883A, method 2011.1, condition D, but at least one wire failed as a ball or wedge lift.

3. Poor Bondability

This condition is met if minimum strength is less than that required by mil std. 883A, method 2011.1, condition D and failures of ball lifts and wedge lifts occur.

7.8

## APPENDIX I-C

1.0 SCOPE

To determine the feasibility and, if feasible, the methods of screening thru holes in three different thickness ceramics.

2.0 MATERIALS

2.1 Dupont 9308 PdAg                      T = 850°C

## 2.2 Drilled Matrices

2.2a 20-each .025" thick ceramics

2.2b 20-each .040" thick ceramics

2.2c 20-each .060" thick ceramics

} Hole Sizes Defined in Text

## 2.3 Drilled Platen

3.0 PROCEDURE:

3.1 Using a 200 mesh test pattern, screen conductors on one side of ceramic.

3.2 Dry - Fire at recommended temperature.

3.3 Print backside of ceramic using same screening pattern.

3.4 Dry - Fire at recommended temperature.

3.5 Measure integrity of holes as to conductivity, cosmetic appearance.

3.6 Calculate yield as substrate thickness vs hole diameter.

3.7 Age the parts for 1000 hours at 150°C; then, temperature cycle ten times from -55°C to +125°C

3.8 Repeat steps 5 and 6.