

Report No. 5040-27 (Change 1)

CG-D-11-77
July 1977

AD A 0 4 7 9 2 5

COMPUTER PROGRAM FOR
DESIGN AND PERFORMANCE ANALYSIS
OF NAVIGATION-AID POWER SYSTEMS

12
JR

Program Documentation
Volume I
Software Requirements Document



July 1977

Final Report

DDC
RECEIVED
DEC 29 1977
B

Prepared for

**DEPARTMENT OF TRANSPORTATION
UNITED STATES COAST GUARD**

Office of Research and Development
Washington, D.C. 20590

DDG FILE COPY

DISTRIBUTION STATEMENT A
Approved for public release
Distribution Unlimited

DISCLAIMER NOTICE

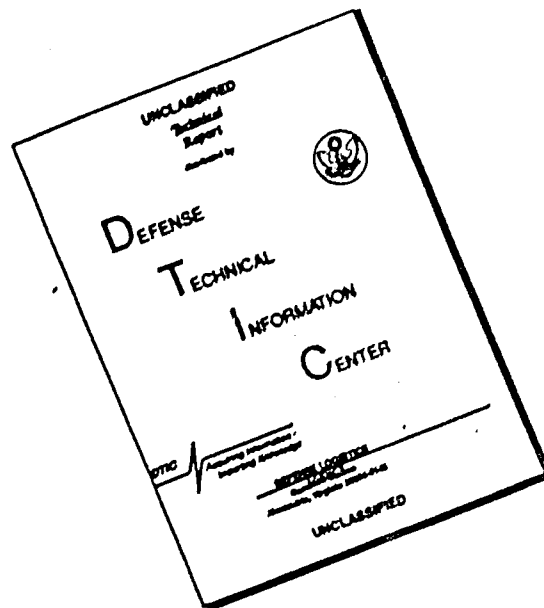

THIS DOCUMENT IS BEST QUALITY AVAILABLE. THE COPY FURNISHED TO DTIC CONTAINED A SIGNIFICANT NUMBER OF PAGES WHICH DO NOT REPRODUCE LEGIBLY.

N O T I C E

This document is disseminated under the sponsorship of the Department of Transportation in the interest of information exchange. The United States Government assumes no liability for its contents or use thereof.

The United States Government does not endorse products or manufacturers. Trade or manufacturers' names appear herein solely because they are considered essential to the object of this report.

The contents of this report reflect the views of the Jet Propulsion Laboratory, which is responsible for the facts and accuracy of data presented. This report does not constitute a standard, specification or regulation.

D. L. Birkimer

DONALD L. BIRKIMER, Ph.D., P.E.
Technical Director
U.S. Coast Guard Research and Development Center
Avery Point, Groton, Connecticut 06340

1. Report No. CG-D-11-77		2. Government Accession No.		3. Recipient's Catalog No.	
4. Title and Subtitle COMPUTER PROGRAM FOR DESIGN AND PERFORMANCE ANALYSIS OF NAVIGATION-AID POWER SYSTEMS. Program Documentation, Volume I: Software Requirements Document.				5. Report Date Jul 1977	
6. Author(s) G./Goltz, L.M./Kaiser, H./Weiner				7. Performing Organization Code 12 182 P.	
8. Performing Organization Name and Address Jet Propulsion Laboratory 4800 Oak Grove Drive Pasadena, California 91103				8. Performing Organization Report No. JPL [redacted] -5040-27	
9. Sponsoring Agency Name and Address Department of Transportation U.S. Coast Guard Office of Research and Development Washington, D.C. 20590				10. Work Unit No. (TRAIS)	
11. Contract or Grant No. MIPR No. Z-70099-5-50352				11. Contract or Grant No.	
12. Sponsoring Agency Code				12. Type of Report and Period Covered Final Report.	
13. Supplementary Notes The contract under which this report was prepared was under the technical supervision of the Coast Guard Research and Development Center, Groton, Connecticut, 06340. R&D Center Report 18/76 number has been assigned.					
14. Abstract The Jet Propulsion Laboratory has developed a computer program for designing and analyzing the performance of solar array/battery power systems for the U.S. Coast Guard Navigational Aids. This program is called the Design Synthesis/Performance Analysis (DSPA) Computer Program. The basic function of the Design Synthesis portion of the DSPA program is to evaluate functional and economic criteria to provide specifications for viable solar array/battery power systems. The basic function of the Performance Analysis portion of the DSPA program is to simulate the operation of solar array/battery power systems under specific loads and environmental conditions. This document establishes the software requirements for the DSPA computer program, discusses the processing that occurs within the program, and defines the necessary interfaces for operation.					
15. Key Words Batteries, Computer Programs, Navigation Aids, Power Systems, Solar Arrays, Solar Insolation, Statistical Analysis, Temperature, Terrestrial Power Systems, Weather, Wind Velocity		16. Distribution Statement This document is available to the U.S. public through the National Technical Information Service, Springfield, Virginia 22161			
17. Security Class. (of this report) Unclassified		18. Security Class. (of this page) Unclassified		19. No. of Pages 182	
20. Price 191 150		21. Price			

METRIC CONVERSION FACTORS

Approximate Conversions to Metric Measures		Approximate Conversions from Metric Measures		
Symbol	When You Know	Multiply by	To Find	Symbol
LENGTH				
in	inches	2.5	centimeters	cm
ft	feet	30	centimeters	cm
yd	yards	0.9	meters	m
mi	miles	1.6	kilometers	km
AREA				
sq in	square inches	6.5	square centimeters	cm ²
sq ft	square feet	0.09	square meters	m ²
sq yd	square yards	0.8	square meters	m ²
sq mi	square miles	2.6	square kilometers	km ²
	acres	0.4	hectares	ha
MASS (weight)				
oz	ounces	28	grams	g
lb	pounds	0.45	kilograms	kg
	short tons (2000 lb)	0.9	tonnes	t
VOLUME				
tsp	teaspoons	5	milliliters	ml
fl oz	fluid ounces	15	milliliters	ml
c	cups	0.24	liters	l
pt	pints	0.47	liters	l
qt	quarts	0.75	liters	l
gal	gallons	3.8	liters	l
cu ft	cubic feet	0.03	cubic meters	m ³
cu yd	cubic yards	0.76	cubic meters	m ³
TEMPERATURE (exact)				
°F	Fahrenheit temperature	5/9 (After subtracting 32)	Celsius temperature	°C
°C	Celsius temperature	9/5 (then add 32)	Fahrenheit temperature	°F

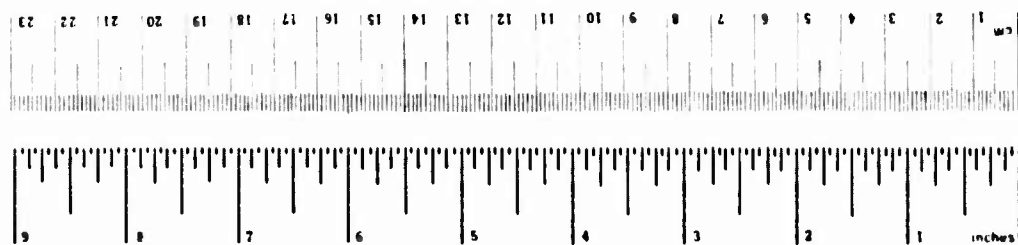

Symbol	When You Know	Multiply by	To Find	Symbol
LENGTH				
mm	millimeters	0.04	inches	in
cm	centimeters	0.4	inches	in
m	meters	3.3	feet	ft
m	meters	1.1	yards	yd
km	kilometers	0.6	miles	mi
AREA				
cm ²	square centimeters	0.16	square inches	in ²
m ²	square meters	1.2	square yards	yd ²
km ²	square kilometers	0.4	square miles	mi ²
ha	hectares (10,000 m ²)	2.5	acres	ac
MASS (weight)				
g	grams	0.035	ounces	oz
kg	kilograms	2.2	pounds	lb
t	tonnes (1000 kg)	1.1	short tons	st
VOLUME				
ml	milliliters	0.03	fluid ounces	fl oz
l	liters	2.1	pints	pt
l	liters	1.06	quarts	qt
l	liters	0.26	gallons	gal
m ³	cubic meters	35	cubic feet	ft ³
m ³	cubic meters	1.3	cubic yards	yd ³
TEMPERATURE (exact)				
°C	Celsius temperature	9/5 (then add 32)	Fahrenheit temperature	°F

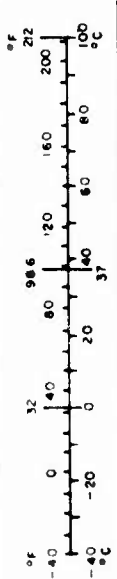

© 1992 McGraw-Hill, Inc. All rights reserved. This publication is a registered trademark of McGraw-Hill, Inc. in the United States and other countries. Printed in the United States of America. ISBN 0-07-051111-1.

TABLE OF CONTENTS

<u>SECTION</u>	<u>PAGE</u>
1. INTRODUCTION	1-1
2. PROGRAM OVERVIEW	2-1
3. DESIGN SYNTHESIS	3-1
3.1 Terminator Characteristics	3-54
3.2 Clear Day Solar Insolation	3-57
3.3 Solar Array Electrical Characteristics	3-62
3.4 Power Conditioning and Distribution Group	3-71
4. PERFORMANCE ANALYSIS	4-1
4.1 Power Sources Group	4-18
4.1.1 Shunt Limiters	4-48
4.2 Energy Storage Group	4-58
4.3 Power Conditioning and Distribution Group	4-68
5. MERGE	5-1
5.1 Creation of a MERGE File (TDF14)	5-1
5.2 Addition of Solar Insolation Data to MERGE File (DECK280).	5-2
5.3 Displaying MERGE File Data (LISTMERGE)	5-3
6. STAT	6-1
6.1 Statistical Analysis of MERGE Data (STATS)	6-1
6.2 Environmental Profiling of STATS Data (PROFILE)	6-8
FIGURES: 2-1 Design Synthesis Performance Analysis Computer Program	2-2
3-1 Power System Design Synthesis	3-2
4-1 Power System Performance Analysis	4-2
5-1 MERGE Computer Programs Overview	5-1
5-2 TDF14 Computer Program	5-2
5-3 DECK280 Computer Program	5-3
5-4 LISTMERGE Computer Program	5-4

N for	
White Section	<input checked="" type="checkbox"/>
Buff Section	<input type="checkbox"/>
NCED	<input type="checkbox"/>
TION	

BY		
DISTRIBUTION/AVAILABILITY CODES		
Dist.	AvAIL.	and/or SPECIAL
A		

TABLE OF CONTENTS (contd)

	<u>PAGE</u>
FIGURES: 6-1 STAT Computer Programs Overview	6-1
(contd) 6-2 STATS Computer Program	6-3
6-3 PROFILE Computer Program	6-8

1. INTRODUCTION

The Jet Propulsion Laboratory (JPL) has developed a computer program for designing and analyzing the performance of solar array/battery power systems for the U.S. Coast Guard Navigational Aids. This program is called the Design Synthesis/Performance Analysis (DSPA) Computer Program. The basic function of the Design Synthesis portion of the DSPA program is to evaluate functional and economic criteria to provide specifications for viable solar array/battery power systems. The basic function of the Performance Analysis portion of the DSPA program is to simulate the operation of solar array/battery power systems under specific loads and environmental conditions.

This document establishes the software requirements for the DSPA computer program, discusses the processing that occurs within the program, and defines the necessary interfaces for operation.

2. PROGRAM OVERVIEW

The DSPA computer program combines the elements of design synthesis and performance analysis. A functional block diagram of the main driver program is shown in Figure 2-1. As shown in this figure and the algorithms which follow, the DSPA computer program utilizes the following methodology.

- a. The program user selects the desired power system arrangement.
- b. If a design synthesis is not required, then the program user must provide information on the electrical size of the equipment.
- c. If a design synthesis is requested, the program user must supply information on the parameters used in determining the various profiles. The computer program then calculates the load and environmental profiles needed for a local profile analysis. Based on a profile energy balance determined as part of the load profile analysis, the computer estimates the electrical size of the equipment required and then determines the physical characteristics of the selected equipment. The calculated data along with significant input data is printed out in the appropriate output data format.
- d. If performance analysis is not required, the execution of the DSPA program is terminated.
- e. If performance analysis is required, the program user must provide information on the parameters used in determining the various profiles. The computer program then calculates the values of the load and environment at the start of the selected mission period. These stimuli (load and environment) are used to calculate the response (operational characteristics) of the equipment at that point in time. The process is repeated for selected time increments until the power system operational characteristics for the entire mission period have been determined. This information is then printed in the appropriate output data formats, and execution of the program is terminated.

Flow charts of the DSPA subprograms were not furnished in the Program Documentation volumes since:

- Most computer facilities have programs which automatically produce subroutine flow charts. If such charts are desired, the program user can easily select the subroutine of interest and obtain a copy of the latest version of the subroutine.
- Preparation, reproduction, and inclusion of all of the present versions of the DSPA subroutines in the Program Documentation would be more costly than if the flow charts were prepared by the program user automatically. Additionally, these flow charts would become obsolete as modifications were made to the DSPA computer program.

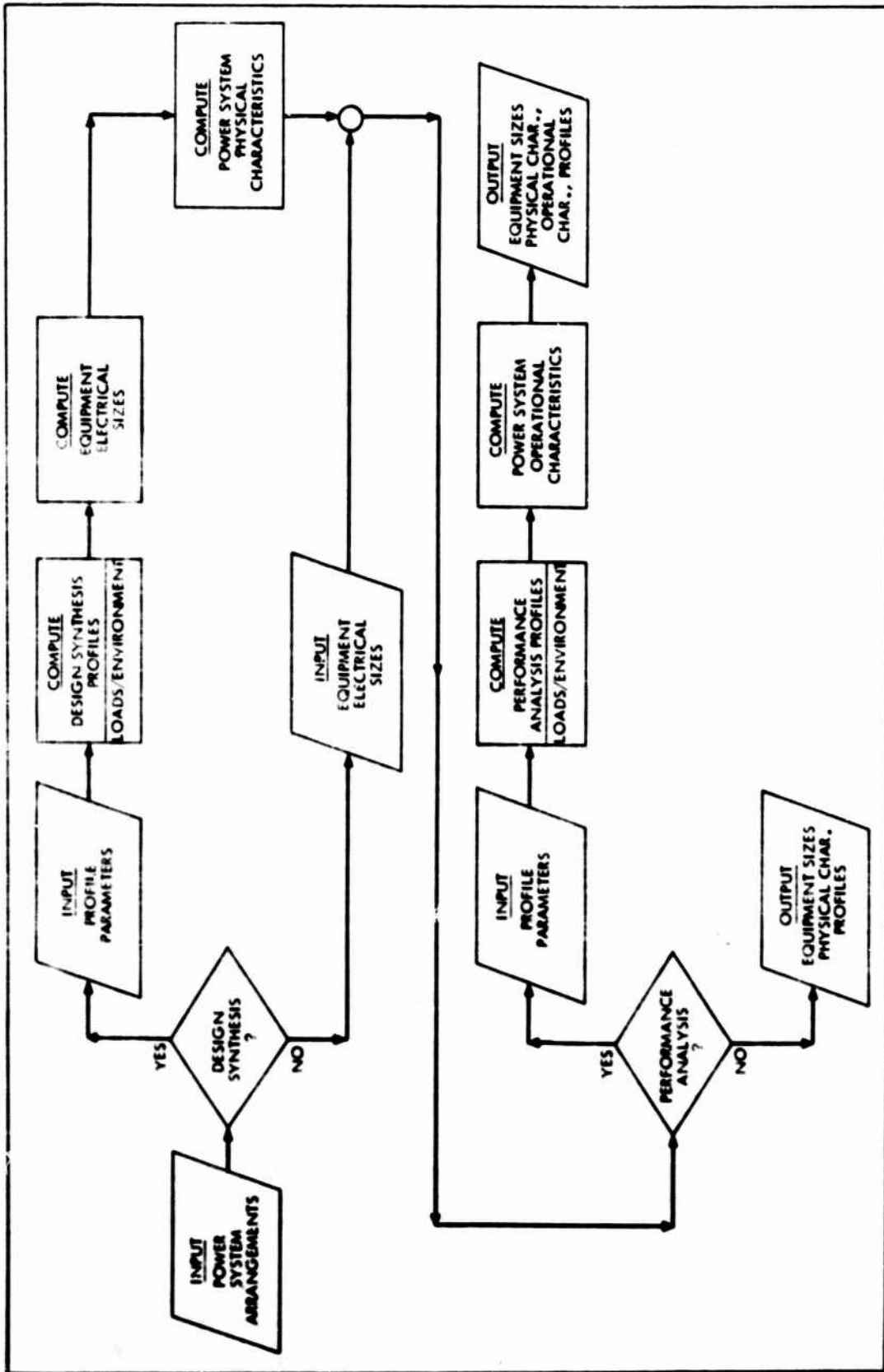

FIGURE 2-1. DESIGN SYNTHESIS PERFORMANCE ANALYSIS COMPUTER PROGRAM

PROGRAM ALGORITHMS

Step 1 Obtain Program Parameters

IPRG = Program Selector:

0 = Design Synthesis only

1 = Performance Analysis only

2 = Both Design Synthesis and Performance Analysis

ITAPE = Weather Data Input Selector:

-1 = Statistical Input Tape

0 = User Input Data

YYDDD = Merge Tape Input beginning at year = YY and
day = DDD

DEBUG = Debug Printout Request Flag:

0 = No printout

1 = Printout

XLN = Length of X-axis (in inches) for summary plots

YLN = Length of Y-axis (in inches) for summary plots

Step 2 Execute Design Synthesis program if requestedIf: IPRG \neq 1
Then: Call DS DRV RStep 3 Execute Performance Analysis program if requestedIf: IPRG \neq 0
Then: Call PA DRV RStep 4 STOP DS/PA

3. DESIGN SYNTHESIS

The Design Synthesis portion of the DSPA program uses load and environmental profiles to set the power system requirements. Based on these requirements and on the electrical characteristics of the system equipment, the computer program determines the electrical size (volts, amperes, watts, ampere-hours, watt-hours) and the physical characteristics (weight, area, cost) of the power system. A functional block diagram of the Design Synthesis driver program is shown in Figure 3-1. As shown, the selection of lamp and flasher combinations as well as the day/night load durations enables the computer program to estimate a power load profile. This profile, after modification using battery charge-efficiency and a number of power system cabling and diode losses, is used in the load profile analysis. The object of the load profile analysis is to determine the electrical size of a balanced* power source as well as the minimum theoretical electrical size of the battery. Once this information is obtained, it is a fairly straight forward process to determine the electrical size of the remaining items of equipment.

* **Balanced power source:** a power source which provides just enough energy to the batteries (during recharge periods) to offset or balance the energy loss sustained during discharge periods.

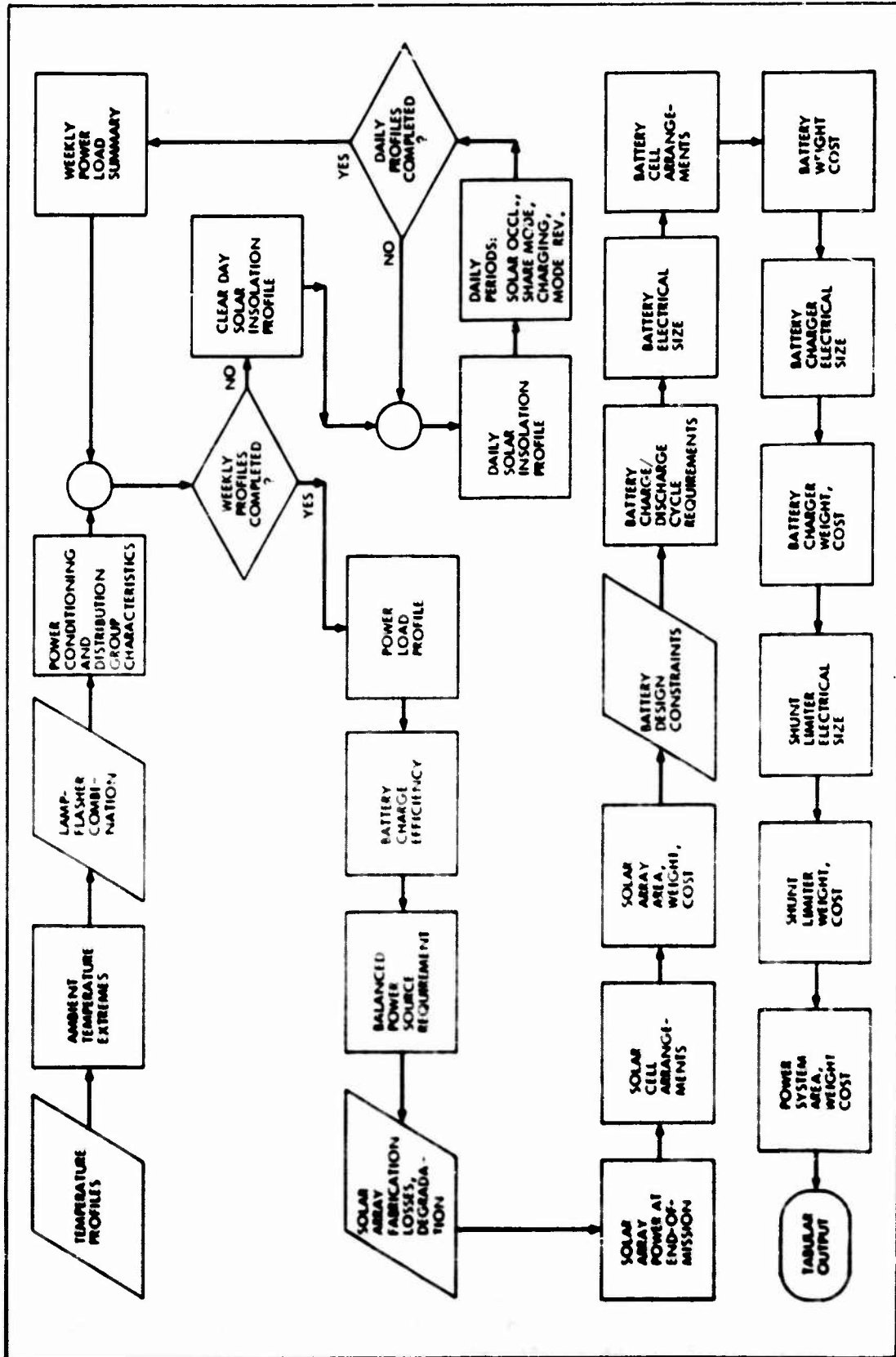

FIGURE 3-1. POWER SYSTEM DESIGN SYNTHESIS

PROGRAM ALGORITHMS

Step 1 Obtain Pertinent Mission and Equipment Information

QON = Solar Insolation Level for Lamp Flasher
Turn-On - Watts/Meter²

QOFF = Solar Insolation Level for Lamp Flasher
Turn-Off - Watts/Meter²

VBUS = Nominal value of Raw Power Bus Operating level -
VDC

VBUSMN = Minimum allowable Raw Power Bus Operating
voltage - VDC

TTAVE = Average yearly temperature in location selected -
°F

INDFLS = Lamp Flasher Condition Indicator

Where: 0 = Lamp Flasher is Off (Lamp Not Flashing)

1 = Lamp Flasher is On (Lamp Flashing)

DTESG = Energy Storage Group Temperature Rise - °F

QBRES = Battery Reserve (as Stage-of-Charge)

BRCEST = Estimated Normalized Battery Charge Current -
Hours⁻¹

BRDEST = Estimated Normalized Battery Discharge
Current - Hours⁻¹

ICHRT = Battery Charger Type

Where: 0 = No Battery Charger

1 = Constant Voltage Charger with Current
Limit

DTTPSG = Power Source Group Equipment Temperature Rise - °F

DURAM = Duration of Mission - Years

SARES = Solar Array Reserve (as a fraction of total area)

NPREQ = Number of Solar Cells in Parallel Required for
each Solar Cell Array Electrical Section

CELPAC = Solar Cell Packing Factor on Solar Array

NSAP = Total Number of Solar Arrays to be Procured

BRCHMX = Maximum Allowable Normalized Battery Charge
Current - Hours⁻¹

ISH = Shunt Limiter Type

0 = No Shunt Limiter

1 = Ordinary Zener Diode

2 = Temperature-Compensated Zener Diode

3 = Active Shunt Limiter

FRCELL = Biasing Factor for Selecting the Number of Storage
Cells in Series in the Battery

(0.0 ≤ FRCELL ≤ 1.0)

as: FRCELL → 0.0 the minimum number of cells
tend to be selected

as: FRCELL → 1.0 the maximum number of cells
tend to be selected

BRDSTD = Standard Normalized Battery Discharge
Current - Hours⁻¹

TBDSTD = Standard Battery Discharge Temperature - °F

CBAVAL(JB) = Table of Available Storage Cell Capacities, from a
Given Manufacturer, in increasing order of
size - Amp-Hours/Cell

(JB = 1,30 maximum)

CBMAX = Maximum desired capacity of each battery -
Amp-Hours

HDZMX = Maximum Heat Dissipation of a Single Zener
Diode - Watts

HDER = Heat Dissipation Derating Factor for a Single
Zener Diode

ACELL = Single Solar Cell Area - cm²

Step 1a Compare Raw Power Bus Voltage with Allowable Minimum

If: $VBUS < VBUSMN$,

Then: $VBUS = VBUSMN + 4.0$, and,

Then: Print out the following statement:

"VBUS ADJUSTED TO (... VBUS ...) VOLTS"

Step 1b Obtain Yearly Temperature Extremes

If: $ITAPE = 0$

Then: GO TO STEP 2

If: $ITAPE \neq 0$

Then: Obtain TTABMX and TTABMN from 'MERGE' File, and,

Then: GO TO STEP 5

Where: TTABMX = Maximum Value of the Ambient Temperature -
°F

TTABMN = Minimum Value of the Ambient Temperature -
°F

Step 2 Calculate Daily Temperature Increment Extremes

$DTTA = DTTA1 \{DATE\}$

DTTAMX = Maximum Value of DTTA over the range:

DATE = 1;365 days

DTTAMN = Minimum Value of DTTA over the range:

DATE = 1;365 days

Where: DTTA = Average Daily Temperature Increment - °F

DATE = Days from start of the year - days (1-365)

DTTA1 = Input table of DTTA as a function of DATE

Step 3 Calculate Hourly Temperature Increment Extremes

$DTTAMB = DTTAMB1 \{TIMEH\}$

DTTAMX = Maximum Value of DTTAMB over the range:

TIMEH = 0;24 hours

Step 3 (contd)

DTABMN = Minimum Value of DTTAMB over the range:
 TIMEH = 0;24 hours

Where: DTTAMB = Average Hourly Temperature Increment - °F

TIMEH = Daily Time - Hours after Midnight (0-24)

DTAMB1 = Input Table of DTTAMB as a function of TIMEH

Step 4 Calculate Ambient Temperature Extremes

TTABMX = TTAVE + DTTAMX + DTABMX

TTABMN = TTAVE + DTTAMN + DTABMN

Step 5 Obtain Power Conditioning and Distribution Group (PCDG) Characteristics at the Raw Power Bus

(Based on ambient temperature extreme which will yield the largest values of PCD Group Current)

XX(J,K) = Power Conditioning and Distribution Group Voltage - VDC

XI(J,K) = Power Conditioning and Distribution Group Current at XX(J,K) - Amperes

J = 1,51 (Number of Data Points)

K = PCD Group Load Selector

1 = Lamp Off

2 = Effective Load,
Lamp Flashing

3 = Lamp On

Step 6 Calculate PCD Group Loads

IF \emptyset FF = F(XI(J,1),XX(J,K)) at XX(J,K) = VBUS

IF \emptyset N = F(XI(J,2),XX(J,K)) at XX(J,K) = VBUS

PF \emptyset N = VBUS * IF \emptyset N

PF \emptyset FF = VBUS * IF \emptyset FF

Step 6 (contd)

Where: $IF\emptyset FF$ = PCD Group Lamp-Off Operating Current - Amperes

$IF\emptyset N$ = PCD Group Lamp-Flashing Operating Current - Amperes

$PF\emptyset FF$ = PCD Group Lamp-Off Load - Watts

$PF\emptyset N$ = PCD Group Lamp-Flashing Load - Watts

Step 7 Obtain Free Format Data on Week Number and Compare with Reference

$LWEEK$ = Weeks after Start of the year - (1,52)

If: $LWEEK < 0$, OR,

If: $LWEEK > 52$,

Then: GO TO STEP 53

$NWEEK$ = $LWEEK$

Step 8 Calculate Date After Start of the Year

$DATE$ = $(7.0 * NWEEK) - 6.0$

Step 9 Obtain Terminator Characteristics

SRT = Sunrise Time - Hours after Midnight

SST = Sunset Time - Hours after Midnight

$THETLA$ = Buoy Latitude - Radians $\begin{cases} + \text{ North} \\ - \text{ South} \end{cases}$

$HOURT$ = Terminator Hour Angle - Radians

ET = Equation of Time Difference - Hours

$DECL$ = Solar Declination Angle - Radians

$ALPHAEQ$ = Solar Vector Location - Radians

Step 11 Calculate Daily Time Increment

$$DTIMEH = (SST - SRT)/10.0$$

Where: DTIMEH = Daily Time Increment for Clear Day Solar
Insolation Calculations - Hours

Step 12 Initialize Daily Time and Time Increment Counter

$$LTIME = 1$$

$$TIMEH = SRT$$

Where: LTIME = Time Increment Counter

Step 13 Compare Time Increment Counter With Reference

If: LTIME = 1,
Then: { QDTC = 0.0
SALT = 0.0 } , AND, GO TO STEP 16
QSOL(1) = 0.0

Where: QDTC = Clear Day Solar Insolation Incident on
Solar Array - Watts/Meter²

SALT = Solar Altitude - Radians

Step 14 Compare Time Increment Counter With Reference

If: LTIME = 11,
Then: { QDTC = 0.0
SALT = 0.0 } , AND GO TO STEP 16
QSOL(11) = 0.0

Step 14a Compare Environmental Tape Index with Reference

If: ITAPE = 0
Then: GO TO STEP 15

Step 14b Obtain Solar Insolation from "MERGE" File

QDT = Solar Insolation Incident on Solar Array -
Watts/Meter²

Step 14c Calculate Solar Insolation Incident on Solar Array

$$QSOL(LTIME) = QDT$$

GO TO STEP 16

Where: $QSOL$ = Solar Insolation Incident on Solar Array at
 $TIMEC$ - Watts/Meter²

Step 15 Obtain Clear Day Solar Insolation and Solar Altitude

$QDTC$ = Clear Day Solar Insolation Incident on Solar
 Array - Watts/Meter²

$SALT$ = Solar Altitude - Radians

Step 16 Calculate Clear Day Solar Insolation Array and Solar Altitude
 Array

$$QSOLC(LTIME) = QDTC$$

$$SALTA(LTIME) = SALT$$

$$TIMEC(LTIME) = TIMEH$$

Where: $QSOLC$ = Clear Day Solar Insolation Incident on Solar
 Array at $TIMEC$ - Watts/Meter²

$SALTA$ = Solar Altitude at $TIMEC$ - Radians

$TIMEC$ = Daily Time - Hours after Midnight

$LTIME$ = 1,11 (Number of data points)

Step 17 Increment Daily Time and Time Increment Counter

$$LTIME = LTIME + 1$$

$$TIMEH = TIMEH + DTIMEH$$

Step 18 Compare Time Increment Counter With Reference

If: LTIME > 11,
Then: GO TO STEP 19

RETURN TO STEP 13

Step 19 Initialize Day Counter and Weekly Summary Arrays

LDAY = 1

NMR(NWEEK) = 0

TJT(NWEEK) = 0.0

TKT(NWEEK) = 0.0

TLT(NWEEK) = 0.0

QQSOLT(NWEEK) = 0.0

QSOLMX(NWEEK) = 0.0

Where: LDAY = Day of the Week Indicator - (Range 1,7)

NMR = Weekly Number of Battery Operating Mode
 Reversals - (Charging or Discharging)

TJT = Weekly Duration of Solar Occultations - Hours

TKT = Weekly Duration of Share-Mode Operations -
 Hours

TLT = Weekly Duration of Battery-Charging Periods -
 Hours

QQSOLT = Weekly Total of Solar Insolation Incident on
 Solar Array - Watt-Hours/Meter²

QSOLMX = Maximum Solar Insolation, Incident on Solar
 Array, Encountered during week - Watts/Meter²

Step 19a Compare Environmental Tape Index with Reference

If: ITAPE = 0
Then: GO TO STEP 20

GO TO STEP 23

Step 20 Obtain Cloud Cover Conditions

CT(LDAY) = Cloud type

0.0 = Cirrus or Cirrostratus Clouds

1.0 = Stratus Clouds

2.0 = Other Cloud Types

TC(LDAY) = Total Cloud Cover

1.0 = 1/10 of sky covered

2.0 = 2/10 of sky covered

⋮

9.0 = 9/10 of sky covered

10.0 = 10/10 of sky covered

ICT = 1 + IFIX(CT)

Where: ICT = Cloud Type indicator

1 = Cirrus or Cirrostratus Clouds

2 = Stratus Clouds

3 = Other Cloud Types

Step 21 Calculate Cloud Cover ModifierIf: TC = 0.0,Then: CCMM(LTIME) = 1.0 AND GO TO STEP 22If: SALTA(LTIME) \leq $\pi/4.0$,Then: ISALT = 1If: SALT(LTIME) $>$ $\pi/4.0$,Then: ISALT = 2

CCMM(LTIME) = PC(ICT,ISALT) + P1(ICT,ISALT) * TC + ...

+ P2(ICT,ISALT) * (TC**2.0) + ...

+ P3(ICT,ISALT) * (TC**3.0)

For LTIME = 1,11

Step 21 (contd)

Where: ISALT = Solar Altitude Indicator
 CCMM(LTIME) = Cloud Cover Modifier
 P0, P1, P2, P3 = Polynomial Coefficients obtained from
 input data tables "Cloud Cover Modifier
 Polynomial Coefficients".

Step 22 Calculate Solar Insolation Incident on Solar Array

$$QSOL(LTIME) = CCMM(LTIME) * QSOLC(LTIME)$$

For LTIME = 1,11

Step 23 Calculate Total Daily Solar Radiation Incident on Solar Array

$$QQSOL = \int_{LTIME=1}^{LTIME=11} QSOL(LTIME) * DTIMEH \quad \left\{ \begin{array}{l} \text{Using Simpsons' Rule} \\ \text{of Integration} \end{array} \right.$$

Where: QQSOL = Total Daily Solar Insolation Incident on Solar
 Array - Watt-Hours/Meter²

Step 24 Calculate Maximum Solar Radiation

$$QSOLM(LDAY) = AMAX(QSOL(LTIME)) \text{ over the range: } LTIME = 1,11$$

Where: QSOLM = Maximum Solar Insolation, Incident on Solar
 Array, Encountered during the Day -
 Watts/Meter²

Step 25 Initialize Time Increment and Flasher Load Counters

LTIME = 2
 JTOFF = 1
 JTON = 1
 JOFFMX = 0
 JONMX = 0

Step 25 (contd)

Where: JTOFF = Flasher Load Turn-off Period Counter
 JTON = Flasher Load Turn-on Period Counter
 JOFFMX = Flasher Turn-off Counter
 JONMX = Flasher Turn-on Counter

Step 26 Compare Solar Insolation Incident on Solar Array With Reference

If: QSOL(LTIME) \geq QOFF
Then: GO TO STEP 27

GO TO STEP 31

Step 27 Compare Lamp Flasher Condition Indicator With Reference

If: INDFLS = 1
Then: GO TO STEP 28

GO TO STEP 31

Step 28 Calculate Time of Lamp Flasher Turn-Off

TOFF(JTOFF) = F {TIMEC(LTIME), QSOL(LTIME)}

at: QSOL(LTIME) = QOFF and during the time
 interval: TIMEC(LTIME - 1) to TIMEC(LTIME)

Where: TOFF = Time at which Lamp Flasher Turns Off - Hours
 after Midnight

Step 29 Reset Lamp Flasher Condition Indicator

INDFLS = 0

Step 30 Increment Load Counters

JTOFF = JTOFF + 1
 JOFFMX = JTOFF - 1
 GO TO STEP 36

Step 31 Compare Solar Insolation Incident on Solar Array With Reference

If: QSOL(LTIME) \leq QON

Then: GO TO STEP 32

GO TO STEP 36

Step 32 Compare Lamp Flasher Condition Indicator With Reference

If: INDFLS = 0

Then: GO TO STEP 33

GO TO STEP 36

Step 33 Calculate Time of Lamp Flasher Turn-On

TON(JTON) = F{TIMEC(LTIME), QSOL(LTIME)}

at: QSOL(LTIME) = QON, and during the time
interval: TIMEC(LTIME - 1) to TIMEC(LTIME)

Where: TON = Time at which lamp flasher turns-on - Hours after
Midnight

Step 34 Reset Lamp Flasher Conditions Indicator

INDFLS = 1

Step 35 Increment Load Counters

JTON = JTON + 1

JONMX = JTON - 1

Step 36 Increment Daily Time Counter

LTIME = LTIME + 1

Step 37 Compare Daily Time Counter With Reference

If: LTIME > 11,

Then: GO TO STEP 38

RETURN TO STEP 26

Step 38 Calculate Daily Mode Reversals of Battery

$$DNMR = JOFFMX + JONMX$$

Where: DNMR = Daily Operational Mode Reversals of Battery

Step 39 Calculate Daily Solar Occultation Periods

$$TJ = SRT + (24.0 - SST)$$

Where: TJ = Duration of Daily Solar Occultation Periods - Hours

Step 40 Initialize Daily Share-Mode and Battery Charging Periods

$$TL = 0$$

$$TK = TOFF (1) - SRT$$

Where: TL = Duration of Daily Battery Charging Periods - Hours

$$TK = \text{Duration of Daily Share-Mode Periods} - \text{Hours}$$

Step 41 Initialize Load Counters

$$JTON = 1$$

$$JTOFF = 1$$

Step 42 Compare Load Counters

If: JTOFF = JTON,
 Then: GO TO STEP 43

GO TO STEP 46

Step 43 Calculate Daily Battery Charging Periods

$$DTL = TON(JTON) - TOFF(JTOFF)$$

$$TL = TL + DTL$$

Where: DTL = Battery Charge Period Increment - Hours

Step 44 Increment Turn-Off Load Counter

$$JTOFF = JTOFF + 1$$

Step 45 Compare Turn-Off Load Counter With Reference

If: JTOFF > JOFFMX,

Then: GO TO STEP 48

RETURN TO STEP 42

Step 46 Calculate Daily Share-Mode Periods

$$DTK = TOFF(JTOFF) - TON(JTON)$$

$$TK = TK + DTK$$

Where: DTK = Share-Mode Period Increment - Hours

Step 47 Increment Turn-On Load Counter

$$JTON = JTON + 1$$

RETURN TO STEP 42

Step 48 Calculate Weekly Summary of Operational Mode Periods

$$TJT(NWEEK) = TJT(NWEEK) + TJ$$

$$TKT(NWEEK) = TKT(NWEEK) + TK$$

$$TLT(NWEEK) = TLT(NWEEK) + TK$$

Step 49 Calculate Weekly Summary of Battery Mode Reversals

$$NMR(NWEEK) = NMR(NWEEK) + DNMR$$

Step 50 Calculate Weekly Summary of Solar Insolation

$$QQSOLT(NWEEK) = QQSOLT(NWEEK) + QQSOL$$

$$QSOLMX(NWEEK) = \text{AMAX} [QSOLMX(NWEEK), QSOLM(LDAY)]$$

Step 51 Increment Day Counter

$$LDAY = LDAY + 1$$

Step 52 Compare Day Counter With Reference

If: LDAY > 7,

Then: RETURN TO STEP 7

RETURN TO STEP 20

Step 53 Calculate Yearly Solar Occultation Load Energy

$$EPCDJ = PFON * \sum_{I=1}^{NWEEK} TJT(I)$$

Where: EPCDJ = Yearly Solar Occultation Load Energy -
Watts-Hours

Step 54 Calculate Yearly Share-Mode Load Energy

$$EPCDK = PFON * \sum_{I=1}^{NWEEK} TKT(I)$$

Where: EPCDK = Yearly Share-Mode Load Energy - Watt-Hours

Step 55 Calculate Yearly Battery Charging Mode Load Energy

$$EPCDL = PFOFF * \sum_{I=1}^{NWEEK} TLT(I)$$

Where: EPCDL = Yearly Battery Charging Mode Load
Energy - Watt-Hours

Step 56 Calculate Maximum Energy Storage Group Temperature

$$TTESMX = TTABMX + DTESG$$

Where: $TTESMX =$ Energy Storage Group Maximum Temperature -
°F

Step 57 Obtain Normalized Battery Current Rates

$$BRR(J,K,L) = BCQT \{VCC(J,K,L), QBB(K), TBB(L)\}$$

Where: $BRR =$ Normalized Battery Current Rates (Expressed
as the Ratio of Battery Current to Battery
Capacity) - Hours⁻¹

$VCC =$ Cell Voltage - VDC

$QBB =$ Battery State-of-Charge

$TBB =$ Battery Temperature - °F

$BCQT =$ Input Table of BRR as a function of VCC , QBB
and TBB

$J = 1, 9$ (Data Points)

$K = 1, NQBB$ (Data Points)

$L = 1, NTBB$ (Data Points)

$NQBB =$ Number of QBB entries in $BCQT$

$NTBB =$ Number of TBB entries in $BCQT$

Step 58 Calculate Minimum Storage Cell Discharge Voltage

$$VCDMN = F \{BRR(J,K,L), QBB(K), TBB(L)\}$$

at: $BRR(J,K,L) = - |BRDEST|$

$QBB(K) = QBRES$

$TBB(L) = TTESMX$

Where: $VCDMN =$ Minimum Storage Cell Discharge Voltage -
VDC

Step 59 Calculate Minimum Storage Cell Charge Voltage

$$VCCMN = F \{BRR(J,K,L), QBB(K), TBB(L)\}$$

$$\text{at: } BRR(J,K,L) = BRCEST$$

$$QBB(K) = QBRES$$

$$TBB(L) = TTESMX$$

Where: VCCMN = Minimum Storage Cell Charge Voltage - VDC

Step 60 Calculate Minimum Battery Potential Efficiency

$$ETABVN = VCDMN/VCCMN$$

Where: ETABVN = Minimum Battery Potential Efficiency

Step 61 Calculate Battery State-of-Charge Increment

$$DQBB1 = (1.0 - QBRES)/10.0$$

Where: DQBB1 = Battery State-of-Charge Increment

Step 62 Initialize Battery SOC Counter and SOC Values

$$IQBB = 1$$

$$QBB1 = QBRES$$

Where: IQBB = Battery State-of-Charge Counter

QBB1 = Battery State-of-Charge

Step 63 Calculate Instantaneous Battery Coulombic (Charge) Efficiency

$$ETA(IQBB) = A \{BRR, QBB, TBB\}$$

$$\text{at: } BRR = BRCEST$$

$$TBB = TTESMX$$

$$QBB = QBB1$$

Where: $ETA(IQBB)$ = Instantaneous Battery Coulombic Efficiency

A = A series of Input Data Tables (A1, A2, A3, A4, A5) giving ETA as a function of BRR, QBB and TBB

Step 64 Increment Battery SOC Counter and SOC Values

$$IQBB = IQBB + 1$$

$$QBB1 = QBB1 + DQBB1$$

Step 65 Compare Battery SOC Counter With Reference

If: $IQBB > 11$,

Then: GO TO STEP 67

RETURN TO STEP 63

Step 66 Calculate Average Battery Coulombic (Charge) Efficiency

$$ETABQ = \left(\frac{1.0}{1 - QBRES} \right) * \int_{IQBB=1}^{IQBB=11} ETA(IQBB) * DQBB1 \left\{ \begin{array}{l} \text{Using Simpsons' Rule of} \\ \text{Integration} \end{array} \right.$$

Where: $ETABQ$ = Average Battery Coulombic Efficiency

Step 67 Calculate Battery Energy Charge/Discharge Ratio

$$RATBAT = 1.0 / (ETABVN * ETABQ)$$

Where: $RATBAT$ = Battery Energy Charge/Discharge Ratio

Step 68 Compare Battery Charger Type With Reference

If: ICHRT = 0,
Then: GO TO STEP 75

Step 69 Calculate Battery Discharge Line Efficiency

$$ETAD = VBUS / (VBUS + 1.0)$$

Where: ETAD = Battery Discharge Line Efficiency

Step 70 Compare Raw Power Bus Operating Level With Reference

VCHIO = VCHIOT {TTESG} at: TTESG = TTESMX

If: VBUS \leq VCHIO,
Then: GO TO STEP 74

Where: VCHIO = Battery Charger Input Voltage at Turn-on
 (Minimum Voltage Drop at zero current level) -
 VDC

VCHIOT = Input Table of VCHIO as a function of TTESG

TTESG = Energy Storage Group Temperature - °F

Step 71 Compare Raw Power Bus Operating Level With Reference

VCHISA = VCHIST {TTESG} at: TTESG = TTESMX

If: VBUS \leq VCHISA,
Then: GO TO STEP 72

GO TO STEP 73

Where: VCHISA = Battery Charger Input Voltage wherein Charger
 Changes From "Saturated" operation to "Active"
 Operation - VDC

VCHIST = Input Table of VCHISA as a function of TTESG

Step 72 Calculate Battery Charger Efficiency

$$ETACHG = 1.0 - (VCHIO/VBUS)$$

GO TO STEP 76

Where: ETACHG = Battery Charger Efficiency

Step 73 Calculate Battery Charger Efficiency

$$ETACHG = (VCHISA - VCHIO)/VBUS$$

GO TO STEP 76

Step 74 Calculate Battery Charger Efficiency

$$ETACHG = 0.0$$

GO TO STEP 76

Step 75 Calculate Battery Discharge Line Efficiency and Charger Efficiency

$$ETAD = 1.0$$

$$ETACHG = 1.0$$

Step 76 Calculate Duration of Yearly Share-Mode Loads

$$TKTT = \sum_{I=1}^{N\text{WEEK}} TKT(I)$$

Where: TKTT = Duration of Yearly Share-Mode Loads - Hours

Step 77 Calculate Duration of Yearly Battery Charge Mode Loads

$$TLTT = \sum_{I=1}^{NWEEK} TLT(I)$$

Where: TLTT = Duration of Yearly Battery Charge Mode Loads - Hours

Step 78 Calculate Power Source Group (PSG) Average Power Level

$$PPSGAV = \frac{RATBAT * (EPCDJ + EPCDK) + (ETAD * ETACHG * EPCDL)}{(ETAD * ETACHG * TLTT) + (RATBAT * TKTT)}$$

Where: PPSGAV = PSG Average Power Level During Year - Watts

Step 79 Calculate PSG Energy Requirement

$$EPSG = PPSGAV * (TKTT + TLTT)$$

Where: EPSG = PSG Yearly Energy Requirement - Watt-Hours

Step 80 Calculate Solar Array Energy Requirement

$$ESA = EPSG / \left(\frac{VBUS}{VBUS + 1.0} \right)$$

Where: ESA = Solar Array Yearly Energy Requirement - Watt-Hours

Step 81 Calculate Maximum Solar Array Temperature

$$TSAFMX = TABMX + DTTPSG$$

$$TSARMX = TSAFMX + 459.67$$

$$TSAKMX = (5.0/9.0) * TSARMX$$

$$TSACMX = TSAKMX - 273.15$$

Where: TSAFMX = Maximum Solar Array Temperature - °F

TSARMX = Maximum Solar Array Temperature - °R

TSAKMX = Maximum Solar Array Temperature - °K

TSACMX = Maximum Solar Array Temperature - °C

Step 82 Calculate Maximum Instantaneous Solar Radiation

$QDTMX = AMAX(QSOLMX(I))$ over the range: $I = 1, N WEEK$

Where: $QDTMX =$ Maximum Instantaneous Total Solar Radiation
Incident on Solar Array - Watts/Meter²

Step 83 Obtain Solar Array Electrical Characteristics

Under the conditions:

(a) $TSAC = TSACMX$

(b) $QDT = QDTMX$

(c) $DATEM = DURAM * 365.242$

(d) $NS1 = 50$

(e) $NP = 50$

(f) $NESP = 1$

Where: $TSAC =$ Solar Array Temperature - °C

$QDT =$ Instantaneous Total Solar Radiation Incident
on Solar Array - Watts/Meter²

$DATEM =$ Elapsed Time from start of mission - Days

$NS1 =$ No. of Solar Cells in Series in each circuit

$NP =$ No. of Solar Cells in Parallel in each circuit

$NESP =$ Number of Parallel Electrical Circuits in
Solar Array

Then: $V2(L) =$ Solar Array Voltage - VDC

$I2(L) =$ Solar Array Current at $V2(L)$ - Amperes

$L = 1, MFINAL$

$MSAPWR =$ Solar Array Maximum Power - Watts

$MAXV =$ Solar Array Voltage at Maximum Power Point -
VDC

$MAXI =$ Solar Array Current at Maximum Power Point -
Amperes

Step 83a Calculate Single Cell Maximum Power

$$PWRMX1 = MSAPWR / (NS1 * NP * NESP)$$

Where: PWRMX1 = Single Cell Maximum Power Output - Watts

Step 84 Calculate Solar Cell Efficiency for End of Mission

$$ETA EOM = (PWRMX1 / (QDT * ACELL * 10^{-4}))$$

Where: ETA EOM = End-of-Mission Solar Cell Efficiency

Step 85 Calculate Total Yearly Solar Radiation

$$QQSTOT = \sum_{I=1}^{N\text{WEEK}} QQSOLT(I)$$

Where: QQSTOT = Total Yearly Solar Radiation Incident on Solar Array - Watt-Hours/Meter²

Step 86 Calculate Nominal Estimate of Total Solar Cell Area

$$ASCTNM = \frac{ESA}{QQSTOT * ETA EOM * (1.0 - SARES)}$$

Where: ASCTNM = Nominal estimate of total solar cell area - Meter²

Step 87 Calculate Nominal Estimate of Total Solar Cells

$$XNSCNM = \frac{ASCTNM}{ACELL * (1.0 * 10^{-4})}$$

Where: XNSCNM = Nominal Estimate of Total Solar Cells

Step 88 Calculate Solar Array Open Circuit Voltage

$$VSCOC = F \{V2(L), I2(L)\} \text{ at } I2(L) = 0.0$$

Where: VSCOC = Array Open Circuit Voltage - VDC

Step 89 Calculate Number of Solar Cells in Series Required

$$XNS = \frac{VBUS + 1.0}{\left(\frac{VSCOC + MAXV}{2.0 * NS1} \right)}$$

$$NS = IFIX(XNS) + 1.0$$

Where: XNS = Estimate of Cells in Series

NS = Number of Solar Cells in Series Required

Step 90 Calculate Number of Solar Array Electrical Sections in Parallel

$$XNESP = \frac{XNSCNM}{FLOAT(NS) * FLOAT(NPREQ)}$$

$$NESP = IFIX(XNESP) + 1.0$$

Where: XNESP = Estimate of Electrical Sections in parallel

Step 91 Calculate Total Solar Cells Required

$$NSCTOT = NESP * NS * NPREQ$$

Where: NSCTOT = Total Number of Solar Cells Required for the Solar Array

Step 92 Calculate Total Solar Cell Area

$$ASCTOT = NSCTOT * ACELL (1.0 * 10^{-4})$$

Where: ASCTOT = Total Solar Cell Area Required for Solar Cell Array - Meter²

Step 93 Calculate Total Solar Array Area

$$ASA = \frac{ASCTOT}{CELPAC * (9.290 * 10^{-2})}$$

Where: ASA = Total Solar Array Area Required - Foot²

Step 94 Calculate Solar Array Weight

$$DWDA = DWDAT * ASA$$

$$WSA = ASA * DWDA$$

Where: DWDA = Solar Array Specific Weight - Lbs/Ft²

WSA = Solar Array Weight - Lbs

DWDAT = Input Table of DWDA as a function of ASA

Step 95 Calculate Solar Array Cost

$$ASATP = ASA * FLOAT (NSAP)$$

$$DCDA = DCDAT (ASATP)$$

$$CSA = ASA * DCDA$$

Where: ASATP = Total Area of Solar Arrays to be procured - Ft²

CSA = Solar Array Cost - \$

DCDA = Solar Array Specific Cost - \$/Ft²

DCDAT = Input Table of DCDA as a Function of ASATP

Step 96 Calculate Minimum Solar Array Temperature

$$TSAFMN = TTABMN + DTPSG$$

$$TSARMN = TSAFMN + 459.67$$

$$TSAKMN = (5.0/9.0) * TSARMN$$

$$TSACMN = TSAKMN - 273.15$$

Where: TSAFMN = Minimum Solar Array Temperature - °F

TSARMN = Minimum Solar Array Temperature - °R

TSAKMN = Minimum Solar Array Temperature - °K

TSACMN = Minimum Solar Array Temperature - °C

Step 97 Obtain Solar Array Current Voltage Characteristics at the Beginning of Life

Under the conditions:

- (a) TSAC = TSACMN
 - (b) QDT = QDTMX
 - (c) DATEM = 0.0
 - (d) NP = NPREQ
 - (e) NS = NS
 - (f) NESP = NESP
- (from above
Calculations

Then: V2(L) = Solar Array Voltage - VDC

I2(L) = Solar Array Current at V2(L) - Amperes

L = 1, MFINAL

MSAPWR = Solar Array Maximum Power - Watts

MAXV = Solar Array Voltage at Maximum Power Point - VDC

MAXI = Solar Array Current at Maximum Power Point - Amperes

Step 98 Calculate Solar Array Open Circuit Voltage (at BOL)

VSAOC = F {V2(L), I2(L)} at I2(L) = 0.0

Where: VSAOC = Solar Array Open Circuit Voltage - VDC

Step 99 Calculate Maximum Blocking Diode Power Loss

$$MSABDP = \left(\frac{1.0}{V_{BUS} + 1.0} \right) * MSAPWR$$

Where: MSABDP = Maximum Power Loss in all Solar Array Blocking Diodes - Watts

Step 100 Calculate Solar Array Electrical Section Blocking Diode Rating

$$PESBD = MSABDP / FLOAT (NESP)$$

Where: PESBD = Electrical Section Blocking Diode Power Rating - Watts

Step 101 Initialize Weekly Counter and Battery State

$$N WEEK = 1.0$$

$$BSTATE = 0.0$$

$$EBTHMX = 0.0$$

$$EBTHMN = 0.0$$

Where: BSTATE = Relative Energy State of the Battery - Watt-Hours

EBTHMX = Maximum Battery Energy State - Watt-Hours

EBTHMN = Minimum Battery Energy State - Watt-Hours

Step 102 Compare Weekly Counter With Reference

If: N WEEK < 0 ; OR

If: N WEEK > 52 ; OR

If: N WEEK > L WEEK :

Then: GO TO STEP 113

Step 103 Calculate Average Weekly Solar Insolation

$$QQSOLA = QQSTOT / FLOAT (N WEEK)$$

Where: QQSOLA = Average Weekly Solar Radiation Incident on Solar Array - Watt-Hours/Meter²

Step 104 Calculate Modified PSG Power Output

$$\text{PPSGL} = \frac{\text{PPSGAV} * \text{QQSOLT}(\text{N WEEK})}{\text{QQSOLA}}$$

$$\text{PPSGK} = \frac{\text{PPSGL} * \text{QOFF}}{\text{QSOLMX}(\text{N WEEK})}$$

Where: PPSGL = Weekly Average PSG power output during battery charging periods - Watts

PPSGK = Weekly Average PSG power output during Share-Mode Operational periods - Watts

Step 105 Calculate Battery Load Profile Power Levels

$$\text{PBJ} = -\text{PFON}/\text{ETAD}$$

$$\text{PGK} = -(\text{PFON} - \text{PPSGK})/\text{ETAD}$$

$$\text{PBL} = (\text{ETACHG}/\text{RATBAT}) * (\text{PPSGL} - \text{PFOFF})$$

Where: PBJ = Battery Discharge Power during Solar Occultation periods - Watts

PBK = Battery Discharge Power during Share-Mode Operation periods - Watts

PBL = Battery Charge Power, adjusted to reflect Net gain in discharge energy, during Battery Charging periods - Watts

Step 106 Compare Share-Mode Battery Discharge Power with Reference

If: PBK > 0.0,

Then: PBK = 0.0

Step 107 Calculate Battery Energy Profile Levels

$$EBX(1) = PBJ * TJL(NWEEK)$$

$$EBX(2) = PBK * TKT(NWEEK)$$

$$EBX(3) = PBL * TLT(NWEEK)$$

$$EBDX(1) = EBX(1)/7.0$$

$$EBDX(2) = EBX(2)/7.0$$

$$EBDX(3) = EBX(3)/7.0$$

Where: EBX(I) = Battery Discharge Energy during a particular operational period - Watt-Hours

EBDX(I) = Average Daily Battery Discharge Energy

I = 1 = During Solar Occultation periods

= 2 = During Share-Mode periods

= 3 = During Battery charging periods

Step 108 Initialize Period Counter

$$I = 1$$

Step 109 Compare Period Counter With Reference

If: I > 3,

Then: GO TO STEP 112

Step 110 Calculate Battery Energy State

$$BSTATE = BSTATE + EBDX(I)$$

$$EBTHMX = AMAX (EBTHMX, BSTATE)$$

$$EBTHMN = AMIN (EBTHMN, BSTATE)$$

Step 111 Increment Period Counter

$$I = I + 1$$

RETURN TO STEP 109

Step 112 Increment Weekly Counter

$$N\text{WEEK} = N\text{WEEK} + 1$$

RETURN TO STEP 102

Step 113 Calculate Theoretical Battery Discharge Energy Requirement

$$EBDTH = \text{ABS} (EBTHMX - EBTHMN)$$

Where: EBDTH = Theoretical Battery Discharge Energy -Watt-Hours

Step 114 Calculate First Criterion for Energy Storage Group Discharge Energy

$$EESG1 = EBDTH / (1.0 - QBRES)$$

Where: EESG1 = First Criterion for ESG Discharge
Energy - Watt-Hours

Step 115 Calculate Yearly Battery Mode Reversals

$$NMRT = \sum_{I=1}^{N\text{WEEK}} NMR(I)$$

Where: NMRT = Total Yearly Reversals of Battery Operating Mode

Step 116 Calculate Total Mission Battery Cycle Requirements

$$NCYCLE = \text{FLOAT} \left[\left(\frac{52.0 * DURAM}{2.0} \right) * \left(\frac{\text{FLOAT}(NMRT)}{\text{FLOAT}(N\text{WEEK})} \right) \right] + 1$$

Where: NCYCLE = Battery Charge/Discharge Cycle Requirement

Step 117 Calculate Theoretical Battery Depth-of-Discharge

$$DOD = DODT \{ \ln \text{ NCYCLE} \}$$

Where: DOD = Theoretical Battery Depth of Discharge

DODT = Input Table of DOD as a function of the natural logarithm of NCYCLE

Step 118 Compare Theoretical Depth of Discharge With Reference

If: DOD < 0.0,
Then: DOD = 0.001

If: DOD > 1.0,
Then: DOD = 1.0

Step 119 Calculate Second Criterion for Battery Discharge Energy Requirement

$$EESG2 = EBDTH/DOD$$

Where: EESG2 = Second Criterion for ESG Discharge
Energy - Watt-Hours

Step 120 Calculate PSG Maximum Power Output

$$PPSGMX = MSAPWR - MSAPDP$$

Where: PPSGMX = PSG Maximum Power Output - Watts

Step 121 Calculate Maximum Battery Charge Power

$$PBCHMX = ETACHG * (PPSGMX - PPOFF)$$

Where: PBCHMX = Maximum Power Available for Battery
Charging - Watts

Step 122 Calculate ESG Minimum Temperature

$$TTESMN = TTABMN + DTESG$$

Where: $TTESMN$ = Minimum Temperature of ESG - °F

Step 123 Calculate Maximum Storage Cell Discharge Voltage

$$VCDMX = F \{BRR(J,K,L), QBB(K), TBB(L)\}$$

$$\text{at: } BRR(J,K,L) = -|BRDEST|$$

$$QBB(K) = 1.0$$

$$TBB(L) = TTESMN$$

Where: $VCDMX$ = Maximum Storage Cell Discharge Voltage - VDC

Step 124 Calculate Maximum Storage Cell Charge Voltage

$$VCCMX = F \{BRR(J,K,L), QBB(K), TBB(L)\}$$

$$\text{at: } BRR(J,K,L) = BRCEST$$

$$QBB(K) = 1.0$$

$$TBB(L) = TTESMN$$

Where: $VCCMX$ = Maximum Storage Cell Charge Voltage - VDC

Step 125 Calculate Maximum Battery Potential Efficiency

$$ETABVX = VCDMX/VCCMX$$

Where: $ETABVX$ = Maximum Battery Potential Efficiency

Step 126 Calculate Third Criterion for Battery Discharge Energy Requirement

$$EESG3 = \frac{PBCHMX * ETABVX}{BRCHMX}$$

Where: $EESG3$ = Third criterion for ESG Discharge Energy - Watt-Hours

Step 127 Calculate Actual Battery Energy Discharge Capability

$EESG = \text{AMAX}(EESG1, EESG2, EESG3)$

Where: $EESG = \text{ESG Discharge Energy Capability} - \text{Watt-Hours}$

Step 129 Compare Battery Charger Type With Reference

If: $ICHRT > 0,$

Then: GO TO STEP 133

Step 130 Compare Shunt Limiter Type With Reference

If: $ISH > 0,$

Then: GO TO STEP 132

Step 131 Calculate Maximum Battery Charge Voltage

$VBCHMX = VSAOC - 1.0$

GO TO STEP 139

Where: $VBCHMX = \text{Maximum Battery Charge Voltage} - \text{VDC}$

Step 132 Calculate Maximum Battery Charge Voltage

$VBCHMX = VBUS + (0.75) * ((VSAOC - 1.0) - VBUS)$

GO TO STEP 139

Step 133 Compare Shunt Limiter Type with Reference

If: $ISH > 0,$

Then: $ISH = 0$

Step 134 Calculate Battery Charger Reference Voltages

$VCHIO = VCHIOT \{TTESG\}$
 $VCHISA = VCHIST \{TTESG\}$ } at: $TTESG = TTESMN$

Step 134 (contd)

Where: VCHIO = Battery Charger Input Voltage at Turn-On - VDC

VCHISA = Battery Charger Input Voltage at which charger changes from "Saturated" to "Active" operation - VDC

VCHIOT = Input Table of VCHIO as a function of TTESG

VCHIST = Input Table of VCHISA as a function of TTESG

Step 135 Compare Solar Array Open Circuit Voltage With Reference

If: (VSAOC - 1.0) > VCHIO,

Then: GO TO STEP 136

Print Out Error Message:

"VBUS too low to turn-on battery charger"

Return to Main Program and Stop Computer Run

Step 136 Compare Solar Array Open Circuit Voltage With Reference

If: (VSAOC - 1.0) > VCHISA,

Then: GO TO STEP 138

Step 137 Calculate Maximum Battery Charge Voltage

VBCHMX = (VSAOC - 1.0) - VCHIO

GO TO STEP 139

Step 138 Calculate Maximum Battery Charge Voltage

VBCHMX = F (VESA, TTESG)

at: VESA = VSAOC - 1.0

TTESG = TTESMN

Step 138 (contd)

Where: $VESA = VCHIT \{VCHOOA, TTESG\}$

$VCHOOA = VBCHMX$

$VESA =$ Estimate of Battery Charger Input Voltage in "active" condition - VDC

$VCHOOA =$ Battery Charger Output Voltage, in "active" condition at zero current - VDC

$VCHIT =$ Input Table of VESA as a function of VCHOOA and TTESG

Step 139 Calculate Storage Cell Minimum Charge Voltage

$VCCHMN = F \{BRR(J,K,L), QBB(K), TBB(L)\}$

at: $BRR(J,K,L) = 0.0$

$QBB(K) = 1.0$

$TBB(L) = TTESMX$

Where: $VCCHMN =$ Storage Cell Minimum Charge Voltage - VDC

Step 140 Calculate Maximum Number of Storage Cells in Series

$XNCBMX = VBCHMX/VCCHMN$

Where: $XNCBMX =$ Estimated Maximum Number of Storage Cells in Series

Step 141 Calculate Storage Cell Maximum Charge Voltage

$VCCHMX = F \{BRR(J,K,L), QBB(K), TBB(L)\}$

at: $BRR(J,K,L) = 0.0$

$QBB(K) = 1.0$

$TBB(L) = TTESMN$

Where: $VCCHMX =$ Storage Cell Maximum Charge Voltage - VDC

Step 142 Calculate Minimum Number of Storage Cells in Series

$$XNCBMN = VBUSMN / VCCHMX$$

Where: XNCBMN = Estimated Minimum Number of Storage Cells in Series

Step 143 Calculate Estimated Storage Cells in Series

$$XNCELL = XNCBMN + (FRCELL) * (XNCBMX - XNCBMN)$$

Where: XNCELL = Estimated Storage Cells in Series

Step 144 Calculate Actual Number of Storage Cells in Series

$$NCELL = IFIX(XNCELL)$$

$$YNCELL = FLOAT(NCELL)$$

$$DNCELL = XNCELL - YNCELL$$

If: DNCELL \geq 0.5,

Then: NCELL = NCELL + 1

Where: NCELL = Number of Storage Cells in Series in the Battery

Step 145 Initialize Voltage Counter and Battery State-of-Charge

$$I = 1$$

$$QBS = 0.0$$

Where: QBS = Dummy Variable used for Battery State-of-Charge

Step 146 Compare Voltage Counter With Reference

If: I > 11,

Then: GO TO STEP 149

Step 147 Calculate Storage Cell Discharge Voltage

$$VCDSTD(I) = F \{BRR(J,K,L), QBB(K), TBB(L)\}$$

$$\text{at: } BRR(J,K,L) = -|BRDSTD|$$

$$QBB(K) = QBS$$

$$TBB(L) = TBDSTD$$

Where: VCDSTD = Storage Cell Discharge Voltage under Standard Conditions of BRDSTD and TBDSTD - Volts

Step 148 Increment Voltage Counter and Battery State-of-Charge

$$QBS = QBS + 0.1$$

$$I = I + 1$$

RETURN TO STEP 146

Step 149 Calculate Average Storage Cell Discharge Voltage

$$VCDAVG = \int_{I=1}^{I=11} VCDSTD(I) * (0.1) \left. \vphantom{\int} \right\} \text{ Using Simpsons' Rule}$$

Where: VCDAVG = Average Storage Cell Discharge Voltage Under Standard Conditions - VDC

Step 150 Calculate Total ESG Discharge Capacity

$$CBDSTD = \frac{EESG}{VCDAVG * FLOAT(NCELL)}$$

Where: CBDSTD = Total ESG Discharge Capacity Under Standard Conditions - Amp-Hours

Step 151 Initialize Storage Cell Size Counter

$$JB = 1$$

Where: JB = Tabular Location Size of Available Storage Cell

Step 152 Compare Storage Cell Size Counter With Reference

If: JB > 30
Then: GO TO STEP 154

Step 153 Compare Storage Cell Size With Reference

If: CBAVAL(JB) > 0.0,
Then: JB = JB + 1, AND
Then: RETURN TO STEP 152

Step 154 Calculate Maximum Number of Storage Cell Table Entries

JBTOT = JB

Where: JBTOT = Max. No. of Entries in Storage Cell Table

Step 155 Initialize Storage Cell Size Counter

JB = 1

Step 156 Compare Storage Cell Size Counter With Reference

If: JB > JBTOT,
Then: JBMAX = JBTOT, AND
Then: GO TO STEP 159

Where: JBMAX = Location of Max. Available Battery Capacity in
Storage Cell Table

Step 157 Compare Maximum Desired Battery Capacity With Reference

If: CBMAX > CBAVAL(JB),
Then: JB = JB + 1, AND
Then: RETURN TO STEP 156

Step 158 Calculate Location of Maximum Desired Battery Capacity in
Available Storage Cell Table

JBMAX = JB - 1

Step 159 Calculate Estimate of Batteries Required

$$\text{XNBATT} = \frac{\text{CBDSTD}}{\text{CBAVAL}(\text{JBMAX})}$$

Where: XNBATT = Estimate of Number of Batteries in Parallel

Step 160 Compare Estimate of Batteries Required With Reference

If: XNBATT > 1.0,
Then JBB = JBMAX, AND
Then: GO TO STEP 166

Where: JBB = Location of Selected Design Capacity in Storage Cell Table

Step 161 Initialize Counter

J = 1

Step 162 Compare Counter With Reference And Select Battery Attribute

If: J = JBMAX,
Then: NBATT = 1, AND,
Then: CBDT = CBDSTD, AND,
Then: CBD = CBDT, AND,
Then: GO TO STEP 174

Where: NBATT = Number of Batteries in Parallel

CBDT = Total Discharge Capacity of all batteries - Amp-Hours

CBD = Discharge Capacity of a single battery - Amp-Hours

Step 163 Calculate Location of Selected Battery Design Capacity in Storage Cell Table

JBB = JMAX - J

Step 164 Calculate Estimate of Number of Batteries in Parallel

$$\text{XNBATT} = \frac{\text{CBDSTD}}{\text{CBAVAL}(\text{JBB})}$$

Step 165 Compare Estimate of Batteries Required With Reference

If: XNBATT < 1.0
Then: J = J + 1, AND,
Then: RETURN TO STEP 162

Step 166 Compare Estimate of Batteries Required With Reference

If: XNBATT < 10.0
Then: GO TO STEP 172

Step 167 Increment Maximum Desired Battery Capacity Location in Storage Cell Table

JBMAX = JBMAX + 1

Step 168 Compare Maximum Desired Battery Capacity Location With Reference and Select Battery Attributes

If: JBMAX > JBTOT,
Then: NBATT = 10, AND,
Then: CBDT = CBDSTD, AND,
Then: CBD = CBDT/FLOAT(NBATT); AND,
Then: GO TO STEP 174

Step 169 Calculate Location of Selected Battery Design Capacity in Storage Cell Table

JBB = JBMAX

Step 170 Calculate Estimate of Number of Batteries in Parallel

XNBATT = CBDSTD/CBAVAL(JBB)

Step 171 Compare Estimate of Batteries Required With Reference

If: XNBATT > 10.0,
Then: RETURN TO STEP 167

Step 172 Calculate Actual Number of Batteries in Parallel

$$NBATT = IFIX(XNBATT)$$

$$YNBATT = FLOAT(NBATT)$$

$$DNBATT = XNBATT - YNBATT$$

$$\text{If: } DNBATT \geq 0.5,$$

$$\text{Then: } NBATT = NBATT + 1$$

Step 173 Calculate Battery and ESG Storage Capacity

$$CBD = CBAVAL(JBB)$$

$$CBDT = CBD * FLOAT(NBATT)$$

Step 174 Calculate Maximum Allowable Battery Charging Current

$$EBDA = CBDT * VCD AVG * FLOAT(NCELL)$$

$$DODA = EBDTH/EBDA$$

$$YICHMX = CBDT * BRCHMX$$

$$ZICHMX = YICHMX/FLOAT(NBATT)$$

Where: EBDA = Total Battery Energy Watt-Hours

DODA = Maximum Battery Depth-of-Discharge

YICHMX = Maximum Allowable Battery Charging Current for
the ESG - Amperes

ZICHMX = Maximum Allowable Charging Current for Single
Battery - Amperes

Step 175 Calculate Battery Weight

$$DWDE = DWDET \{CBD\}$$

$$EBTOT = CBDT * VCDAVE * FLOAT \{NCELL\}$$

$$WBATT = DWDE * EBTOT$$

Where: DWDE = Battery Specific Weight - lbs/Watt-Hour

EBTOT = Total Battery Energy in ESG - Watt-Hours

WBATT = Battery Weight - Lbs

DWDET = Input Table of DWDE as a function of CBD

Step 176 Calculate Battery Cost

$$DCDE = DCDET \{CBD, NBATP\}$$

$$CBATT = DCDE * EBTOT$$

Where: DCDE = Battery Specific Cost - \$/Watt-Hour

NBATP = Total Number of Batteries to be procured

CBATT = Battery Cost - \$

DCDET = Input table of DCDE as a function of CBD and NBATP

Step 177 Compare Battery Charger Type With Reference

If: ICHRT = 0,

Then: PCHO = 0.0, AND,

Then: WCHG = 0.0, AND,

Then: CCHG = 0.0, AND,

Then: GO TO STEP 181

Where: PCHO = Maximum Load for a Single Battery Charger - Watts

WCHG = Weight of all chargers - Lbs

CCHG = Cost of all chargers - \$

Step 178 Calculate Single Charger Maximum Load

$$PCHO = PBCHMX / FLOAT(NBATT)$$

Step 179 Calculate Battery Charger Weight

$$DWDCH = DWDCHT \{PCHO\}$$

$$WCHG = DWDCH * PCHO * FLOAT(NBATT)$$

Where: DWDCH = Battery Charger Specific Weight - Lb/Watt

DWDCHT = Input Table of DWDCH as a function of PCHO

Step 180 Calculate Battery Charger Cost

$$DCDCH = DCDCHT \{PCHO, NCHGP\}$$

at: NCHGP = NBATP

Where: NCAGP = Number of Battery Chargers Procured

DCDCH = Battery Charger Specific Cost - \$/Watt

DCDCHT = Input Table of DCDCH as a Function of PCHO and NCHGP

Step 181 Compare Shunt Limiter Type With Reference

If: ISH = 0,

Then: WSL = 0.0, AND,

Then: CSL = 0.0, AND,

Then: GO TO STEP 215

Where: WSL = Total Weight of Shunt Limiters - Lbs

CSL = Total Cost of Shunt Limiters - \$

- Step 182 Calculate Shunt Limiter Operating Point
- VSLOP = VBCHMX
- XISLOP = F {I2(L), V2(L)}
- at: V2(L) = VSLOP
- Where: VSLOP = Shunt Limiter Operating Point Voltage - VDC
- XISLOP = Shunt Limiter Operating Point Current - Amperes
-
- Step 183 Compare Shunt Limiter Type With Reference
- If: ISH > 2,
- Then: GO TO STEP 208
-
- Step 184 Calculate Power Source Group Type
- IPSG = 1
- Where: IPSG = Power Source Group Type
- 0 = One Shunt Limiter for the Solar Array
- 1 = One Shunt Limiter for each electrical section of the solar array
-
- Step 185 Calculate Zener Diode Reference Power Level
- PZRF25 = HDER * HDZMX
- Where: PZRF25 = Single Zener Diode Reference Power Level at 25°C - Watts
-
- Step 186 Calculate Estimate of Zener Diodes in a Single String
- XNZS = PPSGMX / (PZRF25 * FLOAT(NESP))
- Where XNZS = Estimate of Zener Diodes in a Single String

Step 187 Calculate Actual No. of Zener Diodes in a Single String

$$N_ZS = \text{IFIX}(X_{NZS})$$

$$Y_{NZS} = \text{FLOAT}(N_ZS)$$

$$D_{NZS} = X_{NZS} - Y_{NZS}$$

If: $D_{NZS} \geq 0.5,$

Then: $N_ZS = N_ZS + 1$

If: $N_ZS < 1,$

Then: $N_ZS = 1$

Step 188 Calculate Zener Diode Operating Temperature

$$T_{CZ} = T_{SACMN}$$

Where: T_{CZ} = Zener Diode Operating Temperature - °C

Step 189 Calculate Single Zener Diode Operating Point

$$V_{ZOP} = V_{SLOP} / \text{FLOAT}(N_ZS)$$

$$X_{IZOP} = X_{ISLOP} / \text{FLOAT}(N_{ESP})$$

Where: V_{ZOP} = Zener Diode Operating Point Voltage - VDC

X_{IZOP} = Zener Diode Operating Point Current - Amperes

Step 190 Compare Shunt Limiter Type With Reference

If: $ISH > 1,$

Then: GO TO STEP 201

Step 191 Initialize Zener Diode Voltage Counter

$$L_Z = 1$$

Step 192 Initialize Zener Diode Breakdown Reference Voltage

$$V_{ZB30} = V_{ZOP}$$

Where: V_{ZB30} = Zener Diode Breakdown Voltage at 30°C - VDC

Step 193 Compare Zener Diode Voltage Counter With Reference

If: LZ > 25
Then: VZBR = VZB, AND,
Then: GO TO STEP 205

Where: VZBR = Single Zener Diode Breakdown Voltage -VDC (at Operating Temperatures)

VZB = Estimate of Zener Diode Breakdown Voltage - VDC

Step 194 Calculate Zener Diode Temperature Coefficient

TCO = ZTCOEF {VZB30}

Where: TCO = Zener Diode Temperature Coefficient - (%/°C)

ZTCOEF = Input Table of TCO as a function of VZB30

Step 195 Calculate Zener Diode Dynamic Impedance

ZZ = ZDIMP {TCZ, VZB30}

Where: ZZ = Zener Diode Impedance - Ohms

ZDIMP = Input Table of ZZ as function of TCZ and VZB30

Step 196 Calculate Estimate of Zener Diode Breakdown Voltage

VZB = VZOP - (XIZOP * ZZ)

Step 197 Calculate Estimate of Reference Temperature Zener Breakdown Voltage

$$VZB301 = VZB * \left[1.0 - \frac{TCO * (TCZ - 30.0)}{100.0} \right]$$

Where: VZB301 = Estimate of Zener Diode Breakdown Voltage at 30°C - VDC

Step 198 Calculate Breakdown Voltage Residual

$$DVZB = \text{ABS} \left(\frac{VZB301 - VZB30}{VZB30} \right)$$

Where: DVZB = Residual in Estimate of Zener Diode Breakdown Voltage at 30°C - VDC

Step 199 Compare Breakdown Voltage Residual With Reference

If: DVZB \leq 0.01,
Then: VZBR = VZB, AND,
Then: GO TO STEP 205

Step 200 Increment Zener Diode Voltage Counter and Adjust Reference Breakdown Voltage

$$LZ = LZ + 1$$

$$VZB30 = VZB301$$

RETURN TO STEP 193

Step 201 Calculate Temperature Compensated (TC) Zener Reference Current

$$IZRF25 = \text{CURZ} (\text{HDZMX})$$

Where: IZRF25 = Zener Diode Reference Current at 25°C - Amperes

CURZ = Input Table of IZRF25 as a function of HDZMX

Step 202 Calculate TC Zener Reference Voltage

$$VZRF25 = PZRF25 / IZRF25$$

Where: VZRF25 = TC Zener Reference Voltage at 25°C - VDC

Step 203 Calculate TC Zener Breakdown Voltage Ratio

$$\text{RATVB} = F \{ \text{TCZ}, \text{RATI} \}$$

at: $\text{RATI} = 0.0$

$$\text{RATI} = \text{TCZIV} \{ \text{RATV}, \text{TCZ} \}$$

Where: $\text{RATV} = \text{Zener Diode Voltage Ratio}$

$\text{RATI} = \text{Zener Diode Current Ratio}$

$\text{TCZIV} = \text{Input Table of RATI as a function of RATV and TCZ}$

$\text{RATVB} = \text{Zener Breakdown Voltage Ratio}$

Step 204 Calculate TC Zener Breakdown Voltage

$$\text{VZBR} = \text{RATVB} * \text{VRF25}$$

Step 205 Calculate Zener Diode Temperature at Breakdown

$$\text{TZBR} = \text{TCZ}$$

Where: $\text{TZBR} = \text{Zener Diode Temperature at Breakdown Voltage} - ^\circ\text{C}$

Step 206 Calculate Total Weight of Shunt Limiter

$$\text{DWDNZ} = \text{DWDNZT} \{ \text{PRF25}, \text{ISH} \}$$

$$\text{NZN} = \text{NZN} * \text{NESP}$$

$$\text{WSL} = \text{DWDNZ} * \text{FLOAT}(\text{NZN})$$

Where: $\text{DWDNZ} = \text{Zener Diode Specific Weight} - \text{Lbs/Zener}$

$\text{NZN} = \text{Total Number of Zener Diodes}$

$\text{DWDNZT} = \text{Input Table of DWDNZ as a function of PRF25 and ISH}$

Step 207 Calculate Total Cost of Shunt Limiter

$$NZTP = NZTOT * NSAP$$

$$DCDNZ = DCDNZT \{PRF25, NZTP, ISH\}$$

$$CSL = DCDNZ * FLOAT(NZTOT)$$

Where: NZTP = Total No. of Zener Diodes Procured

DCDNZ = Zener Diode Specific Cost - \$/Zener

DCDNZT = Input Table of DCDNZ as a function of PRF25, NZTP and ISH

GO TO STEP 215

Step 208 Calculate Power Source Group Type

$$IPSG = 0$$

Step 209 Calculate Shunt Limiter Reference Temperature

$$TSHREF = TSACMN$$

Where: TSHREF = Shunt Limiter Reference Temperature

Step 210 Calculate Active Shunt Limiter Impedance

$$ZSH = ZSHTAB \{TSH\}$$

$$\text{at: } TSH = TSHREF$$

Where: ZSH = Active Shunt Limiter Dynamic Impedance - Ohms

ZSHTAB = Input Table of ZSH as a function of TSH

Step 211 Calculate Active Shunt Limiter Turn-On Voltage

$$VSHTOR = VSLOP - XISLOP * ZSH$$

Where: VSHTOR = Shunt Limiter Turn-on Voltage - VDC at TSHREF

Step 212 Calculate Active Shunt Limiter Load

$$PSL = PPSGMX$$

Where: PSL = Active Shunt Limiter Load - Watts

Step 213 Calculate Shunt Limiter Weight

$$DWDPS = DWDPST \{PSL\}$$

$$WSL = DWDPS * PSL$$

Where: DWDPS = Shunt Limiter Specific Weight - Lbs/Watt

Step 214 Calculate Total Cost of Shunt Limiter

$$NSLP = NSAP$$

$$DCDPS = DCDPST \{PSL, NSLP\}$$

$$CSL = DEDPS * PSL$$

Where: NSLP = No. of Active Shunt Limiters Procured

DCDPS = Active Shunt Limiter Specific Cost - \$/Watt

DCDPST = Input Table of DCDPS as a function of PSL and NSLP

Step 215 Calculate Total Power System Weight

$$WPWR = WSA + WBATT + WCHG + WSL$$

Where: WPWR = Total Power System Weight - lbs

Step 216 Calculate Total Power System Cost

$$CPWR = CSA + CBATT + CCHG + CSL$$

Where: CPWR = Total Power System Cost - \$

Step 217 Print Design Synthesis Output Information

Step 218 Set Performance Analysis Battery Parameters

CB = CBD

XN = FLOAT(NCELL)

XICHMX = ZICHMX

RETURN TO MAIN PROGRAM

3.1 Terminator Characteristics

The Terminator Characteristics routine is used to calculate the sunrise and sunset times for a specific day of the year. The equations use solar vector location angles, time zone number, and buoy latitude and longitude to determine terminator hour angles and times.

PROGRAM ALGORITHMS

Step 1 Obtain Exact Date

DATE = Date; Days from the start of the year (1,365)

Step 2 Calculate Solar Vector Location in Equatorial Plane

ALPHEQ = OMEGA * DATE

Where: ALPHEQ = Solar Vector Location - Radians

OMEGA = (2 * π)/365.242

π = 3.14159

Note: There are 365.242 days per tropical year as measured from Vernal Equinox to Vernal Equinox

Step 3 Calculate Solar Radiation Variables

VAR(I) = FA0(I) + FA1(I) * COS(ALPHEQ) + ...
 + FA2(I) * COS(2.0 * ALPHEQ) + ...
 + FA3(I) * COS(3.0 * ALPHEQ) + ...
 + FB1(I) * SIN(ALPHEQ) + ...
 + FB2(I) * SIN(2.0 * ALPHEQ) + ...
 + FB3(I) * SIN(3.0 * ALPHEQ)

DECL = VAR(1) * π /180.0

ET = VAR(2)

Where: DECL = Solar Declination Angle - Radians

ET = Equation of Time Difference - Hours

FA, FB = Fourier Coefficients obtained from input data tables "Solar Radiation Fourier Coefficients"

Step 3a Calculate Solar Radiation Variables

IF: ITAPE = 0,
THEN: APPSC = VAR(3) * 3.1524808, and,
THEN: ATMEXC = VAR(4), and,
THEN: SDF = VAR(5)

Where: APPSC = Apparent Solar Constant - Watts/Meter²
(at AMO)

ATMEXC = Atmospheric Extinction Coefficient - Air Mass⁻¹

SDF = Sky Diffuse Factor

Step 4 Obtain Buoy Latitude

THELAD = Buoy latitude - degrees $\left\{ \begin{array}{l} + \text{ North} \\ - \text{ South} \end{array} \right\}$

Step 5 Convert Buoy Latitude

THETLA = THELAD * $\pi/180.0$

Where: THETLA = Buoy Latitude - Radians

Step 6 Calculate Terminator Hour Angle

IF: [THETLA > ($\pi/2.0$) - DECL],
THEN: HOURT = π , AND, Go to Step 7

HOURT = ARCCOS (-1.0 * TAN (THETLA) * TAN (DECL))

Where: HOURT = Terminator Hour Angle - Radians

Step 7 Convert Terminator Hour Angle

HOURLA = HOURT * 12.0/ π

Where: HOURLA = Terminator Hour Angle - Hours

Step 8 Obtain Buoy Location Time Zone Number

TZN = Time Zone Number (Hours behind Greenwich Mean Time)

Step 9 Obtain Buoy Longitude

THELOD = Buoy Longitude - degrees $\left\{ \begin{array}{l} + \text{ West} \\ - \text{ East} \end{array} \right.$

Step 10 Calculate Time of Sunrise and Sunset at Buoy Location

SRT = 12.0 - HOURS - ET - TZN + (THELOD/15.0)

SST = 24.0 - SRT

Where: SRT = Sunrise Time - Hours

SST = Sunset Time - Hours

RETURN TO DESIGN SYNTHESIS DRIVER ROUTINE

3.2 Clear Day Solar Insolation

The Clear Day Solar Insolation routine is used to compute the intensity of solar radiation incident on the buoy solar array for a particular day and time. The insolation is calculated for a clear day (i.e., no cloud cover) using solar array tilt angles, buoy location hour angles, sky diffuse factor, clearness numbers, and surface reflectivity.

PROGRAM ALGORITHMS

Step 1 Obtain Geometrical and Temporal Information

TIMEH = Daily Time - Hours after Midnight - (0,24)

TZN = Buoy Location Time Zone Number - (Hours behind Greenwich Mean Time)

THELOD = Buoy Longitude - Degrees $\left\{ \begin{array}{l} + \text{ West} \\ - \text{ East} \end{array} \right.$

HOURT = Terminator Hour Angle - Radians

DECL = Solar Declination Angle - Radians

THETLA = Buoy Latitude - Radians $\left\{ \begin{array}{l} + \text{ North} \\ - \text{ South} \end{array} \right.$

Step 2 Calculate Buoy Location Hour Angle

BHOURL = $15.0 * (\text{TIMEH} - 12.0 + \text{TZN} + \text{ET}) - \text{THELOD}$

BHOURL = BHOURL * $\pi/180.0$

Where: BHOURL = Buoy Location Hour Angle - Degrees

BHOURL = Buoy Location Hour Angle - Radians

Step 3 Compare Buoy Location Hour Angle With Terminator Hour Angle (Test for Solar Occultation)

IF: $\text{ABS}(\text{BHOURL}) > \text{ABS}(\text{HOURT})$

THEN: GO TO STEP 23

Step 4

Calculate Direction Cosines of Direct Solar Radiation

$$\text{COS}(\text{THETZS}) = \text{COS}(\text{BHOURL}) * \text{COS}(\text{DECL}) * \text{COS}(\text{THETLA}) + \dots$$

$$\dots + \text{SIN}(\text{DECL}) * \text{SIN}(\text{THETLA})$$

$$\text{COS}(\text{THW}) = \text{COS}(\text{DECL}) * \text{SIN}(\text{BHOURL})$$

$$\text{IF: } \text{COS}(\text{BHOURL}) > \left\{ \frac{\text{TAN}(\text{DECL})}{\text{TAN}(\text{THETLA})} \right\},$$

$$\text{THEN: } \text{KS} = 1.0$$

$$\text{IF: } \text{COS}(\text{BHOURL}) < \left\{ \frac{\text{TAN}(\text{DECL})}{\text{TAN}(\text{THETLA})} \right\},$$

$$\text{THEN: } \text{KS} = -1.0$$

$$\text{COS}(\text{THS}) = \text{KS} * \left\{ [1 - \text{COS}(\text{THETZS})]^2 - [\text{COS}(\text{THW})]^2 \right\}^{0.5}$$

Where: THETZS = Angle between the local zenith and the solar Vector - Radians

THW, THS = Additional Direction Angles - Radians

Step 5

Calculate Solar Altitude

$$\text{SALT} = \text{ARCSIN}(\text{COS}(\text{THETZS}))$$

Where: SALT = Solar Altitude (Angle between the solar vector and the Horizontal, i.e., Earth's surface) - Radians

Step 6

Calculate Solar Azimuth

$$\text{IF: } \text{COS}(\text{THS}) > 0,$$

$$\text{THEN: } \text{SAZM} = \text{ARCSIN}(\text{COS}(\text{THW})/\text{COS}(\text{SALT})), \text{ AND GO TO STEP 7}$$

$$\text{IF: } \text{COS}(\text{THS}) < 0,$$

$$\text{THEN: } \text{SAZM} = \pi - \text{ARCSIN}(\text{COS}(\text{THW})/\text{COS}(\text{SALT}))$$

Where: SAZM = Solar Azimuth (Angle between the Solar Vector Projected onto the Horizontal Surface and the South-Pointing Vector on the Horizontal Surface) - Radians

Step 7

Obtain Clearness Number

CN = Clearness Number

= 0.7-9.9 for an industrial atmosphere

= 0.85-1.10 for non-industrial atmospheres

Step 8 Obtain Solar Radiation Variables

$APPSC = \text{Apparent Solar Constant at AMO} - \text{Watts/Meter}^2$
 $ATMEXC = \text{Atmosphere Extinction Coefficient} - \text{Air Mass}^1$
 $SDF = \text{Sky Diffuse Factor}$

Step 9 Calculate Intensity of Direct Normal Solar Radiation
$$QDN = APPSC * CN * EXP(-ATMEXC/COS(\theta_{ETZS}))$$

Where: $QDN = \text{Direct Normal Solar Radiation Intensity} - \text{Watts/Meter}^2$

Step 10 Obtain Solar Array Pointing Angles

$PHIAID = \text{Surface Tilt Angle from Horizontal} - \text{Degrees}$
 (Angle between local Zenith and Solar Array Normal)

$PHIAAD = \text{Surface Azimuth Angle from South} - \text{Degrees}$
 (Angle between South pointing vector and projection of array normal on horizontal surface)

{+ if West of South}
 {- if East of South}

Step 11 Convert Solar Array Pointing Angles
$$PHIAI = PHIAID * \pi/180.0$$

$$PHIAA = PHIAAD * \pi/180.0$$

Where: $PHIAI = \text{Surface Tilt Angle} - \text{Radians}$

$PHIAA = \text{Surface Azimuth Angle} - \text{Radians}$

Step 12 Calculate Direction Cosines of Array Normal

(Reference Axis: Vertical, Horizontal to West, Horizontal to South)

$$ETAA = \text{COS}(PHIAI)$$

$$ETAB = \text{SIN}(PHIAA) * \text{SIN}(PHIAI)$$

$$ETAC = \text{COS}(PHIAA) * \text{SIN}(PHIAI)$$

Where: $ETAA, ETAB, ETAC$ are Array Normal Direction Cosines

Step 13 Calculate Solar Array Tilt Angle

$$\begin{aligned} \text{COS(TILT)} &= \text{ETAA} * \text{COS(THETZS)} + \dots \\ &+ \text{ETAB} * \text{COS(THW)} + \dots \\ &+ \text{ETAC} * \text{COS(THS)} \end{aligned}$$

Where: TILT = Solar Array Tilt Angle - Radians
(Angle between Solar Vector and Solar Array Normal)

Step 14 Calculate Intensity of Direct Solar Radiation Incident on the Solar Array

$$\begin{aligned} \text{IF: } &\text{COS(TILT)} > 0.0, \\ \text{THEN: } &\text{QD} = \text{QDN} * \text{COS(TILT)} \\ \text{IF: } &\text{COS(TILT)} \leq 0.0, \\ \text{THEN: } &\text{QD} = 0.0 \end{aligned}$$

Where: QD = Direct Solar Radiation Incident on Solar Array - Watts/Meter²

Step 15 Calculate Sky Brightness

$$\text{BS} = \text{SDF} * \text{QDN} / (\text{CN} ** 2.0)$$

Where: BS = Sky Brightness - Watts/Meter²

Step 16 Obtain Horizontal Surface (Ground/Ocean) Reflectivity

REFLH = Horizontal Surface Reflectivity for Solar Radiation

Step 17 Calculate Horizontal Surface Brightness

$$\text{BG} = \text{REFLH} * (\text{BS} + \text{QDN} * \text{COS(THETZS)})$$

Where: BG = Horizontal Surface Brightness - Watts/Meter²

Step 18 Calculate Intensity of Horizontal Surface Diffuse Radiation Incident on Solar Array

$$\text{QDG} = \text{BG} * ((1 - \text{ETAA}) / 2.0)$$

Where: QDG = Horizontal Surface Diffuse Radiation Incident on Solar Array - Watts/Meter²

Step 19 Calculate Intensity of Sky Diffuse Radiation Incident on a Horizontal Solar Array

$$QDSH = QDN * SDF$$

Where: QDSH = Sky Diffuse Radiation Incident on a Horizontal Solar Array - Watts/Meter²

Step 20 Calculate Intensity of Sky Diffuse Radiation Incident on a Vertical Solar Array

$$YV = 0.45$$

IF: $\text{COS}(\text{TILT}) > (-0.20)$,

THEN: $YV = 0.55 + 0.437 * \text{COS}(\text{TILT}) + 0.313 * (\text{COS}(\text{TILT})^{**2.0})$

$$QDSV = QDN * (SDF * YV + (\text{REFLH} * (SDF + \text{COS}(\text{THETZS}))))/2.0$$

Where: QDSV = Sky Diffuse Radiation Incident on a Vertical Solar Array - Watts/Meter²

Step 21 Calculate Intensity of Sky Diffuse Radiation Incident on Solar Array

$$QDS = QDSV + (QDSH - QDSV) * \text{COS}(\text{SALT})$$

Where: QDS = Sky Diffuse Radiation Incident on Solar Array - Watts/Meter²

Step 22 Calculate Intensity of Total Clear Day Solar Insolation Incident on Solar Array

$$QDTC = QD + QDG + QDS$$

Where: QDTC = Total Clear Day Solar Radiation Incident on Solar Array - Watts/Meter²

Return to Design Synthesis Driver Routine

Step 23 Calculate Occultation Conditions for Solar Insolation

$$QDN = 0.0$$

$$QD = 0.0$$

$$QDG = 0.0$$

$$QDS = 0.0$$

$$QDTC = 0.0$$

Return to Design Synthesis Driver Routine

3.3 Solar Array Electrical Characteristics

The Solar Array Electrical Section is made up of the solar array, the solar array isolation diodes, and the power source series resistance. The characteristics of these elements are calculated for the environmental conditions in which the subsystem will operate and are then combined into a single solar array current-voltage curve. Performance data are stored for a single solar cell, for an isolation diode, and for the series resistance that is typical of those in the buoy solar array. The data are projected from the component level into the electrical configuration determined by the Design Synthesis driver program. Equations are also included to estimate performance when the array is mis-oriented from the sun vector and to estimate performance degradation due to cloud cover, temperature extremes, and environmental effects.

PROGRAM ALGORITHMS

<u>Step 1</u>	Obtain Elapsed Time From Start of Mission
	DATEM = Elapsed time from start of mission - days
<u>Step 2</u>	Obtain Current Degradation Factors for Solar Array
	CDEGA = Solar Array Current Degradation Factor Due to Fabrication Losses - Percent (from zero)
	CDEGB = Solar Array Current Degradation Factor Due to Terrestrial Performance Extrapolation Uncertainty - Percent (from zero)
<u>Step 3</u>	Calculate Current Degradation Factor Due to Environmental Effects
	CDEGC = SADEGC(DATEM)
	Where: CDEGC = Solar Array Current Degradation Factor Due to Environmental Effects - Percent (from zero)
	SADEGC = Table of Solar Array Input Current Degradation Due to the Environment (in Percent from zero) as a Function of DATEM

Step 4 Calculate Solar Array Current Degradation Factor

$$CDEG = \frac{1.0 * 10^6 - (100.0 - CDEGA) * (100.0 - CDEGB) * (100.0 - CDEGC)}{1.0 * 10^6}$$

Where: CDEG = Solar Array Current Degradation Factor -
Dimensionless

Step 5 Obtain Voltage Degradation Factor for Solar Array

VDEGA = Solar Array open circuit voltage degradation due to
temperature uncertainty - Percent (from zero)

Step 6 Calculate Voltage Degradation Factor Due to Environmental Effects

VDEGB = SADEGV(DATEM)

Where: VDEGB = Solar Array Open Circuit Voltage Degradation
Factor due to Environmental Effects -
Percent (from zero)

SADEGV = Table of Solar Array Open Circuit Voltage
Degradation due to the Environment (in percent
from zero) as a function of DATEM

Step 7 Calculate Solar Array Voltage Degradation Factor

$$VDEG = \frac{1.0 * 10^4 - (100.0 - VDEGA) * (100.0 - VDEGB)}{1.0 * 10^4}$$

Where: VDEG = Solar Array Voltage Degradation Factor -
Dimensionless

Step 8 Obtain Solar Cell Spectral Correction Factor

SPECOR = Solar Cell Spectral Correction Factor - Dimensionless
(Corrects for differences between Spectrum of Solar
Radiation Incident on Solar Cell and Spectral Response
of Solar Cell)

Step 9 Obtain Total Solar Radiation

QDT = Total Solar Radiation Incident on Solar Array -
Watts/Meter²

- Step 10 Calculate Effective Solar Insolation
- $$X = \text{SPECOR} * \text{QDT}/10.0$$
- Where: X = Effective Solar Insolation Incident on Solar Cell - Milliwatts/cm²
- Step 11 Calculate Modified Solar Insolation
- $$XX = X * (1.0 - \text{CDEG})$$
- Where: XX = Modified Solar Insolation - mw/cm²
- Step 12 Obtain Single Solar Cell Area
- $$\text{ACELL} = \text{Single Solar Cell Area} - \text{cm}^2$$
- Step 13 Obtain Solar Array Temperature
- $$\text{TSAC} = \text{Solar Array Temperature} - ^\circ\text{C}$$
- Step 14 Calculate Short Circuit Current Temperature Coefficient for a Single Solar Cell
- $$\text{ALPHAC} = (7.428 * 10^{-7} - (1.83 * 10^{-9}) * \text{TSAC} * (\text{XX}) * \text{ACELL}/4.0$$
- Where: ALPHAC = Short Circuit Current Temperature Coefficient - Amperes/°C-cell
- Step 15 Calculate Solar Cell Series Resistance
- $$\text{RCELLC} = \text{F}[\text{RSCCELL}, \text{TEMTAB}] \text{ at } \text{TEMTAB} = \text{TSAC}$$
- Where: RCELLC = Solar Cell Series Resistance - Ohms (at Temperature TSAC)
- RSCCELL = Internal Table of Solar Cell Series Resistance as a function of Cell Temperature
- TEMTAB = Internal Table of Temperature Range Associated with RSCCELL

Step 16 Calculate Solar Cell I-V Curve Correction Factor

$$ROCELL = F[ROE, SUNLIT] \text{ at } SUNLIT = XX$$

Where: ROCELL = Solar Cell I-V Curve Correction factor at Solar Insolation Level: XX

ROE = Internal Table of Solar Cell I-V Curve Correction Factor as a Function of Solar Insolation

SUNLIT = Internal Table of Solar Insolation Range Associated with ROE

Step 17 Calculate Open Circuit Voltage Temperature Coefficient for a Single Solar Cell

$$BETAA = F [BETAB(\text{or } BETAC \text{ or } BETAD)] \text{ at } XX \text{ and } TSAC$$

$$BBETA = BETAA / 1000.0$$

Where: BBETA = Open Circuit Voltage Temperature Coefficient - (Volts/°C) at XX and TSAC

BETAA = Open Circuit Voltage Temperature Coefficient - (mv/°C) at XX and TSAC

BETAB, BETAC, BETAD = Internal Tables of Solar Cell Open Circuit Voltage As a Function of Solar Insolation and Cell Temperatures

SUNMW, SONMW, SENMW = Internal Tables of Solar Insolation Ranges Associated with (BETA) Tables

BTEMP, CTEMP, DTEMP = Internal Tables of Solar Cell Temperature Ranges Associated with (BETA) Tables

Internal Tables BTEMP, SUNMW AND BETAB used when:

$$(100 \leq XX \leq 540 \text{ mw/cm}^2) \text{ and } (-60 \leq TSAC \leq 160^\circ\text{C})$$

Internal Tables CTEMP, SONMW, BETAC used when:

$$(5 \leq XX \leq 253 \text{ mw/cm}^2) \text{ and } (-40 \leq TSAC \leq 60^\circ\text{C})$$

Internal Tables DTEMP, SENMW, BETAD used when:

$$(5 \leq XX \leq 100 \text{ mw/cm}^2) \text{ and } (-140 \leq TSAC \leq -40^\circ\text{C})$$

Step 18 Obtain Single Cell ISC, VOC Data

IISC = Solar Cell Short Circuit Current - Amperes/cell
(at 145 mw/cm² Solar Insolation and 60°C)

VVOC = Solar Cell Open Circuit Voltage - Volts/cell
(at 145 mw/cm² Solar Insolation and 60°C)

Step 19 Calculate ISC, VOC Shift Due to Degradation

C1 = CDEG * IISC

C2 = VDEG * VVOC

Where: C1 = Solar Cell Short Circuit Current Shift - Amps/cell

C2 = Solar Cell Open Circuit Voltage Shift - Volts/cell

Step 20 Obtain Single Circuit (of Solar Cells) Arrangement

NS = No of Solar Cells in Series in Each Circuit

NP = No of Solar Cells in Parallel in Each Circuit

Step 21 Calculate Cell Electrical Circuit Parameters

ALPHA = ALPHAC * NP

BETA = BBETA * NS

RCELL = (0.114 + RCELLC) * NS/NP

RHO = ROCELL * NS/NP

Where: ALPHA = Short Circuit Current Temperature
Coefficient for a Single Circuit -
Amperes/°C-circuit

BETA = Open Circuit Voltage Temperature
Coefficient for a Single Circuit -
Volts/°C

RCELL = Single Circuit Series Resistance - Ohms

RHO = Series Resistance Temperature Correction
Factor

Step 22 Calculate Modified Electrical Circuit Short Circuit Current

$$ISC = IISC * NP * (1.0 - CDEG)$$

Where: ISC = Modified Electrical Circuit Short Circuit Current - Amperes/circuit

Step 23 Calculate Short Circuit Current Difference (for an Electrical Circuit)

$$DISC = ISC * ((X/145.0) - 1.0) + ALPHA * (TSAC - 60.0)$$

Where: DISC = Short Circuit Current Difference due to current degradation, solar insolation changes and temperature changes - Amperes/circuit

Step 24 Calculate Electrical Circuit Voltage and Series Resistance Correction Factors

$$C3 = BETA * (TSAC - 60.0) + DISC * RCELL$$

$$C4 = RHO * (TSAC - 60.0)$$

Where: C3 = Electrical Circuit Voltage Correction Factor - Volts/circuit

C4 = Electrical Circuit Series Resistance Correction Factor - Ohms

Step 25 Obtain Reference Solar Cell Current-Voltage Characteristics

$I(J) = \text{Reference Solar Cell Current Data point - Amperes}$
 $V(J) = \text{Reference Solar Cell Voltage Data point - Volts}$

} Internal Tables

Where: J = 1,30

Step 26 Calculate Solar Cell Electrical Circuit Current-Voltage Characteristics

$$I(J) = NP * (II(J) - C1) + DISC$$

$$V(J) = NS * (VV(J) - C2) - C3 - (C4 * I(J))$$

Step 26 (contd)

Where: $J = 1,30$

$I(J)$ = Electrical Circuit Current - Amperes at the given level of $V(J)$

$V(J)$ = Electrical Circuit Voltage - Volts

Step 27 Obtain Solar Array Voltage Increment

VSAINC = Solar Array Voltage Increment - volts

Step 28 Redefine Electrical Circuit Current - Voltage Array in Selected Voltage Increments as follows:

a) Set: Counter $L = 1$ and voltage $V2(L) = 0.0$

b) Establish: Current $I1(L)$ at $V2(L)$

$I1(L) = F \{I(J), V(J)\}$ at $V(J) = V2(L)$

c) Increment: Counter $L = L + 1$ and voltage $V2(L + 1) = V2(L) +$
VSAINC and Establish: Current $I1(L + 1)$ at
 $V2(L + 1)$,

Until: $I1(L + 1) \leq 0.0$

d) Redefine: Last $V2(L)$ at $I1(L) = 0.0$

$V2(L) = F \{I(J), V(J)\}$ at $I(J) = 0.0$

e) Set: Current-Voltage Matrix Dimension to last counter value: MFINAL = L

Step 29 Obtain Number of Solar Cell Electrical Circuits in Solar Array

NESP = Number of Electrical Circuits in Solar Array
(assumed in parallel)

Step 30 Calculate Solar Array Current-Voltage Characteristics

$$I2(L) = (I1(L) * NESP) \text{ at } V2(L)$$

$$L = 1, MFINAL$$

Where: $I1(L)$ = Electrical Circuit Current - Amperes at $V2(L)$

$I2(L)$ = Solar Array Current - Amperes at $V2(L)$

$V2(L)$ = Circuit or Array Voltage - Volts

Step 31 Obtain Voltage Data for Calculation of Solar Array Maximum Power Point

XV = Initial Voltage for Max Power Point Calculations - Volts

DXN = Voltage Increment for Maximum Power Point Calculation - Volts

Step 32 Initialize Calculation Value of Solar Array Maximum Power

$$MSAPWR = 0.0$$

Where: $MSAPWR$ = Solar Array Maximum Power - Watts

Step 33 Calculate Solar Array Power and Current

$$XI = F \{I2(L), V2(L)\} \text{ at } V2(L) = XV$$

$$SAPWR = XI * XV$$

Where: XV = Solar Array Voltage - Volts

XI = Solar Array Current - Amperes

$SAPWR$ = Solar Array Power - Watts

Step 34 Compare Solar Array Power With Maximum Power

IF: $SAPWR > MSAPWR$

THEN: $MSAPWR = SAPWR$

$$XV = XV + DXV$$

Repeat Step 33 until: $SAPWR \leq MSAPWR$

Step 35 Recalculate Solar Array Current and Power

$$\text{MSAPWR} = 0.0$$

$$\text{XV} = \text{XV} - \text{DXV}$$

REPEAT STEP 33 ONLY

Step 36 Compare Solar Array Power With Maximum Power

IF: - $\text{SAPWR} > \text{MSAPWR}$,
THEN: $\text{MSAPWR} = \text{SAPWR}$

$$\text{DXV} = \text{DXV}/10.0$$

$$\text{XV} = \text{XV} + \text{DXV}$$

REPEAT STEP 33 ONLY UNTIL: $\text{SAPWR} < \text{MSAPWR}$

Step 37 Calculate Solar Array Maximum Power Point Characteristics

$$\text{MAXV} = \text{XV} - \text{DXV}$$

$$\text{MAXI} = \text{MSAPWR}/\text{MAXV}$$

Where: MAXV = Solar Array Voltage at Max Power Point - Volts

MAXI = Solar Array Current at Maximum Power Point -
Amperes

RETURN TO DESIGN SYNTHESIS DRIVER ROUTINE

3.4 Power Conditioning and Distribution Group

The Power Conditioning and Distribution Group is made up of the lamp flasher and the housekeeping regulator. The characteristics of these two subassemblies are computed as a function of the selected lamp flasher pattern and the lamp flasher condition (on, off, or flashing). These characteristics are then shifted for the combined effects of wiring and connector series resistance to give a single set of current-voltage curves at the unregulated bus.

PROGRAM ALGORITHMS

Step 1 Obtain Flasher Pattern Type

IF: IFTYPE = 0,
THEN: GO TO STEP 3

Where: IFTYPE is the type of flasher pattern
= 0: Non-Standard Pattern
> 0: Standard Pattern

Step 2 Calculate Standard Flasher Pattern

TL1(J) = TLO {IFTYPE, J}

$(1 < \text{IFTYPE} < 15)$
 $(1 \leq J \leq 16)$ } 15 standard pattern types
Up to 16 steps per pattern
Alternate On/Off steps

GO TO STEP 4

Where: TLO is an input table containing TL1 as a function of IFTYPE and J

TL1 = Selected Lamp Flasher Pattern

Step 3 Calculate Non-Standard Flasher Pattern

TL1(J) = TLL1(J) $(1 \leq J \leq 16)$

Where: TLL1(J) is the input data containing up to 16 alternate on-off steps for the Non-Standard Flasher Pattern

Step 4 Calculate Total Duration of Lamp Illumination and Lamp Shut-Off

$$TLON = \sum_{J=1,3,5\dots}^{15} [TL1(J)]$$

$$TLOFF = \sum_{J=2,4,6\dots}^{16} [TL1(J)]$$

Where: TLON = Total duration of lamp illumination
 TLOFF = Total duration of lamp shut-off

{ in a single
 { flasher period

IF: TLON \leq 0, and; TLOFF \leq 0

THEN: Stop program and

Print: "No flasher pattern entries"

Step 5 Calculate Lamp Duty Cycle

$$DL = TLON / (TLON + TLOFF)$$

Where: DL = Lamp Duty Cycle

Step 6 Obtain Lamp Characteristics

VLR = Lamp Voltage Rating - VDC

ILR = Lamp Current Rating - Amperes

CLS = Cold-Filament Lamp Surge Coefficient

Step 7 Calculate Actual Lamp Current

$$IL = CLS * ILR$$

Where: IL = Actual Lamp Current - Amperes

Note: If DL = 1.0 then CLS = 1.0
 If DL < 1.0 then CLS > 1.0

Step 8 Calculate Actual Lamp Resistance

$$RL = \frac{VLR}{IL}$$

Where: RL = Actual Lamp Resistance - Ohms

Step 9 Calculate Average Lamp Current

$$\overline{IL} = IL * DL$$

Where: \overline{IL} = Average Lamp Current - Amperes

Step 10 Calculate Effective Lamp Resistance

$$\overline{RL} = VLR / (\overline{IL})$$

Where: \overline{RL} = Effective Lamp Resistance - Ohms

Step 11 Obtain Raw Power Bus Voltage Limits and User Load Cable Resistance

VMINIV = Minimum Raw Power Bus Voltage - VDC

VMAXIV = Maximum Raw Power Bus Voltage - VDC

RLL = User Load Cable Resistance - Ohms

Step 12 Calculate PCD Group Voltage Increment

$$VINCIV = (VMAXIV - VMINIV) / 50.0$$

Where: VINCIV = PCD Group Voltage Increment - VDC

Step 13 Obtain PCD Equipment Temperature Characteristics

TTAMB = Ambient Temperature - °F

DTTPCD = PCD Equipment Temperature Rise - °F

Step 14 Calculate PCD Equipment Temperature

$$TTPCD = TTAMB + DTTPCD$$

Where: $TTPCD = \text{PCD Equipment Temperature} - ^\circ\text{F}$

Step 15 Compare Raw Power Bus Minimum Voltage With Reference

$$VRIO = \text{VRIOT} \{TTPCD\}$$

$$VRISA = \text{VRISAT} \{TTPCD\}$$

IF: $V_{MINIV} < VRIO$,
THEN: GO TO STEP 16

IF: $(V_{MINIV} > VRIO)$, And: $(V_{MINIV} \leq VRISA)$,
THEN: Go to Step 24

IF: $V_{MINIV} > VRISA$,
THEN: GO TO STEP 29

Where: $VRIO = \text{Minimum (No Current) Voltage Drop} - \text{VDC}$
 Across Lamp Regulator in "Saturated"
 Condition

$VRISA = \text{Voltage level at which lamp regulator} - \text{VDC}$ changes
 from "Saturated" condition operation to "Active"
 operation

$VRIOT = \text{Input Table of } VRIO \text{ as a function of } TTPCD$

$VRISAT = \text{Input Table of } VRISA \text{ as a function of } TTPCD$

Step 16 Initialize Counter and Lamp Regulator Voltage

$$J = 1$$

$$VRI(J) = V_{MINIV}$$

Step 17 Calculate Lamp Regulator Current

$$IRI(J,1) = 0.0$$

$$IRI(J,2) = 0.0$$

$$IRI(J,3) = 0.0$$

Step 17 (Contd)

Where: $VRI(J)$ = Lamp Regulator Input Voltage - VDC

$IRI(J,K)$ = Lamp Regulator Input Current - Volts

When: K=1 - Lamp Off
 K=2 - Lamp Flashing - Effective
 K=3 - Lamp On

Step 18 Increment Counter and Lamp Regulator Voltage and Compare With Reference

$J = J + 1$

$VRI(J) = VRI(J-1) + VINCIV$

IF: ($VRI(J) > VRIO$) And:

IF: ($VRI(J) < VMAXIV$)

THEN: GO TO STEP 20

IF: $VRI(J) > VMAXIV$

THEN: GO TO STEP 32

Step 19 Calculate Lamp Regulator Currents

$IRI(J,1) = 0.0$

$IRI(J,2) = 0.0$

$IRI(J,3) = 0.0$

REPEAT STEPS 18 AND 19

Step 20 Calculate Lamp Regulator Current

$IRI(J,1) = 0.0$

$IRI(J,2) = (VRI(J) - VRIO) / (\overline{RL} + ZRS)$

$IRI(J,3) = (VRI(J) - VRIO) / (RL + ZRS)$

Where: ZRS = Regulator Impedance in "Saturated" Condition - Ohms

ZRS = ZRST (TTPCD)

ZRST = Input Table of ZRS as a function of TTPCD

Step 21 Increment Counter and Lamp Regulator Voltage and Compare with Reference

$J = J + 1$

$VRI(J) = VRI(J - 1) + VINCIV$

IF: $(VRI(J) > VRISA)$ AND:

IF: $(VRI(J) < VMAXIV)$

THEN: Go to Step 22

IF: $VRI(J) > VMAXIV$

THEN: GO TO STEP 32

REPEAT STEPS 20 AND 21

Step 22 Calculate Lamp Regulator Currents

$VLB = VLBT \{VRI, TTPCD\}$

$ZRA = ZRAT \{TTPCD\}$

$IRI(J,1) = 0.0$

$IRI(J,2) = V_{LB} / (\overline{RL} + ZRA)$

$IRI(J,3) = V_{LB} / (RL + ZRA)$

Where: V_{LB} = Regulator Output Voltage at Zero Current - Volts

ZRA = Regulator impedance in "Active" region - Ohms

$VLBT$ = Input Table of VLB as a function of VRI and $TTPCD$

$ZRAT$ = Input Table of ZRA as a function of $TTPCD$

Step 23 Increment Counter and Lamp Regulator Voltage and Compare With Reference

$J = J + 1$

$VRI(J) = VRI(J - 1) + VINCIV$

IF: $VRI(J) > VMAXIV$

THEN: GO TO STEP 32

REPEAT STEPS 22 AND 23

Step 24 Initialize Counter and Lamp Regulator Voltage

$J = 1$

$VRI(J) = VMINIV$

Step 25 Calculate Lamp Regulator Currents

$IRI(J,1) = 0.0$

$IRI(J,2) = (VRI(J) - VRIO) / (\overline{RL} + ZRS)$

$IRI(J,3) = (VRI(J) - VRIO) / (RL + ZRS)$

Step 26 Increment Counter and Lamp Regulator Voltage and Compare with Reference

$J = J + 1$

$VRI(J) = VRI(J - 1) + VINCIV$

IF: $(VRI(J) > VRISA)$, AND:

IF: $(VRI(J) < VMAXIV)$

THEN: GO TO STEP 27

IF: $VRI(J) > VMAXIV$

THEN: GO TO STEP 32

REPEAT STEPS 25 AND 26

Step 27 Calculate Lamp Regulator Currents

$IRI(J,1) = 0.0$

$IRI(J,2) = VLB / (\overline{RL} + ZRA)$

$IRI(J,3) = VLB / (RL + ZRA)$

Step 28 Increment Counter and Lamp Regulator Voltage and Compare with Reference

$$J = J + 1$$

$$VRI(J) = VRI(J - 1) + VINCIV$$

IF: $VRI(J) > VMAXIV$

THEN: GO TO STEP 32

REPEAT STEPS 27 AND 28

Step 29 Initialize Counter and Lamp Regulator Voltage

$$J = 1$$

$$VRI(J) = VMINIV$$

Step 30 Calculate Lamp Regulator Currents

$$IRI(J,1) = 0.0$$

$$IRI(J,2) = VLB / (\overline{RL} + ZRA)$$

$$IRI(J,3) = VLB / (RL + ZRA)$$

Step 31 Increment Counter and Lamp Regulator Voltage and Compare with Reference

$$J = J + 1$$

$$VRI(J) = VRI(J - 1) + VINCIV$$

IF: $VRI(J) > VMAXIV$

THEN: Go to Step 32

REPEAT STEPS 30 AND 31

Step 32 Calculate PCD Group Current

$$IHI(J) = IHIT \{VRI(J), TTPCD\}$$

$$XI(J,K) = IHI(J) + IRI(J,K)$$

for: $J = 1, 50; K = 1, 3$

Step 32 (contd)

Where: $XI(J,K)$ = PCD Group Current - Amperes

$IHI(J)$ = Housekeeping Load Regulator Input Current -
Amperes

$IHIT$ = Input Table of $IHI(J)$ as a function of $VRI(J)$
and $TTPCD$

Step 33 Calculate PCD Group Voltage

$XX(J,K) = VRI(J) + XI(J,K) * RLL$

for: $J = 1,50; K = 1,3$

Where: $XX(J,K)$ = PCD Group Voltage - VDC

4. PERFORMANCE ANALYSIS

The Performance Analysis segment of the DSPA program uses known power system arrangements, electrical sizes, and physical characteristics to determine the response (operational characteristics) of the equipment to a given stimulus (load and environmental profiles). A block diagram of the Performance Analysis driver program is shown in Figure 4.1. As shown, the object of the performance analysis methodology is to obtain the raw power bus operating point for each time increment during a mission period. Once this operating point is obtained, all power system operational characteristics are determinable.

To obtain the operating point, the power system is divided into groups. These groups and the equipment comprising them are:

- a. Power Source Group:
 - 1) Solar Array.
 - 2) Shunt Limiter.
 - 3) Solar Array Isolation Diodes.
 - 4) Solar Array Cable.
- b. Energy Storage Group:
 - 1) Batteries.
 - 2) Battery Chargers.
 - 3) Battery Isolation Diodes.
 - 4) Battery Cables.
- c. Power Conditioning and Distribution Group:
 - 1) User Loads.
 - 2) Load Cable.

Current-voltage (I-V) characteristics are determined for each equipment group. The Power Conditioning and Distribution Group characteristics are then deducted from those of the Power Source Group to obtain a Difference Curve. The intersection of the Difference Curve with the

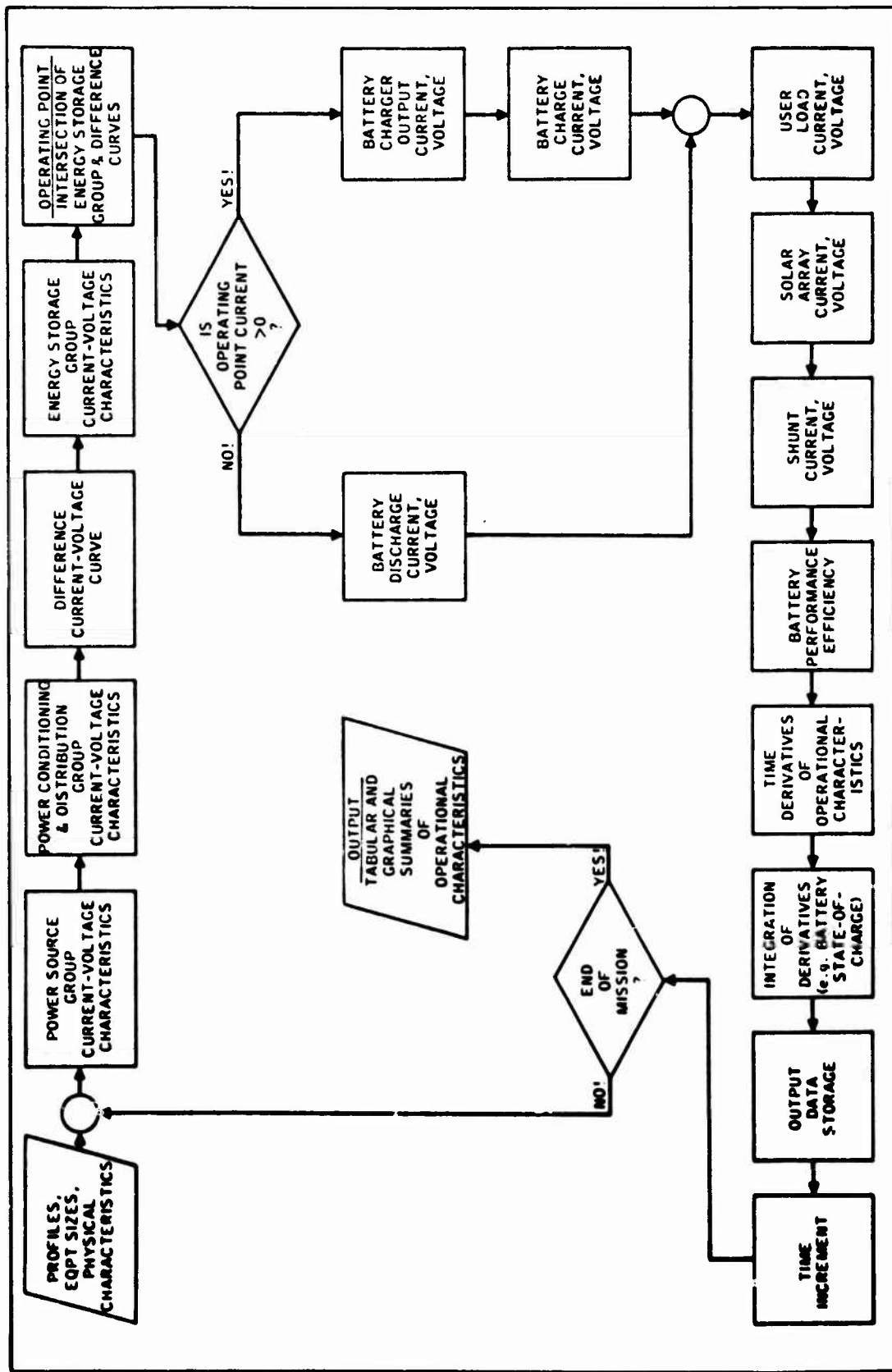

FIGURE 4-1. POWER SYSTEM PERFORMANCE ANALYSIS

Energy Storage Group characteristics is an estimate of the voltage and current on the raw power bus (operating point). During the time increment under examination, the battery is in a state-of-charge, discharge, or open-circuit depending on the value and sign of the operating point current.

After the operating point is obtained, the operational characteristics of the power system equipment are determined. The computer program is then ready for examination of power system response for the next time increment. The process is repeated until the end of the mission period.

PROGRAM ALGORITHMS

Step 1 Obtain Pertinent Mission and Equipment Information

QON = Solar Insolation Level for Lamp Flasher Turn-On -
Watts/Meter²

QOFF = Solar Insolation Level for Lamp Flasher Turn-Off -
Watts/Meter²

ISH = Shunt Limiter Type

Where: 0 = None

1 = Ordinary Zener Diode

2 = Temperature Compensated Zener Diode

3 = Active Shunt Limiter

VBUSI = Initial Estimate of Power System Operating Point Voltage at
Raw Power Bus - VDC

Step 2 Obtain Free Format Data Read-In Card Type

NCTYPE = Free Format Card Type

Where: 0 = Start-Up Data

1 = Time-Variant Data

<0 = Termination Data

IF: NCTYPE = 0
THEN: GO TO STEP 3

IF: NCTYPE = 1
THEN: GO TO STEP 6

IF: NCTYPE < 0
THEN: Terminate Performance Analysis Calculations and return to
main program

Step 3: Obtain Free Format Start-Up Data

START = Starting "Time" of Computer Run - YYDDHMM

Where: YY = Year {00-99}

DDD = Date {001-365} days from beginning of the year

HH = Hours {00-24} Hours after Midnight

MM = Minutes {00-60} minutes after the hour

Step 3 (Contd)

HLLA = Nominal Time Increment for Performance Analysis
Calculations - hours (Default value = 1.0 hours)

ACCQB = Battery State-of-Charge Accuracy Requirement for the
Predictor-Corrector Routine - (Default value = 0.01)

CT = Cloud Type (at Start-Up)

0.0 = Cirrus or Cirrostratus Clouds

1.0 = Stratus Clouds

2.0 = Other Cloud Types

TC = Cloud Cover (at Start-Up)

0.0 = No Cloud Cover

(0.0 < TC ≤ 10.0) = Tenths of Sky Covered by Clouds

INDFLS = Lamp Flasher Condition Indicator

0 = Lamp Flasher Off (Lamp Not Flashing)

1 = Lamp Flasher On (Lamp Flashing)

Step 4 Calculate Starting "Time" Information for Computer Run

YEAR = YY {00-99} - Year

DATE = DDD {001-365} - Days from beginning of year

TIMEH = HH + $\frac{MM}{60.0}$ - Hours after Midnight

DATEM = 0.0 - Elapsed Time Since "Start" of Computer run - days

Step 5 Initialize "Starting" Time Reference Data

YEAR1 = YEAR

DATE1 = DATE

DATEM1 = DATEM

Go To Step 10

Step 6 Obtain Free Format Time-Varying Data

DURA = Duration of a Significant Time Interval (\equiv DDDHHMM)

Where: DDD = Days (\geq 000)

HH = Hours (\geq 00)

MM = Minutes (\geq 00)

NTS = Number of time steps during Significant Time Interval (DURA)
for printing out Performance Analysis Data

CT = Cloud Type (During Significant Time Interval)

TC = Cloud Cover (During Significant Time Interval)

Step 7 Initialize Time Step Counter and Durations of Various Intervals

LNTS = 1

DURAH = $(24.0) * DDD + HH + \left(\frac{MM}{60.0}\right)$

HINT = DURAH/NTS

Where: DURAH = Duration of a Significant time interval - Hours

HINT = Duration of a print-out time step - Hours
during a significant time interval

Step 7a Initialize Reference Value of Print-Out Time Step Duration

H2 = 0.0

Where: H2 = Reference Value of Print-Out Time Step Duration - Hours

Step 8 Calculate Performance Analysis Calculation Time Interval

H = AMIN (HLLA-H2, HINT)

Where: H = Performance Analysis Calculation Time Interval - Hours

Step 9 Calculate "Time" of Performance Analysis Calculation

DATEM = DATEM1 + (H/24.0)

DATE2 = DATE1 + (H/24.0)

TIMEH = (DATE2 - IFIX (DATE2)) * 24.0

DATE = IFIX (DATE2)

Step 9 (Contd)

IF: DATE > 365.0
THEN: DATE = DATE - 365.0, AND,
THEN: YEAR = YEAR1 + 1.0

Step 9a Initialize Low Insolation Load Selector

KLL = 3

Where: KLL = Load Selector at Low Values of Solar Insolation

1 = Lamp Off

3 = Lamp On

Step 10 Obtain Power Sources Group Characteristics at the Raw Power Bus

NESP = Number of Electrical Circuits in Solar Array

RSA = Solar Array Electrical Circuit Cable Resistance - Ohms

MSAPWR = Solar Array Maximum Power - Watts

QDT = Total Solar Insolation Incident on Solar Array -
 Watts/Meter²

SX(I) = Power Source Group Voltage - VDC

SY(I) = Power Source Group Current at SX(I) - Amperes

I = 1, NAPSG

Where: IF: ISH = 0; THEN: NAPSG = MFINAL

IF: ISH > 0; THEN: NAPSG = NFINAL

IF: QDT ≤ 0.0; THEN: NAPSG = KFINAL

MFINAL OR NFINAL are calculated as part of the Power Source Group current-voltage estimate

KFINAL is the maximum extent of the SX(I) and SY(I) arrays.

Step 11 Determine Lamp Flasher Condition

IF: QDT ≤ 0.0
THEN: INDFLS = 1 AND: KL = 2

IF: (0.0 < QDT ≤ QON)
THEN: INDFLS = 1 AND: FL = 3

IF: (QON < QDT < QOFF) AND: INDFLS = 0
THEN: INDFLS = 0 AND: KL = 1

Step 11 (Contd)

IF: (QON < QDT < QOFF) AND: INDFLS = 1

THEN: INDFLS = 1 AND: KL = 3

IF: QDT > QOFF

THEN: INDFLS = 0 AND: KL = 1

IF: NCTYPE = 0 AND: KL = 3

THEN: KL = 2

Where: KL = Load Selector Indicator

1 = Lamp Off (During Daylight)

2 = Lamp Flashing (At Night)

3 = Lamp Off/On (At Low Solar Insolation Levels)

Step 12 Determine Power Conditioning and Distribution Group Level Selector

IF: KL = 1

THEN: K = 1

IF: KL = 2

THEN: K = 2

IF: KL = 3 AND: KLL = 1

THEN: K = 3

Where: K = Power Conditioning/Distribution Group Load Selector

1 = Lamp Off

2 = Effective Load - Lamp Flashing

3 = Lamp On

Step 13 Obtain Power Conditioning and Distribution Group Characteristics at the Raw Power Bus

XX(J) = Power Conditioning and Distribution Group Voltage - VDC

XI(J) = Power Conditioning and Distribution Group Current at XX(J) - Amperes

J = 1,50 (Number of Data Points)

K = 1, 2, or 3 (See Above)

DL = Lamp Duty Cycle

Step 14 Rearrange Voltage Data into One Array in Ascending Order

DIFIV(L,1) = {F SX(I), and XX(J)}
(in ascending order)

I = 1, NAPSG

J = 1, 50

L = 1, (50 + NAPSG)

Where: DIFIV(L,1) = Difference Curve Voltages - VDC

Step 15 Calculate Difference Curve Current Values

DIFIV(L,2) = SY(I) - XI(J)

Where: DIFIV(L,2) = Difference Curve Current at Voltage Level
DIFIV(L,1) - Amperes

SY(I) and XI(J) are selected at voltage DIFIV(L,1)

Note: If DIFIV(L,1) are beyond the limits of one of the current arrays, then use extrapolation methods based on existing current data.

Step 16 Obtain Energy Storage Group Characteristics at the Raw Power Bus

ICHRT = Battery Charger Type

0 = No Charger

1 = Constant Voltage Charger with Current Limit

NBATT = Number of Batteries in Parallel

TRESLT(LY,1) = Energy Storage Group Voltage - VDC

TRESLT(LY,2) = Energy Storage Group Current - Amperes
at TRESLT(L,1)

IF: ICHRT = 0; THEN: LY = 1,9

IF: ICHRT = 1; THEN: LY = 1,10

CB = Maximum Discharge Capacity - Ampere-Hours
(for each Battery) at a standard discharge rate to a
standard terminal) voltage per cell at a standard
temperature.

Step 16 (Contd)

	<u>NiCd Batteries</u>	<u>Pb-Acid Batteries</u>
Standard Discharge Rate	c/2	c/20
Standard Min Cell Terminal Voltage	0.5	1.0
Standard Temperature	70°F	70°F

TTEG = Energy Storage Group Temperature - °F

QB = State of Charge of each battery - dimensionless

Step 17 Initialize Power System Operating Point

IF: NCTYPE = 0,
THEN: VBUS = VBUSI

Where: VBUS = Power System Voltage at Operating Point - VDC
(at Raw Power Bus)

Step 18 Calculate Current Difference

DELCUR = DIFIV(M,2) - TRESLT(M,2)

Where: DIFIV(M,2) = F(DIFIV(L,2), DIFIV(L,1)) at DIFIV(L,1) = VBUS

TRESLT(M,2) = F(TRESLT(LY,2), TRESLT(LY,1))
at TRESLT(LY,1) = VBUS

DELCUR = Difference in current level between difference
curve and energy storage group - Amperes

Step 19 Compare Current Difference with Reference and Calculate New Operating Point Voltage

IF: DELCUR \leq 0.0005 (Amperes)
THEN: Go to Step 20

VBUS2 = VBUS

VBUS = VBUS + DVBUS

VBUS3 = VBUS

Where: DVBUS = Increment added to operating point voltage estimate
by Newton-Raphson closure routine - VDC

VBUS2, VBUS3 = Estimates of VBUS

REPEAT STEPS 18 AND 19

Step 20 Determine Operating Point Stability

IF: SDIF < SESG
THEN: GO TO STEP 21

Where: SESG = Slope of the Energy Storage Group Current-Voltage Characteristics (TRESLT) at VBUS - Amperes/VDC

SDIF = Slope of the Difference curve (DIFIV) Current-Voltage Characteristics at VBUS - Amperes/VDC

VBSAVE = VBUS

Compare VBUS3 to VBUS2 and continue in the same general "direction" (from VBUS2 to VBUS3) with respect to voltage (by repeating steps 18, 19, 20) until a stable point is found or until the appropriate lower or upper voltage limits (based on Difference Curve Voltages) are reached. If no stable point is obtained, set VBUS = VBSAVE and repeat steps 18, 19, 20 in the opposite direction (relative to voltage) until a stable point is obtained or until the appropriate lower or upper voltage is reached.

If no stable operating point is estimated, then terminate run and print out the following information:

DIAGNOSTIC:

"RUN TERMINATED - NO STABLE OPERATING POINT"

"TRESLT(LY,1) ="

"TRESLT(LY,2) ="

LY = 1, 10 to (10 * NBATT)

"DIFIV(L,1) ="

"DIFIV(L,2) ="

L = 1, (50 + NAPSG)

Step 21 Calculate Energy Storage Group Current

XITT = DIFIV(M,2) at DIFIV(M,1) = VBUS

Where: XITT = Energy Storage Group Current - Amperes at VBUS

Step 22 Obtain Energy Storage Unit Current-Voltage Characteristics

TRESV(LY) = Energy Storage Unit Voltage - VDC

TRESI(LY) = Energy Storage Unit Current - Amperes
 at TRESV(LY)

IF: ICHRT = 0; THEN: LY = 1, 9

IF: ICHRT = 1; THEN: LY = 1, 10

Step 23 Calculate Battery Current

$$BCUR = F \{TRESI(LY), TRESV(LY)\} \text{ at } TRESV(LY) = VBUS$$

Where: BCUR = Current for each Battery - Amperes

+ \equiv Battery Charging

0 \equiv Battery Open Circuit

- \equiv Battery Discharging

Step 24 Obtain Battery Current-Voltage Characteristics

$$VG(LJ) = \text{Battery Potential} - \text{VDC}$$

$$XIB(LJ) = \text{Battery Current} - \text{Amperes} \\ \text{at } VB(LJ)$$

$$LJ = 1, 9 \text{ (Number of data points)}$$

Step 25 Calculate Battery Potential

$$VBAT = F\{VB(LJ), XIB(LJ)\} \text{ at } XIB(LJ) = BCUR$$

Where: VBAT = Potential of each battery - VDC

Step 26 Calculate Power Conditioning and Distribution Group Current

$$XIPCD = F \{XI(J), XX(J)\} \text{ at } XX(J) = VBUS$$

$$J = 1, 50 \text{ (data points)}$$

$$K = 1, 2 \text{ or } 3 \text{ (from Step 12)}$$

Where: XIPCD = Input Current to Power Conditioning and Distribution Group - Amperes

Step 27 Calculate Power Sources Group Current

$$XIPSG = F\{SY(I), SX(I)\} \text{ at } SX(I) = VBUS$$

$$I = 1, \text{ NAPSG}$$

Where: XIPSG = Power Sources Group Output Current - Amperes
at the Operating Point

Step 28 Obtain Shunt-Limiter Current-Voltage Characteristics at the Raw Power Bus

$$ZV(IZ) = \text{Shunt Limiter Voltage} - \text{VDC}$$

$$ZI(IZ) = \text{Shunt Limiter Current} - \text{Amperes} \\ \text{at } ZV(IZ)$$

$$IZ = 1, 20 \text{ (data points)}$$

Step 29 Calculate Shunt Limiter Current

$$XIZ = F\{ZI(IZ), ZV(IZ)\} \text{ at } ZV(IZ) = \text{VBUS}$$

Where: XIZ = Shunt Limiter Current at the operating point - Amperes

Step 30 Calculate Solar Array Current

$$XISA = XIZ + XIPSG$$

Where: $XISA$ = Solar Array Current - Amperes

Step 31 Calculate Solar Array Electrical Circuit Current

$$XIEC = XISA / \text{NESP}$$

Where: $XIEC$ = Solar Array Electrical Circuit Current - Amperes

Step 32 Calculate Solar Array Potential

$$\text{VDIODE} = \text{AD1} (XIEC)$$

$$\text{VSA} = \text{VBUS} + \text{VDIODE} + (XIEC * \text{RSA})$$

Where: VDIODE = Electrical Section Blocking Diode Voltage Drop at $XIEC$ - VDC

$$\text{VSA} = \text{Solar Array Potential} - \text{VDC}$$

$$\text{AD1} = \text{Input Table of VDIODE as a function of XIEC}$$

Step 33 Calculate Equipment Power Levels

$$\text{PESG} = |\text{VBUS} * \text{XITT}|$$

$$\text{PBATT} = |\text{VBAT} * \text{BCUR}|$$

$$\text{PPCD} = \text{VBUS} * \text{XIPCD}$$

$$\text{PPSG} = \text{VBUS} * \text{XIPSG}$$

$$\text{PSL} = \text{VBUS} * \text{XIZ}$$

$$\text{PSA} = \text{VSA} * \text{XISA}$$

Step 33 (Contd)

Where: PESG = Energy Storage Group Power - Watts

PBATT = Power Level of each Battery - Watts

PPCD = Power Conditioning and Distribution Group Power -
Watts

PPSG = Power Source Group Power - Watts

PSL = Shunt Limiter Power - Watts

PSA = Solar Array Power - Watts

Step 34 Calculate Equipment Power Margins

MARSA = MSAPWR - PSA

Where: MARSA = Solar Array Power Margin - Watts

Step 36 Initialize Battery Charge Efficiency

IF: NCTYPE = 0; THEN: ETA = 1.0

Where: ETA = Instantaneous Charge Efficiency for each Battery -
dimensionless

Step 37 Compare Battery Charge Efficiency With Reference

IF: $ETA \leq 0.0$; THEN: $ETA = 0.00001$; AND: Go To Step 42

Step 38 Compare Battery Current With Reference

IF: $BCUR < 0.0$; THEN: $ETA = 1.0$; AND: Go To Step 42

Step 39 Calculate Normalized Battery Charge Rate

$CHRN = BCUR/CB$

Where: CHRN = Normalized Battery Charge Rate - Hour⁻¹

Step 40 Calculate Instantaneous Battery Charge Efficiency

$ETA = A(TTESG, CHRN, QB)$

Where: A = A series of Input Data Tables (A1,A2,A3,A4,A5,A6) giving
instantaneous charge efficiency as a function of battery
temperature, normalized battery charge rate and battery
state-of-charge

Step 41 Compare Battery Charge Efficiency With Reference

IF: $ETA < 0.0$, THEN: $ETA = 0.00001$

Step 42 Calculate Rate of Charge of Battery State-of-Charge With Time

$$DQBDT = (BCUR * ETA) / CB$$

Where: $DQBDT =$ Rate of Charge of each Pattery State-of-Charge with
Time - Hours⁻¹

Step 44 Compare Card Type with Reference

IF: $NCTYPE = 0$;
THEN: $H = 0$; AND,
THEN: GO TO STEP 49

Step 45 Compare Load Selection Indicator With Reference and Determine Reference Calculation Interval

IF: $KL = 1$, OR,
IF: $KL = 2$,
THEN: GO TO STEP 49

IF: $KLL = 3$,
THEN: $H1 = H$

Where: $H1 =$ Performance Analysis Reference Calculation Interval -
Hours

Step 46 Compare Low Insolation Load Selector With Reference and Calculate Performance Analysis Calculation Interval

IF: $KLL = 1$
THEN: GO TO STEP 47

$$H = DL * H1$$

GO TO STEP 49

Step 47 Calculate Performance Analysis Calculation Interval

$$H = (1.0 - DL) * H1$$

Step 49 Calculate Battery State-of-Charge Increment

$$DELQB = H * DQBDT$$

Where: $DELQB =$ State-of-Charge Increment for each Battery

Step 51 Compare Card Type and Low Insolation Load Selector With References

IF: NCTYPE = 1, AND,
IF: KLL = 3,
THEN: GO TO STEP 57

Step 53 Calculate New Battery State-of-Charge

$$QB = QB + DELQB$$

Step 54 Calculate Battery Electrolyte Freezing Temperature

$$SPGR = SPGR1 (QB)$$

$$TBFRZ = TBFRZ1 (SPGR)$$

Where: SPGR = Electrolyte Specific Gravity for each Battery

TBFRZ = Electrolyte Freezing Temperature for each Battery - °F

SPGR1 = Input Table of SPGR as a function of QB

TBFRZ1 = Input Table of TBFRZ as a function of SPGR

Step 56 Compare Card Type With Reference

IF: NCTYPE = 0
THEN: GO TO STEP 2

GO TO STEP 63

Step 57 Calculate Battery State-of-Charge Relative Increment

$$DQB = ABS(DELQB/QB)$$

Where: DQB = State-of-Charge Relative Increment for each Battery

Step 59 Compare battery SOC Relative Increment With Reference

IF: $(H * ACCQB/DQB) \geq (HINT - H2 - 0.01)$
THEN: Go To Step 60

IF: $(DQB) < (0.7 * ACCQB)$, OR:

IF: $(DQB) > (ACCQB)$

THEN: $H = (H * ACCQB/DQB)$, AND:

THEN: RETURN TO STEP 9

Step 60 Calculate New Battery State-of-Charge

$$QB = QB + DELQB$$

Step 61 Calculate Battery Electrolyte Freezing Temperature

$$SPGR = SPGR1(QB)$$

$$TBFRZ = TBFRZ1(SPGR)$$

Step 62 Compare Load Selection Indicator and Low Insolation Load Selection With Reference and Calculate Low Insolation Load Selector

IF: KL = 3, AND,
IF: KLL = 3,
THEN: KLL = 1, AND
THEN: GO TO STEP 12

Step 62a IF: QB = 0
THEN: Print Error Message, AND
THEN: Return to Main Program

Step 63 Calculate Time Reference Data

$$DATEM1 = DATEM$$

$$DATE1 = DATE$$

$$TIMEH = 24.0 * (DATE1 - IFIX(DATE))$$

$$YEAR1 = YEAR$$

Step 64 Calculate Time Elapsed Since Last Print-Out

$$H2 = H2 + H$$

Step 65 Compare Elapsed Time With Duration of Time Until Next Print-Out

IF: H2 > HINT
THEN: Print Performance Analysis Output Information
THEN: GO TO STEP 66

RETURN TO STEP 8

Step 66 Increment Time Step Counter and Compare With Reference

$$LNTS = LNTS + 1$$

IF: LNTS > NTS
THEN: GO TO STEP 2

RETURN TO STEP 7a

4.1 Power Sources Group

The Power Source Group is made up of the solar array, the shunt limiter, the solar array isolation diodes, and the power source series resistance. The characteristics of these elements are calculated for the environmental conditions in which the subsystem is operated and are then combined into a single power source current-voltage curve at the unregulated bus. Performance data are stored for a single solar cell, for an isolation diode, for the specific shunting device to be used, and for the series resistance that are typical of those in the buoy solar array. The data are projected from the component level into the electrical configuration of the buoy solar array, and the program solves sets of equations that are designed to predict solar array/shunt limiter I-V characteristics at the unregulated bus. The Power Source Group program also includes equations to estimate the array performance when the array is misoriented from the sun vector and to estimate performance degradation due to cloud cover, temperature, and environmental effects.

PROGRAM ALGORITHMS

Step 1 Obtain the exact date and time of year

TIMEN = Daily Time - Hours after Midnight
Range of values: 0-24

DATE = Date - Days from start of the year
Range of Values: 1-365

Step 1a **IF:** ITAPE \neq 0
THEN: Obtain TTAMB from 'MERGE' file
THEN: GO TO STEP 5

Step 2 Obtain the Average Yearly Temperature

TTAVE = Average Yearly temperature in selected location - °F

Step 3 Calculate Average Daily Temperature

$$TTA = TTAVE + DTTA$$

Where: TTA = Average Daily Temperature - °F

DTTA = Average Daily Temperature Increment - °F

DTTA is obtained from input data in a table of average daily temperature increment as a function of the date, ie.,

$$DTTA = DTTA1(\text{DATE})$$

Step 4 Calculate Ambient Temperature

$$TTAMB = TTA + DTTAMB$$

Where: TTAMB = Ambient Temperature at selected location - °F

DTTAMB = Average hourly temperature increment at selected location - °F

DTTAMB is obtained from a table of Average hourly temperature increment as a function of the time, ie.,

$$DTTAMB = DTAMB1(\text{TIMEH})$$

Step 5 Obtain Power Source Group Equipment Temperature Characteristics

DTTPSG = Power Source Group Equipment Temperature Rise - °F

Step 6 Calculate Solar Array Temperature

$$TSAF = TTAMB + DTTPSG$$

Where: TSAF = Solar Array Temperature - °F

Step 7 Convert Solar Array Temperature

$$TSAR = TSAF + 459.67$$

$$TSAK = (5.0/9.0) * TSAR$$

$$TSAC = TSAK - 273.15$$

Where: TSAR = Solar Array Temperature - °R

TSAK = Solar Array Temperature - °K

TSAC = Solar Array Temperature - °C

Step 8 Calculate Solar Vector Location in Equatorial Plane

$$ALPHEQ = OMEGA * DATE$$

Where: ALPHEQ = Solar Vector Location - Radians

$$OMEGA = (2 * \pi) / 365.242$$

$$\pi = 3.14159$$

Note: There are 365.242 days per tropical year as measured from Vernal Equinox to Vernal Equinox

Step 9 Calculate Solar Radiation Variables

$$\begin{aligned} VAR(I) = & FA0(I) + FA1(I) * COS(ALPHEQ) + \dots \\ & + FA2(I) * COS(2.0 * ALPHEQ) + \dots \\ & + FA3(I) * COS(3.0 * ALPHEQ) + \dots \\ & + FB1(I) * SIN(ALPHEQ) + \dots \\ & + FB2(I) * SIN(2.0 * ALPHEQ) + \dots \\ & + FB3(I) * SIN(3.0 * ALPHEQ) \end{aligned}$$

Step 9 (contd)

$$\text{DECL} = \text{VAR (1)} * \pi/180.0$$

$$\text{ET} = \text{VAR (2)}$$

$$\text{APPSC} = \text{VAR (3)} * 3.1524808$$

$$\text{ATMEXC} = \text{VAR (4)}$$

$$\text{SDF} = \text{VAR (5)}$$

Where: DECL = Solar Declination Angle - Radians

ET = Equation of Time Difference - Hours

APPSC = Apparent Solar Constant - Watts/Meter²
(at AMO)

ATMEXC = Atmosphere Extinction Coefficient - Air Mass⁻¹

SDF = Sky Diffuse Factor

FA, FB = Fourier Coefficients obtained from input data
tables "Solar Radiation Fourier Coefficients"

Step 10 Obtain Buoy Latitude

$$\text{THELAD} = \text{Buoy latitude - degrees} \begin{cases} + \text{ North} \\ - \text{ South} \end{cases}$$

Step 11 Convert Buoy Latitude

$$\text{THETLA} = \text{THELAD} * \pi/180.0$$

Where: THETLA = Buoy Latitude - Radians

Step 12 Calculate Terminator Hour Angle

$$\text{IF: THETLA} \geq [(\pi/2.0) - \text{DECL}]$$

$$\text{THEN: HOURT} = \pi$$

Go to Step 13

$$\text{HOURT} = \text{ARCCOS} (-1.0 * \text{TAN} (\text{THETLA}) * \text{TAN} (\text{DECL}))$$

Where: HOURT = Terminator Hour Angle - Radians

Step 13 Convert Terminator Hour Angle

$$\text{HOURA} = \text{HOURT} * 12.0/\pi$$

Where: HOURA = Terminator Hour Angle - Hours

Step 14 Obtain Buoy Location Time Zone Number

TZN = Time Zone Number (Hours behind Greenwich Mean Time)

Step 15 Obtain Buoy Longitude

THELOD = Buoy Longitude - degrees $\left\{ \begin{array}{l} + \text{ West} \\ - \text{ East} \end{array} \right.$

Step 16 Calculate Time of Sunrise and Sunset at Buoy Location

$$\text{SRT} = 12.0 - \text{HOURA} - \text{ET} - \text{TZN} + (\text{THELOD}/15.0)$$

$$\text{SST} = 24.0 - \text{SRT}$$

Where: SRT = Sunrise time - Hours

SST = Sunset time - Hours

Step 17 Calculate Buoy Location Hour Angle

$$\text{BHOURL} = 15.0 * (\text{TIMEH} - 12.0 + \text{TZN} + \text{ET}) - \text{THELOD}$$

$$\text{BHOURL} = \text{BHOURL} * \pi/180.0$$

Where: BHOURL = Buoy Location Hour Angle - Degrees

BHOURL = Buoy Location Hour Angle - Radians

Step 18 Test for Solar Occultation

IF: ABS (BHOURL) \geq ABS (HOURT)

Go to Step 118

Step 19 Calculate Direction Cosines of Direct Solar Radiation

$$\text{COS (THETZS)} = \text{COS (BHOURL)} * \text{COS (DECL)} * \text{COS (THETLA)} + \dots \\ + \text{SIN (DECL)} * \text{SIN (THETLA)}$$

Step 19 (contd)

Where: THETZS = Angle between the local zenith and the solar vector - radians

$$\text{COS (THW)} = \text{COS (DECL)} * \text{SIN (BHOURL)}$$

$$\text{IF: COS (BHOURL)} > \left\{ \frac{\text{TAN (DECL)}}{\text{TAN (THETLA)}} \right\}$$

$$\text{THEN: KS} = 1.0$$

$$\text{IF: COS (BHOURL)} < \left\{ \frac{\text{TAN (DECL)}}{\text{TAN (THETLA)}} \right\}$$

$$\text{THEN: KS} = -1.0$$

$$\text{COS (THS)} = \text{KS} * \left\{ [1 - \text{COS (THETZS)}]^2 - [\text{COS (THW)}]^2 \right\}^{0.5}$$

Where: THW, THS = Additional Direction Angles - Radians

Step 20 Calculate Solar Altitude

$$\text{SALT} = \text{ARCSIN (COS (THETZS))}$$

Where: SALT = Solar Altitude (Angle between the solar vector and the Horizontal, i.e., Earth's surface) - Radians

Step 21 Calculate Solar Azimuth

$$\text{IF: COS (THS)} > 0$$

$$\text{THEN: SAZM} = \text{ARCSIN} [\text{COS (THW)}/\text{COS (SALT)}]$$

GO TO STEP 22

$$\text{IF: COS (THS)} < 0$$

$$\text{THEN: SAZM} = \pi - \text{ARCSIN} [\text{COS (THW)}/\text{COS (SALT)}]$$

Where: SAZM = Solar Azimuth (Angle between the Solar Vector. Projected onto the Horizontal Surface and the South-Pointing Vector on the Horizontal Surface) - Radians

Step 22 Obtain Cloud Cover Conditions

CT = Cloud Type

0.0 = Cirrus or Cirrostratus Clouds

1.0 = Stratus Clouds

2.0 = Other Cloud Types

TC = Total cloud Cover

1.0 = 1/10 of sky covered

2.0 = 2/10 of sky covered

.

.

.

9.0 = 9/10 of sky covered

10.0 = 10/10 of sky covered

ICT = 1 + IFIX (CT)

Where: ICT = Cloud Type indicator

1 = Cirrus or Cirrostratus Clouds

2 = Stratus Clouds

3 = Other Cloud Types

Step 23 Calculate Cloud Cover ModifierIF: TC = 0.0,THEN: CCM = 1.0 and go to Step 24IF: SALT \leq $\pi/4.0$;THEN: ISALT = 1IF: SALT $>$ $\pi/4.0$;THEN: ISALT = 2

Where: ISALT = Solar Altitude Indicator

$$\begin{aligned} \text{CCM} = & P_0 (\text{ICT}, \text{ISALT}) + P_1 (\text{ICT}, \text{ISALT}) * \text{TC} + \dots \\ & + P_2 (\text{ICT}, \text{ISALT}) * (\text{TC}^{**}2.0) + \dots \\ & + P_3 (\text{ICT}, \text{ISALT}) * (\text{TC}^{**}3.0) \end{aligned}$$

Step 23 (contd)

Where: CCM = Cloud Cover Modifier

P0, P1, P2, P3 = Polynomial Coefficients obtained from
input data tables "Cloud Cover Modifier
Polynomial Coefficients"

Step 24 Obtain Clearness Number

CN = Clearness Number

= 0.7-0.9 for an industrial atmosphere

= 0.85-1.0 for non-industrial atmospheres

Step 25 Calculate Intensity of Direct Normal Solar Radiation

$QDN = APPSC * CN * CCM * EXP(-ATMEXC/COS(THETZS))$

Where: QDN = Direct Normal Solar Radiation Intensity - Watts/Meter²

Step 26 Obtain Solar Array Pointing Angles

PHIAID = Surface Tilt Angle from Horizontal - Degrees
(Angle between local Zenith and Solar Array Normal)

PHIAAD = Surface Azimuth Angle from South - Degrees
(Angle between South pointing vector and projection
of array normal on horizontal surface)

= + if West of South

= - if East of South

Step 27 Convert Solar Array Pointing Angles

$PHIAI = PHIAID * \pi/180.0$

$PHIAA = PHIAAD * \pi/180.0$

Where: PHIAI = Surface Tilt Angle - Radians

PHIAA = Surface Azimuth Angle - Radians

- Step 28 Calculate Direction Cosines of Array Normal
(Reference Axis: Vertical, Horizontal to West, Horizontal to South)
- $$ETAA = \cos(\text{PHIAI})$$
- $$ETAB = \sin(\text{PHIAA}) * \sin(\text{PHIAI})$$
- $$ETAC = \cos(\text{PHIAA}) * \sin(\text{PHIAI})$$
- Where: ETAA, ETAB, ETAC = Array Normal Direction Cosines
- Step 29 Calculate Solar Array Tilt Angle
- $$\begin{aligned} \cos(\text{TILT}) = & ETAA * \cos(\text{THETZS}) + \dots \\ & + ETAB * \cos(\text{THW}) + \dots \\ & + ETAC * \cos(\text{THS}) \end{aligned}$$
- Where: TILT = Solar Array Tilt Angle - Radians
(Angle between Solar Vector and Solar Array Normal)
- Step 30 Calculate Intensity of Direct Solar Radiation Incident on the Solar Array
- IF: $\cos(\text{TILT}) > 0.0$
THEN: $QD = QDN * \cos(\text{TILT})$
- IF: $\cos(\text{TILT}) \leq 0.0$
THEN: $QD = 0.0$
- Where: QD = Direct Solar Radiation Incident on Solar Array - Watts/Meter²
- Step 31 Calculate Sky Brightness
- $$BS = SDF * QDN / (\text{CN} ** 2.0)$$
- Where: BS = Sky Brightness - Watts/Meter²
- Step 32 Obtain Horizontal Surface (Ground/Ocean) Reflectivity
- REFLH = Horizontal Surface Reflectivity for Solar Radiation

Step 33

Calculate Horizontal Surface Brightness

$$BG = REFLH * (BS + QDN * COS (THETZS))$$

Where: BG = Horizontal Surface Brightness - Watts/Meter²

Step 34

Calculate Intensity of Horizontal Surface Diffuse Radiation Incident on Solar Array

$$QDG = BG * ((1 - ETAA)/2.0)$$

Where: QDG = Horizontal Surface Diffuse Radiation Incident on Solar Array - Watts/Meter²

Step 35

Calculate Intensity of Sky Diffuse Radiation Incident on a Horizontal Solar Array

$$QDSH = QDN * SDF$$

Where: QDSH = Sky Diffuse Radiation Incident on a Horizontal Solar Array - Watts/Meter²

Step 36

Calculate Intensity of Sky Diffuse Radiation Incident on a Vertical Solar Array

$$YV = 0.45$$

IF: COS (TILT) > (-0.2);

THEN: $YV = 0.55 + 0.437 * COS (TILT) + 0.313 * ((COS (TILT))^{2.0})$

$$QDSV = QDN * (SDF * YV + (REFLH * (SDF + COS (THETZS))))/2.0$$

Where: QDSV = Sky Diffuse Radiation Incident on a Vertical Solar Array - Watts/Meter²

Step 37

Calculate Intensity of Sky Diffuse Radiation Incident on Solar Array

$$QDS = QDSV + (QDSH - QDSV) * COS (SALT)$$

Where: QDS = Sky Diffuse Radiation Incident on Solar Array - Watts/Meter²

Step 38 Calculate Intensity of Total Solar Insolation Incident on Solar Array

$$QDT = QD + QDG + QDS$$

Where: QDT = Total Solar Radiation Incident on Solar Array - Watts/Meter²

Step 39 Obtain Elapsed Time From Start of Mission

DATEM = Elapsed time from start of mission - days

Step 40 Obtain Current Degradation Factors for Solar Array

CDEGA = Solar Array Current Degradation Factor Due to Fabrication Losses - Percent (from zero)

CDEGB = Solar Array Current Degradation Factor Due to Terrestrial Performance Extrapolation Uncertainty - Percent (from zero)

Step 41 Calculate Current Degradation Factor Due to Environmental Effects

$$CDEGC = SADEGC (DATEM)$$

Where: CDEGC = Solar Array Current Degradation Factor Due to Environmental Effects - Percent (from zero)

SADEGC = Table of Solar Array Input Current Degradation Due to the Environment (in Percent from Zero) as a function of DATEM

Step 42 Calculate Solar Array Current Degradation Factor

$$CDEG = \frac{1.0 * 10^6 - (100.0 - CDEGA) * (100.0 - CDEGB) * (100.0 - CDEGC)}{1.0 * 10^6}$$

Where: CDEG = Solar Array Current Degradation Factor - Dimensionless

Step 43 Obtain Voltage Degradation Factor for Solar Array

VDEGA = Solar Array open circuit voltage degradation due to temperature uncertainty - Percent (from zero)

Step 44 Calculate Voltage Degradation Factor Due to Environmental Effects

VDEGB = SADEGV (DATEM)

Where: VDEGB = Solar Array Open Circuit Voltage Degradation Factor due to Environmental Effects - Percent (from zero)

SADEGV = Table of Solar Array Open Circuit Voltage Degradation due to the Environment (in percent from zero) as a function of DATEM

Step 45 Calculate Solar Array Voltage Degradation Factor

$$VDEG = \frac{1.0 * 10^4 - (100.0 - VDEGA) * (100.0 - VDEGB)}{1.0 * 10^4}$$

Where: VDEG = Solar Array Voltage Degradation Factor - Dimensionless

Step 46 Obtain Solar Cell Spectral Correction Factor

SPECOR = Solar Cell Spectral Correction Factor - Dimensionless (Corrects for differences between Spectrum of Solar Radiation Incident on Solar Cell and Spectral Response of Solar Cell)

Step 47 Calculate Effective Solar Insolation

$$X = SPECOR * QDT/10.0$$

Where: X = Effective Solar Insolation Incident on Solar Cell - Milliwatts/Cm²

Step 48 Calculate Modified Solar Insolation

$$XX = X * (1.0 - CDEG)$$

Where: XX = Modified Solar Insolation - Mw/Cm²

Step 49 Obtain Single Solar Cell Area

$$ACELL = \text{Single Solar Cell Area} - \text{Cm}^2$$

Step 50 Calculate Short Circuit Current Temperature Coefficient for a Single Solar Cell

$$ALPHAC = ((7.428 * 10^{-7}) - (1.83 * 10^{-9}) * TSAC) * (XX) * ACELL/4.0$$

Where: $ALPHAC$ = Short Circuit Current Temperature Coefficient - Amperes/°C-cell

Step 51 Calculate Solar Cell Series Resistance

$$RCELLC = F(RSCCELL, TEMTAB) \text{ at } TSAC$$

Where: $RCELLC$ = Solar Cell Series Resistance - Ohms (at Temperature $TSAC$)

$RSCCELL$ = Internal Table of Solar Cell Series Resistance as a function of Cell Temperature

$TEMTAB$ = Internal Table of Temperature Range Associated with $RSCCELL$

Step 51A Calculate Solar Cell I-V Curve Correction Factor

$$ROCELL = F(ROE, SUNLIT) \text{ at } XX$$

Where: $ROCELL$ = Solar Cell I-V Curve Correction Factor at Solar Insolation Level: XX

ROE = Internal Table of Solar Cell I-V Curve Correction Factor as a Function of Solar Insolation

$SUNLIT$ = Internal Table of Solar Insolation Range Associated with ROE

Step 52

Calculate Open Circuit Voltage Temperature Coefficient for a Single Solar Cell

$$\text{BETAA} = F[\text{BETAB}(\text{or BETAC or BETAD})] \text{ at XX and TSAC}$$

$$\text{BBETA} = \text{BETAA}/1000.0$$

Where:

BBETA = Open Circuit Voltage Temperature Coefficient - (Volts/°C) at XX and TSAC

BETAA = Open Circuit Voltage Temperature Coefficient - (Mv/°C) at XX and TSAC

BETAB, BETAC, BETAD = Internal Tables of Solar Cell Open Circuit Voltage as a Function of Solar Insolation and Cell Temperature

SUNMW, SONMW, SENMW = Internal Tables of Solar Insolation Ranges Associated with (BETA) Tables

BTEMP, CTEMP, DTEMP = Internal Tables of Solar Cell Temperature Ranges Associated with (BETA..) Tables

Internal Tables BTEMP, SUNMW AND BETAB used when:

$$(100 \leq \text{XX} \leq 540 \text{ Mw/Cm}^2) \text{ and } (-60 \leq \text{TSAC} \leq 160^\circ\text{C})$$

Internal Tables CTEMP, SONMW, BETAC used when:

$$(5 \leq \text{XX} \leq 253 \text{ Mw/Cm}^2) \text{ and } (-40 \leq \text{TSAC} \leq 60^\circ\text{C})$$

Internal Tables DTEMP, SENMW, BETAD used when:

$$(5 \leq \text{XX} \leq 100 \text{ Mw/Cm}^2) \text{ and } (-140 \leq \text{TSAC} \leq -40^\circ\text{C})$$

Step 53

Obtain Single Cell ISC, VOC Data

IISC = Solar Cell Short Circuit Current - Amperes/Cell
(at 145 Mw/Cm² Solar Insolation and 60°C)

VVOC = Solar Cell Open Circuit Voltage - Volts/Cell
(at 145 Mw/Cm² Solar Insolation and 60°C)

Step 54 Calculate ISC, VOC Shift Due to Degradation

$$C1 = CDEG * IISC$$

$$C2 = VDEG * WVOC$$

C1 = Solar Cell Short Circuit Current Shift - Amps/Cell

C2 = Solar Cell Open Circuit Voltage Shift - Volts/Cell

Step 55 Obtain Single Circuit (of Solar Cells) Arrangement

NS = No. of Solar Cells in Series in Each Circuit

NP = No. of Solar Cells in Parallel in Each Circuit

Step 56 Calculate Cell Electrical Circuit Parameters

$$ALPHA = ALPHAC * NP$$

$$BETA = BRETAC * NS$$

$$RCELL = (0.114 + RCELLC) * NS/NP$$

$$RHO = RCELL * NS/NP$$

Where: ALPHA = Short Circuit Current Temperature Coefficient
for a Single Circuit - Amperes/°C-circuit

BETA = Open Circuit Voltage Temperature Coefficient
for a Single Circuit - Volts/°C

RCELL = Single Circuit Series Resistance - Ohms

RHO = Series Resistance Temperature Correction Factor

Step 57 Calculate Modified Electrical Circuit Short Circuit Current

$$ISC = IISC * NP * (1.0 - CDEG)$$

Where: ISC = Modified Electrical Circuit Short Circuit
Current - Amperes/Circuit

Step 58 Calculate Short Circuit Current Differences (for an Electrical Circuit)

$$\text{DISC} = \text{ISC} * ((X/145.0) - 1.0) + \text{ALPHA} * (\text{TSAC} - 60.0)$$

Where: DISC = Short Circuit Current Difference due to current degradation, solar insolation changes and temperature changes - Amperes/Circuit

Step 59 Calculate Electrical Circuit Voltage and Series Resistance Correction Factors

$$C3 = \text{BETA} * (\text{TSAC} - 60.0) + \text{DISC} * \text{RCELL}$$

$$C4 = \text{RHO} * (\text{TSAC} - 60.0)$$

Where: C3 = Electrical Circuit Voltage Correction Factor - Volts/Circuit

C4 = Electrical Circuit Series Resistance Correction Factor - Ohms

Step 60 Obtain Reference Solar Cell Current-Voltage Characteristics

II(J) = Reference Solar Cell Current Data Point - Amperes
(Internal Tables)

VV(J) = Reference Solar Cell Voltage Data Point - Volts
(Internal Tables)

$$J = 1, 30$$

Step 61 Calculate Solar Cell Electrical Circuit Current-Voltage Characteristics

$$I(J) = \text{NP} * (\text{II}(J) - C1) + \text{DISC}$$

$$V(J) = \text{NS} * (\text{VV}(J) - C2) - C3 - (C4 * I(J))$$

$$J = 1, 30$$

Where: I(J) = Electrical Circuit Current - Amperes
at the given level of V(J)

V(J) = Electrical Circuit Voltage - Volts

- Step 62 Obtain Solar Array Voltage Increment
- VSAINC = Solar Array Voltage Increment - Volts
- Step 63 Redefine Electrical Circuit Current-Voltage Array in Selected Voltage Increments as follows:
- a) Set: Counter $L=1$ and voltage $V2(L) = 0.0$
 - b) Establish: Current $I1(L)$ at $V2(L)$

$$I1(L) = F\{I(J), V(J)\} \text{ at } I(J) = 0.0$$
 - c) Increment: Counter $L = L + 1$ and voltage $V2(L + 1) = V2(L) + VSAINC$ and Establish: Current $I1(L + 1)$ at $V2(L + 1)$. Until: $I1(L + 1) \leq 0.0$
 - d) Redefine: Last $V2(L)$ at $I1(L) = 0.0$

$$V2(L) = F\{I(J), V(J)\} \text{ at } I(J) = 0.0$$
 - e) Set: Current-Voltage Matrix Dimension to last counter value MFINAL = L
- Step 64 Obtain Number of Solar Cell Electrical Circuits in Solar Array
- NESP = Number of Electrical Circuits in Solar Array (assumed in parallel)
- Step 65 Calculate Solar Array Current-Voltage Characteristics
- $$I2(L) = I1(L) * NESP \text{ at } V2(L)$$
- $$L = 1, MFINAL$$
- Where: $I1(L)$ = Electrical Circuit Current - Amperes at $V2(L)$
- $I2(L)$ = Solar Array Current - Amperes at $V2(L)$
- $V2(L)$ = Circuit or Array Voltage - Volts
- Step 66 Obtain Voltage Data for Calculation of Solar Array Maximum Power Plant
- XV = Initial Voltage for Max Power Point Calculations - Volts
- DXN = Voltage Increment for Max Power Point Calculation - Volts

Step 67 Initialize Calculation Value of Solar Array Maximum Power

MSAPWR = 0.0

Where: MSAPWR = Solar Array Maximum Power - Watts

Step 68 Calculate Solar Array Power and Current

$XI = F\{I_2(L), V_2(L)\}$ at $V_2(L) = XV$

SAPWR = XI * XV

Where: XV = Solar Array Voltage - Volts

XI = Solar Array Current - Amperes

SAPWR = Solar Array Power - Watts

Step 69 Compare Solar Array Power With Maximum Power

IF: SAPWR > MSAPWR

THEN: MSAPWR = SAPWR

THEN: XV = XV + DXV

REPEAT STEP 68 UNTIL: SAPWR \leq MSAPWR

Step 70 Recalculate Solar Array Current and Power

MSAPWR = 0.0

XV = XV - DXV

REPEAT STEP 68 ONLY

Step 71 Compare Solar Array Power With Maximum Power

IF: SAPWR \geq MSAPWR

THEN: $\left\{ \begin{array}{l} \text{MSAPWR} = \text{SAPWR} \\ \text{DXV} = \text{DXV}/10.0 \\ \text{XV} = \text{XV} + \text{DXV} \end{array} \right\}$

REPEAT STEP 68 ONLY UNTIL: SAPWR < MSAPWR

- Step 72 Calculate Solar Array Maximum Power Point Characteristics
- $$\text{MAXV} = \text{XV} - \text{DXV}$$
- $$\text{MAXI} = \text{MSAPWR}/\text{MAXV}$$
- Where: MAXV = Solar Array Voltage at Max Power Point - Volts
 MAXI = Solar Array Current at Max Power Point - Amperes
- Step 73 Obtain Solar Array Electrical Section Cable Resistance
- RSA = Series resistance of cable for an electrical section of the solar array - Ohms
- Step 74 Calculate Voltage Shift in Electrical Section Voltage Due to Cable Resistance and Blocking Diodes
- $$\text{VDIODE} = \text{AD1} \{ \text{I1(L)} \}$$
- $$\text{V2(L)} = \text{V2(L)} - (\text{I1(L)} * \text{RSA}) - \text{VDIODE}$$
- $$\text{L} = 1, \text{MFINAL}$$
- Where: VDIODE = Electrical Section Blocking Diode - Volts
 Voltage Drop at Current Level I1(L)
- AD1 = Table (Input Data) of Electrical Section Blocking Diode as a function of current
- Step 75 Obtain Shunt Limiter Type
- ISH = Shunt Limiter Type
- 0 = None
 1 = Ordinary Zener Diode
 2 = Temperature Compensated Zener Diode
 3 = Active Shunt Limiter
- Step 76 Obtain Shunt Limiter Current Voltage Characteristics
- $$\text{ZI(I)} = \text{Shunt Limiter Current at ZV(I)} - \text{Amperes}$$
- $$\text{ZV(I)} = \text{Shunt Limiter Voltage} - \text{Volts}$$
- $$\text{I} = 1, 20$$

Step 77

Obtain Power Source Group Type

IPSG = Power Source Group Type

0 = One Shunt Limiter for the Solar Array

1 = One Shunt Limiter for each Electrical Section of the
Solar ArrayStep 78Select Power Source Group Current-Voltage Calculation and
Calculate Significant Voltages $VZSB = ZV(2)$ $SAOCV = V2(MFINAL)$ IF: ISH = 0; GO TO STEP 79IF: ISH = 1; GO TO STEP 80IF: ISH = 2; GO TO STEP 98IF: ISH = 3; GO TO STEP 80Where: $VZSB$ = Shunt-Limiter Turn-On Voltage - Volts $SAOCV$ = Solar Array Open Circuit Voltage - VoltsStep 79Calculate Power Source Group Current-Voltage Characteristics
(With No Shunt-Limiter) $XZI(L) = ZI(1)$ $SY(L) = I2(L) - XZI(L)$ $SX(L) = V2(L)$ $L = 1, MFINAL$ Where: $XZI(L)$ = Shunt Limiter Current at $SX(L)$ - Amperes $SY(L)$ = Power Source Group Current at $SY(L)$ - Amperes $SX(L)$ = Power Source Group Voltage - Volts

Return to Performance Analysis Routine

Step 80 Select PSG Current-Voltage Calculation Based on PSG Type

IF: IP_{PSG} = 0; GO TO STEP 81

IF: IP_{PSG} = 1; GO TO STEP 89

Step 81 Initialize Index Counter and PSG Voltage and Current

LL = 1

SY(1) = 0.0

SX(1) = F{I₂(1), V₂(L)} at V₂(L) = SX(1)

XZI(1) = 0.0

Step 82 Compare Voltage and Current to Reference Levels

IF: SY(LL) ≤ 0.0: and

IF: SX(LL) > SAOCV

THEN: GO TO STEP 88

Step 83 Increment Index Counter and Calculate PSG Voltage and Current

LL = LL + 1

SX(LL) = SX(LL - 1) + VSAINC

SY(LL) = F{I₂(L), V₂(L)} at V₂(L) = SX(LL)

XZI(LL) = 0.0

Step 84 Compare PSG Voltage with Shunt-Limiter Turn-On Voltage

IF: SX(LL) < VZSB:

THEN: REPEAT STEPS 82 AND 83

Step 85 Calculate PSG Current at Shunt Limiter Turn-On

$$SX(LL) = VZSB$$

$$SY(LL) = F\{I2(L), V2(L)\} \text{ at } V2(L) = SX(LL)$$

$$XZI(LL) = F\{ZI(I), ZV(I)\} \text{ at } ZV(I) = SX(LL)$$

$$SY(LL) = SY(LL) - XZI(LL)$$

Step 86 Compare PSG Current With Reference

IF: $SY(LL) < 0.0$

THEN: GO TO STEP 88

Step 87 Increment Index Counter and Calculate PSG Voltage and Current

$$LL = LL + 1$$

$$SX(LL) = SX(LL - 1) + 0.01$$

$$SY(LL) = F\{I2(L), V2(L)\} \text{ at } V2(L) = SX(LL)$$

$$XZI(LL) = F\{ZI(I), ZV(I)\} \text{ at } ZV(I) = SX(LL)$$

$$SY(LL) = SY(LL) - XZI(LL)$$

REPEAT STEPS 86 AND 87

Step 88 Calculate Maximum PSG Voltage

Perform a Straight-Line Interpolation between the last two sets of PSG current-voltage values to predict the voltage at which the PSG current is equal to zero (VZCR)

$$SX(LL) = VZCR$$

$$SY(LL) = 0.0$$

$$XZI(LL) = F\{ZI(I), ZV(I)\} \text{ at } ZV(I) = SX(LL)$$

$$NFINAL = LL$$

RETURN TO PERFORMANCE ANALYSIS ROUTINE

Step 89 Initialize Index Counter and Section Voltage and Current

LL = 1

VSECT(1) = 0.0

ISECT(1) = F{I1(L), V2(L)} at V2(L) = VSECT(1)

XZIS = 0.0

Where: ISECT(LL) = Electrical Section Composite Current - Amperes
at VSECT(LL)

VSECT(LL) = Electrical Section Voltage - Volts

XZIS(LL) = Shunt Limiter Section Current - Amperes

Step 90 Compare Voltage and Current to Reference Levels

IF: ISECT(LL) \leq 0.0 and

IF: VSECT(LL) \geq SAOCV;

THEN: GO TO STEP 96

Step 91 Increment Index Counter and Calculate Section Composite Voltage and Current

LL = LL + 1

VSECT(LL) = VSECT (LL - 1) + VSAINC

ISECT(LL) = F{I1(L), V2(L)} at V2(L) = VSECT(LL)

XZIS(LL) = 0.0

Step 92 Compare Section Voltage with Shunt Limiter Turn-On Voltage

IF: VSECT(LL) < VZSB;

THEN: REPEAT STEPS 90 AND 91

Step 93 Calculate Section Current at Shunt Limiter Turn-On

$$VSECT(LL) = VZSB$$

$$ISECT(LL) = F\{I1(L), V2(L)\} \text{ at } V2(L) = VSECT(LL)$$

$$XZIS(LL) = F\{ZI(I), ZV(I)\} \text{ at } ZV(I) = VSECT(LL)$$

$$ISECT(LL) = ISECT(LL) - XZIS(LL)$$

Step 94 Compare Section Current With Reference

IF: $ISECT(LL) \leq 0.0$

THEN: GO TO STEP 96

Step 95 Increment Index Counter and Calculate Section Voltage and Current

$$LL = LL + 1$$

$$VSECT(LL) = VSECT(LL - 1) + 0.01$$

$$ISECT(LL) = F\{I1(L), V2(L)\} \text{ at } V2(L) = VSECT(LL)$$

$$XZIS(LL) = F\{ZI(I), ZV(I)\} \text{ at } ZV(I) = VSECT(LL)$$

$$ISECT(LL) = ISECT(LL) - XZIS(LL)$$

REPEAT STEPS 94 AND 95

Step 96 Calculate Maximum Section Voltage

Perform a straight-line interpolation between the last two sets of section current-voltage values to predict the voltage at which the section current is equal to zero (VZCR)

$$VSECT(LL) = VZCR$$

$$ISECT(LL) = 0.0$$

$$XZIS(LL) = F\{ZI(I), ZV(I)\} \text{ at } ZV(I) = VSECT(LL)$$

$$NFINAL = LL$$

Step 97 Calculate PSG Current Voltage Characteristics

SY(LL) = ISECT(LL) * NESP

XZI(LL) = XZIS(LL) * NESP

SX(LL) = VSECT(LL)

LL = 1, NFINAL

RETURN TO PERFORMANCE ANALYSIS ROUTINE

Step 98 Select PSG Current Voltage Type Based on PSG Type

IF: IPSP = 0; GO TO STEP 99

IF: IPSP = 1; GO TO STEP 108

Step 99 Initialize Index Counter and PSG Voltage and Current

LL = 1

SX(1) = 0.0

SY(1) = F{I2(L), V2(L)} at V2(L) = SX(1)

XZI(1) = 0.0

Step 100 Compare Voltage and Current to Reference Levels

IF: SY(LL) \leq 0.0; and

IF: SX(LL) \geq SAOCV:

THEN: GO TO STEP 107

Step 101 Increment Index Counter and Calculate PSG Voltage and Current

LL = LL + 1

SX(LL) = SX(LL - 1) + VSAINC

SY(LL) = F{I2(L), V2(L)} at V2(L) = SX(LL)

XZI(LL) = 0.0

Step 102 Compare PSG Voltage With Shunt-Limiter Turn-On Voltage

IF: $SX(LL) < VZSB;$
THEN: REPEAT STEPS 100 AND 101

Step 103 Calculate PSG Current at Shunt-Limiter Turn-On

$$SX(LL) = VZSB$$

$$SY(LL) = F\{I2(L), V2(L)\} \text{ at } V2(L) = SX(LL)$$

$$XZI(LL) = F\{ZI(I), ZV(I)\} \text{ at } ZV(I) = SX(LL)$$

$$SY(LL) = SY(LL) - XZI(LL)$$

Step 104 Compare PSG Current with Reference

IF: $SY(LL) < 0.0$
THEN: GO TO STEP 107

Step 105 Calculate Zener String Voltage Increment

$$VZINC = ZV(4) - ZV(3)$$

VZINC = Zener String Voltage Increment - Volts
 beyond Zener Breakdown Voltage

Step 106 Increment Index Counter and Calculate PSG Voltage and Current

$$LL = LL + 1$$

$$SX(LL) = SX(LL - 1) + VZINC$$

$$SY(LL) = F\{I2(L), V2(L)\} \text{ at } V2(L) = SX(LL)$$

$$XZI(LL) = F\{ZI(I), ZV(I)\} \text{ at } ZV(I) = SX(LL)$$

$$SY(LL) = SY(LL) - XZI(LL)$$

REPEAT STEPS 104, 105 AND 106

Step 107 Calculate Maximum PSG Voltage

Perform a straight-line interpolation between the last two sets of PSG Current-Voltage values to predict the voltage at which the PSG current is equal to zero (VZCR)

$$SX(LL) = VZCR$$

$$SY(LL) = 0.0$$

$$XZI(LL) = F\{ZI(I), ZV(I)\} \text{ at } ZV(I) = SX(LL)$$

$$NFINAL = LL$$

RETURN TO PERFORMANCE ANALYSIS ROUTINE

Step 108 Initialize Index Counter and Section Voltage and Current

$$LL = 1$$

$$VSECT(1) = 0.0$$

$$ISECT(1) = F\{I1(L), V2(L)\} \text{ at } V2(L) = VSECT(1)$$

$$XZIS(1) = 0.0$$

Step 109 Compare Voltage and Current to Reference Levels

IF: ISECT(LL) \leq 0.0; and

IF: VSECT(LL) $>$ SAOCV;

THEN: GO TO STEP 116

Step 110 Increment Index Counter and Calculate Section Composite Voltage and Current

$$LL = LL + 1$$

$$VSECT(LL) = VSECT(LL - 1) + VSAINC$$

$$ISECT(LL) = F\{I1(L), V2(L)\} \text{ at } V2(L) = VSECT(LL)$$

$$XZIS(LL) = 0.0$$

Step 111 Compare Section Voltage With Shunt Limiter Turn-On Voltage

IF: VSECT(LL) < VZSB;
THEN: REPEAT STEPS 109 AND 110

Step 112 Calculate Section Current at Shunt Limiter Turn-On

VSECT(LL) = VZSB

ISECT(LL) = F{I1(L), V2(L)} at V2(L) = VSECT(LL)

XZIS(LL) = F{ZI(I), ZV(I)} at ZV(I) = VSECT(LL)

ISECT(LL) = ISECT(LL) - XZIS(LL)

Step 113 Compare Section Current With Reference

IF: ISECT(LL) ≤ 0.0
THEN: GO TO STEP 116

Step 114 Calculate Zener String Voltage Increment

VZINC = ZV(4) - ZV(3)

Step 115 Increment Index Counter and Calculate Section Voltage and Current

LL = LL + 1

VSECT(LL) = VSECT(LL - 1) + VZINC

ISECT(LL) = F{I1(L), V2(L)} at V2(L) = VSECT(LL)

XZIS(LL) = F{ZI(I), ZV(I)} at ZV(I) = VSECT(LL)

ISECT(LL) = ISECT(LL) - XZIS(LL)

REPEAT STEPS 113, 114 AND 115

Step 116 Calculate Maximum Section Voltage

Perform a straight-line interpolation between the last two sets of section current-voltage values to predict the voltage at which section current is equal to zero (VZCR)

$$VSECT(LL) = VZCR$$

$$ISECT(LL) = 0.0$$

$$XZIS(LL) = F\{ZI(I), ZV(I)\} \text{ at } ZV(I) = VSECT(LL)$$

$$NFINAL = LL$$

Step 117 Calculate PSG Current Voltage Characteristics

$$SY(LL) = ISECT(LL) * NESP$$

$$XZI(LL) = XZIS(LL) * NESP$$

$$SX(LL) = VSECT(LL)$$

$$LL = 1, NFINAL$$

Return to Performance Analysis Routine

Step 118 Calculate Occultation Conditions for Solar Insolation

$$QDN = 0.0$$

$$QD = 0.0$$

$$QDG = 0.0$$

$$QDS = 0.0$$

$$QDT = 0.0$$

Where: QDN = Direct, Normal Solar Insolation at Buoy Location - Watts/M²

QD = Direct Solar Insolation Incident on Solar Array - Watts/M²

QDG = Horizontal Surface Diffuse Insolation Incident on Solar Array - Watts/M²

QDS = Sky Diffuse Insolation Incident on Solar Array - Watts/M²

QDT = Total Solar Insolation Incident on Solar Array - Watts/M²

Step 118a Calculate Solar Array Maximum Power

MSAPWR = 0.0

Step 119 Obtain Solar Array Parameters

VSAINC = Solar Array Voltage Increment - Volts

KFINAL = Maximum extent of PSG group Current-Voltage
Characteristics Matrix

Step 120 Calculate PSG Current-Voltage Characteristics

SY(1) = 0.0

XZI(1) = 0.0

SX(1) = 0.0 (INITIALIZATION)

SY(LL) = 0.0

XZI(LL) = 0.0

SX(LL) = SX(LL - 1) + VSAINC

LL = 1, KFINAL

RETURN TO PERFORMANCE ANALYSIS ROUTINE

4.1.1 Shunt Limiters

The Shunt Limiter routine allows the user to specify whether an active shunt limiter, an ordinary zener diode, a temperature-compensated zener diode, or no shunting device will be used in conjunction with the solar array. The shunt device selected will not influence the solar array performance until prevailing conditions require the limiting of the array voltage. The array voltage is then clamped at a maximum potential, altering the Power Source Group current-voltage characteristics. The combined solar array/shunt limiter performance curve is the algebraic difference between the solar array and the array limiter characteristics.

PROGRAM ALGORITHMS

<u>Step 1</u>	Obtain Shunt Limiter Type
	ISH = Shunt Limiter Type
	0 = No Shunt Limiter
	1 = Ordinary Zener Diode
	2 = Temperature Compensated Zener Diode
	3 = Active Shunt Limiter
<u>Step 2</u>	Select Shunt Limiter Current-Voltage Characteristics
	<u>If:</u> ISH = 0; GO TO STEP 3
	<u>If:</u> ISH = 1; GO TO STEP 4
	<u>If:</u> ISH = 2; GO TO STEP 5
	<u>If:</u> ISH = 3; GO TO STEP 6

Step 3 Calculate No-Shunt Limiter Current Voltage Characteristics

FOR I = 1, 20

ZI(I) = 0.0

ZV(I) = 0.0

Where: ZI(I) = Shunt Limiter Current at ZV(I) - Amperes

ZV(I) = Shunt Limiter Voltage - Volts

RETURN TO POWER SOURCES GROUP ROUTINE

Step 4 Obtain Ordinary Zener Diode Current-Voltage Characteristics

ZI(I); ZV(I)

For I = 1, 20

RETURN TO POWER SOURCES GROUP ROUTINE

Step 5 Obtain Temperature Compensated Zener Diode Current-Voltage Characteristics

For I = 1, 20:

ZI(I); ZV(I)

RETURN TO POWER SOURCES GROUP ROUTINE

Step 6 Obtain Active Shunt Limiter Current-Voltage Characteristics

For I = 1, 20:

ZI(I); ZV(I)

RETURN TO POWER SOURCES GROUP ROUTINE

ORDINARY ZENER DIODE

For the Initial Load Line Analysis Calculation
go to Step 1

For Subsequent Load Line Analysis Calculations go to Step 3

Step 1 Obtain Zener Diode Operational Requirements

VZBR = Breakdown Voltage of a Single Zener Diode - Volts
(at TZBR)

TZBR = Temperature of Zener Diode - °C
(at Breakdown Voltage)

Step 2 Calculate Zener Diode Breakdown Voltage at Reference Temperature

Iterate the following equations until the change in Zener breakdown voltage at reference temperature is less than 0.1 volts. The number of iterations shall not exceed 15.

$$VZB30 = VZBR * \left[1.0 - \frac{TC * (TZBR - 30.0)}{100} \right]$$

$$TC = ZTCOEF \{VZB30\}$$

Where: VZB30 = Zener diode breakdown voltage at 30°C - Volts

TC = Zener diode temperature coefficient (%/°C) as a function of VZB30

ZTCOEF = Input table of TC as a function of VZB30

Step 3 Obtain Solar Array Temperature

TSAC = Solar Array Temperature - °Centigrade

Step 4 Calculate Zener Diode Operating Temperature

$$TJZ1 = TSAC$$

Where: TJZ1 = Zener Diode Operating Temperature - °C

Step 5 Calculate Zener Diode Breakdown Voltage

$$VZB = VZB30 * \left[1.0 + \frac{TC * (TJZ1 - 30.0)}{100.0} \right]$$

$$TC = ZTCOEF \{VZB30\}$$

Where: VZB = Single Zener Diode Breakdown Voltage - Volts
at TJZ1

Step 6 Obtain Number of Zener Diodes in a String

NZS = Number of Zener Diodes in Series

Step 7 Calculate Zener String Breakdown Voltage

$$VZSB = VZB * NZS$$

Where: VZSB = Zener String Breakdown Voltage - Volts

Step 8 Calculate Zener Diode Dynamic Impedance

$$ZZ = ZDIMP \{TJZ1, VZB30\}$$

Where: ZDIMP = Input Table of ZZ as a function of TJZ1 and VZB30

Step 9 Calculate Zener Diode Current-Voltage Characteristics

ZI(I) = Zener Diode Current - Amperes
at ZV(I)

ZV(I) = Zener Diode Voltage - Volts

$$I = 1, 20$$

Step 9 (contd)

as follows:

a) For I = 1

$$ZI(I) = 0.0$$

$$ZV(I) = 0.0$$

b) For I = 2

$$ZI(2) = 0.0$$

$$ZV(2) = VZSB$$

c) For I = 3

$$ZI(3) = 100.0$$

$$ZV(3) = VZSB + ZI(3) * ZZ * NZS$$

d) For I = 4, 20

$$ZI(I) = 0.0$$

$$ZV(I) = 0.0$$

Step 10 RETURN TO GENERAL SHUNT LIMITER ROUTINE

TEMPERATURE COMPENSATED ZENER DIODE

For the Initial Load Line Analyses Begin at Step 1

For Subsequent Load Line Analyses Begin at Step 5

Step 1 Obtain Zener Diode Operational Requirements

NZS = Number of Zener diodes in series in a string

HDZMX = Maximum Heat Dissipation of a single zener diode - Watts

HDER = Heat Dissipation Derating Factor for a single zener diode

Step 2 Calculate Reference Zener Power

$PZRF25 = HDER * HDZMX$

Where: PZRF25 = Zener diode power at 25°C - Watts

Step 3 Calculate Reference Zener Current

$IZRF25 = CURZ \{HDZMX\}$

Where: IZRF25 = Zener Diode Current at 25°C - Watts

CURZ = Input Table of IZRF25 as a function of HDZMX

Step 4 Calculate Reference Zener Voltage

$VZRF25 = PZRF25/IZRF25$

Where: VZRF25 = Zener Diode Voltage at 25°C - Volts

Step 5 Obtain Solar Array Temperature

TSAC = Solar Array Temperature - °C

Step 6 Calculate Zener Diode Operating Temperature

$$TCZ = TSAC$$

Where: TCZ = Zener Diode Operating Temperature - °C

Step 7 Calculate Zener Diode Breakdown Voltage Ratio as follows:

a). Given the formulation:

$$RATI = TCZIV(RATV, TCZ)$$

Where: RATI = Zener Diode Current Ratio at RATV and TCV

RATV = Zener Diode Voltage Ratio

TCZIV = Input table of Zener diode current-voltage characteristics (RATI, RATV) as a function of TCV

b) Then:

$$RATVB = RATV: \text{ when; } RATI = 0.0$$

Where: RATVB = Zener Diode Breakdown Voltage Ratio

Step 8 Calculate Voltage Ratio Increment Size

$$RTVINC = 1.05 - \frac{RATVB}{18.0}$$

Step 9 Calculate Zener Diode Current Ratio-Voltage Ratio Characteristics

RIZ(J) = Zener Diode Current Ratio at RVZ(J)

RVZ(J) = Zener Diode Voltage Ratio

$$J = 1, 20$$

as follows:

a) For J = 1

$$RIZ(1) = 0.0$$

$$RVZ(1) = 0.0$$

Step 9 (contd)

b) For J = 2

$$RIZ(2) = 0.0$$

$$RVZ(2) = RATVB$$

c) For J = 3, 20: Repeat Step 80; 18 times

$$RVZ(J) = RVZ(J - 1) + RTVINC$$

$$RATV = RVZ(J)$$

$$RATI = TCZIV\{RATV, TCZ\}$$

$$RIZ(J) = RATI$$

$$J = J + 1$$

Step 10 Calculate Zener Diode String Current Voltage Characteristics

ZI(J) = Zener Diode Current at ZV(J) - Amperes

ZV(J) = Zener Diode String Voltage - Volts

$$J = 1, 20$$

as follows:

$$ZI(J) = IZRF25 * RIZ(J)$$

$$ZV(J) = NZS * VZRF25 * RVZ(J)$$

Step 11 RETURN TO GENERAL SHUNT LIMITER ROUTINE

ACTIVE SHUNT LIMITER

Step 1 Obtain Shunt Limiter Operational Requirements

TSAC = Solar Array Temperature - °C

VSHTOR = Required Shunt Limiter Turn-On Voltage - Volts
at TSHREF

TSHREF = Shunt-Limiter Reference Temperature - °C

CSH = Shunt-Limiter Turn-On Voltage Coefficient - %/°C

Step 2 Calculate Shunt Limiter Operating Temperature

TSH = TSAC

Where: TSH = Shunt Limiter Operating Temperature

Step 3 Calculate Shunt Limiter Turn-On Voltage

$$VSHTO = VSHTOR \left[1.0 + \frac{CSH * (TSH - TSHREF)}{100.0} \right]$$

Where: VSHTO = Shunt Limiter Turn-On Voltage - Volts
(at TSH)

Step 4 Calculate Shunt Limiter Dynamic Impedance

ZSH = ZSHTAB(TSH)

Where: ZSH = Shunt Limiter Dynamic Impedance - Ohms

ZSHTAB = Input Table of ZSH as a function of TSH

Step 5 Calculate Shunt Limiter Current Voltage Characteristics $ZI(I) = \text{Shunt Limiter Current} - \text{Amperes}$ $ZV(I) = \text{Shunt Limiter Voltage} - \text{Volts}$ $I = 1, 3$

as follows:

a) For $I = 1$ $ZI(1) = 0.0$ $ZV(1) = 0.0$ b) For $I = 2$ $ZI(2) = 0.0$ $ZV(2) = VSHTO$ c) For $I = 3$ $ZI(3) = 100.0$ $ZV(3) = VSHTO + ZI(3) * ZSH$ d) For $I = 4, 20$ $ZI(I) = 0.0$ $ZV(I) = 0.0$ **Step 6** RETURN TO GENERAL SHUNT LIMITER ROUTINE

4.2 Energy Storage Group

The Energy Storage Group is made up of the buoy batteries, the battery cables, the battery chargers and the battery discharge diodes. The characteristics of these elements are consolidated as a function of the battery states-of-charge, temperature, number of series cells, cable resistance, and battery charge rate and are then expressed as a single set of current-voltage characteristics at the unregulated bus operating point.

The Energy Storage Group algorithms access a comprehensive set of battery charge and discharge data that are ordered in specific battery operating states and temperatures. The battery data are in the form of current-voltage curves at specified temperatures and depths of discharge. A total of 21 curves are available for each of six temperatures, 126 curves in all.

PROGRAM ALGORITHMS

<p><u>Step 1</u></p>	<p>Obtain Battery Charger Type</p> <p>ICHRT = Battery Charger Type</p> <p>0 = No Charger</p> <p>1 = Constant Voltage Charger with Current Limit</p> <p><u>IF:</u> This is Initial Load Line Analysis: <u>THEN:</u> GO TO STEP 2</p> <p><u>IF:</u> This is Subsequent Load Line Analysis: <u>THEN:</u> GO TO STEP 3</p>
----------------------	--------------------------------------------------------------------------------------------------------------------------------------------------------------------------------------------------------------------------------------------------------------------------------------------------------------------------------

Step 2

Obtain Battery Characteristics

DTTESG = Energy Storage Group Temperature Rise - °F

NBATT = Number of Batteries in Parallel

CB = Capacity of each Battery - ampere-hours

XN = Number of Cells in series in each Battery

RL = Resistance of Cable Connected to each Battery - Ohms

XICHMX = Maximum Allowable Battery Charge Current - Amperes

Step 3

Obtain Ambient Temperature

TTAMB = Ambient Temperature at Selected Location - °F

Step 4

Calculate Energy Storage Group Temperature

TTESG = TTAMB + DTTESG

Where: TTESG = Energy Storage Group Temperature - °F

Step 5

Obtain Battery State-of-Charge

QB = State of Charge of each Battery

Step 6

Calculate Battery Current-Voltage Characteristics

BRR(J,K,L) = BCQT(VCC(J,K,L), QBB(K), TBR(L))

VC(J) = VCC(J,K,L) at QBB = QB and TBR = TTESG

BR(J) = BRR(J,K,L) at VCC = VC(J), QBB = QB, and TBR = TTESG

VB(J) = VC(J) * XN

Step 6 (Contd)

$$XIB(J) = BR(J) * CB$$

$$J = 1, 9 \text{ (Data Points)}$$

$$K = 1, NQBB$$

$$L = 1, NTBB$$

Where: BRR = Normalized Battery Current Rate (expressed as ratio of battery current (amperes) to battery capacity (ampere-hours)) - Hours

$$VCC = \text{Cell Voltage} - \text{VDC}$$

$$QBB = \text{Battery State-of-Charge}$$

$$TBB = \text{Battery Temperature} - ^\circ\text{F}$$

$$BCQT = \text{Input Table of BRR as a function of VCC, QBB and TBB}$$

$$NQBB = \text{Number of QBB entries in BCQT}$$

$$NTBB = \text{Number of TBB entries in BCQT}$$

$$VC(J) = \text{Cell Voltage for each Battery} - \text{VDC}$$

$$VB(J) = \text{Battery Voltage for each battery} - \text{VDC}$$

$$BR(J) = \text{Normalized Battery Current for each Battery} - \text{Hours}^{-1}$$

$$XIB(J) = \text{Battery Current for each Battery} - \text{Hours}^{-1}$$

Step 7 Calculate Effect of Parasitic Losses

$$\text{IF: } XIB(J) \geq 0.0$$

$$\text{THEN: } VBM(J) = VB(J) + RL * XIB(J)$$

$$\text{IF: } XIB(J) < 0.0$$

$$\text{THEN: } \begin{cases} VBM(J) = VB(J) - VDIODE - RL * |XIB(J)| \\ VDIODE = AD2(|XIB(J)|) \end{cases}$$

Where: VBM = Modified Battery Voltage for each Battery - VDC

VDIODE = Battery Discharge Blocking Diode Voltage Drop - VDC

AD2 = Input Table of VDIODE as a function of battery discharge current

$$J = 1, 9$$

Step 7 (Contd)

IF: ICHRT = 1
THEN: GO TO STEP 17

Step 8 Rearrange Modified Battery Voltage Data into One Array in Ascending Order

TRESLT(J,1) = F{VBM(J)} (in ascending order)

J = 1, 9

Where: TRESLT(J,1) = Energy Storage Group Voltage - VDC

Step 9 Initialize Counter and Special Voltage Array

LL = 1

LY = 1

TRESVT(LY) = TRESLT(LL,1)

Where: TRESVT = Special Voltage Array for ES Group - VDC

LY = Remaining Number of Modified Voltage Points

Step 10 Index Counter and Compare Voltage Differences

LL = LL + 1

IF: |(TRESLT(LL,1) - TRESLT((LL-1),1)| < 0.01
THEN: REPEAT STEP 10

Step 11 Index Counter and Calculate Values in Special Voltage Array

LY = LY + 1

TRESVT(LY) = TRESLT(LL,1)

IF: LL > 9
THEN: GO TO STEP 12

REPEAT STEPS 10 AND 11

Step 12 Calculate Revisions to Energy Storage Group Voltage

TRESLT(LL,1) = 0.0

LL = 1,9

TRESLT(LY,1) = TRESVT(LY)

LY = 1,9

Step 13 Calculate Individual Battery Voltage

$$TRESV(LY) = TRESLT(LY,1)$$

$$LY = 1,9$$

Where: TRESV = Individual Battery Voltage - VDC

Step 14 Calculate Average Battery Cell Voltages

$$VCM(J) = VCM(J)/XN$$

$$J = 1,9$$

Where: VCM = Modified Average Cell Voltage - VDC

Step 15 Calculate Individual Battery Current

$$TRESI(J) = F\{XIB(J),VCM(J)\} \text{ at values of } VCM(J) = TRESV(J)/XN$$

$$J = 1,9$$

Where: TRESI = Individual Battery Current - Amperes

Step 16 Calculate Total Battery Current

$$TRESLT(LY,2) = TRESI(LY) * NBATT$$

$$LY = 1,9$$

Where: TRESLT(LY,2) = Energy Storage Group Current - Amperes
at TRESLT(LY,1)

$$TRESLT(LY,1) = \text{Energy Storage Group Voltage} - \text{VDC}$$

RETURN TO PERFORMANCE ANALYSIS ROUTINE

Step 17 Enlarge Modified Current-Voltage Characteristic Array

$$XIBBM(JJ) = XIB(J)$$

$$VBMM(JJ) = VBM(J)$$

$$JJ = J$$

$$J = 1,9$$

But, allow for an extra location so that (JJ)_{maximum} = 10

Step 18 Insert Battery Voltage Corresponding to Maximum Allowable Battery Current (XICMIX) into Modified Current-Voltage Characteristic Array such that the array contains I-V data for that point.

Thus,

VBBM(JJ) = Modified Battery Voltage for each Battery - VDC

XIBBM(JJ) = Battery Current for each Battery - Ampere
Corresponding to VBBM(JJ)

JJ = 1,10

Step 19 Obtain Battery Charger Reference Voltages

VCHIO = VCHIOT{TTEG}

VCHISA = VCHIST{TTEG}

Where: VCHIO = Battery Charger Input Voltage at Turn-On - VDC
(Minimum Voltage Drop at Zero Current Level)

VCHISA = Battery Charger Input Voltage - VDC
at which operation changes from "saturated" to
"active" conditions

VCHIOT = Input table of VCHIO as a function of TTEG

VCHIST = Input table of VCHISA as a function of TTEG

Step 20 Obtain Battery Charger Impedance

ZCHRS = ZCHRST{TTEG}

ZCHRA = ZCHRSA{TTEG}

Where: ZCHRS = Output Impedance of Battery Charger in "saturated"
condition - Ohms

ZCHRA = Output Impedance of Battery Charger in "active"
condition - Ohms

ZCHRST = Input Table of ZCHRS as a function of TTEG

ZCHRAT = Input Table of ZCHRA as a function of TTEG

Step 21 Obtain Battery Charger Impedance

ZCHRS = ZCHRST{TTEG}

ZCHRA = ZCHRSA{TTEG}

Step 21 (Cont)

Where: ZCHRS = Output Impedance of Battery Charger in "saturated" condition - Ohms

ZCHRA = Output Impedance of Battery Charger in "active" condition - Ohms

ZCHRST = Input Table of ZCHRS as a function of TTESG

ZCHRAT = Input Table of ZCHRA as a function of TTESG

Step 23 Initialize Counter

JJ = 1

Step 24 Calculate Energy Storage Unit Discharge I-V Characteristics and Then Increment Counter

IF: XIBBM(JJ) \geq 0.0

THEN: GO TO STEP 25

VESI(JJ) = VBBM(JJ)

XIEST(JJ) = XIBBM(JJ)

JJ = JJ + 1

Where: VESI(JJ) = Energy Storage Unit Input Voltage - VDC

XIESI(JJ) = Energy Storage Unit Input Current
(Corresponding to VESI(JJ)) - Amperes

Repeat Step 24

Step 25 Compare Power Sources Group Maximum Voltage with Reference Voltages

IF: (VPSGMX) > (VCHIO + VBBM(JJ))

THEN: GO TO STEP 28

Step 26 Calculate Energy Storage Unit Charge I-V Characteristics and Increment Counter

IF: JJ > 10

THEN: GO TO STEP 27

VESI(JJ) = VBBM(JJ)

XIESI(JJ) = 0.0

REPEAT STEP 26

Step 28 Calculate Estimate of Charger Input Voltage

$$VCHOOS = VBBM(JJ) + XIBBM(JJ) * ZCHRS$$

$$VESS = VCHOOS + VCHIO$$

IF: $VESS \geq VCHISA$

THEN: GO TO STEP 30

Where: VCHOOS = Battery Charger Output Voltage (in "saturated" condition) at zero current - VDC

VESS = Estimate of Battery Charger Input Voltage in "saturated" condition - VDC

Step 29 Calculate Energy Storage Unit Charge I-V Characteristics and Increment Counter

IF: $JJ > 10$

THEN: GO TO STEP 27

$$XIESI(JJ) = XIBBM(JJ)$$

$$VESI(JJ) = VESS$$

$$JJ = JJ + 1$$

RETURN TO STEP 28

Step 30 Calculate Estimate of Charger Input Voltage

$$VCHOOA = VBBM(JJ) + XIBBM(JJ) * ZCHRA$$

$$VESA = VCHIT(VCHOOA, TTESG)$$

Where: VCHOOA = Battery Charger Output Voltage (in "active" condition) at zero current - VDC

VESA = Estimate of Battery Charger Input Voltage in "active" condition - VDC

VCHIT = Input Table of VESA as a function of VCHOOA and TTESG

Step 31 Calculate Energy Storage Unit Charge I-V Characteristics and Increment Counter

IF: $JJ > 10$

THEN: GO TO STEP 27

Step 31 (Contd)

XIESI(JJ) = XIBBM(JJ)

VESI(JJ) = VESA

JJ = JJ + 1

RETURN TO STEP 30

Step 32 Compare Battery Charger Input Current with Reference Current Limit

IF: XIESI(JJ) > XICIMX

THEN: XIESI(JJ) = XICIMX

JJ = 1,10

Step 33 Rearrange Energy Storage Unit Voltage Data into One Array in Ascending Order

TRESLT(JJ,1) = F{VESI(JJ)} (in ascending order)

JJ = 1, 10

Step 34 Initialize Counter and Special Voltage Array

LL = 1

LY = 1

TRESVT(LY) = TRESLT(LL,1)

Step 35 Index Counter and Compare Voltage Differences

LL = LL + 1

IF: |(TRESLT(LL,1) - TRESLT((LL - 1),1))| < 0.01

THEN: REPEAT STEP 35

Step 36 Index Counter and Calculate Values in Special Voltage Array

LY = LY + 1

TRESVT(LY) = TRESLT(LL,1)

IF: LL > 10

THEN: GO TO STEP 37

REPEAT STEPS 35 AND 36

Step 37 Calculate Revisions to Energy Storage Group Voltage

$$\text{TRESLT}(\text{LL},1) = 0.0$$

$$\text{LL} = 1,10$$

$$\text{TRESLT}(\text{LY},1) = \text{TRESVT}(\text{LY})$$

$$\text{LY} = 1,10$$

Step 38 Calculate Individual Energy Storage Unit Voltage

$$\text{TRESV}(\text{LY}) = \text{TRESLT}(\text{LY},1)$$

$$\text{LY} = 1,10$$

Step 39 Calculate Energy Storage Unit Equivalent Single Cell Voltage

$$\text{VESIC}(\text{JJ}) = \text{VESI}(\text{JJ})/\text{XN}$$

$$\text{JJ} = 1,10$$

Where: VESIC = Equivalent Single Cell Voltage of an Energy Storage Unit - VDC

Step 40 Calculate Energy Storage Unit Current

$$\text{TRESI}(\text{LY}) = \text{F}\{\text{XIESI}(\text{JJ}),\text{VESIC}(\text{JJ})\}$$

$$\text{At values of: VESIC}(\text{JJ}) = \text{TRESV}(\text{LY})/\text{XN}$$

$$\text{JJ} = 1,10$$

$$\text{LY} = 1,10$$

Step 41 Calculate Total Energy Storage Group Current

$$\text{TRESLT}(\text{LY},2) = \text{TRESI}(\text{LY}) * \text{NBATT}$$

$$\text{LY} = 1,10$$

RETURN TO PERFORMANCE ANALYSIS ROUTINE

4.3 Power Conditioning and Distribution Group

The Power Conditioning and Distribution Group is made up of two sub-assemblies: the Lamp Flasher and the Housekeeping Regulator. The characteristics of the subassemblies are computed as a function of the lamp flasher pattern and the lamp flasher condition (on, off, or flashing). These characteristics are then shifted for the combined effects of wiring and connector series resistance to give a single set of current-voltage curves at the unregulated bus.

PROGRAM ALGORITHMS

For the Initial Load Line Analysis, GO TO STEP 1

For Subsequent Load Line Analysis, GO TO STEP 13

Step 1 Obtain Flasher Pattern Type

IF: IFTYPE = 0, GO TO STEP 3

Where: IFTYPE = Type of flasher pattern

IFTYPE = 0: Non-Standard Pattern

IFTYPE > 0: Standard Pattern

Step 2 Calculate Standard Flasher Pattern

$TL1(J) = TLO(IFTYPE, J)$

$(1 \leq IFTYPE \leq 15)$ (15 standard pattern types)

$(1 \leq J \leq 16)$ { Up to 16 steps per pattern }
 { Alternate On/Off }

Where: $TLO(IFTYPE, J)$ = Input table containing the patterns exhibited by the Standard Lamp Flashers

$TL1$ = Selected Lamp Flasher Pattern

GO TO STEP 4

Step 3 Calculate Non-Standard Flasher Pattern

$TL1(J) = TLL1(J)$ $(1 \leq J \leq 16)$

Where: $TLL1(J)$ = Input data containing up to 16 alternate on-off steps for the Non-Standard Flasher Pattern

Step 4 Calculate Total Duration of Lamp Illumination and Lamp Shut-Off

$$TLON = \sum_{J=1,3,5\dots}^{15} TL1(J)$$

$$TLOFF = \sum_{J=2,4,6\dots}^{16} TL1(J)$$

Where: TLON = Total duration of lamp illumination
 TLOFF = Total duration of lamp shut-off

{ in a single
flasher
period

IF: TLON \leq 0 and TLOFF \leq 0 stop program and

Print: "No flasher pattern entries"

Step 5 Calculate Lamp Duty Cycle

$$DL = TLON / (TLON + TLOFF)$$

Where: DL = Lamp Duty Cycle

Step 6 Obtain Lamp Characteristics

VLR = Lamp Voltage Rating - VDC

CLR = Lamp Current Rating - Amperes

CLS = Cold-Filament Lamp Surge Coefficient

Step 7 Calculate Actual Lamp Current

$$IL = CLS * CLR$$

Where: IL = Actual Lamp Current -Amperes

Note: IF: DL = 1.0
THEN: CLS = 1.0

IF: DL < 1.0
THEN: CLS > 1.0

Step 8 Calculate Actual Lamp Resistance

$$R_L = \frac{V_{LR}}{I_L}$$

Where: R_L = Actual Lamp Resistance - Ohms

Step 9 Calculate Average Lamp Current

$$\bar{I}_L = I_L * DL$$

Where: \bar{I}_L = Average Lamp Current - Amperes

Step 10 Calculate Effective Lamp Resistance

$$\bar{R}_L = V_{LR} / \bar{I}_L$$

Where: \bar{R}_L = Effective Lamp Resistance - Ohms

Step 11 Obtain Raw Power Bus Voltage Limits and User Load Cable Resistance

V_{MINIV} = Minimum Raw Power Bus Voltage - VDC

V_{MAXIV} = Maximum Raw Power Bus Voltage - VDC

R_{LL} = User Load Cable Resistance - Ohms

Step 12 Calculate PCD Group Voltage Increment

$$V_{INCIV} = (V_{MAXIV} - V_{MINIV}) / 50.0$$

Where: V_{INCIV} = PCD Group Voltage Increment - VDC

Step 13 Obtain PCD Equipment Temperature Characteristics

T_{TAMB} = Ambient Temperature - °F

DT_{PCD} = PCD Equipment Temperature Rise - °F

Step 14 Calculate PCD Equipment Temperature

$$TTPCD = TTAMB + DTTPCD$$

Where: TTPCD = PCD Equipment Temperature - °F

Step 15 Compare Raw Power Bus Minimum Voltage With Reference

IF: $VMINIV \leq VRIO$

THEN: GO TO STEP 16

IF: $(VMINIV > VRIO)$ and $(VMINIV \leq VRISA)$

THEN: GO TO STEP 24

IF: $VMINIV > VRISA$

THEN: GO TO STEP 29

Where: $VRIO$ = Minimum (No Current) Voltage Drop - VDC
Across Lamp Regulator in "Saturated" Condition

$VRISA$ = Voltage level at which lamp regulator - VDC
changes from "Saturated" condition operation
to "Active" operation

$$VRIO = VRIOT(TTPCD)$$

$$VRISA = VRISAT(TTPCD)$$

Step 16 Initialize Counter and Lamp Regulator Voltage

$$J = 1$$

$$VRI(J) = VMINIV$$

Step 17 Calculate Lamp Regulator Current

$$IRI(J,1) = 0.0$$

$$IRI(J,2) = 0.0$$

$$IRI(J,3) = 0.0$$

Where: $VRI(J)$ = Lamp Regulator Input Voltage - VDC

$IRI(J,K)$ = Lamp Regulator Input Current - Volts

Step 17 (contd)

When: K = 1 - Lamp Off
 K = 2 - Lamp Flashing - Effective
 K = 3 - Lamp On

Step 18 Increment Counter and Lamp Regulator Voltage and Compare With Reference
$$J = J + 1$$

$$VRI(J) = VRI(J - 1) + VINCIV$$

IF: (VRI(J) > VRIO) and

IF: (VRI(J) < VMAXIV)

THEN: GO TO STEP 20

IF: VRI(J) > VMAXIV

THEN: GO TO STEP 32

Step 19 Calculate Lamp Regulator Currents
$$IRI(J,1) = 0.0$$

$$IRI(J,2) = 0.0$$

$$IRI(J,3) = 0.0$$

REPEAT STEPS 18 AND 19

Step 20 Calculate Lamp Regulator Current
$$IRI(J,1) = 0.0$$

$$IRI(J,2) = (VRI(J) - VRIO) / (\overline{RL} + ZRS)$$

$$IRI(J,3) = (VRI(J) - VRIO) / (RL + ZRS)$$

Where: ZRS = Regulator Impedance in "Saturated" Condition - Ohms

$$ZRS = ZRST(TTPCD)$$

ZRST = Input Table of ZRS as a function of TTPCD

Step 21 Increment Counter and Lamp Regulator Voltage and Compare with Reference

$$J = J + 1$$

$$VRI(J) = VRI(J - 1) + VINCIV$$

IF: (VRI(J) > VRISA) and

IF: (VRI(J) < VMAXIV)

THEN: Go to Step 22

IF: VRI(J) > VMAXIV

THEN: GO TO STEP 32

REPEAT STEPS 20 AND 21

Step 22 Calculate Lamp Regulator Currents

$$IRI(J,1) = 0.0$$

$$IRI(J,2) = V_{LB} / (\overline{RL} + ZRA)$$

$$IRI(J,3) = V_{LB} / (RL + ZRA)$$

Where: V_{LB} = Regulator Output Voltage at Zero Current - Volts

ZRA = Regulator impedance in "Active" region - Ohms

$$VLB = VLBT\{VRI, TTPCD\}$$

$$ZRA = ZRAT\{TTPCD\}$$

Where: VLBT = Input Table of VLB as a function of VRI and TTPCD

ZRAT = Input Table of ZRA as a function of TTPCD

Step 23 Increment Counter and Lamp Regulator Voltage and Compare With Reference

$$J = J + 1$$

$$VRI(J) = VRI(J - 1) + VINCIV$$

IF: VRI(J) > VMAXIV

THEN: GO TO STEP 32

REPEAT STEPS 22 AND 23

Step 24 Initialize Counter and Lamp Regulator Voltage

$$J = 1$$

$$VRI(J) = VMINIV$$

Step 25 Calculate Lamp Regulator Currents

$$IRI(J,1) = 0.0$$

$$IRI(J,2) = (VRI(J) - VRIO) / (\overline{RL} + ZRS)$$

$$IRI(J,3) = (VRI(J) - VRIO) / (RL + ZRS)$$

Step 26 Increment Counter and Lamp Regulator Voltage and Compare with Reference

$$J = J + 1$$

$$VRI(J) = VRI(J - 1) + VINCIV$$

IF: (VRI(J) > VRISA) and

IF: (VRI(J) < VMAXIV)

THEN: GO TO STEP 27

IF: VRI(J) > VMAXIV

THEN GO TO STEP 32

REPEAT STEPS 25 AND 26

Step 27 Calculate Lamp Regulator Currents

$$IRI(J,1) = 0.0$$

$$IRI(J,2) = VLB / (\overline{RL} + ZRA)$$

$$IRI(J,3) = VLB / (RL + ZRA)$$

Step 28 Increment Counter and Lamp Regulator Voltage and Compare with Reference

$$J = J + 1$$

$$VRI(J) = VRI(J - 1) + VINCIV$$

IF: $VRI(J) > VMAXIV$
THEN: GO TO STEP 32

REPEAT STEPS 27 AND 28

Step 29 Initialize Counter and Lamp Regulator Voltage

$$J = 1$$

$$VRI(J) = VMINIV$$

Step 30 Calculate Lamp Regulator Currents

$$IRI(J,1) = 0.0$$

$$IRI(J,2) = VLB / (\overline{RL} + ZRA)$$

$$IRI(J,3) = VLB / (RL + ZRA)$$

Step 31 Increment Counter and Lamp Regulator Voltage and Compare with Reference

$$J = J + 1$$

$$VRI(J) = VRI(J - 1) + VINCIV$$

IF: $VRI(J) > VMAXIV$
THEN: GO TO STEP 32

REPEAT STEPS 30 AND 31

Step 32 Calculate PCD Group Current

$$XI(J,K) = IHI(J) + IRI(J,K)$$

$$IHI(J) = IHIT\{VRI(J), TTPCD\}$$

$$J = 1, 50$$

$$K = 1, 3$$

Where: $XI(J,K)$ = PCD Group Current - Amperes

$IHI(J)$ = Housekeeping Load Regulator Input
Current - Amperes

$IHIT$ = Input Table of $IHI(J)$ as a function of $VRI(J)$
and $TTPCD$

Step 33 Calculate PCD Group Voltage

$$XX(J,K) = VRI(J) + XI(J,K) * RLL$$

$$J = 1, 50$$

$$K = 1, 3$$

Where: $XX(J,K)$ = PCD Group Voltage - VDC

5. MERGE

The MERGE program set is a group of computer programs (TDF14, DECK280, and LISTMERGE) which provide a support function to the DSPA program. The purpose of the MERGE package is to provide a means for extracting actual weather information from NOAA data tapes and using it as input to the DSPA program. The three MERGE programs and their functions are described below.

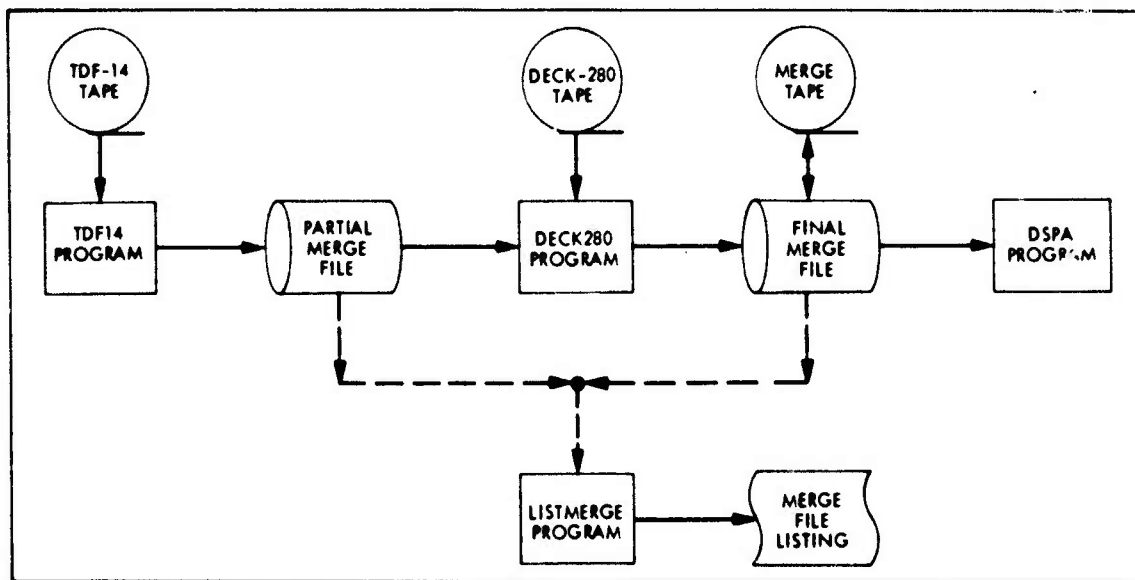

FIGURE 5-1. MERGE COMPUTER PROGRAMS OVERVIEW

5.1. Creation of a MERGE File (TDF14)

The building of the skeletal MERGE file is controlled by the TDF14 program. The user requests the creation of a MERGE file to span a particular period of years for a selected location from a NOAA TDF-14 weather tape. The TDF14 program then extracts the date, temperature, and wind velocity data from the NOAA tape, builds a one-day record consisting of 24 hourly observations of temperature and wind velocity and space for solar insolation, and sequentially writes the day's information to a MERGE file.

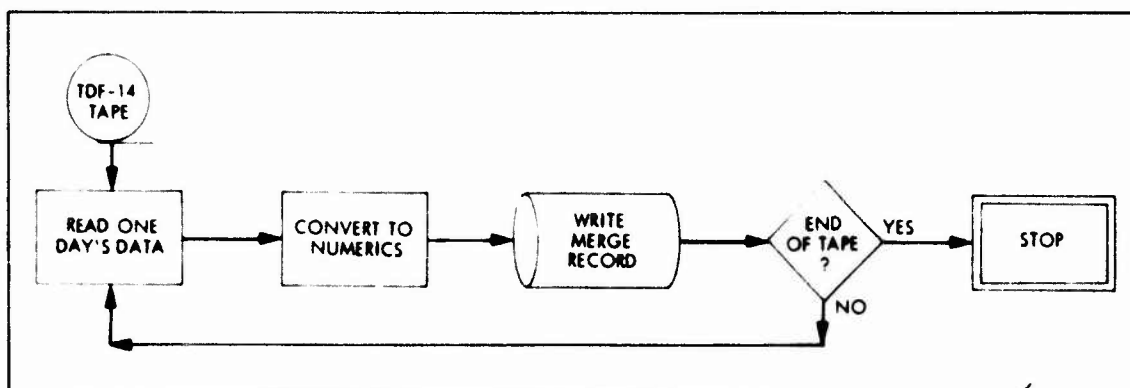

FIGURE 5-2. TDF14 COMPUTER PROGRAM

PROGRAM ALGORITHMS

- Step 1 Obtain one day's weather data from TDF-14 input tape
- Step 2 Convert TDF-14 data to numerics (DECODE)
- Step 3 Write MERGE file record
- Step 4 If: end of TDF-14 tape,
Then: Stop Program
Otherwise: Go TO STEP 1

5.2 Addition of Solar Insolation Data to MERGE File (DECK280)

The addition of solar insolation data to a MERGE file created by TDF14 is performed by the DECK280 program. The user requests that, for a particular MERGE location, NOAA DECK-280 tape data from a specified location be inserted into the file. The DECK280 program extracts the solar radiation data (in Langleys) from the NOAA tape, converts the data to watts/square meter, and adds the data to the appropriate day and hour position in the MERGE file.

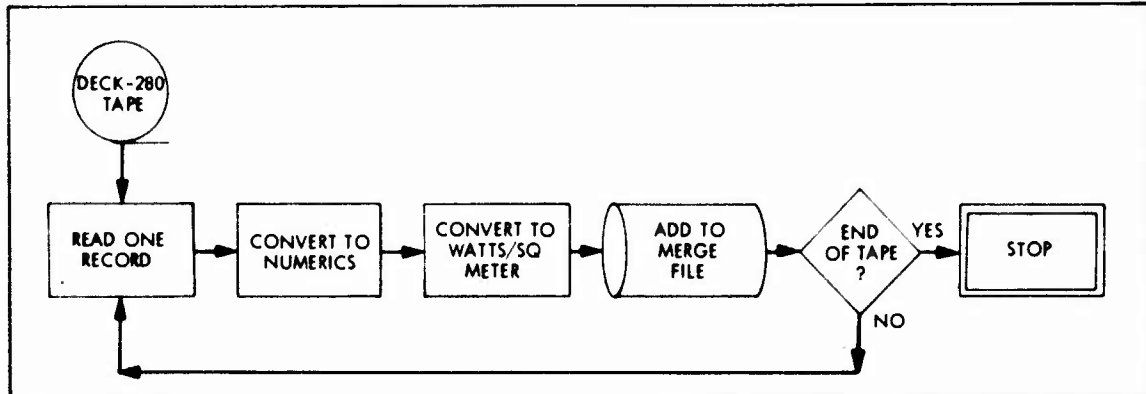

FIGURE 5-3. DECK280 COMPUTER PROGRAM

PROGRAM ALGORITHMS

<u>Step 1</u>	Obtain solar radiation data from DECK-280 input tape
<u>Step 2</u>	Convert DECK-280 data to numerics (DECODE)
<u>Step 3</u>	Convert DECK-280 data to watts/square meter $Q = S * 41.82/3.6$ where: S = Solar Insolation - Langleys Q = Solar Insolation - watts/meter ²
<u>Step 4</u>	Add solar insolation data to appropriate day and hour in MERGE file
<u>Step 5</u>	<u>If:</u> end of Deck-280 tape, <u>Then:</u> Stop Program <u>Otherwise:</u> GO TO STEP 1

5.3 Displaying MERGE File Data (LISTMERGE)

The average MERGE file consists of from 10 to 12 years of hourly temperature, wind velocity, and solar insolation data recordings. The LISTMERGE program permits the user to randomly view any number of sequential days within the file beginning at any date contained in the file.

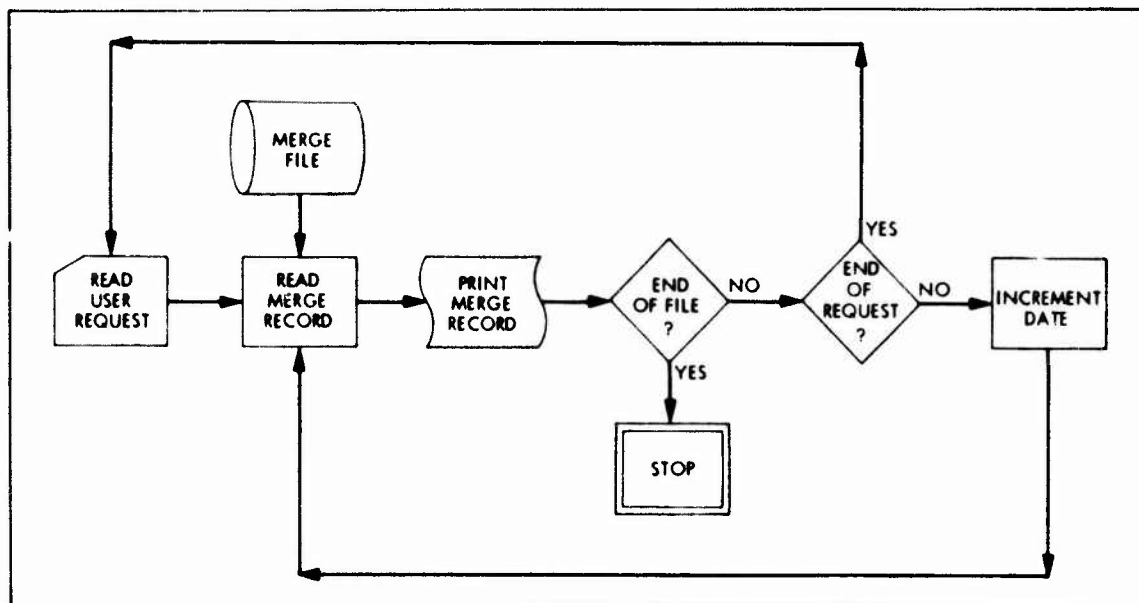

FIGURE 5-4. LISTMERGE COMPUTER PROGRAM

PROGRAM ALGORITHMS

- Step 1 obtain user request date (YYDDD) and number of days to be displayed (N)
- Step 2 Initialize day counter
I = 1
- Step 3 Obtain MERGE record for day YYDDD
- Step 4 Print MERGE record information
- Step 5 If: last day of MERGE file,
Then: Stop Program
Otherwise, if: I > N,
Then: GO TO STEP 1
Otherwise: I = I + 1
- Step 6 Increment request date
YYDDD = YYDDD + 1

Step 7 If: $DDD \geq 366$
 Then: $YY = YY + 1$
 Then: $DDD = 1$

Step 8 GO TO STEP 3

6. STAT

The STAT program set is a group of computer programs (STATS and PROFILE) which provide a support function to the DSPA program. The purpose of the STAT package is to provide a means of producing a single year of statistical data from a MERGE file, and using it as input to the DSPA program. The two STAT programs and their functions are described below.

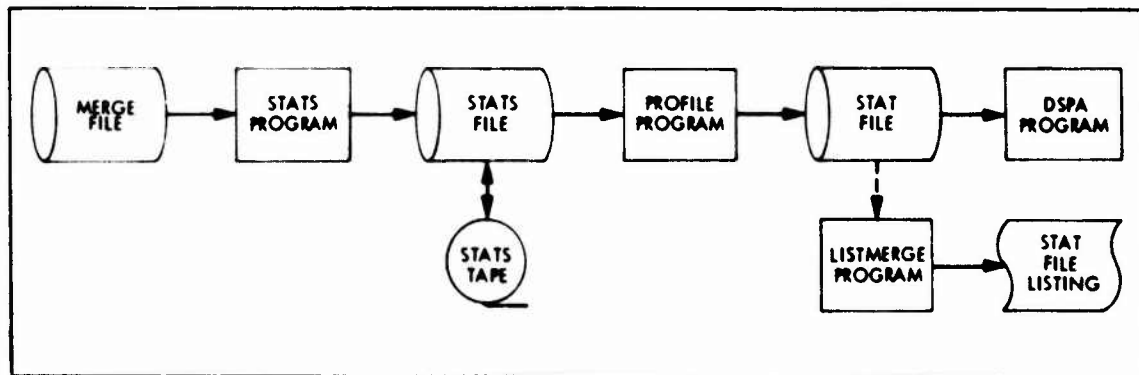

FIGURE 6-1. STAT COMPUTER PROGRAMS OVERVIEW

6.1 Statistical Analysis of MERGE File Data (STATS)

The STATS program uses the 10 to 12 years of MERGE file weather data to produce a one-year statistical file. The procedure involves the averaging of data for a given hour of a given day of each of the years contained in the MERGE file. The statistical data is then written to a STATS file which is used as input to the PROFILE program (see Section 6.2 below). Specifically, the STATS program computes and outputs (both to the STATS file and to a printer) the following statistics:

- 1a) Average temperature for each hour of one year.
- 1b) Average wind velocity for each hour of one year.
- 1c) Average solar insolation for each hour of one year.
- 2a) Average wind velocity for each day of each data year.
- 2b) Average solar insolation for each day of each data year.
- 3a) Average wind velocity for each day of one year.
- 3b) Average solar insolation for each day of one year.
- 4a) Average temperature for each month of each data year.

5040-27 (Change 1)

- 4b) Average wind velocity for each month of each data year.
- 4c) Average solar insolation for each month of each data year.
- 5a) Average temperature for each month of one year.
- 5b) Average wind velocity for each month of one year.
- 5c) Average solar insolation for each month of one year.
- 6a) Standard deviation of statistics gathered in 4a.
- 6b) Standard deviation of statistics gathered in 4b.
- 6c) Standard deviation of statistics gathered in 4c.
- 7a) Maximum temperature for each year.
- 7b) Minimum temperature for each year.
- 8a) Mean and standard deviation of statistics gathered in 7a.
- 8b) Mean and standard deviation of statistics gathered in 7b.

PROGRAM ALGORITHMS

Step 1 Initialize yearly minimum and maximum temperatures

TMIN(J) = 1000.0
TMAX(J) = -1000.0
for J=1, 12

Step 2 Initialize monthly sums for each year

MTSUM(J) = 0.0
MVSUM(J) = 0.0
MQSUM(J) = 0.0
for J=1, 12

where: MTSUM(J) = monthly temperature total for year J
MVSUM(J) = monthly wind velocity total for year J
MQSUM(J) = monthly solar insolation total for year J

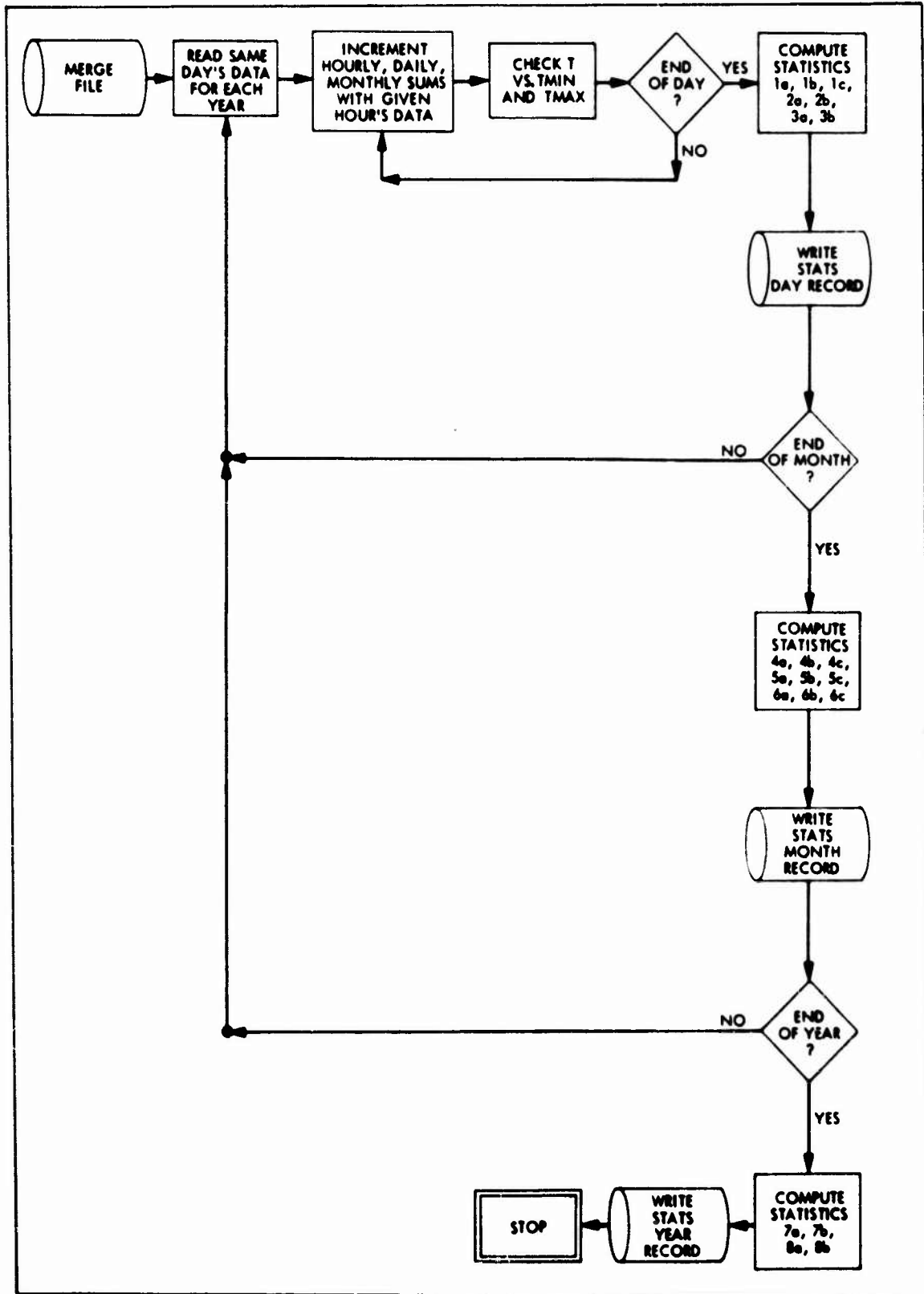

FIGURE 6-2. STATS COMPUTER PROGRAM

Step 3 Initialize daily sums for each year

DVSUM(J) = 0.0

DQSUM(J) = 0.0

for J=1, 12

where: DVSUM(J) = daily wind velocity total for year J

DQSUM(J) = daily solar insolation total for year J

Step 4 Obtain hourly temperature, wind velocity, and solar insolation data for same day of each MERGE year (NYRS \leq 12)

T(I,J) = temperature for hour I of year J

V(I,J) = wind velocity for hour I of year J

Q(I,J) = solar insolation for hour I of year J

Step 5 Initialize hour counter

I = 1

Step 6 Initialize hourly sums

TSUM = 0.0

VSUM = 0.0

QSUM = 0.0

where: TSUM = hourly temperature total over all years

VSUM = hourly wind velocity total over all years

QSUM = hourly solar insolation total over all years

Step 7 Initialize year counter

J = 1

Step 8 Add hour's data to sums

TSUM = TSUM + T(I,J)

VSUM = VSUM + V(I,J)

QSUM = QSUM + (Q(I,J)

DVSUM(J) = DVSUM(J) + V(I,J)

DQSUM(J) = DQSUM(J) + Q(I,J)

MTSUM(J) = MTSUM(J) + T(I,J)

MVSUM(J) = MVSUM(J) + V(I,J)

MQSUM(J) = MQSUM(J) + Q(I,J)

Step 9 Select minimum and maximum temperatures

$TMIN(J) = AMIN1(TMIN(J), T(I, J))$
 $TMAX(J) = AMAX1(TMAX(J), T(I, J))$

Step 10 If: J = NYRS
 Then: GO TO STEP 11
 Otherwise: J=J+1
 And: GO TO STEP 8

Step 11 Compute hourly statistics

$TOUT(I) = TSUM/NYRS$
 $VOUT(I) = VSUM/NYRS$
 $QOUT(I) = QSUM/NYRS$

where: TOUT(I) = average temperature for hour I
 VOUT(I) = average wind velocity for hour I
 QOUT(I) = average solar insolation for hour I

Step 12 If: I = 24
 Then: GO TO 13
 Otherwise: I=I+1
 And: TO TO STEP 6

Step 13 Compute daily statistics for each year

$VDAY(J) = DVSUM(J)/(24 * NYRS)$
 $QDAY(J) = DQSUM(J)/(24 * NYRS)$
 for J=1,NYRS

where: VDAY(J) = average wind velocity for given day of year J
 QDAY(J) = average solar insolation for given day of
 year J

Step 14 Write statistical day record to STATS file

Step 15 If: last day of month
 Then: GO TO STEP 16
 Otherwise: GO TO STEP 3

Step 16 Compute monthly statistics for each year

$$TOUT(J) = MTSUM(J)/(24*NYRS*NDYS)$$

$$YOUT(J) = MVSUM(J)/(24*NYRS*NDYS)$$

$$QOUT(J) = MQSUM(J)/(24*NYRS*NDYS)$$

for J=1,NYRS

where: TOUT(J) = average temperature for given month of year J

VOUT(J) = average wind velocity for given month of
year J

QOUT(J) = average solar insolation for given month of
year J

NDYS = number of days in current month

Step 17 Compute mean monthly statistics and standard deviations

$$XOUT(13) = \sum_{J=1}^{NYRS} XOUT(J)/NYRS$$

$$XOUT(14) = \text{SQRT} \left[\left(\sum_{J=1}^{NYRS} XOUT(J)**2 - NYRS * \left(\sum_{J=1}^{NYRS} XOUT(J) \right)**2 \right) / (NYRS-1) \right]$$

where: XOUT is used to represent each of the TOUT, VOUT, and
QOUT variables since the equations are of the same
form for each

Step 18 Write statistical month record to STATS file

Step 19 If: last day of year

Then: GO TO STEP 20

Otherwise: GO To STEP 2

Step 20 Compute mean TMIN and TMAX and standard deviations

$$TOUT(1) = \sum_{J=1}^{NYRS} TMIN(J)/NYRS$$

$$TOUT(2) = \text{SQRT} \left[\left(\sum_{J=1}^{NYRS} TMIN(J)**2 - NYRS * \left(\sum_{J=1}^{NYRS} TMIN(J) \right)**2 / (NYRS-1) \right) \right]$$

$$TOUT(3) = \sum_{J=1}^{NYRS} TMAX(J)/NYRS$$

$$TOUT(4) = \text{SQRT} \left[\left(\sum_{J=1}^{NYRS} TMAX(J)**2 - NYRS * \left(\sum_{J=1}^{NYRS} TMAX(J) \right)**2 / (NYRS-1) \right) \right]$$

Step 21 Write yearly statistical data to STATS file

Step 22 Stop Program

6.2 Environmental Profiling of STATS Data (PROFILE)

The PROFILE program uses the one year of statistically prepared STATS data to produce a modified statistical file for use with the DSPA program. The procedure involves the scaling of the STATS file data, on a monthly basis, by factors computed from user-specified proportions and confidence levels. In addition, the PROFILE program will, upon request, perform a worst case analysis for low solar insolation, low wind, or high wind periods. The revised weather data is written to a STAT file for subsequent use as input to the DSPA program.

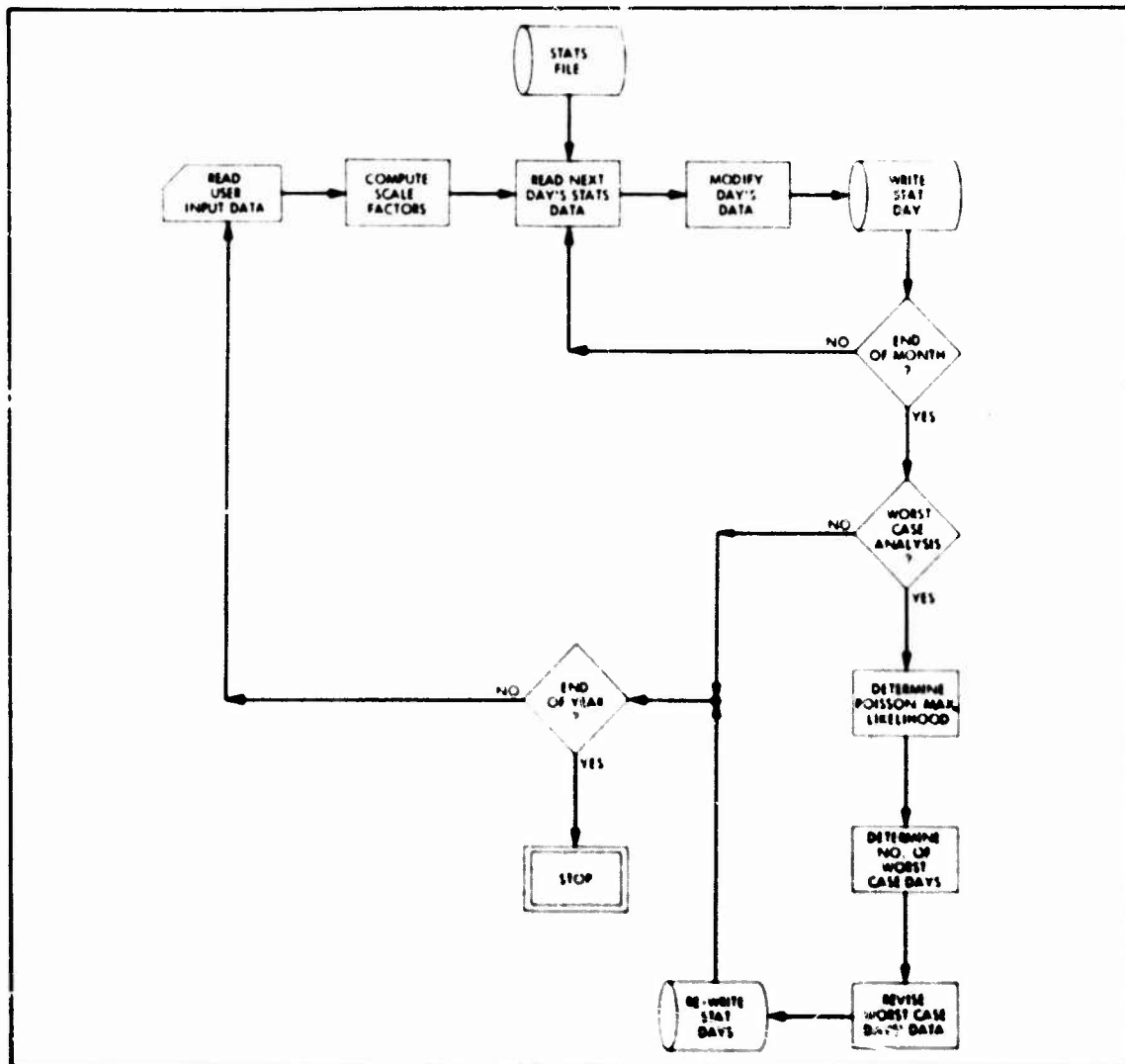

FIGURE 6-3. PROFILE COMPUTER PROGRAM

PROGRAM ALGORITHMSStep 1 Read monthly user input request

ALPHAQ = confidence level (0 to 1) for solar insolation data

ALPHAT = confidence level (0 to 1) for temperature data

ALPHAV = confidence level (0 to 1) for wind velocity data

ALPHHV = confidence level (0 to 1) for high wind worst case

ALPHLQ = confidence level (0 to 1) for low insolation worst
case

ALPHLV = confidence level (0 to 1) for low wind worst case

LH(1) = temperature flag: -1 = low profile

0 = means profile

+1 = high profile

LH(2) = wind velocity flag (-1, 0, or +1)

LH(3) = solar insolation flag (-1, 0, or +1)

LH(4) = low insolation flag: 0 = no worst case analysis

+1 = worst case analysis

LH(5) = low wind flag (0 or +1)

LH(6) = high wind flag (0 or +1)

PHV = scale factor (>1) for high wind worst case

PLQ = scale factor (0 to 1) for low insolation worst case

PLV = scale factor (0 to 1) for low wind worst case

PQ = proportion (0 to 1) for solar insolation data

PT = proportion (0 to 1) for temperature data

PV = proportion (0 to 1) for wind velocity data

Step 2 Compute tolerance limit factors

ZA = F{A,ZTABLE}

ZP = F{P,ZTABLE}

AL = $1.0 - ZA^{**2}/(2.0*(NYRS - 1))$

BL = $ZP^{**2} - ZA^{**2}/NYRS$

CL = $(ZP + SQRT(ZP^{**2} - AL*BL))/AL$

for each of CLT, CLV, and CLQ

where: A = specified confidence level
 P = specified proportion
 ZTABLE = table of inverse error function vs. percent
 CLT = temperature tolerance limit factor
 CLV = wind velocity tolerance limit factor
 CLQ = solar insolation tolerance limit factor

Step 3 Compute low/high delta/scale factors

DLHT = LH(1) * CLT * TM(2)
 RLHV = 1.0 + LH(2) * CLV * VM(2)/VM(1)
 RLHQ = 1.0 + LH(3) * CLQ * QM(2)/QM(1)

where: DLHT = temperature delta factor
 RLHV = wind velocity scale factor
 RLHQ = solar insolation scale factor
 TM(2) = monthly temperature standard deviation
 VM(1) = average monthly wind velocity
 VM(2) = monthly wind velocity standard deviation
 QM(1) = average monthly solar insolation
 QM(2) = monthly solar insolation standard deviation

Step 4 Read next STATS file day

T(I) = temperature for hour I
 V(I) = wind velocity for hour I
 Q(I) = solar insolation for hour I
 for I = 1,24

Step 5 Modify STATS data

T(I) = DLHT + T(I)
 V(I) = RLHV * V(I)
 Q(I) = RLHQ * Q(I)

Step 6 Write modified day's data to STAT file

Step 7 If: last day of month
 Then: GO TO STEP 8
 Otherwise: GO TO STEP 4

Step 8 If: worst case analysis requested
 Then: GO TO STEP 9
 Otherwise: GO TO STEP 13

Step 9 Compute Poisson maximum likelihood estimate
 LAMBDA = (SUM - CNT)/CNT
 for each of high wind, low wind, and low insolation

where: LAMBDA = maximum likelihood estimate
 SUM = total number of bad* days for current month
 CNT = number of strings of bad days for current
 month

Step 10 Compute number of sequential worst case days for current month

$$\text{NR such that } \frac{\sum_{J=1}^{\text{NR}} \text{LAMBDA}^{**J}/J!}{\sum_{J=1}^{\text{NDYS}} \text{LMBDA}^{**I}/I!} \geq \text{confidence level}$$

for each NRHV, NRLQ, NRLV

where: NDYS = number of days in current month
 NRHV = number of sequential high wind worst case days
 to be centered about the 20th day
 NRLQ = number of sequential low insolation worst
 case days to be centered about the 15th day
 NRLV = number of sequential low wind worst case
 days to be centered about the 10th day

*A bad day is a day for which $(Q \leq \text{PLQ} * Q_{\text{avg. for month}})$

Step 11 Modify worst case day's data for appropriate days of
 current month.

$V(I) = PLV * V(I)$ for low wind period

$Q(I) = PLQ * Q(I)$ for low insolation period

$V(I) PHV * V(I)$ for high wind period

Step 12 Re-write worst case days to STAT file

Step 13 If: last day of year

Then: GO TO STEP 14

Otherwise: TO TO STEP 1

Step 14 Stop Program