

AD-A047 982

LOCKHEED MISSILES AND SPACE CO INC PALO ALTO CALIF PA--ETC F/G 13/13
HYBRID STRUCTURES OF REVOLUTION.(U)

SEP 77 D BUSHNELL
LMSC-D564369

N00014-76-C-0692
NL

UNCLASSIFIED

1 of 1

ADAO47 982

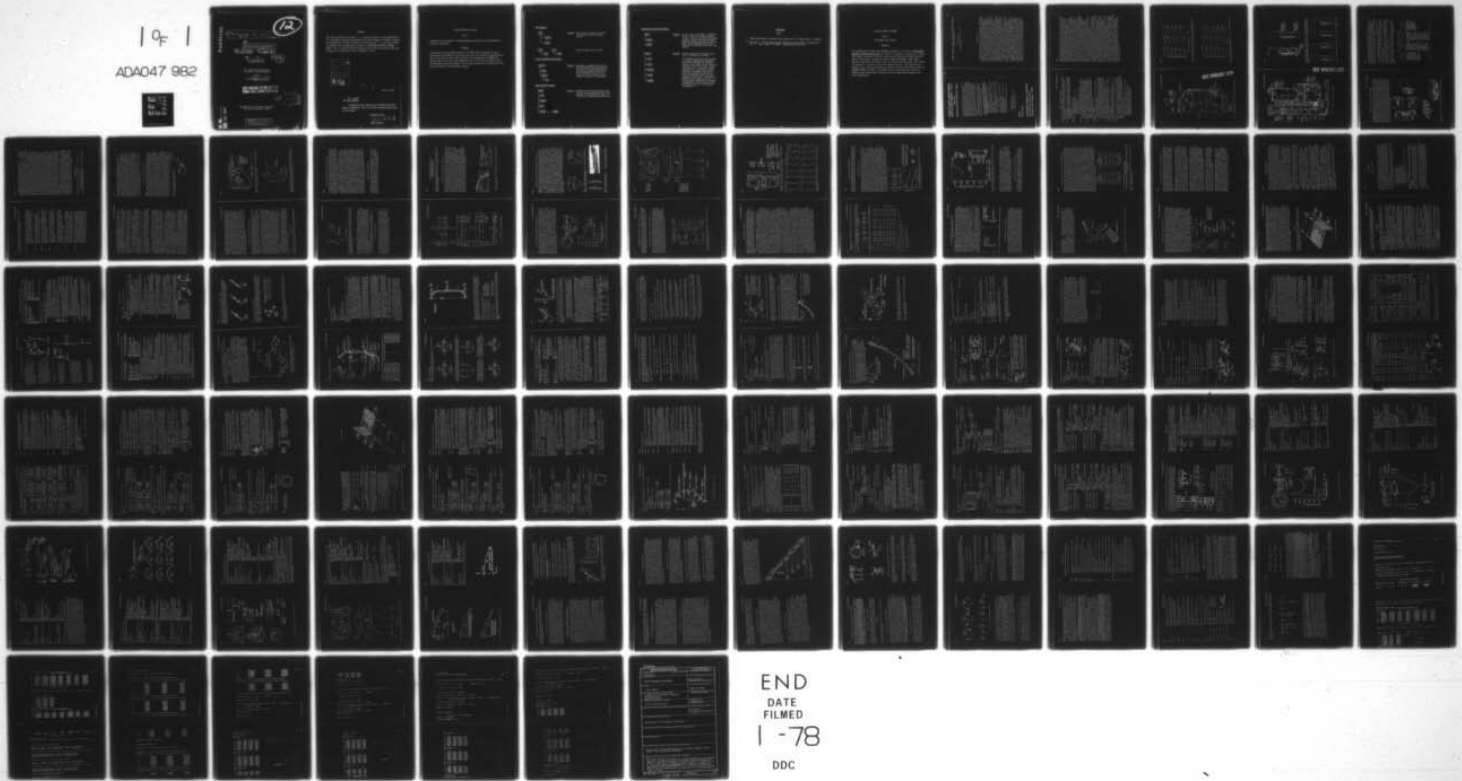

END
DATE
FILMED
1 -78
DDC

AD A 047982

12

9 Final rept. Jan 76 - Sep 77

6 HYBRID STRUCTURES OF REVOLUTION.

14 LMSC-D564369

11 September 1977

10 by David Bushnell

12 75 p.

This research was sponsored by The Office of Naval Research

15 under

Contract N00014-76-C-0692

COPY AVAILABLE TO DDC DOES NOT PERMIT FULLY LEGIBLE PRODUCTION

DDC RECEIVED DEC 22 1977

Lockheed Palo Alto Research Laboratory Palo Alto, California 94303

AD No. DDC FILE COPY

DISTRIBUTION STATEMENT A Approved for public release; Distribution Unlimited

210118

7/8

ABSTRACT

This report consists of two parts: 1. A brief description of the implementation of a new equation solving and eigenvalue extraction package into BOSOR6 (a program for the analysis of hybrid structures of revolution) and 2. a new User's Manual for BOSOR4, which has appeared as a chapter in STRUCTURAL MECHANICS SOFTWARE SERIES - VOL. 1, edited by Nicholas Perrone, Walter Pilkey and Barbara Pilkey and published by the University Press of Virginia in 1977.

ACCESSION FOR	
NTIS	White Section <input checked="" type="checkbox"/>
DDC	Soft Section <input type="checkbox"/>
UNANNOUNCED	<input type="checkbox"/>
JUSTIFICATION.....	
BY.....	
DISTRIBUTION/AVAILABILITY CODES	
Dist.	AVAIL. and/or SPECIAL
A	23 DIF

Nov. 30, 1977

Mr. Curdoff
Dear ~~Mrs. Taylor,~~

Enclosed are the originals for the final report for which DDC expressed a need for a better manuscript from which to make copies.

Sincerely yours,

David E. Bushnell

David Bushnell

Contract N00014-76-C-0692

Part I

Incorporation into BOSOR6 of a New Simultaneous Equation Solver and Eigenvalue Extraction Subroutines.

ABSTRACT

Subroutines written by Frank Brogan for the STAGS computer program [1] were incorporated into BOSOR6 [2] and check cases were run to debug the implementation. Most of the effort in this task was devoted to restructuring the BOSOR6 mass storage data files to make them compatible with the out-of-core equation solver and eigenvalue extraction package. The relevant subroutines are listed with their purposes defined on the following two pages.

DATA MANAGER

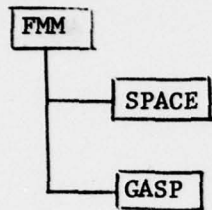

Purpose: Keeps track of data files stored on random access mass storage device.

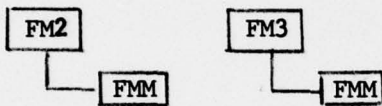

Special purpose calls to FMM.

MATRIX DECOMPOSITION ROUTINES

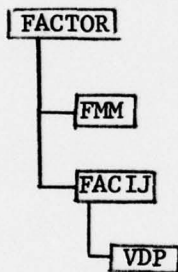

Purpose: Decomposes a symmetric matrix into lower and upper triangular factors. The matrix is stored in blocks on random access mass storage device. The data manager FMM is used to store and retrieve blocks of the symmetric matrix to be decomposed.

GLOBAL MATRIX ASSEMBLY

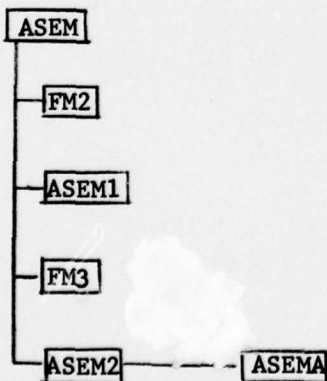

Purpose: Assembles the total stiffness matrix from the element stiffness file. This assembly is accomplished by means of a previously calculated skyline vector.

EIGENVALUE EXTRACTION ROUTINES

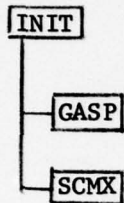

Purpose: Set up arrays of pointers to addresses of data in core or on mass storage device. These data include the element stiffness blocks, mass blocks, load-geometric blocks, assembled stiffness, mass, and load-geometric matrices, eigenvectors, skyline vector, and sign vector.

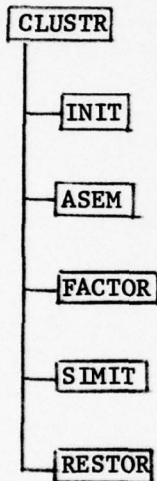

Purpose: Extract eigenvalues for modal vibrations or bifurcation buckling.

The CLUSTER program has been designed to solve the generalized eigenvalue problem $KX = \lambda BX$ when the equation system is very large and the number of eigenvalues desired is small, usually less than ten. A relatively simple combination of simultaneous inverse iteration, Chebyshev acceleration, and reduced eigenvalue solution provides an efficient method for most problems of this type. In particular, CLUSTER avoids additional shifts of the eigenvalue spectrum and consequent recomputation of the factored stiffness matrix except in a few special circumstances.

REFERENCES

PART I

1. STAGS Theory Manual; Currently being written by B. O. Almroth and F. A. Brogan.
2. Bushnell, D., "Stress, Buckling and Vibration of Hybrid Bodies of Revolution, Vol. II: User's Manual for BOSOR6", LMSC-D501504, March 1976.

Contract N00014-76-C-0692

PART II

New BOSOR4 User's Manual

ABSTRACT

The following User's Manual has appeared as Chapter 1, pp. 11-142 in Structural Mechanics Software Series, Vol. 1, edited by N. Perrone, W. Pilkey and B. Pilkey. This manual, an update of "Stress, Stability and Vibration of Complex Branched Shells of Revolution: Analysis and User's Manual for BOSOR4", LMSC report D243605, March 1972, was written, laid out, edited, and typed under this contract in response to a request by one of the contract monitors. This task was performed in lieu of the second objective stated in the July 1976 annual report for CONTRACT N00014-76-C-0692. The purpose of this second task was to make the BOSOR6 program capabilities conformable with the capabilities implied by the user documentation.

STRUCTURAL MECHANICS SOFTWARE SERIES - VOL I

Edited by

Nicholas Perrone and Walter Pilkey

The primary objective of this new series is to provide access for the technical community to structural analysis and design computer programs. These carefully selected programs are available on nationwide commercial computer networks and can be accessed by remote terminal devices connected via phone lines. While the associated computer program itself will not normally be published in the volumes, deck or tape copies will be made available via terminal devices or in some other convenient manner. The series contains sufficient documentation of the programs to permit their use on the national networks.

Another equally important role of this series is to inform readers of programs which are available on large, mini, and desk computers, and to provide a technical review or assessment of these programs.

PART I - SOFTWARE SERIES LIBRARY OF COMPUTER PROGRAMS
BOSOR4: Program for Stress, Buckling, and Vibration of Complex Shells of Revolution
GIFTS: Graphics Oriented Interactive Finite Element

Time-Sharing System
Interactive and Data Mode Preprocessor for SAP
TOTAL: Interactive Graphics System for the Two-dimensional Analysis of Linear Elastic Solids
BEAM: A Program for the Static, Stability, and Dynamic Response of Beams
BEAMSTRESS: A Program for Determining the Cross-sectional Properties and Stresses of a Bar
SHAFT: A Program for the Unbalanced Response and Critical Speeds of Rotating Shafts

PART II - REVIEWS AND SUMMARIES OF AVAILABLE PROGRAMS
Computer-Aided Building Design
Curved Girder Bridge Systems
Symbolic and Algebraic Manipulation Languages and Their Applications in Mechanics
Floor Analysis and Design
Three-dimensional Cross-motion Crash Victim Simulators

Editorial Office:
Applied Mechanics Division
School of Engineering and Applied Science
University of Virginia
Charlottesville, Virginia 22901

\$25.00

Order from:

UNIVERSITY PRESS of VIRGINIA
Box 3608 University Station
Charlottesville, Virginia 22903

BOSOR4: PROGRAM FOR STRESS, BUCKLING, AND VIBRATION OF COMPLEX SHELLS OF REVOLUTION

David Bushnell

Lockheed Missiles & Space Co., Inc.

INTRODUCTION

A comprehensive computer program, designated BOSOR4, for analysis of the stress, stability and vibration of segmented, ring-stiffened, branched shells of revolution and prismatic shells and panels is described. The program performs large-deflection axisymmetric stress analysis, small-deflection nonsymmetric stress analysis, modal vibration analysis with axisymmetric nonlinear prestress included, and buckling analysis with axisymmetric or nonsymmetric prestress. One of the main advantages of the code is the provision for realistic engineering details such as eccentric load paths, internal supports, arbitrary branching conditions, and a 'library' of wall constructions. The program is based on the finite difference energy method which is very rapidly convergent with increasing numbers of mesh points. Overlay charts and core storage requirements are given for the CDC 6600, IBM 370/165, and UNIVAC 1108/1110 versions of BOSOR4. Several examples are included to demonstrate the scope and practicality of the program. Some hints are given to help the user generate appropriate analytical models. An appendix contains the user's manual for BOSOR4.

Table 1 shows the characteristics and status of BOSOR4. The program is currently in widespread use and is maintained by the developer. Notices of any bugs found are promptly circulated to all known users and data centers that have acquired BOSOR4.

The BOSOR4 program was developed in response to the need for a tool which would help the engineer to design practical shell structures. An important class of such shell structures includes segmented, ring-stiffened branched shells of revolution. These shells may have various meridional geometries, wall constructions, boundary conditions, ring reinforcements, and types of loading, including thermal loading. An example is shown in Fig. 1. The meridian of the shell of revolution consists of six segments with various geometries and wall constructions. The first segment (nearest the bottom, end "A") is a monocoque ogive with variable thickness; the second is a conical shell with three layers of

Table 1 BOSOR4 at a Glance

Keywords: shells, stress, buckling, vibration, nonlinear, elastic, shells of revolution, ring-stiffened, branched, composites, discrete model

Purpose: To perform stress, buckling, and modal vibration analyses of ring-stiffened, branched shells of revolution loaded either axisymmetrically or nonsymmetrically. Complex wall construction permitted.

Date: 1972; most recent update 1975

Developer: David Bushnell, 52-33/205

Lockheed Missiles & Space Co., Inc.

3251 Hanover Street

Palo Alto, Ca. 94304

Tel: (415) 493-4411, X45491 or 43851

Method: Finite difference energy minimization; Fourier superposition in circumferential variable; Newton method for solution of nonlinear axisymmetric problem; inverse power iteration with spectral shifts for eigenvalue extraction; Lagrange multipliers for constraint conditions; thin shell theory.

Restrictions: 1500 degrees of freedom (d.o.f.) in nonaxisymmetric analysis; 1000 d.o.f. in axisymmetric prebuckling stress analysis; Maximum of 20 Fourier harmonics per case; Knockdown factors for imperfections not included; Radius/thickness should be greater than about 10.

Language: FORTRAN IV

Documentation: BOSOR4 User's Manual [1] and about 10 journal

articles with numerous examples.

Input: Preprocessor written by SKD Enterprise, 9138 Barberry Lane, Hickory Hills, Illinois 60457 for free-field input. Required for input are shell segment geometries, ring geometries, number of mesh points, ranges and increments of circumferential wave numbers, load and temperature distributions, shell wall construction details, and constraint conditions.

Output: Stress resultants or extreme fiber stresses, buckling

loads, vibration frequencies; list and plots.

Hardware: UNIVAC 1108/110, CDC 6600/7600, IEM 360/370; SC4020 and

CALCOMP plotters

Usage: About 100 institutions have obtained BOSOR4. It is cur-

rently being used on a daily basis by many of them.

Run Time: Typically a job will require 1-10 minutes of computer time.

Availability: CDC and UNIVAC versions from developer (see above);

IEM version from Prof. Victor Weingarten, Dept. of Civil Eng., Univ. of Southern Calif., University Park, Los Angeles, Calif. 90007; Price: \$300. In addition to the Software Series participating networks mentioned in this volume, BOSOR4 may be run through the following data centers:

McDonnell-Douglas Automation, Huntington Beach, Calif.

Control Data Corp., Rockville, Md.

Westinghouse Telecomputer, Pittsburgh, Penna.

Information System Design, Oakland, Calif.

Boeing Computer Service, Seattle, Wash.

temperature-dependent, orthotropic material; the third is a layered, fiber-wound cylinder; the fourth is a toroidal segment with eccentric rings and stringers; the fifth is a spherical segment with eccentric rings and stringers; and the sixth is a flat plate with sandwich construction and eccentric meridional stiffeners. The reference surface is indicated by the dark dash-dot line. It is seen that the meridian of the composite shell structure is discontinuous between the first and second segments, the second and third segments, and the third and fourth segments. In the analysis these discontinuities are accounted for. The shell is supported at the end "A" by a ring which is restrained as shown: axial and radial displacements u^* and w^* are not permitted at the point "A", which is located a specified distance from the beginning of the reference surface. In the analysis of actual shell structures it is important that support points, junctures, and ring reinforcements be accurately modeled. Seemingly insignificant parameters sometimes have a large effect on the stress, buckling loads, and vibration frequencies. The shell is reinforced by 6 rings of rectangular cross section, the centroids of which are shown in the figure. These rings are treated as discrete elastic structures in the analysis. The shell is submitted to uniform external pressure (not shown), line loads applied at the first and second rings, and the thermal environment depicted on the second segment.

Figures 2 and 3 show computer-generated plots from a linear buckling analysis and free vibration analysis. Normal displacement components w of the modes are shown for the lowest three eigenvalues corresponding to circumferential harmonics $n = 4, 6, 8, 10, 12$ and 14. The regions of the six shell segments are indicated in Fig. 2. In the buckling analysis the uniform pressure is the eigenvalue parameter, all other mechanical and thermal loads being held fixed. In the vibration analysis the external pressure is 40 psi and all loads are held fixed. Calculation of the 18 eigenvalues requires 8 min for the buckling analysis and 6 min for the vibration analysis. Computations were performed on the UNIVAC 1108, in double precision. There are 460 degrees of freedom in the discrete model.

BOSOR4 has been in use at Lockheed and elsewhere since 1972. During that time it has been used in several projects, some of them involving rather complex shells of revolution. An example is shown in Fig. 4, which depicts a somewhat idealized model of a cryogenic cooler. The axisymmetric structure consists of a series of fiberglass tubes from which are suspended two axisymmetric cryogenic tanks. The object of this study was to determine the natural frequencies of the cooler corresponding to beam-type modes ($n=1$ circumferential wave). The discretized model is shown in Fig. 5 and the first four vibration modes in Fig. 6.

SCOPE OF THE BOSOR4 COMPUTER PROGRAM

The BOSOR4 code performs stress, stability, and vibration analyses of segmented, branched, ring-stiffened, elastic shells of revolution with various wall constructions. Figure 7 shows some examples of branched structures which can be handled by BOSOR4. Figure 7a represents part of a multiple-stage rocket treated as a shell of seven segments; Fig. 7b represents part of a ring-stiffened cylinder in which the ring is treated as two shell segments branching from the cylinder; Fig. 7c shows the same ring-stiffened cylinder, but with the ring treated as 'discrete', that is the ring cross section can rotate and translate but not deform, as it can in the model shown in Fig. 7b. Figures 7d-f represent branched prismatic shell structures, which can be treated as shells of revolution with very large mean circumferential radii of curvature, as described in [2] and later in this paper.

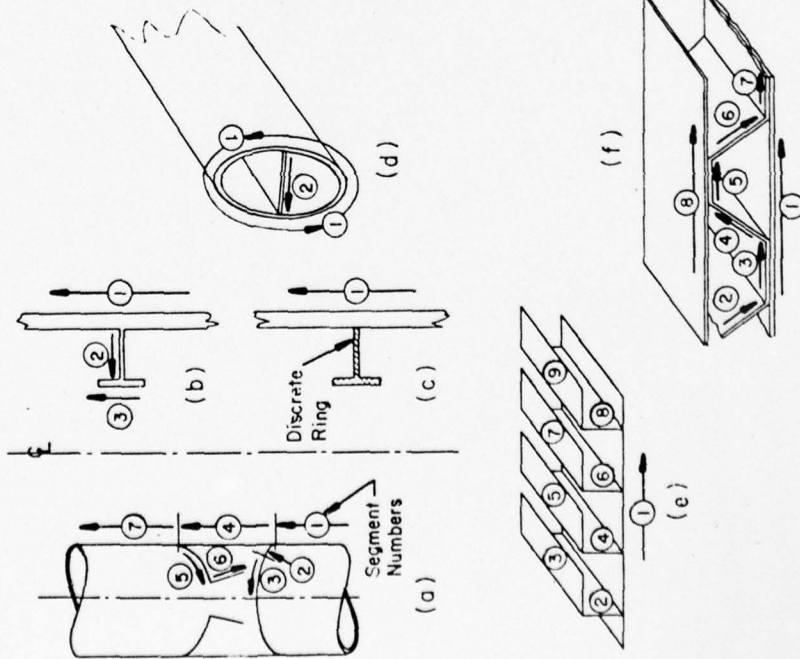

Fig. 7 Examples of branched structures which can be analyzed with BOSOR4

The program is very general with respect to geometry of meridian, shell-wall design, edge conditions, and loading. It has been thoroughly checked out by comparisons with other known solutions and tests and by extensive use at a number of different institutions over the past three years. The BOSOR4 capability is summarized in Table 2. The code represents three distinct analyses:

1. A nonlinear stress analysis for axisymmetric behavior of axisymmetric shell systems (large deflections, elastic)
2. A linear stress analysis for axisymmetric and nonsymmetric behavior of axisymmetric shell systems submitted to axisymmetric and nonsymmetric loads
3. An eigenvalue analysis in which the eigenvalues represent buckling loads or vibration frequencies of axisymmetric shell systems submitted to axisymmetric loads. (Eigenvectors may correspond to axisymmetric or nonsymmetric modes.)

BOSOR4 has an additional branch corresponding to buckling of non-symmetrically loaded shells of revolution. However, this branch is really a combination of the second and third analyses just listed.

Table 2 BOSOR4 Capability Summary

Type of analysis	Shell geometry	Wall construction	Loading
Nonlinear axisymmetric stress	Multiple-segment shells, each segment with its own wall construction, geometry, and loading	Monocoque, variable or constant thickness	Axisymmetric or non-axisymmetric thermal and/or mechanical line loads and moments
Linear symmetric or nonsymmetric stress	Cylinder, cone, spherical, ogival, toroidal, ellipsoidal, etc.	Skew-stiffened shells Fiber-wound shells Layered orthotropic shells	Axisymmetric or non-axisymmetric thermal and/or mechanical distributed loads
Stability with linear symmetric or nonsymmetric prestress or with nonlinear symmetric prestress	General meridional shape; point-by-point input	Corrugated, with or without skin Layered orthotropic with temperature-dependent material properties	Proportional loading Non-proportional loading
Vibration with nonlinear prestress	Arbitrary choice of meridian reference surface	Any of above wall types reinforced by stringers and/or "smeared out"	
Variable mesh point spacing within each segment	General edge conditions Branched shells Prismatic shells and composite built-up panels	Any of above wall types further reinforced by rings treated as discrete	

In the BOSOR4 code, the user chooses the type of analysis to be performed by means of a control integer INDIC:

- INDIC = -2 Stability determinant calculated for given circumferential wave number N for increasing loads until it changes sign. Nonlinear prebuckling effects included. INDIC then changed automatically to -1 and calculations proceed as if INDIC has always been -1.
- INDIC = -1 Buckling load and corresponding wave number N determined, including nonlinear prebuckling effects. N corresponding to local minimum critical load $L_{cr}(N)$ is automatically sought.
- INDIC = 0 Axisymmetric stresses and displacements calculated for a sequence of stepwise increasing loads from some starting value to some maximum value, including nonlinear effects. Axisymmetric collapse loads can be calculated.
- INDIC = 1 Buckling loads calculated with nonlinear bending theory for a fixed load. Buckling loads calculated for a range of circumferential wave numbers. Several buckling loads for each wave number can be calculated.
- INDIC = 2 Vibration frequencies and mode shapes calculated, including the effects of prestress obtained from axisymmetric nonlinear analysis. Several frequencies and modes can be calculated for each circumferential wave number.
- INDIC = 3 Nonsymmetric or symmetric stresses and displacements calculated for a range of circumferential wave numbers. Linear theory used. Results for each harmonic are automatically superposed. Fourier series for nonsymmetric loads are automatically computed or may be provided by user.
- INDIC = 4 Buckling loads calculated for nonsymmetrically loaded shells. Prebuckled state obtained from linear theory (INDIC = 3) or read in from cards. 'Worst' meridional prestress distribution (such as distribution involving maximum negative meridional or hoop prestress resultant) chosen by user, and this particular distribution is assumed to be axisymmetric in the stability analysis, which is the same as that for the branch INDIC = 1.

The variety of buckling analyses (INDIC = -2, -1, 1, and 4) is to permit the user to approach a given problem in a number of different ways. There are cases for which an INDIC = -1 analysis, for example, will not work. The user can then resort to an INDIC = -2 analysis, which requires more computer time, but which is generally more reliable. Buckling of a shallow spherical cap under external pressure is an example. In an INDIC = -1 analysis of the cap, the program generates a sequence of loads that ordinarily should converge to the lowest buckling load, with nonlinear prebuckling effects included. Depending on the cap geometry and the user-provided initial pressure, however, one of the loads in the sequence may exceed the axisymmetric collapse pressure of the cap. This phenomenon can occur if the bifurcation buckling loads are just slightly smaller than the axisymmetric collapse loads. The user can obtain a solution with use of INDIC = -2, in which the bifurcation load is approached from below in a 'gradual' manner.

The branch INDIC = 1 is provided because it is sometimes desirable to know several buckling eigenvalues for each circumferential wave number, N, and because there may exist more than one minimum in the critical load vs N-space. This is especially true for composite shell structures with many segments and load types. Such a structure can buckle in many different ways. The designer may have to eliminate several possible failure modes, not just the one corresponding to the lowest pressure, for example. The INDIC = 4 branch is provided for two reasons: The user can calculate buckling under nonsymmetric loads without having to make two separate runs, an INDIC = 3 run and an INDIC = 1 run. In addition, this branch permits the user to bypass the prebuckling analysis and read prebuckling stress distributions and rotations directly from cards. This second feature is very useful for the treatment of composite branched panels under uniaxial or biaxial compression.

The BOSOR4 program, although applicable to shells of revolution, can be used for the buckling analysis of composite, branched panels by means of a 'trick' described in detail in Ref [2]. This 'trick' permits the analysis of any prismatic shell structure that is simply-supported at particular stations along the length. Any boundary conditions can be used along generators. In [2] many examples are given, including nonuniformly loaded cylinders, non-circular cylinders, corrugated panels, and cylinders with stringers treated as discrete. This paper gives other examples.

ANALYSIS METHOD

The assumptions upon which the BOSOR4 code is based are:

1. The wall material is elastic.
2. Thin shell theory holds; i.e. normals to the undeformed surface remain normal and undeformed.

3. The structure is axisymmetric, and in vibration analysis and nonlinear stress analysis the loads and prebuckling or pre-stress deformations are axisymmetric.
4. The axisymmetric prebuckling deflections in the nonlinear theory (INDIC = 0, -1, 2), while considered finite, are moderate; i.e. the square of the meridional rotation can be neglected compared with unity.
5. In the calculation of displacement and stresses in non-symmetrically loaded shells (INDIC = 3), linear theory is used. This branch of the program is based on standard small-deflection analysis.
6. A typical cross sectional dimension of a discrete ring stiffener is small compared with the radius of the ring.
7. The cross sections of the discrete rings remain undeformed as the structure deforms, and the rotation about the ring centroid is equal to the rotation of the shell meridian at the attachment point of the ring (except, of course, if the ring is treated as a flexible shell branch).
8. The discrete ring centroids coincide with their shear centers.
9. If meridional stiffeners are present, they are numerous enough to include in the analysis by an averaging or 'smearing' of their properties over any parallel circle of the shell structure. Meridional stiffeners can be treated as discrete through the 'trick' described in Ref. [2].

The analysis is based on energy minimization with constraint conditions. The total energy of the system includes strain energy of the shell segments and discrete rings, potential energy of the applied line loads and pressures, and kinetic energy of the shell segments and discrete rings. The constraint conditions arise from displacement conditions at the boundaries of the structure, displacement conditions that may be prescribed anywhere within the structure, and at junctures between segments. The constraint conditions are introduced into the energy function by means of Lagrange multipliers.

These components of energy and constraint conditions are initially integro - differential forms. The circumferential dependence is eliminated by separation of variables. Displacements and meridional derivatives of displacements are then written in terms of the shell reference surface components u_i , v_i and w_i at the finite-difference mesh points and Lagrange multipliers λ_i . Integration is performed simply by multiplication of the energy per unit length of meridian by the length of the 'finite difference element', to be described below.

In the nonlinear axisymmetric stress analysis the energy expression has terms linear, quadratic, cubic, and quartic in the dependent variables u_i and w_i . The cubic and quartic energy terms arise from the rotation-squared terms that appear in the expression for reference surface meridional strain and in the constraint conditions. Energy minimization leads to a set of nonlinear algebraic equations that are solved by the Newton-Raphson method. Stress and moment resultants are calculated in a straightforward

manner from the mesh-point displacement components through the constitutive equations and the kinematic relations.

The results from the nonlinear axisymmetric or linear non-symmetric stress analysis are used in the eigenvalue analyses for buckling and vibration. The 'prebuckling' or 'prestress' meridional and circumferential stress resultants N_{10} and N_{20} and the meridional rotation χ_0 appear as known variable coefficients in the energy expressions that govern buckling and vibration. These expressions are homogeneous quadratic forms. The values of a parameter (load or frequency) that render the quadratic forms stationary with respect to infinitesimal variations of the dependent variables represent buckling loads or natural frequencies. These eigenvalues are calculated from a set of linear homogeneous equations. More will be written about the bifurcation buckling eigenvalue problems in the following paragraphs.

Details of the analysis are given in [1, 3 and 4]. Only two aspects will be described here: the finite difference element and the stability eigenvalue problem.

The 'Finite Difference' Element

BOSOR4 is based on the finite difference energy method. This method is described in detail and compared with the finite element method in [5]. Figure 8 shows a typical shell segment meridian with finite difference mesh points. The 'u' and 'v' points are located halfway between adjacent 'w' points. The energy contains up to first derivatives in u and v and up to second derivatives in w. Hence, the shell energy density evaluated at the point labeled E (center of the length ℓ) involves the seven points w_{i-1} through w_{i+1} . The energy per unit circumferential length is simply the difference element ℓ , which is the arc length of the reference surface between two adjacent u or v points. In Ref. [5] it is shown that this formulation yields a 7 x 7 stiffness matrix corresponding to a constant strain, constant curvature change finite element that is incompatible in normal displacement and rotation at its boundaries but that in general gives very rapidly convergent results with increasing density of nodal points. Note that two of the w points lie outside of the element. If the mesh spacing is

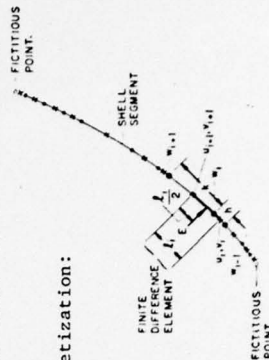

Fig. 8 Finite difference discretization: the 'finite difference element'

constant, the algebraic equations obtained by minimization of the energy with respect to nodal degrees of freedom can be shown to be equivalent to the Euler equations of the variational problem in finite form. Further description and proofs are given in Ref. [5].

Figures 9 and 10 show rates of convergence with increasing nodal point density for a poorly conditioned problem - a stress analysis of a thin, nonsymmetrically loaded hemisphere with a free edge. The finite element results were obtained by programming various kinds of finite elements into BOSOR4. The computer time for computation of the stiffness matrix K_I is shown in Fig. 10. A much smaller time for computation of the finite difference K_I is required because there are fewer calculations for each Gaussian integration point and because there is only one Gaussian point per finite difference element. Other comparisons of rate of convergence with the two methods used in BOSOR4 are shown for buckling and vibration problems in Ref. [5].

Formulation of the Stability Problem

The bifurcation buckling problem represents perhaps the most difficult of the three types of analyses performed by BOSOR4. It is practical to consider bifurcation buckling of complex, ring stiffened shell structures under various systems of loads, some of which are considered to be known and constant, or 'fixed' and some of which are considered to be unknown eigenvalue parameters, or 'variable'.

The notion of 'fixed' and 'variable' systems of loads not only permits the analysis of structures submitted to nonproportionally varying loads, but also helps in the formulation of a sequence of simple or 'classical' eigenvalue problems for the solution of problems governed by 'nonclassical' eigenvalue problems. An example is a shallow spherical cap under external pressure. Very shallow caps fail by nonlinear collapse, or snap-through buckling, not by bifurcation buckling. Deep spherical caps fail by bifurcation buckling in which nonlinearities in prebuckling behavior are not particularly important. There is a range of cap geometries for which bifurcation buckling is the mode of failure and for which the critical pressures are much affected by nonlinearities in prebuckling behavior. The analysis of this intermediate class of spherical caps is simplified by the concept of 'fixed' and 'variable' pressure.

Figure 11 shows the load deflection curve of a shallow cap in this intermediate range. Nonlinear axisymmetric collapse (pnl), linear bifurcation (plb), and nonlinear bifurcation (pnb) loads are shown. The purpose of the analysis referred to in this section is to determine the pressure p_{nb} . It is useful to consider the pressure p_{nb} as composed of two parts

$$p_{nb} = p^f + p^v$$

in which p^f denotes a known or 'fixed' quantity, and p^v denotes an undetermined or 'variable' quantity. The fixed portion p^f is an

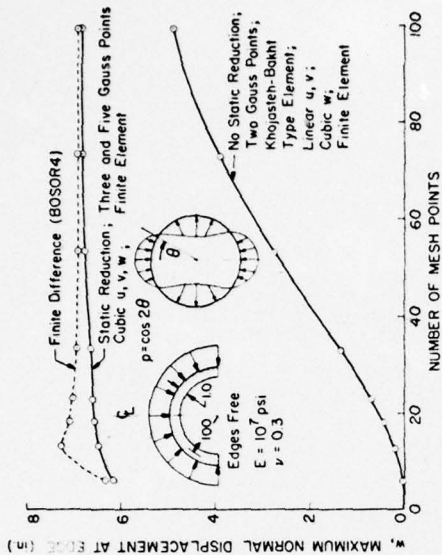

Fig. 9 Normal displacement at free edge of hemisphere with non-uniform pressure $p(s, \theta) = p_0 \cos 2\theta$

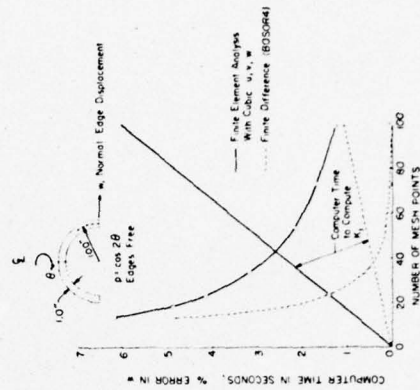

Fig. 10 Computer times to form stiffness matrix K_I and rates of convergence of normal edge displacement for free hemisphere with nonuniform pressure $p(s, \theta) = p_0 \cos 2\theta$

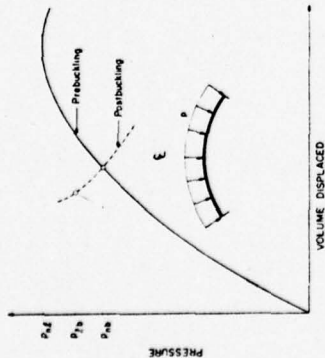

Fig. 11 Load deflection curves for shallow spherical cap, showing bifurcation points from linear prebuckling curve (p_b) and nonlinear prebuckling curve (p_n)

initial guess or represents the results of a previous iteration. The variable portion p_v is the remainder, which can be determined from an eigenvalue problem, as will be described. It is clear from Fig. 11 that if p_f is fairly close to p_n the behavior in the range $p = p_f \pm p_v$ is reasonably linear. Thus, the eigenvalue p_n can be calculated by means of a sequence of eigenvalue problems through which ever and ever smaller values p_v are determined and added to the known results p_f from the previous iterations. As the BOSOR4 computer program is written the initial guess p_f need not be close to the solution p_n .

In the bifurcation stability analysis it is necessary to develop two matrices corresponding to the eigenvalue problem

$$K_1(n)x_n + \lambda_n K_2(n)x_n = 0. \quad (1)$$

In Eq. (1) $K_1(n)$ is the stiffness matrix of the shell as loaded by the fixed load system p_f ; $K_2(n)$ is the load-geometric matrix corresponding to the prestress increment caused by the loading increment p_v ; λ_n is the eigenvalue; x_n is the eigenvector; and n is the number of full circumferential waves. Eigenvalues are extracted by inverse power iterations with spectral shifts. Further details of the theory are given in [6], including the treatment of the discrete ring stiffeners and constraint conditions.

IMPERFECTION SENSITIVITY IN BUCKLING ANALYSES

It is well known that the load-carrying capability of thin shells is in many cases sensitive to initial imperfections of the geometry of the shell wall. The question so often asked by the analyst is: given the idealized structure and loading, and given the means by which to determine the collapse or bifurcation buckling loads, what "knockdown" factor should be applied to assure a reasonable factor of safety for the actual imperfect structure?

In Fig. 15 is an example of a shell-load system which exhibits load carrying capability considerably greater than that corresponding to the lowest bifurcation eigenvalue. Postbuckling stability is also exhibited by columns and flat plates. On the other hand, it is well known that the critical loads of axially compressed cylindrical shells and externally pressurized spherical shells are extremely sensitive to imperfections less than one wall thick in magnitude. These highly symmetrical systems are very sensitive to imperfections because many different buckling modes are associated with the same eigenvalue, the structure is uniformly compressed in a membrane state, and the buckling modes have many small waves. Very small local imperfections will tend to trigger premature failure. The buckling loads of most practical shell structures are somewhat sensitive to imperfections, but not this sensitive. How much so is a very important question. BOSOR4 does not calculate "knock down" factors to account for imperfections. With BOSOR4 the analyst can calculate buckling loads of shells with arbitrary axisymmetric imperfections. The BOSOR4 user is urged to read the brief survey of imperfection sensitivity theory given in [7] and to consult the references given there.

BOSOR4 PROGRAM ORGANIZATION

The BOSOR4 program consists of a main program MAIN and six overlays called READIT, PRE, ARRAYS, BUCKLE, MODEL, AND PLOTI. Figure 12 gives the core storage in decimal words required for the Univac 1108, IBM 370, and CDC 6600 versions of BOSOR4. The Univac 1108 and IBM 370 versions are written in double precision FORTRAN IV; the CDC version is written in single precision FORTRAN IV.

SAMPLE DESIGN PROBLEMS FOR WHICH BOSOR4 HAS BEEN USED AND COMPARISON WITH TESTS

A complex design that BOSOR4 was used on is shown in Fig. 4. Other examples corresponding to various analysis branches (INDIC) are given in this section.

Nonlinear Stress Analysis (INDIC = 0)

Figure 13 shows part of an internally pressurized elliptical tank which has been thickened locally near the equator for welding. The engineering drawings called for an elliptically shaped inner surface with the thickness varying as shown. The maximum stress occurs at the outer fiber at point C because there is considerable local bending there due to the rather sudden change in direction, or eccentricity, of the load path in the short segment ACB. The nonlinear theory gives lower stresses than the linear theory because the meridional tension causes the tank to change shape in such a way as to decrease the local excursion of the load path, thereby decreasing the effective bending moment acting at point C. The tank had been built and a linear analysis performed. The user of the tank wanted to know if it would withstand a somewhat higher internal pressure than that for which it had originally been designed. The lower stress predicted with nonlinear theory gave him enough margin of safety to avoid the necessity of redesign.

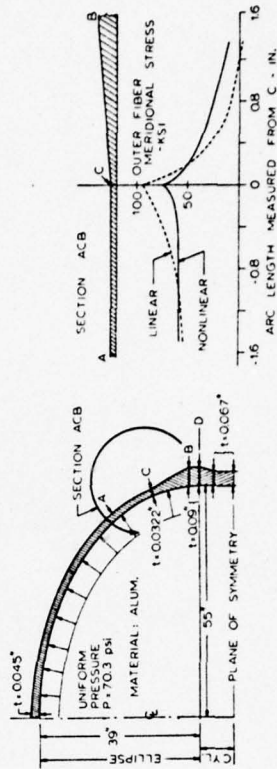

Fig. 13 Linear and nonlinear analysis of internally pressurized elliptical tank

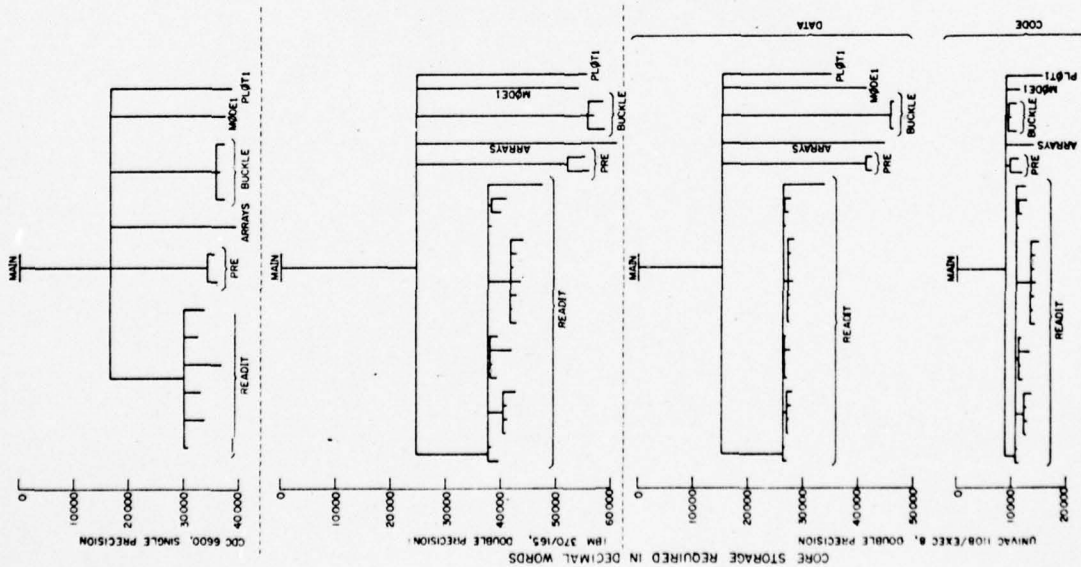

Fig. 12 BOSOR4 core storage requirements

T-ring Modeled as Branched Shell (INDIC = 0)

Figure 14 shows the discretized model and buckling loads predicted for a range of circumferential waves N. BOSOR4 gives two minima in the range $2 \leq N \leq 16$. The minimum at $N = 2$ is a mode in which the cross section does not deform, i.e. the ring ovalization mode. Buckling pressures calculated for this mode are very close to those computed from the well known formula $q_{cr} = EI(N^2 - 1)/rc^3$, in which q_{cr} is the critical line load in lb/in. (pressure integrated in the direction of segment 1), EI is the bending rigidity of the ring, and rc is the radius to the ring centroidal axis. The minimum at about $N = 11$ corresponds to buckling of the web. In a test the web crumpled at about 1500 psi. The $N = 2$ mode was not observed because the ring was held in a mandrel that prevented the unlimited growth of this mode. Approximately 20 sec of UNIVAC 1108 CPU time were required for this case.

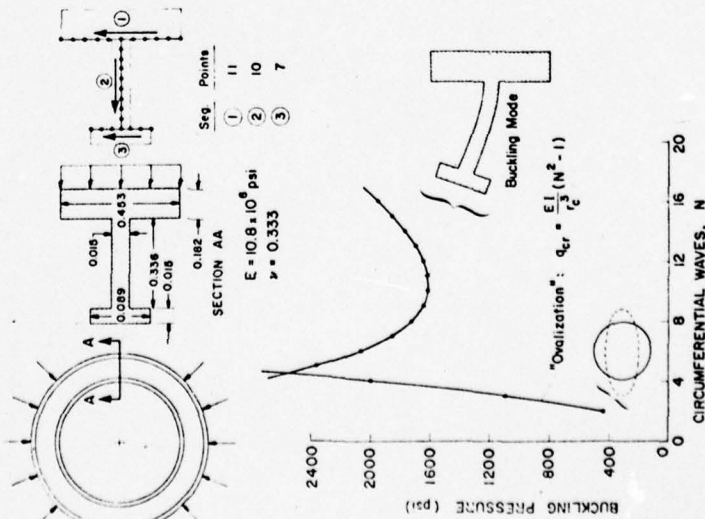

Fig. 14 Buckling of ring treated as branched shell

Nonlinear Bifurcation Buckling (INDIC = -2 and -1)

Point-loaded spherical caps were tested by Penning and Thurston in 1965 [8]. A configuration and predicted and experimental load-deflection curves with bifurcation points are shown in Fig. 15. This system is stable at and beyond the bifurcation points shown.

Figure 16 depicts a short section of the generator of a cylinder stiffened by external corrugations. The corrugations are cut away in the neighborhood of a field joint ring to allow for bolting of the two mating flanges of the ring. The cylinder is axially compressed. Far away from the field joint the axial resultant acts through the centroid of the corrugation-skin combination. In the neighborhood of the field joint the load path moves radially inward, effectively causing an axisymmetric dimple. As the axial compression is increased, hoop compressive stresses build up in the regions reinforced by doublers. Slight asymmetry of the assembly causes the ring to roll over axisymmetrically, which generates higher compressive hoop stresses above the ring and eventually leads to buckling there with many small waves around the circumference of the cylinder. Figure 17 shows the actual failure, which agrees with the BOSOR4 prediction.

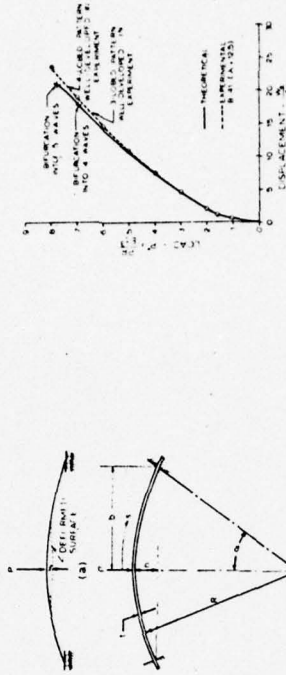

Fig. 15 Point-loaded spherical cap and load-deflection curves obtained from test and from BOSOR4

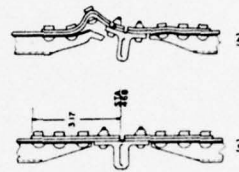

Fig. 16 Field joint geometry and buckle under axial load



Fig. 17 Failure as seen from inside the corrugated cylinder

Nonsymmetric Linear Stress Analysis (INDIC = 3)

Figure 18 gives thermal stresses in a cylinder configured and heated nonsymmetrically as shown. The test results are from [9]. Twenty Fourier harmonics were used for representation of the circumferential temperature distribution and calculation of the stress.

Buckling Under Nonsymmetric Loading (INDIC = 4)

Figures 19 and 20 show the model and results. Figure 19 gives the observed temperature rise distribution at buckling as reported in [10]. Figure 20 shows the predicted prebuckling stress and displacement distributions and the lowest three eigenvalues and eigenvectors corresponding to 20 circumferential waves. The eigenvalues denote a factor to be multiplied by the prebuckling temperature rise distribution at buckling in the test. Twenty Fourier harmonics were used for the prebuckling analysis. The model consists of 309 degrees of freedom. A total of 74 sec of CPU time on the UNIVAC 1108 were required for execution of the case.

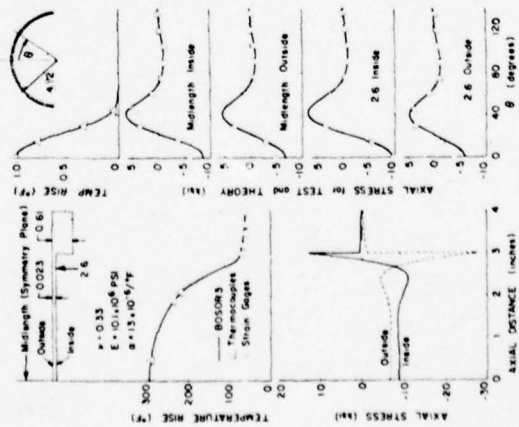

Fig. 18 Comparison of test and theory for thermal stress in non-symmetrically heated cylinder

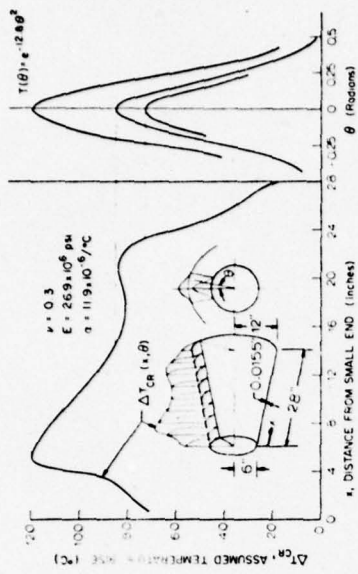

Fig. 19 Conical shell heated along axial strip

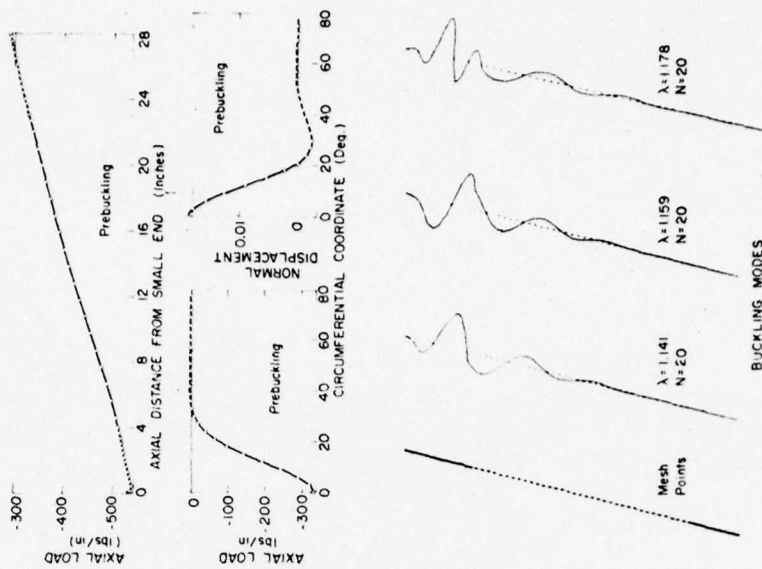

Fig. 20 Prebuckling state of non-axisymmetrically heated cone and buckling modes

Modal Vibration (INDIC = 2)

Figures 21 and 22 show the geometry and some natural vibration modes of an aluminum ring stiffened cylinder supported by steel end plates. The cylinder was tested by Hayek and Pallett [11] and a previous analysis was performed by Harari and Baron [12]. The experimental results, analytical results from BOSOR4 with eight different models, and analytical results from [12] are given in Table 3.

One of the most important points to be made in regard to Table 3 is that an approximate analysis can be fortuitous coincidence yield very good results because of counteracting errors. Take the bottom row of Table 3, for example. The relatively crude model in which the rings are treated as discrete and the end plates are omitted (modeled as simple supports--v and w restrained, u and rotation free) leads by chance to a very good prediction (2800 cps) of the experimental result (2802 cps). However, the stiffness of each discrete ring is overestimated because its cross section is not permitted to deform. If each ring is treated as a shell segment with no other changes made in the model, a new frequency of 2663 cps is obtained. This branched model is labeled (1) in Fig. 21b. If an additional refinement is made by the addition of the end plates, frequencies of 2682 or 2724 cps are obtained, depending on the degree of constraint assumed to exist between the end plates and the cylinder. These models are too flexible, however, because axial bending of the cylinder wall is permitted along the 0.375 in. lengths corresponding to the regions of intersection of cylinder and rings. If the cylinder is treated as consisting of six segments with 0.375 in. gaps at the areas where the rings and cylinder intersect, and if the material in each gap is treated as a discrete ring with undeformable cross section, the frequencies of 2750 or 2782 or 2833 cps are calculated, depending on whether the end plates are included and, if they are, on the degree of constraint assumed to exist between them and the cylinder. This segmented cylinder model is labeled (2) in Fig. 21b. The predicted vibration mode shapes with $n = 6, m = 3$ for all of the models are given in Fig. 22. The test frequency of 2802 cps is bracketed by the results from the various models. Notice that for other modes the test frequencies are less well predicted by the cruder discrete ring model but that they are still bracketed (with the exception of $n = 5, m = 1$) by use of the full range of models as just described. The case $n = 6, m = 1$ is an example. In the $n = 1$ case it is important to include the end plates in order to obtain an accurate prediction of the fundamental beam bending mode of the entire free-free cylinder end plate system. This mode is depicted in Fig. 22. During the study of a particular structure the analyst should set up various models in order to obtain upper and lower bounds on the behavior if possible. Because of imperfections, it is difficult to obtain a lower bound for buckling loads. However, since vibration frequencies and modes are not sensitive to imperfections, vibration test results can usually be regarded as reliable and can therefore be used to determine which models best simulate the actual behavior.

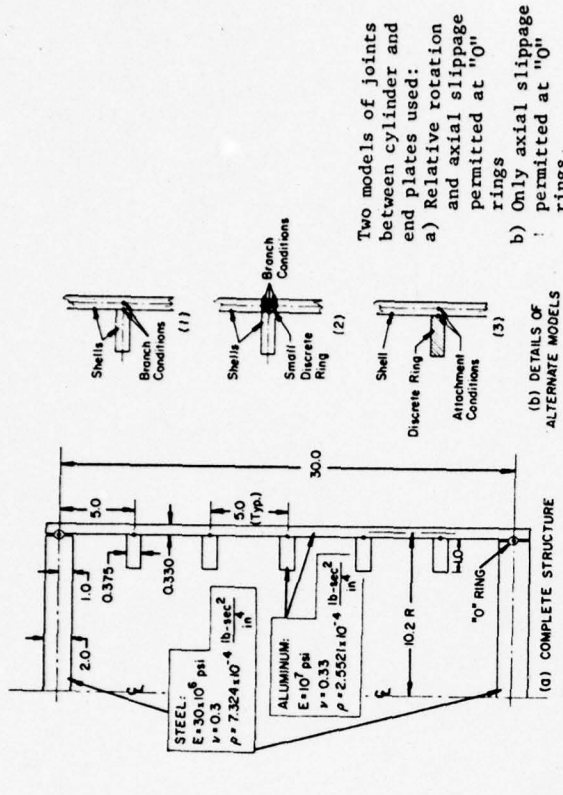

Fig. 21 (a) Geometry of ring stiffened cylinder tested by Hayek and Pallett. (b) Various models of the rings

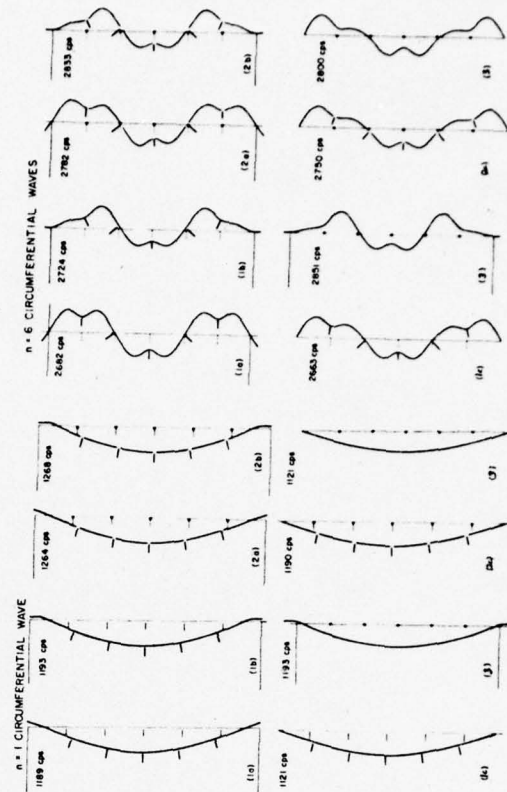

Fig. 22 Vibration modes corresponding to one and six circumferential waves

Modeling Discrete Rings When Local Buckling Between Rings is Possible

Some BOSOR4 users have been concerned that occasionally buckling loads predicted for externally pressurized ring stiffened cylinders are unexpectedly high. In these cases the predicted buckling modes are usually local (deflections between rings with rings at nodes in the buckling pattern). Aside from the question of initial imperfections, there is another reason that too high buckling loads may be calculated: in the actual structure the webs of ring stiffeners probably deform considerably in the local buckling mode. This deformation can be accounted for if the webs of the rings are treated as flexible shell branches as shown in Fig. 24. The user should include in his parameter studies such a model, at least for a section of ring stiffened shell spanning two adjacent rings. It is rarely necessary to include the outstanding flanges as shells, since they can remain discrete rings.

Figure 25 shows a comparison of predicted buckling pressures of a cylinder with two models of a ring, one in which its cross section cannot deform (labeled "Ring") and the other in which it can (labeled "Branched Shell"). Reference [13] has more discussion on this and other points about modeling discrete rings.

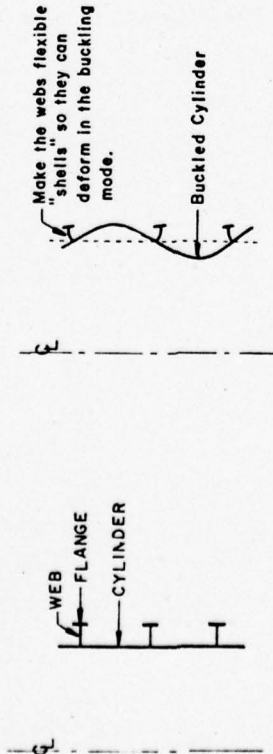

Fig. 24 Cylinder with ring webs modeled as flexible shell branches

When Stiffeners Can Be "Smearred"

If there exists a regular pattern of reasonably closely spaced stiffeners, their contribution to the wall stiffness of the shell or plate might be modeled by an averaging of their extensional and bending rigidities over arc lengths equal to the local spacings between them. Thus, the actual wall is treated as if it were orthotropic. In BOSOR4 this "smearing" process accounts for the fact that the neutral axes of the stiffeners do not in general lie in the plane of the reference surface of the shell wall. Predictions of buckling loads and vibration frequencies of stiffened cylinders have been found to be very sensitive to this eccentricity effect. A general rule of thumb for deciding to smear out the stiffeners or

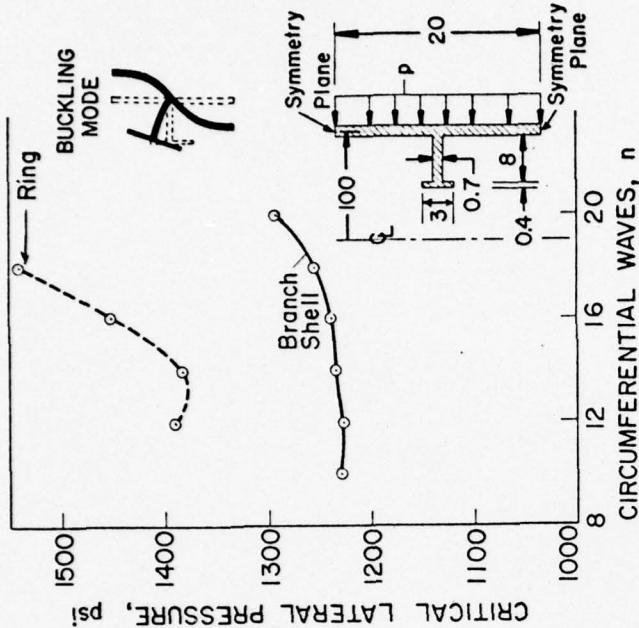

Fig. 25 Comparison of local buckling pressures of a ring stiffened cylinder for two models of the ring

to treat them as discrete is that for smearing there should be about 2 to 3 stiffeners per half wavelength of the deformation pattern. It may be appropriate to smear out stiffeners in a buckling or vibration analysis but, because of local stress concentrations caused by the stiffeners, not in a stress analysis. The stiffeners can be smeared as an analytical device to suppress local buckling and vibration modes. In order to handle problems involving smeared stiffeners, a computerized analysis must include coupling between bending and extensional energy.

Modeling Prismatic Shell Structures

An interesting and not immediately obvious use of BOSOR4 is for buckling and vibration analysis of prismatic shell structures, in particular composite branched panels. This technique of using a shell of revolution program for the treatment of structures that

are not axisymmetric is discussed in detail in Ref [2]. Figure 26 shows various types of prismatic shell structures that can be handled by BOSOR4. Examples involving stress and buckling of oval cylinders, cylinders with nonuniform loads, and corrugated and beaded panels are given in Ref. [2], as well as a study of vibration of a stringer stiffened shell in which the stringers are treated as discrete. In the analysis of buckling of nonuniformly loaded cylinders, the nonsymmetry of the prestress can be accounted for in the stability analysis. In BOSOR4 the capability described in Ref. [2] is extended to branched prismatic shell structures.

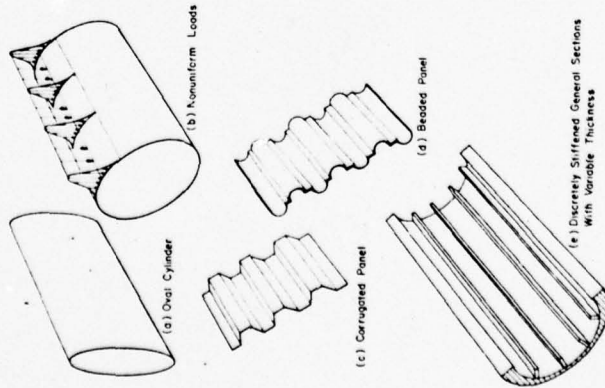
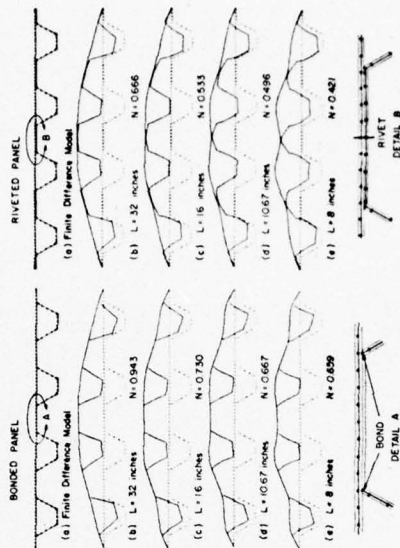

Fig. 26 Some prismatic shell structures that can be analyzed with use of BOSOR4

Example of Analysis of Prismatic "Shell" Structure

Figure 27 shows two types of semisandwich corrugated construction, bonded and riveted. The panels are treated as giant annuli with mean radius of 2,750 in. and outer radius minus inner radius equal to about 7.4 in. Both panels are assumed to carry an axial compressive stress (panels loaded normal to plane of figure) that is constant along the axis of the panel and over all of the little segments shown at the top of Fig. 27. In the model on the left-hand side of the figure the troughs of the corrugated sheet and the flat skin are assumed to be united by a perfect bond of zero thickness. The thickness of the panel in these areas is equal to the sum of the thickness of the flat sheet and the corrugated sheet. In the riveted panel the displacements and rotations of the corrugated sheet are constrained to be equal to those of the flat skin only at the midlengths of the troughs, thus simulating a rivet of zero diameter in the plane of the paper and continuous in the direction normal to the plane of the paper. The computer generated plots show the undeformed and deformed panels for buckling modes with various wave lengths L in the direction normal to the plane of the paper. The riveted panel is weaker in axial compression because the rivets permit more local distortion of the cross section than does the continuous bonding. The modes shown are more or less general instability modes. One can calculate buckling loads for much shorter L , such as $L = 1.0$ in., in order to determine the effect of fastening on crippling loads.



L = Axial Half-Wavelength of Buckling Mode.

N = $\frac{1}{L}$ (Critical Axial Load)

$N = \frac{1}{L}$ (Critical Axial Load With Local Distortion of Wall Cross-Section Not Allowed)

Fig. 27 Buckling modes and loads for axially compressed bonded and riveted corrugated panels

Modeling Concentrated Loads on Shells

The analyst may be interested in several types of concentrated loads which arise in various ways. If the shell structure is to be subjected to concentrated loads in the ordinary course of its service, such as a tank supported on struts or a rocket stage with discrete payload attach points, it is usually provided that the concentrated loads be applied to reinforced areas such as circumferential rings or longitudinal stringers through which these loads are smoothly diffused into the shell. Therefore, deflections are small, and a linear analysis is generally suitable. If, however, the analyst wants to find out what happens if the shell is accidentally poked somewhere, the concentrated load may be applied to an unreinforced area, and the shell may experience large deflections. Prediction of the effect of these accidental loads may therefore require nonlinear analysis. The point-loaded spherical cap, for which a load-deflection curve is shown in Fig. 15, is an example. In BOSOR4 a concentrated load applied such that nonsymmetric displacements occur is modeled as a line load with a triangular distribution around the circumference. Figure 28 shows an example. Each load is simulated by the area within the triangular "pulse" multiplied by some factor provided by the user as an input datum.

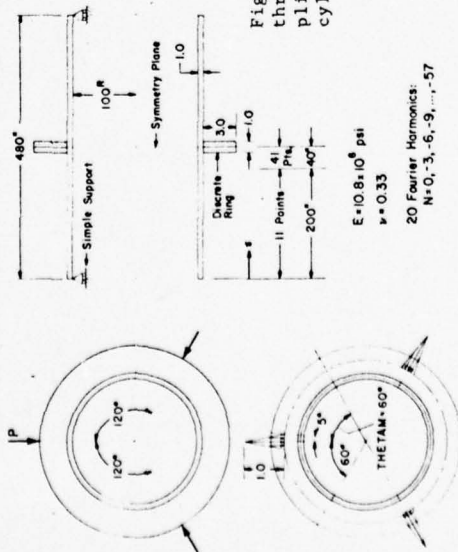
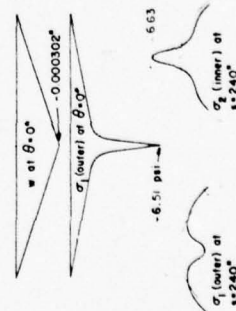

Fig. 28 Cylinder with three point loads applied to ring at cylinder midlength



Constraint Condition Problems to Be Wary Of

There are certain commonly occurring situations in which the program user should take great care with regard to constraint conditions. These involve rigid body behavior, symmetric vs. antisymmetric behavior at planes of symmetry in the structure, singularity conditions at poles of shells of revolution, discontinuities between various branches and segments of a complex shell structure, and unexpected sensitivity of predicted behavior to changes in boundary conditions.

Rigid body displacement. Rigid body displacement of an analytical model of a structure should not be permitted in static stress and buckling problems. In such problems the shell must be held in such a way that no constraints are introduced which are not actually present in the real structure. The proper application of rigid body constraint conditions requires special care in the case of non-symmetrically loaded shells of revolution. These conditions apply only if the displacements are axisymmetric, or if the displacements vary with one circumferential wave around the circumference and must be released for higher displacement harmonics.

Symmetry planes. Many problems are best analyzed by a modeling of a small portion of the actual structure bounded by symmetry planes. In bifurcation buckling and modal vibration problems important modes may be antisymmetrical at one or more of the symmetry planes. This occurrence implies that symmetry boundary conditions should be applied in the prestress analysis and antisymmetry conditions at one or more of the symmetry planes in the eigenvalue analysis for bifurcation buckling or modal vibration. Unless the program user is certain about the behavior at a symmetry plane, he must make multiple runs on the computer, testing for both symmetrical and antisymmetrical behavior at each symmetry plane.

Singularity conditions at a pole. The problem of singularity conditions arises only in the case of shells of revolution or flat circular plates. As with rigid body modes, special conditions must be applied for axisymmetric ($n = 0$) displacements or for displacement modes with one circumferential wave ($n = 1$). If $n \geq 2$ the pole condition acts as a clamped boundary.

Constraint conditions for discontinuous domains. Practical shell structures are very frequently assembled so that the combined reference surfaces of the various branches and segments of the analytical model form a discontinuous domain. The BOSOR4 user should be aware that the constraint conditions governing the compatibility relations between adjacent surfaces imply that a rigid connection exists across the discontinuity. Thus the analytical model is stiffer than the actual structure. Buckling loads and vibration frequencies will be overestimated. It is likely that local discontinuity stresses will also be overestimated.

Unexpected sensitivity of predicted behavior to changes in boundary conditions. Frequently, complicated shell structures are designed and manufactured by more than one company or by more than one organization within a company. Each company or organization is responsible for only one particular segment of the entire structure, and often the properties of the adjoining segments are known only approximately if at all. Therefore some conditions must be assumed at the boundaries of each segment during the design phase of that segment. The purpose of this section is to warn the analyst that predictions of stress, buckling, and vibration of shells may be very sensitive to boundary conditions even though intuition dictates otherwise. Engineers interested in designing a particular segment of a larger structure should make every effort to determine as accurately as possible the actual boundary conditions at the ends of "their" segment. Portions of the adjoining segments should be included in the model, possibly with a cruder mesh. If little is known about the adjoining structures, sensitivity studies should be performed in which both upper and lower bounds on the degree of boundary constraint are assumed.

INPUT DATA

A preprocessor has been written for BOSOR4 by means of which the input data can be prepared in free format [14]. Figure 29 shows a sample BOSOR4 data deck.

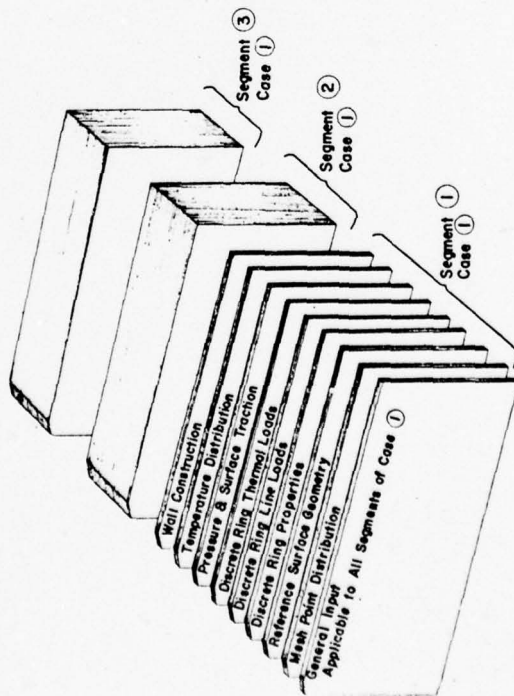

Fig. 29 Sample BOSOR4 data deck

ACKNOWLEDGEMENTS

The author is indebted to Frank Brogan, Tom Peterson, Chet Dyche, Bo Almroth, Bill Loden, and Rod Kure, who wrote some of the subroutines used in the BOSOR4 program. Particular appreciation is expressed for the many fruitful discussions with Frank Brogan and Bo Almroth concerning the numerical aspects of the analysis, and with Jørgen Skogh about ways in which to make the BOSOR4 program easy to use. The author is thankful also for Frank Brogan's assistance in the conversion of BOSOR4 for operation on the CDC 6600 and Tom Peterson's, Pete Smolenski's, and Bob Mitchell's assistance in the conversion for operation on the IBM 370/165.

The development of BOSOR4 was sponsored by the Department of Structural Mechanics of the Naval Ship Research and Development Center under Naval Ship Systems Command, Operation and Maintenance Navy Fund, Contract N00014-71-C-0002. Rembert Jones and Joan Roderick were technical monitors. The work involved in converting BOSOR4 for operation on the CDC 6600 was sponsored by the NASA Langley Research Center, Contract NAS1-10929, with Paul Cooper as technical monitor.

Some of the numerical studies were performed under the Lockheed Missiles & Space Company's Independent Research Program. The support of ONR under Contract N00014-76-C-0692, with Nicholas Perrone and Kenneth Saczalski as technical monitors, is gratefully acknowledged.

The following figures have been reprinted by permission:

Figs. 1 - 3 from D. Bushnell, B. O. Almroth, and F. Brogan, "Finite-Difference Energy Method for Nonlinear Shell Analysis," *Computers & Structures*, Vol. 1, 1971, pp. 361-387, © 1971.

Figs. 7, 8, 11, 12, 14, 19, 20, 28, 29 and Table 2 from D. Bushnell, "Stress, Stability and Vibration of Complex, Branched Shells of Revolution," *Computers & Structures*, Vol. 4, 1974, pp. 399-435, © 1974.

Figs. 9, 10 from D. Bushnell, "Finite-Difference Energy Models versus Finite-Element Models: Two Variational Approaches in One Computer Program," *Numerical and Computer Methods in Structural Mechanics*, pp. 291-336, © 1973, Academic Press, New York.

Fig. 13 from D. Bushnell, "Nonlinear Analysis for Axisymmetric Elastic Stresses in Ring-Stiffened, Segmented Shells of Revolution," *AIAA/ASME 10th Structures, Structural Dynamics and Materials Conference*, pp. 104-113, © 1969, ASNE.

Fig. 16, 17 from D. Bushnell, "Crippling and Buckling of Corrugated Ring-Stiffened Cylinders," *AIAA Journal of Spacecraft and Rockets*, Vol. 9, No. 5, 1972, pp. 357-363, © 1972, AIAA.

Fig. 18 from D. Bushnell and S. Smith, "Stress and Buckling of Nonuniformly Heated Cylindrical and Conical Shells," *AIAA Journal*, Vol. 9, No. 12, Dec. 1971, pp. 2314-2321, © 1971, AIAA.

Figs. 21 through 23 and Table 3 from D. Bushnell, "Thin Shells," *Structural Mechanics Computer Programs*, University Press of Virginia, pp. 277-358 © 1972.

Fig. 26 from D. Bushnell, "Stress, Buckling, and Vibration of Prismatic Shells," *AIAA Journal*, Vol. 9, No. 10, Oct. 1971, pp. 2003-2013, © 1971, AIAA.

Fig. 27 from D. Bushnell, "Evaluation of Various Analytical Models for Buckling and Vibration of Stiffened Shells," AIAA Journal, Vol. 11, No. 9, 1973, pp. 1283-1291 © 1973, AIAA.

REFERENCES

- 1 Bushnell, D., "Stress, Stability, and Vibration of Complex Branched Shells of Revolution, Analysis and User's Manual for BOSOR4," LMSC-D243605, Lockheed Missiles & Space Co., Inc., Sunnyvale, Ca., March 1972.
- Also NASA CR-2116, Oct. 1972.
- 2 Bushnell, D., "Stress, Buckling, and Vibration of Prismatic Shells," AIAA Journal, Vol. 9, No. 10, Oct. 1971, pp. 2004-13.
- 3 Bushnell, D., Almroth, B. O., and Brogan, F. A., "Finite-Difference Energy Method for Nonlinear Shell Analysis," Journal for Computers & Structures, Vol. 1, 1971, pp. 361-87.
- 4 Bushnell, D., "Analysis of Ring-Stiffened Shells of Revolution under Combined Thermal and Mechanical Loading," AIAA Journal, Vol. 9, No. 3, March 1971, pp. 401-10.
- 5 Bushnell, D., "Finite-Difference Energy Models Versus Finite Element Models: Two Variational Approaches in One Computer Program," Numerical and Computer Methods in Structural Mechanics, edited by Fenves, S. J., Perrone, N., Robinson, A. R., and Schnobrich, W. C., Academic Press, Inc., New York and London, 1973, pp. 291-336.
- 6 Bushnell, D., "Analysis of Buckling and Vibration of Ring-Stiffened, Segmented Shells of Revolution," International Journal of Solids Structures, Vol. 6, 1970, pp. 157-181.
- 7 Bushnell, D., "Thin Shells," Structural Mechanics Computer Programs, edited by Pilkey, W., Saczalski, K. and Schaeffer, H., University Press of Virginia, Charlottesville, 1974, pp. 277-358.
- 8 Penning, F. A. and Thurston, G. A., "The Stability of Shallow Spherical Shells Under Concentrated Load," MASA CR-265, July 1965.
- 9 Holmes, A., "Measurement of Thermal Stresses in Ring-Stiffened Cylinders," LMSC-YL-69-66-1, Lockheed Missiles & Space Co., Palo Alto, Ca., Dec. 1966.
- 10 Bushnell, D. and Smith, S., "Stress and Buckling of Nonuniformly Heated Cylindrical and Conical Shells," AIAA Journal, Vol. 9, No. 12, 1971, pp. 2314-2321.
- 11 Hayek, S. and Pallett, D. S., "Theoretical and Experimental Studies of the Vibration of Fluid Loaded Cylindrical Shells," Symposium on Application of Experimental and Theoretical Structural Dynamics, Southampton University, England, April 1972.
- 12 Harari, A. and Baron, M. L., "Analysis for the Dynamic Response of Stiffened Shells," ASME Paper No. 73-APM-FFF, to appear J. Appl. Mech.
- 13 Bushnell, D., "Evaluation of Various Analytical Models for Buckling and Vibration of Stiffened Shells," AIAA Journal, Vol. 11, No. 9, 1973, pp. 1283-1291.
- 14 BOSOR4 PREPROCESSOR written by and available from SKD Enterprise, 9138 Barbary Lane, Hickory Hills, Illinois 60457.

APPENDIX A

BOSOR4 INPUT DATA

This appendix is organized in the following way: First there is a page which gives some useful hints on how to set up a case; then there are two pages which define certain input data that depend on what type of analysis is to be performed; these two pages are followed by seven pages describing constraint and juncture conditions; then come three pages on load and temperature multipliers and ranges. All of these pages just described correspond to the initial cards in the input deck labeled "General Input--Applicable to All Segments of Case 1" in Fig. 29.

The remaining input data for a case are defined on pages 61 - 98. These data are required for each segment of the structure. The data input section is subdivided into the following subsections:

1. Mesh Point Distribution
2. Reference Surface Geometry
3. Discrete Ring Properties
4. Discrete Ring Line Loads
5. Discrete Ring Thermal Loads
6. Pressure and Surface Traction
7. Temperature Distribution
8. Prestress Input Data for the Option INDI = 4, IPRE = 0
9. Wall Construction

The input data specifications are written in a style very similar to FORTRAN. It is therefore assumed that the user is familiar with this language.

Following the input data definition are sample input decks corresponding to each type of analysis. (INDIC = 1, -1, 0, 2, 3, 4, -2). The user is urged to consult these cases since they will clarify many of the input specifications which may at first seem rather arcane.

A section entitled "Possible Pitfalls and Recommended Solutions" then follows. The user should read this section even if he has not yet encountered a problem. There are some suggestions given there that may help the user decide how to set up an appropriate model.

Finally, there is a brief description of BOSOR4 output, including sample list and plot output corresponding to the first sample case.

Some Useful Hints on How to Set Up a Case

1. Decide how many segments the shell should be divided into. Should ring stiffeners be treated as shell segments or discrete rings? It is often advisable to handle ring webs as flexible shell segments rather than as discrete ring segments

2. Decide how to number the segments. Think of the axis of revolution as being vertical and the shell meridian that you are working with as being to the right-hand side of this axis. Try to "travel" along the structure in a generally "northeasterly" direction whenever possible

3. Lay out the entire structure on graph paper

4. Use the middle surface as a reference surface whenever it is reasonably easy to do so. Convergence with increasing mesh point density is fastest that way

5. Decide on mesh point distributions in each segment. Show the nodal points on the graph paper. Nodes should be located at discrete ring stations and at branch stations. Nodes should be equally spaced for at least one interval on either side of these rings and branch stations

6. Plan to use at least 5 nodes per half-wavelength of the probable buckling modes. Concentrate nodes near stress concentrations

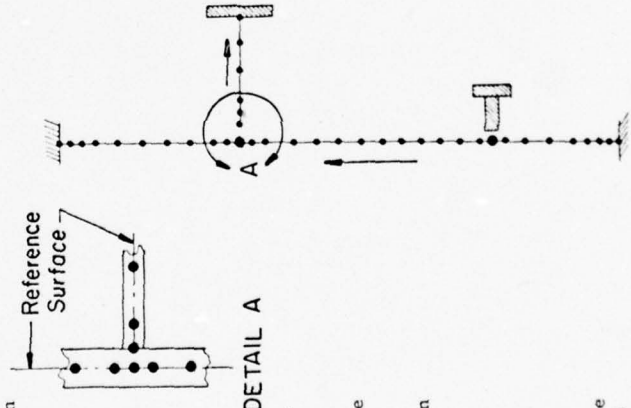
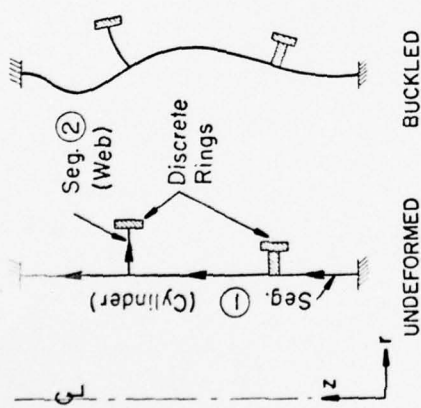

INPUT DATA FOR THE BOSOR4 USER'S MANUAL

Initial Input For Various Types of Analysis (INDIC = 0, -2, -1, 1, 2)

INDIC = 0 (nonlinear Axisymmetric stress analysis) INDIC = -2, -1, 1, 2 (Bifurcation buckling, modal vibration)

● TITLE
 ● 0, NPRT, NLAST, ISTRS, 0
 ● NSEG, NCOND, IBOUND, IRIGID
 ● 0, 0, 0
 ● 0, 0, 0
 ● 0, 0, 0, 0, 0
 ● 0, 0, 0
 ● 0
 ● 0, 0, 0, 0.

Definitions of Input Variables*

TITLE = title of case (72 characters or less).

INDIC = analysis type parameter:

0 = nonlinear elastic axisymmetric stress analysis,
 -2 = stability determinant calculated for increasing load,
 -1 = bifurcation buckling with nonlinear prebuckling analysis,
 1 = bifurcation buckling with "linear" prebuckling analysis
 (see section on stability)

2 = modal vibration with axisymmetric nonlinear prestress.
 See the section on scope of BOSOR4 for more details on INDIC.

NPRT = printout options: 1 = minimum, 2 = medium, 3 = max. Use 2.

NLAST = plot option: 0 = yes plots, -1 = no plots.

ISTRS = control for output: 0 = resultants; 1 = stresses. (use 1 with monocoque shells only.)

NSEG = number of shell segments. Must be less than 25.

NCOND = number of points at which constraint conditions are to be imposed, including junctures between segments. Must be less than 50.

IBOUND = control integer for constraint conditions:

0 means bifurcation buckling and modal vibration constraint conditions are the same as those for axisymmetric prestress analysis,

1 means that buckling and vibration constraint conditions are different from those for axisymmetric prestress analysis.

IRIGID = control integer for rigid body displacements:

0 means no extra rigid body constraints are necessary,

1 means that extra rigid body constraints are necessary.
 By "extra" is meant in addition to regular constraint conditions (still to be specified).

NOB, NMINB, NMAXB, INCRB, NVEC = initial, minimum, maximum circumferential wave numbers to be used in the buckling or vibration analysis; increment in the wave number; number of eigenvalues to calculate for each wave number.

* Variables beginning with I, J, K, L, M, N are fixed point. The rest are floating point. The symbol ● means "read".

Initial Input For Various Types of Analysis (Contd) (INDIC = 3,4)

INDIC = 3 (Linear nonsymmetric stress analysis)

- TITLE
- 3, NPRT, NLAST, ISTRRES, 0
- NSEG, NCOND, 0, IRIGID
- NSTART, NFIN, INCR
- 0, 0, 0, 0
- NDIST, NCIRC, NTHETA
- ITHETA(I), I = 1, NCIRC
- THETA(I), I = 1, NDIST
- THETAM, 0, 0.

Definitions of Input Variables*

TITLE = title of case (72 characters or less).
 INDIC = analysis type indicator: 3 = stress, 4 = stress and buckling.
 NPRT = printout options: 1 = minimum, 2 = medium, 3 = max; use 2.
 NLAST = plot option: 0 = yes plots, -1 = no plots.
 ISTRRES = 0 = stress resultants; 1 = stresses (1 with monocoque only).
 IPRE = 0 = prestress from input data; 1 = prestress calculated.
 NSEG = number of shell segments; must be less than 25.
 NCOND = number of points at which constraints are applied, including junctions between segments.
 IBOUND = control for constraint conditions; see previous page.
 IRIGID = control for rigid body displacements.
 NSTART, NFIN, INCR = starting, ending, and increment in the number of circumferential waves to be used in the nonlinear nonsymmetric stress analysis. May be negative. These are the Fourier harmonics of the linear stress analysis.
 NOB, NMINB, NMAXB, INCRB, NVECB = initial, minimum, maximum circumferential wave numbers to be used in the buckling analysis; increment in the wave number; number of eigenvalues to calculate for each wave, n.
 NDIST = number of circumferential stations for which meridional distributions will be printed and/or plotted (less than 20).
 Note: NDIST*IALL*9 < 2700, where IALL = total no. of nodes.
 NCIRC = number of meridional stations for which circumferential distributions will be printed and/or plotted (less than 20).
 NTHETA = number of points in the output for circumferential distributions; must be less than 100. Note: NCIRC*NTHETA*9 < 2700.
 ITHETA = meridional stations for circumferential distributions: e.g., 1011 means segment 1, mesh point 11.
 THETA = circumferential stations in degrees for which meridional distributions will be printed and plotted. Must be less than or equal to THETAM.
 THETAM = circumferential distributions printed and plotted for $0 \leq \theta \leq$ THETAM (deg.); Loads expanded in Fourier series in the interval $-\text{THETAM} \leq \theta \leq \text{THETAM}$. THETAM is usually equal to 180.0.
 THETAS = meridional distribution of prebuckling stress at $\theta = \text{THETAS}$ degrees is used in the stability analysis with options INDIC = 4 and IPRE = 1.

* Variables beginning with I, J, K, L, M, N are fixed point. The rest are floating point. The symbol ● means "read".

Do 3 I = 1, NCOND

- IS1, IP1, IS2, IP2, IU*, IV, IW*, IX, DX, DI, D2
- 3 Continue

Definitions of Input Variables

NCOND = number of points at which constraints are imposed, including junctions between segments. NCOND = 4 in the example below. Four kinds of constraint conditions exist in BOSOR4:

1. constraints to ground (e.g., boundary conditions)
2. juncture compatibility conditions,
3. regularity conditions at poles (where the radius $r = 0$).
4. constraints to prevent rigid body displacements.

IS1, IP1, IS2, IP2 = segment and node point numbers involved in a constraint condition. For example, a juncture compatibility condition might contain IS1, IP1, IS2, IP2 = 1, 25, 2, 5 meaning, "segment 1, point 25 is connected to segment 2, point 5". A constraint to ground might contain IS1, IP1, IS2, IP2 = 1, 25, 1, 25

meaning that segment 1, point 25 is in some way (yet to be specified) connected to ground. Regularity conditions and constraints to prevent rigid body displacements are expressed in the same way as constraints to ground. See the following examples for further clarification.

IU*, IV, IW*, IX = indicators for no or yes constraint of global displacement components u^* , v^* , w^* , x^* , respectively. 0 means no constraint; 1 means yes there is a constraint of the corresponding displacement component. For example, a juncture compatibility condition usually contains IS1, IP1, IS2, IP2, IU*, IV, IW*, IX = 1, 25, 2, 5, 1, 1, 1, 1 which means that all the displacement components and the meridional rotation of segment 2, point 5 are "slaved" to those of segment 1, point 25. A constraint to ground reads: IS1, IP1, IS2, IP2, IU*, IV, IW*, IX = 1, 25, 1, 25, 1, 1, 1, 0 which means that u^* , v^* , w^* are zero at segment 1, point 25 and the meridional rotation is free there (hinge).

DI, D2 = radial, axial components of discontinuity between segments, or offset of support point from nodal point involved in a constraint to ground. See Fig. A1 for positive sense of DI, D2.

For the figure here, we might have:

- 1,1,1,1,1,1,1,0,0,0,
 - 1,7,2,1,1,1,1,0,0,0,
 - 2,5,3,1,1,1,1,1,1,4
 - 3,9,3,9,0,0,0,0,0,0.
- (A pole is treated just as done in the fourth line. BOSOR4 automatically applies the correct IU*, IV, IW*, IX, which depend on circ. n.)

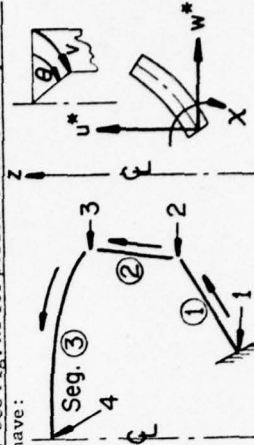

Constraint Conditions (Continued) More on D1 and D2

The figure below shows a meridional discontinuity (a) and boundary support eccentricity (b). In the figure (a):

D1 and D2 are positive as shown if $J \geq 0$

D1 and D2 are negative as shown if $J < 0$

This sign convention thus depends only on the relative numbering of the segments involved in the junction. It does not depend on the direction of increasing arc length, nor on whether the user specifies "Segment ISEG is connected to segment ISEG+J" or "Segment ISEG+J is connected to ISEG." In Fig. A1(b) the "discontinuities" D1 and D2 are positive as shown, independent of the direction of increasing arc length.

In general, it is recommended that users construct models such that there are no axial discontinuities ($D2 = 0$) between segments. Axial discontinuities tend to lead to gross overestimates of the stiffness of a structure, and hence to overestimates of buckling loads. See the article "Evaluation of various analytical models for buckling and vibration of stiffened shells" *AIAA Journal*, Vol. 11, No. 9, 1973, pp. 1283-1291, for examples.

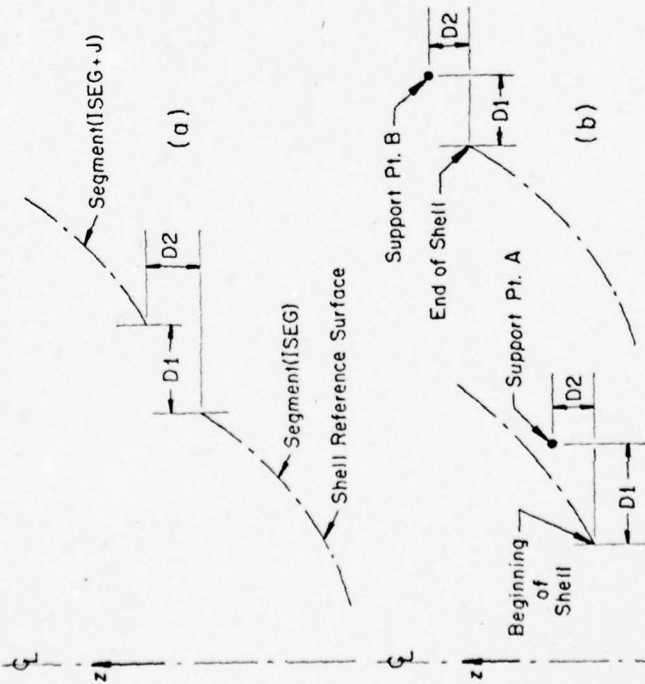

Meridional discontinuity components and support offsets are positive in the above illustrations.

Fig. A1 Sign convention for discontinuities

Restriction on Frequency of Constraint Points

Constraint conditions can be applied at points in the interior of segments as well as at the boundaries. However, points within a given segment at which constraint conditions are applied must be spaced at intervals of at least three nodes, as shown below:

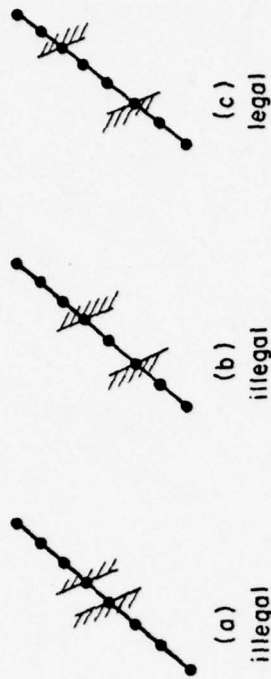

Restriction on Branching Conditions

If several segments are joined together, as shown below, the correct way to express the constraint condition input is to connect all higher numbered segments to the lowest numbered segment involved in the juncture. Sample input for IS1, IP1, IS2, IP2, etc. is given below:

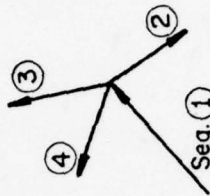

Sample input (IS1, IP1, IS2, IP2, etc.) corresponding to the figure at left:

1, 25, 2, 1, 1, 1, 1, 1, 0., 0.
1, 25, 3, 1, 1, 1, 1, 1, 0., 0.
1, 25, 4, 1, 1, 1, 1, 1, 1, 0., 0.

If the end of Segment J is connected to any previous point, or to ground (b.c.), then the beginning of Segment J+1 cannot be connected to the end of Segment J.

Rigid Body Constraints

There are six rigid body modes, three translational and three rotational. These modes are illustrated below.

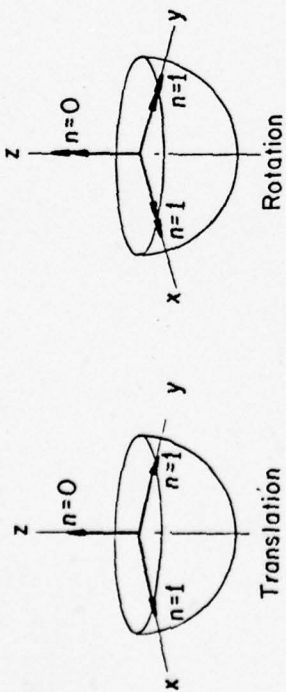

All of these rigid body motions can be prevented by choosing a meridional station at which to restrain the axial displacement u^* and the circumferential displacement v . The figures below show why:

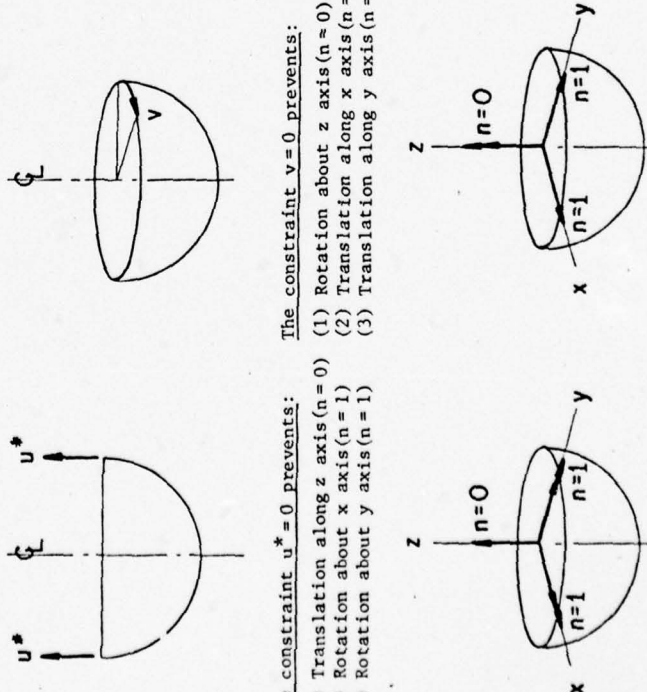

- The constraint $u^* = 0$ prevents:
- (1) Translation along z axis ($n = 0$)
 - (2) Rotation about x axis ($n = 1$)
 - (3) Rotation about y axis ($n = 1$)
- The constraint $v = 0$ prevents:
- (1) Rotation about z axis ($n = 0$)
 - (2) Translation along x axis ($n = 1$)
 - (3) Translation along y axis ($n = 1$)

Example:

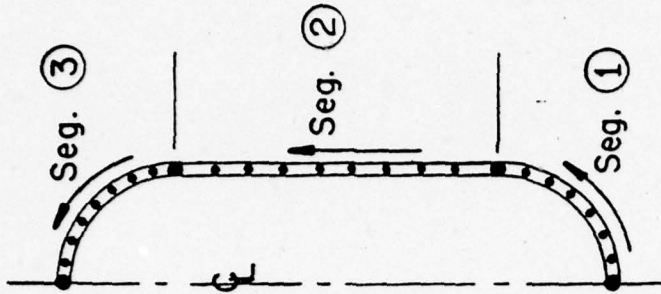

Example of constraint conditions corresponding to the figure above. Note that an extra constraint point has been provided (NCOND = 5 rather than 4) in order to have a station at which to apply the rigid body mode constraints for $n = 0$ and $n = 1$ circumferential waves.

Constraint condition input (NCOND = 5):

1, 1, 1, 0, 0, 0, 0, 0, 0, 0.	(pole condition)
1, 8, 2, 1, 1, 1, 1, 1, 0, 0.	(juncture condition)
2, 1, 2, 1, 0, 0, 0, 0, 0, 0.	(extra condition)
3, 9, 3, 1, 1, 1, 1, 1, 0, 0.	(juncture condition)
	(pole condition)
2, 1, 2, 1, 1, 1, 1, 0, 0	(rigid body condition)
2, 1, 2, 1, 1, 1, 1, 0, 0	(rigid body condition)

NOTE: If a constraint to ground is applied at a juncture between two segments, it must be applied at the first point of the higher-numbered segment.

Continuation of Initial Input for Various Types of Analysis
INDIC = -2, -1, 0, 1, 2, 3, and 4

INDIC = -2 and 0 (bifurcation buckling INDIC = -1 and 1 (nonlinear and nonlinear axisymmetric linear bifurcation buckling) stress analysis)

● P, DP, TEMP, DTEMP
● FSTART, FMAX, DF

● P, DP, TEMP, DTEMP
● 0., 0., 0.

INDIC = 2 (vibration analysis)

INDIC = 3 and 4 (linear nonaxisymmetric stress analysis and bifurcation buckling with non-axisymmetric prestress)

● P, 0., TEMP, 0.
● 0., 0., 0.

Definitions of Input Variables and Explanation

P = pressure or surface traction multiplier. Actual pressure $p(s)$ is given by $p(s) = P * f(s)$, where $f(s)$ is a meridional distribution read in later for each shell segment. P is associated with fixed or initial loads. See below for more explanation and examples.

DP = pressure or surface traction increment multiplier. Actual pressure increment is given by $dp(s) = DP * f(s)$. With INDIC = 0 or -2 the first pressure treated is $P * f(s)$, the second is $(P + DP) * f(s)$ and so on up to FMAX * $f(s)$. With INDIC = -1 or 1, DP is an eigenvalue parameter. See below for more explanation and examples.

TEMP = temperature rise multiplier. The actual temperature rise $T(s, z)$ is given by $T(s, z) = TEMP * g(s) * h(z)$, where $g(s)$ is a meridional distribution and $h(z)$ is a thickness distributed read in later for each shell segment. TEMP is associated with fixed or initial loads. See below for more explanation.

DTEMP = temperature rise increment multiplier. Actual temperature rise increment is given by $dT(s, z) = DTEMP * g(s) * h(z)$. See definition of DP for more details.

FSTART, FMAX, DF = load range delimiters, increment. These may represent pressure, temperature, or discrete ring thermal or mechanical line loads. These quantities serve only to establish the range of loading, and are not used as actual loads in BOSOR4. They simply tell the computer when to terminate the case. That is their only function in BOSOR4.

More Detailed Explanation of Fixed or Initial (P, TEMP, V) Loads and Incremental or Eigenvalue (DP, DTEMP, DV) Loads: An Example

The user can introduce into BOSOR4 pressure, surface tractions, temperature distributions over the shell, and line mechanical and thermal loads on the discrete rings. Each of these types of loads have two categories: 1. fixed or initial, and 2. incremental or eigenvalue. The appropriate use of these two categories of loads for various kinds of analysis (INDIC) is best communicated by an example. Figure A2a

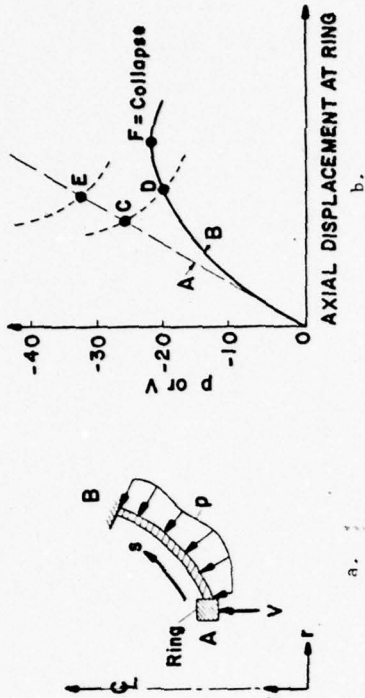

Fig. A2 Spherical cap with combined axial load and external pressure shows a clamped spherical segment, subjected to a combination of axial compression V and normal pressure, P. Figure A2b shows typical load-deflection curves from linear (A) and nonlinear (B) theory. We wish to:

1. Calculate the nonlinear axisymmetric behavior (B) (INDIC = 0)
2. Calculate the bifurcation buckling load (D) (INDIC = -1)
3. Calculate the bifurcation buckling loads (C, E) (INDIC = 1)
4. Calculate vibration frequencies for given V_0 and P_0 (INDIC = 2) (INDIC = -2)
5. Calculate the stability determinant as a function of load (INDIC = -2)

Let us suppose for the moment that P is known and fixed at $P_0 = -10.0$ (uniform) and that we wish to investigate the above behavior with V unknown. All loads are assumed to be axisymmetric in this example. The scale 0 to 40 in the above sketch refers then to V, and the characteristics of the curves A and B and location of the points C and D depend on the specified pressure P_0 as well as on the geometry, boundary conditions, and material properties. The table below shows appropriate example values of the load input data for the five types of analysis just listed. Analyses with INDIC = -2, -1, and 1 involve the calculation of bifurcation buckling eigenvalues. With INDIC = -2 and -1 both V and DV are changed during the case, and the buckling load V_{crit} is printed with the mode shape at the end of the run. With INDIC = 1 the eigenvalues and eigenvectors are printed, but the user must obtain the corresponding buckling load V_{crit} from the equation:

$$V_{crit} = V + (\text{eigenvalue}) * DV$$

Table A1 Appropriate Sample Values of P, DP, V, DV, FSTART, FMAX, and DF for various values of INDIC

INDIC	P	DP	V	DV	FSTART	FMAX	DF
-2	-10.0	0.	0.	-5.0	0.	-40.0	-5.0
-1	-10.0	0.	-15.0	-1.0	not applicable		
0	-10.0	0.	0.	-5.0	0.	-40.0	-5.0
1	-10.0	0.	0.	-1.0	not applicable		
2	-10.0	0.	$V_0 < F$	0.	not applicable		

More information on the Load Range Delimiters, FSTART, FMAX, DF

The load range delimiters FSTART and FMAX and the increment DF serve only to establish the range of loading and these quantities are not used as actual loads in BOSOR4. They simply "tell" the computer when to terminate the case. That is their only function in BOSOR4. Some examples follow:

Example 1: shell loaded by "fixed" pressure, "variable-in-time" axial load:

P = 10 psi DP = 0.0 V(1) = -1000 lb/in DV(1) = -200 lb/in
FSTART = -1000 FMAX = -5000 DF = -200

Example 2: shell loaded by "variable-in-time" pressure, "fixed" axial load:

P = 20 psi DP = 5 psi V(1) = -3000 lb/in DV(1) = 0.0 lb/in
FSTART = 20 FMAX = 100 DF = 5

Example 3: shell loaded by "variable-in-time" pressure and "variable-in-time" axial load:

P = 20 DP = 5 psi V(1) = -1000 lb/in DV(1) = -200 lb/in
FSTART = 20, FMAX = 100, DF = 5 or FSTART = -1000, FMAX = -5000,
DF = -200

From the above three examples it is seen that:

1. The load range delimiters represent the range of one of the "variable-in-time" loads.
2. The load range delimiters have the same algebraic signs as the corresponding "variable-in-time" load.
3. In cases involving more than one "variable-in-time" load, the load range delimiters may represent the range of any one of the "variable-in-time" loads.

Input Data for Each Shell Segment (All Types of Analysis)

The remaining input is read in for each shell segment. The input manual is constructed as a sort of program, with labeled transfer points which help tell the user what data to provide next. A summary of the entire input for each segment is given on this page, and details for each kind of input are given on the following pages.

Summary of Input for Each Segment

Do 5000 ISEG = 1, NSEG

- 12 Read in number and distribution of nodal points.
- 15 Read in shell geometry parameters and imperfection shape.
- 20 Read in location of reference surface relative to left-most surface of the shell wall material.
- 25 Read in discrete ring parameters: number of rings, locations of the rings, cross-sectional properties, material properties.
- 100 Read in mechanical line loads: axial, circumferential, radial and moment; fixed or initial and eigenvalue or incremental.
- 300 Read in thermal line loads (thermal hoop resultant and thermal moment resultants about two orthogonal axes through the centroid of each discrete ring).
- 500 Read in pressure and surface traction meridional and circumferential distributions.
- 900 Read in temperature rise meridional and circumferential distributions, and variation through the thickness of the shell wall.
- 2000 Read in prescribed prestress distribution if INDIC = 4, IPRE = 0.
- 3000 Read in shell wall construction parameters: monocoque, layered, with or without rings and/or stringers that are "smeared out" in the analysis.
- 5000 End of input for each segment. Go back to the beginning of the loop for the input for the next segment. If this is the last segment, start a new case or type "END".

Number and Distribution of Nodal Points in Segment "ISEG"

12 Continue

```

● NMESS, NTYPEH, 0
  ( 5 ≤ NMESS ≤ 98 )
  ( NTYPEH = 1 or 2 or 3 )
  if NTYPEH = 1:
    ● NHRVALU
    ● (IHRVALU(I), I = 1, NHRVALU)
    ● (HHRVALU(I), I = 1, NHRVALU)
    go to 15
  if NTYPEH = 2:
    ● (HVALU(I), I = 1, NMESS - 1)
    go to 15
  if NTYPEH = 3 (uniform nodal point spacing) go to 15

```

Definitions of Input Variables and Explanation

NMESS = number of "w" nodal points in the segment, ISEG. NMESS is one of the most important variables in the analysis, since it governs to a large extent the accuracy of the solution. A feeling for proper values for NMESS comes with experience. Few points are needed for cases in which the solution is expected to vary slowly along the shell meridian. Points should be concentrated in areas where the solution is expected to vary rapidly. Note that buckling modal displacements may not necessarily vary rapidly in the same areas as prebuckling quantities. A jagged solution for stress or buckling indicates the need for more mesh points.

Limitations on the Total Number of Degrees of Freedom

In the nonlinear prebuckling axisymmetric analysis up to 1000 degrees of freedom (d.o.f.) are permitted. In the linear nonsymmetric stress analysis and nonsymmetric bifurcation buckling and vibration analyses up to 1500 d.o.f. are permitted.

For the axisymmetric analysis the total d.o.f. are given by:

$$\text{d.o.f.} = \sum_{\text{ISEG}=1}^{\text{NSEG}} (\text{NMESS}(\text{ISEG}) + 2) * 2 + 3 * \text{NSEG} + 3 * \text{NCOND}$$

For the nonaxisymmetric analysis, in which there is an additional displacement variable v , the total number of degrees of freedom is:

$$\text{d.o.f.} = \sum_{\text{ISEG}=1}^{\text{NSEG}} (\text{NMESS}(\text{ISEG}) + 2) * 3 + 4 * \text{NSEG} + 4 * \text{NCOND}$$

Location of Finite Difference Nodal Points and Output Points "E"

Figure A3 shows the locations of nodal points in the finite difference energy method. All BOSOR4 output corresponds to the point labeled "E"

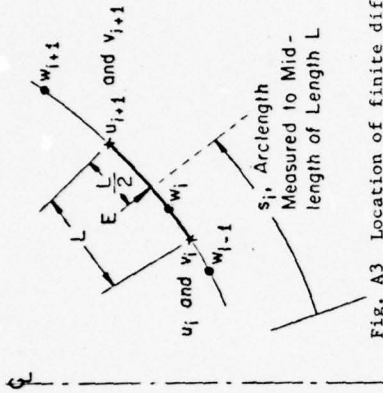
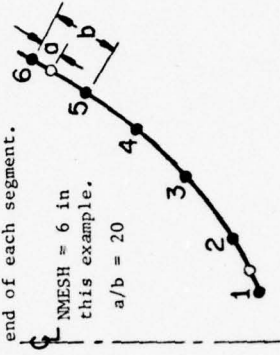

Fig. A3 Location of finite difference nodes and output point "E"

which is the location at which the energy is minimized for each finite difference element. Each "energy point" is located half-way between adjacent u points. As seen from Fig. A3, if the mesh spacing varies, the "energy points" do not coincide with the w points.

Additional w Nodes Automatically Inserted by BOSOR4

Two additional "w" nodes are inserted by BOSOR4 between the first and second and the second-to-last and last points in each segment. This is done in order to reduce the truncation errors associated with boundaries and to prevent spurious modes associated with the fictitious points which lie outside the segment boundaries. If b is the original mesh spacing provided by the user, BOSOR4 inserts the extra w points at a distance $a = b/20$ from each segment end. It is emphasized that the user does not need to consider these extra nodes in making up a case. All input quantities provided by the user are automatically corrected to account for these extra nodes. The figure below shows an example. Note that the addition of the extra w nodes causes the spacing of the output points E to vary near each end of each segment.



- User specified w nodal points.
- Additional nodal points added by BOSOR4 to reduce truncation error at boundaries of shell segments and to prevent spurious buckling or vibration modes.

Definitions of Input Variables and Explanation

NTYPE= control integer for nodal point spacing: 1, 2 = variable; 3 = constant.
 NHVALU= number of values of mesh spacing (distance between adjacent w nodes) which will be read in. Minimum of 2, maximum of 50.
 IHVALU= nodal point callouts for which spacing is to be given. Spacing will vary linearly between these callouts. See Fig. A4.
 HVALU= spacing between adjacent w nodes at callout points.
 HVALU(I) is the meridional arc length between w(IHVALU(I)) and w(IHVALU(I)+1). See Fig. A4 for an example. Only relative sizes of spacing are required, not absolute values.

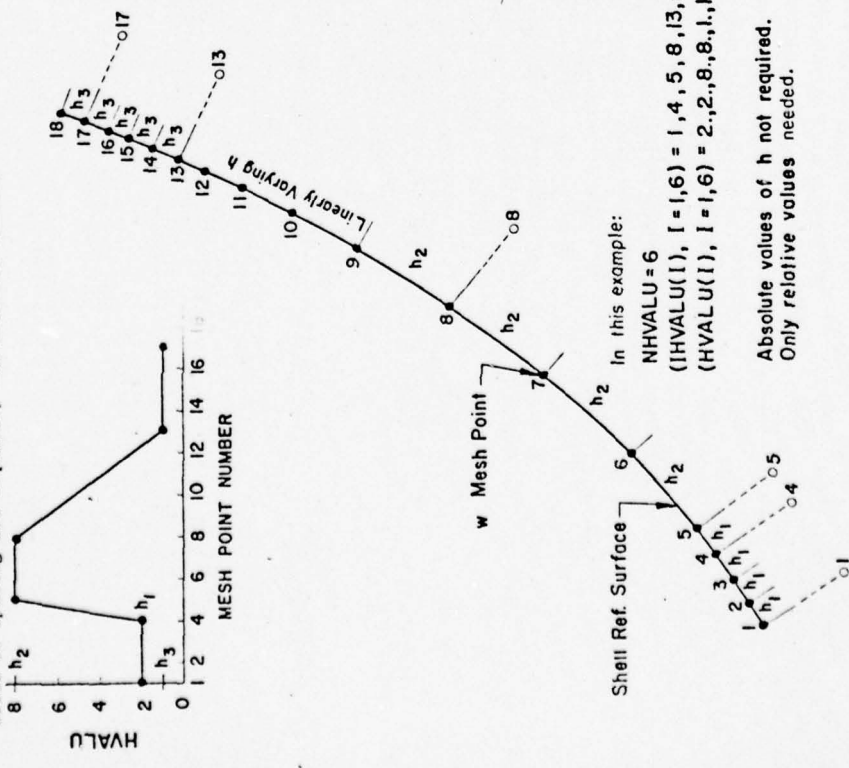

Fig. A4 Input for variable nodal point spacing

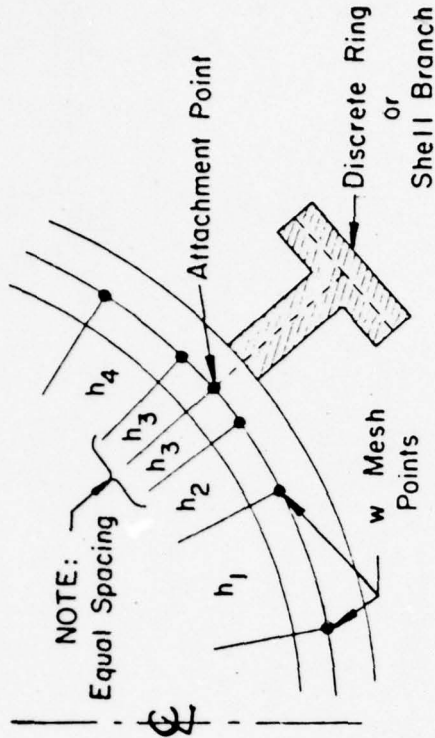

Fig. A5 Appropriate spacing of nodes at discrete ring attachment point or shell branch point

Geometry of the Reference Surface of Shell Segment "ISEG"

15 Continue

● NSHAPE, NTYPEZ, IMP

if NSHAPE = 1:

● R1, Z1, R2, Z2

go to 17



(cylinder, cone, plate)

if NSHAPE = 2:

● R1, Z1, R2, Z2, RC, ZC

● SROT

go to 17

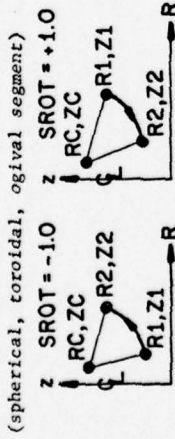

(spherical, toroidal, ogival segment)

if NSHAPE = 4:

● NST (NST = 1 or 4)

if NST = 1:

● NZRIN' (5 ≤ NRZIN ≤ 50)

● Z(I), R(I), I = 1, NRZIN

go to 17



(general meridional shape)

if NST = 4:

● ZMAX, XMAX, ZA, ZB, 50.0, ALPHAT

go to 17

ZA must be less than ZB.



(ellipsoidal segment)

Definitions of Input Variables

NTYPEZ = control integer for location of reference surface relative to the shell wall material:

- 1 means that the distance from the shell wall leftmost surface to the reference surface varies along the meridian. By "leftmost" we mean as we face in the direction of increasing meridional arc length, s.
- 3 means that the distance from the leftmost surface of the wall to the reference surface is constant as we proceed along the meridional arc length, s.

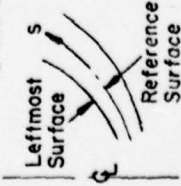

IMP = control integer for imperfection: 0 means none; 1 means some

Imperfection of the Meridional Shape of Segment "ISEG"

17 Continue

if IMP = 0 (no imperfection) go to 20

● ITYPE

(ITYPE = 1 or 2)

if ITYPE = 1:

● FM, C, FLMIN, FLMAX

go to 20

if ITYPE = 2:

● WO, WLENGTH

Definitions of Input Variables

ITYPE = control integer for type of axisymmetric imperfection:

- 1 means sinusoidal series with random amplitudes and wave-lengths,
- 2 means pure sinusoidal.

FM = number of wavelengths to be included in the representation of the imperfection.

C = maximum amplitude of the imperfection.

FLMIN = minimum half-wavelength to be included in the representation of the imperfection.

FLMAX = maximum half-wavelength to be included in the representation of the imperfection.

WO = amplitude of sinusoidal imperfection.

WLENGTH = half-wavelength of sinusoidal imperfection.

NOTE: All imperfections must be axisymmetric. Other imperfection shapes can be investigated by use of the geometry option for general meridional shapes (NSHAPE = 4, NST = 1 on previous page.)

Location of Reference Surface Relative to Shell Wall Material

20 Continue

if NTYPEZ = 1:

- NZVALU (2 ≤ NZVALU ≤ 50)
- NTYPE (NTYPE = 2 or 3)

if NTYPE = 2:

- (Z(I), I = 1, NZVALU)

go to 21

if NTYPE = 3:

- (R(I), I = 1, NZVALU)

21 Continue

- (ZVAL(I), I = 1, NZVALU)

go to 25

if NTYPEZ = 3:

- ZVAL

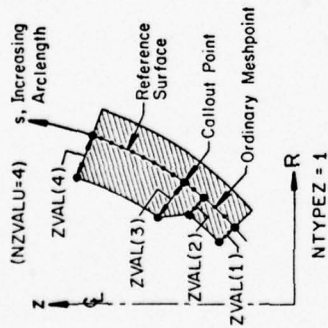

Definitions of Input Variables and Explanation

NTYPEZ = control integer for location of reference surface:

- 1 means that distance from leftmost surface to reference surface varies along the meridional arc length s . The meaning of "leftmost" is illustrated in the figure below.
- 3 means that the distance from the leftmost surface to the reference surface is constant along the meridian.

NZVALU = number of callout points to be used for specification of the location of the reference surface relative to the leftmost surface. This distance at points intermediate to the callout points is determined automatically by linear interpolation.

Z = axial coordinates of callout points. Points must be specified from the beginning of the segment to the end, include the end points of the segment, and be single valued over the segment.

R = radial coordinates of callout points. Same restrictions apply here as for Z.

ZVAL = distance from leftmost surface to reference surface at the callout points identified by Z or R.

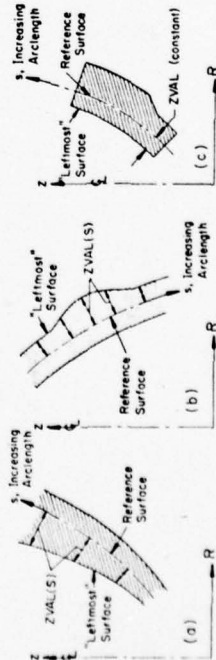

General Comments on Input for Meridionally Varying Quantities

The pattern of input data pertaining to nonconstant reference surface location, ZVAL(I), I = 1, NZVALU, shown on the previous page, is typical for any input quantity that varies along the shell meridian, such as temperature, pressure, and thickness. The number, NZVALU, of stations ("callout points") at which the input quantity is to be specified is first read in; then a control integer, NTYPE, is read in. This integer specifies whether the callout points are to be interpreted as axial distances Z(I) (NTYPE = 2) or radial distances R(I) (NTYPE = 3); then the callout points R(I) or Z(I) are read in; finally the values, ZVAL(I) themselves, are read in. In BOSOR4 the variation of these values along the meridian between callout points is assumed to be linear.

When using the input option corresponding to meridionally varying quantities, the user must always provide input corresponding to the end points of the segment. Values must be provided in order, starting from the beginning of the segment and proceeding to the end.

Corresponding to the figure at the top of the previous page, the input might be:

```

4      NZVALU
2      NTYPE
      (Z(I), I = 1, 4)
0.5, 1.5, 1.85, 3.0
0.5, 0.5, 0.80, 0.8
      (ZVAL(I), I = 1, 4)

```

Discrete Rings in Segment "ISEG"

25 Continue

● NRINGS (0 ≤ NRINGS ≤ 20)

if (NRINGS = 0) (no discrete rings) go to 100

● NTYPE (NTYPE = 2 or 3)

if (NTYPE = 2): ● (Z(I), I = 1, NRINGS)

if (NTYPE = 3): ● (R(I), I = 1, NRINGS)

● (NTYPE(I), I = 1, NRINGS) (NTYPE = 0 or 1 or 2 or 4 or 5)

Do 50 I = 1, NRINGS

if (NTYPE(I) = 0): no data read. This is a fake ring. Go to 50

if (NTYPE(I) = 1): ● E, A, RIV, RIX, RIXY, E1, E2, GJ, RM

if (NTYPE(I) = 2): ● E, A, RIS, RIN, RISN, ZC, SC, GJ, RM

if (NTYPE(I) = 3): do not use this option.

if (NTYPE(I) = 4): ● L(1), T(1), L(2), T(2), L(3), T(3)

● E, U, XLP, Y(1), Y(2), Y(3)

● RM

if (NTYPE(I) = 5): ● same input as for NTYPE(I) = 4, except that X, Y axes (Fig. A6) are considered to be normal and tangential, respectively, to the shell reference surface at the ring attachment point.

50 Continue (end of do-loop over the number of discrete rings)

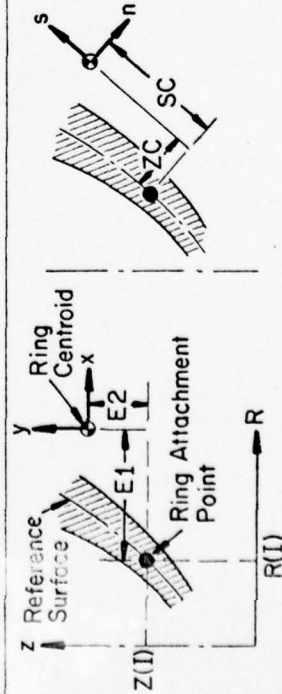

Definitions of Input Variables

NRINGS = number of discrete rings in this segment. Up to 20 rings are permitted in one segment; up to 50 rings in the entire structure. If line loads are applied at some station, the user must supply a fake ring even if no ring is present in the actual structure at that point. This is because all line loads are considered to act at discrete ring centroids.

Z = axial coordinates to ring attachment points, which are considered to be on the shell reference surface. Must be specified from the beginning of the segment to the end and must be single-valued.

R = radial coordinates to ring attachment points. Same restrictions apply here as for Z.

NTYPE = indicator for type of discrete ring. Use 0 if this is a fake ring needed only for a place on which to "hang" a line load.

E, A, RIV, RIX, RIXY = Young's modulus, cross-sectional area, moments of inertia about y axis, x axis, product of inertia. y and x axes are shown in the figure.

E1, E2 = radial, axial distances from ring attachment point to ring centroid. Positive as shown in the figure.

GJ; RM = torsional rigidity; mass density (e.g., aluminum = .0002535).

RIS, RIN, RISN = moments of inertia about s axis, n axis, product of inertia. s and n axes are shown in the figure.

ZC, SC = normal, tangential distances from ring attachment point to ring centroid. Positive as shown on the figure.

L(1), T(1), L(2), T(2), L(3), T(3) = lengths and thicknesses of discrete ring segments shown in Fig. A6.

E, U = Young's modulus, Poisson ratio of ring material.

XLP = radial distance from ring attachment point to first segment of discrete ring, shown in Fig. A6.

Y(1), Y(2), Y(3) = axial distances from ring attachment point to centroids of each of the three segments of the discrete ring. These distances are shown in Fig. A6.

NOTE: Users may occasionally want to simulate a massive structure by a massive discrete ring attached to some point on the meridian. It has been found that such a massive ring should not be attached to the end point of a segment, but must be attached at least three points from either of the segment end points. The reason is that the large mass located at the end of a segment might give rise to a fictitious vibration mode associated with exaggerated motion of the fictitious points located there.

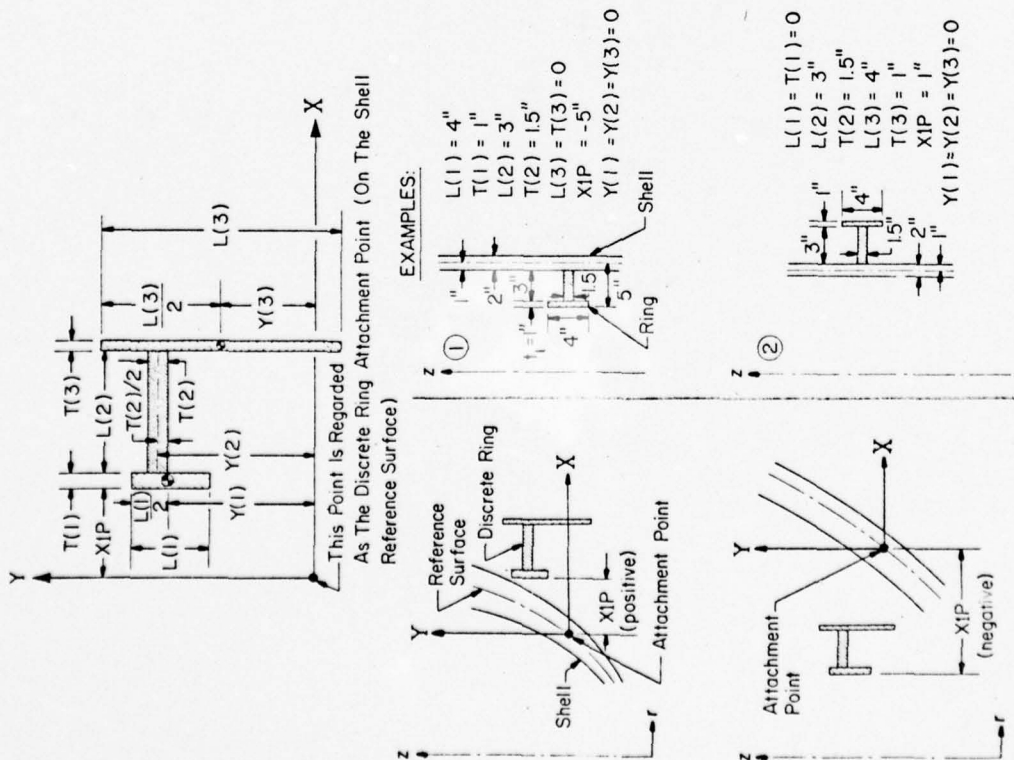

Fig. A6 Input data for discrete ring with use of options NITPER(1) = 4 or 5.

Loading on Shell Segment "ISEG"

Four classes of loads are possible:

1. mechanical line loads applied at centroids of discrete rings
2. thermal line loads at discrete rings
3. pressure and surface tractions distributed over shell surface
4. temperature distribution through thickness and over surface

These loads may be axisymmetric or may vary around the circumference. The pressures and temperatures may vary along the meridian as well as around the circumference, and the temperature may vary through the thickness. In cases involving nonsymmetric loading a linear analysis is used; the program finds the Fourier series for the loads, calculates the shell response in each harmonic to the load components with that harmonic, and superposes the results for all harmonics. The superposed displacements and stress resultants are printed and plotted for selected meridional and circumferential stations. Line loads and moments are assumed to be applied at discrete ring centroids. Thermal line loads arise from the presence of discrete rings which may be heated above their zero-stress states. Distributed thermal loads arise from temperature distributions over the shell surface and through the shell wall thickness. Here the input temperature is actually "delta T," the rise in temperature above the zero-stress state, not the ambient temperature.

In many cases a load is represented in the BOSOR4 program as a product of quantities. For example, the initial normal pressure in a nonlinear axisymmetric stress analysis (INDIC = 0) is represented as a product of a multiplier P and a meridional distribution f(s):

$$p(s) = P \cdot f(s) = P \cdot PN(s) \text{ or } P \cdot (P11 + P12 \cdot s^{P13} + P14 \cdot s^{P15})$$

The normal pressure for each harmonic in a linear nonsymmetric stress analysis (INDIC = 3 or 4) is represented as a product of a meridional distribution PN(s) and a circumferential harmonic amplitude, PDIST1:

$$p(s, \theta) = PN(s) \cdot PDIST1(L, ISEG)$$

A negative normal pressure can be provided by making either of the factors less than zero.

For each class of load there are two types:

1. initial or fixed loads
2. incremental or eigenvalue parameter loads

The appropriate use of these two types of loads has been illustrated by an example of a spherical cap loaded by a combination of axial compression V and external pressure p (Fig. A2). Other examples are given in Tables A3 and A4.

The various load classes and types and the sign convention are given in Table A2. Notice that for completeness, negative as well as zero and positive circumferential wave numbers n must be used for the Fourier expansions of nonsymmetric loads.

Table A4 BOSOR4 Loads Nomenclature, Nonsymmetric Loads		LOAD MAGNITUDES FOR INDIC = 3 AND 4	
LOAD CLASSES AND TYPES		INDIC = 3	INDIC = 4
CLASS 1	Initial or fixed	V(I)*PLIN1(L,ISEG) S(I)*PLIN2(L,ISEG) H(I)*PLIN1(L,ISEG) M(I)*PLIN1(L,ISEG)	not applicable not applicable not applicable not applicable
	Increment or eigenv. parameter	not applicable not applicable not applicable	V(I)*PLIN1(L,ISEG) S(I)*PLIN2(L,ISEG) H(I)*PLIN1(L,ISEG) M(I)*PLIN1(L,ISEG)
CLASS 2	Initial or fixed	TNR(I)*TLIN(L,ISEG) TMX(I)*TLIN(L,ISEG) TMY(I)*TLIN(L,ISEG)	not applicable not applicable not applicable
	Increment or eigenv. parameter	not applicable not applicable not applicable	TNR(I)*TLIN(L,ISEG) TMX(I)*TLIN(L,ISEG) TMY(I)*TLIN(L,ISEG)
CLASS 3	Initial or fixed	PT(J)*PDIST1(L,ISEG) PC(J)*PDIST2(L,ISEG) PN(J)*PDIST1(L,ISEG)	not applicable not applicable not applicable
	Increment or eigenv. parameter	not applicable not applicable not applicable	PT(J)*PDIST1(L,ISEG) PC(J)*PDIST2(L,ISEG) PN(J)*PDIST1(L,ISEG)
CLASS 4	Initial or fixed	FUNCT(T1,T2,T3,z)* TDIST(L,ISEG)	not applicable
	Increment or eigenv. parameter	not applicable	FUNCT(T1,T2,T3,z)* TDIST(L,ISEG)

I = Ith discrete ring in the current segment, ISEG.

J = Jth point in the current segment for which load or temperature

is called out (not the Jth nodal point, but the Jth callout).

L = Lth harmonic to be processed. Note that the circumferential

wave number, n, is not necessarily equal to L:

e.g., L = 1, 2, 3, 4, 5; n = 5, 7, 9, 11, 13

FUNCT(T1,T2,T3,z) is given for three values of NTEGRAD on p. 83,

Sign convention for the loads is given in Table A2.

Table A5 Definitions for Nonsymmetric Load Input Data

For Cases in Which NTYPEL = 4

NTHETA = number of circumferential points for specification of the load variation $g(\theta)$ in the circumferential direction in the range $0 \leq \theta \leq \text{THETAM}$. (THETAM has already been read in. It is usually equal to 180 degrees.) NTHETA must be in the range $2 \leq \text{NTHETA} \leq 100$.

NOPT = control integer for how $g(\theta)$ is going to be provided:

1 means that YPLUS(J) and YMINUS(J), $J = 1, \text{NTHETA}$ are going to be read in. (required for functions that are neither odd nor even about $\theta = 0$ degrees) YPLUS and YMINUS are the values of $g(\theta)$ at the circumferential callout points.

2 means that YPLUS(J) only is going to be read in and that YMINUS(J) can be calculated from YPLUS(J) because the function $g(\theta)$ is either odd or even.

3 means that YPLUS(J) and YMINUS(J) are to be calculated from a user-written subroutine, GETY, an example of which is listed below.

NODD = control integer for oddness or evenness or otherwise of $g(\theta)$:

1 means $g(\theta)$ is even in the range $-\text{THETAM} \leq \theta < \text{THETAM}$.

2 means $g(\theta)$ is odd.

3 means $g(\theta)$ is general (neither even nor odd).

THETA = values of circumferential coordinates of callout points for $g(\theta)$ in degrees. The first value must be 0.0 and the last must be THETAM. All values must be positive and less than or equal to 180 degrees. The values need not be evenly spaced in θ and need not cover the entire range $\theta = 0$ to 180. The range covered, however, must be equal to an integer fraction of π radians (expressed in degrees).

YPLUS = values of $g(\theta)$ at the callout points, THETA.

YMINUS = values of $g(-\theta)$ at the callout points, THETA.

NOTE: The load factors PLIN1(L,ISEG), PLIN2(L,ISEG), TLIN(L,ISEG), PDIST1(L,ISEG), PDIST2(L,ISEG), and TDIST(L,ISEG) in Table A4 are calculated from the input data just described.

Example of User-Written Subroutine GETY

```

SUBROUTINE GETY(NTHETA, THETA, YMINUS, YPLUS)
DIMENSION THETA(NTHETA), YMINUS(NTHETA), YPLUS(NTHETA)
DO 10 I = 1, NTHETA
YPLUS(I) = EXP(-12.8*THETA(I)**2)
10 YMINUS(I) = YPLUS(I)
RETURN
END

```

(NOTE: in Sub. GETY THETA(I) is in radians!)

Mechanical Line Loads on Shell Segment "ISEG"
100 Continue

```

if (INDIC = 4) and (IPRE = 0) go to 2000 (prebuckling stress
resultants to be read
in directly as input)
  ● LINTYP (LINTYP = 0 or 1 or 2 or 3)
if (LINTYP = 0 or 2) or if (NRINGS = 0) go to 300 (no line loads)
if (INDIC = 3 or 4): ● NTYPEL (NTYPEL = 3 or 4)
  ● NLOAD(1), NLOAD(2), NLOAD(3), NLOAD(4) (NLOAD(j) = 0 or 1)
if (NLOAD(1) = 1): ● (V(I), I = 1, NRINGS)
if (NLOAD(2) = 1): ● (S(I), I = 1, NRINGS)
if (NLOAD(3) = 1): ● (H(I), I = 1, NRINGS)
if (NLOAD(4) = 1): ● (FM(I), I = 1, NRINGS)
if (INDIC = 3 or 4) go to 105
  ● NLOAD(1), 0, NLOAD(3), NLOAD(4) (NLOAD(j) = 0 or 1)
if (NLOAD(1) = 1): ● (DV(I), I = 1, NRINGS)
if (NLOAD(3) = 1): ● (DH(I), I = 1, NRINGS)
if (NLOAD(4) = 1): ● (DM(I), I = 1, NRINGS)

```

Axisymmetric mechanical line loads have now been read in for seg. "ISEG"
go to 300

105 if (NTYPEL = 4) go to 120

```

● PLIN1(L, ISEG), L = 1, number of Fourier harmonics)
● PLIN2(L, ISEG), L = 1, number of Fourier harmonics)

```

Nonsymmetric mechanical line loads have now been read in for seg. "ISEG"
go to 300

120 if (NLOAD(1) = 0 and NLOAD(3) = 0 and NLOAD(4) = 0) go to 140

```

● NTHETA, NOPT, NODD
● (THETA(J), J = 1, NTHETA)
if NOPT = 1: ● (YPLUS(J), J = 1, NTHETA)
  ● (YMINUS(J), J = 1, NTHETA)
if NOPT = 2: ● (YPLUS(J), J = 1, NTHETA)
if NOPT = 3: ● CALL GETY(NTHETA, THETA, YMINUS, YPLUS)

```

140 if (NLOAD(2) = 0) go to 300

```

● NTHETA, NOPT, NODD
● (THETA(J), J = 1, NTHETA)
if NOPT = 1: ● (YPLUS(J), J = 1, NTHETA)
  ● (YMINUS(J), J = 1, NTHETA)
if NOPT = 2: ● (YPLUS(J), J = 1, NTHETA)
if NOPT = 3: ● CALL GETY(NTHETA, THETA, YMINUS, YPLUS)

```

NOTE: The definitions for NTHETA, NOPT, NODD, etc. are given in Table A5.

Definitions of Input Variables and Explanation

INDIC = analysis type. INDIC = 3 means linear nonsymmetric stress analysis; INDIC = 4 means nonsymmetric stress with buckling. IPRE = 1 if prestress is calculated by BOSOR4; 0 if prestress is to be read in as input data.

LINTYP = 0 for no line loads; 1 for mechanical line loads only; 2 for thermal line loads only; 3 for both mech. and thermal. NRINGS = number of discrete rings in this segment, including fake rings required for ringless stations with line loads.

NTYPEL = 3 if Fourier amplitudes for circumferential distribution of line loads to be read in for n = NSTART to NFIN in steps of INCR.

4 if line load amplitudes at various circumferential stations are to be read in or computed by user-written subroutine GETY.

NOTE: Line loads in each segment must be expressible as a product $f(I) \cdot g(\theta)$, where I represents the Ith discrete ring. $g(\theta)$ can differ from segment to segment, but must involve the same circumferential wave numbers, n = NSTART to NFIN in increments or decrements of INCR, for all segments. The Fourier series for V, H, and FM must be identical in a given segment. The Fourier series for S may be different.

V, S, H, FM = fixed or initial axial, shear, radial, and moment line load factors. See Table A4 and the equations below. DV, DH, DM = incremental or eigenvalue axial, radial, and moment line load factors. See Table A3.

NOTE: 1. Line loads are assumed to act at the centroids of discrete rings. They are positive as shown in the figure under Table A2.

2. With n = 0 or n = ±1 circumferential waves, the user must make sure either that these harmonics of the loads are in static equilibrium or that the constraint conditions prevent rigid body displacements. The user need not provide input for line load reactions, which do no work during deformations.

PLIN1(L, ISEG) = amplitude factors for axial, radial, moment loads. PLIN2(L, ISEG) = amplitude factors for shear load. See Table A4.

NOTE: 1. Maximum number of circumferential harmonics is 20
2. Circumferential wave numbers associated with these harmonics are n = NSTART to NFIN in steps of INCR. They may be positive or negative or both.
3. The various line loads at the Ith discrete ring and at a circumferential station θ are given by:

$$\begin{matrix}
 V(I) \\
 S(I) \\
 H(I) \\
 FM(I)
 \end{matrix}
 *
 \left\{ \sum_{n=NSTART,1}^{N, L=NFIN, \text{no. of harmonics}} \right.
 \begin{matrix}
 PLIN1(L, ISEG) * \sin n\theta + PLIN1(L, ISEG) * \cos n\theta \\
 PLIN2(L, ISEG) * \cos n\theta + PLIN2(L, ISEG) * \sin n\theta \\
 PLIN1(L, ISEG) * \sin n\theta + PLIN1(L, ISEG) * \cos n\theta \\
 PLIN1(L, ISEG) * \sin n\theta + PLIN1(L, ISEG) * \cos n\theta
 \end{matrix}
 \left. \right\}
 \begin{matrix}
 \text{positive n} \\
 \text{negative n} \\
 \Delta N = \text{INCR}
 \end{matrix}$$

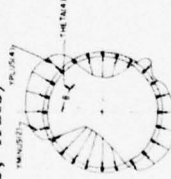

Thermal Line Loads on Shell Segment, "ISEG"

```

300 Continue
    if (LINTYP = 0 or 1) or if (NRINGS = 0) go to 500 (no line loads)
    if (INDIC = 3 or 4): ● NTYPEL (NTYPEL = 3 or 4)
    ● NLOAD (1), NLOAD(2), NLOAD(3) (NLOAD(j) = 0 or 1)
    if (NLOAD(1) = 1) ● ( TNR(I), I = 1, NRINGS)
    if (NLOAD(2) = 1) ● ( TMX(I), I = 1, NRINGS)
    if (NLOAD(3) = 1) ● ( TMY(I), I = 1, NRINGS)
    if (INDIC = 3 or 4) go to 305
    ● 0, 0, 0
  
```

Axisymmetric thermal line loads have now been read in for segment "ISEG." go to 500

```

305 if (NTYPEL = 4) go to 320
    ● (TLIN(L,ISEG), L = 1, number of Fourier harmonics)
  
```

Nonsymmetric thermal line loads have now been read in for segment "ISEG." go to 500

```

320 if (NLOAD (1) = 0 and NLOAD(2) = 0 and NLOAD(3) = 0) go to 500
  
```

```

    ● NTHETA, NOPT, NODD
    ● (THETA(J), J = 1, NTHETA)
    if NOPT = 1: ● ( YPLUS(J), J = 1, NTHETA)
                 ● (YMINUS(J), J = 1, NTHETA)
    if NOPT = 2: ● ( YPLUS(J), J = 1, NTHETA)
    if NOPT = 3: ● CALL GETY(NTHETA, THETA, YMINUS, YPLUS)
  
```

NOTE: The definitions for NTHETA, NOPT, NODD, etc. are given in Table A5.

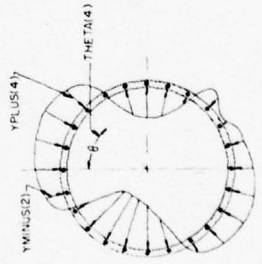

Definitions of Input Variables and Explanations

- LINTYP = 0 for no line loads; 1 for mechanical line loads only; 2 for thermal line loads only; 3 for both mech. and thermal
- NRINGS = number of discrete rings in this segment, including fake rings required for ringless stations with line loads.
- NTYPEL = 3 if Fourier amplitudes for circumferential distribution of line loads are to be read in for n = NSTART to NFIN in steps of INCR.
- 4 if line load amplitudes at various circumferential stations are to be read in or computed by user-written subroutine GETY.

NOTE: With INDIC = 3 or 4 the line loads in each segment must be expressible as a product $f(I)*g(\theta)$, where I represents the Ith discrete ring. $g(\theta)$ can differ from segment to segment, but must involve the same circumferential wave numbers, $n = NSTART$ to $NFIN$ in increments or decrements of INCR, for all segments. The Fourier series for TNR, TMX, and TMY must be identical in a given segment.

TNR, TMX, TMY = thermal hoop load, moment about x axis, moment about y axis. These quantities are obtained from the formulas in Table A2 for load class #2. The "t" in those formulas is a temperature rise distribution. The actual temperature in the ring is the distribution t times the multiplier, TEMP or DTEMP, or times the circumferential harmonic, TLIN, depending on the type of analysis. See Tables A3 and A4 for details.

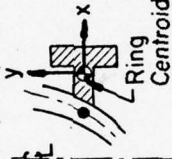

TLIN(L,ISEG) = circumferential harmonic amplitude factors for TNR, TMX, TMY. See Table A4.

- NOTE:
- Maximum number of circumferential harmonics is 20
 - Circumferential wave numbers associated with these harmonics are $n = NSTART$ to $NFIN$ in steps of INCR. They may be positive or negative or both.
 - The various thermal line loads at the Ith discrete ring and at a circumferential station θ are given by:

$$\begin{matrix} \text{TNR(I)} \\ \text{TMX(I)} \\ \text{TMY(I)} \end{matrix} * \sum_{\substack{N, L = NSTART, 1 \\ \Delta N = INCR}}^{N, L = NFIN, \text{no. of harmonics}} \underbrace{\begin{matrix} \text{TLIN(L, ISEG)*sin } n\theta + \text{TLIN(L, ISEG)*cos } n\theta \\ \text{TLIN(L, ISEG)*sin } n\theta + \text{TLIN(L, ISEG)*cos } n\theta \\ \text{TLIN(L, ISEG)*sin } n\theta + \text{TLIN(L, ISEG)*cos } n\theta \end{matrix}}_{\substack{\text{positive } n \\ \text{negative } n}}$$

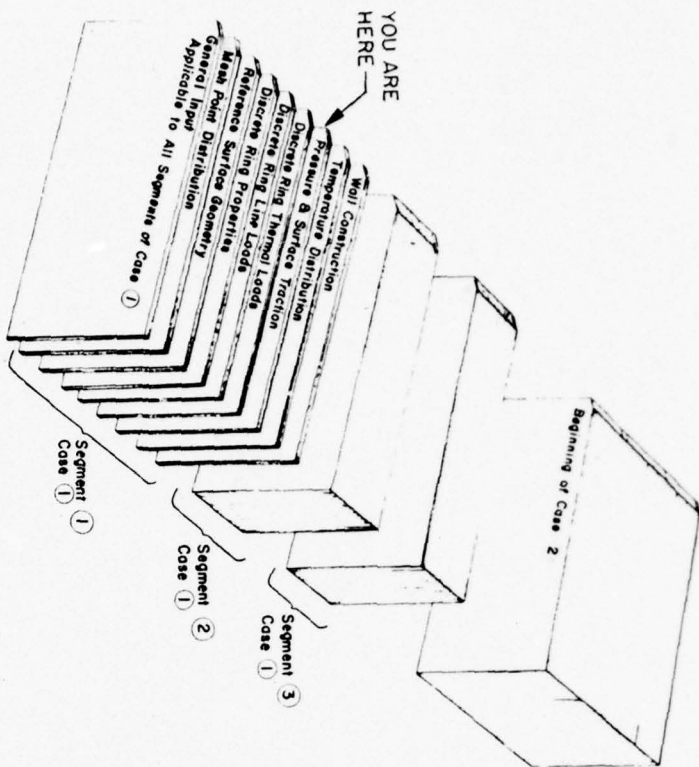

BOSOR4 Data Deck

Loads and Temperatures Distributed over the Surface of Segment "ISEG"
500 Continue

● NLTYPE, NPSTAT, NSTAT, NTCRAD

Definitions of Input Variables

NLTYPE = control integer for type of loading:

- 0 = no pressure, surface traction of temperature distribution on this shell segment.
- 1 = pressure and/or surface traction, but no temperature distribution on this shell segment.
- 2 = temperature distribution, but no pressure or surface traction on this shell segment.
- 3 = pressure and/or surface traction and temperature distribution on this shell segment.

NPSTAT = number of meridional stations in this segment for which pressure and surface traction components will be read in. If INDIC = 3 or 4 and NLTYPE = 1 or 3 NPSTAT must be greater than or equal to 2, and less than or equal to 20. The NPSTAT = 0 option can be used only for INDIC = -2, -1, 0, 1, and 2.

NSTAT = number of meridional stations in this segment for which temperature rise coefficients T1, T2, and T3 will be read in. Same discussion applies here as for NPSTAT.

NTCRAD = control integer for type of thermal gradient through the shell wall thickness:

- 1 means $T(s,z) = T1(s) + T2(s)*z + T3(s)*z^2$
- 2 means $T(s,z) = T1(s) + T2(s)*z + T3(s)$
- 3 means $T(s,z) = T1(s) + T2(s)*exp(z*T3(s))$



where z is measured from the reference surface positive to the right of increasing meridional arc length, s. In Tables A3 and A4 the function T(s,z) is called "FUNCT." The actual temperature magnitude is given by T(s,z)*TEMP or T(s,z)*DTEMP for INDIC = -2, -1, 0, 1, or 2, and for each circumferential harmonic by T(s,z)*TDIST(L,ISEG) for INDIC equal to 3 or 4.

Pressure and Surface Traction on Shell Segment "ISEG"

if (NLTYPE = 0) or (NLTYPE = 2) go to 900 (no pressure or surface traction)

if (NPSTAT greater than 0) go to 510

- P11, P12, P13, P14, P15
- P21, P22, P23, P24, P25

go to 900

510 if (INDIC = 3 or 4): ● NTYPEL (NTYPEL = 3 or 4)

(NLOAD(j) = 0 or 1)

● NLOAD(1), NLOAD(2), NLOAD(3)

if (NLOAD(1) = 1): ● (PT(I), I = 1, NPSTAT)

if (NLOAD(2) = 1): ● (PC(I), I = 1, NPSTAT)

if (NLOAD(3) = 1): ● (PN(I), I = 1, NPSTAT)

if (INDIC ≠ 3) and (INDIC ≠ 4) go to 700

if (NTYPEL = 4) go to 520

● (PDIST1(L, ISEG), L = 1, number of harmonics)

● (PDIST2(L, ISEG), L = 1, number of harmonics)

go to 700

520 if (NLOAD(1) = 0 and NLOAD(3) = 0) go to 530

● (NTHETA, NOPT, NODD)

● (THETA(J), J = 1, NTHETA)

if NOPT = 1: ● (YPLUS(J), J = 1, NTHETA)

● (YMINUS(J), J = 1, NTHETA)

if NOPT = 2: ● (YPLUS(J), J = 1, NTHETA)

if NOPT = 3: ● CALL GETY(NTHETA, THETA, YMINUS, YPLUS)

530 if (NLOAD(2) = 0) go to 700

● (NTHETA, NOPT, NODD)

● (THETA(J), J = 1, NTHETA)

if NOPT = 1: ● (YPLUS(J), J = 1, NTHETA)

● (YMINUS(J), J = 1, NTHETA)

if NOPT = 2: ● (YPLUS(J), J = 1, NTHETA)

if NOPT = 3: ● CALL GETY(NTHETA, THETA, YMINUS, YPLUS)

700 Continue

● NTYPE

(NTYPE = 2 or 3)

if (NTYPE = 2): ● (Z(I), I = 1, NPSTAT)

if (NTYPE = 3): ● (R(I), I = 1, NPSTAT)

NOTE: The definitions for NTHETA, NOPT, NODD, etc. are given in Table A5.

Definitions of Input Variables and Explanation

NLTYPE = 0 for no loading; 1 for pressure and surface tractions only; 2 for temperature only; 3 for both pressure and temperature.

NPSTAT = number of meridional callout points for pressure.

P11, P12, P13, P14, P15 = coefficients for $f(s) = P11 + P12 * s^{P13} + P14 * s^{P15}$ in which s is the meridional arc length from the beginning of the segment. This function corresponds to the meridional distribution of the normal pressure. As seen in Table A3, the actual pressure is a product $P * f(s)$ or $DP * f(s)$.

P21, P22, P23, P24, P25 = coefficients for $g(s)$ of same form as $f(s)$; $g(s)$ refers to meridional traction.

NTYPEL = 3 if Fourier amplitudes for circumferential distribution of loads are to be read in for $n = NSTART$ to $NFIN$ in steps of INCR.

4 if load amplitudes at various circumferential stations are to be read in or computed by user-written subroutine GETY.

NOTE: With INDIC = 3 or 4 the pressure and surface tractions in each segment must be expressible as a product $f(s) * g(\theta)$. $g(\theta)$ can differ from segment to segment, but must involve the same circumferential wave numbers, $n = NSTART$ to $NFIN$ in increments or decrements of INCR, for all segments. The Fourier series for normal and meridional components must be identical; that for the circumferential component can be different.

PT(I), PC(I), PN(I) = meridional, circumferential, normal components at the Ith meridional callout point. Sign convention is shown in the figure beneath Table A2. See Table A4 and below.

PDIST1(L, ISEG) = amplitude factors for meridional traction and normal pressure.

PDIST2(L, ISEG) = amplitude factors for circumferential traction.

NOTE: 1. Maximum number of circumferential harmonics is 20.
2. Circumferential wave numbers associated with these harmonics are $n = NSTART$ to $NFIN$ in steps of INCR. They may be positive or negative or both.
3. The various surface loads at the Ith meridional callout and at a circumferential station θ are given by:

$$\begin{Bmatrix} PT(I) \\ PC(I) \\ PN(I) \end{Bmatrix} * \sum_{\substack{N, L = NFIN, \text{ no. of harmonics} \\ \Delta N = INCR}} \begin{Bmatrix} PDIST1(L, ISEG) * \sin n\theta + PDIST1(L, ISEG) * \cos n\theta \\ PDIST2(L, ISEG) * \cos n\theta + PDIST2(L, ISEG) * \sin n\theta \\ PDIST1(L, ISEG) * \sin n\theta + PDIST1(L, ISEG) * \cos n\theta \end{Bmatrix} \begin{matrix} \text{positive } n \\ \text{negative } n \end{matrix}$$

Z(I) = axial coordinate of Ith meridional callout point where surface load components are specified.

R(I) = radial coordinate of Ith meridional callout point where surface load components are specified.

Temperature Distribution in Shell Segment "ISEG"

900 Continue

```

if (NLTYPE = 0) or (NLTYPE = 1) go to 3000 (no temperature)
if (NSTAT greater than 0) go to 910
  ● T11, T12, T13, T14, T15
  ● T21, T22, T23, T24, T25
  ● T31, T32, T33, T34, T35
go to 3000
910 if (INDIC = 3 or INDIC = 4): ● NTYPEL (NTYPEL = 3 or 4)
  ● NLOAD(1), NLOAD(2), NLOAD(3) (NLOAD(j) = 0 or 1)
  if (NLOAD(1) = 1): ● (T1(I), I = 1, NSTAT)
  if (NLOAD(2) = 1): ● (T2(I), I = 1, NSTAT)
  if (NLOAD(3) = 1): ● (T3(I), I = 1, NSTAT)
  if (INDIC # 3) and (INDIC # 4) go to 970
  if (NTYPEL = 4) go to 920
  ● (TDIST(L,ISEG), L = 1, number of harmonics)
go to 970

```

```

920 if (NLOAD(1) = 0 and NLOAD(2) = 0 and NLOAD(3) = 0) go to 3000
  ● NTHETA, NOPT, NODD
  ● (THETA(J), J = 1, NTHETA)
  if NOPT = 1: ● (YPLUS(J), J = 1, NTHETA)
  ● (YMINUS(J), J = 1, NTHETA)
  if NOPT = 2: ● (YPLUS(J), J = 1, NTHETA)
  if NOPT = 3: ● CALL GETY(NTHETA, THETA, YMINUS, YPLUS)

```

970 Continue

```

  ● NTYPE (NTYPE = 2 or 3)
  if (NTYPE = 2): ● (Z(I), I = 1, NSTAT)
  if (NTYPE = 3): ● (R(I), I = 1, NSTAT)

```

NOTE: The definitions for NTHETA, NOPT, NODD, etc. are given in Table A5.

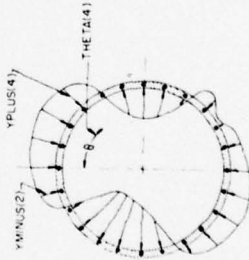

Definitions of Input Variables and Explanation

NLTYPE = 0 for no loading; 1 for pressure and surface tractions only; 2 for temperature only; 3 for both pressure and temperature.

NSTAT = number of meridional callout points for temperature.

T11, T12, T13, T14, T15 Coefficients for T1(s), T2(s), and T3(s) which appear in the functions of temperature with thickness coordinate, z, given previously in connection with NTEGRAD.

For example, the function $T1(s) = T11 + T12*s^{T13} + T14*s^{T15}$. The other functions T2(s) and T3(s) have the same form. Note that the actual temperature rise distribution is the function $T(s,z) = FUNCT(T1(s), T2(s), T3(s), z)$ multiplied by TEMP or DTEMP if INDIC = -2, -1, 0, 1, or 2 and by TDIST(L,ISEG) if INDIC = 3 or 4. See Tables A3 and A4 and the equations below.

NTYPEL = 3 if Fourier amplitudes for circumferential distribution of temperature are to be read in for n = NSTART to NFIN in steps of INCR.

4 if temperature amplitudes at various circumferential stations are to be read in or computed by user-written subroutine GETY.

NOTE: With INDIC = 3 or 4 the temperature in each segment must be expressible as a product $f(s)*g(\theta)$. $g(\theta)$ can differ from segment to segment, but must involve the same circumferential wave numbers, n = NSTART to NFIN in increments or decrements of INCR, for all segments.

T1(I), T2(I), T3(I) = temperature rise coefficients at Ith meridional callout point. These are the coefficients that appear in the functions of temperature with thickness coordinate z given in connection with the description associated with NTEGRAD.

TDIST(L,ISEG) = amplitude factors for circumferential distribution of temperature.

NOTE: 1. Maximum number of circumferential harmonics is 20.
2. Circumferential wave numbers associated with these harmonics are n = NSTART to NFIN in steps of INCR. They may be positive or negative or both.
3. The temperature rise coefficients T1, T2, T3 at the Ith meridional callout and at a circumferential station θ are:

$$\begin{Bmatrix} T1(I) \\ T2(I) \\ T3(I) \end{Bmatrix} * \sum_{N,L=NSTART,1}^{N,L=NFIN, \text{no. of harmonics}} \underbrace{\begin{Bmatrix} TDIST(L,ISEG)*\sin n\theta + TDIST(L,ISEG)*\cos n\theta \\ TDIST(L,ISEG)*\sin n\theta + TDIST(L,ISEG)*\cos n\theta \\ TDIST(L,ISEG)*\sin n\theta + TDIST(L,ISEG)*\cos n\theta \end{Bmatrix}}_{\substack{\text{positive n} \\ \text{negative n}}} \underbrace{\quad}_{N=INCR}$$

Z(I) = axial coordinate of the Ith meridional callout point where temperature rise coefficients are specified.

R(I) = radial coordinate of the Ith meridional callout point where temperature rise coefficients are specified.

Prestress Input Data for Option INDIC = 4, IPRE = 0, Segment "ISEG"

2000 Continue

if (INDIC # 4) or (IPRE # 0) go to 3000

• NSTRES, NRLOAD

if (NSTRES = 0) go to 2100

• NTYPE

if (NTYPE = 2): • (Z(I), I = 1, NSTRES)

if (NTYPE = 3): • (R(I), I = 1, NSTRES)

• (FN10(I), I = 1, NSTRES)

• (FN20(I), I = 1, NSTRES)

• (CH10(I), I = 1, NSTRES)

2100 if (NRLOAD = 0) go to 3000

• (IRING(I), I = 1, NRLOAD)

• (RLOAD(I), I = 1, NRLOAD)

Definitions of Input Variables

INDIC analysis type; INDIC = 4 means buckling with nonsymmetric prestress

IPRE used only with INDIC = 4; 0 = prestress meridional distribution read in, 1 = prestress meridional distribution calculated

NSTRES ... number of stations along the meridian in segment ISEG for which prestress resultants FN10 and FN20 and meridional rotation CH10 will be read in (less than 50)

NRLOAD ... number of discrete rings in entire shell for which pre-buckling hoop loads will be read in; note that NRLOAD applies to all of the preloaded rings in the entire shell, an exception to the segment-by-segment handling of the input data in BOSOR4. This quantity is read in only with data associated segment #1 (less than 50).

Z(I) axial coordinate of the Ith mesh point callout where prestresses FN10(I), FN20(I), and meridional rotation CH10(I) are to be specified

R(I) radial coordinate of the Ith mesh point callout

FN10(I) .. meridional prestress resultant at Ith mesh point callout (positive for tension)

FN20(I) .. circumferential prestress resultant at Ith mesh point callout (tension positive)

CH10(I) .. meridional prestress rotation at Ith mesh point callout (positive for clockwise rotation, as with M in the figure beneath Table A2)

IRING(I) . index number of discrete ring with hoop prestress RLOAD(I). Indices for all preloaded discrete rings are read in when ISEG = 1.

RLOAD(I) . hoop preload in discrete rings; tension is positive. Read in data for all preloaded discrete rings in shell when ISEG, the current segment number, equals one.

Never include input for IRING or RLOAD if ISEG is greater than 1.

NOTE: Prestresses and meridional rotation vary linearly between stations where they are called out. Be sure to include the first and last points in the segment as callout points.

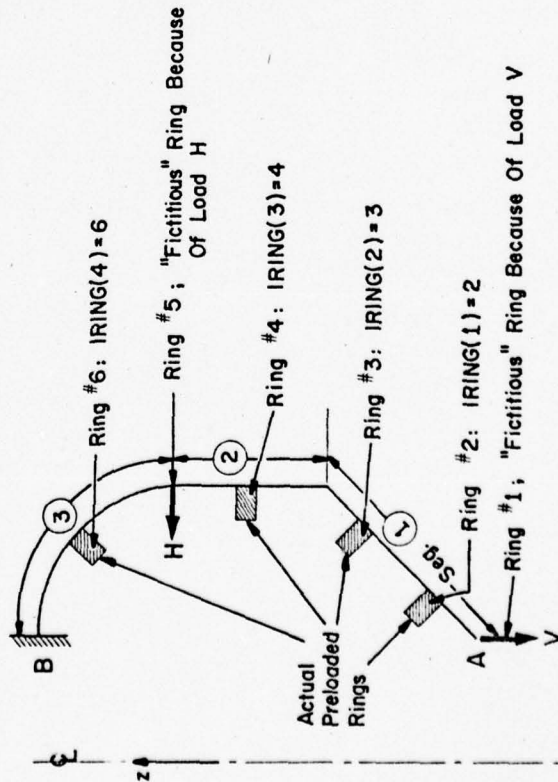

Fig. A7 Actual and fictitious rings

The following special branches calling for simple input data are provided:

1. general wall; the C(i,j) are read in, see the equation below
2. monocoque wall
3. shells with skew stiffeners
4. fiber-reinforced shells laid up in layers (e.g., fiberglass)
5. layered shells with orthotropic layers
6. corrugated shells
7. corrugated semisandwich shells
8. layered shells with orthotropic layers, each layer of which has temperature-dependent material properties

Any of these types of shells can be reinforced by two types of stiffeners: 1. rings and stringers which are "smeared out" in the analysis and 2. rings which are treated as discrete elastic structures.

The discrete ring input data has already been described. The shell wall properties are permitted to vary along the meridian. The smeared ring and stringer properties are also permitted to vary along the meridian. The wall properties of each segment are specified independently of those of the other segments.

In BOSOR4 the wall properties of each segment are determined in one of the subroutines CFBI, CFB2, etc. Each of these subroutines calculates the coefficients C(i,j) of the constitutive equations which relate stress and moment resultants to reference surface strains and changes in curvature:

$$\begin{Bmatrix} N_1 \\ N_2 \\ N_{12} \\ M_1 \\ M_2 \\ M_{12} \end{Bmatrix} = [C] \begin{Bmatrix} \epsilon_1 \\ \epsilon_2 \\ \epsilon_{12} \\ \kappa_1 \\ \kappa_2 \\ 2\kappa_{12} \end{Bmatrix}$$

$$[C] = \begin{bmatrix} C_{11} & C_{12} & 0 & C_{14} & C_{15} & 0 \\ C_{12} & C_{22} & 0 & C_{24} & C_{25} & 0 \\ 0 & 0 & C_{33} & 0 & 0 & C_{36} \\ C_{14} & C_{24} & 0 & C_{44} & C_{45} & 0 \\ C_{15} & C_{25} & 0 & C_{45} & C_{55} & 0 \\ 0 & 0 & C_{36} & 0 & 0 & C_{66} \end{bmatrix}$$

In the BOSOR4 analysis it is always assumed that the meridional and circumferential independent variables s and θ can be separated. Thus, certain of the C(i,j) are assumed to be zero. This is a limitation of the BOSOR4 analysis, although in most cases not a serious one.

In the following pages input data for all of the wall construction options except 3, 6, and 7 are identified. For input data for options 3, 6, and 7 the reader is referred to the BOSOR4 User's Manual [1].

Wall Construction (continued), NWALL and GENERAL C(i,j)

3000 Continue

- NWALL (NWall = 1, 2, 3, 4, 5, 6, 7, 8)

go to (3100, 3200, 3300, 3400, 3500, 3600, 3700, 3800), NWALL

3100 Continue

(NWall = 1, general C(i,j))

- SMPA
- C11, C12, C14, C15, C22, C24
- C25, C33, C44, C45, C55, C66
- C36, ANRS (ANRS = 0.0 or 1.0)

if (ANRS=1.0) ● read data as directed in Table A6.

go to 5000

(end of input for segment ISEG)

Definitions of Input Variables

NWALL = control integer for choice of wall construction:

- 1 = general C(i,j)
- 2 = monocoque
- 3 = skew-stiffened, constant properties along meridional arc
- 4 = fiberwound, layered, constant thickness; smeared stiffeners possible
- 5 = layered orthotropic; variable thickness; smeared stiffeners possible
- 6 = corrugated; properties constant along meridian; smeared stiffeners possible
- 7 = corrugated with one smooth skin (semi-sandwich); Smooth skin can have variable thickness; smeared stiffeners
- 8 = layered orthotropic with temperature-dependent material properties; variable thickness; smeared stiffeners o.k.

NWALL = 1 input data description:

SMPA = shell wall mass/area

C11, C12, etc. = coefficients in the constitutive law given on the previous page.

ANRS = control variable for addition of smeared stiffeners:

- 0.0 means no smeared stiffeners to be added to wall
- 1.0 means yes smeared stiffeners to be added. (Note that adding the smeared stiffeners will change the C(i,j).)

Wall Construction (continued): MONOCOQUE (NWALL = 2)

3200 Continue

(NWALL = 2, monocoque wall)

● E, U, SM, ALPHA, ANRS, SUR

if (SUR = -1.0): ● NTYPEP

(NTYPEP = 1 or 2 or 3)

if (NTYPEP = 1): ● NTVAlU

● NTYPE

(NTYPE = 2 or 3)

if (NTYPE = 2): ● (Z(I), I = 1, NTVAlU)

if (NTYPE = 3): ● (R(I), I = 1, NTVAlU)

● (TVAL(I), I = 1, NTVAlU)

if (NTYPEP = 2): ● TH1, TH2, TH3, TH4, TH5

if (NTYPEP = 3): ● TVAL

if (ANRS = 1.0): ● read data as directed in Table A6.

go to 5000

(end of input for segment ISEG)

Description of Input Variables

E, U = Young's modulus, Poisson ratio.

SM = mass density (e.g., aluminum = 0.0002535 lb-sec²/in.⁴).

ALPHA = coefficient of thermal expansion.

ANRS = 0.0 for no smeared stiffeners to be added,

1.0 for yes smeared stiffeners to be added.

SUR = control variable for thickness input:

0.0 means reference surface is the middle surface. Since we already know the distance from the leftmost surface to the reference surface, we do not need any more data to determine the wall thickness.

1.0 means the reference surface is the outer or rightmost surface. This is the same as the distance from the leftmost surface to the reference surface, which has already been read in. Hence, no additional data are needed for specification of the shell thickness.

-1.0 means that the reference surface is arbitrarily located with respect to the leftmost surface. (It might be the leftmost surface itself.) Therefore, additional data will be needed for specification of the thickness.

NTVALU= number of meridional callout points for which the thickness will be read in.

Z(I) = axial coordinate to the Ith meridional callout for thickness

R(I) = radial coordinate to the Ith meridional callout for thickness

TVAL(I) = thickness at the Ith meridional callout; thickness varies

linearly between meridional stations where it is called out

TH1, TH2, TH3, TH4, TH5 = coefficients in t(s)=TH1 + TH2*s TH3 + TH4*s TH5

TVAL = thickness (constant in this segment)

Wall Construction (continued), Fiberwound, Layered (NWALL = 4)

3400 Continue

(NWALL = 4, fiberwound layered)

● EF, EM, UF, UM, AK, ANRS

● (T(I), I = 1, AK)

● (X(I), I = 1, AK)

● (BE(I), I = 1, AK)

● (C(I), I = 1, AK)

● (SM(I), I = 1, AK)

if (ANRS = 1.0): ● read data as directed in Table A6.

go to 5000

(end of input for segment ISEG)

Description of Input Variables

EF = Young's modulus for fibers

EM = Young's modulus for matrix

UF = Poisson ratio for fibers

UM = Poisson ratio for matrix

AK = number of layers (maximum is 20.0) (floating point input!)

ANRS = 0.0 for no smeared stiffeners to be added

1.0 for yes smeared stiffeners to be added

T(I) = thickness of layer; leftmost layer is no. 1; rightmost layer is no. AK.

X(I) = matrix content by volume of Ith layer

BE(I) = winding angle (degrees) between fiber direction and meridian

C(I) = contiguity factor: 0.2 to 0.3 is the usual range

SM(I) = mass density of Ith layer. (aluminum = .0002535 lb-sec²/in.⁴)

Wall Construction (continued): Layered Orthotropic (NWALL = 5)

3500 Continue

(NWALL = 5, Layered orthotropic)

```

● WRAPS, ANRS, TYPEI
if (TYPEP = 0.0): ● (T(I), I = 1, WRAPS)
● ( G(I), I = 1, WRAPS)
● ( EX(I), I = 1, WRAPS)
● ( EY(I), I = 1, WRAPS)
● ( UXY(I), I = 1, WRAPS)
● ( SM(I), I = 1, WRAPS)
● (ALPHA1(I), I = 1, WRAPS)
● (ALPHA2(I), I = 1, WRAPS)
if (TYPEP = 1.0): ● NTIN
● NTYPE
if (TYPEP = 2): ● (Z(I), I = 1, NTIN)
if (TYPEP = 3): ● (R(I), I = 1, NTIN)
if (TYPEP = 1.0): Do 3550 I = 1, WRAPS
3550 ● (TIN(J), J = 1, NTIN)
if (ANRS = 1.0): ● read data as directed in Table A6.
go to 5000 (end of input for segment ISEG)

```

Description of Input Data

WRAPS = number of layers (maximum is 20.0) (floating point input!)
 ANRS = 0.0 for no smeared stiffeners to be added
 1.0 for yes smeared stiffeners to be added
 TYPEP = 0.0 layer thicknesses constant; 1.0 layer thicknesses vary
 I(I) = thickness of Ith layer. I = 1 is leftmost, = WRAPS is rightmost
 G(I) = shear modulus of Ith layer
 EX(I) = modulus in meridional direction
 EY(I) = modulus in circumferential direction
 UXY(I) = Poisson ratio
 SM(I) = mass density (e.g., aluminum = .0002535 lb-sec²/in.⁴)
 ALPHA1(I) = coefficient of thermal expansion in meridional direction
 ALPHA2(I) = coefficient of thermal expansion in circumfer. direction
 NTIN = number of meridional callouts for which thicknesses of all layers will be read in
 Z(I) = axial coordinates of meridional callouts for thicknesses
 R(I) = radial coordinates of meridional callouts for thicknesses
 TIN(J) = thickness of a layer at the Jth meridional callout

NOTE: thicknesses vary linearly between meridional callouts.

Wall Construction (continued): Layered Orthotropic with Temperature-Dependent Material Properties (NWALL = 8)

3800 Continue

NWALL = 8, temp. dependent props)

(TYPEP = 0.0 or 1.0)

● WRAPS, ANRS, TYPEI

```

if (TYPEP = 0.0): ● (T(I), I = 1, WRAPS)
go to 3900

```

```

if (TYPEP = 1.0): ● NTIN
● NTYPE

```

(NTYPE = 2 or 3)

```

if (NTYPE = 2): ● (Z(I), I = 1, NTIN)
if (NTYPE = 3): ● (R(I), I = 1, NTIN)

```

```

if (TYPEP = 1.0): Do 3850 I = 1, WRAPS

```

3850 ● (TIN(J), J = 1, NTIN)

```

3900 ● ( SM(I), I = 1, WRAPS)
● ( NPOINT(I), I = 1, WRAPS)

```

```

Do 3950 I = 1, WRAPS

```

```

● (HEAT(I,K), K = 1, NPOINT(I))
● ( G(K,I), K = 1, NPOINT(I))
● ( EX(K,I), K = 1, NPOINT(I))
● ( EY(K,I), K = 1, NPOINT(I))
● ( UXY(K,I), K = 1, NPOINT(I))
● ( A1(K,I), K = 1, NPOINT(I))
● ( A2(K,I), K = 1, NPOINT(I))

```

3950 Continue

if (ANRS = 1.0): ● read data as directed in Table A6.

go to 5000 (end of input data for this segment)

Description of Input Variables

WRAPS = number of layers (maximum is 5.0) (floating point input!)
 ANRS = 0.0 for no smeared stiffeners; 1.0 for yes stiffeners
 TYPEP = 0.0 for constant thicknesses; 1.0 for variable thicknesses
 I(I) = thickness of Ith layer; I = 1 is leftmost, = WRAPS is rightmost
 NTIN = number of meridional callouts for layer thicknesses
 Z(I) = axial coordinates of meridional callouts for thicknesses
 R(I) = radial coordinates of meridional callouts for thicknesses
 TIN(J) = thickness of a layer at the Jth meridional callout

NOTE: thicknesses vary linearly between meridional callouts.

SM(I) = mass density of Ith layer material

NPOINT(I) = number of temperature values for which properties of the Ith layer are given; maximum of 20 values/layer

HEAT(I,K) = temperature above zero-stress temperature for which wall properties of the Ith layer will be read in

G(K,I) = shear modulus of Ith layer at the Kth temperature, HEAT(I,K)

EX(K,I) = Young's modulus in meridional direction, Ith layer, Kth temp

EY(K,I) = Young's modulus in circumfer. direction, Ith layer, Kth temp

UXY(K,I) = Poisson ratio; note that EY*UXY = EX*UYX

A1(K,I) = thermal expansion coefficient in meridional direction

A2(K,I) = thermal expansion coefficient in circumferential direction

NOTE: The temperature multiplier TEMP must be unity for this option!

Table A6 "Smeared" Stringer and Ring Properties in Segment "ISEC"

(The following data are to be read in if ANRS = 1.0 for the NWALL option, even if no stringers or rings are present.)

● IRECT1, IRECT2, IVAR1, IVAR2 (IRECT, IVAR = 0 or 1)

if (IRECT1 = 1) and (IVAR1 = 0) ● N1, K1
 ● E1, U1, STIFMD
 ● T1, H1
 go to 4000 (stringer input done)

if (IRECT1 = 1) and (IVAR1 = 1) ● NSTATN, N1, K1
 ● NTYPE (NTYPE = 2 or 3)
 if (NTYPE=2): ● (Z(I), I = 1, NSTATN)
 if (NTYPE=3): ● (R(I), I = 1, NSTATN)
 ● E1, U1, STIFMD
 Do 3970 I = 1, NSTATN
 3970 ● T(I), H(I)
 go to 4000 (stringer input done)

if (IRECT1 = 0) and (IVAR1 = 0) ● N1, K1
 ● E1, U1, STIFMD
 ● XS, AL, X11, XJ1
 go to 4000 (stringer input done)

if (IRECT1 = 0) and (IVAR1 = 1) ● NSTATN, N1, K1
 ● NTYPE (NTYPE = 2 or 3)
 if (NTYPE=2): ● (Z(I), I = 1, NSTATN)
 if (NTYPE=3): ● (R(I), I = 1, NSTATN)
 ● E1, U1, STIFMD
 Do 3980 I = 1, NSTATN
 3980 ● X(I), A(I), XI(I), XJ(I)
 go to 4000 (stringer input done)

IRECT1 = 1 for stringers with rectangular cross section

0 for stringers with arbitrary cross section

IVAR1 = 1 for stringers with properties varying along meridian

0 for stringers with constant properties along meridian

N1 = number of stringers in 360 degrees

K1 = 0 for stringers attached to leftmost surface; 1 rightmost surf.

E1, U1, STIFMD = stringer modulus, Poisson ratio, mass density

T1; H1 = stringer thickness (dimension parallel to shell wall); height

NSTATN = number of meridional callouts for stringer properties

Z(I) = axial coordinates to meridional callout points

R(I) = radial coordinates to meridional callout points

T(I), H(I) = stringer thickness, height at meridional callout point

XS = distance from neutral axis of stringer to closest shell surface

AL = cross-sectional area of stringer

X11= centroidal moment of inertia about axis parallel to circumference

XJ1= torsional constant J

X(I) = distance from neutral axis to closest shell surf. at Ith callout

A(I) = cross-sectional area of stringer at Ith meridional callout

XI(I) = centroidal moment of inertia about axis parallel to circumference

XJ(I) = torsional constant J of stringer at Ith meridional callout

Table A6 (continued) "Smeared" Ring Properties in Segment "ISEC"

(The following data are to be read in if ANRS = 1.0 for the NWALL option, even if no smeared rings are present.)

4000 Continue

if (IRECT2 = 1) and (IVAR2 = 0) ● K2

● E2, U2, RGMND

● D2, T2, H2

go to 5000 (ring input done)

if (IRECT2 = 1) and (IVAR2 = 1) ● NRINGS, K2

● NTYPE (NTYPE = 2 or 3)

if (NTYPE=2): ● (Z(I), I = 1, NRINGS)

if (NTYPE=3): ● (R(I), I = 1, NRINGS)

● E2, U2, RGMND

Do 4100 I = 1, NRINGS

4100 ● D(I), T(I), H(I)

go to 5000 (ring input done)

if (IRECT2 = 0) and (IVAR2 = 0) ● K2

● E2, U2, RGMND

● XR, D2, A2, X12, XJ2

go to 5000 (ring input done)

if (IRECT2 = 0) and (IVAR2 = 1) ● NRINGS, K2

● NTYPE (NTYPE = 2 or 3)

if (NTYPE=2): ● (Z(I), I = 1, NRINGS)

if (NTYPE=3): ● (R(I), I = 1, NRINGS)

● E2, U2, RGMND

Do 4200 I = 1, NRINGS

4200 ● K(I), D(I), A(I), XI(I), XJ(I)

(end of input for this segment)

5000 Continue

IRECT2 = 1 for rings with rectangular cross sections

0 for rings with arbitrary cross sections

IVAR2 = 1 for rings with properties which vary along the meridian

0 for rings with constant properties along the meridian

K2 = 0 for rings attached to the leftmost surface; 1 rightmost surf.

E2, U2, RGMND = ring modulus, Poisson ratio, mass density

D2 = arc length between adjacent rings (constant over segment)

T2; H2 = ring thickness (dimension parallel to shell wall), height

NRINGS = number of meridional callouts for ring properties

Z(I) = axial coordinates to meridional callout points

R(I) = radial coordinates to meridional callout points

T(I), H(I) = ring thickness, height at Ith meridional callout

D(I) = average ring spacing at the Ith meridional callout

XR = distance from neutral axis of ring to closest shell surface

A2 = cross-sectional area of ring

X12= centroidal moment of inertia about axis parallel to meridian

XJ2= ring torsional constant, J

X(I) = distance from neutral axis to closest shell surf. at Ith callout

A(I) = average ring cross-sectional area at Ith meridional callout

XI(I) = average ring centroidal moment of inertia at Ith callout

XJ(I) = average ring torsional constant J at Ith meridional callout

How to Run a Case with Smeared Stiffeners Including Thermal Effects

It is not possible to use the smeared stiffener option (Table 9) if the smeared stiffeners experience a temperature rise above or drop below their zero-stress (reference) temperature. However, such a problem can be solved by treatment of the stiffeners as a shell layer or layers as shown below. The NWall = 5 option (orthotropic layered shell) is used.

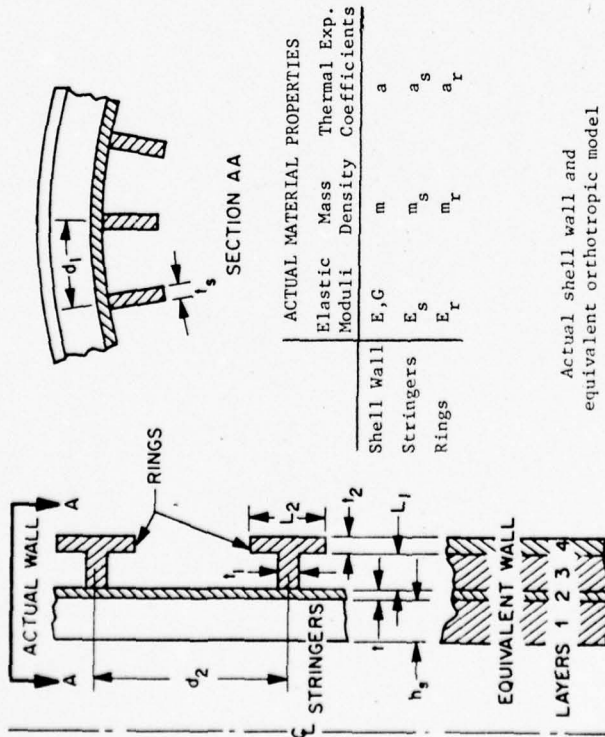

Shell Wall Layer	Thickness	G	EX	EY	UXY	SM	A1	A2
1	h_s	0	$E_s t / d_1$	0	0	$m_s t / d_1$	a_s	0
2	t	G	E	E	ν	m	a	a
3	L_1	0	0	$E_r t_1 / d_2$	0	$m_r t_1 / d_2$	0	a_r
4	t_2	0	0	$E_r t_2 / d_2$	0	$m_r t_2 / d_2$	0	a_r

Orthotropic Material Properties (NWall=5)

SAMPLE CASES

This section contains input data for 7 cases which test all of the analysis branches, INDIC = -2, -1, 0, 1, 2, 3, and 4. Table A7 summarizes the cases and gives reasons why each case was chosen as a demonstration. The BOSOR4 user is urged to consult this table and the sample input on the following pages whenever he encounters difficulties in solving problems similar to these.

Table A7 Sample Cases for BOSOR4

INDIC	CASE NAME	THE PURPOSE OF THE CASE IS TO DEMONSTRATE:
1	Aluminum Frame Buckling	1. linear bifurcation buckling 2. branched shells 3. various locations of reference surface 4. two different failure modes, local and general, leading to two minimum critical loads $p(n)$
-1	Cylinder Buckling	1. nonlinear bifurcation buckling 2. "smeared" stiffeners 3. variable node point spacing 4. discrete rings 5. fake ring for line load 6. hydrostatic pressure: $V = pr/2$ 7. change of boundary conditions from prebuckling to buckling analysis 8. local and general instability
0	Uniformly Loaded Plate	1. nonlinear axisymmetric stress analysis 2. two load steps for linear and nonlinear action
2	Hemisphere Vibration	1. modal vibration analysis 2. rigid body displacement constraint conditions
3	Cylinder with Three Point Loads	1. linear nonsymmetric stress analysis 2. modeling of concentrated loads 3. modeling discrete ring at symmetry plane 4. variable node point spacing 5. point loads repeating at regular intervals around the circumference
4	Buckling of Cone Heated on Axial Strip	1. bifurcation buckling of nonaxisymmetrically loaded shell 2. load which varies along the meridian 3. variable node point spacing
-2	Spherical Cap Buckling	1. nonlinear bifurcation buckling by successive calculation of the stability determinant 2. sign convention of pressure depending on the direction of travel along a meridian 3. problem in which axisymmetric collapse load and bifurcation buckling load are fairly close

Example of Aluminum Frame Buckling

INDIC	NPRT	NLAST	ISTRES	IPRE	TITLE					
1, 2, 0, 0, 0	NSEG	NCOND	IBOUND	IRICID	ALUMINUM FRAME BUCKLING (INDIC=1)					
3, 3, 0, 0	NSTART	NFIN	INCR							
0, 0, 0, 0	NOB	NMINB	NMAXB	INCRB	NVEC					
2, 2, 14, 4, 1	NDIST	NCIRC	NTHETA							
0, 0, 0, 0	(ITHETA(1))	I = 1	NCIRC							
0, 0, 0, 0	(THETA(1))	I = 1	NDIST							
0, 0, 0, 0	THETAM	THETAS	0							
1, 1, 1, 1, 1, 0, 0, 0, 0, 0	IS1	IP1	IS2	IP2	IU*	IV	IW*	IX	DI	D2
1, 6, 2, 1, 1, 1, 1, 1, 0, 0, 0	IS1	IP1	IS2	IP2	IU*	IV	IW*	IX	DI	D2
2, 10, 3, 4, 1, 1, 1, 1, 0, 0, 0	IS1	IP1	IS2	IP2	IU*	IV	IW*	IX	DI	D2
0, -1, 0, 0, 0	P	DP	TEMP	DTEMP						
0, 0, 0, 0	FSTART	FMAX	DF							
11, 3, 0	NMESH	NTYPEH	0Segment #1						
1, 3, 0	NSHAPE	NTYPEZ	IMP							
5.218, 0, 5.218, .453	R1	Z1	R2	Z2						
0	ZVAL									
0	NRINGS									
0	LINTYP									
1, 0, 0, 0	NLTYPE	NPSTAT	NTSTAT	NTGRAD						
1, 0, 0, 0, 0, 0	P11	P12	P13	P14	P15					
0, 0, 0, 0, 0, 0	P21	P22	P23	P24	P25					
2	NWALL									
10800000, .333, 0, 0, 0, 0, -1	E	U	SM	ALPHA	ANRS	SUR				
3	NTYPET									
.182	TVAL									
10, 3, 0	NMESH	NTYPEH	0Segment #2						
1, 3, 0	NSHAPE	NTYPEZ	IMP							
5.218, .2265, 4.882, .2265	R1	Z1	R2	Z2						
.0075	ZVAL									
0	NRINGS									
0	LINTYP									
0, 0, 0, 0	NLTYPE	NPSTAT	NTSTAT	NTGRAD						
2	NWALL									
10800000, 0.333, 0, 0, 0, 0, 0	E	U	SM	ALPHA	ANRS	SUR				
7, 3, 0	NMESH	NTYPEH	0Segment #3						
1, 3, 0	NSHAPE	NTYPEZ	IMP							
4.882, .182, 4.882, .271	R1	Z1	R2	Z2						
.015	ZVAL									
0	NRINGS									
0	LINTYP									
0, 0, 0, 0	NLTYPE	NPSTAT	NTSTAT	NTGRAD						
2	NWALL									
10800000, 0.333, 0, 0, 0, 0, 1	E	U	SM	ALPHA	ANRS	SUR				

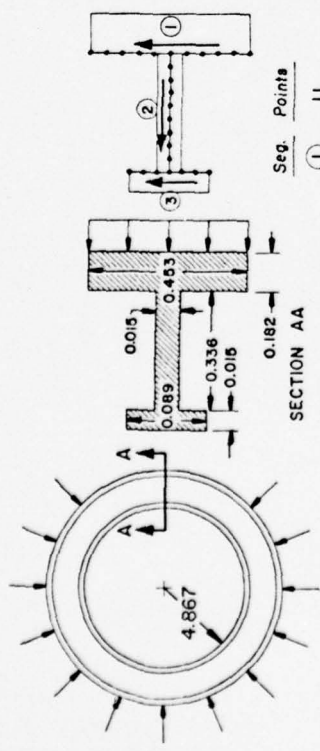

SECTION AA
 $E = 10.8 \times 10^6$ psi
 $\nu = 0.333$

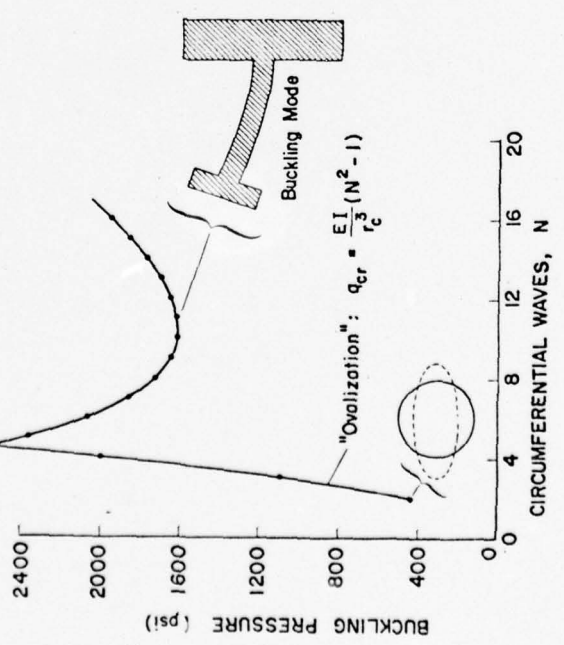
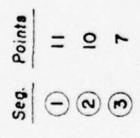

Fig. A8 Aluminum frame buckling (INDIC = 1)

Example of Cylinder Buckling

```

TITLE
INDIC, NPRT, NLAST, ISTRS, IPRE
NSEG, NCOND, IBOUND, IRIGID
NSTART, NFIN, INCR
NOB, NMINB, NMAXB, INCRB, NVEC
NDIST, NCIRC, NTHETA
(ITHETA(I), I = 1, NCIRC)
( THETA(I), I = 1, NDIST)
THETAM, THETAS, 0.
ISI, IPI, IS2, IP2, IU*, IV, IW*, IX, DI, D2
ISI, IPI, IS2, IP2, IU*, IV, IW*, IX, DI, D2
ISI, IPI, IS2, IP2, IU*, IV, IW*, IX, DI, D2
ISI, IPI, IS2, IP2, IU*, IV, IW*, IX, DI, D2
IUB*, IVB, IWB*, IXB
IUB*, IVB, IWB*, IXB
IUB*, IVB, IWB*, IXB
P, DP, TEMP, DTEMP
FSTART, FMAX, DF
NMESH, NTYPEH, 0 .....Segment #1
NHVALU
(IHVALU(I), I = 1, NHVALU)
( HVALU(I), I = 1, NHVALU)
NSHAPE, NTYPEZ, IMP
R1, Z1, R2, Z2
ZVAL
NRINGS
NTYPE
Z(1)
NTYPEP(1) (fake ring)
LINTYP
(NLOAD(M), M = 1,4)
(NLOAD(M), M = 1,4)
DV(1) (DV = DP*RI/2.)
NLTYPE, NPSTAT, NPSTAT, NTCGRAD
P11, P12, P13, P14, P15
P21, P22, P23, P24, P25
NVALL
E, U, SM, ALPHA, ANRS, SUR
IRECT1, IRECT2, IVAR1, IVAR2
N1, K1
E1, U1, STIFMD
T1, H1
K2
E2, U2, RGMD
D2, T2, H2
    
```

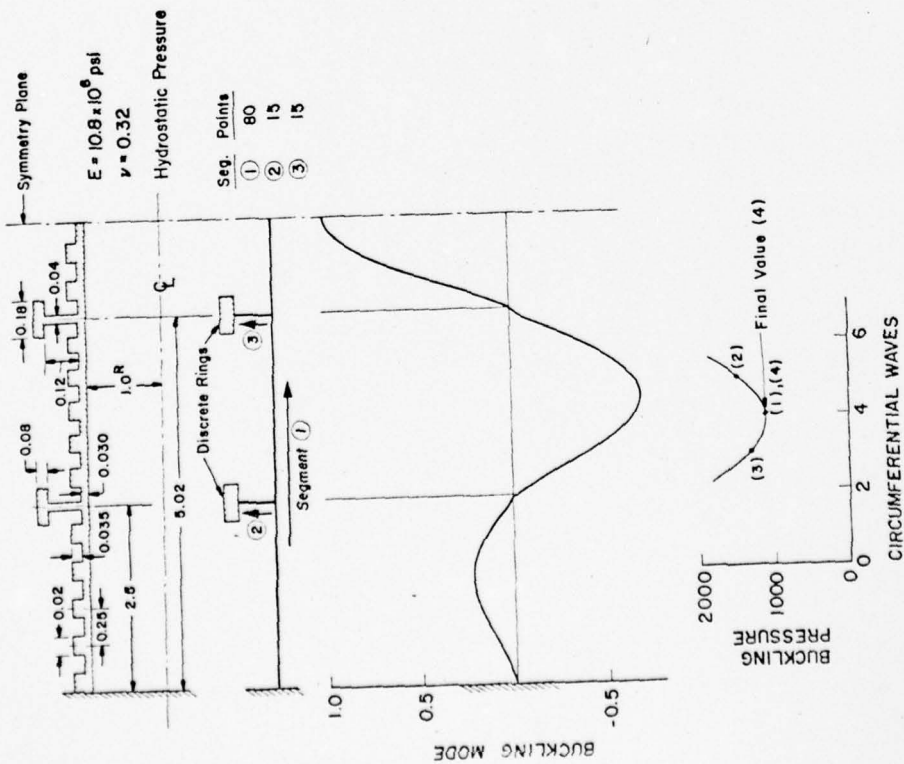

Fig. A9 Cylinder buckling (INDIC = -1)

```

15, 1, 0
3
1, 13, 14
1., 1., .5
1, 3, 0
1.015, 2.5, 1.150, 2.5
.02
1
NRINGS
3
R(1)
1.150
1
NTYPE(1)
E, A, RIXY,
R1X, R1XY, E1, E2, GJ, RM
LINTYP
0
NLTYPE, NSTAT, NTSTAT, NTCRAD
2
NWALL
10800000., .32, 0., 0., 0., 0.
15, 1, 0
3
1, 13, 14
1., 1., .5
1, 3, 0
1.015, 5.02, 1.150, 5.02
.02
1
NRINGS
3
R(1)
1.150
1
NTYPE(1)
E, A, RIXY,
R1X, R1XY, E1, E2, GJ, RM
LINTYP
0
NLTYPE, NSTAT, NTSTAT, NTCRAD
2
NWALL
10800000., 0.32, 0., 0., 0., 0.
E, U, SM, ALPHA, ANRS, SUR
    
```

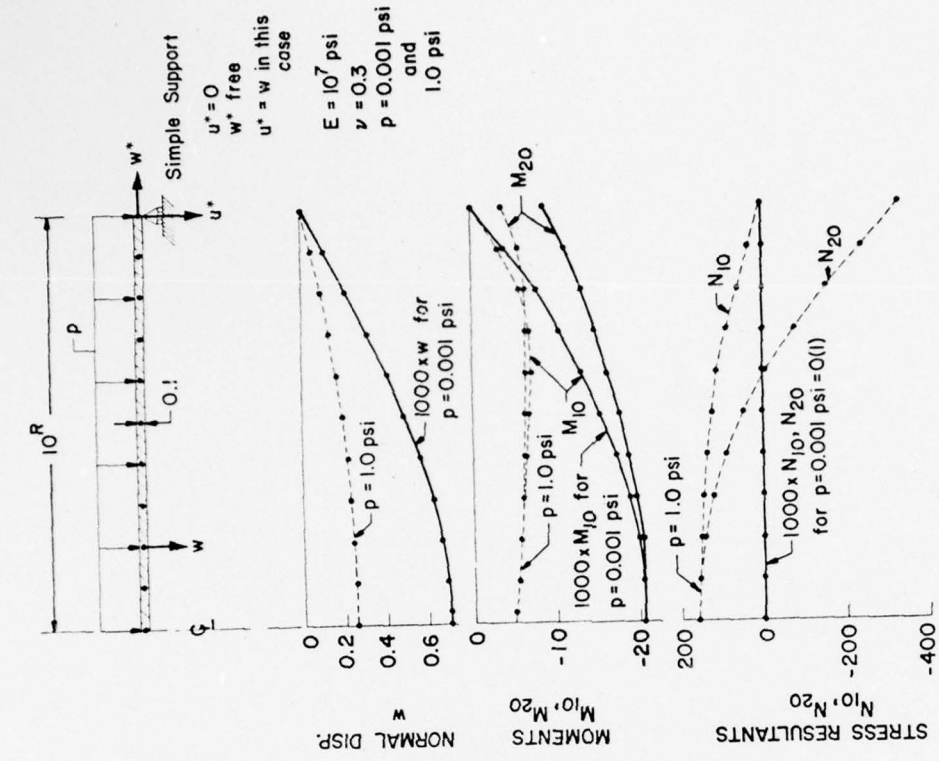

Fig. A10 Uniformly loaded plate (INDIC = 0)

Note: In this case, the boundary conditions for the prebuckling analysis are different from those of the bifurcation buckling analysis. In the prebuckling analysis u^* is free at segment 1, point 1, as indicated on the first IS1, IP1, IS2, IP2, etc. card, and the rest of the displacement components, v, w^* , and λ are set equal to zero. In the bifurcation buckling analysis this boundary is clamped; all displacement components are set equal to zero, as seen from the first card for IUB*, IVB, IWB*, and IXB. This change from prebuckling to buckling analysis is necessary because the axial load $DV=DP*R1/2$ arising from the hydrostatic pressure must be permitted to do work in the axisymmetric prebuckling phase of the problem. Axial motions are restrained in the nonsymmetric buckling phase by a large end ring which was present in the test of this specimen, but which is not included in the analytical model.

Example of Uniformly Loaded Plate

```

UNIFORMLY LOADED PLATE (INDIC= 0) TITLE
0, 2, 0, 1, 0 INDIC, NPRT, NLAST, ISTRS, IPRE
1, 2, 0, 0 NSEG, NCOND, IBOUND, IIRIGID
0, 0, 0 NSTART, NFIN, INCR
0, 0, 0, 0, 0 NOB, NMINB, NMAXB, INCRB, NVEC
0, 0, 0, 0, 0 NDIST, NCIRC, NTHETA
0 (THETA(1), I = 1, NCIRC)
0 (THETA(1), I = 1, NDIST)
0 THETAM, THETAS, 0.
1, 1, 1, 1, 0, 0, 0, 0, 0, 0, 0. IS1, IP1, IS2, IP2, IU*, IV, IW*, IX, D1, D2
1, 11, 1, 11, 1, 1, 0, 0, 0, 0, 0. IS1, IP1, IS2, IP2, IU*, IV, IW*, IX, D1, D2
.001, .999, 0., 0. P, DP, TEMP, DTEMP
.001, 1.0, .999 FSTART, FMAX, DF
11, 3, 0 NMESS, NTYPEH, 0 .....Segment #1
1, 3, 0 NSHAPE, NTYPEZ, IMP
0., 0., 10., 0. R1, Z1, R2, Z2
.05 ZVAL
0 NRINGS
0 LINTYP
1, 0, 0, 0 NLTYP, NPSTAT, NTSTAT, NTGRAD
1, 0, 0, 0, 0, 0. P11, P12, P13, P14, P15
0, 0, 0, 0, 0, 0. P21, P22, P23, P24, P25
2 NWALL
10000000., 0.3, 0., 0., 0., 0. E, U, SM, ALPHA, ANRS, SUR

```

```

HEMISPHERE VIBRATION (INDIC = 2) TITLE
2, 2, 0, 0, 0 INDIC, NPRT, NLAST, ISTRS, IPRE
1, 2, 0, 1 NSEG, NCOND, IBOUND, IIRIGID
0, 0, 0 NSTART, NFIN, INCR
0, 0, 3, 1, 3 NOB, NMINB, NMAXB, INCRB, NVEC
0, 0, 0, 0, 0 NDIST, NCIRC, NTHETA
0 (THETA(1), I = 1, NCIRC)
0 (THETA(1), I = 1, NDIST)
0 THETAM, THETAS, 0.
1, 1, 1, 1, 0, 0, 0, 0, 0, 0. IS1, IP1, IS2, IP2, IU*, IV, IW*, IX, D1, D2
1, 31, 1, 31, 0, 0, 0, 0, 0, 0. IS1, IP1, IS2, IP2, IU*, IV, IW*, IX, D1, D2
1, 31, 1, 31, 1, 1, 0, 0, 0, 0 IS1, IP1, IS1, IP1, IUR*, IVR, IW*, IX
1, 31, 1, 31, 1, 1, 0, 0 IS1, IP1, IS1, IP1, IUR*, IVR, IW*, IX
0., 0., 0., 0. P, DP, TEMP, DTEMP
0., 0., 0. FSTART, FMAX, DF
31, 3, 0 NMESS, NTYPEH, 0 .....Segment #1
2, 3, 0 NSHAPE, NTYPEZ, IMP
0., 0., 100., 100., 0., 100. R1, Z1, R2, Z2, RC, ZC
-1.0 SROT
.5 ZVAL
0 NRINGS
0 LINTYP
0, 0, 0, 0 NLTYP, NPSTAT, NTSTAT, NTGRAD
2 10000000., 0.3, .0002535, 0., 0., 0. E, U, SM, ALPHA, ANRS, SUR

```

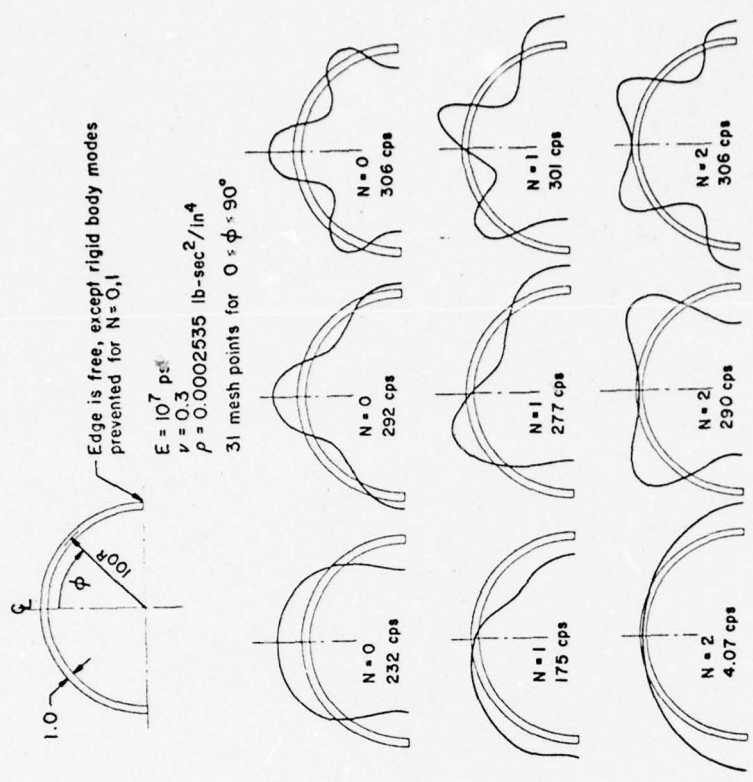

Fig. A11 Hemisphere vibration (INDIC = 2)

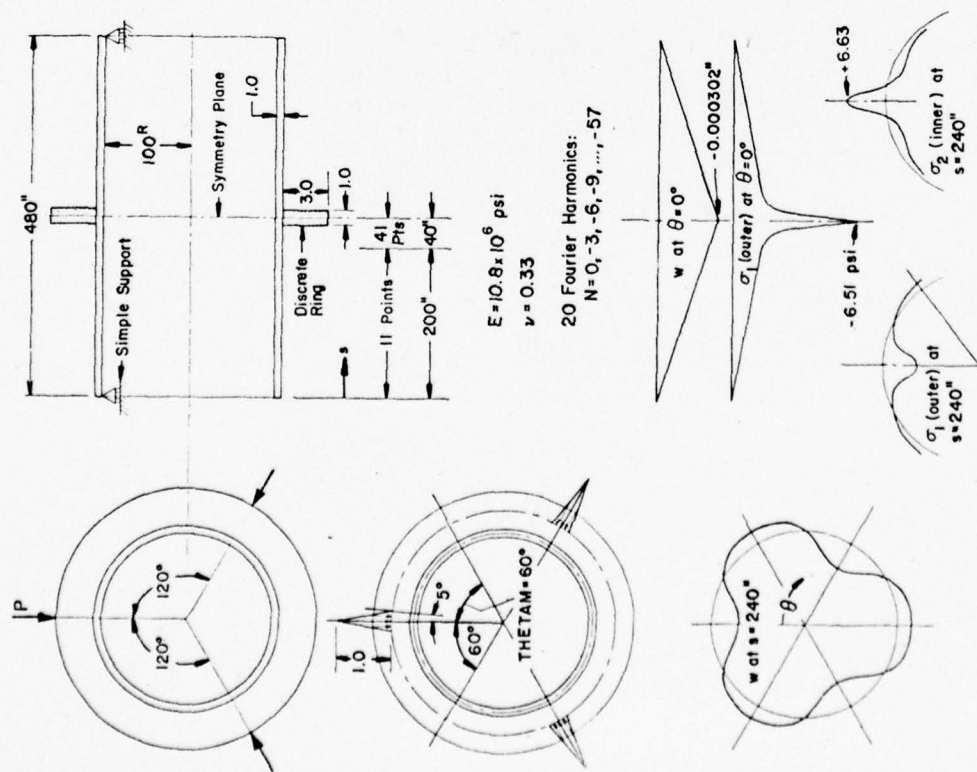

Fig. A12 Cylinder with three point loads (INDIC = 3)

Example of Cylinder with Three Point Loads

```

CYL, WITH THREE POINT LOADS (INDIC=3) TITLE
3, 2, 0, 1, 0 INDIC, NPRT, NLAST, ISTRS, IPRE
1, 2, 0, 0 NSEG, NCOND, IBOUND, IRIGID
0, -57, -3 NSTART, NFIN, INCR
0, 0, 0, 0, 0 NOB, NMINB, NMAXB, INCRB, NVEC
5, 5, 31 NDIST, NCIRC, NTHETA
1011, 1026, 1043, 1049, 1052 (ITHETA(I), I = 1, NCIRC)
0., 10., 20., 35., 60. ( THETA(I), I = 1, NDIST)
60., 0., 0. THETAM, THETAS, 0.
1, 1, 1, 1, 0, 1, 0, 0, 0. IS1, IP1, IS2, IP2, IU*, IV, IW*, IX, DI, D2
1, 52, 1, 52, 1, 0, 0, 1, 0., 0. IS1, IP1, IS2, IP2, IU*, IV, IW*, IX, DI, D2
0., 0., 0., 0., 0. P, DP, TEMP, DTEMP
0., 0., 0., 0. FSTART, FMAX, DF
52, 1, 0 NMESS, NTYPEH, 0 .....Segment #1
4 NIVALU
1, 10, 11, 51 (HVALU(I), I = 1, NIVALU)
1., 1., .05, .05 ( HVALU(I), I = 1, NIVALU)
1, 3, 0 NSHAPE, NTYPEZ, IMP
100.5, 0., 100.5, 240. R1, Z1, R2, Z2
ZVAL
1 NRRINGS
2 NTYPE
240.0 Z(1)
1 NTYPEP(1)
5400000., 3., 2.25, .25, 0., 2., E, A, RIV, RIX, RIXY, EI,
0., 1639000., 0. E2, GJ, RM
1 LINTYP
4 NTYPEL
0, 0, 1, 0 (NLOAD(M), M = 1, 4)
1.0 H(1)
3, 2, 1 NTHETA, NOPT, NODD
0., 5., 60. (THETA(J), J = 1, NTHETA)
-1., 0., 0. (YPLUS(J), J = 1, NTHETA)
0, 0, 0, 0 NLTYPE, NPSTAT, NTSTAT, NTGRAD
2 NVALL
10800000., .33, 0., 0., 0., 0. E, U, SM, ALPHA, ANRS, SUR
    
```

Note: Since there are three point loads applied at 120 degree intervals around the circumference, it is necessary only to expand the circumferential variation in the interval $-\text{THETAM} \leq \theta \leq \text{THETAM} = -60. \leq \theta \leq +60.$ and to set $\text{INCR} = -3$, since only every third harmonic contributes to the load function. If there are m equally spaced loads around the circumference one can expand in the interval $-(180/m) \leq \theta \leq + (180/m)$ and set $\text{INCR} = -m$ or $+m$, depending on whether the function is even $(-m)$ or odd $(+m)$ about $\theta = 0$.

Another note: For discrete rings at symmetry planes: cut the modulus E and the torsional rigidity GJ and the density RM in half and leave all other variables alone.

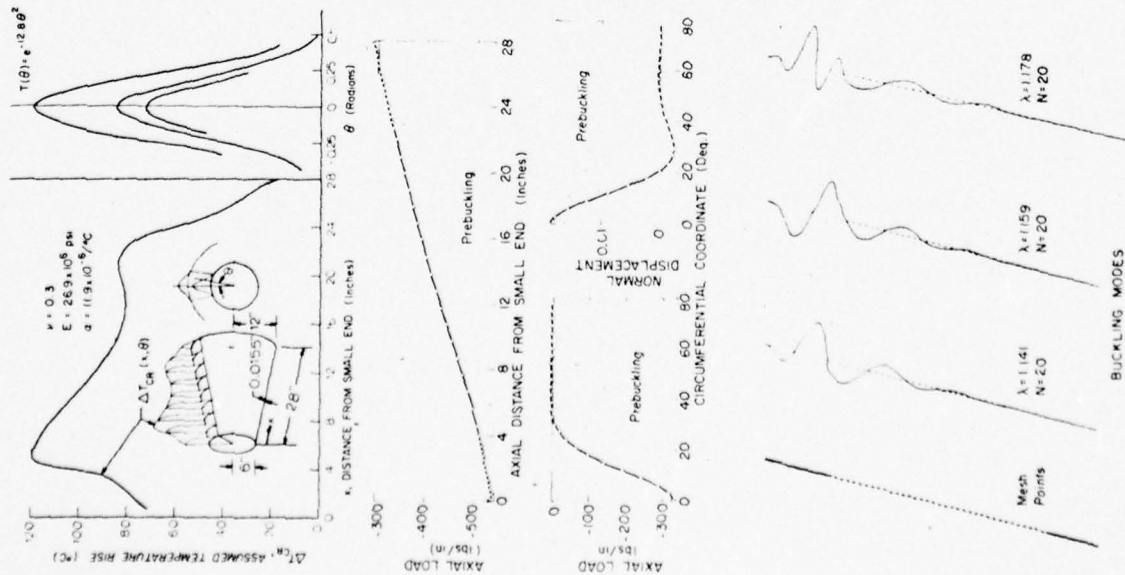

Fig. A13 Buckling of cone heated on an axial strip (INDIC = 4)

Example of the Buckling of a Cone Heated on an Axial Strip

```

BUCKLING OF CONE HEATED ON AXIAL STRIP (INDIC=4)  TITLE
4, 2, 0, 0, 1  INDIC, NPRI, NLAST, ISTRS, IPRE
1, 2, 0, 0  NSEG, NCOND, IBOUND, IIRIGID
0, -19, -1  NSTART, NFIN, INCR
20, 20, 20, 1, 3  NOB, NMINB, NMAXB, INCRB, NVEC
1, 1, 61  NDIST, NCIRC, NTHETA
1066  ( THETA(1), I = 1, NDIST)
0.  THETAM, THETAS, 0.
180., 0., 0.  ISI, IPI, IS2, IP2, IU*, IV, IW*, IX, DI, D2
1, 1, 1, 1, 1, 1, 1, 1, 1, 0., 0.  ISI, IPI, IS2, IP2, IU*, IV, IW*, IX, DI, D2
1, 97, 1, 97, 1, 1, 1, 1, 1, 0., 0.  P, DP, TEMP, DTEMP
0., 0., 0., 0.  FSTART, FMAX, DF
97, 1, 0  NMESH, NTYPEH, INIVAL
6  NHVALU
1, 28, 29, 64, 65, 96  (HVALU(I) I = 1, NHVALU)
.143, .143, .5, .5, .167, .167  ( HVALU(I) I = 1, NHVALU)
1, 3, 0  NSHAPE, NTYPEZ, IMP
6., 0., 12., 27.35  R1, Z1, R2, Z2
.00775  ZVAL
0  NRRINGS
0  LINTYP
2, 0, 18, 1  NLTYPE, NPSTAT, NTSTAT, NTGRAD
4  NTYPEL
1, 0, 0  NLOAD(1), NLOAD(2), NLOAD(3)
68., 80., 85., 90., 105, 119.5,  NLOAD(1), NLOAD(2), NLOAD(3)
118., 112., 93.5, 82., 81.4, 83.5,  (T(I), I = 1, NTSTAT)
84.2, 82., 75.5, 50., 35., 20.
20, 3, 1  NTHETA, NOPT, NODD
0., 1.72, 3.44, 5.16, 6.88, 8.59,  NTHETA, NOPT, NODD
10.3, 12.0, 13.8, 15.5, 17.2,  (TETHA(J), J = 1, NTHETA)
20.6, 24.1, 27.5, 30.9, 34.4,
37.8, 41.3, 51.6, 180.
2  NTYPE
0., 1.95, 2.93, 3.42, 3.91, 4.88,  (Z(I), I = 1, NTSTAT)
5.86, 7.81, 11.7, 15.6, 17.6,
19.5, 20.5, 21.5, 22.5, 23.9,
25.4, 27.35
2  NWall
2690000., .3, 0., .0000119, 0., 0.  E, U, SM, ALPHA, ANRS, SUR
    
```

Note: NOPT = 3, which means that the circumferential variation of the temperature is determined by a user-written subroutine. In this case the user-written routine is:

```

SUBROUTINE GETY(NTHETA, THETA, YMINUS, YPLUS)
DIMENSION THETA(100), YMINUS(100), YPLUS(100)
DO 10 I = 1, NTHETA
YPLUS(I) = EXP(-12.8*THETA(I)**2)
YMINUS(I) = YPLUS(I)
RETURN
END
    
```

Note: The variable THETA () is in radians in this subroutine!

Example of Spherical Cap Buckling

SPHERICAL CAP BUCKLING (INDIC=-2)	TITLE
-2, 2, 0, 0, 0	INDIC, NPRT, NLAST, ISTRS, IPRE
1, 2, 0, 0	NSEG, NCOND, IBOUND, IRIGID
0, 0, 0, 0	NSTART, NFIN, INCR
2, 0, 10, 1, 1	NOB, NMINB, NMAXB, INCRB, NVEC
0, 0, 0	NDIST, NCIRC, NTHETA
0	(ITHETA(1), I = 1, NCIRC)
0	(THETA(1), I = 1, NDIST)
0	THETAM, THETAS, 0
1, 1, 1, 1, 0, 0, 0, 0, 0, 0	IS1, IP1, IS2, IP2, IU*, IV, IW*, IX, DI, D2
1, 20, 1, 20, 1, 1, 1, 1, 0, 0, 0	IS1, IP1, IS2, IP2, IU*, IV, IW*, IX, DI, D2
18, 4, 0, 0, 0	P, DP, TEMP, DTEMP
18, 50, 4	FSTART, FMAX, DF
20, 3, 0	NMESH, NTYPEF, 0,Segment #1
2, 3, 0	NSHAPE, NTYPEZ, IMP
0, 5.447, 104.4, 0, 0, 0, -994.6	R1, Z1, R2, Z2, RC, ZC
1.0	SROT
.5	ZVAL
0	NRINGS
0	LINTYP
1, 0, 0, 0	NLTYPE, NPSTAT, NISTAT, NTGRAD
1, 0, 0, 0, 0, 0, 0	P11, P12, P13, P14, P15
0, 0, 0, 0, 0, 0, 0	P21, P22, P23, P24, P25
2	NMALL
30000000, .3, 0, 0, 0, 0, 0, 0	E, U, SM, ALPHA, ANRS, SUR

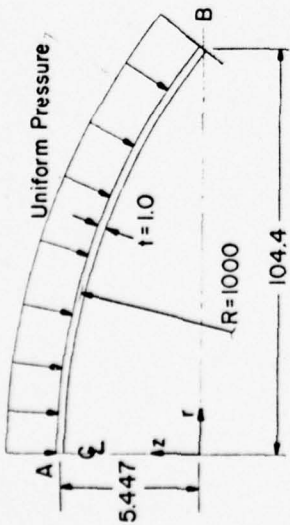

$E = 30 \times 10^6$ psi
 $\nu = 0.3$

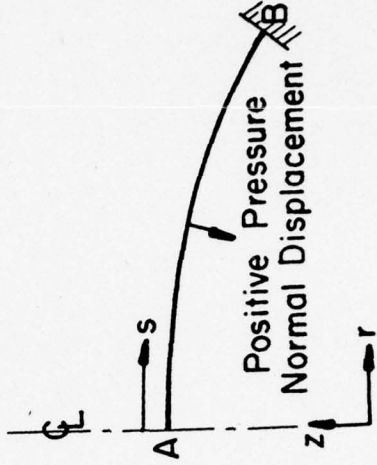
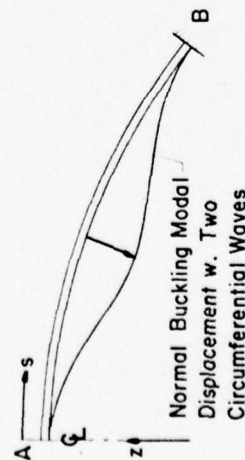
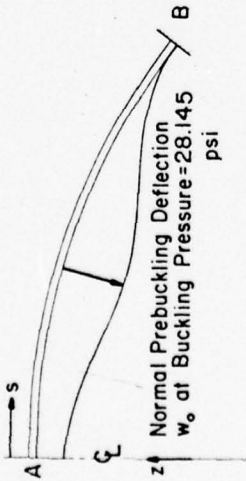

Fig. A14 Spherical cap buckling (INDIC = -2)

POSSIBLE PITFALLS AND RECOMMENDED SOLUTIONS

The following is a compilation of items which may cause the user of the BOSOR4 program some difficulty. Suggestions are given for overcoming the difficulties.

Provision of Consistent Input Data

In the initial use of a complex program such as BOSOR4 it is possible that the input data may not be consistent. The user is urged to check carefully the list and plot output for errors in the input data. In particular, boundary conditions, position of discrete ring stiffeners, meridian shape, line loads, and surface loads should be checked. Often the best way the user can familiarize himself with the input procedures is to run cases for which he knows the answers beforehand. A check of the mode shapes and stress distributions often reveals possible errors in input. It is emphasized that the user should check the sample cases in the BOSOR4 manual to see if they might help him to set up a new case.

Finding the Minimum Buckling Load:
Appropriate Choices for MOB, NMINE, NMAXB, INCRB

The theory on which BOSOR4 is based does not exclude the possibility that several values of circumferential wave number N may be associated with minimum buckling loads. One must always find the minimum minimum. This problem frequently arises in the calculation of buckling loads for complex shells or ring stiffened shells. A ring stiffened conical shell under external pressure is such a case (Fig. A15). Here there could be a minimum buckling load corresponding to general instability and additional minima (at higher values of N) corresponding to the local failure of each conical frustum (the bays between the rings). Physical intuition is invaluable as a guide for finding the absolute minimum load. One may idealize each bay of a ring stiffened shell by assuming that the bay is simply supported, calculate corresponding "panel" buckling loads with certain appropriate ranges of N , and then use the critical loads and values of N as starting points in an investigation of the assembled structure.

It is not necessary always to increase the circumferential wave number N by one. In the search for the minimum buckling load, for example, one may only be certain that the N corresponding to the minimum buckling load, N (critical), lies in the range $2 \leq N \leq 100$. One might, therefore, choose $\text{INCRB} = 10$ and "zero in" on a more accurate value in a subsequent run. The user should ordinarily set $\text{INCRB} = 0.05 * (\text{NMINE} + \text{NMAXB})$.

Experimental evidence is of course very useful in determining a good choice of MOB, NMINE, and NMAXB. If none is available the user is advised to try the following formulas:

- (1) "Square" buckles for short shells or panel buckling
 $N = \pi r/L$, where L is the shell meridional arc length between nodes of the buckling mode.
- (2) For monocoque deep shells, axial compression:
 $N = [(\text{Nominal circumferential rad. of curve})/t]^{1/2} (1 - \nu)^{1/2}$
- (3) For shallow spherical caps supported rigidly at their edges; external pressure:
 $N = 1.8 * \sigma_2 * (R/t)^{1/2} - 5$
- (4) For axially compressed conical shells and frustrums:
 Use formula 2 where the circumferential radius of curvature, R , is the average of the radii at the ends.
- (5) Spherical segments of any depth under axial tension
 $N = 1.8 * (R/t)^{1/2} \sin [\alpha_1 + 4.2 (t/R)]^{1/2}$
 where α_1 and α_2 are the meridional angles at the segment beginning and end, respectively.

The above list of formulas is by no means complete. However, notice that $(R/t)^{1/2}$ is a significant parameter. If N is known for a shell of a given geometry loaded in a certain way, a new value can be predicted for a new R/t through the knowledge that N often seems to vary as $(R/t)^{1/2}$. (R is the circumferential radius of curvature.)

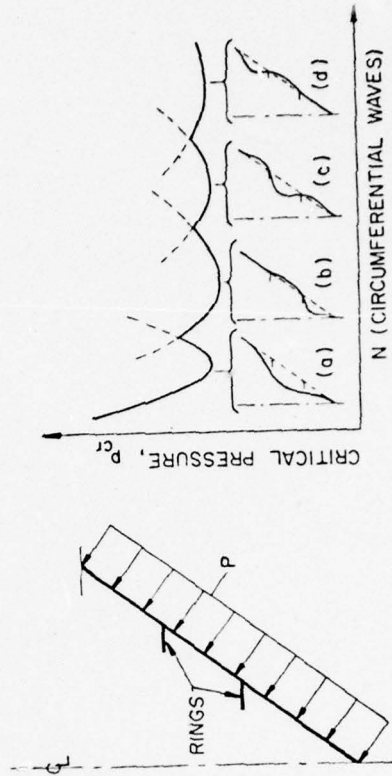

Fig. A15 Several buckling modes for ring stiffened conical shell
 (a) General instability (b) 1st bay buckling (c) 2nd bay buckling
 (d) 3rd bay buckling

Experience in the use of the program will lead to further competence in the selection of appropriate values for NOB, the initial guess at N. Again, the user must be sure that the input range $NIINB \leq N \leq NMAXB$ includes the minimum minimum buckling load.

Stress Resultant or Stress Discontinuities at Junctures and Boundaries

Stress resultants and stresses need not be continuous at segment junctures in all cases, of course. However, the user of BOSOR4 will notice that for some cases in which these quantities should be continuous there exist small discontinuities right at junctures. These discontinuities arise from the fact that the finite-difference energy method leads to larger truncation errors at boundaries than inside domains. If the user is particularly interested in stress at a juncture or boundary, it is urged that he concentrate mesh points in these areas to minimize truncation error. In any case, the BOSOR4 program is written so as to minimize the effect of boundary truncation error. The stress resultants are "corrected" as described on pages of 172 and 173 of [6]. In addition, "extra" mesh points are automatically inserted near the points on junctures and boundaries in order to make the truncation error as small as is feasible without encountering difficulties associated with precision round-off error. This feature is more completely described in the input data section.

Correct Modeling of Discrete Rings

It has been common in past analyses to neglect out-of-plane bending stiffness (terms involving I_x) which is called "RIX" in the manual and torsional stiffness (terms involving GJ) in the analysis of shells with discrete rings. The user is cautioned not to neglect these terms, in particular not to neglect the out-of-plane bending stiffness of the discrete rings (I_x). Such neglect may lead to very low estimates of the buckling loads, particularly in cases in which the ring is prestressed in compression and in which its centroid is located at several shell thicknesses away from the reference surface. Note also, that if the web of the ring is very thin in comparison with its length (height), the composite shell-ring structure may fail by crippling or "sidesway" of the web. These failure modes can be predicted by treatment of the webs as shell branches rather than as parts of the discrete rings, as described in previous sections. If a discrete ring occurs at a plane of symmetry, and this plane is used as a boundary in the analytical model, the user should set the ring modulus E, torsional rigidity GJ, and density ρ_m equal to 1/2 their actual values. All other quantities remain unchanged.

Also see the note given on the page where the discrete ring input is defined. This note has to do with the use of discrete rings to simulate a large mass.

Rigid Body Displacement

For $n = 0$ and $n = 1$ circumferential waves, rigid body motion is possible if the shell is not sufficiently constrained by the boundary conditions. The six possible rigid body modes, three translational and three rotational, can be prevented by choosing a meridional station at which to restrain the axial displacement u_x and the circumferential displacement v . The BOSOR4 manual describes an input variable, IRIGID, through which rigid body constraints are introduced in order to prevent $n = 0$ and $n = 1$ rigid body displacements. For $n > 1$ these constraints are automatically released and replaced by whatever the user has specified for IU^* , IV^* , IW^* , IX at the segment number and mesh point number corresponding to the meridional location at which the rigid body constraints have been applied. In this way rigid body displacements are prevented without introduction of spurious stresses.

Behavior at Apex of Shell

Certain regularity conditions exist at the apex of shells the meridians of which intersect the axis of revolution. These conditions have been satisfied to the extent which the finite difference model permits. Because of the "half-station" spacing of u and v , however, all of the regularity conditions are not satisfied exactly at the apex. This truncation error leads to errors in the local values of the stress resultants in the immediate neighborhood of the apex. The actual stress resultants at the apex can be obtained simply by extrapolating the solution from a region slightly away from the apex in which it is regular.

Buckling and Vibration of Structures with Planes of Symmetry

A fairly common oversight on the part of a program user is the failure to run a case in which buckling and vibration modes are sought which are antisymmetric with respect to a plane of symmetry. If half a shell or a part of a shell is being analyzed because of the existence of planes of symmetry, then the analyst should check for buckling and vibration both symmetrical and antisymmetrical with respect to the planes of symmetry. See the paragraph on "Correct Modeling of Discrete Rings" for how to model a discrete ring at a plane of symmetry.

Calculation of Same Eigenvalue Twice, Eigenvalues Out of Order

In problems for which the user requires more than about 5 eigenvalues for a given circumferential wave number N, the eigenvalue extraction routine occasionally computes the same eigenvalue and eigenvector more than once. It is also possible on occasion that eigenvalues will be calculated out of order or that an eigenvalue will be missed. Unfortunately, there is no way to make an eigenvalue finder based on

equations of the type used in the BOSOR4 program 100% reliable. The calculated eigenvalues are always eigenvalues of the system, but occasionally some eigenvalues may be repeated or missed. If it is suspected that an eigenvalue has been missed, it may help to run the case with a different number of mesh points, or to run the same case with a higher value of NVEC.

Multiple or Closely-Spaced Eigenvalues

In the case of ring stiffened shells it may turn out that eigenvalues corresponding to vibration frequencies or buckling loads are close together. This is particularly true of ring stiffened cylinders where the rings are equally spaced and rather stiff in bending compared to the shell bending stiffness. With such a configuration there are many modes in which the motion of the rings is of small amplitude compared to that of the shell. The bays between the rings vibrate at frequencies or buckle at loads which may approximate those corresponding to a simply-supported cylinder of the same geometry as the bay. Multiple or close-spaced eigenvalues correspond to modes in which one or more of the bays is vibrating or buckling while others are unaffected. True multiple eigenvalues are generally eliminated by use of symmetry and antisymmetry conditions at planes of symmetry in the shell. In eigenvalue problems the user should always analyze as small a segment of shell as possible in order to avoid numerical difficulties associated with multiple eigenvalues.

Block Sizes Too Large

On occasion the user will encounter the diagnostic "Block size of Segment No. exceeds maximum allowable"
 What is a block? In BOSOR4 the stiffness, mass, and load-geometric matrices are stored on disk or drum in blocks. The logic in the program is set up such that a given block must contain the information relevant to assembly of complete shell segments. The lowest possible number of segments per block is one, of course. Figure A16 shows a stiffness matrix configuration. Only the elements inside the "skyline" - the heavy line enclosing all non-zero elements below and including the main diagonal - are stored. The block size is equal to the number of little squares. In prebuckling problems the maximum block size is 2850; in stability, vibration, and non-symmetric stress problems the maximum block size is 3333. The program checks at the end of each segment to see if the elements corresponding to the next segment will cause the block to overflow. If they do, a new block is started.

It occasionally happens that the number of elements within the "skyline" corresponding to a single segment exceeds one or both of the allowable limits of 2850 or 3333. For example, referring to Figure A16, one can imagine that if the horizontal "skyscrapers" corresponding to the juncture conditions in segment 64 were very long, or if there were very many of them, the number of little squares within the skyline from Equation 30 to Equation 64 (Segment 2) might exceed the allowable limits. It is this situation that causes the message "Block size ... exceeds maximum allowable..." to be printed and the run to be aborted. The user can almost always find a way around this problem by reordering the segments or dividing up the segment with many branch conditions into more than one segment.

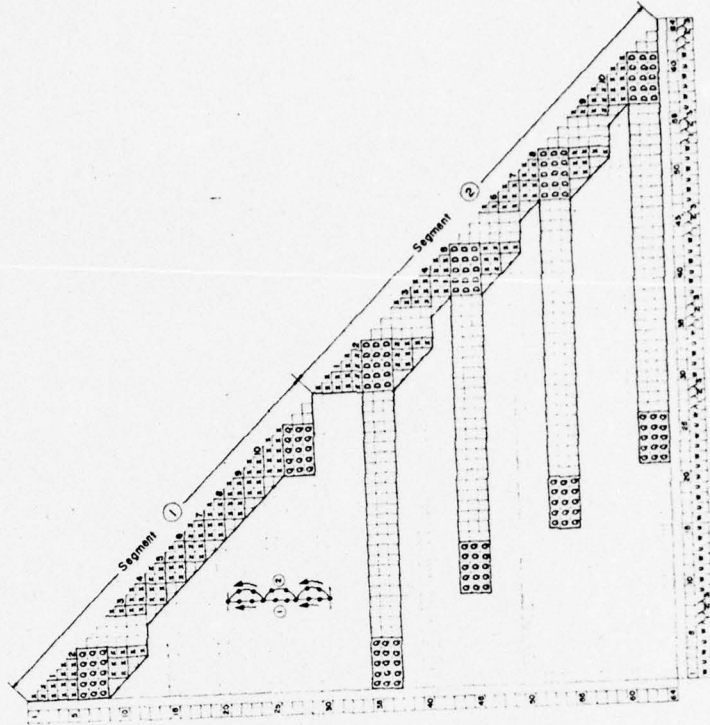

Fig. A16 Stiffness matrix configuration for double-walled shell fastened intermittently.

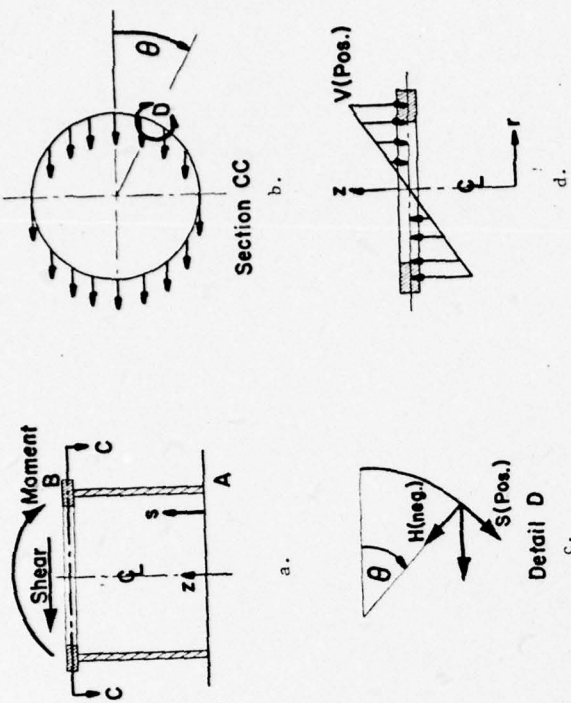

Fig. A17 Modeling global moments and shear forces

normal (H) and tangential (S) to the ring centroidal axis (c). The "global" moment M is modeled as an axial load which varies around the circumference as shown in (d). With the coordinate system shown it is clear that

$$V = V_0 \cos \theta, S = S_0 \sin \theta, H = H_0 \cos \theta$$

with V_0 and S_0 positive and H_0 negative. Referring to Table A2 we see that for this circumferential distribution of line loads we must use $n = -1$ as input to BOSOR4. (NSTART = NFIN = -1, INCR = 1 or -1)

Shear Line Loads, Concentrated or Otherwise

BOSOR4 users have had difficulty providing the correct input for shear line loads. This paragraph should help to clear up the trouble. Figure A18 shows an example of a ring with equal concentrated loads S applied at $\theta = 90^\circ$ and $\theta = 270^\circ$. In BOSOR4 concentrated

USERS' DOCUMENTATION

Moment Resultants and Reference Surface Location

More than one BOSOR4 user has indicated concern about the values obtained for the moment resultants M10, M20 or M1, M2. In this paragraph it is emphasized that these moment resultants are the values with respect to the reference surface, which may not necessarily be the middle surface. The magnitude of the moment resultants depends, therefore, on the location of the reference surface relative to the shell wall material. For example, in a uniformly loaded monocoque cylinder, if the inner or outer surface is used as the reference surface, the moments M1, M2 will approach the values

$$|M1| = |N1|t/2; \quad |M2| = |N2|t/2$$

far away from the edges. (t = thickness; $N1, N2$ = stress resultants) Note, however, that the extreme fiber stresses are of course not dependent on the location of the reference surface. In this connection please recall that the commonly used formula for extreme fiber stress

$$\sigma = \frac{N}{t} + \frac{6M}{t^2}$$

only applies if the shell is monocoque and if the middle surface is used as the reference surface.

Remarks on the Hemisphere Vibration

In this sample case the control integer IRIGID is set equal to unity. While this case does illustrate the proper mechanical use of the IRIGID $\neq 0$ option to prevent rigid body motion associated with $n = 0$ and $n = 1$ circumferential waves, the choice of a vibration analysis for the demonstration is a poor one, since the frequencies corresponding to $n = 0$ and $n = 1$ will depend upon the location of the constraints. The frequencies and modes will correspond to the actual free-free hemisphere vibrations only if the constraints are imposed such that the center of mass of the structures does not move during vibration in the $n = 0$ or $n = 1$ modes. Actually, in vibration analyses it is never necessary to set IRIGID $\neq 0$. To put it more clearly, IRIGID should be zero in vibration analyses. Note, however, that this case does illustrate the proper way to handle the problem of rigid body motion, which must be handled in stress and stability analyses.

Modeling Global Moments and Shear Forces

The user may wish to determine local stresses in a shell structure caused by certain known global moments and shear forces. Figure A17 shows one way in which the global forces might be converted into equivalent line loads. A cylinder with an end ring is loaded by a net shear force and moment (a). The shear force is assumed to act uniformly around the circumference as shown in (b). At every circumferential station θ , the shear force in (b) is resolved into components

stiffness matrix. The changes in meridional and hoop stress resultants N_{10} and N_{20} due to the load increments DP , $DV(\)$, etc., contribute terms to the so-called "load-geometric" matrix or "lambda-matrix." The critical loads are then

$$P_{cr} = (P + (\text{Eigenvalue}) * DF) * PDIST$$

$$V(\)_{cr} = V(\) + (\text{eigenvalue}) * DV(\); \text{ etc.},$$

where PDIST represents the meridional distribution of pressure. It is best, when doing an INDIC = 1 type of buckling analysis, to observe the following two rules:

1. Never have both non-zero initial load and non-zero increment for the same type of load.

EXAMPLE: $P = 0.0$, $DP = 1.0$ is O.K.

$P = 50.0$, $DP = 1.0$ is inadvisable, mainly because the user could easily err in interpreting the eigenvalue.

ANOTHER EXAMPLE: $P = 0.0$, $DP = -1.0$

$V(1) = 75.0$, $DV(1) = 0.0$ is O.K. because P and $V(1)$ are different kinds of loads.

2. Always choose loads that are small compared to the design load of the structure. In other words, choose magnitudes of the loads for which the prebuckling behavior really is linear. It is generally advisable to set $DP = -1.0$, for example, since the eigenvalue then represents the critical pressure directly. Remember that the actual pressure is $DP * f(s)$, where $f(s)$ is the meridional distribution. (In the examples it is tacitly assumed that $f(s) = 1.0$.)

Miscellaneous Suggestions

It is often advisable in buckling analyses to use $\text{INDIC} = 1$ with a rather wide range for N for the first run through the computer (linear buckling analysis). With this choice NVEC buckling loads are obtained for circumferential wavenumbers from $N = \text{NOB}$ to $N = \text{NMAXB}$ in steps of INCRB. The user can obtain multiple buckling loads at a given N only with $\text{INDIC} = 1$ and 4. Computer time is often saved in this manner, since the wavenumber corresponding to the minimum load is often not known a priori, even approximately. Also, there are cases for which two minima exist, and the user must find the absolute minimum. With

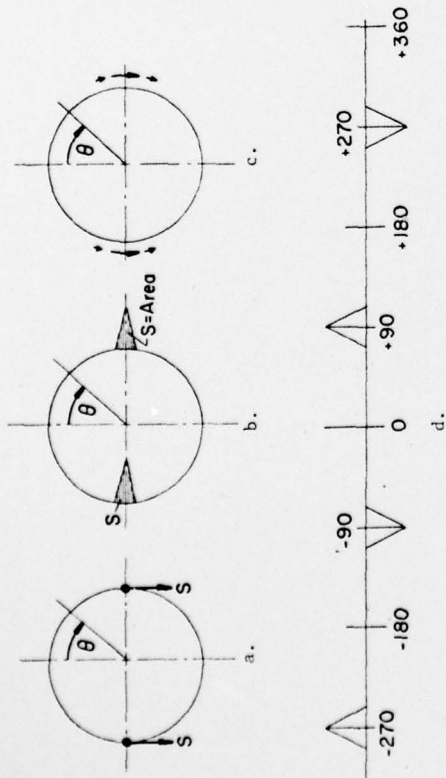

Fig. A18 Concentrated shear loads

loads are handled by spreading them out over a finite angle, say 5° or 10° , as shown in Fig. A18. The sign convention for shear loads is such that positive S is in the direction of increasing circumferential coordinate θ . Thus, if we plotted the triangular peaks shown in Fig. A18b on a rectilinear scale, we would obtain the odd function shown in Fig. A18d. It is emphasized that even though the shear loading is symmetrical about $\theta=0$, as seen from Fig. A18a, it is described by an odd function in the interval $-180^\circ < \theta < 180^\circ$. In this example, therefore, THETAM would be 180° , NODD would be 2, and the Fourier Harmonics -1 through -39 in steps of -2 would be used, since negative harmonics imply that the shear force varies as $\sin|N|\theta$. Also note that the entire range $-180^\circ < \theta < 180^\circ$ must be used, since the function repeats every 360° . If in Fig. A18a the S at 270° pointed upward, then the function would be even, THETAM would be 90° , and the Fourier harmonics would be +0, +2, +4, ..., +38.

Best Way to Run Cases with the $\text{INDIC} = 1$ Option

The BOSOR4 User's Manual says that with $\text{INDIC} = 1$ a linear buckling analysis is performed. Actually, this is not strictly so. With $\text{INDIC} = 1$ BOSOR4 performs a nonlinear prebuckling analysis for the "fixed" or "initial" loads, P , $V(\)$, etc., and then another non-linear prebuckling analysis for $P + DP$, $V(\) + DV(\)$, etc. The prestresses and shape change (meridional rotation distribution χ_0) corresponding to the initial loads P , $V(\)$, etc., modify the stability

INDIC = -1, only the relative minimum will be found unless more than one case is run, each case with its own range of N.

The capability of finding more than one buckling load at a given N is particularly useful to the designer who wishes to find the allowable buckling of a complex shell such as that shown in Fig. 1. The lowest buckling pressure might correspond to buckling of the cylinder, but at a few psi higher the ogive might buckle. Thus, the designer would not greatly improve the overall structure by strengthening just the cylinder. He must know the loads for which each of the segments buckles when these segments are analyzed as part of a larger structure.

In cases for which two eigenvalues are close together or for which bifurcation buckling loads are close to axisymmetric collapse loads, it is occasionally advisable to use INDIC = -2. In this way the first vanishing point of the stability determinant is approached gradually, and if axisymmetric collapse occurs at higher loads than nonsymmetric buckling, the stability determinant will change sign and the bifurcation buckling load will be determined.

With INDIC = 4, there are two possible flows of calculations:

If IPRE = 0 the prebuckling stress resultants N_{10} and N_{20} and the prebuckling meridional rotation X_0 are read in directly for a certain number, NSTRES, of meridional stations. Linear interpolation is performed internally for calculation of these prebuckling quantities at all of the mesh stations of each segment. Buckling loads (NVEC eigenvalues for each circumferential wave number N) are then calculated for the range NOB to NMAXB in steps of INCRB.

If IPRE ≠ 0 the prebuckling quantities are calculated from the linear theory for nonsymmetrically loaded shells, just as if INDIC were equal to 3. The user preselects the meridian (value of θ), called THETAS, which he feels represents the "worst" prestress from the point of view of stability. For example, a cylinder submitted to external pressure which varies around the circumference will generally buckle where the pressure has the highest amplitude. The BOSOR4 program will use the meridional stress distribution at $\theta = \text{THETAS}$ in the stability calculations. In the stability analysis the flow of calculations for both cases IPRE = 0 and IPRE ≠ 0 is the same as that for INDIC = 1.

BOSOR4 OUTPUT

Nomenclature of the BOSOR4 Output (Sample Units)

(Units do not have to be in in. and lb)

ALPHA1	angle from axis to beginning of spherical segment (degrees)
ALPHA2	angle from axis to end of spherical segment
ALPHAT	distance from axis to center of curvature of spherical segment
AREA	discrete ring cross-sectional area (in. ²)
BETA	meridional rotation, denoted X in analysis (radians)
CHIO	prebuckling rotation X_0 (radians)
CURL1	meridional curvature, $1/R_1$ (in. ⁻¹)
CURL2	normal circumferential curvature, $1/R_2$ (in. ⁻¹)
CURLD	s derivative of meridional curvature, $(1/R_1)$ (in. ⁻²)
DET	stability determinant "mantissa": Determinant = $\text{DET} * 10^{\text{NEX}}$
DH	eigenvalue radial line load or radial line load increment (lb/in.)
DM	eigenvalue meridional moment, or meridional moment increment (in.-lb/in.)
DP	eigenvalue pressure multiplier, or pressure increment multiplier (psi)
DTEMP	eigenvalue temperature rise multiplier, or temperature rise increment multiplier
DV	eigenvalue axial line load or axial line load increment (lbs/in.)
EIGENVALUE	Meaning depends upon case. (See following section)
ER	discrete ring modulus of elasticity (psi)
E1	discrete ring radial eccentricity (in.)
E2	discrete ring axial eccentricity (in.)
GJ	discrete ring torsional rigidity (lb-in. ²)
H	"fixed" or initial radial line load (lb/in.)
ITER	number of Newton-Raphson iterations for convergence of nonlinear axisymmetric stress analysis to within 0.1%
IX	discrete ring moment of inertia about x axis (in. ⁴)
IY	discrete ring moment of inertia about y axis (in. ⁴)
IXY	discrete ring product of inertia (in. ⁴)

M	"fixed" or initial meridional line moment (in.-lb/in.)
M10, M20	prestress or prebuckling meridional, circumferential moment resultants, (in.-lb/in.)
M1, M2, M1	linear stress analysis meridional, circumferential, twisting moment resultants, (in.-lb/in.)
N10, N20	prestress or prebuckling meridional, circumferential, resultants (lb/in.)
N	circumferential wave number
NEX	exponent for stability determinant (see DET)
P	pressure multiplier (psi)
PU, PV, PW	P_1, P_2, P_3 : meridional, circumferential, normal pressure components (psi) for given wave number N
PND	derivative of normal pressure with respect to arc length s
RAD	radius of parallel circle, r, (in.)
RADD	derivative of r with respect to arc length s (r')
RC	radius of discrete ring measured to centroid (in.)
RM	ring material mass density (lb-sec ² /in. ⁴)
S(K)	arc length to kth discrete ring (in.)
SHEAR	applied shear line load, (lb/in.)
SIGMA1(IN), S1(IN)	"inner" fiber on left side of increasing arc length. Outer fiber on right side.
SIGMA1(OUT), S1(OUT)	inner fiber meridional stress (psi)
SIGMA2(IN), S1(IN)	outer fiber meridional stress (psi)
SIGMA2(OUT), S2(OUT)	inner fiber circumferential stress (psi)
SIGMAE(IN), SVON(IN)	"effective" stress (psi)
SIGMAE(OUT), SVON(OUT)	outer fiber von Mises "effective" stress (psi)
TEMP	"fixed" or initial temperature rise multiplier
TMR	thermal line moment about x axis M_x^T



TMRX	thermal line moment about y axis M_y^T
TNR	thermal hoop force N_r^T
TN1, TN2	meridional, circumferential thermal stress resultants N_1^T, N_2^T
TM1, TM2	meridional, circumferential thermal moment resultants M_1^T, M_2^T
U, UO	meridional displacement component (modal or linear stress analysis, prestress analysis) (in.)
UV, USTAR	axial displacement (u^*) for prestress analysis (in.)
V, VSTAR	circumferential displacement component v, v* in nonsymmetric analysis (in.)
V	"fixed" or initial axial line load (lb/in.)
W, WO	normal outward displacement component (modal or linear stress analysis, prestress analysis) (in.)
WSTAR	radial displacement w^*
Z	distance from shell leftmost surface to reference surface (in.)

Description of Output From Case 1:
Aluminum Frame Buckling (INDIC = 1)

Figure A8 shows the problem. The input data are listed on page 101. This case represents a general buckling and crippling analysis of a "T" shaped frame, and illustrates the phenomenon of more than one minimum in the "plot" of buckling load vs. circumferential wave number.

The frame is treated as a branched "shell" of three segments, the geometry of which is given (with constraint conditions) on the first three pages of output. The user will notice that each segment has two mesh points more than the number provided as input.

Two additional w points are "inserted" automatically between the first and second and last and second-to-last points in each segment. This measure is taken in order to reduce the truncation errors associated with boundaries and to prevent spurious modes associated with the fictitious points. If h is the original mesh spacing at the edges, the "extra" w points are located at $h/20$ in from the edges. It is emphasized that the user does not need to consider these extra points in making up a case. All quantities are automatically "shifted" to account for the internal change.

It is important to point out that the "stations" and "arc lengths" printed out on page 2 of the output refer to the points at which the energy density E is evaluated and not in general to the w mesh points. Each "energy point" is located half way between adjacent u points. As seen from the sketch below, if the mesh

spacing varies, as it does at the ends of each segment, the "energy points" do not coincide with the "w points" in regions of varying spacing.

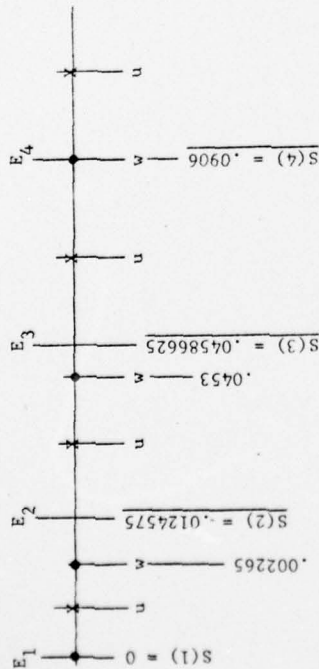

The positions of the first four stations, S(1) - S(4) in this case are shown in the above sketch. All of the output quantities correspond to the "energy stations" E1. In addition, discrete rings are assumed to be attached at the "energy stations," and not at the "w points." Branch locations also correspond to "energy points," and not to "w points."

Page 4 of the output gives data related to the constraint conditions. Two sets of data appear: those corresponding to the axisymmetric prestress problem, and those corresponding to the non-symmetric bifurcation buckling problem.

Pages 5 and 6 show the prestress distribution corresponding to the "fixed" or "initial" components of the loads, that is, corresponding to P and TEMP (and line loads V, H, and M, if such were present). Pages 6 and 7 show the "total" prestress state, that is the prestress quantities N10, N20, and X0 which correspond to loads P+DP and TEMP+DTEMP (also V+DV, H+DH, M+DM, if such were present). The prestress distributions corresponding to the predicted buckling loads λ are given by:

$$N_{10_{cr}} = \left(N_{10_{tot}} - N_{10_{fixed}} \right) \lambda + N_{10_{fixed}}$$

$$N_{20_{cr}} = \left(N_{20_{tot}} - N_{20_{fixed}} \right) \lambda + N_{20_{fixed}}$$

$$X_{0_{cr}} = \left(X_{0_{tot}} - X_{0_{fixed}} \right) \lambda + X_{0_{fixed}}$$

in which subscript "fixed" denotes the quantities listed on pages 5 and 6 and "tot" denotes the quantities listed on output pages 6 and 7. The output on page 7 has to do with calculation of the matrices K1 and K2 which is done in the overlay ARRAYS and calculation of the lowest eigenvalue, which is done in the overlay BUCKLE. All of these calculations correspond to two circumferential waves. The line "9 NEGATIVE ROOTS FOR SHIFT, AXT = 0.00" may help the user to determine if any eigenvalues (roots) have been missed. In this case there are nine negative roots for zero shift because there are nine Lagrange multipliers associated with the nine "non-zero" constraint conditions (see integers listed under USTAR VSTAR WSTAR BETA on page 1). The quantity of negative roots for zero shift should always be equal to the quantity of "ones" listed under USTAR VSTAR WSTAR BETA for the stability and vibration and nonsymmetric stress constraint conditions. If several eigenvalues are to be calculated for each wave-number N, and if the user discovers that a root has been skipped, the lines "9 negative roots ..." can be used with the shifts, AXT to bracket the missing roots, if any. The statement "THERE ARE 1 EIGENVALUES BETWEEN .000 AND .4255236+03" will tell the user if all of the roots in a given load range have been found. This number of roots should equal the input value, NVEC.

The buckling eigenvalues λ and mode shapes for N = 2, 6, 10 and 14 waves are given on pages 8 to 14. The user can see that N = 2 corresponds to overall "ovalization" of the ring with virtually no distortion of the ring cross section. The buckling load q for this type of deformation is approximately

$$L_1 \lambda = q = EI(N^2 - 1)/r_c^3$$

in which L1 is the length of the first segment (L1 = .453 in Fig. A1) over which the uniform pressure is applied. The buckling loads for higher values of N correspond to crippling of the web (Segment 2).

START READING DATA FOR THIS CASE
ELAPSED TIME = 01 01 01 15

1

130

ADD,P DB#B4TESTDATA.

BEGINNING OF NEXT CASE

ALUMINUM FRAME BUCKLING (INDIC # 1)

STABILITY ANALYSIS WITH LINEAR BENDING PREBUCKLING
ANALYSIS, BUCKLING LOADS CALCULATED FOR NO,LT,N,LY,NM
AX.

ANALYSIS TYPE = 1; PRINT OPTION = 1; PLOT OPTION = 0; STRESS OPTION = 0; PRESTRESS CALCULATION OPTION = 1

NUMBER OF SHELL SEGMENTS = 3

STRESS CALCULATED FOR CIRCUMFERENTIAL WAVES FROM 0 TO 0 IN INCREMENTS OF 1

INITIAL BUCKLING OR VIBRATION WAVE NO, # 2; MINIMUM WAVE NO, # 2; MAXIMUM WAVE NO, # 10; INCREMENTS # 1

EIGENVALUES SOUGHT FOR EACH CIRCUMFERENTIAL WAVE NUMBER.

CONSTRAINT CONDITION DATA FOLLOW

SEG.	POINT CONNECTED TO	SEG.	POINT	USTAR	VSTAR	WSTAR	BETA	RADIAL DISC. D(1)	AXIAL DISC. D2(1)
1	1	1	1	1	0	0	0	0.00000000	0.00000000
1	6	2	1	1	1	1	1	0.00000000	0.00000000
2	10	3	4	1	1	1	1	0.00000000	0.00000000

PRESSURE MULTIPLIER P = 0.0000 ; INCREMENT DP = -1.0000+00; TEMPERATURE MULT,TEMP = 0.0000 ; INCREMENT DTEMP = 0.0000

2

INITIAL LOAD, FSTART = 0.0000 ; MAXIMUM LOAD, FMAX = -1.0000+00; STEP SIZE, DPM = -1.0000+00

SEGMENT NO. 1 IS A CYLINDER OR CONE.
END POINT COORDINATES (.5218+01, .0000) AND (.5218+01, .0530+00)
REFERENCE SURFACE GEOMETRY FOR SEGMENT NO. 1

STATION	ARC LENGTH	RAD	RADD	CUR1	CUR2	CUR3	Z
1	.00000000	.5218000+01	.00000000	.00000000	.19164831+00	.00000000	.00000000
2	.1245750+01	.5218000+01	.00000000	.00000000	.19164831+00	.00000000	.00000000
3	.4586624+01	.5218000+01	.00000000	.00000000	.19164831+00	.00000000	.00000000
4	.9654944+01	.5218000+01	.00000000	.00000000	.19164831+00	.00000000	.00000000
5	1.3590000+01	.5218000+01	.00000000	.00000000	.19164831+00	.00000000	.00000000
6	1.6120000+01	.5218000+01	.00000000	.00000000	.19164831+00	.00000000	.00000000
7	1.7265000+01	.5218000+01	.00000000	.00000000	.19164831+00	.00000000	.00000000
8	1.7180000+01	.5218000+01	.00000000	.00000000	.19164831+00	.00000000	.00000000
9	1.5171000+01	.5218000+01	.00000000	.00000000	.19164831+00	.00000000	.00000000
10	1.0230000+01	.5218000+01	.00000000	.00000000	.19164831+00	.00000000	.00000000
11	4.071332+00	.5218000+01	.00000000	.00000000	.19164831+00	.00000000	.00000000
12	4.405424+00	.5218000+01	.00000000	.00000000	.19164831+00	.00000000	.00000000
13	4.529994+00	.5218000+01	.00000000	.00000000	.19164831+00	.00000000	.00000000

PHYSICAL PROPERTIES OF SEGMENT NO. 1

ANALYSIS IS FOR A HOMOGENEOUS SHELL

MODULUS OF ELASTICITY = 1.0E+09; POISSON RATIO = .33300+00; SHELL DENSITY = .00000; THERMAL EXP COEF = .00000

MESH POINT STATION H/F, SURFACE THICKNESS

MESH POINT	STATION	H/F, SURFACE	THICKNESS
1	0.00000	0.00000	1.02000+01
2	1.24575+01	0.00000	1.02000+01
3	4.58662+01	0.00000	1.02000+01
4	9.65494+01	0.00000	1.02000+01
5	1.35900+01	0.00000	1.02000+01
6	1.61200+01	0.00000	1.02000+01
7	1.72650+01	0.00000	1.02000+01
8	1.71800+01	0.00000	1.02000+01
9	1.51710+01	0.00000	1.02000+01
10	1.02300+01	0.00000	1.02000+01
11	4.07133+00	0.00000	1.02000+01
12	4.40542+00	0.00000	1.02000+01
13	4.52999+00	0.00000	1.02000+01

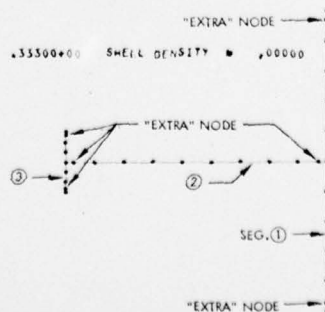

SEGMENT NO. 2 IS A CYLINDER OR CONE.

USERS' DOCUMENTATION

BOS/JR

131

END POINT COORDINATES (.5218+01, .0000) AND (.4882+01, .8900-01)
 REFERENCE SURFACE GEOMETRY FOR SEGMENT NO. 2

STATION	ARC LENGTH	RAD	RADD	CUR1	CUR2	CURID	Z
1	.4529999+00	.5218000+01	-.1000000+01	.00000000	.00000000	.00000000	.7500000+02
2	.4632000+00	.5217733+01	-.1000000+01	.00000000	.00000000	.00000000	.7500000+02
3	.4907999+00	.5180200+01	-.1000000+01	.00000000	.00000000	.00000000	.7500000+02
4	.5270000+00	.5143333+01	-.1000000+01	.00000000	.00000000	.00000000	.7500000+02
5	.5644999+00	.5100000+01	-.1000000+01	.00000000	.00000000	.00000000	.7500000+02
6	.6023333+00	.5060000+01	-.1000000+01	.00000000	.00000000	.00000000	.7500000+02
7	.6406667+00	.5031554+01	-.1000000+01	.00000000	.00000000	.00000000	.7500000+02
8	.6794999+00	.5014000+01	-.1000000+01	.00000000	.00000000	.00000000	.7500000+02
9	.7183333+00	.4995667+01	-.1000000+01	.00000000	.00000000	.00000000	.7500000+02
10	.7571667+00	.4974000+01	-.1000000+01	.00000000	.00000000	.00000000	.7500000+02
11	.7960000+00	.4949200+01	-.1000000+01	.00000000	.00000000	.00000000	.7500000+02
12	.8348333+00	.4922000+01	-.1000000+01	.00000000	.00000000	.00000000	.7500000+02

PHYSICAL PROPERTIES OF SEGMENT NO. 2

ANALYSIS IS FOR A MONOCOQUE SHELL
 MODULUS OF ELASTICITY = .10000+08 POISSON RATIO = .33300+00 SHELL DENSITY = .00000 THERMAL EXP COEF. = .00000

MESH POINT STATION REF. SURFACE THICKNESS

1	4.53000-01	7.50000-03	1.50000-02
2	4.63207-01	7.50000-03	1.50000-02
3	4.90700-01	7.50000-03	1.50000-02
4	5.27007-01	7.50000-03	1.50000-02
5	5.65000-01	7.50000-03	1.50000-02
6	6.02533-01	7.50000-03	1.50000-02
7	6.39007-01	7.50000-03	1.50000-02
8	6.77000-01	7.50000-03	1.50000-02
9	7.14333-01	7.50000-03	1.50000-02
10	7.51200-01	7.50000-03	1.50000-02
11	7.87733-01	7.50000-03	1.50000-02
12	7.89000-01	7.50000-03	1.50000-02

SEGMENT NO. 3 IS A CYLINDER OR CONE.
 END POINT COORDINATES (.4882+01, .0000) AND (.4882+01, .8900-01)
 REFERENCE SURFACE GEOMETRY FOR SEGMENT NO. 3

STATION	ARC LENGTH	RAD	RADD	CUR1	CUR2	CURID	Z
1	.7889999+00	.4882000+01	.00000000	.00000000	.2048340+00	.00000000	.1500000+01
2	.7930791+00	.4882000+01	.00000000	.00000000	.2048340+00	.00000000	.1500000+01
3	.8040108+00	.4882000+01	.00000000	.00000000	.2048340+00	.00000000	.1500000+01
4	.8180000+00	.4882000+01	.00000000	.00000000	.2048340+00	.00000000	.1500000+01
5	.8339999+00	.4882000+01	.00000000	.00000000	.2048340+00	.00000000	.1500000+01
6	.8483327+00	.4882000+01	.00000000	.00000000	.2048340+00	.00000000	.1500000+01
7	.8629811+00	.4882000+01	.00000000	.00000000	.2048340+00	.00000000	.1500000+01

PHYSICAL PROPERTIES OF SEGMENT NO. 3

ANALYSIS IS FOR A MONOCOQUE SHELL
 MODULUS OF ELASTICITY = .10800+08 POISSON RATIO = .33300+00 SHELL DENSITY = .00000 THERMAL EXP COEF. = .00000

AXISYMMETRIC PRESTRESS INPUT CONSTRAINT CONDITIONS FOLLOW

CONSTRAINT NO. 1 SEGMENT NO. 1 POINT 1 CONNECTED TO SEGMENT NO. 1 POINT 1...TYPE OF CONSTRAINT = 1
 CONSTRAINT NO. 2 SEGMENT NO. 1 POINT 7 CONNECTED TO SEGMENT NO. 2 POINT 1...TYPE OF CONSTRAINT = 4
 CONSTRAINT NO. 3 SEGMENT NO. 2 POINT 12 CONNECTED TO SEGMENT NO. 3 POINT 5...TYPE OF CONSTRAINT = 4

LOCAL MATRIX DIMENSION = 5 OVERLAP = 3 NO. CONSTRAINT CUNDS. PER CONSTRAINT POINT = 3 SYSTEM RANK = 86 NUMBER OF BLOCKS = 1

NUMBER OF EQUATIONS ASSOCIATED WITH SEGMENT NO. 1 EQUALS 32, NO. OF CONSTRAINT PTS. EQUALS 1
 NUMBER OF EQUATIONS ASSOCIATED WITH SEGMENT NO. 2 EQUALS 30, NO. OF CONSTRAINT PTS. EQUALS 1
 NUMBER OF EQUATIONS ASSOCIATED WITH SEGMENT NO. 3 EQUALS 24, NO. OF CONSTRAINT PTS. EQUALS 1
 BLOCK NUMBER = 1 LAST EQ. IN BLOCK = 86 LOWEST UNK IN BLOCK = 1, MAX. OFF-DIAGONAL WIDTH = 24

STABILITY, VIBRATION OR NON-SYMMETRIC STRESS INPUT CONSTRAINT CONDITIONS FOLLOW

CONSTRAINT NO. 1 SEGMENT NO. 1 POINT 1 CONNECTED TO SEGMENT NO. 1 POINT 1...TYPE OF CONSTRAINT = 1
 CONSTRAINT NO. 2 SEGMENT NO. 1 POINT 7 CONNECTED TO SEGMENT NO. 2 POINT 1...TYPE OF CONSTRAINT = 4
 CONSTRAINT NO. 3 SEGMENT NO. 2 POINT 12 CONNECTED TO SEGMENT NO. 3 POINT 5...TYPE OF CONSTRAINT = 4

LOCAL MATRIX DIMENSION = 7 OVERLAP = 4 NO. CONSTRAINT CUNDS. PER CONSTRAINT POINT = 4 SYSTEM RANK = 126 NUMBER OF BLOCKS = 1

NUMBER OF EQUATIONS ASSOCIATED WITH SEGMENT NO. 1 EQUALS 47, NO. OF CONSTRAINT PTS. EQUALS 1
 NUMBER OF EQUATIONS ASSOCIATED WITH SEGMENT NO. 2 EQUALS 46, NO. OF CONSTRAINT PTS. EQUALS 1
 NUMBER OF EQUATIONS ASSOCIATED WITH SEGMENT NO. 3 EQUALS 35, NO. OF CONSTRAINT PTS. EQUALS 1
 BLOCK NUMBER = 1 LAST EQ. IN BLOCK = 126 LOWEST UNK IN BLOCK = 1, MAX. OFF-DIAGONAL WIDTH = 35

DATA READ IN AND PROCESSED FOR THIS CASE, LEAVING SUBROUTINE READIT
 ELAPSED TIME = 01 OF 0.715

ENTERING SUBROUTINE PRE, AXISYMMETRIC PRESTRESS CALCULATOR

USERS' DOCUMENTATION

PRESSURE MULTIPLIER,P = 0.00000 TEMPERATURE MULTIPLIER,TEMP = 0.00000

FIXED PART OF AXISYMMETRIC PRESTRESS STATE, THESE QUANTITIES ARE NOT MULTIPLIED BY EIGENVALUE.

	PRESTRESS-- MERIDIONAL RESULTANT, N10	CIRCUMFERENTIAL RESULTANT, N20	MERIDIONAL ROTATION, CH10	FOR SEGMENT 1
1	0.00000000	0.00000000	0.00000000	0.00000000
2	0.00000000	0.00000000	0.00000000	0.00000000
3	0.00000000	0.00000000	0.00000000	0.00000000
4	0.00000000	0.00000000	0.00000000	0.00000000
5	0.00000000	0.00000000	0.00000000	0.00000000
6	0.00000000	0.00000000	0.00000000	0.00000000
7	0.00000000	0.00000000	0.00000000	0.00000000
8	0.00000000	0.00000000	0.00000000	0.00000000
9	0.00000000	0.00000000	0.00000000	0.00000000
10	0.00000000	0.00000000	0.00000000	0.00000000
11	0.00000000	0.00000000	0.00000000	0.00000000
12	0.00000000	0.00000000	0.00000000	0.00000000
13	0.00000000	0.00000000	0.00000000	0.00000000

FIXED PART OF AXISYMMETRIC PRESTRESS STATE, THESE QUANTITIES ARE NOT MULTIPLIED BY EIGENVALUE.

	PRESTRESS-- MERIDIONAL RESULTANT, N10	CIRCUMFERENTIAL RESULTANT, N20	MERIDIONAL ROTATION, CH10	FOR SEGMENT 2
1	0.00000000	0.00000000	0.00000000	0.00000000
2	0.00000000	0.00000000	0.00000000	0.00000000
3	0.00000000	0.00000000	0.00000000	0.00000000
4	0.00000000	0.00000000	0.00000000	0.00000000
5	0.00000000	0.00000000	0.00000000	0.00000000
6	0.00000000	0.00000000	0.00000000	0.00000000
7	0.00000000	0.00000000	0.00000000	0.00000000
8	0.00000000	0.00000000	0.00000000	0.00000000
9	0.00000000	0.00000000	0.00000000	0.00000000
10	0.00000000	0.00000000	0.00000000	0.00000000
11	0.00000000	0.00000000	0.00000000	0.00000000
12	0.00000000	0.00000000	0.00000000	0.00000000

FIXED PART OF AXISYMMETRIC PRESTRESS STATE, THESE QUANTITIES ARE NOT MULTIPLIED BY EIGENVALUE.

	PRESTRESS-- MERIDIONAL RESULTANT, N10	CIRCUMFERENTIAL RESULTANT, N20	MERIDIONAL ROTATION, CH10	FOR SEGMENT 3
1	0.00000000	0.00000000	0.00000000	0.00000000
2	0.00000000	0.00000000	0.00000000	0.00000000
3	0.00000000	0.00000000	0.00000000	0.00000000
4	0.00000000	0.00000000	0.00000000	0.00000000
5	0.00000000	0.00000000	0.00000000	0.00000000
6	0.00000000	0.00000000	0.00000000	0.00000000
7	0.00000000	0.00000000	0.00000000	0.00000000
8	0.00000000	0.00000000	0.00000000	0.00000000
9	0.00000000	0.00000000	0.00000000	0.00000000

ENTERING SUBROUTINE PRE, AXISYMMETRIC PRESTRESS CALCULATOR

PRESSURE MULTIPLIER,P = -1.00000000 TEMPERATURE MULTIPLIER,TEMP = 0.000000

TOTAL PRESTRESS STATE, THESE QUANTITIES MINUS CORRESPONDING FIXED QUANTITIES ARE MULTIPLIED BY EIGENVALUE.

	PRESTRESS-- MERIDIONAL RESULTANT, N10	CIRCUMFERENTIAL RESULTANT, N20	MERIDIONAL ROTATION, CH10	FOR SEGMENT 1
1	-1.39609380E-09	0.74490732E+00	0.00000000	2.31552097E+08
2	0.11322575E-10	-0.74497777E+00	0.00000000	2.31177461E+08
3	0.75208067E-09	0.74451017E+00	0.00000000	2.24420094E+08
4	-1.18743028E-08	-0.74414045E+00	0.00000000	2.13327241E+08
5	0.40448352E-09	-0.74381195E+00	0.00000000	1.82287556E+08
6	-3.95912074E-09	0.74357527E+00	0.00000000	1.11591314E+08
7	1.32713467E-08	-0.74349940E+00	0.00000000	1.04813000E+08
8	-3.69249405E-09	0.74357527E+00	0.00000000	-1.82287527E+08
9	0.42378225E-09	-0.74349940E+00	0.00000000	-2.13327212E+08
10	-1.16015322E-08	0.74341404E+00	0.00000000	-2.24420094E+08
11	0.51927092E-09	-0.74451017E+00	0.00000000	-2.31177461E+08
12	0.31322575E-10	0.74497777E+00	0.00000000	-2.31552097E+08
13	-1.39609380E-09	0.74490732E+00	0.00000000	

TOTAL PRESTRESS STATE, THESE QUANTITIES MINUS CORRESPONDING FIXED QUANTITIES ARE MULTIPLIED BY EIGENVALUE.

	PRESTRESS-- MERIDIONAL RESULTANT, N10	CIRCUMFERENTIAL RESULTANT, N20	MERIDIONAL ROTATION, CH10	FOR SEGMENT 2
1	-3.39677376E-02	0.02249800E+01	0.00000000	1.46813090E+15
2	-3.32408093E-02	-0.02249800E+01	0.00000000	1.46813090E+15
3	-3.12602800E-02	0.04499600E+01	0.00000000	1.46813090E+15

USERS' DOCUMENTATION

4	-2.8500360-02	-4.0763720-01	-3.30813845-15
5	-2.5703301-02	-4.10418913-01	-5.71058030-15
6	-2.29549274-02	-4.13262319-01	-8.14254413-15
7	-2.04979981-02	-4.16169249-01	-1.05070139-14
8	-1.70756290-02	-4.19141417-01	-1.30501908-14
9	-1.40350452-02	-4.22141405-01	-1.55324944-14
10	-1.09000383-02	-4.25251208-01	-1.80020444-14
11	-0.63001309-03	-4.27387230-01	-2.09500043-14
12	-7.74878022-03	-4.28460430-01	-2.05337047-14

TOTAL PRESTRESS STATI. THESE QUANTITIES MINUS CORRESPONDING FIXED QUANTITIES ARE MULTIPLIED BY EIGENVALUE,

PRESTRESS= MERIDIONAL RESULTANT, N10 CIRCUMFERENTIAL RESULTANT, N20 MERIDIONAL ROTATION, CW10 FOR SEGMENT 3

1	-2.29192007-07	-4.2440001-01	-3.65000458-07
2	-6.91215973-11	-4.25400161-01	-2.027222217-07
3	-4.6202330-10	-4.25031810-01	-3.51055054-07
4	9.24040617-10	-4.25794225-01	-2.00292094-07
5	-1.02591002-09	-4.25800037-01	-2.05537051-07
6	4.74006017-10	-4.25794225-01	2.00292094-07
7	-4.32419470-10	-4.25031810-01	3.07002174-07
8	-6.91215973-11	-4.25400161-01	3.65990395-07
9	-2.29192007-07	-4.2440001-01	

ENTER SUBROUTINE ARRAYS TO CALCULATE STIFFNESS MATRIX, LOAD=GEOMETRIC MATRIX+L+2 MATRIX, OR MASS MATRIX, 2 WAVES

ENTER FRAND2 TO CALCULATE LOWEST 1 EIGENVALUES, NAVEUMBER=NB 2 WAVES

0 NEGATIVE ROOTS FOR SHIFT, AXI = 0.00000

ITERATIONS HAVE CONVERGED FOR EIGENVALUE NO. 1 BUCKLING LOAD FACTOR= 4.25390+02, 2 CIRCUMFERENTIAL WAVES
ELAPSED TIME = 01 01 2.930

10 NEGATIVE ROOTS FOR SHIFT, AXI = -4.2552+02

THERE ARE 1 EIGENVALUES BETWEEN .0000000 AND .4255236+03

BUCKLING LOADS AND MODES FOLLOW

CIRCUMFERENTIAL WAVE NUMBL: N = 2

EIGENVALUES = 4.25390+02

MODE SHAPE FOR EIGENVALUE NO. 1 FOLLOWS

BUCKLING MODE FOR SEGMENT 1

POINT	STATION	U	V	W
1	0.000	1.213-21	5.190-01	1.000+00
2	1.240+02	2.980-05	5.190-01	4.409-01
3	4.587+02	1.097-04	5.190-01	0.907-01
4	9.000+02	2.191-04	5.189-01	0.904-01
5	1.359-01	3.222-04	5.189-01	0.902-01
6	1.812-01	4.254-04	5.189-01	0.901-01
7	2.265-01	5.248-04	5.188-01	0.901-01
8	2.718-01	6.241-04	5.189-01	0.901-01
9	3.171-01	7.274-04	5.189-01	0.902-01
10	3.624-01	8.335-04	5.189-01	0.903-01
11	4.077-01	9.396-04	5.189-01	0.906-01
12	4.405-01	1.019-03	5.189-01	0.908-01
13	4.530-01	1.044-03	5.189-01	0.909-01

BUCKLING MODE FOR SEGMENT 2

POINT	STATION	U	V	W
1	4.530+01	-0.991-01	5.188+01	5.248+04
2	4.035+01	-0.991-01	5.210+01	4.230+04
3	4.008+01	-0.990-01	5.201+01	5.100+04
4	5.277+01	-0.984+01	5.391+01	5.043+04
5	5.050+01	-0.984+01	5.093+01	4.937+04
6	6.023+01	-0.980+01	5.595+01	4.859+04
7	6.397+01	-0.983+01	5.907+01	4.719+04
8	6.770+01	-0.980+01	5.790+01	4.607+04
9	7.103+01	-0.976+01	5.982+01	4.405+04
10	7.512+01	-0.972+01	6.004+01	4.303+04
11	7.787+01	-0.968+01	6.080+01	4.300+04
12	7.890+01	-0.967+01	6.109+01	4.269+04

BUCKLING MODE FOR SEGMENT 3

POINT	STATION	U	V	W
1	7.890+01	-2.065+04	6.109+01	0.940-01
2	7.531-01	-1.038+04	6.108+01	0.940-01
3	6.000+01	2.218+05	6.109+01	0.948-01
4	8.107+01	2.303+05	6.109+01	0.947-01

ALUMINUM FRAME BUCKLING (INDIC = 1)
DEFORMED STRUCTURE
BUCK. MODE 1. N= 2. LOAD= 4.254+02

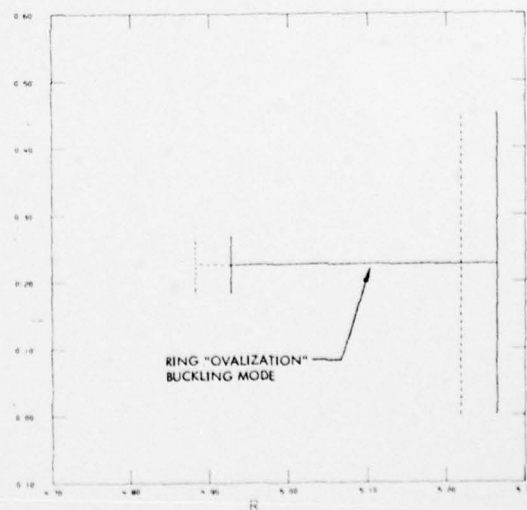

```

5  R.335+01  4.200+00  0.100+01  9.967-01
6  P.483+01  0.194+00  0.100+01  9.967-01
7  R.030+01  0.115+00  0.100+01  9.968-01
8  R.739+01  9.975+00  0.100+01  9.969-01
9  R.700+01  1.000+03  0.100+01  9.969-01
      ELAPSED TIME = 01 01 3.324

```

ENTERING SUBROUTINE PLOT

WE ARE ENTERING S-H GEOPLOT TO PLOT THE UNDEFORMED STRUCTURE

WE ARE ENTERING S-H GEOPLOT TO PLOT THE DEFORMED STRUCTURE

ENTER SUBROUTINE HWAYS TO CALCULATE STIFFNESS MATRIX, LOAD-GEOMETRIC MATRIX, L*2 MATRIX, OR MASS MATRIX. 0 HAYS

ENTER FRANDZ TO CALCULATE LOWEST I EIGENVALUES. HAVENUMBER=N 0 HAYS

9 NEGATIVE ROOTS FOR SHIFT, AXT = 0.00000

9 NEGATIVE ROOTS FOR SHIFT, AXT = -2.11715+03

THERE ARE 9 EIGENVALUES RETAIN .0000000 AND .2117150+04

ITERATIONS HAVE CONVERGED FOR EIGENVALUE NO. 1, BUCKLING LOAD FACTOR = 2.13839+03 0 CIRCUMFERENTIAL HAYS
ELAPSED TIME = 01 01 5.287

10 NEGATIVE ROOTS FOR SHIFT, AXT = -2.13900+03

THERE ARE 1 EIGENVALUES RETAIN .0000000 AND .2139000+04

BUCKLING LOADS AND MODES FOLLOW

CIRCUMFERENTIAL WAVE NUMBER, N = 0

EIGENVALUES = 2.13839+03

MODE SHAPE FOR EIGENVALUE NO. 1 FOLLOWS

BUCKLING MODE FOR SEGMENT 1

POINT	STATION	U	V	W
1	0.000	2.504+23	-0.858+00	-4.435+03
2	1.240+02	4.121+06	-0.347+00	-4.180+03
3	4.587+02	1.774+05	-0.909+00	-3.517+03
4	9.980+02	0.133+05	-0.112+00	-2.010+03
5	1.395+01	7.231+05	-3.215+00	-1.044+03
6	1.812+01	1.187+04	-1.297+00	-7.533+04
7	2.205+01	1.359+04	0.180+00	1.870+04
8	2.718+01	1.270+04	2.560+00	1.150+03
9	3.171+01	1.050+04	4.490+00	2.100+03
10	3.624+01	9.030+05	0.405+00	3.017+03
11	4.071+01	8.312+05	0.270+00	3.940+03
12	4.405+01	9.107+05	0.000+00	4.027+03
13	4.530+01	0.213+05	1.019+03	4.984+03

BUCKLING MODE FOR SEGMENT 2

POINT	STATION	U	V	W
1	4.530+01	-1.470+00	0.140+05	1.349+04
2	4.033+01	-1.949+00	0.475+05	1.000+03
3	4.908+01	-1.905+00	0.405+05	2.042+02
4	5.277+01	-1.959+00	7.100+05	7.447+02
5	5.050+01	-1.952+00	7.800+05	1.582+01
6	6.023+01	-1.945+00	8.325+05	2.004+01
7	6.397+01	-1.917+00	8.800+05	3.945+01
8	6.770+01	-1.924+00	9.415+05	5.343+01
9	7.143+01	-1.920+00	1.000+04	0.847+01
10	7.512+01	-1.910+00	1.000+04	6.340+01
11	7.787+01	-1.902+00	1.112+04	9.400+01
12	7.800+01	-1.899+00	1.131+04	9.933+01

BUCKLING MODE FOR SEGMENT 3

POINT	STATION	U	V	W
1	7.800+01	9.920+01	5.212+02	-1.813+03
2	7.933+01	9.917+01	5.270+02	-1.645+01
3	8.040+01	9.920+01	3.851+02	-1.270+01
4	8.187+01	9.922+01	1.982+02	-0.165+02
5	8.335+01	9.923+01	1.131+04	1.060+04
6	8.483+01	9.922+01	1.920+02	0.183+02
7	8.632+01	9.920+01	-3.829+02	1.218+01
8	8.739+01	9.917+01	-5.257+02	1.048+01
9	8.780+01	9.910+01	-5.780+02	1.050+01

ELAPSED TIME = 01 01 5.000

ALUMINUM FRAME BUCKLING (INDIC 1) DEFORMED STRUCTURE BUCK. MODE 1, N=6, LOAD= 2.138+03

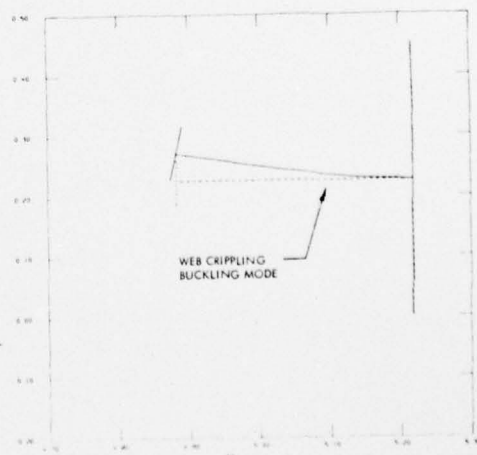

ENTERING SUBROUTINE PLOT
WE ARE ENTERING S-R DEPLY TO PLOT THE DEFORMED STRUCTURE

(11)

140

ENTER SUBROUTINE ARRAYS TO CALCULATE STIFFNESS MATRIX, LOAD-GEOMETRIC MATRIX, L*E*Z MATRIX, OR MASS MATRIX, 10 WAVES

ENTER BRAND2 TO CALCULATE LOWEST 1 EIGENVALUES. WAVE NUMBER = 10 WAVES

9 NEGATIVE ROOTS FOR SHIFT, AXI = 0.00000

9 NEGATIVE ROOTS FOR SHIFT, AXI = -1.65636+03

THERE ARE 0 EIGENVALUES BETWEEN .0000000 AND .165636+04

ITERATIONS HAVE CONVERGED FOR EIGENVALUE NO. 1 BUCKLING LOAD FACTOR = 1.67303+03 10 CIRCUMFERENTIAL WAVES
ELAPSED TIME = 01 01 7.367

10 NEGATIVE ROOTS FOR SHIFT, AXI = -1.67353+03

THERE ARE 1 EIGENVALUES BETWEEN .0000000 AND .167353+04

BUCKLING LOADS AND MODES FOLLOW

CIRCUMFERENTIAL WAVE NUMBER, N = 10

EIGENVALUES =

1.67303+03

CRITICAL (MINIMUM) LOAD

MODE SHAPE FOR EIGENVALUE NO. 1 FOLLOWS

USERS' DOCUMENTATION

BUCKLING MODE FOR SEGMENT 1

POINT	STATION	U	V	W
1	0.000	-1.117-03	-4.925-04	-1.940-03
2	1.260+02	7.433-06	-4.034-04	-1.350-03
3	4.587+02	3.232-05	-3.852-04	-1.370-03
4	9.086+02	7.129-05	-2.802-04	-9.942-04
5	1.359+01	1.191-04	-1.720-04	-6.074-04
6	1.812+01	1.762-04	-6.277-05	-2.762-04
7	2.265+01	2.150-04	4.951-05	1.150+04
8	2.718+01	2.117-04	1.828-04	5.150+04
9	3.171+01	1.904-04	2.753-04	9.028-04
10	3.624+01	1.707-04	3.800-04	1.261+03
11	4.071+01	1.765-04	4.971-04	1.051-03
12	4.519+01	1.790-04	5.270-04	1.927+03
13	4.950+01	1.822-04	6.169-04	2.011+03

BUCKLING MODE FOR SEGMENT 2

POINT	STATION	U	V	W
1	4.530+01	-1.150-04	4.951-05	2.149-04
2	4.033+01	-1.145-04	4.905-05	1.900-03
3	4.090+01	-1.133-04	5.010-05	2.300-02
4	5.277+01	-1.117-04	5.100-05	8.740-02
5	5.050+01	-1.102-04	5.210-05	1.125-01
6	6.023+01	-1.080-04	5.400-05	2.060-01
7	6.397+01	-1.075-04	5.622-05	4.170-01
8	6.770+01	-1.062-04	5.809-05	5.582-01
9	7.143+01	-1.048-04	6.215-05	7.090-01
10	7.512+01	-1.035-04	6.490-05	8.470-01
11	7.787+01	-1.025-04	6.920-05	9.500-01
12	7.890+01	-1.021-04	7.000-05	9.029-01

BUCKLING MODE FOR SEGMENT 3

POINT	STATION	U	V	W
1	7.890+01	9.915-01	9.573-02	-1.075-01
2	7.931+01	9.910-01	8.692-02	-1.522-01
3	8.040+01	9.920-01	6.334-02	-1.111-01
4	8.187+01	9.926-01	3.167-02	-5.507-02
5	8.335+01	9.929-01	7.000-05	1.021-04
6	8.483+01	9.928-01	-3.173-02	5.070-02
7	8.630+01	9.928-01	-6.320-02	1.113-01
8	8.778+01	9.910-01	-8.070-02	1.520-01
9	8.780+01	9.915-01	-9.550-02	1.027-01

ELAPSED TIME = 01 01 7.733

ENTERING SUBROUTINE PLOT

WE ARE ENTERING S-R DEPLY TO PLOT THE DEFORMED STRUCTURE

ALUMINUM FRAME BUCKLING UNDER 10 DEFORMED STRUCTURE
BUCK. MODE 1, N = 10, LOAD = 1.673-03

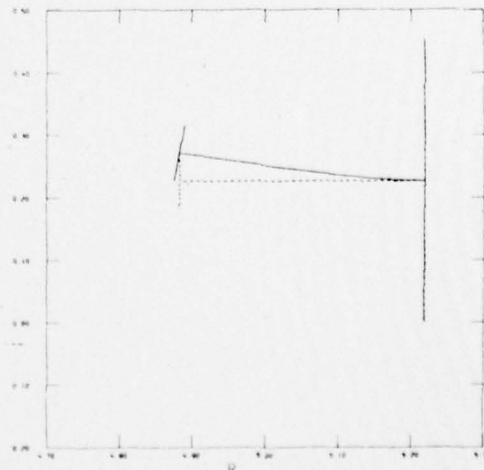

(12)

141

141

ENTER SUBROUTINE ARRAYS TO CALCULATE STIFFNESS MATRIX, LOAD-GEOMETRIC MATRIX, LOAD MATRIX, OR MASS MATRIX, 14 WAVES

13

142

ENTER BRAND2 TO CALCULATE LOWEST 1 EIGENVALUES. NAVE NUMBER, NB 14 WAVES

9 NEGATIVE ROOTS FOR SHIFT, AXI = 0.00000

ITERATIONS HAVE CONVERGED FOR EIGENVALUE NO. 1 BUCKLING LOAD FACTOR = 1.03714+03 14 CIRCUMFERENTIAL WAVES
ELAPSED TIME = 01 01 9.90

10 NEGATIVE ROOTS FOR SHIFT, AXI = -1.83709+03

THERE ARE 1 EIGENVALUES BETWEEN .0000000 AND .1837093+00

BUCKLING LOADS AND MODES FOLLOW

CIRCUMFERENTIAL WAVE NUMBER, N = 14

EIGENVALUES = 1.03714+03

MODE SHAPE FOR EIGENVALUE NO. 1 FOLLOWS

BUCKLING MODE FOR SEGMENT 1

POINT	STATION	U	V	W
1	0.000	1.158-23	-2.678-04	-8.150-04
2	1.240+02	1.500-05	-2.518-04	-7.810-04
3	4.587+02	5.799-05	-2.084-04	-6.851-04
4	9.060+02	1.214-04	-1.480-04	-5.360-04
5	1.355+01	1.904-04	-8.483-05	-3.513-04
6	1.812+01	2.778-04	-1.603-05	-1.413-04
7	2.265+01	3.365-04	5.687-05	1.028-04
8	2.718+01	3.343-04	1.322-04	3.066-04

9	3.171+01	3.277-04	2.221-04	5.464-04
10	3.624+01	2.710-04	2.783-04	8.242-04
11	4.071+01	2.170-04	3.491-04	1.162+03
12	4.505+01	1.733-04	4.024-04	1.215+03
13	4.930+01	1.297-04	4.225-04	1.277+03

BUCKLING MODE FOR SEGMENT 2

POINT	STATION	U	V	W
1	4.530+01	-1.004-05	5.687-05	5.365-04
2	4.633+01	-1.237-04	5.602-05	2.432+03
3	4.909+01	-1.217-04	5.399-05	2.705+02
4	4.277+01	-9.100-05	5.164-05	9.784+02
5	4.650+01	-6.171-05	4.990-05	2.055+01
6	4.625+01	-4.211-05	4.900-05	5.257+01
7	4.547+01	-4.481-05	4.884-05	4.629+01
8	4.770+01	-4.776-05	4.951-05	6.037+01
9	4.143+01	-4.488-05	5.110-05	7.419+01
10	4.511+01	-4.412-05	5.284-05	8.789+01
11	4.787+01	-4.283-05	5.650-05	9.615+01
12	4.890+01	-4.235-05	5.700-05	9.401+01

BUCKLING MODE FOR SEGMENT 3

POINT	STATION	U	V	W
1	7.890+01	9.910-01	1.321-01	-1.301-01
2	7.931+01	9.401-01	1.199-01	-1.269-01
3	8.000+01	9.451-01	8.725-02	-9.274+02
4	8.187+01	9.934-01	4.384-02	-8.605+02
5	8.135+01	9.491-01	5.768-05	8.225-04
6	8.084+01	9.034-01	-4.372-02	4.602-02
7	8.030+01	9.931-01	-8.714-02	9.240+02
8	8.759+01	9.421-01	-2.197-01	1.265-01
9	8.780+01	9.416-01	-1.320-01	1.392-01

ELAPSED TIME = 01 01 9.509

ENTERING SUBROUTINE PLOT

WE ARE ENTERING SUBROUTINE TO PLOT THE DEFORMED STRUCTURE

ELAPSED TIME = 01 01 9.762

START READING DATA FOR THIS CASE

ELAPSED TIME = 01 01 0.4

BEGINNING OF NEXT CASE

ALPHAS, GAMMA, BUCKLING LINEIC 14
DEFORMED STRUCTURE
EIGEN. MODE 1, N= 14, LOAD= 1.037+03

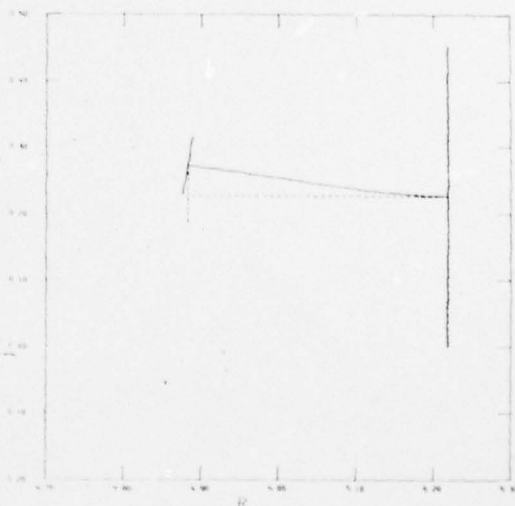

USERS' DOCUMENTATION

14

143

143

UNCLASSIFIED

SECURITY CLASSIFICATION OF THIS PAGE (When Data Entered)

REPORT DOCUMENTATION PAGE		READ INSTRUCTIONS BEFORE COMPLETING FORM
1. REPORT NUMBER LMSC-D564369	2. GOVT ACCESSION NO.	3. RECIPIENT'S CATALOG NUMBER
4. TITLE (and Subtitle) HYBRID STRUCTURES OF REVOLUTION	5. TYPE OF REPORT & PERIOD COVERED Final (1/76-9/77)	
	6. PERFORMING ORG. REPORT NUMBER	
7. AUTHOR(s) David Bushnell	8. CONTRACT OR GRANT NUMBER(s) N00014-76-C-0692	
9. PERFORMING ORGANIZATION NAME AND ADDRESS Lockheed Palo Alto Research Laboratory 3251 Hanover Street Palo Alto, Calif.	10. PROGRAM ELEMENT, PROJECT, TASK AREA & WORK UNIT NUMBERS	
11. CONTROLLING OFFICE NAME AND ADDRESS Office of Naval Research	12. REPORT DATE September 1977	
	13. NUMBER OF PAGES	
14. MONITORING AGENCY NAME & ADDRESS (if different from Controlling Office)	15. SECURITY CLASS. (of this report) Unclassified	
	15a. DECLASSIFICATION/DOWNGRADING SCHEDULE	
16. DISTRIBUTION STATEMENT (of this Report) Distribution of this Document is Unlimited.		
17. DISTRIBUTION STATEMENT (of the abstract entered in Block 20, if different from Report)		
18. SUPPLEMENTARY NOTES		
19. KEY WORDS (Continue on reverse side if necessary and identify by block number) Shell, Solid, Stress, Buckling, Vibration, Nonlinear, Computer, Finite Element, Finite Difference, Eigenvalue		
20. ABSTRACT (Continue on reverse side if necessary and identify by block number) This report consists of two parts: 1. A brief description of the implemen- tation of a new equation solving and eigenvalue extraction package into BOSOR6 (a program for the analysis of hybrid structures of revolution) and 2. A new user's manual for BOSOR4, which has appeared as a chapter in STRUCTURAL MECHANICS SOFTWARE SERIES - VOL. 1, edited by Nicholas Perrone, Walter Pilkey, and Barbara Pilkey and published by the University Press of Virginia in 1977.		

DD FORM 1473 1 JAN 73

EDITION OF 1 NOV 65 IS OBSOLETE

UNCLASSIFIED

SECURITY CLASSIFICATION OF THIS PAGE (When Data Entered)

210 118