

AD-A048 306

TRANSPORTATION SYSTEMS CENTER CAMBRIDGE MASS  
CHARACTERIZATION OF CURRENT TOWER CAB ENVIRONMENTS. (U)  
NOV 77 V J HOBBS, D F CLAPP, P REMPFER  
TSC-FAA-77-19

F/G 13/3

UNCLASSIFIED

FAA-EM-77-10

NL

1 OF 3  
AD  
A048306

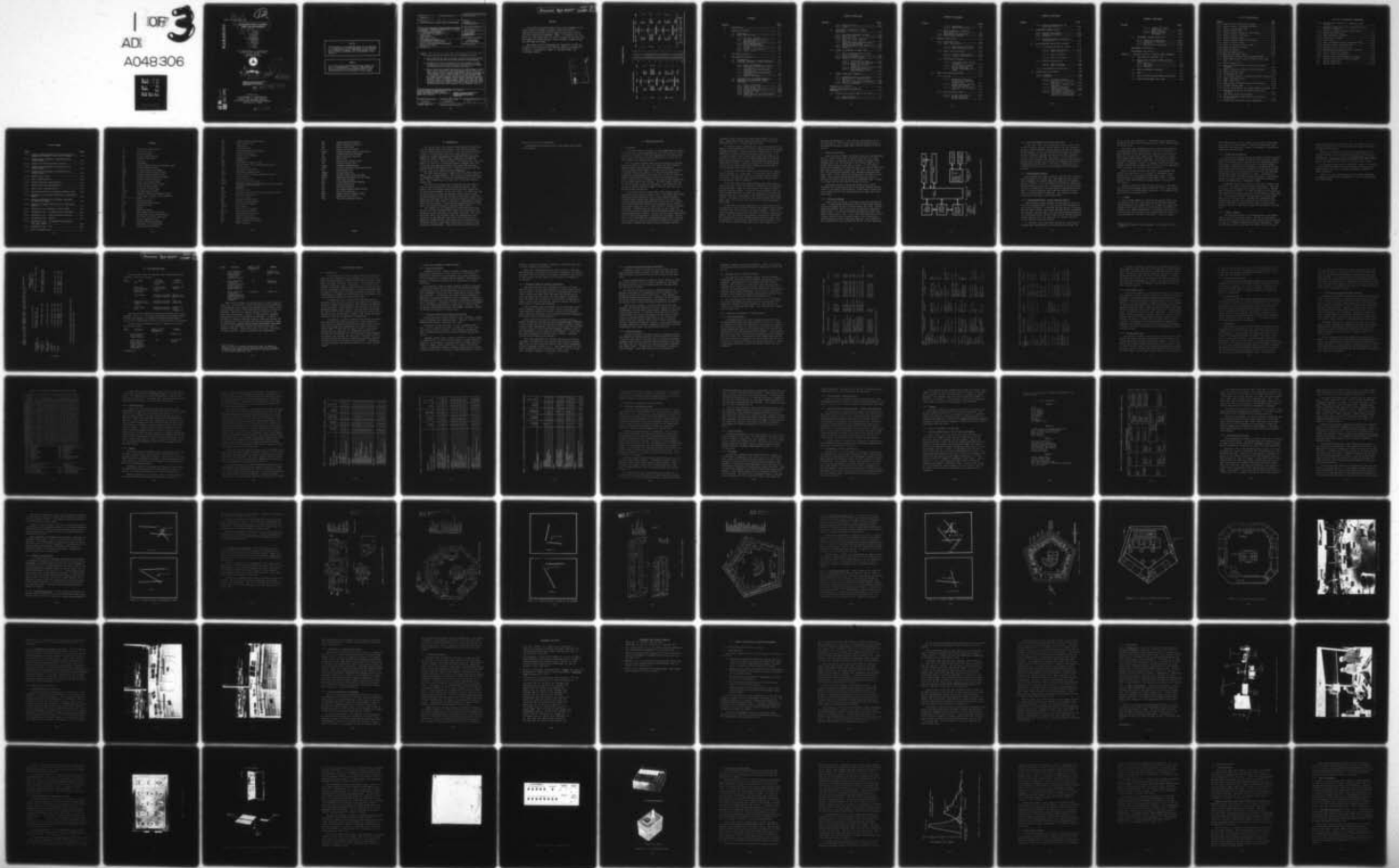

18 19  
REPORT NO. FAA-EM-77-10

12

AD A 048306

6 CHARACTERIZATION OF CURRENT TOWER CAB ENVIRONMENTS.

10  
V. J. Hobbs,  
D. F. Clapp,  
P. Rempfer,  
D. Devoe  
J. Bellantoni  
L. Maddock  
J. Raudseps  
L. Stevenson  
J. R. Coonan  
J. Kuhn  
E. Hilborn

U.S. Department of Transportation  
Transportation Systems Center  
Kendall Square  
Cambridge MA 02142



DDC  
RECEIVED  
DEC 28 1977  
RECEIVED

11  
NOV 1977  
INTERIM REPORT.

9  
Jan-Mar 73

12 246p.

DOCUMENT IS AVAILABLE TO THE U.S. PUBLIC THROUGH THE NATIONAL TECHNICAL INFORMATION SERVICE, SPRINGFIELD, VIRGINIA 22161

14 TSC-FAA-77-29

AD No. —  
DDC FILE COPY

Prepared for  
U.S. DEPARTMENT OF TRANSPORTATION  
FEDERAL AVIATION ADMINISTRATION  
Office of Systems Engineering Management  
Washington DC 20590

407 082

int  
1

NOTICE

This document is disseminated under the sponsorship of the Department of Transportation in the interest of information exchange. The United States Government assumes no liability for its contents or use thereof.

NOTICE

The United States Government does not endorse products or manufacturers. Trade or manufacturers' names appear herein solely because they are considered essential to the object of this report.

1. Report No. FAA-EM-77-10 ✓		2. Government Accession No.		3. Recipient's Catalog No.	
4. Title and Subtitle CHARACTERIZATION OF CURRENT TOWER CAB ENVIRONMENTS				5. Report Date November 1977	
				6. Performing Organization Code	
7. Author(s) V. J. Hobbs, D. F. Clapp, P. Rempfer, D. Devoe, J. Bellantoni, L. Maddock, J. Raudseps, L. Stevenson, J. R. Coonan, J. Kuhn, E. Hilborn				8. Performing Organization Report No. DOT-TSC-FAA-77-19 ✓	
				10. Work Unit No. (TRAIS) FA744/R8119	
9. Performing Organization Name and Address U.S. Department of Transportation Transportation Systems Center ✓ Kendall Square Cambridge MA 02142				11. Contract or Grant No.	
				13. Type of Report and Period Covered INTERIM REPORT Jan. - March 1977	
12. Sponsoring Agency Name and Address U.S. Department of Transportation Federal Aviation Administration ✓ Office of Systems Engineering Management Washington DC 20591				14. Sponsoring Agency Code	
				15. Supplementary Notes	
16. Abstract <p>→ This report describes the general tower cab environment in terms of:</p> <ul style="list-style-type: none"> <li>a) <sup>lc</sup> The evolution of the tower cab, current cab classification and staffing levels, and the basic flow of ATC data relevant to cab operations,</li> <li>b) <sup>lc</sup> A breakdown of functions performed by tower cab personnel, the basic equipment used to perform those functions, and allocation of equipment and responsibilities to various controller positions, <i>and</i></li> <li>c) <sup>lc</sup> Current tower-related systems and procedures, including airspace surveillance, surface surveillance, flight data handling and the role of the flight progress strip, air/ground communications, the data processing and display systems, weather related systems, and current landing systems. The equipments covered included the Airspace Surveillance Radar (ASR), Brite Radar Indicator Equipment (BRITE), Airport Surveillance Detection Equipment (ASDE-2), the NUBRITE display, Display Enhancement Unit (DEU), Flight Data Entry and Printout equipment (FDEP), basic radar PPI, TPX-42 automation and ARTS II and ARTS III displays, Runway Visual Range (RVR) and Runway Visual Value (RVV) equipment, various altimeters, etc. ←</li> </ul>					
17. Key Words Tower Cab, Controller Positions, Tower Cab Systems, Controller Functions, Flight Data Handling, BRITE Display, ASDE-2, FDEP, PPI, Airport Surveillance, Tower Cab Information			18. Distribution Statement DOCUMENT IS AVAILABLE TO THE U.S. PUBLIC THROUGH THE NATIONAL TECHNICAL INFORMATION SERVICE, SPRINGFIELD, VIRGINIA 22161		
19. Security Classif. (of this report) Unclassified		20. Security Classif. (of this page) Unclassified		21. No. of Pages 210	22. Price

*i*

*mt*

NOT  
Preceding Page BLANK - FILMED

PREFACE

This report was prepared under Project Plan Agreement FA-744, "Major Systems Development Programs Integration Analysis", sponsored by the Federal Aviation Administration (FAA), Office of Systems Engineering Management (OSEM). It documents the first phase of a three phase effort to study the impact on the tower cab environment of introducing Major Systems elements (UG3RD Systems) into the CONUS ATC System.

The authors wish to acknowledge the cooperation of many FAA personnel, and in particular the helpful comments and suggestions of Messrs. T. Kolankiewicz (SRDS), H. Wachsman (SRDS), and F. Hierbaum (NAFEC).

ACCESSION for		
NTIS	NTIS Section	<input checked="" type="checkbox"/>
DDC	B.I.F. Section	<input type="checkbox"/>
UNANNOUNCED JUSTIFICATION		
BY _____		
DISTRIBUTION/AVAILABILITY CODES		
Dist.	GENERAL	SPECIAL
A		

METRIC CONVERSION FACTORS

Approximate Conversions to Metric Measures				Approximate Conversions from Metric Measures			
Symbol	When You Know	Multiply by	To Find	Symbol	When You Know	Multiply by	To Find
<b>LENGTH</b>							
in	inches	2.5	centimeters	cm	centimeters	0.04	inches
ft	feet	30	centimeters	cm	centimeters	0.4	inches
yd	yards	0.9	meters	m	meters	3.3	feet
mi	miles	1.6	kilometers	km	kilometers	0.6	miles
<b>AREA</b>							
m <sup>2</sup>	square inches	6.5	square centimeters	cm <sup>2</sup>	square centimeters	0.16	square inches
ft <sup>2</sup>	square feet	0.09	square meters	m <sup>2</sup>	square meters	1.2	square feet
yd <sup>2</sup>	square yards	0.8	square meters	m <sup>2</sup>	square meters	0.4	square yards
mi <sup>2</sup>	square miles	2.6	square kilometers	km <sup>2</sup>	square kilometers	0.4	square miles
acres	acres	0.4	hectares	ha	hectares (10,000 m <sup>2</sup> )	2.5	acres
<b>MASS (weight)</b>							
oz	ounces	28	grams	g	grams	0.035	ounces
lb	pounds (1600 lb)	0.45	kilograms	kg	kilograms	2.2	pounds
	short tons	0.9	tonnes	t	tonnes (1000 kg)	1.1	short tons
<b>VOLUME</b>							
cup	cup	5	milliliters	ml	milliliters	0.03	fluid ounces
Teaspoon	teaspoons	15	milliliters	ml	milliliters	7.1	fluid ounces
fl oz	fluid ounces	30	milliliters	ml	milliliters	1.1	fluid ounces
c	cup	0.24	liters	l	liters	1.06	quarts
pt	pints	0.47	liters	l	liters	0.76	gallons
qt	quarts	0.95	liters	l	liters	35	cubic feet
gal	gallons	3.8	liters	l	liters	1.3	cubic yards
cu ft	cubic feet	0.03	cubic meters	m <sup>3</sup>	cubic meters		
cu yd	cubic yards	0.76	cubic meters	m <sup>3</sup>	cubic meters		
<b>TEMPERATURE (exact)</b>							
°F	Fahrenheit temperature	5/9 (other subtracting 32)	Celsius temperature	°C	Celsius temperature	9/5 (then add 32)	Fahrenheit temperature

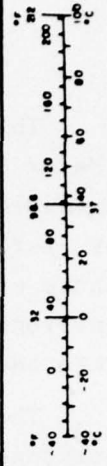

## CONTENTS

<u>Section</u>		<u>Page</u>
1.	INTRODUCTION.....	1-1
2.	TOWER CAB EVOLUTION.....	2-1
2.1	Background.....	2-1
2.2	Tower Classification.....	2-3
2.2.1	VFR Tower (Boston).....	2-3
2.2.2	Non-radar Approach Control (Boston Tower).....	2-5
2.2.3	Radar Approach Control.....	2-5
2.2.4	Tower/RAPCON/TRACON Boston Approach Control.....	2-5
2.2.5	TRACAB.....	2-6
2.2.6	Flight Service Station.....	2-7
2.2.7	Towers-General.....	2-7
3.	CAB STAFFING LEVELS.....	3-1
4.	CAB OPERATIONS ANALYSIS.....	4-1
4.1	INTRODUCTION.....	4-1
4.2	FUNCTIONS PERFORMED BY TOWER PERSONNEL....	4-2
4.2.1	Types of Functions.....	4-2
4.2.2	Functions Involving the Control of Aircraft.....	4-2
4.2.3	Functions Involving Relaying Information.....	4-3
4.2.4	Functions Involving Recording Information.....	4-4
4.2.5	Support Functions.....	4-4
4.3	EQUIPMENT USED TO PERFORM FUNCTIONS.....	4-5
4.4	ALLOCATION OF FUNCTIONS TO TOWER POSITIONS.....	4-5
4.4.1	Types of Positions.....	4-5
4.4.2	Local Control (LC).....	4-9
4.4.3	Ground Control (CG).....	4-9
4.4.4	Clearance Delivery (CD).....	4-10
4.4.5	Flight Data (FD).....	4-10
4.4.6	Supervisor.....	4-10
4.4.7	Other Positions and Consolidated Positions.....	4-11

## CONTENTS (CONTINUED)

<u>Section</u>	<u>Page</u>
4.4.8 TRACAB Positions.....	4-13
4.4.9 Summary.....	4-13
4.5 ALLOCATION OF EQUIPMENT TO TOWER POSITIONS.....	4-18
4.5.1 Some Basic Equipment Packages.....	4-18
4.5.2 Types of Towers.....	4-19
4.5.3 VFR Tower.....	4-19
4.5.4 Tower - No Radar, Approach Control.....	4-20
4.5.5 Tower With Radar Approach Control- TRACAB and Cab/TRACON.....	4-20
4.5.6 Cab/TRACON-ARTS II and ARTS III.....	4-20
4.5.7 Summary.....	4-21
4.6 LAYOUT OF EQUIPMENT IN TOWER CABS.....	4-21
4.6.1 Special Characteristics of the Tower Environment.....	4-21
4.6.2 Factors Affecting Layout.....	4-24
4.6.3 Examples of Cab Layouts.....	4-26
4.6.3.1 Pittsburgh and Miami.....	4-26
4.6.3.2 Kansas City and Houston.....	4-28
4.6.3.3 O'Hare and Portland (Maine).....	4-34
4.6.3.4 NAFEC Experimental Cab.....	4-34
4.6.3.5 Arrangement of Instru- ments in Panels.....	4-40
4.7 CURRENT PERCEIVED PROBLEMS.....	4-40
4.7.1 Standardization vs. Flexibility.....	4-40
4.7.2 Operational vs. Administrative Duties.....	4-43
4.7.3 Need for Integration of Equipment.....	4-43
4.7.4 Controller Workload.....	4-44
REFERENCES for SECTION 4.....	4-45
5. CURRENT TOWER-RELATED SYSTEMS AND PROCEDURES.....	5-1
5.1 Airspace Surveillance Data in the Tower.....	5-1
5.1.1 System Overview.....	5-1
5.1.2 BRITE System.....	5-5

## CONTENTS (CONTINUED)

<u>Section</u>		<u>Page</u>
	5.1.2.1 Background.....	5-5
	5.1.2.2 BRITE-4 Description.....	5-5
5.1.3	BRITE Alphanumeric Equipment Description.....	5-8
5.1.4	Operational Considerations.....	5-15
5.1.5	BRITE System Problems.....	5-18
5.2	SURFACE SURVEILLANCE.....	5-20
5.2.1	System Overview.....	5-20
5.2.2	ASDE-2 Description.....	5-21
	5.2.2.1 Operational Description...	5-21
	5.2.2.2 ASDE-2 Characteristics....	5-25
5.2.3	ASDE-2 System Problems.....	5-32
	5.2.3.1 Airports Without ASDE-2...	5-32
	5.2.3.2 Airports With ASDE-2.....	5-32
5.2.4	ASDE Related Equipment.....	5-33
	5.2.4.1 A New ASDE Bright Display (NU-BRITE).....	5-33
	5.2.4.2 The Los Angeles Ground Surveillance Radar.....	5-38
	5.2.4.3 Display Enhancement Unit (DEU).....	5-40
5.3	TOWER CAB FLIGHT DATA SYSTEM.....	5-42
5.3.1	Overview.....	5-42
	5.3.1.1 Nationwide NAS Stage A Flight Data System-Role of Tower Cab.....	5-42
	5.3.1.2 Ground and Local Control Flight Data System.....	5-45
	5.3.1.3 Cab Flight Data Retention System.....	5-54
5.3.2	FDEP Functional Aspects.....	5-56
	5.3.2.1 Physical Description.....	5-56
	5.3.2.2 Flight Strips and Message Handling.....	5-61

## CONTENTS (CONTINUED)

<u>Section</u>	<u>Page</u>
5.3.3 Current Problems/Tower Cab Flight Data System.....	5-65
5.4 AIR/GROUND COMMUNICATIONS.....	5-67
5.4.1 Physical Description.....	5-67
5.4.2 Frequency Assignment.....	5-69
5.4.3 Operation.....	5-70
5.4.4 Automated Terminal Information System (ATIS).....	5-70
5.5 DATA PROCESSING AND DISPLAY SYSTEMS	5-71
5.5.1 Processing and Display Systems.....	5-71
5.5.1.1 Radar-only Systems.....	5-72
5.5.1.2 TPX-42 Systems.....	5-74
5.5.1.3 ARTS II Systems.....	5-78
5.5.1.4 ARTS III Systems.....	5-82
5.5.2 TRACAB Configurations.....	5-82
5.5.2.1 TPX-42 Systems.....	5-83
5.5.2.2 ARTS II Systems.....	5-83
5.5.3 Tower/TRACON Configurations.....	5-83
5.6 WEATHER-RELATED SYSTEMS.....	5-85
5.6.1 Equipment.....	5-85
5.6.2 Procedures .....	5-95
5.6.2.1 Altimeter Settings.....	5-95
5.6.2.2 Wind Speed and Direction Reading.....	5-103
5.6.2.3 RVR and RVV Readings and Reporting.....	5-104
5.6.2.4 Weather Information Reporting (General).....	5-105
5.6.2.5 Pilot Reports (PIREPS) ...	5-107
5.6.2.6 Significant Meteorological Information (SIGMET) and Notice to Airmen (NOTAM)..	5-107

CONTENTS (CONTINUED)

<u>Section</u>	<u>Page</u>
5.6.2.7 Airport and Runway Conditions.....	5-107
5.6.2.8 Runway Selection.....	5-108
5.6.2.9 Wake Turbulence Procedures .....	5-108
5.7 INSTRUMENT LANDING SYSTEM (ILS).....	5-111
5.7.1 Principles of Operation.....	5-111
5.7.2 Categories of Operation.....	5-112
5.7.3 Use of ILS.....	5-113
5.7.4 Limitations of the System.....	5-114
REFERENCES FOR SECTION 5.....	5-116
BIBLIOGRAPHY FOR SECTION 5.....	5-117
APPENDIX A. TECHNICAL DETAILS OF CERTAIN TOWER EQUIPMENT..	A-1
A.1 PLAN POSITION INDICATOR (PPI).....	A-1
A.2 BRIGHT RADAR INDICATOR TOWER EQUIPMENT.... (BRITE).....	A-1
A.2.1 BRITE-4.....	A-1
A.2.2 ASDE BRITE.....	A-3
A.2.3 NU-BRITE.....	A-4
A.3 BRITE ALPHANUMERIC EQUIPMENT.....	A-5
A.4 ASDE-2.....	A-6
A.5 THE LOS ANGELES GROUND SURVEILLANCE RADAR.	A-11
A.6 DISPLAY ENHANCEMENT UNIT (DEU).....	A-12

## LIST OF ILLUSTRATIONS

<u>Figure</u>	<u>Page</u>
2.2-1 Basic ATC Data Distribution System.....	2-4
4.6-1 Airport Layouts, Pittsburgh and Miami .....	4-27
4.6-2 Layout of Pittsburgh Tower.....	4-29
4.6-3 Layout of Miami Tower.....	4-30
4.6-4 Airport Layouts, Kansas City and Houston.....	4-31
4.6-5 Layout of Kansas City Tower.....	4-32
4.6-6 Layout of Houston Tower.....	4-33
4.6-7 Airport Layouts, O'Hare and Portland.....	4-35
4.6-8 Layout of O'Hare Tower.....	4-36
4.6-9 Layout of Portland, Maine, Tracab.....	4-37
4.6-10 Layout of NAFEC Cab Mockup.....	4-38
4.6-11 NAFEC Cab Mockup.....	4-39
4.6-12 Full Instrument Panel.....	4-41
4.6-13 Modified Instrument Panel.....	4-42
5.1-1 BRITE Radar Indicator Tower Equipment(BRITE-2).....	5-6
5.1-2 BRITE Display Hung Overhead in Boston Logan Tower... Cab.....	5-7
5.1-3 Remote Control Unit.....	5-9
5.1-4 Tower Cab Modification Illustration of Complete Equipment.....	5-10
5.1-5 BRITE-4 Display at Chicago O'Hare With Bands.....	5-12
5.1-6 BRITE A/N Control Panel.....	5-13
5.1-7 A/N Keyboard and PEM.....	5-14
5.1-8 Use of BRITE Display for Runway Clearance Assurance.	5-17
5.2-1 ASDE-2 Equipment Layout.....	5-23
5.2-2 ASDE-2 PPI at JFK.....	5-24
5.2-3 ASDE-2 Radar and BRITE Display Block Diagram.....	5-28
5.2-4 NU-BRITE Control Head.....	5-35
5.2-5 Typical Presentations for Ground Control at O'Hare..	5-36
5.2-6 Typical Presentations for North Local Control at O'Hare.....	5-37
5.2-7 ASDE-BRITE System Block Display.....	5-39
5.2-8 Texas Instruments Ground Surveillance Radar at Los Angeles.....	5-41
5.3-1 Flight Plan Format and Typical Submission.....	5-43

LIST OF ILLUSTRATIONS (CONTINUED)

5.3-2	IFR Departure Flight Strip, Examples of Data Printout.....	5-52
5.3-3	Examples of FDEP Strips for IFR Departures With Controller Markings.....	5-53
5.3-4	Examples of Handwritten Cab Flight Strips.....	5-55
5.3-5	Present FDEP Interfaces.....	5-57
5.3-6	FDEP Alphanumeric Keyboard.....	5-58
5.3-7	Alphanumeric Keyboard.....	5-59
5.3-8	Status Lamps.....	5-60
5.3-9	Tower and Approach Control Departure Strip.....	5-62
5.3-10	Approach Control Overflight Strip.....	5-63
5.3-11	Approach Control Arrival Strip.....	5-64
5.5-1	Representative Displays from Four Systems.....	5-73
5.5-2	TPX-42 System Block Diagram.....	5-75
5.5-3	ARTS-II TRACAB Configuration.....	5-79
5.6-1	Weather and Hazard Equipment for Airports.....	5-86
A-1	Detection Performance in Heavy Rainfall.....	A-10
A-2	Typical Analog DEU.....	A-13
A-3	Typical Digital DEU.....	A-15

## LIST OF TABLES

<u>Table</u>	<u>Page</u>
2.2-1. TYPICAL GROWTH PATTERN OF ATC FACILITIES AT AIR COMMERCE AND GENERAL AVIATION ONLY AIRPORTS.....	2-9
4.4-1. ALLOCATION OF EQUIPMENT TO FUNCTIONS IN FAA CONTROL TOWERS.....	4-6
4.4-2. EXAMPLES OF AUTHORIZED TOWER POSITIONS.....	4-12
4.4-3. ALLOCATION OF FUNCTIONS TO POSITIONS IN FAA CONTROL TOWERS.....	4-15
4.4-4. ALLOCATION OF EQUIPMENT TO POSITIONS IN FAA CONTROL TOWERS.....	4-22
5.2-1. CURRENT ASDE-2 SITES.....	5-22
5.2-2. ASDE-2 CHARACTERISTICS.....	5-26
5.2.3. SYSTEM RESOLUTION CHARACTERISTICS.....	5-30
5.2.4. TARGET DEFINITION CHARACTERISTICS.....	5-30
5.2.5. BRITISH DISPLAY CHARACTERISTICS.....	5-31
5.3.1. FLIGHT DATA VERSUS CAB EQUIPMENT CURRENTLY USED....	5-48
5.6-1. LOCATION OF ASI AND WIND INDICATORS IN SOME MAJOR TOWERS.....	5-89
5.6-2. LOCATION OF RVR/RVV AND CEILOMETER INDICATORS IN SOME MAJOR TOWERS.....	5-90
5.6-3. LOCATION OF TRANSCRIPTION DEVICES IN SOME MAJOR TOWERS.....	5-91
5.6-4. LOCATION OF ATIS EQUIPMENT AT MAJOR TOWERS.....	5-92
5.6-5. INFORMATION FLOW - ALTIMETER SETTING INDICATOR.....	5-96
5.6-6. INFORMATION FLOW - WIND SPEED/WIND DIRECTION.....	5-97
5.6-7. INFORMATION FLOW - RVR/RVV.....	5-98
5.6-8. INFORMATION FLOW - ELECTROWRITER/TELAUTOGRAPH (NON-LAWRS TOWERS).....	5-99
5.6-9. INFORMATION FLOW - ATIS.....	5-101
A-1. ASDE-2 CHARACTERISTICS.....	A-7

## GLOSSARY

AAF	Airways Facilities Service
AAT	Air Traffic Service
AC	Approach Control
ACID	Aircraft Identification
ACP	Azimuth Change Pulse
A/C	Aircraft
A/N	Alphanumeric
ALSF	Approach Light System with Flashing Lights
ARP	Azimuth Reference Pulse
ARSR	Air Route Surveillance Radar
ARTCC	Air Route Traffic Control Center
ARTS	Automated Radar Terminal System
ASDE	Airport Surface Detection Equipment
ASI	Altimeter Setting Indicator
ASR	Airport Surveillance Radar
ASTC	Airport Surface Traffic Control
ATC	Airport Traffic Control
ATCT	Air Traffic Control Tower
ATCRBS	ATC Radar Beacon System
ATIS	Automatic Terminal Information Service
BRITE	Bright Radar Indicator Tower Equipment
CAT I, II, III	Category I, II, III
CD	Clearance Delivery
CONUS	Continental United States
CRT	Cathode Ray Tube
DB	Decibel
DC	Departure Control
DCCU	Data Communication Control Unit
DDAS	Decoding Data Acquisition Subsystem
DEDS	Data Entry and Display Subsystem
DEU	Display Enhancement Unit
DME	Distance Measuring Equipment
DOT	Department of Transportation
DPS	Data Processing Subsystem

FAA	Federal Aviation Administration
FAF	Final Approach Fix
FD	Flight Data
FDB	Full Data Block
FDEP	Flight Data Entry and Printout
FSP	Flight Strip Printer
FSS	Flight Service Station
GC	Ground Control
GHz	GigaHertz
HIRL	High Intensity Runway Lights
ICOA	International Civil Aviation Organization
ID	Identification
IFR	Instrument Flight Rules
ILS	Instrument Landing System
LAWRS	Limited Aviation Weather Reporting Service
LC	Local Control
LDB	Limited Data Block
LLTV	Low Light Level Television
MALSR	Medium-intensity Approach Light System with Runway alignment indicator lights
MHz	MegaHertz
MSL	Mean Sea Level
NAFEC	National Aviation Facilities Experimental Center
NDB	Non-Directional Beacon
NOTAM	Notice to Airmen
NWS	National Weather Service
PAR	Precision Approach Radar
PEM	Position Entry Module
PIREPS	Pilot Reports
PPI	Plan Position Indicator
RAPCON	Radar Approach Control
RBC	Rotating Beam Ceilometer
RBS	Radar Beacon System
RCR	Runway Condition Readings
REIL	Runway End Identifier Lights
RF	Radio Frequency

RRH	Remote Reading Thermometer
RTR	Remote Transmitter-Receiver
RVR	Runway Visual Range
RVV	Runway Visibility Value
SIGMET	Significant Meteorological Information
SOP	Standard Operating Procedure
SPI	Special Position Indicator
SVFR	Special VFR
TAGS	Tower Airport Ground System
TCA	Terminal Control Area
TELCO	Telephone Communications
TIPS	Terminal Information Processing System
TML	TV Microwave Link
TRACAB	Terminal Radar Cab
TRACON	Terminal Radar Control Facility
UG3RD	Upgraded Third Generation ATC System
UHF	Ultra High Frequency
VASI	Visual Approach Slope Indicator
VFR	Visual Flight Rules
VHF	Very High Frequency
VOR	VHF Omnidirectional Range Station
WSD	Wind Shear Detection
WSFO	Weather Service Forecast Office
WSO	Weather Service Office
WVAS	Wake Vortex Advisory System

## 1. INTRODUCTION

This is the first of a series of three interim reports which will be combined into a final report on the subject of tower-related systems integration analysis. The tower systems analysis is part of a joint study team activity whose purpose it is to examine the planned implementation of Upgraded Third Generation (UG3RD) Air Traffic Control system elements in the CONUS ATC system for the 1985 - 1990 time frame. The objectives of the joint team are to carry out a study and produce a document that will: 1) describe and highlight technical and operational interface between UG3RD system elements and 2) identify interface and time phasing issues to be addressed by FAA management.

The study team consists of members from FAA (OSEM, SRDS, and NAFEC), TSC, and MITRE METREK. FAA's Office of Systems Engineering Management (OSEM) is leading and coordinating the joint study team. TSC's responsibility on this team is the tower-related systems area.

The current ATC systems must be examined and described in order to form a baseline for the integration analysis. This report forms the baseline description of the tower systems and the tower cab environment as they exist today. An effort was made to touch upon all systems and functions which relate to tower operations and which might be affected in the future by the integration of UG3RD systems such as Wake Vortex Advisory (WVAS), Wind Shear Detection (WSD), ARTS III and ARTS II Enhancements, Airport Surface Traffic Control - Tower Airport Ground Surveillance (ASTC-TAGS), and Terminal Interface Processing System (TIPS).

This report will be followed by a second report which will describe the tower-related UG3RD systems, their development and deployment status, equipment, and planned interfaces. The third and major report will postulate tower cab configurations and operations in the 1985-1990 time-frame, after integration of appropriate UG3RD elements, and analyze the resulting tower cab situation relative to operations, human factors, displays, and automation considerations. General interface problems and time-

phasing issues will be highlighted.

Abbreviations and acronyms used in this report may be found in the Glossary.

## 2. TOWER CAB EVOLUTION

### 2.1 BACKGROUND

Air Traffic Control to towers has been established to provide for a safe, orderly and expeditious flow of traffic on and in the vicinity of an airport. When the responsibility has been so delegated, towers also provide for the separation of IFR aircraft in the terminal areas (Approach Control).

The first radio equipped tower cab was installed at Cleveland Municipal Airport in 1930. The first towers were not federally funded but were owned privately or by local governments. The cab responsibilities were to sequence arrivals for landing and to regulate runway utilization (i.e., arrivals and departures). Separation was maintained by the pilots on a see and be seen basis. Guidance and navigation between airports was performed by the pilots through the use of radio or light beacons and somewhat later by four-course radio range stations. The only control exercised was at the airports by the cab controllers. The control was VFR in nature, and the majority of today's over 400 tower cabs still operate in much the same way.

In the early 1930's, aircraft began flying between airports using radio range stations, compass, etc., (IFR flight) when visual conditions did not permit the use of visual ground references. Several airports became quite congested even in IFR conditions. To permit sequencing and separation of IFR aircraft, the airlines established three Airway Traffic Control Centers, which covered the airspace within 50 miles of three airports: Chicago, Cleveland, and Newark. Communication with the pilots in the airspace was carried out over voice radio by airline dispatchers and/or airline ground communication stations. The ATC Centers in turn communicated with the stations/dispatchers by ground line interphone. Surveillance of the IFR traffic was accomplished through pilots reporting their positions by radio to the ground stations to be relayed to the Centers. Reports were required every 15 minutes, and the

location of each aircraft was tracked using markers on an area map. Flight data on each target was maintained at first on a blackboard and later on flight progress strips.

In 1936, the Federal government took over the operation of the ARTCC's (first generation ATC system). Through 1941 the government expanded the number of Centers and their coverage until in 1942 there were 23 Centers giving 100 percent airway coverage. The Air Route Traffic Control Centers were established primarily to provide air traffic service to aircraft operating on IFR flight plans within controlled airspace, and principally during the en-route phase of flight. Teletype systems were installed between Centers and the ground Aeronautical Communications Stations to facilitate the message relay function.

In 1941, the government extended its jurisdiction to Airport Traffic Control, i.e., tower cabs. For the first time, conventional non-radar approach control was delegated from the Center to the cab. By 1946 there were 146 tower cabs although only a few had approach control authority.

In the late 1940's the second generation ATC system began to evolve with direct pilot to controller communication and the introduction of radar. Radar was first used in the airport terminal area for approach control. Initially it was installed in the cab with a viewing hood but soon after was installed in a special low-ambient-light-level room, known as the TRACON, for Terminal Radar Control. The radar for TRACON use was called Airport Surveillance Radar (ASR). That used by the center was Air Route Surveillance Radar (ARSR).

In the 1960's, the third generation ATC system began with the introduction of the Air Traffic Control Radar Beacon System (ATCRBS) and Flight Data Entry and Printout (FDEP) equipment. ATCRBS provided an enhanced radar target with which to identify each equipped target. FDEP facilitated the exchange of flight plan information and flight progress strips between centers and major towers which was previously accomplished by means of teletype equipment. Also in the 1960's, airport ground surveillance radar (ASDE-2) was

developed and deployed as a low visibility surveillance aid to cab controllers. The TV video-scan-converted bright display was introduced permitting a bright ASDE-2 and ASR display for use in the cab.

## 2.2 TOWER CLASSIFICATION

Towers have had a number of different types of classifications over the years and have come a long way since the first radio equipped tower. It operated on low and medium frequency radio equipment and, with the exception of air carriers, many of its patrons had no radio, or had only a receiver. It and similar towers that followed in the next few years were strictly VFR towers. Their only responsibility relative to IFR traffic was to insure that IFR arrivals and departures were adequately protected from other traffic. These towers were connected to the ARTCC by interphone. They received and delivered IFR clearances, and also provided the Center with IFR arrival and departure times. Figure 2.2-1 shows the basic ATC data distribution system.

Operational necessity forced the growth of air traffic management and its associated facilities which included classification, size, manning, and equipment. Using Boston's Logan Tower as an example, we can trace the evolution of a tower cab to the present day.

### 2.2.1 VFR Tower (Boston)

Boston Tower started as a municipally owned and operated VFR tower. It guarded and transmitted on two or three radio frequencies and was manned by one or two controllers per shift. One man handled the traffic and his assistant or supervisor handled the other details. As traffic increased, additional personnel were added to busy shifts. Their duties were broken down into classifications similar to those of today, namely a local controller, a ground controller, and a flight data position. VHF frequencies were installed for civil aviation and UHF for military operations.

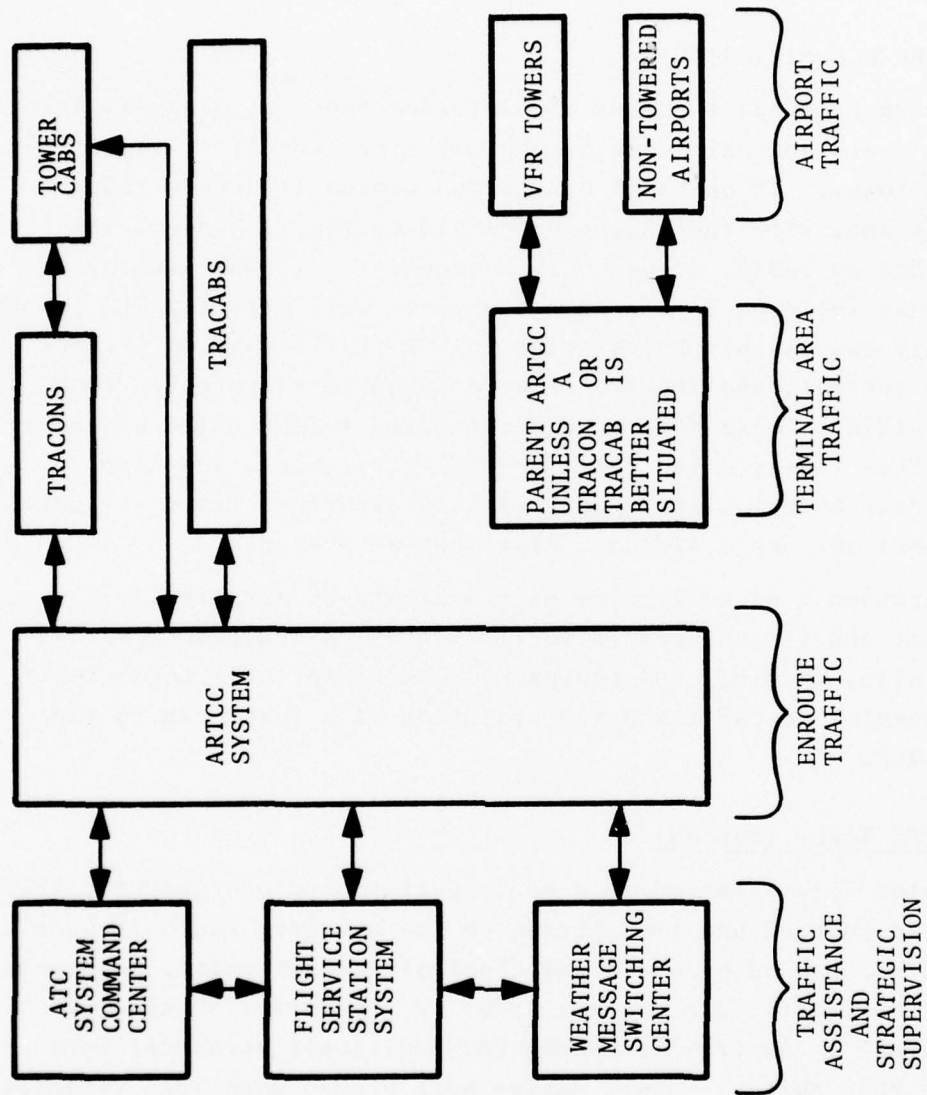

FIGURE 2.2-1. BASIC ATC DATA DISTRIBUTION SYSTEM

#### 2.2.2 Non-radar Approach Control (Boston Tower)

In the early 1940's due to additional traffic, ARTCC's were forced to delegate approach control authority to busy terminals. The tower still retained VFR responsibility, and for the approach control function, it was given additional horizontal and vertical airspace, additional manning, and one or more radio frequencies for the arrival and departure IFR traffic. As IFR traffic increased in the terminal area, additional altitudes were authorized, and horizontal airspace was increased to accommodate VFR towered or untowered satellite fields. The tower's responsibility at satellite fields was only for the IFR traffic in the designated airspace.

#### 2.2.3 Radar Approach Control

Some attempts were made in late 40's and early 50's to bring radar information in to tower cabs from nearby military radars. This arrangement did provide additional capability for approach control. However, it was not completely satisfactory because the radar scan rate was slow, and it was necessary to hood the scopes in order to compensate for the high ambient light during the daytime. A precision approach radar (PAR) was installed in some towers, for monitoring ILS approaches. Once again its utility was limited by the need to use hooded scopes.

#### 2.2.4 Tower/RAPCON/TRACON - Boston Approach Control

Radar Approach Control (RAPCON) was developed in the early 1950's by the United States Air force and was the forerunner of the current FAA TRACON. It used the IFR room concept (a separate room for radar displays) and clearly demonstrated its operational effectiveness and paved the way for the current TRACON operation. It is mentioned here to show the transition of the radar approach control function out of the tower cab to a separate facility, usually located in the same building.

As time went on, the question was raised as to the value of remoting radar presentations in the IFR room to the tower cab

for use by the local controller. The BRITE\* display concept was developed, and today busy terminals have one or more BRITE displays in the tower cab.

Also during this evolutionary period, Airport Surface Detection Equipment (ASDE) was developed. At first it was used to survey portions of the ramp area that could not be seen from the tower cab since most early towers were placed on two- or three-story airport administration buildings. Now, most busy airports have high-elevation towers so that much of the ramp visibility problem is eliminated. However, as landing visibility minima were reduced, ASDE became a valuable tool for low-visibility approaches, runway crossings, and taxiway traffic operations.

Many of the busy terminals have ASDE-2 type equipment and despite some limitations it is valuable in increasing airport capacity as well as in improving operational safety. A new, improved ASDE-3 is scheduled for procurement by 1980. Further details on both BRITE displays and ASDE appear in Section 5 of this report.

Currently the Boston Tower Cab has reverted to a VFR tower with some limited approach control authority for the local controllers because of its BRITE display capability. This completes the description of the Boston Tower.

#### 2.2.5 TRACAB

The so-called TRACAB is relatively new concept, with 39 installations in the U.S. Many towers having non-radar approach control authority and responsibility for a number of towered and untowered satellite fields do not currently have the traffic to warrant a full TRACON installation. At a TRACAB site, an ASR is installed near the tower and using the BRITE display concept, the radar information is relayed to the tower. There are usually

---

\* Bright Radar Indicator Tower Equipment. See Section 5 for Discussion.

three BRITE displays; one for radar arrival, one for radar departure, and one for Local Control. Usually two additional radio frequencies are added and the number of personnel is increased to handle the radar positions.

#### 2.2.6 Flight Service Stations

Flight Service Stations are the Air Traffic Service facilities within the National Airspace System, which have the prime responsibility for preflight pilot briefing, en route communications with VFR flights, assisting lost VFR aircraft, originating NOTAMS, broadcasting aviation weather information, accepting and closing flight plans, monitoring radio NAVAIDS, participating with search and rescue units in locating missing VFR aircraft, and operating the national weather teletypewriter systems. In addition, at selected locations, FSS's take weather observations, issue airport advisories, administer airman written examinations, and advise Customs and Immigration of transborder flight.

The modern Flight Service Stations (FSS) were created in the early 1950's to satisfy General Aviation requirements. Many were in quarters that included pilot briefing rooms with U.S. Weather Bureau personnel available. At other locations, one ATC specialist with appropriate training carried out the FSS function in the tower cab. This individual provided all the services of a FSS except face-to-face pilot briefings. Although this arrangement was operationally suitable, the presence of the FSS with its teleprinters introduced a disruptive noise factor into the tower. Currently the FAA is phasing out Flight Service Stations in tower cabs.

#### 2.2.7 Towers - General

There are approximately 12,000 landing areas in the United States; in 1976, 413 had FAA towers. The FAA has continually modified the original criteria for tower installation and staffing in order to accommodate changing operational requirements. There are some older towers which would not qualify for their present

classification under the latest criteria. Some towers that do not qualify under the tower activity criteria qualify for economic or other special reasons.

There are still towers which are FAA certificated, but are not FAA operated. Most towers operate from early morning to late evening, i.e., 12, 16, or 18 hours a day depending on the nature of the traffic. Furthermore, there are seasonal towers that operate only in the summer, and, of course, there are military towers.

In conclusion, where there is a need for a tower it is usually satisfied, and the nature of the need dictates the tower qualification level as well as its staffing, equipment, and number of radio frequencies.

Table 2.2-1 shows typical levels of air traffic operations for which particular tower configurations, services, and equipment have been provided.

TABLE 2.2-1. TYPICAL GROWTH PATTERN OF ATC FACILITIES AT AIR COMMERCIAL AND GENERAL AVIATION ONLY AIRPORTS (Ref: DOT/FAA/ASP-110 7031.2B)

	(Sch. Air Carriers Only)	GENERAL AVIATION AIRPORT (GA Aircraft Only)
ILS Runway At Non-towered Airport	Sustained Sch. Air- Carrier Turbojet Ops.	≥ 700 Annual Instr. Approaches
VFR Control Tower	≥ 15,000 Annual Itin. Ops.	≥ 200,000 Annual Total Ops. (i.e., Itinerant & Local)
Remote BRITE Display	≥ 35,000 Annual Itin. Ops.	
ASR/RBS*	≥ 50,000 Annual Itin. Ops.	
ATIS**	≥ 50,000 Annual Itin. Ops.	≥ 100,000 Annual Itin. Ops.
TRACON	≥ 100,000 Annual Itin. Ops. Plus	≥ 100,000 Annual Itin. Ops. Plus
	≥ 20,000 Annual Instr. Ops.	≥ 20,000 Annual Instr. Ops.

\* Airport Surveillance Radar/Radar Beacon System

\*\* Air Traffic Information Service

### 3. CAB STAFFING LEVELS

There are five levels of operation used in determining tower staffing. They are as follows:

<u>Level</u>	<u>Type</u>	<u>Staffing</u>	<u>Example</u>
1	VFR	8 Controllers 1 Chief	Hyannis, MA
2	Heavy VFR or/Conventional Appr. Control or TRACAB	12 Controllers 2 Ass't Chiefs 1 Chief	Portland, ME TRACAB
3	Tower/TRACON	Variable according to Special Factors	Bradley Int. Windsor Locks, CT
4	Usually TCA's (Terminal Control Areas)	Variable according to Special Factors	Logan Int. Boston, MA
5	Heavy Volume TCA's	Variable according to Special Factors	Atlanta, GA O'Hare, Chicago, IL

One can see that staffing for level one and level two is well-defined. Level 3, 4, and 5 towers are usually Tower/TRACON installations whose manning is dictated by operational requirements. Level 4 and 5 installations are TCA's for which there is no standard.

For each level of operation there is a defined set of tower positions as follows:

<u>Level</u>	<u>Positions</u>	<u>Number of VHF Frequencies</u>	<u>Example</u>
1	Shift Supervisor Local Control Ground Control	2/3	Hyannis, MA
2	Shift Supervisor Local Control Ground Control Radar Arrival* Radar Departure* Flight Data	3/4	Portland, ME TRACAB

\*TRACABS only

<u>Level</u>	<u>Positions</u>	<u>Number of VHF Frequencies</u>	<u>Example</u>
3	Shift Supervisor Local Control Ground Control Flight Data Clearance Delivery	4/5	Bradley Int. Windsor Locks, CT
4	Shift Supervisor Flight Data Clearance Delivery Ground Control Local Control (2) Skyway Control*	5/6	Logan Int. Boston, MA
5	Shift Supervisor Flight Data Clearance Delivery Ground Control (2) Local Control (3) Gatehold	As Required	Atlanta, GA

There are few problems in staffing Level 1, 2, and 3 types of tower cabs. Levels 4 and 5 in many instances do have problems due to the apparent stress involved in handling the air traffic associated with these towers. The ground control position is often very demanding. Relief can be obtained through utilization of two ground control positions. However, at some airports, geography and ground traffic patterns make this impossible. In Denver, Colorado, for example, Stapleton Airport's runway and taxiway layout combined with a narrow congested ramp area containing a number of intersections, **requires that a single person handle the ground traffic**, since coordination between two controllers would be extremely difficult. During busy periods of the day, the ground controller carries on nearly continuous radio communication.

\* Skyway Control is a special factors position. At Logan, it operates 5 days a week during commuting rush hours to handle helicopters and light aircraft reporting on the ground traffic in the Boston metropolitan area.

## 4. CAB OPERATIONS ANALYSIS

### 4.1 INTRODUCTION

In establishing the baseline against which to estimate the impact of the introduction of new equipment into the tower cab under the UG3RD program, it would be desirable to describe a standard, or average, or typical cab of today. Unfortunately, such a standard cab does not exist. Alternatively, it is necessary to identify the elements common to many cabs and to develop the logic for the assignment of these elements to various cab positions and locations as a function of the total operational situation. The relationships of elements to cab locations are illustrated in this section through examples of various cab layouts.

The approach used is to define the functions that ATC specialists must carry out in cabs and to identify the equipment now used to support these functions. The allocation of functions to duty positions is then addressed, and some basic and special equipment packages usually found at these positions are defined. The specific way in which positions are located in various cabs is illustrated for several towers. Finally, some current perceived problems related to cab operations are identified.

This analysis is based on detailed descriptions of control tower operations developed in support of a system simulation project<sup>1</sup> and an improved airport surface traffic control system.<sup>2</sup> These descriptions were supplemented with popular articles on control towers<sup>3,4</sup> and visits to control towers in Boston, MA; Philadelphia, PA; Baltimore, MD; Washington (National) DC; Portland, ME; and Bedford, MA. Detailed data on tower equipment and layouts were obtained from the series: "Terminal Facilities Configuration and Data Survey," published by the FAA's National Aviation Facilities Experimental Center (NAFEC).<sup>5</sup> Information on tower procedures was taken from the DOT "Air Traffic Control" manual.<sup>6</sup>

## 4.2 FUNCTIONS PERFORMED BY TOWER PERSONNEL

### 4.2.1 Types of Functions

Although positions, layouts, and duty assignments may differ significantly from tower to tower, there are certain functions that must be performed by the personnel in any tower wherever it may be and however its contents may be arranged. These functions provide a convenient starting point for the analysis of tower operations.

Very generally, tower personnel perform two major functions; 1) they issue instructions to the pilots of aircraft to maintain safe separation both, on the ground and in the air, and 2) they relay information to help the pilots manage their aircraft safely and efficiently. In addition, they record certain information. Some kinds of recorded information serve as reminders to help the controllers perform their major functions (operational information); other information is recorded to fulfill FAA and local requirements for record keeping (administrative information). Finally, there are general housekeeping functions that support operations, making it possible to perform the primary tasks.

### 4.2.2 Functions Involving the Control of Aircraft

Control functions include issuing various clearances, issuing specific commands, and asking questions. These all involve direct communication between a controller and a pilot.

Clearances include permission to start a pushback from a gate, to start taxiing to a runway, to take off, to land, and to taxi across a runway or taxiway. Each clearance includes the basic information required by the pilot to perform the function safely.

Commands include orders, such as to hold at a given position, to resume taxiing, to yield to other traffic, to report back to a controller on arriving at a specified point, to change radio frequency, to contact another controller, to execute a missed approach, to transpond ("squawk") a specific beacon code, to follow a specified taxi route, to execute a specified heading or turn, to

maintain a specified altitude, to maintain a specified speed, and to execute emergency instructions.

Queries may include questions as to an aircraft's location, identification, or destination; the pilot's intentions; the traffic observable from the aircraft; the weather conditions in the vicinity of the aircraft; and the status of the aircraft or occupants in an emergency.

#### 4.2.3 Functions Involving Relaying Information

Tower personnel may relay information to pilots, to other tower personnel, to other ATC personnel or to other people outside the ATC system. The principal kinds of information they relay to pilots include data about flight clearances and information on local conditions that can affect the safe movement of aircraft. They also report the occurrence of various events to appropriate agents, receive such notifications from these agents, and pass on notifications to other tower personnel.

Flight clearance data transmitted to pilots may simply verify that a clearance is approved as filed. Often, controllers must inform pilots of changes in clearance, beacon code assignments, radio frequencies to monitor or use, runway and taxiway assignments, and various restrictions on operations.

Local conditions relayed from tower to aircraft include weather information (routing plus such specialized data as RVR, RVV, vortex warnings and wind shear hazards), SIGMETS, NOTAMS, altimeter setting, runway information, specialized restrictions, and location of other aircraft (on the ground and airborne). Sometimes much of this information is voice taped for ATIS broadcast. In this case, the letter designating the current ATIS in effect is routinely relayed from the tower to the aircraft.

Often, such information is relayed from person to person in the tower, or between the tower and other ATC facilities (TRACON, ARTCC, FSS) or other interested agencies (NWS, airport management, airlines, emergency services, etc.). Such communications may also entail notification of the occurrence of events, such as, a take-off, a landing, a handoff, a gate hold, and the like.

#### 4.2.4 Functions Involving Recording Information

Information regularly recorded in towers includes the time that significant events occurred, the simple fact that certain events occurred, and various items of data relevant to the operations.

Times recorded regularly include the time of takeoff or landing of each aircraft, the time a missed approach was initiated, the time of delivery of each clearance, and the time gate holds were initiated or removed.

The fact that an event occurred is recorded generally by putting a check mark in a designated location or drawing a line through a recorded item on the flight strip. Items regularly checked off include the delivery of a clearance, the notification to a pilot of beacon code assignment, the completion of a handoff, and the fact that a clearance has been validated by the ARTCC.

Items of data regularly recorded include the beacon code assigned, the gate for departure or arrival, changes in previously recorded data, and additional items locally required for entry on flight progress strips. It should be noted that local facility directives may also require the emphasis of some data on flight strips by circling or underlining, often in red. Records of traffic counts are regularly made on special forms, sometimes initially recorded on mechanical counters. Taped voice recordings are made periodically in towers equipped with the ATIS system for broadcasting local weather and operational conditions.

#### 4.2.5 Support Functions

In order to perform the required control, information relay, and information recording functions, tower personnel must be able to exercise some control over many items of supporting equipment. Equipment control devices therefore must be operated in the tower. All towers have the capability for controlling runway, approach, and taxiway lights. In some towers, the occupants can control radar equipment. Every BRITE display must be adjusted for

brightness, contrast, and other parameters. There is also provision for monitoring and controlling such landing aids as DME, VOR and ILS.

#### 4.3 EQUIPMENT USED TO PERFORM FUNCTIONS

Each function to be performed requires certain equipment. Communications functions require telephone, interphone, and radio equipment. Monitoring of air and ground situations requires windows. When visibility is restricted, radar and television equipment may be used, with associated displays and controls in the cab. To relay information, one must receive it; thus printers, electrowriters, weather instruments, and the like are required. Likewise, switch and control panels are needed for turning lights on and off, selecting and tuning radio equipment, etc.

For each function described in Section 4.2, the information and action requirements associated with the function have been identified, together with the equipment or aids currently in general use for meeting these needs. This information is summarized in Table 4.4-1.

#### 4.4 ALLOCATION OF FUNCTIONS TO TOWER POSITIONS

##### 4.4.1 Types of Positions

The United States Civil Service Commission Position-Classification Standards describe tower positions in this way: "Work in terminals is divided into functions or 'positions of operation.' One function may consist of controlling aircraft on the ground: a second function may consist of assigning runways to arriving and departing aircraft and sequencing their movements; a third function may consist of controlling arriving and departing traffic through the use of radar, etc. Controllers rotate through the functions for relief from the continuous stress and pressure that are characteristic of the most difficult 'positions of operation.' Normally during an average day, controllers perform several of these functions."<sup>7</sup>

TABLE 4.4-1 ALLOCATION OF EQUIPMENT TO FUNCTIONS IN FAA CONTROL TOWERS

FUNCTION	INFORMATION REQUIREMENTS	EQUIPMENT USED	ACTION REQUIRED	EQUIPMENT USED
<u>CONTROL AIRCRAFT</u>				
<u>Clearances</u>				
To pushback	Clear space behind A/C	Window, ASDE	Issue clearance to pilot	Radio
To taxi	Traffic permits A/C movement	Window, ASDE	Issue clearance to pilot	Radio
To takeoff	Runway is clear	Window, ASDE	Issue clearance to pilot	Radio
To land	Runway is clear	Window, ASDE	Issue clearance to pilot	Radio
To cross runway or taxiway	Intersection is clear	Window, ASDE	Issue clearance to pilot	Radio
<u>Commands</u>				
Hold	Traffic conflict noted	Window, ASDE	Issue instructions to pilot	Radio
Yield	Traffic conflict noted	Window, ASDE	Issue instructions to pilot	Radio
Report back	A/C Location	Window, ASDE	Issue instructions to pilot	Radio
Contact	Handoff to another controller required, frequency	Window, ASDE, ASDE, BRITE, References*	Issue instructions to pilot	Radio
Resume taxing	Runway or taxiway is clear	Window, ASDE	Issue instructions to pilot	Radio
Execute missed approach	Landing unsafe, procedure	Window, BRITE	Issue instructions to pilot	Radio
Squawk	Aircraft ID uncertain	Window, ASDE, BRITE	Issue instructions to pilot	Radio
Taxi route	Availability of runways and taxiways	Window, ASDE	Issue instructions to pilot	Radio
Hdgs and turns	Location of other traffic, terrain and obstructions	Window, ASDE, BRITE, charts, TV	Issue instructions to pilot	Radio
Altitude	Location of other traffic, terrain and obstructions	Window, ASDE, BRITE, charts, TV	Issue instructions to pilot	Radio
Speed	Location of other traffic	Window, BRITE	Issue instructions to pilot	Radio, signal light
Emergency instructions	Info from pilot, procedure	Radio, references	Issue instructions to pilot	Radio, signal light
<u>Queries</u>				
Location	A/C location unknown	Radio	Request info from pilot	Radio
Destination	A/C destination unknown	Radio	Request info from pilot	Radio
Intentions	A/C intentions unknown	Radio	Request info from pilot	Radio
Traffic	Traffic pattern unknown	Radio	Request info from pilot	Radio
Emergency information	Type of emergency	Radio	Request info from pilot	Radio

\*"Reference" denotes printed lists, instructions, bulletins and the like that the controller refers to for the required information.

TABLE 4.4-1 ALLOCATION OF EQUIPMENT TO FUNCTIONS IN FAA CONTROL TOWERS (CONTINUED)

FUNCTION	INFORMATION REQUIREMENTS	EQUIPMENT USED	ACTION REQUIRED	EQUIPMENT USED
<u>RELAY INFORMATION</u>				
File Clearance Data to aircraft	Verification from ARTCC	FDEP, Intercom.	Read clearance to pilot	Radio
Cleared as filed	Change from ARTCC, Information from ARTS, ARTCC	FDEP, Intercom. BRITE, Intercom.	Read clearance to pilot	Radio
Beacon assignment	Frequency	References	Read assignment to pilot	Radio
Contact frequency Restrictions	Information from ARTCC	FDEP, Intercom.	Inform pilot of new frequency	Radio
Runway/taxiway assignments	Procedure	References	Inform pilot of restrictions	Radio
Local Conditions	Weather Office Visibility on field	Telautograph Displays from sensors on field	Inform pilot of assignments	Radio
Weather RVR, RVV	Status of equipment and facilities	Equipment status displays and posted notices	Generate ATIS tape	ATIS recorder, Radio
NOTAMS	Readout of altimeter	Altimeter	Inform pilot	Radio, ATIS
Altmttr setting	Wind speed and direction	Wind instruments	Inform pilot	ATIS, radio
Runway in use	Knowledge of restrictions	References	Update ATIS if required. Assure that pilots have current info.	ATIS, radio
Restrictions	NOTAMS		Update ATIS if required. Inform TRACON of runway changes	ATIS, phone
Traffic ATIS in effect	Proximity of other A/C Letter of current ATIS	BRITE, window, ASDE BRITE	Inform pilot	Radio
Runway condition	Knowledge of slippery or rough runways	Radio for PIREPS	Alert pilots Ascertain that pilots have current ATIS	Radio
Notifications to or from:			Inform other pilots	Radio
Other tower personnel TRACON	Impending handoffs and similar info. Impending handoffs and similar info.	Voice	Receive concurrence	Voice
ARTCC, FSS	Delivery of flight plans	Phone, intercom	Receive concurrence	Phone, intercom
Other local airport operations	Status info + flight plans from FSS	FDEP Phone	Prepare flight strips	Flight strip racks
Other airports	Status info., VER flight plans to destination	Phone	Inform other tower personnel	Voice
Emergency contacts	Knowledge of type of emergency	Phone, radio	Inform other tower personnel Contact appropriate sources	Voice Radio, phone

TABLE 4.4-1 ALLOCATION OF EQUIPMENT TO FUNCTIONS IN FAA CONTROL TOWERS (CONTINUED)

<u>FUNCTION</u>	<u>INFORMATION REQUIREMENTS</u>	<u>EQUIPMENT USED</u>	<u>ACTION REQUIRED</u>	<u>EQUIPMENT USED</u>
<u>RECORD INFORMATION</u>				
Time of Takeoff	Knowledge that A/C has taken off	Window, ASDE, Clock	Record time on flight strip	Flight strips
Landing	Knowledge that A/C has landed	Window, ASDE, Clock	Record time on flight strip	Flight strips
Missed Approach	Knowledge that A/C has aborted	Window, Clock, Radio	Record time on flight strip	Flight strips
Clearance delivery	Readback by pilots	Radio, clock	Record time on flight strip	Flight strips
Gate delay	A/C being held	Window, ASDE, clock	Record time on flight strip	Flight strips
Check				
Clearance delivered	Action completed		Mark flight strip	Flight strips
Beacon code assigned	Action completed		Mark flight strip	Flight strips
Handoff completed	Action completed		Mark flight strip	Flight strips
Clearance validated	Validation from ARTCC	Intercom	Mark flight strip	Flight strips
<u>Data</u>				
Beacon assigned	Knowledge of beacon assignment	Beacon Assignment, Panel, BRITE, ARTS keypad	Enter beacon assignment	Flight strip
ATIS generation	Outages or weather changes	All status and WX readouts	Record new ATIS info.	ATIS recorder
Traffic Count	Arrivals and departures per hour	Flight strips	Activate counter or count flight strips	Flight strips, counter
Gate Assigned	Call from airline	Phone	Mark flight strips	Flight strips
Other Flight Strip Data	Special conditions	Flight strips	As necessary for the special conditions	Flight strips
<u>SUPPORTING FUNCTIONS</u>				
Turn on/off equip. and lights	Field and lighting conditions	Switches and pots	Activate switches or pots	Switches and pots
BRITE controls	Awareness of lighting conditions	Switches and pots	Activate switches or pots	Switches and pots
Monitor landing aids	Awareness of proper functioning	Landing aid monitors	Inform pilots of outages. Change runways if necessary	Radio, landing aids on/off switches

The number and names of positions vary somewhat from tower to tower. However, every tower has a Local Control, a Ground Control, and either a Clearance Delivery or a Flight Data position, often both. In addition, some kind of supervisory position is manned. Additional positions may be found at large airports. The exact allocation of functions to the positions will vary with the workload and airport configuration. However, the generalizations of the following sections are adequately representative for the purposes of this analysis.

#### 4.4.2 Local Control (LC)

This position controls all airborne operations in the terminal area (generally within a radius of five miles and below 3,000 feet altitude). The position controls takeoffs and landings and the movement of arriving aircraft on the ground until clear of active runways. LC issues clearances to takeoff and land, issues commands for maintaining safe separation of aircraft airborne and on the ground near active runways, relays pertinent information on weather and local conditions using V/UHF radio facilities. At appropriate times, LC hands-off aircraft to other controllers. LC also determines, selects and controls approach, runway, and taxiway lights, operates controls for special equipment (such as BRITE displays), monitors the status of landing aids, and marks flight strips as required. In emergencies, LC must ascertain the condition of equipment and personnel in an aircraft experiencing an emergency, determine the pilots's intentions, and issue appropriate commands to other aircraft.

#### 4.4.3 Ground Control (CG)

This position controls the movement of aircraft on the ground between the runways and the terminal gates and of emergency and service vehicles on taxiways and inactive runways. GC must coordinate with LC when a taxiing aircraft must cross an active runway. GC selects taxiing routes, issues appropriate commands to taxiing aircraft, and relays weather and field conditions to the aircraft via V/UHF radio. GC may clear itinerant aircraft for takeoff when

no conflict with LC would occur. GC marks flight progress strips as required. GC receives the handoffs of arriving aircraft from LC and receives departing aircraft from Clearance Delivery (CD) or Flight Data (FD), handing-off to LC.

#### 4.4.4 Clearance Delivery (CD)

This position delivers instrument clearances and related data to departing aircraft by V/UHF radio, and may relay local and route information as required. CD receives clearance information from FD and marks flight progress strips as required. CD hands off departing aircraft to GC. CD assumes the duties of FD when that position is not manned.

#### 4.4.5 Flight Data (FD)

This position generally acquires and prepares the data needed at the other positions. FD receives flight plan data from the ARTCC via intercom or FDEP, prepares and/or marks flight progress strips as required, records ATIS information on voice tapes, posts and disseminates other operational data as required, relays pilot reports to appropriate agencies, and maintains required records. In some towers, FD is responsible for making, recording, and disseminating hourly weather observations. FD may operate approach, runway, and taxiway lights on order of LC. FD assumes the duties of CD when that position is not manned.

#### 4.4.6 Supervisor

Responsibility for the entire operation of the tower cab must be assigned to a single person. Such a supervisor may bear one of a number of titles, such as Tower Supervisor, Team Supervisor, or Cab Coordinator. In the absence of a Supervisor, one of the controllers is designated Controller in Charge. Regardless of the title, a supervisory function is recognized, and a supervisor's position is identified in every tower. The Supervisor oversees all activities of the cab, provides the necessary assistance and decisions in operational situations, maintains proper discipline and conduct, and assures that official procedures and policies are carried out. The Supervisor assigns team personnel to the various positions and manages their rotation through positions. The Supervisor

(with LC) selects the runways to be used, determines when lights are required, monitors and controls the status of equipment and supplies, and maintains coordination of cab operations with the TRACON or ARTCC. This position monitors weather data and local conditions and assures that the ATIS tape is prepared and the new ATIS letter is disseminated. In emergencies, the Supervisor coordinates with appropriate agencies (such as fire, rescue, police, and other services). The Supervisor may stand in as temporary relief at any of the controller positions.

#### 4.4.7 Other Positions and Consolidated Positions

Depending on the nature of operations and workload, individual towers may provide additional positions to assist the basic functions. Operation of a position may be divided between two controllers, based on airport layout (North Local Control and South Local Control) or operational factors (Arrival Ground Control and Departure Ground Control). Sometimes, the duties of a position are shared with an assistant (Assistant Local Control, Local Control Coordinator, Local Sequencer). Sometimes, special positions are established for operational conditions that place too great a burden on the Local Controller (Helicopter Control, Satellite Control, Skyway Control) or Clearance Delivery (Gate Hold).

The number and nature of authorized positions varies from tower to tower, although the fundamental positions (Local Control, Ground Control, and Clearance Delivery/Flight Data) are always represented. Table 4.4-2 shows the authorized positions for 21 towers on which data were available. Obviously, there is no "typical" tower.

Often, in quiet periods, some authorized positions are not manned. All functions are accomplished by consolidating positions, that is, by assigning the functions of two or more positions to a single controller. The most common consolidations are Local Control with Ground Control and Clearance Delivery with Flight Data; however, numerous other combinations are used depending on the demands of the particular operations.

TABLE 4.4-2 EXAMPLES OF AUTHORIZED TOWER POSITIONS

AIRPORT	DATE OF REPORT	FDEP	FD	CD	CD/GH	GC1	GC2	LC1	LC2	LS	LCord	HELIO	A/LC1	A/LC2	CC	Team S	Twr S
BAL	9/75		X	X		X		X		X					X		
CLE	12/75		X	X		X		X									
DEN	1/76				X	X		X	X							X	
DTW	9/75		X	X		X		X							X	X	
DET	9/75		X			X		X									
HNL	11/75		X	X		X		X							X	X	
IAH	6/75		X	X		X		X								X	
JAX	8/75		X	X		X		X								X	
MCI	6/75			X		X		X							X		
LAS	1/76			X		X		X							X		
MIA	8/75		X	X		X	X	X	X								
MSY	6/75		<	>		X		X									
SNA	10/75	X	X	X		X		X	X			X					
PHL	12/75		X	X		X		X					X				X
PHX	1/76		<	>		X		X	X		X						X
STL	6/75	X	X	X		X	X	X	X						X		
SJU	1/76		<	>		X		X							X		
TPA	6/75		<	>		X		X									X
DCA	9/75		X	X		X		X				X	X		X		
YIP	9/75			X		X		X									
PIT	12/75		X	Z		X		X					X				X

BAL = BALTIMORE

CLE = CLEVELAND

DEN = DENVER

DET = DETROIT/CITY

DTW = DETROIT/METRO

HNL = HONOLULU

IAH = HOUSTON

JAX = JACKSONVILLE

MCI = KANSAS CITY

LAS = LAS VEGAS

MIA = MIAMI

MSY = NEW ORLEANS

SNA = SANTA ANA/ORANGE COUNTY

PHL = PHILADELPHIA

PHX = PHOENIX

STL = SAINT LOUIS

SJU = SAN JUAN

TPA = TAMPA

DCA = WASHINGTON NATIONAL

YIP = DETROIT/WILLOW RUN

PIT = PITTSBURG

FDEP = FLT DATA ENTRY POSITION

FD = FLIGHT DATA

CD = CLEARANCE DELIVERY

CD/GH = CLEARANCE DELIVERY/GATE HOLD

GD = GROUND CONTROL

LC = LOCAL CONTROL

LS = LOCAL SEQUENCER

LCord = LOCAL COORDINATOR

< > = FD& CD POSITIONS  
COMBINED

Z = CD IN TRACON

HELIO = HELICOPTER CONTROL

A/LC = ASSISTANT LOCAL CONTROL

CC = CAB COORDINATOR

TEAM S = TEAM SUPERVISOR

TWR S = TOWER SUPERVISOR

In many towers, extra locations (in the sense of work spaces in the tower) are set up to accommodate changes in the area of interest. For example, LC may occupy Location No. 1 when arrivals are mostly from the west. On another day, with different winds and arrivals from the east, LC will work from location No. 2.

#### 4.4.8 TRACAB Positions

A step in the cab growth cycle from the VFR tower to the TRACON/Tower Cab involves installation of airport surveillance radar (ASR) but not a radar room in the tower (see Section 2.2.5). In these so-called TRACABS, two radar control positions have been added to the tower cab: Approach Control (AC) and Departure Control (DC). These controllers are responsible for IFR aircraft and special traffic between the area of Local Control and that of Enroute Control at the ARTCC (generally between 5 miles and 30 miles from the airport). Approach Control receives handoffs from the ARTCC or adjacent Terminal Facility, issues air traffic control instructions, clearances and radar vectors to separate inbound aircraft, contacts DC to coordinate sequencing of inbound and outbound traffic, relays information on weather and local conditions as necessary, marks flight progress strips as required, and hands off to LC. The DC position performs essentially the same functions for outbound aircraft.

#### 4.4.9 Summary

With the exception of TRACABS, airport control tower positions are alike in that all have Local Control, Ground Control, and Clearance Delivery Flight Data positions. They differ in the exact number and types of authorized positions, special variations on the basic positions, and the ways that positions are consolidated to meet varying operational demands.

Although no "typical" operation can be described, the following general description (derived from observations at three airports) is offered as representative of many tower operations.

Despite differences in job titles, there is little difference in the way operations are performed, and these differences are

largely a function of the runway configuration. For example, in terms of duties, the Local Sequencer position is equivalent to Assistant Local Control or Local Coordinator in that they organize and arrange flight strips for the Local Controller. Similarly, the Cab Coordinator is equivalent to Team Supervisor and to Tower Supervisor, although there may be some difference in grade level for these various positions.

The Flight Data position is responsible for tearing off flight strips as they are printed, inserting them in plastic holders and delivering them to the Clearance Delivery position (CD). In the absence of a letter of agreement authorizing clearance on receipt of the flight strip, the CD calls the ARTCC for clearance. Upon pilot request, CD reads the clearance and the pilot repeats it to confirm correct receipt. CD then initials the strip and passes it along to Ground Control (GC). Upon receipt of a request from an aircraft for pushback, GC issues taxi instruction, checking with Local Control (LC) if there is a need to cross an active runway. Control is passed over to LC for clearance to enter to the runway to be used for takeoff and the flight strip is passed along to the LC position where it is arranged in the takeoff flight strip holder. Assistant LC also communicates with TRACON for information on arrivals; these flight strips are prepared by hand and include only the aircraft ID and assigned runway and are arranged in landing sequence for use by LC and later GC.

Every hour, the Cab Supervisor collects all used flight strips and records the traffic count by aircraft category. He also directs rotation of positions, mealtime schedules, and exchange of personnel between cab and TRACON. Cab duty is normally limited to four hours, but since there are usually more TRACON than cab personnel, not all personnel man a cab position on every day.

These descriptions of the major functions performed at positions permit the correlation of the detailed functions of Section 4.2 with the basic tower positions. This has been done in Table 4.4-3. In the table, for each function an 'X' has been entered under each tower position where that function is usually performed. Entries in two or more positions may mean the function is performed

TABLE 4.4-3. ALLOCATION OF FUNCTIONS TO POSITIONS IN FAA CONTROL TOWERS

FUNCTIONS	Local Control	Ground Control	Clearance Delivery	Flight Data	Supervisor
<u>CONTROL AIRCRAFT</u>					
<u>Clearances</u>					
To pushback		X			
To taxi	X	X			
To take off	X				
To land	X				
To cross runway/taxiway	X	X			
<u>Commands</u>					
Hold	X	X			
Yield	X	X			
Report back	X	X	X		
Change frequency	X	X	X		
Contact	X	X	X		
Resume taxiing	X	X			
Execute missed approach	X				
Squawk	X				
Taxi route	X	X			
Headings and turns	X				
Altitude	X				
Speed	X	X			
Emergency instructions	X	X			
<u>Queries</u>					
Identification	X	X			
Location	X	X			
Destination	X	X	X		
Intentions	X	X	X		
Traffic in vicinity of A/C	X	X	X		
Emergency Information	X	X	X		

TABLE 4.4-3. ALLOCATION OF FUNCTIONS TO POSITIONS IN FAA CONTROL TOWERS (CONTINUED)

FUNCTION	Local Control	Ground Control	Clearance Delivery	Flight Data	Supervisor
<u>RELAY INFORMATION</u>					
<u>Flight Clearance Data to A/C</u>					
Cleared as filed			X	X	
Changes in clearance	X	X	X	X	
Beacon assignment	X	X	X	X	
Contact frequency	X	X	X		
Restrictions	X		X	X	X
Runway/taxiway assignments	X	X	X	X	X
<u>Local Conditions</u>					
Weather	X	X	X	X	X
RVR, RVV	X	X		X	X
Vortex, wind shear data	X	X		X	X
NOTAMS	X	X	X	X	X
Altimeter setting	X	X		X	X
Runway in use	X	X		X	X
Runway condition	X	X		X	X
Restrictions	X	X	X	X	X
Traffic	X	X			
ATIS in effect	X	X	X	X	X
<u>Notification, to or from</u>					
Other tower personnel	X	X	X	X	X
TRACON	X			X	X
ART JC, FSS	X			X	X
Other airport operations, local	X	X	X	X	X
Other airports				X	X
Emergency contacts	X	X	X	X	X

TABLE 4.4-3. ALLOCATION OF FUNCTIONS TO POSITIONS IN FAA CONTROL TOWERS (CONTINUED)

FUNCTION	Local Control	Ground Control	Clearance Delivery	Flight Data	Supervisor
<u>RECORD INFORMATION</u>					
<u>Time of</u>					
Takeoff	X				
Landing	X				
Missed approach	X				
Clearance delivery			X		
Gate delivery		X	X		
<u>Check</u>					
Clearance Delivered			X	X	
Beacon assigned			X	X	
Hardoff completed		X	X		
Clearance validated				X	
<u>Data</u>					
Beacon assigned			X		
Other flight strip data	X	X	X		
Gate assigned		X	X		
Traffic count	X		X	X	X
ATIS generation				X	X
<u>SUPPORT</u>					
Turn on/off equipment/lights	X	X			X
BRITE controls	X	X			
Monitoring landing aids	X	X		X	X

at all indicated positions or that it is performed at one position in some towers, at another position in other towers. In either case, design of a working position should allow for access to all equipment necessary to perform the checked functions.

#### 4.5 ALLOCATION OF EQUIPMENT TO TOWER POSITIONS

##### 4.5.1 Some Basic Equipment Packages

In Section 4.3, the equipment required and currently used was identified for each function that has to be performed in a control tower (Table 4-1). In Section 4.4, the allocation of functions to control tower positions was explained and summarized in Table 4-3. By combining this information, it is possible to deduce what kinds of equipment should be at each tower position. However, because there is great inter-tower variability both in the authorization of positions and in the assignment of functions to positions, there is no standard equipment package for each position.

Some basic generalities can be established. Every position must communicate freely with other facilities and organizations, so practically every position has a telephone (telco) package, including a handset, a dial, a keypack for selecting frequently called extensions, and a speaker. Similarly, for intercommunications within the ATC system, every position has the FAA keypack and speaker. Every position also has a microphone and a microphone switch. The requirement for recording the exact time of many transactions requires a digital clock at nearly every position. This package of equipment is so basic that, to save repetition, it will be referred to as Basic 1.

Positions requiring direct contact with aircraft (LC, GC, CD) must have V/UHF radio equipment - a transmitter selector panel, a receiver selector panel, radio controls, and a speaker. These positions also require flight strips, strip holders and a rack. There is enough generality here to warrant labeling this package as Basic 2.

Positions which control aircraft movement are generally required to relay weather information and local conditions, generating a need for an altimeter setting indicator, wind speed and wind

direction indicators, and indicators and controls for RVR, RVV, and other visibility instruments when available. These positions sometimes, although rarely, use the signal light gun. In some towers, aircraft operational activity is recorded by pressing a mechanical counter for each transaction; so, when used, counters would be at the positions controlling aircraft movement. This package of equipment has been designated Basic 3.

There are some additional control and monitoring devices that are generally grouped together for use by the supervisor or one of the controllers, usually between designated position locations. These include the switches for control of runway, approach, taxiway, VASE, REIL, cab, and any other lights requiring centralized control. Where available, monitoring and control equipment for DME, VOR and ILS systems are generally located near the light switch panels. This package of controls and indicators will be referred to as Basic 4.

#### 4.5.2 Types of Towers

Specialized equipment in tower cabs reflects the type of operations delegated to the tower. So a breakdown of operational tower types is useful for categorizing tower equipment. For this purpose we will consider the following types: VFR tower, tower with approach control but no radar, tower with radar approach control (TRACAB), and the cab/TRACON combination with ARTS II or ARTS III facilities.

#### 4.5.3 VFR Tower

The VFR tower generally will contain the Basic 1 package at all positions; in addition, Basic 2 and 3 at LC, GC, and CD, and Basic 4 near the LC position, possibly between LC and GC. When available, FD will also have the FDEP printer and keyboard, the equipment for making ATIS tape recordings, and an Electrowriter or Telautograph for weather and information on local conditions. Some VFR towers are responsible for taking limited weather observations (LAWRS); in these towers, there may be a ceilometer indicator at the FD position. The supervisor, in addition to Basic 1, may have special telephones to fire, search and rescue, Coast Guard, and

similar operations. Controls for cab heating, ventilation and air conditioning may also be located near the supervisor.

#### 4.5.4 Tower-No Radar, Approach Control

Where a tower has an approach control function but no radar, an Approach Control position may be added, but the equipment is the same as in Section 4.5.3, since control is exercised via VHF radio.

#### 4.5.5 Tower With Radar Approach Control - TRACAB and Cab/TRACON

With ASR added, the Radar Approach Control and Departure Control positions may be established in the tower cab, constituting a TRACAB (see Section 4.4.8). Each of these positions, which may be consolidated when operations are light, will require the Basic 1 and 2 packages. In addition, each position will have a panel of switches for selecting those sets of beacon codes which will be displayed to that position, and a BRITE radar display with its information is also made available to the LC and GC via BRITE equipment. At this level of operation, LC or GC may also have a small television monitor as backup for the BRITE, and sometimes special closed-circuit low-light-level television (LLTV) to fill in visual coverage of areas not clearly visible from the windows.

If the positions of AC and DC are located in a separate radar room (TRACON), the cab equipment of this cab/TRACON combination is the same as the TRACAB less AC and DC.

#### 4.5.6 Cab/TRACON - ARTS II and ARTS III

With the ARTS II or III systems, the principal difference in cab operations is that the BRITE displays now show a data tag giving aircraft identification for each transponder-equipped aircraft under control and altitude for those aircraft equipped to transmit altitude data. Cab equipment includes that described in Section 4.5.5 plus an ARTS keypack with PEM or trackball at the FD position, used primarily for acquiring beacon code assignments from the ARTS computer. FD may also use the keypack to enter the latest ATIS letter and altimeter setting for display on the BRITE monitors and will sometimes have a small commercial television monitor to preview these entries.

A few airports are now equipped with ground surveillance radar (ASDE) to assist LC and GC in the control of aircraft on the ground when visibility is poor. The ASDE picture is displayed on BRITE equipment. The ASDE-BRITE may constitute additional equipment at the GC or LC positions. In some towers, a selector switch permits either ASDE or ASR data to be displayed on the same BRITE.

#### 4.5.7 Summary

Four basic packages of equipment can be used to describe much of the equipment allocated to the various tower positions. The addition of aids for the various controllers results in additional controls and displays at their positions. These allocations are summarized in Table 4.4-4. Table 4.4-4 summarizes the basic packages, and shows the allocation of equipment to tower position for various operational types of towers.

### 4.6 LAYOUT OF EQUIPMENT IN TOWER CABS

#### 4.6.1 Special Characteristics of the Tower Environment

Control towers as a class differ basically from other ATC facilities in a number of ways that have significance for the design and layout of equipment for the occupants. Unlike ATC personnel working in other facilities, control tower operators are usually in visual contact with the aircraft under their control. They work surrounded by windows through which they can see as much of the ramps, taxiways, runways, and approach zones over which aircraft will move as the airport configuration will permit. Conditions adversely affecting visibility create the requirements for some of the upgrading subsystems under consideration. In these cases the aim is to augment or supplement visual contact - not to replace it. This is an important point to keep in mind when evaluating the impact of proposed systems - direct visual contact will be retained and, when suitable, will very likely be the primary mode for receiving the information used in making control judgements.

TABLE 4.4-4 ALLOCATION OF EQUIPMENT TO POSITIONS IN FAA  
CONTROL TOWERS

a. BASIC ALLOCATIONS

Basic 1

Clock  
Telco Dial  
Telco Keypack  
Telco Handset  
Telco Speakers  
FAA Keypack  
FAA Speakers  
Headset  
Microphone  
Microphone Switch

Basic 2

Flight Strips, strip Holders and Rack  
Radio Transmitter Selector Panel  
Radio Receiver Selector Panel  
Radio Controls  
Radio Speakers

Basic 3

Wind Speed Indicator  
Wind Direction Indicator  
Altimeter Setting Indicator  
RVR Indicators and Controls  
RVV Indicators and Controls  
Signal Light Gun  
Mechanical Counter

Basic 4

Runway Lights Panel  
Approach Lights Panel  
Taxiway Lights Panel  
VASI, REIL, Special Lights  
DME, VOR, ILS Monitor and Control Equipment  
Tower Cab Lights



Tower controllers generally have a wide area of activities to cover. In order to see clearly, they frequently will walk to the window nearest an area of concern. This need for mobility is mainly characteristic of tower operators; in radar rooms each controller is more closely locked into a fixed position. Thus, in the tower, the term, "position", often does not imply a fixed duty location but rather a set of duties-- an important point to keep in mind in analyzing the location and arrangement of equipment.

To permit mobility and to increase the area of ground in view, tower controllers frequently work standing up. Thus basic displays and controls must be compatible with standing operation.

Because of the windows, the level of ambient illumination can vary considerably with external illumination and is often much higher than in windowless radar rooms. Thus glare on instrument faces and the level of adaptation of controllers' vision pose special problems for the design of tower equipment. The need to leave windows unobscured limits the area within which equipment can be mounted.

#### 4.6.2 Factors Affecting Layout

The arrangement of equipment in control tower cabs is affected by the following factors: operational positions authorized, size and shape of cab, amount and type of equipment, layout of airport, flow of information, orientation of tower, and local preferences.

Generally a set of the equipment shown in Table 4.4-4 will be installed at or near the location in the cab designated for each authorized position. However, the total amount of equipment can be less if two adjacent positions share some equipment (such as a BRITE display, or a Basic 2 package). On the other hand, we have already noted that some towers equip two positions but man only one, resulting in more equipment than would be predicted from Table 4.4-4. Moreover, the nature of operations will dictate different pieces of equipment for the same position in different towers. For example, a tower where weather observations are made (LAWRS) might add a ceilometer indicator at FD; a tower having

ASDE might have an extra BRITE display at GC, or a tower responsible for numerous satellite airports might have several electro-writers at FD to receive their weather observations.

The authorized equipment must be fitted into the space available. Control towers have various shapes (square, rectangular, pentagonal, hexagonal, octagonal, or circular) and sizes. Floor areas range from 200 to over 500 square feet. Although bigger towers are generally made available for larger operations, there is no standard ratio of equipment to space. Generally, if equipment is installed along the walls of a tower, about half of the floor space is used. Often, equipment islands occupy additional space. Nearly always an entry stairway uses floor space. The remaining "movement space" can be as little as 90 square feet (Phoenix's hexagonal tower).

Changes in operational equipment at an airport will generally result in the addition of equipment in the tower cab. If ASR is installed, the tower will add BRITE displays and control panels for LC positions, possibly for GC. In the case of conversion to a TRACAB, two additional control positions are added, with associated consoles and displays. If the TRACAB is later changed to a TRACON, these positions and equipment will, of course, be removed to another location.

The principal determinant of the location of operational positions within the tower cab is the layout of the airport. LC's must be able to see all runways; GC's must be able to see taxiways and ramps. If runways lie on opposite sides of the tower, multiple LC positions may be required. Extensive terminal areas and taxiways may require multiple GC positions. Once the LC and GC positions are established, there are more options for locating the other positions, but stairways and special equipment still pose additional constraints.

If other conditions permit, the orientation of the tower can influence equipment layout. It is desirable to mount visual displays, particularly CRT scopes (such as BRITE) so that they do not receive direct sunlight with the consequent glare on faceplates. This means avoiding placement of scopes facing the southern windows.

The flow of information in the cab, particularly the routing of flight progress strips, is another major influence on the location of operating positions. The sequence of positions FD-CD-GC-LC is often found in tower layouts.

Finally, since the layout of the cab is at the discretion of local officials, the personal preferences of the people who happen to take part in the design process will add such considerations (often irrelevant) as symmetry, esthetics, and familiarity with some particular layout.

The arrangement of individual pieces, modules, and blocks of equipment within panels is nearly as variable as the location of positions. Two adjacent panels, containing the same basic equipment, may have very different arrangements. Sometimes there is a good operational reason (such as the need for one person to operate two panels in consolidated operations); sometimes the design results from a personal whim.

#### 4.6.3 Examples of Cab Layouts

It is evident from the preceding discussion that assignment of equipment to positions, allocation of space for positions, and arrangement of equipment within positions all vary considerably from tower-to-tower. Standard layouts do not exist, and, in view of the dependence of equipment layout on airport layout, they are probably undesirable (see Section 4.7.1). In describing a "baseline" tower, then, we shall proceed as follows: a) describe two pairs of towers of similar operational workload, b) describe two special towers (the world's busiest and a small TRACAB), and c) describe a proposed layout for a high-activity level tower based on the combined judgements of human factors specialists and experienced controllers. General conclusions may be drawn from these illustrations.

4.6.3.1 Pittsburgh and Miami - In 1975 Greater Pittsburgh International Airport handled 285,165 aircraft operations; Miami International Airport, 265,463. Figure 4.6-1 shows the relationship of

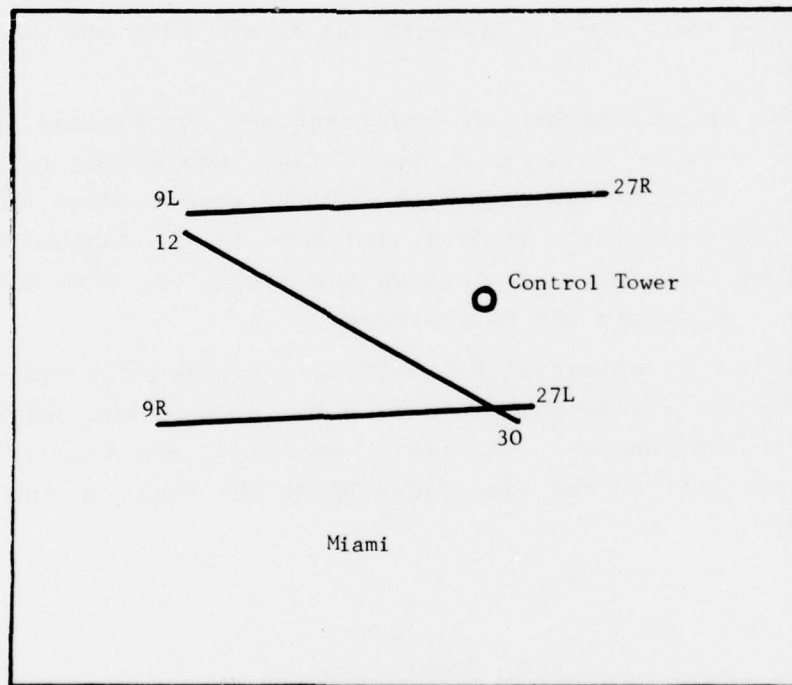
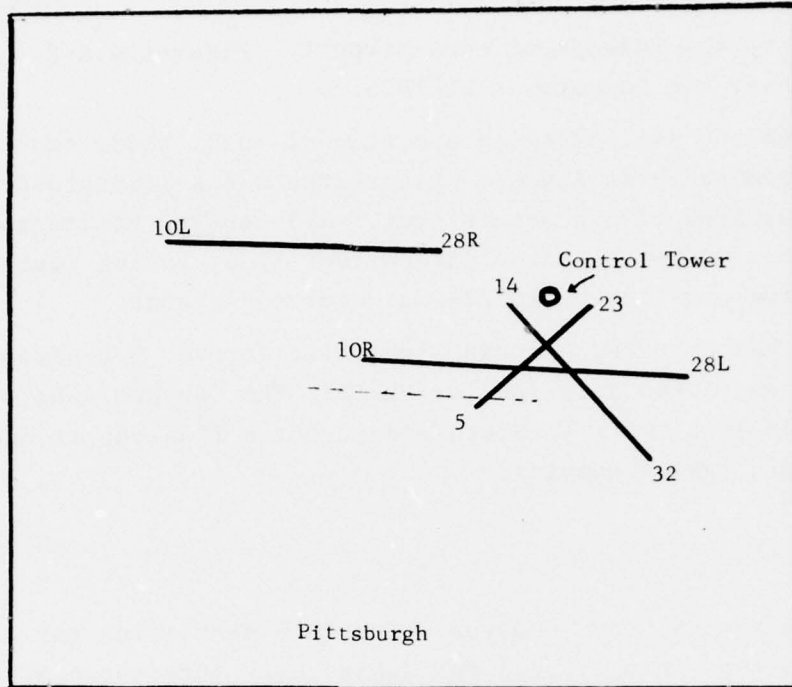

FIGURE 4.6-1. AIRPORT LAYOUTS, PITTSBURGH AND MIAMI

the towers to the runways at each airport. Figures 4.6-2 and 4.6.-3 show the tower cab layouts as of 1975.

Despite the similarity in operational load, these two towers differ considerably in layout. Pittsburgh has a rectangular cab with a floor area of 288 square feet. All control positions are arranged in a row along one eighteen-foot side, facing south. This configuration puts runway 10L/28R at everyone's back.

Miami has an octagonal cab with a little over 300 square feet, permitting an island location for FD/CD. The Cab Coordinator position faces west, with LC-South and LC-North flanking it and facing the main runway complex.

4.6.3.2 Kansas City and Houston - The 1975 statistics for aircraft operations were 176,248 for Kansas City International Airport, 192,953 for Houston Intercontinental Airport. Figure 4.6-4 shows the airport configurations for both locations; Figure 4.6-5 and 4.6-6 show the tower cab layouts for Kansas City and Houston respectively.

Again we see different cab configurations for similar operational loads. Kansas City has a square cab, twenty feet to a side. The runways lie to the west and south of the tower. Here the CD and FD positions have been located centrally at the southwest corner flanked directly by a south GC and a west GC, with a south LC and a west LC beyond the GC positions.

Houston has a pentagonal cab with an estimated 420 square feet of area. The controller positions face the apex of the angle formed by the two runways. The two LC positions are side-by-side, with GC to the left on the same side, FD to the right on the adjacent side.



BEST AVAILABLE COPY

- 1 CLOCK
- 2 WIND DIRECTION
- 3 WIND SPEED
- 4 WIND FORCE
- 5 WIND VIBRATION INDICATOR
- 6 MAP CONTROL'S CONTROL
- 7 RS MONITOR W/NOISE
- 8A TELCO POSITION SPEAKER
- 8B CALL DIRECTOR
- 9A CALL DIRECTOR
- 10A 12 CHANNEL FAA RADIO
- 10B TELCO/FAA RADIO
- 10C 4 CHANNEL FAA RADIO
- 10D
- 10E
- 10F
- 11A TELCO 3 OVA RETRAX SE KEY
- 11B
- 12 TELCO ATTN JACKS RECESSED
- 13 TELCO 30A EAL
- 14 ATIS STATUS INDICATOR
- 15 ATIS STATUS INDICATOR
- 16 AUDIO STATUS UNIT 12
- 17 U.S. STATUS CONTROL UNIT
- 18 DIMMER CONTROL LIGHTS
- 19 FOLP
- 20 DEEP KEYBOARD
- 21 TELETYPE TERMINAL
- 22 MOTOR CONTROL UNIT
- 23 BRITISH CONTROL
- 23A INDICATOR
- 24 ARTIS KEYTRACK
- 25 TEMPORARY BRITISH SELECTOR SWITCHES
- 26 BRITISH SELECTOR SWITCHES
- 27 CRASH POSITION BY DC PA
- 28 FIELD LIGHTING
- 29 ALS CONTROL
- 30 F/P STIMP HOLDER BAY
- 31 INST LIGHTING TEMP
- 32 WATER COOLER
- 33
- 34 LC OVERRIDE SPEAKER (FAA)

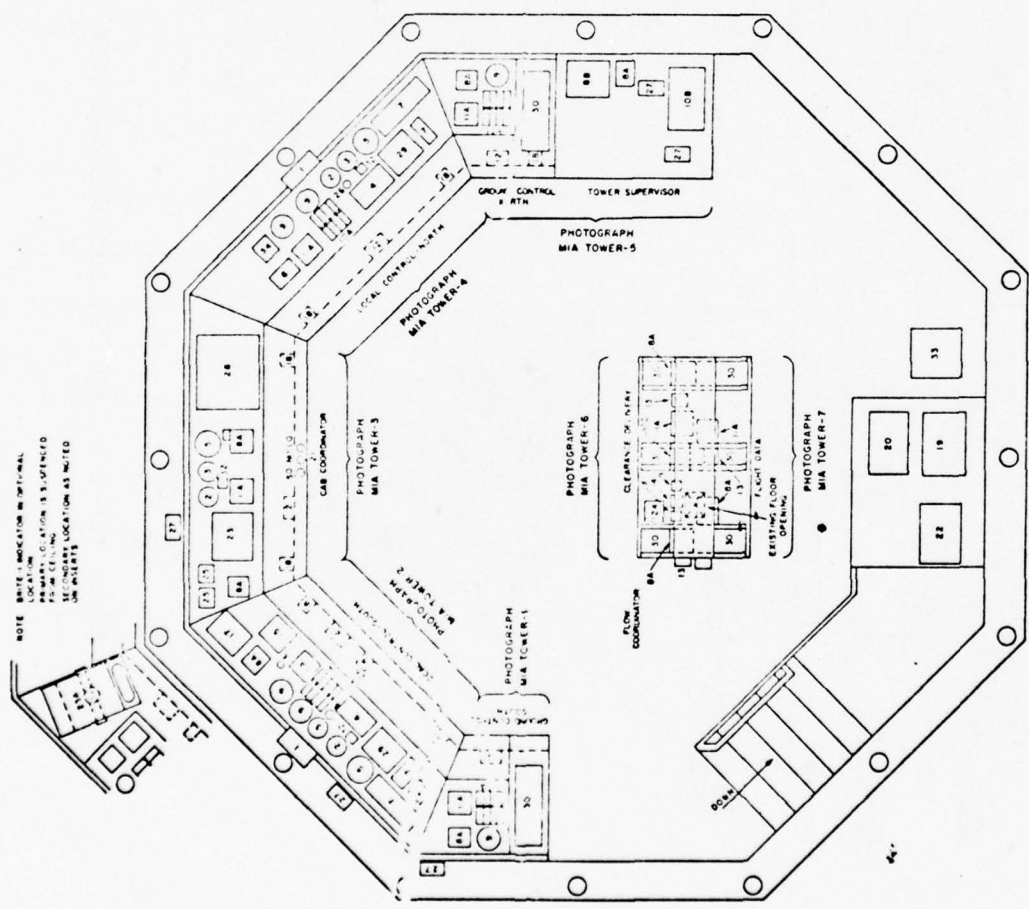

FIGURE 4.6-3. LAYOUT OF MIAMI TOWER

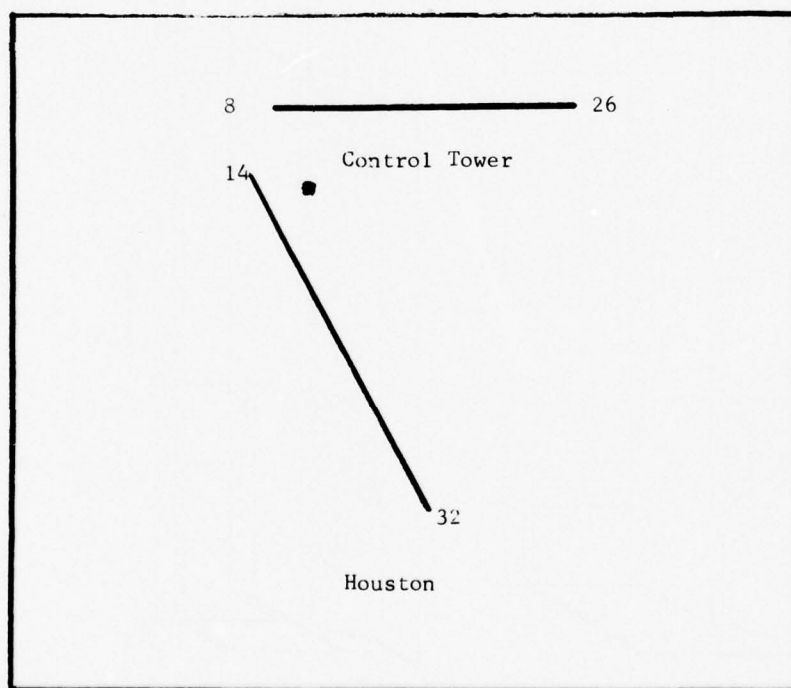
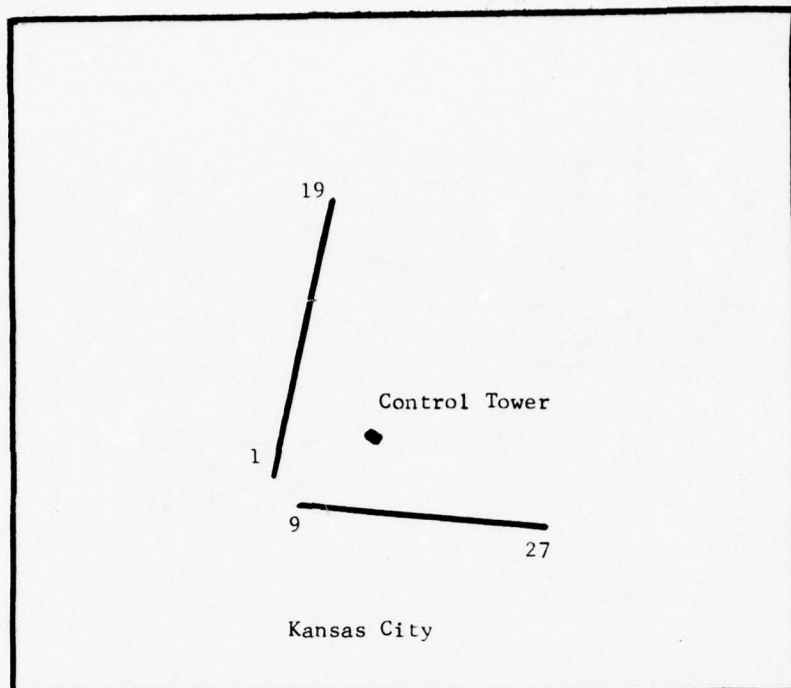
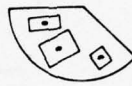
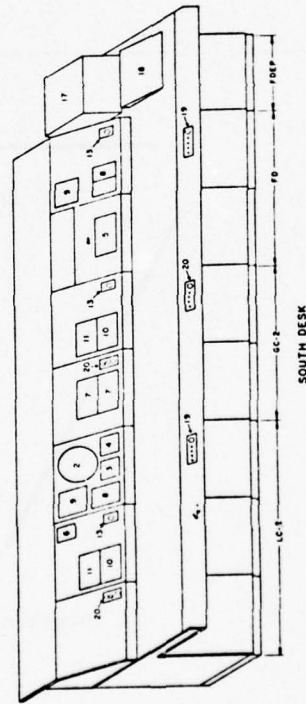
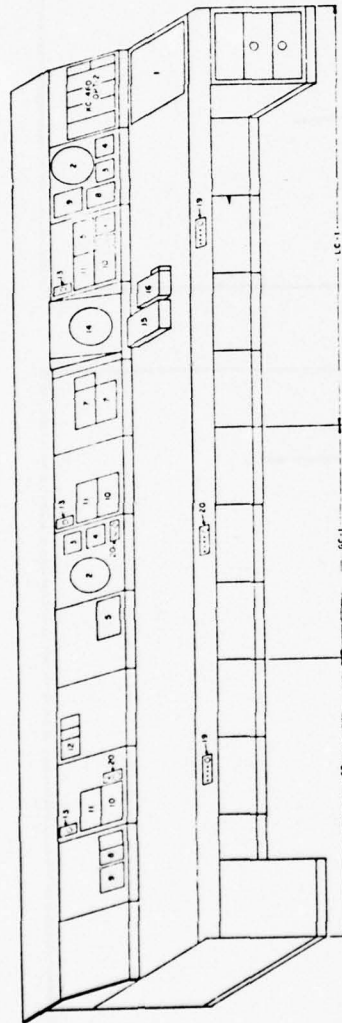
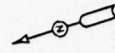

FIGURE 4.6-4. AIRPORT LAYOUTS, KANSAS CITY AND HOUSTON

BEST AVAILABLE COPY

- 1 FIELD LIGHTING CONTROL PANEL
- 2 TELESCOPE
- 3 WIND DIRECTION
- 4 WIND VELOCITY
- 5 CLOCK
- 6 COMMUNICATION LIGHT
- 7 COMMUNICATION RANGE (RVR) INDICATOR
- 8 TELESCOPE KEYBOARD AND DIAL
- 9 TELESCOPE SPEAKER
- 10 TELESCOPE SELECTOR UNIT AND VOLUME CONTROL
- 11 PAIR SWITCHES
- 12 ATIS CONTROL PANEL
- 13 OVERHEAD LIGHT CONTROL
- 14 TELESCOPE
- 15 BRITISH ALPHA NUMERIC CONTROL PANEL
- 16 BRITISH KEYBOARD
- 17 TELESCOPE
- 18 TELESCOPE KEYBOARD
- 19 TELESCOPE JACKS
- 20 PAIR JACKS



PLATFORM OVER STAIRWAY

FIGURE 4.6-5. LAYOUT OF KANSAS CITY TOWER

- 1 TVR SELECTOR UNIT (FUTURE)
- 2 FAA SPEAKER
- 3 TELCO (30) REBOARD
- 4 TELCO SPEAKER
- 5 TELCO DIAL
- 6 TELCO INDICATOR
- 7 WIND VEL INDICATOR
- 8 ALTIMETER
- 9 WHITE DISPLAY PANEL (FUTURE)
- 10 A/FM CONTROL PANEL (FUTURE ONLY)
- 11 BEACON CONTROL PANEL (FUTURE)
- 12 A/FM CONTROL PANEL (FUTURE ONLY)
- 13 A/FM KEYBOARD
- 14 Muting Panel
- 15 RVR READOUT (FUTURE)
- 16 RVR CONTROL PANEL (FUTURE)
- 17 RVR CONTROL PANEL (FUTURE ONLY)
- 18 RVR CONTROL PANEL (FUTURE ONLY)
- 19 RVR CONTROL PANEL (FUTURE ONLY)
- 20 RVR CONTROL PANEL (FUTURE ONLY)
- 21 STEEL LIGHTING PANEL
- 22 DIMMER FOR OUTRIGGED LIGHT
- 23 STEEL LIGHTING PANEL
- 24 STEEL LIGHTING PANEL
- 25 INTERCOM SYSTEM CONTROL
- 26 MONITOR PANEL FOR PHONE
- 27 MONITOR PANEL FOR PHONE
- 28 LAND LINE PHONE
- 29 TELCO HOT LINE
- 30 TIME P.A.M. UNIT
- 31 TELETYPE UNIT
- 32 TOGGLE SWITCH FOR WAITE
- 33 FOR P. HETZEL (FUTURE)
- 34 TELETYPE UNIT (FUTURE)
- 35 TELETYPE UNIT
- 36 TELETYPE UNIT
- 37 ATIS CONTROL BY
- 38 I/O MONITOR PANEL
- 39 ENG O/I MONITOR
- 40 I/O MONITOR PANEL
- 41 TOWER INDICATOR
- 42 VHF TRANSMITTER
- 43 VHF TRANSMITTER
- 44 LIGHT CLEANER
- 45 WINDOW WASHER
- 46 WINDOW WASHER
- 47 WINDOW WASHER
- 48 WINDOW WASHER
- 49 WINDOW WASHER
- 50 TELCO JACK
- 51 FAA JACK
- 52 PHELY STORAGE
- 53 PHELY STORAGE
- 54 CD PACKUP
- 55 CD PACKUP
- 56 CD PACKUP
- 57 CD PACKUP
- 58 CD PACKUP
- 59 CD PACKUP
- 60 CD PACKUP
- 61 CD PACKUP
- 62 CD PACKUP
- 63 CD PACKUP
- 64 CD PACKUP
- 65 CD PACKUP
- 66 CD PACKUP
- 67 CD PACKUP
- 68 CD PACKUP
- 69 CD PACKUP
- 70 CD PACKUP
- 71 CD PACKUP
- 72 CD PACKUP
- 73 CD PACKUP
- 74 CD PACKUP
- 75 CD PACKUP
- 76 CD PACKUP
- 77 CD PACKUP
- 78 CD PACKUP
- 79 CD PACKUP
- 80 CD PACKUP
- 81 CD PACKUP
- 82 CD PACKUP
- 83 CD PACKUP
- 84 CD PACKUP
- 85 CD PACKUP
- 86 CD PACKUP
- 87 CD PACKUP
- 88 CD PACKUP
- 89 CD PACKUP
- 90 CD PACKUP
- 91 CD PACKUP
- 92 CD PACKUP
- 93 CD PACKUP
- 94 CD PACKUP
- 95 CD PACKUP
- 96 CD PACKUP
- 97 CD PACKUP
- 98 CD PACKUP
- 99 CD PACKUP
- 100 CD PACKUP

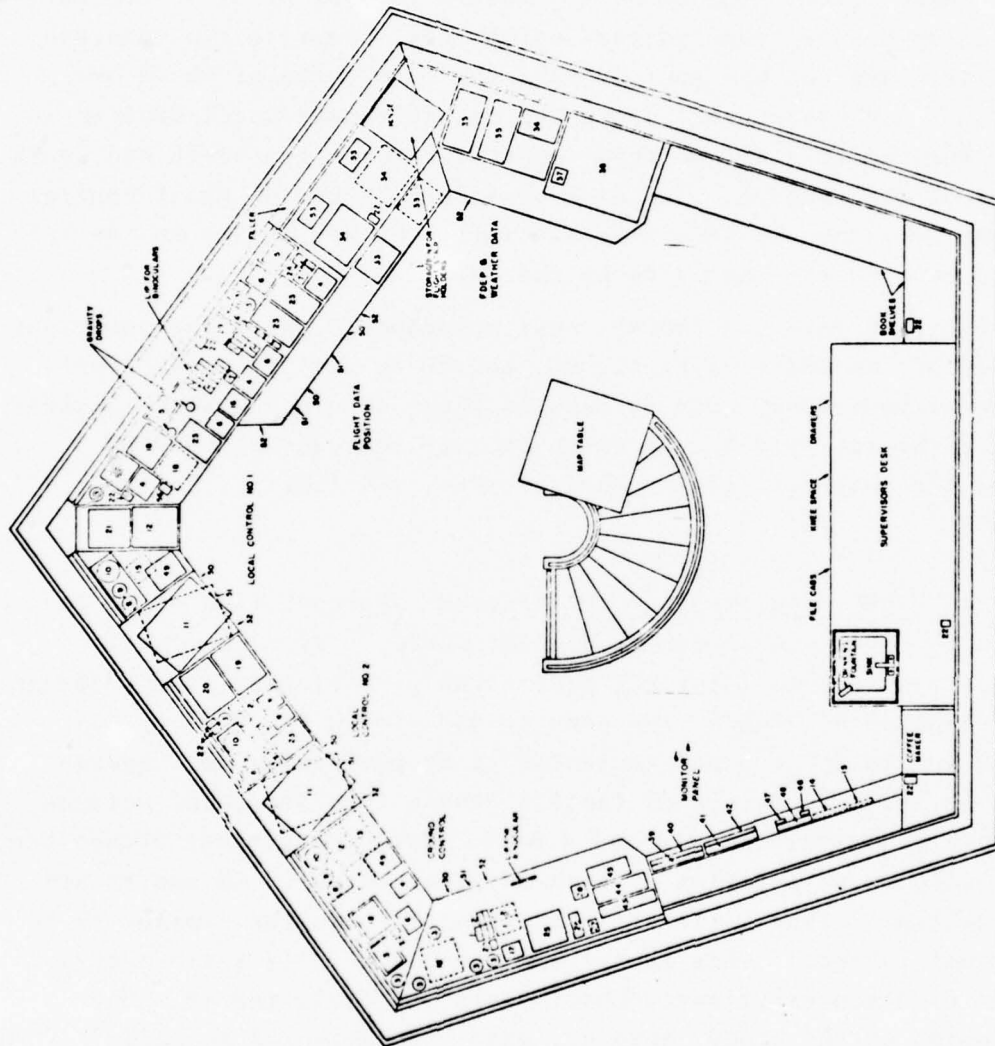

FIGURE 4.6-6. LAYOUT OF HOUSTON TOWER

4.6.3.3 O'Hare and Portland (Maine) - The towers at Chicago's O'Hare International Airport and Portland International Jetport are the same shape (pentagons), but differ greatly in layout because of operational differences. O'Hare, one of the world's busiest airports, handled 668,368 aircraft operations in 1975. Portland, a VFR airport with a TRACAB, handled 104,900 operations. Figure 4.6-7 shows the airport layouts, and Figures 4.6-8 and 4.6-9 show the O'Hare and Portland cabs respectively.

O'Hare tower, with about 420 square feet of area, is centrally located amid seven runways that essentially comprise two separate airports. The cab has four LC positions, only two of which are manned at any given time, depending on the runway configuration in use. The two LC's divide their control between the north and south halves of the airport. Two side-by-side GC's divide their control between arriving and departing aircraft. CD and FD are to the left of the GC's on the same side of the cab.

Portland tower, a TRACAB, must accommodate two radar positions (AC and DC) in addition to LC, GC, and FD in its 350 square feet. The radar positions, with FD between them, are in an island backed against the stairway in the north half of the cab. LC and GC occupy the southwest and southeast sides, overlooking the two runways.

4.6.3.4 NAFEC Experimental Cab - Another approach to a model layout is an experimental cab studied at NAFEC.<sup>8</sup> Two air traffic control specialists (ATCS's), a research psychologist, and a design team composed of ATCS's from nine of the eleven FAA Regions designed an "ideal" cab and evaluated it by performing mock operations in it. The layout of the 525 square-foot irregular octagon is shown in Figures 4.6-10 and 4.6-11. Two GC positions occupy one side, with an LC position at each adjacent corner. CD and FD are on a central island. (It is interesting to note the similarity to the Miami layout.) This layout was found generally satisfactory by the eighteen experienced controllers who evaluated it. One conclusion of the study, however, was: "Location of specific

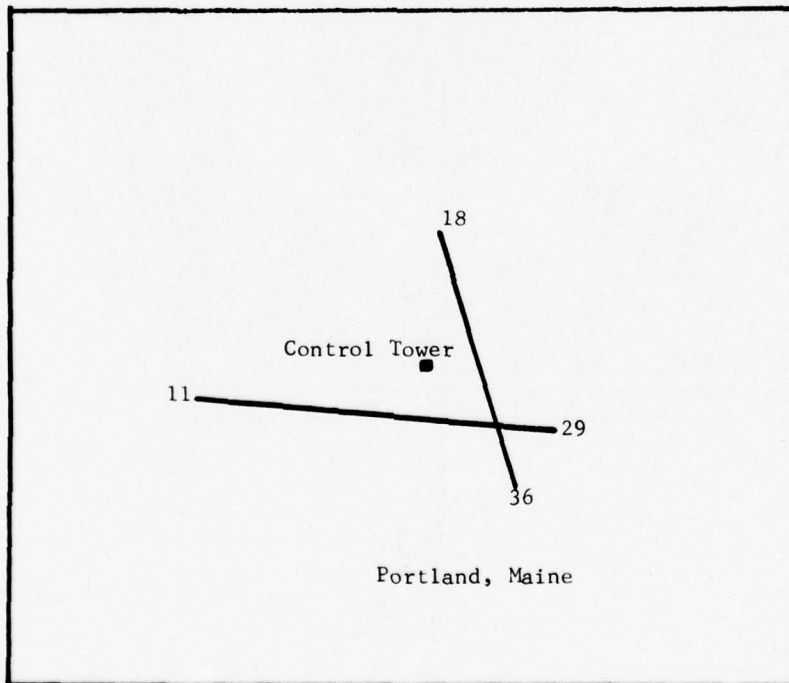
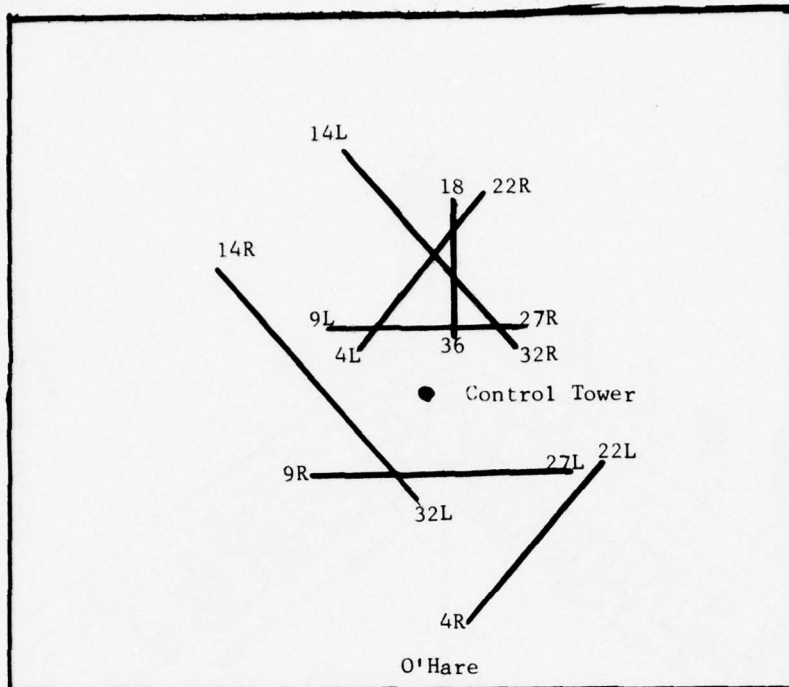

FIGURE 4.6-7. AIRPORT LAYOUTS, O'HARE AND PORTLAND

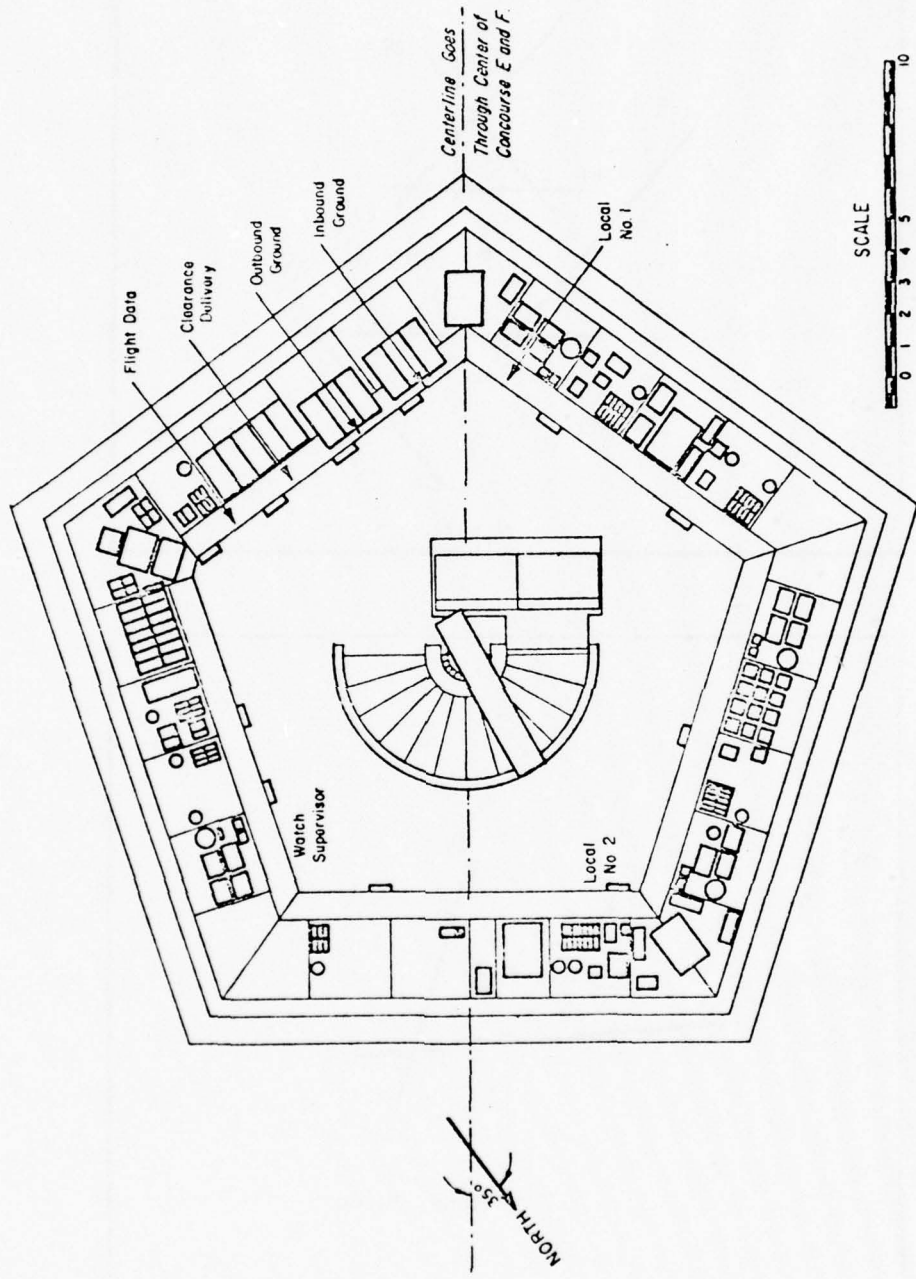

FIGURE 4.6-8. LAYOUT OF O'HARE TOWER

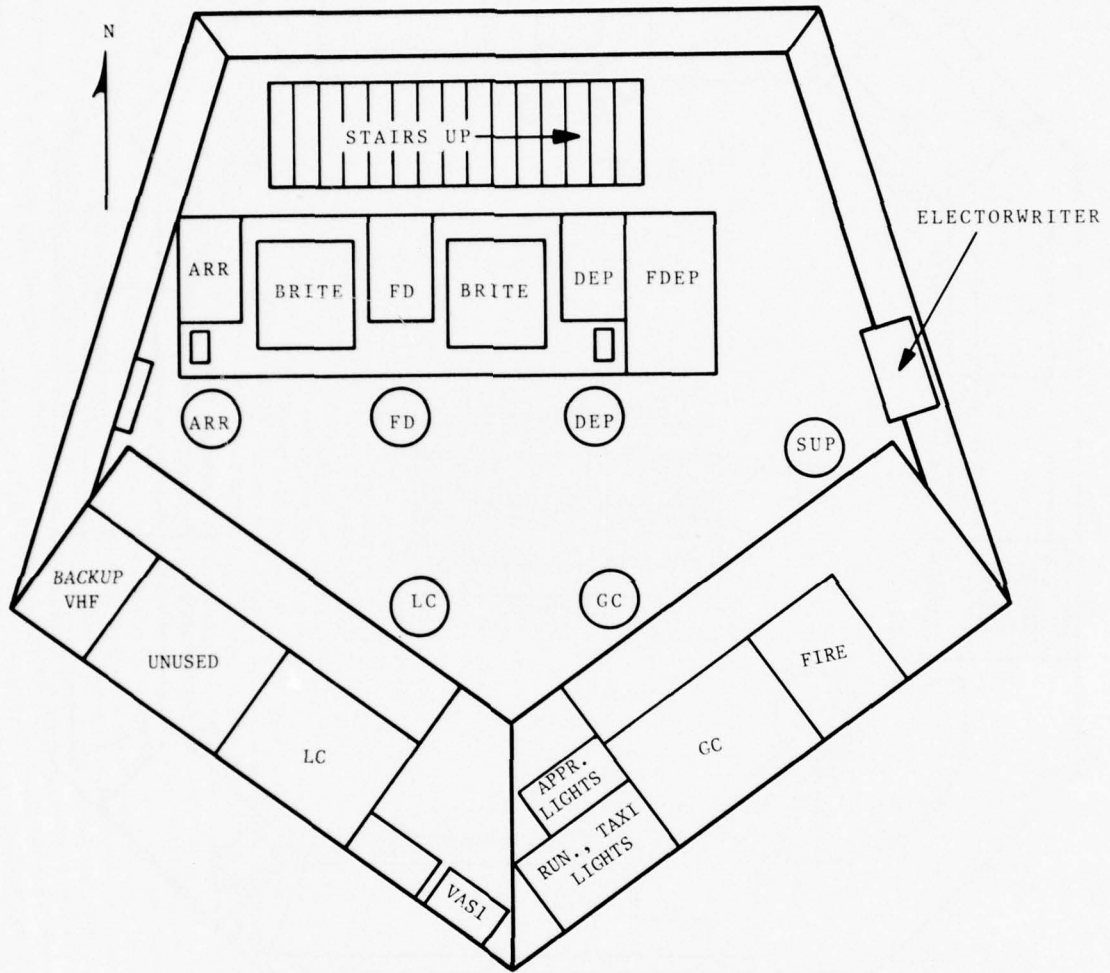

FIGURE 4.6-9. LAYOUT OF PORTLAND, MAINE, TRACAB

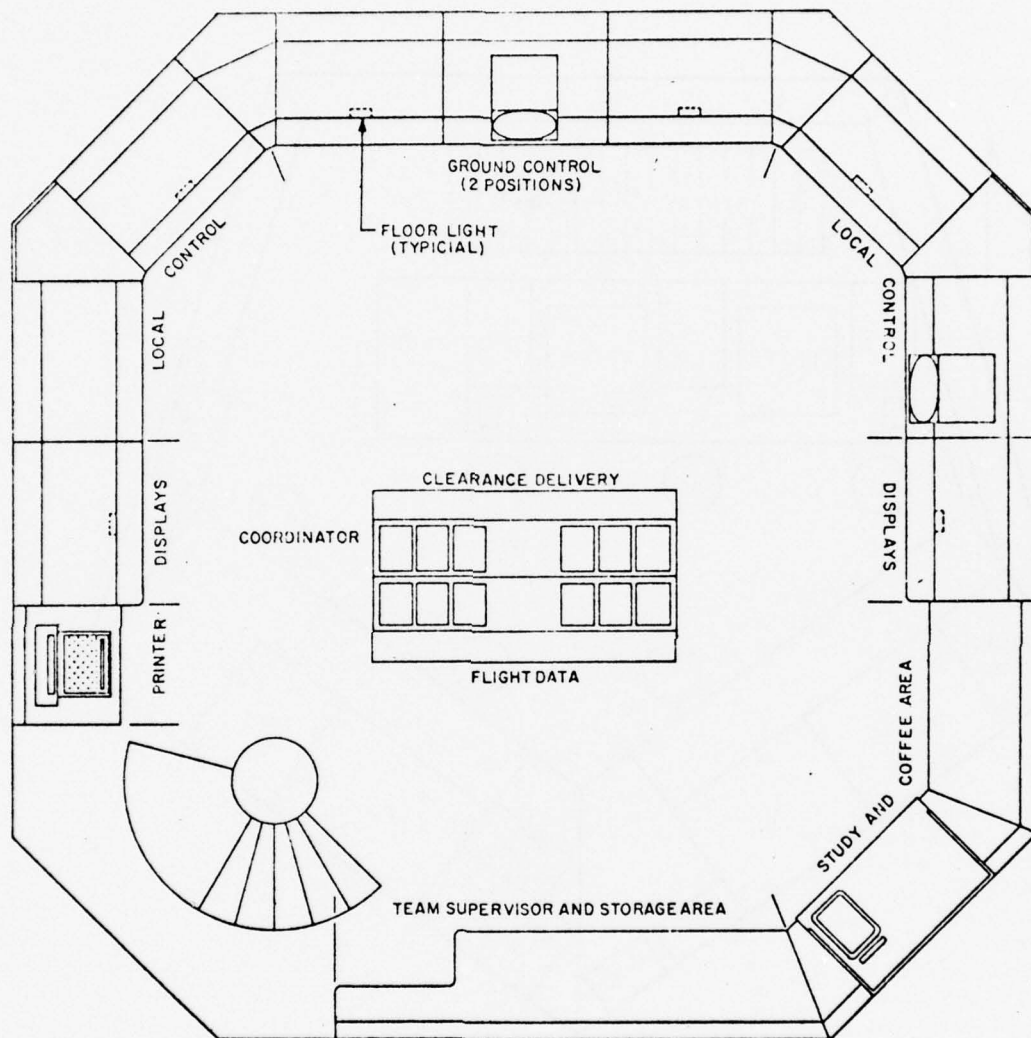

FIGURE 4.6-10. LAYOUT OF NAFFC CAB MOCKUP



FIGURE 4.6-11. NAFEC CAB MOCKUP

equipments in the console and the relationship of respective operating positions vary in accordance with individual facility requirements."

4.6.3.5 Arrangement of Instruments in Panels - The assignment of instrument groups to positions was addressed in Section 4.5. The preceding figures have illustrated some of the variety of ways in which instruments and controls common to various positions have been arranged on the instrument panels. Panel layouts must not only be convenient for the position operator; they must be compatible with consolidated operations. So the local pattern of position layout and the consolidation conventions act together to force unique layouts for individual cabs. The NAFEC experiments included a local control panel design (Figure 4.6-12) and a modified design (Figure 4.6-13) that permits the sharing of some instruments with ground control. If one seeks a model layout, these arrangements are as good as any available. However, even here we find differences in panel groupings of telco and radio controls between two adjacent positions (Figure 4.6-12).

#### 4.7 CURRENT PERCEIVED PROBLEMS

##### 4.7.1 Standardization vs. Flexibility

The tradeoff between standardization and flexibility in the arrangement of control tower cab equipment is essentially one of economic vs. operational advantages. The economic advantages of standardization derive from lower prices for equipment, consoles, and panels designed once and bought in quantity. However, the necessity to arrange cab equipment in a configuration that relates to the individual layout of the airport and the operational constraints associated with position consolidation would seem to outweigh the advantages of standardization. At the level of layout of instruments on panels, perhaps a standard pattern could be adopted for what we have called the Basic 1, 2, and 3 equipment packages. The recommendations of the NAFEC study are the best guidelines we have found for such a standard. Nevertheless, we must anticipate



FIGURE 4.6-12. FULL INSTRUMENT PANEL

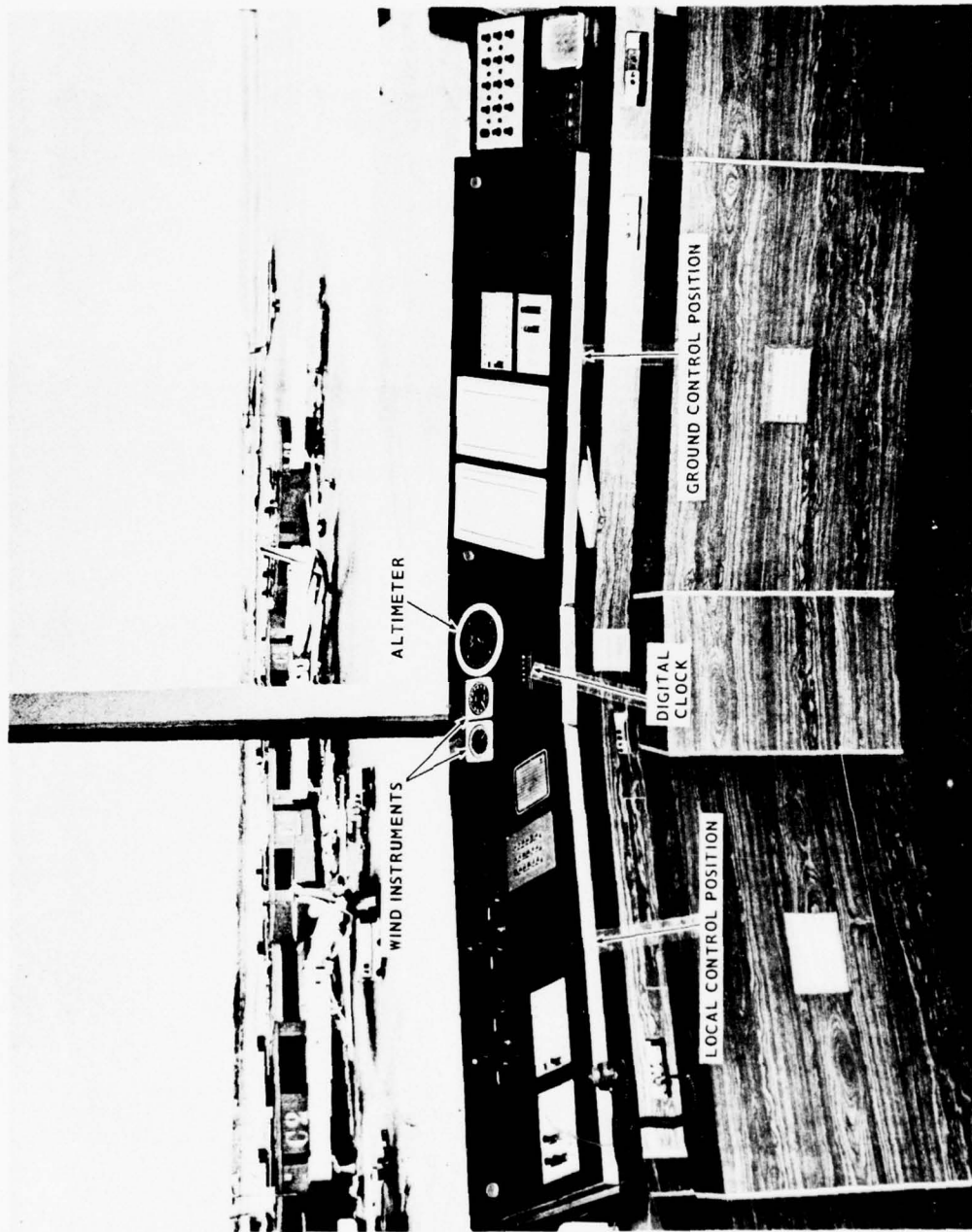

FIGURE 4.6-13. MODIFIED INSTRUMENT PANEL

that the placement of new equipment in cabs resulting from adoption of UG3RD systems will require planning based on each cab's unique configuration.

#### 4.7.2 Operational vs. Administrative Duties

The principal area where administrative duties are imposed on controllers is in record keeping, particularly in marking flight progress strips. There is a danger that, because of the administrative convenience, such requirements can gradually proliferate. In principle, it is undesirable to require the LC and GC positions to maintain records beyond those they need to maintain control of the aircraft under their jurisdiction. Additional record keeping can be a burden and a distraction from the primary functions when traffic is heavy and operating conditions are unfavorable. In line with this principle, upgraded tower equipment related to data management should have as an objective the capability to assume those data recording duties now assigned to controllers. Also, when new systems (such as UG3RD systems) bring data into the cab that should be relayed to other locations (such as the weather net), care must be taken to automate this relay function rather than to add it to a controller's duties.

#### 4.7.3 Need for Integration of Equipment

There is a possibility that each UG3RD system will develop an independent set of displays for tower use and the selection and tuning controls associated with them. Often, these new devices will augment rather than replace the older equipment. Such proliferation of equipment can become a burden to control tower operators and take up valuable space. An area worthy of special concentration, then, is the study of ways to integrate the outputs of some of these systems onto common display surfaces.

A second consideration is the compatibility of information presentation as new displays are introduced. Two modes of presentation of data may be equally good, but when both must be used interchangeably, there may be conflict and confusion. During transition periods, new equipment will be used together with the

old, creating an even greater need for compatibility. For example, a controller cycling between an old PPI in the radar room and a new display in the tower should be able to estimate aircraft separation and arrival rates at a glance from both displays, necessitating compatibility in orientation and conventions of display symbols.

#### 4.7.4 Controller Workload

Workload varies considerably from tower to tower and from time-to-time in a given tower. When workload is light, economy can be effected by consolidating working positions. When workload is heavy, however, it can not be relieved simply by adding manpower, because the additional requirements for coordination between controllers become a burden in themselves. It has been shown that systems operated by people do not suddenly break down at a predictable saturation load. Rather, the people adapt to the load by simplifying procedures, especially by dropping low priority tasks.<sup>9</sup> A hidden consequence of this process is an increase in risk of accidents. If accidents are a low frequency phenomenon (as in ATC), then this risk does not become apparent until an accident occurs. For example, it was concluded that a principal cause of a serious accident at O'Hare<sup>10</sup> was the failure of GC to add one letter to the designation of a holding area, resulting in confusion as to the location of a taxiing aircraft and collision with another aircraft taking off. In the six minutes preceding the abbreviated message, the controller served seven flights, involving 29 radio transmissions - an average of one transmission every 12 seconds. Transcriptions of other transmissions show that such message abbreviation is not uncommon in busy periods.

Simple counts of aircraft served or transmissions made are not adequate measures for predicting when an increase in workload will create enough stress to force streamlining of procedures, nor when the streamlining reaches a dangerous level. A more detailed analysis of the factors relating workload to operational safety is desirable as a basis for estimating realistically the impact of new equipment on tower procedures and the safety of operations.

#### REFERENCES SECTION 4

1. Noll, R.B., Scully, J.J., Simpson, R.W., and Zvara, J., "Analysis of Terminal Air Traffic Controller Functions," U.S. DOT, Transportation Systems Center, Cambridge, MA, Rep. No. DOT-TSC-103-71-1, May 1971.
2. D'Allessandro, F., Heiser, W., Knights, G., et. al., "Airport Surface Traffic Control Concept Formulation Study: Volume II - Operations Analysis of O'Hare Airport - Part 1," U.S. DOT, Federal Aviation Administration, Washington, DC, Rep. No. FAA-RD-75-120.II, July 1975.
3. Morse, S., "The Worst Job In The World?", Yankee, Dec.1976,82-87.
4. Martindale,D., "Sweaty Palms In The Control Tower," Psychology Today, February 1977, 71-75.
5. "Terminal Facility Configuration and Data Survey," U.S. DOT, Federal Aviation Administration, NAFEC, Washington, D.C.:  
Baltimore, Rep. No. FAA-NA-75-155, September 1975  
Cleveland, Rep. No. FAA-NA-75-193, December 1975  
Denver, Rep. No. FAA-NA-76-151, January 1976  
Detroit, Rep. No. FAA-NA-75-176, September 1975  
Honolulu, Rep. No. FAA-NA-75-185, November 1975  
Houston, Rep. No. FAA-NA-75-166, June 1975  
Jacksonville, Rep. No. FAA-NA-75-171, August 1975  
Kansas City, Rep. No. FAA-NA-75-169, June 1975  
Las Vegas, Rep. No. FAA-NA-75-188, January 1976  
Miami, Rep. No. FAA-NA-75-172, August 1975  
New Orleans, Rep. No. FAA-NA-75-167, June 1975  
Orange County, Rep. No. FAA-NA-75-179, October 1975  
Philadelphia, Rep. No. FAA-NA-75-187, December 1975  
Phoenix, Rep. No. FAA-NA-75-190, January 1976  
Pittsburgh, Rep. No. FAA-NA-75-55, September 1975  
St. Louis, Rep. No. FAA-NA-75-161, June 1975  
San Juan, Rep. No. FAA-NA-75-184, October 1975

#### REFERENCES FOR SECTION 4 (CONT'D)

Tampa, Rep. No. FAA-NA-75-164, June 1975

Washington, DC, Rep. No. FAA-NA-75-175, September 1975

6. "Air Traffic Control," U.S. DOT, Federal Aviation Administration, Washington DC, Handbook 7110.65, January 1976.
7. "Position Classification Standards," U.S. Civil Service Commission, Washington, DC, Standard TS75, GS-2152, Part II, July 1968, 26-27.
8. Bradley, R.J., Jr., "Evaluation of High-Activity Level Tower Cab," U.S. DOT, Federal Aviation Administration, Rep. No. FAA-RD-72-111, October 1972.
9. Parsons, H.M., Man-Machine System Experiments, Johns Hopkins Press, Baltimore, MD. 1972, 546-548.

## 5. CURRENT TOWER-RELATED SYSTEMS AND PROCEDURES

### 5.1 AIRSPACE SURVEILLANCE DATA IN THE TOWER

#### 5.1.1 System Overview

The primary responsibilities of Local Control in the cab are as follows:

- a. Assuring safe runway utilization by clearing successive arrivals and intermixed arrivals and departures. Operations can extend to combinations of runways. Responsibility can extend to initial departure vectoring.
- b. Sequencing VFR arrivals and VFR arrivals with IFR arrivals which are making a visual approach and have been handed off by approach control.
- c. Providing initial separation of IFR departure from IFR arrivals and IFR departures.
- d. Providing separation advisories to VFR traffic once traffic has been visually acquired.
- e. Coordinating the above functions with the rest of the terminal/airport control elements during runway configuration changes.

In a VFR cab this is the only responsibility of the cab with regard to airspace control. Surveillance is entirely visual. IFR departure separation is assured by controlling interdeparture timing and initial heading vectors. If the cab is responsible for providing non-radar approach control, the approach and departure controllers will use pilot position reports from IFR traffic to sequence and separate the traffic.

When non-radar approach control was extended to radar approach control in the cab, the display system used was based on the standard Plan Position Indicator (PPI).

Due to the nature of a PPI, the image of a target is bright only while illuminated by the antenna. Once the antenna beam has passed beyond the target, the image begins to fade until swept the next time around. PPI's, therefore, tend to be of non-uniform brightness and generally dim. The original PPI displays in the cab were installed with a hood into which the controller had to look. The use of the hood made other approach control functions (e.g., record keeping) difficult, and eventually the approach control function was moved to a separate low ambient light level room, the TRACON.

While the PPI was in the cab the hood could be removed at night so that Local Control could share the display, the hood, however, precluded his use of the display during the day when traffic was busiest. Therefore, the loss of the PPI had a minor effect on Local Control. Without radar information, Local Control frequently has visibility problems. In haze and at night Local Control can have difficulty visually acquiring aircraft even in VFR conditions, since VFR conditions are based upon the pilot's visibility not the controller's visibility.

Lack of visibility impacts on separation advisories. The visibility problem is compounded during hand-off from Approach Control to Local Control since at that time there can be a mix of tower controlled and approach controlled aircraft in close proximity. Detection of a potential collision may be difficult. On the one hand, Local Control may have trouble seeing any of the aircraft, and on the other hand, Approach Control does not have contact with the VFR aircraft. In addition, the VFR radar targets may be weak on the Approach Control display.

The controller's visibility problem becomes further aggravated as ceiling and pilot's visibility are reduced. Approach Control must retain control (and radio contact) until the pilot can see the airport or preceding traffic. As conditions deteriorate, IFR arrivals must approach closer to the airport before being seen from the cab. They can enter a confined VFR airspace rather abruptly, adversely affecting the cab's separation advisories.

The TV video scan-converted bright display system was developed in 1967, to alleviate the problems of poor visibility for Local Control.

System deployment began in 1968, and the first installations were in tower cabs located close to their associated approach control facility. Virtually all cabs co-located with a TRACON are now equipped with a bright display system.

The Bright Radar Indicator Tower Equipment (BRITE) consists of a small PPI, a TV camera focused on the PPI, and a high brightness and contrast TV display. The TV camera is furnished with a silicon coating on which the image decays slowly (i.e., the image "sticks"). The image does not fully decay during the time the antenna makes one rotation and hence the camera is left with a stored image which it can write repeatedly at a standard TV rate of 30 frames/second. This technique greatly increases the brightness of the display and permits its use in the high ambient light of the cab. The PPI and TV camera (contained in one rack of equipment) are generally located in the TRACON equipment room; the TV video is cabled (up to 300 feet) to the tower cab.

Local Control can use the radar information made available on the BRITE display as a VFR aid and, if radar qualified, can provide limited radar approach control for aircraft on final approach, initial departures, missed approaches (until handed off) and local traffic such as helicopters. The BRITE unit greatly enhances Local Control's effectiveness, especially at the outer reaches of his control responsibility and in dealing with hand-offs.

The advent of ARTS III with its provision for alphanumeric data blocks, motivated extension of the BRITE system to include Bright Alphanumeric Equipment which provided the cab with data blocks and an interface with the ARTS III system. The A/N equipment displays flight identity, barometric altitude, ground speed, and a variety of other optional information from the ARTS processor (some of which is site dependent). It also provides a key for cab interaction with the ARTS system.

A second extension of the basic BRITE system is the TV microwave Link (TML) used to remote the BRITE display to satellite airports located away from the approach control facility. The basic single channel (class A) TML consists of a PPI, TV camera (with "sticky" vidicon), a microwave transmitter/antenna, provisions for a repeater, a microwave receiver, and a BRITE display. This system provides only radar targets (primary and secondary) and does not provide alphanumeric. If alphanumeric data blocks were written on the PPI, the "sticky" vidicon would smear them making them illegible. For alphanumeric remoting from an ARTS site, a dual channel (class B) TML is required with a second PPI displaying the alphanumeric data, a second TV camera with a commercial (non-sticky) vidicon, and a video mixer for combining the radar and alphanumeric data video prior to transmission. The primary purpose of the remote BRITE is to aid the satellite airports in VFR sequencing and separation advisories. Radar separation of IFR traffic is not normally provided, since this is already provided by the TRACON. However, if the VFR tower operators are radar qualified and IFR traffic is heavy, limited radar approach control authority can be delegated from the TRACON as it is with the co-located cab. The establishment criteria for a remote BRITE in a VFR tower are now; a) more than 35,000 annual itinerant operations and b) tower within 20 miles of the associated TRACON. Under these criteria, approximately 100 satellite airports have or soon will have a remote BRITE display system.

With the advent of the BRITE system, it was no longer necessary for radar approach control to be located in a low ambient light level room (IFR room). At small, low IFR volume airports it became possible to install ASR/RBS and simply perform radar approach control from the cab. The control authority was termed TRACAB (as opposed to TRACON) and resulted in a less expensive means for providing radar approach control at towers newly qualified for IFR control. Approximately 39 TRACAB's have been established since 1968 providing radar service where it otherwise might not have been cost effective.

### 5.1.2 BRITE System

5.1.2.1 Background - Several series of BRITE systems have been developed and deployed since 1967. The first series (BRITE-1) involved the purchase of approximately 80 units. The system was primarily solid state and provided a small 12-inch diameter display. There are still some BRITE-1 units in operation although they are slowly being replaced with newer models. The second series (BRITE-2) of about 40 units was deployed in 1970. The unit was all solid state for increased reliability, had improved processing of the beacon video (secondary returns), and provided a 16-inch diameter display, the 12-inch having been found to be too small. The most recent series is the BRITE-4 (there is no BRITE-3). The first purchase was made in 1972 for 91 units. Subsequently an additional 186 units were ordered. The BRITE-4 has improved reliability, better resolution, and a digital azimuth interface for compatibility with the latest ASR's. Since the BRITE-2 is physically similar to BRITE-4, only the BRITE-4 will be described further in this section.

5.1.2.2 BRITE-4 Description\* - The BRITE is comprised of a TV display and remote control unit located in the cab and a small PPI TV camera and auxiliary equipment located in the radar equipment room. The components are shown in Figure 5.1-1. Contrast and brightness controls are available on the display and can also be remotely controlled. The display may be mounted overhead (hung from the cab ceiling) or in the controller console (see Figure 5.1-2).

The PPI on which the basic presentation is made is 5 inches in diameter with a sweep rate corresponding to that of the local ASR site (approximately 15 rpm). The PPI will operate on five discrete ranges\* selectable from the remote control head. Each range will display calibrated range marks. The sweep can be decentered by twice the selected range; 60 miles is the sweep range limit.

\*See Appendix A

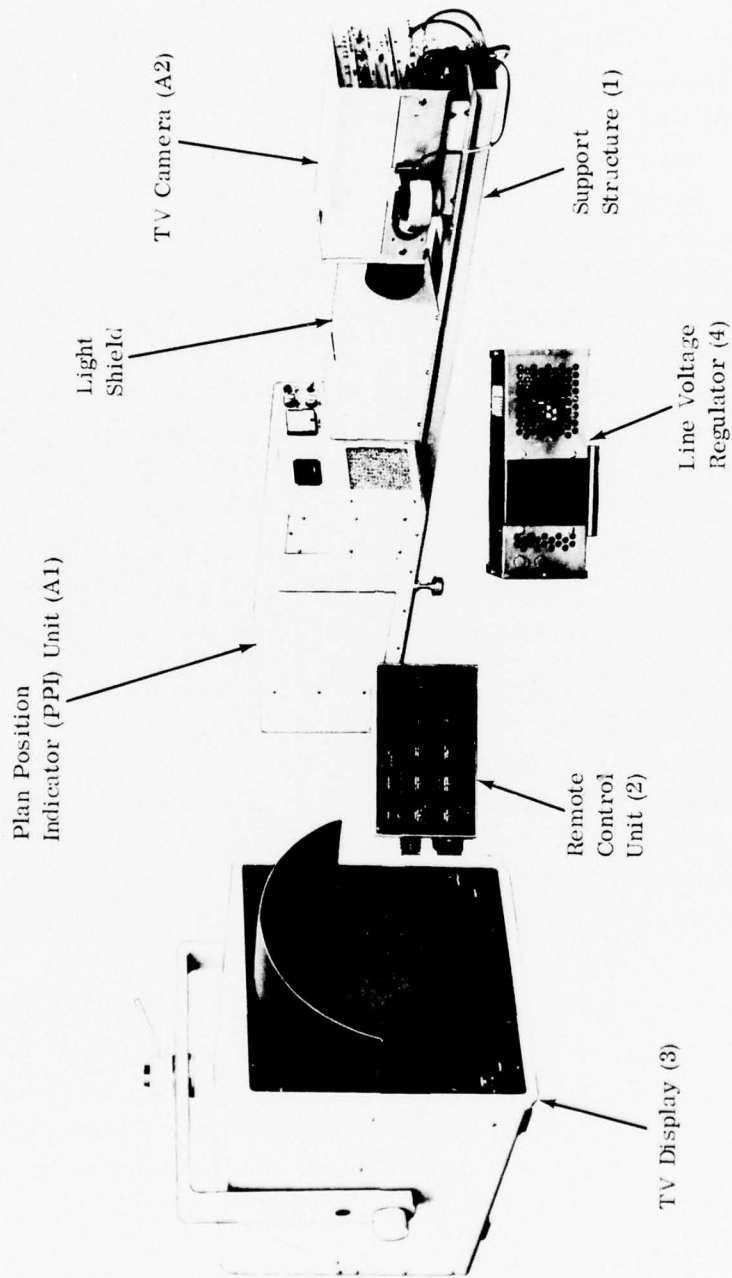

FIGURE 5.1-1. BRITE RADAR INDICATOR TOWER EQUIPMENT (BRITE-2)



FIGURE 5.1.1-2. BRITE DISPLAY HUNG OVERHEAD IN BOSTON LOGAN TOWER CAB

In addition to range marks, the unit can be furnished with a video mapper. This permits the drawing of a map of the airport and primary air routes to the various runways to aid in tracking targets and monitoring approaches.

The remote control head is designed to be operated either on a desk top or from a recess in a control console. The head is shown in Figure 5.1-3. The panel is illuminated (back light) for night use. The unit permits the independent brightness control of the video map (if present), the range marks, the beacon target return, and the primary target return. In addition, overall brightness and contrast can be remotely controlled. Also controlled from this panel are range and decentering (East-West and North-South).

#### 5.1.3 BRITE Alphanumeric Equipment Description

The BRITE alphanumeric equipment (A/N equipment) is intended for use with BRITE displays at cabs which are co-located with an ARTS III TRACON. The purposes of the equipment are (1) to accept BRITE TV video, (2) to interface with ARTS III to receive alphanumeric data for the appropriate targets, (3) to transmit required information to ARTS III for formatting the data, (4) to convert the alphanumeric data to TV video format, (5) to mix the alphanumeric TV video and BRITE TV video, and (6) to transmit the mixed video to the BRITE display. The equipment is composed of an ARTS III interface, a 5-inch diameter CRT for alphanumeric display, a TV camera with a low memory commercial vidicon synchronized with the BRITE camera for conversion to TV video, a video mixer, and several data entry devices.

The data entry devices are an alphanumeric display control panel with the BRITE remote control head, a keyboard, and position entry module (PEM). The equipment is shown in Figure 5.14.

The alphanumeric data to be displayed consist of: 1) data blocks (flight identity, barometric altitude, ground speed, etc.) associated with each target by a leader, 2) tabular lists of data on flights of special significance to the controller, 3) a preview

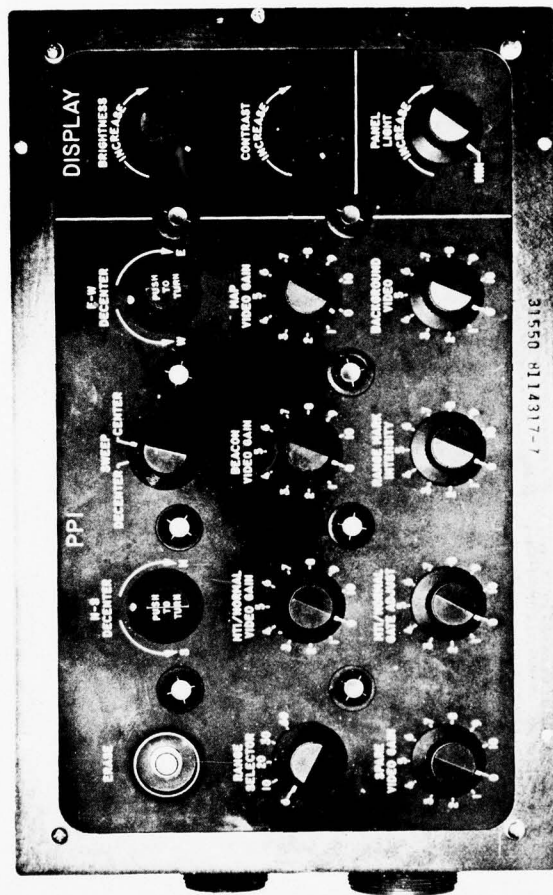
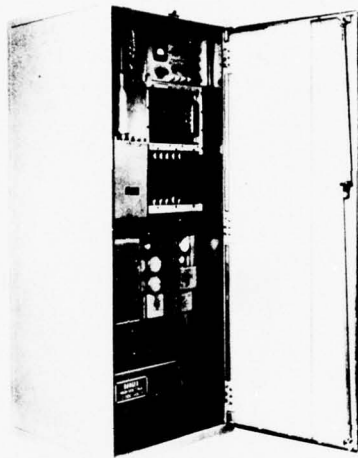

FIGURE 5.1-5. REMOTE CONTROL UNIT

BRITE A/N GENERATOR



BRITE  
A/N CONTROL  
PANEL



BRITE  
KEYBOARD



POSITION  
ENTRY  
MODULE



FIGURE 5.1-4. TOWER CAB MODIFICATION ILLUSTRATION OF COMPLETE EQUIPMENT

area in which recently keyed-in data is displayed prior to entering into the system, and (4) a system data area used to display utility data such as time of day, barometric reading, and the current ATIS identification letter. The preview area can also be used to display requested information from ARTS such as beacon code for a VFR aircraft at a TCA facility. A BRITE display with alphanumeric equipment at O'Hare is shown in Figure 5.1-5.

The common BRITE and A/N control panel, shown in Figure 5.1-6, has 5 toggle switches to permit selection of alphanumeric data from any of 5 presentations (i.e., take a "quick-look" at another controller's target data). This includes a presentation displaying data blocks on all beacon equipped targets. The unit has 6 field inhibit toggle switches permitting the controller to blank any or all fields within the data block (e.g., blank all fields such as ground speed leaving only flight identity). Also included is an alphanumeric video gain pot, an eight-position rotary switch for selecting the length of the leader to the data block and a three position rotary switch for selecting the size of the alphanumeric to be displayed. The size selected at most major airports is approximately 0.25 inches in height.

The keyboard assembly is an array of keyboard switches mounted in a console. The keyboard and PEM are shown in Figure 5.1-7. In using the keyboard, the controller can enter numerals 0 through 9, the 26 capital letters of the alphabet (set in alphabetical order), and five special symbols. In addition, several function keys are provided (e.g., to drop a track/data block, to initiate or accept handoff, to display track file in preview area, to relocate the preview area, etc.).

The PEM is a small unit attached to the keyboard. It contains a small joy stick and an enter button. The joy stick is used to slew a cursor to a point on the display (e.g., for locating the preview area, for locating targets for which information is requested or entered). Its use is similar to the track ball in the ARTS III TRACON consoles.

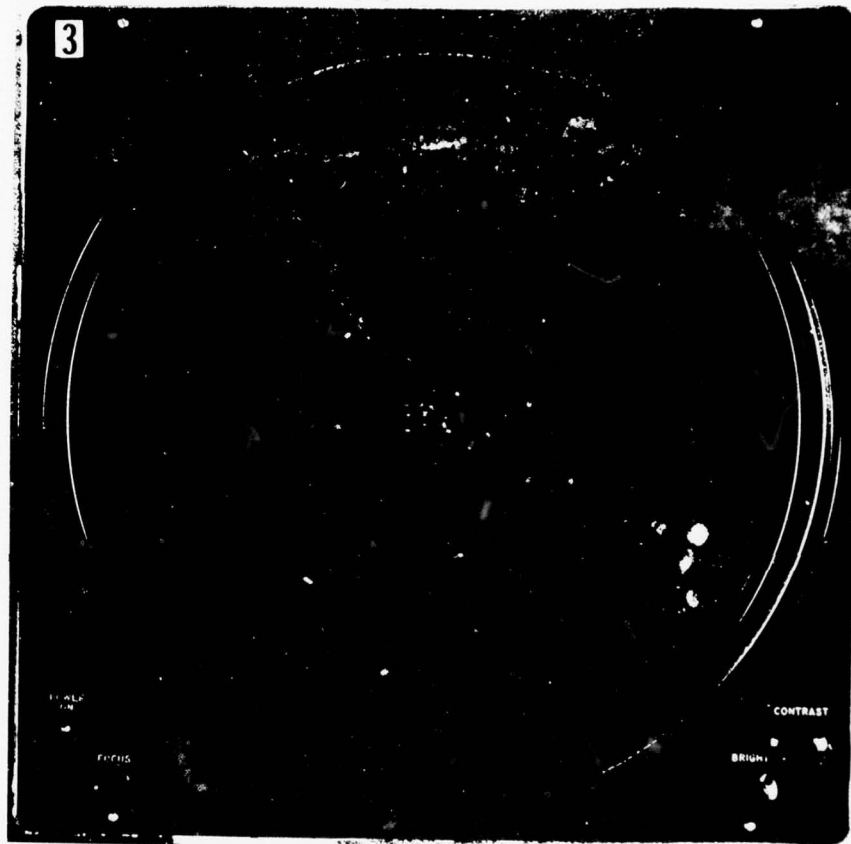

FIGURE 5.1-5. BRITE-4 DISPLAY AT CHICAGO O'HARE WITH BANDS

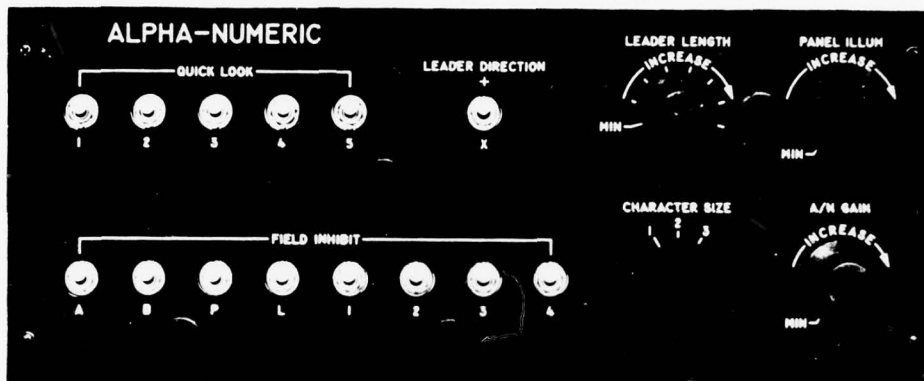
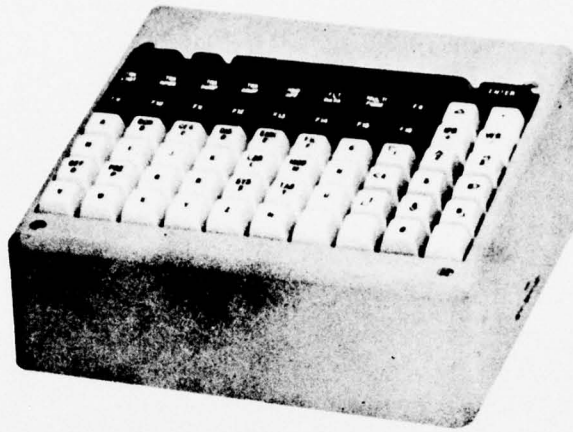
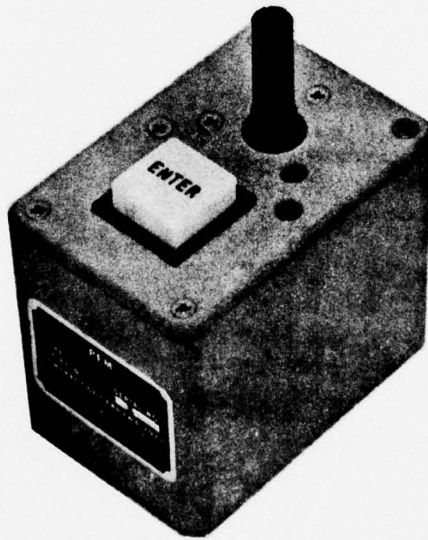

FIGURE 5.1-6. BRITE A/N CONTROL PANEL



A/N Keyboard Assembly



Position Entry Module

FIGURE 5.1-7. A/N KEYBOARD AND PEM

#### 5.1.4 Operational Considerations

The A/N keyboard/PEM configuration was based upon the ARTS III TRACON controller consoles. It provides an effective ARTS interface which could even permit full utilization of ARTS III capability in a TRACAB.

The exact nature of the use of BRITE displays in a particular tower depends on the radar service provided by the TRACON, the runway configurations used, the volume and mix of traffic (jet, air-carrier, general aviation, etc.) and the current weather conditions. At the busiest airports, where most of the Upgraded Third Generation elements may be installed, the TRACON is likely to be a Terminal Control Area with an ARTS III system. For these airports the BRITE A/N equipment will provide the cab's interface with ARTS III, with Local Control being the primary display user and Clearance Delivery being the primary keyboard user. At a TCA, all arrivals will approach under control of the TRACON, virtually eliminating the sequencing role from the cab. In addition, since the aircraft are radar separated and sequenced prior to visual approach, the longitudinal separation function of Local Control for arrivals is also minor. Once on final approach, aircraft which have been sequenced by radar will rarely overtake one another prior to touchdown. Therefore, Local Control is primarily concerned with runway utilization by arrivals and departures.

In the simplest runway configurations, arrivals and departures operate on separate and independent runways. New York-JFK operates in this manner most of the time. In this case the local controller monitors the arrivals to assure that the first aircraft will be clear of the runway before the second touches down. Of course, this is to preclude a collision if the first aircraft misses the proper exit or for some reason cannot clear the runway. If the controller estimates that the second arrival will land before the first will clear, he will direct the second to go around.

In VFR conditions, the controller can see the aircraft and

the pilots can aid in maintaining safe operation during landings. In IFR conditions, the controller cannot see the aircraft and must use the BRITE system without pilot assistance until the pilot can see the runway. The extent of the local controller's task in handling arrivals is depicted in Figure 5.1-8 which consists of plots of the distribution of arrival runway occupancy time (from threshold to committing to turn-off but not including turnoff) and inter-arrival spacing versus time in 10 second bins (e.g., 14 percent of inter-arrival spaces were between 100 and 110 seconds in duration). The data was taken at O'Hare for dry runways with fog. The average inter-arrival time is 130 seconds representing a typical IFR capacity of 28 arrivals/hour. The leading edge of the distribution is just below 65 seconds which represent 3 nautical miles (the minimum separation standard) at a typical approach speed of 160 knots. The inter-arrival distribution represents a combination of (1) the ability of approach control to separate arrivals uniformly, (2) the mix of heavy aircraft requiring 5 nautical miles of separation, (3) the ability of approach control to draw arrivals from their stacks uniformly spaced, and (4) the ability of en route control to accept the scheduled traffic and feed it to approach control with a large degree of regularity.

The shaded overlap in the figure, graphically portrays the controllers' task. If there were no overlap, then the longest roll-out would still be quick enough to clear the runway in the shortest inter-arrival space. The shaded overlap represents those arrivals which were on the runway long enough to have required a close-spaced following arrival to go around. According to the data, this would occur for about 2 percent of the operations or about once per hour. Therefore, the local controller's task is significant and the BRITE display plays an important role. The task becomes even more significant as runways become slippery and runway occupancy times get longer.

The radar separation restrictions do not have as severe an impact on departures as they do on arrivals. Arrivals are sequenced and brought together from various directions to a single

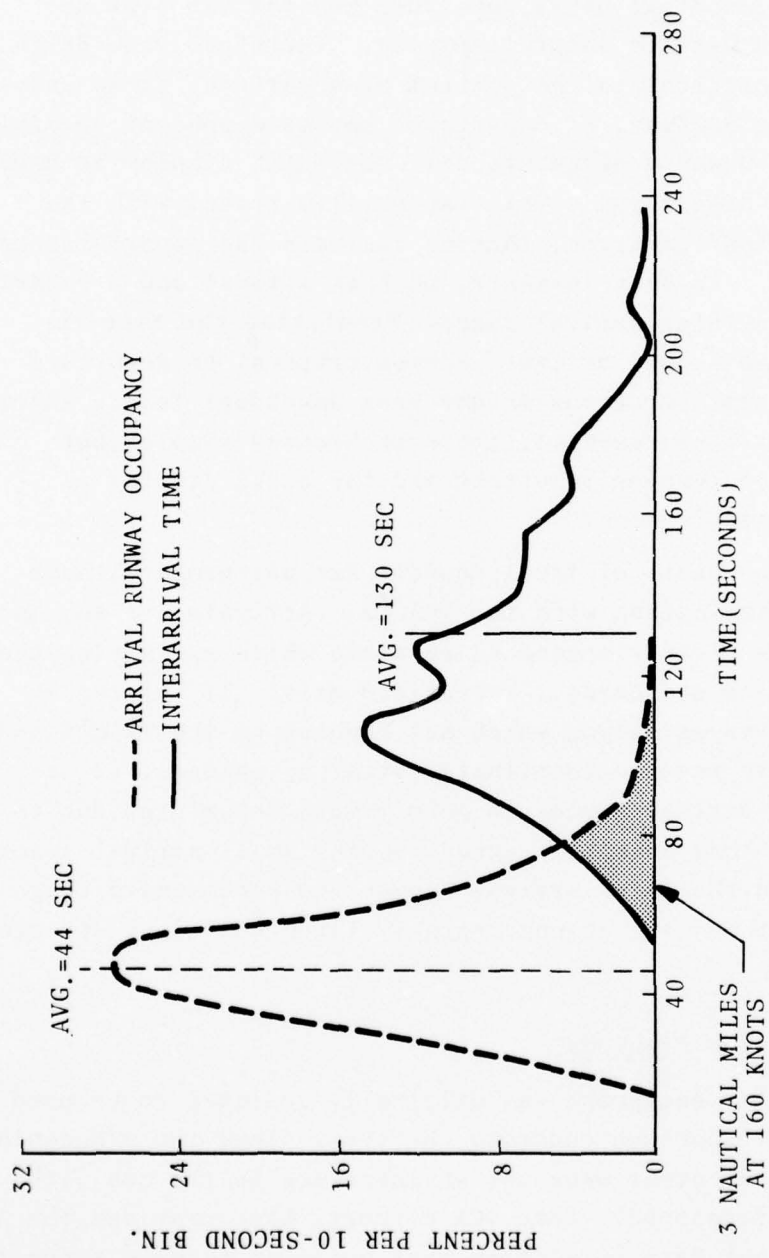

FIGURE 5.1-8. USE OF BRITE DISPLAY FOR RUNWAY CLEARANCE ASSURANCE

runway and longitudinal separation is critical. Departures are generally fanned out in various directions and longitudinal separation is only important until Departure Control can pick up the aircraft and perform lateral spacing. Therefore, the BRITE display is not critical to the control of departures on an independent runway. However, if departures become dependent on arrivals (in other runway configurations), the BRITE display is used in clearing the departures. This can be illustrated with the most dependent configuration, that of arrivals and departures on the same runway. In this instance, both an arrival and a departure must fit into an inter-arrival space. Predicting the time-to-threshold for the second arrival becomes critical to departure clearance. As configurations become less dependent (e.g., intersecting and dual-lane runways), the task becomes simpler, but time-to-threshold remains important and the BRITE display is critical in its estimation.

Normally the tasks of local control are performed without significant communication with the TRACON. Arrivals are sequenced by the TRACON as tightly spaced as possible while satisfying the minimum separation standards. Exceptions exist (1) for runway configuration changes during which all members of the TRACON and cab are likely to require coordinated strategy changes, (2) to widen the inter-arrival spaces to permit more departures due to an unacceptably long departure queue (versus small arrival stacks), and (3) to widen the inter-arrivals spaces to accommodate long rollouts without forcing an unacceptably large number of directed go arounds.

#### 5.1.5 BRITE System Problems

The BRITE A/N equipment was originally designed to be used by Local Control or approach control. However, since the A/N equipment was designed, other uses for an interface in the cab with ARTS have been developed. Some TCA airports have provided the A/N keyboard to Flight Data permitting that position to make requests

to ARTS for beacon code assignments to VFR departures. In addition, Flight Data uses the keyboard to enter the current ATIS letter for display in the cab and the TRACON. The preview area required for these data entry operations is located on the BRITE display which, where currently installed, is difficult or impossible for Flight Data to use. This problem is discussed in some detail in Section 5.3.3.

Tower cabs which are not co-located with a TRACON have another problem. These cabs may be provided with BRITE displays; but present equipment does not permit them to have BRITE remote control heads or A/N equipment keyboards and control panels, which must remain at the parent site. The utility of the BRITE displays at remote locations is thereby limited. Further, these sites have no ARTS interface for Flight Data usage.

There also exists a problem with the quality of the BRITE display, particularly when displaying alphanumerics. The scan conversion process tends to compromise the legibility of alphanumerics because the characters are generated by a set of horizontal lines which cut the alphanumeric randomly. For an alphanumeric to be highly legible it must be cut by fifteen lines. The BRITE display just satisfies this requirement for quarter-inch high alphanumerics. In addition, the TV video bandwidth must be kept high for a high-resolution picture; losses between the PPI and TV display due to cable runs, ageing equipment, etc., can compromise picture quality. The lost resolution can result in fuzzy, difficult to read alphanumerics (see Figure 5.1-5).

## 5.2 SURFACE SURVEILLANCE

### 5.2.1 System Overview

For the most part, airport surface surveillance is conducted visually from the tower cab. Where the cab view of taxiways is obstructed by a building, the FAA can refrain from accepting control responsibility (as at Boston Logan behind the Eastern terminal building prior to occupying their new tower), can install a TV monitor with a view of the obstructed area remoted to the cab (as has been used at LaGuardia and Los Angeles) although past installations have not met with a great deal of success, or can use pilot position reports made by voice radio. Except for such "blind spots", visual surveillance is maintained even through fairly severe IFR weather conditions. Most tower cabs are less than 200 feet in height and so are below the CAT-I ceiling, and viewing range requirements are normally less than 1.5 miles.

When bad visibility does affect the surface surveillance, it generally affects Local Control first. The airport is generally laid out with the terminal "inside" the taxiways (nearest the tower), with the runway furthest from the tower. When bad visibility does affect Local Control, he begins to use pilot position reports in the obscured areas. Such reports are made when an arrival clears the runway, when an arrival passes the threshold (reported by the next departure), or when an aircraft crossing the runway has cleared it. Each of these reports represent critical timing information needed as Local Control clears arrivals to land and departures to take-off.

When visibility is quite poor, Ground Control can be affected as well as Local Control. Under these conditions, Ground Control also uses pilot position reports to keep track of the location of each aircraft. This procedure permits the controller to detect and avoid major routing blunders and adequately control heavily traveled taxiway intersections even though his surveillance is limited. Pilot reports can severely impact on the voice channel loading of both cab control positions but the most pronounced effect is on that of Ground Control.

Ground surveillance radar has been installed at twelve airports to aid both controllers during bad visibility (see Table 5.2-1). The unit, Airport Surface Detection Equipment, ASDE-2, is a high resolution ground mapping radar designed in the late 1950's and installed in the early 1960's. It is the major equipment currently used for tower-cab surface surveillance.

#### 5.2.2 ASDE-2 Description

ASDE-2 is a primary radar whose antenna is often mounted on the roof of the tower cab in order to afford the same view (i.e., coverage and perspective) as that of the controllers. However, installation is possible on a remote tower up to a mile from the cab with transmission of the signal back to the cab via land lines. As originally installed, the radar returns were processed and displayed on a standard radar PPI. As previously discussed, the use of the PPI display in the tower is unsatisfactory because of its low brightness. In the late 1960's, an ASDE BRITE display based on the ASR BRITE was developed and installed (see Section 5.1.1.) All ASDE-2 units now have such a bright display and a typical tower cab roof top installation is shown in Figure 5.2-1.

5.2.2.1 Operational Description - Figure 5.2.2 is a photograph of an ASDE plan view display at New York JFK airport. The runways and taxiways are made visible by the ground clutter return. However, two problems were evident; the background tends to be very muddled and, at locations where ground returns are weak, the display fails to detail the airport surface at all.

Target definition with ASDE-2 can be quite good. In Figure 5.2.2, a departure queue can be seen in the upper right-hand corner of the display. Target extent (wings, tail, nose, etc.) can be plainly seen. Extent is very valuable to the controller in ascertaining runway clearance (e.g., of an aircraft holding near to a runway) and in aiding in target detection. As can be seen in the photo, slowly moving targets can be confused with the background clutter but the shape of the target can aid in resolving such confusion.

AD-A048 306

TRANSPORTATION SYSTEMS CENTER CAMBRIDGE MASS  
CHARACTERIZATION OF CURRENT TOWER CAB ENVIRONMENTS. (U)  
NOV 77 V J HOBBS, D F CLAPP, P REMPFER  
TSC-FAA-77-19

F/G 13/3

UNCLASSIFIED

FAA-EM-77-10

NL

2 OF 3  
AD  
A048306



TABLE 5.2-1 CURRENT ASDE-2 SITES

ACY	Atlantic City NJ (NAFEC)
ADW	Andrews AFB, Washington DC
ATL	Atlanta GA
BOS	Boston MA
CLE	Cleveland OH (in process of commissioning)
EWR	Newark NJ
IAD	Dulles-Washington DC
JFK	New York NY
ORD	Chicago IL
PDX	Portland OR (in process of commissioning)
SEA	Seattle WA
SFO	San Francisco CA

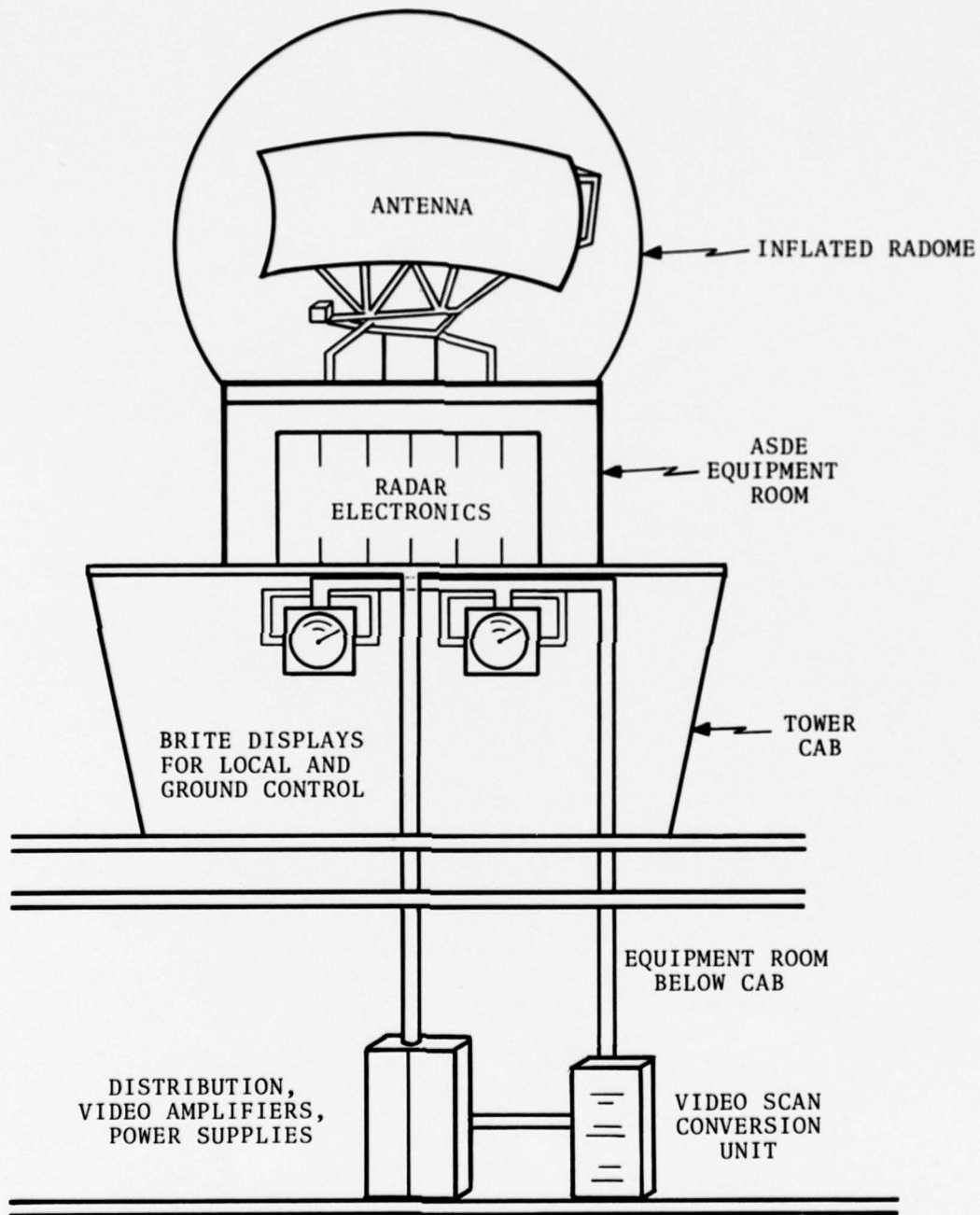

FIGURE 5.2-1. ASDE-2 EQUIPMENT LAYOUT

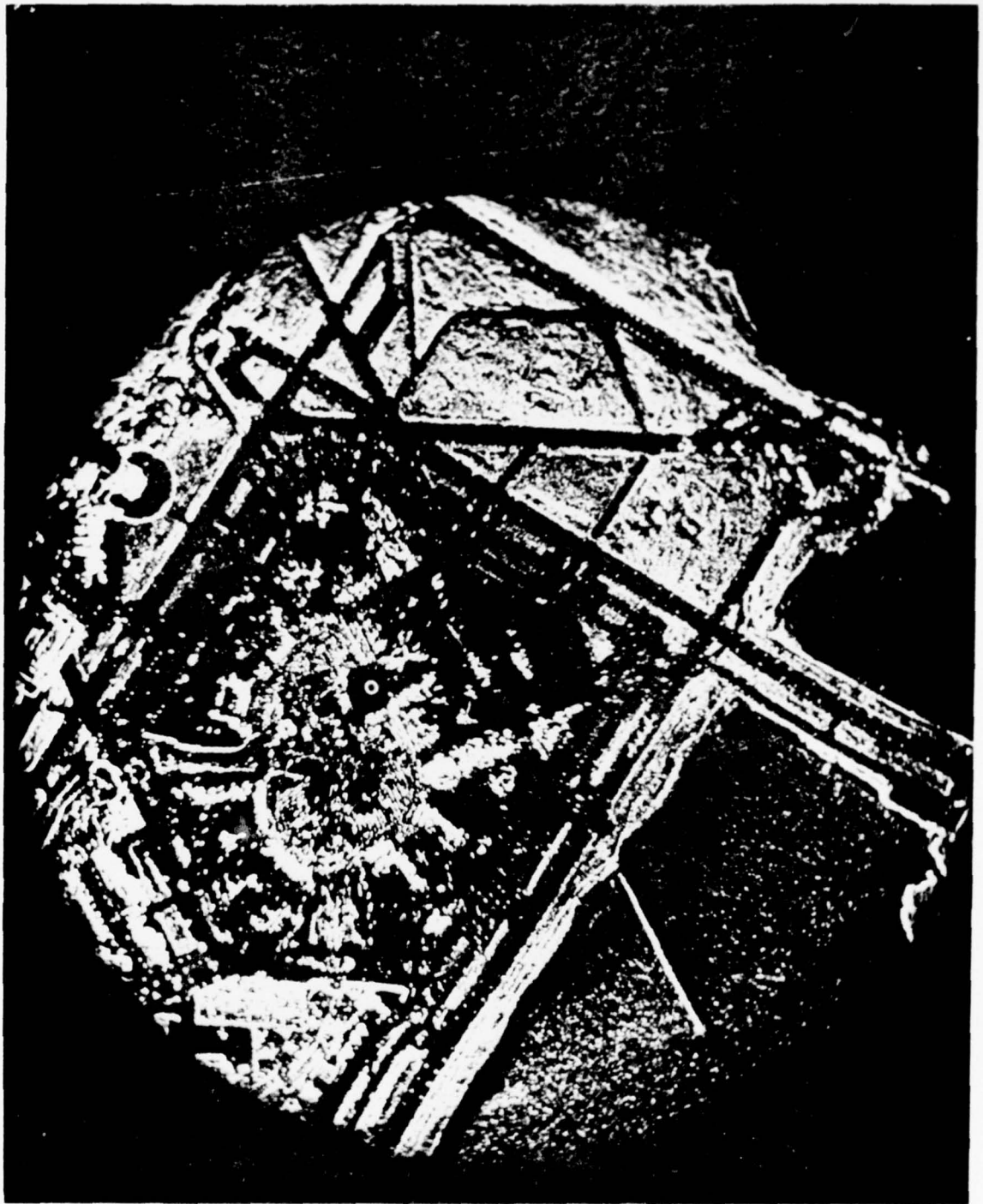

FIGURE 5.2-2. ASDE-2 PPI AT JFK

The target trails which occur on a BRITE display do not occur on a PPI display (see section 5.1.1) and therefore are not shown in Figure 5.2-2 (a PPI photo). The trails give an indication of target speed (long trails for fast moving aircraft) and target course (fading behind the target) both of which are useful to the controller. The course is particularly helpful, permitting the controller to grasp a picture of the traffic flow at a glance without waiting for display updates. In addition, trails provide further assistance in detecting moving targets among ground clutter.

Each independent ASDE channel in the cab has a single control head and can drive two BRITE displays. No airport has more than two independent ASDE channels because of cost and space limitations, which means that frequently controllers must share an ASDE channel. For example, at Chicago-O'Hare two ground controllers and southside local control share one display. Therefore, the display presentation must be adjusted with range and offset settings which tend to compromise its utility to each individual controller.

5.2.2.2 ASDE-2 Characteristics - A block diagram of the ASDE-2 and BRITE display systems is shown in Figure 5.2.3\* The ASDE-2 is a high-resolution, conventional fixed-frequency radar using vacuum tube technology (1950's) which operates at 24 GHz and rotates at 60 rpm. Refer to Table 5.2.2 for a listing of ASDE-2 component characteristics. The major subsystems are: a dual-channel transmitter/receiver, a horn-fed parabolic reflector antenna with radome, and a BRITE display system.

In the original design, the antenna/pedestal assembly was protected from the weather by a spherical air inflatable radome made of rubberized fabric. Geodesic space frame radomes were installed subsequently at O'Hare, Logan, and Andrews to provide improved rain shedding characteristics and prolonged exterior coating life.

The specified radar resolution capability of the ASDE-2 based on the transmitted pulse width and the azimuth beam width is 20

\* See Appendix A for a detailed description of ASDE-2 .

TABLE 5.2-2. ASDE-2 CHARACTERISTICS

<u>Component</u>	<u>General Characteristic</u>
<u>Transmitter</u>	
Frequency	23,800 to 24,270 MHz (1.25 cm band)
Pulse width	20 nanoseconds
PRF	14.4 kHz
Peak Power	36 to 50 kW
<u>Receiver</u>	
Noise Figure	19 dB (maximum)
Bandwidth	IF 100 MHz; Video 50 MHz
Features	AFC local oscillator, STC, FTC
<u>Antenna/Pedestal</u>	
Reflector Size	12 by 4 feet
Gain	45 dB
Horizontal Beamwidth	0.25 degree at 3 dB points
Vertical Beamwidth	1° to 3 dB points, cosecant squared -1° to -5°, linear
Tilt	From -5° to -20°
Polarization	Linear or circular
Scan	60 rpm
<u>Raddome</u>	Spherical 1) Inflatable, 2) Geodesic Space Frame (Logan, O'Hare), 3) Foam (Andrews)
<u>Rooftop Equipment Weight</u>	Approx. 2500 pounds

TABLE 5.2-2. ASDE-2 CHARACTERISTICS (CONT'D)

<u>Display System</u>	Analog Scan Converter (ASDE BRITE)
TV	945 line, 16 in. dia., 14.5 in. usable viewing surface diameter
PPI	5 in. mechanical yoke
Vidicon	Optically coupled to PPI, 945 line
System Bandwidth	20 MHz

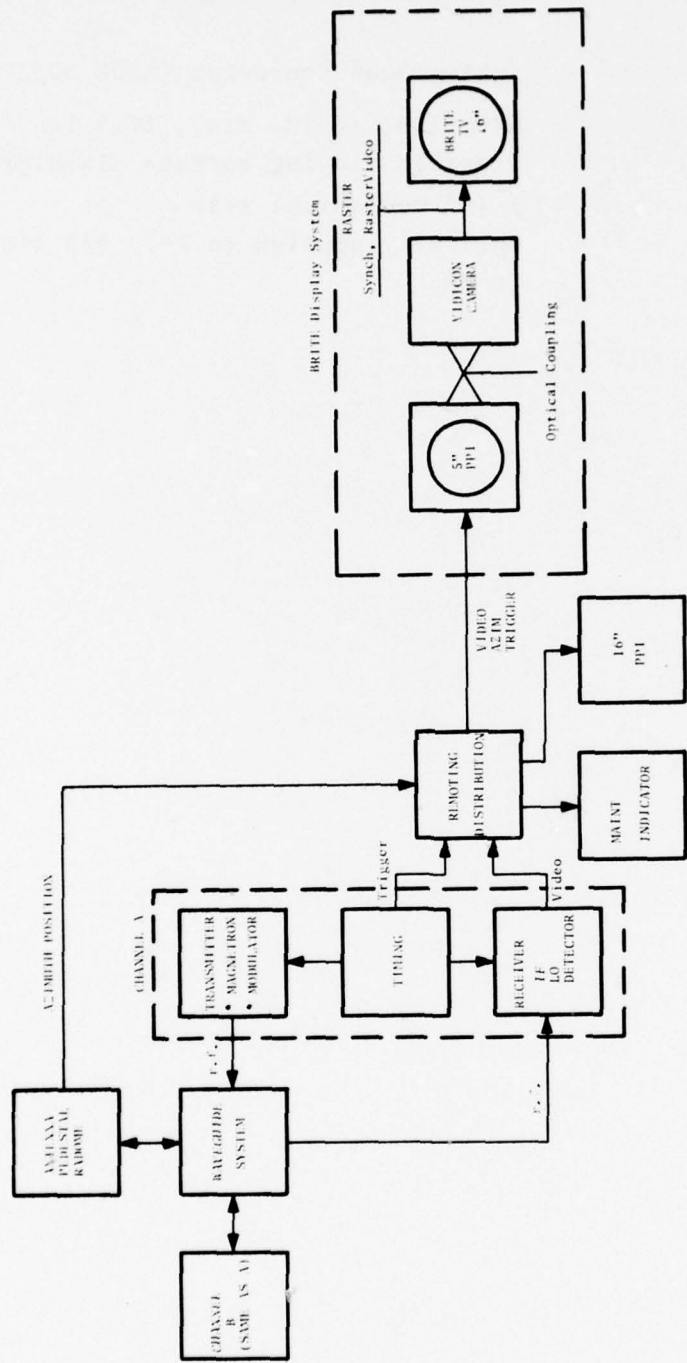

FIGURE 5.2-3. ASDE-2 RADAR AND BRITE DISPLAY BLOCK DIAGRAM

feet in range and 27 feet in azimuth at 4,000 foot range (Table 5.2-3). Field measurements made of eight installed systems indicate that resolution through the PPI, which includes the operator's determination of target separation, is less precise by a factor of nearly two. Scan conversion results in a further degradation of resolution; by 2 to 1 midrange, and by 3 to 1 at maximum range.

Table 5.2-4 lists the major classes of airport surface targets and the degree to which the ASDE defines their characteristics. The ASDE is capable of displaying the shape of heavy and very heavy aircraft, essential for aircraft identity-to-target correlation done mentally by the controllers.

The ASDE-2 is capable of displaying small targets out to a 3-nautical-mile range in clear weather. However, in precipitation, coverage is severely restricted due to several effects:

- a. RF path attenuation by precipitation is high at 24 GHz producing "blackout", i.e., loss of valid targets.
- b. RF backscatter radiation from precipitation particles is high at 24 GHz, causing displayed clutter, or "whiteout."
- c. Radome rain sheeting and water absorption increases attenuation loss and echo box effects.

The lack of small-target detection performance margin combined with the high RF attenuation of the 24 GHz waveguide restricts the variety of installation configurations available to the ASDE-2. Tower cab installations where the radar equipment room is not located immediately below the antenna pedestal cannot be accommodated without serious loss in performance.

The considerable weight and wind-induced overturning moment of the rooftop equipment also limits its installation to substantial tower cab roofs.

TABLE 5.2-3. SYSTEM RESOLUTION CHARACTERISTICS

	<u>Range</u>	<u>Azimuth</u>
Radar (Theoretical)	20 ft	27 ft at 4000 ft range (0.39°)
Through PPI (Measured)	44 ft (avg. of 8)	37 ft at 4000 (0.53°)
Through BRITE (Measured)	60 ft to 80 ft	60 ft at 4000 ft range (0.85° average of two)

TABLE 5.2-4. TARGET DEFINITION CHARACTERISTICS

<u>Class/Type</u>	<u>Length</u>	<u>Definition of Image</u>
Light Aircraft (Cessna 150, Service vehicle)	up to 50 ft	Operator able to classify as "light"
Heavy Aircraft (DC-8)	90 to 160 ft	Operator able to classify as "heavy" discern shape*
Very Heavy Aircraft (B-747)	180 ft and above	Operator able to classify as "very heavy", discern shape*

\*See component of wings where area exceeds 900 sq. ft.

TABLE 5.2-5. BRITE DISPLAY CHARACTERISTICS

<u>COMPONENT</u>	<u>NU-BRITE</u>	<u>ASDE BRITE</u>
PPI		
o Diameter of CRT	5 in	5 in
o $\rho$ - $\theta$ Sweep	Solid State	mechanically driven yoke
o Video Bandwidth	35 MHz	20 MHz
Vidicon		
o Lines	1225	945
o Video Bandwidth	35 MHz	20 MHz
BRITE TV		
o Lines	1225	945
o Video Bandwidth	35 MHz	20 MHz
o Diameter of CRT	16 in	16 in

### 5.2.3. ASDE-2 System Problems

5.2.3.1 Airports Without ASDE-2 - Poor visibility conditions at airports without ground surveillance radar leads to use of pilot position reports for surveillance. Local Control uses these reports for the timing of runway operations. However, pilot reports can be somewhat inaccurate (i.e., late or early) requiring that a safety buffer be introduced by the controller which reduces the runway capacity. The extent of capacity loss depends on the runway configuration (i.e., the combination of arrival and departure runways in operation).

The impact of the use of position reports by Ground Control is to dramatically increase his use of the voice radio. Therefore, voice channel saturation will occur much sooner under bad visibility conditions, limiting the capacity of the controller to handle traffic.

5.2.3.2 Airports with ASDE-2 - ASDE-2 has provided significant capacity improvements under bad visibility conditions by restoring to Local Control the capability to determine and estimate timing of critical runway-related events. The runways are readily discernable on the display (see Figure 5.2-2) and the targets are easily identified since their sequence is generally known and their location can be anticipated.

However, ASDE-2 does not improve Ground Control's operation to the same extent. Identification of targets by Ground Control is difficult because surface traffic is located over a wide area of taxiways; aircraft can be in close proximity to one another, either moving or stopped. In addition, the airport map is not always presented clearly enough on the display to aid in target detection and to maintain knowledge of target identity. Therefore, even with ASDE-2 in operation, Ground Control uses pilot position reports.

While ASDE-2 has proved to be a useful operational tool, it has been the subject of a steady stream of complaints from the field due to a variety of equipment deficiencies, such as:

a. The original ASDE BRITE was a modification of the ASR BRITE-2. However, the bandwidth and resolution requirements for presenting an ASDE picture adequately are far more severe than those for an ASR. As a result, target definition and overall picture quality were quite poor on the ASDE display .

b. The map produced by the ground clutter was frequently inadequate, especially in the taxiways, making it difficult to pick out a target in clutter and to determine on which taxiway a detected target was located.

c. ASDE-2 is currently 15 years old. Over the last several years, the units have developed a variety of maintenance problems due to age, out-dated vacuum tube technology, and parts unavailability.

d. The problem most quoted by controllers is that ASDE-2 fails to perform well in heavy rain. The picture tends to show white clutter in the radar return from the rain cell, thus obliterating the targets and black areas behind the rain cell from lack of signal strength getting through the rain. These effects are due to a combination of a high, weather sensitive operating frequency (24 GHz) and radome characteristics.

#### 5.2.4 ASDE Related Equipment

5.2.4.1 A New ASDE Bright Display (NU-BRITE) - In view of the problems being experienced with the ASDE BRITE display, a new high bandwidth and resolution bright display was developed in 1973 for special application to ASDE. An engineering model was constructed and installed at New York JFK for operational evaluation and comparison with the ASDE BRITE. A comparison of the parameters of the two systems is given in Table 5.2-5. The primary objectives of the system were to provide picture quality, target definition, and above all, target detection. Field experiments conducted with controllers indicated up to a 40 percent improvement in target detection with the NU-BRITE display. Another objective was to provide an improved control head (described below). Following a successful evaluation, a production procurement of 3 systems was initiated for New York JFK, Chicago O'Hare and San Francisco;

installation of these units was completed in mid CY 76. No decision has been made by AAF to extend deployment to other sites, however, the Western Region (AWE) is considering procurement of two NU-BRITE systems for the Los Angeles ground surveillance radar (see Section 5.2.4.2).

The NU-BRITE control head is shown in Figure 5.2-4. It has the same size and weight characteristics as the ASDE BRITE control head. It too provides brightness, contrast, and an erase function. It differs in its range and offset controls. Range selection is continuous rather than discrete and minimum range is 3000 feet. This permits optimum range selection including only areas of interest on the display to get the best target size and resolution. Use of minimum range permits Ground Control to improve his ability to detect targets if he has his own display and centers it on the taxiway hub. Offset also is continuous (as with the ASDE BRITE) but is independent of the range selected. Maximum offset is 9000 feet on any range selected. The independence of range and offset is important to make use of the minimum range selection, especially at remotely located ASDE antenna installations.

Examples of how the display presentation can be set up for ground and northside local control at Chicago O'Hare are shown in Figures 5.2-5/6. Figure 5.2-5 shows how the minimum range scale enlarges the view of the critical taxiway system at O'Hare for Ground Control. However, use of such a limited viewing area excludes information on the rest of the airport which might occasionally be required. To solve this problem, two presentations can be set up on the control head (see Figure 5.2-4). Presentation 1 could be set up with minimum range and presentation 2 could be set up with a large range as shown on Figure 5.2-5, selectable by means of a simple switch. Figure 5.2-6 shows how the two presentation feature could be used by northside Local Control.



FIGURE 5.2-4 NU-BRITE CONTROL HEAD



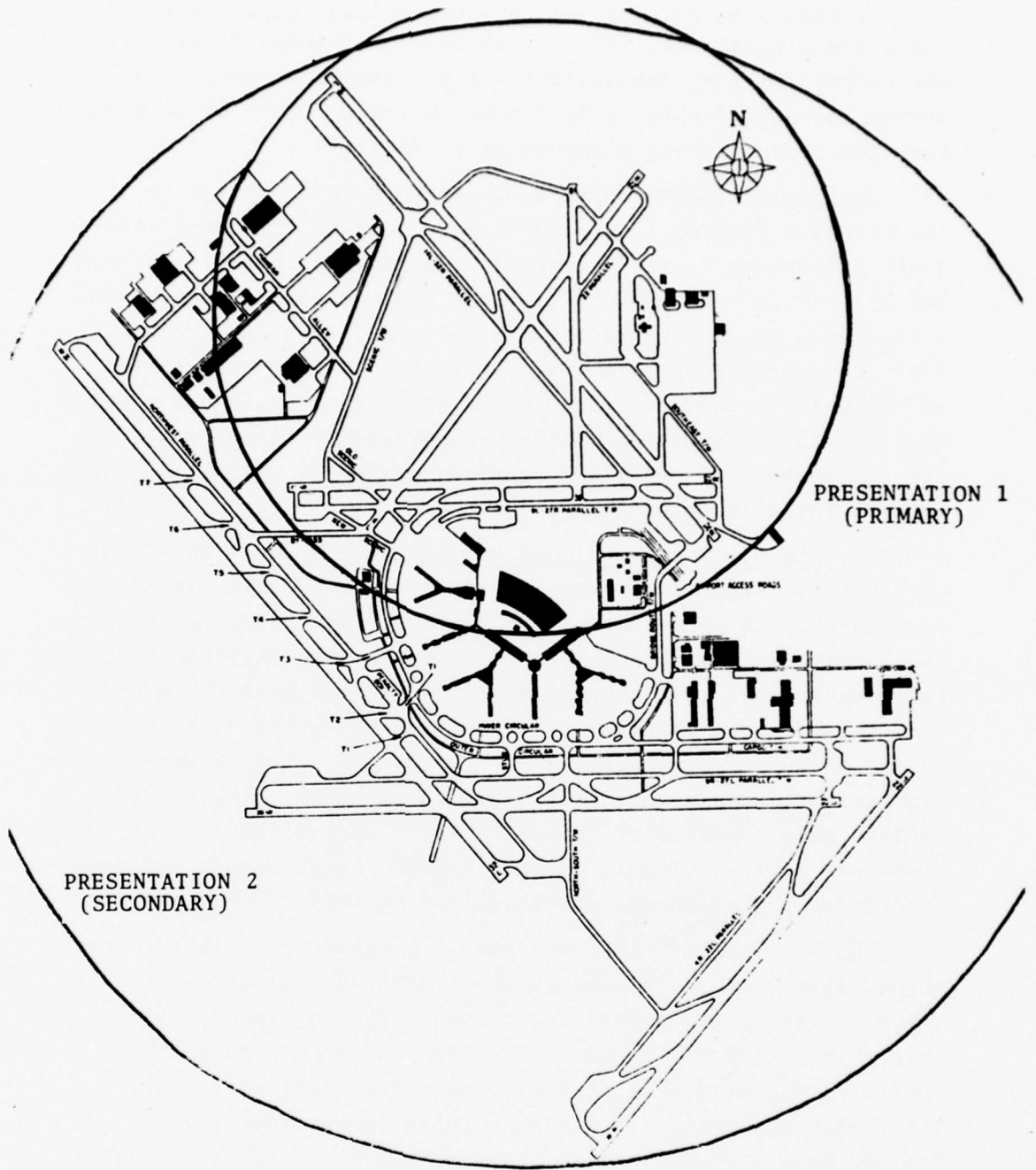

FIGURE 5.2-6. TYPICAL PRESENTATIONS FOR NORTH LOCAL CONTROL AT O'HARE

It should be pointed out that the Ground Control option cited above could not, in fact, be used at Chicago O'Hare with the current display configuration since southside Local Control shares the ASDE display with Ground Control. There is no room in the console to install separate BRITE displays.

Physically the NU-BRITE is similar in basic design to the original ASDE BRITE system (Figure 5.2-7). The most significant difference is the increased bandwidth in the PPI, vidicon and TV from 20 MHz to 35 MHz. Field measurements indicate that system resolution through the display, including operator activity, is improved by 2 to 1 over the ASDE BRITE. Reliability and adjustment ease are improved by the use of solid state electronics, the elimination of the mechanically rotating yoke, and the replacement of the alternator/cam system by a 12-bit optical encoder for azimuth data generation.

5.2.4.2 The Los Angeles Ground Surveillance Radar - When ASDE-2 was installed at Los Angeles, it was determined that the antenna structure would be too heavy for the cab; therefore, the antenna was installed at a remote site. Since that installation the airlines have found it necessary to build hangars near the ASDE-2 site resulting in blind spots. To solve the problem the airlines acting through the airport authority, funded a new radar with a lightweight antenna for installation on the cab. The specifications were supplied by the FAA Western Region (AWE). The radar was built by Texas Instruments, Inc. based upon a helicopter ground mapping radar and was installed in 1973.

The Los Angeles radar antenna is covered by a plastic shell shaped like a short helicopter blade with an oval cross section which serves as its protective radome. The entire assembly weighs less than 500 pounds. The combination of the antenna aperture, dictated by the requirements for light weight and the chosen operating frequency, results in good performance in fog and haze although not in heavy rainfall. Since bad visibility at Los Angeles is primarily due to fog and haze, this compromise works out quite well there.

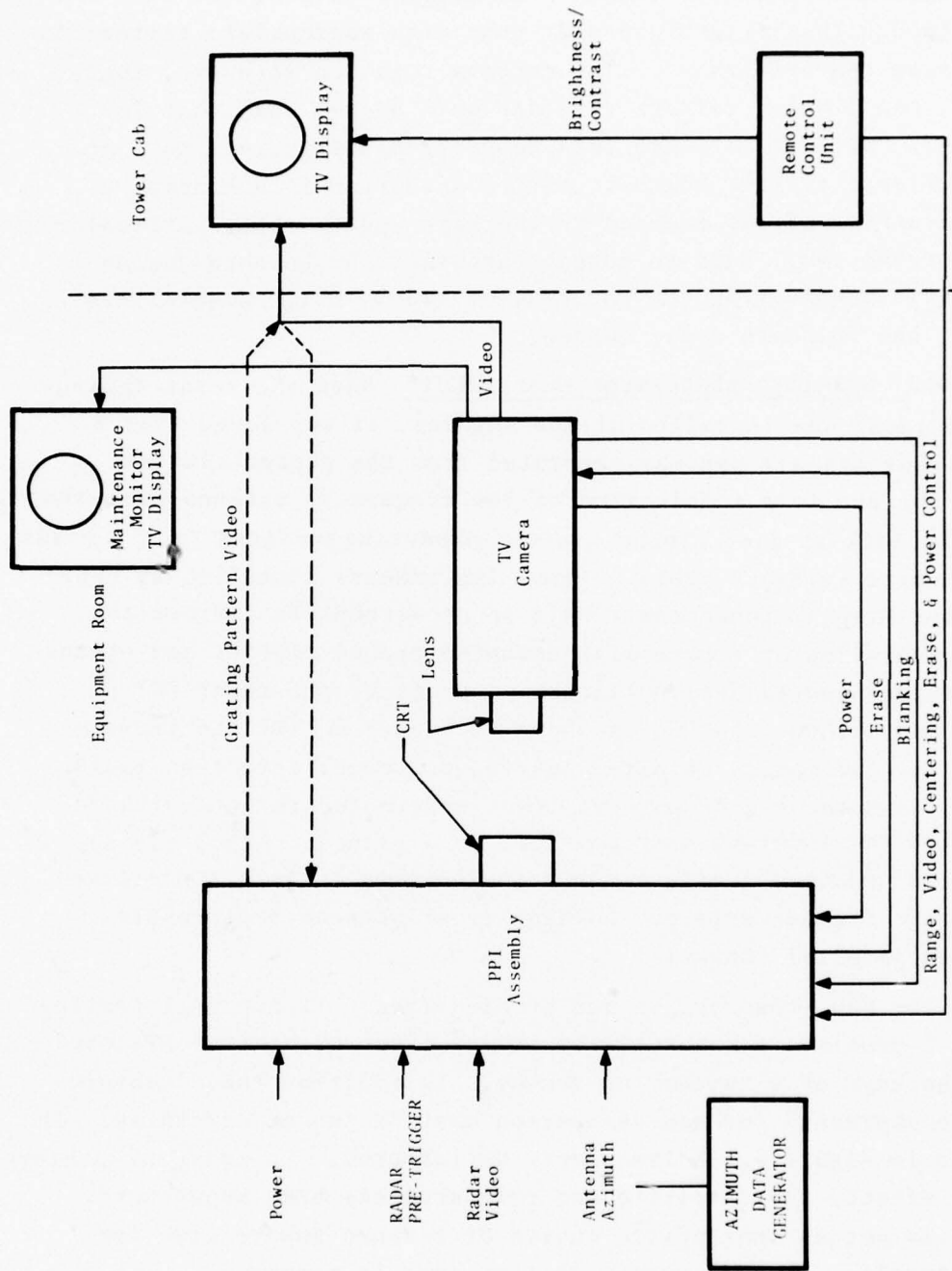

FIGURE 5.2-7.. ASDE-BRITE SYSTEM BLOCK DISPLAY

The radar is furnished with two independent PPI displays and associated control heads. The display is a direct view PPI equipped with a bright-phosphor tube with appropriate filters to maximize the brightness. The antenna rotation rate and, therefore, the display refresh rate are much higher than that for ASDE-2. Without TV video scan conversion, the targets have no appreciable trails; however, target detection is enhanced by the flashing effect imposed by the high update rate, particularly for the small hard-to-detect targets. The Western Region (AWE) is considering the purchase of two NU-BRITE display systems, one for each radar channel.

5.2.4.3 Display Enhancement Unit (DEU)\* When the Texas Instruments radar was installed at Los Angeles, it was found that a very poor airport map was generated from the ground clutter. This was due to a combination of low frequency, antenna beam shape, and the lack of good ground clutter producing surfaces (e.g., grass) in several critical areas. Texas Instruments installed an experimental Display Enhancement Unit in an attempt to improve the map generation by suppressing unwanted ground clutter and enhancing runway and taxiway outlines. A photo of the radar PPI with and without the DEU is shown in Figure 5.2-8; the improvements are dramatic. Limited testing on target detection indicates as much as a 45 percent fewer undetected targets with detection and location made possible at a glance. Also, the map outline and target extent could now be used to detect positive aircraft clearance (e.g., holding clear between two closely spaced parallel runways).

The DEU, however, is not problem-free. If map registration is not precise it can actually hide a light aircraft positioned at the edge of a taxiway or runway. In addition those features to be suppressed for map definition must be chosen carefully. The photo in Figure 5.2-8 looks very uncluttered. In order to achieve this effect, the satellite and ramp area has been suppressed. This is not an appropriate choice of feature suppression for Los Angeles, since coverage in that area is required.

\*See Appendix A for further discussion.

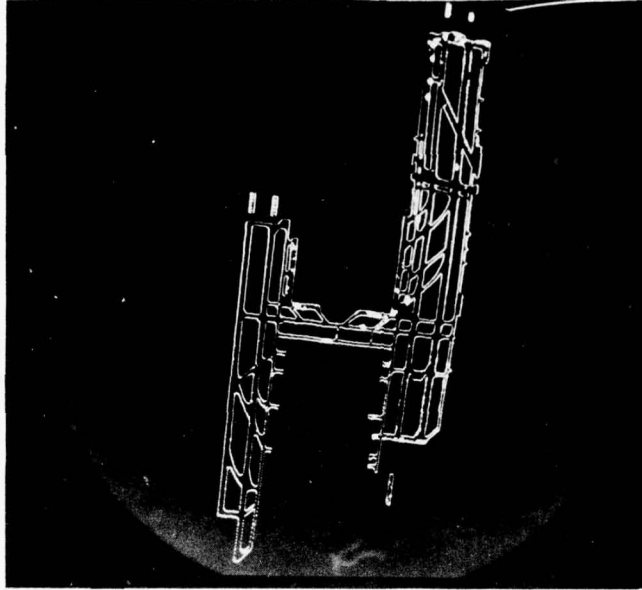

WITH DEU

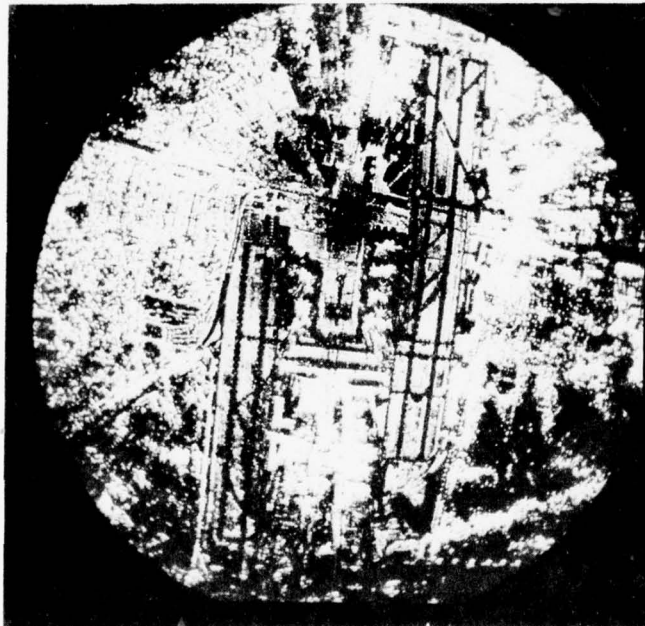

WITHOUT DEU

FIGURE 5.2-8. TEXAS INSTRUMENTS GROUND SURVEILLANCE RADAR AT LOS ANGELES

The controls on the DEU permit separate brightness control for the video within the map, the map itself, and the video outside the map. This latter feature allows for partial suppression of background clutter and can be useful in exposing areas of occasional concern.

Since the experimental DEU was quite successful at Los Angeles, it was decided to examine the unit on ASDE-2. In 1973 the unit was removed from Los Angeles for about a month and installed on the ASDE-2 at New York JFK. The unit was examined in operation with the NU-BRITE display engineering model. Tests results were deemed acceptable by Air Traffic (AAT). Airway Facilities (AAF) is in the process of procuring 13 production DEU's for ASDE-2 and replacement of the experimental model at Los Angeles.

### 5.3 TOWER CAB FLIGHT DATA SYSTEM

#### 5.3.1 Overview

This system description is divided into three parts; the nationwide NAS Stage A flight data system and the role of the cab in that system, the flight data and flight data management system used by Ground Control and Local Control to handle their traffic, and the cab flight data retention system.

5.3.1.1 Nationwide NAS Stage A Flight Data System - Role of Tower Cab - The flight plan provides the information which is basic to air traffic management; it identifies the aircraft, its pilot, and his flight intentions. Figure 5.3-1 shows the standard format for domestic flight plan filing as well as a sample coded flight plan message. The repository of all IFR flight plans is the enroute NAS Stage A computer complex (ARTCC computers). Scheduled airlines and military flights that periodically use the same flight plan have their flight plans stored semi-permanently in the ARTCC computer. All other IFR flights submit their flight plans via phone or air-ground radio either to the local ARTCC, Flight Service Station, or Air Traffic Control tower. On entry of a flight plan, the NAS Stage A computer checks it for

FEDERAL AVIATION AGENCY <b>FLIGHT PLAN</b>				Form Approved. Budget Bureau No. 04-R072.3			
				1. TYPE OF FLIGHT PLAN		2. AIRCRAFT IDENTIFICATION	
				VFR		VFR	
				IFR		DVR	
3. AIRCRAFT TYPE/SPECIAL EQUIPMENT <input checked="" type="checkbox"/>		4. TRUE AIRSPEED	5. POINT OF DEPARTURE	6. DEPARTURE TIME		7. INITIAL CRUISING ALTITUDE	
		KNOTS		PROPOSED (Z)	ACTUAL (Z)		
8. ROUTE OF FLIGHT							
9. DESTINATION (Name of airport and city)				10. REMARKS			
11. ESTIMATED TIME EN ROUTE		12. FUEL ON BOARD		13. ALTERNATE AIRPORT(S)		14. PILOT'S NAME	
HOURS	MINUTES	HOURS	MINUTES				
15. PILOT'S ADDRESS AND TELEPHONE NO. OR AIRCRAFT HOME BASE				16. NO. OF PERSONS ABOARD	17. COLOR OF AIRCRAFT	18. FLIGHT WATCH STATIONS	
CLOSE FLIGHT PLAN UPON ARRIVAL				<input checked="" type="checkbox"/> SPECIAL EQUIPMENT SUFFIX A -- DME & 4096 Code transponder B -- DME & 64 Code transponder D -- DME		L -- DME & transponder--no code T -- 64 Code transponder U -- 4096 Code transponder X -- Transponder--no code	

FAA Form 7233-1 (4-64) FORMERLY FAA 398

1032-027-8000

ZAU

RFD 1604016 FP N4152 C182/A 130 RFD P1700 160

RFD.V255. MLI. V434. . V216. HLC. V4. DEN/0309

DECODED:

To: Chicago Center

Fm: Rockford FSS, ORIGINATED 1604 GMT, 16th message of day

Flight Plan Aircraft #N4152 Cessna 182 equipped with 4096 code transponder and DME, airspeed 130 knots, depart Rockford 1700 GMT; 16,000 feet; route of flight: V255, MLI, V434, V216, HLC, V4. Destination Denver. 3 hours 9 minutes ETE.

FIGURE 5.3-1. FLIGHT PLAN FORMAT AND TYPICAL SUBMISSION

reasonableness, such as proposed airspeed versus indicated aircraft type, and then stores the plan. Then fifteen to thirty minutes prior to the indicated departure time, the NAS Stage A computer assigns the flight a beacon code and distributes flight strips, containing data pertinent to the flight, to the TRACON, tower cab, and center sector of departure. On receipt of the strip in the tower cab, a controller will typically call the center by means of the ATC interphone to obtain departure clearance for the flight before contact is made with the pilot. This call is not necessary at those busy airports where a letter of agreement exists stating that the cab receipt of the strip in itself signals clearance for the flight to proceed. The reading of the flight clearance to the pilot (i.e., clearance delivery) by the tower via the air-ground radio is authorization for the IFR flight.

Upon takeoff, the flight's departure time is entered into the NAS Stage A computer which then commences flight data processing for the flight. This consists of time-over-fix up-dates, and of the correlation of the flight plan to the flight track. As the flight proceeds through controlled airspace, the computer causes a flight progress strip based on the processed flight data to be printed out at the next enroute center or terminal area to handle the flight 15 to 30 minutes prior to the entry of the flight into the ATC facilities airspace. The printed strip is removed from the printout device, inserted into a holder and placed in a rack in view of the controller who is to handle the flight.

In addition to providing flight progress strips to controllers, this complex of computers, with its store of submitted flight plans and processed flight data provides the Air Traffic Service with the means to manage traffic on a nationwide scale. With this tool, the Air Traffic Service can predict peak demand levels, can monitor the system for traffic bottlenecks, and can adjust traffic flows so as to reduce the impact of demand surges, recurring bottlenecks, weather, and ATC equipment failures.

From this simplified description of the national NAS Stage A flight data system, two points are evident concerning the control tower cab. 1) The tower cab services the system by providing clearance delivery, by providing the IFR departure times which initiate the computer's flight data processing and occasionally accepting and relaying flight plan submissions when requested; but the cab is only partially serviced by the system as evidenced by the fact that flight progress strips are not normally provided to the cab for IFR arrivals. 2) The cab receives IFR departure flight strips primarily for clearance delivery, and then only at airports with sufficient traffic. This traffic level varies from region to region, but in the New England Region the required traffic level is 100,000 annual itinerent operations while it is 20,000 instrument operations per year in the Western Region.

At airports with less traffic, the controller uses the inter-phone voice link to the parent TRACON/ARTCC to transmit IFR departure times and to receive flight plan clearances, and occasionally at some airports to relay flight plan submissions. As a memory aid, the controller will use a scratch pad to record the information that is to be relayed. With sufficient traffic, the cab will qualify for Flight Data Entry and Printout (FDEP) equipment. The FDEP permits the cab direct access to the NAS Stage A computer. Flight Plans and Clearances are received by means of the printer and flight plan submissions and IFR departure times are entered by means of the keyboard.

5.3.1.2 Ground and Local Control Flight Data System - The cab flight data system provides controllers with the nonsurveillance information on each aircraft that they require to manage the traffic under their control. The more important data and data management requirements of cab controllers in carrying out their various traffic management functions are:

COMMUNICATIONS (controller to pilot) - In order to communicate with a pilot, the controller must know the aircraft flight number and have a method by which he can readily correlate the flight number with the actual aircraft.

DEPARTURE RUNWAY ASSIGNMENT - When multiple departure runways are in use, the controller uses the departure's first fix and weight class in selecting the departure runway.

TAXIWAY ROUTE ASSIGNMENT - To make a route assignment for any aircraft or other vehicle, the controller needs to know its identity and destination on the airport. For departing aircraft this consists of knowing the runway assignment and also of knowing if the aircraft requires special handling, such as a flow control restriction being in effect which requires the departure to be delayed before take-off. For arriving aircraft, this consists of knowing the aircraft's gate assignment and whether the aircraft requires special handling, such as a hold due to its gate not having yet been cleared by its previous occupant. These are general data requirements which can vary from airport to airport or even at the same airport. For instance, if an airline's gates are grouped together in the terminal area, then it may only be necessary for the controller to know the name of the airline, which he can obtain from the flight number, instead of the flight's gate assignment in order to direct arrival to the appropriate entry point in the terminal ramp area.

TRAFFIC SEQUENCING - Controllers sequence traffic at normal merge points in the airport traffic flow pattern in order to reduce slow-downs and to increase the utilization of the departure runways. To do this the controller needs to know each aircraft's assigned route, hold requirements, and for departures their first fix and weight class.

RUNWAY CONTROL - Local Control needs to know aircraft weight class to establish separation requirements and aircraft type to be able to estimate an aircraft's performance. Knowledge of probable aircraft performance allows Local Control to predict the amount of time the aircraft will

spend on the runway and closing rates between tandem operations on the runway.

MONITOR TRAFFIC - To effectively monitor traffic, the controller needs to know what instructions have been issued to each aircraft under his control.

In summary, whereas the specific Local Control and Ground Control requirements for data and data management functions may vary from site to site, they generally include the following:

Non-Surveillance

Data Requirements

Flight Number	}	for arrivals and departures
Weight Class		
Aircraft Type		
Gate	}	for arrivals only
Gate Delay		
First Fix	}	for departures only
Flow Control		
Restrictions		
Identity	}	for non arrivals/departures such as tow and FAA maintenance vehicle
Airport Destination		

Data Management Functions

Maintain flight data

Correlate flight number with actual aircraft

Maintain a log of instructions issued to each aircraft

At the smallest cab facilities, the flight data required for Local and Ground Control traffic management purposes is obtained by means of the controller-to-pilot voice channel, the interphone link to the parent ARTCC or TRACON, and the cab window. Table 5.3-1 shows the typical equipment used to obtain the flight data. The interphone provides the flight numbers of the arrivals that are about to be handed off to Local Control and any flow control

TABLE 5.3-1. FLIGHT DATA VERSUS CAB EQUIPMENT CURRENTLY USED

<u>CAB FLIGHT DATA</u>	<u>MINIMUM CAB EQUIPMENT [ NO FDEP NO A/N BRITE ]</u>	<u>CHANGE DUE TO FDEP</u>	<u>CHANGE DUE TO A/N BRITE</u>
<b>IFR ARRIVALS</b>			
Flight Number	Interphone		A/N BRITE
Weight Class	Voice Channel		A/N BRITE
Aircraft Type	Cab Window		A/N BRITE
Gate	Voice Channel		
Gate Delay	Voice Channel		
<b>IFR DEPARTURES</b>			
Flight Number	Voice Channel	FDEP	
Weight Class	"	FDEP	
Aircraft Type	"	FDEP	
First Fix	"	FDEP	
Flow Control Restrictions	Interphone		
<b>VFR ARRIVALS</b>			
Flight Number	Interphone		A/N BRITE
Aircraft Type	Cab Window		A/N BRITE
Airport Destination	Voice Channel		
<b>VFR DEPARTURES</b>			
Flight Number	Voice Channel		
Aircraft Type	Cab Window		
Direction of Flight	Voice Channel		
<b>NON ARR/DEP TRAFFIC</b>			
Identity	Voice Channel		
Airport Destination	Voice Channel		

restrictions that are to be imposed on departures. The cab also receives the arrival flight numbers a little later, when the pilots check in to Local Control at the outer markers. The controllers determine aircraft type by observation through the cab window as needed, although under poor visibility conditions they use the voice channel to obtain the information. All remaining flight data is acquired by means of the voice channel. To the extent that the needed information is not on hand when required, the controller will request the information from the pilot; however, pilots tend to provide all the information needed upon initial contact with that controller (e.g., "AA 111 Heavy with you off runway 14L going to gate 10 and expect a 10 minute gate delay").

At airports with higher traffic levels, two other flight data sources are available to the cab, FDEP and ARTS BRITE. FDEP provides all pertinent flight data for IFR departures with the exception of flow control restrictions, which are obtained by means of the interphone. On the ARTS BRITE display used by Local Control, each target is shown with a data block that contains the target's flight number and, as a *site option*, the target's aircraft type. A tower cab qualifies for this display system if its parent TRACON is ARTS III equipped, the airport handles 35,000 annual itinerent operations or more and the airport is within 20 miles of the parent TRACON.

Once the flight data is obtained by the cab, it must be maintained and distributed to the controllers as needed. In order to manage the traffic in contact with the cab, the controllers must be able to keep track of the instructions that have been issued to each aircraft (such as, assigned runway, assigned taxiway route, assigned holding area, etc.) and be able to correlate aircraft flight numbers with the actual aircraft for communication purposes.

The demand on the internal cab flight data system varies with airport traffic volume. At airports with low traffic levels, the cab conducts single runway operations, the taxiway traffic flow pattern is simple, and the cab seldom handles more than 5 to 7

aircraft at a time. In an uncomplicated situation involving so few aircraft, the cab controllers tend to keep track of the required flight data in their heads. A scratch pad is available for notetaking, and pertinent information is passed from one cab controller to the next by word of mouth. Usually the controller will only use the scratch pad to list the flight numbers of the aircraft under his control. Controllers correlate flight number with the actual aircraft by comparing the sequence of flight numbers on his scratch pad with the actual sequence of traffic and by remembering or noting the correlation between flight number and the physical appearance of the aircraft.

In contrast, at the nation's busiest airports the cabs operate multiple runways, the taxiway traffic flow patterns are complex, and the cabs are routinely involved with 50 to 60 aircraft at a time. There may be , for instance 15 taxiing aircraft , 8 aircraft actively using 4 operational runways, 10 aircraft in queues awaiting takeoff on 2 departure runways, and 20 aircraft on which departure clearances have been received and pretaxi contact with the aircraft has begun. The internal cab flight data system must provide the nonsurveillance data on each aircraft required for traffic management purposes by the 4 or 5 cab controllers in direct contact with these aircraft. In addition, the system must have the capacity to permit controllers to handle traffic surges, both planned and unplanned and must have the flexibility to permit controllers to handle modifications to the established airport traffic flow pattern, both routine and unusual. For example:

Planned Traffic Surge - holiday traffic

Unplanned Traffic Surge - aircraft that cannot land at their original destination airport due to weather.

Routine Traffic Flow Pattern Change - change of runway configuration

Unusual Traffic Flow Pattern Change - the sudden closing of some portion of the airport due to a disabled aircraft that requires the cab to institute a unique traffic flow pattern.

The use of the scratch pad by controllers to record and organize data on traffic under their control and the use of word of mouth to pass all pertinent information between controllers constitute a flight data system that is limited - both in capacity and in flexibility. The flight data system at the busier cabs is based on the flight strip. The flight strip provides:

- a. Flight data on a particular aircraft.
- b. A scratch pad for flight data amendments and pertinent traffic control information.
- c. The controller with a means to organize and reorganize his flight data (i.e., the order of his flight strips to reflect the on-going traffic situation and its changes).
- d. A vehicle for coordination between controllers to replace direct voice communication.

The FDEP provides the cab with strips on IFR departures. Figure 5.3-2 describes the format of these strips and presents two examples of the information printed on these strips by the FDEP system. Spaces 1 through 9 are used by the FDEP system and spaces 10 through 18 are reserved for controller notations as specified by facility directive. Figure 5.3-3 presents the same two IFR departure strip examples used in the previous figure but includes all controller handwritten notations. The notations include:

1. Amendments to the original IFR flight plan (e.g., ANE682 - departure altitude changes from 7000 to 3500 ft)
2. Important flight data underlined (e.g., DL959 - a heavy DC8)
3. Instructions issued to pilots (e.g., ANE682 - make an intersection takeoff from runway 4R at taxiway Charlie)
4. Pertinent traffic information (e.g., DL959 - departed airport at 20 minutes after the hour)
5. Marks that indicate that the controller had carried out some particular action concerning the aircraft, such as issuing the IFR clearance or forwarding information on the flight to Departure Control.

1	2A	5	8	9	10	11	12
2		6			13	14	15
3		7			16	17	18
4							

	<u>TYPE OF INFORMATION</u>	<u>EXAMPLES OF STRIPS</u>	
1	Aircraft identification	ANE682	DL959
2	Revision number	blank	blank
2A	Strip request originator	blank	blank
3	Number of aircraft, heavy aircraft indicator/ type of aircraft/ special equipment	DH6/A	H/DC8/A
4	Computer ID number	600	508
5	Beacon code assigned	4674	4651
6	Proposed departure time	P1335	P2305
7	Requested altitude	70	120
8	Departure airport	BOS	BOS
9	Route, destination, and remarks	BOS COMM1 PSM V3 AUG	BOS COMM1 BOSOX V205 7WQ BDL
10	-		
-	Enter data as specified		
-	by facility directive		
18			

FIGURE 5.3-2. IFR DEPARTURE FLIGHT STRIP  
EXAMPLES OF DATA PRINTOUT



Similarly Figure 5.3-4 shows examples of handwritten strips for VFR departures and IFR/VFR arrivals.

Preprinted IFR arrival strips are usually not available to tower cabs. Exceptions to this generality include:

- a. Those cabs colocated with the TRACON and which obtain the TRACON's FDEP arrival strips at handoff by some means such as a pneumatic tube system.
- b. Those cabs that have a second FDEP unit which provides IFR arrival strips directly to the cab. Due to space limitations, tower cabs equipped with a second FDEP unit are few in number and tend to be located at the less busy airports.

In conclusion, the current internal cab flight data system based on the flight strip, is a system of organized paper handling that is directly managed by the controllers. Thus effort is required on the part of the controllers to operate and maintain it, but it results in an internal cab flight data system that:

- o Can be highly sensitive to the needs of individual controllers and to the needs of the cab
- o Can not fail as a system - at worst the FDEP could fail; in which case controllers would handwrite all of the strips including the preprinted FDEP strips

5.3.1.3 Cab Flight Data Retention System - This element of the cab flight data system is maintained for legal recording and data collection purposes. The legal recording system documents the day-to-day operation of an ATC facility in order to enable the DOT to investigate any traffic incident. The cab tape records all of its control communication channels and retains the tapes for 15 days. If an incident occurs, these tapes provide evidence of the controller-pilot communications pertinent to the incident. However, the cab logs, flight strips, and scratch pad notes which are also held for 15 days are not admissible in themselves as evidence. They do serve to provide the controllers with a means

33R / ANECS14 T

A VFR DEPARTURE STRIP

— AH 572

AN ARRIVAL STRIP

FIGURE 5.3-4. EXAMPLES OF HANDWRITTEN CAB FLIGHT STRIPS

for reconstructing the details surrounding the incident for their testimony. Normally, no special flight strip markings for legal recording purposes are necessary on the part of the controllers; but when the cab supervisor is aware that an incident has occurred or conditions are such that an accident might occur, he may request the cab controllers to more fully document the operation by means of their strips (e.g., more complete timing information).

Data collection is concerned with providing the raw data needed to generate traffic statistics. These statistics are used to evaluate the performance of the current ATC system for planning purposes. The data collection primarily consists of taking traffic counts and noting delay times. Traffic counts are obtained in a number of ways, two of which are having Flight Data count the completed flight strips for each hour, or having the controllers use mechanical counters and recording their totals each hour. To obtain delay data, controllers will note on the flight strip the time an aircraft begins and ends its delay.

### 5.3.2 FDEP Functional Aspects

5.3.2.1 Physical Description - The Flight Data Entry and Printout (FDEP) system's main function is to accept and print flight data information on flight strips. It also selects the appropriate printer within an ATC facility and adjacent facilities and responds to request messages and input errors.

The FDEP equipment is comprised of a Data Communication Control Unit (DCCU), a keyboard, and a Flight Strip Printer (FSP). The DCCU controls the flow of data from the ARTCC computer from the keyboards and to the flight strip printers (Figure 5.3-5). It also controls the functioning of the keyboards and printers and responds to error messages. The DCCU, which is located in the TRACON, can operate three printers and two keyboards. The keyboard has 26 alphabetic keys, 10 numeric keys, 7 function keys, and upper and lower special characters (Figure 5.3-6). Figure 5.3-7 explains the function keys and special characters. The status lamps (Figure 5.3-8) indicate which inputs the keyboard expects or which functions are currently being processed.

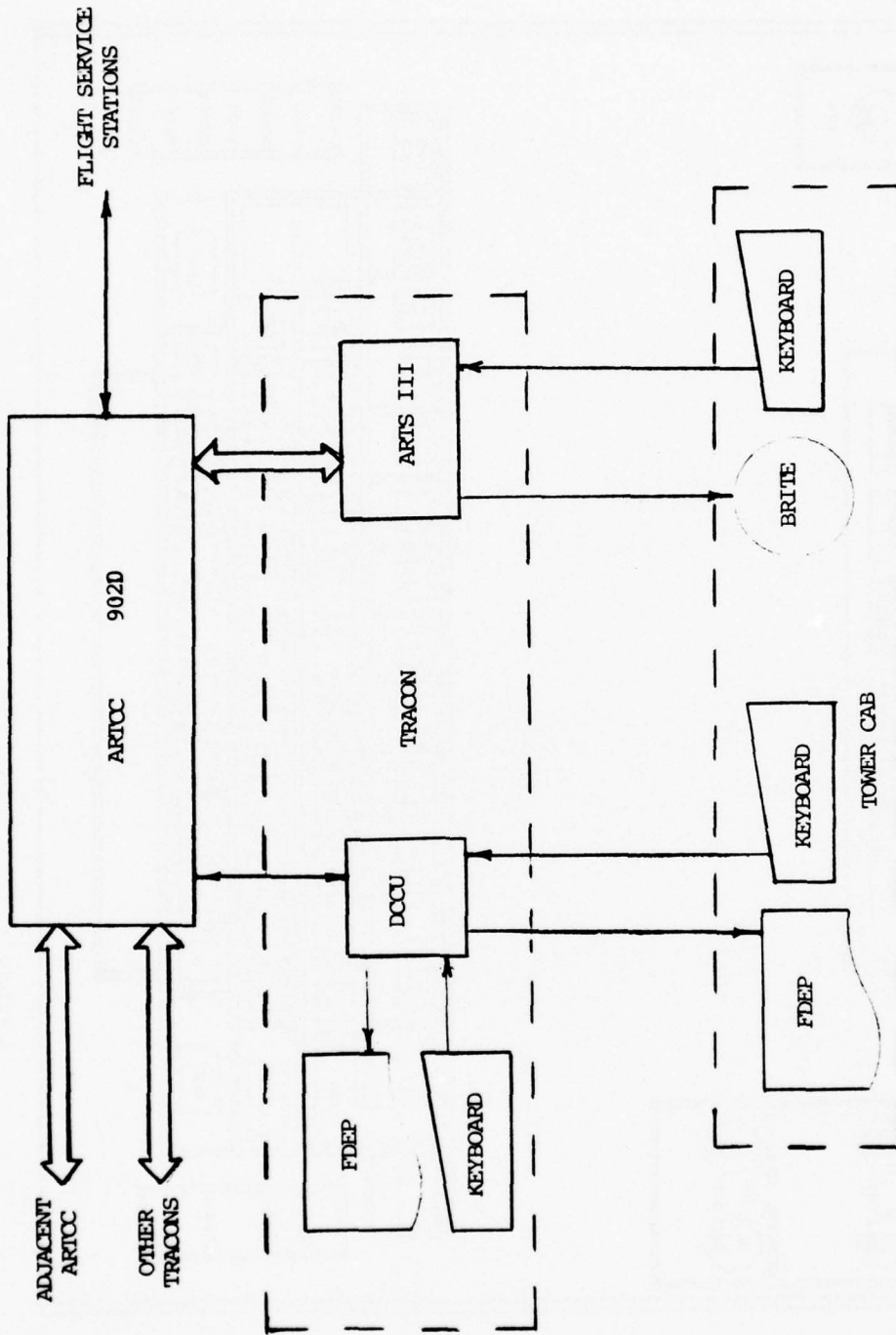

FIGURE 5.3-5. PRESENT FDEP INTERFACES

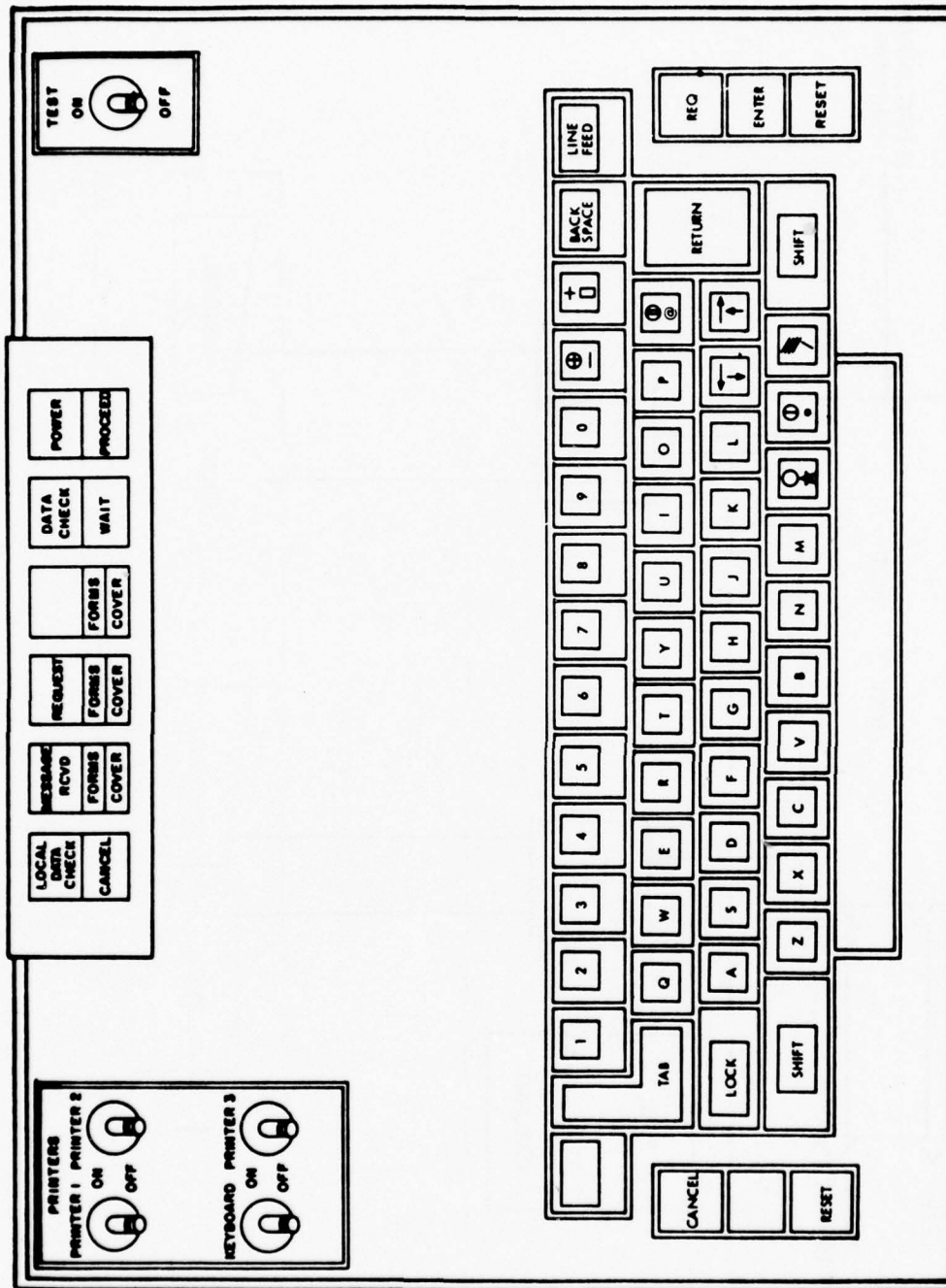

FIGURE 5.3-6. FDEP ALPHANUMERIC KEYBOARD<sup>1</sup>

26 alphabetic keys

10 numeric keys

The 7 function keys are as follows.

1. Space (unlabeled)
2. Backspace
3. Line Feed
4. Return (carrier return and line feed)
5. Tab (horizontal tabulation)
6. Shift (case shift)
7. Lock (case shift lock)

LOWER CASE	UPPER CASE
• - Period, used in lieu of spaces to separate items in the route of flight (i.e., JAX.V51)	⊙ - Weather symbol for scattered clouds.
↓ - "Down" arrow.	→ - East arrow.
☆ - Open star.	○ - Clear weather symbol used to denote Remarks in flight data.
↑ - "Up" arrow.	← - West arrow.
▭ - Vertical rectangle. An error indication.	- Plus sign.
- - Dash; not used.	⊕ - Weather symbol for overcast sky.
@ - Commercial at; not used.	⊝ - Weather symbol for broken clouds.
/ - Slant, used to separate certain groups of flight data items.	/// - "Cancel" symbol.

FIGURE 5.3-7. ALPHANUMERIC KEYBOARD

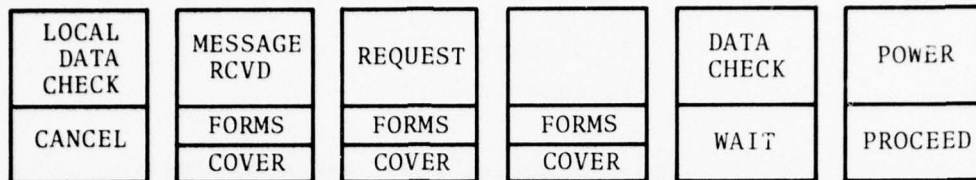

### Status Lamps

CANCEL	cancel message
DATA CHECK	error in message, should cancel message
FORMS-COVER	out-of-strips or cover is open
LOCAL DATA CHECK	error in FDEP terminal, cancel message
MESSAGE RCVD	received last message
POWER	power on
PROCEED	keyboard unlocked, begin message
REQUEST	request message, awaiting poll of keyboard
WAIT	FDFP equipment waiting for computer response

FIGURE 5.3-8. STATUS LAMPS<sup>1</sup>

The flight strip printer provides a review of keyboard messages before entry into the system and prints flight data updates and computer responses as well as flight strips.

5.3.2.2 Flight Strips and Message Handling - The flight strips printed at the tower or TRACON are called, respectively, tower and approach control strips. The purpose of the strips is to present the tower and TRACON controllers with pertinent flight plans and updates for arrivals and departures. There are three basic formats

- a. departure strip (Figure 5.3-9)
- b. overflight strip (Figure 5.3-10)
- c. arrival strip (Figure 5.3-11)

These strips can be printed at the tower FDEP, the approach control departure FDEP, the approach control arrival FDEP, or the approach control overflight FDEP printers. Any requests for enroute strips are printed in the tower and approach control formats.

The original flight plan must contain the flight identification, aircraft data, speed, coordination fix and time, requested altitude, and route data. The beacon code and remarks are optional. Flight plans may be filed with the nearest Flight Service Station, airline office, or military base. The ARTCC computer receives inputs from the ATC facilities via interfacility data channels and enters the flight plans into the system for processing or future reference.

FDEP printers can be used in towers or approach control facilities in any of the following ways:

A tower printer can be adapted to receive departure strips only, arrival strips only, or both departure and arrival strips. Up to four FDEP printers can be specified as departure printers and up to four as arrival printers for an adapted airport within an approach control facility.

1	2	3	4	5	6	7	8	9	10/9																						
9	11	13	15	17	19	21	23	25	27	29	31	33	35	37	39	41	43	45	47	49	51	53	55	57	59	61	63	65	67	69	71

1. Aircraft Identification
2. Revision Number
- 2a. Strip Request Originator on an SR
3. Number, Heavy Jet Indicator/Aircraft Type/Special Equipment
4. Computer Identification Number
5. Mode 3/A Beacon Code
6. Departure Time
7. Altitude
8. Departure Point
9. Route Information
10. Remarks

FIGURE 5.3-9. TOWER AND APPROACH CONTROL DEPARTURE STRIP<sup>2</sup>

1	3	5	7	9	11	13	15	17	19	21	23	25	27	29	31	33	35	37	39	41	43	45	47	49	51	53	55	57	59	61	63	65	67	69	71
1			5		8		9																												
2	2a		6		9a																														
3			7		9b/9a																														
4	4	a																																	

1. Aircraft Identification
2. Revision Number
- 2a. Strip Request Originator on an SR
3. Number, Heavy Jet Indicator/Aircraft Type/Special Equipment
4. Computer Identification Number
- 4a. Duplicate Strip Indicator
5. Mode 3/A Beacon Code
6. Coordination Fix
7. Overflight Coordination Indicator
8. Calculated Time of Arrival at Coordination Fix
9. Altitude
- 9a. Route Information
- 9b. Remarks

FIGURE 5.3-10. APPROACH CONTROL OVERFLIGHT STRIP 2



The FDEP printer can be adapted as the overflight printer for the facility.

Only one FDEP printer can be specified as a departure and arrival printer for an adapted airport not within an approach control facility.

All tower and approach control strips are scheduled for printing based on coordination fix time. That is, strips are scheduled to be printed according to the time over the coordination fix.<sup>2</sup>

When an output message intended for an FDEP printer is unsuccessfully transmitted to that printer, the message is automatically rerouted to an alternate printer which may or may not be associated with the same DCCU. If an output message cannot be successfully transmitted to either a primary printer or the associated back-up printer, an Unsuccessful Transmission Message (UTM) will be output to an Input/Output Terminal (IOT) after the total number of message re-tries is completed with respect to both printers.<sup>3</sup>

### 5.3.3 Current Problems/Tower Cab Flight Data System

In 1974, the FAA held a national conference concerning flight data handling in the terminal area.<sup>3</sup> As a part of that conference, Air Traffic and Airways Facilities representatives from the various regions presented papers, which, in part, described the data handling problems being experienced by the cabs and TRACONS in their regions. The following discussion is a composite of the views expressed at that conference.

Three distinct but interrelated systems in the tower cab are involved with aircraft flight data - the cab interface with the nationwide flight data system, the cab flight data system which provides Ground and Local Control with traffic management data, and the cab flight data retention system. The cab interface with the nationwide flight data system is based on the FDEP and primarily involves the relaying of clearance delivery. Two problem

areas were highlighted concerning this system - the FDEP itself, and the ARTCC's limited capability to handle non-IFR flight data.

At the busier airports, the FDEP is operated near capacity and at times will fall behind causing clearances to be delayed. The FDEP is a relatively complicated electro-mechanical device with many moving parts and many inter-related adjustments. High utilization of the device causes excessive wear which results in a high rate of failure, and the complexity of the device makes maintenance both difficult and time consuming.

The FDEP system is convenient for handling VFR flight data and clearances, such as special VFR (SVFR) clearances, which permit VFR aircraft to operate within control zones in weather conditions that are below the basic VFR minimums. This problem is more acute within Terminal Control Areas (TCA), because flight data for each VFR aircraft must be entered into the ARTS computer in order to get a TCA clearance and a discrete beacon code. This data entry workload falls on the controller since VFR aircraft are not routinely handled by the NAS Stage A Flight Data System. For those cabs within a TCA that are not co-located with the TRACON, the workload of entering the VFR flight data into the ARTS computer has fallen on the TRACON if the cab has no FDEP, and on the cab if the airport is large enough to qualify for an FDEP. In the latter case, the flight data is entered via the FDEP into the ARTCC computer, which automatically relays the information to the ARTS computer. Cabs co-located with TRACONS are equipped with an ARTS keyboard which at some airports replaces the FDEP for ARTS flight data entry. The addition of the ARTS keyboard provides the cab with the same ARTS interface as a TRACON control station. The keyboard is the communication link from controller to computer, and the large ARTS display is the communication link from the computer to the controller. This interface was designed for the TRACON control station, where the input and output channels are co-located. In the tower, however, the TCA clearance and beacon code assignment are requested via the Clearance Delivery/Flight Data station, but are presented on the ARTS BRITE display located at the Local Control station.

The LC station can be widely separated from the CD/FD station. Putting another ARTS BRITE display in the cab at the CD/FD station is not a satisfactory arrangement because of the display's large size and cost and the fact that Clearance Delivery/Flight Data use only the small keyboard message preview area on the display. Some airports have been experimenting with smaller displays.

The second flight data system in the cab is the one that provides Ground and Local Control with the flight data they require for traffic management. It is based on the FDEP strip, the handwritten strip, the scratch pad, and more recently the A/N BRITE. The problems associated with this system as presented at the conference had to do with the flight strip, its storage, routing, and modification. At the busier airports, the storage and distribution requirements involved in handling the large number of flight strips put a strain on the limited space available in the cab. Strip routing can be awkward and distracting for controllers. The large size of the FDEP, which constrains its location in the cab, was identified as the biggest problem to be overcome in establishing a good strip distribution pattern. Further complicating the establishment of satisfactory strip distribution patterns is the requirement to provide secondary strip routes in the cabs. Secondary routes are necessary to permit control positions to be combined operationally and to permit coordination between controllers during the process of amending their flight strips.

The third flight data system in the cab, the data retention system, was barely mentioned at the conference. The demands of this system on the controller appeared to be modest and created little concern.

#### 5.4 AIR/GROUND COMMUNICATIONS

##### 5.4.1 Physical Description

ATC air-ground communications are carried out by voice radio. Frequencies assigned for this purpose lie in the VHF band (118.00 - 135.95 MHz) and the UHF band (225.00 - 400.20 MHz). The UHF frequencies are used primarily for communicating with military

aircraft. The VHF frequencies are used for communicating with civil aircraft, as well as with military aircraft having VHF equipment when they operate at civil airports or in Terminal Airspace.

Installed equipment tends to differ from facility to facility, since each configuration was generally developed in an evolutionary way, with changes and additions made at various times in response to changed needs.

The terminal air-ground communications systems are usually located at or close to the airport complex in facilities designated as remote transmitter receiver (RTR) facilities. The RTR houses the air-ground transmitters and sometimes the receivers. The air-ground equipment is connected from the RTR to the control tower complex both by commercial telephone lines and by direct FAA-owned cables. Usually, the air-ground VHF and UHF receivers (and one-for-one standby equipment) are installed in the control tower equipment room and connected to their respective antennas located either on or adjacent to the control tower roof. The antennas for both frequency bands are omni-directional. Each transmitting antenna is connected through a switching relay to either the main or standby transmitter. The receivers usually share antennas, with three receivers multicoupled through a branching amplifier to one antenna.

Air-ground communications are required for every controller position in the tower cab and TRACON. Each position has VHF/UHF selector panels that can select individual or combinations of VHF/UHF for simultaneous transmission. (One reason for using simultaneous VHF/UHF transmission is that both the military and civil aircraft worked by one controller can hear not only their own instructions but those directed to the others as well.

Selection of transmitter and receiver channels is made through channel control equipment. The receiving control equipment permits the controller to select from one to four radio channels, using an individual selector panel installed at his position. One to five control units are generally installed at a position. The

equipment consists of a receiver selector and mixer panel with volume controls for both the earphones and speakers. Also included on the selector panel is a neon light indicator above each of the four selector switches which indicates when an audio signal is being received. The transmitting four-channel control equipment provides a similar capability to conform with the receiver selection. Selection of a transmitter is made by flipping one of the four selector switches. A dim light above the channel indicates an idle channel while a bright light indicates a channel in use. More than one position may have access to a channel. A buzzer alarm will sound if a channel already in use is selected.

#### 5.4.2 Frequency Assignment

The overall VHF aeronautical mobile communication band (118.00 - 135.95 MHz) is defined by international agreement. The United States has a national suballocation plan for this band which assigns various frequencies within it to purposes other than ATC, leaving a total of 253 50-kHz channels in three distinct bands for ATC use. Aircraft have blanket authority to use any of these, and select the frequency according to the ground station with which they are communicating. Assignments of channels to ground facilities are made by the FAA.

VHF and UHF radiation propagates along line of sight. Thus the same frequencies can be assigned to a number of ground sites that are sufficiently separated. The separation necessary varies between 20 nautical miles for ground control functions with a nominal transmitter range of 5 nautical miles and 610 nautical miles for the high-altitude ATC functions with a nominal range of 150 nautical miles. The separation requirements are calculated on the basis of a protection ratio of 14 dB, i.e., a ratio of desired to interfering signal of 14 dB. In 1975, the need for VHF channels for ATC purposes was estimated to be more than 5600, and the number has been steadily increasing, indicating that frequency congestion is a problem that needs to be considered.

The problem is aggravated by the fact that a substantial portion of general aviation aircraft can tune only to those frequencies at XXX.X0 MHz, i.e., not to the channels with frequencies of odd numbers of 50 kHz - XXX.X5 MHz. These channels therefore are not fully utilized.

#### 5.4.3 Operation

Air-ground communications are required at every position in the tower cab and TRACON. The number of positions varies with the air traffic activity and complexity of the terminal air space.

Generally, before leaving the gate position, an aircraft pilot receives clearance for the flight by the clearance delivery controller on the clearance delivery air-ground frequency; the pilot then switches to a ground control frequency and the ground controller clears the aircraft to the departure runway. The pilot then switches to the local controller on the appropriate frequency; the local controller clears the aircraft for takeoff. After takeoff, the local controller hands off the aircraft to the TRACON departure controller and assigns the aircraft a departure control communications frequency. The departure controller maintains contact with the aircraft until it reaches the point at which it is handed off to the en route center and assigned an air-ground communications frequency. Essentially the same sequence of successive handoffs and frequency changes is undergone by arrival flights in reverse order, except that the clearance delivery function does not apply.

#### 5.4.4 Automated Terminal Information System (ATIS)

As part of the air-ground communications capability, an Automated Terminal Information System known as ATIS is installed at high activity and other selected airports. This system continuously transmits pre-recorded terminal area information (wind direction, altimeter setting, runways in use, NOTAM bulletins, and other data relative to airport conditions). Some terminals

use the VOR for transmitting ATIS information and others use a separate VHF/UHF channel. The recording and playback equipment is installed in the tower and connected to the transmitter by audio lines. The recordings are made by the tower personnel. Messages are generally on the order of one minute in length. The purpose of ATIS is to relieve controllers of the need to transmit the repetitive information on their control frequencies.

The ATIS messages are identified by letter designations, changed each time the message is updated. Pilots identify the latest ATIS message they have heard to the controller by this letter, and can be instructed to listen to the new ATIS message if a change has been made.

## 5.5 DATA PROCESSING AND DISPLAY SYSTEMS

### 5.5.1 Processing and Display Systems

The primary objective of the data processing and display subsystems in the ATC system is to present to the controller a picture of the environment in which the air traffic he has under his control is located. The secondary objective is to supply, in a useful and timely fashion, information about that traffic, such as aircraft identifications, and about the environment, such as altimeter setting. Tower cabs of different sizes have been supplied with these systems in various forms ranging from displays of raw video from primary and secondary radar through the TPX-42 to ARTS III displays. In TRACAB configurations, the entire processor-display system is associated with the tower operation, while in tower-TRACON configurations, the processor and most of the displays are located in the IFR room, with one position assigned to the tower.

As newer equipment is delivered, it is FAA policy to move older but still serviceable equipment to previously unequipped airports. Thus, a survey of airports from small to large reveals not only a range of equipment from simple to complex, but also a quasi-historical view of the development of ATC processing and display systems. The exception is the ARTS II system which is the

newest system to be considered here, but which is less capable than the ARTS III system and is meant to be deployed in lower activity terminals.

A simplified representation of the displays from the four systems discussed below is given in Figure 5.5-1.

5.5.1.1 Radar-only Systems - The earliest and simplest ATC processor/display systems present to the controller a view of the surrounding airspace on a Plan Position Indicator (PPI)\* scope. Both primary, or reflective, and secondary, or beacon, returns are displayed at positions corresponding to the location of the target in space. The only 'processing' involved is the introduction of a delay in the painting of the primary return to compensate for the delay introduced in the secondary return at the transponder, so as to cause the two returns to be displayed at the same range.

Over the years, a number of controls and features have been added which make the display easier or more convenient to use or which interpret the information implicit in the beacon signal and make it available to the controller. Among the controls and features are:

a. Off-center and range control, which allows the suppression of unwanted coverage with increased resolution over the coverage displayed.

b. Zero-range adjustment, which allows a check on whether or not a given beacon return corresponds to a primary return, or is possibly not a true target - a reflection or side-lobe return - in case there is no corresponding primary.

c. Beacon-code filter, which can modify the beacon return in a number of ways, both simplifying the display and presenting more information on it. For instance, the first bracket pulse

---

\* See Appendix A for discussion of PPI.

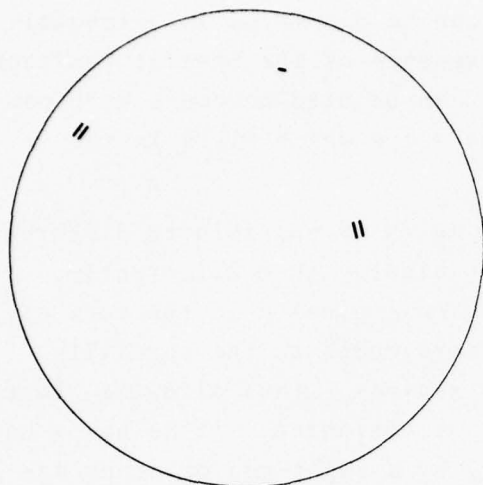

a) RADAR ONLY

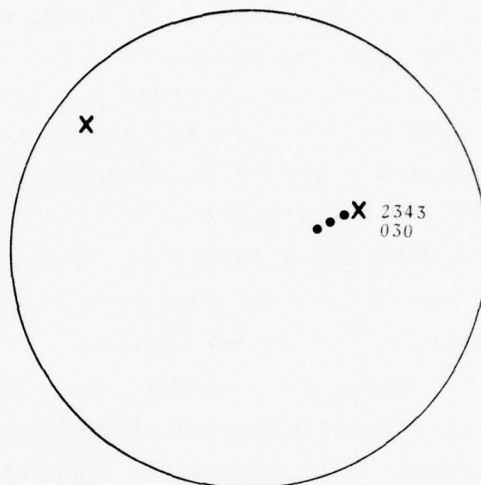

b) TPX-42

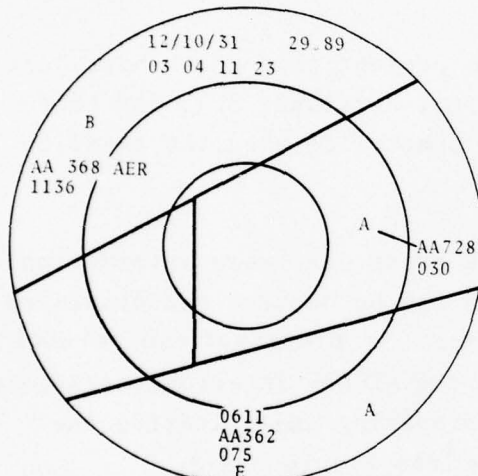

c) ARTS II

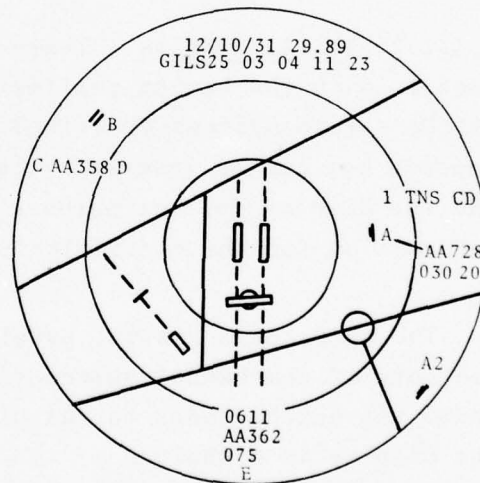

d) ARTS III

FIGURE 5.5-1. REPRESENTATIVE DISPLAYS FROM FOUR SYSTEMS

can be displayed and the rest of the pulse chain suppressed. Special codes, such as 7600 and 7700, can be displayed in a special way, say with three slashes. The presence of the Special Position Indicator (SPI) - the "ident" bit - can be used to cause a "blooming" of the target indication on the scope which fills in the space between the slashes.

d. Beacon-code decoder, which makes it possible to differentiate between groups of codes and to display them differently. If the controller is given an input device - usually in the form of thumbwheels - he can select one or more codes to be specially treated - say by the display of two slashes - thus allowing him to follow targets with far less chance of confusion. If he has a way of denoting a target on the display, by a light-gun or other device, the actual code used by that aircraft can be displayed on an auxiliary read-out device.

There are systems in use at the present time which have just the capabilities described above (e.g., Portland, ME), and these systems will adequately support the controller when the traffic load is light.

5.5.1.2 TPX-42 Systems - There is a great deal more information contained in the beacon replies than can be decoded and displayed by the simple systems described so far. A processor and related control box can be inserted between the ATCRBS Interrogator/Receiver and the display for the purpose of preparing and filtering the information for the controller's use.<sup>4</sup> See Figure 5.5-2.

The operator's control panel has two sections: a group of ten sets of thumbwheel switches and press switches used to select up to ten beacon codes for display and a set of switches to control the display as a whole.

For each of the ten beacon codes, the operator may select one of three kinds of display: 1) he may cause a center mark symbol, an x, to appear for each target reply which has the same two first digits as selected; 2) he may in addition, cause the beacon code for each of those targets to appear near the center mark in

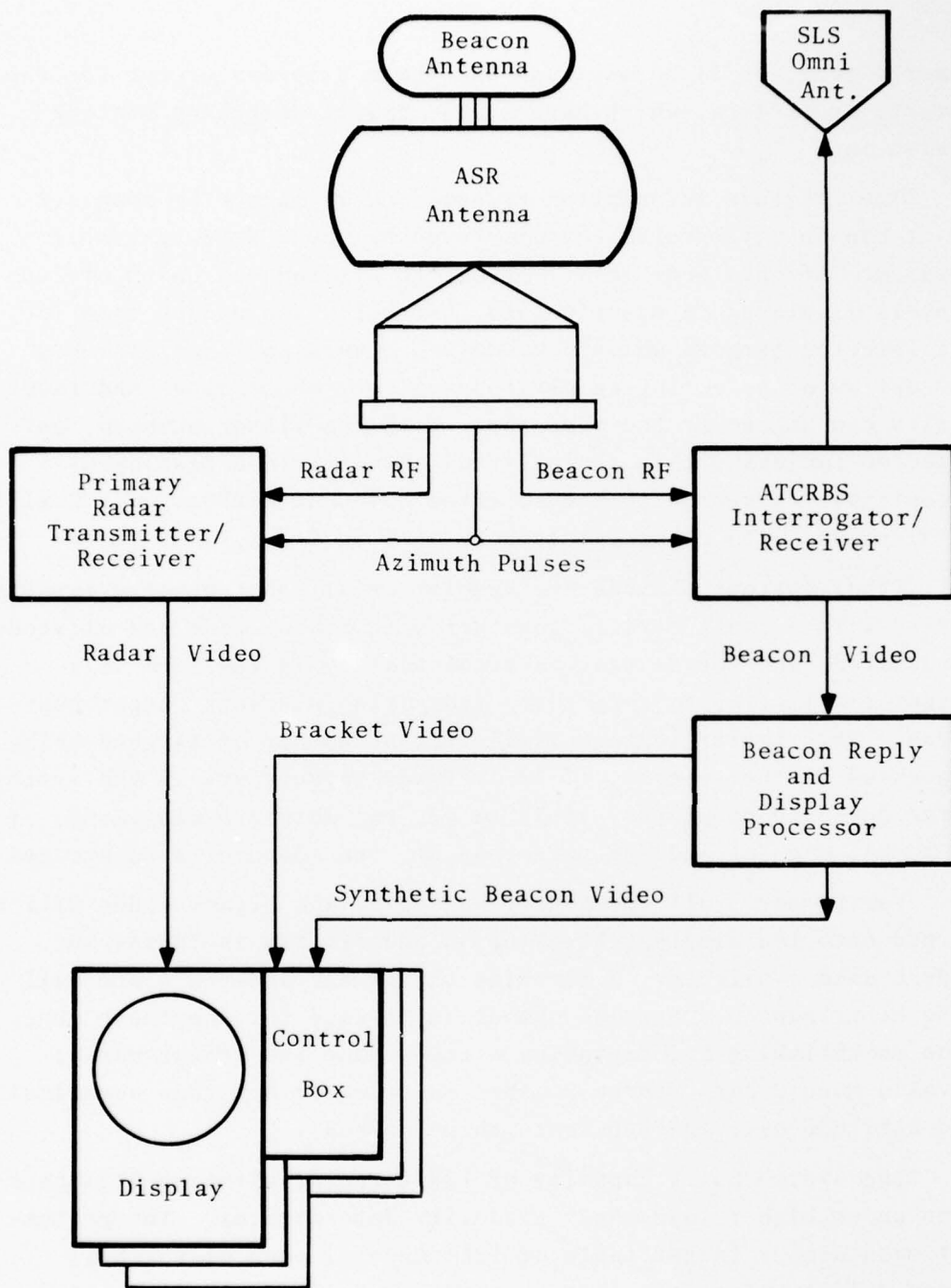

FIGURE 5.5-2. TPX-42 SYSTEM BLOCK DIAGRAM

numeric form; or 3) he may suppress those displays except for the target, or targets, which have a code exactly matching the one dialed in.

The altitude information transmitted in mode C by some aircraft can be interpreted and displayed by the TPX-42 system if desired. If this mode is selected, the altitude in units of 100 feet is displayed in numeric form just below the beacon code for all selected targets which have mode C. Each position also has the option of selecting an altitude filter, whose upper and lower limits can be set by the operator. With the filter enabled, only selected targets within that altitude band will be displayed, except that targets with the selected code but without mode C will be displayed with a special symbol, an x in a box.

Other options include the display of all non-selected targets, marked with a small circle, together with beacon code and altitude, if desired, and the display of track history in the form of a target trail of up to three dots indicating previous target positions. This latter feature is limited by number of targets being processed in the system: if 32 or fewer targets are in the system, three dots are displayed, if 33 to 42, two dots are displayed, if 43 to 64, one dot and for more than 64, the feature is suppressed.

Furthermore, all Emergency, No Radio, and Hijack codes will be forced onto the display, blinking on and off and including any Mode C data available. A flashing signal and audible alarm will also be triggered. Special symbolism is used for the Ident function (a shrinking and expanding circle about the center mark), invalid Mode C data (three slashes in place of altitude numerics) and altitude over 100,000 feet (three dashes).

The system has a capacity of 128 targets, although its operation under higher loads only gradually deteriorates. The processor maintains a target table of 128 targets, each of which is dropped just before the next radar reply is due and reinitiated with its new coordinates after the reply is decoded. If more than 128 targets are being processed, the newest target received is written over the oldest one in the table, thus effectively dropping

the TPX-42 and the ARTS III systems.

The ARTS II system is composed of three subsystems: the Decoding Data Acquisition Subsystem (DDAS), the Data Processing Subsystem (DPS) and the Data Entry and Display Subsystem (DEDS), these are shown in Figure 5.5-3, taken from the ARTS II specification, in a TRACAB configuration.<sup>5</sup> The DDAS receives the target data from the ATRBS and triggers azimuth data from the radar. It converts the signals to digital form and passes the resulting target data list to the DPS once for each sweep of the radar. At the same time, the beacon video signal is decoded and filtered and passed to the DEDS in much the same way as in the radar-only system described above. This capability is retained as a backup in case of failure in the digital portions of the system.

The DPS has a number of functions to perform, some of which are not feasible in systems not containing a general-purpose computer. The four basic functions performed are: the processing of beacon data to produce target positions with associated codes, altitudes and associated data (SPI, emergency, etc.); the processing of inputs from keyboards, other facilities, etc.; the association of flight-plan data with the target data and the preparation of alphanumeric and synthetic PPI display tables for output to the DEDS. The first and last types of processing are already being accomplished in the TPX-42 systems, although obviously not in the same way they are done here. The computer in the DPS may be programmed to do a great deal of special processing to handle special, unusual circumstances, such as ring-around, split targets and false targets in beacon data processing, and to provide more complex displays with more options for the operator to modify the display for his use, as will be shown below.

In general, messages which come from other facilities contain flight plan data, while messages which come via the keyboards contain either flight plan data or display control data. Thus, the input processing task supports maintenance of the flight plan data or of the display processing task. In turn, the flight plan data is correlated with the beacon target data and used to generate

it early. Since it is the oldest target, it will be the next one seen by the antenna of the targets currently in the list, and if there are not many more than 128, the time between drop and reacquire will not be excessive.

There are a number of provisions in the system to back-up equipment failure, although there has been no conscious effort to provide a fail-safe capability. Both the Interrogator/Receiver unit and the Azimuth Pulse Generator Unit are supplied in pairs, selectable from the control panel at the displays; otherwise the system is single channel. If the display processor portion of the system fails, bracket video signals, which are regularly available during normal operation, can be switched on. Finally, the primary radar video is always available to back up the beacon system.

Data processing in the TPX-42 system is restricted to the two functions, target detection and display generation. Both are done in handwired processors each dedicated to the one task. The beam-splitting technique used in the Beacon Reply Processor converts a string of mode 3/A and mode C hits on a target into a single range-azimuth pair representing the target location, a beacon code and an altitude, plus any associated data (e.g., Special Position Indicator). The Display Processor converts this information into display deflection voltages, timing pulses and signals to produce numerics and symbols on the displays. Note that the synthetic portion of the display is limited to numbers and a small number of symbols, only.

5.5.1.3 ARTS II Systems - Although the ARTS II system is not operational at this time,\* and although the ARTS II system will be the subject of a more extended treatment as an element of the UG3RD system (Section 9.1), a brief description of its capabilities will be included here because it fits so well functionally between

---

\* Except for one of the original Lockheed-built systems installed at Wilkes-Barre, PA.

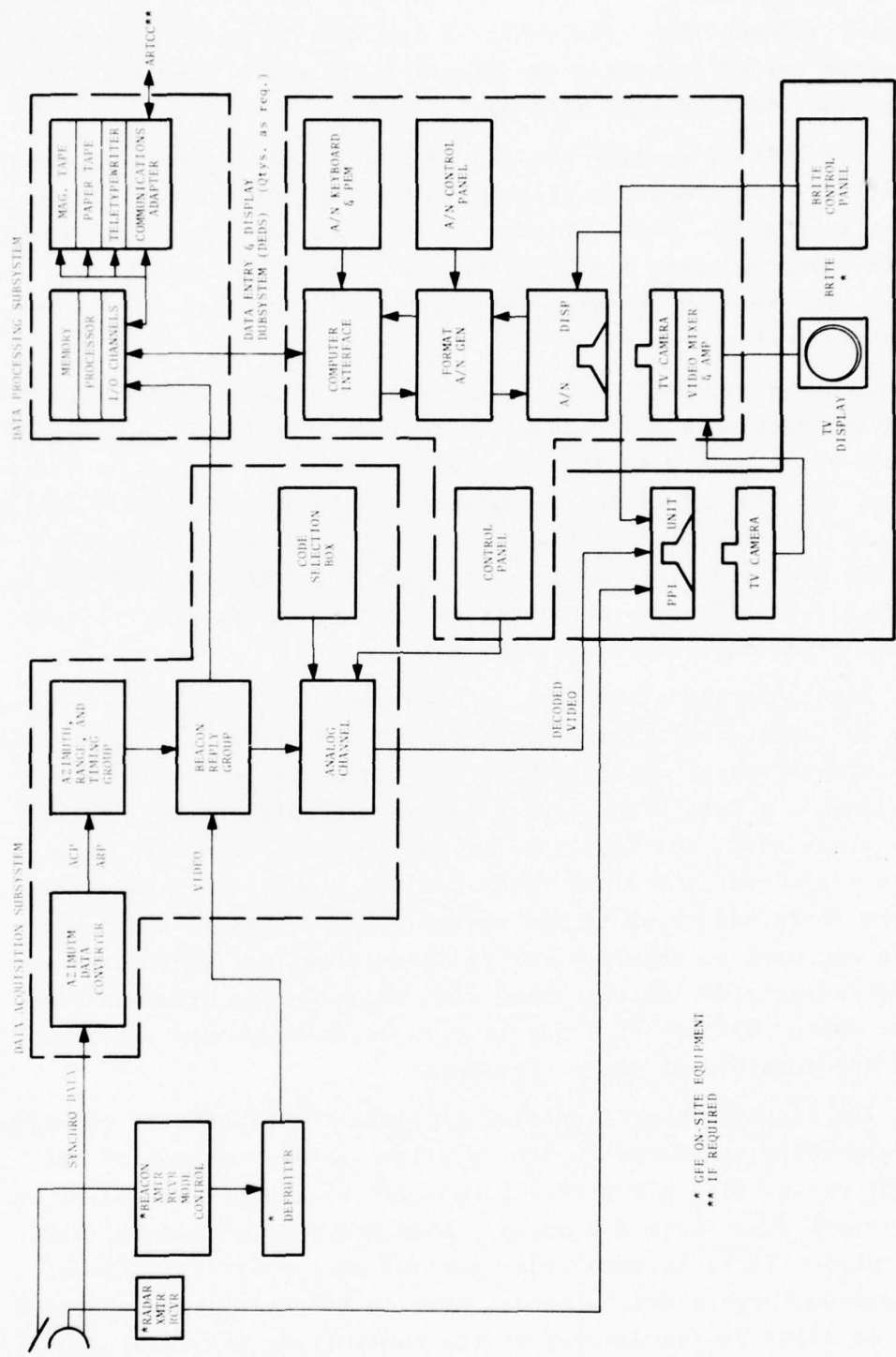

\* SEE ON-SITE EQUIPMENT  
 \*\* IF REQUIRED

FIGURE 5.5-3. ARTS II TRACAB CONFIGURATION

display information. The whole of the ARTS II system, then, is directed toward providing the display with which the controller works and toward making it a useful tool.

The ARTS II display has nearly all of the features of the TPX-42 display (the past history feature is not available) plus a great many more. Three classes of features will be discussed here: those concerned with filtering the data, those affecting the data block and the tabular data, and those concerned with the flight data and system operation.

Control of the display is effected by hard-wired switches, function buttons and alphanumeric keys on a keyboard, and a positional entry module (PEM). Control of the video signal is independent of the control of the alphanumeric data and is roughly equivalent to the operation of the TPX-42 described above, with the notable addition of gain controls which allow the operator to bring up on his display: a) a compass rose, b) range marks every two, five, or ten miles, or c) a video map.

Alphanumeric information is displayed in two forms: tabular data (discussed below) and track data. The track data may consist of a single symbol, displayed at the beacon target location, or the symbol, a data block, and a leader connecting them. A full data block (FDB) has two lines of up to seven characters each, while a limited data block (LDB) has two lines, four characters in the first and three in the second. The distinction is that FDB's are used to supply aircraft identifications (ACID) for so-called associated targets along with altitude and other information, while LDBs are used for targets which have only a beacon code and possibly altitude available.

The target symbol displayed is either an alphabetic character corresponding to the controller position having control of the flight or one of a group of alphanumeric characters depending on the target type (selected or not, mode 3/A only or mode C, VFR, en route). Those targets under control of a position will be associated targets and hence can have an FDB displayed. The FDB will be shown on the display at the controlling position, and may

be shown at other displays if they choose to use the 'quick-look' feature. Each display has a set of quick-look switches, one for each other position, whose activations cause FDB's to appear next to target symbols of the other positions.

The unassociated targets within range of the radar appear on the displays as single symbols coded by type and subject to filter selections through switch settings or keyboard message entries. The filters are the usual ones: display all codes, display selected codes, altitude limits and override.

The data blocks themselves can be modified or moved to suit the needs of the individual. Selected fields in the FDB can be suppressed by a keyboard message, and the position of the data blocks relative to the target symbols can be changed to any of eight directions, with one of eight leader lengths.

There are three types of tabular data displayed on the scope; the location of the data is under the control of the operator. There is a preview area which displays the keyboard entry message until the operator is satisfied that it is correct. There is a system data area in which are displayed the current time and altimeter setting. Finally, there is the aircraft tabular list which holds flight data on arriving or departing aircraft not yet in the system and aircraft with which contact has been lost for about 20 seconds or more. Entries in the aircraft tabular list may come from keyboard entries, pre-stored flight data, or messages from other facilities.

The controller has the capability to create, modify and/or delete flight data in the aircraft tabular list and in the FDBs through operation of the keyboard and PEM. In addition, a group of acquisition points and drop areas for arrival, departure, and en route flights may be selected from a prestored set, thus reconfiguring the system. The acquisition points and drop areas are used by the system to acquire or drop flights automatically, relieving the controller of that task. Finally, the capability is provided for the handoff of targets from one controller position to the next in a simple and natural way.

5.5.1.4 ARTS III Systems - The ARTS III system is not really a tower system (it never appears in TRACAB configuration, for instance), although it does interface with the tower cab through the BRITE display and ARTS keyboard which make up the ARTS 'tower' position. The controller has available to him in the ARTS III system at least the functions of the ARTS II system described above, and more.

The most apparent additional capability possessed by the ARTS III system is tracking of the radar targets, in the process of which current velocity is calculated and made available for display. Thus, the data blocks on the displays give the controller position, identity, altitude and velocity of the target aircraft. A recent patch to the system allows the time-sharing of the velocity field of the data block between the velocity and the aircraft type according to site-adapted parameters, e.g., speed displayed for 5 seconds followed by aircraft type for 2 seconds. The tracking algorithm also is capable of maintaining correlation of target and identity in the presence of heavy traffic and poor conditions.

#### 5.5.2 TRACAB Configurations

A tower cab that has within it the radar approach control positions is called a TRACAB. Radar-directed approach and departure control are possible with only the minimal equipment described above if the situation is simple and the traffic is light. The controller must identify each target on his scope with an actual flight and keep this identity clearly in mind during the whole operation. He must also observe the relative locations of the targets to each other, to the runway, and to various hazards which might exist (towers, shipping, mountains, etc.). On approach, he must direct the aircraft to the final approach fix in such a way that it remains clear of other aircraft, and then make the handoff to the local controller, who may or may not have access to a radar presentation of his own. On departure, the controller must pick up the target at the departure fix and guide it to its proper outbound course.

5.5.2.1 TPX-42 Systems - As the number of targets increases, the ability of the controller to remember the identities of all the targets in his area of responsibility may be exceeded, so an aid in the form of numeric tags on the targets is a necessity. For use in a TRACAB, the TPX-42 must be combined with a BRITE display system and should drive at least three positions: Approach Control, Departure Control, and a 'tower' position.

Association of beacon code and aircraft identification is still a function that the controller must do for himself, but the display allows him to monitor the positions and altitudes of the aircraft relative to each other and observe potentially dangerous situations in time to do something about them.

5.5.2.2 ARTS II Systems - The ARTS II system in a TRACAB configuration supplies the capability to associate the aircraft identity (ACID) with the beacon code, either automatically by means of pre-filed flight plans or as the result of controller action. This association is carried along throughout the approach or departure until dropped automatically at preset points.

The interface between Local Control and Approach or Departure Control remains the voice channel and, secondarily, the BRITE display. In theory, Local Control can get all the information on his display which is available on the approach control display, but the realities of the poor resolution of the scope and its distance from the LC station reduce its effectiveness.

The data processing functions that actually have an effect on operations by the local and ground controllers are the generation of the BRITE display and the processing of inputs via the tower position keyboards, most of which have to do with modifications to the display.

### 5.5.3 Tower/TRACON Configurations

In tower/TRACON configurations, that is, when approach control is not located in the tower cab, the processing systems described above will only marginally affect tower operations. The

same interfaces exist but the lack of physical proximity introduces a rigidity into the relationship. The same ARTS II or III tower position exists with a BRITE display and keyboard and it is used in about the same way. Communication between Local Control and Approach-Departure Control will be by voice, as before.

## 5.6 WEATHER-RELATED SYSTEMS

This section describes the current tower cab equipment and procedures dealing with the collection, processing and dissemination of weather and airport hazard information. Besides the usual weather elements, the discussion includes present procedures for handling wake vortex and wind shear phenomena and runway selection. The descriptions are based on tower cabs in medium and large hub airports. Because the equipment and controller complement varies substantially, even among towers at comparable airports, it is not possible to draw accurate conclusions regarding any one tower from these descriptions. Nevertheless they serve to typify tower cab weather and airport hazard equipment and the procedures under which the equipment is used at large and medium hub airports. Non-approach control towers, and approach control towers at small and non-hub airports, usually contain a subset of the equipment and procedures described here.

### 5.6.1 Equipment

The major equipment and data sources employed in weather and airport hazard warning systems are illustrated in Figure 5.6-1 and may be classified as follows:

#### WITHIN TOWER

- a. Altimeter Setting Indicator (ASI)
- b. Wind Speed Indicator
- c. Wind Direction Indicator
- d. Telautograph/Electrowriter
- e. RVR/RVV Indicators
- f. Ceilometer Indicator
- g. ATIS Equipment
- h. Clock

#### OUTSIDE TOWER

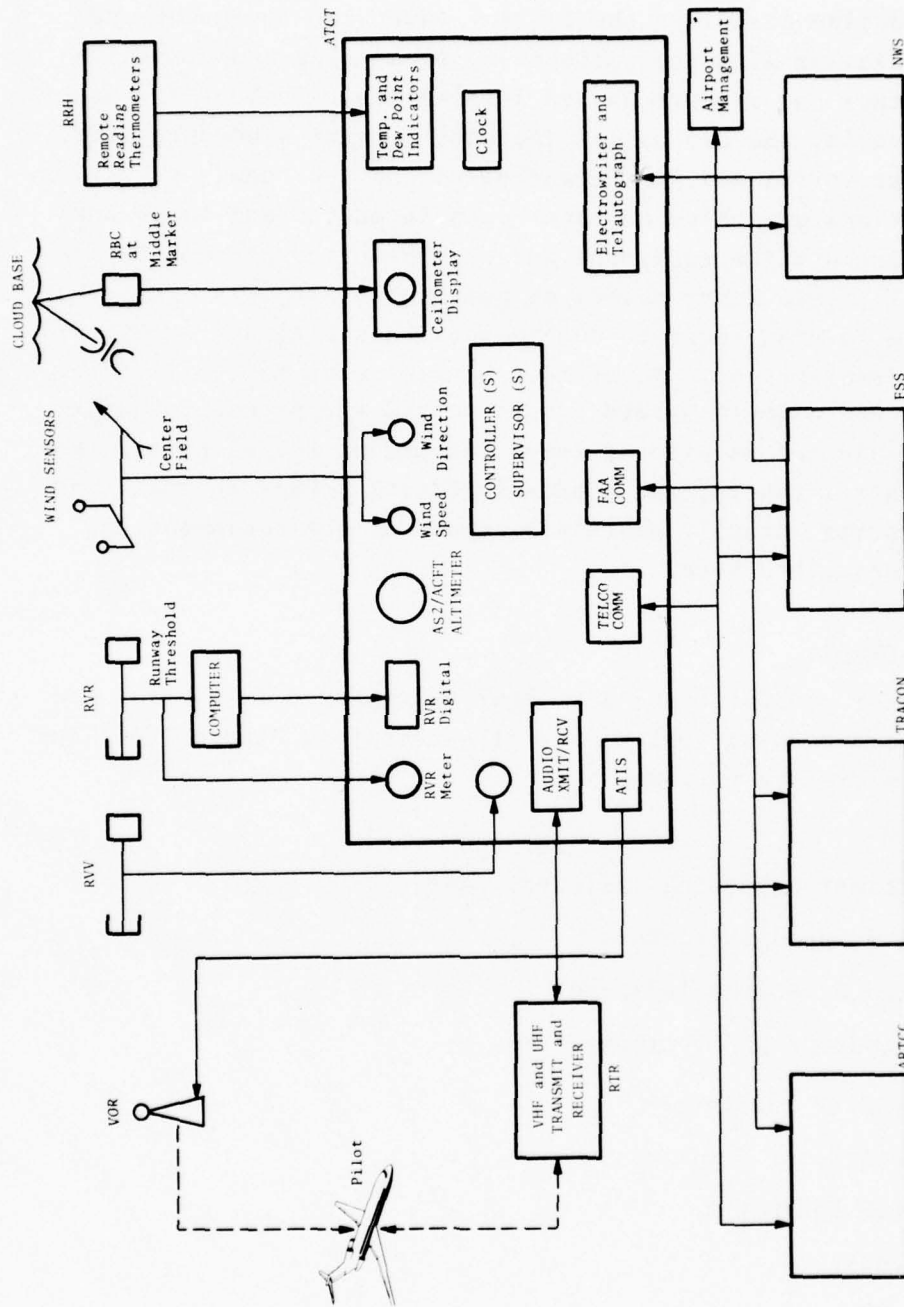

FIGURE 5.6-1. WEATHER AND HAZARD EQUIPMENT FOR AIRPORTS

## Equipment

- i. Field Wind Sensors
- j. RVV Transmissometer
- k. RVR Transmissometer
- l. Remote Transmitter-Receiver (RTR)
- m. Hygro-Thermometer(s)
- n. Ceilometer (e.g., RBC)

## Data Sources

- o. NWS Office (local)
- p. FSS (local)
- q. ARTCC
- r. TRACON

These eighteen items are discussed in subsequent paragraphs. The equipment within the tower is located at different control positions, depending on the individual tower and runway layouts. Tables 5.6-1 through 5.6-4 give the results of an analysis of instrument locations at 22 major towers. The instruments covered are Altimeter Setting Instrument (ASI), Wind Indicators, RVR/RVV Indicators, Ceilometers, Transcription Devices (Telautograph/Electrowrtier), ATIS Equipment. In general, the first three of these instruments are placed at the Ground Control and Local Control positions, and the last three are not; but the placements are not uniform and no general placement rule can be given.

The ASI is a 10-inch diameter, direct reading aneroid barometer. In some towers, a digital altimeter or aircraft altimeter is employed. A mercury barometer is available at some towers or FSS's. Two aneroid devices (ASI, aircraft altimeter, or a combination) are required at a facility not having access to a mercury barometer.

Wind Speed Indicators and Wind Direction Indicators are usually 4-inch or 6-inch diameter repeater indicators mounted in proximity to the ASI or altimeter at the GC and LC positions.

ABBREVIATIONS USED IN TABLES 5.6-1 THROUGH 5.6-4

CONTROLLER POSITIONS

CD - Clearance Delivery  
FD - Flight Data  
GC - Ground Controller  
LC1 - Local Controller #1  
LC2 - Local Controller #2  
LS - Local Sequencer  
TS - Tower Supervisor  
CC - Cab Coordinator  
HC - Helicopter Control

AIRPORTS

BAL - Baltimore	MIA - Miami
CLE - Cleveland	MSY - New Orleans
DCA - Washington/National	PHL - Philadelphia
DEN - Denver	PHX - Phonex
DET - Detroit/City	PIT - Pittsburg
DTW - Detroit/Metro	SNA - Santa Ana/Orange County
HNL - Honolulu	SJU - San Juan
IAH - Houston	TPA - Tampa
JAX - Jacksonville	YIP - Detroit/Willow Run
LAS - Las Vegas	
MCI - Kansas City	

TABLE 5.6-1. LOCATION OF ASI AND WIND INDICATORS  
IN SOME MAJOR TOWERS

AIRPORT	CONTROLLER POSITION							
	FD	CD	GC	LC1	LC2	TS	CC	HC
BAL			✓	✓+				
CLE			✓+	✓+				
DCA			✓	✓+	✓+			
DEN		✓+	(1)	✓+				
DET	✓+		(1)	✓+				
DTW	✓+		✓+	✓+				
HNL			✓+	✓+				
IAH			✓+	✓+	✓+			
JAX			✓+	✓+				
LAS		✓+		✓+				
MCI			✓+	✓+	✓+			
MIA			(1)	✓+	✓+		✓+	
MSY			✓+	✓+				
PHL			✓+	✓+				
HX			DA	✓+	✓+			
PIT	(1)		✓+	✓+				
SNA				✓	✓	0		✓
SJU			✓+			(2)	✓+	
STL			✓+	✓+				
TPA			✓+	✓+		✓+		
YIP		✓+	(1)	✓+				

NOTES

(1) Controller has view of both Wind Speed/Direction and Altimeter Setting instruments located at an adjacent position.

(2) Two sets of instruments.

✓ - Wind Speed and Direction

0 - Altimeter Setting Indicator

✓+ - Altimeter, Wind Speed, and Wind Direction

DA - Digital Altimeter

TABLE 5.6-2. LOCATION OF RVR/RVV AND CEILOMETER INDICATORS IN SOME MAJOR TOWERS

AIRPORT	CONTROLLER POSITIONS							
	FD	CD	GC	LC1	LC2	TS	CC	HC
BAL			✓	✓				
CLE				✓				
DCA				X				
DEN					✓			
DET								
DTW			✓	✓				
HNL			(1) (2)					
IAH			✓					
JAX			✓		(2)			
LAS								
MCI					✓			
MIA				✓	✓			
MSY			✓	✓				
PHL				✓				
PHX				X				
PIT			✓					
SNA			✓	✓			0	
SJU								
STL				✓				
TPA			✓					
YIP					✓		0	

NOTES

(1) Planned.

(2) Dual Installation

LEGEND

- ✓ - RVR at the position
- X - RVV at the position
- ✓ - RVR and RVV at the position
- 0 - Ceilometer

TABLE 5.6-3. LOCATION OF TRANSCRIPTION DEVICES IN SOME MAJOR TOWERS

AIRPORT	CONTROLLER POSITIONS							
	FD	CD	GC	LC1	LC2	TS	CC	HC
BAL								
CLE		E						
DCA								E
DEN						E		
DET	E							
DTW	E(1)							
HNL	E							
IAH	E(2),T							
JAX	E							
LAS								T
MCI								
MIA						T		
MSY		T						
PHL								
PHX				T				
PIT						T		
SNA								
SJU			E					
STL								
TPA			E					
YIP						T		

NOTES

(1) Airport Electrowriter co-located

(2) Dual Installation

LEGEND

E - Electrowriter

T - Telautograph or Telautowriter

TABLE 5.6-4. LOCATION OF ATIS EQUIPMENT AT MAJOR TOWERS  
CONTROLLER POSITION

AIRPORT	FD	CD	GC	LC1	LC2	TS	CC	FC
BAL		√+						
CLE		√+						
DCA								
DEN								
DEN								
DET			√+					
DTW	√+							
HNL		√+						
IAH	√							
JAX	√+							
LAS		√+						
MCI		√+						
MIA		√						
MSY			√+					
PHL	√							
PHX		√+						
PIT						√		
SNA						√		
SJU			√+					
STL		√+						
TPA	√+							
YIP								

LEGEND

- √ - ATIS
- √+ - ATIS with clock at same or adjacent position

The Telautograph and Electrowriter are electromechanically driven pens connected to a repeater pen at a remote location. They usually carry hourly weather information and may be located almost anywhere in the cab.

RVR and RVV are Runway Visual Range and Runway Visibility Value indicators. RVR has replaced RVV at most major airport towers (see Table 5.6-2). The older RVV system is based on a standard intensity projector and photoelectric detector located near the runway. It is calibrated to indicate visibility, which is defined as the distance in statute miles that a human observer can see a 25 candle power source at night or dark objects against the horizon in day. The RVR system employs High Intensity Runway Lights (HIRL) instead of the standard projector and gives a value expressed in hundreds of feet. The HIRL may be set at three levels of illumination, the value of which must be taken into account by the controller in determining the RVR value. The more advanced RVR systems employ digital logic to determine the RVR value from HIRL settings, the photoelectric receivers near the runway end, and a day-night detector.

The Ceilometer Indicator of the Rotating Beam Ceilometer (RBC) is a cathode-ray tube displaying the intensity of light received by a vertically directed detector. The intensity is a function of the angle of the rotating beam as it illuminates the cloud base above the detector. The angle is at maximum intensity converted to cloud base height, or ceiling, given the distance between projector and detector. The dual beam projector rotates 5 times per minute, giving one reading every six seconds. The RBC which is generally placed at the middle marker of the ILS system, was first installed in 1950.

The Automated Terminal Information System (ATIS) comprised of a microphone, a continuous belt recorder, and a playback mechanism, is used to record weather and traffic information for continuous broadcast. Much of the communication load thereby is removed from the controller; the pilot benefits by being able to receive the tower information at his convenience. The ATIS recording is revised whenever new meteorological information is received (usually every hour) or when other significant changes take place.

The most common clock is a digital readout secondary clock slaved to a radio controlled master clock in the tower or TRACON. Clocks read to the nearest minute, giving a maximum error of 30 seconds and a mean error of 15 seconds. Time of day is required in the tower for ATIS recordings, weather observations, SIGMETS, flight strip recording, runway changes, time approaches, and, most importantly, for departure and arrival separation.

The Field Wind Sensors are usually one or more cup anemometers and wind vanes located near the airport surface. By FAA Order 6560.3A, all wind information employed at an airport is derived from wind sensors at a single location on the surface. That location where official wind information is collected, is commonly referred to as center field. Because of the desire to maintain continuity of the meteorological data at a fixed position in the face of airport expansion, the center field location has never been moved and today is substantially removed from the geometric center of the runway areas at many airports. Center field wind readings may differ from winds at the extremes of the several runways.

The Remote Transmit/Receive Station (RTR) is a radio transmission station located on the airfield or in proximity to the airport. It relays voice information on VHF/UHF frequencies between tower controller and pilot, including weather and airport hazard information.

A hygrometer is employed to obtain temperature and dew point at Limited Aviation Weather Reporting Stations (LAWRS) towers, where remote reading instruments are provided.

#### 5.6.2 Procedures <sup>7,8</sup>

This section describes the flow through the preceding equipment of the various types of weather and airport hazard information.

The weather observations employed in the tower originate in one of three ways:

- a. From the NWS Office associated with the tower.
- b. From the FSS associated with the tower.
- c. At the tower itself when it serves as a Limited Aviation Weather Reporting Station.

A tabulation of the inputs and outputs of the major weather system equipments is given in Tables 5.6-5 through 5.6-9.

5.6.2.1 Altimeter Settings - The primary instrument for altimeter settings is the ASI, if one is installed. The aircraft type altimeter is used if there is no ASI or for checking malfunctions of the ASI. The primary and backup instruments are compared once per week with NWS reported altimeter setting and once per day with each other. If there is no backup, the comparison with NWS data is done every day. Daily comparisons are made between 0800 and 0900 LST. Differences of greater than 0.05 inches at non-precision approach locations and 0.02 inches at precision approach locations invalidate the readings. The correction factors for tower altimeters are applied to the normal reading before transmission to pilots.

The controller transmits the altimeter setting over VHF/UHF via the RTR facility. The name of the facility at which the reading was taken, and the time of the reading, are conveyed to the

TABLE 5.6-5. INFORMATION FLOW - ALTIMETER SETTING INDICATOR

INPUTS

From: Airport Ambience  
Form: Mechanical  
Frequency: Continuous  
Content: Atmospheric pressure

From: Controller (see Table 5.6-1)  
Form: Hand Setting  
Frequency: 1/day  
Content: Correction factor for ASI instrument error

OUTPUTS

To: Controller  
Form: Pointer on 9" dial  
Frequency: As required  
Content: Altimeter Setting (MSL pressure in hundredths of inches mercury).

TABLE 5.6-6. INFORMATION FLOW - WIND SPEED/WIND DIRECTION

INPUTS

From: Center Field  
Form: Electrical, analog  
Frequency: Continuous  
Content: Surface wind speed/surface wind direction

OUTPUTS

To: Controller  
Form: 4" or 6" dial calibrated 0-100 knots/4"-6" dial  
calibrated 0°-360°  
Frequency: As required  
Content: Centerfield surface wind speed in knots, direction  
from magnetic north in degrees

TABLE 5.6-7. INFORMATION FLOW - RVR/RVV

INPUTS (RVR)

From: Transmissometer located at touchdown end of instrumented runway, and associated computer  
Form: Electrical, analog  
Frequency: Continuous  
Content: Runway Visibility Range (See Text)

INPUTS (RVV)

From: Field Transmissometer  
Form: Electrical, analog  
Frequency: Continuous  
Content: Runway Visibility Value (See Text)

OUTPUTS (RVR)

To: Controller  
Form: Digital readout  
Frequency: As required  
Content: Runway Visibility Range in hundreds of feet

OUTPUTS (RVV)

To: Controller  
Form: Dial indicator  
Frequency: As required  
Content: Runway Visibility Value in miles and fractions of miles

TABLE 5.6-8. INFORMATION FLOW - ELECTROWRITER/  
TELAUTOGRAPH (NON-LAWRS TOWERS)

INPUTS

From: Nearest NWS Office or FSS  
Form: Electrical, analog  
Frequency: About once/hour, or upon significant change  
Content: See OUTPUTS

OUTPUTS

To: Controller  
Form: Handwritten hard copy  
Frequency: Once/hour or upon significant change  
Content: Observing Station (3-letter identifier)/cloud height (hundreds of feet), cloud type (symbol), type of ceiling observation (1-letter code), ceiling height (hundreds of feet), ceiling type (symbol)/visibility (statute miles and fractions), weather type and obstructions to vision (character string)/sea level pressure (tenths of millibars, less first 2 digits)/temperature (degrees Fahrenheit)/dew point (degrees Fahrenheit)/wind direction (tens of degrees from true north), wind speed (knots), gust or squall character (G or Q), peak wind speed in gust or squall (knots), wind shift characters (WSHFT), time of wind shift (local hours and minutes)/altimeter setting (hundredths of inches mercury, less the first character)/Runway visibility character (R) followed by: identifier of runway of measurement, type of measurement (VR if RVR, VV if RVV), runway visibility (hundreds of feet if

TABLE 5.6-8. INFORMATION FLOW - ELECTROWRITER/  
TELAUTOGRAPH (NON-LAWRS TOWERS) (Continued)

OUTPUTS

Content:  
(Cont'd)

RVR, statute miles and fractions thereof if RVV, variability character (V), runway visibility upper limit (hundreds of feet if RVR, statute miles and fractions thereof if RVV)/Pilot reports of cloud bases or tops (MSL feet in hundreds) preceded by cloud cover symbol if tops, followed by cloud cover symbol if base

TABLE 5.6-9. INFORMATION FLOW - ATIS

INPUTS

From: Controller

Form: Voice

Frequency: When revised weather observation is received or upon change in other recorded data (about 1/hr)

Content:

1. Airport identification
2. Sky condition below 10,000 feet; visibility if less than 7 miles, obstructions to vision, wind direction (magnetic), wind speed (knots), other weather remarks
3. Temperature (optional)
4. Altimeter setting (optional)
5. Instrument approach in use, or vector to be provided
6. Landing runway(s)
7. Takeoff runway(s)
8. NOTAMS and Airman's Advisories
9. 'Check Density Altitude' message if temperature is 85°F or more and tower altitude 2000 feet or more
10. Other pertinent information
11. Phonetic alphabet code of the message, and instructions to pilot to acknowledge receipt by informing controller on initial contact

TABLE 5.6-9. INFORMATION FLOW - ATIS (Continued)

OUTPUTS

To: Pilot

Form: Voice transmission on TVOR/VOR/VORTAC or on specific  
V/UHF tower frequencies (occasionally on LF)

Frequency: Continuous

Content: See INPUTS

pilot as well as the setting value. The setting associated with a compulsory reporting point is issued when the pilot reports over that point, or when observed over the point on radar, if the aircraft is below FL180. Altimeter settings may also be given upon pilot request or when the controller judges it necessary. Generally, if a setting has been transmitted to the pilot before departure, another setting is not issued while he is within 50 miles of the tower. The pilot may request a setting in millibars, which the controller must obtain directly from the nearest weather reporting station (NWS or FSS) rather than from the transcribed weather report. A pilot request for altimeter setting at any station within 50 miles of the tower is honored by the tower.

Altimeter settings are also part of ATIS transmissions. If ATIS has not been received by a landing aircraft, the controller issues landing information, which includes altimeter setting. The altimeter setting is also employed to determine the lowest usable flight level at or above FL 180, as follows:

<u>Altimeter Setting</u>	<u>Lowest Usable FL</u>
29.92 or higher	180
29.91 to 28.92	190
28.91 to 27.92	200

Finally, the altimeter setting is part of the "current weather" information and the LAWRS observations (see Section 5.6.2.4).

5.6.2.2. Wind Speed and Direction Readings - The center field wind sensor readings are compared at the beginning of each working day with the readings obtained from the same sensors by the NWS or a military weather station, if any. This requires accurate information on magnetic variation (since NWS wind is reference to true north) and time of observation. A discrepancy of five degrees or five knots calls for maintenance, and a discrepancy of over 10 degrees or 10 knots renders the equipment inoperative. The backup wind sensors are either redundant

units at center field, or readouts at the FAA, NWS or military weather facility.

The tower provides wind information to the associated TRACON or RAPCON, if it is remotely located, by telautograph, teletypewriter, voice lines or any other convenient means.

An approach control tower (TRACAB or non-radar approach control tower) must furnish surface wind information to an arriving aircraft if the pilot has not acknowledged receipt of the latest ATIS containing it.

Wind information is part of the general weather information disseminated from the tower and is also employed in runway selection.

5.6.2.3. RVR and RVV Readings and Reporting - Proper functioning of RVR equipment is checked by periodic maintenance procedures (FAA order 6560.8). FAA maintenance personnel are responsible for determining whether the field sensor is malfunctioning; ATC personnel are responsible for reporting any apparently malfunctioning display units. If all units for the runway in use are not available, the weather observing facility (NWS, FAA) is requested to provide RVR and/or RVV to the tower.

RVR meter indications are based on High Intensity Runway Lights (HIRL) setting 5. A table must be used to convert the readings made with HIRL settings 3 and 4. RVR digital readouts do not cover all values in the CAT III range.

Procedures require issuing RVR or RVV for the runway(s) in use to both departing and arriving aircraft when prevailing visibility or RVV is 1-1/2 miles or less and when RVR is 6000 feet or less. Usually, RVR is conveyed to departing aircraft from the tower. Mid runway and rollout RVR is issued when it is less than 2000 feet, and also less than the touchdown RVR. Finally, RVR or RVV are issued when they are less than the minima for the particular approach being executed.

5.6.2.4. Weather Information Reporting (General) - An "official weather" report originates in the tower's associated NWS Office, FSS, or in the tower itself if it is a LAWRS unit and has no access to the other two sources. It usually contains:

Location Identifier of Observing Facility

Sky and Ceiling Conditions

Visibility and Obstructions to Vision

Sea Level Pressure

Temperature and Dew Point

Wind Speed and Direction

Altimeter Setting

Runway Visual Range

Pilot Reports

A detailed listing is given in Table 5.6 -8 of the type of report received at the tower from a NWS Office via telautograph. This information is transmitted, in whole or in part, to departing, arriving, and over-flying aircraft both IFR and VFR via VHF/UHF communications. In most large towers an hourly ATIS report is prepared, containing this weather information among other items. If the tower is a LAWRS, the procedures specify that the following information be included.

- a. Base of clouds - as determined by a ceiling measuring device, pilot report, or estimate
- b. Sky condition
- c. Prevailing visibility
- d. Weather
- e. Obstruction to vision
- f. Surface wind
- g. Temperature and dew point where remote reading instruments are available

- h. Altimeter Setting
- i. Remarks
- j. RVV or RVR, where available

Controllers are required when coming on duty to become familiar with the pertinent weather information and to stay aware of current weather needed for their duties. They must forward weather updates to the appropriate control facility (ARTCC, TRACON) when the official weather changes: to below 1000-foot ceiling, to below the highest circling minimum, or less than 3 miles visibility, or when it improves beyond those conditions, and when it undergoes changes classified as special weather observations while under the above conditions. Procedures also require that non-approach control towers issue the official weather to aircraft executing an instrument approach if the weather is different from that of the ATIS or different from that previously forwarded to the ARTCC or TRACON.

At approach control towers, the ATIS report usually provides the latest weather for IFR flights. If, however, the pilot has not received the latest ATIS information, the tower must provide IFR arrivals with:

1. Surface wind
2. Altimeter setting
3. Ceiling and visibility, if the ceiling at intended landing airport is below 1000 feet (or the highest circling minimum, whichever is greater) or if the visibility is less than 3 miles.
4. Any special weather observations, if time permits.

The altimeter setting is issued whether or not contained in the recent ATIS, and additional IFR services include general weather information and instrument readings. Specific values such as ceiling and visibility, however, may be conveyed only if the tower controller involved is properly certified and acting as official observer for the elements involved, or has obtained the information from an official observer or weather station.

5.6.2.5. Pilot Reports (PIREPS)<sup>9</sup> - PIREPS received by tower controllers are relayed to other towers to the ARTCC, FSS, WSO, Weather Service Forecast Office (WSFO), and to military units, as well as to the team supervisor, area supervisor, or assistant chief. The team supervisor is responsible for dissemination of PIREPS to other controllers and to the local ARTCC flow controller. Cloud base and top information is reported by pilots relative to MSL. PIREPS of base and tops are incorporated into official weather as shown in Table 5.6-8. Terminal facilities chiefs must establish procedures to insure that cloud base and top reports are obtained on a regular 2-hour basis when ceiling is 5000 feet or less.

5.6.2.6. Significant Meteorological Information (SIGMET) and Notice to Airmen (NOTAM) - A SIGMET alert is broadcast once on all frequencies. NOTAMS usually deal with facility outages but may also deal with runway outages due to weather conditions. Both may be included in ATIS messages, if relevant, or in official weather reports.

5.6.2.7. Airport and Runway Conditions - A controller observing or being informed of any landing area hazard must copy, confirm, and relay the information to the airport manager. Only the airport management may legally close a runway, but the controller may withhold departure, landing, or touch-and-go clearance to a closed or unsafe runway. Operations under such conditions are at the pilot's own risk.

Tower controllers must issue timely information, such as the existence of construction work, rough pavement, ice, snow, slush, or water on the active runway(s), and lighting system abnormalities.

Braking action information as obtained from pilots or aircraft management is to be described as "good," "Fair," or "poor" and the type of aircraft from which it was obtained is to be included in reports to pilots. Runway Condition Readings (RCR), if available, are transmitted to non-military pilots only upon request.

Takeoff clearance cannot be issued to commercial flights (except training, test, or ferry flights) when prevailing visibility is less than 1/4 mile, RVV is less than 1/4 mile, RVR (analog) is less than 2000 feet, or RVR (digital) is less than 1600 feet.

5.6.2.8. Runway Selection - Most major airports have a runway selection scheme designed to reduce the effect of aircraft noise within the limitations imposed by the runway layout, instrumentation, and prevailing wind. If no such program is in operation, the controller must select the runway that is most closely aligned with the prevailing wind. If the wind is less than five knots he must employ the "calm-wind" runway. The choice may also be influenced by pilot request or some operational advantage (e.g., higher acceptance rate).

If the runway selection or use program results in a tail wind, the wind velocity and direction taken from the center field measurements must be stated to the pilot. The center field wind measurements are employed here.

5.6.2.9. Wake Turbulence Procedures<sup>10</sup> - While no equipment is deployed in the present system for wake turbulence information, procedures are not lacking. The present procedures provide the following definitions for small, large, and heavy aircraft:

Small: 12,500 pounds or less maximum certified takeoff weight

Large: greater than 12,500 pounds but less than 300,000 pounds maximum certified takeoff weight

Heavy: 300,000 pounds or more maximum certified takeoff weight

Some aircraft types (B707, Ilyushin, DC-8) have both large and heavy versions. Flight strip data are inadequate to distinguish between large and heavy versions, so that the controller must, in many cases, rely upon the common airline practice of identifying the aircraft size by the word "heavy" following initial radio contact with tower. Controllers must themselves use such terminology in radio communications.

For two aircraft landing successively under radar control in the terminal area, the required separations will have been applied by en route and approach control before hand-off to the tower (4 miles for small behind large, 5 miles for large behind heavy, 6 miles for small behind heavy).

At non-radar approach control facilities the following separations must be maintained by the controller:

a. IFR aircraft of any size landing behind an arriving heavy jet must be separated from it by two minutes if they are using the same runway, crossing runways, or parallel runways less than 2500 feet apart; except that a small aircraft arriving on the same runway as a heavy must be separated from it by three minutes.

b. IFR or VFR aircraft landing on a runway that crosses the airborne portion of the path of a heavy jet departing a crossing runway must have a two-minute separation from the intersection point.

c. IFR or VFR aircraft of any size must have a two-minute separation behind a heavy jet departing the same runway, a parallel runway separated by less than 2500 feet, a crossing runway if the projected flight paths will cross,\* or a parallel runway separated by 2500 feet or more when the projected flight paths will cross. Successive departures on independent parallels without crossing flight paths have no separation requirements.

In addition to providing positive separation, approach control and non-approach control towers are required to advise the pilot of wake turbulence in the following circumstances: 1) aircraft of any size landing behind a heavy jet that is departing the same or a parallel runway less than 2500 feet away; 2) aircraft of any size landing on a runway that crosses behind the rotation point of a heavy jet departing a crossing runway; 3) VFR aircraft whose arrival flight path will cross that of a heavy jet arriving on a crossing runway.

---

\* If the aircraft ground paths cross (intersection takeoff) the separation is three minutes.

Although the non-radar wake turbulence separations are specified as one-, two-, or three-minute intervals the standard tower equipment does not include an interval timer. The standard digital readout secondary clock is precise to the nearest minute. (See Section 5.6.1.) If the controller allows two clock changes to elapse for a two-minute separation the average separation error will be -30 second, or -25 percent. If he allows three clock changes, the average separation error will be +30 seconds or +25 percent.

## 5.7 INSTRUMENT LANDING SYSTEM (ILS)

### 5.7.1 Principles of Operation

The Instrument Landing System (ILS) currently in use operates in the VHF and UHF radio frequency bands. The first commercial system was demonstrated in 1939. The ILS was adopted for national service in 1941 and by ICAO as the international standard in 1945

The ILS may be divided functionally into three parts:

- Guidance Information - localizer, glide slope
- Range Information - marker beams
- Visual Information - lights

The guidance components of the ILS are the localizer and the glideslope. The localizer provides guidance in the horizontal plane to aircraft approaching and landing. It operates by radiating two different VHF signals at the same carrier frequency. One of them is amplitude modulated at 90 Hz and is radiated in a pattern that predominates on the left side of the course line (runway center line, extended) as seen from the approaching aircraft. The other VHF signal is amplitude modulated at 150 Hz and is radiated in a pattern symmetric to the first and predominant on the right side of the course line. Along the course line the two radiated signals are of equal strength. The glideslope station provides guidance in the vertical plane. Two amplitude-modulated UHF signals are radiated; the first modulated at 150 Hz predominates below the descent path angle and the second modulated at 90 Hz predominates above it. Along the indicated line of descent the signals are equal.

The marker beacons, placed along the extension of the runway center line, operate by radiating 75 MHz signals upward in a fan pattern. These signals provide range information to overflying aircraft. Ordinarily, there are two marker beacons associated with an ILS, the outer marker and the middle marker. At some locations a third, or inner marker, is also used. The outer marker is some five miles from the end of the runway whereas the

middle marker indicated a position at which the aircraft is approximately 3500 feet from the landing threshold. The inner marker, where installed, will indicate a point at which an aircraft is at a designated decision height (DH) on the glide path between the middle marker and the landing threshold.

Visual reference is provided by approach and runway lights and, at some locations, by touchdown and centerline lights.

System status information is displayed in the tower cab from where the system is controlled.

#### 5.7.2 Categories of Operation

Several categories of ILS operational capability have been established and defined by minimum decision heights (DH) and/or minimum runway visual ranges (RVR).

<u>Category</u>	<u>Decesion Height</u>	<u>Runway Visual Range</u>
I	200 feet	2400 feet
II	100 feet	1200 feet
IIIa	0 feet	700 feet
IIIb	0 feet	150 feet
IIIc	0 feet	0 feet

As of March 31, 1977, there were 536 commissioned full ILS systems in operation, 493 of which were Category I, 39 Category II and 4 Category IIIa.

A full Category I ILS ground system consists of a localizer glide slope, outer and middle marker beacons, possibly an RVR and ceilometer, and a Medium-intensity Approach Light System with runway alignment indicator lights (MALSR) with sequenced, flashing lights. (RVR's and ceilometers are not usually included in the "standard" ILS installation; however, they frequently appear at busy sites.)

Upgrading a full Category I ILS installation to Category II requires:

- a. Assuring the localizer and glide slope performs within specified tolerances. In order to achieve the required

improvement on localizer performance, an antenna suitable for providing improved localizer performance will be required. Capture effect glide slope or sideband reference glide slope may be required and, in addition, some site preparation needed for necessary glide slope path and course improvements. In many cases it also is necessary to relocate the glide slope to meet threshold crossing height requirements;

- b. Installation of an inner marker beacon;
- c. Retrofitting existing approach light system to Category II standards (This is not a requirement if an ALSF-1 is available and meets the gradient standards);
- d. Installation of touchdown zone and centerline lighting systems;
- e. Installation of hold signs and critical area markings;
- f. Installation of a second RVR (A third RVR is required for runways longer than 8,000 feet);
- g. Installation of dual equipment for localizer and glide slope components.

Upgrading a Category II ILS installation to a Category IIIa installation requires:

- 1. Assuring performance within tolerances as in (a) above but more stringent Category IIIa tolerances
- 2. Installation of a third RVR
- 3. Upgrading the approach light system to ALSF-2
- 4. Providing redundant operation of localizer and glide slope components

### 5.7.3 Use of ILS

When the aircraft using the ILS has been cleared to land by the airport controller and has performed the initial approach procedure, it will be about 6 to 8 miles from the runway at an altitude of 1000 to 1500 feet above the terrain. The aircraft

receiver picked up the localizer signal some time previously and actuated a cross pointer instrument in the cockpit, instructing the pilot to fly left or right so as to intercept the localizer centerline. The aircraft, when it is on this course, is usually in level flight.

Approximately five miles from the runway threshold the aircraft passes through the fan beam of the outer marker, which actuates a flashing purple light on the instrument panel and a tone in the pilot's radio headphones. The pilot is alerted to intercept the glide slope. At the outer marker the aircraft is approximately 1200 feet above the terrain. It follows the glide slope path at a nominal descent angle of 2.5 -3 degrees.

Approximately 3500 feet from the threshold, the aircraft intercepts the fan beam of the middle marker at an altitude of about 200 feet. At this point, for a Category I system, the glideslope signal becomes erratic, therefore, the pilot must be able to see the runway or approach lights, and land using normal visual control, or execute a missed approach procedure. For higher categories of operation, signal integrity is maintained to the appropriate DH level.

#### 5.7.4 Limitations of the System

At the frequencies used by ILS, radio signals are reflected and beam patterns are distorted by large objects on the ground, such as buildings (particularly metal hangars) and aircraft on the runways. ILS facilities require that the ground plane be 1000 feet wide and that no building be within 750 feet of the runway centerline. The ground controller must keep aircraft on the surface away from those locations in which their presence distorts the radiated patterns.

The glide slope pattern in particular is affected by the terrain surface, since the terrain acts as a ground plane that affects the beam shape. Extensive grading work is frequently necessary to prepare the terrain before an ILS system is installed. Flooding caused by bad weather, for instance, may compromise the

system by distorting the beam. Furthermore, there are locations in which ILS can not be installed at all because of terrain effects, e.g., over the ocean where the effective level of the ground plane changes with the tide.

There are only 20 ILS frequency channels available, which requires in some cases that the range of some systems be reduced (to typically 18 miles) to avoid interference with other systems. In other cases, the same channel must be used on opposite ends of a given runway, adjacent runways must share the same channel or coordinated channel changes must be made at airports in congested areas.

The region in which the lateral guidance signal is proportional to the aircraft deviation from the course line is quite narrow (some 2 1/2 degrees). The effect is that aircraft intersecting the course line at reasonably large angles tend to overshoot it and require some distance to achieve alignment with the course line. Therefore, aircraft have to align themselves with runway approximately 6 miles or more from the threshold and approach the runway along the same straight path. Thus the use of ILS is incompatible with curved approaches and steep approaches by VSTOL aircraft.

## REFERENCES FOR SECTION 5

1. "Terminal Flight Data Entry and Printout Equipment," FAA Academy, FAA Aeronautical Center, Oklahoma City, OK, Air Traffic Training Publication N-3, September 1974.
2. "NAS Configuration Management Document" (Remote Outputs), NAS-MD-315, Revised July 1976.
3. Hierbaum Jr., Felix F. et al.; "The 1974 National Seminar On Terminal Information Processing System (TIPS)," November 12, through 14, 1974; U.S. Dept. of Transportation, Federal Aviation Administration, NAFEC: Atlantic City, NJ, 08405, March 1975.
4. "TPX-42 A Numeric Beacon Decoder," FAA Academy, Oklahoma City, Oklahoma, TM-72-0-2 October 1971.
5. "Specification for Automated Radar Terminal Air Traffic Control System (ARTS II)" FAA, Washington, D.C., FAA-E-2570, 24 August 1973.
6. "NAS Operational Equipment ARTS III" FAA Academy, Oklahoma City, Oklahoma, Air Traffic Training Publication N-9, March 1973.
7. U.S. Dept. of Transportation, Federal Aviation Administration, "Air Traffic Control," FAA Order 7110.65, 1 January 1976, and amendments thereto.
8. "Airman's Information Manual," Federal Aviation Administration, U.S. Dept. of Transportation, Part I, Nov. 1976.
9. "PIREPS" of Cloud Base-Top Information," section 1315 of Facility Management Handbook, Order 7210.3C, Federal Aviation Administration, U.S. Dept. of Transportation.
10. "Definition of Wake Turbulence." Federal Aviation Administration, U.S. Dept. of Transportation, Advisory Circular 90-23D.

## BIBLIOGRAPHY FOR SECTION 5

"Aircraft Accident Report, North Central Airlines, Inc., McDonnell Douglas DC-9-31, N954N, and Delta Air lines, Inc., Convair CV-880, N8807E, O'Hare International Airport, Chicago, Illinois, December 20, 1972," National Transportation Safety Board, Washington, DC, Rep. No. NTSB-AAR-73-15, July 1973.

"Airman's Information Manual," U.S. Dept. of Transportation, Federal Aviation Administration, U.S. Government Printing Office Washington DC, Part I, November 1976.

"Airport Surface Traffic Control Systems Deployment Analysis," G. Baran, R.A. Bales, J.F. Koetsch, U.S. Department of Transportation, Federal Aviation Administration, FAA-RD-74-6, January 1974.

"ARTS III BRITE A/N Equipment, Preliminary Instruction Book Volume I, T16310.9, 2/20/69. Texas Instruments, Inc. DOT FA69WA-2071 Dallas, Texas.

"Bright Radar Indicator Tower Equipment, Preliminary Instruction Book," Volume I, FAA, ITT Corp., Fort Wayne, IN, DOT FA 69WA-2209 T16410.3, 6/30/69.

"Definition of Wake Turbulence," U.S. Dept. of Transportation, Federal Aviation Administration, Advisory Circular 90-23D, Washington, DC.

"Design Data for ASDE-2 NU-BRITE Display System, ITT Aerospace/Optical Division, Fort Wayne, IN, DOT-TSC-991, 4/3/75.

"Establishment Criteria for ASDE-3," Federal Aviation Administration, Office of Aviation System Plans, Rep. No. ASP-75-3, December 1975. M. Olson.

"NAS Operational Performance Analysis Report," FAA Air Traffic Service, August 1976.

"Terminal Facility Configuration and Data Survey Boston Tower/TRACON," FAA-NA-75-170, 7/75, NAFEC, Atlantic City, NJ.

"Terminal Information Processing System Briefing Vugraphs, Working Paper 11111, Mitre Corporation, Bedford, MA July 9, 1975.

AD-A048 306

TRANSPORTATION SYSTEMS CENTER CAMBRIDGE MASS  
CHARACTERIZATION OF CURRENT TOWER CAB ENVIRONMENTS. (U)  
NOV 77 V J HOBBS, D F CLAPP, P REMPFER  
TSC-FAA-77-19

F/G 13/3

UNCLASSIFIED

FAA-EM-77-10

NL

3 OF 3  
ADI  
A048306



END  
DATE  
FILMED  
2-78  
DDC

## APPENDIX A. TECHNICAL DETAILS OF CERTAIN TOWER EQUIPMENT

### A.1 PLAN POSITION INDICATOR (PPI)

The earliest and simplest ATC processor/display systems present to the controller a view of the surrounding airspace on a Plan Position Indicator (PPI), a circular CRT which is swept by the electron gun from its center to the edge. The origin of the strobos, corresponding to the location of the radar, is nominally at the center of the scope, while the distance from the center to the edge of the scope corresponds to the maximum useable range of the radar. As the strobe rotates, in synchronism with the rotation of the antenna, a dot is painted for each primary radar return at a distance proportional to the range of the target from the radar. At the same time, the returns from the beacon, or secondary, radar are displayed as slashes (whose relative width corresponds to the 3 degree beam width of the secondary antenna compared to 1-3/4 degree for the primary).

### A.2 BRIGHT RADAR INDICATOR TOWER EQUIPMENT (BRITE)

A number of BRITE systems have been developed, starting with the BRITE-1 and continuing through the BRITE-2 and BRITE-4. In addition, a system, called ASDE BRITE, was developed from the BRITE-2 for use with ASDE; this has since been improved to produce the NU-BRITE system. The BRITE-1 systems are obsolete and practically out-of-service. Since the differences between BRITE-2 and BRITE-4 are slight, only the last-named will be described here, followed by descriptions of the ASDE BRITE and NU-BRITE systems.

A.2.1 BRITE-4 - The BRITE-4 is an analog scan conversion system consisting of a 5-inch diameter CRT PPI with mechanically rotating yoke, associated vacuum tube circuitry, a long-persistence vidicon camera, and a 16-inch diameter CRT TV raster display. The vidicon is optically coupled through a lens to the 5-inch PPI, providing rho-theta to TV raster scan conversion. The bandwidth of the scan conversion system is about 20 MHz.

The display can be remoted by coax and multiwire cable up to 6,000 feet.

The PPI on which the basic presentation is made is 5 inches in diameter with a sweep rate corresponding to that of the local ASR site (approximately 15 RPM). It will operate on five discrete ranges of 6, 10, 20, 30, and 60 miles selectable from the remote control head. Each range will display calibrated range marks: 2-mile marks on the 6- and 10-mile range, 5-mile marks on the 20- and 30-mile ranges, and 10-mile marks on the 60-mile range. The sweep can be de-centered by twice the selected range, except that 60 miles is the sweep range limit.

In addition to range marks, the unit can be furnished with a video mapper. This permits the drawing of a map of the airport and primary air routes to the various runways to aid in tracking targets and monitoring approaches. The mapper is a separate unit not described here.

The TV display is 18.5 inches wide by 18.5 inches high by 27 inches deep and weighs 100 pounds. The display uses 945 lines with a video bandwidth of 30 Hz to 20 MHz. The TV tube is 16 inches in diameter and when mounted in the display exhibits 14-1/2 inches of useable diameter. It is covered with a laminated safety plate and a neutral density filter bonded to the face plate. Contrast and brightness controls are available on the display but can also be remotely controlled. The display may be mounted overhead (hung from the cab ceiling) or in the controller console.

The remote control head is designed to be operated either on a desk top or from a recess in a control console. The head is shown in Figure 5.1-3. The unit measures 12.75 inches deep by 7.625 inches wide by 3.25 inches high and weighs 19 pounds. The panel is illuminated (back light) for night use. The unit permits the independent brightness control of the video map (if present), the range marks, the beacon target return, and the primary target return. In addition, overall brightness and contrast can be remotely controlled (rather than at the display). Also controlled

from this panel are range and decentering (East-West and North-South).

A.2.2 ASDE BRITE - The ASDE-2 BRITE display measures 18.5 inches wide by 18.5 inches high by 27 inches deep and weighs 100 pounds. It uses a 16-inch diameter Cathode Ray Tube (CRT) of which 14-1/2 inches is useable (i.e., shows when installed in the display). Available to the controller on the display are power on/off switch, brightness, and contrast controls. Provisions are made for mounting the display in a yoke and hanging it from the ceiling (as at New York JFK and Boston Logan) or console mounting the display (as at Chicago O'Hare and San Francisco).

The controls for the ASDE-2 presentation are located in a remote (from the display) control head. The control head measures approximately 13 inches wide by 8 inches high by 3 inches deep and weighs 20 pounds. Available to the controller is:

- a. A discrete set of 5 range scales at 5,600 feet, 6,600 feet, 8,600 feet, 10,000 feet, and 18,000 feet (full scale).
- b. East-West and North-South decentering with continuous adjustment up to the range scale selected. For example, at the range scale of 5,600 feet, maximum decenter to the North is 5,600 feet.
- c. An erase function so that when the display becomes smeared by the vidicon storage acting on a range or offset change, the vidicon can be saturated by a small flood light and come up without any smear.
- d. Brightness and contrast which override the display mounted controls for use if the display cannot be reached conveniently.

There is a control head for each independent ASDE channel in the cab. Two bright displays can be driven by each independent channel.

A.2.3 NU-BRITE - Physically the NU-BRITE is similar in basic design to the ASDE BRITE system. Both are analog scan conversion systems optically coupling a vidicon to a 5-inch diameter PPI, providing a raster scan output to a 16-inch diameter (14.5 inch usable) CRT TV display (see Figure 5.2-8). The most significant difference is the increased bandwidth in the PPI, vidicon and TV from 20 MHz to 35 MHz, achieved by broadbanding the video amplifier path and improving coupling to the CRT TV socket. Solid state circuitry is used throughout, including the sweep rotation previously done by the mechanically rotating yoke in the ASDE BRITE.

Minimal loss of display resolution is assured by matching each component performance. PPI spot size is less than 0.003 inch; PPI resolution at 6000 feet is less than 30 feet in range and 0.44 degrees azimuth. The f/1.8 vidicon camera lens is used at reduced aperture to maintain depth of field. Optical resolution capability exceeds overall system resolution. Vidicon minimum resolution is 700 TV lines, and the useable lines on the TV display are 793 (1225 x .93 active vertical scan line x .7 Kell factor). Viewing in high ambient light levels (1000 foot-candles) is made possible by use of a spectral bandpass filterface plate bonded to the TV CRT which attenuates ambient light by 95 percent. Old display data is erased when range scale or offset is changed by a controlled light source at the vidicon surface. Display recovery time following erase is four seconds.

Display persistence (hence target trails) remains a function of the vidicon decay characteristics. Improved resolution is offered by the increased horizontal line count (1225 compared to 945) and by the greater horizontal write speed made possible by the bandwidth increase. Field measurements indicate that system resolution through the display, including operator activity, is improved by 2 to 1 over the ASDE BRITE.

Reliability and adjustment ease are improved by the use of solid state electronics, the elimination of the mechanically rotating yoke, and the replacement of the alternator/cam system by a 10-bit optical encoder for azimuth data generation.

The NU-BRITE control head has similar size (12.75 inches wide by 7.62 inches high by 3.25 inches deep) and weight characteristics as the ASDE BRITE control head. It too provides brightness, contrast, and an erase function, but it differs in its range and offset controls. Range selection is continuous, rather than discrete, and minimum range is 3000 feet. This will permit optimum range selection to include only areas of interest on the display thereby obtaining the best target size and resolution. The minimum range will permit ground control (where he has his own display) to set up on the taxiway hub to improve target detection. Offset is continuous (as with the ASDE BRITE) but is independent of the range selected. Maximum offset is 9000 feet on any range selected. Independent range and offset is important to make use of the minimum range selection especially at remotely located ASDE antenna installations.

### A.3 BRITE ALPHANUMERIC EQUIPMENT

The purposes of the BRITE alphanumeric equipment are (1) to accept BRITE TV video, (2) to interface with ARTS III to receive alphanumeric data for the appropriate targets, (3) to transmit required information to ARTS III for formatting the data, (4) to convert the alphanumeric data to TV video format, (5) to mix the alphanumeric TV video and BRITE TV video, and (6) to transmit the mixed video to the BRITE display. The equipment is composed of an ARTS III interface, a 5-inch diameter CRT for alphanumeric display, a TV camera with a low memory commercial vidicon synchronized with the BRITE camera for conversion to TV video, a video mixer, and several data entry devices.

The data entry devices are an alphanumeric display control panel with the BRITE remote control head, a keyboard, and a position entry module (PEM).

The common BRITE and A/N control panel measures 12.25 inches wide by approximately 14 inches deep by 3.25 inches high and is back lighted for night use. A photo is shown in Figure 5.1-6. The unit has 5 toggle switches to permit selection of alphanumeric data from any of 5 presentations (i.e., take a "quick-look" at

another controller's target data). This would include a presentation displaying data blocks on all beacon equipped targets. The unit has 6 field inhibit toggle switches permitting the controller to blank any or all fields within the data block (e.g., blank all fields such as ground speed leaving only flight identity). Also included is an alphanumeric video gain potentiometer an eight-position rotary switch for selecting the length of the leader to the data block and a three position rotary switch for selecting the size of the alphanumeric to be displayed. The size selected at most major airports is approximately 0.25 inches in height.

The keyboard assembly is an array of keyboard switches mounted in a console measuring approximately 8 inches wide by 8 inches deep by 2.5 inches high in the front, 3.5 inches high in the back. In using the keyboard the controller can enter numerals 0 through 9, the 26 capital letters of the alphabet (set in alphabetical order) and five special symbols. In addition, several function keys are provided (e.g., to drop a track/data block, to initiate or accept handoff, to display track file in preview area, to relocate the preview area, etc.)

The PEM is a small unit measuring approximately 2 inches wide by 3 inches deep by 2.5 inches high and is attached to the keyboard. The unit contains a small joy stick and an enter button. The joy stick is used to slew a cursor to a point on the display (e.g., for locating the preview area, for locating targets for which information is requested or entered). Its use is similar to the track ball in the ARTS III TRACON consoles.

#### A.4 ASDE-2

The ASDE-2 is a high-resolution, conventional fixed-frequency radar using vacuum tube technology (1950's) which operates at 24 GHz and whose antenna rotates at 60 rpm. Table A-1 is a tabulation of ASDE-2 characteristics.

The major subsystems are:

TABLE A-1. ASDE-2 CHARACTERISTICS

Component	General Characteristic
<u>Transmitter</u>	
Frequency	23,800 to 24,270 MHz ( 1.25 cm band)
Pulse width	20 nanoseconds
PRF	14.4 kHz
Peak Power	36 to 50 kW
<u>Receiver</u>	
Noise Figure	19 dB ( maximum)
Bandwidth	IF 100 MHz; Video 50 MHz
Features	AFC local osc., STC, FTC
<u>Antenna/Pedestal</u>	
Reflector Size	12 by 4 feet
Gain	45 dB
Horizontal Beamwidth	0.25 degree at 3 dB point
Vertical Beamwidth	1° to 3 dB points. cosecant squared -1° to -5°, linear
Tilt	From -5° to -20°. Tilt $\pm$ 3°
Polarization	Linear or circular
Scan	60 rpm
<u>Radome</u>	Spherical 1) Inflatable, 2) Geodesic Space Frame ( Logan, O'Hare), 3) Foam ( Andrews)
<u>Rooftop Equipment Weight</u>	Approx. 2500 pounds
<u>Display System</u>	
TV	945 line, 16-in. dia., 14.5 -in. usable viewing surface diameter
PPI	5-in. mechanical yoke
Vidicon	Optically coupled to PPI, 945 line
System Bandwidth	20 MHz

a. Transmitter/Receiver - The dual-channel design provides redundancy. The transmitter consists of a 24 GHz magnetron outputting a 20-nanosecond pulse of 50 kilowatts peak power maximum.

The receiver is a single conversion balanced mixer design with an intermediate frequency bandwidth of 100 MHz. Sensitivity Time Control (STC) is used to provide a target of constant received signal strength regardless of range. A fast time constant (FTC), or differentiator, is available to improve display resolution of a small target following a large target in range. Lacking the sophistication of either constant false alarm adaptive thresholding or adaptive gain control, the ASDE-2 cannot guarantee a clutter-free display under all precipitation conditions.

b. Antenna/Radome - The antenna is a horn-fed parabolic reflector with pencil beam azimuth and cosecant squared elevation patterns. The feed includes a polarizer that is manually positioned to produce linear or circular polarization.

In the original design, the antenna/pedestal assembly was protected from the weather by a spherical air-inflatable radome made of rubberized fabric. Geodesic space frame radomes were installed subsequently at O'Hare, Logan, and Andrews to provide improved rain shedding characteristics and prolonged exterior coating life.

c. Display - The scan-converted display system has already been described (See A.2.2).

There are various aspects of system performance:

1. Resolution - The specified radar resolution capability of the ASDE-2 based on the transmitted pulse width and the azimuth beam width is 20 feet in range and 27 feet in azimuth at 4,000 foot range. Field measurements made of eight installed systems indicate that resolution through the PPI, which includes the operator's determination of target separation, is less precise by a factor of nearly two. Scan conversion results in a further degradation of resolution; by 2 to 1 midrange, and by 3 to 1 at maximum range.

The loss in resolution through scan conversion is primarily due to the 20 MHz bandwidth of each component (vidicon, TV, etc.), which limits the amount of information obtainable from the 50 MHz bandwidth (35 MHz minimum) video distribution circuitry of the ASDE.

The imaging quality of the radar is a function of resolution, pulse repetition frequency, scan rate, detection performance, pulse, and azimuth precisions. The azimuth angular movement per pulse repetition period (PRP = 69  $\mu$ sec) for the 60 rpm scan rate is 0.025° corresponding to about 3 feet at a range of one mile. Timing uncertainties, which relate to range uncertainty, are on the order of 7 feet. Thus, the edge definition of physical targets is considerably better than that indicated by the size of the resolution cell alone, providing the display of a discernable target shape to the controller.

The loss in display quality through the video scan conversion affects the target definition discussed earlier. In addition, the analog scan converter does not have provision for operator-adjustable target trails, depending upon the vidicon decay characteristics. Target update, dictated by scan rate, is once per second.

2. Weather Penetration - The ASDE-2 is capable of displaying small targets out to a 3-nautical-mile range in clear weather. However, in precipitation, coverage is severely restricted due to several effects:

- a. RF path attenuation by precipitation is high at 24 GHz producing "blackout", i.e., loss of valid targets.
- b. RF backscatter radiation from precipitation particles is high at 24 GHz, causing displayed clutter, or "whiteout."
- c. Radome rain sheeting and water absorption increases attenuation loss and echo box effects.

An indication of the expected ASDE performance in heavy rainfall is seen in curve A (CSC<sup>2</sup> shaping) of Figure A-1. Line B represents the minimum signal-to-noise ratio acceptable for 90 percent detection probability for a small target. Under the conditions



shown the radar display would "whiteout" ( i.e., display clutter) within about 1-1/4 nautical miles, and "blackout" beyond 2-3/4 miles. Antenna circular polarization backscatter cancellation is only partially effective in precipitation clutter reduction because of smooth ground surface reflection effects unique to the ASDE environment. Because no adaptive display thresholding system is used, precipitation clutter may be displayed even before total "whiteout" conditions occur.

#### A.5 THE LOS ANGELES GROUND SURVEILLANCE RADAR

The Los Angeles radar was built by Texas Instruments, Inc. based upon a helicopter ground mapping radar and was installed in 1973. Its antenna is covered by a plastic shell that is shaped like a short helicopter blade with an oval cross section, 14 feet long by 6 inches high by 20 inches deep. The antenna needs no radome (it is the oval antenna shell itself) and the entire assembly weighs less than 500 pounds. To offset the adverse effect on rainfall penetration of the wide vertical antenna aperture (due to the short height), the operating frequency has been set at 14 GHz (versus 24 GHz for ASDE-2). While a narrower vertical aperture could have further improved rainfall penetration, the resulting antenna would not have satisfied the light weight requirement. Since bad visibility at Los Angeles is primarily due to fog and haze (and not heavy rainfall), this compromise works out quite well at this site.

The radar is furnished with two independent PPI displays and associated control heads. Each display is approximately 19 inches wide by 19 inches high by 29 inches deep. The display is a direct view PPI equipped with a bright-phosphor tube and the appropriate filters to maximize the brightness. The antenna rotation rate and, therefore, the display refresh rate, are much higher than that for ASDE-2 (i.e., 150 RPM versus 60 RPM). Without TV video scan conversion, the targets have no appreciable trails. However, target detection is enhanced by the flashing effect imposed by the high update rate, particularly for the small hard-to-detect targets.

The control head is approximately 9 inches wide by 7 inches high by 5 inches deep. Range adjustment is continuously variable from 4500 feet to 24,000 feet. Offset is dependent on the range selected (as with ASDE-2) and is continuously variable up to one radius.

#### A.6 DISPLAY ENHANCEMENT UNIT (DEU)

The DEU appears in the video chain, selectively gating display video to allow the display of critical area video (runway, taxiway) while either suppressing or displaying a reduced intensity background video. A stored map of desired airport features to be displayed or suppressed is used in conjunction with azimuth position data (ACP and ARP) and radar pretrigger to properly time the gating commands. The intensity of critical area, background (non-critical area) and synthetic boundary line video can be independently controlled from 0 to 100 percent.

Critical requirements on the DEU design are resolution, registration, and stability. Resolution is the expression of the smallest area that can be suppressed or displayed. Registration is the degree to which the boundary gating coincides with video from the actual critical airport area. Stability is the maintaining of these two performance characteristics over a period of time.

The experimental DEU, built by Texas Instruments, Inc., uses a flying spot scanner analog technique (Figure A-2). A negative of the airport surface which is opaque in the background areas is overlaid on a PPI CRT face. That PPI is synchronized with the PPI of the analog scan converter BRITE display. A photo-multiplier detects light output whenever the sweep passes through a transparent area of the map. The photo-multiplier output is used to generate the video gating signal to provide the display enhancement function.

Boundary lines or map lines are generated by differentiating the transition signals between light and dark areas of the map overlay. Proportional control of gated video provides independent intensities in background and critical area video. Gating is

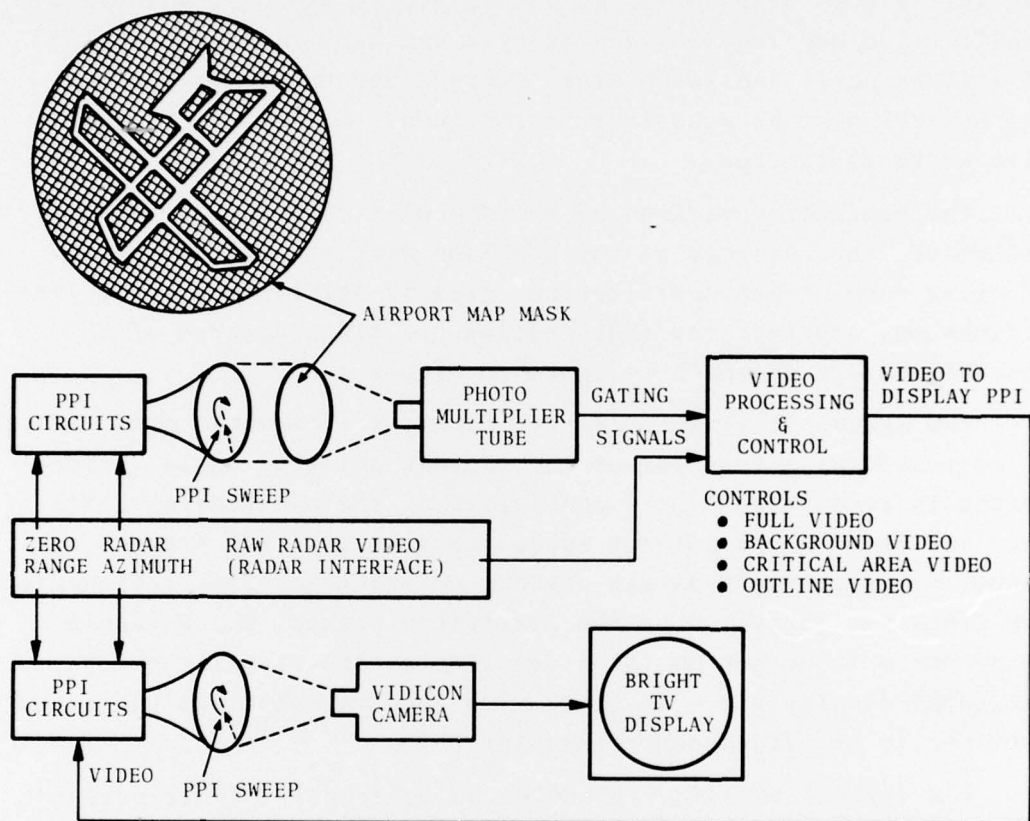

FIGURE A-2 TYPICAL ANALOG DEU

accomplished prior to range scaling and offset, thus not affecting normal display operation.

There are several problems with the above analog technique. Proper registration of the synthetic map with the radar display depends on the initial alignment and the stability of the display. The initial map preparation is a complicated process, and map modification may require generating a new map. Synchronization of azimuth angle and sweep trace timing between the display PPI and DEU PPI must be accurately maintained. Control of boundary line width is limited.

The production version of the DEU will utilize a digital technique, thus overcoming the problems with the analog unit by offering ease of map modification, greater stability, better line definition, and improved registration. A block diagram of a possible design approach is shown in Figure A-3.

The synthetic airport map is stored in a computer memory which is addressed as a function of the antenna pointing angle. Video gating is accomplished by a comparison of the map-generated start/stop values with the current sweep range value. The process continues for each sweep as the antenna pointing angle is incremented. Map lines are generated by the start/stop pulses, which enable a fixed pulse to be put on the video line at the start/stop time. The gated display video is mixed with the synthetic map video and is input to the video scan converter PPI.

The digital technique produces an inherently stable output since an invariable relationship exists between the digital synthetic map memory location and the antenna beam position which is actually involved in imaging the airport surface.

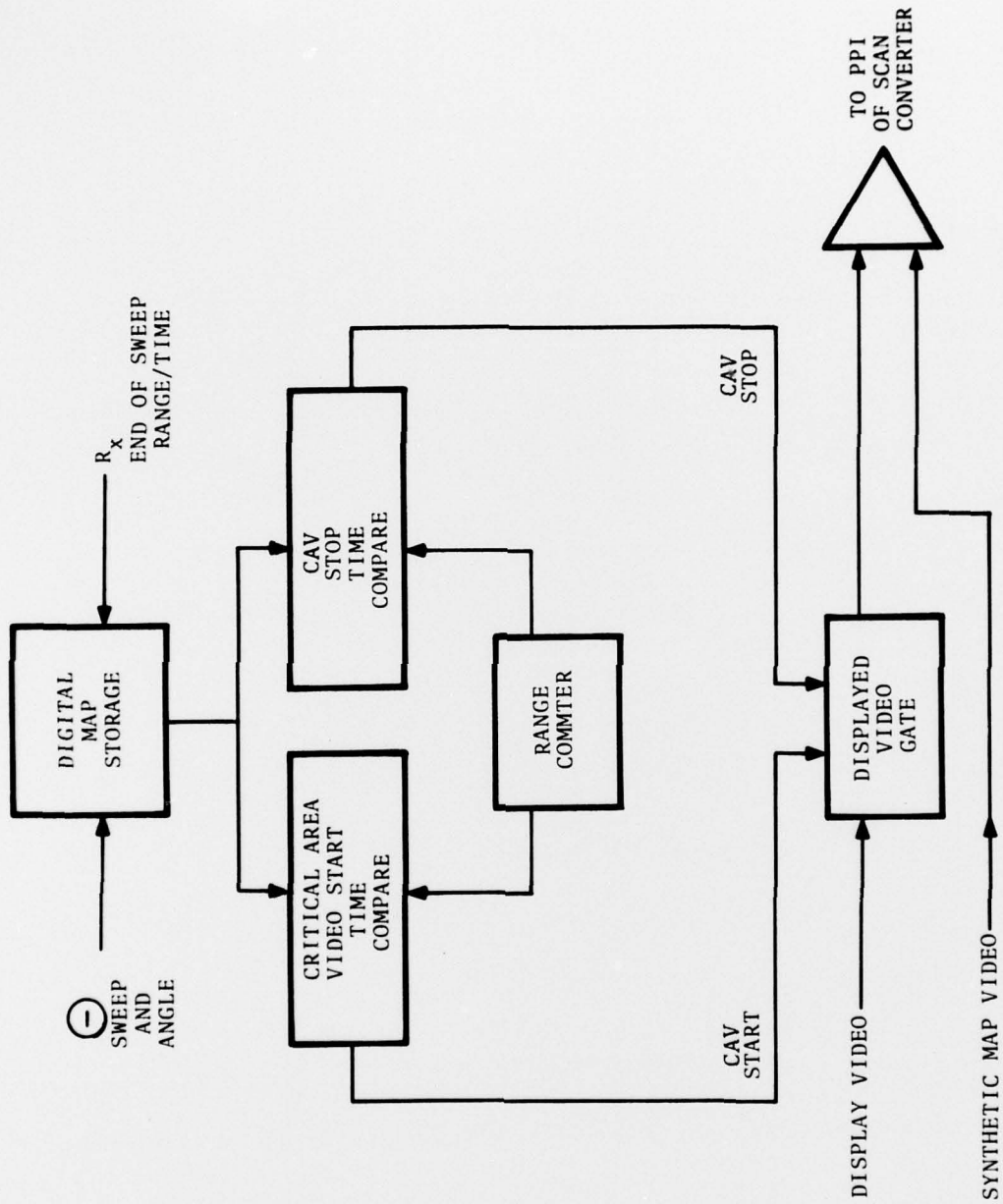

FIGURE A-3 TYPICAL DIGITAL DEU