

AD-A049 128

MICROWAVE ASSOCIATES INC BURLINGTON MASS
MM AND T PROGRAM FOR THE ESTABLISHMENT OF PRODUCTION TECHNIQUES--ETC(U)
AUG 77 R E WALLINE, J L HEATON

F/G 9/1

DAAB07-77-C-0324

UNCLASSIFIED

ECOM-0324-2

NL

1 OF 1
AD
A049128



The microfiche contains 140 frames of technical data. The frames include:

- Textual descriptions and specifications.
- Block diagrams and circuit schematics.
- Graphs showing curves and data points.
- Tables of numerical data.
- Flowcharts and process diagrams.

END
DATE
FILMED
3 - 78
DDC

AD A 049128

72

[Handwritten signature]

AD



Research and Development Technical Report
ECOM - 0324 - 2

AD No. _____
DDC FILE COPY

MM&T Program for the Establishment of
Production Techniques and the Pilot
Production of a High Efficiency,
High Power
GaAs Read Type Impatt Diode

DDC
JAN 24 1978
F

2ND QUARTERLY REPORT

By

DR. R. E. WALLINE DR. J. L. HEATON

AUGUST 1977

DISTRIBUTION STATEMENT
Approved for public release; distribution unlimited.

Monitored by:

ECOM

US ARMY ELECTRONICS COMMAND • FORT MONMOUTH, NEW JERSEY 07703
CONTRACT DAAB07-77-C-0324
MICROWAVE ASSOCIATES, INC.
Burlington, Massachusetts 01803

Disclaimers

The findings in this report are not to be construed as an Official Department of the Army position, unless so designated by other authorized documents.

The citation of trade names and names of manufacturers in this report is not to be construed as Official Government indorsement or approval of commercial products of services referenced herein.

Disposition

Destroy this report when it is no longer needed.
Do not return it to the originator.

TR ECOM 0324-2
August 1977

REPORTS CONTROL SYMBOL
OSD-1366

MM&T PROGRAM FOR THE ESTABLISHMENT OF PRODUCTION TECHNIQUES
AND THE
PILOT PRODUCTION OF A HIGH EFFICIENCY, HIGH POWER
GaAs READ-TYPE IMPATT DIODE.

SECOND QUARTERLY REPORT, no. 2,

29 Apr 1977 - 31 Aug 1977,

CONTRACT NO. DAAB07-77-C-0324

D D C
JAN 24 1978
F

Distribution Statement

Distribution unlimited: Approved for public release

Prepared By

Robert Dr. R. E. / Walline
John Dr. L. / Heaton

11 Aug 77

12 78 p.

MICROWAVE ASSOCIATES, INC.
BURLINGTON, MASSACHUSETTS 01803

FOR

U. S. ARMY ELECTRONICS COMMAND, FORT MONMOUTH, NJ 07703

229 400

1473
mt

UNCLASSIFIED

SECURITY CLASSIFICATION OF THIS PAGE (When Data Entered)

REPORT DOCUMENTATION PAGE		READ INSTRUCTIONS BEFORE COMPLETING FORM
1. REPORT NUMBER ECOM-0324-2	2. GOVT ACCESSION NO.	3. RECIPIENT'S CATALOG NUMBER
4. TITLE (and Subtitle) Manufacturing Methods and Technology for the Establishment of Production Techniques and the Pilot Production of a High Efficiency, High Power GaAs Read-Type IMPATT Diode		5. TYPE OF REPORT & PERIOD COVERED Second Quarterly 29 Apr 1977 - 31 Aug 1977
		6. PERFORMING ORG. REPORT NUMBER
7. AUTHOR(s) Dr. Robert E. Walline Dr. John L. Heaton		8. CONTRACT OR GRANT NUMBER(s) DAAB07-77-C-0324
9. PERFORMING ORGANIZATION NAME AND ADDRESS Microwave Associates, Inc. Burlington, MA 01803		10. PROGRAM ELEMENT, PROJECT, TASK AREA & WORK UNIT NUMBERS 2769738
11. CONTROLLING OFFICE NAME AND ADDRESS U.S. Army Electronics Command Fort Monmouth, NJ 07703		12. REPORT DATE August 1977
		13. NUMBER OF PAGES 81
14. MONITORING AGENCY NAME & ADDRESS (if different from Controlling Office)		15. SECURITY CLASS. (of this report) UNCLASSIFIED
		15a. DECLASSIFICATION/DOWNGRADING SCHEDULE
16. DISTRIBUTION STATEMENT (of this Report) Approved for public release; distribution unlimited.		
17. DISTRIBUTION STATEMENT (of the abstract entered in Block 20, if different from Report)		
18. SUPPLEMENTARY NOTES		
19. KEY WORDS (Continue on reverse side if necessary and identify by block number) READ GALLIUM ARSENIDE IMPATT PROCESS CONTROL EPITAXY COMPUTER CONTROL		
20. ABSTRACT (Continue on reverse side if necessary and identify by block number) An epitaxial GaAs system has been designed for growth of low-high-low GaAs for use in Read-type IMPATT diodes. This epitaxial system includes a computer control system for the operation and monitoring of the epitaxial growth process.		

UNCLASSIFIED

SECURITY CLASSIFICATION OF THIS PAGE(When Data Entered)

REPORT DOCUMENTATION PAGE	
REPORT NUMBER COM-6834-2	REPORT DATE 1977
PERFORMING ORGANIZATION NAME AND ADDRESS Mitsuba Associates, Inc. Burlington, MA 01803	
PERFORMING ORGANIZATION REPORT NUMBER 3788738	
AUTHOR Dr. John I. Hester Dr. Robert E. Waitlin	
CONTRACT OR GRANT NUMBER DAA807-77-C-0024	
PERFORMING ORGANIZATION REPORT NUMBER 3788738	
PROJECT TITLE Development of a High Efficiency, High Power GaAs Read-Type IMPATT Diode	
PERFORMING ORGANIZATION REPORT NUMBER 3788738	
REPORT DATE August 1977	
NUMBER OF PAGES 81	
SECURITY CLASS. (of this report) UNCLASSIFIED	
DISTRIBUTION STATEMENT (of this report) Approved for public release; distribution unlimited.	
SUBJECT TERMS IMPATT EPITAXY COMPUTER CONTROL PROCESS CONTROL GALLUM ARSENIDE	
ABSTRACT An epitaxial GaAs system has been designed for growth of low-high-low GaAs for use in Read-type IMPATT diodes. This epitaxial system includes a computer control system for the operation and monitoring of the epitaxial growth process.	

UNCLASSIFIED

SECURITY CLASSIFICATION OF THIS PAGE(When Data Entered)

TABLE OF CONTENTS

	<u>Page No.</u>
REPORT DOCUMENTATION PAGE (DD Form 1473)	ii
ABSTRACT	ix
I. INTRODUCTION	1
II. SUMMARY	3
III. EXPERIMENTAL RESULTS AND SYSTEM CONSTRUCTION	4
IV. EXPERIMENTAL DEVICE RESULTS	5
A. Device Fabrication	5
B. Device Characterization	7
C. First Engineering Samples	21
V. PROGRAM FOR THE NEXT QUARTER	54
VI. IDENTIFICATION OF PERSONNEL	55
REFERENCES	

ACCESSION for	
NTIS	Write Section <input checked="" type="checkbox"/>
DDC	G.I.F. Section <input type="checkbox"/>
UNANNOUNCED	<input type="checkbox"/>
JUL 1 1971	
BY	
DISTRIBUTION/AVAILABILITY CODES	
SPECIAL	
A	

LIST OF FIGURES

<u>Figure No.</u>		<u>Page No.</u>
1	Apparatus Used to Determine IMPATT Diode DC and rf Parameters	8
2	Standard IMPATT Diode Test Cavity	10
3	Equipment Used in IMPATT Thermal Resistance Measurement	12
4	Apparatus Used in Loaded Q and Noise Measurement	15
5	Circuit Diagram of One Section of 20 Section IMPATT Diode Burn-In Apparatus	19
6	IMPATT Diode Burn-In Rack RF Circuitry	20
7	Doping versus Depth for Engineering Sample Wafer, Portion 1 Measured Using Evaluation Schottky Contacts	22
8	Wafer Schematic Showing Portions Used for Evaluation and Chip Fabrication	24
9	Doping versus Depth for Engineering Sample Wafer, Portion 4 Measured Using Finished Diodes	27
10	Doping versus Depth for Engineering Sample Wafer, Portion 2 Measured Using Finished Diodes	28
11	Doping versus Depth for Engineering Sample Wafer, Portion 3 Measured Using Finished Diodes	29
12	Typical Capacitance versus Voltage Curve for Low-High-Low IMPATT Diode Showing Definition of V^*	30
13	AM Noise versus Frequency Off Carrier, First Engineering Samples, Diode 1	32
14	FM Noise versus Frequency Off Carrier, First Engineering Samples, Diode 1	33
15	AM Noise versus Frequency Off Carrier, First Engineering Samples, Diode 2	34

LIST OF FIGURES (Cont'd)

<u>Figure No.</u>		<u>Page No.</u>
16	FM Noise versus Frequency Off Carrier, First Engineering Samples, Diode 2	35
17	AM Noise versus Frequency Off Carrier, First Engineering Samples, Diode 3	36
18	FM Noise versus Frequency Off Carrier, First Engineering Samples, Diode 3	37
19	AM Noise versus Frequency Off Carrier, First Engineering Samples, Diode 4	38
20	FM Noise versus Frequency Off Carrier, First Engineering Samples, Diode 4	39
21	AM Noise versus Frequency Off Carrier, First Engineering Samples, Diode 5	40
22	FM Noise versus Frequency Off Carrier, First Engineering Samples, Diode 5	41
23	AM Noise versus Frequency Off Carrier, First Engineering Samples, Diode 6	42
24	FM Noise versus Frequency Off Carrier, First Engineering Samples, Diode 6	43
25	AM Noise versus Frequency Off Carrier, First Engineering Samples, Diode 7	44
26	FM Noise versus Frequency Off Carrier, First Engineering Samples, Diode 7	45
27	AM Noise versus Frequency Off Carrier, First Engineering Samples, Diode 8	46
28	FM Noise versus Frequency Off Carrier, First Engineering Samples, Diode 8	47
29	AM Noise versus Frequency Off Carrier, First Engineering Samples, Diode 9	48
30	FM Noise versus Frequency Off Carrier, First Engineering Samples, Diode 9	49

LIST OF FIGURES (Cont'd)

<u>Figure No.</u>		<u>Page No.</u>
31	AM Noise versus Frequency Off Carrier, First Engineering Samples, Diode 10	50
32	FM Noise versus Frequency Off Carrier, First Engineering Samples, Diode 10	51

LIST OF TABLES

<u>Table</u>		<u>Page No.</u>
I	Properties of Epitaxial Wafer used for First Engineering Samples	23
II	Summary of Properties of Various Portions of Wafer Utilized for Engineering Samples	26
III	First Engineering Samples	31
IV	Operating Conditions of Devices on Steady Operating Life Test	53

ABSTRACT

An epitaxial GaAs system has been designed for the growth of low-high-low GaAs for use in Read-type IMPATT diodes. This epitaxial system includes a computer control system for the operation and monitoring of the epitaxial growth process.

I. INTRODUCTION

The purpose of this program is the establishment and verification of techniques to reduce the labor and increase control of processes used in the preparation of epitaxial GaAs and subsequent fabrication of Read-type, Low-High-Low (LHL) GaAs IMPATT diodes. The reduced labor and increased control will be demonstrated by improved manufacturing yields at reduced manufacturing cost. The mechanism by which these improvements are to be obtained is the automation of the epitaxial crystal growth process with appropriate feedback mechanisms which will regulate process variables in accordance with actual conditions. The system is required to control and respond rapidly to variation in wafer temperature, exposure time of the wafer to this temperature, the flow rate of the dopant and epitaxial gases, the chemical composition of these gases and the interrelationship of all these factors. In addition, the epitaxial crystal evaluation (routine) will be eliminated and crystal evaluation (non-routine) will be reduced.

The engineering effort will be restricted to the epitaxial crystal growth and epitaxial crystal evaluation required to produce high-efficiency, Read-type IMPATT diodes plus sample diodes to demonstrate the progress. The success of these control programs will be demonstrated by a pilot line production demonstration of the required X-band diode as defined in SCS-481, dated 23 December 1974.

The epitaxial crystal evaluation will productionize the measurement methods specified for dislocation density of the substrates and buffer layers, doping and uniformity of the substrates and buffer layers, doping profile of the epitaxial LHL crystal, and the thickness of the buffer layer.

A suitable X-band test cavity shall be designed, fabricated and used to test the performance of the diode. The cavity shall incorporate

proper bias circuitry, shall provide easy access to the diode and fast interchangeability of diodes for quick testing. Parts and materials shall be in accordance with MIL-P-11268. Forced air or water cooling shall not be used. The output terminal shall be a standard waveguide terminal mating with flange UG-39/U. The cavity used to test engineering samples shall be identical to that supplied with the samples.

The required wafer yield is fifty percent (50%) of the wafers grown shall have eighty percent (80%), minimum area $3.0 \text{ cm}^2/\text{wafer}$, of usable material. The term usable defines material which meets specifications for dislocation density, doping profile and is capable of producing diodes meeting specification SCS-481. The required diode yield is forty percent (40%) of diodes produced and selected at random from any usable wafer and tested shall meet the cited specification for output power, operating frequency and power efficiency.

In addition, for the X-band diode, performance curves shall be supplied showing typical min-max excursions for capacitance, breakdown voltage, thermal resistance, output power, power efficiency and operating frequency. Diode design and process flow charts covering all process steps for the product shall be detailed.

II. SUMMARY

During the second quarter, the major emphasis was on delivery of the first engineering samples, an analysis of the material grown during the first quarter and continued construction of the epitaxial reactor system and computer control system.

The epitaxial system was shut down for construction of the remainder of the gas handling system for more than half the quarter. All of the work on material evaluation techniques was deferred in order to gain more experience with system operation and to permit additional system construction. Delivery of all of the computer control components was not accomplished until the end of the quarter. As a result, interfacing of the various components could not be accomplished in this period.

The first engineering samples have been delivered. The specifications to be demonstrated by the pilot line production are:

Minimum Output Power:	3.5 watts
Frequency:	9-11 GHz
Efficiency:	20% minimum

The diodes which were provided in the first engineering samples met the following specifications:

Output Power:	2.60 - 3.25 watts
Frequency:	8.0 - 8.4 GHz
Efficiency:	15.3 - 17.0 %

Complete details of these devices are discussed in Section IV.

III. EXPERIMENTAL RESULTS AND SYSTEM CONSTRUCTION

The experimental results of the first quarter were verified during the initial part of the second quarter. An analysis of the material parameters and the device results indicates that the doping peak is not sufficiently sharp in order to manufacture the requisite devices.

This lack of sharpness appears to be the result of the time constant of the mass flow controllers in opening and closing during the peak growth. This difficulty will be overcome when the computer control doping system is completed. The final doping system, which incorporates a bypass valve arrangement with precise timing available from the computer system, will permit sharper peak growth.

The room for the main computer and associated equipment has been completed and the computer has been relocated. The computer and an associated CRT terminal are operational and personnel are becoming familiar with the base computer language and programming.

The remainder of the computer control system was delivered during the final month. Delivery was obtained too late in the month for the equipment to be tested.

The epitaxial system was shut down for much of the quarter to allow the gas handling system to be rebuilt and reconfigured to its final design. The bubbler controller for the AsCl_3 etch bubbler was not satisfactory due to problems with corrosion of the controller as received from the manufacturer. A mass flow controller has been installed for the etch bubbler and will be used over the near term.

IV. EXPERIMENTAL DEVICE RESULTS

A. Device Fabrication

The major features of the device fabrication utilized at Microwave Associates are the use of plated heat sink (PHS) diodes with a nonreactive, high temperature Schottky barrier. A diffusion barrier is incorporated between the Schottky metal and the gold plated heat sink to prevent diffusion of the gold into the Schottky metallization.

The plated heat sink construction was chosen because it is the most consistent process for commercial manufacture of high power devices. Although arguments can be advanced that a thermocompression bonded flip chip diode has a lower theoretical thermal resistance, a more consistent product can be manufactured using the plated heat sink process. In addition, modification of the Schottky characteristics due to the temperature and pressure of the thermocompression bond are avoided and thinner GaAs can be used which minimizes chip series resistance.

The Schottky barrier metallization involves a 200 \AA sputtered platinum layer used because of the superior adhesion of platinum to gallium arsenide, followed by a sputtered barrier layer 2000 \AA thick. The barrier layer does not react with gallium arsenide at temperatures below 450°C . The motion of the Schottky barrier due to metal reaction with gallium arsenide, a known cause of degradation in thick platinum Schottky IMPATTs is prevented [1] by sintering the platinum layer at 425°C for 30 seconds to insure complete reaction of the platinum and gallium arsenide.

The present GaAs PHS process at Microwave Associates is very reliable and reproducible. The process may be divided into a few major steps, which are briefly described below.

Step 1: Schottky-Barrier Junction Formation: After the material is thoroughly cleaned by a back-sputtering process, a layer of platinum (200 Å) is applied and sintered at 425°C for 30 seconds. Then 2000 Å of a tantalum is applied. Finally, 2000 Å of gold is deposited by sputtering.

Step 2: (Gold) Heat Sink Plating: A thick layer (3.5 to 4.5 mils) of high thermal conductivity gold is plated on the sputtered gold surface. The technology involved in the thick metal layer plating has been developed to minimize the bi-metallic built-in mechanical stress, thus avoiding any cracking damage to the GaAs.

Step 3: GaAs Substrate Thinning: The lapping of the n^{++} substrate is followed by a mechanical-chemical thinning process. The GaAs thickness is 25 to 50 microns (depending on frequency of operation) after this thinning operation. This thinning of the GaAs substrate minimizes diode series resistance and the under-cut in mesa etching. The wafer is waxed down to a carrier to facilitate handling during subsequent operations.

Step 4: Back Contact Formation and Mesa Etching: The back contacts are formed by plating palladium, nickel and gold creating reactive Schottky-barrier back contacts. This type of back contact has shown performance that is superior to ohmic back contacts. The Schottky-barrier back contact presents a very high forward-biased capacitance when the diode is properly biased for IMPATT operation, and is almost "transparent" to the microwave signal. Once the back contacts are formed, the area is defined by metal stripping, followed by the mesa etching. The diameter of the mesa junction is usually 1-2 mils larger than that of the back contact.

Step 5: PHS Chip Assembly: The finished wafer is diced into chips when removed from the carrier. The PHS chip bonding is

essentially of the eutectic soldering type, using Au-Sn (80:20) alloy preforms and a hot gas bonder. The preform is melted with a stream of hot forming gas (80% nitrogen, 20% hydrogen) while pressure is applied.

Step 6: Top Contact: Top contact connection is made by thermocompression bonding a 1/2 mil x 5 mil gold strap, in the shape of a "U" to the chip back contact. The free ends of the strap are attached to the package flange. In general, two straps are used and crossover one another at the chip.

Step 7: Diode Capacitance and Breakdown Voltage: Diode capacitance and breakdown voltage are measured and the unit is etched in the package using an electrolytic KOH etch to tailor the mesa profile and adjust the zero bias capacitance to the desired level.

Step 8: Units are capped and delivered for RF testing.

B. Device Characterization

1. Output Power, Frequency, Bias Conditions and Efficiency

Device performance under oscillating conditions is measured using the equipment shown in Figure 1. A calibrated X-band (WR-90) waveguide test kit is used; composed of slide screw tuner, isolator, precision attenuator, frequency meter, two directional couplers for spectrum observation and thermistor mount termination. The line attenuation is precisely calibrated over frequencies of interest. Bias is supplied through a 100 ohm, 25 watt series resistor from a constant voltage supply and is monitored by a digital voltmeter and ammeter.

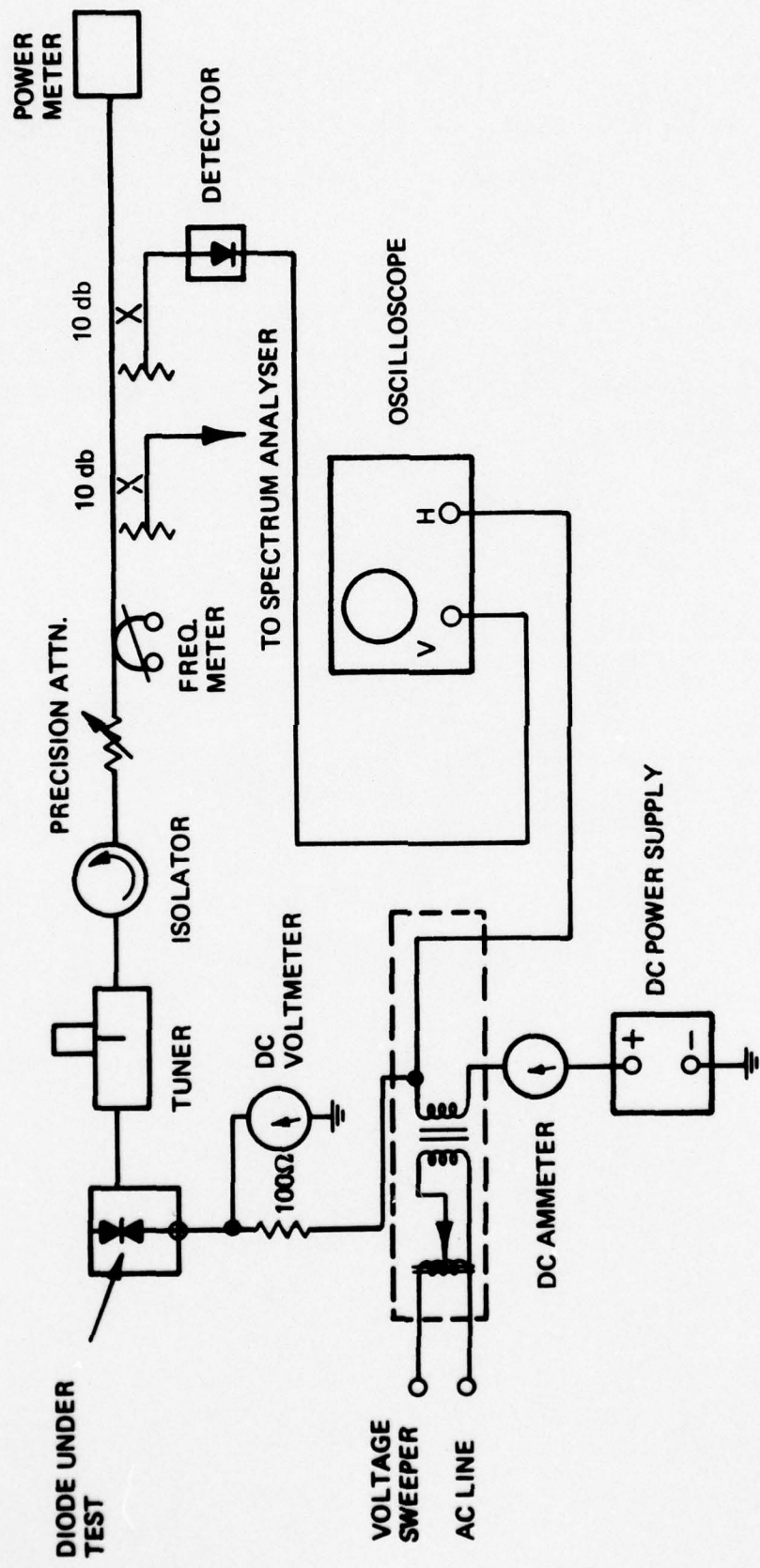

FIGURE 1 APPARATUS USED TO DETERMINE IMPATT DIODE DC AND rf PARAMETERS



2. Test Fixture

The test fixture of Figure 2 is normally used for low-high-low IMPATT diode evaluation.

The test cavity consists of a full height, full width section of WR-90 waveguide terminated at one end in a loose fitting, sliding, shorting plug. Two metal and one dielectric tuning screws are provided. The IMPATT diode is mounted in a silver plated copper threaded holder and placed in the cavity with the bottom of the ceramic flush with the broad waveguide wall. A locking nut insures proper thermal contact between the diode holder and cavity. Bias is supplied through a single section resonant choke assembly and pin extending across the waveguide to contact the top of the diode. Attached to the diode end of the pin is a disc resonator of 0.50 inch diameter. The disc resonator functions as a radial mode waveguide impedance transformer to match the diode impedance (about -10 ohms at resonance) to the waveguide impedance. The cavity resonates when the distance between the tuning screw nearest the output port (front screw) and the diode contact post is one-half of a guided wavelength. The front tuning screw penetration also adjusts the impedance seen by the diode. For proper operation, a significant penetration of the front screw is required.

The middle tuning screw serves as a coarse frequency adjustment (± 250 MHz) by providing a shunt susceptance at a point of high electric field in the cavity. Some impedance change also occurs in tuning with the middle screw, necessitating readjustment of the front screw. The dielectric screw provides a fine-frequency adjustment (about 50 MHz) without significant impedance change. If sufficient penetration of the front screw is used, diode operation becomes almost

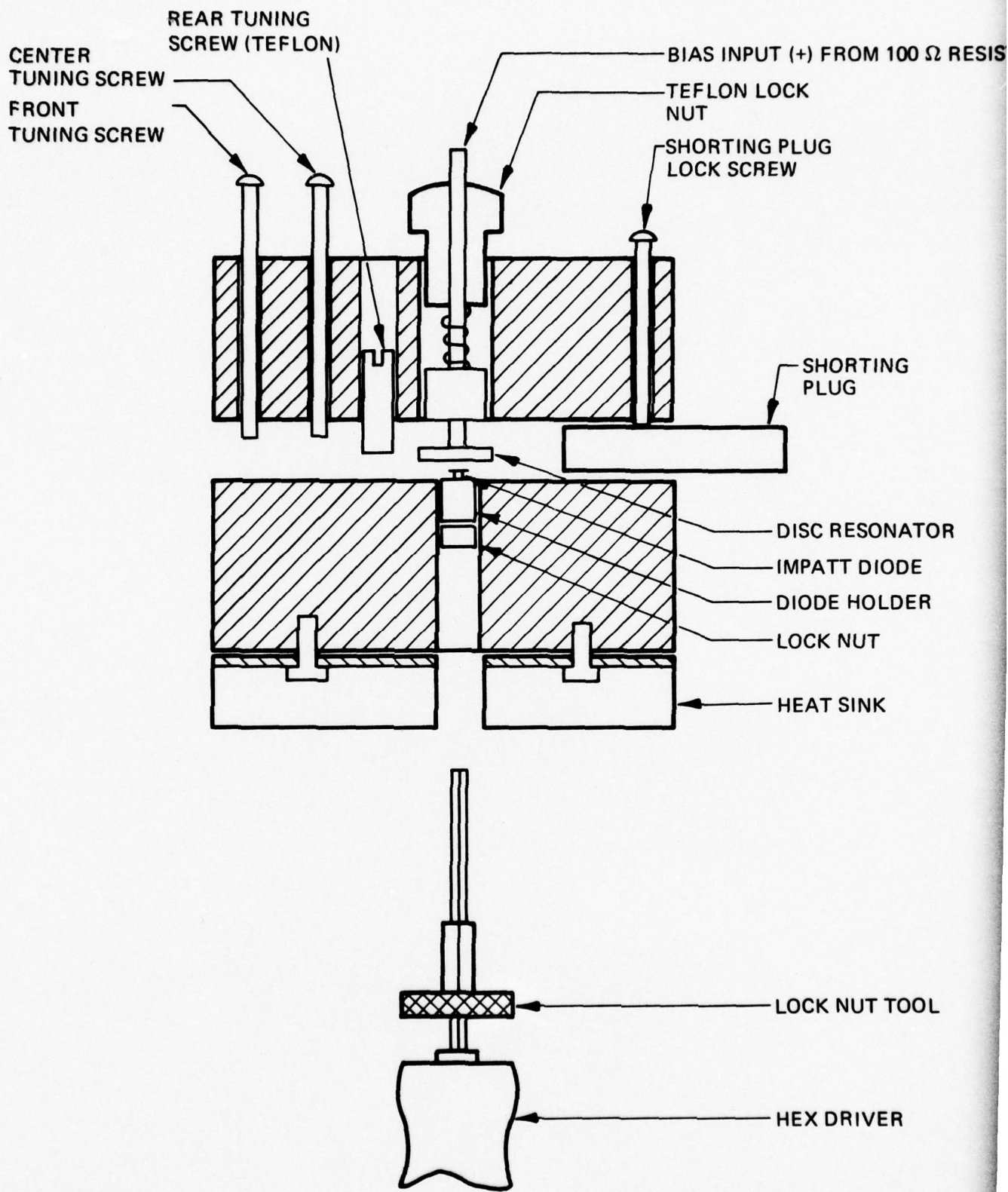

FIGURE 2 STANDARD IMPATT DIODE TEST CAVITY

insensitive to the position of the sliding short plug. Some improvement in efficiency can be obtained by fine-tuning the shorting plug, probably because of its effect on higher-order harmonic tuning.

3. Thermal Resistance Measurement

The IMPATT diode thermal resistance measurement used at Microwave Associates is based on the temperature dependence of the diode breakdown voltage

$$V_B(T_j) = K_T(T_j - T_C) + V_{BO} \quad (1)$$

where

- T_j = junction temperature, $^{\circ}\text{C}$
- T_C = initial junction temperature
(equal to case temperature) $^{\circ}\text{C}$
- V_{BO} = breakdown voltage at $T_j = T_C$
- K_T = temperature coefficient of the
breakdown voltage, $(\text{V}/^{\circ}\text{C})$

The circuit of Figure 3 is used. The diode to be measured is placed in a test fixture and biased at normal average power input. Oscillations are suppressed by use of graphite load material in the diode mount. A negative-voltage pulse of 1.0 microsecond duration is introduced across the diode and its amplitude adjusted until the diode peak pulse current equals the DC current. The pulse voltage required at the diode is then subtracted from the applied DC voltage to give a breakdown voltage value, measured with the junction at normal operating temperature. Because the pulse duration is much less than chip thermal time constant, negligible cooling occurs. Using Equation (1), a value for T_j and thus, the diode thermal resistance, θ , may be calculated if K_T is known. K_T may be measured by removing DC bias and applying external heat to the diode, while observing the

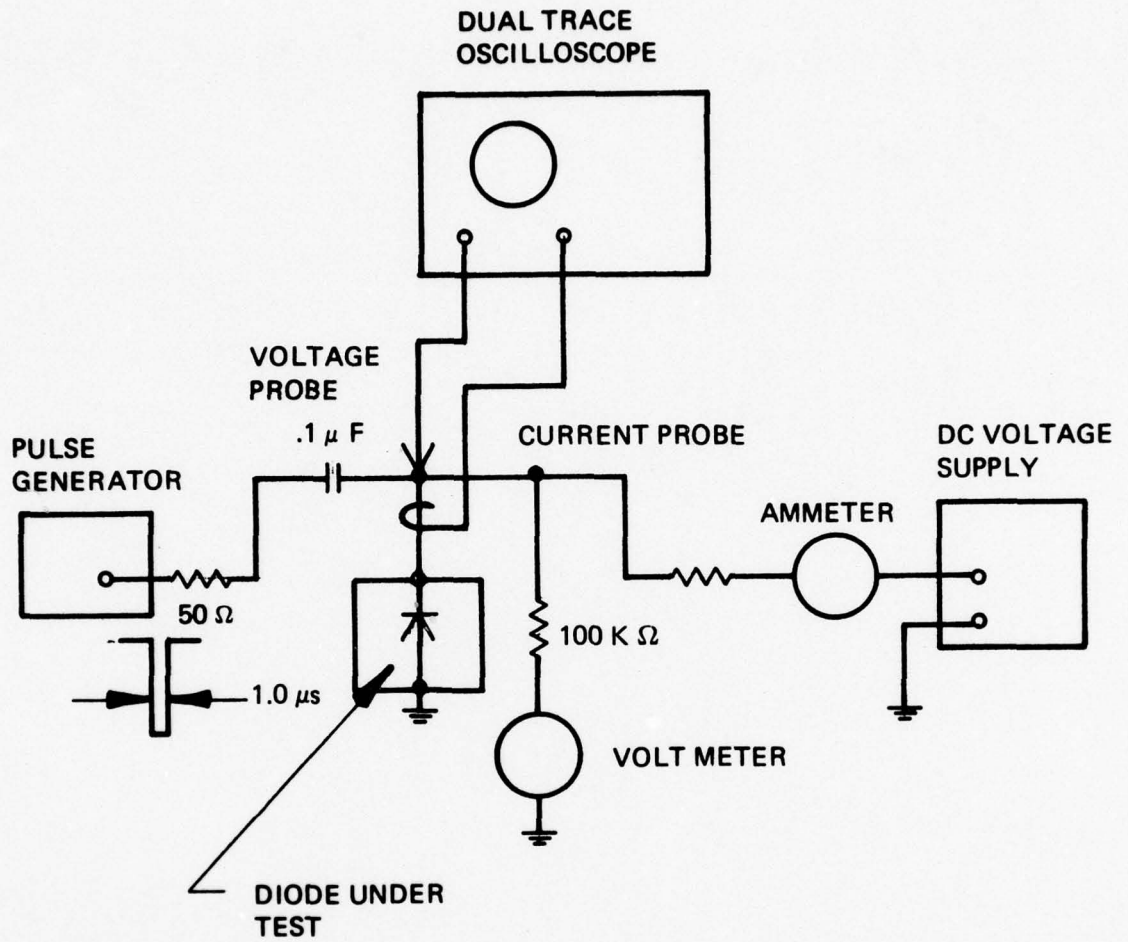

FIGURE 3 EQUIPMENT USED IN IMPATT THERMAL RESISTANCE MEASUREMENT

pulsed breakdown voltage, using the circuit of Figure 3. In practice, several V_B versus T_C plot points are measured for a few sample diodes from a given wafer and K_T determined from a best fit line drawn on a V_B versus T_C plot. Case temperatures of 100, 150 and 200°C are used. The value of K_T obtained is then used to characterize the thermal resistance of other diodes from the wafer.

If a small DC current (say 1 mA) is used instead of a pulse measurement to obtain V_T versus T_C data, errors are introduced in the case of diodes with soft breakdowns. The pulse measurement allows determination of the true breakdown (by extrapolation of the current back to zero volts) without introducing self-heating. Thermal resistance is computed from Equation (2) as follows:

$$\theta_j = \left[\frac{V_B - V_{BO}}{K_T} + T_{co} - T_C \right] \frac{1}{V_{DC} I_{DC}} \quad (2)$$

where

- V_B = breakdown voltage measured under operating conditions using 1.0 μ sec pulses, volts
- V_{BO} = breakdown voltage measured with DC voltage turned off, using 1.0 μ sec pulse, volts
- T_C = diode case temperature during operation, °C
- V_{DC} = diode operating voltage, volts
- I_{DC} = diode operating current, amperes
- K_T = temperature coefficient of the breakdown voltage, volts/°C
- T_{co} = diode case temperature with DC voltage turned off, when V_{BO} was measured, °C

A correction has been made for the fact that case temperature during operation rises above the case temperature observed when measuring V_{BO} .

4. Noise and Loaded Q Measurements

Because oscillator FM noise varies approximately inversely with loaded Q, it is necessary that the FM noise and loaded Q be measured sequentially without changing diode or cavity tuning. Because diode performance is quite sensitive to residual test equipment mismatch, it is advisable to measure Q and FM noise using the same test kit. The equipment used to make the noise and Q measurements are shown in Figure 4. A signal source monitored by a directional coupler and power meter is circulator-coupled to the test cavity. The output power and spectrum of the oscillator are monitored using a pair of directional couplers in the circulator output arm.

The external Q of the diode test fixture is measured by performing an injection locking measurement. The test fixture loaded Q is calculated as follows:

$$Q_L = \frac{2f_o}{\Delta f} \sqrt{\frac{P_{in}}{P_{out}}} \quad (3)$$

where

Q_L = test fixture loaded Q

f_o = test fixture free running frequency of oscillation (MHz)

Δf = total locking bandwidth (MHz)

P_{in} = input locking signal (30 mW)

P_{out} = oscillator output power with locking source off

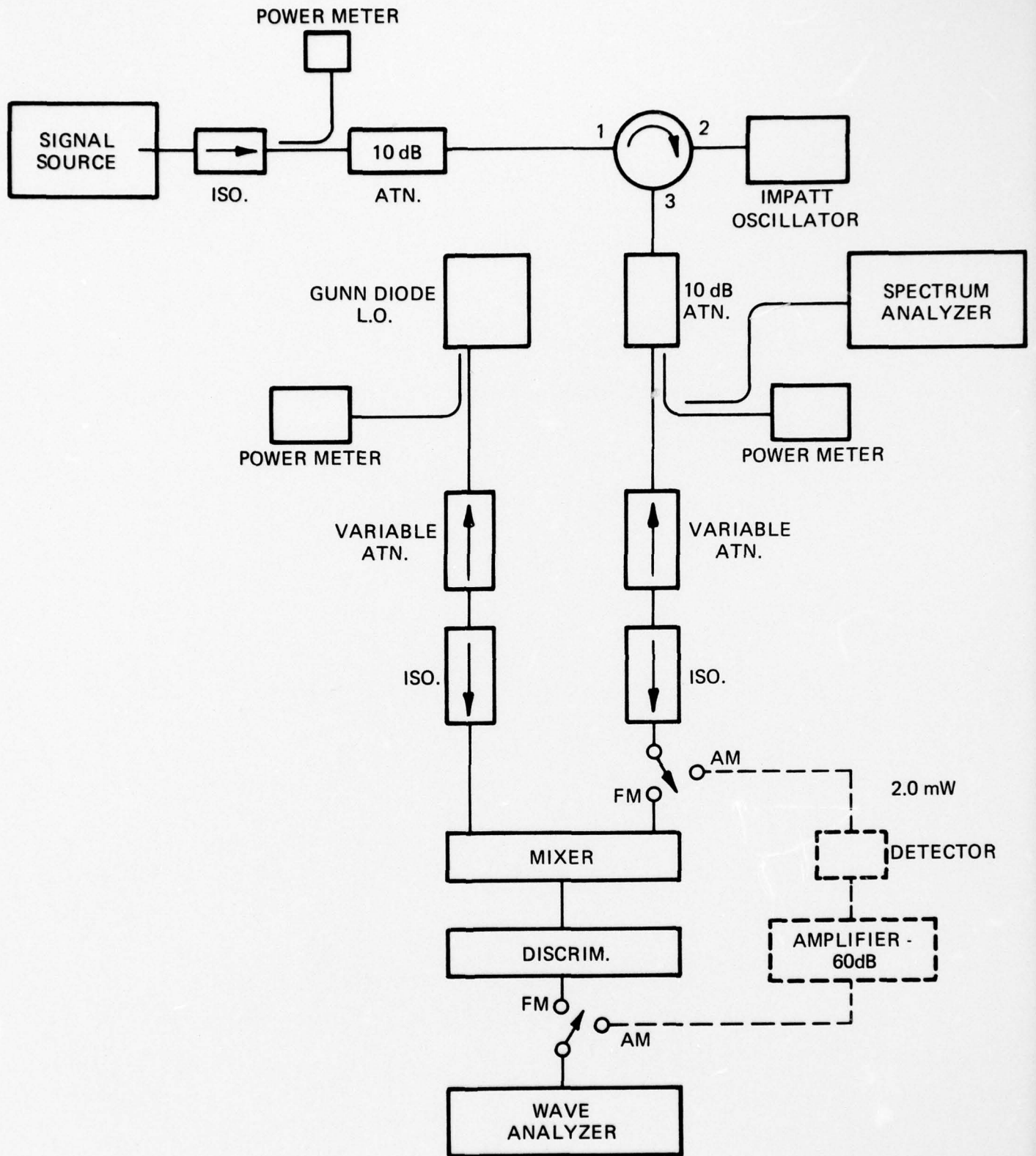

FIGURE 4 APPARATUS USED IN LOADED Q AND NOISE MEASUREMENT

The external Q (Q_{ext}) is calculated as follows:

$$\frac{1}{Q_{\text{ext}}} = \frac{1}{Q_L} - \frac{1}{Q_o} \quad (4)$$

where

Q_{ext} = test fixture external Q

Q_o = test fixture unloaded Q

It will be assumed that $Q_o \gg Q_L$ and that $Q_{\text{ext}} \approx Q_L$.

The FM noise measurement is made using the heterodyne technique. A very low noise Gunn diode oscillator is mixed with the test signal to produce a 1 MHz IF frequency. An HP discriminator is used to convert the FM noise sidebands to AM, allowing measurement in a specified bandwidth (1000 or 3000 Hz) at various frequencies off carrier using an HP wave analyzer. The system is calibrated by using the Crosby zero crossing method.⁽²⁾ With an FM signal generator connected in place of the test oscillator, the peak deviation is increased until the first null in the carrier is detected on the spectrum analyzer. This produces a known peak deviation given by

$$\Delta f_{\text{peak}} = 2.405 f_v \quad (5)$$

where

Δf_{peak} = peak frequency deviation

f_v = modulation frequency

The system sensitivity is determined by measuring the corresponding output voltage on the wave analyzer. The measured noise voltage may

then be converted to rms deviation as follows:

$$\Delta f_{\text{rms}} = \frac{v_N}{\sqrt{2} v_{\text{cal}}} \times 2.405 f_v \quad (6)$$

where

Δf_{rms} = rms FM noise deviating (Hz)

v_N = measured noise voltage

v_{cal} = measured calibration voltage when carrier null occurs

AM noise measurements are made by replacing the mixer with a single ended detector followed by a 60 dB amplifier connected to the wave analyzer. Because the AM noise sidebands are typically 50 dB smaller than the FM noise sidebands, it is necessary to correct for system background noise. This is done by recording the AM noise when the test oscillator is replaced with the very low noise Gunn diode oscillator (with appropriate changes in attenuation to provide 1 mW at the detector). These readings are then used to correct the values obtained from the test oscillator. AM calibration is accomplished by noting the change in detector output voltage for a 0.2 mW change in detector power. AM noise is computed as follows:

$$\frac{N}{S} \text{ (dB)} = 10 \log \frac{(V_N^2 - V_B^2)}{(2 S_u P_C G)^2} \quad (7)$$

where

$\frac{N}{S}$ (dB) = noise power to carrier power ratio, dB (double sideband)

V_N	=	measured test oscillator noise voltage
V_B	=	measured background noise voltage
S_u	=	detector sensitivity (V/W)
P_c	=	carrier power level (W), usually 1 mW
G	=	amplifier gain (ratio), usually 1000

5. Operating Life Test

The steady state operating life test will utilize the equipment shown in Figures 5 and 6. Each diode is mounted in an individual oscillator of the type shown in Figure 2, and connected to a waveguide to coaxial transition, a 20 dB, 5 watt coaxial attenuator, and waveguide detector. The detector outputs are monitored by a multipoint chart recorder. Bias is supplied from a regulated supply through 100 ohm, 25 watt adjustable series resistors. The operating point of each device may be individually monitored using a multi-position switch. A sensing circuit in each position senses open or short condition and shuts the position off in case of diode failure. Individual elapsed time meters record hours of operation. In addition, an automatic restart circuit delays turn-on of the kit by 10 seconds following power line failure, to allow any power supply transients to end before connection of the devices.

Device temperature is controlled through forced air cooling. The test oscillators are mounted on a section of extended aluminum heat sink stock, and cooled by a three-section fan assembly.

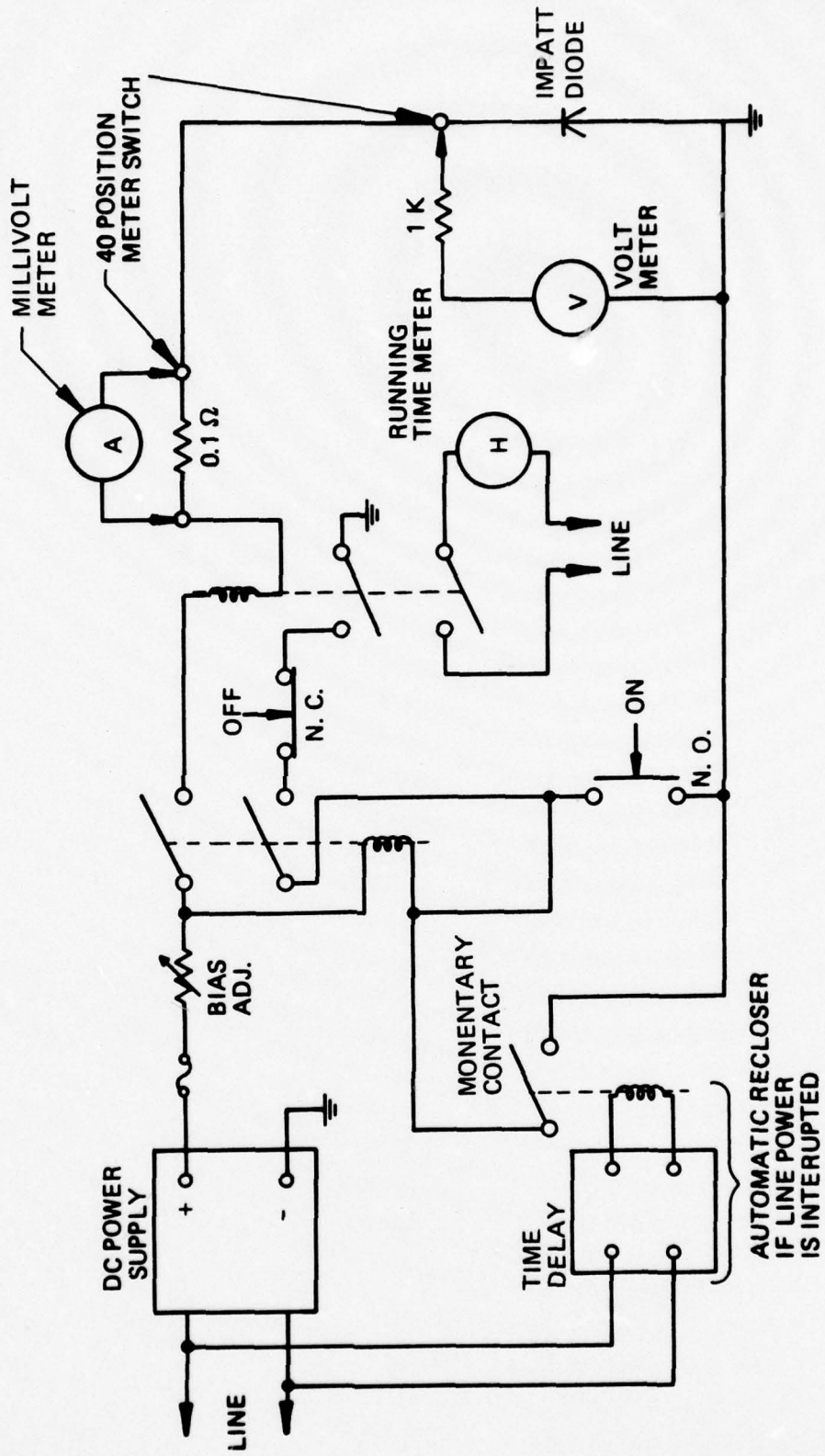

FIGURE 5 CIRCUIT DIAGRAM OF ONE SECTION OF 20 SECTION IMPATT DIODE BURN-IN APPARATUS

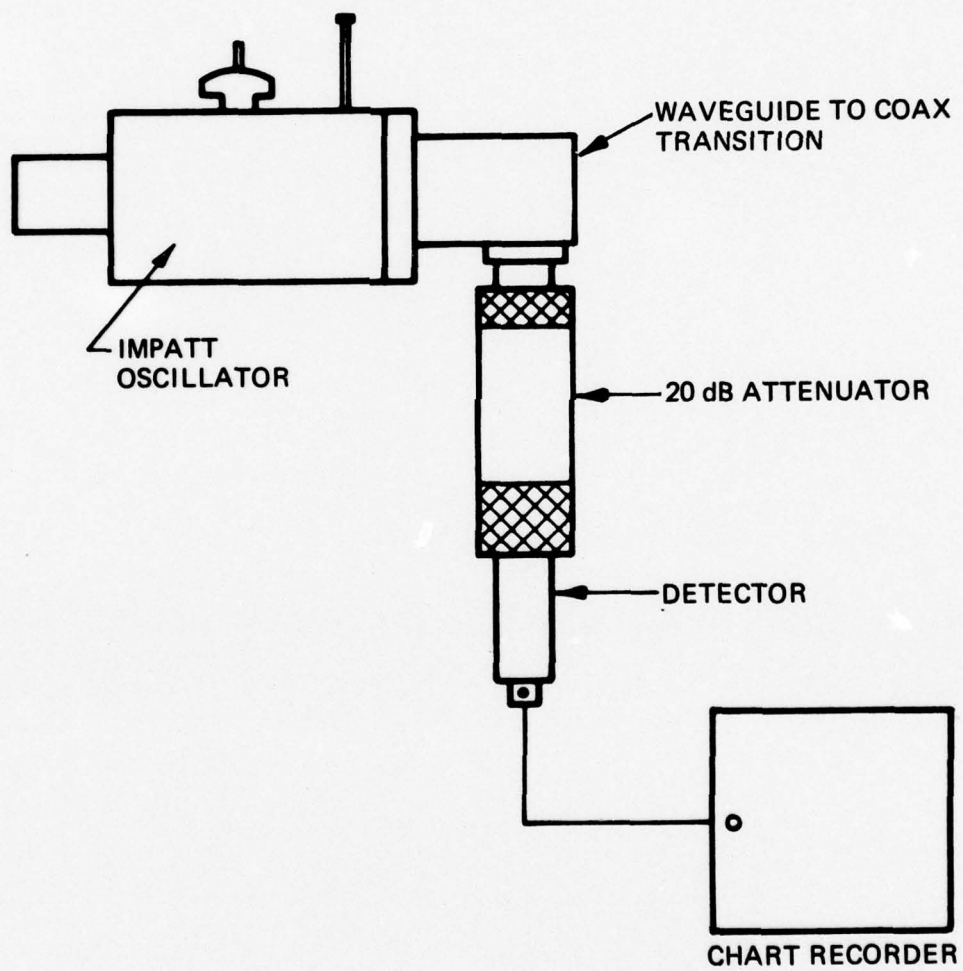
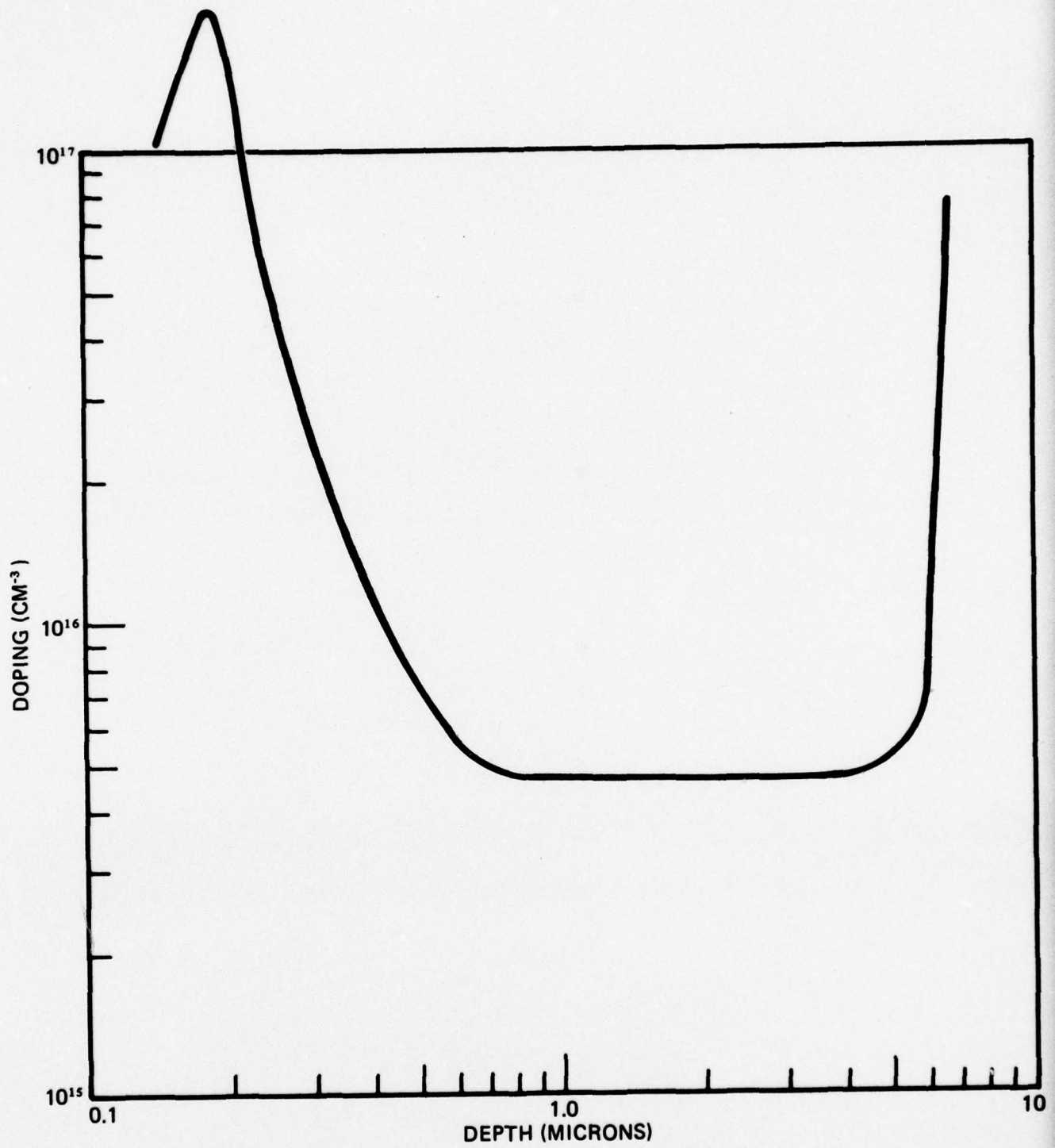

FIGURE 6 IMPATT DIODE BURN-IN RACK RF CIRCUITRY

C. First Engineering Samples

The first engineering samples were fabricated from a wafer grown prior to completion of the fully automatic reactor system. Because the reactor had only been partially converted to automatic control, the material parameters were not optimized. The doping profile of the wafer is presented in Figure 7 and a summary of wafer properties in Table I. The profile shown was measured using 20 mil diameter evaporated aluminum Schottky diodes on an evaluation piece cleaved from the top of the wafer (see Figure 8). The entire profile was obtained by sequentially step-etching the evaluation portion before applying the evaluation Schottky barrier diodes. Non-destruction thickness measurements were made at five positions on the wafer surface using IR reflectance techniques.

Evaluation diodes were made from portions #3 and 4 (see Figure 8). These chips are not of the plated heat sink type but are simply scribed and cleaved seven mil square pads. They are thermo-compression bonded into packages and provide quick evaluation of potential wafer performance without resorting to the lengthy PHS process. The amount of sputter etch required for proper peak location may be determined in this fashion. Profiles can also be made on the completed diodes, allowing determination of the wafer uniformity with respect to peak position and height. Because of diode breakdown, the drift region cannot be profiled on finished devices. The accuracy of profile measurements made on finished devices is critically dependent on device area since the square of the device area is a multiplicative factor. Because the device area is generally much smaller than that of the evaluation Schottkys, profiles based on device measurements generally exhibit some scatter.

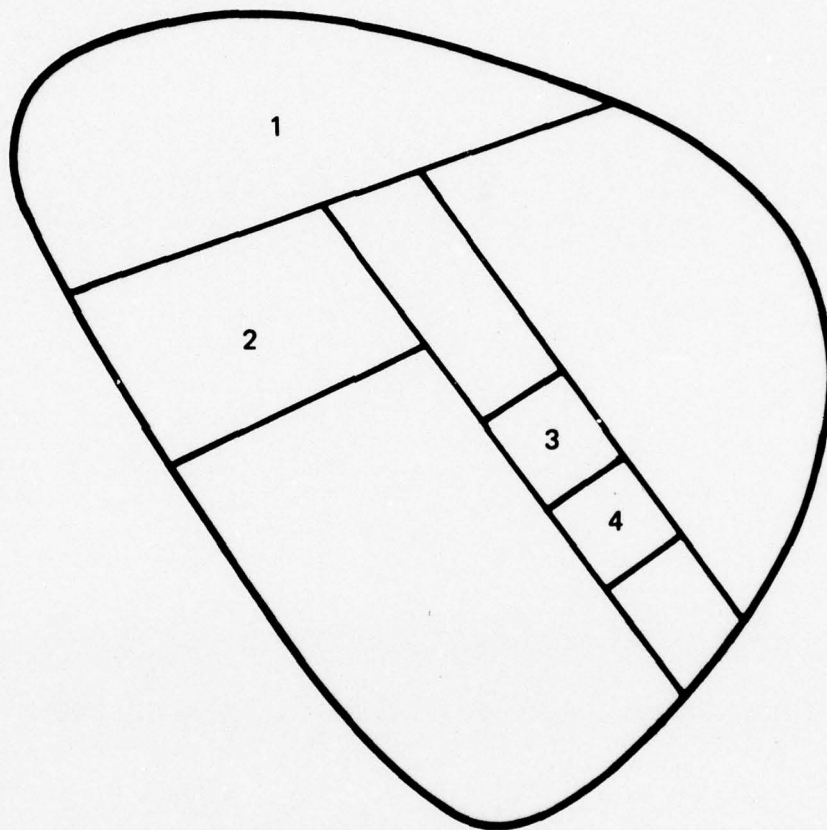

**FIGURE 7 DOPING vs. DEPTH FOR ENGINEERING SAMPLE WAFER,
PORTION 1 MEASURED USING EVALUATION
SCHOTTKY CONTACTS**

PROPERTY	MEASUREMENT
Drift Carrier Density	$4.8 \times 10^{15} \text{ cm}^{-2}$
Total Epi Thickness	6.6 microns
Peak Height	$2.0 \times 10^{17} \text{ cm}^{-3}$
Peak Position	0.19 micron
Zero Bias Carrier Density	$1.0 \times 10^{17} \text{ cm}^{-3}$

Table I. Properties of Epitaxial Wafer used for First Engineering Samples

NOTE: Data in this chart were obtained from profile measurements made on the evaluation portion of the wafer (Section #1, Figure 8).



1. MATERIAL EVALUATION
2. PHS CHIP FABRICATION
3. SECOND EVALUATION CHIP FABRICATION
4. FIRST EVALUATION CHIP FABRICATION

FIGURE 8 WAFER SCHEMATIC SHOWING PORTIONS USED FOR EVALUATION AND CHIP FABRICATION

Table II presents data measured on the two lots of evaluation diodes as well as the plated heat sink devices fabricated from portion #2 (see Figure 8). Representative doping profiles appear in Figures 9, 10 and 11. The amount of etch for peak location has been estimated from sputter etching time, assuming a constant etch rate. The quantity V^* in Table II is best defined by reference to a typical low-high-low IMPATT capacitance versus voltage plot shown in Figure 12. V^* is a measure of the integrated charge under the doping peak and has been found to lie in the 8 to 12 volt range for usable wafers.

The ten devices shipped as the first engineering samples were constructed using the PHS chips from portion #2 of the wafer. The devices were sealed and burned in for 168 hours at 15 watts of input power and 75°C case temperature in a DC burn-in rack. Following burn-in, the detailed RF performance data of Table III was recorded using the test fixture of Figure 2. A diode case temperature of 40°C was maintained during these tests. Thermal resistance was also measured and the results appear in Table III.

Diode output power varied from 2.6 to 3.2 watts at 15.3% to 17% efficiency. Operating frequency was low varying from 8.0 to 8.38 GHz. However, thermal resistance was quite acceptable, ranging from 8.3 to $10.5^{\circ}\text{C}/\text{watt}$.

The results of the noise measurements made on the engineering sample units are shown in Figures 13 through 32. It was found that a significant reduction (by a factor of 3 to 4) in FM noise deviation could be achieved by tuning the oscillator for lowest noise sidebands as observed on a spectrum analyzer, rather than for maximum output power. An accompanying $1/2$ dB reduction in output power and increase in loaded Q also occurred. In some cases, Q values

PORION	AMOUNT OF ETCH (microns)	FINAL PEAK POSITION (microns)	FINAL PEAK HEIGHT (cm ⁻³)	ZERO BIAS CARRIER DENSITY (cm ⁻³)	V* (Volts)	POWER OUTPUT (Watts)	EFFICIENCY (%)
Evaluation 1 (#4, Figure 8)	none	0.64	1.8 x 10 ¹⁷	1.2 x 10 ¹⁶	18	1.3	13%
Evaluation 2 (#3, Figure 8)	0.1	0.45	1.7 x 10 ¹⁷	2.2 x 10 ¹⁶	11.2	0.8	15%
PHS (#2, Figure 8)	0.1	0.46	2.3 x 10 ¹⁷	2.7 x 10 ¹⁶	13	3.0	16%

Table II. Summary of Properties of Various Portions of Wafer Utilized for Engineering Samples

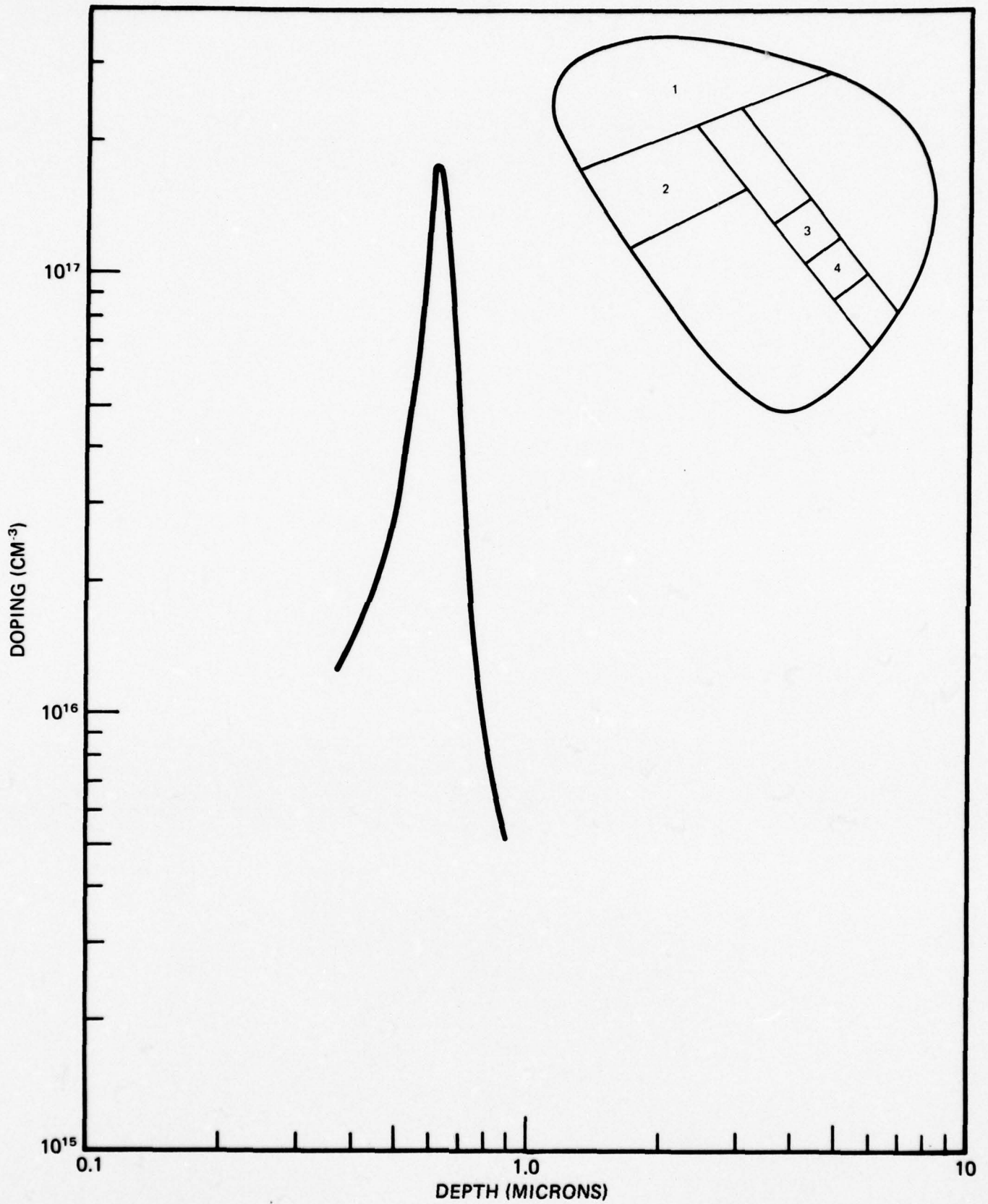

**FIGURE 9 DOPING vs. DEPTH FOR ENGINEERING SAMPLE WAFER,
PORTION 4 MEASURED USING FINISHED DIODES**

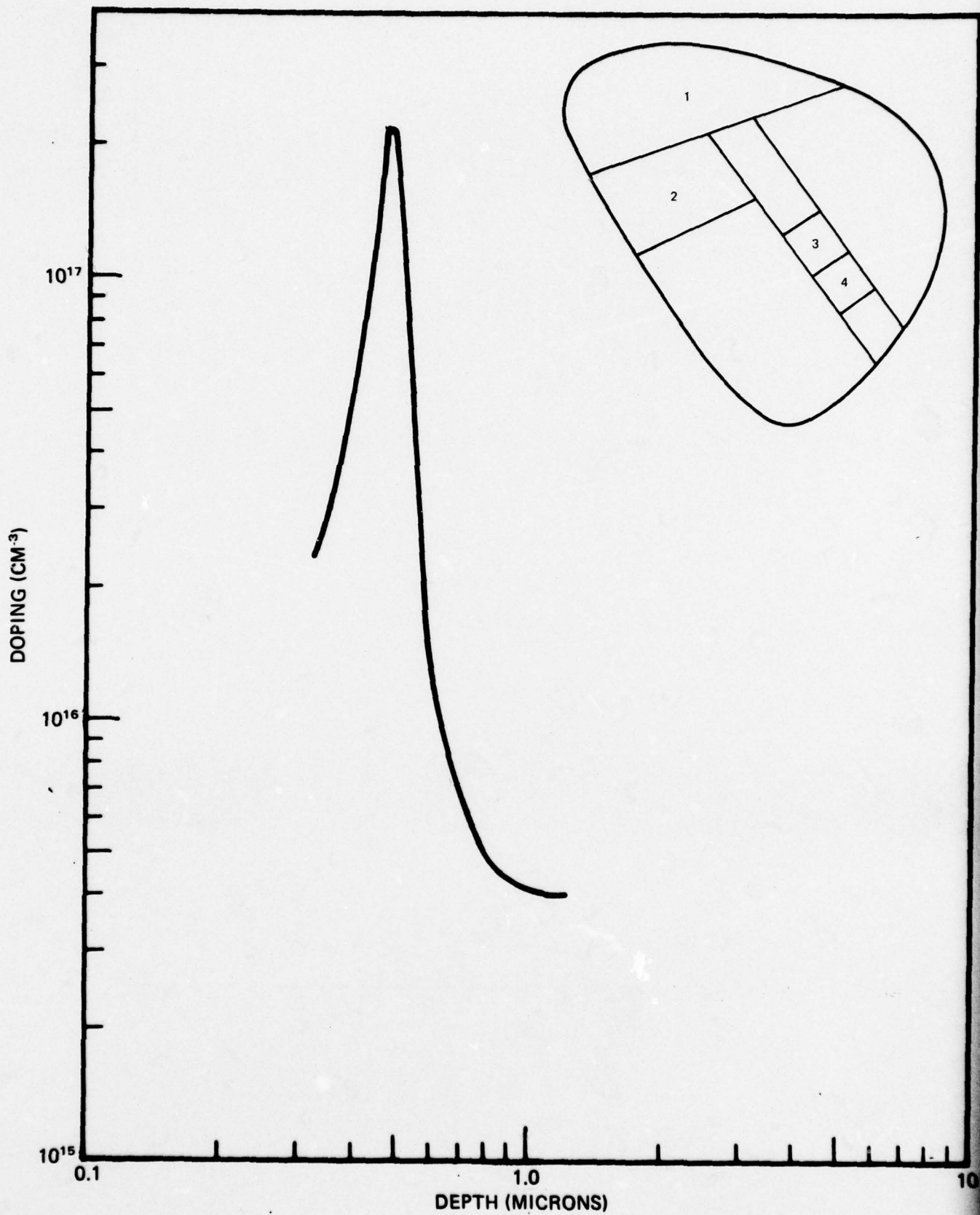

FIGURE 10 DOPING vs. DEPTH FOR ENGINEERING SAMPLE WAFER, PORTION 2 MEASURED USING FINISHED DIODES

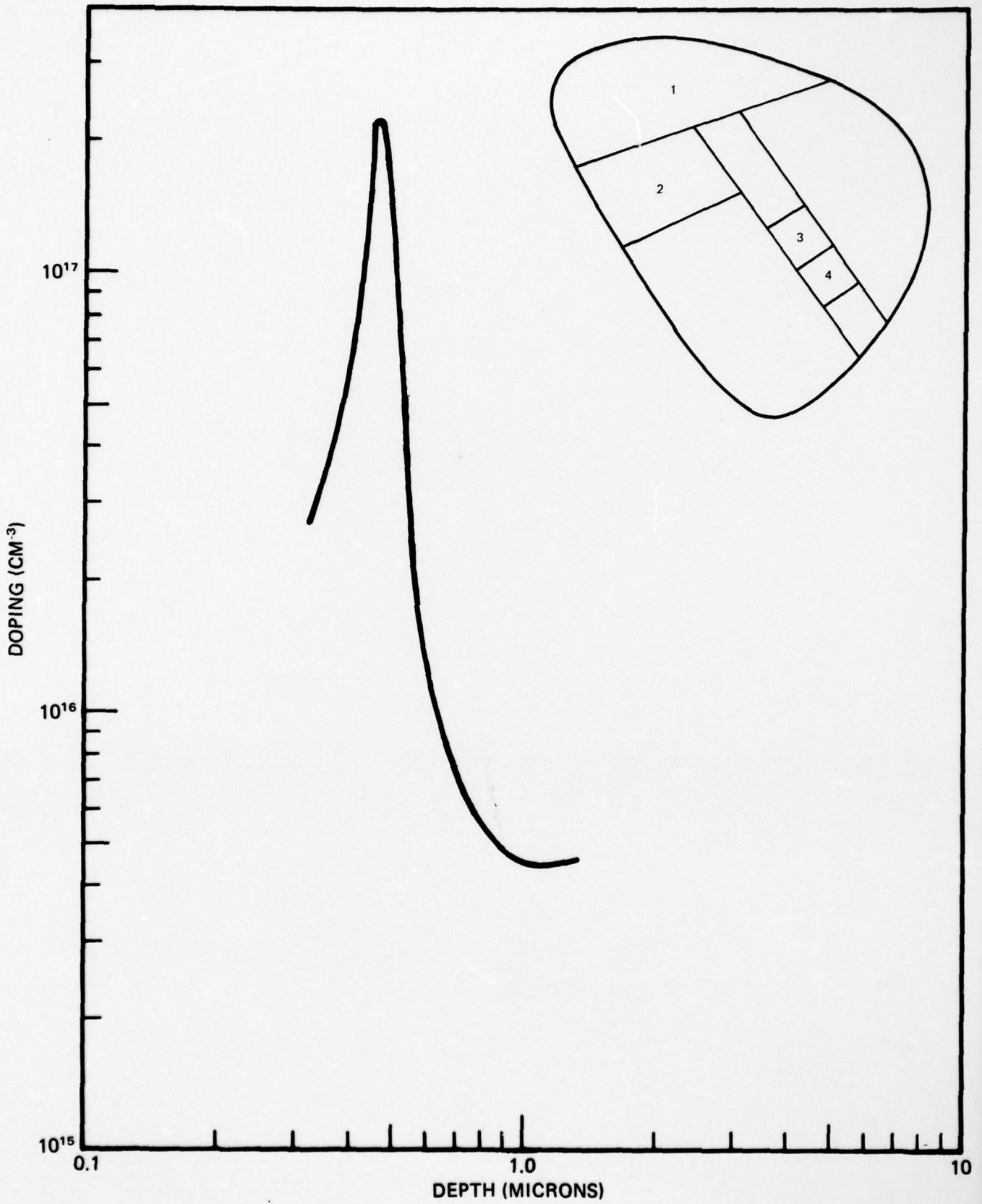

FIGURE 11 DOPING vs. DEPTH FOR ENGINEERING SAMPLE WAFER, PORTION 3 MEASURED USING FINISHED DIODES

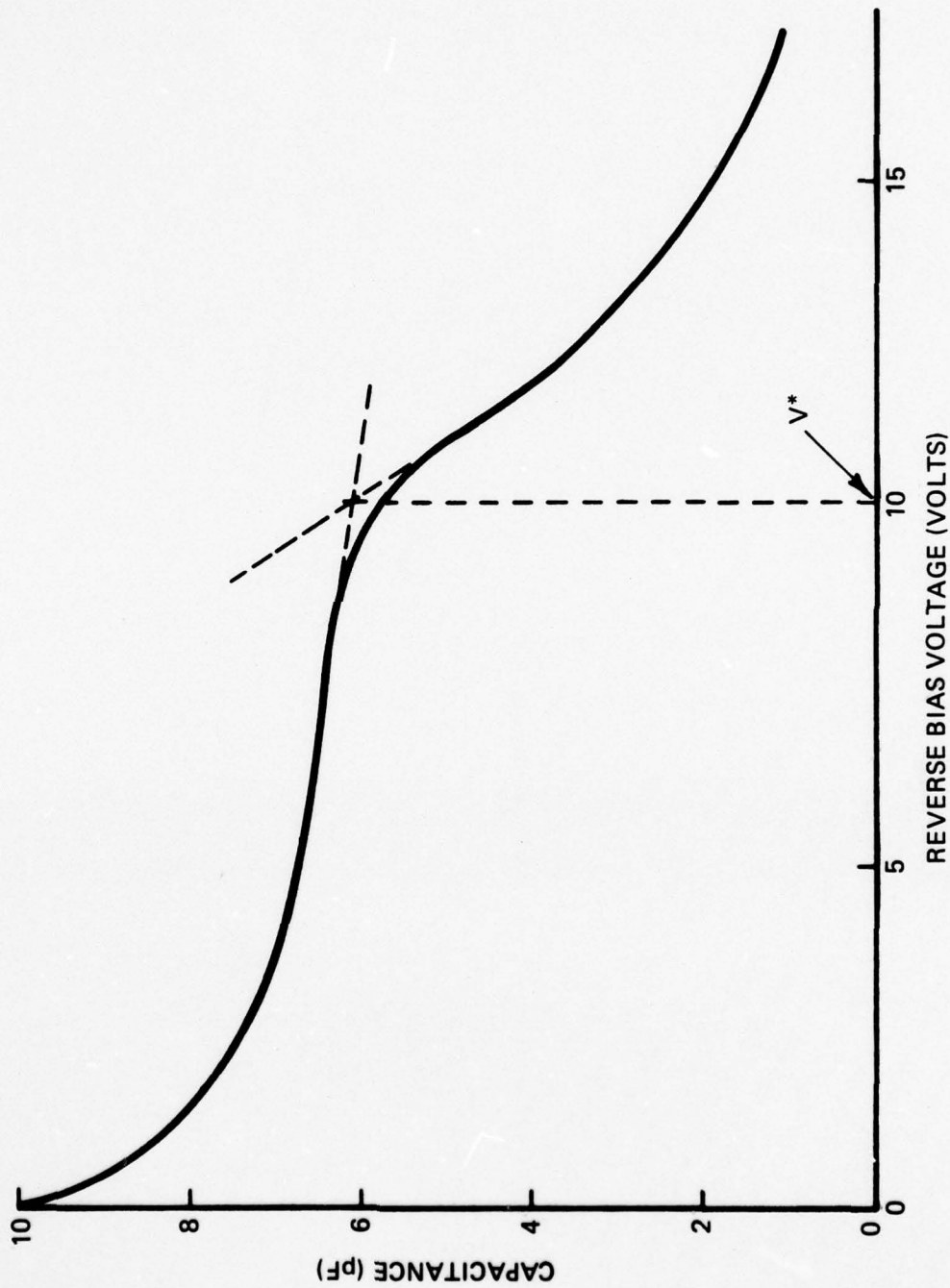

FIGURE 12 TYPICAL CAPACITANCE VERSUS VOLTAGE CURVE FOR LOW-HIGH-LOW IMPATT DIODE SHOWING DEFINITION OF V^*

DEVICE #	V_B (Volts)	C_{TO} (pF)	V_o (Volts)	I_o (mA)	P_o (mW)	f_o (GHz)	θ ($^{\circ}C/W$)	n (%)
1	23.4	12.2	56.1	325	2950	8.125	10.3	16.2
2	24.4	13.8	56.7	320	2900	8.050	10.5	16.0
3	23.4	12.2	52.3	365	3250	8.000	8.7	17.0
4	22.5	13.4	56.0	340	2925	8.070	9.6	15.4
5	23.8	11.4	55.1	300	2650	8.26	9.1	16.0
6	24.6	12.0	56.3	310	2750	8.19	9.3	15.8
7	24.6	11.1	54.8	300	2750	8.20	9.4	16.7
8	22.3	11.2	51.4	330	2600	8.28	9.0	15.3
9	24.0	12.2	54.4	330	2950	8.08	8.3	16.4
10	23.2	11.3	54.0	310	2700	8.38	9.3	16.1

Table III. First Engineering Samples

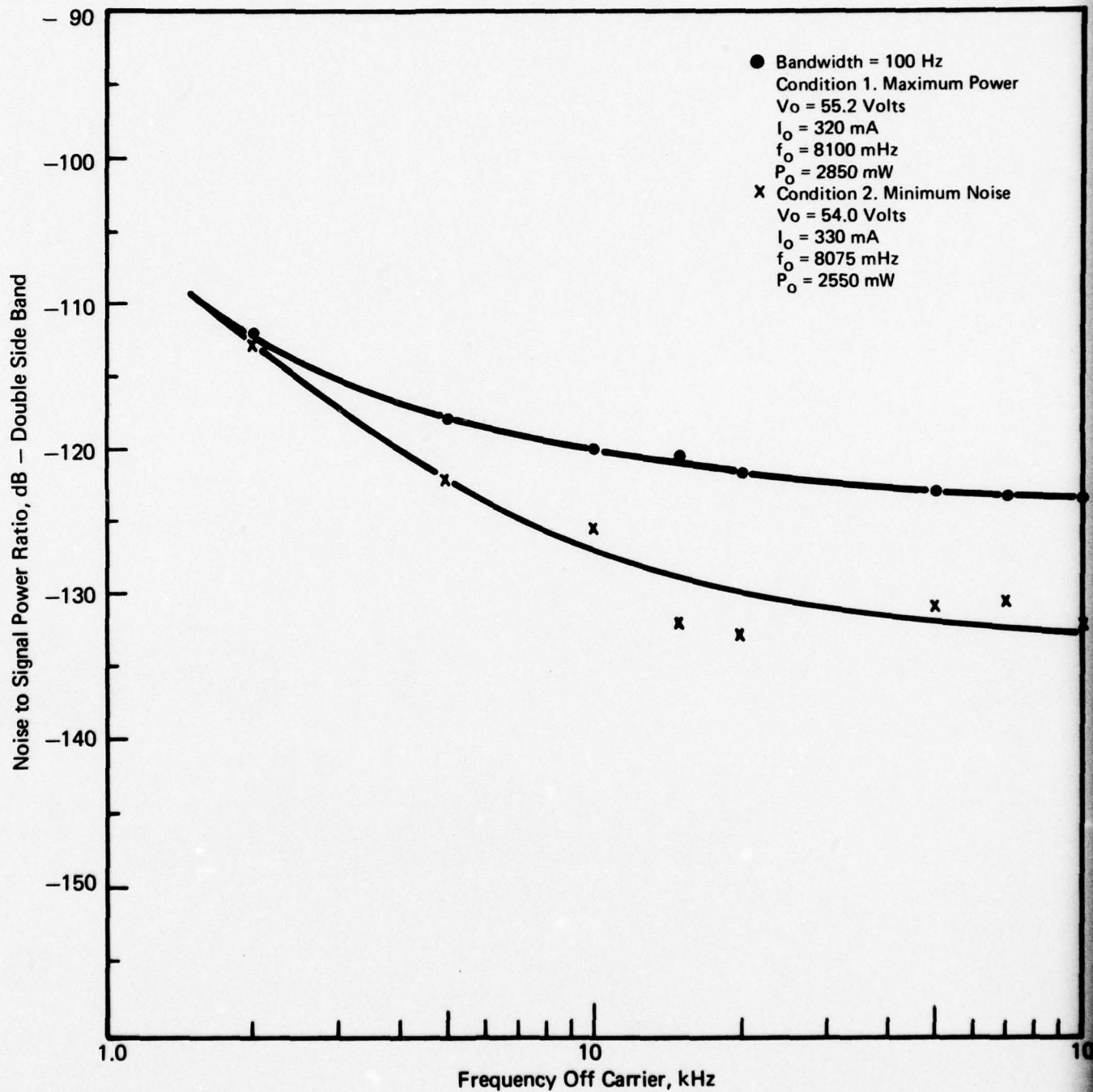

FIGURE 13 AM NOISE VERSUS FREQUENCY OFF CARRIER, FIRST ENGINEERING SAMPLES, DIODE 1

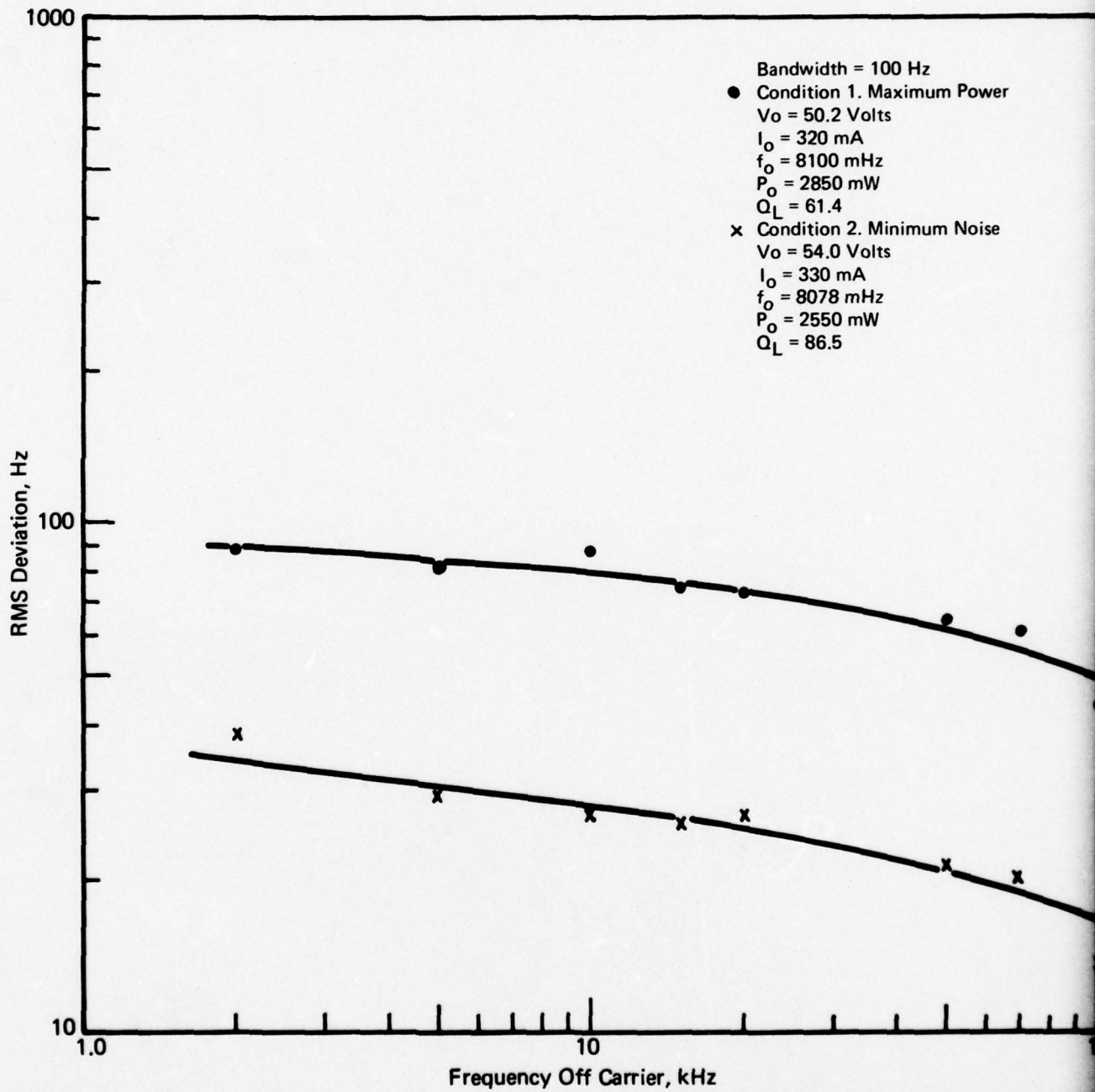

FIGURE 14 FM NOISE VERSUS FREQUENCY OFF CARRIER FIRST ENGINEERING SAMPLES, DIODE 1

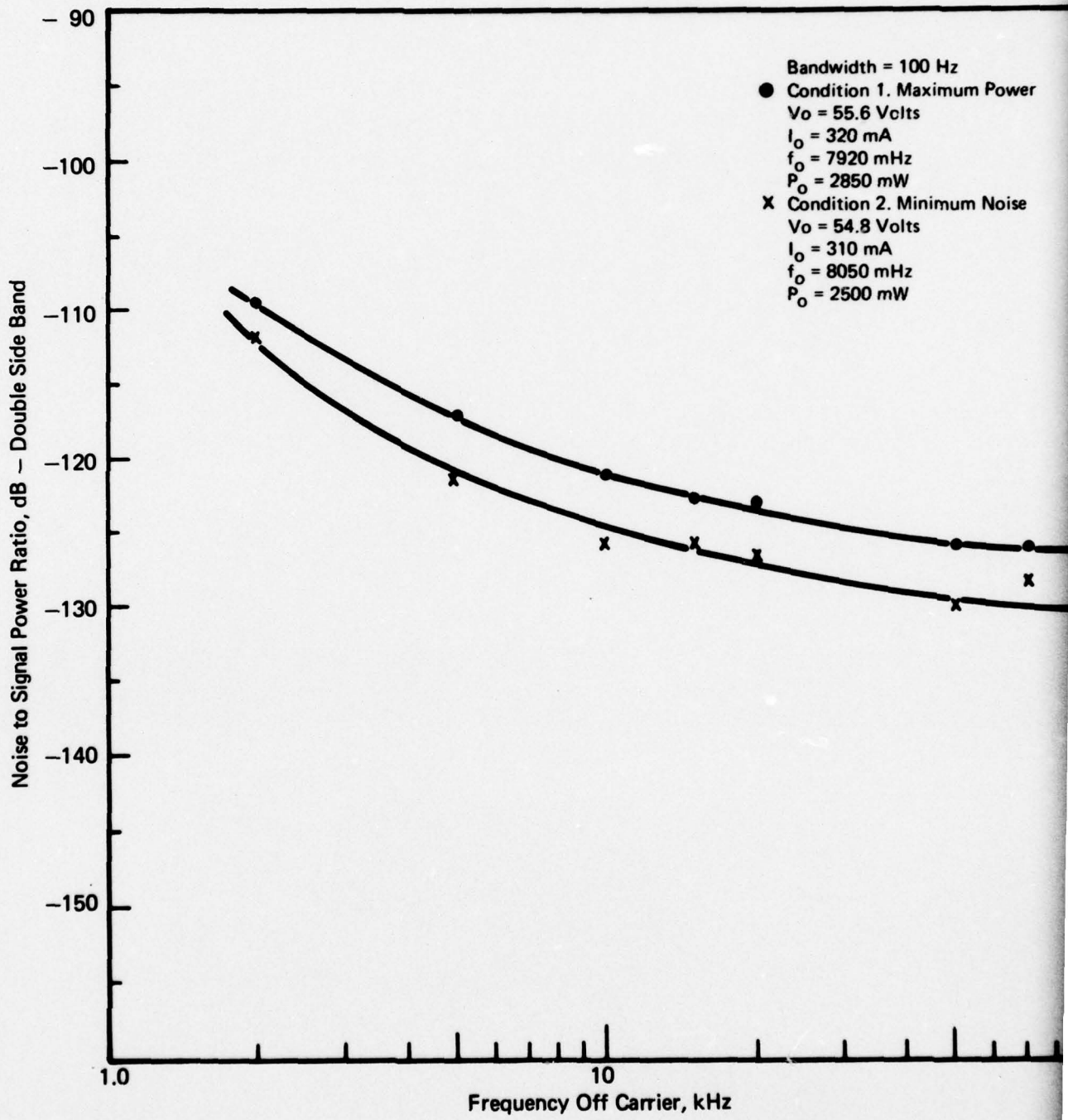

FIGURE 15 AM NOISE VERSUS FREQUENCY OFF CARRIER, FIRST ENGINEERING SAMPLES, DIODE 2

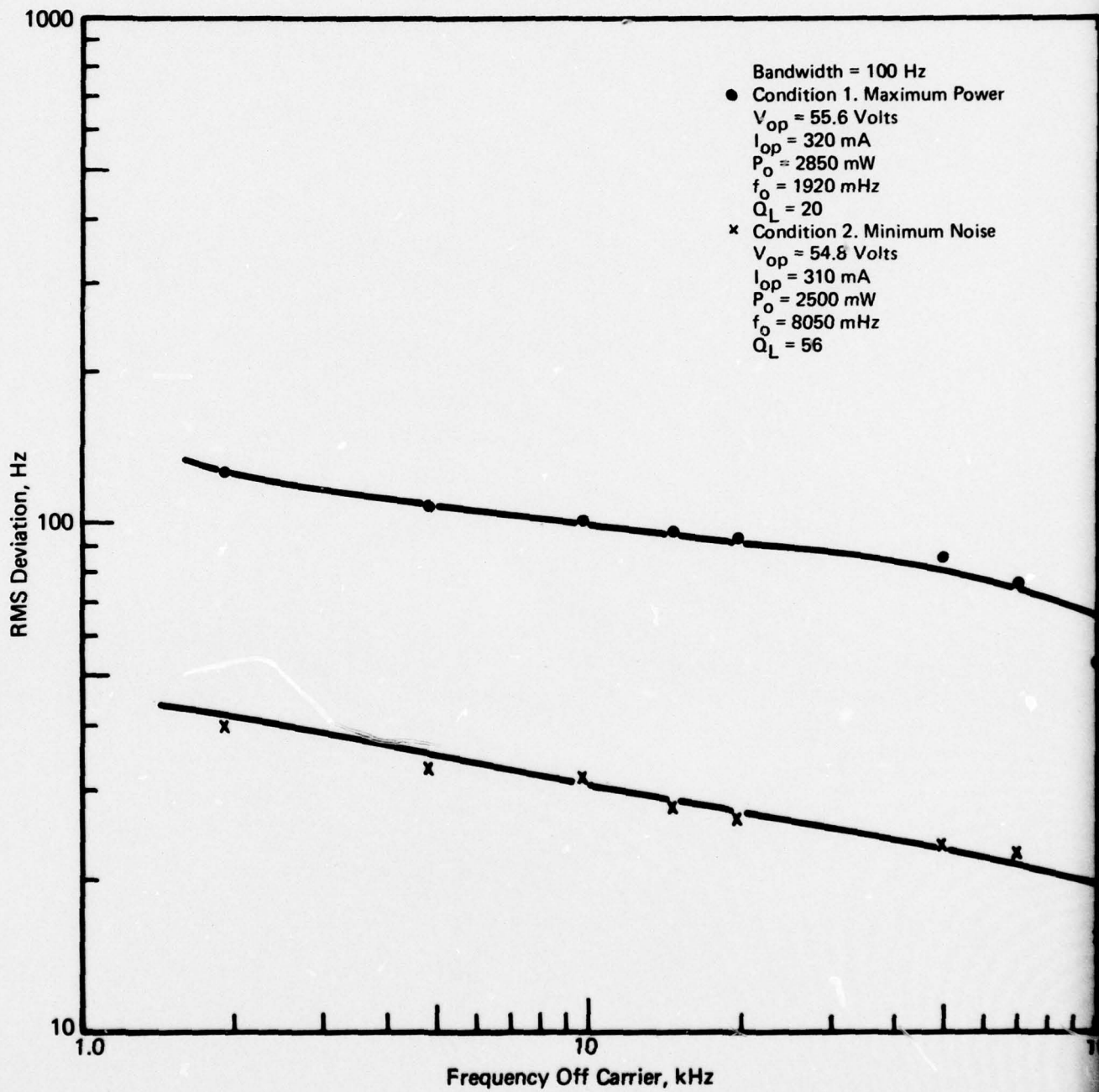

FIGURE 16 FM NOISE VERSUS FREQUENCY OFF CARRIER FIRST ENGINEERING SAMPLES, DIODE 2

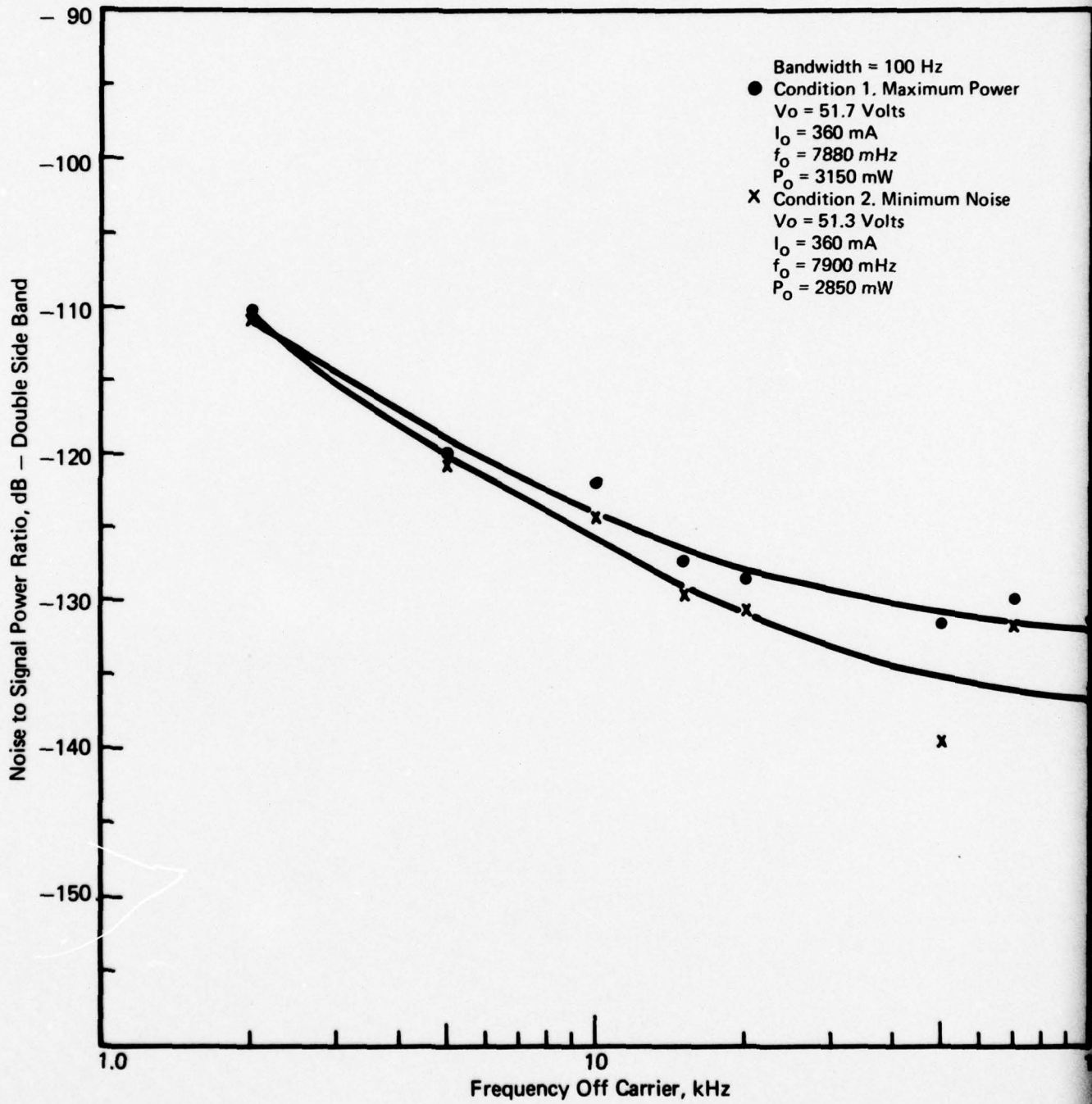

FIGURE 17 AM NOISE VERSUS FREQUENCY OFF CARRIER, FIRST ENGINEERING SAMPLES, DIODE 3

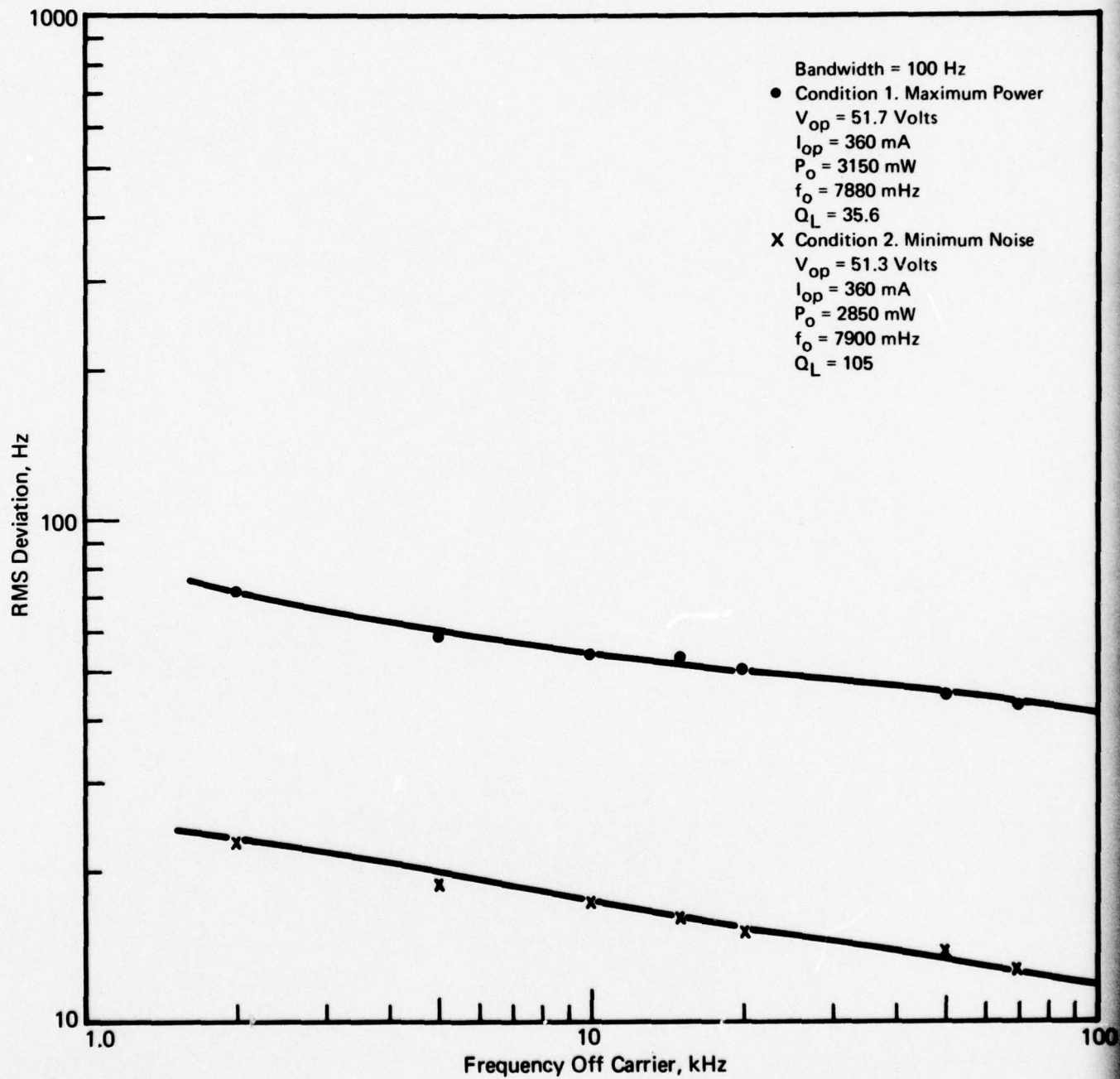

FIGURE 18 FM NOISE VERSUS FREQUENCY OFF CARRIER FIRST ENGINEERING SAMPLES, DIODE 3

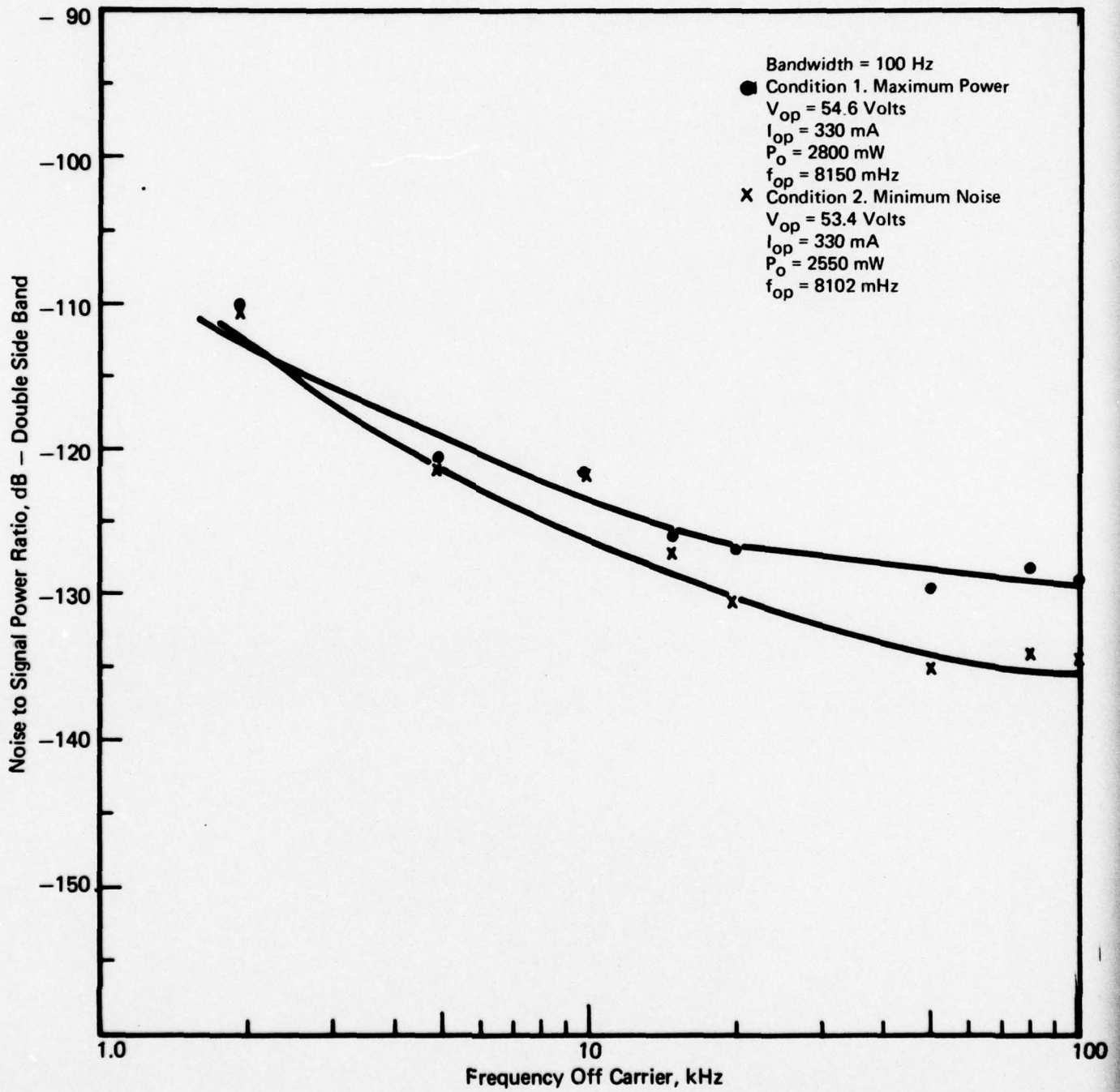

FIGURE 19 AM NOISE VERSUS FREQUENCY OFF CARRIER, FIRST ENGINEERING SAMPLES, DIODE 4

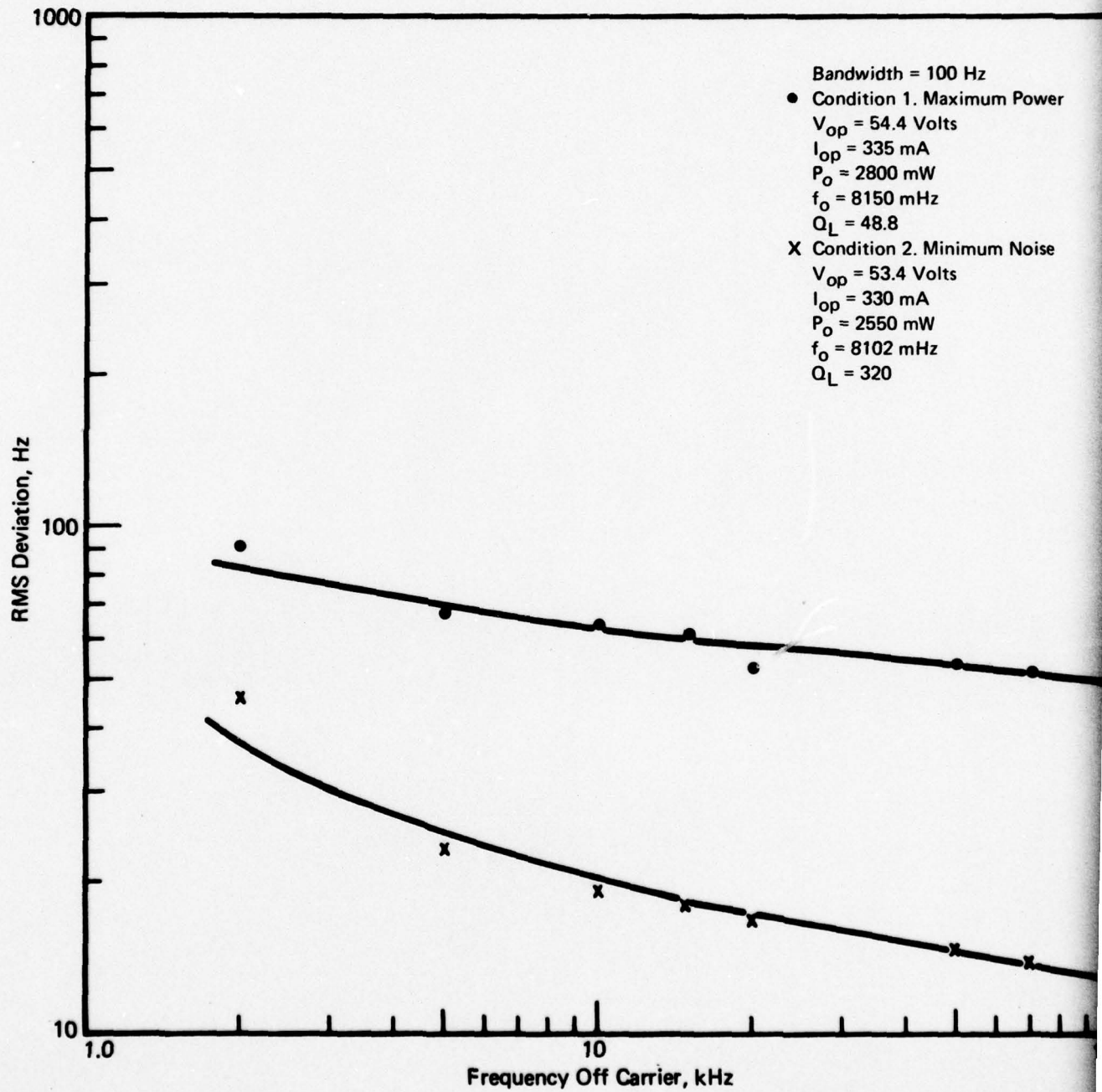

FIGURE 20 FM NOISE VERSUS FREQUENCY OFF CARRIER FIRST ENGINEERING SAMPLES, DIODE 4

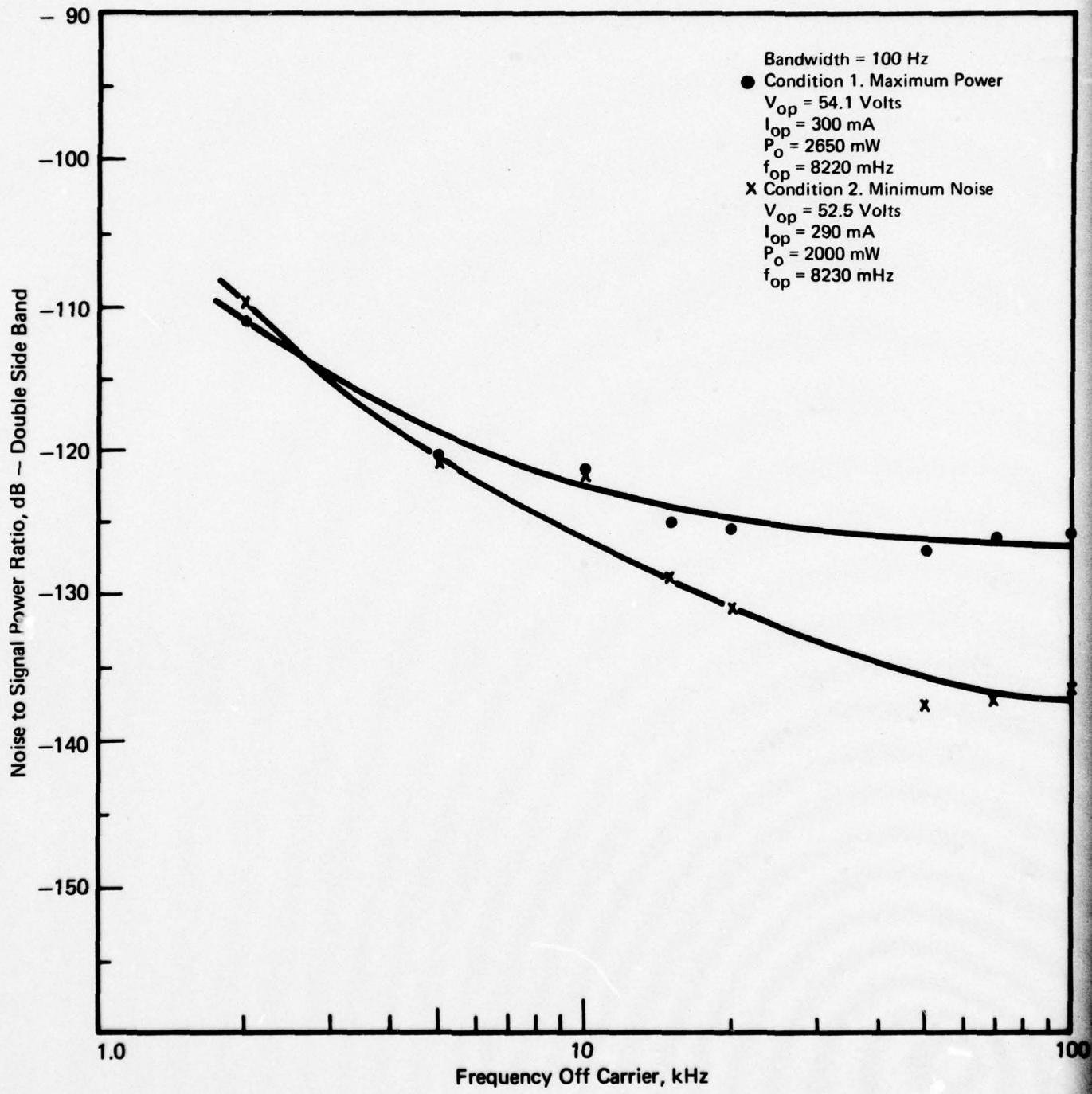

FIGURE 21 AM NOISE VERSUS FREQUENCY OFF CARRIER, FIRST ENGINEERING SAMPLES, DIODE 5

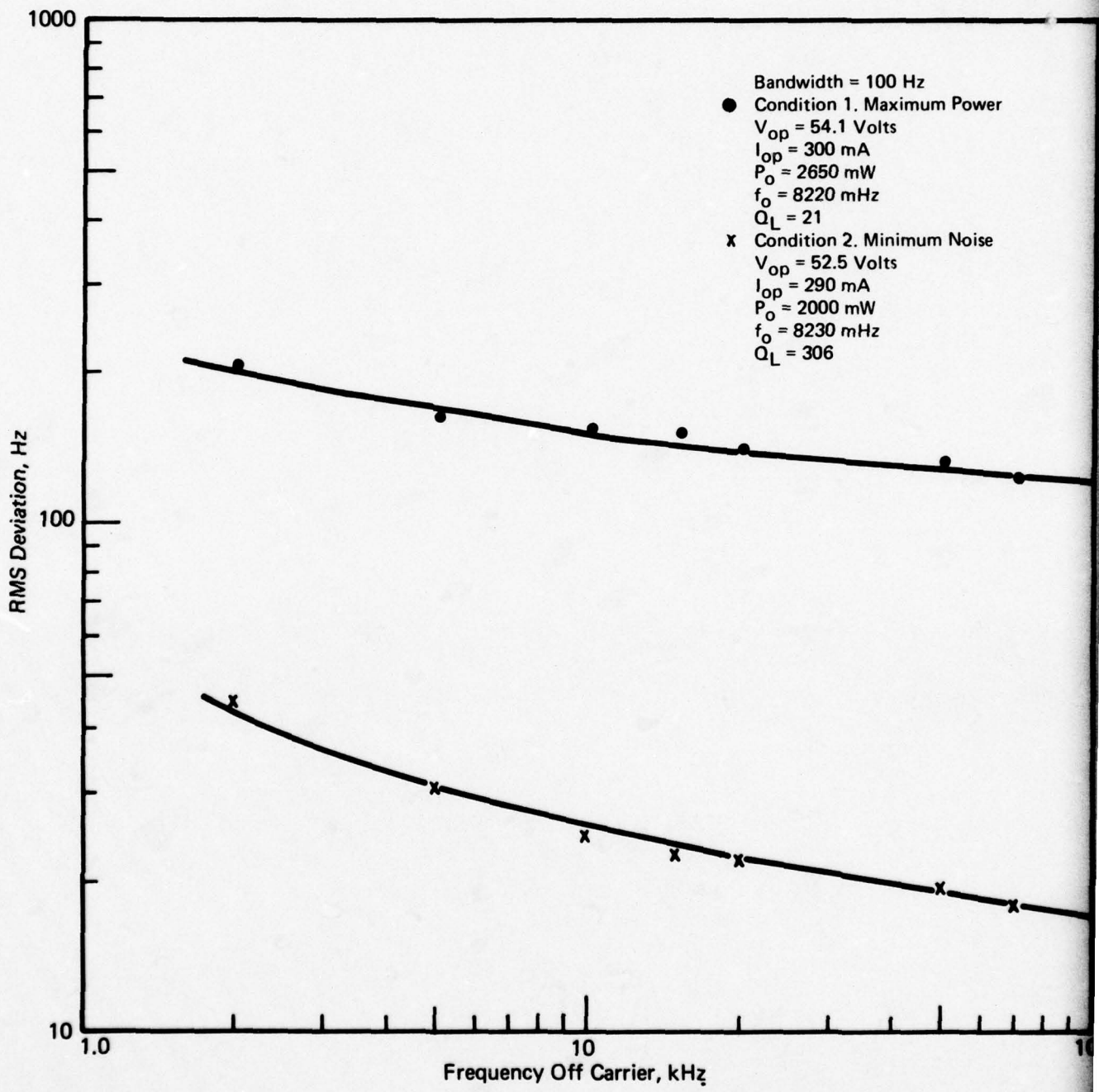

FIGURE 22 FM NOISE VERSUS FREQUENCY OFF CARRIER FIRST ENGINEERING SAMPLES, DIODE 5

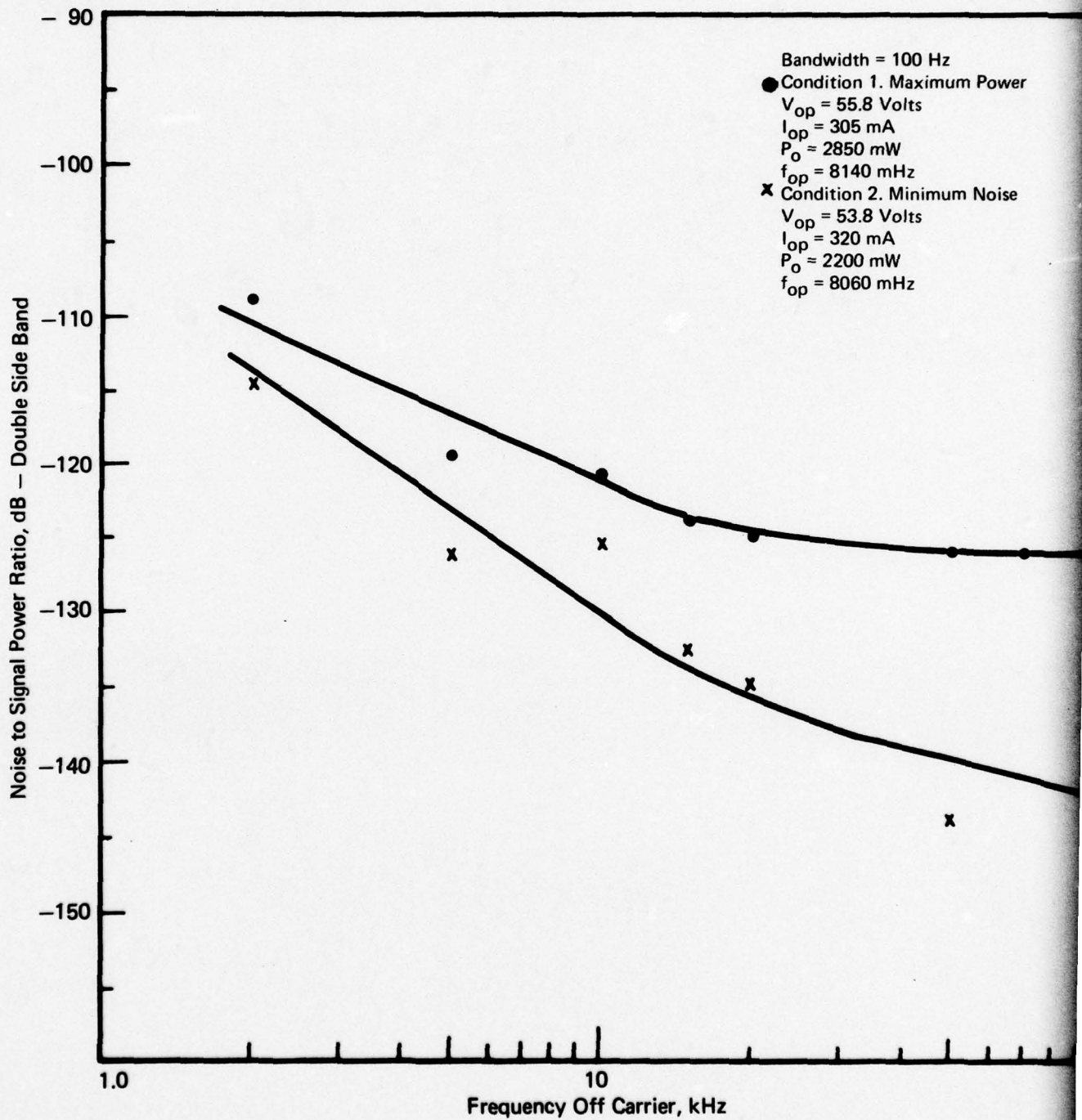

FIGURE 23 AM NOISE VERSUS FREQUENCY OFF CARRIER, FIRST ENGINEERING SAMPLES, DIODE 6

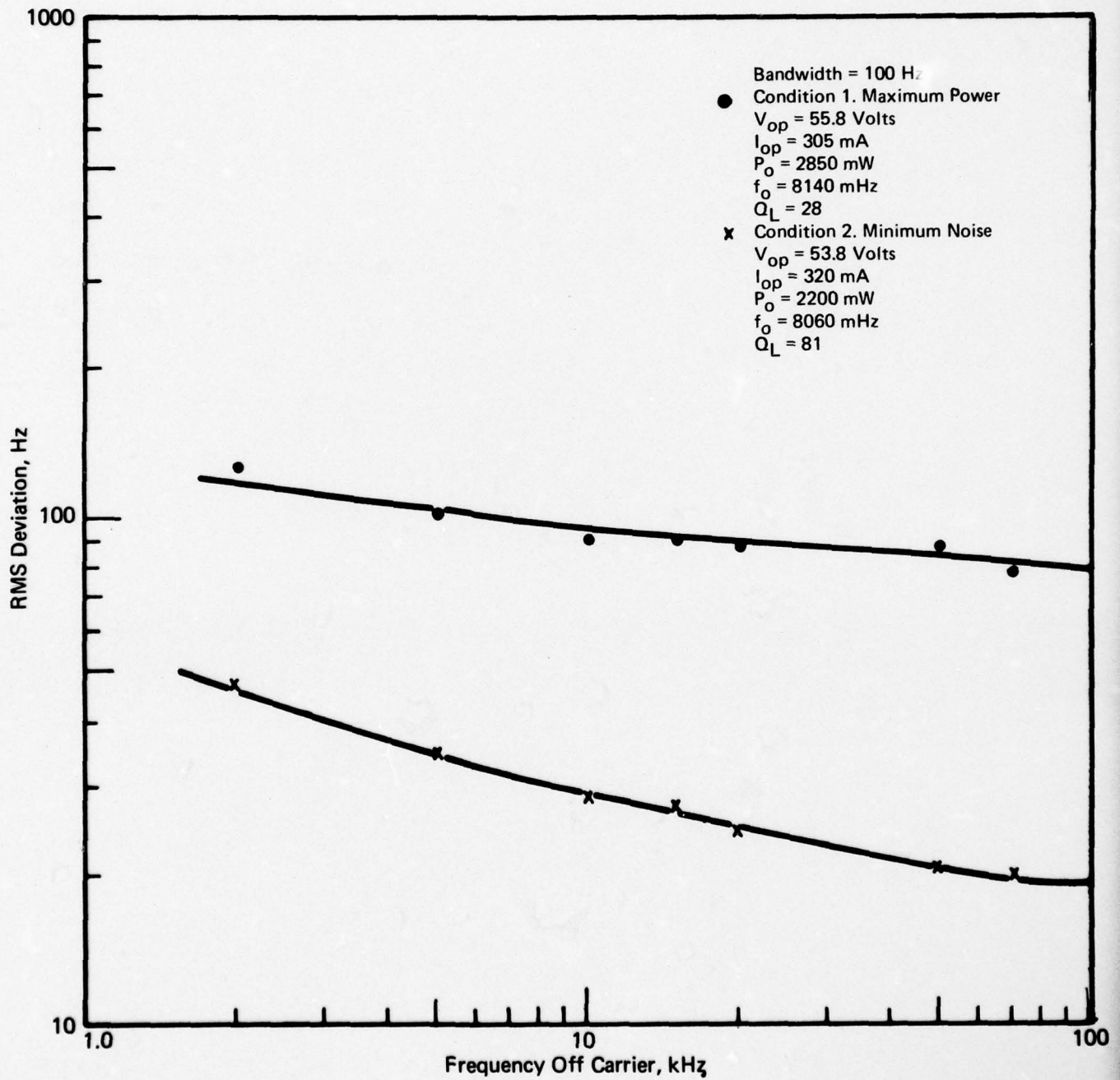

FIGURE 24 FM NOISE VERSUS FREQUENCY OFF CARRIER FIRST ENGINEERING SAMPLES, DIODE 6

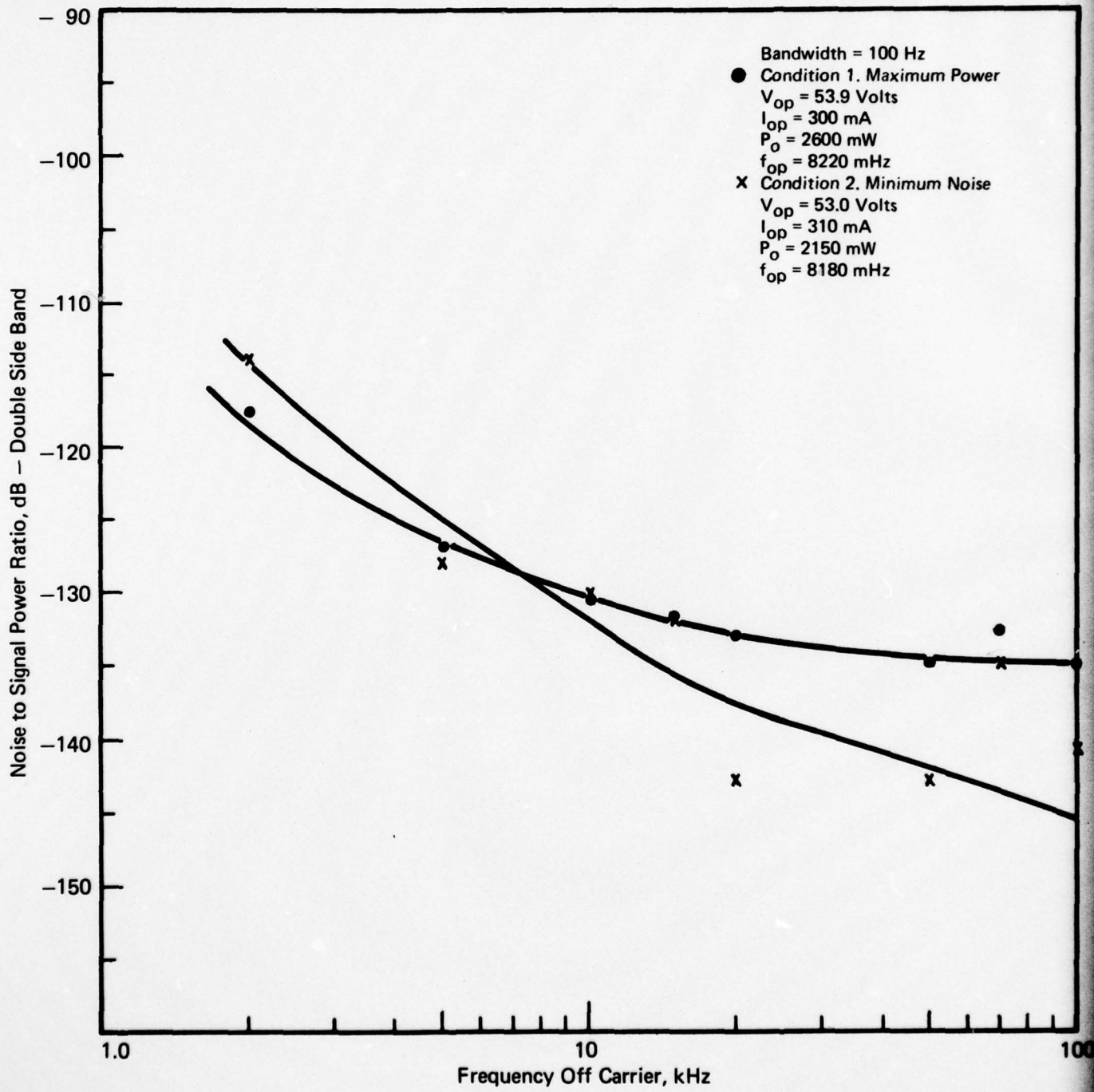

FIGURE 25 AM NOISE VERSUS FREQUENCY OFF CARRIER, FIRST ENGINEERING SAMPLES, DIODE 7

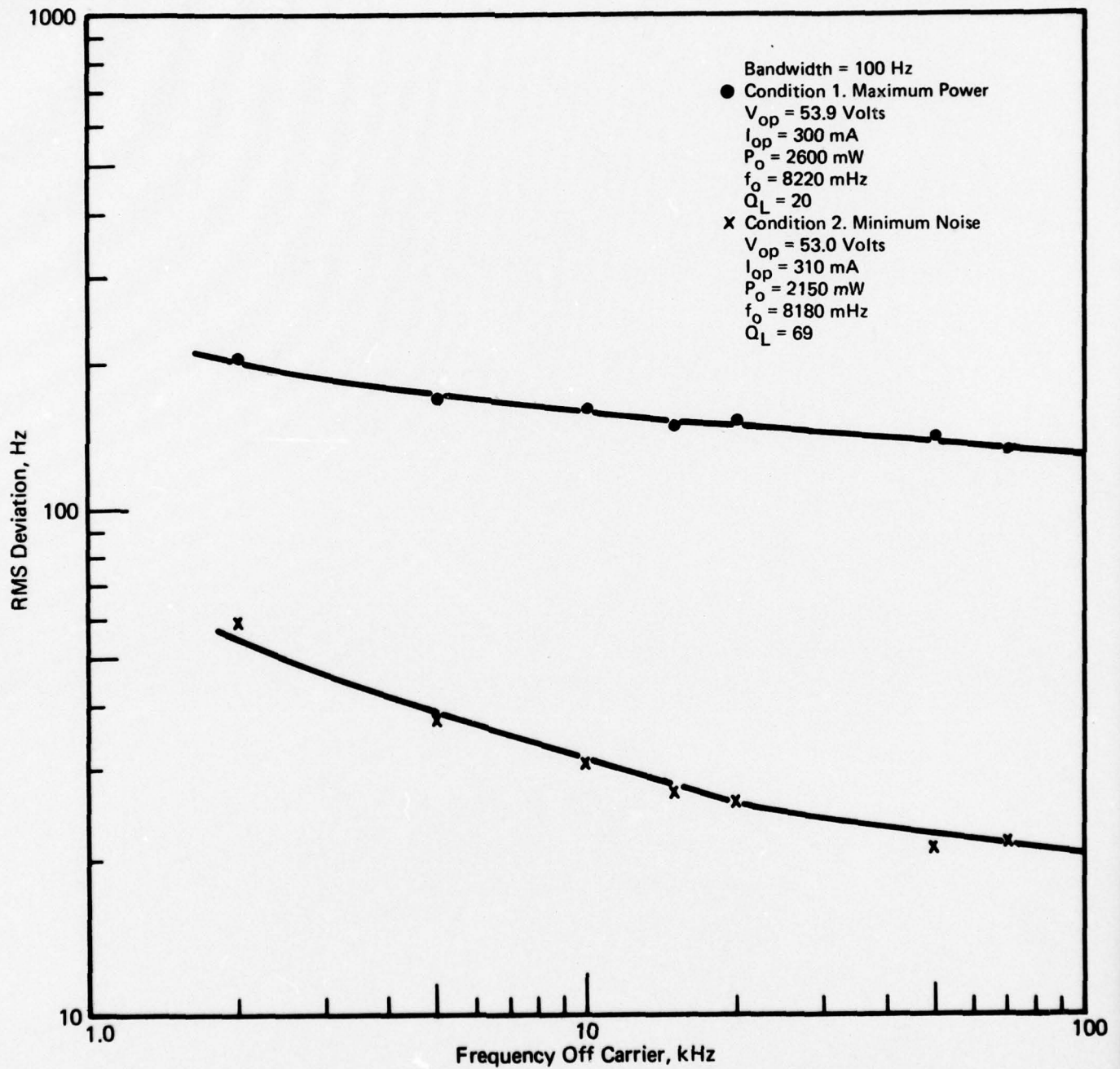

FIGURE 26 FM NOISE VERSUS FREQUENCY OFF CARRIER FIRST ENGINEERING SAMPLES, DIODE 7

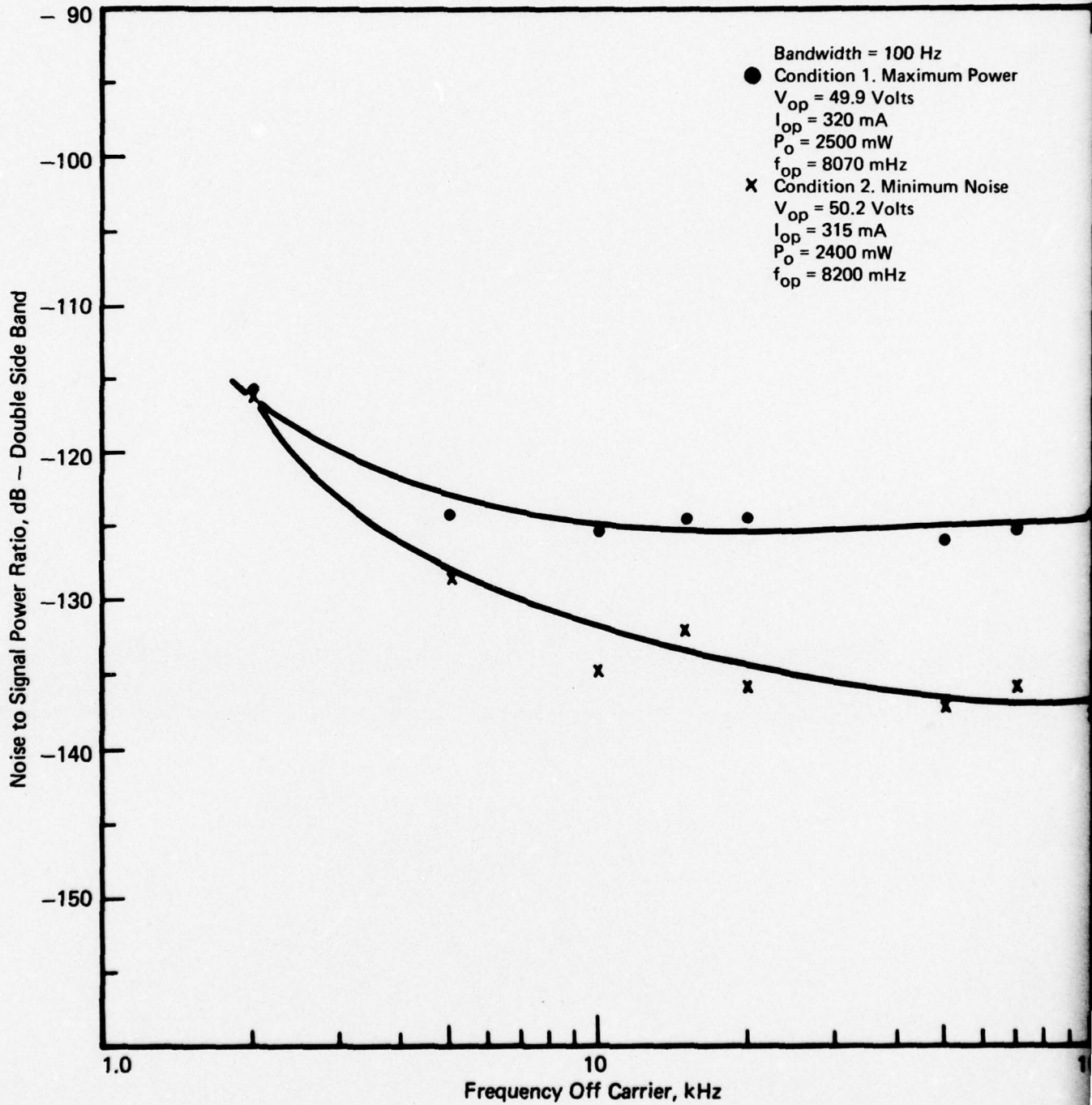

FIGURE 27 AM NOISE VERSUS FREQUENCY OFF CARRIER, FIRST ENGINEERING SAMPLES, DIODE 8

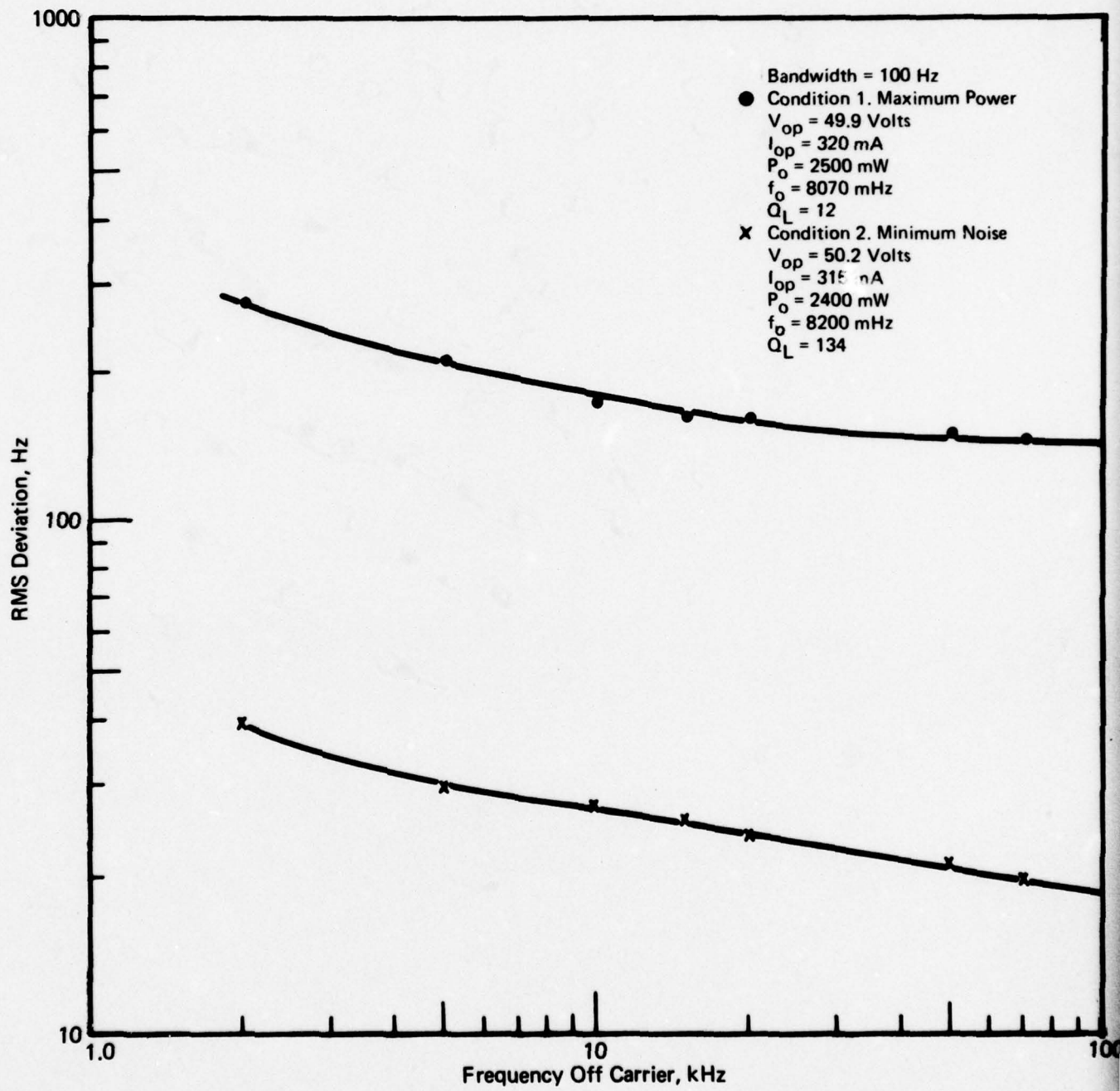

FIGURE 28 FM NOISE VERSUS FREQUENCY OFF CARRIER FIRST ENGINEERING SAMPLES, DIODE 8

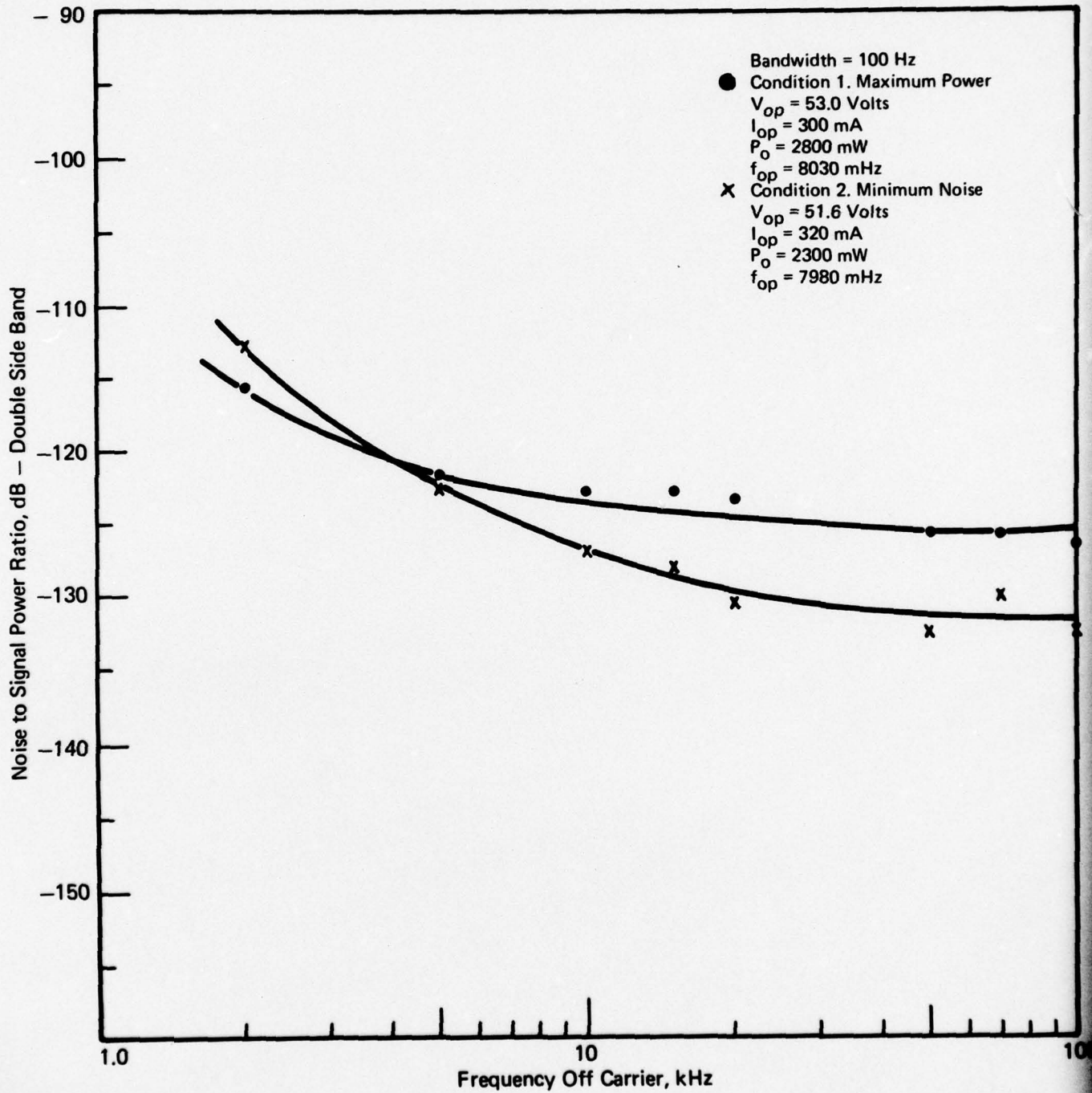

FIGURE 29 AM NOISE VERSUS FREQUENCY OFF CARRIER, FIRST ENGINEERING SAMPLES, DIODE 9

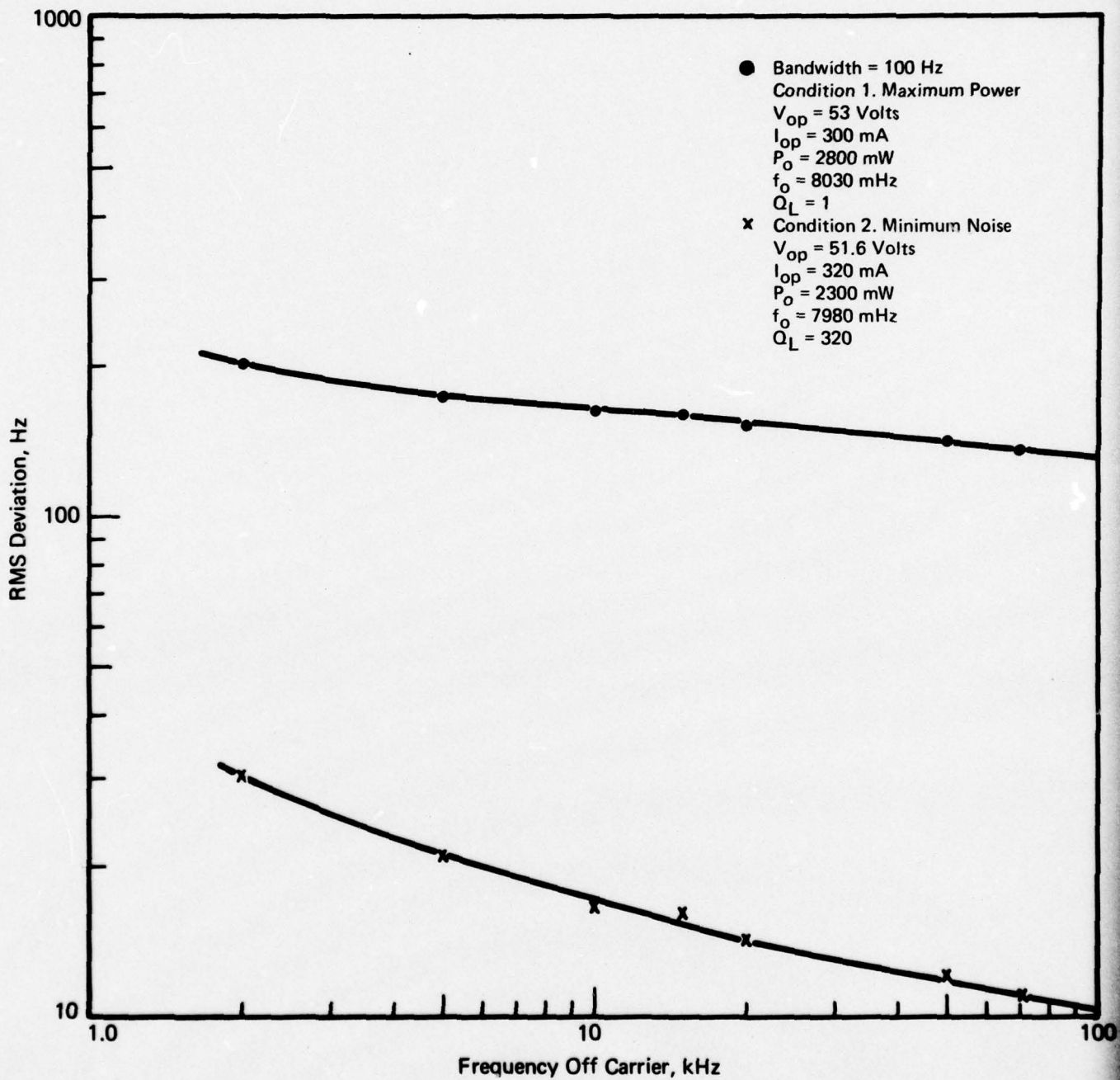

FIGURE 30 FM NOISE VERSUS FREQUENCY OFF CARRIER FIRST ENGINEERING SAMPLES, DIODE 9

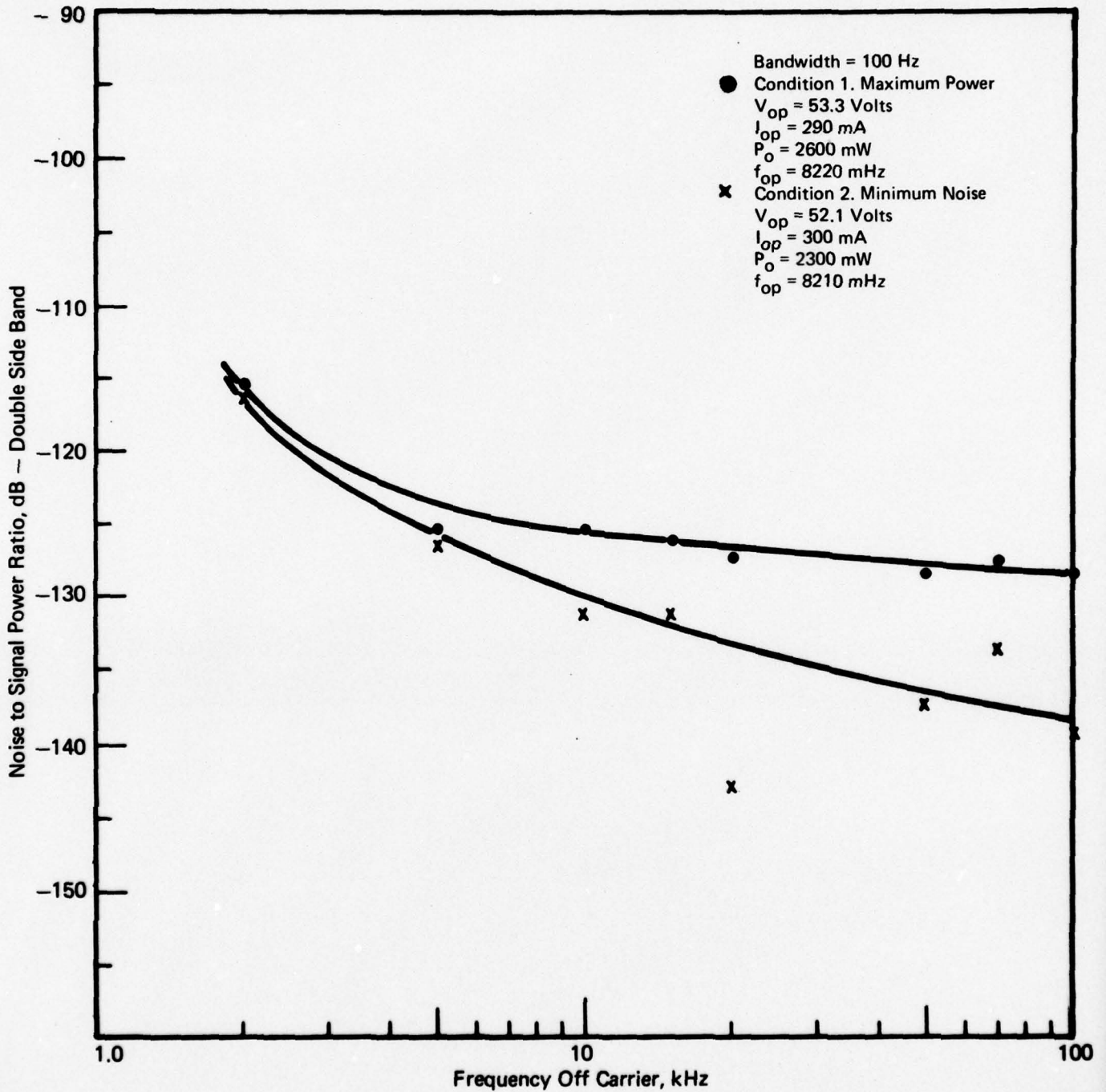

FIGURE 31 AM NOISE VERSUS FREQUENCY OFF CARRIER, FIRST ENGINEERING SAMPLES, DIODE 10

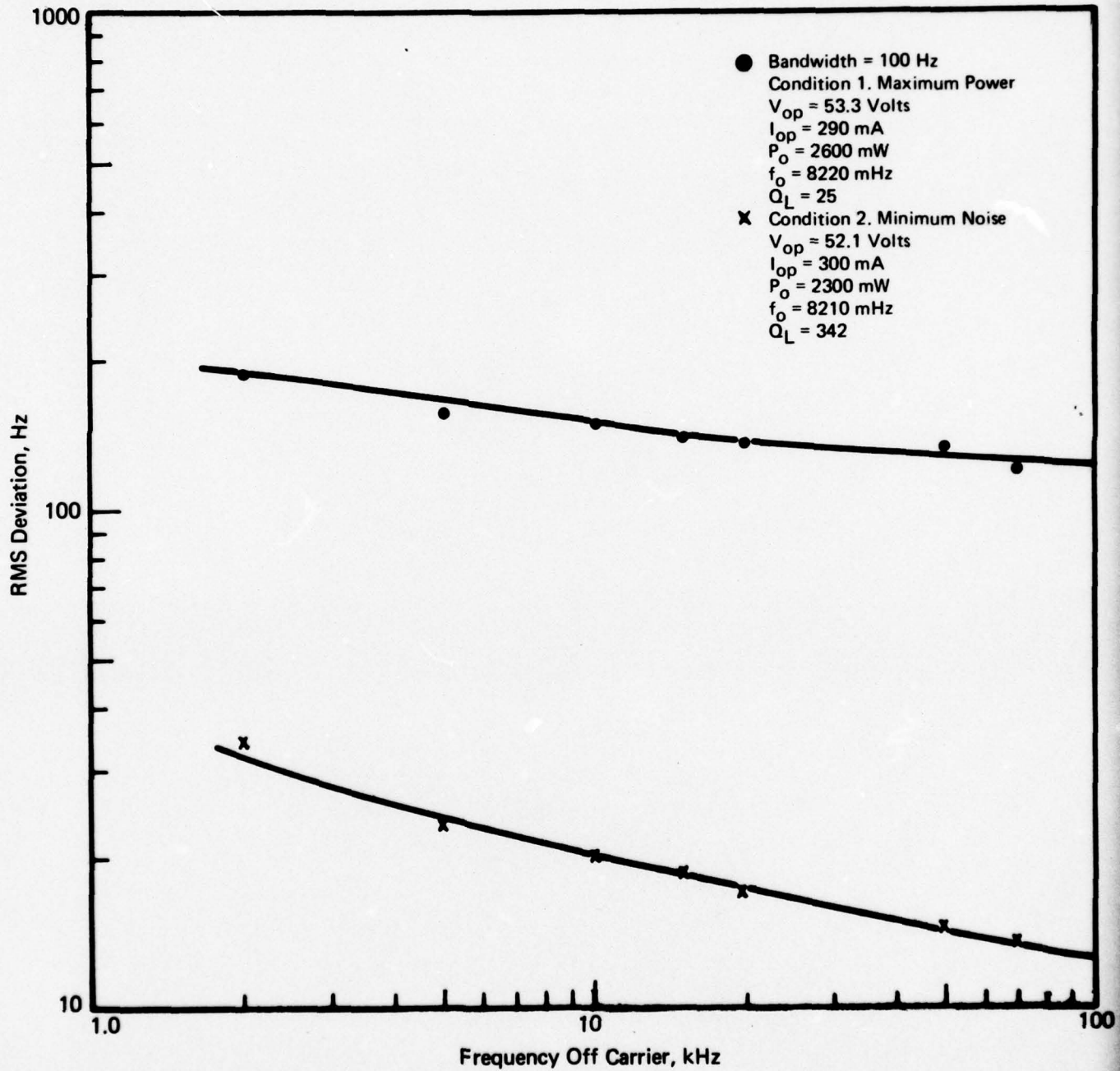

FIGURE 32 FM NOISE VERSUS FREQUENCY OFF CARRIER FIRST ENGINEERING SAMPLES, DIODE 10

as high as 300 were measured after tuning for lowest noise. AM noise was not changed as much by retuning, and was reduced by about 5 dB at 10 KHz off carrier and 12 dB at 100 KHz off carrier. Figures 13 through 32 present noise versus frequency off carrier data for both conditions of maximum power and minimum noise sidebands as observed on a spectrum analyzer.

Steady-state life tests have been initiated involving four devices fabricated at the same time as the engineering samples. These devices were installed in cavities of the type shown in Figure 2 and connected to the apparatus of Figures 5 and 6. The operating conditions at each device are detailed in Table IV. Diode case temperatures fall between 49 to 52°C placing the junctions at 195 to 230°C. Output powers range from 2.0 to 2.55 watts although actual power is somewhat higher because no correction was made for connector and adapter loss. The output of each unit is being continuously monitored using a multipoint chart recorder. Following 750 hours of operation, no failures or changes in output power have occurred.

DEVICE #	POSITION	V _O (Volts)	I _O (mA)	P _O (mW)	T _{CAV} (°C)	T _{CASE} (°C)	θ (°C/W)	T _{JUNC} (°C)	V _{DET} (Arb. Units)	HOURS
1	11	52.1	302	2200	40	52	9.8	195	7.85	750
9	12	54.8	354	2000	38	50	8.7	213	4.29	750
5	13	51.9	298	2550	38	50	10.8	201	4.79	750
6	14	55.5	301	2040	37	49	11.6	230	5.98	750

Table IV. Operating Conditions of Devices on Steady Operating Life Test

V. PROGRAM FOR THE NEXT QUARTER

Since delivery of all of the components for the computer control system have been received, these components will be interfaced and the operational system configuration verified. When this has been accomplished, the remote portions of the computer control system will be relocated from the computer room and wiring of the epitaxial system to the computer control system will be initiated. The wiring will proceed in stages with the gas handling system being the first to be integrated into the computer control components. This will allow the epitaxial system to be returned to operation while the temperature control system wiring is being performed. Preliminary computer programs will be developed which cover the sequence of events which occurs in the gas handling system. The epitaxial reaction system will then be operated.

The epitaxial growth system operating under partial computer control will be used to provide the epitaxial GaAs required for the second engineering samples.

VI. IDENTIFICATION OF PERSONNEL

<u>NAME</u>	<u>TITLE</u>	<u>HOURS</u>
Dr. Robert E. Walline	GaAs Department Manager	56
Dr. John L. Heaton	IMPATT Product Line Manager	34
Mr. James E. Holtz	Materials Engineer	296
Mr. Carl N. Foose	Engineering Assistant	79

REFERENCES

- 1 Murarky, S.P., "High Temperature Stability of Au Pt/n - GaAs Schottky Barrier Diodes", Solid State Electronics, Vol 17, pp. 869, 1974.
- 2 Crosby, M.G., "Carrier and Side-Frequency Relations with Multitone Frequency or Phase Modulation", RCA Review, pp. 103, July, 1938.

HIGH EFFICIENCY, HIGH-POWER GALLIUM
ARSENIDE READ-TYPE IMPATT DIODES

1. SCOPE

1.1 Scope. - This specification covers the detailed requirements for high efficiency, high power Gallium Arsenide Read-Type IMPATT Diodes.

2. APPLICABLE DOCUMENTS

2.1 The following documents, of the issue in effect on the date of invitation for bids or request for proposal, form a part of the specification to the extent specified herein.

SPECIFICATIONS

MILITARY

MIL-S-19500 Semiconductor Devices, General Specification for.

STANDARDS

MILITARY

MIL-STD-750 Test Methods for Semiconductor Devices

MIL-STD-1311 Test Methods for Electron Tubes

(Copies of specification, standards, drawings and publications required by suppliers in connection with specific procurement functions should be obtained from the procuring activity or as directed by the Contracting Officer).

3. REQUIREMENTS

3.1 Detail requirements. - The individual item requirements shall be in accordance with MIL-S-19500, and as specified herein. In the event of any conflict, the requirements of this specification shall govern.

BEST AVAILABLE COPY

SCS-481

3.2 Abbreviations and symbols. - The abbreviations and symbols used herein are defined in MIL-S-19500 and as follows:

Q_{ext} = external quality factor of diode oscillator

3.3 Design and construction and physical dimensions. - The diodes shall be made by epitaxial growth of Read-type profiles. The diode shall consist of a single mesa, single chip mounted in a ceramic-to-metal microwave package. The package shall be gold plated and hermetically sealed. The package shall provide means for readily heat sinking the diode. A schematic of a suitable package is shown in Figure 1.

3.3.1 Operating position. - The diode shall be capable of proper operation in any position.

3.4 Performance characteristics. - The diode performance characteristics, while operating as oscillators, shall be as specified in Tables I and II and as listed below. The performance characteristics shall apply over the specified ambient operating temperature range unless otherwise specified.

3.4.1 Process conditioning. - All units shall be process conditioned before they are subjected to the tests and examinations defined in Tables I and II (see 4.5.4).

3.5 Serial number. - The manufacturer shall assign a serial number to each device furnished to this specification. This serial number shall be sequential and non-repeating.

3.6 Interchangeability. - All parts having the same manufacturer's part number shall be directly and completely interchangeable with each other with respect to installation and performance within the requirements of this specification.

3.7 Storage life (non-operating). - Following storage at an ambient temperature of $200^{\circ}\text{C} \pm 3^{\circ}\text{C}$ for 1000 hours minimum, all diodes shall meet the requirements of oscillator frequency, oscillator output power and oscillator efficiency as defined in Table III (see 4.6.5).

3.8 Operating life. - All diodes which have operated for 1000 hours minimum per the requirements of Table III shall have a power output of no less than 75 percent of the initial power output (see 4.6.6).

BEST AVAILABLE COPY

3.9 Mechanical tuning. - The RF output power shall not decrease below specified value in Table III. The frequency and power shall vary smoothly with no steps or jumps (see 4.6.3).

3.10 External Q. - The external quality factor, Q_{ext} , of the diode oscillator shall not be more than 200 (see 4.6.4).

4. QUALITY ASSURANCE PROVISIONS

4.1 Responsibility for inspection. - The contractor is responsible for the performance of all inspections specified herein. The contractor may utilize his own facilities or any commercial laboratory acceptable to the Government. Inspection records of the examinations and tests shall be kept complete and available to the Government as specified in the contract. The Government reserves the right to perform any of the inspections set forth in the specification where such inspections are deemed necessary to assure that supplies and services conform to prescribed requirements.

4.2 Classification of inspection. - Inspection shall be classified as follows:

(a) First article inspection (does not include preparation for delivery) (see 4.4).

(b) Quality conformance inspection (see 4.5).

4.3 Test plan. - The contractor prepared Government-approved test plan shall contain:

(a) Time schedule and sequence of examinations and tests.

(b) A description of the method of test and procedures.

(c) Programs of any automatic tests including flow charts and block diagrams.

(d) Identification and brief description of each inspection instrument and date of most recent calibration.

4.4 First article inspection. - First article testing shall consist of the tests specified in Tables I and II. For the tests of Table I and the end point measurements of Table II, the diodes shall be operating as oscillators in the test cavity. The number of units to be subjected to each test shall be as stated in the contract. No failures will be permitted.

BEST AVAILABLE COPY

4.5 Quality conformance inspection. - This inspection shall be performed on samples selected from the pilot production as specified in the contract and shall consist of Group A and B inspections.

4.5.1 Group A inspection. - Group A inspection shall consist of the examinations and tests specified in Table I. The diodes shall be operating as oscillators in the test cavity.

4.5.2 Group B inspection. - Group B inspection shall consist of the examinations and tests specified in Table II.

4.5.3 Group C inspection. - Group C inspections are not applicable to this specification.

4.5.4 Process conditioning. - All diodes will be stored, non-operating, under the following conditions:

(a) Junction temperature: 225°C max
200°C min

(b) Storage time: 168 hrs. min

4.5.5 Test cavity. - Two suitable microwave test cavities, one for each frequency band, shall be used to test the performance of the diodes.

4.6 Methods of examination and test. - Methods of examination and test shall be as specified in Tables I and II and as follows:

4.6.1 AM noise. - An AM noise measurement system as shown schematically in Figure 2 shall be used to determine the AM noise to signal ratio. The AM noise spectrum shall be measured continuously from 10 KHz to 100 KHz from the carrier as a minimum and recorded by an x-y recorder. Noise measurements shall be performed while diode oscillator is meeting the operating requirements in Table III.

4.6.2 FM noise. - An FM noise measurement system as shown schematically in Figure 2 shall be used to determine FM noise deviation. The FM noise spectrum shall be measured continuously from 10 KHz to 100 KHz from the carrier as a minimum and recorded by an x-y recorder. Noise measurement shall be performed while the diode oscillator is meeting the operating requirements in Table III.

4.6.3 Mechanical tuning. - The oscillator unit will be mechanically tuned over the required frequency range of ± 250 KHz from operating frequency.

BEST AVAILABLE COPY

4.6.4 External Q. - The external quality factor, Q_{ext} , of the diode oscillator shall be determined by standard injection locking techniques. A small locking signal shall be injected into the diode oscillator for measurement of locking bandwidth as a function of injected power.

4.6.5 Storage life (non-operating). - The diodes shall be stored at an ambient temperature of $200^{\circ}\text{C} \pm 3^{\circ}\text{C}$ for 1000 hours minimum. These diodes shall be selected randomly from diodes which have undergone process conditioning and have successfully passed all Group A inspections. Upon completion of storage, the diodes shall be subjected to the following tests described in Table I: Oscillator frequency, oscillator output power and efficiency.

4.6.6 Operating life. - The diodes shall be tested under operating conditions in accordance with Table III for 1000 hours minimum. Power output shall be monitored continuously. The diodes subjected to the operating life test shall be selected randomly from diodes which have undergone process conditioning and have successfully passed all Group A inspections. The number of failures as a function of time shall be recorded. The test shall be conducted in an ambient temperature of $25 \pm 3^{\circ}\text{C}$ and the cavity temperature shall not exceed 75°C during this test.

4.6.7 Efficiency (RF-DC). - The RF to DC power efficiency of diodes operating as oscillators shall be determined by measuring the DC input power and using standard mathematical formulations.

$$\text{Power Efficiency (RF-DC)} = \frac{\text{Power output (RF)}}{\text{Power in (DC)}} \times 100$$

4.6.8 RF output power. - RF output power of diodes operating as oscillators shall be measured at operating frequency in accordance with method 4250, MIL-STD-1311 using a calibrated thermistor and power meter.

4.6.9 Oscillator frequency. - Frequency of diodes operating as oscillators shall be determined with a calibrated spectrum analyzer and verified with a calibrated frequency meter.

4.6.10 DC bias voltage. - DC bias voltage of diodes operating as oscillators shall be measured in accordance with method 4016, MIL-STD-750.

4.6.11 DC bias current. - DC bias current of diodes operating as oscillators shall be measured in accordance with method 4016, MIL-STD-750.

SCS-481

4.6.12 Nuclear radiation exposure. - Devices will be exposed to the neutron level specified below over a time period not to exceed five (5) minutes. This exposure will be conducted with the devices in a non-operating, non-biased condition and at a temperature not to exceed 40°C. Devices shall not experience temperatures in excess of 40°C prior to evaluation testing. Evaluation will be conducted in such a manner that no device will be operated for more than two (2) minutes prior to completion of the sub-group tests. These precautions are necessary to reduce the effects of high temperature annealing of the radiation induced damage.

$10^{13}n/cm^2$, 1 MeV equivalent (Si)

10^4 rads (Si) gamma

4.6.13 Junction temperature. - The junction temperature shall be determined as follows: The breakdown voltage of the diode shall be measured at 40°C intervals between 20°C and 200°C in accordance with method 4021 of MIL-STD-750. The breakdown voltage shall be that voltage corresponding to a reverse current of 1 mA. The diode shall then be biased under pulsed conditions in a lossy circuit to suppress oscillations thus making input power equivalent to dissipated power. Pulse width shall be sufficient (about 1 msec) for the diode to reach thermal equilibrium. The diode shall then be pulsed down to a current of 1 mA and breakdown voltage shall be measured. The pulse-down duration shall be short (several microseconds) to prevent cooling of the diode. From this data thermal resistance of the diode shall be determined. The junction temperature of a diode under operating conditions shall be determined from its power input, power output and thermal resistance.

5. PREPARATION FOR DELIVERY

5.1 Preparation for delivery. - Packaging and marking shall be in accordance with the contract.

6. NOTES - None.

BEST AVAILABLE COPY

TABLE I - GROUP A INSPECTION

 $T_A = 25 \pm 3^\circ\text{C}$ unless otherwise specified

Test	Method	Symbol	Min	Max	Units
<u>Subgroup 1</u>					
Oscillator Frequency	4.6.9	f_o			
Diode Type 1			9	11	GHz
Diode Type 2			14	16	GHz
Oscillator output power	4.6.8	P_o			
Diode Type 1			3.5		W-CW
Diode Type 2			2.5		W-CW
Oscillator efficiency (RF-DC)	4.6.7	η	20		%
Junction Temp	4.6.13	T_j		200	$^\circ\text{C}$
<u>Subgroup 2</u>					
Mechanical tuning	4.6.3	Δf_{mech}	± 250		MHz
<u>Subgroup 3</u>					
AM Noise	4.6.1	(N/S) _{AM}		-115	dB
FM Noise	4.6.2	Δf_{rms}		50	Hz
<u>Subgroup 4</u>					
DC Bias voltage	4.6.10	V_o		70	v
DC Bias current	4.6.11	I_o		500	ma
<u>Subgroup 5</u>					
External Q	4.6.4	Q_{ext}		200	

BEST AVAILABLE COPY

TABLE II GROUP B INSPECTION

Test	MIL-STD-750 Method	Details	Min	Max	Units
<u>Subgroup 1</u> Shock	2016	Non-operating; 500G, t = 1.0 msec, X ₁ , Y ₁ , and Z ₁ orientation			
Vibration, Variable Freq.	2056	Non-operating; 20G, 50 to 2000 Hz.			
Constant acceleration	2006	Non-operating; 20,000G min, X ₁ , Y ₁ and Z ₁ orientation			
Hermeticity	1071	Test Condition H- Traces Gas Fine Leak (Helium)			
End point measurements; Table I, Subgroup 1					
<u>Subgroup 2</u> Nuclear radiation exposure	4.6.12				
End point measurements: Table I, Subgroup 1					
<u>Subgroup 3</u> Storage life (non-operating)	4.6.5				
<u>Subgroup 4</u> Operating life	4.6.6				

BEST AVAILABLE COPY

TABLE III OPERATING REQUIREMENTS

Ambient Temperature Range: -40°C to 65°C

Diode Type 1

Oscillator frequency	$10.0\text{ GHz} \pm 1.0\text{ GHz}$
Oscillator output power	3.5 W-CW, min.
Oscillator efficiency (RF-DC)	20% min
Junction Temperature	200°C max

Diode Type 2

Oscillator frequency	$15.0\text{ GHz} \pm 1.0\text{ GHz}$
Oscillator output power	2.5 W-CW, min
Oscillator efficiency (RF-DC)	20% min
Junction Temperature	200°C max

BEST AVAILABLE COPY

SCS-481

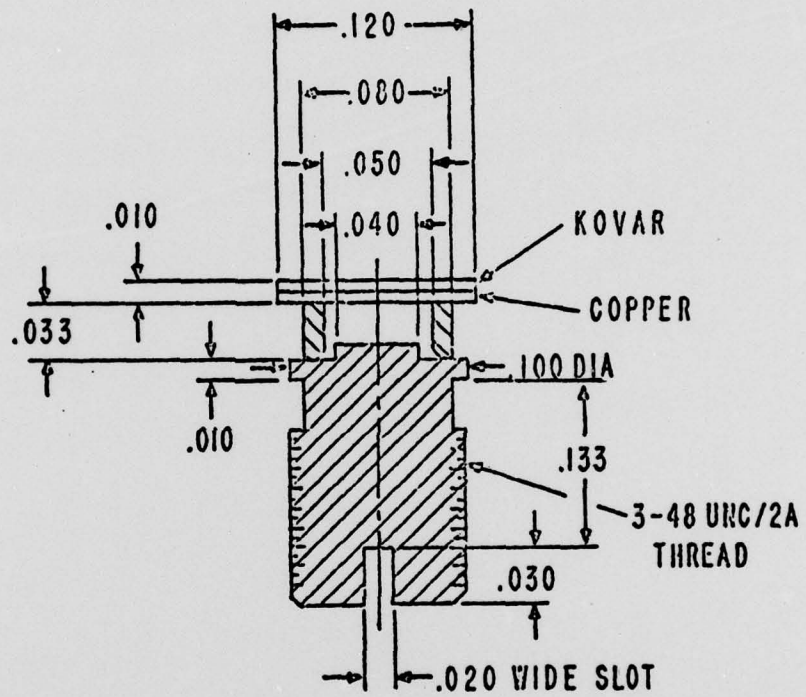

FIGURE 1

CERAMIC-TO-METAL MICROWAVE DIODE PACKAGE

BEST AVAILABLE COPY

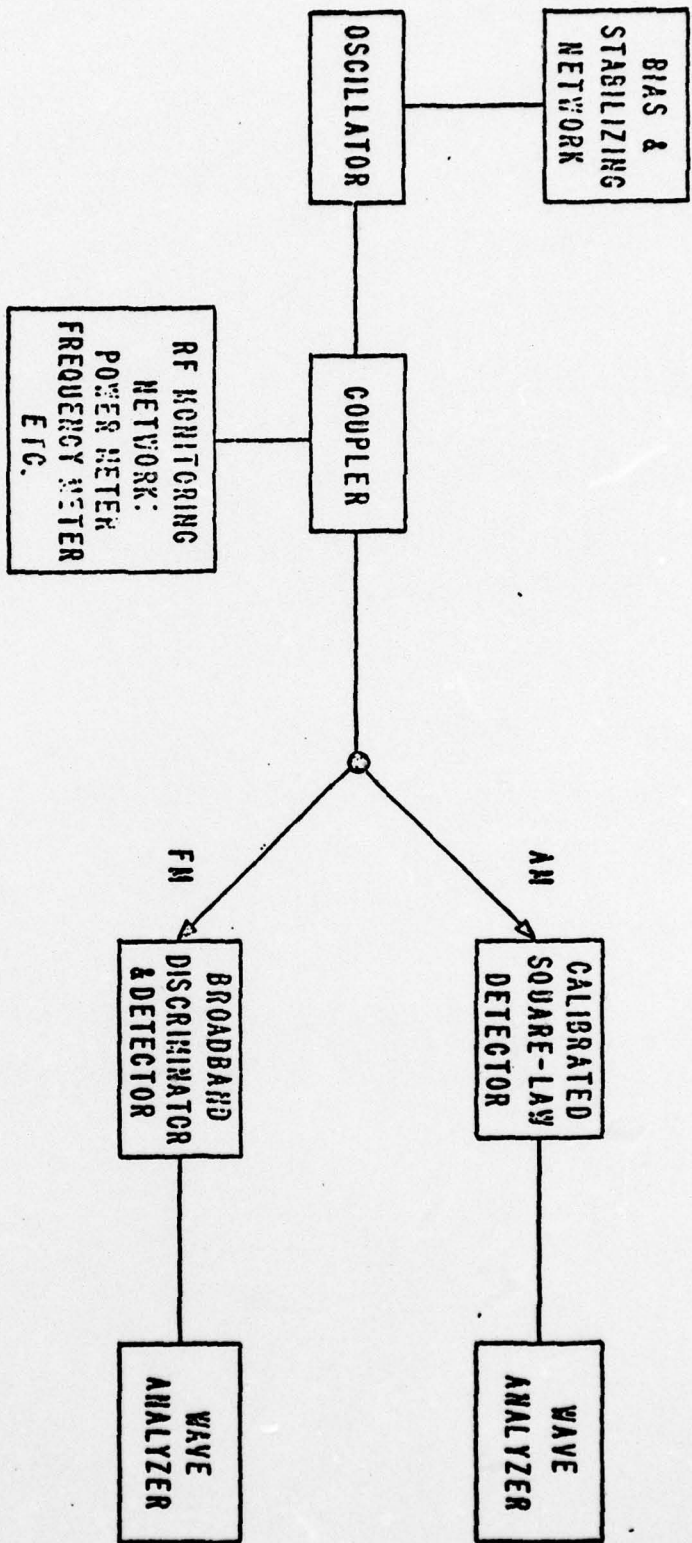

FIGURE 2
AM & FM NOISE MEASUREMENT SYSTEM (SCHEMATIC)

DISTRIBUTION LIST

	<u>#</u> <u>CY</u>		<u>#</u> <u>CY</u>
Commander Rome Air Development Center Griffiss Air Force Base ATTN: (EMERR) Mr. L. Gubbins Rome, New York 13440	1	Commander Rome Air Development Center Griffiss Air Force Base ATTN: (EMERR) Mr. Regis C. Hilow Rome, New York 13440	1
Commander Air Force Materials Laboratory ATTN: MATE (Ms. E. Torrance) Electronic Branch Wright-Patterson Air Force Base Dayton, Ohio 45433	1	AFAL (AVTA) Electronic Technology Division ATTN: Mr. Robert D. Larson, Chief Advanced Electronics Devices Branch Wright-Patterson Air Force Base Dayton, Ohio 45433	1
Advisory Group on Electron Devices 201 Varick Street, 9th Floor New York, New York 10014	2	National Aeronautics & Space Administration George C. Marshall Space Flight Center ATTN: R-QUAL-FP (Mr. Leon C. Hamiter) Huntsville, Alabama 35812	1
Commander US Army Electronics Command ATTN: DRSEL-PP-I-PI-1 Fort Monmouth, NJ 07703	2	NSSA-Manned Space Craft Center Reliability and Flight Safety Division ATTN: Library Houston, Texas	1
NASA Scientific & Tech Information Facility PO Box 8757 Baltimore/Washington Int'l Airport Maryland 21240	2	Commander US Army Material Development and Readiness Command ATTN: DRCRD-RS-PE-E, DRCRE-D 5001 Eisenhower Avenue Alexandria, Virginia 22333	2
Commander US Naval Air Development Center ATTN: Library Johnsville, Warminster, PA 18974	2	Chief Naval Ship Systems Command Department of the Navy ATTN: Code 681A2b, Mr. L. Gumina Room 3329 Washington, DC	1

DISTRIBUTION LIST

	<u>#</u> <u>CY</u>		<u>#</u> <u>CY</u>
Commander Naval Electronics Laboratory Center ATTN: Library San Diego, CA 92152	1	Commander Department of the NAVY, ELEX 05143A ATTN: A. H. Young Electronics System Command Washington, DC 20360	1
Commander US Naval Research Laboratory ATTN: G. Abraham 5205 Washington, DC 20390	1	Commander Defense Electronics Supply Center Directorate of Engineering & Standardization ATTN: (DESC-ECS) Mr. N. A. Hauck Dayton, Ohio 45401	1
Commander Air Research & Development Command ATTN: RDTCT Andrews Air Force Base Washington, DC	1	Amelco Semiconductor PO Box 1030 Mountain View, CA 94042	1
Avantek ATTN: Mr. Thielan 3001 Copper Road Santa Clara, CA 95051	1	AIL ATTN: Mr. Lou Ciaciulli Commack Road Deer Park, LI., New York	1
American Electronics Laboratory Richardson Road Colmar, PA	1	Alpha Industries, Inc. 20 Sylvan Road Woburn, MA 01801	1
Centralab Semiconductor 4501 North Arden Drive El Nonte, CA 91734	1	Rockwell International Collins Radio Group ATTN: Dr. Cheng Wen MS 406-246 Dallas, Texas 75207	1
Commander US Army Research Office ATTN: DRXRO-IP PO Box 12211 Research Triangle Park North Carolina 27709	1	Fairchild Semiconductor Division Fairchild Camera & Instrument Corp ATTN: Mr. Robert Skurko 313 Fairchild Drive Mountain View, CA 94040	1

DISTRIBUTION LIST

	<u>#</u> <u>CY</u>		<u>#</u> <u>CY</u>
Sanders Associates, Inc. ATTN: Microwave Department 95 Canal Street Nashua, NH 03060	1	Texas Instruments Semiconductor Components Div. ATTN: Semiconductor Library PO Box 5012 Dallas, Texas	1
Western Electric ATTN: Mr. R. Moore Marion & Vine Street Laureldale, PA	1	Varian Associates Solid State West ATTN: F. E. Rosztoczy 611 Hansen Way Palo Alto, CA 94303	1
Hughes Aircraft Corporation ATTN: Dr. Bruce Crammer 3100 West Lomita Boulevard Torrance, CA 90509	1	Texas Instruments PO Box 5936, MS 105 Dallas, Texas 75222 ATTN: Central Research Labs.	1
Commander US Army Missile Command Redstone Scientific Info. Center ATTN: Chief, Document Section Redstone Arsenal, AL 35809	1	General Motors Corporation Delco Radio Division ATTN: Box 1104 Kokomo, IN 46901	1
General Instrument Corp. Semiconductor Products Group 600 West John Street Hicksville, Long Island, NY 11802	1	Honeywell, Incorporated Semiconductor Products 2747 Fourth Avenue Minneapolis, MN 55408	1
Micro-Electronics Laboratory Hughes Aircraft Company 500 Superior Avenue Newport Beach, CA 92663	1	IBM Components Division ATTN: Mr. Al Kran East Fishkill, Rt. 52 Hopewell Junction, NY 12533	1
KSC Semiconductor Corp. ATTN: Mr. S. Cudletz, President KSC Way (Katrina Road) Chelmsford, MA 01824	1	Arthur D. Little Acorn Park ATTN: Dr. H. Rudenberg 15/206 Cambridge, MA 02140	1

DISTRIBUTION LIST

	<u>#</u> <u>CY</u>		<u>#</u> <u>CY</u>
Commander Defense Documentation Center ATTN: DDC-TCA Cameron Station, Building 5 Alexandria, VA 22314	12	General Electric Co. No. Concourse Bldg. Syracuse, NY 13212	1
Director Electronic Components Laboratory ATTN: DRSEL-TL-1J Fort Monmouth, NJ 07703	1	Director US Army Production Equipment Agency ATTN: (Mr. C. McBurney) Rock Island Arsenal Rock Island, IL 61201	1
Commander Harry Diamond Laboratories ATTN: Mr. Horst Gerlach (DRXDO-RAA) Connecticut & VanNess St. N.W. Washington, DC 20438	1	Commander US Army Materiel Development & Readiness Command ATTN: DRCPM-NXE-D (Dr. McClung) Nike X Project Office Redstone Arsenal, Alabama 35809	1
Director Electronic Components Laboratory- ATTN: DRSEL-TL-1J (Wadergin) Fort Monmouth, NJ 07703	4	Commander US Army Missile Command ATTN: DRSMI-IEVL (Mr. Buckelew) Building 4500 Redstone Arsenal, Alabama 35809	1
Office of Defense Research & Engineering Communications and Electronics Room 3D1037 Washington, DC 20330	1	MSI Electronics Inc. 32-34 57th Street Woodside, NY 11377	1
Motorola, Inc. ATTN: Mr. J. LaRue 5005 East McDowell Road Phoenix, AZ 85008	1	Northrop Corporation Laboratories ATTN: Library 320-61 3401 West Broadway Hawthorne, CA 90250	1

DISTRIBUTION LIST

	<u>#</u> <u>CY</u>		<u>#</u> <u>CY</u>
Raytheon Company Semiconductor Operation ATTN: Mr. S. Weisner 350 Ellis Street Mountain View, CA 94040	1	Dr. Robert H. Rediker Massachusetts Institute of Technology Building 13-3050 Cambridge, MA 02139	1
Sprague Electric Company ATTN: Mr. W. C. Donelan 87 Marshall Street North Adams, MA 01247	1	Raytheon Company ATTN: Dr. S. F. Paik 130 Second Avenue Waltham, MA 02154	1
US Army Missile Command ATTN: DRSMI-RGP (Mr. Victor Ruwe) Redstone Arsenal, AL 35805	1	Bell Laboratories Whippany Road ATTN: M. A. Rello, Library Whippany, NJ 07981	1
Department of Defense Deputy for Science & Technology Ofc Assist Sec Army (R&D) Washington, DC 20310	1		