

AD-A049 206

MATERIALS RESEARCH LABS ASCOT VALE (AUSTRALIA)
METHOD OF OPERATION OF THE MRL INTERFEROMETRIC MANOMETER. (U)
JUL 77 D J HATT, D B PROWSE
MRL-TN-403

F/G 14/2

UNCLASSIFIED

NL

| OF |

AD
A049206



END
DATE
FILMED
3 - 78
DDC

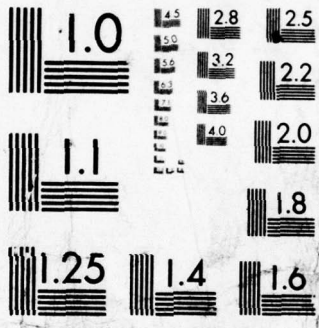

MICROCOPY RESOLUTION TEST CHART
NATIONAL BUREAU OF STANDARDS-1963-A

AD A 0 4920

MRL-TN-403

AR-000-661



125

**DEPARTMENT OF DEFENCE
DEFENCE SCIENCE AND TECHNOLOGY ORGANISATION
MATERIALS RESEARCH LABORATORIES**

MELBOURNE, VICTORIA

TECHNICAL NOTE

MRL-TN-403

METHOD OF OPERATION OF THE MRL
INTERFEROMETRIC MANOMETER

D.J. Hatt and D.B. Prowse

DDC
RECORDED
JAN 31 1978
F

Approved for Public Release



© COMMONWEALTH OF AUSTRALIA 1977

JULY, 1977

AD No. [scribble]
DDC FILE COPY

DESTROY THIS REPORT WHEN IT IS
NO LONGER NEEDED.
DO NOT RETURN IT TO THE ORIGINATOR.

THE UNITED STATES NATIONAL
TECHNICAL INFORMATION SERVICE
IS AUTHORISED TO
REPRODUCE AND SELL THIS REPORT

APPROVED
FOR PUBLIC RELEASE

DEPARTMENT OF DEFENCE
MATERIALS RESEARCH LABORATORIES

9 TECHNICAL NOTE,

14 MRL-TN-403

6 METHOD OF OPERATION OF THE MRL
INTERFEROMETRIC MANOMETER.

10 D.J./Hatt D.B./Prowse

ABSTRACT

The preparation for use and the operation of the Materials Research Laboratories interferometric manometer is described in detail. A method by which the resolution of the manometer is increased to 8 mPa is mentioned.

Approved for Public Release

11 Jul 77

12 20p.

© COMMONWEALTH OF AUSTRALIA 1977

POSTAL ADDRESS: Chief Superintendent, Materials Research Laboratories
P.O. Box 50, Ascot Vale, Victoria 3032, Australia

409014 [Signature]

DOCUMENT CONTROL DATA SHEET

Security classification of this page:

UNCLASSIFIED

- | | |
|---|---|
| <p>1. DOCUMENT NUMBERS:</p> <p>a. AR Number: AR-000-661</p> <p>b. Series & Number: TECHNICAL NOTE</p> <p>c. Report Number: MRL-TN-403 ✓</p> | <p>2. SECURITY CLASSIFICATION:</p> <p>a. Complete document: UNCLASSIFIED</p> <p>b. Title in isolation: UNCLASSIFIED</p> <p>c. Abstract in isolation: UNCLASSIFIED</p> |
|---|---|

3. TITLE:

METHOD OF OPERATION OF THE MRL INTERFEROMETRIC MANOMETER

- | | |
|--|--|
| <p>4. PERSONAL AUTHOR(S):</p> <p>HATT, D.J. and
PROWSE, D.B.</p> | <p>5. DOCUMENT DATE:</p> <p>JULY, 1977</p> |
| | <p>6. TYPE OF REPORT & PERIOD COVERED:</p> <p>TECHNICAL NOTE</p> |

- | | |
|---|--|
| <p>7. CORPORATE AUTHOR(S):</p> <p>Materials Research Laboratories</p> | <p>8. REFERENCE NUMBERS:</p> <p>a. Task: DST 50/009</p> <p>b. Sponsoring Agency:</p> |
|---|--|

- | | | |
|-----------------------------|--|--|
| <p>9. COST CODE: 454500</p> | <p>10. IMPRINT (Publishing establishment):</p> <p>Materials Research Laboratories, ✓
P.O. Box 50, Ascot Vale, Vic.3032</p> <p>JULY, 1977</p> | <p>11. COMPUTER PROGRAMME(S):</p> <p>(Title(s) and language(s)):</p> |
|-----------------------------|--|--|

12. RELEASE LIMITATIONS (of the document):

Approved for Public Release

12-0. OVERSEAS: N.O. P.R. 1 A B C D E

13. ANNOUNCEMENT LIMITATIONS (of the information on this page):

No Limitation

14. DESCRIPTORS:

Pressure measurement; Manometers

15. COSATI CODES: 1402

16. ABSTRACT (if this is security classified, the announcement of this report will be similarly classified):

The preparation for use and the operation of the Materials Research Laboratories interferometric manometer is described in detail. A method by which the resolution of the manometer is increased to 8 mPa is mentioned.

ACCEPTED	
NTIS	<input checked="" type="checkbox"/>
DDC	<input type="checkbox"/>
UNANNOUNCED	<input type="checkbox"/>
JUL 1 1977	
BY	
DISTRIBUTION/AVAILABILITY CODES	
Dist.	SPECIAL
A	

C O N T E N T S

	<u>Page No.</u>
1. INTRODUCTION	1
2. PREPARATION FOR USE	1
2.1 Installation of Floats	1
2.2 Alignment	3
2.2.1 Introduction	3
2.2.2 Alignment Procedure	3
2.2.3 Lens Adjustments	4
2.3 Optical-System Adjustments	4
3. OPERATION	5
3.1 Mechanical	5
3.2 Electrical	5
REFERENCE	6

METHOD OF OPERATION OF THE MRL
INTERFEROMETRIC MANOMETER

1. INTRODUCTION

The MRL interferometric manometer is a U-tube manometer (see Fig. 1) in which the mercury surfaces are the reflectors of a Michelson interferometer. The difference in heights of the mercury surfaces is detected and measured by use of laser interferometry techniques with a He-Ne laser. Special floats made from stainless steel and tungsten, and incorporating a cat's-eye, are used in each tube to reduce the effects of vibration.

The U-tube and the laser interferometer are mounted on a cast-iron surface plate which in turn is borne by a 5-tonne concrete block supported by air-operated anti-vibration mountings (see Fig. 2). Vacuum pumps and associated plumbing are also mounted on the surface plate.

The manometer has been described elsewhere [1]. This note is basically an instruction manual for the manometer.

2. PREPARATION FOR USE

2.1 Installation of Floats

To ensure that gas is not trapped under the floats during installation the procedure which follows has been developed so that they are placed in the mercury while both tubes are under vacuum. Initially, the mercury is drained from the tubes to the glass reservoir which rests on the cast-iron surface plate (see Fig. 3) and nitrogen* gas is leaked into both tubes until the pressure is atmospheric. The crosses (Varian vacuum-fittings) on top of each tube can then be removed. The floats are then hung in the tubes by a length (about 100 mm) of stainless-steel wire hooked over a

* In order to avoid oxidation of the mercury surfaces oxygen is excluded as far as possible from the system. Nitrogen, which is inert with respect to mercury, is used as the pressure medium.

stainless-steel rod placed horizontally in each cross (see Fig. 4). The wires need to be hooked onto both the floats and the rods in such a manner that they will easily release the floats when the tubes are refilled with mercury. To ensure that this does occur a stainless-steel ring is also hooked onto each wire between the float and rod.

The crosses are then re-fixed to each tube. The tubes are then evacuated (to less than 0.1 Pa) with the drain valve open so that the line to the reservoir is also evacuated. After pumping with the sorption pump for about 30 min, mercury can be slowly forced from the reservoir and into the tubes by leaking nitrogen gas into the space above the mercury in the reservoir. Evacuation of the tubes should continue during this procedure as a precautionary measure should there be a release of trapped gas from the reservoir system.

The required height of the mercury level in tube 1 is achieved when the top edge of float 1 is about 15 mm from the top of the tube (see Fig. 5). This distance is judged while observing the rise of the mercury in the tube through the window. The releasing of the float from the hanging wire can also be observed through the window.

The drain valve is closed when the required level in tube 1 (and hence tube 2) is obtained; the refilling process is then complete. The space above the mercury in the reservoir is then evacuated in order to minimise contamination of the unused mercury during storage between refills.

Valve V_4 (see Fig. 6) adjoining the tubes is then closed and nitrogen gas slowly leaked into tube 1. This causes the mercury level in tube 2 to rise up to support float 2 and release it from the hanging wire. The top edge of float 2 should not come to closer than about 50 mm from the top of the tube. If the edge is closer than 50 mm, float 1 may "bottom" with the likelihood of its lower sections being exposed to nitrogen gas at atmospheric pressure.

With float 2 released, tube 1 is then slowly evacuated until valve V_4 can be safely reopened. The tubes are then leaked up to atmospheric pressure using nitrogen gas and the cross on tube 2 is removed. Valve V_4 is closed again and tube 1 pressurised above atmospheric pressure (up to about 100 kPa above) to cause float 2 to rise to a convenient height for removing the hanging-wire, ring and rod. Also, the float will probably require a gentle push to overcome surface tension forces to allow it to submerge to the required level in the mercury.

The pressure in tube 1 is then allowed to fall slowly to atmospheric pressure. Valve V_4 is opened again and the cross on tube 1 is removed. The hanging wire, ring and rod are retrieved and float 1 is adjusted to float at the required level in the mercury.

The crosses are then re-fixed to both tubes, which are evacuated or filled with nitrogen at about atmospheric pressure.

2.2 Alignment

2.2.1 Introduction

The operation of the manometer depends quite critically on the alignment of the optical system relative to the U-tubes. The alignment needs to be such that significant intensity variations at the pinhole and cosine errors in height measurement do not occur. It is therefore necessary for the tubes to be vertical and for the laser beam to travel vertically and axially in the tubes at all times.

2.2.2 Alignment Procedure

The cast-iron surface plate is adjusted to be horizontal (within 2") by means of the adjusting screws on the air chambers of the 3 Serva-Level units (see Fig. 7) and by use of a suitable spirit level. The tubes are bolted approximately normal to the surface plate and supported above the plate to the main frame by adjustable clamps. The clamps are used for adjusting the tubes to be vertical to within 5".

The He-Ne laser is mounted so that its beam is horizontal as indicated by a precision spirit level placed on the upper surface of the laser. The laser is adjusted so that the spirit-level reading is the same as when the laser was placed on a horizontal granite surface plate and its beam adjusted parallel to the granite surface as indicated by a quadrant detector moved in the beam along the plate.

To facilitate alignment of the beams a 1-mm pinhole is placed within 2 cm of the laser and located centrally in the laser beam by means of a quadrant detector.

Verticality of the beams in the tubes is achieved by placing a small dish of mercury on top of each tube (see Fig. 8) and adjusting the polarisation beam splitter (3) (see Fig. 1) and the beam-bending mirror (6) until the reflected beams are located symmetrically about the 1-mm pinhole.

For locating the vertical beams centrally in the tubes two targets with 1-mm circles at their centres were made to be supported on each float. The clearance between the tube walls and the targets is about 0.01 mm. The 1-mm pinhole near the laser causes a circular diffraction pattern to be formed, and the image of this pattern and the target-circles are magnified by the use of telescopes (see Fig. 9). When the circular diffraction patterns are concentric with the target-circles the laser beams will be central in the tubes.

For making adjustments for the conditions of verticality and centrality the laser is mounted on a plate that can be rotated in a horizontal plane. Also, the polarisation beam splitter and the beam-bending mirror are fixed to mirror mounts which permit rotation about two orthogonal axes, one axis being parallel to the laser beam. Moreover, the beam splitter is mounted on a table with movement in a horizontal direction. Both this table and the mirror mount for the beam-bending mirror are mounted on a vertical steel plate that can be moved horizontally.

To check the alignment, tube 1 is pressurised to about 100 kPa above atmospheric pressure and the target-circles are again observed to ascertain centrality of the diffraction patterns. When the alignment is satisfactory, the targets are removed from both tubes.

2.2.3 Lens Adjustments

The 1-mm pinhole in front of the laser is replaced with a hole of the same diameter as the laser beam (about 6 mm). The hole is cut in a piece of white card and positioned centrally in the laser beam.

The lens for float 1 can then be inserted into its lens holder and adjusted to focus near the mercury surface; experience has shown that at atmospheric pressure the reflected beam should be slightly divergent. When the divergent beam is viewed on the white card it should be about 8 mm in diameter. The beam should also be checked at several points along its path to ensure that it is not converging to a focus and then diverging onto the card. Moreover, the beam should be located symmetrically around the hole, and generally, to achieve this condition, a small lateral adjustment of the lens is required. The fit of the lens into the lens holder is such that this adjustment can be made by gently tapping the lens in the required direction with a stainless-steel rod.

The procedure for the insertion and adjustment of the lens for float 2 is the same as above except that the mercury level in tube 2 needs to be raised to allow access to float 2. Also, since the reflected beam path to the laser will then be less, the diameter of the divergent beam at the white card only needs to be slightly larger than 6 mm.

2.3 Optical-System Adjustments

The linearly polarised light from the laser is converted to circularly polarised light after passing through the $\lambda/4$ plate (2) near the laser. The optic axis of this $\lambda/4$ plate needs to be set at 45° to the azimuth of vibration of the linearly polarised light. If a polaroid analyser is rotated in the circularly polarised beam there should be no observable intensity variation in the beam emergent from the analyser.

The $\lambda/4$ plates (4) and (5) are rotated so that the linearly polarised beams emergent from the polarisation beam-splitter pass into the tubes as circularly polarised light. A convenient method for adjusting the $\lambda/4$ plates is to rotate them until there is a minimum return of the beam back to the laser.

The optic axis of the $\lambda/4$ plate (9) immediately above the polarisation beam-splitter is set to convert the linearly polarised beams emergent from the beam-splitter to circularly polarised beams. As before, a polaroid analyser can be used as a test for circularly polarised light.

The 400- μm pinhole (10) is located centrally in the overlapping beams and the beam-splitter (11) is then used to direct the emergent beam from the pinhole to the photomultipliers (14) and (15). The pinhole diameter of 400 μm was chosen because it was found by experiment to give the best compromise between minimum "jitter" on the CRO (discussed below) and

maximum signal-to-noise ratio on the output. The photomultipliers are housed in brass casings and the housings have small holes to allow the beams through to the photomultiplier end-windows. Finally, the polarising directions of the polaroid analysers (12) and (13) are set at 45° to each other. The fine adjustment of this angle is most easily done when viewing the Lissajous figure on the CRO (described in section 3.2) which should be a circle (provided that the input signals are of equal amplitude).

3. OPERATION

3.1 Mechanical

A pressure measurement is commenced with both arms of the manometer under vacuum. Even though the ion pump is available for use it has been found that the sorption pump is generally all that is required to obtain a suitable vacuum. This then avoids the use of cold traps; strictly speaking cold traps should also be used with the sorption pump but for convenience they are not used and as no detrimental effects arising from mercury contamination have been observed after a few years of use, this practice is considered satisfactory. Valves V_1 , V_3 and V_4 are opened for evacuating the tubes, while V_5 should be opened to evacuate the comparison instrument and then closed again.

With the reversible counter set to zero and valves V_2 , V_4 and V_6 closed, nitrogen gas is slowly admitted to tube 1 via V_7 , V_5 being re-opened first. As the pressure increases, fringes are counted (at a maximum count rate of about 10 kHz) until the desired pressure is obtained. The pressure is then slowly reduced to vacuum via V_6 to return the counter to zero. Valve V_5 is then closed and V_4 re-opened to ensure that there is no differential pressure between the two arms. The valves V_7 and V_6 for admitting and removing the nitrogen gas from the manometer are glass-teflon needle valves which provide the necessary fine pressure control.

3.2 Electrical

The HV power supply is set to about 700 V so that the output signals from the photomultipliers are about 1 V peak-to-peak. The supplies to the photomultipliers are adjusted independently so that the two output signals are equal. The output signals are connected to inputs 1 and 2 of the trigger level compensator (TLC, see Fig. 10) and also to the X and Y axes of the CRO. Outputs A and B from the TLC are connected to the corresponding A and B inputs of the reversible counter. The function of the TLC is to make adjustments automatically (that otherwise would need to be made manually) to the triggering levels on the reversible counter. These adjustments are necessary because the output signals from the photomultipliers are not constant due to intensity changes at the 400- μ m pin-hole. The output signals from the TLC are 1 V peak-to-peak square-wave signals for input signals over the voltage range 0.1 to 5 V peak-to-peak.

In operation it is found that the floats have a certain degree of stick-slip motion which causes "jitter" or radial broadening of the circle on the CRO. Excessive jitter will cause the signal to drop below the triggering levels with consequent loss of counts. This effect can be observed if the counting rate exceeds about 10 kHz. The circle is also used as a guide to the execution of smooth pressure changes when starting and stopping a run.

Increased resolution of the manometer may be obtained by connecting the digital output of the counter to a digital-to-analog converter and then to a strip chart recorder. The slower response of the recorder damps out some of the vibration, which is typically about 3/4 to 1 fringe in amplitude, enabling a resolution of 0.2 fringe (8 mPa) to be obtained from the recorder trace.

REFERENCE

1. Harrison, E.R., Hatt, D.J., Prowse, D.B. and Wilbur-Ham, J. A New Interferometric Manometer. *Metrologia*, 12, 3, (1976).

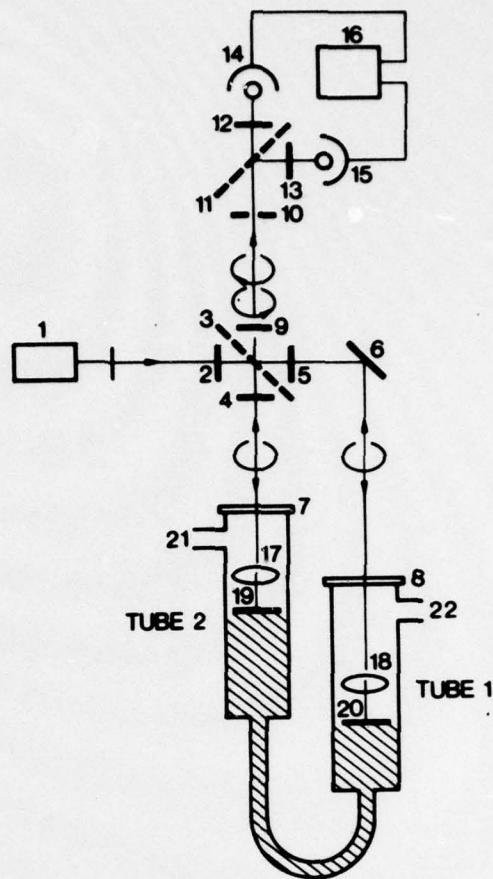

FIG. 1 - Operating principle of the manometer.

- | | |
|---------|----------------------------|
| 1 | He-Ne laser |
| 2,4,5,9 | quarter-wave plates |
| 3 | polarisation beam splitter |
| 6 | beam-bending mirror |
| 7,8 | windows |
| 10 | 400- μ m pinhole |
| 11 | beam splitter |
| 12,13 | polaroid analysers |
| 14,15 | photomultipliers |
| 16 | reversible counter |
| 17,18 | floating cat's-eyes |
| 19,20 | free mercury surfaces |
| 21 | to high vacuum |
| 22 | to pressure source |

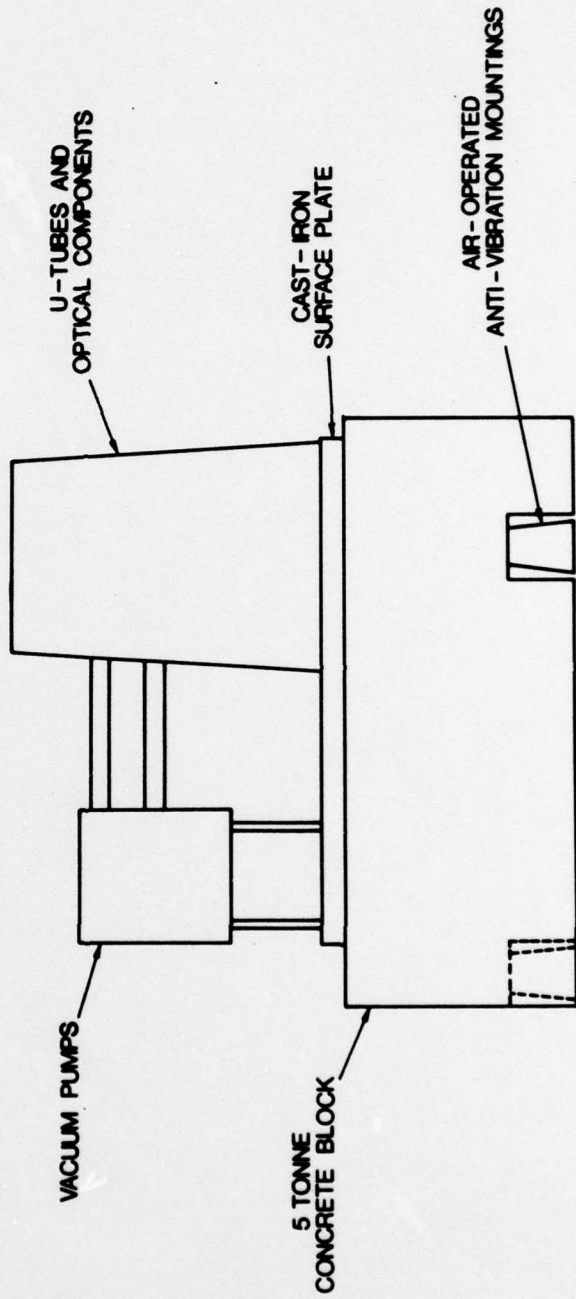

FIG. 2 - Schematic diagram of the manometer.

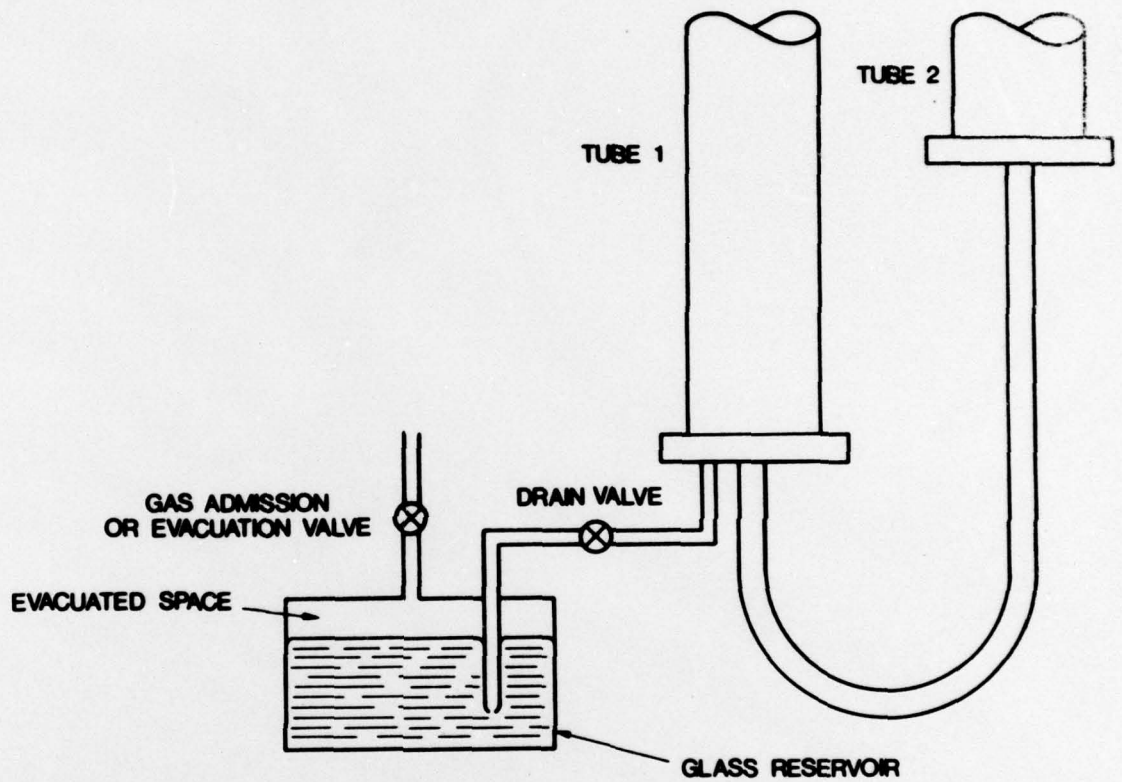

FIG. 3 - Schematic diagram showing the mercury reservoir.

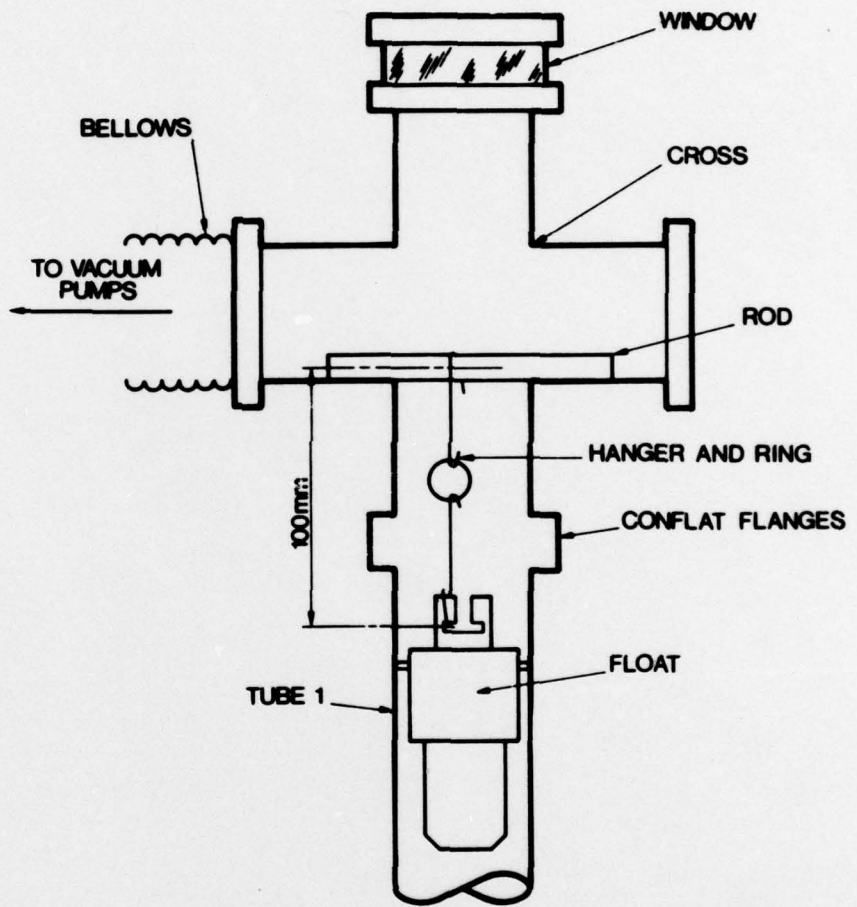

FIG. 4 - Schematic diagram showing the float in tube 1 suspended by a hanger and ring.

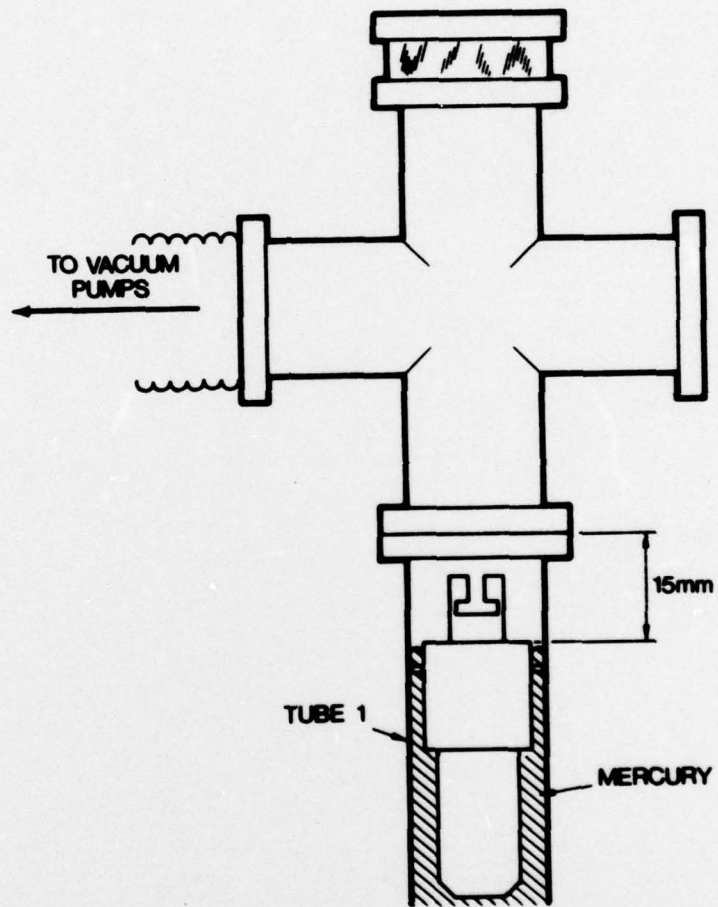

FIG. 5 - Schematic diagram showing the level of mercury required in tube 1.

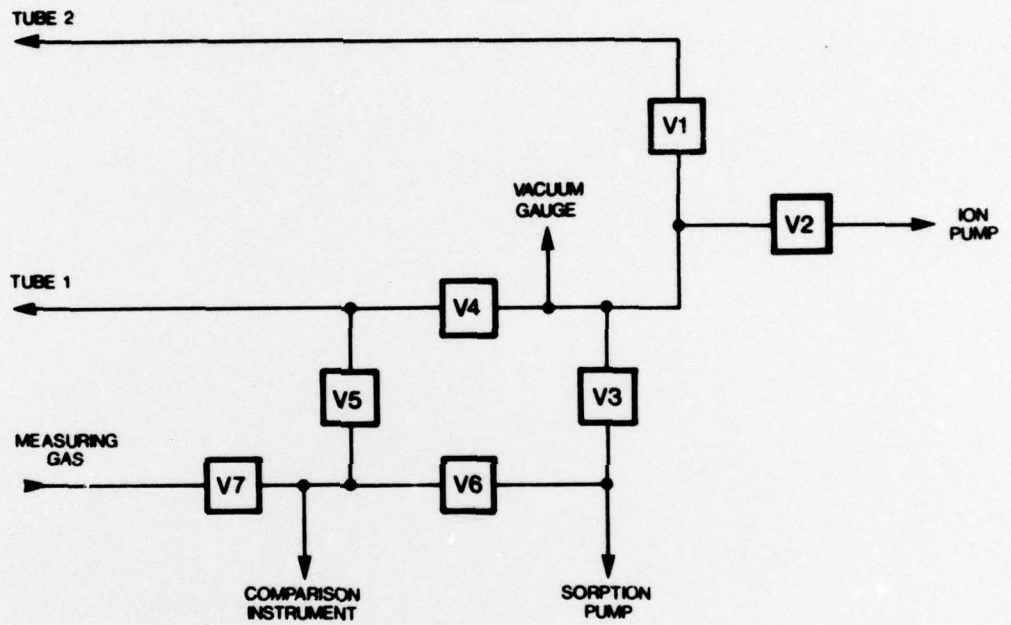

FIG. 6 - Schematic diagram of the vacuum system :
 V_1 - V_5 , high vacuum valves; V_6 , V_7 ,
 needle valves.

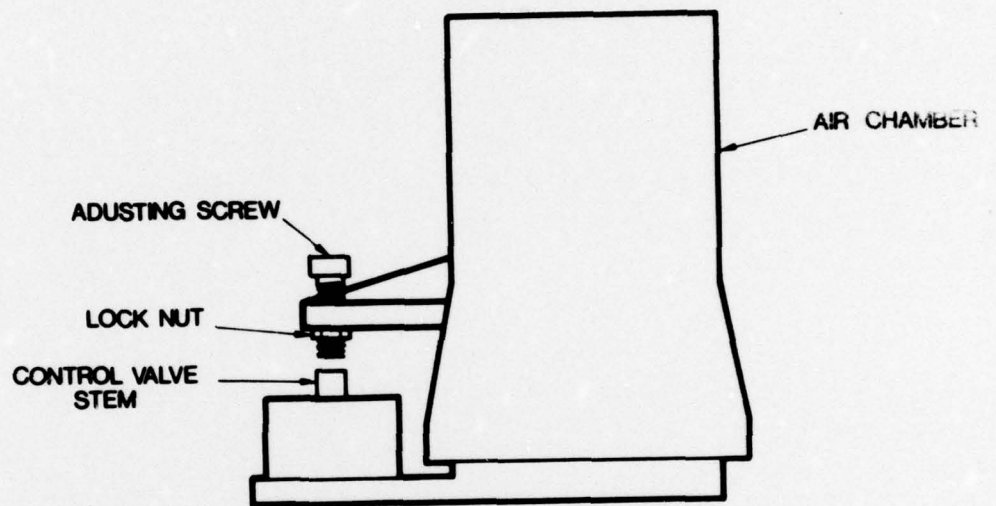

FIG. 7 - Schematic diagram of a Serva-Level unit.

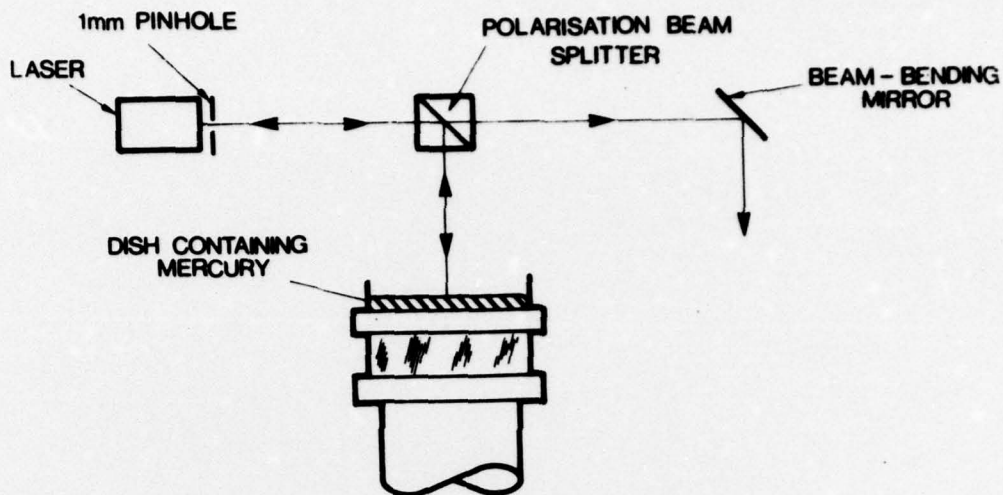

FIG. 8 - Schematic diagram showing the method of determining verticality of the laser beam.

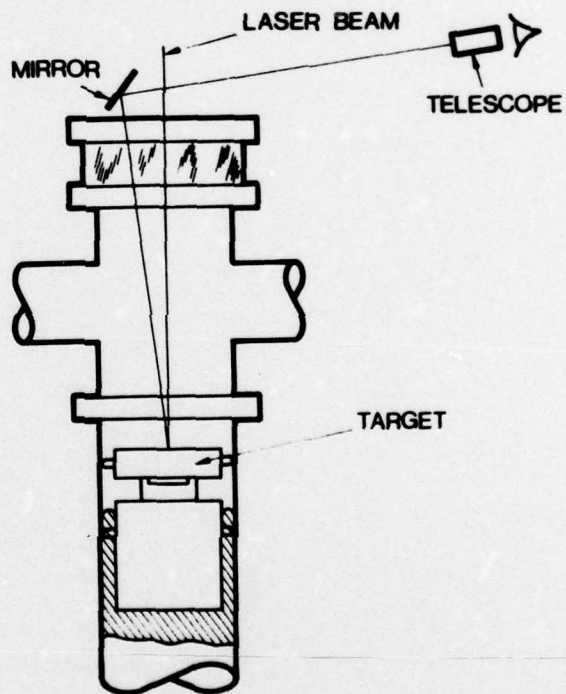

FIG. 9 - Schematic diagram showing the method for determining centrality of the laser beam in the tube.

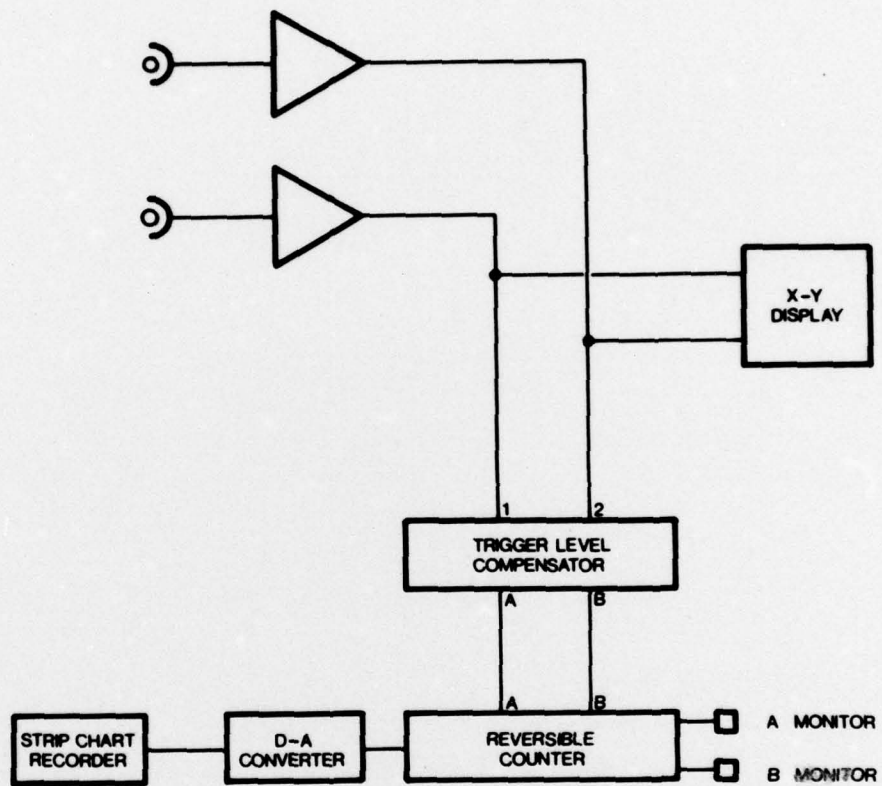

FIG. 10 - Schematic diagram of the electrical system.

(MRL-TN-403)

DISTRIBUTION LIST

MATERIALS RESEARCH LABORATORIES

Chief Superintendent
Superintendent, Physics Division
Mr. E.R. Harrison
Mr. D.J. Hatt
Dr. D.B. Prowse
Library
Librarian, N.S.W. Branch (Through Officer-in-Charge)
Officer-in-Charge, Joint Tropical Research Unit

DEPARTMENT OF DEFENCE

Chief Defence Scientist
Executive Controller, ADSS
Superintendent, Defence Science Administration, DSTO
Superintendent, Military Advisers Branch
Head, Laboratory Programs Branch
Army Scientific Adviser
Air Force Scientific Adviser
Naval Scientific Adviser
Chief Superintendent, Aeronautical Research Laboratories
Director, Weapons Research Establishment
Senior Librarian, Weapons Research Establishment
Librarian, R.A.N. Research Laboratory
Document Exchange Centre, DLSI (16 copies)
Principal Librarian, Campbell Park Library ADSATIS Annex
Directorate of Quality Assurance (Air Office)
Head, Engineering Development Establishment

DEPARTMENT OF PRODUCTIVITY

NASA Canberra Office
Head, B.D.R.S.S. (Aust.)

OTHER FEDERAL AND STATE DEPARTMENTS AND INSTRUMENTALITIES

The Chief Librarian, Central Library, C.S.I.R.O.
Australian Atomic Energy Commission Research Establishment
The Librarian, National Measurement Laboratory, C.S.I.R.O.

D

(MRL-TN-403)

DISTRIBUTION LIST

(Continued)

MISCELLANEOUS - OVERSEAS

Defence Scientific & Technical Representative, Department
of Defence, England
Assistant Director/Armour and Materials, Military Vehicles
and Engineering Establishment, England
Reports Centre, Directorate of Materials Aviation, England
Library - Exchange Desk, National Bureau of Standards, U.S.A.
U.S. Army Standardization Group, Office of the Scientific
Standardization Representative, Canberra, A.C.T.
Senior Standardization Representative, U.S. Army
Standardization Group, Canberra, A.C.T.
Chief, Research and Development, Defence Scientific
Information Service, Canada (2 copies)
The Director, Defence Scientific Information and
Documentation Centre, India
Colonel B.C. Joshi, Military, Naval and Air Adviser,
High Commission of India, Red Hill, A.C.T.
Director, Defence Research Centre, Malaysia
Accessions Department, British Library, England
Official Publications Section, British Library, England
Librarian, Periodicals Recording Section, National Reference
Library of Science and Invention, England
INSPEC: Acquisition Section, Institution of Electrical
Engineers, England
Overseas Reports Section, Defence Research Information Centre,
England
Director, National Physical Laboratory, England
Science Information Division, Department of Scientific and
Industrial Research, New Zealand.

