

AD-A049 322

HUGHES RESEARCH LABS MALIBU CALIF
OPTICAL-MICROWAVE INTERACTIONS IN SEMICONDUCTOR DEVICES.(U)
JAN 78 H YEN, M K BARNOSKI

F/G 9/5

N00173-77-C-0156

NL

UNCLASSIFIED

| OF |

ADAO49322



END
DATE
FILMED
3 - 78
DDC

AD A 0 49322

12

19

OPTICAL-MICROWAVE INTERACTIONS IN SEMICONDUCTOR DEVICES

JDC FILE COPY

Huan-Wun Yen and Michael K. Barnoski

Hughes Research Laboratories
3011 Malibu Canyon Road
Malibu, CA 90265

January 1978

Contract N00173-77-C-0156
Quarterly Report 2
For Period 15 September 1977 through 16 December 1977

Approved for public release; distribution unlimited

Prepared For
NAVAL RESEARCH LABORATORY
4555 Overlook Avenue, S.W.
Washington, DC 20375

DDC
RECEIVED
FEB 1 1978
B

[Handwritten signature]

UNCLASSIFIED

SECURITY CLASSIFICATION OF THIS PAGE (When Data Entered)

REPORT DOCUMENTATION PAGE		READ INSTRUCTIONS BEFORE COMPLETING FORM
1. REPORT NUMBER	2. GOVT ACCESSION NO.	3. RECIPIENT'S CATALOG NUMBER
6. OPTICAL-MICROWAVE INTERACTIONS IN SEMICONDUCTOR DEVICES.		9. 5. TYPE OF REPORT & PERIOD COVERED Quarterly Report, no. 2, 15 Sep [redacted] - 16 Dec 1977
10. 7. AUTHOR(s) Huan-wun Yen and Michael K. Barnoski		15. 8. CONTRACT OR GRANT NUMBER(s) N00173-77-C-0156 NEW
9. PERFORMING ORGANIZATION NAME AND ADDRESS Hughes Research Laboratories 3011 Malibu Canyon Road Malibu, CA 90265		10. PROGRAM ELEMENT, PROJECT, TASK AREA & WORK UNIT NUMBERS 12 31 p.
11. CONTROLLING OFFICE NAME AND ADDRESS Naval Research Laboratory 4555 Overlook Ave., S.W. Washington, D.C. 20375		11. 12. REPORT DATE Jan [redacted] 78
14. MONITORING AGENCY NAME & ADDRESS (if different from Controlling Office)		13. NUMBER OF PAGES 31
		15. SECURITY CLASS. (of this report) Unclassified
		15a. DECLASSIFICATION DOWNGRADING SCHEDULE
16. DISTRIBUTION STATEMENT (of this Report) Approved for public release; distribution unlimited.		
17. DISTRIBUTION STATEMENT (of the abstract entered in Block 20, if different from Report)		
18. SUPPLEMENTARY NOTES		
19. KEY WORDS (Continue on reverse side if necessary and identify by block number) GaAs FET oscillator, Amplifier, Microwave mixing, Optical injection locking, Injection laser modulation.		
20. ABSTRACT (Continue on reverse side if necessary and identify by block number) The design and fabrication of a GaAs FET microwave oscillator was described. The optical injection locking property of this oscillator was studied. It was also found that the frequency jitter of the oscillator output could be reduced through optical illumination. A novel scheme of microwave mixing in a GaAs FET amplifier was demonstrated, where the local oscillator signal was introduced through optical → next page		

172 600

mt

UNCLASSIFIED

SECURITY CLASSIFICATION OF THIS PAGE(When Data Entered)

injection. A new approach of obtaining optical injection locking of oscillators was developed where a FET amplifier was connected to the oscillator to be locked and the modulated laser beam was used to illuminate the amplifier instead of the oscillator directly. The merits and disadvantages of this technique was discussed. The direct amplitude modulation speed of a single mode GaAlAs injection laser was found to be at least 6 GHz. The output power versus input current characteristic of the same laser was determined to be better than -40 dB in second harmonic distortion.

ACCESSION for	
NTIS	White Section <input checked="" type="checkbox"/>
DDC	Buff Section <input type="checkbox"/>
UNANNOUNCED	<input type="checkbox"/>
JUSTIFICATION	_____
BY	
DISTRIBUTION/AVAILABILITY CODES	
Dist.	AVAIL. and/or SPECIAL
A	

UNCLASSIFIED

SECURITY CLASSIFICATION OF THIS PAGE(When Data Entered)

PREFACE

The following personnel contributed to the research work reported here: H. W. Yen, M. K. Barnoski, R. L. Abrams, E. E. Herman, A. Yariv (consultant), and D. F. Lewis. D. Pierson, R. Dimon, and C. Meijer assisted in the fabrication of GaAs FET oscillator. The P-band GaAs FET amplifier used in the mixing experiment was supplied by G. Keithley of Hughes Aircraft Company, El Segundo, California. The high-speed GaAs avalanche photodiode was supplied by F. Blum of Science Center, Rockwell International, Thousand Oaks, California. The single-mode injection laser linearity measurements were done partially on a Los Alamos Scientific Laboratories contract "Studying the Use of Integrated Optics Techniques in Underground Nuclear Test Applications."

TABLE OF CONTENTS

Section		Page
1	INTRODUCTION	6
2	DESIGN, FABRICATION, AND OPTICAL INJECTION LOCKING OF A GaAs FET OSCILLATOR	8
3	OPTICALLY INJECTED MICROWAVE IN GaAs FET AMPLIFIER	15
4	INJECTION LOCKING OF A 440-MHz OSCILLATOR BY OPTICAL ILLUMINATION OF AN AMPLIFIER	21
5	DIRECT MODULATION OF INJECTION LASERS	24
6	PLANS FOR THE NEXT QUARTER	28
7	SUMMARY	29
	REFERENCES	30

LIST OF ILLUSTRATIONS

Figure		Page
1	Design of a GaAs FET common source oscillator with series feedback element	10
2	Schematic of the designed GaAs FET oscillator.	12
3	Photograph of the completed GaAs FET oscillator module	12
4	Oscilloscope displays of the GaAs FET oscillator output	14
5	Schematic of the optically injected microwave mixing experiment	16
6	Gain versus frequency plot of a single-stage GaAs FET amplifier	16
7	Spectrum analyzer display of the GaAs FET amplifier output	17
8	Simplified analysis of the mixing process.	19
9	Schematics of two optical injection locking schemes	22
10	Oscilloscope traces of modulated injection laser output	25
11	Linearity measurement of laser output power versus driving current characteristics	27

SECTION 1

INTRODUCTION

Because the carrier-generation process in semiconductors is light-sensitive, the characteristics of a variety of semiconductor devices can be modified or controlled with optical illumination. For example, a GaAs IMPATT diode oscillator has been switched on and off optically,¹ the turn-on phase jitter of a TRAPATT oscillator has been substantially reduced by optical illumination,² and a silicon transistor oscillator has been switched and phase locked simultaneously by an injected optical signal.³ The purpose of our program is to fully understand the interaction physics and to explore new applications.

During the first quarter, we performed the theoretical and experimental studies of direct modulation of semiconductor lasers. We also demonstrated optical injection locking of transistor oscillators at frequencies up to 1.8 GHz. During the second quarter, we carried out the design and fabrication of a GaAs FET oscillator. The oscillator had a stable oscillation frequency of 7 GHz and was successfully phase locked to a 3.5-GHz signal generator through optical injection. A novel approach to achieving microwave mixing in a GaAs FET amplifier was also developed. The incoming microwave signal was fed to the input port of the amplifier, while the local oscillator signal was carried by a laser beam and optically injected into the FET circuit. The mixed signals were taken from the output port of the amplifier. For example, we put a 12.4-GHz signal into an FET amplifier while illuminating the FET chip with a laser beam modulated at 3.51 GHz to obtain mixed frequencies at 8.89 GHz and 5.38 GHz.

Optical injection locking of a 440-MHz oscillator was achieved with a new arrangement. Instead of illuminating the transistor in the oscillator circuit directly, we illuminated the transistor in an amplifier connected to the oscillator. This technique is useful if the solid-state oscillator is not easily accessible for illumination.

With a recently acquired high-speed GaAs avalanche photodiode (APD), we were able to determine that our single-mode injection laser can be modulated up to 6 GHz. The output power of single-mode lasers is linearly proportional to the drive current. With an improved driving circuit, we were able to determine that, for small-signal modulation at 1 GHz, the second harmonic distortion was at least 40 dB down in the output signal.

SECTION 2
DESIGN, FABRICATION, AND OPTICAL INJECTION LOCKING
OF A GaAs FET OSCILLATOR

As part of the study of optical injection locking of microwave solid-state oscillators, we designed and fabricated a GaAs FET oscillator during this quarter. The GaAs FET chips used were fabricated by Hughes Research Laboratories (HRL) under the low-noise GaAs FET project. The channel of these FETs was formed by ion implantation of Si into Cr-doped, bulk-grown substrates at room temperature. The gate electrode was 300 μm wide and 0.5 μm long.

The basic FET oscillator circuit was chosen to be the common source configuration with a series feedback element. The common source S-parameters of the FET chips were obtained. The FETs are mounted in a microstrip carrier for ease of handling and measurement. A Hewlett-Packard network analyzer was used over the 4 GHz to 12 GHz frequency range to characterize the chips in terms of S-parameters. This measurement was then repeated using a microstrip through line in place of the chip carrier. The data from these two measurements were fed into a computer where a computer program separated the S parameter of the FET chip from that of the carrier.

For a representative FET chip at 10 GHz under the following bias condition

$$V_{DS} = 2.5 \text{ V}$$

$$V_{GS} = -1.2 \text{ V}$$

$$I_{DS} = 25 \text{ mA,}$$

the S-parameters were found to be

$$S_{11} = 0.674 \angle -53^\circ$$

$$S_{12} = 0.042 \angle 135^\circ$$

$$S_{21} = 1.427 \angle 107^\circ$$

$$S_{22} = 0.787 \angle -52^\circ .$$

Consider the common source configuration with series feedback element Z_f , as shown in Figure 1(a). The overall input reflection coefficient S'_{11} of the composite circuit can be calculated if the S-parameters of the FET and the value of Z_f are known.⁴ The value of Z_f should be chosen such that $|S'_{11}| > 1$. This will make the circuit unstable, a necessary condition for the circuit to oscillate. In other words, the circuit should exhibit negative resistance at the output terminal so that a proper termination can cause it to oscillate at the desired frequency. After some calculation, the feedback element was chosen to be a capacitor with $c = 0.35$ pF, corresponding to $Z_f = -j45.5 \Omega$ at 10 GHz, and the calculated S'_{11} was

$$S'_{11} = 1.107 \angle -52^\circ .$$

Next, a resonant element Z_R was introduced between the gate of the FET and ground to tune out the imaginary part of S'_{11} . This was realized using a section of shorted microstrip line that has a characteristic impedance of 50Ω and is electrically 64° long. This is shown in Figure 1(b). The output impedance of this combined circuit Z_{out} was then calculated to be

$$Z_{out} = (-71.6 + j52.0) \Omega .$$

The output-matching circuit was determined to optimize the oscillator output power;⁵ thus

$$\text{Re}(Z_L) \approx 1/3 |\text{Re}(Z_{out})| = 24 \Omega$$

$$\text{Im}(Z_L) = -\text{Im}(Z_{out}) = -52 \Omega$$

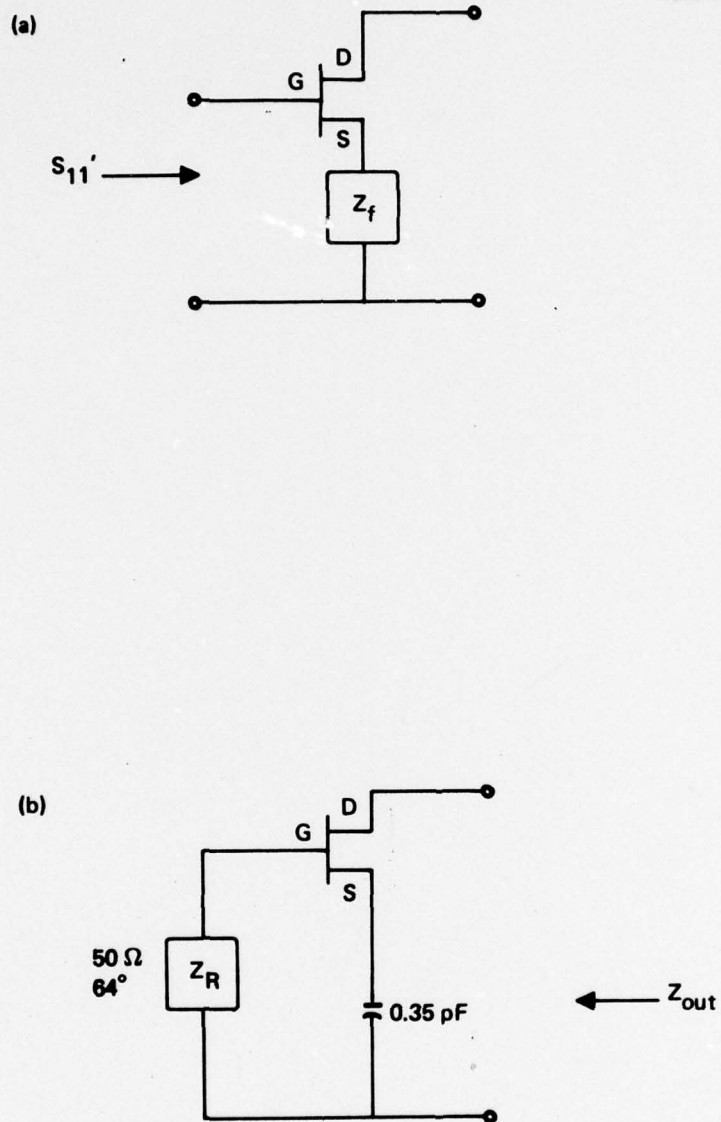

Figure 1. Design of a GaAs FET common source oscillator with series feedback element.

or

$$Z_L = (24 - j52) \Omega .$$

This was realized with a section of transmission line (50Ω , 17°), a capacitor (0.2 pF), and a 50Ω output load impedance. The completed circuit diagram is shown in Figure 2, which also includes the bias circuit. The two quarter-wavelength (90°) microstrip lines act as an rf choke, and the 1000 pF capacitors are by-pass capacitors.

To fabricate an FET oscillator based on this design, the first step was to reduce the circuit diagram to a practical layout. The circuit was constructed on a 0.6-mm-thick alumina substrate. To obtain a microstrip line with a characteristic impedance of 50Ω , the ratio of the linewidth w to the substrate thickness h is

$$w/h = 1.0 .$$

and, for a microstrip line with 150Ω characteristic impedance, the ratio is

$$w/h = 0.025$$

Therefore, at 10 GHz, a 64° , $50\text{-}\Omega$ line translates into a line with the dimensions 0.6 mm x 2.1 mm, and a 17° , $50\text{-}\Omega$ line translates into a line 0.6 mm x 0.6 mm. The $150\text{-}\Omega$ quarter-wavelength line has the dimensions 0.02 mm x 3.1 mm.

The circuit layout was then made into a photomask, and the pattern was photolithographically and chemically etched into a gold plating deposited on the alumina substrate. Next the etched substrate was mounted in a brass housing, and the GaAs FET chip and the various capacitors were mounted in place on the substrate. Finally the bias pins and output port connections were installed. A photograph of the completed oscillator module is shown in Figure 3.

Although the oscillator was originally designed to operate at 10 GHz, the circuit barely oscillated at this frequency. But the circuit

7032-2

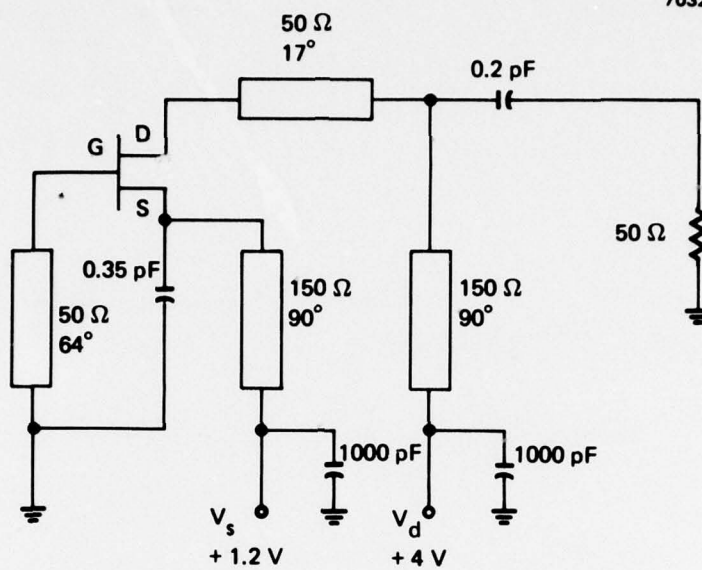

Figure 2. Schematic of the designed GaAs FET oscillator.

7032-3

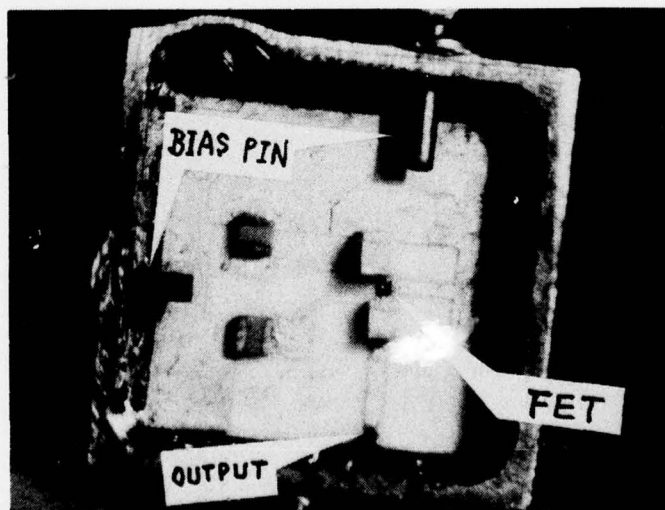

Figure 3. Photograph of the completed GaAs FET oscillator module.

oscillated quite stably at 7 GHz when biased at $V_D = +4V$ and $V_S = -1V$. The main reason for this discrepancy was that the FET chip S-parameters varied from chip to chip even though the chips had been diced from the same wafer. A secondary reason was that stray inductance and capacitance was introduced during circuit construction and therefore the circuit probably was too lossy at 10 GHz to sustain a stable oscillation. As a matter of fact, the oscillation at 10 GHz was so unstable that, when the FET was illuminated by the laser beam, the oscillation frequency jumped to 7 GHz and remained at this frequency even though the laser beam was blocked. Figure 4 shows the sampling oscilloscope display of the oscillator output at 10.3 GHz and 7 GHz, respectively.

The output frequency of the oscillator was voltage tunable over a limited range. The output power at 7 GHz was about 1 mW. Under certain bias conditions, the output frequency of the oscillator was not very stable; a frequency drift as large as 1.6 MHz was observed. DC optical illumination was able to reduce this frequency drift to less than 0.2 MHz. The reason for this improvement is not clear at this time and will be investigated in more detail. Since we were not able to modulate our injection laser at 7 GHz, to check the optical injection locking of our oscillator we had to use subharmonics of 7 GHz as our locking signal. Therefore, we modulated the laser at 3.5 GHz and focused its output onto the FET in the oscillator circuit and achieved optical injection locking of the 7-GHz oscillator. The locking range in this case was very small and believed to be a combination of poor optical coupling and the fact that subharmonic locking was used.

7032-4

(a)

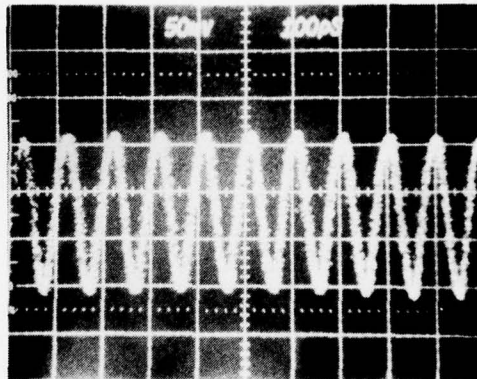

(b)

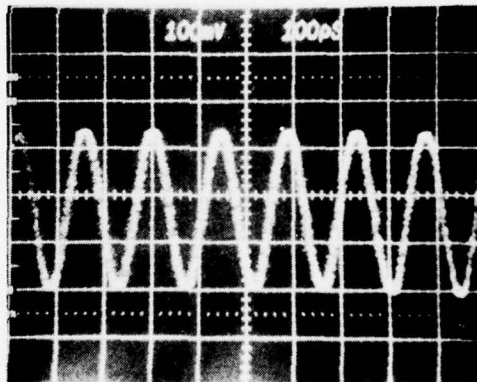

Figure 4. Oscilloscope displays of the GaAs FET oscillator output.
(a) at 10.3 GHz and
(b) at 7 GHz.

SECTION 3

OPTICALLY INJECTED MICROWAVE IN GaAs FET AMPLIFIER

To test the feasibility of using a GaAs FET amplifier as a microwave mixer, the experiment illustrated in Figure 5 was carried out. By feeding a 12.4-GHz microwave signal into a GaAs FET amplifier while simultaneously illuminating the FET with a laser beam modulated at 3.51 GHz, we were able to obtain, at the output port of the amplifier, a signal that contained frequency components of 12.4 GHz, 8.89 GHz, and 5.38 GHz. Note that

$$8.89 \text{ GHz} = 12.4 \text{ GHz} - (1 \times 3.51) \text{ GHz}$$

and

$$5.38 \text{ GHz} = 12.4 \text{ GHz} - (2 \times 3.51) \text{ GHz} .$$

This result showed that mixing can take place with the arrangement described above. Here the amplifier input represents the incoming microwave signal, the signal carried by the laser beam acts as the local oscillator output, and the intermediate frequency (IF) signal is taken from the output port of the amplifier.

The amplifier used in the experiment was a single-stage GaAs FET chip amplifier. The gain versus frequency plot of this device is shown in Figure 6. At 12.4 GHz, the amplifier has a gain of about 7.6 dB. A sweep oscillator was used to generate the 12.4 GHz input signal. The output of the amplifier was connected to a spectrum analyzer. Figure 7(a) shows a spectrum analyzer display of the amplified 12.4 GHz straight through signal when the FET was not illuminated. Figure 7(b) shows the spectrum of the amplifier output when the FET was illuminated by a laser beam modulated at 3.51 GHz. Besides the original 12.4 GHz signal, two new frequency components were generated (at 8.89 GHz and 5.38 GHz). Figure 7(c) is an oscilloscope trace of the injection laser output modulated at 3.51 GHz. The optical zero-power level is as indicated in the picture. Thus, the modulation index of the laser output can be found to be $\sim 12\%$.

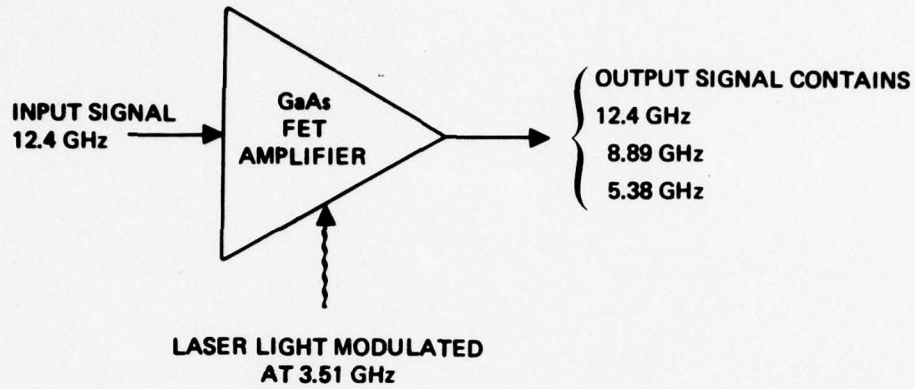

Figure 5. Schematic of the optically injected microwave mixing experiment.

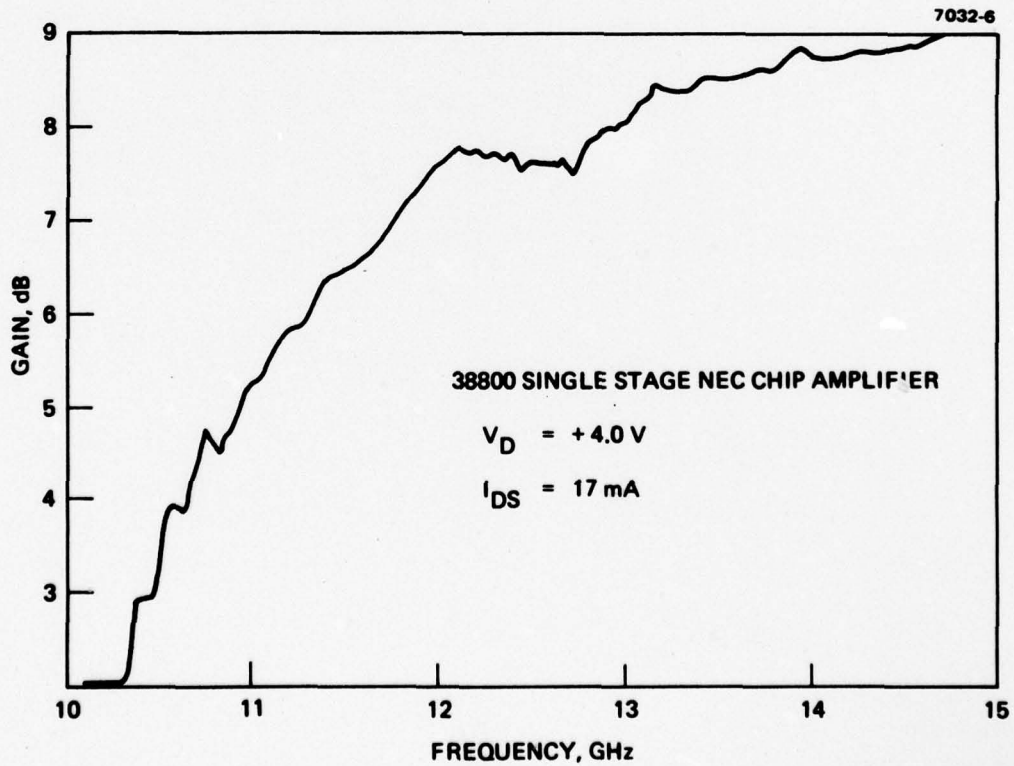

Figure 6. Gain versus frequency plot of a single-stage GaAs FET amplifier.

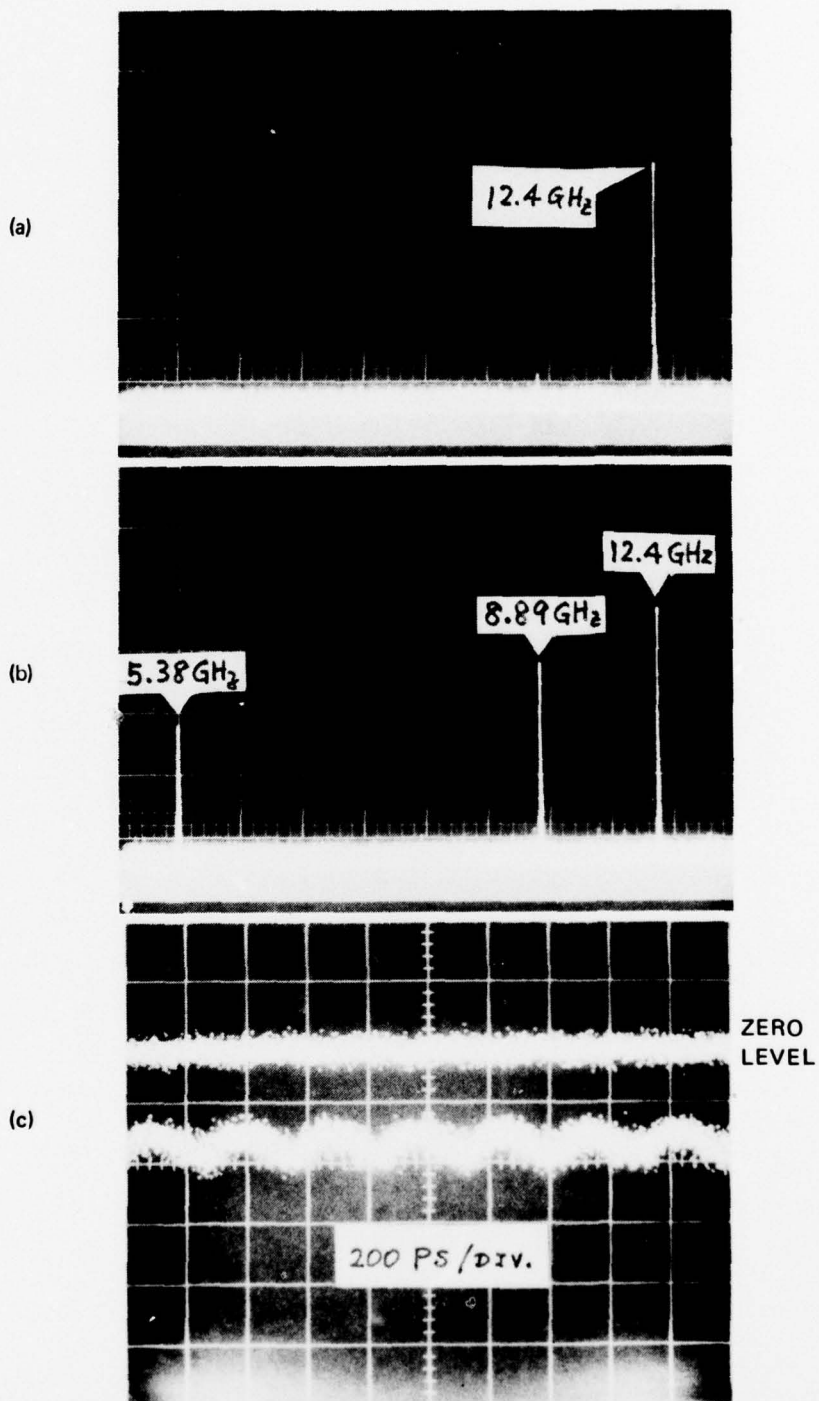

Figure 7. (a) and (b): Spectrum analyzer display of the GaAs FET amplifier output. (c) oscilloscope display of the modulated laser output at 3.51 GHz.

A simplified analysis of this mixing process is illustrated in Figure 8. Assume that a signal of the form

$$E_0 \sin \omega_0 t,$$

where E_0 is the amplitude of the signal, and ω_0 is its angular frequency, is fed to an amplifier with voltage gain A. Then the amplifier output is

$$AE_0 \sin \omega_0 t .$$

Now assume that a dc optical illumination causes the amplifier gain to vary and the amount of change is proportional to the light intensity. This is illustrated in Figure 8(b) where a dc optical illumination of intensity I on the amplifier changes the output to

$$A\beta E_0 \sin \omega_0 t .$$

If the light is intensity modulated sinusoidally at frequency ω (i.e., the light intensity is of the form $I(1 + m \sin \omega t)$, where I is the average intensity and m is the modulation index), then the amplifier output will be

$$A\beta E_0 (1 + m \sin \omega t) \sin \omega_0 t .$$

It is easy to show that

$$\begin{aligned} A\beta E_0 (1 + m \sin \omega t) \sin \omega_0 t &= A\beta E_0 \sin \omega_0 t + \frac{mA\beta E_0}{2} \cos (\omega_0 - \omega)t \\ &\quad - \frac{mA\beta E_0}{2} \cos (\omega_0 + \omega)t . \end{aligned}$$

Therefore, the output signal will have frequency components at ω_0 , $\omega_0 - \omega$, and $\omega_0 + \omega$. The ratio of the amplitudes of these components is

$$1 : \frac{m}{2} : \frac{m}{2} .$$

Since the modulation index of the laser (as shown in Figure 7(c)) is 0.12 and since the output power carried by the component $\omega_0 - \omega$ is $(m/2)^2$ times that carried by the ω_0 component, it is approximately 24 dB down in this case. However, Figure 7(b) shows that the power at 8.89 GHz is only about 11 dB down from the 12.4 GHz signal. Our explanation is that the 12.4 GHz signal suffers a much larger attenuation

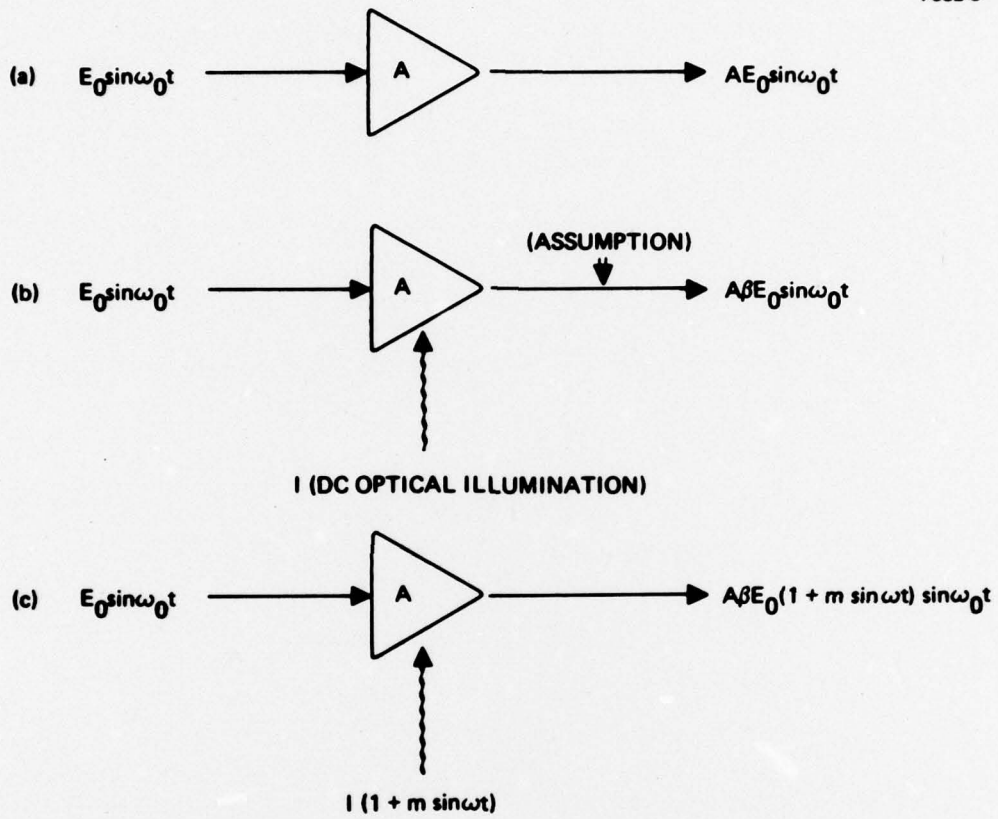

Figure 8. Simplified analysis of the mixing process.

than the 8.89 GHz signal due to the coaxial cable and the various connectors along the signal path. The reason that the higher frequency component $\omega_0 + \omega$ (15.91 GHz) does not appear in Figure 7(b) is due to the band limit of the spectrum analyzer (4 to 12.4 GHz).

If the light modulation is not a simple sinusoid, but is of the form

$$I(1 + m_1 \sin \omega t + m_2 \sin 2\omega t),$$

then the signal at the amplifier output will be

$$A\beta E_0 (1 + m_1 \sin \omega t + m_2 \sin 2\omega t) \sin \omega_0 t,$$

which contains the following frequency components:

$$A\beta E_0 \sin \omega_0 t, \frac{m_1 A\beta E_0}{2} \sin (\omega_0 \pm \omega)t, \text{ and } \frac{m_2 A\beta E_0}{2} \sin (\omega_0 \pm 2\omega)t .$$

Thus a nonsinusoidal light modulation generates higher order mixing terms. Higher order mixing can also occur if the amplifier gain does not vary linearly with the light intensity. In our experiment, the modulation of the laser output was typically less than 20%, and the amplifier gain was found to be linearly proportional to the small variations in the light intensity. Therefore, the higher order mixing term was generated by the nonsinusoidal light modulation.

In summary, the basic principle of this mixing approach is different from that of the conventional mixer diodes where the nonlinear admittance of the device is responsible for the mixing. In our scheme, the modulation of the amplifier gain is the key. More work is necessary to further characterize this new mixer, especially in the area of determining its noise figure and its conversion efficiency.

SECTION 4

INJECTION LOCKING OF A 440-MHz OSCILLATOR

BY OPTICAL ILLUMINATION OF AN AMPLIFIER

A somewhat different approach to achieving optical injection locking of transistor oscillators was experimented with during this quarter. A schematic of the experimental arrangement is shown in Figure 9(a). A transistor oscillator at 440 MHz was connected to a single-stage GaAs FET amplifier with a gain of about 14 dB at this frequency. A sweep oscillator was used to modulate a GaAlAs laser. The output of the laser was focused onto the GaAs chip in the amplifier. With this arrangement, we were able to achieve phase locking of the 440 MHz transistor oscillator with a locking range of about 600 kHz (0.15% of 440 MHz).

For comparison, the original optical injection locking scheme is depicted in Figure 9(b), where the modulated laser light is focused onto the oscillator directly. Using an amplifier might yield the following advantages:

- Less frequency shift caused by optical illumination. In the original arrangement, the laser beam is focused onto the transistor in the oscillator circuit, which changes the transistor characteristics and thus the oscillation frequency. In the new arrangement, the amplifier acts as part of the load of the oscillator, hence its variation due to optical illumination should have a smaller effect on the oscillation frequency shift.
- If the active element in the oscillator circuit is packaged so that it is not easily accessible for illumination or if the active element is not very light sensitive, the new arrangement will be particularly attractive.
- For IMPATT diode oscillators, it is difficult to achieve uniform optical illumination because of the specific structure of the device. This may generate additional noise in the oscillator output. If a high-frequency FET amplifier is available, we might be able to solve this problem.

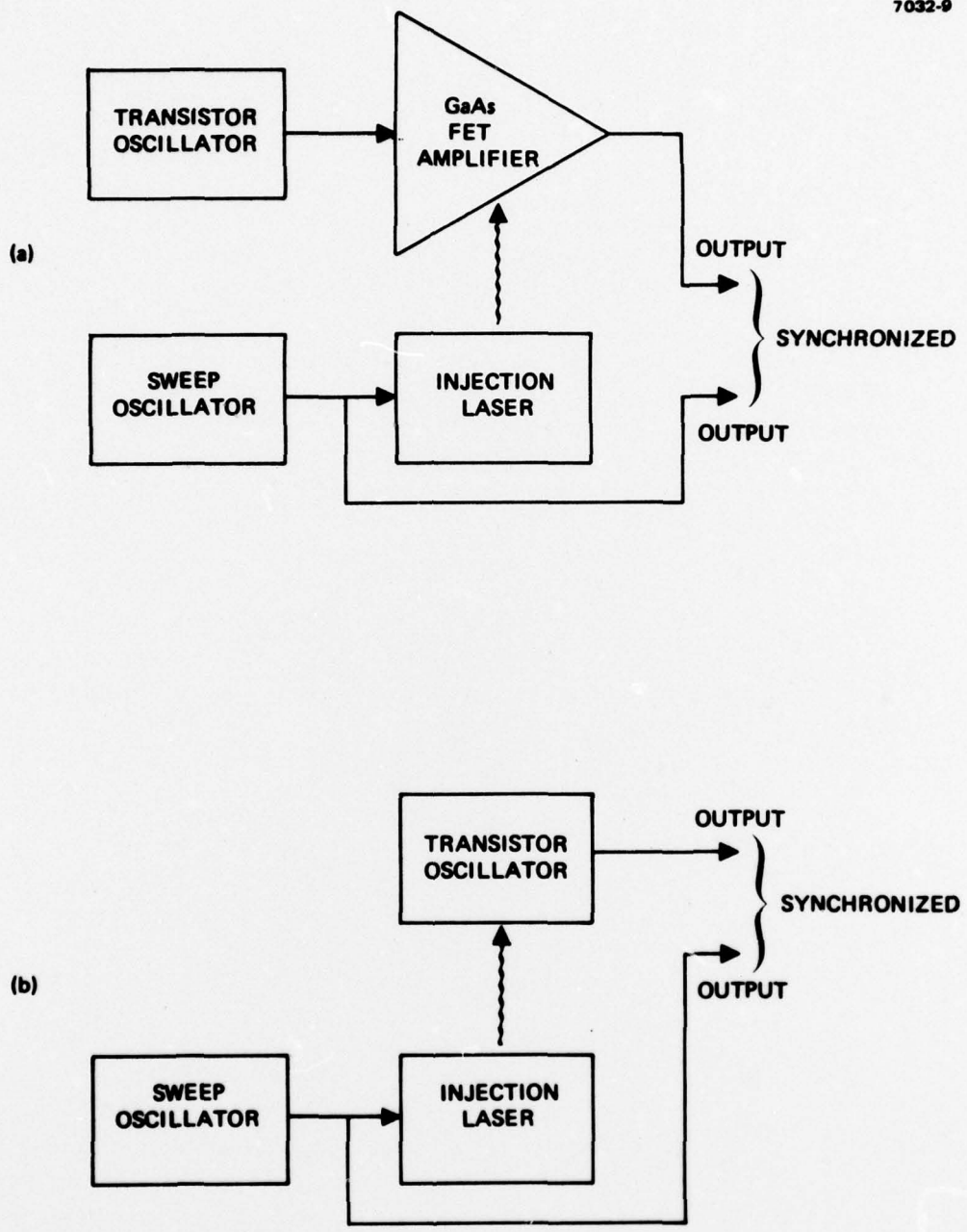

Figure 9. Schematics of two optical injection locking schemes.

- Because of the amplifier gain, the total locking gain of the system is enhanced.

A possible drawback is that the locking range might be reduced because it is more difficult to pull the oscillator frequency. Further study is needed to verify these points.

SECTION 5

DIRECT MODULATION OF INJECTION LASERS

As described in the last quarterly report,³ we are studying the modulation characteristics of a single-mode channeled-substrate-planar-structure (CSP) injection laser. Our previous attempt to determine the maximum modulation frequency of the laser failed because of the bandwidth limitation of our detector. Recently, a GaAs avalanche photodiode (APD) was acquired from Rockwell International Science Center that had a theoretical bandwidth of greater than 10 GHz. To protect the APD from excessive current, a limiting circuit was constructed to limit the total dc current through the APD to less than 200 μ A. This in turn limited the gain of the detector to about 10. Nevertheless, the detector proved to be sensitive enough for detecting the modulated laser output. Figure 10 shows two oscilloscope traces of the laser output modulated at 3.8 and 4.0 GHz, respectively. The optical modulation depth at these frequencies was typically 15%.

To determine the maximum modulation frequency of this laser, a spectrum analyzer was used to display the APD output signal. It was found that the laser could be modulated up to slightly more than 6 GHz. We believe that this was not limited by the detection system.

Because it is a single-mode laser, the output optical power versus injected current of the CSP laser is extremely linear. This characteristic is very important for analog system applications. In our last report, we showed that, for a sinusoidal input modulation signal at 1 GHz, the measured second harmonic content in the optical output was 24 dB down from the desired signal. In that experiment, although the voltage signal applied to the circuit was sinusoidal, the actual laser current might not vary sinusoidally. Therefore, we constructed the circuit shown in Figure 11(a). A GaAs FET was used to convert the voltage source from the signal generator into a current source, and the rest of the circuit was to provide the laser diode a dc bias

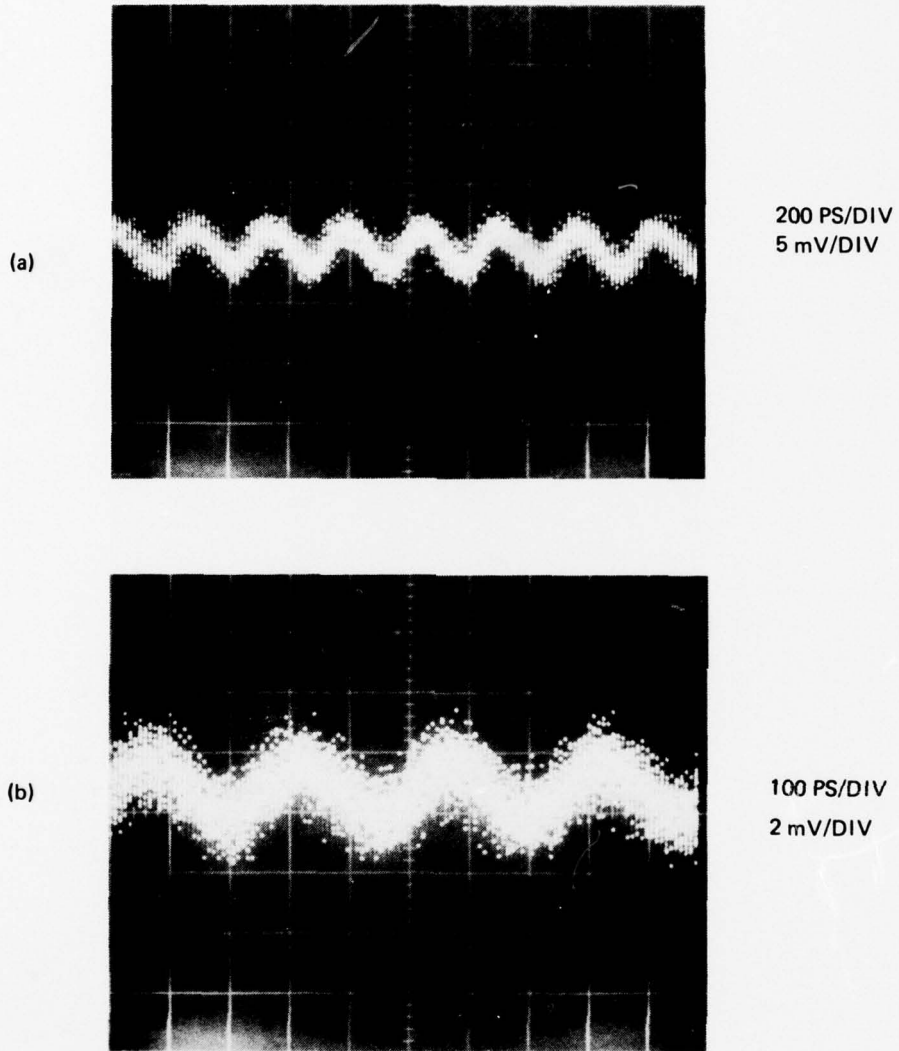

Figure 10. Oscilloscope traces of modulated injection laser output at (a) 3.8 GHz and (b) 4.0 GHz.

current variable around the threshold. The total dc current of the power supply was monitored. It was found that a total current of 75 mA corresponded roughly to the laser threshold. The linearity of the laser output power versus its driving current was determined by the amount of second harmonic component (2 GHz) as compared to the desired signal (1 GHz). The signal generator output was fixed to a certain output power level such that its second harmonic distortion was at least -54 dB. The total current was varied from ~ 75 mA to ~ 120 mA. We found that the second harmonic distortion was as low as -40 dB, which was achieved at high drive current, and is possibly limited by the silicon avalanche photodiode used for detection. As the driving current was decreased (in effect, as the modulation depth was increased), the distortion level rose rapidly, as shown in Figure 11(b).

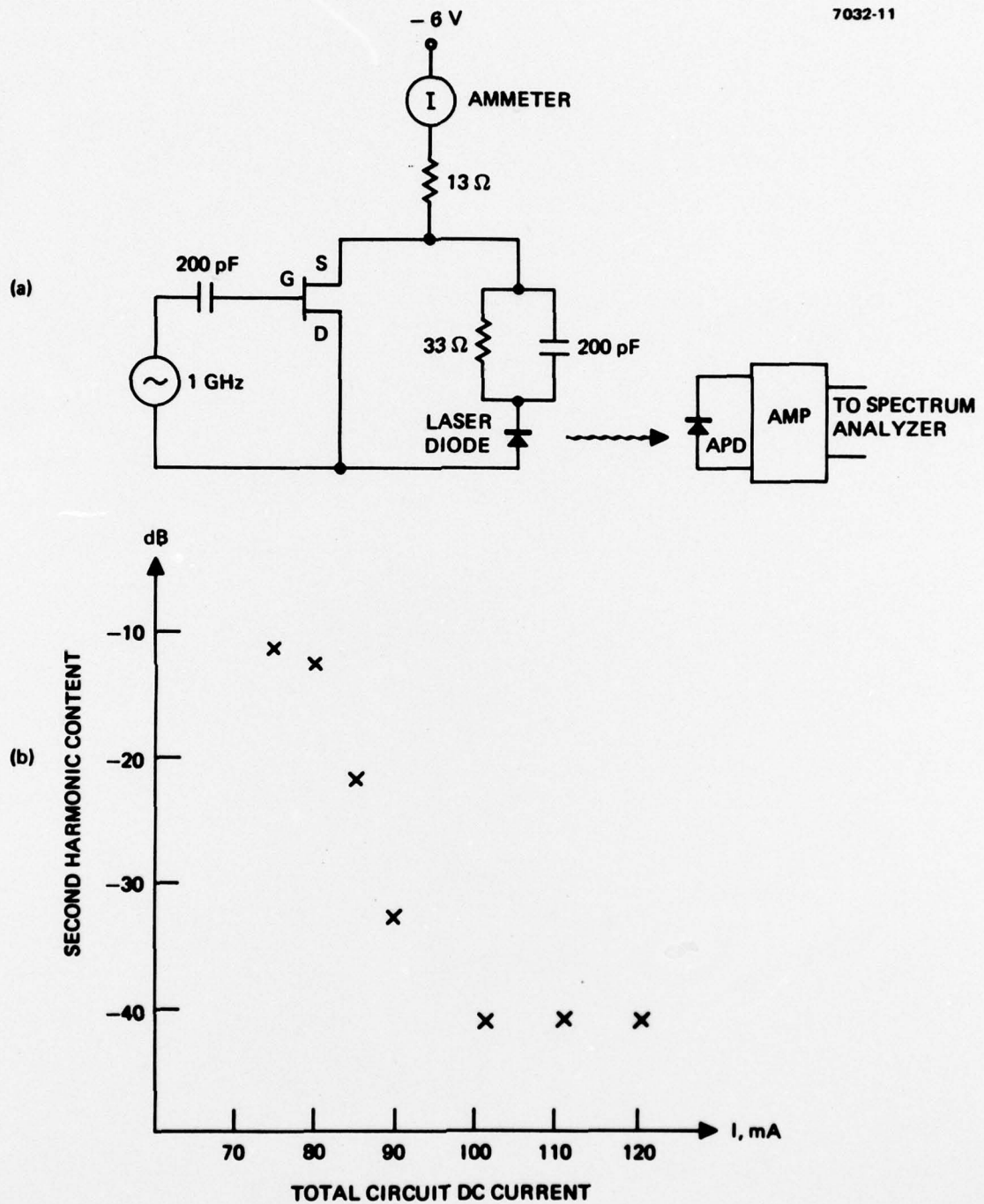

Figure 11. Linearity measurement of laser output power versus driving current characteristics. (a) experimental circuit diagram, (b) second harmonic content versus total circuit dc current.

SECTION 6

PLANS FOR THE NEXT QUARTER

In the next quarter, we will concentrate more on the theoretical aspects of the program. The interaction physics of the various optical-microwave processes will be studied in greater detail. Specifically, we will study the optical response of GaAs FET and IMPATT diodes to determine the optimum method of signal coupling; investigate the reasons why optical illumination can reduce the frequency jitter in a solid-state oscillator; and investigate methods of improving the GaAs FET amplifier as a microwave mixer. We will continue the evaluation of the new optical injection-locking technique. We will also continue the characterization of the GaAs FET mixer to determine its noise figure and conversion efficiency. An experiment with optical injection locking, involving IMPATT diode oscillators and GaAs transferred electron devices, will be carried out, and millimeter-wave modulation of semiconductor lasers will also be attempted.

SECTION 7

SUMMARY

During this quarter, we designed and fabricated a microwave GaAs FET oscillator, achieved injection locking of this oscillator, and reduced frequency jitter by using optical illumination. We also demonstrated a novel scheme of microwave mixing in a GaAs FET amplifier, where the local oscillator signal was introduced through optical injection.

A different approach to obtaining optical injection locking was also described in which a FET amplifier was connected to the oscillator to be locked and the modulated laser beam was used to illuminate the amplifier instead of the oscillator directly. The merits of this new approach over the previous technique were also discussed.

Direct modulation speed of a single-mode injection laser was determined to be at least 6 GHz, and the linearity of its input-output characteristics was found to be better than -40 dB in second harmonic distortion.

REFERENCES

1. H. W. Yen, M. K. Barnoski, R. G. Hunsperger, and R. T. Melville, Appl. Phys. Lett. 31, 120 (1977).
2. R. A. Kiehl and E. P. Eer Nisse, 1976 IEDM Technical Digest, p. 98.
3. H. W. Yen and M. K. Barnoski, "Optical-microwave interactions in semiconductor devices," Quarterly Report 1, Contract N00173-77-C-0156, October 1977.
4. "S-Parameters: Circuit analysis and design," HP application note 95.
5. M. Maeda, K. Kimura, and H. Kodaera, IEEE Trans. Microwave Theory Tech. MTT 23, 661 (1975).